

ARMY *TM 9-2320-272-23-1

AIR FORCE *TO 36A12-1C-1155-2-1

TECHNICAL MANUAL FIELD MAINTENANCE MANUAL FOR

TRUCK, 5-TON, 6X6, M939, M939A1, AND M939A2 SERIES TRUCKS (DIESEL)

TRUCK, CARGO: 5-TON, 6X6 DROPSIDE M923 NSN 2320-01-050-2084 (EIC BRY) M923A1 NSN 2320-01-206-4087 (EIC BSS) M923A2 NSN 2320-01-230-0307 (EIC BS7) M925 NSN 2320-01-047-8769 (EIC BRT) M925A1 NSN 2320-01-206-4088 (EIC BST) M925A2 NSN 2320-01-230-0308 (EIC BS8)	TRUCK, DUMP: 5-TON, 6X6 M929 NSN 2320-01-047-8756 (EIC BTH) M929A1 NSN 2320-01-206-4079 (EIC BSY) M929A2 NSN 2320-01-230-0305 (EIC BTN) M930 NSN 2320-01-047-8755 (EIC BTG) M930A1 NSN 2320-01-206-4080 (EIC BSZ) M930A2 NSN 2320-01-230-0306 (EIC BT7)	TRUCK, VAN, EXPANSIBLE: 5-TON, 6X6 M934 NSN 2320-01-047-8750 (EIC BTB) M934A1 NSN 2320-01-205-2682 (EIC BS4) M934A2 NSN 2320-01-230-0300 (EIC BTR)
TRUCK, CARGO: 5-TON, 6X6 XLWB M927 NSN 2320-01-047-8771 (EIC BRV) M927A1 NSN 2320-01-206-4089 (EIC BSW) M927A2 NSN 2320-01-230-0309 (EIC BS9) M928 NSN 2320-01-047-8770 (EIC BRU) M928A1 NSN 2320-01-206-4090 (EIC BSX) M928A2 NSN 2320-01-230-0310 (EIC BTM)	TRUCK, TRACTOR: 5-TON, 6X6 M931 NSN 2320-01-047-8753 (EIC BTE) M931A1 NSN 2320-01-206-4077 (EIC BS2) M931A2 NSN 2320-01-230-0302 (EIC BTP) M932 NSN 2320-01-047-8752 (EIC BTD) M932A1 NSN 2320-01-205-2684 (EIC BSZ) M932A2 NSN 2320-01-230-0303 (EIC BTQ)	TRUCK, MEDIUM WRECKER: 5-TON, 6X6 M936 NSN 2320-01-047-8754 (EIC BTF) M936A1 NSN 2320-01-206-4078 (EIC BS6) M936A2 NSN 2320-01-230-0304 (EIC BTT)

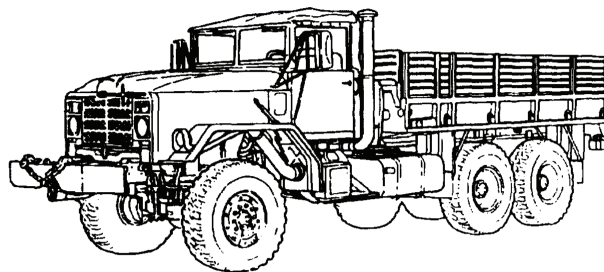

***SUPERSEDURE NOTICE** - This manual supersedes TM 9-2320-272-24-1, TM 9-2320-272-24-2, TM 9-2320-272-24-3, TM 9-2320-272-24-4 and TO 36A12-1C-1155-2-1, TO 36A12-1C-1155-2-2, TO 36A12-1C-1155-2-3, & TO 36A12-1C-1155-2-4, dated 30 June 1998, including all changes.

DISTRIBUTION STATEMENT A - Approved for public release; distribution is unlimited.

HEADQUARTERS, DEPARTMENTS OF THE ARMY AND THE AIR FORCE
10 SEPTEMBER 2012

WARNING SUMMARY

This warning summary contains general safety warnings and hazardous materials warnings that must be understood and applied during operation and maintenance of the vehicle. Failure to observe these precautions or operating this vehicle without training or instruction may result in serious injury or death to personnel.

FIRST AID DATA

For information on first aid, refer to FM 4-25.11, First Aid.

EXPLANATION OF SAFETY WARNING ICONS



EAR PROTECTION - Headphones over ears show that noise level will harm ears.



ELECTRICAL - Electrical wire to hand with electricity symbol running through hand shows that shock hazard is present.

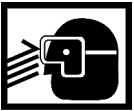

EYE PROTECTION - Person with goggles shows that the material will injure the eyes.



FIRE - Flame shows that a material may ignite and cause burns.



HEAVY OBJECT - Human figure stooping over heavy object shows physical injury potential from improper lifting technique.



HEAVY PARTS - Hand with heavy object on top shows that heavy parts can crush and harm.



HEAVY PARTS - Foot with heavy object on top shows that heavy parts can crush and harm.



HEAVY PARTS - Heavy object pinning human figure against wall shows that heavy, moving parts present a danger to life or limb.

WARNING SUMMARY - Continued

EXPLANATION OF SAFETY WARNING ICONS - Continued



HEAVY PARTS - Heavy object on human figure shows that heavy parts present a danger to life or limb.



HOT AREA - Hand over object radiating heat shows that part is hot and can burn.



MOVING PARTS - Hand with fingers caught between gears shows that the moving parts of the equipment present a danger to life or limb.



RADIATION - Three circular wedges shows that the material emits radioactive energy and can injure human tissue.



SLICK FLOOR - Wavy line on floor with legs prone shows that slick floor presents a danger for falling.



VAPOR - Human figure in a cloud shows that material vapors present a danger to life or health.

WARNING SUMMARY - Continued

GENERAL SAFETY WARNINGS DESCRIPTION

WARNING



Ensure electrical power is off prior to working on all electrical connections. Prior to working on or around vehicle, remove all jewelry, such as rings, ID tags, bracelets, etc. Jewelry, and tools can catch on equipment, contact positive electrical circuits, and cause a direct short, severe burns, or electrical shock. Failure to comply may result in injury or death to personnel.

WARNING



Personnel hearing can be permanently damaged if exposed to constant high noise levels of 85 dB or greater. Failure to comply may result in injury to personnel.

WARNING

Unless otherwise specified, perform all maintenance procedures with all attachments lowered to the ground, pilot shutoff lever in the up position, and engine shut off. Failure to comply may result in injury or death to personnel.

WARNING SUMMARY - Continued

EXPLANATION OF HAZARDOUS MATERIALS ICONS



BIOLOGICAL - Abstract symbol bug shows that a material may contain bacteria or viruses that present a danger to life or health.



CHEMICAL - Drops of liquid on hand shows that the material will cause burns or irritation to human skin or tissue.



EXPLOSION - Rapidly expanding symbol shows that the material may explode if subjected to high temperatures, sources of ignition, or high pressure.



POISON - Skull and crossbones symbol shows that dangerous gases, sprays, vapors, liquids, or materials contain compounds that present a danger to life or health.

WARNING SUMMARY - Continued

HAZARDOUS MATERIALS DESCRIPTIONS

WARNING



CARBON MONOXIDE

- Carbon monoxide is a colorless, odorless, deadly poison which, when breathed, deprives the body of oxygen and causes suffocation. Exposure to air containing carbon monoxide produces symptoms of headache, dizziness, loss of muscular control, apparent drowsiness, and coma. Permanent brain damage or death to personnel can result from severe exposure.
- Carbon monoxide occurs in exhaust fumes from internal combustion engines. It also occurs in exhaust fumes from engine coolant heater (arctic machine only). Carbon monoxide can become dangerously concentrated under conditions of inadequate ventilation. The following precautions must be observed to ensure safety of personnel when engine of vehicle is operated.
 1. DO NOT operate engine in enclosed area without adequate ventilation.
 2. DO NOT idle engine without adequate ventilation.
 3. DO NOT drive machine with inspection plates or cover plates removed.
 4. BE ALERT for exhaust poisoning symptoms. They are:
 - Headache
 - Dizziness
 - Sleepiness
 - Loss of muscular control
 5. If you see another person with exhaust poisoning symptoms:
 - Remove person from area
 - Expose to fresh air
 - Keep person warm
 - DO NOT permit physical exercise
 - Administer cardiopulmonary resuscitation (CPR) if necessary
 - Notify a Medic
 6. BE AWARE. The field protective mask for Nuclear-Biological-Chemical (NBC) protection will not protect you from carbon monoxide poisoning.

WARNING SUMMARY - Continued

HAZARDOUS MATERIALS DESCRIPTIONS - Continued

WARNING



CHEMICAL AGENT RESISTANT COATING (CARC) PAINT

Chemical Agent Resistant Coating (CARC) paint contains isocyanate which is highly irritating to skin and respiratory system. High concentrations of isocyanate can produce symptoms of itching and reddening of skin, a burning sensation in the throat and nose, and watering of the eyes. In extreme concentrations, isocyanate can cause cough, shortness of breath, pain during respiration, increased sputum production, and chest tightness. First aid for ingestion: do not induce vomiting. Seek immediate medical attention. First aid for skin contact: remove contaminated clothing. Wash skin thoroughly with soap and water. If symptoms persist, seek medical attention. First aid for inhalation: move to fresh air. If not breathing, provide artificial respiration. If symptoms persist, seek medical attention. Failure to comply may result in injury or death to personnel.

WARNING SUMMARY - Continued**HAZARDOUS MATERIALS DESCRIPTIONS - Continued****WARNING****SOLVENT CLEANING COMPOUND**

Solvent cleaning compound MIL-PRF-680 type II and III may be irritating to the eyes and skin. Use protective gloves and goggles. Use in well ventilated areas. Use respirator as needed.

Accidental ingestion can cause irritation of digestive tract and repository tract, and may cause lung and central nervous system damage. Can be fatal if swallowed. First aid for ingestion: do not induce vomiting. Seek immediate medical attention.

First aid for skin contact: remove contaminated clothing, Wash skin thoroughly with soap and water. If symptoms persist, seek medical attention.

First aid for eye contact: flush with water for 15 minutes or until irritation subsides. If symptoms persist, seek medical attention.

Inhalation of high/massive concentrations can cause coma or be fatal. First aid for inhalation: move to fresh air. If not breathing, provide artificial respiration. If symptoms persist, seek medical attention.

Keep away from open flames and other sources of ignition. Failure to comply may result in injury or death to personnel. The flash point for type II solvent cleaning compound is 141°F to 198°F (61°C to 92°C) and type III is 200°F to 241°F (93°C to 116°C). Fire extinguishers should be placed nearby when using solvent cleaning compound.

Improper cleaning methods and use of unauthorized cleaning solvents may injure personnel and damage equipment.

Cloths or rags saturated with solvent cleaning compound must be disposed of using authorized facilities procedures.

Eye shields must be worn when cleaning with a wire brush. Flying rust and metal particles may cause injury.

WARNING SUMMARY - Continued

HAZARDOUS MATERIALS DESCRIPTIONS - Continued

WARNING



LUBRICATING OIL

Prolonged contact with lubricating oil may cause skin rash. Remove saturated clothing immediately and wash skin thoroughly that comes in contact with lubricating oil. Failure to comply may result in injury or death to personnel.

Spilled hydraulic oil is slippery and creates a hazardous condition. Clean up and properly dispose of hydraulic oil. Failure to comply may result in injury or death to personnel.

WARNING



NUCLEAR, BIOLOGICAL, OR CHEMICAL

If Nuclear, Biological, or Chemical (NBC) exposure is suspected, all filter media should be handled by personnel wearing protective equipment. Consult your unit NBC Officer or NBC NCO for appropriate handling or disposal instructions. Failure to comply may result in injury or death to personnel.

WARNING SUMMARY - Continued

HAZARDOUS MATERIALS DESCRIPTIONS - Continued

WARNING



LEAD-ACID BATTERIES

Avoid battery electrolyte contact with skin, eyes, and clothing. If battery electrolyte spills, take the following immediate action to stop burning effects:

External - If battery electrolyte contacts skin, immediately flush affected area with cold running water. Failure to comply may result in injury or death to personnel.

Eyes - If battery electrolyte contacts eyes, immediately flush eyes with cold water for 15 minutes and seek immediate medical attention. **IMPORTANT** - If only one eye is affected, ensure the affected eye is always kept lower than the unaffected eye, during both flushing and transport. This will keep the the affected eye from draining into and contaminating the unaffected eye. Failure to comply may result in injury or death to personnel.

Internal - If battery electrolyte is ingested, drink large amounts of water or milk. Follow with milk of magnesia, a beaten egg or vegetable oil and seek immediate medical attention. Failure to comply may result in injury or death to personnel.

Clothing or vehicle - immediately flush area with cold water and neutralize battery electrolyte with baking soda or household ammonia solution. Failure to comply may result in injury or death to personnel.

Batteries produce explosive gases. Do not smoke or use open flame near batteries. Do not allow hot, parking or glowing objects near batteries. If batteries are giving off gases, the presence of heat, flame, or spark may cause fire and/or explosion. Failure to comply may result in injury or death to personnel.

Wear proper eye protection, gloves, and an apron when working near batteries. Failure to comply may result in injury or death to personnel.

WARNING SUMMARY - Continued

HAZARDOUS MATERIALS DESCRIPTIONS - Continued

WARNING



DIESEL FUEL

- Diesel fuel is highly flammable and can be accidentally ignited. Do not smoke or allow open flame or sparks in the vicinity while working on any part of the fuel system. Keep fire extinguisher within easy reach when working with fuel. Failure to comply may result in injury or death to personnel.
- Spilled fuel is slippery and creates a hazardous condition. Clean up and properly disposed of spilled fuel as soon as possible. Failure to comply may result in injury or death to personnel.
- Do not work on fuel system when engine is hot. Failure to comply may result in injury or death to personnel.
- Safety glasses must be worn when working on pressurized systems. Failure to comply may result in injury or death to personnel.

WARNING



ADHESIVES AND SEALANTS

Adhesives and sealants are flammable, can give off harmful vapors, and are harmful to skin and clothing. Keep away from open fire and use in a well-ventilated area. If adhesive or sealant contacts eye, flush with large amounts of water, and seek medical attention. If adhesive or sealant get on skin or clothing, flush with large amounts of water. If irritation persists, seek medical attention. Failure to comply may result in serious injury or death to personnel.

LIST OF EFFECTIVE PAGES/WORK PACKAGES

NOTE: *Supersedes TM 9-2320-272-24-1, TM 9-2320-272-24-2, TM 9-2320-272-24-3, TM 9-2320-272-24-4 and TO 36A12-1C-1155-2-1, TO 36A12-1C-1155-2-2, TO 36A12-1C-1155-2-3, & TO 36A12-1C-1155-2-4, dated 30 June 1998. Zero in the Change No. Column indicates an original page or work package.

Date of issue for the original manual is:

Original 10 September 2012

TOTAL NUMBER OF VOLUMES IS 5, TOTAL NUMBER OF PAGES FOR FRONT AND REAR MATTER IS 510 AND TOTAL NUMBER OF WORK PACKAGES IS 828 CONSISTING OF THE FOLLOWING:

Page/WP No.	Change No.	Page/WP No.	Change No.
VOLUME 1		WP 0035 (4 pages)	0
Front Cover (2 pages)	0	WP 0036 (4 pages)	0
WARNING SUMMARY (10 pages)	0	WP 0037 (2 pages)	0
i-clii (152 pages)	0	WP 0038 (4 pages)	0
Chapter 1 Title Page (2 pages)	0	WP 0039 (6 pages)	0
WP 0001 (6 pages)	0	WP 0040 (8 pages)	0
WP 0002 (24 pages)	0	WP 0041 (4 pages)	0
WP 0003 (60 pages)	0	WP 0042 (4 pages)	0
Chapter 2 Title Page (2 pages)	0	WP 0043 (6 pages)	0
WP 0004 (2 pages)	0	WP 0044 (6 pages)	0
WP 0005 (8 pages)	0	WP 0045 (6 pages)	0
WP 0006 (8 pages)	0	WP 0046 (4 pages)	0
WP 0007 (22 pages)	0	WP 0047 (4 pages)	0
WP 0008 (4 pages)	0	WP 0048 (6 pages)	0
WP 0009 (10 pages)	0	WP 0049 (4 pages)	0
WP 0010 (4 pages)	0	WP 0050 (6 pages)	0
WP 0011 (4 pages)	0	WP 0051 (4 pages)	0
WP 0012 (8 pages)	0	WP 0052 (6 pages)	0
WP 0013 (4 pages)	0	WP 0053 (12 pages)	0
WP 0014 (16 pages)	0	WP 0054 (8 pages)	0
WP 0015 (6 pages)	0	WP 0055 (6 pages)	0
WP 0016 (4 pages)	0	WP 0056 (4 pages)	0
WP 0017 (6 pages)	0	WP 0057 (4 pages)	0
WP 0018 (6 pages)	0	WP 0058 (6 pages)	0
WP 0019 (2 pages)	0	WP 0059 (14 pages)	0
WP 0020 (4 pages)	0	WP 0060 (6 pages)	0
WP 0021 (16 pages)	0	WP 0061 (4 pages)	0
WP 0022 (2 pages)	0	WP 0062 (4 pages)	0
WP 0023 (4 pages)	0	WP 0063 (4 pages)	0
WP 0024 (6 pages)	0	WP 0064 (6 pages)	0
WP 0025 (6 pages)	0	WP 0065 (4 pages)	0
WP 0026 (6 pages)	0	WP 0066 (4 pages)	0
WP 0027 (6 pages)	0	WP 0067 (6 pages)	0
WP 0028 (16 pages)	0	WP 0068 (6 pages)	0
WP 0029 (8 pages)	0	WP 0069 (2 pages)	0
WP 0030 (4 pages)	0	WP 0070 (4 pages)	0
WP 0031 (6 pages)	0	WP 0071 (2 pages)	0
WP 0032 (4 pages)	0	WP 0072 (6 pages)	0
WP 0033 (4 pages)	0	WP 0073 (2 pages)	0
WP 0034 (4 pages)	0	WP 0074 (6 pages)	0

LIST OF EFFECTIVE PAGES/WORK PACKAGES - Continued

Page/WP No.	Change No.	Page/WP No.	Change No.
WP 0075 (4 pages)	0	WP 0126 (12 pages)	0
WP 0076 (4 pages)	0	WP 0127 (4 pages)	0
WP 0077 (2 pages)	0	WP 0128 (4 pages)	0
WP 0078 (4 pages)	0	WP 0129 (6 pages)	0
WP 0079 (4 pages)	0	WP 0130 (8 pages)	0
WP 0080 (4 pages)	0	WP 0131 (10 pages)	0
WP 0081 (6 pages)	0	WP 0132 (4 pages)	0
WP 0082 (4 pages)	0	WP 0133 (8 pages)	0
WP 0083 (4 pages)	0	WP 0134 (2 pages)	0
WP 0084 (8 pages)	0	WP 0135 (8 pages)	0
WP 0085 (8 pages)	0	WP 0136 (6 pages)	0
WP 0086 (4 pages)	0	WP 0137 (4 pages)	0
WP 0087 (10 pages)	0	WP 0138 (4 pages)	0
WP 0088 (16 pages)	0	WP 0139 (4 pages)	0
WP 0089 (10 pages)	0	WP 0140 (12 pages)	0
WP 0090 (14 pages)	0	WP 0141 (4 pages)	0
WP 0091 (8 pages)	0	Chapter 3 Title Page (2 pages)	0
WP 0092 (4 pages)	0	WP 0142 (2 pages)	0
WP 0093 (6 pages)	0	WP 0143 (2 pages)	0
WP 0094 (8 pages)	0	WP 0144 (24 pages)	0
WP 0095 (12 pages)	0	WP 0145 (12 pages)	0
WP 0096 (8 pages)	0	WP 0146 (20 pages)	0
WP 0097 (6 pages)	0	WP 0147 (6 pages)	0
WP 0098 (8 pages)	0	WP 0148 (14 pages)	0
WP 0099 (6 pages)	0	WP 0149 (12 pages)	0
WP 0100 (12 pages)	0	WP 0150 (6 pages)	0
WP 0101 (4 pages)	0	WP 0151 (4 pages)	0
WP 0102 (4 pages)	0	WP 0152 (10 pages)	0
WP 0103 (8 pages)	0	WP 0153 (10 pages)	0
WP 0104 (6 pages)	0	Index 1 - Index 5/6 blank (6 pages)	0
WP 0105 (6 pages)	0	Inside Back Cover	0
WP 0106 (6 pages)	0	Back Cover	0
WP 0107 (8 pages)	0		
WP 0108 (4 pages)	0	VOLUME 2	
WP 0109 (10 pages)	0	Front Cover (2 pages)	0
WP 0110 (12 pages)	0	WARNING SUMMARY (10 pages)	0
WP 0111 (4 pages)	0	i-xxxvii/xxxviii blank (38 pages)	0
WP 0112 (6 pages)	0	Chapter 4 Title Page (2 pages)	0
WP 0113 (8 pages)	0	WP 0154 (6 pages)	0
WP 0114 (6 pages)	0	WP 0155 (2 pages)	0
WP 0115 (6 pages)	0	WP 0156 (16 pages)	0
WP 0116 (6 pages)	0	WP 0157 (4 pages)	0
WP 0117 (4 pages)	0	WP 0158 (4 pages)	0
WP 0118 (6 pages)	0	WP 0159 (6 pages)	0
WP 0119 (6 pages)	0	WP 0160 (8 pages)	0
WP 0120 (56 pages)	0	WP 0161 (8 pages)	0
WP 0121 (8 pages)	0	WP 0162 (8 pages)	0
WP 0122 (8 pages)	0	WP 0163 (8 pages)	0
WP 0123 (4 pages)	0	WP 0164 (4 pages)	0
WP 0124 (4 pages)	0	WP 0165 (4 pages)	0
WP 0125 (2 pages)	0	WP 0166 (6 pages)	0

LIST OF EFFECTIVE PAGES/WORK PACKAGES - Continued

Page/WP No.	Change No.	Page/WP No.	Change No.
WP 0167 (6 pages)	0	WP 0215 (2 pages)	0
WP 0168 (4 pages)	0	WP 0216 (10 pages)	0
WP 0169 (6 pages)	0	WP 0217 (4 pages)	0
WP 0170 (6 pages)	0	WP 0218 (6 pages)	0
WP 0171 (6 pages)	0	WP 0219 (6 pages)	0
WP 0172 (6 pages)	0	WP 0220 (4 pages)	0
WP 0173 (6 pages)	0	WP 0221 (6 pages)	0
WP 0174 (4 pages)	0	WP 0222 (16 pages)	0
WP 0175 (6 pages)	0	WP 0223 (10 pages)	0
WP 0176 (6 pages)	0	WP 0224 (4 pages)	0
WP 0177 (6 pages)	0	WP 0225 (4 pages)	0
WP 0178 (6 pages)	0	WP 0226 (6 pages)	0
WP 0179 (6 pages)	0	WP 0227 (4 pages)	0
WP 0180 (6 pages)	0	WP 0228 (6 pages)	0
WP 0181 (6 pages)	0	WP 0229 (10 pages)	0
WP 0182 (4 pages)	0	WP 0230 (6 pages)	0
WP 0183 (2 pages)	0	WP 0231 (10 pages)	0
WP 0184 (4 pages)	0	WP 0232 (10 pages)	0
WP 0185 (6 pages)	0	WP 0233 (8 pages)	0
Chapter 5 Title Page (2 pages)	0	WP 0234 (10 pages)	0
WP 0186 (4 pages)	0	WP 0235 (6 pages)	0
WP 0187 (2 pages)	0	WP 0236 (2 pages)	0
WP 0188 (10 pages)	0	WP 0237 (14 pages)	0
WP 0189 (4 pages)	0	WP 0238 (6 pages)	0
WP 0190 (4 pages)	0	WP 0239 (4 pages)	0
WP 0191 (4 pages)	0	WP 0240 (12 pages)	0
WP 0192 (2 pages)	0	WP 0241 (6 pages)	0
WP 0193 (4 pages)	0	WP 0242 (18 pages)	0
WP 0194 (2 pages)	0	WP 0243 (6 pages)	0
WP 0195 (4 pages)	0	WP 0244 (4 pages)	0
WP 0196 (4 pages)	0	WP 0245 (8 pages)	0
WP 0197 (4 pages)	0	WP 0246 (6 pages)	0
WP 0198 (2 pages)	0	WP 0247 (6 pages)	0
WP 0199 (4 pages)	0	WP 0248 (6 pages)	0
WP 0200 (4 pages)	0	WP 0249 (10 pages)	0
WP 0201 (2 pages)	0	WP 0250 (8 pages)	0
WP 0202 (10 pages)	0	WP 0251 (12 pages)	0
WP 0203 (8 pages)	0	WP 0252 (6 pages)	0
WP 0204 (6 pages)	0	WP 0253 (8 pages)	0
WP 0205 (2 pages)	0	WP 0254 (12 pages)	0
Chapter 6 Title Page (2 pages)	0	WP 0255 (6 pages)	0
WP 0206 (2 pages)	0	WP 0256 (10 pages)	0
WP 0207 (44 pages)	0	WP 0257 (4 pages)	0
WP 0208 (12 pages)	0	WP 0258 (12 pages)	0
WP 0209 (2 pages)	0	WP 0259 (6 pages)	0
Chapter 7 Title Page (2 pages)	0	WP 0260 (6 pages)	0
WP 0210 (2 pages)	0	WP 0261 (4 pages)	0
WP 0211 (56 pages)	0	WP 0262 (4 pages)	0
WP 0212 (8 pages)	0	WP 0263 (6 pages)	0
WP 0213 (40 pages)	0	WP 0264 (4 pages)	0
WP 0214 (4 pages)	0	WP 0265 (4 pages)	0

LIST OF EFFECTIVE PAGES/WORK PACKAGES - Continued

Page/WP No.	Change No.	Page/WP No.	Change No.
WP 0266 (6 pages)	0	WP 0317 (2 pages)	0
WP 0267 (6 pages)	0	WP 0318 (2 pages)	0
WP 0268 (8 pages)	0	WP 0319 (4 pages)	0
WP 0269 (12 pages)	0	WP 0320 (8 pages)	0
WP 0270 (6 pages)	0	WP 0321 (2 pages)	0
WP 0271 (6 pages)	0	WP 0322 (6 pages)	0
WP 0272 (4 pages)	0	WP 0323 (4 pages)	0
WP 0273 (4 pages)	0	WP 0324 (4 pages)	0
WP 0274 (6 pages)	0	WP 0325 (8 pages)	0
WP 0275 (6 pages)	0	WP 0326 (6 pages)	0
WP 0276 (6 pages)	0	WP 0327 (24 pages)	0
WP 0277 (6 pages)	0	WP 0328 (4 pages)	0
WP 0278 (10 pages)	0	WP 0329 (8 pages)	0
WP 0279 (6 pages)	0	WP 0330 (6 pages)	0
WP 0280 (14 pages)	0	WP 0331 (6 pages)	0
WP 0281 (8 pages)	0	WP 0332 (6 pages)	0
WP 0282 (6 pages)	0	WP 0333 (4 pages)	0
WP 0283 (6 pages)	0	WP 0334 (4 pages)	0
WP 0284 (6 pages)	0	WP 0335 (2 pages)	0
WP 0285 (10 pages)	0	WP 0336 (4 pages)	0
WP 0286 (6 pages)	0	WP 0337 (4 pages)	0
WP 0287 (6 pages)	0	WP 0338 (4 pages)	0
WP 0288 (6 pages)	0	WP 0339 (2 pages)	0
WP 0289 (10 pages)	0	WP 0340 (4 pages)	0
WP 0290 (8 pages)	0	WP 0341 (2 pages)	0
WP 0291 (4 pages)	0	WP 0342 (10 pages)	0
WP 0292 (4 pages)	0	WP 0343 (6 pages)	0
WP 0293 (6 pages)	0	WP 0344 (6 pages)	0
WP 0294 (8 pages)	0	WP 0345 (6 pages)	0
WP 0295 (4 pages)	0	WP 0346 (6 pages)	0
WP 0296 (6 pages)	0	WP 0347 (4 pages)	0
WP 0297 (6 pages)	0	WP 0348 (4 pages)	0
WP 0298 (6 pages)	0	WP 0349 (6 pages)	0
WP 0299 (6 pages)	0	WP 0350 (6 pages)	0
WP 0300 (10 pages)	0	Index 1 - Index 5/6 blank (6 pages)	0
WP 0301 (12 pages)	0	Inside Back Cover	0
WP 0302 (6 pages)	0	Back Cover	0
WP 0303 (6 pages)	0		
WP 0304 (4 pages)	0	VOLUME 3	
WP 0305 (6 pages)	0	Front Cover (2 pages)	0
WP 0306 (4 pages)	0	WARNING SUMMARY (10 pages)	0
WP 0307 (10 pages)	0	i-xxxix/xl blank (40 pages)	0
WP 0308 (6 pages)	0	Chapter 8 Title Page (2 pages)	0
WP 0309 (6 pages)	0	WP 0351 (4 pages)	0
WP 0310 (14 pages)	0	WP 0352 (6 pages)	0
WP 0311 (6 pages)	0	WP 0353 (6 pages)	0
WP 0312 (6 pages)	0	WP 0354 (12 pages)	0
WP 0313 (6 pages)	0	WP 0355 (6 pages)	0
WP 0314 (6 pages)	0	WP 0356 (10 pages)	0
WP 0315 (6 pages)	0	WP 0357 (48 pages)	0
WP 0316 (2 pages)	0	WP 0358 (36 pages)	0

LIST OF EFFECTIVE PAGES/WORK PACKAGES - Continued

Page/WP No.	Change No.	Page/WP No.	Change No.
WP 0359 (30 pages)	0	WP 0410 (4 pages)	0
WP 0360 (4 pages)	0	WP 0411 (8 pages)	0
WP 0361 (4 pages)	0	WP 0412 (12 pages)	0
WP 0362 (16 pages)	0	WP 0413 (2 pages)	0
WP 0363 (6 pages)	0	WP 0414 (14 pages)	0
WP 0364 (4 pages)	0	WP 0415 (4 pages)	0
WP 0365 (8 pages)	0	WP 0416 (2 pages)	0
WP 0366 (2 pages)	0	WP 0417 (2 pages)	0
WP 0367 (10 pages)	0	WP 0418 (4 pages)	0
WP 0368 (4 pages)	0	WP 0419 (8 pages)	0
WP 0369 (6 pages)	0	WP 0420 (6 pages)	0
WP 0370 (6 pages)	0	WP 0421 (6 pages)	0
WP 0371 (10 pages)	0	WP 0422 (6 pages)	0
WP 0372 (10 pages)	0	WP 0423 (4 pages)	0
WP 0373 (14 pages)	0	WP 0424 (6 pages)	0
WP 0374 (20 pages)	0	WP 0425 (6 pages)	0
WP 0375 (6 pages)	0	WP 0426 (4 pages)	0
WP 0376 (4 pages)	0	WP 0427 (12 pages)	0
WP 0377 (10 pages)	0	WP 0428 (10 pages)	0
WP 0378 (6 pages)	0	WP 0429 (10 pages)	0
WP 0379 (6 pages)	0	WP 0430 (10 pages)	0
WP 0380 (4 pages)	0	WP 0431 (6 pages)	0
WP 0381 (6 pages)	0	WP 0432 (6 pages)	0
WP 0382 (14 pages)	0	WP 0433 (4 pages)	0
WP 0383 (6 pages)	0	WP 0434 (6 pages)	0
WP 0384 (4 pages)	0	WP 0435 (8 pages)	0
WP 0385 (18 pages)	0	WP 0436 (8 pages)	0
WP 0386 (24 pages)	0	WP 0437 (4 pages)	0
WP 0387 (6 pages)	0	WP 0438 (6 pages)	0
WP 0388 (4 pages)	0	WP 0439 (4 pages)	0
WP 0389 (6 pages)	0	WP 0440 (6 pages)	0
WP 0390 (6 pages)	0	WP 0441 (6 pages)	0
WP 0391 (6 pages)	0	WP 0442 (10 pages)	0
WP 0392 (6 pages)	0	WP 0443 (8 pages)	0
WP 0393 (6 pages)	0	WP 0444 (6 pages)	0
WP 0394 (6 pages)	0	WP 0445 (6 pages)	0
WP 0395 (4 pages)	0	WP 0446 (6 pages)	0
WP 0396 (14 pages)	0	WP 0447 (6 pages)	0
WP 0397 (4 pages)	0	WP 0448 (6 pages)	0
WP 0398 (6 pages)	0	WP 0449 (6 pages)	0
WP 0399 (4 pages)	0	WP 0450 (14 pages)	0
WP 0400 (4 pages)	0	WP 0451 (4 pages)	0
WP 0401 (14 pages)	0	WP 0452 (4 pages)	0
WP 0402 (6 pages)	0	WP 0453 (4 pages)	0
WP 0403 (8 pages)	0	WP 0454 (4 pages)	0
WP 0404 (10 pages)	0	WP 0455 (6 pages)	0
WP 0405 (2 pages)	0	WP 0456 (6 pages)	0
WP 0406 (6 pages)	0	WP 0457 (6 pages)	0
WP 0407 (4 pages)	0	WP 0458 (6 pages)	0
WP 0408 (4 pages)	0	WP 0459 (6 pages)	0
WP 0409 (4 pages)	0	WP 0460 (4 pages)	0

LIST OF EFFECTIVE PAGES/WORK PACKAGES - Continued

Page/WP No.	Change No.	Page/WP No.	Change No.
WP 0461 (6 pages)	0	WP 0512 (6 pages)	0
WP 0462 (6 pages)	0	WP 0513 (22 pages)	0
WP 0463 (4 pages)	0	WP 0514 (4 pages)	0
WP 0464 (4 pages)	0	WP 0515 (2 pages)	0
WP 0465 (4 pages)	0	WP 0516 (6 pages)	0
WP 0466 (4 pages)	0	WP 0517 (4 pages)	0
WP 0467 (10 pages)	0	WP 0518 (6 pages)	0
WP 0468 (6 pages)	0	WP 0519 (8 pages)	0
WP 0469 (4 pages)	0	WP 0520 (6 pages)	0
WP 0470 (8 pages)	0	WP 0521 (4 pages)	0
WP 0471 (6 pages)	0	WP 0522 (6 pages)	0
WP 0472 (4 pages)	0	WP 0523 (10 pages)	0
WP 0473 (4 pages)	0	WP 0524 (6 pages)	0
WP 0474 (6 pages)	0	WP 0525 (4 pages)	0
WP 0475 (6 pages)	0	WP 0526 (10 pages)	0
WP 0476 (6 pages)	0	WP 0527 (4 pages)	0
WP 0477 (6 pages)	0	WP 0528 (6 pages)	0
WP 0478 (6 pages)	0	WP 0529 (4 pages)	0
WP 0479 (6 pages)	0	WP 0530 (4 pages)	0
WP 0480 (8 pages)	0	WP 0531 (2 pages)	0
WP 0481 (10 pages)	0	WP 0532 (2 pages)	0
WP 0482 (12 pages)	0	WP 0533 (2 pages)	0
WP 0483 (6 pages)	0	WP 0534 (12 pages)	0
WP 0484 (8 pages)	0	WP 0535 (4 pages)	0
WP 0485 (6 pages)	0	WP 0536 (4 pages)	0
WP 0486 (6 pages)	0	WP 0537 (2 pages)	0
WP 0487 (6 pages)	0	WP 0538 (2 pages)	0
WP 0488 (6 pages)	0	WP 0539 (12 pages)	0
WP 0489 (6 pages)	0	WP 0540 (10 pages)	0
WP 0490 (6 pages)	0	WP 0541 (6 pages)	0
WP 0491 (6 pages)	0	WP 0542 (4 pages)	0
WP 0492 (4 pages)	0	WP 0543 (4 pages)	0
WP 0493 (6 pages)	0	WP 0544 (12 pages)	0
WP 0494 (10 pages)	0	WP 0545 (4 pages)	0
WP 0495 (4 pages)	0	WP 0546 (4 pages)	0
WP 0496 (2 pages)	0	WP 0547 (4 pages)	0
WP 0497 (4 pages)	0	WP 0548 (2 pages)	0
WP 0498 (2 pages)	0	WP 0549 (2 pages)	0
WP 0499 (10 pages)	0	WP 0550 (2 pages)	0
WP 0500 (10 pages)	0	WP 0551 (4 pages)	0
WP 0501 (4 pages)	0	WP 0552 (8 pages)	0
WP 0502 (6 pages)	0	WP 0553 (2 pages)	0
WP 0503 (10 pages)	0	Index 1 - Index 5/6 blank (6 pages)	0
WP 0504 (6 pages)	0	Inside Back Cover	0
WP 0505 (6 pages)	0	Back Cover	0
WP 0506 (6 pages)	0		
WP 0507 (4 pages)	0	VOLUME 4	
WP 0508 (6 pages)	0	Front Cover (2 pages)	0
WP 0509 (6 pages)	0	WARNING SUMMARY (10 pages)	0
WP 0510 (8 pages)	0	i-xxxvii/xxxviii blank (38 pages)	0
WP 0511 (4 pages)	0	Chapter 9 Title Page (2 pages)	0

LIST OF EFFECTIVE PAGES/WORK PACKAGES - Continued

Page/WP No.	Change No.	Page/WP No.	Change No.
WP 0554 (4 pages)	0	WP 0605 (8 pages)	0
WP 0555 (4 pages)	0	WP 0606 (2 pages)	0
WP 0556 (4 pages)	0	WP 0607 (4 pages)	0
WP 0557 (2 pages)	0	WP 0608 (4 pages)	0
WP 0558 (6 pages)	0	WP 0609 (4 pages)	0
WP 0559 (18 pages)	0	WP 0610 (2 pages)	0
WP 0560 (4 pages)	0	WP 0611 (4 pages)	0
WP 0561 (2 pages)	0	WP 0612 (4 pages)	0
WP 0562 (4 pages)	0	WP 0613 (4 pages)	0
WP 0563 (2 pages)	0	WP 0614 (6 pages)	0
WP 0564 (2 pages)	0	WP 0615 (4 pages)	0
WP 0565 (12 pages)	0	WP 0616 (4 pages)	0
WP 0566 (2 pages)	0	WP 0617 (4 pages)	0
WP 0567 (6 pages)	0	WP 0618 (2 pages)	0
WP 0568 (6 pages)	0	WP 0619 (2 pages)	0
WP 0569 (4 pages)	0	WP 0620 (4 pages)	0
WP 0570 (4 pages)	0	WP 0621 (6 pages)	0
WP 0571 (4 pages)	0	WP 0622 (2 pages)	0
WP 0572 (4 pages)	0	WP 0623 (4 pages)	0
WP 0573 (4 pages)	0	WP 0624 (2 pages)	0
WP 0574 (4 pages)	0	WP 0625 (4 pages)	0
WP 0575 (4 pages)	0	WP 0626 (4 pages)	0
WP 0576 (10 pages)	0	WP 0627 (6 pages)	0
WP 0577 (4 pages)	0	WP 0628 (4 pages)	0
WP 0578 (6 pages)	0	WP 0629 (6 pages)	0
WP 0579 (4 pages)	0	WP 0630 (16 pages)	0
WP 0580 (4 pages)	0	WP 0631 (6 pages)	0
WP 0581 (6 pages)	0	WP 0632 (10 pages)	0
WP 0582 (14 pages)	0	WP 0633 (6 pages)	0
WP 0583 (4 pages)	0	WP 0634 (4 pages)	0
WP 0584 (4 pages)	0	WP 0635 (6 pages)	0
WP 0585 (4 pages)	0	WP 0636 (6 pages)	0
WP 0586 (6 pages)	0	WP 0637 (6 pages)	0
WP 0587 (4 pages)	0	WP 0638 (4 pages)	0
WP 0588 (10 pages)	0	WP 0639 (32 pages)	0
WP 0589 (4 pages)	0	WP 0640 (4 pages)	0
WP 0590 (6 pages)	0	WP 0641 (6 pages)	0
WP 0591 (6 pages)	0	WP 0642 (4 pages)	0
WP 0592 (6 pages)	0	WP 0643 (4 pages)	0
WP 0593 (4 pages)	0	WP 0644 (2 pages)	0
WP 0594 (8 pages)	0	WP 0645 (6 pages)	0
WP 0595 (8 pages)	0	WP 0646 (4 pages)	0
WP 0596 (2 pages)	0	WP 0647 (6 pages)	0
WP 0597 (4 pages)	0	WP 0648 (4 pages)	0
WP 0598 (2 pages)	0	WP 0649 (2 pages)	0
WP 0599 (2 pages)	0	WP 0650 (10 pages)	0
WP 0600 (4 pages)	0	WP 0651 (10 pages)	0
WP 0601 (10 pages)	0	WP 0652 (10 pages)	0
WP 0602 (6 pages)	0	WP 0653 (6 pages)	0
WP 0603 (8 pages)	0	WP 0654 (6 pages)	0
WP 0604 (6 pages)	0	WP 0655 (8 pages)	0

LIST OF EFFECTIVE PAGES/WORK PACKAGES - Continued

Page/WP No.	Change No.	Page/WP No.	Change No.
WP 0656 (6 pages)	0	WP 0707 (10 pages)	0
WP 0657 (6 pages)	0	WP 0708 (4 pages)	0
WP 0658 (12 pages)	0	WP 0709 (8 pages)	0
WP 0659 (6 pages)	0	WP 0710 (4 pages)	0
WP 0660 (10 pages)	0	WP 0711 (6 pages)	0
WP 0661 (6 pages)	0	WP 0712 (6 pages)	0
WP 0662 (4 pages)	0	WP 0713 (8 pages)	0
WP 0663 (6 pages)	0	WP 0714 (4 pages)	0
WP 0664 (4 pages)	0	WP 0715 (10 pages)	0
WP 0665 (4 pages)	0	WP 0716 (6 pages)	0
WP 0666 (6 pages)	0	WP 0717 (12 pages)	0
WP 0667 (6 pages)	0	WP 0718 (4 pages)	0
WP 0668 (6 pages)	0	WP 0719 (2 pages)	0
WP 0669 (2 pages)	0	WP 0720 (2 pages)	0
WP 0670 (10 pages)	0	WP 0721 (6 pages)	0
WP 0671 (6 pages)	0	WP 0722 (10 pages)	0
WP 0672 (4 pages)	0	WP 0723 (4 pages)	0
WP 0673 (4 pages)	0	WP 0724 (8 pages)	0
WP 0674 (2 pages)	0	WP 0725 (24 pages)	0
WP 0675 (8 pages)	0	WP 0726 (6 pages)	0
WP 0676 (8 pages)	0	WP 0727 (6 pages)	0
WP 0677 (8 pages)	0	WP 0728 (10 pages)	0
WP 0678 (16 pages)	0	WP 0729 (6 pages)	0
WP 0679 (10 pages)	0	WP 0730 (6 pages)	0
WP 0680 (6 pages)	0	WP 0731 (4 pages)	0
WP 0681 (6 pages)	0	WP 0732 (4 pages)	0
WP 0682 (10 pages)	0	WP 0733 (2 pages)	0
WP 0683 (4 pages)	0	WP 0734 (2 pages)	0
WP 0684 (6 pages)	0	WP 0735 (6 pages)	0
WP 0685 (14 pages)	0	WP 0736 (6 pages)	0
WP 0686 (6 pages)	0	WP 0737 (8 pages)	0
WP 0687 (6 pages)	0	WP 0738 (6 pages)	0
WP 0688 (6 pages)	0	WP 0739 (6 pages)	0
WP 0689 (14 pages)	0	WP 0740 (2 pages)	0
WP 0690 (6 pages)	0	WP 0741 (4 pages)	0
WP 0691 (4 pages)	0	WP 0742 (4 pages)	0
WP 0692 (8 pages)	0	WP 0743 (4 pages)	0
WP 0693 (6 pages)	0	WP 0744 (2 pages)	0
WP 0694 (6 pages)	0	WP 0745 (6 pages)	0
WP 0695 (6 pages)	0	WP 0746 (6 pages)	0
WP 0696 (22 pages)	0	WP 0747 (6 pages)	0
WP 0697 (4 pages)	0	WP 0748 (6 pages)	0
WP 0698 (18 pages)	0	WP 0749 (2 pages)	0
WP 0699 (6 pages)	0	WP 0750 (6 pages)	0
WP 0700 (6 pages)	0	WP 0751 (4 pages)	0
WP 0701 (6 pages)	0	WP 0752 (6 pages)	0
WP 0702 (12 pages)	0	WP 0753 (4 pages)	0
WP 0703 (10 pages)	0	WP 0754 (6 pages)	0
WP 0704 (6 pages)	0	WP 0755 (6 pages)	0
WP 0705 (4 pages)	0	WP 0756 (4 pages)	0
WP 0706 (6 pages)	0	WP 0757 (12 pages)	0

LIST OF EFFECTIVE PAGES/WORK PACKAGES - Continued

Page/WP No.	Change No.	Page/WP No.	Change No.
WP 0758 (6 pages)	0	WP 0792 (6 pages)	0
WP 0759 (4 pages)	0	WP 0793 (6 pages)	0
WP 0760 (6 pages)	0	WP 0794 (6 pages)	0
WP 0761 (6 pages)	0	WP 0795 (6 pages)	0
WP 0762 (6 pages)	0	WP 0796 (6 pages)	0
WP 0763 (6 pages)	0	WP 0797 (6 pages)	0
WP 0764 (6 pages)	0	WP 0798 (6 pages)	0
WP 0765 (6 pages)	0	WP 0799 (6 pages)	0
WP 0766 (4 pages)	0	WP 0800 (6 pages)	0
WP 0767 (4 pages)	0	WP 0801 (10 pages)	0
WP 0768 (6 pages)	0	WP 0802 (10 pages)	0
WP 0769 (10 pages)	0	WP 0803 (4 pages)	0
WP 0770 (10 pages)	0	WP 0804 (6 pages)	0
Index-1 - Index-6 (6 pages)	0	WP 0805 (2 pages)	0
Inside Back Cover	0	WP 0806 (20 pages)	0
Back Cover	0	WP 0807 (6 pages)	0
		WP 0808 (4 pages)	0
VOLUME 5		WP 0809 (8 pages)	0
Front Cover (2 pages)	0	WP 0810 (10 pages)	0
WARNING SUMMARY (10 pages)	0	WP 0811 (6 pages)	0
i-xvii/xviii blank (18 pages)	0	WP 0812 (10 pages)	0
Chapter 10 Title Page (2 pages)	0	WP 0813 (2 pages)	0
WP 0771 (4 pages)	0	WP 0814 (8 pages)	0
WP 0772 (10 pages)	0	WP 0815 (4 pages)	0
WP 0773 (4 pages)	0	WP 0816 (2 pages)	0
WP 0774 (12 pages)	0	WP 0817 (4 pages)	0
WP 0775 (42 pages)	0	WP 0818 (6 pages)	0
WP 0776 (10 pages)	0	WP 0819 (8 pages)	0
WP 0777 (4 pages)	0	WP 0820 (34 pages)	0
WP 0778 (6 pages)	0	WP 0821 (10 pages)	0
WP 0779 (6 pages)	0	Chapter 11 Title Page (2 pages)	0
WP 0780 (4 pages)	0	WP 0822 (4 pages)	0
WP 0781 (6 pages)	0	WP 0823 (4 pages)	0
WP 0782 (6 pages)	0	WP 0824 (78 pages)	0
WP 0783 (10 pages)	0	WP 0825 (8 pages)	0
WP 0784 (12 pages)	0	WP 0826 (4 pages)	0
WP 0785 (8 pages)	0	WP 0827 (26 pages)	0
WP 0786 (6 pages)	0	WP 0828 (2 pages)	0
WP 0787 (8 pages)	0	Index 1 - Index 20 (20 pages)	0
WP 0788 (12 pages)	0	FP-1 - FP-27/FP-28 blank	0
WP 0789 (2 pages)	0	(28 pages)	0
WP 0790 (10 pages)	0	Inside Back Cover	0
WP 0791 (6 pages)	0	Back Cover	0

HEADQUARTERS
DEPARTMENTS OF THE ARMY AND THE AIR FORCE
WASHINGTON, D.C., 10 SEPTEMBER 2012

TECHNICAL MANUAL
FIELD MAINTENANCE MANUAL
FOR

TRUCK, 5-TON, 6X6, M939, M939A1, AND M939A2 SERIES TRUCKS (DIESEL)

TRUCK, CARGO: 5-TON, 6X6 DROPSIDERUCK, DUMP: 5-TON, 6X6	TRUCK, VAN, EXPANSIBLE: 5-TON, 6X6
M923	M934
NSN 2320-01-050-2084 (EIC BRY)	NSN 2320-01-047-8750 (EIC BTB)
M923A1	M934A1
NSN 2320-01-206-4087 (EIC BSS)	NSN 2320-01-205-2682 (EIC BS4)
M923A2	M934A2
NSN 2320-01-230-0307 (EIC BS7)	NSN 2320-01-230-0300 (EIC BTR)
M925	
NSN 2320-01-047-8769 (EIC BRT)	TRUCK, MEDIUM WRECKER: 5-TON, 6X6
M925A1	M936
NSN 2320-01-206-4088 (EIC BST)	NSN 2320-01-047-8754 (EIC BTF)
M925A2	M936A1
NSN 2320-01-230-0308 (EIC BS8)	NSN 2320-01-206-4078 (EIC BS6)
	M936A2
TRUCK, CARGO: 5-TON, 6X6 XLWBTRUCK, TRACTOR: 5-TON, 6X6	NSN 2320-01-230-0304 (EIC BTT)
M927	M931
NSN 2320-01-047-8771 (EIC BRV)	NSN 2320-01-047-8753 (EIC BTE)
M927A1	M931A1
NSN 2320-01-206-4089 (EIC BSW)	NSN 2320-01-206-4077 (EIC BS2)
M927A2	M931A2
NSN 2320-01-230-0309 (EIC BS9)	NSN 2320-01-230-0302 (EIC BTP)
M928	M932
NSN 2320-01-047-8770 (EIC BRU)	NSN 2320-01-047-8752 (EIC BTD)
M928A1	M932A1
NSN 2320-01-206-4090 (EIC BSX)	NSN 2320-01-205-2684 (EIC BSZ)
M928A2	M932A2
NSN 2320-01-230-0310 (EIC BTM)	NSN 2320-01-230-0303 (EIC BTQ)

REPORTING ERRORS AND RECOMMENDING IMPROVEMENTS

You can help improve this publication. If you find any mistakes, or if you know of a way to improve the procedures, please let us know: Reports, as applicable by the requiring service, should be submitted as follows:

(A) Army - Mail your letter or DA Form 2028 (Recommended Changes to Publications and Blank Forms), located in the back of this manual directly to: U.S. Army TACOM Life Cycle Management Command, ATTN: AMSTA-LCL-MPP/ TECH PUBS, MS 727, 6501 E. 11 Mile Road, Warren, MI 48397-5000. You may also send in your recommended changes via electronic mail or by fax. Our fax number is DSN 786-1856 or Commercial (586) 282-1856. Our email address is tacomlcmc.daform2028@us.army.mil.

(F) Air Force - By Air Force AFTO Form 22 directly to WR/ALC/GRVEB, Robins GA. You may also send in your recommended changes electronically via email. Email AFTO form 22 to robins.ce.afto22@robins.af.mil. A reply will be furnished to you.

***SUPERSEDURE NOTICE** - This manual supersedes TM 9-2320-272-24-1, TM 9-2320-272-24-2, TM 9-2320-272-24-3, TM 9-2320-272-24-4 and TO 36A12-1C-1155-2-1, TO 36A12-1C-1155-2-2, TO 36A12-1C-1155-2-3, & TO 36A12-1C-1155-2-4, dated 30 June 1998, including all changes

DISTRIBUTION STATEMENT A - Approved for public release; distribution is unlimited.

TABLE OF CONTENTS

Page No.
WP Sequence No.

Volume 1

HOW TO USE THIS MANUAL cli

Chapter 1 - GENERAL INFORMATION, EQUIPMENT DESCRIPTION, AND THEORY OF OPERATION

GENERAL INFORMATION..... WP 0001

Table 1. Hazardous Materials..... 0001-2

Table 2. List of Abbreviations/Acronyms..... 0001-3

EQUIPMENT DESCRIPTION AND DATA..... WP 0002

Figure 1. M923 Cargo Truck..... 0002-2

Figure 2. M925 Cargo Truck..... 0002-3

Figure 3. M927 Extra Long Wheelbase Cargo Truck..... 0002-4

Figure 4. M928 Extra Long Wheelbase Cargo Truck..... 0002-5

Figure 5. M929 Dump Truck..... 0002-6

Figure 6. M930 Dump Truck..... 0002-7

Figure 7. M931 Tractor Truck..... 0002-8

Figure 8. M932 Tractor Truck..... 0002-9

Figure 9. M934 Expansible Vans..... 0002-10

Figure 10. M936 Medium Wreckers..... 0002-11

Figure 11. Location Of Exterior Major Components..... 0002-12

Table 1. Description of Exterior Major Components..... 0002-13

Figure 12. Description of Interior Cab Components..... 0002-15

Table 2. Description of Interior Cab Components..... 0002-16

Table 3. Differences Between Models..... 0002-17

Table 4. Vehicle Performance Data..... 0002-19

THEORY OF OPERATION..... WP 0003

Figure 1. Starting and Ether Starting Components..... 0003-2

Figure 2. Starting and Ether Starting Components..... 0003-3

Figure 3. Accelerator Controls System Components..... 0003-4

TABLE OF CONTENTS - Continued

	Page No.
	<u>WP Sequence No.</u>
Figure 4. Parking Brake System Components.....	0003-5
Figure 5. Steering System Components.....	0003-6
Figure 6. Transmission Control System Components.....	0003-7
Figure 7. Transfer Case Control System Components.....	0003-9
Figure 8. Transfer Case Control System Components.....	0003-10
Figure 9. Air Intake System Components.....	0003-13
Figure 10. Fuel System (Dual Tank) Components.....	0003-15
Figure 11. Fuel System (Single Tank) Components.....	0003-16
Figure 12. Exhaust System Components.....	0003-17
Figure 13. Cooling System Components.....	0003-19
Figure 14. Engine Oil System Components.....	0003-21
Figure 15. Engine Oil System Components.....	0003-22
Figure 16. Powertrain System Components.....	0003-23
Figure 17. Battery System Components.....	0003-25
Figure 18. Starting System Components.....	0003-26
Figure 19. Ether Starting System Components.....	0003-27
Figure 20. Generating System Components.....	0003-28
Figure 21. Directional Signal System Components.....	0003-29
Figure 22. Heating System Components.....	0003-31
Figure 23. Indicator, Gauge, and Warning System Components.....	0003-33
Figure 24. Trailer and Semitrailer Connection Components.....	0003-34
Figure 25. Medium Wrecker Automatic Brake Lock System Components.....	0003-35
Figure 26. Air Pressure Supply System Components.....	0003-37
Figure 27. Constant Air Pressure Supply System Components.....	0003-39
Figure 28. Secondary Service Airbrake System Components.....	0003-41
Figure 29. Spring Airbrake System Components.....	0003-43
Figure 30. Primary Service Airbrake System Components.....	0003-45

TABLE OF CONTENTS - Continued

	Page No.
	<u>WP Sequence No.</u>
Figure 31. Auxiliary Air-Powered System Components.....	0003-47
Figure 32. Air Venting System Components.....	0003-49
Figure 33. Central Tire Inflation System Components.....	0003-51
Figure 34. Front Winch Hydraulic System Components.....	0003-52
Figure 35. Rear Winch Hydraulic System Components.....	0003-53
Figure 36. Dump Body Hydraulic System Components.....	0003-55
Figure 37. Medium Wrecker Crane Hydraulic System Components.....	0003-57
Figure 38. Hoist Action Components.....	0003-58
Figure 39. Crowd Action Components.....	0003-59
Figure 40. Swing Action Components.....	0003-60
 Chapter 2 - GENERAL TROUBLESHOOTING PROCEDURES	
GENERAL TROUBLESHOOTING.....	WP 0004
GENERAL TROUBLESHOOTING INDEX.....	WP 0005
ENGINE FAILS TO CRANK.....	WP 0006
Figure 1. Battery Cables.....	0006-2
Figure 2. Battery Specific Gravity Test.....	0006-3
Figure 3. Starter Cables.....	0006-4
Figure 4. DCA Connection.....	0006-5
Figure 5. Starter Solenoid.....	0006-6
Figure 6. Starter Motor.....	0006-6
Figure 7. Starter Motor.....	0006-7
Figure 8. Starter Motor.....	0006-8
ENGINE CRANKS BUT DOES NOT START.....	WP 0007
Figure 1. Engine Stop Control.....	0007-2
Figure 2. Air Cleaner Indicator.....	0007-2
Figure 3. Engine Exhaust.....	0007-3
Figure 4. Engine Exhaust.....	0007-4

TABLE OF CONTENTS - Continued

	Page No.
	<u>WP Sequence No.</u>
Figure 5. Engine Dipstick.....	0007-5
Figure 6. Engine Fuel Supply Line.....	0007-6
Figure 7. Fuel Transfer Pump.....	0007-7
Figure 8. Fuel Pressure Transducer.....	0007-8
Figure 9. Fuel Injector Supply Lines.....	0007-9
Figure 10. Fuel Filter.....	0007-10
Figure 11. Fuel System.....	0007-11
Figure 12. Engine.....	0007-12
Figure 13. Fuel Filter.....	0007-13
Figure 14. Fuel Filter.....	0007-14
Figure 15. Fuel Tank.....	0007-15
Figure 16. Ether Start System.....	0007-16
Figure 17. Ether Start System.....	0007-17
Figure 18. Thermal Close Valve.....	0007-18
Figure 19. Thermal Close Valve.....	0007-19
Figure 20. Thermal Close Valve.....	0007-20
Figure 21. Thermal Close Valve.....	0007-21
STARTER CRANKS ENGINE SLOWLY, HARD TO START.....	WP 0008
Figure 1. Engine.....	0008-2
Figure 2. Accelerator Pedal.....	0008-3
ENGINE STOPS DURING NORMAL OPERATION.....	WP 0009
Figure 1. Air Cleaner Indicator.....	0009-2
Figure 2. Fuel Tank.....	0009-3
Figure 3. Emergency Shutoff Valve.....	0009-4
Figure 4. Fuel Filter.....	0009-5
Figure 5. Fuel Tank.....	0009-6
Figure 6. Fuel Line.....	0009-7

TABLE OF CONTENTS - Continued

	Page No.
	<u>WP Sequence No.</u>
Figure 7. Fuel System.....	0009-8
Figure 8. Vent Lines.....	0009-9
Figure 9. Exhaust System.....	0009-10
ENGINE STOPS WHEN ACCELERATOR IS RETURNED TO IDLE POSITION.....	WP 0010
Figure 1. Accelerator Linkage.....	0010-2
Figure 2. Tachometer.....	0010-3
ENGINE FAILS TO STOP.....	WP 0011
Figure 1. Emergency Stop Cable.....	0011-2
Figure 2. Throttle Control Solenoid.....	0011-3
ENGINE RUNS, BUT MISFIRES.....	WP 0012
Figure 1. Fuel Filter.....	0012-2
Figure 2. Fuel Tank.....	0012-3
Figure 3. Air Cleaner Indicator.....	0012-4
Figure 4. Throttle Linkage.....	0012-5
Figure 5. Fuel Lines.....	0012-6
ENGINE IDLE ROUGH OR ERRATIC.....	WP 0013
Figure 1. Injector Tubes.....	0013-2
Figure 2. Injector Tubes.....	0013-3
POOR ACCELERATION AND/OR LACK OF POWER.....	WP 0014
Figure 1. Air Cleaner Indicator.....	0014-2
Figure 2. Fuel System.....	0014-3
Figure 3. Exhaust System.....	0014-4
Figure 4. Accelerator Cable.....	0014-5
Figure 5. Accelerator Cable.....	0014-6
Figure 6. Modulator Cable.....	0014-7
Figure 7. Air Fuel Control Tube.....	0014-8
Figure 8. Exhaust System.....	0014-9

TABLE OF CONTENTS - Continued

	Page No.
	<u>WP Sequence No.</u>
Figure 9. Fuel Transfer Pump.....	0014-10
Figure 10. Fuel Pressure Transducer.....	0014-11
Figure 11. Fuel Injector Supply Line.....	0014-12
Figure 12. Fuel Filter.....	0014-13
Figure 13. Turbocharger.....	0014-14
ENGINE SURGES.....	WP 0015
Figure 1. Fuel Tank.....	0015-2
Figure 2. Modulator Cable.....	0015-3
Figure 3. Throttle Linkage.....	0015-4
EXCESSIVE OIL CONSUMPTION.....	WP 0016
Figure 1. Oil Dipstick.....	0016-2
Figure 2. Engine.....	0016-3
Figure 3. Turbocharger.....	0016-4
LOW OIL PRESSURE.....	WP 0017
Figure 1. Engine Oil Lines.....	0017-2
Figure 2. Oil Filter.....	0017-3
Figure 3. Engine Oil Pressure Sending Unit.....	0017-4
ENGINE OIL CONTAMINATED.....	WP 0018
Figure 1. Oil Sample.....	0018-2
Figure 2. Fuel Transfer Pump.....	0018-3
Figure 3. Engine Oil Cooler and Aftercooler.....	0018-4
EXCESSIVE VIBRATION OR CLUNKING.....	WP 0019
EXCESSIVE FUEL CONSUMPTION.....	WP 0020
Figure 1. Air Cleaner Indicator.....	0020-1
Figure 2. Fuel System.....	0020-2
ENGINE CRANKS BUT WILL NOT START IN COLD WEATHER (FUEL SYSTEM OPERATING PROPERLY).....	WP 0021
Figure 1. Ether Cylinder.....	0021-2

TABLE OF CONTENTS - Continued

	Page No.
	<u>WP Sequence No.</u>
Figure 2. Ether Valve.....	0021-3
Figure 3. Ether Valve Circuit 570 Wire.....	0021-4
Figure 4. Fuel Pressure Switch Circuit 570 Wire.....	0021-6
Figure 5. Ether Start Switch Circuit 570 Wire.....	0021-8
Figure 6. Ether Start Switch Circuit 5C Wire.....	0021-10
Figure 7. Ether Valve.....	0021-12
Figure 8. Thermal Close Valve.....	0021-14
Figure 9. Atomizer.....	0021-15
EXHAUST COLOR BLUE DURING NORMAL OPERATION.....	WP 0022
EXHAUST COLOR WHITE DURING NORMAL OPERATION.....	WP 0023
Figure 1. Fuel Filter.....	0023-2
EXHAUST COLOR BLACK DURING NORMAL OPERATION AND IDLE.....	WP 0024
Figure 1. Fuel Filter.....	0024-2
Figure 2. Fuel Filter.....	0024-3
Figure 3. Fuel Tank.....	0024-4
Figure 4. Air Cleaner Indicator.....	0024-5
EXCESSIVE EXHAUST NOISE.....	WP 0025
Figure 1. Muffler.....	0025-2
Figure 2. Exhaust System (M939/A1).....	0025-3
Figure 3. Exhaust System (M939A2).....	0025-4
EXHAUST FUMES IN CAB.....	WP 0026
Figure 1. Exhaust System (M939/A1).....	0026-2
Figure 2. Exhaust System (M939A2).....	0026-3
Figure 3. Exhaust System.....	0026-4
ENGINE DOES NOT REACH NORMAL OPERATING TEMPERATURE.....	WP 0027
Figure 1. Surge Tank.....	0027-2
Figure 2. Fan Clutch.....	0027-3

TABLE OF CONTENTS - Continued

	Page No.
	<u>WP Sequence No.</u>
Figure 3. Coolant Temperature Sending Unit.....	0027-4
ENGINE OVERHEATS.....	WP 0028
Figure 1. Surge Tank.....	0028-2
Figure 2. Engine Oil Dipstick.....	0028-3
Figure 3. Engine Drive Belt.....	0028-4
Figure 4. Engine Cooling System (M939/A1).....	0028-6
Figure 5. Engine Cooling System (M939A2).....	0028-7
Figure 6. Engine Cooling System (M939/A1).....	0028-8
Figure 7. Engine Cooling System (M939A2).....	0028-9
Figure 8. Engine Cooling Fan.....	0028-10
Figure 9. Radiator.....	0028-11
Figure 10. Air Pressure Gauge.....	0028-12
Figure 11. Fan Clutch Actuator.....	0028-13
Figure 12. Water Pump.....	0028-14
Figure 13. Test Lead Hookup.....	0028-15
LOSS OF COOLANT.....	WP 0029
Figure 1. Engine Cooling System (M939/A1).....	0029-2
Figure 2. Engine Cooling System (M939A2).....	0029-3
Figure 3. Transmission Oil Cooler.....	0029-4
Figure 4. Surge Tank.....	0029-6
CONTAMINATED COOLANT.....	WP 0030
Figure 1. Surge Tank.....	0030-2
EXCESSIVE NOISE DURING SHIFTING.....	WP 0031
Figure 1. Transmission Dipstick.....	0031-2
Figure 2. Transmission Dipstick.....	0031-3
Figure 3. Transmission Yoke.....	0031-4
Figure 4. Transmission Universal Joints.....	0031-5

TABLE OF CONTENTS - Continued

	Page No.
	<u>WP Sequence No.</u>
LOW TRANSMISSION OIL PRESSURE.....	WP 0032
Figure 1. Transmission Dipstick.....	0032-2
TRANSMISSION OIL LEAKING.....	WP 0033
Figure 1. Transmission Oil Pan.....	0033-2
Figure 2. Transmission Oil Cooling Lines.....	0033-3
NO RESPONSE TO SHIFT LEVER MOVEMENT.....	WP 0034
Figure 1. Transmission Dipstick.....	0034-2
Figure 2. Transmission Selector.....	0034-3
ROUGH SHIFTING.....	WP 0035
Figure 1. Transmission Dipstick.....	0035-2
Figure 2. Transmission Selector.....	0035-3
TRANSMISSION OVERHEATS AS INDICATED BY TRANSMISSION TEMPERATURE GAUGE.....	WP 0036
Figure 1. Transmission Dipstick.....	0036-2
Figure 2. Test Lead Hookup.....	0036-3
DIRT OR METAL PARTICLES IN TRANSMISSION OIL.....	WP 0037
Figure 1. Transmission Oil Sample Port.....	0037-2
OIL THROWN FROM TRANSMISSION DIPSTICK TUBE.....	WP 0038
Figure 1. Transmission Dipstick.....	0038-2
Figure 2. Transmission Dipstick.....	0038-3
TRANSMISSION OIL DIRTY, FOAMY, AND/OR MILKY.....	WP 0039
Figure 1. Transmission Dipstick.....	0039-2
Figure 2. Transmission Dipstick.....	0039-3
Figure 3. Transmission Dipstick.....	0039-4
Figure 4. Transmission Dipstick.....	0039-5
HARD SHIFTING OF TRANSFER CASE.....	WP 0040
Figure 1. Transfer Case.....	0040-2
Figure 2. Transfer Case Linkage.....	0040-3

TABLE OF CONTENTS - Continued

	Page No.
	<u>WP Sequence No.</u>
Figure 3. Circuit 586 Wire.....	0040-4
Figure 4. Circuit 585 Wire.....	0040-5
Figure 5. Circuit 37 Breaker.....	0040-6
Figure 6. Circuit 10 Breaker.....	0040-7
TRANSFER CASE LEAKING OIL.....	WP 0041
Figure 1. Transfer Case.....	0041-2
EXCESSIVE NOISE.....	WP 0042
Figure 1. Transfer Case.....	0042-2
EXCESSIVE VIBRATION.....	WP 0043
Figure 1. Transfer Case.....	0043-2
Figure 2. Propeller Shafts.....	0043-3
EXCESSIVE PROPELLER AND DRIVE SHAFTS NOISE OR VIBRATION.....	WP 0044
Figure 1. Universal Joints.....	0044-2
Figure 2. Propeller Shaft.....	0044-3
Figure 3. Center Bearing.....	0044-4
CONTINUOUS AXLE OR WHEEL NOISE.....	WP 0045
Figure 1. Front Wheel Drive Lock-In Switch.....	0045-2
Figure 2. Wheel Lug Nuts.....	0045-3
Figure 3. Differential Lubrication Level.....	0045-4
Figure 4. Wheel Bearings.....	0045-5
TOWING PINTLE DOES NOT LATCH OR LOCK.....	WP 0046
Figure 1. Pintle Hook Assembly.....	0046-2
Figure 2. Pintle Hook Assembly.....	0046-3
PINTLE HOOK DOES NOT TURN.....	WP 0047
Figure 1. Pintle Hook Assembly.....	0047-2
Figure 2. Pintle Hook Mounting Housing Bracket.....	0047-3
Figure 3. Pintle Hook Shaft.....	0047-4

TABLE OF CONTENTS - Continued

	Page No.
	<u>WP Sequence No.</u>
EXCESSIVELY LOOSE LIFTING SHACKLE.....	WP 0048
Figure 1. Front and Rear Shackle Pin Assembly.....	0048-2
Figure 2. Front and Rear Shackle Pin Assembly.....	0048-3
Figure 3. Front and Rear Shackle Pin Assembly.....	0048-4
Figure 4. Front and Rear Shackle Pin Assembly.....	0048-5
LOOSE SPARE TIRE CARRIER.....	WP 0049
Figure 1. Spare Tire Carrier.....	0049-2
Figure 2. Spare Tire Carrier Assembly.....	0049-3
UNEVEN TIRE WEAR.....	WP 0050
Figure 1. Lugnuts.....	0050-2
Figure 2. Toe-In Adjustment.....	0050-3
Figure 3. Wheel Bearing Assembly.....	0050-4
WHEEL SHIMMY OR WOBBLE.....	WP 0051
Figure 1. Wheel.....	0051-2
Figure 2. Wheel Bearing Assembly.....	0051-3
HARD STEERING.....	WP 0052
Figure 1. Steering Hydraulic Lines.....	0052-2
Figure 2. Steering Assembly.....	0052-3
Figure 3. Pitman Arm.....	0052-4
Figure 4. Spring U-Bolts.....	0052-5
Figure 5. Toe-In Check.....	0052-6
VEHICLE WANDERS OR PULLS TO ONE SIDE.....	WP 0053
Figure 1. Tire.....	0053-2
Figure 2. Front Wheel Assembly.....	0053-3
Figure 3. Truck Jack.....	0053-4
Figure 4. Wheel Bearing Assembly.....	0053-5
Figure 5. Steering Assist Cylinder.....	0053-6

TABLE OF CONTENTS - Continued

	Page No.
	<u>WP Sequence No.</u>
Figure 6. Tie Rod.....	0053-7
Figure 7. Steering Gear.....	0053-8
Figure 8. Pitman Arm.....	0053-9
Figure 9. Shackle Pins.....	0053-10
Figure 10. Toe-In Check.....	0053-11
EXCESSIVE PLAY IN STEERING WHEEL.....	WP 0054
Figure 1. Steering Wheel.....	0054-2
Figure 2. Drag Link.....	0054-3
Figure 3. Tie Rod.....	0054-4
Figure 4. Pitman Arm.....	0054-5
Figure 5. Steering Assist Cylinder.....	0054-6
SHIMMY.....	WP 0055
Figure 1. Wheel Lugnuts.....	0055-2
Figure 2. Wheels.....	0055-3
Figure 3. Wheel Bearing Assembly.....	0055-4
Figure 4. Toe-In Check.....	0055-5
Figure 5. Steering Knuckle.....	0055-6
CONTINUOUS WANDERING OR SWAYING (POOR CONTROL).....	WP 0056
Figure 1. Leaf Springs.....	0056-2
Figure 2. Shock Absorber.....	0056-3
Figure 3. U-Bolts.....	0056-4
HARSH OR HARD RIDE.....	WP 0057
Figure 1. Leaf Springs, Pivots, and Shackle Pins.....	0057-2
Figure 2. Spring Shackles.....	0057-3
Figure 3. Shock Absorbers.....	0057-4
SPRING LEAF DEFECT.....	WP 0058
Figure 1. Spring Shackles.....	0058-2

TABLE OF CONTENTS - Continued

	Page No.
	<u>WP Sequence No.</u>
Figure 2. U-Bolts.....	0058-3
Figure 3. Leaf Springs and Shackle Pins.....	0058-4
WINCH DOES NOT OPERATE.....	WP 0059
Figure 1. Hydraulic Oil Check.....	0059-2
Figure 2. Power Takeoff Controls.....	0059-3
Figure 3. Power Takeoff Linkage.....	0059-4
Figure 4. Front Winch.....	0059-5
Figure 5. Front Winch Drum Lock.....	0059-6
Figure 6. Front Winch.....	0059-7
Figure 7. Oil Lines.....	0059-8
Figure 8. Oil Return Line.....	0059-9
Figure 9. Oil Filter.....	0059-10
Figure 10. Oil Pump.....	0059-11
Figure 11. Winch Motor.....	0059-12
WINCH OPERATES IN ONE DIRECTION ONLY.....	WP 0060
Figure 1. Front Winch.....	0060-2
Figure 2. Control Valve.....	0060-3
Figure 3. Air Operator Tensioner.....	0060-4
Figure 4. Winch Torque Control Lever.....	0060-5
DRAG BRAKE DOES NOT OPERATE.....	WP 0061
Figure 1. Front Winch.....	0061-2
Figure 2. Front Winch.....	0061-3
WINCH WILL NOT HOLD LOAD.....	WP 0062
Figure 1. Torque Control Lever.....	0062-2
Figure 2. Front And Rear Winches.....	0062-3
AUTOMATIC BRAKE OVERHEATS.....	WP 0063
Figure 1. Front and Rear Winch.....	0063-2

TABLE OF CONTENTS - Continued

	Page No.
	<u>WP Sequence No.</u>
Figure 2. Automatic Brake Setscrew.....	0063-3
FRONT WINCH OPERATES AT ONE SPEED ONLY.....	WP 0064
Figure 1. Winch Control Valve.....	0064-2
Figure 2. Front Winch.....	0064-3
Figure 3. Throttle Control Cable.....	0064-4
REAR WINCH CABLE TENSIONER WILL NOT OPERATE.....	WP 0065
Figure 1. Rear Winch Cable Tensioner.....	0065-2
VEHICLE ROLLS WHILE OPERATING REAR WINCH.....	WP 0066
Figure 1. Spring Brake.....	0066-2
Figure 2. Field Chocks.....	0066-3
PTO EXCESSIVELY NOISY.....	WP 0067
Figure 1. PTO Universal Joint.....	0067-2
Figure 2. Transmission PTO to Hydraulic Pump Propeller Shaft.....	0067-3
Figure 3. Transfer Case PTO to Hydraulic Pump Propeller Shaft.....	0067-4
PTO SHIFTS HARD.....	WP 0068
Figure 1. PTO Shift Linkage.....	0068-2
Figure 2. PTO Shift Linkage Condition.....	0068-4
PTO LEAKING LUBRICANT.....	WP 0069
Figure 1. PTO Mounting Screws.....	0069-2
RADIO INTERFERENCE.....	WP 0070
Figure 1. Alternator Wiring.....	0070-2
Figure 2. Alternator.....	0070-3
TRAILER WILL NOT HITCH TO FIFTH WHEEL.....	WP 0071
Figure 1. Fifth Wheel.....	0071-2
WRECKER HYDRAULIC SYSTEM DOES NOT OPERATE.....	WP 0072
Figure 1. Hydraulic Oil Reservoir.....	0072-2
Figure 2. Power Takeoff Controls.....	0072-3

TABLE OF CONTENTS - Continued

	Page No.
	<u>WP Sequence No.</u>
Figure 3. Oil Lines.....	0072-4
WRECKER HYDRAULIC PUMP NOISY.....	WP 0073
Figure 1. Hydraulic Oil Level.....	0073-2
DUMP BODY WILL NOT RAISE.....	WP 0074
Figure 1. Power Takeoff Controls.....	0074-2
Figure 2. Hydraulic Lines.....	0074-3
Figure 3. Control Valve.....	0074-4
Figure 4. Control Valve Movement.....	0074-4
Figure 5. Pump Housing.....	0074-5
DUMP BODY WILL NOT LOWER.....	WP 0075
Figure 1. Dump Body Brace.....	0075-2
Figure 2. Control Valve.....	0075-3
DUMP BODY WILL NOT HOLD IN RAISED POSITION.....	WP 0076
Figure 1. Hydraulic Lines.....	0076-2
Figure 2. Control Valve.....	0076-3
DUMP HYDRAULIC PUMP NOISY.....	WP 0077
Figure 1. Hydraulic Oil Level.....	0077-2
TAILGATE WILL NOT OPEN	WP 0078
Figure 1. Tailgate Linkage.....	0078-2
SIDE PANELS HARD TO RETRACT OR EXPAND.....	WP 0079
Figure 1. Sprocket Assembly.....	0079-2
Figure 2. Rollers.....	0079-3
SIDE PANEL CANNOT BE LOCKED IN RETRACT POSITION.....	WP 0080
Figure 1. Side Panel.....	0080-2
Figure 2. Roof Edge.....	0080-3
VAN BODY NOT WATERPROOF OR LIGHT TIGHT.....	WP 0081
Figure 1. Side Panel.....	0081-2

TABLE OF CONTENTS - Continued

	Page No.
	<u>WP Sequence No.</u>
Figure 2. End Panel.....	0081-3
Figure 3. Block Seal.....	0081-4
Figure 4. Rear Door Seal.....	0081-5
DOOR LOCK WILL NOT OPERATE.....	WP 0082
Figure 1. Door Lock.....	0082-2
Figure 2. Striker Plate.....	0082-3
ENGINE AND VEHICLE ELECTRICAL SYSTEMS MALFUNCTIONING.....	WP 0083
Figure 1. Protective Control Box.....	0083-2
ENGINE WILL NOT CRANK; SOME ELECTRICAL SYSTEMS INOPERATIVE OR WEAK.....	WP 0084
Figure 1. Batteries.....	0084-2
Figure 2. Battery Terminals.....	0084-3
Figure 3. Specific Gravity Test.....	0084-4
Figure 4. Specific Gravity Test.....	0084-5
Figure 5. Battery/Solenoid Voltage Test.....	0084-6
ALL VEHICLE ELECTRICAL SYSTEMS INOPERATIVE.....	WP 0085
Figure 1. Battery Terminals.....	0085-2
Figure 2. Battery Terminals.....	0085-3
Figure 3. Battery Terminals.....	0085-4
Figure 4. Specific Gravity Test.....	0085-5
Figure 5. Specific Gravity Test.....	0085-6
Figure 6. Protection Control Box Test.....	0085-7
STARTER MOTOR INOPERATIVE.....	WP 0086
Figure 1. Battery and Starter Switches.....	0086-2
Figure 2. Battery/Solenoid Voltage Test.....	0086-3
SOLENOID OPERATES, STARTER OPERATES, BUT ENGINE CRANKS SLOWLY.....	WP 0087
Figure 1. Engine Stop Control Switch.....	0087-2
Figure 2. Specific Gravity Test.....	0087-3

TABLE OF CONTENTS - Continued

	Page No.
	<u>WP Sequence No.</u>
Figure 3. Specific Gravity Test.....	0087-4
Figure 4. Battery/Solenoid Voltage Test.....	0087-5
Figure 5. Starter Motor To Solenoid Voltage Drop Test.....	0087-6
Figure 6. Starter Motor Solenoid Voltage Drop Test.....	0087-7
Figure 7. Starter Motor Ground Voltage Drop Test.....	0087-8
Figure 8. Starter Motor Cable Voltage Drop Test.....	0087-9
STARTER MOTOR INOPERATIVE; NO SOLENOID THUMP.....	WP 0088
Figure 1. Light Switch.....	0088-2
Figure 2. Protective Control Box.....	0088-3
Figure 3. Battery Switch Wire 81A.....	0088-4
Figure 4. Battery Switch Test.....	0088-5
Figure 5. Protective Control Box Wire 459.....	0088-6
Figure 6. Protective Control Box Wire 81.....	0088-7
Figure 7. Starter Solenoid Wire 74.....	0088-8
Figure 8. Start Switch Wire 5B.....	0088-9
Figure 9. Start Switch.....	0088-10
Figure 10. Neutral Start Switch Wire 498.....	0088-11
Figure 11. Neutral Start Switch.....	0088-12
Figure 12. Protective Control Box Wire 499.....	0088-13
Figure 13. Alternator Wire 566.....	0088-14
Figure 14. Protective Control Box.....	0088-15
NO OR LOW ALTERNATOR OUTPUT.....	WP 0089
Figure 1. Alternator Drive Belt.....	0089-2
Figure 2. DCA Connector.....	0089-3
Figure 3. Alternator Electrical Wiring.....	0089-4
Figure 4. Alternator Wire 568.....	0089-5
Figure 5. Alternator Wiring.....	0089-6

TABLE OF CONTENTS - Continued

	Page No.
	<u>WP Sequence No.</u>
Figure 6. Alternator Wire 5.....	0089-7
Figure 7. Alternator Wire 5/568.....	0089-8
NO ALTERNATOR OUTPUT (100 AMP ALTERNATOR).....	WP 0090
Figure 1. Alternator Drive Belt.....	0090-2
Figure 2. DCA Connector.....	0090-3
Figure 3. Voltage Regulator Harness.....	0090-4
Figure 4. Voltage Regulator Harness.....	0090-5
Figure 5. Voltage Regulator Harness.....	0090-6
Figure 6. Voltage Regulator Harness.....	0090-7
Figure 7. Voltage Regulator Harness.....	0090-8
Figure 8. Voltage Regulator Harness.....	0090-9
Figure 9. Voltage Regulator Harness.....	0090-10
Figure 10. Voltage Regulator Harness.....	0090-11
Figure 11. Voltage Regulator Harness.....	0090-12
ALTERNATOR OVERCHARGING, BATTERY INDICATOR GAUGE IN RED POSITION.....	WP 0091
Figure 1. DCA Connector.....	0091-2
Figure 2. Alternator Electrical Wiring.....	0091-3
Figure 3. Alternator.....	0091-4
Figure 4. Alternator Wire 568.....	0091-5
Figure 5. Alternator Electrical Wiring.....	0091-6
HEADLAMP (ONE SIDE) INOPERATIVE.....	WP 0092
Figure 1. Headlamp Bulb.....	0092-2
Figure 2. Headlamp Connectors.....	0092-3
HEADLAMP (BOTH SIDE) INOPERATIVE.....	WP 0093
Figure 1. Beam Select Switch.....	0093-2
Figure 2. Beam Select Switch.....	0093-3
Figure 3. Main Lighting Switch.....	0093-4

TABLE OF CONTENTS - Continued

	Page No.
	<u>WP Sequence No.</u>
Figure 4. Main Lighting Switch Connector.....	0093-5
Figure 5. Main Lighting Switch Connector.....	0093-6
BLACKOUT DRIVE OR BLACKOUT MARKER LIGHT INOPERATIVE.....	WP 0094
Figure 1. Light Bulbs.....	0094-2
Figure 2. Light Socket.....	0094-2
Figure 3. Lamp Holder.....	0094-3
Figure 4. Blackout Light Assemblies.....	0094-4
Figure 5. Main Lighting Switch Connector.....	0094-5
Figure 6. Main Lighting Switch Connector.....	0094-6
Figure 7. Main Lighting Switch Connector.....	0094-7
STOPLIGHT INOPERATIVE (SERVICE OR BLACKOUT).....	WP 0095
Figure 1. Light Bulbs.....	0095-2
Figure 2. Light Socket.....	0095-2
Figure 3. Lamp Holder.....	0095-3
Figure 4. Stoplight Switch.....	0095-4
Figure 5. Main Lighting Switch Connector.....	0095-5
Figure 6. Main Lighting Switch Connector.....	0095-6
Figure 7. Main Lighting Switch Connector.....	0095-7
Figure 8. Stoplight Switch Test.....	0095-8
Figure 9. Main Lighting Switch Connector.....	0095-9
Figure 10. Main Lighting Switch Connector.....	0095-10
Figure 11. Main Lighting Switch Connector.....	0095-11
TAIL AND MARKER LIGHTS INOPERATIVE.....	WP 0096
Figure 1. Light Bulbs.....	0096-2
Figure 2. Light Socket.....	0096-2
Figure 3. Lamp Holder.....	0096-3
Figure 4. Rear Composite Light.....	0096-4

TABLE OF CONTENTS - Continued

	Page No.
	<u>WP Sequence No.</u>
Figure 5. Main Lighting Switch Connector.....	0096-5
Figure 6. Main Lighting Switch Connector.....	0096-6
Figure 7. Main Lighting Switch Connector.....	0096-6
INDIVIDUAL LIGHTS DO NOT LIGHT WITH DIRECTIONAL SIGNAL LEVER IN ANY POSITION.....	WP 0097
Figure 1. Light Bulbs.....	0097-2
Figure 2. Directional Signal Circuit Test.....	0097-3
Figure 3. Directional Signal Circuit Test.....	0097-4
Figure 4. Directional Signal Circuit Test.....	0097-5
NO LIGHTS OPERATE WITH DIRECTIONAL SIGNAL CONTROL LEVER IN ANY POSITION.....	WP 0098
Figure 1. Control Unit Harness Connector.....	0098-2
Figure 2. Main Lighting Switch Connector.....	0098-3
Figure 3. Main Lighting Switch Connector.....	0098-3
Figure 4. Main Lighting Switch Connector.....	0098-4
Figure 5. Flasher Wire Harness Test.....	0098-5
Figure 6. Flasher Wire Harness Test.....	0098-6
Figure 7. Flasher Wire Harness Test.....	0098-7
SYSTEM OPERATES INCORRECTLY IN ONE OR MORE POSITIONS OF DIRECTIONAL SIGNAL CONTROL LEVER.....	WP 0099
Figure 1. Directional Signal Control Neutral Position.....	0099-2
Figure 2. Directional Signal Control Right Turn Position.....	0099-3
Figure 3. Directional Signal Control Left Turn Position.....	0099-4
Figure 4. Directional Signal Control Hazzard Position.....	0099-5
PROTECTIVE CONTROL BOX ASSEMBLY TEST.....	WP 0100
Figure 1. Protective Control Box Connector.....	0100-2
Figure 2. Protective Control Box Connector.....	0100-3
Figure 3. Protective Control Box Connector.....	0100-4

TABLE OF CONTENTS - Continued

	Page No.
	<u>WP Sequence No.</u>
Figure 4. Protective Control Box Connector.....	0100-5
Figure 5. Protective Control Box Connector.....	0100-6
Figure 6. Protective Control Box Connector.....	0100-7
Figure 7. Protective Control Box Connector.....	0100-8
Figure 8. Protective Control Box Connector.....	0100-9
Figure 9. Protective Control Box Connector.....	0100-10
SPEEDOMETER OR TACHOMETER NOISY OR ERRATIC.....	WP 0101
Figure 1. Speedometer and Tachometer Flexible Shafts.....	0101-2
Figure 2. Speedometer and Tachometer.....	0101-3
AIR PRESSURE GAUGE INOPERATIVE.....	WP 0102
Figure 1. Air Pressure Gauge.....	0102-2
Figure 2. Air Pressure Gauge.....	0102-3
OIL PRESSURE GAUGE INOPERATIVE (OIL LEVEL IS CORRECT).....	WP 0103
Figure 1. Oil Pressure Sending Unit.....	0103-2
Figure 2. Oil Pressure Gauge Test.....	0103-4
Figure 3. Oil Pressure Gauge Voltage Test.....	0103-6
ALL GAUGES INOPERATIVE.....	WP 0104
Figure 1. Circuit Breaker.....	0104-2
Figure 2. Circuit Breaker Test.....	0104-3
Figure 3. Circuit 27 Wire Test.....	0104-4
TRANSMISSION TEMPERATURE GAUGE INOPERATIVE.....	WP 0105
Figure 1. Transmission Temperature Sending Unit.....	0105-2
Figure 2. Transmission Temperature Gauge Wire 324.....	0105-3
Figure 3. Transmission Temperature Gauge Wire 27.....	0105-4
TEMPERATURE GAUGE INOPERATIVE (COOLANT).....	WP 0106
Figure 1. Coolant Temperature Sending Unit.....	0106-2
Figure 2. Coolant Temperature Gauge Test.....	0106-4

TABLE OF CONTENTS - Continued

	<u>Page No.</u> <u>WP Sequence No.</u>
Figure 3. Coolant Temperature Gauge Voltage Test.....	0106-5
FUEL GAUGE INOPERATIVE.....	WP 0107
Figure 1. Fuel Level Sending Unit.....	0107-2
Figure 2. Fuel Level Gauge Test.....	0107-4
Figure 3. Fuel Selector Switch.....	0107-5
Figure 4. Fuel Gauge Test.....	0107-6
Figure 5. Fuel Gauge Test.....	0107-7
BATTERY/ALTERNATOR GAUGE INOPERATIVE.....	WP 0108
Figure 1. Battery-Alternator Gauge.....	0108-2
Figure 2. Battery-Alternator Gauge Test.....	0108-3
HORN INOPERATIVE.....	WP 0109
Figure 1. Horn Air Supply.....	0109-2
Figure 2. Horn Circuit Breaker.....	0109-3
Figure 3. Horn Circuit Breaker Test.....	0109-4
Figure 4. Horn Solenoid Test.....	0109-5
Figure 5. Horn Solenoid Test.....	0109-6
Figure 6. Horn Switch Test.....	0109-8
LOW AIR PRESSURE WARNING BUZZER WILL NOT SHUT OFF (AIR PRESSURE GAUGES AT NORMAL SYSTEM PRESSURE).....	WP 0110
Figure 1. Pressure Switch.....	0110-2
Figure 2. Pressure Switch.....	0110-4
Figure 3. Pressure Switch Wire 57.....	0110-6
Figure 4. Pressure Switch Wire 578A.....	0110-8
Figure 5. Failsafe Warning Control Module.....	0110-10
LOW AIR PRESSURE WARNING BUZZER WILL NOT SHUT OFF AND PARKING BRAKE WARNING LIGHT FLASHES WITH HAND/PARKING BRAKE IN ANY POSITION (AIR PRESSURE NORMAL).....	WP 0111
Figure 1. Pressure Switch.....	0111-2

TABLE OF CONTENTS - Continued

	Page No.
	<u>WP Sequence No.</u>
Figure 2. Pressure Switch.....	0111-3
SPRING BRAKE WARNING LIGHT INOPERATIVE WITH SPRING BRAKE OVERRIDE ENGAGED.....	WP 0112
Figure 1. Spring Brake Override Light.....	0112-2
Figure 2. Spring Brake Pressure Switch Wire 37.....	0112-3
Figure 3. Spring Brake Override Warning Circuit Breaker Wire 10.....	0112-4
Figure 4. Spring Brake Override Warning Circuit Breaker Wire 37.....	0112-5
ONE OR MORE TRAILER LIGHTS INOPERATIVE.....	WP 0113
Figure 1. Lighting System.....	0113-2
Figure 2. Trailer Receptacle.....	0113-3
Figure 3. Trailer Receptacle.....	0113-4
Figure 4. Trailer Receptacle.....	0113-5
Figure 5. Trailer Lighting System Cable.....	0113-6
Figure 6. Trailer.....	0113-7
HEATER WILL NOT OPERATE WITH SWITCH IN LOW POSITION (HIGH POSITION OPERATION NORMAL).....	WP 0114
Figure 1. Heater Switch Wiring.....	0114-2
Figure 2. Circuit Breaker Wire 569A.....	0114-3
Figure 3. Circuit Breaker Wire 569A.....	0114-4
Figure 4. Battery Switch Wire 569A.....	0114-5
HEATER WILL NOT OPERATE WITH SWITCH IN HIGH POSITION (LOW POSITION OPERATION NORMAL).....	WP 0115
Figure 1. Heater Switch Wiring.....	0115-2
Figure 2. Circuit Breaker Wire 27.....	0115-3
Figure 3. Circuit Breaker Wire 5A.....	0115-4
HEATER WILL NOT OPERATE IN LOW OR HIGH POSITION.....	WP 0116
Figure 1. Heater Blower Motor Wiring.....	0116-2
Figure 2. Heater Switch Wiring.....	0116-4

TABLE OF CONTENTS - Continued

	Page No.
	<u>WP Sequence No.</u>
NO CAB HEAT (COOLANT TEMPERATURE GAUGE READS NORMAL).....	WP 0117
Figure 1. Engine Coolant Shutoff Valve.....	0117-2
Figure 2. Coolant Level.....	0117-3
PARKING BRAKE DOES NOT HOLD VEHICLE ON GRADE.....	WP 0118
Figure 1. Brake Lever.....	0118-2
Figure 2. Parking Brake Cable Assembly.....	0118-3
Figure 3. Parking Brake Assembly.....	0118-4
Figure 4. Parking Brake Actuating Mechanism.....	0118-5
PARKING BRAKE DRAGS, AS INDICATED BY SMOKING OR BURNING SMELL.....	WP 0119
Figure 1. Brake Lever.....	0119-2
Figure 2. Brake Lever.....	0119-3
Figure 3. Parking Brake Cable Assembly.....	0119-4
Figure 4. Parking Brake Actuating Mechanism.....	0119-5
INSUFFICIENT BRAKES (VEHICLE STOPPING DISTANCE TOO LONG, NO APPARENT AIR SYSTEM FAILURE WITH GAUGES AT NORMAL OPERATING PRESSURE, WARNING BUZZER NOT SOUNDING).....	WP 0120
Figure 1. Service Brake Chamber Vent Line.....	0120-2
Figure 2. Front Service Brake Chamber.....	0120-4
Figure 3. Front Service Brake Chamber.....	0120-6
Figure 4. Rear Service Brake Chamber.....	0120-8
Figure 5. Rear Service Brake Chamber.....	0120-10
Figure 6. Rear Service Brake Chamber.....	0120-12
Figure 7. Rear Service Brake Chamber.....	0120-14
Figure 8. Rear Service Brake Chamber.....	0120-16
Figure 9. Rear Service Brake Chamber.....	0120-18
Figure 10. Rear Service And Spring Brake Chamber.....	0120-20
Figure 11. Rear Service And Spring Brake Chamber.....	0120-22
Figure 12. Rear Service And Spring Brake Chamber.....	0120-24

TABLE OF CONTENTS - Continued

	Page No.
	<u>WP Sequence No.</u>
Figure 13. Rear Service And Spring Brake Chamber.....	0120-26
Figure 14. Rear Service And Spring Brake Chamber.....	0120-28
Figure 15. Rear Service And Spring Brake Chamber.....	0120-30
Figure 16. Limiting Valve.....	0120-32
Figure 17. Limiting Valve.....	0120-34
Figure 18. Limiting Valve.....	0120-36
Figure 19. Limiting Valve.....	0120-37
Figure 20. Double Check Valve #1.....	0120-38
Figure 21. Service Brake Pedal Valve.....	0120-40
Figure 22. Primary Relay Valve Delivery Port.....	0120-42
Figure 23. Primary Relay Valve Delivery Port.....	0120-44
Figure 24. Primary Relay Valve Supply Port.....	0120-46
Figure 25. Secondary Relay Valve Delivery Port.....	0120-48
Figure 26. Secondary Relay Valve Delivery Port.....	0120-50
Figure 27. Secondary Relay Valve Supply Port.....	0120-52
Figure 28. Brake Assembly.....	0120-54
VEHICLE PULLS RIGHT OR LEFT WHEN APPLYING BRAKES.....	WP 0121
Figure 1. Front Service Brake Chamber.....	0121-2
Figure 2. Brake Shoe Assembly.....	0121-4
Figure 3. Brake Drum.....	0121-5
Figure 4. Left and Right Brake Assemblies.....	0121-6
Figure 5. Service Brake Adjustment.....	0121-7
VEHICLE REAR BRAKES GRAB OR DRAG.....	WP 0122
Figure 1. Brake Shoe Assembly.....	0122-2
Figure 2. Brake Drum.....	0122-3
Figure 3. Left and Right Brake Assemblies.....	0122-4
Figure 4. Service Brake Adjustment.....	0122-5

TABLE OF CONTENTS - Continued

	Page No.
	<u>WP Sequence No.</u>
Figure 5. Rear Service Brake Chamber.....	0122-6
Figure 6. Rear Service and Spring Brake Chamber.....	0122-6
VEHICLE VIBRATES, CHATTERS, OR BOUNCES WHEN BRAKES ARE APPLIED.....	WP 0123
Figure 1. Rear Service Brake Chamber.....	0123-2
Figure 2. Rear Service and Spring Brake Chamber.....	0123-3
BRAKES SQUEAL.....	WP 0124
Figure 1. Brakeshoes.....	0124-2
Figure 2. Brakeshoes.....	0124-3
WARNING BUZZER SOUNDS WHEN BRAKES ARE APPLIED (PRIMARY & SECONDARY GAUGE PRESSURE DROPS BELOW 55-65 PSI [379-448 KPA]).....	WP 0125
NO AIR PRESSURE (WARNING BUZZER SOUNDING, AIR PRESSURE NOT BUILDING TO NORMAL OPERATING RANGE AS INDICATED BY GAUGES).....	WP 0126
Figure 1. Air Supply System.....	0126-2
Figure 2. Air Compressor Governor Signal Line.....	0126-4
Figure 3. Air Compressor Outlet Line.....	0126-5
Figure 4. Air Compressor Outlet Line.....	0126-6
Figure 5. Wet Supply Tank.....	0126-8
Figure 6. Air Pressure Gauges.....	0126-9
Figure 7. Air Governor.....	0126-10
AIR PRESSURE DOES NOT BUILD TO NORMAL OPERATING PRESSURE (ABOVE 80 PSI [552 KPA]) ACCORDING TO GAUGES.....	WP 0127
Figure 1. Air Supply System.....	0127-2
Figure 2. Air Governor.....	0127-3
AIR PRESSURE BUILDS SLOWLY (TAKES EXCESSIVE AMOUNT OF TIME TO BUILD TO 100 PSI (690KPA)).....	WP 0128
Figure 1. Air Supply System.....	0128-2
Figure 2. Air Governor.....	0128-3
AIR PRESSURE EXCEEDS MAXIMUM (GAUGES SHOW OVER 130 PSI [896 KPA]), SAFETY VALVE OPENS TO RELEASE PRESSURE.....	WP 0129

TABLE OF CONTENTS - Continued

	Page No.
	<u>WP Sequence No.</u>
Figure 1. Auxiliary Air Power System.....	0129-2
Figure 2. Air Governor Signal Line.....	0129-3
Figure 3. Air Governor Signal Line.....	0129-4
PRIMARY PRESSURE GAUGE READS NO PRESSURE, LOW PRESSURE, OR BUILDS TO NORMAL OPERATING PRESSURE SLOWLY. SECONDARY PRESSURE GAUGE READS NORMAL (ENGINE IDLING, BRAKE PEDAL NOT APPLIED).....	WP 0130
Figure 1. Air Supply System.....	0130-2
Figure 2. Primary Air Pressure Gauge.....	0130-3
Figure 3. Brake Pedal.....	0130-4
Figure 4. Primary Air Reservoir Drain Line.....	0130-5
Figure 5. Primary Air System Supply Line.....	0130-6
Figure 6. One-Way Check Valve.....	0130-7
SECONDARY PRESSURE GAUGE READS NO PRESSURE, LOW PRESSURE, OR BUILDS TO NORMAL OPERATING PRESSURE SLOWLY. PRIMARY PRESSURE GAUGE READS NORMAL (ENGINE IDLING, BRAKE PEDAL NOT APPLIED).....	WP 0131
Figure 1. Air Supply System.....	0131-2
Figure 2. Secondary Air Pressure Gauge.....	0131-3
Figure 3. Brake Pedal.....	0131-4
Figure 4. Secondary Air Reservoir Drain Line.....	0131-6
Figure 5. Secondary Air System Supply Line.....	0131-8
Figure 6. One-Way Check Valve.....	0131-9
PRIMARY AIR SYSTEM FAILS TO MAINTAIN PRESSURE (NO MAJOR LEAKS, AIR CAN BE HEARD ESCAPING INTO AIR INTAKE STACK, PARKING BRAKE APPLIED).....	WP 0132
Figure 1. Service Brake Chamber Vent Line.....	0132-2
SECONDARY AIR SYSTEM FAILS TO MAINTAIN PRESSURE (NO MAJOR LEAKS, AIR CAN BE HEARD ESCAPING INTO AIR INTAKE STACK, PARKING BRAKE APPLIED).....	WP 0133
Figure 1. Secondary Relay Valve Delivery Port.....	0133-2
Figure 2. Secondary Relay Valve Delivery Port.....	0133-4
Figure 3. Service Brake Pedal Valve.....	0133-6

TABLE OF CONTENTS - Continued

	Page No.
	<u>WP Sequence No.</u>
WARNING BUZZER FAILS TO SOUND OR FAILS TO SHUT OFF ON LOW PRESSURE (BELOW 55-65 PSI [379-448 KPA]), AIR PRESSURE SYSTEM OPERATING NORMALLY.....	WP 0134
SPRING BRAKES DO NOT RELEASE (VEHICLE BRAKES GRAB OR DRAG).....	WP 0135
Figure 1. Spring Brake Release Control.....	0135-2
Figure 2. Parking Brake Control Lever.....	0135-3
Figure 3. Parking Brake Control Lever.....	0135-4
Figure 4. Parking Brake Valve.....	0135-5
Figure 5. Air Intake Stack.....	0135-6
Figure 6. Parking Brake Valve.....	0135-7
Figure 7. Parking Brake Quick Release Valve Assembly.....	0135-8
SPRING BRAKES DO NOT SET (GAUGES AT NORMAL OPERATING PRESSURES, AIR EXHAUSTING NOT HEARD WHEN PARKING BRAKE APPLIED).....	WP 0136
Figure 1. Spring Brake Control.....	0136-2
Figure 2. Spring Brake Assembly.....	0136-3
Figure 3. Quick Release Valve.....	0136-4
Figure 4. Parking Brake Valve.....	0136-5
ALL AIR-OPERATED ACCESSORIES DO NOT OPERATE (HORN, WINDSHIELD WIPERS, WINDSHIELD WASHERS, TRANSFER CASE CONTROLS), GAUGES AT NORMAL OPERATING PRESSURE.....	WP 0137
Figure 1. Air Pressure Gauges.....	0137-2
COOLING FAN DOES NOT OPERATE, ENGINE TEMPERATURE ABOVE 195°F (91°C) AS INDICATED BY TEMPERATURE GAUGE.....	WP 0138
Figure 1. Secondary Air Pressure Gauge.....	0138-2
Figure 2. Fan Clutch Actuator.....	0138-3
COOLING FAN DOES NOT STOP RUNNING, ENGINE TEMPERATURE BELOW NORMAL OPERATING RANGE (OVERRIDE BOLT NOT INSTALLED).....	WP 0139
Figure 1. Fan Clutch Actuator.....	0139-2
FRONT WHEEL DRIVE DOES NOT ENGAGE (FRONT WHEEL DRIVE LOCK-IN SWITCH ENGAGED AND TRANSFER CASE SHIFT LEVER IN HIGH POSITION).....	WP 0140
Figure 1. Transfer Case Shift Lever.....	0140-2

TABLE OF CONTENTS - Continued

	Page No.
	<u>WP Sequence No.</u>
Figure 2. Transfer Case Shift Lever and Drive Lock In Switch.....	0140-3
Figure 3. Transfer Case Shift Lever.....	0140-4
Figure 4. Air Line Between Actuator Valve and Transfer Case.....	0140-5
Figure 5. Air Supply Line to Actuator Valve.....	0140-6
Figure 6. Air Supply Line to Actuator Valve.....	0140-7
Figure 7. Front Wheel Drive Lock-in Switch.....	0140-8
Figure 8. Actuator Valve.....	0140-9
Figure 9. Actuator Valve.....	0140-10
HORN DOES NOT WORK (GAUGES AT NORMAL OPERATING PRESSURE, WARNING BUZZER NOT SOUNDING).....	WP 0141
Figure 1. Air Horn.....	0141-2
Chapter 3 - CTIS TROUBLESHOOTING PROCEDURES	
CENTRAL TIRE INFLATION SYSTEM (CTIS) TROUBLESHOOTING.....	WP 0142
CTIS TROUBLESHOOTING INDEX.....	WP 0143
TWO PRESSURE MODES INDICATED WITH STEADY MODE LIGHTS.....	WP 0144
Figure 1. Air Lines.....	0144-2
Figure 2. Air Lines.....	0144-3
Figure 3. Air Lines.....	0144-4
Figure 4. Air Dryer And Water Seperator.....	0144-5
Figure 5. Quick Release Valves And Pneumatic Controller.....	0144-6
Figure 6. Quick Release Valves And Pneumatic Controller.....	0144-7
Figure 7. Quick Release Valves And Pneumatic Controller.....	0144-8
Figure 8. Quick Release Valves And Wheel Valves.....	0144-9
Figure 9. Quick Release Valves And Wheel Valves.....	0144-10
Figure 10. Quick Release Valves And Wheel Valves.....	0144-11
Figure 11. Hub Air Seals.....	0144-12
Figure 12. Pneumatic Controller.....	0144-13
Figure 13. Quick Release Valves.....	0144-14

TABLE OF CONTENTS - Continued

	Page No.
	<u>WP Sequence No.</u>
Figure 14. Relief Valve.....	0144-15
Figure 15. CTIS Wiring Harness.....	0144-16
Figure 16. Pressure Transducer.....	0144-17
Figure 17. CTIS Wiring Harness.....	0144-18
Figure 18. CTIS Wiring Harness.....	0144-20
Figure 19. Pressure Transducer.....	0144-22
Figure 20. Pneumatic Controller.....	0144-23
FOUR PRESSURE MODE LIGHTS FLASHING.....	WP 0145
Figure 1. Wheel Valve.....	0145-2
Figure 2. Wheel Valve.....	0145-3
Figure 3. Wheel Valve.....	0145-4
Figure 4. Wheel Valve.....	0145-6
Figure 5. Quick Release Valves And Pneumatic Controller.....	0145-7
Figure 6. Quick Release Valves And Pneumatic Controller.....	0145-8
Figure 7. Quick Release Valves And Pneumatic Controller.....	0145-9
Figure 8. Hub Air Seals.....	0145-10
Figure 9. Pneumatic Controller.....	0145-11
FIVE INDICATOR LIGHTS FLASHING.....	WP 0146
Figure 1. Quick Release Valves And Pneumatic Controller.....	0146-2
Figure 2. Quick Release Valves And Pneumatic Controller.....	0146-3
Figure 3. Quick Release Valves and Pneumatic Controller.....	0146-4
Figure 4. Quick Release Valves And Wheel Valves.....	0146-5
Figure 5. Quick Release Valves and Wheel Valves.....	0146-6
Figure 6. Quick Release Valves and Wheel Valves.....	0146-7
Figure 7. Pneumatic Controller.....	0146-8
Figure 8. Wet Tank.....	0146-9
Figure 9. CTIS Wiring Harness.....	0146-10

TABLE OF CONTENTS - Continued

	Page No.
	<u>WP Sequence No.</u>
Figure 10. Pressure Transducer.....	0146-11
Figure 11. Pressure Transducer.....	0146-12
Figure 12. Electronic Control Unit	0146-13
Figure 13. CTIS Wiring Harness.....	0146-14
Figure 14. CTIS Wiring Harness.....	0146-16
Figure 15. Pressure Transducer.....	0146-18
Figure 16. Pneumatic Controller.....	0146-19
SYSTEM REPEATEDLY RESUMES CYCLING 30 SECONDS AFTER MODE LIGHT STOPS	
FLASHING.....	WP 0147
Figure 1. Wheel Valve.....	0147-2
Figure 2. Wheel Valve.....	0147-3
Figure 3. Wheel Valve.....	0147-4
SYSTEM FAILS TO DEFLATE, PARTIALLY DEFLATES, OR TIRE PRESSURES ARE	
IMBALANCED.....	WP 0148
Figure 1. Relief Valve.....	0148-2
Figure 2. Quick Release Valves.....	0148-3
Figure 3. Pneumatic Controller.....	0148-4
Figure 4. Air Lines.....	0148-5
Figure 5. Air Lines.....	0148-6
Figure 6. Air Lines.....	0148-7
Figure 7. Hub Air Seals.....	0148-8
Figure 8. Relief Valve.....	0148-9
Figure 9. Tire.....	0148-10
Figure 10. Wheel Valve Filter.....	0148-12
CONTROL PANEL LIGHTS WORK, SYSTEM FAILS TO INFLATE OR DEFLATE.....	
	WP 0149
Figure 1. Air Lines.....	0149-2
Figure 2. Air Lines.....	0149-3
Figure 3. Air Lines.....	0149-4

TABLE OF CONTENTS - Continued

	Page No.
	<u>WP Sequence No.</u>
Figure 4. CTIS Wiring Harness.....	0149-6
Figure 5. Pneumatic Controller.....	0149-7
Figure 6. Wet Tank.....	0149-8
Figure 7. CTIS Wiring Harness.....	0149-9
Figure 8. Pressure Switch.....	0149-10
Figure 9. Pressure Switch.....	0149-11
LOSS OF AMBER WARNING LIGHT AND/OR OVERSPEED LIGHT.....	WP 0150
Figure 1. CTIS Amber Warning Light.....	0150-2
Figure 2. CTIS Electronic Control Unit.....	0150-3
Figure 3. CTIS Wiring Harness.....	0150-4
Figure 4. Speed Signal Generator and ECU.....	0150-5
Figure 5. Speed Signal Generator.....	0150-6
SOLID OVERSPEED WARNING LIGHT.....	WP 0151
Figure 1. Speed Signal Generator and ECU.....	0151-2
Figure 2. Speed Signal Generator.....	0151-3
SYSTEM OVER-INFLATES TIRES.....	WP 0152
Figure 1. Tire.....	0152-2
Figure 2. CTIS Wiring Harness.....	0152-4
Figure 3. CTIS Wiring Harness.....	0152-6
Figure 4. Pressure Transducer.....	0152-8
SLOW AIR RECOVERY OR OCCASIONAL LOW AIR WARNING DURING BRAKING.....	WP 0153
Figure 1. Pressure Switch.....	0153-2
Figure 2. CTIS Wiring Harness.....	0153-4
Figure 3. Pressure Switch.....	0153-6
Figure 4. Pressure Switch.....	0153-7
Figure 5. Pressure Switch.....	0153-8

Index

Volume 2

TABLE OF CONTENTS - Continued

	Page No.
	<u>WP Sequence No.</u>
Chapter 4 - ABS TROUBLESHOOTING PROCEDURES	
ANTILOCK BRAKE SYSTEM (ABS) ELECTRONIC DIAGNOSTIC TROUBLESHOOTING.....	WP 0154
Figure 1. ABS Wiring Harness ECU Connector.....	0154-3
Table 1. Diagnostic Fault Codes.....	0154-4
ABS TROUBLESHOOTING INDEX.....	WP 0155
TROUBLESHOOTING ABS WITHOUT DIAGNOSTIC TOOLS.....	WP 0156
Figure 1. Wheel Speed Sensor Leads.....	0156-2
Figure 2. ABS Solenoid Valve Connectors.....	0156-3
Figure 3. ABS Wiring Harness 28-pin ECU Connector.....	0156-4
Figure 4. ABS Power Supply Connection.....	0156-6
Figure 5. ABS Power Supply Connection.....	0156-8
Figure 6. Battery Test Points.....	0156-10
Figure 7. ABS Power Supply Connection.....	0156-11
Figure 8. ABS Power Supply Connection.....	0156-12
ABS - CODE EO - E9, EA - EF (ECU FAULT).....	WP 0157
Figure 1. ABS ECU.....	0157-2
ABS - CODE SOL 80, ECU 93, OR ECU 99 (ECU FAULT).....	WP 0158
Figure 1. ABS ECU.....	0158-2
ABS - CLEAR HISTORICAL CODES WITH THE HALDEX INFO CENTER (SCAN TOOL).....	WP 0159
Figure 1. Info Centre Fault Code "OK 07" Display.....	0159-2
Figure 2. Info Centre "BUSY" Display.....	0159-3
Figure 3. Info Centre Fault Code Display.....	0159-4
Figure 4. Info Centre "CLR CA" Display.....	0159-4
Figure 5. Info Centre Fault Code "OK 07" Display.....	0159-5
WHEEL SPEED SENSOR OUTPUT TEST.....	WP 0160
Figure 1. Info Centre Fault Code "OK 07" Display.....	0160-2
Figure 2. Info Centre "WHL" Display.....	0160-3

TABLE OF CONTENTS - Continued

	Page No.
	<u>WP Sequence No.</u>
Figure 3. Info Centre "S2A" Display.....	0160-3
Figure 4. Wheel Speed Sensor.....	0160-4
Figure 5. Info Centre "S2B" Display.....	0160-5
Figure 6. Wheel Speed Sensor.....	0160-6
ABS - START - RETRIEVING FAULT CODES WITH THE HALDEX INFO CENTER (SCAN TOOL).....	WP 0161
Figure 1. Info Centre Fault Code "OK 07" Display.....	0161-2
Figure 2. Info Centre "BUSY" Display.....	0161-3
Figure 3. Info Centre Fault Code Display.....	0161-4
Figure 4. Info Centre "CLR CA" Display.....	0161-4
Figure 5. Info Centre Fault Code "OK 07" Display.....	0161-6
ABS - CODE S2A 03 (LEFT SIDE - BLUE CHANNEL).....	WP 0162
Figure 1. Wheel Speed Sensor Connector.....	0162-2
Figure 2. ABS Wiring Harness 28-pin ECU Connector.....	0162-4
Figure 3. ABS Wiring Harness 28-pin ECU Connector.....	0162-6
ABS - CODE S2B 04 (RIGHT SIDE - YELLOW CHANNEL).....	WP 0163
Figure 1. Wheel Speed Sensor Connector.....	0163-2
Figure 2. ABS Wiring Harness 28-pin ECU Connector.....	0163-4
Figure 3. ABS Wiring Harness 28-pin ECU Connector.....	0163-6
ABS - CODE S2A 13 (LEFT SIDE - BLUE CHANNEL).....	WP 0164
Figure 1. Wheel Speed Sensor Connector.....	0164-2
ABS - CODE S2B 14 (RIGHT SIDE - YELLOW CHANNEL).....	WP 0165
Figure 1. Wheel Speed Sensor Connector.....	0165-2
ABS - CODE S2A 23 (LEFT SIDE - BLUE CHANNEL).....	WP 0166
Figure 1. Wheel Bearing.....	0166-2
Figure 2. ABS Exciter Ring.....	0166-3
Figure 3. ABS Wheel Speed Sensor.....	0166-4
ABS - CODE S2A 24 (RIGHT SIDE - YELLOW CHANNEL).....	WP 0167

TABLE OF CONTENTS - Continued

	Page No.
	<u>WP Sequence No.</u>
Figure 1. Wheel Bearing.....	0167-2
Figure 2. ABS Exciter Ring.....	0167-3
Figure 3. ABS Wheel Speed Sensor.....	0167-4
ABS - CODE SLW 42 (LEFT SIDE - BLUE CHANNEL).....	WP 0168
Figure 1. Front Relay Valve.....	0168-2
Figure 2. Front Modulator Valve.....	0168-3
ABS - CODE SLW 43 (RIGHT SIDE - YELLOW CHANNEL).....	WP 0169
Figure 1. Rear Relay Valve.....	0169-2
Figure 2. Rear Modulator Valve.....	0169-3
ABS - CODE BUHd 62 (LEFT SIDE - BLUE CHANNEL).....	WP 0170
Figure 1. Front Relay Valve Solenoid Connector.....	0170-2
Figure 2. Front Relay Valve Solenoid Connector.....	0170-3
Figure 3. ABS Wiring Harness 28-pin ECU Connector.....	0170-4
ABS - CODE YEHd 63 (RIGHT SIDE - YELLOW CHANNEL).....	WP 0171
Figure 1. Rear Relay Valve Solenoid Connector.....	0171-2
Figure 2. Rear Relay Valve Solenoid Connector.....	0171-3
Figure 3. ABS Wiring Harness 28-pin ECU Connector.....	0171-4
ABS - CODE BUDU 68 (LEFT SIDE - BLUE CHANNEL).....	WP 0172
Figure 1. Front Relay Valve Solenoid Connector.....	0172-2
Figure 2. Front Relay Valve Solenoid Connector.....	0172-3
Figure 3. ABS Wiring Harness 28-pin ECU Connector.....	0172-4
ABS - CODE YEDU 69 (RIGHT SIDE - YELLOW CHANNEL).....	WP 0173
Figure 1. Rear Relay Valve Solenoid Connector.....	0173-2
Figure 2. Rear Relay Valve Solenoid Connector.....	0173-3
Figure 3. ABS Wiring Harness 28-pin ECU Connector.....	0173-4
ABS - CODE BUHd 72 (LEFT SIDE - BLUE CHANNEL).....	WP 0174
Figure 1. Front Relay Valve Solenoid Connector.....	0174-2

TABLE OF CONTENTS - Continued

	Page No.
	<u>WP Sequence No.</u>
Figure 2. ABS Wiring Harness 28-pin ECU Connector.....	0174-4
ABS - CODE YEHd 73 (RIGHT SIDE - YELLOW CHANNEL).....	WP 0175
Figure 1. Rear Relay Valve Solenoid Connector.....	0175-2
Figure 2. ABS Wiring Harness 28-pin ECU Connector.....	0175-4
ABS - CODE BUDU 78 (LEFT SIDE - BLUE CHANNEL).....	WP 0176
Figure 1. Front Relay Valve Solenoid Connector.....	0176-2
Figure 2. ABS Wiring Harness 28-pin ECU Connector.....	0176-4
ABS - CODE YEDU 79 (RIGHT SIDE - YELLOW CHANNEL).....	WP 0177
Figure 1. Rear Relay Valve Solenoid Connector.....	0177-2
Figure 2. ABS Wiring Harness 28-pin ECU Connector.....	0177-4
ABS - CODE BUHd 82 (LEFT SIDE - BLUE CHANNEL).....	WP 0178
Figure 1. Front Relay Valve Solenoid Connector.....	0178-2
Figure 2. ABS Wiring Harness 28-pin ECU Connector.....	0178-4
ABS - CODE YEHd 83 (RIGHT SIDE - YELLOW CHANNEL).....	WP 0179
Figure 1. Rear Relay Valve Solenoid Connector.....	0179-2
Figure 2. ABS Wiring Harness 28-pin ECU Connector.....	0179-4
ABS - CODE BUDU 88 (LEFT SIDE - BLUE CHANNEL).....	WP 0180
Figure 1. Front Relay Valve Solenoid Connector.....	0180-2
Figure 2. ABS Wiring Harness 28-pin ECU Connector.....	0180-4
ABS - CODE YEDU 89 (RIGHT SIDE - YELLOW CHANNEL).....	WP 0181
Figure 1. Rear Relay Valve Solenoid Connector.....	0181-2
Figure 2. ABS Wiring Harness 28-pin ECU Connector.....	0181-4
ABS - CODE B+LO 90 (ABS VOLTAGE BELOW 21.0 VOLTS).....	WP 0182
Figure 1. Battery Test Points.....	0182-2
ABS - CODE ISO1 91 (ABS VOLTAGE BELOW 8.0 VOLTS).....	WP 0183
ABS - CODE B+HI 92 (ABS VOLTAGE ABOVE 32.0 VOLTS).....	WP 0184
Figure 1. Battery Test Points.....	0184-2

TABLE OF CONTENTS - Continued

	Page No.
	<u>WP Sequence No.</u>
ABS - NO DATA (BLANK SCREEN ON HALDEX INFO-CENTER).....	WP 0185
Figure 1. ABS Wiring Harness 28-pin ECU Connector.....	0185-2
Chapter 5 - STE/ICE TROUBLESHOOTING PROCEDURES	
STE/ICE TROUBLESHOOTING.....	WP 0186
Table 1. Go-Chain Test Index, Combined Mode Chain.....	0186-2
Table 2. No-Go-Chain Test Index, Combined Mode Chain.....	0186-3
STE/ICE TROUBLESHOOTING INDEX.....	WP 0187
G01: VTM CONNECTION AND CHECKOUT (PART 1).....	WP 0188
Figure 1. STE/ICE Setup.....	0188-2
Figure 2. VTM Display.....	0188-3
Figure 3. VTM Display.....	0188-4
Figure 4. VTM Display.....	0188-5
Table 1. Confidence Test.....	0188-5
Figure 5. VTM Display.....	0188-6
Figure 6. Test 99.....	0188-7
Figure 7. PASS Prompt Message.....	0188-7
Figure 8. PASS Prompt Message.....	0188-8
Figure 9. VTM Display.....	0188-9
Table 2. Vehicle Identification Number.....	0188-9
Table 3. Offset Test.....	0188-10
Table 4. Fuel Pressure Test.....	0188-10
Figure 10. Calibration Prompt Message.....	0188-10
G02: FIRST PEAK TEST- STARTER CURRENT.....	WP 0189
Figure 1. CAL Prompt Message.....	0189-2
Figure 2. GO Prompting Message.....	0189-3
G03: ENGINE START- LUBRICATION CHECK.....	WP 0190
G04: CHARGING CIRCUIT AND BATTERY VOLTAGE TEST.....	WP 0191

TABLE OF CONTENTS - Continued

	Page No.
	<u>WP Sequence No.</u>
Table 1. Battery Voltage Test.....	0191-1
G05: ENGINE WARMUP/COOLANT CHECK/OIL PRESSURE TEST.....	WP 0192
Table 1. Engine RPM Test.....	0192-2
Table 2. Engine Oil Pressure Specification.....	0192-2
G06: GOVERNOR CHECK/POWER TEST.....	WP 0193
Table 1. Maximum Governor Speed.....	0193-1
Table 2. Power Test.....	0193-2
Figure 1. CIP Prompting Message.....	0193-2
Table 3. Power Minimum Test Limits.....	0193-3
G07: IDLE SPEED/GOVERNOR CHECK.....	WP 0194
Table 1. Engine RPM Test.....	0194-1
G08: COMPRESSION UNBALANCE TEST.....	WP 0195
Table 1. Engine RPM Test.....	0195-2
Figure 1. GO Prompting Message.....	0195-2
Figure 2. CAL Prompting Message.....	0195-2
DC VOLTAGE TEST.....	WP 0196
Figure 1. STE/ICE Test.....	0196-2
Table 1. Voltage Test.....	0196-2
Figure 2. CAL Prompt Message.....	0196-3
NG05: LOW PRESSURE CHECK.....	WP 0197
Figure 1. STE/ICE Setup.....	0197-2
Figure 2. CAL Prompt Message.....	0197-2
Figure 3. Pass Prompt Message.....	0197-3
Table 1. Oil Pressure Limits.....	0197-3
Figure 4. Pass Prompt Message.....	0197-4
Table 2. Oil Pressure Limits.....	0197-4
NG20: NO CRANK- NO START.....	WP 0198

TABLE OF CONTENTS - Continued

	Page No.
	<u>WP Sequence No.</u>
NG30: ENGINE CRANK - NO START.....	WP 0199
Table 1. Engine RPM Test.....	0199-1
Figure 1. CAL Prompt Message.....	0199-2
Table 2. Pressure Test.....	0199-3
NG31: GAUGE TEST.....	WP 0200
Table 1. Voltage Test.....	0200-2
Figure 1. CAL Prompt Message.....	0200-2
NG50: CHARGING CIRCUIT TESTS.....	WP 0201
Table 1. Voltage Test.....	0201-2
NG80: STARTER CIRCUIT TESTS.....	WP 0202
Table 1. Starter Circuit Resistance Test.....	0202-2
Figure 1. CAL Message.....	0202-2
Figure 2. Prompt Message.....	0202-3
Table 2. Starter Circuit Resistance.....	0202-4
Table 3. Starter Circuit Tests.....	0202-5
Table 4. Starter Motor Voltage Test.....	0202-6
Table 5. Starter Voltage.....	0202-6
Table 6. Starter Negative Cable Drop Tests.....	0202-7
Table 7. Starter Solenoid Voltage Test.....	0202-8
Table 8. Starter Voltage.....	0202-8
Table 9. Battery Voltage Test.....	0202-9
NG81: BATTERY TESTS.....	WP 0203
Figure 1. CAL Prompting Message.....	0203-1
Figure 2. Battery Tests.....	0203-2
Figure 3. CAL Prompting Message.....	0203-3
Figure 4. GO Prompting Message.....	0203-4
Table 1. Battery Resistance Change Test.....	0203-4

TABLE OF CONTENTS - Continued

	Page No.
	<u>WP Sequence No.</u>
Figure 5. OFF Prompting Message.....	0203-4
Table 2. Maximum Resistance Change.....	0203-5
Table 3. Battery Resistance Test.....	0203-6
Figure 6. Prompt Message.....	0203-6
Table 4. Maximum Resistance.....	0203-6
NG90: GOVERNOR/POWER TEST FAULT ISOLATION.....	WP 0204
Figure 1. CAL Prompting Message.....	0204-3
Table 1. Pressure Test.....	0204-4
Table 2. Minimum Fuel Pressure.....	0204-4
Table 3. Engine RPM Test.....	0204-5
Figure 2. Prompt Message.....	0204-5
Table 4. Compression Unbalance Test Limits.....	0204-6
NG130: ENGINE TIGHTNESS TEST.....	WP 0205
Chapter 6 - PREVENTIVE MAINTENANCE INSTRUCTIONS	
PREVENTIVE MAINTENANCE CHECKS AND SERVICES (PMCS) INTRODUCTION.....	WP 0206
PREVENTIVE MAINTENANCE CHECKS AND SERVICES FOR MODELS M939/A1/A2 (SEMIANNUAL).....	WP 0207
Table 1. Field Preventive Maintenance Checks and Services.....	0207-2
Figure 1. Front Winch.....	0207-11
Figure 2. Front Winch.....	0207-13
Figure 3. Wheel Assembly.....	0207-17
Figure 4. Steering System.....	0207-21
Figure 5. Power Steering Pump.....	0207-23
Figure 6. Springs and Shackles.....	0207-24
Figure 7. Front Shackle.....	0207-24
Figure 8. Differential.....	0207-26
Figure 9. Differential.....	0207-39
Table 2. PMCS Mandatory Replacement Parts List.....	0207-42

TABLE OF CONTENTS - Continued

	Page No.
	<u>WP Sequence No.</u>
PREVENTIVE MAINTENANCE CHECKS AND SERVICES FOR MODELS M939/A1/A2 (ANNUAL).....	WP 0208
Table 1. Field Preventive Maintenance Checks and Services.....	0208-2
Figure 1. Engine Mounts.....	0208-3
Figure 2. Air System.....	0208-5
Figure 3. Air System.....	0208-6
Table 2. PMCS Mandatory Replacement Parts List.....	0208-11
PREVENTIVE MAINTENANCE CHECKS AND SERVICES FOR MODELS M939/A1/A2 (BIENNIAL).....	WP 0209
Table 1. Field Preventive Maintenance Checks and Services.....	0209-2
 Chapter 7 - MAINTENANCE INSTRUCTIONS	
SERVICE UPON RECEIPT.....	WP 0210
POWER PLANT REPLACEMENT (M939/A1).....	WP 0211
Figure 1. Sending Unit Disconnect.....	0211-2
Figure 2. Alternator Removal.....	0211-3
Figure 3. Hose Disconnect.....	0211-5
Figure 4. Power Plant Throttle Cable Removal.....	0211-7
Figure 5. Power Plant Engine Air Hoses Removal.....	0211-9
Figure 6. Power Plant Tachometer Cables Removal.....	0211-11
Figure 7. Power Plant Ether Cylinder Lines Removal.....	0211-13
Figure 8. Power Plant Starter Wires Removal.....	0211-15
Figure 9. Power Plant Transmission Shifter Cable Removal.....	0211-17
Figure 10. Power Plant Transmission Electrical Wires Removal.....	0211-19
Figure 11. Power Plant Transmission Module Removal.....	0211-21
Figure 12. Power Plant Ground Wires Removal.....	0211-23
Figure 13. Power Plant Engine Mounts Removal.....	0211-26
Figure 14. Power Plant Maintenance Stand.....	0211-27
Figure 15. Power Plant Water Cooler Removal.....	0211-28

TABLE OF CONTENTS - Continued

	Page No.
	<u>WP Sequence No.</u>
Figure 16. Power Plant Air Lines Assembly.....	0211-29
Figure 17. Power Plant Heater Shutoff Valves.....	0211-30
Figure 18. Power Plant Lifting Points.....	0211-31
Figure 19. Power Plant Engine Mounts Installation.....	0211-33
Figure 20. Power Plant Transmission Wires Installation.....	0211-35
Figure 21. Power Plant Transmission Module Installation.....	0211-37
Figure 22. Power Plant Transmission Shifter Cable Installation.....	0211-39
Figure 23. Power Plant Electrical Wire Installation.....	0211-41
Figure 24. Power Plant Air Line Installation.....	0211-43
Figure 25. Power Plant Ether Line Installation.....	0211-45
Figure 26. Power Plant Throttle Cable Installation.....	0211-47
Figure 27. Power Plant Power Steering Hoses Installation.....	0211-49
Figure 28. Power Plant Alternator Wiring Installation.....	0211-51
Figure 29. Power Plant Temperature Wiring Installation.....	0211-52
Figure 30. In-Chassis Run-In.....	0211-53
Figure 31. In-Chassis Run-In.....	0211-54
ENGINE AND CONTAINER REPLACEMENT.....	WP 0212
Figure 1. Engine and Container Removal.....	0212-2
Figure 2. Engine and Container Removal.....	0212-3
Figure 3. Engine and Container Installation.....	0212-5
Figure 4. Engine and Container Installation.....	0212-7
POWER PLANT REPLACEMENT (M939A2).....	WP 0213
Figure 1. Tachometer Cable and Drive Removal.....	0213-2
Figure 2. Air Intake System Removal.....	0213-3
Figure 3. Fuel Supply and Electrical System Removal.....	0213-5
Figure 4. Power System and Linkage Removal.....	0213-7
Figure 5. Air Compressor and Power Steering Line Removal.....	0213-8

TABLE OF CONTENTS - Continued

	Page No.
	<u>WP Sequence No.</u>
Figure 6. Alternator and Engine Harness Removal.....	0213-9
Figure 7. Starter Cable and Oil Cooler Hose Removal.....	0213-10
Figure 8. Oil Cooler Return Hose Removal.....	0213-11
Figure 9. Transmission Supply Hose Removal.....	0213-11
Figure 10. Coolant System Hose Removal.....	0213-13
Figure 11. Vent Tube and Sending Unit Lead Removal.....	0213-14
Figure 12. Transmission Cables and Electrical Lead Removal.....	0213-15
Figure 13. Transmission and Engine Mount Removal.....	0213-17
Figure 14. Power Plant Removal.....	0213-19
Figure 15. Power Plant Installation.....	0213-21
Figure 16. Transmission and Engine Mount Installation.....	0213-23
Figure 17. Transmission Shift Cable, Electrical Leads, Oil Cooler Return, and Supply Hose Installation.....	0213-25
Figure 18. Oil Cooler Return Hose Installation.....	0213-26
Figure 19. Transmission Supply Hose Installation.....	0213-26
Figure 20. Starter Lead And Water Heater Hoses Installation.....	0213-27
Figure 21. Alternator Lead Installation.....	0213-29
Figure 22. Air Line and Power Steering Hose Installation.....	0213-30
Figure 23. Fuel Pump Lines and Linkage Installation.....	0213-31
Figure 24. Fuel Supply and Electrical System Installation.....	0213-32
Figure 25. Air Intake, Tachometer Cable, and Drive Installation.....	0213-33
Figure 26. Priming Lube System.....	0213-34
Figure 27. Priming Lube System.....	0213-35
Figure 28. Priming Lube System.....	0213-37
Figure 29. Accelerator Linkage Adjustment.....	0213-38
ENGINE LIFT EYES REPLACEMENT (M939/A1).....	WP 0214
Figure 1. Engine Lift Eyes Removal.....	0214-2
Figure 2. Engine Lift Eyes Installation.....	0214-3

TABLE OF CONTENTS - Continued

	Page No.
	<u>WP Sequence No.</u>
ENGINE LIFTING BRACKETS REPLACEMENT (M939A2).....	WP 0215
Figure 1. Engine Lifting Brackets Removal.....	0215-1
Figure 2. Engine Lifting Brackets Installation.....	0215-2
ENGINE MOUNTING BRACKETS AND ISOLATORS REPLACEMENT.....	WP 0216
Figure 1. Engine Mounting Bracket Removal.....	0216-3
Figure 2. Engine Mounting Bracket Removal.....	0216-4
Figure 3. Engine Mounting Bracket Removal.....	0216-5
Figure 4. Engine Mounting Bracket Installation.....	0216-6
Figure 5. Engine Mounting Bracket Installation.....	0216-7
Figure 6. Engine Mounting Bracket Installation.....	0216-8
Figure 7. Engine Mounting Bracket Installation.....	0216-9
Figure 8. Engine Mounting Bracket Installation.....	0216-10
ENGINE ACCESS COVER REPLACEMENT (M939/A1).....	WP 0217
Figure 1. Engine Access Cover Removal.....	0217-2
Figure 2. Engine Access Cover Installation.....	0217-3
CRANKSHAFT VIBRATION DAMPENER REPLACEMENT (M939/A1).....	WP 0218
Figure 1. Vibration Dampener Runout and Wobble Check.....	0218-2
Figure 2. Vibration Dampener Removal.....	0218-3
Figure 3. Vibration Dampener Inspection.....	0218-4
Figure 4. Vibration Dampener Installation.....	0218-5
VIBRATION DAMPENER REPLACEMENT (M939A2).....	WP 0219
Figure 1. Vibration Dampener Removal.....	0219-3
Figure 2. Vibration Dampener Installation.....	0219-5
FLYWHEEL ASSEMBLY REPLACEMENT (M939/A1).....	WP 0220
Figure 1. Flywheel Assembly Removal.....	0220-2
Figure 2. Flywheel Assembly Installation.....	0220-3
FLEXPLATE AND FLYWHEEL ASSEMBLY REPLACEMENT (M939A2).....	WP 0221

TABLE OF CONTENTS - Continued

	Page No.
	<u>WP Sequence No.</u>
Figure 1. Flexplate and Flywheel Assembly Removal.....	0221-3
Figure 2. Flexplate and Flywheel Assembly Installation.....	0221-5
Figure 3. Flexplate and Flywheel Assembly Torque Sequence.....	0221-6
VALVE COVER REPLACEMENT (M939A2).....	WP 0222
Figure 1. Breather Tube Removal.....	0222-3
Figure 2. Radiator Inlet Tube Removal.....	0222-5
Figure 3. Surge Tank Assembly Removal.....	0222-7
Figure 4. Valve Cover Removal.....	0222-8
Figure 5. Valve Cover Installation.....	0222-11
Figure 6. Surge Tank Assembly Installation.....	0222-13
Figure 7. Radiator Inlet Tube Installation.....	0222-14
Figure 8. Breather Tube Installation.....	0222-15
Figure 9. Air Lines Installation.....	0222-16
CRANKCASE BREATHER AND TUBE REPLACEMENT (M939/A1/A2).....	WP 0223
Figure 1. Crankcase Breather and Tube Removal.....	0223-3
Figure 2. Crankcase Breather and Tube Removal.....	0223-5
Figure 3. Crankcase Breather and Tube Installation.....	0223-7
Figure 4. Crankcase Breather and Tube Installation.....	0223-9
OIL PUMP PICKUP HOSE REPLACEMENT (M939/A1).....	WP 0224
Figure 1. Oil Pump Pickup Hose Removal.....	0224-2
Figure 2. Oil Pump Pickup Hose Installation.....	0224-3
OIL PUMP RETURN HOSE REPLACEMENT (M939/A1).....	WP 0225
Figure 1. Oil Pump Return Hose Removal.....	0225-2
Figure 2. Oil Pump Return Hose Installation.....	0225-3
FRONT SUMP TUBE REPLACEMENT (M939/A1).....	WP 0226
Figure 1. Front Sump Tube Removal.....	0226-2
Figure 2. Front Sump Tube Installation.....	0226-4

TABLE OF CONTENTS - Continued

	Page No.
	<u>WP Sequence No.</u>
ENGINE SAMPLING VALVE REPLACEMENT.....	WP 0227
Figure 1. Engine Sampling Valve Removal.....	0227-2
Figure 2. Engine Sampling Valve Installation.....	0227-3
OIL DIPSTICK TUBE REPLACEMENT.....	WP 0228
Figure 1. Dipstick Tube Removal.....	0228-3
Figure 2. Dipstick Tube Installation.....	0228-5
ENGINE OIL COOLER MAINTENANCE (M939A2).....	WP 0229
Figure 1. Engine Oil Cooler Removal.....	0229-3
Figure 2. Engine Oil Cooler Disassembly.....	0229-5
Figure 3. Engine Oil Cooler Assembly.....	0229-7
Figure 4. Engine Oil Cooler Installation.....	0229-9
OIL PAN AND OIL SUCTION TUBE (M939A2).....	WP 0230
Figure 1. Oil Pan and Suction Tube Removal.....	0230-3
Figure 2. Oil Pan and Suction Tube Installation.....	0230-5
ENGINE OIL PAN REPLACEMENT (M939/A1).....	WP 0231
Figure 1. Engine Oil Pan Removal.....	0231-2
Figure 2. Engine Oil Pan Removal.....	0231-3
Figure 3. Engine Oil Pan Disassembly.....	0231-5
Figure 4. Engine Oil Pan Assembly.....	0231-7
Figure 5. Engine Oil Pan Installation.....	0231-9
Figure 6. Engine Oil Pan Installation.....	0231-10
ENGINE OIL FILTER REPLACEMENT.....	WP 0232
Figure 1. Engine Oil Drain Plugs.....	0232-2
Figure 2. Engine Oil Drain Plugs.....	0232-3
Figure 3. Engine Oil Drain Plugs.....	0232-4
Figure 4. Oil Filter Removal.....	0232-5
Figure 5. Oil Filter Removal.....	0232-5

TABLE OF CONTENTS - Continued

	Page No.
	<u>WP Sequence No.</u>
Figure 6. Filter Shell and Bolt Disassembly.....	0232-6
Figure 7. Engine Oil Filter Cleaning and Inspection.....	0232-7
Figure 8. Filter Shell and Bolt Assembly.....	0232-8
Figure 9. Engine Oil Filter Installation.....	0232-9
Figure 10. Engine Oil Filter Installation.....	0232-10
ENGINE OIL COOLER REPAIR (M939/A1).....	WP 0233
Figure 1. Engine Oil Cooler Removal.....	0233-3
Figure 2. Engine Oil Cooler Disassembly.....	0233-4
Figure 3. Engine Oil Cooler Cleaning and Inspection.....	0233-5
Figure 4. Engine Oil Cooler Assembly.....	0233-6
Figure 5. Engine Oil Cooler Installation.....	0233-7
ENGINE AIR INTAKE MANIFOLD REPLACEMENT (M939/A1).....	WP 0234
Figure 1. Engine Air Intake Manifold Removal.....	0234-3
Figure 2. Engine Air Intake Manifold Disassembly.....	0234-5
Figure 3. Engine Air Intake Manifold Assembly.....	0234-7
Figure 4. Engine Air Intake Manifold Installation.....	0234-9
ENGINE EXHAUST MANIFOLD REPLACEMENT (M939/A1).....	WP 0235
Figure 1. Engine Exhaust Manifold Removal.....	0235-3
Figure 2. Engine Exhaust Manifold Installation.....	0235-5
EXHAUST MANIFOLD REPLACEMENT (M939A2).....	WP 0236
Figure 1. Exhaust Manifold Removal.....	0236-1
Figure 2. Exhaust Manifold Installation.....	0236-2
Figure 3. Torque Sequence.....	0236-2
ENGINE ACCESSORY DRIVE AND PULLEY REPLACEMENT (M939/A1).....	WP 0237
Figure 1. Drive Pulley Removal.....	0237-2
Figure 2. Engine Drive Pulley Removal.....	0237-3
Figure 3. Drive Disassembly.....	0237-5

TABLE OF CONTENTS - Continued

	Page No.
	<u>WP Sequence No.</u>
Figure 4. Engine Accessory Cleaning and Inspection.....	0237-7
Figure 5. Drive Assembly.....	0237-9
Figure 6. Drive Installation.....	0237-10
Figure 7. Drive Installation.....	0237-11
Figure 8. Drive Installation.....	0237-12
Figure 9. Engine Accessory Drive and Pulley Installation.....	0237-13
FUEL INJECTOR REPLACEMENT (M939A2).....	WP 0238
Figure 1. Fuel Injector Removal.....	0238-3
Figure 2. Fuel Injector Installation.....	0238-4
PRIMING FUEL SYSTEM SERVICING (M939A2).....	WP 0239
Figure 1. Fuel System Priming.....	0239-3
FUEL PUMP REPLACEMENT (M939/A1).....	WP 0240
Figure 1. Fuel Pump Removal.....	0240-1
Figure 2. Fuel Pump Removal.....	0240-2
Figure 3. Fuel Pump Removal.....	0240-3
Figure 4. Fuel Pump Removal.....	0240-4
Figure 5. Fuel Pump Removal.....	0240-5
Figure 6. Fuel Pump Installation.....	0240-5
Figure 7. Fuel Pump Installation.....	0240-6
Figure 8. Fuel Pump Installation.....	0240-7
Figure 9. Fuel Pump Installation.....	0240-7
Figure 10. Fuel Pump Installation.....	0240-9
Figure 11. Fuel Pump Adjustments.....	0240-10
Figure 12. Fuel Pump Adjustments.....	0240-11
FUEL INJECTOR TUBES REPLACEMENT (M939A2).....	WP 0241
Figure 1. Fuel Injector Tubes Removal.....	0241-3
Figure 2. Fuel Injector Tubes Installation.....	0241-5

TABLE OF CONTENTS - Continued

	Page No.
	<u>WP Sequence No.</u>
FUEL INJECTION PUMP REPLACEMENT (M939A2).....	WP 0242
Figure 1. Fuel Injection Pump Removal.....	0242-3
Figure 2. Fuel Injection Pump Removal.....	0242-5
Figure 3. Fuel Injection Pump Removal.....	0242-6
Figure 4. Fuel Injection Pump Removal.....	0242-7
Figure 5. Fuel Injection Pump Removal.....	0242-9
Figure 6. Fuel Injection Pump Installation.....	0242-11
Figure 7. Fuel Injection Pump Installation.....	0242-12
Figure 8. Fuel Injection Pump Installation.....	0242-13
Figure 9. Fuel Injection Pump Installation.....	0242-15
Figure 10. Fuel Injection Pump Adjustment.....	0242-17
FUEL TRANSFER PUMP AND SUPPLY LINES REPLACEMENT (M939A2).....	WP 0243
Figure 1. Fuel Transfer Pump and Supply Lines Removal.....	0243-3
Figure 2. Fuel Transfer Pump and Supply Lines Installation.....	0243-5
AIR FUEL CONTROL (AFC) TUBE REPLACEMENT (M939A2).....	WP 0244
Figure 1. Air Fuel Control Tube Removal.....	0244-2
Figure 2. Air Fuel Control Tube Installation.....	0244-3
AIR CLEANER ASSEMBLY AND MOUNTING BRACKET REPLACEMENT.....	WP 0245
Figure 1. Air Cleaner Removal.....	0245-3
Figure 2. Air Cleaner Disassembly.....	0245-4
Figure 3. Air Cleaner Assembly.....	0245-5
Figure 4. Air Cleaner Installation.....	0245-7
AIR CLEANER INTAKE PIPE REPLACEMENT (M939/A1).....	WP 0246
Figure 1. Air Cleaner Intake Pipe Removal.....	0246-3
Figure 2. Air Cleaner Intake Pipe Installation.....	0246-5
AIR CLEANER INDICATOR AND TUBE REPLACEMENT.....	WP 0247
Figure 1. Air Cleaner Indicator and Tube Removal.....	0247-2

TABLE OF CONTENTS - Continued

	Page No.
	<u>WP Sequence No.</u>
Figure 2. Air Cleaner Indicator and Tube Removal.....	0247-3
Figure 3. Air Cleaner Indicator and Tube Installation.....	0247-4
Figure 4. Air Cleaner Indicator and Tube Installation.....	0247-5
AIR CLEANER HOSE MAINTENANCE (M939A2).....	WP 0248
Figure 1. Air Cleaner Hose Removal.....	0248-2
Figure 2. Air Cleaner Hose Disassembly.....	0248-3
Figure 3. Air Cleaner Hose Assembly.....	0248-4
Figure 4. Air Cleaner Hose Installation.....	0248-5
Figure 5. Air Cleaner Hose Inspection.....	0248-6
TURBOCHARGER HOSES AND CLAMPS REPLACEMENT (M939A2).....	WP 0249
Figure 1. Turbocharger Hoses and Clamps Removal.....	0249-2
Figure 2. Turbocharger Hoses and Clamps Removal.....	0249-3
Figure 3. Turbocharger Hoses and Clamps Removal.....	0249-5
Figure 4. Turbocharger Hoses and Clamps Installation.....	0249-7
Figure 5. Turbocharger Hoses and Clamps Installation.....	0249-8
Figure 6. Turbocharger Hoses and Clamps Installation.....	0249-9
FUEL TANK REPLACEMENT.....	WP 0250
Figure 1. Fuel Tank Removal.....	0250-3
Figure 2. Fuel Tank Removal.....	0250-3
Figure 3. Fuel Tank Fitting Removal.....	0250-4
Figure 4. Fuel Tank Installation.....	0250-5
Figure 5. Fuel Tank Installation.....	0250-6
Figure 6. Personnel Heater Fuel Line Installation.....	0250-7
FUEL TANK REPLACEMENT (M936/A1/A2).....	WP 0251
Figure 1. Fuel Tank Removal (M936/A1/A2).....	0251-3
Figure 2. Fuel Tank Components Removal/Installation.....	0251-5
Figure 3. Fuel Tank Components Installation.....	0251-7

TABLE OF CONTENTS - Continued

	Page No.
	<u>WP Sequence No.</u>
Figure 4. Fuel Tank Assembly.....	0251-9
Figure 5. Fuel Tank Installation.....	0251-10
FUEL TANK FILLER CAP AND SPOUT REPLACEMENT.....	WP 0252
Figure 1. Fuel Tank Filler Cap and Spout Removal.....	0252-3
Figure 2. Fuel Tank Filler Cap and Spout Installation.....	0252-5
FUEL TANK HANGERS AND RETAINING STRAPS REPLACEMENT.....	WP 0253
Figure 1. Fuel Tank Hangers and Retaining Straps Removal.....	0253-3
Figure 2. Fuel Tank Hangers and Retaining Straps Inspection.....	0253-5
Figure 3. Fuel Tank Hangers and Retaining Straps Installation.....	0253-7
FUEL TANK LINES REPLACEMENT (M939A2).....	WP 0254
Figure 1. Fuel Tank Lines Removal.....	0254-3
Figure 2. Fuel Return and Supply Lines Removal.....	0254-5
Figure 3. Fuel Return and Supply Lines Removal.....	0254-7
Figure 4. Fuel Return and Supply Lines Installation.....	0254-9
Figure 5. Fuel Return and Supply Lines Installation.....	0254-10
Figure 6. Fuel Return and Supply Lines Installation.....	0254-11
FUEL SELECTOR VALVE, MOUNTING BRACKET, AND INDICATOR PLATE REPLACEMENT.....	WP 0255
Figure 1. Fuel Selector Valve Removal.....	0255-3
Figure 2. Fuel Selector Valve Installation.....	0255-5
FUEL DRAIN AND BYPASS TUBING REPLACEMENT (M939/A1).....	WP 0256
Figure 1. Fuel Bypass Tubing Removal.....	0256-3
Figure 2. Fuel Bypass Tubing Removal.....	0256-5
Figure 3. Fuel Bypass Tubing Installation.....	0256-7
Figure 4. Fuel Bypass Tubing Installation.....	0256-9
FUEL SELECTOR VALVE FLEX HOSE REPLACEMENT.....	WP 0257
Figure 1. Fuel Selector Valve Flex Hose Removal.....	0257-3
Figure 2. Fuel Selector Valve Flex Hose Installation.....	0257-4

TABLE OF CONTENTS - Continued

	Page No.
	<u>WP Sequence No.</u>
FUEL FILTER AND COVER REPLACEMENT.....	WP 0258
Figure 1. Fuel Filter Removal.....	0258-3
Figure 2. Fuel Filter Removal.....	0258-5
Figure 3. Fuel Filter Removal.....	0258-6
Figure 4. Fuel Filter Removal.....	0258-7
Figure 5. Fuel Filter Cleaning and Inspection.....	0258-8
Figure 6. Fuel Filter Installation.....	0258-9
Figure 7. Fuel Filter Installation.....	0258-10
Figure 8. Fuel Filter Installation.....	0258-11
AFC FUEL PUMP FILTER REPLACEMENT (M939/A1).....	WP 0259
Figure 1. AFC Fuel Pump Filter Removal.....	0259-3
Figure 2. AFC Fuel Pump Filter Installation.....	0259-4
FUEL PUMP WITH VS GOVERNOR FILTER REPLACEMENT (M939/A1).....	WP 0260
Figure 1. Fuel Pump with VS Governor Filter Removal.....	0260-3
Figure 2. Fuel Pump with VS Governor Filter Installation.....	0260-4
FUEL PRIMER PUMP REPLACEMENT (M939/A1).....	WP 0261
Figure 1. Fuel Primer Pump Removal.....	0261-2
Figure 2. Fuel Primer Pump Installation.....	0261-3
ETHER START SWITCH REPLACEMENT (M939/A1).....	WP 0262
Figure 1. Ether Start Switch Removal.....	0262-2
Figure 2. Ether Start Switch Installation.....	0262-3
ETHER CYLINDER AND VALVE REPLACEMENT (M939/A1).....	WP 0263
Figure 1. Ether Cylinder Removal.....	0263-3
Figure 2. Ether Valve Removal.....	0263-4
Figure 3. Ether Valve Installation.....	0263-5
Figure 4. Ether Cylinder Installation.....	0263-6
ETHER THERMAL CLOSE VALVE AND BUSHING REPLACEMENT (M939/A1).....	WP 0264

TABLE OF CONTENTS - Continued

	Page No.
	<u>WP Sequence No.</u>
Figure 1. Ether Thermal Close Valve and Bushing Removal.....	0264-2
Figure 2. Ether Thermal Close Valve and Bushing Installation.....	0264-3
ETHER ATOMIZER REPLACEMENT (M939/A1).....	WP 0265
Figure 1. Ether Atomizer Removal.....	0265-2
Figure 2. Ether Atomizer Installation.....	0265-3
ETHER ATOMIZER AND TEMPERATURE SENSOR REPLACEMENT (M939A2).....	WP 0266
Figure 1. Ether Atomizer and Temperature Sensor Removal.....	0266-3
Figure 2. Ether Atomizer and Temperature Sensor Installation.....	0266-4
ETHER TUBING REPLACEMENT (M939/A1).....	WP 0267
Figure 1. Ether Tubing Removal.....	0267-3
Figure 2. Ether Tubing Installation.....	0267-5
ACCELERATOR LINKAGE REPLACEMENT (M939/A1).....	WP 0268
Figure 1. Accelerator Linkage Removal.....	0268-3
Figure 2. Accelerator Linkage Installation.....	0268-5
Figure 3. Accelerator Linkage Adjustment.....	0268-7
ACCELERATOR LINKAGE REPLACEMENT (M939A2).....	WP 0269
Figure 1. Accelerator Linkage Removal.....	0269-3
Figure 2. Accelerator Linkage Disassembly.....	0269-5
Figure 3. Accelerator Linkage Assembly.....	0269-7
Figure 4. Accelerator Linkage Installation.....	0269-9
Figure 5. Accelerator Linkage Adjustment.....	0269-11
THROTTLE CONTROL CABLE REPLACEMENT.....	WP 0270
Figure 1. Throttle Control Cable Removal.....	0270-3
Figure 2. Throttle Control Cable Installation.....	0270-5
EMERGENCY STOP CONTROL CABLE REPLACEMENT.....	WP 0271
Figure 1. Emergency Stop Control Cable Removal.....	0271-3
Figure 2. Emergency Stop Control Cable Installation.....	0271-5

TABLE OF CONTENTS - Continued

	Page No.
	<u>WP Sequence No.</u>
ACCELERATOR PEDAL, BRACKET, ROD, AND STOPSCREW REPLACEMENT.....	WP 0272
Figure 1. Accelerator Pedal Removal.....	0272-2
Figure 2. Accelerator Pedal Installation.....	0272-3
EXHAUST STACK REPLACEMENT.....	WP 0273
Figure 1. Exhaust Stack Removal.....	0273-2
Figure 2. Exhaust Stack Installation.....	0273-3
MUFFLER AND SHIELD REPLACEMENT.....	WP 0274
Figure 1. Muffler and Shield Removal.....	0274-3
Figure 2. Muffler and Shield Installation.....	0274-5
REAR EXHAUST PIPE, SUPPORT BRACKET, AND CAB HEAT SHIELD REPLACEMENT.....	WP 0275
Figure 1. Rear Exhaust Pipe, Support Bracket, and Cab Heat Shield Removal.....	0275-3
Figure 2. Rear Exhaust Pipe, Support Bracket, and Cab Heat Shield Installation.....	0275-5
FRONT EXHAUST PIPE REPLACEMENT.....	WP 0276
Figure 1. Front Exhaust Pipe Replacement.....	0276-3
Figure 2. Front Exhaust Pipe Installation.....	0276-5
RADIATOR AND MOUNTING HARDWARE REPLACEMENT (M939A2 ONLY).....	WP 0277
Figure 1. Radiator and Mounting Hardware Removal.....	0277-3
Figure 2. Radiator and Mounting Hardware Installation.....	0277-5
SURGE TANK, RADIATOR VENT HOSE, AND MANIFOLD RETURN HOSE REPLACEMENT (M939/A1).....	WP 0278
Figure 1. Radiator Vent and Manifold Return Hoses Removal.....	0278-3
Figure 2. Surge Tank Removal.....	0278-5
Figure 3. Surge Tank Installation.....	0278-7
Figure 4. Radiator Vent and Manifold Return Hoses Installation.....	0278-9
SURGE TANK AND BRACKET REPLACEMENT (M939A2).....	WP 0279
Figure 1. Surge Tank and Bracket Removal.....	0279-3
Figure 2. Surge Tank and Bracket Installation.....	0279-5
COOLANT HOSES AND TUBES REPLACEMENT (M939/A1).....	WP 0280

TABLE OF CONTENTS - Continued

	Page No.
	<u>WP Sequence No.</u>
Figure 1. Radiator Inlet Hoses and Tube Removal.....	0280-2
Figure 2. Thermostat Housing Hose, Radiator Bypass Tube, and Hose Removal.....	0280-3
Figure 3. Surge Tank Hose Removal.....	0280-4
Figure 4. Radiator Outlet Hoses and Tee Removal.....	0280-5
Figure 5. Transmission Oil Cooler Hoses and Tube Removal.....	0280-7
Figure 6. Transmission Oil Cooler Hoses and Tubes Installation.....	0280-9
Figure 7. Radiator Outlet Hoses and Tee Installation.....	0280-10
Figure 8. Surge Tank Hose Installation.....	0280-11
Figure 9. Thermostat Housing Hose, Radiator Bypass Tube, and Hose Installation.....	0280-12
Figure 10. Radiator Inlet Hoses and Tube Installation.....	0280-13
RADIATOR AND MOUNTING HARDWARE REPLACEMENT (M939/A1).....	WP 0281
Figure 1. Radiator (M939/A1) Removal.....	0281-2
Figure 2. Radiator (M939/A1) Removal.....	0281-3
Figure 3. Radiator (M939/A1) Removal.....	0281-4
Figure 4. Radiator (M939/A1) Installation.....	0281-5
Figure 5. Radiator (M939/A1) Installation.....	0281-6
Figure 6. Radiator (M939/A1) Installation.....	0281-7
RADIATOR FAN SHROUD REPLACEMENT (M939/A1).....	WP 0282
Figure 1. Radiator Fan Shroud Removal.....	0282-3
Figure 2. Radiator Fan Shroud Installation.....	0282-5
FAN AND FAN SHROUD REPAIR (M939A2).....	WP 0283
Figure 1. Fan and Shroud Removal.....	0283-3
Figure 2. Fan and Shroud Installation.....	0283-5
AIR COMPRESSOR COOLANT SUPPLY AND RETURN TUBES REPLACEMENT (M939/A1).....	WP 0284
Figure 1. Supply Tube Removal.....	0284-2
Figure 2. Return Tube Inspection.....	0284-3
Figure 3. Supply Tube Installation.....	0284-4

TABLE OF CONTENTS - Continued

	Page No.
	<u>WP Sequence No.</u>
Figure 4. Return Tube Installation.....	0284-5
COOLANT HOSES AND LINES REPLACEMENT (M939A2).....	WP 0285
Figure 1. Coolant Hoses and Lines Removal.....	0285-2
Figure 2. Coolant Hoses and Lines Removal.....	0285-3
Figure 3. Coolant Hoses and Lines Removal.....	0285-4
Figure 4. Coolant Hoses and Lines Removal.....	0285-5
Figure 5. Coolant Hoses and Lines Installation.....	0285-6
Figure 6. Coolant Hoses and Lines Installation.....	0285-7
Figure 7. Coolant Hoses and Lines Installation.....	0285-8
Figure 8. Coolant Hoses and Lines Installation.....	0285-9
UPPER RADIATOR HOSES AND BRACKETS REPLACEMENT (M939A2).....	WP 0286
Figure 1. Upper Radiator Hoses and Brackets Removal.....	0286-2
Figure 2. Upper Radiator Hoses and Brackets Removal.....	0286-3
Figure 3. Upper Radiator Hoses and Brackets Installation.....	0286-4
Figure 4. Upper Radiator Hoses and Brackets Installation.....	0286-5
COOLING SYSTEM SERVICE.....	WP 0287
Figure 1. Cooling System.....	0287-3
Table 1. Guide for Preparation of Antifreeze Solutions.....	0287-4
Figure 2. Cooling System.....	0287-5
THERMOSTAT AND HOUSING REPLACEMENT (M939/A1).....	WP 0288
Figure 1. Thermostat and Housing Removal.....	0288-3
Figure 2. Thermostat and Housing Installation.....	0288-5
THERMOSTATS AND HOUSING REPLACEMENT (M939A2).....	WP 0289
Figure 1. Thermostat and Housing Removal.....	0289-3
Figure 2. Thermostat and Housing Installation.....	0289-5
Figure 3. Thermostat and Housing Removal.....	0289-7
Figure 4. Thermostat and Housing Installation.....	0289-9

TABLE OF CONTENTS - Continued

	Page No.
	<u>WP Sequence No.</u>
ENGINE WATER MANIFOLD REPLACEMENT (M939/A1).....	WP 0290
Figure 1. Engine Water Manifold Removal.....	0290-3
Figure 2. Engine Water Manifold Disassembly.....	0290-4
Figure 3. Engine Water Manifold Assembly.....	0290-5
Figure 4. Engine Water Manifold Installation.....	0290-6
WATER HEADER PLATES REPLACEMENT (M939/A1).....	WP 0291
Figure 1. Water Header Plates Removal.....	0291-2
Figure 2. Water Header Plates Installation.....	0291-3
WATER PUMP REPLACEMENT (M939A2).....	WP 0292
Figure 1. Water Pump Removal.....	0292-2
Figure 2. Water Pump Installation.....	0292-3
WATER PUMP REPLACEMENT (M939/A1).....	WP 0293
Figure 1. Water Pump Removal.....	0293-2
Figure 2. Water Pump Removal.....	0293-3
Figure 3. Water Pump Installation.....	0293-4
Figure 4. Water Pump Installation.....	0293-5
WATER PUMP DRIVEBELT REPLACEMENT (M939/A1).....	WP 0294
Figure 1. Water Pump Drivebelt Adjustment.....	0294-3
Figure 2. Water Pump Drivebelt Removal.....	0294-5
Figure 3. Water Pump Drivebelt Installation.....	0294-7
FAN DRIVE CLUTCH REPLACEMENT (M939/A1).....	WP 0295
Figure 1. Fan Drive Clutch Removal.....	0295-1
Figure 2. Fan Drive Clutch Removal.....	0295-2
Figure 3. Fan Drive Clutch Installation.....	0295-3
Figure 4. Fan Drive Clutch Installation.....	0295-4
FAN DRIVEBELT AND DRIVEBELT TENSIONER REPLACEMENT (M939A2).....	WP 0296
Figure 1. Fan Drivebelt and Drivebelt Tensioner Removal.....	0296-3

TABLE OF CONTENTS - Continued

	Page No.
	<u>WP Sequence No.</u>
Figure 2. Fan Drivebelt and Drivebelt Tensioner Installation.....	0296-5
FAN DRIVEBELTS MAINTENANCE (M939/A1).....	WP 0297
Figure 1. Fan Drivebelt Adjustment.....	0297-3
Figure 2. Fan Drivebelt Removal.....	0297-5
Figure 3. Fan Drivebelt Installation.....	0297-6
RADIATOR FAN BLADE REPLACEMENT (M939/A1).....	WP 0298
Figure 1. Radiator Fan Blade Removal.....	0298-3
Figure 2. Radiator Fan Blade Installation.....	0298-5
AFTERCOOLER AND TUBES REPLACEMENT (M939A2).....	WP 0299
Figure 1. Aftercooler and Tubes Removal.....	0299-2
Figure 2. Aftercooler and Tubes Removal.....	0299-3
Figure 3. Aftercooler and Tubes Installation.....	0299-4
Figure 4. Aftercooler and Tubes Installation.....	0299-5
ALTERNATOR, MOUNTING BRACKET, AND PULLEY REPLACEMENT (M939/A1).....	WP 0300
Figure 1. Alternator and Mounting Bracket Removal.....	0300-2
Figure 2. Alternator and Mounting Bracket Removal.....	0300-3
Figure 3. Alternator Pulley Removal.....	0300-5
Figure 4. Alternator Pulley Installation.....	0300-7
Figure 5. Alternator and Mounting Bracket Installation.....	0300-8
Figure 6. Alternator and Mounting Bracket Installation.....	0300-9
ALTERNATOR, MOUNTING BRACKET, AND PULLEY REPLACEMENT (M939A2).....	WP 0301
Figure 1. Alternator and Mounting Bracket Removal.....	0301-3
Figure 2. Pulley Removal.....	0301-5
Figure 3. Pulley Installation.....	0301-7
Figure 4. Alternator and Mounting Bracket Installation.....	0301-9
Figure 5. Alternator, Mounting Bracket, and Pulley Adjustment.....	0301-11
ALTERNATOR DRIVEBELTS REPLACEMENT (M939/A1).....	WP 0302

TABLE OF CONTENTS - Continued

	Page No.
	<u>WP Sequence No.</u>
Figure 1. Alternator Drivebelts Removal.....	0302-2
Figure 2. Alternator Drivebelts Installation.....	0302-3
Figure 3. Alternator Drivebelts Installation.....	0302-3
Figure 4. Alternator Drivebelts Installation.....	0302-4
Figure 5. Alternator Drivebelts Installation.....	0302-4
STARTER REPLACEMENT.....	WP 0303
Figure 1. Starter Replacement Removal.....	0303-3
Figure 2. Starter Installation.....	0303-5
THROTTLE CONTROL SOLENOID REPLACEMENT (M939A2).....	WP 0304
Figure 1. Throttle Control Solenoid Removal.....	0304-2
Figure 2. Throttle Control Solenoid Installation.....	0304-3
FUEL PUMP METERING VALVE REPLACEMENT (M939/A1).....	WP 0305
Figure 1. Manual Shutoff Valve Removal.....	0305-2
Figure 2. Fuel Pump Metering Valve Removal.....	0305-3
Figure 3. Fuel Pump Metering Valve Installation.....	0305-4
Figure 4. Manual Shutoff Valve Installation.....	0305-5
FUEL PUMP METERING VALVE REPLACEMENT (M936 Wrecker).....	WP 0306
Figure 1. Fuel Pump Metering Valve Removal.....	0306-2
Figure 2. Fuel Pump Metering Valve Installation.....	0306-3
ELECTRICAL SWITCHES AND CIRCUIT BREAKER REPLACEMENT.....	WP 0307
Figure 1. Switch Removal.....	0307-1
Figure 2. Wire Removal.....	0307-2
Figure 3. Wire Connector Installation.....	0307-2
Figure 4. Blower Motor Switch Installation.....	0307-3
Figure 5. Battery and Switch Removal.....	0307-3
Figure 6. Battery and Starter Switch Removal.....	0307-4
Figure 7. Battery and Switch Installation.....	0307-5

TABLE OF CONTENTS - Continued

	Page No.
	<u>WP Sequence No.</u>
Figure 8. Battery and Starter Switch Installation.....	0307-5
Figure 9. Circuit Breaker Removal.....	0307-7
Figure 10. Circuit Breaker Installation.....	0307-9
SPRING BRAKE PRESSURE SWITCH REPLACEMENT.....	WP 0308
Figure 1. Spring Brake Pressure Switch Removal.....	0308-3
Figure 2. Spring Brake Pressure Switch Installation.....	0308-5
INSTRUMENT PANEL REPLACEMENT.....	WP 0309
Figure 1. Instrument Panel Removal.....	0309-3
Figure 2. Instrument Panel Installation.....	0309-4
INSTRUMENT CLUSTER REPLACEMENT.....	WP 0310
Figure 1. Cable Removal.....	0310-2
Figure 2. Cable Removal.....	0310-3
Figure 3. Instrument Cluster Removal.....	0310-4
Figure 4. Instrument Cluster Removal.....	0310-5
Figure 5. Instrument Cluster Disassembly.....	0310-7
Figure 6. Instrument Cluster Assembly.....	0310-9
Figure 7. Instrument Cluster Installation.....	0310-10
Figure 8. Instrument Cluster Installation.....	0310-11
Figure 9. Instrument Cluster Installation.....	0310-12
Figure 10. Instrument Cluster Installation.....	0310-13
INDICATOR PANEL LIGHT AND LAMP REPLACEMENT.....	WP 0311
Figure 1. Indicator Panel Light Removal.....	0311-2
Figure 2. Indicator Panel Light Installation.....	0311-3
Figure 3. Lamp Removal.....	0311-4
Figure 4. Lamp Installation.....	0311-5
ELECTRICAL GAUGES REPLACEMENT.....	WP 0312
Figure 1. Gauges Removal.....	0312-3

TABLE OF CONTENTS - Continued

	Page No.
	<u>WP Sequence No.</u>
Figure 2. Gauges Installation.....	0312-4
AUXILIARY OUTLET SOCKET AND RECEPTACLE REPLACEMENT.....	WP 0313
Figure 1. Auxiliary Outlet Socket and Receptacle Removal.....	0313-3
Figure 2. Auxiliary Outlet Installation.....	0313-5
FUEL SELECTOR VALVE SWITCH REPLACEMENT.....	WP 0314
Figure 1. Fuel Selector Valve Switch Removal.....	0314-3
Figure 2. Fuel Selector Valve Switch Installation.....	0314-5
MAIN LIGHT SWITCH REPLACEMENT.....	WP 0315
Figure 1. Main Light Switch Removal.....	0315-3
Figure 2. Main Light Switch Installation.....	0315-5
HIGH BEAM SELECTOR SWITCH REPLACEMENT.....	WP 0316
Figure 1. High Beam Selector Switch Removal.....	0316-1
Figure 2. High Beam Selector Switch Installation.....	0316-2
TURN SIGNAL CONTROL AND INDICATOR LAMP REPLACEMENT.....	WP 0317
Figure 1. Turn Signal Removal.....	0317-1
Figure 2. Turn Signal Installation.....	0317-2
TURN SIGNAL FLASHER REPLACEMENT.....	WP 0318
Figure 1. Turn Signal Removal.....	0318-1
Figure 2. Turn Signal Installation.....	0318-2
PROTECTIVE CONTROL BOX REPLACEMENT.....	WP 0319
Figure 1. Protective Control Box Removal.....	0319-2
Figure 2. Protective Control Box Installation.....	0319-3
FLOODLIGHT CONTROL SWITCH REPLACEMENT.....	WP 0320
Figure 1. Floodlight Switch Installation Removal.....	0320-2
Figure 2. Floodlight Switch Disassembly.....	0320-3
Figure 3. Floodlight Switch Inspection.....	0320-4
Figure 4. Floodlight Switch Assembly.....	0320-5

TABLE OF CONTENTS - Continued

	Page No.
	<u>WP Sequence No.</u>
Figure 5. Floodlight Switch Installation.....	0320-6
AMBER WARNING LIGHT REPLACEMENT.....	WP 0321
Figure 1. Amber Warning Light Removal.....	0321-1
Figure 2. Amber Warning Light Installation.....	0321-2
CTIS WIRING HARNESS REPLACEMENT.....	WP 0322
Figure 1. Wiring Harness Removal.....	0322-3
Figure 2. Wiring Harness Installation.....	0322-5
SPEED SIGNAL GENERATOR REPLACEMENT.....	WP 0323
Figure 1. Speed Signal Generator Removal.....	0323-2
Figure 2. Speed Signal Generator Installation.....	0323-3
PRESSURE SWITCH REPLACEMENT.....	WP 0324
Figure 1. Pressure Switch Removal.....	0324-2
Figure 2. Pressure Switch Installation.....	0324-3
HEADLIGHT REPAIR.....	WP 0325
Figure 1. Headlight Removal.....	0325-2
Figure 2. Headlight Removal.....	0325-3
Figure 3. Headlight Installation.....	0325-4
Figure 4. Headlight Installation.....	0325-5
Figure 5. Headlight Alignment.....	0325-6
BLACKOUT LIGHT REPAIR.....	WP 0326
Figure 1. Blackout Light Removal.....	0326-2
Figure 2. Blackout Light Disassembly.....	0326-3
Figure 3. Blackout Light Assembly.....	0326-4
Figure 4. Blackout Light Installation.....	0326-5
FRONT AND REAR COMPOSITE LIGHT AND BRACKET REPLACEMENT.....	WP 0327
Figure 1. Front Composite Light Removal.....	0327-3
Figure 2. Front Composite Light Installation.....	0327-4

TABLE OF CONTENTS - Continued

	Page No.
	<u>WP Sequence No.</u>
Figure 3. Rear Composite Light Removal.....	0327-5
Figure 4. Rear Composite Light Installation.....	0327-6
Figure 5. Rear Composite Light Removal.....	0327-7
Figure 6. Rear Composite Light Installation.....	0327-9
Figure 7. Rear Composite Light and Bracket Removal.....	0327-11
Figure 8. Rear Composite Light and Bracket Installation.....	0327-13
Figure 9. Rear Composite Light and Bracket Removal.....	0327-15
Figure 10. Rear Composite Light and Bracket Installation.....	0327-17
Figure 11. Rear Composite Light Removal.....	0327-19
Figure 12. Rear Composite Light Installation.....	0327-21
Figure 13. Rear Composite Bulb Removal.....	0327-22
Figure 14. Rear Composite Bulb Installation.....	0327-23
FLOODLIGHT SEALED BEAM LAMP AND DOOR REPLACEMENT.....	WP 0328
Figure 1. Floodlight Removal.....	0328-3
Figure 2. Floodlight Installation.....	0328-4
FLOODLIGHT REPAIR.....	WP 0329
Figure 1. Floodlight Removal.....	0329-2
Figure 2. Floodlight Disassembly.....	0329-3
Figure 3. Floodlight Disassembly.....	0329-4
Figure 4. Floodlight Assembly.....	0329-5
Figure 5. Floodlight Assembly.....	0329-6
Figure 6. Floodlight Installation.....	0329-7
SIDE MARKER LIGHTS AND BRACKET REPLACEMENT.....	WP 0330
Figure 1. Side Marker Lamp Removal.....	0330-2
Figure 2. Side Marker Light Removal.....	0330-3
Figure 3. Side Marker Light Installation.....	0330-4
Figure 4. Side Marker Lamp Installation.....	0330-5

TABLE OF CONTENTS - Continued

	Page No.
	<u>WP Sequence No.</u>
BOOM FLOODLIGHT WIRE REPLACEMENT.....	WP 0331
Figure 1. Boom Floodlight Wire Removal.....	0331-3
Figure 2. Boom Floodlight Wire Installation.....	0331-4
FUEL LEVEL SENDING UNIT REPLACEMENT.....	WP 0332
Figure 1. Fuel Level Sending Unit Removal.....	0332-3
Figure 2. Fuel Level Sending Unit Installation.....	0332-4
OIL PRESSURE SENDING UNIT REPLACEMENT.....	WP 0333
Figure 1. Oil Pressure Sending Unit Removal.....	0333-2
Figure 2. Oil Pressure Sending Unit Installation.....	0333-3
WATER TEMPERATURE SENDING UNIT REPLACEMENT.....	WP 0334
Figure 1. Water Temperature Sending Unit Removal.....	0334-2
Figure 2. Water Temperature Sending Unit Installation.....	0334-3
STOPLIGHT SWITCH REPLACEMENT.....	WP 0335
Figure 1. Stoplight Switch Removal.....	0335-1
Figure 2. Stoplight Switch Installation.....	0335-2
FAILSAFE WARNING MODULE REPLACEMENT.....	WP 0336
Figure 1. Failsafe Warning Module Removal.....	0336-2
Figure 2. Failsafe Warning Module Installation.....	0336-3
ETHER START FUEL PRESSURE SWITCH REPLACEMENT.....	WP 0337
Figure 1. Ether Start Fuel Pressure Switch Removal.....	0337-2
Figure 2. Ether Start Fuel Pressure Switch Installation.....	0337-3
TACHOMETER PULSE SENSOR REPLACEMENT.....	WP 0338
Figure 1. Tachometer Pulse Sender Removal.....	0338-2
Figure 2. Tachometer Pulse Sender Installation.....	0338-3
TACHOMETER PULSE SENSOR REPLACEMENT (M939A2).....	WP 0339
Figure 1. Tachometer Pulse Sender Removal.....	0339-1
Figure 2. Tachometer Pulse Sender Installation.....	0339-2

TABLE OF CONTENTS - Continued

	Page No.
	<u>WP Sequence No.</u>
FUEL PRESSURE TRANSDUCER REPLACEMENT.....	WP 0340
Figure 1. Fuel Pressure Transducer Removal.....	0340-2
Figure 2. Fuel Pressure Transducer Installation.....	0340-3
TRANSMISSION TEMPERATURE TRANSMITTER REPLACEMENT.....	WP 0341
Figure 1. Transmission Temperature Transmitter Removal.....	0341-1
Figure 2. Transmission Temperature Transmitter Installation.....	0341-2
PRIMARY AND SECONDARY LOW AIR PRESSURE SWITCH REPLACEMENT.....	WP 0342
Figure 1. Primary and Secondary Air Pressure Removal.....	0342-3
Figure 2. Primary and Secondary Air Pressure Removal.....	0342-5
Figure 3. Primary and Secondary Air Pressure Removal.....	0342-7
Figure 4. Primary and Secondary Air Pressure Installation.....	0342-9
HORN, SOLENOID, AND BRACKET REPLACEMENT.....	WP 0343
Figure 1. Horn, Solenoid, and Bracket Removal.....	0343-3
Figure 2. Horn, Solenoid, and Bracket Installation.....	0343-5
HORN SWITCH REPLACEMENT.....	WP 0344
Figure 1. Horn Switch Removal.....	0344-3
Figure 2. Horn Switch Installation.....	0344-5
HORN CONTACT BRUSH REPLACEMENT.....	WP 0345
Figure 1. Horn Contact Removal.....	0345-1
Figure 2. Horn Contact Removal.....	0345-3
Figure 3. Horn Contact Installation.....	0345-5
Figure 4. Horn Contact Installation.....	0345-6
BATTERY REPLACEMENT.....	WP 0346
Figure 1. Battery Removal.....	0346-3
Figure 2. Battery Inspection and Cleaning.....	0346-4
Figure 3. Battery Installation.....	0346-5
BATTERY BOX REPLACEMENT.....	WP 0347

TABLE OF CONTENTS - Continued

	Page No.
	<u>WP Sequence No.</u>
Figure 1. Battery Box Removal.....	0347-2
Figure 2. Battery Box Installation.....	0347-3
BATTERY BOX COVER REPLACEMENT.....	WP 0348
Figure 1. Battery Box Cover Removal.....	0348-2
Figure 2. Battery Box Cover Installation.....	0348-3
BATTERY CABLE AND TERMINAL ADAPTER REPLACEMENT.....	WP 0349
Figure 1. Battery Cable Removal.....	0349-3
Figure 2. Battery Cable Installation.....	0349-5
BATTERY GROUND CABLE REPLACEMENT.....	WP 0350
Figure 1. Battery Ground Cable Disconnection.....	0350-3
Figure 2. Battery Ground Cable Connection.....	0350-4
Index	
Volume 3	
Chapter 8 - MAINTENANCE INSTRUCTIONS	
INSTRUMENT CLUSTER HARNESS REPLACEMENT.....	WP 0351
Figure 1. Cluster Harness Removal.....	0351-2
Figure 2. Cluster Harness Installation.....	0351-3
WIRING HARNESS REPAIR.....	WP 0352
Figure 1. Terminal-Type Cable Connector.....	0352-2
Figure 2. Male Cable Connector.....	0352-3
Figure 3. Female Cable Connector.....	0352-3
Figure 4. Plug Assembly.....	0352-4
Figure 5. Receptacle Assembly.....	0352-5
SLAVE RECEPTACLE REPLACEMENT.....	WP 0353
Figure 1. Slave Receptacle Removal.....	0353-3
Figure 2. Slave Receptacle Installation.....	0353-5
GROUND STRAP REPLACEMENT.....	WP 0354

TABLE OF CONTENTS - Continued

	Page No.
	<u>WP Sequence No.</u>
Figure 1. Ground Strap Removal.....	0354-2
Figure 2. Ground Strap Removal.....	0354-3
Figure 3. Ground Strap Removal.....	0354-3
Figure 4. Ground Strap Installation.....	0354-4
Figure 5. Ground Strap Installation.....	0354-5
Figure 6. Ground Strap Installation.....	0354-6
Figure 7. Ground Strap Removal.....	0354-7
Figure 8. Ground Strap Removal.....	0354-8
Figure 9. Ground Strap Removal.....	0354-9
Figure 10. Ground Strap Installation.....	0354-10
Figure 11. Ground Strap Installation.....	0354-11
Figure 12. Ground Strap Installation.....	0354-12
CRANE WIRING HARNESS REPLACEMENT.....	WP 0355
Figure 1. Crane Wiring Harness Removal.....	0355-3
Figure 2. Crane Wiring Harness Installation.....	0355-5
FRONT LIGHTS CABLE ASSEMBLY REPLACEMENT (M939/A1).....	WP 0356
Figure 1. Front Lights Cable Assembly Removal.....	0356-3
Figure 2. Front Lights Cable Assembly Removal.....	0356-5
Figure 3. Front Lights Cable Assembly Installation.....	0356-7
Figure 4. Front Lights Cable Assembly Installation.....	0356-9
FRONT WIRING HARNESS REPLACEMENT (M939/A1).....	WP 0357
Figure 1. Front Wiring Harness Replacement.....	0357-3
Figure 2. Front Wiring Harness Replacement.....	0357-5
Figure 3. Front Wiring Harness Replacement.....	0357-7
Figure 4. Front Wiring Harness Replacement.....	0357-9
Figure 5. Front Wiring Harness Replacement.....	0357-11
Figure 6. Front Wiring Harness Replacement.....	0357-13

TABLE OF CONTENTS - Continued

	Page No.
	<u>WP Sequence No.</u>
Figure 7. Front Wiring Harness Replacement.....	0357-15
Figure 8. Front Wiring Harness Replacement.....	0357-17
Figure 9. Front Wiring Harness Replacement.....	0357-19
Figure 10. Front Wiring Harness Replacement.....	0357-21
Figure 11. Front Wiring Harness Replacement.....	0357-23
Figure 12. Front Wiring Harness Replacement.....	0357-25
Figure 13. Front Wiring Harness Replacement.....	0357-27
Figure 14. Front Wiring Harness Replacement.....	0357-28
Figure 15. Front Wiring Harness Replacement.....	0357-29
Figure 16. Front Wiring Harness Replacement.....	0357-30
Figure 17. Front Wiring Harness Replacement.....	0357-31
Figure 18. Front Wiring Harness Replacement.....	0357-33
Figure 19. Front Wiring Harness Replacement.....	0357-35
Figure 20. Front Wiring Harness Replacement.....	0357-37
Figure 21. Front Wiring Harness Replacement.....	0357-39
Figure 22. Front Wiring Harness Replacement.....	0357-41
Figure 23. Front Wiring Harness Replacement.....	0357-43
Figure 24. Front Wiring Harness Replacement.....	0357-45
Figure 25. Front Wiring Harness Replacement.....	0357-46
FRONT WIRING HARNESS REPLACEMENT (M939/A2).....	WP 0358
Figure 1. Front Wiring Harness Replacement.....	0358-3
Figure 2. Front Wiring Harness Replacement.....	0358-4
Figure 3. Front Wiring Harness Replacement.....	0358-5
Figure 4. Front Wiring Harness Replacement.....	0358-7
Figure 5. Front Wiring Harness Replacement.....	0358-9
Figure 6. Front Wiring Harness Replacement.....	0358-11
Figure 7. Front Wiring Harness Replacement.....	0358-13

TABLE OF CONTENTS - Continued

	Page No.
	<u>WP Sequence No.</u>
Figure 8. Front Wiring Harness Replacement.....	0358-14
Figure 9. Front Wiring Harness Replacement.....	0358-15
Figure 10. Front Wiring Harness Replacement.....	0358-17
Figure 11. Front Wiring Harness Replacement.....	0358-19
Figure 12. Front Wiring Harness Replacement.....	0358-21
Figure 13. Front Wiring Harness Replacement.....	0358-23
Figure 14. Front Wiring Harness Replacement.....	0358-25
Figure 15. Front Wiring Harness Replacement.....	0358-27
Figure 16. Front Wiring Harness Replacement.....	0358-29
Figure 17. Front Wiring Harness Replacement.....	0358-30
Figure 18. Front Wiring Harness Replacement.....	0358-31
Figure 19. Front Wiring Harness Replacement.....	0358-33
Figure 20. Front Wiring Harness Replacement.....	0358-35
REAR WIRING HARNESS REPLACEMENT.....	WP 0359
Figure 1. Rear Wiring Harness Replacement.....	0359-3
Figure 2. Rear Wiring Harness Replacement.....	0359-5
Figure 3. Rear Wiring Harness Replacement.....	0359-7
Figure 4. Rear Wiring Harness Replacement.....	0359-9
Figure 5. Rear Wiring Harness Replacement.....	0359-11
Figure 6. Rear Wiring Harness Replacement.....	0359-13
Table 1. Clamps Required for Rear Wiring Harness.....	0359-14
Figure 7. Rear Wiring Harness Replacement.....	0359-15
Figure 8. Rear Wiring Harness Replacement.....	0359-17
Figure 9. Rear Wiring Harness Replacement.....	0359-19
Figure 10. Rear Wiring Harness Replacement.....	0359-20
Figure 11. Rear Wiring Harness Replacement.....	0359-21
Figure 12. Rear Wiring Harness Replacement.....	0359-23

TABLE OF CONTENTS - Continued

	Page No.
	<u>WP Sequence No.</u>
Figure 13. Rear Wiring Harness Replacement.....	0359-24
Figure 14. Rear Wiring Harness Replacement.....	0359-25
Figure 15. Rear Wiring Harness Replacement.....	0359-27
Figure 16. Rear Wiring Harness Replacement.....	0359-28
Figure 17. Rear Wiring Harness Replacement.....	0359-29
SIDE MARKER LIGHTS WIRING HARNESS REPAIR.....	WP 0360
Figure 1. Side Marker Light Wiring Removal.....	0360-2
Figure 2. Side Marker Light Wiring Installation.....	0360-3
TRANSMISSION MOUNT AND BUSHING REPLACEMENT.....	WP 0361
Figure 1. Transmission Mount and Bushing Removal.....	0361-2
Figure 2. Transmission Mount and Bushing Installation.....	0361-3
TRANSMISSION OIL SERVICE INSTRUCTIONS.....	WP 0362
Figure 1. Oil Pan.....	0362-3
Figure 2. Oil Filter Removal.....	0362-5
Figure 3. Oil Filter Installation.....	0362-7
Figure 4. Oil Filter Installation.....	0362-9
Figure 5. Governor Filter Removal.....	0362-11
Figure 6. Governor Filter Installation.....	0362-13
Figure 7. Replenishing Oil.....	0362-15
TRANSMISSION DIPSTICK TUBE AND DIPSTICK REPLACEMENT.....	WP 0363
Figure 1. Dipstick Removal.....	0363-1
Figure 2. Dipstick Removal.....	0363-2
Figure 3. Dipstick Removal.....	0363-3
Figure 4. Dipstick Installation.....	0363-4
Figure 5. Dipstick Installation.....	0363-5
Figure 6. Dipstick Installation.....	0363-5
TRANSMISSION MOUNTING BRACKET AND ISOLATOR (M939A2) REPLACEMENT.....	WP 0364

TABLE OF CONTENTS - Continued

	Page No.
	<u>WP Sequence No.</u>
Figure 1. Mounting Bracket Removal.....	0364-2
Figure 2. Mounting Bracket Installation.....	0364-3
TRANSMISSION MODULATOR AND CABLE REPLACEMENT.....	WP 0365
Figure 1. Modulator and Cable Removal.....	0365-3
Figure 2. Modulator and Cable Installation.....	0365-5
Figure 3. Modulator and Cable Adjustment.....	0365-7
TRANSMISSION NEUTRAL START SWITCH REPLACEMENT.....	WP 0366
Figure 1. Transmission Neutral Start Switch Removal.....	0366-1
Figure 2. Transmission Neutral Start Switch Installation.....	0366-2
GOVERNOR PIPING AND CAPACITOR REPLACEMENT.....	WP 0367
Figure 1. Governor Piping Removal.....	0367-3
Figure 2. Capacitor Removal.....	0367-4
Figure 3. Governor Piping Removal.....	0367-5
Figure 4. Governor Piping Installation.....	0367-6
Figure 5. Capacitor Installation.....	0367-7
Figure 6. Governor Piping Installation.....	0367-9
TRANSMISSION 5TH GEAR LOCK-UP PRESSURE SWITCH REPLACEMENT.....	WP 0368
Figure 1. Pressure Switch Removal.....	0368-2
Figure 2. Pressure Switch Installation.....	0368-3
TRANSMISSION SELECT LEVER REPLACEMENT.....	WP 0369
Figure 1. Transmission Select Lever Removal.....	0369-3
Figure 2. Transmission Select Lever Installation.....	0369-5
TRANSMISSION SHIFT TOWER REPLACEMENT.....	WP 0370
Figure 1. Transmission Shift Tower Removal.....	0370-3
Figure 2. Transmission Shift Tower Installation.....	0370-5
TRANSMISSION SHIFT CABLE REPLACEMENT.....	WP 0371
Figure 1. Transmission Shift Cable Removal.....	0371-2

TABLE OF CONTENTS - Continued

	Page No.
	<u>WP Sequence No.</u>
Figure 2. Shift Tower Removal.....	0371-3
Figure 3. Engine Cover Removal.....	0371-4
Figure 4. Engine Cover Installation.....	0371-5
Figure 5. Shift Tower Installation.....	0371-6
Figure 6. Shift Cable Installation.....	0371-7
Figure 7. Shift Cable Installation.....	0371-9
TRANSMISSION REPLACEMENT (OUT-OF-VEHICLE).....	WP 0372
Figure 1. Flywheel Housing and Transmission Removal.....	0372-3
Figure 2. Transmission and Torque Convert Removal.....	0372-5
Figure 3. Transmission and Torque Converter Installation.....	0372-7
Figure 4. Flywheel and Flywheel Housing Cover Plate Installation.....	0372-8
TRANSMISSION REPLACEMENT (IN-VEHICLE).....	WP 0373
Figure 1. Transmission Flange Clamp and Wire Removal.....	0373-2
Figure 2. Transmission Support Bracket Removal.....	0373-3
Figure 3. Transmission and Torque Converter Removal.....	0373-5
Figure 4. Transmission and Torque Converter Removal.....	0373-7
Figure 5. Transmission and Torque Converter Installation.....	0373-9
Figure 6. Torque Converter Installation.....	0373-10
Figure 7. Transmission Power Takeoff Installation.....	0373-11
Figure 8. Transmission Flange Clamp and Wire Installation.....	0373-12
TRANSMISSION OIL PRESSURE TESTING.....	WP 0374
Figure 1. Oil Cooler Pressure Test.....	0374-3
Figure 2. Oil Cooler Pressure Test.....	0374-5
Figure 3. Oil Cooler Pressure Test.....	0374-7
Figure 4. Main Pressure and Governor Pressure Test.....	0374-9
Figure 5. Main Pressure and Governor Pressure Test.....	0374-10
Figure 6. Main Pressure and Governor Pressure Test.....	0374-11

TABLE OF CONTENTS - Continued

	Page No.
	<u>WP Sequence No.</u>
Figure 7. Main Pressure and Governor Pressure Test.....	0374-12
Figure 8. Main Pressure and Governor Pressure Test.....	0374-13
Figure 9. Main Pressure and Governor Pressure Test.....	0374-14
Table 1. Transmission Shift Point Check.....	0374-15
Figure 10. Main Pressure and Governor Pressure Adjustment.....	0374-17
Figure 11. Transmission Oil Pressure Adjustment.....	0374-17
Figure 12. Transmission Module Testing and Adjustment.....	0374-18
TRANSMISSION SELECTOR SHAFT OIL SEAL REPLACEMENT.....	WP 0375
Figure 1. Manual Control Linkage Removal.....	0375-2
Figure 2. Seal Remover Removal.....	0375-3
Figure 3. Manual Control Linkage Installation.....	0375-5
TRANSMISSION OUTPUT SHAFT YOKE AND OIL SEAL REPLACEMENT.....	WP 0376
Figure 1. Transmission Output Shaft Yoke and Oil Seal Removal.....	0376-2
Figure 2. Transmission Output Shaft Yoke and Oil Seal Installation.....	0376-3
TRANSMISSION OIL PAN AND FILTER REPLACEMENT.....	WP 0377
Figure 1. Transmission Oil Pan and Filter Removal.....	0377-3
Figure 2. Transmission Oil Pan and Filter Removal.....	0377-5
Figure 3. Transmission Oil Pan and Filter Installation.....	0377-7
Figure 4. Transmission Oil Pan and Filter Installation.....	0377-8
TRANSMISSION LUBRICATION VALVE REPLACEMENT.....	WP 0378
Figure 1. Front Winch Hoses Removal.....	0378-2
Figure 2. Transmission Lubrication Valve Removal.....	0378-3
Figure 3. Transmission Lubrication Valve Installation.....	0378-4
Figure 4. Transmission Lubrication Valve Installation.....	0378-5
Figure 5. Front Winch Hoses Installation.....	0378-5
TRANSMISSION FIFTH GEAR LOCK-IN SOLENOID REPLACEMENT.....	WP 0379
Figure 1. Transmission Fifth Gear Lock-in Solenoid Removal.....	0379-3

TABLE OF CONTENTS - Continued

	Page No.
	<u>WP Sequence No.</u>
Figure 2. Governor and Main Pressure Lines Installation.....	0379-4
TRANSMISSION OIL COOLER AND MOUNT REPLACEMENT (M939/A1).....	WP 0380
Figure 1. Oil Cooler Removal.....	0380-2
Figure 2. Oil Cooler Removal.....	0380-3
Figure 3. Oil Cooler Removal.....	0380-3
Figure 4. Oil Cooler Removal.....	0380-4
TRANSMISSION OIL COOLER FILTER AND HEAD REPAIR.....	WP 0381
Figure 1. Oil Cooler Filter Removal.....	0381-2
Figure 2. Oil Filter Cooler Head Removal.....	0381-3
Figure 3. Oil Cooler Filter Head Installation.....	0381-4
Figure 4. Oil Cooler Filter Installation.....	0381-5
TRANSMISSION OIL COOLER HOSES REPLACEMENT.....	WP 0382
Figure 1. Oil Cooler Hoses Removal.....	0382-3
Figure 2. Oil Cooler Hoses Removal.....	0382-4
Figure 3. Oil Cooler Hoses Removal.....	0382-5
Figure 4. Oil Cooler Hoses Removal.....	0382-7
Figure 5. Oil Cooler Hoses Installation.....	0382-9
Figure 6. Oil Cooler Hoses Installation.....	0382-10
Figure 7. Oil Cooler Hoses Installation.....	0382-11
Figure 8. Oil Cooler Hoses Installation.....	0382-12
TRANSMISSION OIL COOLER AND MOUNT REPLACEMENT (M939A2).....	WP 0383
Figure 1. Oil Cooler and Mount Removal.....	0383-3
Figure 2. Oil Cooler and Mount Installation.....	0383-5
TRANSMISSION BREATHER REPLACEMENT.....	WP 0384
Figure 1. Transmission Breather Removal.....	0384-2
Figure 2. Transmission Breather Installation.....	0384-3
TRANSFER CASE REPLACEMENT (ALL EXCEPT M936/A1/A2).....	WP 0385

TABLE OF CONTENTS - Continued

	Page No.
	<u>WP Sequence No.</u>
Figure 1. Transfer Case Components Removal.....	0385-2
Figure 2. Transfer Case Brackets and Fittings Removal.....	0385-3
Figure 3. Transfer Case Brackets and Fittings Removal.....	0385-4
Figure 4. Transfer Case Components Removal.....	0385-5
Figure 5. Transfer Case Components Removal.....	0385-6
Figure 6. Transfer Case Brackets and Fittings Removal.....	0385-7
Figure 7. Transfer Case Brackets and Fittings Removal.....	0385-9
Figure 8. Transfer Case Brackets and Fittings Installation.....	0385-11
Figure 9. Transfer Case Components Installation.....	0385-12
Figure 10. Transfer Case Components Installation.....	0385-13
Figure 11. Transfer Case Components Installation.....	0385-14
Figure 12. Transfer Case Components Installation.....	0385-15
Figure 13. Transfer Case Components Installation.....	0385-16
Figure 14. Transfer Case Cables Installation.....	0385-17
TRANSFER CASE REPLACEMENT (M936/A1/A2).....	WP 0386
Figure 1. Transfer Case Power Takeoff Removal.....	0386-2
Figure 2. Transfer Case Power Takeoff Removal.....	0386-3
Figure 3. Transfer Case Power Takeoff Removal.....	0386-5
Figure 4. Transfer Case Power Takeoff Removal.....	0386-6
Figure 5. Transfer Case Power Takeoff Removal.....	0386-7
Figure 6. Transfer Case Power Takeoff Removal.....	0386-8
Figure 7. Transfer Case Lines and Cables Removal.....	0386-9
Figure 8. Transfer Case Brackets Removal.....	0386-11
Figure 9. Transfer Case Brackets Removal.....	0386-13
Figure 10. Transfer Case Brackets Installation.....	0386-15
Figure 11. Transfer Case Brackets Installation.....	0386-16
Figure 12. Transfer Case Lines and Cables Installation.....	0386-17

TABLE OF CONTENTS - Continued

	Page No.
	<u>WP Sequence No.</u>
Figure 13. Transfer Case Lines and Cables Installation.....	0386-18
Figure 14. Transfer Case Lines and Cables Installation.....	0386-19
Figure 15. Transfer Case Lines and Cables Installation.....	0386-20
Figure 16. Transfer Case Lines and Cables Installation.....	0386-21
Figure 17. Transfer Case Power Takeoff Installation.....	0386-22
Figure 18. Transfer Case Power Takeoff Installation.....	0386-23
Figure 19. Transfer Case Power Takeoff Installation.....	0386-24
TRANSFER CASE SPEEDOMETER DRIVE GEAR AND DRIVEN SHAFT REPLACEMENT.....	WP 0387
Figure 1. Transfer Case Speedometer Drive Gear and Driven Shaft Removal.....	0387-3
Figure 2. Transfer Case Speedometer Drive Gear and Driven Shaft Installation.....	0387-4
TRANSFER CASE FRONT AXLE ENGAGEMENT CONTROL VALVE REPLACEMENT.....	WP 0388
Figure 1. Transfer Case Front Axle Engagement Valve Removal.....	0388-2
Figure 2. Transfer Case Front Axle Engagement Valve Installation.....	0388-3
TRANSFER CASE FRONT AXLE LOCK-IN CONTROL VALVE REPLACEMENT.....	WP 0389
Figure 1. Control Valve Removal.....	0389-3
Figure 2. Control Valve Installation.....	0389-4
TRANSFER CASE INTERLOCK AIR CYLINDER REPLACEMENT.....	WP 0390
Figure 1. Transfer Case Interlock Air Cylinder Removal.....	0390-3
Figure 2. Transfer Case Interlock Air Cylinder Installation.....	0390-4
TRANSFER CASE FRONT AXLE ENGAGEMENT AIR CYLINDER REPLACEMENT.....	WP 0391
Figure 1. Transfer Case Front Axle Engagement Air Cylinder Removal.....	0391-3
Figure 2. Transfer Case Front Axle Engagement Air Cylinder Installation.....	0391-5
FRONT-WHEEL DRIVE LOCK-IN SWITCH REPLACEMENT.....	WP 0392
Figure 1. Front-Wheel Drive Lock-In Switch Removal.....	0392-3
Figure 2. Front-Wheel Drive Lock-In Switch Installation.....	0392-4
FRONT WHEEL VALVE REPLACEMENT (M939A2).....	WP 0393
Figure 1. Front Wheel Valve Removal.....	0393-3

TABLE OF CONTENTS - Continued

	Page No.
	<u>WP Sequence No.</u>
Figure 2. Front Wheel Valve Installation.....	0393-5
TRANSFER CASE INTERLOCK VALVE REPLACEMENT (ALL EXCEPT M936/A1/A2).....	WP 0394
Figure 1. Transfer Case Interlock Valve Removal (Except M936/A1/A2).....	0394-3
Figure 2. Transfer Case Interlock Valve Installation (Except M936/A1/A2).....	0394-5
TRANSFER CASE INTERLOCK VALVE REPLACEMENT (M936/A1/A2).....	WP 0395
Figure 1. Transfer Case Interlock Valve Removal (M936/A1/A2).....	0395-2
Figure 2. Transfer Case Interlock Valve Installation (M936/A1/A2).....	0395-3
TRANSFER CASE CONTROLS AND LINKAGE REPAIR.....	WP 0396
Figure 1. Transfer Case Shift Lever Removal.....	0396-3
Figure 2. Transfer Case Shift Lever Installation.....	0396-4
Figure 3. Transfer Case Shift Lever Shift Rod Removal.....	0396-5
Figure 4. Transfer Case Shift Lever Shift Rod Installation.....	0396-6
Figure 5. Transfer Case Cross Shaft Removal.....	0396-7
Figure 6. Transfer Case Cross Shaft Installation.....	0396-9
Figure 7. Transfer Case Shift Rod Removal.....	0396-11
Figure 8. Transfer Case Shift Rod Installation.....	0396-12
Figure 9. Transfer Case Switch Removal.....	0396-13
Figure 10. Transfer Case Switch Installation.....	0396-14
TRANSFER CASE CAPACITOR REPLACEMENT.....	WP 0397
Figure 1. Transfer Case Capacitor Removal.....	0397-2
Figure 2. Transfer Case Capacitor Installation.....	0397-3
TRANSFER CASE TRANSORB DIODE REPLACEMENT.....	WP 0398
Figure 1. Transfer Case Transorb Diode Removal.....	0398-3
Figure 2. Transfer Case Transorb Diode Installation.....	0398-4
TRANSFER CASE OIL PUMP REPLACEMENT.....	WP 0399
Figure 1. Transfer Case Oil Pump Removal.....	0399-2
Figure 2. Transfer Case Oil Pump Installation.....	0399-3

TABLE OF CONTENTS - Continued

	Page No.
	<u>WP Sequence No.</u>
FORWARD-REAR TO REAR-REAR PROPELLER SHAFT REPLACEMENT.....	WP 0400
Figure 1. Rear Propeller Shaft Removal.....	0400-2
Figure 2. Rear Propeller Shaft Installation.....	0400-3
TRANSFER CASE TO FORWARD-REAR AXLE PROPELLER SHAFT REPAIR.....	WP 0401
Figure 1. Forward-Rear Propeller Shaft Removal.....	0401-3
Figure 2. Propeller Shaft and Bracket Removal.....	0401-5
Figure 3. Propeller Shaft Disassembly.....	0401-7
Figure 4. Propeller Shaft Assembly.....	0401-9
Figure 5. Propeller Shaft and Bracket Installation.....	0401-11
Figure 6. Propeller Shaft Installation.....	0401-13
TRANSFER CASE TO FRONT AXLE PROPELLER SHAFT REPAIR.....	WP 0402
Figure 1. Propeller Shaft Removal.....	0402-3
Figure 2. Propeller Shaft Installation.....	0402-5
TRANSMISSION TO TRANSFER CASE PROPELLER SHAFT REPAIR.....	WP 0403
Figure 1. Transmission To Transfer Case Propeller Shaft Removal.....	0403-2
Figure 2. Propeller Shaft Removal.....	0403-3
Figure 3. Yoke Disassembly.....	0403-4
Figure 4. Yoke Disassembly.....	0403-4
Figure 5. Yoke Assembly.....	0403-5
Figure 6. Yoke Assembly.....	0403-5
Figure 7. Propellor Shaft Installation.....	0403-6
Figure 8. Propellor Shaft Installation.....	0403-7
FRONT AXLE REPLACEMENT.....	WP 0404
Figure 1. Front Axle Removal.....	0404-3
Figure 2. Front Axle Removal.....	0404-5
Figure 3. Front Axle Installation.....	0404-7
Figure 4. Front Axle Installation.....	0404-9

TABLE OF CONTENTS - Continued

	Page No.
	<u>WP Sequence No.</u>
FRONT AXLE BREATHER REPLACEMENT.....	WP 0405
Figure 1. Front Axle Breather Removal.....	0405-1
Figure 2. Front Axle Breather Installation.....	0405-2
FRONT AND REAR AXLE CARRIER DIFFERENTIAL REPLACEMENT.....	WP 0406
Figure 1. Front and Rear Axle Carrier Differential Removal.....	0406-3
Figure 2. Front and Rear Axle Carrier Differential Installation.....	0406-4
FRONT DIFFERENTIAL OIL SEAL REPLACEMENT.....	WP 0407
Figure 1. Front Differential Oil Seal Removal.....	0407-2
Figure 2. Front Differential Oil Seal Installation.....	0407-3
FRONT AXLE DRIVE COMPANION FLANGE REPLACEMENT.....	WP 0408
Figure 1. Front Axle Drive Companion Flange Removal.....	0408-1
Figure 2. Front Axle Drive Companion Flange Inspection.....	0408-2
Figure 3. Front Axle Drive Companion Flange Installation.....	0408-3
STEERING KNUCKLE BOOT REPLACEMENT.....	WP 0409
Figure 1. Steering Knuckle Boot Removal.....	0409-1
Figure 2. Steering Knuckle Boot Removal.....	0409-2
Figure 3. Steering Knuckle Boot Installation.....	0409-3
Figure 4. Steering Knuckle Boot Installation.....	0409-4
FRONT AXLE SEAL REPLACEMENT.....	WP 0410
Figure 1. Front Axle Seal Removal.....	0410-2
Figure 2. Front Axle Seal Installation.....	0410-3
FRONT AXLE SHAFT AND UNIVERSAL JOINT REPLACEMENT.....	WP 0411
Figure 1. Front Axle Shaft Removal.....	0411-3
Figure 2. Front Axle Shaft Inspection.....	0411-4
Figure 3. Front Axle Shaft Inspection.....	0411-5
Figure 4. Front Axle Shaft Installation.....	0411-7
STEERING KNUCKLE REPAIR.....	WP 0412

TABLE OF CONTENTS - Continued

	Page No.
	<u>WP Sequence No.</u>
Figure 1. Steering Knuckle Removal.....	0412-3
Figure 2. Steering Knuckle Cleaning/Inspection.....	0412-5
Figure 3. Steering Knuckle Installation.....	0412-7
Figure 4. Steering Knuckle Installation.....	0412-9
Figure 5. End Play Test.....	0412-11
SPINDLE BEARING SLEEVE REPLACEMENT.....	WP 0413
Figure 1. Spindle Bearing Sleeve Removal.....	0413-1
Figure 2. Spindle Bearing Sleeve Installation.....	0413-2
FORWARD-REAR AND REAR-REAR AXLE REPLACEMENT.....	WP 0414
Figure 1. Forward-Rear and Rear-Rear Axle Removal.....	0414-3
Figure 2. Axle on Jack Stand Removal.....	0414-5
Figure 3. Axle on Jack Stand Removal.....	0414-7
Figure 4. Forward-Rear and Rear-Rear Brackets Installation.....	0414-9
Figure 5. Forward-Rear and Rear-Rear Brackets Installation.....	0414-11
Figure 6. Axle Lines and Fittings Installation.....	0414-12
Figure 7. Axle Lines and Fittings Installation.....	0414-13
FORWARD-REAR AND REAR-REAR AXLE LEAKAGE TEST.....	WP 0415
Figure 1. Axle Leakage Test.....	0415-3
REAR AXLE BREATHER REPLACEMENT.....	WP 0416
Figure 1. Rear Axle Breather Removal.....	0416-1
Figure 2. Rear Axle Breather Installation.....	0416-2
REAR AXLE SHAFT REPLACEMENT.....	WP 0417
Figure 1. Rear Axle Shaft Removal.....	0417-1
Figure 2. Rear Axle Shaft Installation.....	0417-2
REAR DIFFERENTIAL OIL SEAL REPLACEMENT.....	WP 0418
Figure 1. Rear Differential Oil Seal Removal.....	0418-2
Figure 2. Rear Differential Oil Seal Installation.....	0418-3

TABLE OF CONTENTS - Continued

	Page No.
	<u>WP Sequence No.</u>
CARRIER DIFFERENTIAL TOP COVER GASKET AND SIDE COVER GASKET REPLACEMENT.....	WP 0419
Figure 1. Top Cover Gasket Removal.....	0419-2
Figure 2. Top Cover Gasket Removal.....	0419-3
Figure 3. Top Cover Gasket Installation.....	0419-4
Figure 4. Top Cover Gasket Installation.....	0419-5
Figure 5. Side Cover Gasket Removal.....	0419-6
Figure 6. Side Cover Gasket Installation.....	0419-7
PARKING BRAKE ADJUSTMENT.....	WP 0420
Figure 1. Parking Brake Test.....	0420-2
Figure 2. Parking Brake Minor Adjustment.....	0420-3
Figure 3. Parking Brake Major Adjustment.....	0420-4
Figure 4. Parking Brake Lever Arm Adjustment.....	0420-5
PARKING BRAKE CABLE AND BRACKET REPLACEMENT.....	WP 0421
Figure 1. Parking Brake Cable and Bracket Removal.....	0421-2
Figure 2. Parking Brake Cable and Bracket Removal.....	0421-3
Figure 3. Parking Brake Cable and Bracket Installation.....	0421-4
Figure 4. Parking Brake Cable and Bracket Installation.....	0421-5
PARKING BRAKE SHOES REPLACEMENT.....	WP 0422
Figure 1. Parking Brake Shoe Removal.....	0422-2
Figure 2. Parking Brake Shoe Removal.....	0422-3
Figure 3. Parking Brake Shoe Cleaning and Inspection.....	0422-4
Figure 4. Parking Brake Shoe Installation.....	0422-5
Figure 5. Parking Brake Shoe Installation.....	0422-6
PARKING BRAKE DRUM DUST COVER REPLACEMENT.....	WP 0423
Figure 1. Parking Brake Drum Dust Cover Removal.....	0423-2
Figure 2. Parking Brake Drum Dust Cover Installation.....	0423-3
WHEEL BRAKE DRUM DUST COVERS REPLACEMENT.....	WP 0424

TABLE OF CONTENTS - Continued

	Page No.
	<u>WP Sequence No.</u>
Figure 1. Wheel Dust Covers Removal.....	0424-2
Figure 2. Wheel Dust Covers Removal.....	0424-3
Figure 3. Wheel Dust Covers Installation.....	0424-4
Figure 4. Wheel Dust Covers Installation.....	0424-5
PARKING BRAKE LEVER REPLACEMENT.....	WP 0425
Figure 1. Parking Brake Lever Removal.....	0425-3
Figure 2. Parking Brake Lever Installation.....	0425-5
BRAKE SHOE REPLACEMENT.....	WP 0426
Figure 1. Brake Shoe Removal.....	0426-2
Figure 2. Brake Shoe Installation.....	0426-3
FRONT BRAKE SPIDER AND ACTUATOR REPAIR.....	WP 0427
Figure 1. Front Brake Spider Removal.....	0427-3
Figure 2. Actuators Disassembly.....	0427-5
Figure 3. Actuators Assembly.....	0427-9
Figure 4. Front Brake Spider Installation.....	0427-11
REAR BRAKE SPIDER AND ACTUATOR REPAIR.....	WP 0428
Figure 1. Rear Brake Spider Removal.....	0428-2
Figure 2. Rear Brake Actuator Disassembly.....	0428-3
Figure 3. Seal Assembly.....	0428-5
Figure 4. Seal Assembly.....	0428-6
Figure 5. Rear Brake Actuator Assembly.....	0428-7
Figure 6. Rear Brake Spider Installation.....	0428-9
BRAKE PEDAL (TREADLE) VALVE REPLACEMENT (ALL EXCEPT M936/A1/A2).....	WP 0429
Figure 1. Brake Pedal Removal.....	0429-2
Figure 2. Brake Pedal Removal.....	0429-3
Figure 3. Brake Pedal Removal.....	0429-4
Figure 4. Brake Pedal Removal.....	0429-5

TABLE OF CONTENTS - Continued

	Page No.
	<u>WP Sequence No.</u>
Figure 5. Brake Pedal Installation.....	0429-6
Figure 6. Brake Pedal Installation.....	0429-7
Figure 7. Brake Pedal Installation.....	0429-8
Figure 8. Brake Pedal Installation.....	0429-9
BRAKE PEDAL (TREADLE) VALVE REPLACEMENT (M936/A1/A2).....	WP 0430
Figure 1. Cab Air Lines Removal.....	0430-2
Figure 2. Air Lines Removal.....	0430-3
Figure 3. Brake Valve Removal.....	0430-4
Figure 4. Valve Removal.....	0430-5
Figure 5. Brake Valve Installation.....	0430-6
Figure 6. Brake Valve Installation.....	0430-7
Figure 7. Brake Valve Installation.....	0430-8
Figure 8. Brake Pedal Installation.....	0430-9
SPRING PARKING BRAKE VALVE REPAIR.....	WP 0431
Figure 1. Spring Parking Brake Valve Removal.....	0431-3
Figure 2. Spring Parking Brake Valve Adjustment.....	0431-4
Figure 3. Spring Parking Brake Valve Installation.....	0431-5
BRAKE MECHANISM ADJUSTMENTS.....	WP 0432
Figure 1. Front Brake Check and Adjustment.....	0432-3
Figure 2. Rear Brake Check and Adjustment.....	0432-4
Figure 3. Brake Shoe Check.....	0432-5
BRAKE PEDAL REPLACEMENT.....	WP 0433
Figure 1. Brake Pedal Removal.....	0433-2
Figure 2. Brake Pedal Installation.....	0433-3
Figure 3. Brake Pedal Adjustment.....	0433-4
SERVICE BRAKE CHAMBER REPLACEMENT.....	WP 0434
Figure 1. Service Brake Chamber Removal.....	0434-2

TABLE OF CONTENTS - Continued

	Page No.
	<u>WP Sequence No.</u>
Figure 2. Service Brake Chamber Removal.....	0434-3
Figure 3. Service Brake Chamber Removal.....	0434-3
Figure 4. Service Brake Chamber Installation.....	0434-4
Figure 5. Service Brake Chamber Installation.....	0434-5
Figure 6. Service Brake Chamber Installation.....	0434-6
COMBINATION SPRING (EMERGENCY) AND SERVICE BRAKE CHAMBER REPLACEMENT.....	WP 0435
Figure 1. Service Brake Chamber Removal.....	0435-3
Figure 2. Brake Chamber Disassembly.....	0435-4
Figure 3. Brake Chamber Assembly.....	0435-5
Figure 4. Service Brake Chamber Installation.....	0435-6
AIR GOVERNOR REPLACEMENT.....	WP 0436
Figure 1. Air Governor Removal.....	0436-2
Figure 2. Air Governor Installation.....	0436-3
Figure 3. Air Governor Testing.....	0436-4
Figure 4. Air Governor Testing.....	0436-5
Figure 5. Air Governor Adjustment.....	0436-6
AIR RESERVOIR ONE-WAY CHECK VALVE REPLACEMENT.....	WP 0437
Figure 1. Air Reservoir One-Way Check Valve Removal.....	0437-2
Figure 2. Air Reservoir One-Way Check Valve Installation.....	0437-3
BRAKE CHAMBER AIR MANIFOLD TEE REPLACEMENT.....	WP 0438
Figure 1. Brake Chamber Air Manifold Tee Replacement Removal.....	0438-3
Figure 2. Brake Chamber Air Manifold Tee Replacement Installation.....	0438-5
FRONT LIMITING VALVE REPLACEMENT.....	WP 0439
Figure 1. Front Limiting Valve Replacement Removal.....	0439-2
Figure 2. Front Limiting Valve Replacement Installation.....	0439-3
PRIMARY AIR RESERVOIR (SUPPLY TANK) REPLACEMENT.....	WP 0440
Figure 1. Air Reservoir Removal.....	0440-3

TABLE OF CONTENTS - Continued

	Page No.
	<u>WP Sequence No.</u>
Figure 2. Air Reservoir Installation.....	0440-4
SECONDARY AIR RESERVOIR (SUPPLY TANK) REPLACEMENT.....	WP 0441
Figure 1. Secondary Air Reservoir Removal.....	0441-3
Figure 2. Secondary Air Reservoir Installation.....	0441-5
WET AIR RESERVOIR (SUPPLY TANK) AND BRACKET REPLACEMENT.....	WP 0442
Figure 1. Air Tank Removal.....	0442-3
Figure 2. Air Tank Removal.....	0442-5
Figure 3. Air Tank Installation.....	0442-7
Figure 4. Air Line Installation.....	0442-9
WET AIR RESERVOIR (SUPPLY TANK) AND MOUNTING PLATE REPLACEMENT (M936/A1/ A2).....	WP 0443
Figure 1. Wet Air Reservoir Removal.....	0443-3
Figure 2. Wet Air Reservoir Removal.....	0443-5
Figure 3. Wet Air Reservoir Installation.....	0443-7
Figure 4. Wet Air Reservoir Installation.....	0443-8
EMERGENCY SPRING BRAKE (SUPPLY TANK) AIR RESERVOIR REPLACEMENT.....	WP 0444
Figure 1. Air Reservoir Removal.....	0444-3
Figure 2. Air Reservoir Installation.....	0444-4
BRAKE PROPORTIONING VALVE REPLACEMENT.....	WP 0445
Figure 1. Brake Proportioning Valve Removal.....	0445-3
Figure 2. Brake Proportioning Valve Installation.....	0445-5
AIR RESERVOIR DRAIN VALVES REPLACEMENT.....	WP 0446
Figure 1. Air Reservoir Drain Valves Removal.....	0446-3
Figure 2. Air Reservoir Drain Valves Installation.....	0446-4
FAN DRIVE CLUTCH ACTUATOR REPLACEMENT (M939/A1).....	WP 0447
Figure 1. Fan Drive Actuator Removal.....	0447-3
Figure 2. Fan Drive Actuator Installation.....	0447-5
FAN CLUTCH ACTUATOR REPLACEMENT.....	WP 0448

TABLE OF CONTENTS - Continued

	Page No.
	<u>WP Sequence No.</u>
Figure 1. Fan Clutch Actuator Removal.....	0448-2
Figure 2. Fan Clutch Actuator Removal.....	0448-3
Figure 3. Fan Clutch Actuator Installation.....	0448-4
Figure 4. Fan Clutch Actuator Installation.....	0448-5
SPRING BRAKE DASH CONTROL VALVE REPLACEMENT.....	WP 0449
Figure 1. Spring Brake Dash Control Valve Removal.....	0449-3
Figure 2. Spring Brake Dash Control Valve Installation.....	0449-4
AIR COUPLINGS REPLACEMENT.....	WP 0450
Figure 1. Front Air Coupling Removal.....	0450-3
Figure 2. Rear Air Couplings Removal (M923/A1/A2).....	0450-5
Figure 3. Rear Air Couplings Removal (M929/A1/A2, M931/A1/A2, M934/A1/A2, M936/A1/A2).....	0450-7
Figure 4. Front Air Coupling Installation.....	0450-9
Figure 5. Rear Air Couplings Installation (M923/A1/A2).....	0450-11
Figure 6. Rear Air Couplings Installation (M929/A1/A2, M931/A1,A2, M934/A1/A2, M936/A1/A2).....	0450-13
WET RESERVOIR (SUPPLY TANK) SAFETY VALVE REPLACEMENT.....	WP 0451
Figure 1. Safety Valve Removal.....	0451-2
Figure 2. Safety Valve Installation.....	0451-3
ABS ELECTRONIC CONTROL UNIT (ECU) REPLACEMENT.....	WP 0452
Figure 1. ABS Electronic Control Unit Removal.....	0452-2
Figure 2. ABS Electronic Control Unit Installation.....	0452-3
ABS DOUBLE CHECK VALVE NO. 5 REPLACEMENT.....	WP 0453
Figure 1. Double Check Valve No. 5 Removal.....	0453-2
Figure 2. Double Check Valve No. 5 Installation.....	0453-3
ABS DOUBLE CHECK VALVE NO. 6 REPLACEMENT.....	WP 0454
Figure 1. Double Check Valve No. 6 Removal.....	0454-3
Figure 2. Double Check Valve No. 6 Installation.....	0454-4

TABLE OF CONTENTS - Continued

	Page No.
	<u>WP Sequence No.</u>
ABS DOUBLE CHECK VALVE NO. 7 REPLACEMENT.....	WP 0455
Figure 1. Double Check Valve No. 7 Removal.....	0455-3
Figure 2. Double Check Valve No. 7 Installation.....	0455-4
BRAKE LQ-2 VALVE REPLACEMENT.....	WP 0456
Figure 1. Brake LQ-2 Valve Removal.....	0456-3
Figure 2. Brake LQ-2 Valve Installation.....	0456-5
REAR ABS RELAY VALVE REPLACEMENT	WP 0457
Figure 1. Rear ABS Relay Valve Removal.....	0457-3
Figure 2. Rear ABS Relay Valve Installation.....	0457-4
FORWARD ABS RELAY VALVE WITH ECU REPLACEMENT.....	WP 0458
Figure 1. Forward ABS Relay Valve Removal.....	0458-3
Figure 2. Forward ABS Relay Valve Installation.....	0458-5
INVERSION VALVE REPLACEMENT.....	WP 0459
Figure 1. Immersion Valve Removal.....	0459-3
Figure 2. Inversion Valve Installation.....	0459-5
AIR SUPPLY LINE SAFETY VALVE REPLACEMENT.....	WP 0460
Figure 1. Air Supply Line Safety Valve Removal.....	0460-2
Figure 2. Air Supply Line Safety Valve Installation.....	0460-3
GOVERNOR CONTROL AIR LINE REPLACEMENT.....	WP 0461
Figure 1. Governor Control Air Line Removal.....	0461-2
Figure 2. Governor Control Air Line Removal.....	0461-3
Figure 3. Governor Control Air Line Installation.....	0461-4
Figure 4. Governor Control Air Line Installation.....	0461-5
AIR LINE CROSS FITTING REPLACEMENT.....	WP 0462
Figure 1. Air Line Cross Fitting Removal.....	0462-3
Figure 2. Air Line Cross Fitting Installation.....	0462-4
ABS 3-AMP FUSE AND Y LEAD CONNECTOR REPLACEMENT.....	WP 0463

TABLE OF CONTENTS - Continued

	Page No.
	<u>WP Sequence No.</u>
Figure 1. ABS 3-AMP Fuse and Y-Connector Lead Removal.....	0463-2
Figure 2. ABS 3-AMP Fuse and Y-Connector Lead Installation.....	0463-3
ABS 15-AMP FUSE AND JUMPER LEAD REPLACEMENT.....	WP 0464
Figure 1. 15-AMP Fuse and Jumper Lead Removal.....	0464-2
Figure 2. 15-AMP Fuse and Jumper Lead Installation.....	0464-3
ABS GROUND JUMPER LEAD REPLACEMENT.....	WP 0465
Figure 1. ABS Ground Jumper Lead Removal.....	0465-2
Figure 2. ABS Ground Jumper Lead Installation.....	0465-3
ABS INDICATOR LAMP REPLACEMENT.....	WP 0466
Figure 1. ABS Indicator Lamp Removal.....	0466-2
Figure 2. ABS Indicator Lamp Installation.....	0466-3
ABS ECU MAIN WIRING HARNESS REPLACEMENT.....	WP 0467
Figure 1. ABS ECU Main Wiring Harness Removal.....	0467-3
Figure 2. ABS ECU Main Wiring Harness Removal.....	0467-4
Figure 3. ABS ECU Main Wiring Harness Removal.....	0467-5
Figure 4. ABS ECU Main Wiring Harness Installation.....	0467-6
Figure 5. ABS ECU Main Wiring Harness Installation.....	0467-7
Figure 6. ABS ECU Main Wiring Harness Installation.....	0467-9
ABS WHEEL SENSOR AND BRACKET REPLACEMENT.....	WP 0468
Figure 1. ABS Wheel Sensor and Bracket Removal.....	0468-3
Figure 2. ABS Wheel Sensor and Bracket Installation.....	0468-5
REAR ABS RELAY EXCITER RING REPLACEMENT.....	WP 0469
Figure 1. Rear ABS Exciter Ring Removal.....	0469-2
Figure 2. Rear ABS Exciter Ring Installation.....	0469-3
AIR COMPRESSOR AND LINES REPLACEMENT (M939A2).....	WP 0470
Figure 1. Power Steering Pump Removal.....	0470-2
Figure 2. Power Steering Pump Removal.....	0470-3

TABLE OF CONTENTS - Continued

	Page No.
	<u>WP Sequence No.</u>
Figure 3. Power Steering Pump Removal.....	0470-4
Figure 4. Air Compressor Installation.....	0470-5
Figure 5. Air Compressor Installation.....	0470-6
Figure 6. Air Compressor Installation.....	0470-7
AIR COMPRESSOR COOLANT LINES REPLACEMENT (M939A2).....	WP 0471
Figure 1. Air Compressor Coolant Lines Removal.....	0471-3
Figure 2. Air Compressor Coolant Lines Installation.....	0471-4
TRAILER AIRBRAKE HAND CONTROL VALVE REPLACEMENT (M931/A1/A2, M932/A1/A2).....	WP 0472
Figure 1. Trailer Airbrake Hand Control Valve Removal.....	0472-3
Figure 2. Trailer Airbrake Hand Control Valve Installation.....	0472-4
DOUBLE CHECK VALVE NO. 1 REPLACEMENT.....	WP 0473
Figure 1. Double Check Valve No. 1 Removal.....	0473-2
Figure 2. Double Check Valve No. 1 Installation.....	0473-4
DOUBLE CHECK VALVE NO. 2 REPLACEMENT.....	WP 0474
Figure 1. Double Check Valve No. 2 Installation.....	0474-3
Figure 2. Double Check Valve No. 2 Installation.....	0474-5
DOUBLE CHECK VALVE NO. 2 REPLACEMENT (M931/A1/A2, AND M932/A1/A2).....	WP 0475
Figure 1. Double Check Valve No. 2 Removal.....	0475-3
Figure 2. Double Check Valve No. 2 Installation.....	0475-5
DOUBLE CHECK VALVE NO. 5 REPLACEMENT (M931/A1/A2, AND M932/A1/A2).....	WP 0476
Figure 1. Double Check Valve No. 5 Removal.....	0476-3
Figure 2. Double Check Valve No. 5 Installation.....	0476-5
DOUBLE CHECK VALVE NO. 3, NO. 4, AND QUICK-RELEASE VALVE REPLACEMENT.....	WP 0477
Figure 1. Double Check Valve Removal.....	0477-2
Figure 2. Double Check Valve Removal.....	0477-3
Figure 3. Double Check Valve Installation.....	0477-4
Figure 4. Double Check Valve Installation.....	0477-5

TABLE OF CONTENTS - Continued

	Page No.
	<u>WP Sequence No.</u>
EMERGENCY AND TRAILER COUPLING HOSES REPLACEMENT (M931/A1/A2, M932/A1/A2).....	WP 0478
Figure 1. Emergency and Trailer Coupling Hoses Removal.....	0478-3
Figure 2. Emergency and Trailer Coupling Hoses Installation.....	0478-5
FRONT HUB AND DRUM REPLACEMENT (M939/A1).....	WP 0479
Figure 1. Front Hub Drum Removal.....	0479-2
Figure 2. Front Hub and Drum Replacement.....	0479-3
Figure 3. Front Hub and Drum Replacement.....	0479-3
Figure 4. Front Hub Drum Installation.....	0479-5
REAR HUB AND DRUM REPLACEMENT (M939/A1).....	WP 0480
Figure 1. Rear Hub and Drum Removal.....	0480-2
Figure 2. Rear Hub and Drum Removal.....	0480-3
Figure 3. Dust Shield Removal.....	0480-3
Figure 4. Dust Shield Installation.....	0480-5
Figure 5. Rear Hub and Drum Installation.....	0480-6
Figure 6. Rear Hub and Drum Installation.....	0480-7
FRONT HUBS REPLACEMENT.....	WP 0481
Figure 1. Front Hubs Removal.....	0481-3
Figure 2. Front Hubs Repair.....	0481-5
Figure 3. Front Hubs Repair.....	0481-7
Figure 4. Front Hub Installation.....	0481-9
REAR HUBS REPLACEMENT (M939A2).....	WP 0482
Figure 1. Rear Hubs Removal.....	0482-3
Figure 2. Rear Hubs Cleaning and Inspection.....	0482-5
Figure 3. Rear Hubs Cleaning and Inspection.....	0482-7
Figure 4. Rear Hubs Repair.....	0482-9
Figure 5. Rear Hubs Installation.....	0482-11
WHEEL BEARING ADJUSTMENT.....	WP 0483

TABLE OF CONTENTS - Continued

	Page No.
	<u>WP Sequence No.</u>
Figure 1. Front Wheel Bearing Adjustment.....	0483-3
Figure 2. Rear Wheel Bearing Adjustment.....	0483-4
WHEEL AND TIRE ROTATION/REPLACEMENT (M939).....	WP 0484
Figure 1. Wheel and Tire Removal.....	0484-2
Figure 2. Wheel and Tire Inspection.....	0484-3
Figure 3. Wheel and Tire Rotation.....	0484-4
Figure 4. Wheel and Tire Installation.....	0484-5
Figure 5. Wheel and Tire Installation.....	0484-6
Figure 6. Wheel and Tire Installation.....	0484-7
WHEEL AND TIRE ROTATION/REPLACEMENT (M939A1/A2).....	WP 0485
Figure 1. Wheel and Tire Removal.....	0485-2
Figure 2. Wheel and Tire Rotation.....	0485-3
Figure 3. Rear Wheel Installation.....	0485-4
Figure 4. Front Wheel Installation.....	0485-5
WHEEL VALVE FILTER REPLACEMENT (M939A2).....	WP 0486
Figure 1. Wheel Valve Filter Removal.....	0486-3
Figure 2. Wheel Valve Filter Installation.....	0486-4
HUB AIR SEAL LEAK TEST.....	WP 0487
Figure 1. Front Hub Air Seal Test.....	0487-3
Figure 2. Rear Hub Air Seal Test.....	0487-5
REAR AXLE AIR MANIFOLD REPLACEMENT.....	WP 0488
Figure 1. Rear Axle Air Manifold Removal.....	0488-3
Figure 2. Rear Axle Air Manifold Installation.....	0488-5
WHEEL VALVE REPAIR (70 PSI M939A2).....	WP 0489
Figure 1. Wheel Valve Disassembly.....	0489-3
Figure 2. Wheel Valve Assembly.....	0489-5
FRONT WHEEL VALVE MAINTENANCE (M939A2).....	WP 0490

TABLE OF CONTENTS - Continued

	Page No.
	<u>WP Sequence No.</u>
Figure 1. Front Wheel Valve Removal.....	0490-3
Figure 2. Front Wheel Valve Installation.....	0490-5
REAR WHEEL VALVE REPAIR (M939A2).....	WP 0491
Figure 1. Rear Wheel Valve Removal.....	0491-3
Figure 2. Rear Wheel Valve Installation.....	0491-5
DRAG LINK REPLACEMENT.....	WP 0492
Figure 1. Drag Link Removal.....	0492-2
Figure 2. Drag Link Installation.....	0492-3
TIE ROD AND TOE-IN CHECK/REPAIR.....	WP 0493
Figure 1. Toe-In Check.....	0493-3
Figure 2. Toe-In Adjustment.....	0493-4
Figure 3. Tie Rod Removal.....	0493-5
Figure 4. Tie Rod Installation.....	0493-6
UPPER AND LOWER STEERING COLUMN REPAIR.....	WP 0494
Figure 1. Steering Column Removal.....	0494-3
Figure 2. Upper and Lower Steering Column Repair.....	0494-5
Figure 3. Upper and Lower Steering Column Reassembly.....	0494-7
Figure 4. Steering Column Installation.....	0494-9
STEERING WHEEL REPLACEMENT.....	WP 0495
Figure 1. Steering Wheel Removal.....	0495-2
Figure 2. Steering Wheel Installation.....	0495-3
PITMAN ARM REPLACEMENT (ROSS).....	WP 0496
Figure 1. Pitman Arm Removal.....	0496-1
Figure 2. Pitman Arm Installation.....	0496-2
STEERING STOP ADJUSTMENT.....	WP 0497
Figure 1. Steering Stop Adjustment.....	0497-3
STEERING GEAR STONE SHIELD REPLACEMENT.....	WP 0498

TABLE OF CONTENTS - Continued

	Page No.
	<u>WP Sequence No.</u>
Figure 1. Steering Gear Stone Shield Removal.....	0498-1
Figure 2. Steering Gear Stone Shield Installation.....	0498-2
STEERING GEAR AND MOUNTING BRACKET REPLACEMENT (ROSS).....	WP 0499
Figure 1. Steering Gear Input Shaft Removal.....	0499-2
Figure 2. Pitman Arm Removal.....	0499-3
Figure 3. Power Steering Lines Removal.....	0499-4
Figure 4. Steering Geer (Ross) and Mounting Bracket Removal.....	0499-5
Figure 5. Steering Gear Installation.....	0499-6
Figure 6. Power Steering Lines Installation.....	0499-7
Figure 7. Pitman Arm Installation.....	0499-8
Figure 8. Steering Geer (Ross) Installation.....	0499-9
STEERING GEAR (SHEPPARD) AND MOUNTING BRACKET REPLACEMENT (M939A2 ONLY).....	WP 0500
Figure 1. Steering Gear (Sheppard) Removal (M939A2).....	0500-3
Figure 2. Steering Gear (Sheppard) and Mounting Bracket Installation (M939A2).....	0500-5
Figure 3. Steering Gear (Sheppard) and Mounting Bracket Installation (M939A2).....	0500-7
Figure 4. Steering Gear (Sheppard) Assembly (M939A2).....	0500-8
Figure 5. Steering Gear Installation (M939A2).....	0500-9
PITMAN ARM REPLACEMENT (SHEPPARD).....	WP 0501
Figure 1. Pitman Arm Removal.....	0501-2
Figure 2. Pitman Arm Installation.....	0501-3
POWER STEERING PUMP FILTER AND RESERVOIR REPLACEMENT (M939A2).....	WP 0502
Figure 1. Power Steering Pump Filter and Reservoir Removal.....	0502-3
Figure 2. Power Steering Pump Filter and Reservoir Installation.....	0502-5
POWER STEERING PUMP REPLACEMENT (M939/A1).....	WP 0503
Figure 1. Power Steering Pump Removal.....	0503-3
Figure 2. Power Steering Pump Disassembly.....	0503-4
Figure 3. Power Steering Pump Disassembly.....	0503-5

TABLE OF CONTENTS - Continued

	Page No.
	<u>WP Sequence No.</u>
Figure 4. Power Steering Pump Assembly.....	0503-6
Figure 5. Power Steering Pump Assembly.....	0503-7
Figure 6. Power Steering Pump Installation.....	0503-8
STEERING PUMP DRIVEBELTS REPLACEMENT (M939/A1).....	WP 0504
Figure 1. Steering Pump Drivebelts Removal.....	0504-2
Figure 2. Steering Pump Drivebelts Installation.....	0504-3
Figure 3. Steering Pump Drivebelts Adjustment.....	0504-4
POWER STEERING PUMP PRESSURE AND RETURN HOSES REPLACEMENT (ROSS) (M939/A1).....	WP 0505
Figure 1. Power Steering Pump Removal.....	0505-3
Figure 2. Power Steering Pump Installation.....	0505-5
POWER STEERING PUMP PRESSURE AND RETURN HOSES REPLACEMENT (SHEPPARD) (M939/A1).....	WP 0506
Figure 1. Power Steering Pump Pressure and Return Hose Removal.....	0506-3
Figure 2. Power Steering Pump Pressure and Return Hose Installation.....	0506-5
STEERING ASSIST CYLINDER HOSES REPLACEMENT.....	WP 0507
Figure 1. Steering Assist Cylinder Hoses Replacement.....	0507-3
STEERING GEAR-TO-ASSIST CYLINDER PRESSURE LINES REPLACEMENT.....	WP 0508
Figure 1. Pressure Lines Removal.....	0508-3
Figure 2. Pressure Lines Installation.....	0508-5
POWER STEERING GEAR STOP ADJUSTMENT (ON-VEHICLE).....	WP 0509
Figure 1. Steering Wheel.....	0509-2
Figure 2. Sector Shaft Adjustment (On-Vehicle).....	0509-3
Figure 3. Worm Shaft Adjustment (On-Vehicle).....	0509-4
Figure 4. Steering Wheel.....	0509-5
STEERING ASSIST CYLINDER REPLACEMENT.....	WP 0510
Figure 1. Steering Assist Cylinder Removal.....	0510-3
Figure 2. Steering Assist Cylinder Disassembly.....	0510-4

TABLE OF CONTENTS - Continued

	Page No.
	<u>WP Sequence No.</u>
Figure 3. Steering Assist Cylinder Assembly.....	0510-5
Figure 4. Steering Assist Cylinder Installation.....	0510-6
Figure 5. Steering Assist Cylinder Travel Adjustment.....	0510-7
STEERING ASSIST CYLINDER STONE SHIELD REPLACEMENT.....	WP 0511
Figure 1. Steering Assist Cylinder Stone Shield Removal.....	0511-2
Figure 2. Steering Assist Cylinder Stone Shield Installation.....	0511-3
FRONT AND REAR LIFTING SHACKLE AND BRACKET REPLACEMENT.....	WP 0512
Figure 1. Shackle and Bracket Removal.....	0512-3
Figure 2. Shackle and Bracket Installation.....	0512-4
REAR CAB IMPROVED CROSSMEMBER REPLACEMENT.....	WP 0513
Figure 1. Muffler and Spare Tire Carrier Removal.....	0513-2
Figure 2. Spare Tire Carrier Removal.....	0513-3
Figure 3. Air Lines and Fuel Tank Removal.....	0513-4
Figure 4. Primary Air Tank Removal.....	0513-5
Figure 5. Fuel Line Clamps Removal.....	0513-6
Figure 6. Fuel Lines and Clamps Removal.....	0513-7
Figure 7. Bracket Removal.....	0513-8
Figure 8. Crossmember and Exhaust Support Bracket Removal.....	0513-9
Figure 9. Rear Mount Cab Removal.....	0513-10
Figure 10. Hole Location Removal.....	0513-11
Figure 11. Raising the Cab Removal.....	0513-12
Figure 12. Crossmember Removal.....	0513-13
Figure 13. Cross Shaft Lever and Cross Shaft Removal.....	0513-14
Figure 14. Cross Shaft Lever and Cross Shaft Installation.....	0513-15
Figure 15. Crossmember Assembly and Plates Installation.....	0513-16
Figure 16. Crossmember Installation.....	0513-17
Figure 17. Rear Cab Mount (Side Profile) Installation.....	0513-18

TABLE OF CONTENTS - Continued

	Page No.
	<u>WP Sequence No.</u>
Figure 18. Bracket Installation.....	0513-19
Figure 19. Primary Air Tank Installation.....	0513-20
Figure 20. Spare Tire Carrier Installation.....	0513-21
FRONT AND REAR FIELD CHOCK ANCHORS REPLACEMENT (M936/A1 Wrecker).....	WP 0514
Figure 1. Front and Rear Field Chock Anchors Removal (M936/A1).....	0514-2
Figure 2. Front and Rear Field Chock Anchors Installation (M936/A1).....	0514-3
BUMPERETTE REPLACEMENT.....	WP 0515
Figure 1. Bumperette Removal.....	0515-1
Figure 2. Bumperette Installation.....	0515-2
FRONT BUMPER AND PLATES REPLACEMENT.....	WP 0516
Figure 1. Front Bumper and Plates Removal.....	0516-3
Figure 2. Front Bumper and Plates Installation.....	0516-5
VEHICLE TIEDOWN COMPONENT REPLACEMENT.....	WP 0517
Figure 1. Vehicle Tiedown Component Removal.....	0517-2
Figure 2. Vehicle Tiedown Component Installation.....	0517-3
PINTLE HOOK REPAIR.....	WP 0518
Figure 1. Pintle Hook Removal.....	0518-1
Figure 2. Pintle Hook Disassembly.....	0518-2
Figure 3. Pintle Hook Cleaning and Inspection.....	0518-3
Figure 4. Pintle Hook Assembly.....	0518-4
Figure 5. Pintle Hook Installation.....	0518-5
VAN DAVIT CHAIN AND WIRE ROPE REPLACEMENT.....	WP 0519
Figure 1. Van Davit Chain and Wire Rope Removal.....	0519-2
Figure 2. Van Davit Chain and Wire Rope Removal.....	0519-3
Figure 3. Van Davit Chain and Wire Rope Removal.....	0519-4
Figure 4. Van Davit Chain and Wire Rope Installation.....	0519-5
Figure 5. Van Davit Chain and Wire Rope Installation.....	0519-6

TABLE OF CONTENTS - Continued

	Page No.
	<u>WP Sequence No.</u>
Figure 6. Van Davit Chain and Wire Rope Installation.....	0519-7
VAN SWING DAVIT AND PULLEY REPLACEMENT.....	WP 0520
Figure 1. Van Swing Davit and Pulley Removal.....	0520-3
Figure 2. Van Swing Davit and Pulley Installation.....	0520-5
VAN DAVIT WINCH REPLACEMENT (M934A1/A2).....	WP 0521
Figure 1. Van Davit Winch Removal.....	0521-2
Figure 2. Van Davit Winch Installation.....	0521-3
TRACTOR SPARE TIRE CARRIER REPLACEMENT (M931 AND M932).....	WP 0522
Figure 1. Tractor Spare Tire Carrier Removal (M931 and M932).....	0522-3
Figure 2. Tractor Spare Tire Carrier Installation (M931 and M932).....	0522-5
TRACTOR SPARE TIRE CARRIER AND TOOLBOX REPLACEMENT (M931A1/A2 and M932A1/A2).....	WP 0523
Figure 1. Spare Tire Carrier and Toolbox Removal.....	0523-3
Figure 2. Spare Tire Carrier and Toolbox Removal.....	0523-4
Figure 3. Spare Tire Carrier and Toolbox Removal.....	0523-5
Figure 4. Spare Tire Carrier and Toolbox Installation.....	0523-6
Figure 5. Spare Tire Carrier and Toolbox Installation.....	0523-7
Figure 6. Spare Tire Carrier and Toolbox Installation.....	0523-9
DUMP AND TRACTOR SPARE TIRE CARRIER ACCESS STEP REPLACEMENT.....	WP 0524
Figure 1. Dump and Tractor Spare Tire Carrier Access Step Removal.....	0524-3
Figure 2. Dump and Tractor Spare Tire Carrier Access Step Installation.....	0524-5
DUMP AND VAN SPARE TIRE CARRIER REPLACEMENT (M929, M930, M934).....	WP 0525
Figure 1. Spare Tire Carrier Removal.....	0525-2
Figure 2. Spare Tire Carrier Installation.....	0525-3
DUMP AND VAN SPARE TIRE CARRIER REPLACEMENT (M929A1/A2, M930A1/A2, M934A1/ A2).....	WP 0526
Figure 1. Dump Spare Tire Carrier Removal.....	0526-2
Figure 2. Dump Spare Tire Carrier Removal.....	0526-3

TABLE OF CONTENTS - Continued

	Page No.
	<u>WP Sequence No.</u>
Figure 3. Dump Spare Tire Carrier Installation.....	0526-4
Figure 4. Dump Spare Tire Carrier Installation.....	0526-5
Figure 5. Van Spare Tire Carrier Removal.....	0526-7
Figure 6. Van Spare Tire Carrier Installation.....	0526-9
CARGO SPARE TIRE CARRIER REPLACEMENT (M923, M925, M927, M928).....	WP 0527
Figure 1. Cargo Spare Tire Carrier Removal.....	0527-2
Figure 2. Cargo Spare Tire Carrier Installation.....	0527-3
CARGO SPARE TIRE CARRIER REPLACEMENT (M923A1/A2, M925A1/A2, M927A1/A2, M928A1/A2).....	WP 0528
Figure 1. Cargo Spare Tire Carrier Removal.....	0528-3
Figure 2. Cargo Spare Tire Carrier Installation.....	0528-5
CARGO SPARE TIRE CARRIER ACCESS STEP REPLACEMENT.....	WP 0529
Figure 1. Cargo Spare Tire Carrier Access Step Removal.....	0529-2
Figure 2. Cargo Spare Tire Carrier Access Step Installation.....	0529-3
TRACTOR FIFTH WHEEL (DAYTON/WALTER) REMOVAL.....	WP 0530
Figure 1. Fifth Wheel Removal.....	0530-3
FIFTH WHEEL APPROACH PLATES REPLACEMENT.....	WP 0531
Figure 1. Fifth Wheel Approach Plates Removal.....	0531-1
Figure 2. Fifth Wheel Approach Plates Installation.....	0531-2
FIFTH WHEEL DECK PLATE REPLACEMENT.....	WP 0532
Figure 1. Fifth Wheel Deck Plate Removal.....	0532-1
Figure 2. Fifth Wheel Deck Plate Installation.....	0532-2
FIFTH WHEEL SPACERS REPLACEMENT.....	WP 0533
Figure 1. Fifth Wheel Spacers Removal.....	0533-1
Figure 2. Fifth Wheel Spacers Installation.....	0533-2
FRONT SPRING AND MAIN LEAF REPAIR.....	WP 0534
Figure 1. Steering Cylinder Removal.....	0534-3
Figure 2. Steering Cylinder Removal.....	0534-4

TABLE OF CONTENTS - Continued

	Page No.
	<u>WP Sequence No.</u>
Figure 3. Spring Assembly Removal.....	0534-5
Figure 4. Front Spring Main Leaf Removal.....	0534-6
Figure 5. Front Spring Main Leaf Installation.....	0534-7
Figure 6. Front Spring Installation.....	0534-9
Figure 7. Steering Cylinder Installation.....	0534-10
FRONT SPRING SHACKLE AND SHACKLE HANGER REPLACEMENT.....	WP 0535
Figure 1. Front Spring Shackle and Shackle Hanger Removal.....	0535-2
Figure 2. Front Spring Shackle and Shackle Hanger Installation.....	0535-3
FRONT SPRING BUSHING REPLACEMENT.....	WP 0536
Figure 1. Front Spring Bushing Inspection.....	0536-1
Figure 2. Front Spring Bushing Removal.....	0536-2
Figure 3. Front Spring Bushing Installation.....	0536-3
FRONT SPRING BUMPER REPLACEMENT.....	WP 0537
Figure 1. Front Spring Bumper Removal.....	0537-1
Figure 2. Front Spring Bumper Installation.....	0537-2
REAR SPRING BUMPER REPLACEMENT.....	WP 0538
Figure 1. Rear Spring Bumper Removal.....	0538-1
Figure 2. Rear Spring Bumper Installation.....	0538-2
REAR SPRING REPAIR.....	WP 0539
Figure 1. Rear Spring Removal.....	0539-1
Figure 2. Rear Spring Removal.....	0539-3
Figure 3. Rear Spring Removal.....	0539-4
Figure 4. Rear Spring Removal.....	0539-5
Figure 5. Rear Spring Removal.....	0539-6
Figure 6. Rear Spring Removal.....	0539-7
Figure 7. Rear Spring Installation.....	0539-8
Figure 8. Rear Spring Installation.....	0539-8

TABLE OF CONTENTS - Continued

	Page No.
	<u>WP Sequence No.</u>
Figure 9. Rear Spring Installation.....	0539-9
Figure 10. Rear Spring Installation.....	0539-9
Figure 11. Rear Spring Installation.....	0539-10
Figure 12. Rear Spring Installation.....	0539-10
Figure 13. Rear Spring Installation.....	0539-11
REAR SPRING SEAT REPAIR.....	WP 0540
Figure 1. Rear Spring Seat Removal.....	0540-2
Figure 2. Rear Spring Seat Removal.....	0540-3
Figure 3. Rear Spring Seat Lubrication.....	0540-4
Figure 4. Rear Spring Seat Installation.....	0540-5
Figure 5. Rear Spring Seat Installation.....	0540-7
Figure 6. Rear Spring Seat Adjustment.....	0540-8
REAR AXLES SPRING SEAT WEAR PADS AND UPPER BRACKET REPLACEMENT.....	WP 0541
Figure 1. Rear Axle Spring Seat Wear Pads and Upper Bracket Removal.....	0541-2
Figure 2. Rear Axle Spring Seat Wear Pads and Upper Bracket Removal.....	0541-3
Figure 3. Rear Axle Spring Seat Wear Pads and Upper Bracket Installation.....	0541-4
Figure 4. Rear Axle Spring Seat Wear Pads and Upper Bracket Installation.....	0541-5
CROSS TUBE REPLACEMENT.....	WP 0542
Figure 1. Cross Tube Removal.....	0542-2
Figure 2. Cross Tube Installation.....	0542-3
SHOCK ABSORBER AND MOUNTING PINS REPLACEMENT.....	WP 0543
Figure 1. Shock Absorber and Mounting Pins Removal.....	0543-1
Figure 2. Shock Absorber and Mounting Pins Removal.....	0543-2
Figure 3. Shock Absorber and Mounting Pins Installation.....	0543-3
Figure 4. Shock Absorber and Mounting Pins Installation.....	0543-4
UPPER AND LOWER TORQUE ROD REPLACEMENT.....	WP 0544
Figure 1. Upper Torque Rod Removal.....	0544-2

TABLE OF CONTENTS - Continued

	Page No.
	<u>WP Sequence No.</u>
Figure 2. Upper Torque Rod Removal.....	0544-3
Figure 3. Upper Torque Rod Removal.....	0544-4
Figure 4. Lower Torque Rod Removal.....	0544-5
Figure 5. Preload for Upper Torque Rod.....	0544-8
Figure 6. Upper Torque Rod Installation.....	0544-9
Figure 7. Lower Torque Rod Installation.....	0544-10
CAB DOOR REPLACEMENT.....	WP 0545
Figure 1. Cab Door Removal.....	0545-2
Figure 2. Cab Door Installation.....	0545-3
OUTSIDE DOOR HANDLE REPLACEMENT.....	WP 0546
Figure 1. Outside Door Handles Removal.....	0546-2
Figure 2. Outside Door Handles Installation.....	0546-3
CAB DOOR DOVETAIL WEDGE REPLACEMENT.....	WP 0547
Figure 1. Cab Door Dovetail Wedge Removal.....	0547-2
Figure 2. Cab Door Dovetail Wedge Installation.....	0547-3
CAB DOOR DOVETAIL REPLACEMENT.....	WP 0548
Figure 1. Cab Door Dovetail Removal.....	0548-1
Figure 2. Cab Door Dovetail Installation.....	0548-2
CAB DOOR WEATHER SEAL REPLACEMENT.....	WP 0549
Figure 1. Cab Door Weather Seal Removal.....	0549-1
Figure 2. Cab Door Weather Seal Installation.....	0549-2
CAB DOOR INSPECTION HOLE COVER REPLACEMENT.....	WP 0550
Figure 1. Cab Door Inspection Hole Cover Removal.....	0550-1
Figure 2. Cab Door Inspection Hole Cover Installation.....	0550-2
CAB DOOR LOCK REPLACEMENT.....	WP 0551
Figure 1. Cab Door Lock Removal.....	0551-2
Figure 2. Cab Door Lock Installation.....	0551-3

TABLE OF CONTENTS - Continued

	Page No.
	<u>WP Sequence No.</u>
CAB DOOR GLASS REPLACEMENT.....	WP 0552
Figure 1. Cab Door Glass Removal.....	0552-3
Figure 2. Cab Door Glass Disassembly.....	0552-5
Figure 3. Cab Door Glass Assembly.....	0552-6
Figure 4. Cab Door Glass Installation.....	0552-7
WINDOW WEATHER STRIPPING (CAB DOOR) REPLACEMENT.....	WP 0553
Figure 1. Window Weather Stripping Removal.....	0553-1
Figure 2. Window Weather Stripping Installation.....	0553-2
Index	
Volume 4	
Chapter 9 - MAINTENANCE INSTRUCTIONS	
WINDOW BLACKOUT PANEL REPLACEMENT.....	WP 0554
Figure 1. Window Blackout Panel Removal.....	0554-2
Figure 2. Window Blackout Panel Installation.....	0554-3
CAB DOOR CHECK ROD REPLACEMENT.....	WP 0555
Figure 1. Cab Door Check Rod Removal.....	0555-2
Figure 2. Cab Door Check Rod Installation.....	0555-3
CAB DOOR HINGE REPLACEMENT.....	WP 0556
Figure 1. Cab Door Hinge Removal.....	0556-2
Figure 2. Cab Door Hinge Installation.....	0556-3
CAB DOOR CATCH REPLACEMENT.....	WP 0557
Figure 1. Cab Door Catch Removal.....	0557-1
Figure 2. Cab Door Catch Installation.....	0557-2
HOOD LATCH AND BRACKET REPLACEMENT.....	WP 0558
Figure 1. Hood Latch & Bracket Removal.....	0558-3
Figure 2. Hood Latch & Bracket Installation.....	0558-5
HOOD SUPPORT BAR BRACKET, CROSSMEMBER, HINGES, AND TORSION BARS REPLACEMENT.....	WP 0559

TABLE OF CONTENTS - Continued

	Page No.
	<u>WP Sequence No.</u>
Figure 1. Hood Support Bar and Bracket Removal.....	0559-3
Figure 2. Hood Support Bar and Bracket Installation.....	0559-4
Figure 3. Hood Retaining Bracket Replacement.....	0559-5
Figure 4. Hood Crossmember Bracket Removal.....	0559-6
Figure 5. Hood Crossmember Bracket Cleaning and Inspection.....	0559-7
Figure 6. Hood Crossmember Bracket Installation.....	0559-9
Figure 7. Hood Hinge Removal.....	0559-11
Figure 8. Hood Hinge Installation.....	0559-13
Figure 9. Torsion Bars and Crossmembers Removal.....	0559-15
Figure 10. Torsion Bars and Crossmembers Installation.....	0559-17
HOOD STOP CABLES REPLACEMENT.....	WP 0560
Figure 1. Hood Stop Cables Removal.....	0560-2
Figure 2. Hood Stop Cables Installation.....	0560-3
HOOD GRAB HANDLE REPLACEMENT.....	WP 0561
Figure 1. Hood Grab Handle Removal.....	0561-1
Figure 2. Hood Grab Handle Installation.....	0561-2
RADIATOR BAFFLES, SEALS, AND PLATES REPLACEMENT.....	WP 0562
Figure 1. Radiator Baffles, Seals, and Plates Removal.....	0562-2
Figure 2. Radiator Baffles, Seals, and Plates Installation.....	0562-3
CAB HOOD STOP BRACKET REPLACEMENT.....	WP 0563
Figure 1. Cab Hood Stop Bracket Removal.....	0563-1
Figure 2. Cab Hood Stop Bracket Installation.....	0563-2
HOOD BUMPER REPLACEMENT.....	WP 0564
Figure 1. Hood Bumper Removal.....	0564-1
Figure 2. Hood Bumper Installation.....	0564-2
ENGINE HOOD REPLACEMENT.....	WP 0565
Figure 1. Engine Hood Removal.....	0565-3

TABLE OF CONTENTS - Continued

	Page No.
	<u>WP Sequence No.</u>
Figure 2. Engine Hood Removal.....	0565-5
Figure 3. Engine Hood Installation.....	0565-7
Figure 4. Engine Hood Installation.....	0565-9
Figure 5. Engine Hood Adjustment.....	0565-11
WINDSHIELD STOP BRACKET AND LATCH REPLACEMENT.....	WP 0566
Figure 1. Windshield Stop Bracket and Latch Removal.....	0566-1
Figure 2. Windshield Stop Bracket and Latch Installation.....	0566-2
ENGINE ACCESS COVER (IN-CAB) REPLACEMENT.....	WP 0567
Figure 1. Engine Access Cover (In-Cab) Removal.....	0567-3
Figure 2. Engine Access Cover (In-Cab) Installation.....	0567-5
FRONT CAB MOUNT REPLACEMENT.....	WP 0568
Figure 1. Front Cab Mount Removal.....	0568-3
Figure 2. Front Cab Mount Installation.....	0568-5
REAR CAB MOUNT REPLACEMENT.....	WP 0569
Figure 1. Rear Cab Mount Removal.....	0569-2
Figure 2. Rear Cab Mount Installation.....	0569-3
CAB GRAB HANDLE REPLACEMENT.....	WP 0570
Figure 1. Cab Grab Handle Removal.....	0570-2
Figure 2. Cab Grab Handle Installation.....	0570-3
VENT DOOR WEATHER SEAL REPLACEMENT.....	WP 0571
Figure 1. Vent Door Weather Seal Removal.....	0571-2
Figure 2. Vent Door Weather Seal Installation.....	0571-3
CAB COWL VENT SCREEN AND DOOR REPLACEMENT.....	WP 0572
Figure 1. Cab Cowl Vent Screen & Door Removal.....	0572-2
Figure 2. Cab Cowl Vent Screen & Door Installation.....	0572-3
FRONT FENDERS REPLACEMENT.....	WP 0573
Figure 1. Front Fender Removal.....	0573-2

TABLE OF CONTENTS - Continued

	Page No.
	<u>WP Sequence No.</u>
Figure 2. Front Fender Installation.....	0573-3
FRONT FENDER EXTENSION REPLACEMENT.....	WP 0574
Figure 1. Front Fender Extension Removal.....	0574-2
Figure 2. Front Fender Extension Installation.....	0574-3
FENDER SPLASH SHIELD REPLACEMENT.....	WP 0575
Figure 1. Fender Splash Shield Removal.....	0575-2
Figure 2. Fender Splash Shield Installation.....	0575-3
RADIATOR BRUSHGUARD REPLACEMENT.....	WP 0576
Figure 1. Radiator Brushguard Removal.....	0576-3
Figure 2. Radiator Brushguard Removal.....	0576-4
Figure 3. Radiator Brushguard Removal.....	0576-5
Figure 4. Radiator Brushguard Installation.....	0576-6
Figure 5. Radiator Brushguard Installation.....	0576-7
Figure 6. Radiator Brushguard Installation.....	0576-9
WINDSHIELD AND OUTER FRAME ASSEMBLY REPLACEMENT.....	WP 0577
Figure 1. Windshield and Outer Frame Assembly Removal.....	0577-2
Figure 2. Windshield and Outer Frame Assembly Installation.....	0577-3
WINDSHIELD FRAME ASSEMBLY REPLACEMENT.....	WP 0578
Figure 1. Windshield Frame Removal.....	0578-2
Figure 2. Cab Windshield Disassembly.....	0578-3
Figure 3. Cab Windshield Assembly.....	0578-4
Figure 4. Windshield Frame Installation.....	0578-5
CAB WINDSHIELD HINGE ASSEMBLY REPLACEMENT.....	WP 0579
Figure 1. Cab Windshield Hinge Removal.....	0579-2
Figure 2. Cab Windshield Hinge Installation.....	0579-3
CAB INSULATION REPLACEMENT.....	WP 0580
Figure 1. Cab Insulation Removal.....	0580-2

TABLE OF CONTENTS - Continued

	Page No.
	<u>WP Sequence No.</u>
Figure 2. Cab Insulation Installation.....	0580-3
COMPANION SEAT CUSHION, BACKREST CUSHION, AND FRAME REPLACEMENT.....	WP 0581
Figure 1. Companion Seat Cushion, Backrest Cushion, and Frame Removal.....	0581-1
Figure 2. Companion Seat Cushion, Backrest Cushion, and Frame Removal.....	0581-2
Figure 3. Companion Seat Cushion, Backrest Cushion, and Frame Removal.....	0581-3
Figure 4. Companion Seat Cushion, Backrest Cushion, and Frame Installation.....	0581-4
Figure 5. Companion Seat Cushion, Backrest Cushion, and Frame Installation.....	0581-5
Figure 6. Companion Seat Cushion, Backrest Cushion, and Frame Installation.....	0581-6
DRIVER'S SEAT, FRAME, AND BASE REPLACEMENT.....	WP 0582
Figure 1. Driver's Seat Removal.....	0582-3
Figure 2. Driver's Seat Installation.....	0582-5
Figure 3. Driver's Seat Frame and Base Removal.....	0582-7
Figure 4. Driver's Seat Frame and Base.....	0582-9
Figure 5. Driver's Seat and Frame Installation.....	0582-11
Figure 6. Driver's Seat Frame and Base Installation.....	0582-13
DRIVER'S SEAT CUSHION AND BACKREST CUSHION REPLACEMENT.....	WP 0583
Figure 1. Driver's Seat Cushion and Backrest Cushion Removal.....	0583-1
Figure 2. Driver's Seat Cushion and Backrest Cushion Removal.....	0583-2
Figure 3. Driver's Seat Cushion and Backrest Cushion Installation.....	0583-3
Figure 4. Driver's Seat Cushion and Backrest Cushion Installation.....	0583-4
MAP COMPARTMENT REPLACEMENT.....	WP 0584
Figure 1. Map Compartment Removal.....	0584-2
Figure 2. Map Compartment Installation.....	0584-3
VAN POWER CABLE REEL REPLACEMENT (M934A1/A2).....	WP 0585
Figure 1. Van Power Cable Reel Removal.....	0585-2
Figure 2. Van Power Cable Reel Installation.....	0585-3
TOOLBOX AND STEPS REPLACEMENT.....	WP 0586

TABLE OF CONTENTS - Continued

	Page No.
	<u>WP Sequence No.</u>
Figure 1. Toolbox and Steps Removal.....	0586-3
Figure 2. Toolbox and Steps Installation.....	0586-5
CARGO STOWAGE BOX REPLACEMENT.....	WP 0587
Figure 1. Cargo Stowage Removal.....	0587-2
Figure 2. Cargo Stowage Installation.....	0587-3
CARGO BODY ASSEMBLY REPAIR.....	WP 0588
Figure 1. Front Holddown Brackets.....	0588-2
Figure 2. Intermediate Holddown Brackets.....	0588-3
Figure 3. Cargo Body Removal.....	0588-5
Figure 4. Cargo Body.....	0588-7
Figure 5. Cargo Body.....	0588-9
CARGO TROOP SEAT REPAIR.....	WP 0589
Figure 1. Cargo Troop Seat Removal.....	0589-2
Figure 2. Cargo Troop Seat Installation.....	0589-3
CARGO TAILGATE AND BUMPER REPLACEMENT.....	WP 0590
Figure 1. Cargo Tailgate and Bumper Removal.....	0590-3
Figure 2. Cargo Tailgate and Bumper Installation.....	0590-5
DUMP TAILGATE CONTROL LINKAGE REPLACEMENT.....	WP 0591
Figure 1. Dump Tailgate Control Linkage Removal.....	0591-3
Figure 2. Dump Tailgate Control Linkage Installation.....	0591-5
DUMP TAILGATE ASSEMBLY REPLACEMENT.....	WP 0592
Figure 1. Dump Tailgate Assembly Removal.....	0592-3
Figure 2. Dump Tailgate Assembly Installation.....	0592-5
CARGO BODY FRAME RAIL SILL REPLACEMENT.....	WP 0593
Figure 1. Frame Rail Sill Removal.....	0593-1
Figure 2. Cargo Frame Fabrication.....	0593-2
Figure 3. Cargo Frame Fabrication.....	0593-3

TABLE OF CONTENTS - Continued

	Page No.
	<u>WP Sequence No.</u>
Figure 4. Frame Rail Sill Installation.....	0593-4
DUMP BODY REPAIR.....	WP 0594
Figure 1. Dump Body Removal.....	0594-3
Figure 2. Dump Body Installation.....	0594-5
Figure 3. Dump Body Installation.....	0594-7
DUMP CAB PROTECTOR SHIELD REPAIR.....	WP 0595
Figure 1. Dump Cab Protector Shield Removal.....	0595-2
Figure 2. Dump Cab Protector Shield Removal.....	0595-3
Figure 3. Dump Cab Protector Shield Removal.....	0595-4
Figure 4. Dump Cab Protector Shield Installation.....	0595-5
Figure 5. Dump Cab Protector Shield Installation.....	0595-6
Figure 6. Dump Cab Protector Shield Installation.....	0595-7
CARGO UPPER WHEEL SPLASH GUARD REPLACEMENT.....	WP 0596
Figure 1. Upper Wheel Splash Guard Removal.....	0596-1
Figure 2. Upper Wheel Splash Guard Installation.....	0596-2
SIDE LOCKING PIN RETAINING CLIP REPLACEMENT.....	WP 0597
Figure 1. Side Locking Pin Retaining Clip Removal.....	0597-2
Figure 2. Side Locking Pin Retaining Clip Installation.....	0597-3
TAILGATE PERSONNEL STEP REPLACEMENT.....	WP 0598
Figure 1. Tailgate Personnel Step Replacement.....	0598-2
VAN REAR DOOR AND SIDE DOOR WINDOW REPLACEMENT.....	WP 0599
Figure 1. Van Rear Door and Side Door Window Replacement.....	0599-1
WINDOW BRUSH GUARD REPLACEMENT.....	WP 0600
Figure 1. Window Brush Guard Removal.....	0600-2
Figure 2. Window Brush Guard Installation.....	0600-3
REAR DOOR REPAIR.....	WP 0601
Figure 1. Rear Door Removal.....	0601-2

TABLE OF CONTENTS - Continued

	Page No.
	<u>WP Sequence No.</u>
Figure 2. Rear Door Disassembly.....	0601-3
Figure 3. Rear Door Disassembly.....	0601-4
Figure 4. Rear Door Disassembly.....	0601-5
Figure 5. Rear Door Assembly.....	0601-7
Figure 6. Rear Door Assembly.....	0601-8
Figure 7. Rear Door Assembly.....	0601-9
Figure 8. Rear Door Installation.....	0601-10
VAN SIDE DOORS MAINTENANCE.....	WP 0602
Figure 1. Side Doors Removal.....	0602-3
Figure 2. Side Doors Installation.....	0602-4
VAN HINGED END PANEL REPAIR.....	WP 0603
Figure 1. Hinged End Panel Removal.....	0603-3
Figure 2. Hinged End Panel Disassembly.....	0603-5
Figure 3. Hinged End Panel Assembly.....	0603-7
Figure 4. Hinged End Panel Installation.....	0603-8
VAN HINGED ROOF AND FLOOR COUNTERBALANCE CABLE REPLACEMENT.....	WP 0604
Figure 1. Hinge Roof and Floor Counterbalance Cable Removal.....	0604-2
Figure 2. Hinge Roof and Floor Counterbalance Cable Removal.....	0604-3
Figure 3. Hinge Roof and Floor Counterbalance Cable Installation.....	0604-5
Figure 4. Hinge Roof and Floor Counterbalance Cable Installation.....	0604-6
VAN RETRACTABLE WINDOW REPLACEMENT.....	WP 0605
Figure 1. Retractable Window Removal.....	0605-2
Figure 2. Retractable Window Installation.....	0605-3
Figure 3. Window Glass Removal.....	0605-5
Figure 4. Window Glass Installation.....	0605-7
VAN WINDOW SCREEN REPLACEMENT.....	WP 0606
Figure 1. Window Screen Replacement.....	0606-2

TABLE OF CONTENTS - Continued

	Page No.
	<u>WP Sequence No.</u>
VAN RETRACTABLE WINDOW REGULATOR REPLACEMENT.....	WP 0607
Figure 1. Retractable Window Regulator Removal.....	0607-2
Figure 2. Retractable Window Regulator Installation.....	0607-3
WINDOW REGULATOR AND INSIDE DOOR HANDLE REPLACEMENT.....	WP 0608
Figure 1. Window Removal.....	0608-2
Figure 2. Window Installation.....	0608-3
VAN SIDE PANEL-TO-ROOF TOGGLE CLAMP REPLACEMENT.....	WP 0609
Figure 1. Side Panel-to-Roof Toggle Clamp Removal.....	0609-2
Figure 2. Side Panel-to-Roof Toggle Clamp Installation.....	0609-3
VAN TOGGLE CLAMP ANCHOR POST REPLACEMENT.....	WP 0610
Figure 1. Toggle Clamp Anchor Post Replacement.....	0610-2
VAN SIDE PANEL ROOF SWIVEL HOOK REPLACEMENT.....	WP 0611
Figure 1. Side Panel Roof Swivel Hook Removal.....	0611-2
Figure 2. Side Panel Roof Swivel Hook Installation.....	0611-3
VAN LADDER LOCKING CLAMP REPLACEMENT.....	WP 0612
Figure 1. Ladder Locking Clamp Removal.....	0612-2
Figure 2. Ladder Locking Clamp Installation.....	0612-3
VAN BONNET HANDLE AND CONTROL ROD REPLACEMENT.....	WP 0613
Figure 1. Bonnet Handle and Control Rod Removal.....	0613-2
Figure 2. Bonnet Handle and Control Rod Installation.....	0613-3
VAN DOOR HINGE AND SEAL REPLACEMENT.....	WP 0614
Figure 1. Door Hinge and Seal Removal.....	0614-3
Figure 2. Door Hinge and Seal Installation.....	0614-5
VAN PANEL SEALS REPLACEMENT.....	WP 0615
Figure 1. Panel Seals Removal.....	0615-2
Figure 2. Panel Seals Installation.....	0615-3
VAN DOOR HANDLE AND LOCK REPLACEMENT.....	WP 0616

TABLE OF CONTENTS - Continued

	Page No.
	<u>WP Sequence No.</u>
Figure 1. Door Handle and Lock Removal.....	0616-2
Figure 2. Door Handle and Lock Installation.....	0616-3
VAN DOOR CHECKS REPLACEMENT.....	WP 0617
Figure 1. Door Checks Removal.....	0617-2
Figure 2. Door Checks Installation.....	0617-3
VAN LADDER RACK BUMPERS REPLACEMENT.....	WP 0618
Figure 1. Ladder Rack Bumpers Replacement.....	0618-1
VAN SIDE PANEL RUBBER BUMPERS REPLACEMENT.....	WP 0619
Figure 1. Side Panel Rubber Bumper Replacement.....	0619-1
VAN SIDE PANEL REAR LOCK REPLACEMENT.....	WP 0620
Figure 1. Side Panel Rear Lock Removal.....	0620-2
Figure 2. Side Panel Rear Lock Installation.....	0620-3
VAN SIDE PANEL FRONT LOCK AND HINGED-TYPE ROOF LOCK REPLACEMENT.....	WP 0621
Figure 1. Latch Assembly Removal.....	0621-3
Figure 2. Latch Assembly Installation.....	0621-5
VAN SIDE PANEL EXTERIOR LOCK REPLACEMENT.....	WP 0622
Figure 1. Side Panel Exterior Lock Removal.....	0622-1
Figure 2. Side Panel Exterior Lock Installation.....	0622-2
VAN FLUORESCENT LIGHT TUBE REPLACEMENT.....	WP 0623
Figure 1. Fluorescent Light Tube Removal.....	0623-2
Figure 2. Fluorescent Light Tube Installation.....	0623-3
VAN EMERGENCY/BLACKOUT LIGHT LAMP AND LENS REPLACEMENT.....	WP 0624
Figure 1. Emergency/Blackout Light Lamp and Lens Removal.....	0624-1
Figure 2. Emergency/Blackout Light Lamp and Lens Installation.....	0624-2
VAN BLACKOUT LIGHT SWITCH AND 110-VOLT RECEPTACLE REPLACEMENT.....	WP 0625
Figure 1. Blackout Light Switch and 110-Volt Receptacle Removal.....	0625-2
Figure 2. Blackout Light Switch and 110-Volt Receptacle Installation.....	0625-3

TABLE OF CONTENTS - Continued

	Page No.
	<u>WP Sequence No.</u>
VAN INSIDE TELEPHONE JACK POST REPLACEMENT.....	WP 0626
Figure 1. Inside Telephone Jack Post Removal.....	0626-2
Figure 2. Inside Telephone Jack Post Installation.....	0626-3
VAN OUTSIDE TELEPHONE JACK POST REPLACEMENT.....	WP 0627
Figure 1. Outside Telephone Jack Post Removal.....	0627-3
Figure 2. Outside Telephone Jack Post Installation.....	0627-5
VAN SIDE AND REAR DOOR BLACKOUT LIGHT SWITCH REPLACEMENT.....	WP 0628
Figure 1. Side and Rear Door Blackout Light Switch Removal.....	0628-1
Figure 2. Side and Rear Door Blackout Light Switch Installation.....	0628-2
Figure 3. Side and Rear Door Blackout Light Adjustment.....	0628-3
VAN HINGED ROOF-OPERATED BLACKOUT CIRCUIT PLUNGERS REPLACEMENT.....	WP 0629
Figure 1. Hinged Roof-Operated Blackout Circuit Plungers Removal.....	0629-3
Figure 2. Hinged Roof-Operated Blackout Circuit Plungers Installation.....	0629-4
VAN RETRACTABLE BEAM ASSEMBLY REPLACEMENT.....	WP 0630
Figure 1. Retractable Beam Assembly Removal.....	0630-2
Figure 2. Retractable Beam Assembly Removal.....	0630-3
Figure 3. Retractable Beam Assembly Removal.....	0630-5
Figure 4. Retractable Beam Assembly Removal.....	0630-7
Figure 5. Retractable Beam Assembly Cleaning, Inspection, and Repair.....	0630-9
Figure 6. Retractable Beam Assembly Installation.....	0630-11
Figure 7. Retractable Beam Assembly Installation.....	0630-13
Figure 8. Retractable Beam Assembly Installation.....	0630-14
Figure 9. Retractable Beam Assembly Installation.....	0630-15
VAN HEATER AND EXHAUST REPLACEMENT.....	WP 0631
Figure 1. Van Heater and Exhaust Removal.....	0631-3
Figure 2. Van Heater and Exhaust Installation.....	0631-5
VAN HEATER FUEL PUMP REPLACEMENT (M934/A1/A2).....	WP 0632

TABLE OF CONTENTS - Continued

	Page No.
	<u>WP Sequence No.</u>
Figure 1. Van Heater Fuel Pump Removal (M934A1/A2).....	0632-3
Figure 2. Van Heater Fuel Pump Installation (M934A1/A2).....	0632-5
Figure 3. Van Heater Fuel Pump Removal (M934).....	0632-7
Figure 4. Van Heater Fuel Pump Installation (M934).....	0632-8
AIR CONDITIONER DRAIN TUBE REPLACEMENT.....	WP 0633
Figure 1. Air Conditioner Drain Tube Removal.....	0633-3
Figure 2. Air Conditioner Drain Tube Installation.....	0633-5
HEATER FUEL PUMP WIRING HARNESS REPLACEMENT.....	WP 0634
Figure 1. Heater Fuel Pump Wiring Harness Removal.....	0634-1
Figure 2. Heater Fuel Pump Wiring Harness Removal.....	0634-2
Figure 3. Heater Fuel Pump Wiring Harness Installation.....	0634-3
Figure 4. Heater Fuel Pump Wiring Harness Installation.....	0634-4
RIGHT AND LEFT SIDE BLACKOUT HARNESS REPAIR.....	WP 0635
Figure 1. Blackout Harness.....	0635-3
Figure 2. Blackout Harness.....	0635-4
CIRCUIT BREAKER HARNESS AND CIRCUIT BREAKER REPLACEMENT.....	WP 0636
Figure 1. Circuit Breaker Harness and Circuit Breaker Removal.....	0636-3
Figure 2. Circuit Breaker Harness and Circuit Breaker Installation.....	0636-5
ENTRANCE RECEPTACLE 220V 3-PHASE WIRING HARNESS REPLACEMENT.....	WP 0637
Figure 1. Entrance Receptacle Removal.....	0637-3
Figure 2. Entrance Receptacle Installation.....	0637-5
FLEXIBLE CONVERTER WIRING HARNESS REPLACEMENT.....	WP 0638
Figure 1. Flexible Converter Wiring Harness Removal.....	0638-2
Figure 2. Flexible Converter Wiring Harness Installation.....	0638-3
ELECTRICAL LOAD CENTER BOX REPLACEMENT.....	WP 0639
Figure 1. Load Center Box.....	0639-2
Figure 2. Load Center Box.....	0639-3

TABLE OF CONTENTS - Continued

	Page No.
	<u>WP Sequence No.</u>
Figure 3. Load Center Box.....	0639-4
Figure 4. Load Center Box.....	0639-5
Figure 5. Load Center Box.....	0639-6
Figure 6. Load Center Box.....	0639-7
Figure 7. Load Center Box.....	0639-8
Figure 8. Load Center Box.....	0639-9
Figure 9. Load Center Box.....	0639-10
Figure 10. Load Center Box.....	0639-11
Figure 11. Load Center Box.....	0639-12
Figure 12. Load Center Box.....	0639-13
Figure 13. Load Center Box.....	0639-15
Figure 14. Load Center Box.....	0639-17
Figure 15. Load Center Box.....	0639-19
Figure 16. Load Center Box.....	0639-20
Figure 17. Load Center Box.....	0639-21
Figure 18. Load Center Box.....	0639-22
Figure 19. Load Center Box.....	0639-23
Figure 20. Load Center Box.....	0639-24
Figure 21. Load Center Box.....	0639-25
Figure 22. Load Center Box.....	0639-26
Figure 23. Load Center Box.....	0639-27
Figure 24. Load Center Box.....	0639-28
Figure 25. Load Center Box.....	0639-29
Figure 26. Load Center Box.....	0639-30
Figure 27. Load Center Box.....	0639-31
Figure 28. Load Center Box.....	0639-32
ELECTRICAL BOX REPLACEMENT.....	WP 0640

TABLE OF CONTENTS - Continued

	Page No.
	<u>WP Sequence No.</u>
Figure 1. Electrical Box Removal.....	0640-2
Figure 2. Electrical Box Installation.....	0640-3
ELECTRICAL JUNCTION BOX REPLACEMENT.....	WP 0641
Figure 1. Electrical Junction Box Removal.....	0641-2
Figure 2. Electrical Junction Box Removal.....	0641-3
Figure 3. Electrical Junction Box Installation.....	0641-4
Figure 4. Electrical Junction Box Installation.....	0641-5
400 HZ CONVERTER HARNESS CONDUIT REPLACEMENT.....	WP 0642
Figure 1. Converter Harness Conduit Removal.....	0642-2
Figure 2. Converter Harness Conduit Installation.....	0642-3
HEATER THERMOSTAT AND 10 KW HEATER THERMOSTAT REPLACEMENT.....	WP 0643
Figure 1. Heater Thermostat and 10 KW Heater Thermostat and 10 KW Heater Thermostat Removal.....	0643-1
Figure 2. Heater Thermostat and 10 KW Heater Thermostat and 10 KW Heater Thermostat Removal.....	0643-2
Figure 3. Heater Thermostat and 10 KW Heater Thermostat.....	0643-3
Figure 4. Heater Thermostat and 10 KW Heater Thermostat Installation.....	0643-4
BLACKOUT AND EMERGENCY LIGHT FIXTURES REPLACEMENT.....	WP 0644
Figure 1. Blackout and Emergency Light Fixtures Removal.....	0644-1
Figure 2. Blackout and Emergency Light Fixtures Installation.....	0644-2
AIR CONDITIONER MANUAL STARTER SWITCHES REPLACEMENT.....	WP 0645
Figure 1. Air Conditioner Replacement.....	0645-2
Figure 2. Air Conditioner Switch.....	0645-3
Figure 3. Air Conditioner Switch.....	0645-4
Figure 4. Air Conditioner Switch.....	0645-5
FLUORESCENT LIGHT FIXTURES REPLACEMENT.....	WP 0646
Figure 1. Fluorescent Light.....	0646-2
Figure 2. Fluorescent Light.....	0646-3

TABLE OF CONTENTS - Continued

	Page No.
	<u>WP Sequence No.</u>
400 HZ CONVERTER REPLACEMENT.....	WP 0647
Figure 1. 400 Hz Converter Removal.....	0647-3
Figure 2. 400 Hz Converter Installation.....	0647-5
ELECTRICAL LOAD CENTER CONDUIT REPLACEMENT.....	WP 0648
Figure 1. Electrical Load Center Conduit Removal.....	0648-1
Figure 2. Electrical Load Center Conduit Removal.....	0648-2
Figure 3. Electrical Load Center Conduit Installation.....	0648-3
Figure 4. Electrical Load Center Conduit Installation.....	0648-4
FRONT WALL REGISTERS REPLACEMENT.....	WP 0649
Figure 1. Front Wall Registers Removal.....	0649-1
Figure 2. Front Wall Registers Installation.....	0649-2
BONNET ACCESS DOOR MAINTENANCE.....	WP 0650
Figure 1. Bonnet Access Door Removal.....	0650-3
Figure 2. Bonnet Access Door Disassembly.....	0650-5
Figure 3. Bonnet Access Door Cleaning and Inspection.....	0650-7
Figure 4. Bonnet Access Door Assembly.....	0650-9
Figure 5. Bonnet Access Door Installation.....	0650-10
BONNET DOOR MAINTENANCE.....	WP 0651
Figure 1. Bonnet Door Removal.....	0651-3
Figure 2. Bonnet Door Disassembly.....	0651-5
Figure 3. Bonnet Door Cleaning and Inspection.....	0651-7
Figure 4. Bonnet Door Assembly.....	0651-9
Figure 5. Bonnet Door Installation.....	0651-10
AIR CONDITIONER REPAIR.....	WP 0652
Figure 1. Air Conditioner Removal.....	0652-3
Figure 2. Air Conditioner Removal.....	0652-5
Figure 3. Air Conditioner Installation.....	0652-7

TABLE OF CONTENTS - Continued

	Page No.
	<u>WP Sequence No.</u>
Figure 4. Air Conditioner Installation.....	0652-8
Figure 5. Air Conditioner Installation.....	0652-9
MAIN WIRING HARNESS REPLACEMENT.....	WP 0653
Figure 1. Main Wiring Harness Removal.....	0653-3
Figure 2. Main Wiring Harness Installation.....	0653-5
VAN AIR CONDITIONER WIRING HARNESS REPLACEMENT.....	WP 0654
Figure 1. Van Air Conditioner Wiring Harness Removal.....	0654-3
Figure 2. Van Air Conditioner Wiring Harness Installation.....	0654-5
VAN HEATER WIRING HARNESS REPLACEMENT.....	WP 0655
Figure 1. Van Heater Wiring Harness Removal.....	0655-3
Figure 2. Van Heater Wiring Harness Removal.....	0655-5
Figure 3. Van Heater Wiring Harness Installation.....	0655-7
Figure 4. Van Heater Wiring Harness Installation.....	0655-8
ELECTRIC HEATER (10 KW) WIRING HARNESS REPLACEMENT.....	WP 0656
Figure 1. Electric Heater (10 Kw) Wiring Harness Removal.....	0656-3
Figure 2. Electric Heater (10 Kw) Wiring Harness Installation.....	0656-5
BLACKOUT BYPASS WIRING HARNESS REPAIR.....	WP 0657
Figure 1. Blackout Bypass Wiring Harness Removal.....	0657-3
Figure 2. Blackout Bypass Wiring Harness Installation.....	0657-5
EMERGENCY LAMP WIRING HARNESS REPLACEMENT.....	WP 0658
Figure 1. Emergency Lamp Wiring Harness Removal.....	0658-3
Figure 2. Emergency Wiring Harness Removal.....	0658-5
Figure 3. Emergency Lamp Wiring Harness Installation.....	0658-7
Figure 4. Emergency Lamp Wiring Harness Installation.....	0658-9
Figure 5. Emergency Lamp Wiring Harness Installation.....	0658-11
BLACKOUT AND CLEARANCE LIGHTS WIRING HARNESS REPLACEMENT.....	WP 0659
Figure 1. Blackout and Clearance Lights Wiring Harness Removal.....	0659-3

TABLE OF CONTENTS - Continued

	Page No.
	<u>WP Sequence No.</u>
Figure 2. Blackout and Clearance Lights Wiring Harness Installation.....	0659-5
400 HZ SUPPLY WIRING HARNESS REPLACEMENT.....	WP 0660
Figure 1. 400 Hz Supply Wiring Harness Removal.....	0660-3
Figure 2. 400 Hz Wiring Harness Removal.....	0660-5
Figure 3. 400 Hz Supply Wiring Harness Installation.....	0660-7
Figure 4. 400 Hz Supply Wiring Harness Removal.....	0660-9
BRANCHED 400 HZ RECEPTACLE WIRING HARNESS REPLACEMENT.....	WP 0661
Figure 1. Branched 400 Hz Receptacle Wiring Harness Removal.....	0661-2
Figure 2. Branched 400 Hz Receptacle Wiring Harness Removal.....	0661-3
Figure 3. Branched 400 Hz Receptacle Wiring Harness Installation.....	0661-4
Figure 4. Branched 400 Hz Receptacle Wiring Harness Installation.....	0661-5
TELEPHONE POST WIRING HARNESS REPLACEMENT.....	WP 0662
Figure 1. Telephone Post Wiring Harness Removal.....	0662-2
Figure 2. Telephone Post Wiring Harness Installation.....	0662-3
3 PHASE RECEPTACLE WIRING HARNESS REPLACEMENT.....	WP 0663
Figure 1. 3 Phase Receptacle Wiring Harness Removal.....	0663-3
Figure 2. 3 Phase Receptacle Wiring Harness Removal.....	0663-5
FORWARD DECK PLATE REPLACEMENT.....	WP 0664
Figure 1. Forward Deck Plate Removal.....	0664-2
Figure 2. Forward Deck Plate Installation.....	0664-3
CRANE BODY HOUSING ASSEMBLY COVER REPLACEMENT.....	WP 0665
Figure 1. Crane Body Housing Assembly Cover Removal.....	0665-2
Figure 2. Crane Body Housing Assembly Cover Installation.....	0665-3
WRECKER BODY REPLACEMENT.....	WP 0666
Figure 1. Wrecker Body Removal.....	0666-3
Figure 2. Wrecker Body Installation.....	0666-5
FUEL CAN BRACKET REPLACEMENT.....	WP 0667

TABLE OF CONTENTS - Continued

	Page No.
	<u>WP Sequence No.</u>
Figure 1. Fuel Can Bracket Removal.....	0667-3
Figure 2. Fuel Can Bracket Installation.....	0667-5
FRONT WINCH REPLACEMENT.....	WP 0668
Figure 1. Front Winch Removal.....	0668-3
Figure 2. Front Winch Installation.....	0668-5
REAR WINCH ADJUSTMENT.....	WP 0669
Figure 1. Cable Tensioner Check.....	0669-1
Figure 2. Cable Tensioner Adjustment.....	0669-2
REAR WINCH REPLACEMENT.....	WP 0670
Figure 1. Rear Winch Removal.....	0670-1
Figure 2. Rear Winch Removal.....	0670-2
Figure 3. Rear Winch Removal.....	0670-3
Figure 4. Rear Winch Removal.....	0670-4
Figure 5. Rear Winch Removal.....	0670-5
Figure 6. Rear Winch Installation.....	0670-6
Figure 7. Rear Winch Installation.....	0670-7
Figure 8. Rear Winch Installation.....	0670-8
Figure 9. Rear Winch Installation.....	0670-9
Figure 10. Rear Winch Installation.....	0670-10
WINCH FRAME EXTENSION REPLACEMENT.....	WP 0671
Figure 1. Winch Frame Extension Removal.....	0671-3
Figure 2. Winch Frame Extension Installation.....	0671-5
FRONT WINCH AUTOMATIC BRAKE ADJUSTMENT.....	WP 0672
Figure 1. Front Winch Automatic Brake Testing.....	0672-3
Figure 2. Front Winch Automatic Brake Adjustment.....	0672-4
FRONT WINCH DRAG BRAKE ADJUSTMENT.....	WP 0673
Figure 1. Front Winch Drag Brake Testing.....	0673-1

TABLE OF CONTENTS - Continued

	Page No.
	<u>WP Sequence No.</u>
Figure 2. Front Winch Drag Brake Testing.....	0673-2
Figure 3. Front Winch Drag Brake Adjustment.....	0673-3
FRONT WINCH CABLE CHAIN AND HOOK REPLACEMENT.....	WP 0674
Figure 1. Front Winch Cable Chain and Hook Removal.....	0674-1
Figure 2. Front Winch Cable Chain and Hook Installation.....	0674-2
FRONT WINCH CABLE CLEVIS REPLACEMENT.....	WP 0675
Figure 1. Front Winch Cable Clevis Removal.....	0675-2
Figure 2. Front Winch Cable Clevis Removal.....	0675-3
Figure 3. Front Winch Cable Clevis Installation.....	0675-4
Figure 4. Front Winch Cable Clevis Installation.....	0675-5
Figure 5. Front Winch Cable Clevis Installation.....	0675-5
Figure 6. Front Winch Cable Clevis Installation.....	0675-6
Figure 7. Front Winch Cable Clevis Installation.....	0675-6
Figure 8. Front Winch Cable Clevis Installation.....	0675-7
REAR WINCH ROLLER REPAIR.....	WP 0676
Figure 1. Rear Winch Roller Repair - Side Roller Disassembly.....	0676-2
Figure 2. Rear Winch Roller Repair - Top and Bottom Roller Disassembly.....	0676-3
Figure 3. Rear Winch Roller Cleaning and Inspection.....	0676-5
Figure 4. Rear Winch Roller Repair - Top and Bottom Roller Assembly.....	0676-6
Figure 5. Rear Winch Roller Repair - Side Roller Assembly.....	0676-7
FRONT WINCH CABLE TENSIONER REPAIR.....	WP 0677
Figure 1. Cable Tensioner Removal.....	0677-2
Figure 2. Cable Tensioner Disassembly.....	0677-3
Figure 3. Cable Tensioner Cleaning and Inspection.....	0677-5
Figure 4. Cable Tensioner Assembly.....	0677-6
Figure 5. Cable Tensioner Assembly.....	0677-7
Figure 6. Cable Tensioner.....	0677-8

TABLE OF CONTENTS - Continued

	Page No.
	<u>WP Sequence No.</u>
FRONT AND REAR WINCH LEVEL WIND REPAIR.....	WP 0678
Figure 1. Level Wind Disassembly.....	0678-3
Figure 2. Level Wind Disassembly.....	0678-5
Figure 3. Level Wind Disassembly.....	0678-7
Figure 4. Level Wind Cleaning and Inspection.....	0678-9
Figure 5. Level Wind Cleaning and Inspection.....	0678-10
Figure 6. Level Wind Assembly.....	0678-11
Figure 7. Level Wind Assembly.....	0678-13
Figure 8. Level Wind Assembly.....	0678-15
FRONT WINCH ROLLER ASSEMBLY REPAIR.....	WP 0679
Figure 1. Front Winch Roller Assembly Removal.....	0679-2
Figure 2. Roller Assembly Disassembly.....	0679-3
Figure 3. Roller Assembly Cleaning and Inspection.....	0679-5
Figure 4. Roller Assembly.....	0679-7
Figure 5. Roller Assembly.....	0679-9
Figure 6. Roller Assembly Installation.....	0679-10
FRONT WINCH CONTROL VALVE CABLE REPLACEMENT.....	WP 0680
Figure 1. Front Winch Control Valve Cable Removal.....	0680-2
Figure 2. Winch Control Valve Cable.....	0680-3
Figure 3. Winch Control Valve Cable.....	0680-4
Figure 4. Winch Control Valve Cable Installation.....	0680-5
FRONT AND REAR WINCH CONTROL VALVE REPLACEMENT.....	WP 0681
Figure 1. Front and Rear Winch Control Valve Removal.....	0681-3
Figure 2. Front and Rear Winch Control Valve Installation.....	0681-5
REAR WINCH HYDRAULIC MOTOR REPLACEMENT.....	WP 0682
Figure 1. Rear Winch Hydraulic Motor Removal.....	0682-3
Figure 2. Rear Winch Hydraulic Motor Hoses and Fittings Removal.....	0682-5

TABLE OF CONTENTS - Continued

	Page No.
	<u>WP Sequence No.</u>
Figure 3. Rear Winch Hydraulic Motor Hoses and Fittings Installation.....	0682-7
Figure 4. Rear Winch Hydraulic Motor Installation.....	0682-9
FRONT WINCH HYDRAULIC PUMP REPLACEMENT.....	WP 0683
Figure 1. Front Winch Hydraulic Motor Removal.....	0683-2
Figure 2. Front Winch Hydraulic Motor Installation.....	0683-3
FRONT WINCH CABLE REPLACEMENT.....	WP 0684
Figure 1. Front Winch Cable Removal.....	0684-3
Figure 2. Front Winch Cable Installation.....	0684-5
FRONT WINCH HYDRAULIC HOSE AND TUBE REPLACEMENT.....	WP 0685
Figure 1. Hydraulic Oil Reservoir Hoses Removal.....	0685-3
Figure 2. Front Winch Hydraulic Hoses and Tubes Removal.....	0685-5
Figure 3. Hydraulic Oil Reservoir Hoses Removal.....	0685-6
Figure 4. Hydraulic Oil Reservoir Hoses Removal.....	0685-7
Figure 5. Hydraulic Oil Reservoir Hoses Installation.....	0685-8
Figure 6. Hydraulic Oil Reservoir Hoses Installation.....	0685-9
Figure 7. Front Winch Hydraulic Hoses and Tubes Installation.....	0685-11
Figure 8. Hydraulic Tubes and Hoses Installation.....	0685-13
BOOM REPLACEMENT.....	WP 0686
Figure 1. Boom Removal.....	0686-3
Figure 2. Boom Installation.....	0686-5
INNER BOOM REPLACEMENT.....	WP 0687
Figure 1. Inner Boom Removal.....	0687-3
Figure 2. Inner Boom Installation.....	0687-5
BOOM ROLLER REPAIR.....	WP 0688
Figure 1. Boom Roller Removal.....	0688-3
Figure 2. Boom Roller Installation.....	0688-5
CRANE SWIVEL VALVE REPAIR.....	WP 0689

TABLE OF CONTENTS - Continued

	Page No.
	<u>WP Sequence No.</u>
Figure 1. Wiring Harness Removal.....	0689-3
Figure 2. Crane Swivel Valve Removal.....	0689-5
Figure 3. Crane Swivel Valve Removal.....	0689-7
Figure 4. Crane Swivel Valve Installation.....	0689-9
Figure 5. Crane Swivel Valve Installation.....	0689-11
Figure 6. Wiring Harness Connections.....	0689-13
CRANE HYDRAULIC SWING MOTOR REPLACEMENT.....	WP 0690
Figure 1. Crane Hydraulic Swing Motor Removal.....	0690-3
Figure 2. Crane Hydraulic Swing Motor Installation.....	0690-4
CRANE SWING GEARCASE REPLACEMENT.....	WP 0691
Figure 1. Crane Swing Gearcase Removal.....	0691-2
Figure 2. Crane Swing Gearcase Installation.....	0691-3
TURNTABLE REPAIR.....	WP 0692
Figure 1. Turntable Removal.....	0692-2
Figure 2. Turntable Gear and Bearing Removal.....	0692-3
Figure 3. Turntable Gear and Bearing Installation.....	0692-5
Figure 4. Turntable Installation.....	0692-7
BOOM ELEVATING CYLINDER REPLACEMENT.....	WP 0693
Figure 1. Boom Elevating Cylinder Removal.....	0693-3
Figure 2. Boom Elevating Cylinder Installation.....	0693-5
FRONT WINCH MOTOR REPLACEMENT.....	WP 0694
Figure 1. Front Winch Motor Removal.....	0694-2
Figure 2. Front Winch Motor Removal.....	0694-3
Figure 3. Front Winch Motor Removal.....	0694-4
Figure 4. Front Winch Motor Installation.....	0694-5
Figure 5. Front Winch Motor Installation.....	0694-5
Figure 6. Front Winch Motor Installation.....	0694-6

TABLE OF CONTENTS - Continued

	Page No.
	<u>WP Sequence No.</u>
BOOM EXTENSION CYLINDER REPLACEMENT.....	WP 0695
Figure 1. Boom Extension Cylinder Removal.....	0695-3
Figure 2. Boom Extension Cylinder Installation.....	0695-5
HOIST WINCH REPLACEMENT.....	WP 0696
Figure 1. Hoist Winch Removal.....	0696-3
Figure 2. Hoist Winch Disassembly.....	0696-5
Figure 3. Hoist Winch Disassembly.....	0696-7
Figure 4. Hoist Winch Disassembly.....	0696-9
Figure 5. Hoist Winch Disassembly.....	0696-11
Table 1. Hoist Winch Wear Limits.....	0696-13
Figure 6. Hoist Winch Assembly.....	0696-15
Figure 7. Hoist Winch Assembly.....	0696-17
Figure 8. Hoist Winch Assembly.....	0696-19
Figure 9. Hoist Winch Installation.....	0696-20
HOIST LEVEL WIND REPLACEMENT.....	WP 0697
Figure 1. Hoist Level Wind Removal.....	0697-2
Figure 2. Hoist Level Wind Installation.....	0697-3
CRANE GONDOLA CONTROL VALVE REPAIR.....	WP 0698
Figure 1. Control Valve Cover Removal.....	0698-2
Figure 2. Hose Removal.....	0698-3
Figure 3. Crane Gondola Control Valve Disassembly.....	0698-4
Figure 4. Crane Gondola Control Valve Disassembly.....	0698-5
Figure 5. Crane Gondola Control Valve Disassembly.....	0698-6
Figure 6. Crane Gondola Control Valve Disassembly.....	0698-7
Figure 7. Crane Control Valve Disassembly.....	0698-9
Figure 8. Crane Gondola Control Valve Assembly.....	0698-11
Figure 9. Crane Gondola Control Valve Assembly.....	0698-12

TABLE OF CONTENTS - Continued

	Page No.
	<u>WP Sequence No.</u>
Figure 10. Crane Gondola Control Valve Assembly.....	0698-13
Figure 11. Crane Gondola Control Valve Assembly.....	0698-14
Figure 12. Crane Gondola Control Valve Installation.....	0698-15
Figure 13. Crane Gondola Control Valve Installation.....	0698-16
Figure 14. Crane Gondola Control Valve Installation.....	0698-17
GONDOLA REPAIR.....	WP 0699
Figure 1. Gondola Removal.....	0699-3
Figure 2. Gondola Removal.....	0699-4
Figure 3. Gondola Installation.....	0699-5
Figure 4. Gondola Installation.....	0699-6
HYDRAULIC HOIST WINCH MOTOR AND LINES REPLACEMENT.....	WP 0700
Figure 1. Hydraulic Hoist Winch Motor and Lines Removal.....	0700-3
Figure 2. Hydraulic Hoist Winch Motor and Lines Installation.....	0700-4
WINCH HYDRAULIC OIL RESERVOIR REPLACEMENT.....	WP 0701
Figure 1. Winch Hydraulic Oil Reservoir Removal.....	0701-3
Figure 2. Winch Hydraulic Oil Reservoir Removal.....	0701-4
Figure 3. Winch Hydraulic Oil Reservoir Installation.....	0701-5
Figure 4. Winch Hydraulic Oil Reservoir Installation.....	0701-6
TRACTOR WINCH HYDRAULIC OIL RESERVOIR REPLACEMENT (M932/A1/A2).....	WP 0702
Figure 1. Tractor Winch Hydraulic Oil Reservoir Removal.....	0702-3
Figure 2. Tractor Winch Hydraulic Oil Reservoir Removal.....	0702-5
Figure 3. Tractor Winch Hydraulic Oil Reservoir Removal.....	0702-7
Figure 4. Tractor Winch Hydraulic Oil Reservoir Installation.....	0702-9
Figure 5. Tractor Winch Hydraulic Oil Reservoir Installation.....	0702-10
Figure 6. Tractor Winch Hydraulic Oil Reservoir Installation.....	0702-11
WRECKER HYDRAULIC OIL RESERVOIR, BRACKETS AND STRAPS REPAIR.....	WP 0703
Figure 1. Hydraulic Oil Reservoir Removal.....	0703-3

TABLE OF CONTENTS - Continued

	Page No.
	<u>WP Sequence No.</u>
Figure 2. Hydraulic Oil Reservoir Brackets and Straps Removal.....	0703-4
Figure 3. Hydraulic Oil Reservoir Disassembly.....	0703-5
Figure 4. Hydraulic Oil Reservoir, Brackets and Straps Assembly.....	0703-7
Figure 5. Hydraulic Oil Reservoir Brackets and Straps Installation.....	0703-8
Figure 6. Hydraulic Oil Reservoir Installation.....	0703-9
WINCH HYDRAULIC OIL RESERVOIR FILTER REPLACEMENT.....	WP 0704
Figure 1. Winch Hydraulic Oil Reservoir Filter Removal.....	0704-3
Figure 2. Winch Hydraulic Oil Reservoir Filter Installation.....	0704-5
PRESSURE RELIEF VALVE ADJUSTMENT.....	WP 0705
Figure 1. Pressure Relief Valve Testing.....	0705-2
Figure 2. Pressure Relief Valve Adjustment.....	0705-3
SNUBBER VALVE ASSEMBLY REPLACEMENT.....	WP 0706
Figure 1. Snubber Valve Assembly Removal.....	0706-3
Figure 2. Snubber Valve Assembly Installation.....	0706-5
CRANE HYDRAULIC FILTER AND HOUSING REPAIR.....	WP 0707
Figure 1. Hydraulic Oil Filter Housing.....	0707-3
Figure 2. Hydraulic Crane Filter.....	0707-4
Figure 3. Hydraulic Crane Filter.....	0707-5
Figure 4. Crane Hydraulic Filter.....	0707-7
Figure 5. Crane Hydraulic Filter.....	0707-8
Figure 6. Hydraulic Oil Filter Housing.....	0707-9
AUTOMATIC BRAKE (HOIST WINCH) SERVICING.....	WP 0708
Figure 1. Automatic Brake (Hoist Winch) Adjustment.....	0708-2
HOIST WINCH CABLE REPLACEMENT.....	WP 0709
Figure 1. Hoist Winch Cable Removal.....	0709-3
Figure 2. Hoist Winch Cable Removal.....	0709-4
Figure 3. Hoist Winch Cable Installation.....	0709-5

TABLE OF CONTENTS - Continued

	Page No.
	<u>WP Sequence No.</u>
Figure 4. Hoist Winch Cable Installation.....	0709-7
REAR WINCH CABLE REPLACEMENT.....	WP 0710
Figure 1. Rear Winch Cable Removal.....	0710-1
Figure 2. Rear Winch Cable Removal.....	0710-2
Figure 3. Rear Winch Cable Installation.....	0710-3
Figure 4. Rear Winch Cable Installation.....	0710-3
WRECKER CRANE HYDRAULIC HOSE AND TUBE REPLACEMENT.....	WP 0711
Figure 1. Wrecker Crane Hydraulic Hose and Tube Removal.....	0711-3
Figure 2. Wrecker Crane Hydraulic Hose and Tube Installation.....	0711-5
WRECKER CRANE HYDRAULIC PUMP REPLACEMENT.....	WP 0712
Figure 1. Wrecker Crane Hydraulic Pump Removal.....	0712-3
Figure 2. Wrecker Crane Hydraulic Pump Installation.....	0712-5
TRANSMISSION PTO-TO-HYDRAULIC PUMP PROPELLER SHAFT REPAIR.....	WP 0713
Figure 1. Transmission PTO-To-Hydraulic Pump Propeller Shaft Removal.....	0713-1
Figure 2. Transmission PTO-To-Hydraulic Pump Propeller Shaft Removal.....	0713-2
Figure 3. Transmission PTO-To-Hydraulic Pump Propeller Shaft Removal.....	0713-3
Figure 4. Transmission PTO-To-Hydraulic Pump Propeller Shaft Removal.....	0713-3
Figure 5. Transmission PTO-To-Hydraulic Pump Propeller Shaft Assembly.....	0713-4
Figure 6. Transmission PTO-To-Hydraulic Pump Propeller Shaft Assembly.....	0713-5
Figure 7. Transmission PTO-To-Hydraulic Pump Propeller Shaft Assembly.....	0713-6
Figure 8. Transmission PTO-To-Hydraulic Pump Propeller Shaft Assembly.....	0713-7
Figure 9. Transmission PTO-To-Hydraulic Pump Propeller Shaft Installation.....	0713-8
TRANSFER PTO-TO-HYDRAULIC PUMP PROPELLER SHAFT REPAIR.....	WP 0714
Figure 1. Transfer PTO-to-Hydraulic Pump Propeller Shaft Removal.....	0714-2
Figure 2. Transfer PTO-to-Hydraulic Pump Propeller Shaft Installation.....	0714-3
DUMP BODY HYDRAULIC HOSE REPLACEMENT.....	WP 0715
Figure 1. Hydraulic Hoses.....	0715-3

TABLE OF CONTENTS - Continued

	Page No.
	<u>WP Sequence No.</u>
Figure 2. Hydraulic Hoses.....	0715-4
Figure 3. Hydraulic Hoses.....	0715-5
Figure 4. Hydraulic Hoses.....	0715-6
Figure 5. Hydraulic Hoses.....	0715-7
Figure 6. Hydraulic Hoses.....	0715-8
DUMP VALVE CABLE AND SHIFT LEVER REPLACEMENT.....	WP 0716
Figure 1. Valve Cable and Shift Lever Removal.....	0716-3
Figure 2. Valve Cable and Shift Lever Installation.....	0716-5
DUMP SUBFRAME REPLACEMENT.....	WP 0717
Figure 1. Dump Subframe Removal.....	0717-3
Figure 2. Dump Subframe Removal.....	0717-5
Figure 3. Dump Subframe Removal.....	0717-7
Figure 4. Dump Subframe Installation.....	0717-9
Figure 5. Dump Subframe Installation.....	0717-10
DUMP SAFETY BRACE REPLACEMENT.....	WP 0718
Figure 1. Dump Safety Brace Removal.....	0718-2
Figure 2. Dump Safety Brace Installation.....	0718-3
DUMP HYDRAULIC PUMP REPLACEMENT.....	WP 0719
DUMP CONTROL VALVE REPLACEMENT.....	WP 0720
FRONT AND REAR WINCH CONTROL VALVE REPLACEMENT (M930/A1/A2).....	WP 0721
Figure 1. Front and Rear Winch Control Valve Removal.....	0721-2
Figure 2. Front and Rear Winch Control Valve Removal.....	0721-3
Figure 3. Front and Rear Winch Control Valve Installation.....	0721-4
Figure 4. Front and Rear Winch Control Valve Installation.....	0721-5
REAR WINCH CABLE TENSIONER REPAIR.....	WP 0722
Figure 1. Rear Winch Cable Tensioner Disassembly.....	0722-3
Figure 2. Rear Winch Cable Tensioner Disassembly.....	0722-5

TABLE OF CONTENTS - Continued

	Page No.
	<u>WP Sequence No.</u>
Figure 3. Rear Winch Cable Tensioner Assembly.....	0722-7
Figure 4. Rear Winch Assembly.....	0722-8
DUMP ROLLER ARM REPLACEMENT.....	WP 0723
Figure 1. Dump Roller Removal.....	0723-2
Figure 2. Dump Roller Installation.....	0723-3
DUMP HOIST CYLINDER REPLACEMENT.....	WP 0724
Figure 1. Dump Hoist Cylinder Removal.....	0724-2
Figure 2. Dump Hoist Cylinder Removal.....	0724-3
Figure 3. Dump Hoist Cylinder Removal.....	0724-4
Figure 4. Dump Hoist Cylinder Installation.....	0724-5
Figure 5. Dump Hoist Cylinder Installation.....	0724-6
Figure 6. Dump Hoist Cylinder Installation.....	0724-7
TRANSFER CASE POWER TAKEOFF (PTO) REPLACEMENT.....	WP 0725
Figure 1. Transfer Case PTO Removal.....	0725-3
Figure 2. PTO Shaft Disassembly.....	0725-5
Figure 3. PTO Shift Lever Disassembly.....	0725-6
Figure 4. PTO Clutch Collar Disassembly.....	0725-7
Figure 5. PTO Disassembly.....	0725-8
Figure 6. PTO Disassembly.....	0725-9
Figure 7. PTO Disassembly.....	0725-9
Figure 8. PTO Disassembly.....	0725-10
Figure 9. PTO Cleaning and Inspection.....	0725-11
Figure 10. PTO Cleaning and Inspection.....	0725-11
Figure 11. PTO Cleaning and Inspection.....	0725-12
Figure 12. PTO Cleaning and Inspection.....	0725-12
Figure 13. Transfer Case PTO Assembly.....	0725-13
Figure 14. Transfer Case PTO Assembly.....	0725-14

TABLE OF CONTENTS - Continued

	Page No.
	<u>WP Sequence No.</u>
Figure 15. Transfer Case PTO Assembly.....	0725-15
Figure 16. Transfer Case PTO Assembly.....	0725-17
Figure 17. Transfer Case PTO Assembly.....	0725-19
Figure 18. Transfer Case PTO Assembly.....	0725-20
Figure 19. Transfer Case PTO Assembly.....	0725-21
Figure 20. Transfer Case PTO Assembly.....	0725-21
Figure 21. Transfer Case PTO Installation.....	0725-23
TRANSFER CASE POWER TAKEOFF (PTO) CONTROL CABLE REPLACEMENT.....	WP 0726
Figure 1. Transfer Case PTO Control Cable Removal.....	0726-2
Figure 2. Transfer Case PTO Control Cable Removal.....	0726-3
Figure 3. Transfer Case PTO Control Cable Installation.....	0726-4
Figure 4. Transfer Case PTO Control Cable Installation.....	0726-5
TRANSFER CASE POWER TAKEOFF (PTO) CROSS SHAFT (CONTROL LEVER) REPLACEMENT.....	WP 0727
Figure 1. Transfer Case PTO Cross Shaft (Control Lever) Removal.....	0727-3
Figure 2. Transfer Case PTO Cross Shaft (Control Lever) Installation.....	0727-5
TRANSMISSION POWER TAKEOFF (PTO) REPLACEMENT.....	WP 0728
Figure 1. Transmission PTO Removal.....	0728-3
Figure 2. Transmission PTO Removal.....	0728-5
Figure 3. Transmission PTO Installation.....	0728-7
Figure 4. Transmission PTO Installation.....	0728-9
TRANSMISSION POWER TAKEOFF (PTO) CONTROL CABLE REPLACEMENT.....	WP 0729
Figure 1. Transmission Control Cable Removal.....	0729-2
Figure 2. Transmission Control Cable Removal.....	0729-3
Figure 3. Transmission Control Cable Installation.....	0729-4
Figure 4. Transmission Control Cable Installation.....	0729-5
TRANSMISSION POWER TAKEOFF (PTO) CONTROL CABLE REPLACEMENT (M939A2).....	WP 0730

TABLE OF CONTENTS - Continued

	Page No.
	<u>WP Sequence No.</u>
Figure 1. Transmission PTO Control Cable Removal (M939A2).....	0730-2
Figure 2. Transmission PTO Control Cable Removal (M939A2).....	0730-3
Figure 3. Transmission PTO Control Cable Installation (M939A2).....	0730-4
Figure 4. Transmission PTO Control Cable Installation (M939A2).....	0730-5
CARGO BODY COVER BOWS REPLACEMENT.....	WP 0731
Figure 1. Cargo Body Cover Bows Removal.....	0731-2
Figure 2. Cargo Body Cover Bows Installation.....	0731-3
CAB TURNBUTTONS AND LASHING HOOKS REPLACEMENT.....	WP 0732
Figure 1. Cab Turnbuttons and Lashing Hooks Removal.....	0732-2
Figure 2. Cab Turnbuttons and Lashing Hooks Installation.....	0732-3
CAB TOP SEAL AND RETAINER REPAIR.....	WP 0733
Figure 1. Cab Top Seal and Retainer Repair.....	0733-1
Figure 2. Cab Top Seal and Retainer Installation.....	0733-2
CARGO LOWER WHEEL SPLASH GUARD REPLACEMENT.....	WP 0734
Figure 1. Lower Wheel Splash Guard Replacement.....	0734-1
Figure 2. Lower Wheel Splash Guard Installation.....	0734-2
WINDSHIELD WIPER CONTROL VALVE REPLACEMENT.....	WP 0735
Figure 1. Windshield Wiper Control Valve Removal.....	0735-3
Figure 2. Windshield Wiper Control Valve Installation.....	0735-4
WINDSHIELD WIPER BLADE, WIPER ARM, AND WIPER MOTOR REPLACEMENT.....	WP 0736
Figure 1. Windshield Wiper Blade, Wiper Arm, and Wiper Motor Removal.....	0736-3
Figure 2. Windshield Wiper Blade, Wiper Arm, and Wiper Motor Removal.....	0736-4
WINDSHIELD WIPER RESERVOIR, JET, CONTROL, AND WASHER HOSES REPLACEMENT.....	WP 0737
Figure 1. Windshield Washer Hoses Removal.....	0737-2
Figure 2. Windshield Washer Hoses Installation.....	0737-3
Figure 3. Windshield Wiper Reservoir Removal.....	0737-5
Figure 4. Windshield Wiper Reservoir Installation.....	0737-7

TABLE OF CONTENTS - Continued

	Page No.
	<u>WP Sequence No.</u>
REARVIEW MIRROR AND BRACE REPLACEMENT.....	WP 0738
Figure 1. Rearview Mirror and Brace Removal.....	0738-3
Figure 2. Rearview Mirror and Brace Installation.....	0738-5
WASHER CONTROL VALVE REPLACEMENT.....	WP 0739
Figure 1. Washer Control Valve Removal.....	0739-3
Figure 2. Washer Control Valve Installation.....	0739-4
REFLECTORS REPLACEMENT.....	WP 0740
Figure 1. Reflectors Removal.....	0740-1
Figure 2. Reflectors Installation.....	0740-2
FRESH AIR VENT CONTROL CABLE ASSEMBLY REPLACEMENT.....	WP 0741
Figure 1. Fresh Air Vent Control Assembly Removal.....	0741-1
Figure 2. Fresh Air Vent Control Assembly Removal.....	0741-2
Figure 3. Fresh Air Vent Control Assembly Installation.....	0741-3
Figure 4. Fresh Air Vent Control Assembly Installation.....	0741-4
DIVERTER ASSEMBLY REPLACEMENT.....	WP 0742
Figure 1. Diverter Assembly Removal.....	0742-1
Figure 2. Diverter Assembly Removal.....	0742-2
Figure 3. Diverter Assembly Installation.....	0742-3
Figure 4. Diverter Assembly Installation.....	0742-4
FRESH AIR INLET DUCTING REPLACEMENT.....	WP 0743
Figure 1. Fresh Air Inlet Ducting Removal.....	0743-2
Figure 2. Fresh Air Inlet Ducting Installation.....	0743-3
CAB HEAT AND DEFROST AIR DUCTING REPLACEMENT.....	WP 0744
Figure 1. Cab Heat and Defrost Air Ducting Removal.....	0744-1
Figure 2. Cab Heat and Defrost Air Ducting Installation.....	0744-2
DEFROST AND HEAT CONTROLS REPLACEMENT.....	WP 0745
Figure 1. Defrost and Heat Controls Removal.....	0745-2

TABLE OF CONTENTS - Continued

	Page No.
	<u>WP Sequence No.</u>
Figure 2. Defrost and Heat Controls Removal.....	0745-3
Figure 3. Defrost and Heat Controls Installation.....	0745-4
Figure 4. Defrost and Heat Controls Installation.....	0745-5
PERSONNEL HEATER HOSES REPLACEMENT.....	WP 0746
Figure 1. Personnel Heater Hoses Removal.....	0746-3
Figure 2. Personnel Heater Hoses Installation.....	0746-4
PERSONNEL HOT WATER HEATER REPLACEMENT.....	WP 0747
Figure 1. Personnel Hot Water Heater Removal.....	0747-3
Figure 2. Personnel Hot Water Heater Installation.....	0747-5
ENGINE COOLANT HEATER REPLACEMENT.....	WP 0748
Figure 1. Engine Coolant Heater Removal.....	0748-3
Figure 2. Engine Coolant Heater Installation.....	0748-5
RADIATOR COVER KIT REPLACEMENT.....	WP 0749
Figure 1. Radiator Cover Kit Removal.....	0749-1
Figure 2. Radiator Cover Kit Installation.....	0749-2
HARDTOP KIT REPLACEMENT.....	WP 0750
Figure 1. Hardtop Kit Removal.....	0750-3
Figure 2. Hardtop Kit Installation.....	0750-5
PERSONNEL FUEL BURNING HEATER AND MOUNTING BRACKET REPLACEMENT (M939/A1).....	WP 0751
Figure 1. Personnel Fuel Burning Heater and Mounting Bracket Removal (M939/A1).....	0751-2
Figure 2. Personnel Fuel Burning Heater and Mounting Bracket Installation (M939/A1).....	0751-3
ENGINE COOLANT HEATER PUMP REPLACEMENT.....	WP 0752
Figure 1. Engine Coolant Heater Pump Removal.....	0752-3
Figure 2. Engine Coolant Heater Pump Installation.....	0752-5
ENGINE COOLANT HEATER CONTROL BOX REPLACEMENT.....	WP 0753
Figure 1. Engine Coolant Heater Control Box Removal.....	0753-2
Figure 2. Engine Coolant Heater Control Box Installation.....	0753-3

TABLE OF CONTENTS - Continued

	Page No.
	<u>WP Sequence No.</u>
ENGINE COOLANT HEATER HARNESS REPLACEMENT (M939/A1).....	WP 0754
Figure 1. Engine Coolant Heater Harness Removal.....	0754-3
Figure 2. Engine Coolant Heater Harness Installation.....	0754-5
ENGINE COOLANT HEATER HARNESS REPLACEMENT (M939/A2).....	WP 0755
Figure 1. Engine Coolant Heater Harness Removal.....	0755-3
Figure 2. Engine Coolant Heater Harness Installation.....	0755-5
ENGINE COOLANT OIL PAN SHROUD AND EXHAUST TUBE REPLACEMENT.....	WP 0756
Figure 1. Engine Coolant Oil Pan Shroud and Exhaust Tube Removal.....	0756-2
Figure 2. Engine Coolant Oil Pan Shroud and Exhaust Tube Installation.....	0756-3
ENGINE COOLANT HEATER HOSE REPLACEMENT.....	WP 0757
Figure 1. Engine Coolant Heater Hose Removal.....	0757-3
Figure 2. Engine Coolant Heater Hose Removal.....	0757-5
Figure 3. Engine Coolant Heater Hose Removal.....	0757-6
Figure 4. Engine Coolant Heater Hose Installation.....	0757-7
Figure 5. Hoses and Electrical Harness Installation.....	0757-9
Figure 6. Engine Coolant Heater Hose Installation.....	0757-11
ENGINE COOLANT BATTERY BOX HEATER PAD REPLACEMENT.....	WP 0758
Figure 1. Engine Coolant Battery Box Heater Pad Removal.....	0758-3
Figure 2. Engine Coolant Battery Box Heater Pad Installation.....	0758-5
PERSONNEL FUEL BURNING HEATER CONTROL BOX REPLACEMENT.....	WP 0759
Figure 1. Personnel Fuel Burning Heater Control Box Removal.....	0759-2
Figure 2. Personnel Fuel Burning Heater Control Box Installation.....	0759-3
PERSONNEL FUEL BURNING HEATER AND MOUNTING BRACKETS REPLACEMENT (M939A2).....	WP 0760
Figure 1. Personnel Fuel Burning Heater and Mounting Brackets Removal.....	0760-3
Figure 2. Personnel Fuel Burning Heater and Mounting Brackets Installation.....	0760-4
PERSONNEL FUEL BURNING HEATER FUEL PUMP REPLACEMENT (M939/A1).....	WP 0761
Figure 1. Personnel Fuel Burning Heater Fuel Pump Removal.....	0761-3

TABLE OF CONTENTS - Continued

	Page No.
	<u>WP Sequence No.</u>
Figure 2. Personnel Fuel Burning Heater Fuel Pump Installation.....	0761-5
PERSONNEL FUEL BURNING HEATER ELECTRIC FUEL PUMP REPLACEMENT (M939A2).....	WP 0762
Figure 1. Personnel Fuel Burning Heater Electric Fuel Pump Removal.....	0762-3
Figure 2. Personnel Fuel Burning Heater Electric Fuel Pump Installation.....	0762-4
PERSONNEL FUEL BURNING HEATER FUEL SHUTOFF VALVE REPLACEMENT.....	WP 0763
Figure 1. Fuel Burning Heater Fuel Shutoff Valve Removal.....	0763-3
Figure 2. Fuel Burning Heater Fuel Shutoff Valve Installation.....	0763-5
PERSONNEL FUEL BURNING HEATER WIRING HARNESS REPLACEMENT.....	WP 0764
Figure 1. Personnel Fuel Burning Heater Wiring Harness Removal.....	0764-3
Figure 2. Personnel Fuel Burning Heater Wiring Harness Installation.....	0764-5
PERSONNEL FUEL BURNING HEATER EXHAUST TUBE REPLACEMENT (M939/A1).....	WP 0765
Figure 1. Fuel Burning Heater Exhaust Tube Removal.....	0765-3
Figure 2. Fuel Burning Heater Exhaust Tube Installation.....	0765-5
PERSONNEL FUEL BURNING HEATER EXHAUST TUBE REPLACEMENT (M939A2).....	WP 0766
Figure 1. Fuel Burning Heater Exhaust Tube Removal.....	0766-3
Figure 2. Fuel Burning Heater Exhaust Tube Installation.....	0766-4
PERSONNEL FUEL BURNING HEATER CIRCUIT BREAKER REPLACEMENT.....	WP 0767
Figure 1. Personnel Fuel Burning Heater Circuit Breaker Removal.....	0767-2
Figure 2. Personnel Fuel Burning Heater Circuit Breaker Installation.....	0767-3
DEEPWATER FORDING CONTROL CABLE REPLACEMENT.....	WP 0768
Figure 1. Deepwater Fording Control Removal.....	0768-3
Figure 2. Deepwater Fording Control Installation.....	0768-5
DEEPWATER FORDING PRESSURIZATION VALVE REPLACEMENT.....	WP 0769
Figure 1. Deepwater Fording Pressurization Valve Removal (M939/A1).....	0769-3
Figure 2. Deepwater Fording Pressurization Valve Removal (M939/A2).....	0769-5
Figure 3. Deepwater Fording Pressurization Valve Installation (M939/A2).....	0769-7
Figure 4. Deepwater Fording Pressurization Valve Installation (M939/A1).....	0769-9

TABLE OF CONTENTS - Continued

	Page No.
	<u>WP Sequence No.</u>
DEEPWATER FORDING AIR PRESSURE HOSE REPLACEMENT.....	WP 0770
Figure 1. Deepwater Fording Air Pressure Hose Removal (M939/A1).....	0770-3
Figure 2. Deepwater Fording Air Pressure Hose Removal (M939A2).....	0770-5
Figure 3. Deepwater Fording Air Pressure Hose Installation (M939A2).....	0770-7
Figure 4. Deepwater Fording Air Pressure Hose Installation (M939/A1).....	0770-9
Index	
Volume 5	
Chapter 10 - MAINTENANCE INSTRUCTIONS	
DEEPWATER FORDING REGULATOR VALVE REPLACEMENT.....	WP 0771
Figure 1. Deepwater Fording Regulator Valve Removal.....	0771-2
Figure 2. Deepwater Fording Regulator Valve Installation.....	0771-3
A-FRAME COMPONENTS REPLACEMENT.....	WP 0772
Figure 1. A-Frame Components Removal.....	0772-3
Figure 2. A-Frame Components Removal.....	0772-5
Figure 3. A-Frame Components Installation.....	0772-7
Figure 4. A-Frame Components.....	0772-9
FIRE EXTINGUISHER MOUNTING BRACKET REPLACEMENT.....	WP 0773
Figure 1. Fire Extinguisher Mounting Bracket Removal.....	0773-2
Figure 2. Fire Extinguisher Mounting Bracket Installation.....	0773-3
CHEMICAL AGENT ALARM MOUNTING BRACKET REPLACEMENT.....	WP 0774
Figure 1. Chemical Agent Alarm Wiring Harness Removal.....	0774-3
Figure 2. Chemical Agent Alarm Wiring Harness Removal.....	0774-5
Figure 3. Detector and Alarm Bracket Removal.....	0774-7
Figure 4. Detector and Alarm Bracket Installation.....	0774-8
Figure 5. Chemical Agent Alarm Wiring Harness Installation.....	0774-9
Figure 6. Chemical Agent Alarm Wiring Harness Installation.....	0774-10
LIGHTWEIGHT WEAPON STATION MODIFICATION COMPONENT REPLACEMENT.....	WP 0775

TABLE OF CONTENTS - Continued

	Page No.
	<u>WP Sequence No.</u>
Figure 1. Weapon Station Removal.....	0775-2
Figure 2. Weapon Station Removal.....	0775-3
Figure 3. Weapon Station Removal.....	0775-4
Figure 4. Weapon Station Removal.....	0775-5
Figure 5. Weapon Station Removal.....	0775-7
Figure 6. Weapon Station Removal.....	0775-9
Figure 7. Weapon Station Removal.....	0775-11
Figure 8. Weapon Station Removal.....	0775-13
Figure 9. Weapon Station Disassembly.....	0775-15
Figure 10. Weapon Station Disassembly.....	0775-17
Figure 11. Weapon Station Disassembly.....	0775-19
Figure 12. Weapon Station Disassembly.....	0775-20
Figure 13. Lightweight Weapon Station Assembly.....	0775-21
Figure 14. Lightweight Weapon Station Assembly.....	0775-23
Figure 15. Lightweight Weapon Station Assembly.....	0775-25
Figure 16. Lightweight Weapon Station Assembly.....	0775-26
Figure 17. Lightweight Weapon Station Installation.....	0775-27
Figure 18. Lightweight Weapon Station Installation.....	0775-28
Figure 19. Lightweight Weapon Station Installation.....	0775-29
Figure 20. Lightweight Weapon Station Installation.....	0775-30
Figure 21. Lightweight Weapon Station Installation.....	0775-31
Figure 22. Lightweight Weapon Station Installation.....	0775-32
Figure 23. Lightweight Weapon Station Installation.....	0775-33
Figure 24. Lightweight Weapon Station Installation.....	0775-35
Figure 25. Lightweight Weapon Station Installation.....	0775-37
Figure 26. Light Weapon Station Installation.....	0775-39
Figure 27. Lightweight Weapon Station Installation.....	0775-40

TABLE OF CONTENTS - Continued

	Page No.
	<u>WP Sequence No.</u>
Figure 28. Lightweight Weapon Station Installation.....	0775-41
DECONTAMINATION APPARATUS AND MOUNTING BRACKET REPLACEMENT (M13).....	WP 0776
Figure 1. Decontamination Apparatus and Mounting Bracket Removal (M929/A1/A2, M930/A1/A2, M931/A1/A2, M932/A1/A2).....	0776-2
Figure 2. Decontamination Apparatus and Mounting Bracket Installation (M929/A1/A2, M930/A1/A2, M931/A1/A2, M932/A1/A2).....	0776-3
Figure 3. Decontamination Apparatus and Mounting Bracket Removal (M934/A1/A2).....	0776-4
Figure 4. Decontamination Apparatus and Mounting Bracket Installation (M934/A1/A2).....	0776-5
Figure 5. Decontamination Apparatus Components Removal (M939/A1/A2).....	0776-6
Figure 6. Decontamination Apparatus Components Installation (M939/A1/A2).....	0776-7
Figure 7. Decontamination Apparatus Components Removal (M923/A1/A2, M925/A1/ A2, M927/A1/A2, M928/A1/A2).....	0776-8
Figure 8. Decontamination Apparatus Components Installation (M923/A1/A2, M925/A1/ A2, M927/A1/A2, M928/A1/A2).....	0776-9
MUD GUARD KIT (M931/A1/A2, M932/A1/A2) REPAIR.....	WP 0777
Figure 1. Mud Guard Removal.....	0777-2
Figure 2. Mud Guard Installation.....	0777-3
RIFLE MOUNTING COMPONENTS REPLACEMENT.....	WP 0778
Figure 1. Left Door Rifle Mounting.....	0778-2
Figure 2. Dash and Floor Rifle Mounting.....	0778-3
Figure 3. Left Door Rifle Mounting.....	0778-4
Figure 4. Dash and Floor Rifle Mounting.....	0778-5
HAND AIRBRAKE AIR SUPPLY VALVE REPLACEMENT.....	WP 0779
Figure 1. Hand Airbrake Air Supply Valve Removal.....	0779-3
Figure 2. Hand Airbrake Air Supply Valve Installation.....	0779-5
100-AMP ALTERNATOR REPLACEMENT.....	WP 0780
Figure 1. 100-Amp Alternator Removal.....	0780-2
Figure 2. 100-Amp Alternator Installation.....	0780-3
CONVOY WARNING LIGHT MOUNT REPLACEMENT.....	WP 0781

TABLE OF CONTENTS - Continued

	Page No.
	<u>WP Sequence No.</u>
Figure 1. Convoy Warning Light Mount Removal.....	0781-3
Figure 2. Convoy Warning Light Mount Installation.....	0781-5
EUROPEAN MINI-LIGHTING COMPONENT REPLACEMENT.....	WP 0782
Figure 1. European Mini-Lighting Component Removal.....	0782-3
Figure 2. European Mini-Lighting Component Installation.....	0782-5
AUTOMATIC THROTTLE COMPONENT REPLACEMENT (M936/A1).....	WP 0783
Figure 1. Automatic Throttle Component Removal.....	0783-3
Figure 2. Automatic Throttle Component Removal.....	0783-4
Figure 3. Automatic Throttle Component Removal.....	0783-5
Figure 4. Automatic Throttle Component Installation.....	0783-6
Figure 5. Automatic Throttle Component Installation.....	0783-7
Figure 6. Automatic Throttle Component Installation.....	0783-8
Figure 7. Automatic Throttle Component Installation.....	0783-9
ATMOSPHERIC FUEL TANK VENT SYSTEM REPLACEMENT.....	WP 0784
Figure 1. Atmospheric Fuel Tank Vent System Component Removal.....	0784-2
Figure 2. Atmospheric Fuel Tank Vent System Component Removal.....	0784-3
Figure 3. Atmospheric Fuel Tank Vent System Component Removal.....	0784-5
Figure 4. Atmospheric Fuel Tank Vent System Component Removal.....	0784-7
Figure 5. Atmospheric Fuel Tank Vent System Component Installation.....	0784-9
Figure 6. Atmospheric Fuel Tank Vent System Component Installation.....	0784-10
Figure 7. Atmospheric Fuel Tank Vent system component Installation.....	0784-11
Figure 8. Atmospheric Fuel Tank Vent System Component Installation.....	0784-12
HYDRAULIC HOSE CHAFE GUARD COMPONENT REPLACEMENT.....	WP 0785
Figure 1. Hydraulic Hose Chafe Guard Component Removal.....	0785-3
Figure 2. Hydraulic Hose Chafe Guard Component Removal.....	0785-4
Figure 3. Hydraulic Hose Chafe Guard Component Installation.....	0785-5
Figure 4. Hydraulic Hose Chafe Guard Component Installation.....	0785-7

TABLE OF CONTENTS - Continued

	Page No.
	<u>WP Sequence No.</u>
HYDRAULIC RESERVOIR DRAIN REPLACEMENT.....	WP 0786
Figure 1. Hydraulic Reservoir Drain Removal.....	0786-3
Figure 2. Hydraulic Reservoir Drain Removal.....	0786-4
Figure 3. Hydraulic Reservoir Drain Installation.....	0786-5
Figure 4. Reservoir Drain Installation.....	0786-6
HYDRAULIC RESERVOIR SHUTOFF MODIFICATION REPLACEMENT (M936/A1/A2).....	WP 0787
Figure 1. Hydraulic Reservoir Shutoff Modification Component Removal (M936/A1/A2).....	0787-2
Figure 2. Hydraulic Reservoir Shutoff Modification Component Removal (M936/A1/A2).....	0787-3
Figure 3. Hydraulic Oil Reservoir Shutoff Modification Component Removal (M936/A1/A2).....	0787-4
Figure 4. Hydraulic Oil Reservoir Shutoff Modification Component Installation (M936/A1/A2).....	0787-5
Figure 5. Hydraulic Reservoir Shutoff Modification Component Installation (M936/A1/A2).....	0787-6
Figure 6. Hydraulic Reservoir Shutoff Modification Component Installation (M936/A1/A2).....	0787-7
VAN HANDRAIL COMPONENT REPLACEMENT (M934/A1/A2).....	WP 0788
Figure 1. Van Handrail Component Removal (M934/A1/A2).....	0788-1
Figure 2. Van Handrail Component Installation (M934/A1/A2).....	0788-2
Figure 3. Van Handrail Component Removal (M934/A1/A2).....	0788-3
Figure 4. Van Handrail Component Removal (M934/A1/A2).....	0788-4
Figure 5. Van Handrail Component Installation (M934/A1/A2).....	0788-5
Figure 6. Van Handrail Component Installation (M934/A1/A2).....	0788-6
Figure 7. Van Handrail Component Removal (M934/A1/A2).....	0788-7
Figure 8. Van Handrail Component Installation (M934/A1/A2).....	0788-8
Figure 9. Van Handrail Component Removal (M934/A1/A2).....	0788-9
Figure 10. Van Handrail Component Installation (M934/A1/A2).....	0788-10
EXHAUST HEAT SHIELD ACCESSORY KIT REPLACEMENT.....	WP 0789
Figure 1. Exhaust Heat Shield Accessory Kit Removal.....	0789-1
Figure 2. Exhaust Heat Shield Accessory Kit Installation.....	0789-2
SEATBELT REPLACEMENT.....	WP 0790

TABLE OF CONTENTS - Continued

	Page No.
	<u>WP Sequence No.</u>
Figure 1. Driver's Seatbelt Removal.....	0790-3
Figure 2. Driver's Seatbelt Installation.....	0790-5
Figure 3. Companion Seatbelt Removal.....	0790-7
Figure 4. Companion Seatbelt Installation.....	0790-9
HAND AIRBRAKE CONTROLLER VALVE REPLACEMENT.....	WP 0791
Figure 1. Hand Airbrake Controller Valve Removal.....	0791-3
Figure 2. Hand Airbrake Controller Valve Installation.....	0791-4
100-AMP ALTERNATOR HARNESS REPLACEMENT.....	WP 0792
Figure 1. 100-AMP Alternator Harness.....	0792-2
Figure 2. 100-AMP Alternator Ground Strap Removal.....	0792-3
Figure 3. 100-AMP Alternator Ground Strap Installation.....	0792-4
Figure 4. 100-AMP Alternator Harness.....	0792-5
100-AMP VOLTAGE REGULATOR REPLACEMENT.....	WP 0793
Figure 1. 100-AMP Voltage Regulator Removal.....	0793-3
Figure 2. 100-AMP Voltage Regulator Installation.....	0793-5
CONVOY WARNING LIGHT MOUNT REPLACEMENT (M934/A1/A2).....	WP 0794
Figure 1. Convoy Warning Light (M934/A1/A2) Removal.....	0794-3
Figure 2. Convoy Warning Light (M934/A1/A2) Installation.....	0794-5
CONVOY WARNING LIGHT MOUNT REPLACEMENT (M929/A1/A2, M930/A1/A2).....	WP 0795
Figure 1. Convoy Warning Light Mount Removal.....	0795-3
Figure 2. Convoy Warning Light Mount Installation.....	0795-4
CONVOY WARNING LIGHT HARNESS REPLACEMENT.....	WP 0796
Figure 1. Convoy Warning Light Harness Removal.....	0796-3
Figure 2. Convoy Warning Light Harness Installation.....	0796-5
CONVOY WARNING LIGHT HARNESS REPLACEMENT (M929/A1/A2, M930/A1/A2).....	WP 0797
Figure 1. Convoy Warning Light Harness Removal.....	0797-2
Figure 2. Convoy Warning Light Harness Removal.....	0797-3

TABLE OF CONTENTS - Continued

	Page No.
	<u>WP Sequence No.</u>
Figure 3. Convoy Warning Light Harness Installation.....	0797-4
Figure 4. Convoy Warning Light Harness Installation.....	0797-5
CONVOY WARNING LIGHT HARNESS REPLACEMENT (M934/A1/A2).....	WP 0798
Figure 1. Convoy Warning Light Harness Removal.....	0798-3
Figure 2. Convoy Warning Light Harness Installation.....	0798-5
CONVOY WARNING LIGHT REPLACEMENT.....	WP 0799
Figure 1. Convoy Warning Light Removal.....	0799-3
Figure 2. Convoy Warning Light Installation.....	0799-5
CONVOY WARNING LIGHT SWITCH REPLACEMENT.....	WP 0800
Figure 1. Convoy Warning Light Switch Removal.....	0800-3
Figure 2. Convoy Warning Light Switch Installation.....	0800-5
PIONEER TOOL KIT MOUNTING BRACKET REPLACEMENT.....	WP 0801
Figure 1. Pioneer Tool Kit Mounting Bracket Removal.....	0801-2
Figure 2. Pioneer Tool Kit Mounting Bracket Installation.....	0801-3
Figure 3. Pioneer Tool Kit Mounting Bracket Removal.....	0801-4
Figure 4. Pioneer Tool Kit Mounting Bracket Installation.....	0801-5
Figure 5. Pioneer Tool Kit Mounting Bracket Removal.....	0801-6
Figure 6. Pioneer Tool Kit Mounting Bracket Installation.....	0801-7
Figure 7. Pioneer Tool Kit Mounting Bracket Removal.....	0801-8
Figure 8. Pioneer Tool Kit Mounting Bracket Installation.....	0801-9
HAND AIRBRAKE DOUBLE CHECK VALVES REPLACEMENT.....	WP 0802
Figure 1. Forward-Rear Axle Double Check Valve Removal.....	0802-3
Figure 2. Forward-Rear Axle Double Check Valve Installation.....	0802-5
Figure 3. Rear-Rear Axle Double Check Valve Removal.....	0802-7
Figure 4. Rear-Rear Axle Double Check Valve Installation.....	0802-9
HAND AIRBRAKE TRACTOR PROTECTION VALVE REPLACEMENT.....	WP 0803
Figure 1. Hand Airbrake Tractor Protection Valve Removal.....	0803-2

TABLE OF CONTENTS - Continued

	Page No.
	<u>WP Sequence No.</u>
Figure 2. Hand Airbrake Tractor Protection Valve Installation.....	0803-3
CONVOY WARNING LIGHT RELAY AND LEADS REPLACEMENT.....	WP 0804
Figure 1. Convoy Warning Light Relay and Leads Removal.....	0804-3
Figure 2. Convoy Warning Light Relay and Leads Installation.....	0804-5
AIR LINES FABRICATION.....	WP 0805
AIR DRYER FILTER REPLACEMENT.....	WP 0806
Figure 1. Air Dryer Kit Removal.....	0806-2
Figure 2. Air Dryer Kit Removal.....	0806-3
Figure 3. Air Dryer Kit Removal.....	0806-4
Figure 4. Air Dryer Kit Removal.....	0806-4
Figure 5. Air Dryer Kit Removal.....	0806-5
Figure 6. Air Dryer Kit Removal.....	0806-6
Figure 7. Air Dryer Kit Removal.....	0806-7
Figure 8. Air Dryer Kit Removal.....	0806-9
Figure 9. Air Dryer Kit Installation.....	0806-11
Figure 10. Air Dryer Kit Installation.....	0806-12
Figure 11. Air Dryer Kit Installation.....	0806-13
Figure 12. Air Dryer Kit Installation.....	0806-14
Figure 13. Air Dryer Kit Installation.....	0806-15
Figure 14. Air Dryer Kit Installation.....	0806-16
Figure 15. Air Dryer Kit Installation.....	0806-17
Figure 16. Air Dryer Kit Installation.....	0806-18
Figure 17. Air Dryer Kit Installation.....	0806-19
AIR DRYER AND MOUNTING BRACKETS REPLACEMENT.....	WP 0807
Figure 1. Air Dryer Removal.....	0807-3
Figure 2. Air Dryer and Mounting Brackets Installation.....	0807-5
AIR DRYER HEATER REPLACEMENT.....	WP 0808

TABLE OF CONTENTS - Continued

	Page No.
	<u>WP Sequence No.</u>
Figure 1. Air Dryer Heater Removal.....	0808-2
Figure 2. Air Dryer Heater Installation.....	0808-3
RELIEF SAFETY VALVE REPLACEMENT.....	WP 0809
Figure 1. Relief Valve Removal.....	0809-3
Figure 2. Relief Valve Removal.....	0809-4
Figure 3. Relief Valve Installation.....	0809-5
Figure 4. Relief Valve Installation.....	0809-7
PNEUMATIC CONTROLLER AND RELIEF VALVE REPAIR.....	WP 0810
Figure 1. Pneumatic Controller Removal.....	0810-2
Figure 2. Pneumatic Controller Disassembly.....	0810-3
Figure 3. Wiring Harness Inspection.....	0810-5
Table 1. Electrical Connections.....	0810-5
Figure 4. Pneumatic Controller Assembly.....	0810-7
Figure 5. Pneumatic Controller Installation.....	0810-8
WATER SEPARATOR REPLACEMENT.....	WP 0811
Figure 1. Water Separator Removal.....	0811-3
Figure 2. Water Separator Installation.....	0811-5
PRESSURE TRANSDUCER REPLACEMENT.....	WP 0812
Figure 1. Pressure Transducer Removal.....	0812-1
Figure 2. Pressure Transducer Removal.....	0812-2
Figure 3. Pressure Transducer Removal.....	0812-3
Figure 4. Pressure Transducer Removal.....	0812-4
Figure 5. Pressure Transducer Installation.....	0812-5
Figure 6. Pneumatic Controller Installation.....	0812-6
Figure 7. Pneumatic Transducer Installation.....	0812-7
Figure 8. Pneumatic Transducer Installation.....	0812-8
Figure 9. Pressure Transducer Installation.....	0812-9

TABLE OF CONTENTS - Continued

	Page No.
	<u>WP Sequence No.</u>
ELECTRONIC CONTROL UNIT (ECU) REPLACEMENT.....	WP 0813
Figure 1. Electronic Control Unit Removal.....	0813-1
Figure 2. Electronic Control Unit Installation.....	0813-2
SPEEDOMETER DRIVESHAFT MAINTENANCE.....	WP 0814
Figure 1. Speedometer Driveshaft Removal.....	0814-1
Figure 2. Speedometer Driveshaft Removal.....	0814-2
Figure 3. Speedometer Driveshaft Removal.....	0814-3
Figure 4. Speedometer Driveshaft Removal.....	0814-4
Figure 5. Speedometer Driveshaft Installation.....	0814-5
Figure 6. Speedometer Driveshaft Installation.....	0814-6
Figure 7. Speedometer Instrument Cluster Installation.....	0814-7
Figure 8. Speedometer Driveshaft Installation.....	0814-8
SPEEDOMETER AND TACHOMETER REPLACEMENT.....	WP 0815
Figure 1. Speedometer Removal.....	0815-2
Figure 2. Speedometer Installation.....	0815-3
TACHOMETER DRIVE REPLACEMENT.....	WP 0816
Figure 1. Tachometer Drive Removal.....	0816-1
Figure 2. Tachometer Drive Installation.....	0816-2
TACHOMETER DRIVESHAFT REPAIR.....	WP 0817
Figure 1. Tachometer Removal.....	0817-2
Figure 2. Tachometer Installation.....	0817-3
AIR GAUGE REPLACEMENT.....	WP 0818
Figure 1. Air Gauge Removal.....	0818-3
Figure 2. Air Gauge Installation.....	0818-4
GENERAL MAINTENANCE INSTRUCTIONS.....	WP 0819
LUBRICATION INSTRUCTIONS.....	WP 0820
Table 1. -KEY-	0820-2

TABLE OF CONTENTS - Continued

	Page No.
	<u>WP Sequence No.</u>
Table 2. Total Man-Hours.	0820-6
Figure 1. Truck Chassis.	0820-7
Figure 2. Truck Chassis.	0820-8
Figure 3. Truck Chassis.	0820-9
Figure 4. Truck Chassis.	0820-10
Figure 5. Fifth Wheel/Van Body.	0820-11
Figure 6. Van Body.	0820-12
Figure 7. Wrecker/Dump Body.	0820-13
Figure 8. Wrecker Crane.	0820-14
Figure 9. Wrecker Crane.	0820-15
Figure 10. Rear Winch.	0820-16
Figure 11. Front Winch.	0820-17
Figure 12. Propeller Shaft.	0820-18
Figure 13. Localized Lubrication.	0820-19
Figure 14. Localized Lubrication.	0820-20
Figure 15. Localized Lubrication.	0820-21
Figure 16. Localized Lubrication.	0820-22
Figure 17. Localized Lubrication.	0820-23
Figure 18. Localized Lubrication.	0820-24
Figure 19. Localized Lubrication.	0820-25
Figure 20. Localized Lubrication.	0820-26
Figure 21. Localized Lubrication.	0820-27
Figure 22. Localized Lubrication.	0820-28
Figure 23. Localized Lubrication.	0820-29
TORQUE LIMITS.....	WP 0821
Figure 1. Screw Diameter.....	0821-1
Figure 2. Threads Per Inch.....	0821-1

TABLE OF CONTENTS - Continued

	Page No.
	<u>WP Sequence No.</u>
Figure 3. Torque Wrench Adapter Conversion Formula.....	0821-3
Table 1. Torque Limits for Dry Fasteners.....	0821-4
Table 2. Torque Limits for Wet Fasteners.....	0821-6
Table 3. Torque Limits for Metric Fasteners.....	0821-8
Figure 4. Mini-Barb.....	0821-8
Figure 5. Knurl-On.....	0821-9
Figure 6. Self-Align-PTF.....	0821-9
Figure 7. Nylon Tubing for Airbrake.....	0821-9
Figure 8. Copper Tubing for Hand Airbrake.....	0821-10
Chapter 11 - SUPPORTING INFORMATION	
REFERENCES.....	WP 0822
INTRODUCTION FOR STANDARD TWO-LEVEL MAC.....	WP 0823
MAINTENANCE ALLOCATION CHART (MAC).....	WP 0824
Table 1. MAINTENANCE ALLOCATION CHART (MAC).....	0824-1
Table 2. Tools and Test Equipment Requirements.....	0824-76
Table 3. Remarks.....	0824-77
EXPENDABLE/DURABLE ITEMS LIST.....	WP 0825
Table 1. Expendable/Durable Supplies and Materials List.....	0825-2
TOOL IDENTIFICATION LIST.....	WP 0826
Table 1. Tool Identification List.....	0826-1
MANDATORY REPLACEMENT PARTS LIST.....	WP 0827
Table 1. MANDATORY REPLACEMENT PARTS LIST.....	0827-1
SCHEMATICS.....	WP 0828
Foldout Figures	
FO-1. M939/A1 Electrical System Wiring Diagram (1 of 2).....	FP-1
FO-2. M939/A1 Electrical System Wiring Diagram (2 of 2).....	FP-3
FO-3. M939A2 Electrical System Wiring Diagram (1 of 2).....	FP-5

TABLE OF CONTENTS - Continued

	Page No.
	<u>WP Sequence No.</u>
FO-4. M939A2 Electrical System Wiring Diagram (2 of 2).....	FP-7
FO-5. M934/A1/A2 Electrical Wiring Diagram for Expansable Van.....	FP-9
FO-6. M939/A1/A2 WO/ABS Air Supply Line Diagram.....	FP-11
FO-7. M939/A1/A2 W/ABS Air Supply Line Diagram.....	FP-13
FO-8. M939/A1/A2 WO/ABS Air Control Line Diagram.....	FP-15
FO-9. M939/A1/A2 W/ABS Air Control Line Diagram.....	FP-17
FO-10. M939/A1/A2 Air Vent Line Diagram.....	FP-19
FO-11. M939A2 C.T.I.S. Electrical System Wiring Diagram.....	FP-21
FO-12. M939A2 C.T.I.S. Air Supply Line Diagram.....	FP-23
FO-13. M939/A1/A2 ABS Electrical System Wiring Diagram.....	FP-25
FO-14. ABS Air Tubing Installation Diagram.....	FP-27

Index

HOW TO USE THIS MANUAL

WARNINGS, CAUTIONS, AND NOTES

Read all WARNINGS, CAUTIONS, and NOTES before performing any procedure.

Warnings, cautions, notes, subject headings, and other essential information is printed in **BOLD** type, making them easier for the user to see.

GENERAL INFORMATION

This manual is divided into CHAPTERS and WORK PACKAGES. For a specific Chapter or Work Package, refer to the TABLE OF CONTENTS.

VOLUME 1

- The TABLE OF CONTENTS lists the titles of each Chapter and Work Package.
- CHAPTER 1 provides general information, equipment description, and theory of operation.
- CHAPTER 2 provides general troubleshooting procedures.
- CHAPTER 3 provides the CTIS troubleshooting procedures.

VOLUME 2

- CHAPTER 4 provides the ABS troubleshooting procedures.
- CHAPTER 5 provides the STE/ICE troubleshooting procedures.
- CHAPTER 6 provides PMCS maintenance instructions.
- CHAPTER 7 provides maintenance instructions.

VOLUME 3

- CHAPTER 8 provides maintenance instructions.

VOLUME 4

- CHAPTER 9 provides maintenance instructions.

VOLUME 5

- CHAPTER 10 provides maintenance instructions.
- CHAPTER 11 provides supporting information. The supporting information includes tables listing **References** used in this manual, an **Introduction to the Standard Two-level MAC**, the **Two-level MAC**, a listing of **Expendable and Durable Items**, a **Tool Identification** list, and a **Mandatory Replacement Parts** list.

The illustrations throughout this manual contain numerical callouts pointing to various components mentioned in the procedural steps. Mandatory replacement parts must be discarded after removal and replaced with a new part, which is listed in the Materials/Parts section located at the beginning of the task.

Prior to performing any maintenance functions on the 5-ton, 6x6, M939, M939A1, and M939A2 Diesel Truck series, **ALWAYS** do the following:

- Read and follow all WARNINGS in all work packages.
- Read the Safety Summary.
- Read the Equipment Description and Data located in Chapter 1.
- Read completely through the maintenance procedure to familiarize yourself with the procedure and the affected parts before beginning work.

Troubleshooting section is setup by either how a physical problem is occurring or how an active or stored trouble code is read from a diagnostic tool. By following a prescribed flow path through making decisions will lead you to a solution to remedy the problem. RPSTL manual, TM 9-2320-272-24P, is to be used in conjunction with this manual to help find needed parts for procurement. RPSTL manual lists and authorized spares and repair parts; special tools, special Test, Measurement, and Diagnostic Equipment (TMDE); and other special support equipment required for performance of Field Maintenance on the 5-ton, 6x6, M939, M939A1, and M939A2 Diesel Truck series. It authorizes

HOW TO USE THIS MANUAL - Continued

GENERAL INFORMATION - Continued

the requisitioning, issue, and disposition of spares, repair parts, and special tools as indicated by the Source, Maintenance, and Recoverability (SMR) codes.

METRIC SYSTEM

The equipment described herein contains metric components and requires metric, common, and special tools. Therefore, metric units and English units will be used throughout this publication. An English-to-Metric conversion table is included as the last page of this manual inside the back cover.

CHAPTER 1

**GENERAL INFORMATION, EQUIPMENT DESCRIPTION, AND
THEORY OF OPERATION**

FIELD MAINTENANCE GENERAL INFORMATION

SCOPE

This manual contains field level instructions for maintenance and troubleshooting of the 5-ton, 6x6, M939, M939A1, and M939A2 Diesel Truck Series. The vehicle is used for general cargo and troop transport, hauling and dumping, hauling semitrailers, and base station for electronics, maintenance, supply, and power.

MAINTENANCE FORMS, RECORDS, AND REPORTS

Department of the Army forms and procedures used for equipment maintenance will be those prescribed by DA PAM 750-8, The Army Maintenance Management System (TAMMS) Users Manual; or AR 700-138, Army Logistics Readiness and Sustainability. Maintenance forms and records used by Air Force personnel are prescribed in AFI 21-101 and the applicable TO 00-20 Series Technical Orders.

REPORTING EQUIPMENT IMPROVEMENT RECOMMENDATIONS (EIR)

If your M939 needs improvement, let us know. Send us an EIR. You, the user, are the only one who can tell us what you do not like about your equipment. Let us know why you do not like the design or performance.

For ALL non-Aviation/Missile EIR and PQDRs must be submitted through the Product Data Reporting and Evaluation Program (PDREP) Web site. The PDREP site is: <http://www.pdrep.csd.disa.mil/>.

If you do not have Internet access, you may submit your information using an SF 368 (Product Quality Deficiency Report). You can send your SF 368 using email, regular mail, or fax using the addresses/fax numbers specified in DA PAM 750-8, The Army Maintenance Management System (TAMMS) Users Manual.

We will send you a reply.

CORROSION PREVENTION AND CONTROL (CPC)

Corrosion Prevention and Control (CPC) of Army materiel is a continuing concern. It is important that any corrosion problems with this item be reported so that the problem can be corrected and improvements can be made to prevent the problem in future items.

Corrosion specifically occurs with metals. It is an electrochemical process that causes the degradation of metals. It is commonly caused by exposure to moisture, acids, bases, or salts. An example is the rusting of iron. Corrosion damage in metals can be seen, depending on the metal, as tarnishing, pitting, fogging, surface residue, and/or cracking.

SF Form 368, Product Quality Deficiency Report should be submitted to the address specified in DA PAM 750-8, The Army Maintenance Management System (TAMMS) Users Manual.

DESTRUCTION OF ARMY MATERIEL TO PREVENT ENEMY USE

For procedures to destroy the vehicle to prevent its use by the enemy, refer to TM 750-244-6, Procedures for Destruction of Tank-Automotive Equipment To Prevent Enemy Use.

PREPARATION FOR STORAGE OR SHIPMENT

For shipment procedures for the vehicle, refer to TM 9-2320-272-10, Preparation for Shipment.

Additional information can be found in TM 740-90-1, Marking, Packing, and Shipment of Supplies and Equipment: General Packing Instructions for Field Use.

Special requirements for shipment of vehicle:

- Temperature limits: None
- Pressure limits: None
- Power source required during shipment: None
- Humidity control: None
- Shock and vibration requirements: None
- Any other shipping requirements: None

Hazardous Materials:

Table 1. Hazardous Materials.

Shipping Name	Explosive Weight	Venting Requirement	Grounding Requirement	Other Requirement
Diesel Fuel	NA	None	None	NA
Lubricating Oil	NA	None	None	NA
Engine Coolant	NA	None	None	NA
Dry Chemical Fire Extinguisher	NA	None	None	NA
Lead Acid Batteries	NA	None	None	NA
Refrigerant R134A	NA	None	None	NA

LIST OF ABBREVIATIONS AND ACRONYMS

Table 2. List of Abbreviations/Acronyms.

Abbreviation	Definition
AOAP	Army Oil Analysis Program
CAGEC	Commercial and Government Entity Code
CARC	Chemical Agent Resistant Coating
cm	Centimeter
CPC	Corrosion Prevention and Control
CTIS	Central Tire Inflation System
cu-ft	Cubic Feet
cu-yd	Cubic Yard
cuM	Cubic Meter
EA	Each
EIR	Equipment Improvement Recommendations
ft	Feet/Foot
GAA	Grease, Automotive and Artillery
GMTK	General Mechanic's Tool Kit
GTW	Gross Towed Weight
gal	Gallon
I.D.	Inside Diameter
in.	Inch
kg	Kilogram
km	Kilometer
km/L	Kilometer Per Liter
kPa	KiloPascal
L	Left
l	Liter

LIST OF ABBREVIATIONS AND ACRONYMS - Continued

Table 2. List of Abbreviations/Acronyms - Continued.

Abbreviation	Definition
lb	Pound
lb-ft	Pound-Feet
MAC	Maintenance Allocation Chart
mm	Millimeter
mi	Mile
mpg	Miles Per Gallon
mph	Miles Per Hour
MTOE	Modified Table of Organization and Equipment
N·m	Newton meter
NATO	North Atlantic Treaty Organization
NBC	Nuclear, Biological, or Chemical
NSN	National Stock Number
O.D.	Outside Diameter
OE/HDO	Oil, Engine/Heavy Duty Oil
PMCS	Preventive Maintenance Checks and Services
POL	Petroleum, Oils, and Lubricants
psi	Pounds Per Square Inch
pt	Pint
PTO	Power Takeoff
qt	Quart
R	Right
rpm	Revolutions Per Minute
RPSTL	Repair Parts and Special Tools List
SMR	Source, Maintenance, and Recoverability

LIST OF ABBREVIATIONS AND ACRONYMS - Continued*Table 2. List of Abbreviations/Acronyms - Continued.*

Abbreviation	Definition
STE/ICE	Simplified Test Equipment for Internal Combustion Engine
TAMMS	The Army Maintenance Management System
TM	Technical Manual
TMDE	Test, Measurement, and Diagnostic Equipment
U/I	Unit of Issue
WP	Work Package
W/W	With Winch
WO/W	Without Winch
XLWB	Extra Long Wheelbase

QUALITY OF MATERIAL

Material used for replacement, repair, or modification must meet the requirements of this manual (TM 9-2320-272-23). If quality of material requirements are not stated in this maintenance manual, the material must meet the requirements of the drawings, standards, specifications, or approved engineering change proposals applicable to the vehicle.

COMMON TOOLS AND EQUIPMENT

Common tools and equipment are issued to field level maintenance personnel for maintaining vehicles. The General Mechanic's Tool Kit (GMTK) is required for all maintenance tasks. Common tools and equipment should not be used for purposes other than those prescribed and should be properly stored when not in use. For authorized common tools and equipment, refer to Modified Table of Organization and Equipment (MTOE), CTA 50-970.

SPECIAL TOOLS, TMDE, AND SUPPORT EQUIPMENT

The Maintenance Allocation Chart (MAC) identifies the authority and responsibility for maintenance tasks listed in this manual. Tool kits, test equipment, and diagnostic equipment required to perform maintenance tasks listed in the MAC. The Repair Parts and Special Tools List (RPSTL), TM 9-2320-272-24P, lists special tools and equipment required to perform maintenance procedures in this manual.

END OF WORK PACKAGE

FIELD MAINTENANCE EQUIPMENT DESCRIPTION AND DATA

EQUIPMENT CHARACTERISTICS, CAPABILITIES, AND FEATURES

The M939, M939A1, and M939A2 (M939/A1/A2) series of vehicles are varied in design and capabilities. The M939 was a redesign and retrofit of the M809 series of vehicles, providing enhanced capabilities.

The leading features of the M939 are:

- Automatic transmission (Allison MT654)
- Hydraulic-assisted power steering system
- Complete airbrake system
- Improved cooling system
- Three-crewmember cab
- Tilt hood

Changes were incorporated into later production engines (after engine serial number 11246663) which provided for control of exhaust gas recirculation back to the air intake manifold and the use of top-stop injectors to make up a clean air configuration.

The M939A1 improved on the M939 by adding 14:00xR20 super-sized tires, increasing the minimum road clearance and approach and departure angle. This necessitated a modification to the spare tire rack and lifting device used on all series vehicles.

The M939A2 incorporated a new engine (Cummins 6CTA8.3) and the Central Tire Inflation System (CTIS).

The M939/A1/A2 series vehicles can be distinguished from the M809 series by the following features:

On the left side, the exhaust was moved behind the cab and tilted out so exhaust gases clear the side of the vehicle. Hood latches were installed on the sides of the hood near the mirrors. The battery box was incorporated into the companion seat to improve battery life in cold climates. A steering-assist cylinder was installed between the right front frame rail and the right axle hub.

From the front, the hood and fenders are an assembly which tilt forward for access to the engine compartment. A tilt handle and locking device was installed to tilt and hold the hood in a secured open position.

The air filter was moved under the driver's door and the intake stack was brought up behind the cab, even with the cab top.

Cargo Trucks With Dropsides: M923/A1/A2 WO/W and M925/A1/A2 W/W. These vehicles are used to transport cargo and troops. The vehicles have a payload rating of 10,000 lbs (4,540 kg) and provide 550 cu-ft (15.4 cuM) of cargo space. Removable dropsides and tailgate permit hauling of extra wide loads and easy access for unloading cargo. Troop seats, bows, and canvas are also available. The M925/A1/A2 models have front winches and can be used for recovery operation. The bed of the M923A1/A2 and M925A1/A2 has been shifted back to facilitate a new lifting davit and spare tire mount. When the tire is mounted in its storage location on the M923A1/A2 and M925A1/A2, the top of the tire extends above the minimal reducible height and may need to be removed to obtain the necessary measurement.

EQUIPMENT CHARACTERISTICS, CAPABILITIES, AND FEATURES - Continued

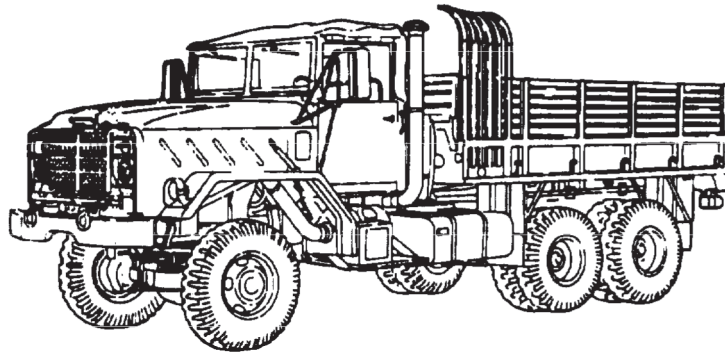

M923

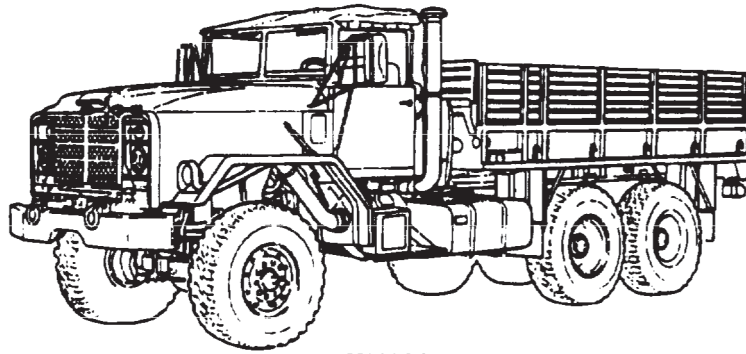

M923A1

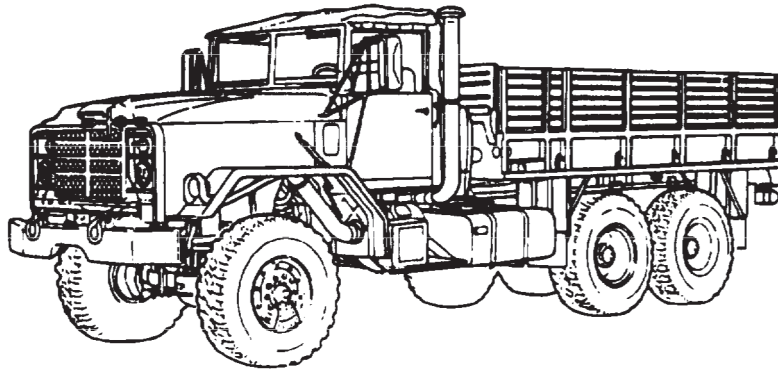

M923A2

G0001DAA

Figure 1. M923 Cargo Truck.

EQUIPMENT CHARACTERISTICS, CAPABILITIES, AND FEATURES - Continued

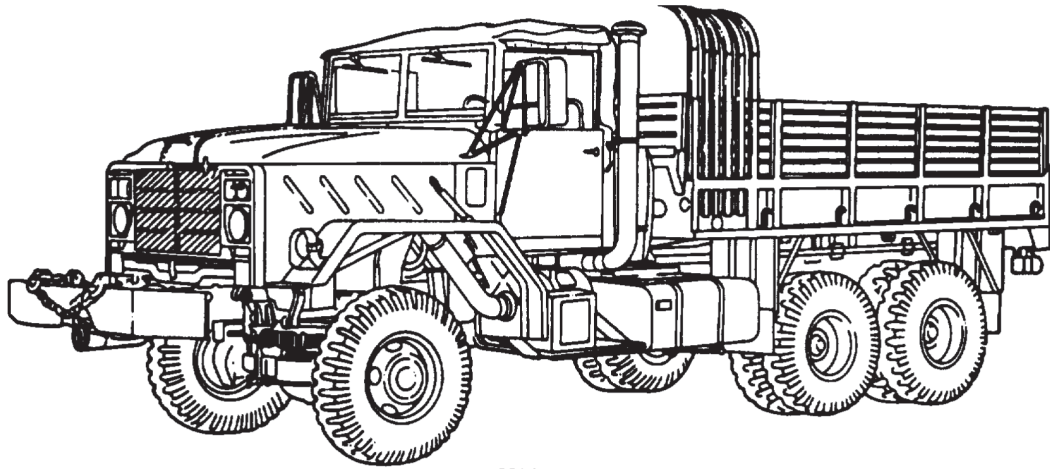

M925

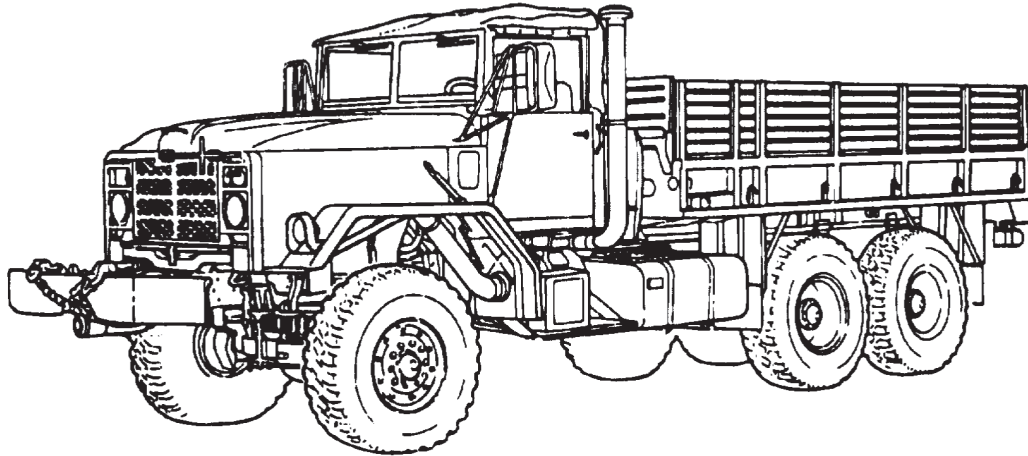

M925A1

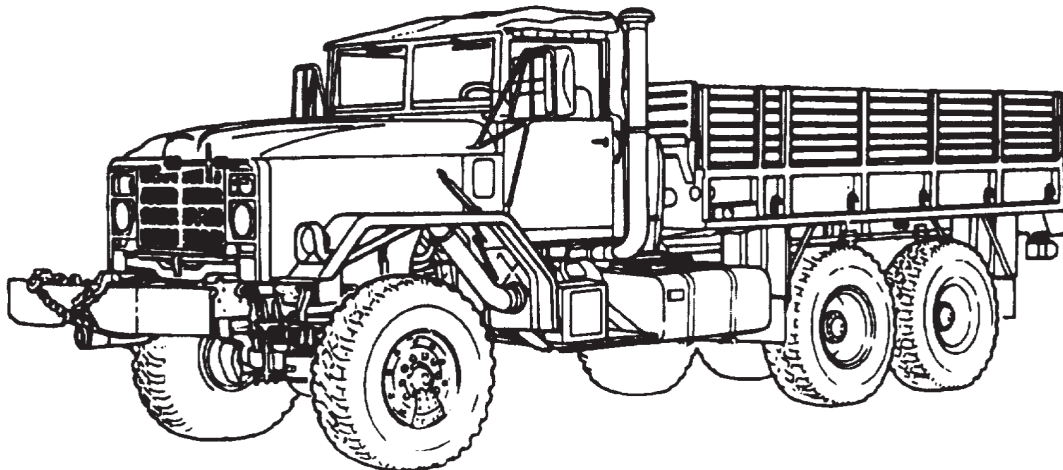

M925A2

G0002DAA

Figure 2. M925 Cargo Truck.

EQUIPMENT CHARACTERISTICS, CAPABILITIES, AND FEATURES - Continued

Cargo Truck With Extra Long Wheelbase (XLWB): M927/A1/A2 WO/W and M928/A1/A2 W/W. These vehicles are used to transport troops and longer cargo loads. They have the same characteristics as the M923/A1/A2 and M925/A1/A2, but have additional 76 in. (193 cm) of bed space that allows an extra 194 cu-ft (5.4 cuM) of cargo space. Troop seats, bow, and tarpaulin are available. This vehicle has permanent steel-welded sides. The M928A1/A2 model vehicles have winches and can be used for recovery operations. The bed of the M923A1/A2 and M925A1/A2 has been shifted back to facilitate a new lifting davit and spare tire mount. When the tire is mounted in its storage location on the M923A1/A2 and M925A1/A2, the top of the tire extends above the minimal reducible height and may need to be removed to obtain the necessary measurement.

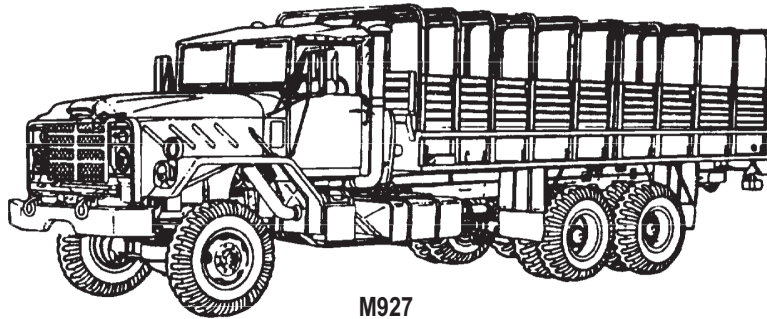

M927

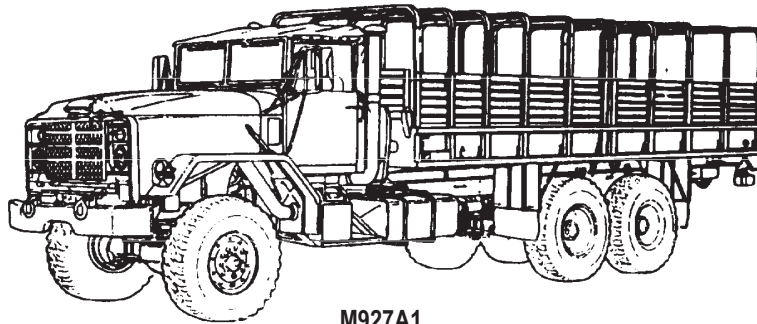

M927A1

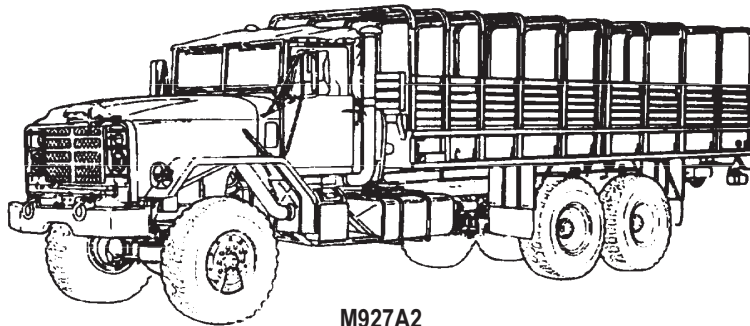

M927A2

G0003DAA

Figure 3. M927 Extra Long Wheelbase Cargo Truck.

EQUIPMENT CHARACTERISTICS, CAPABILITIES, AND FEATURES - Continued

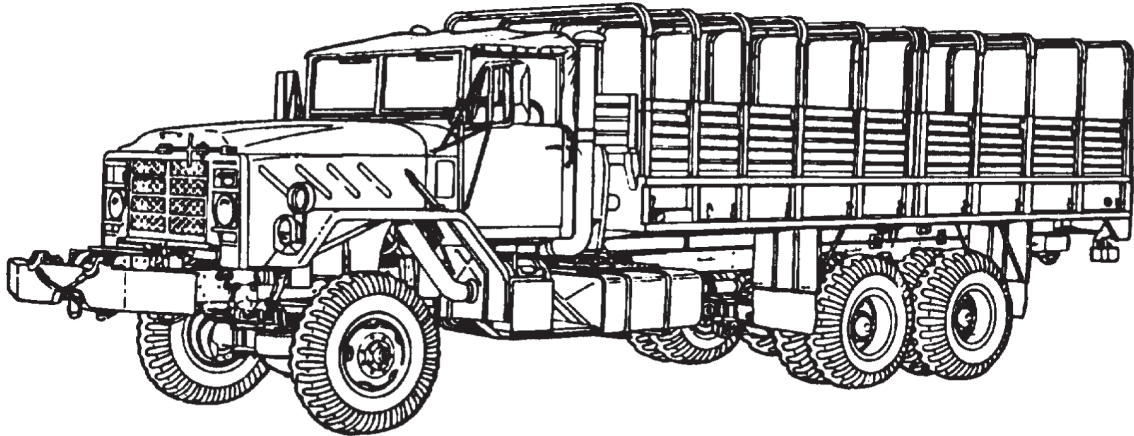

M928

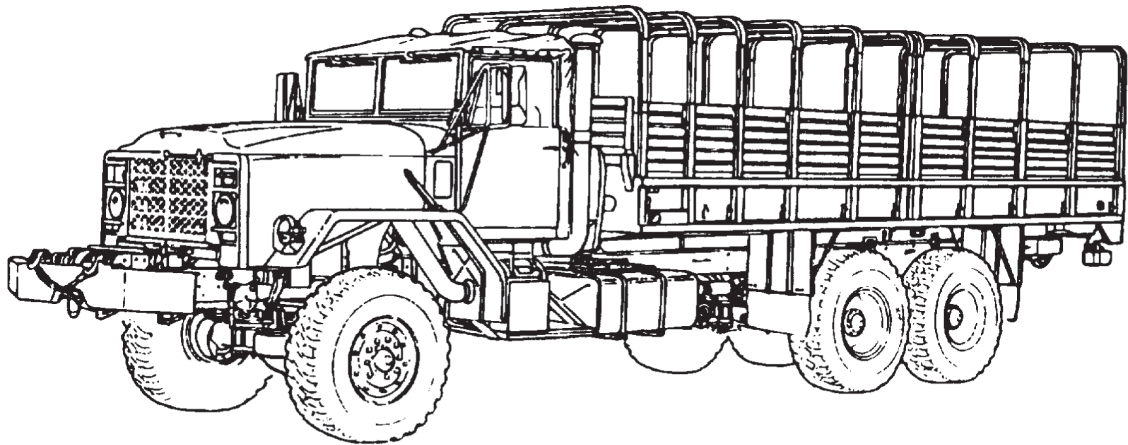

M928A1

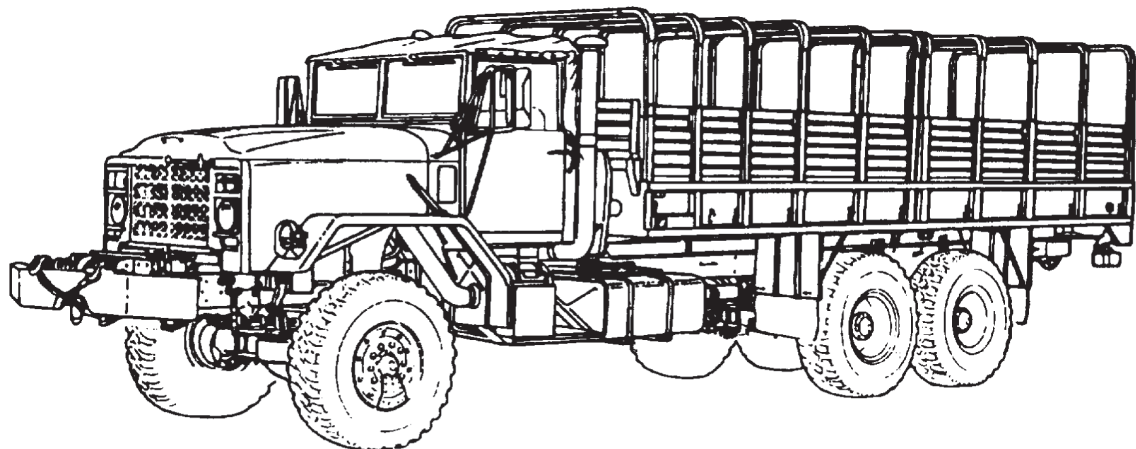

M928A2

G0004DAA

Figure 4. M928 Extra Long Wheelbase Cargo Truck.

EQUIPMENT CHARACTERISTICS, CAPABILITIES, AND FEATURES - Continued

Dump Truck: M929/A1/A2 WO/W and M930/A1/A2 W/W. These vehicles are for hauling and dumping cargo. They have a capacity of 5 cu-yd (3.84 cuM). The bodies have provisions for side racks and troop seats, and bow and tarpaulin for troop transport. The M930/A1/A2 have front winches and can be used for recovery operations. Additional support brackets have been designed on the M929A1/A2 and M930A1/A2 model vehicles and are available to support the bed in a slightly raised position for removal of the 14:00xR20 spare tire.

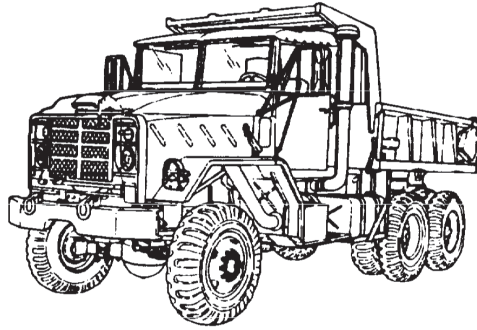

M929

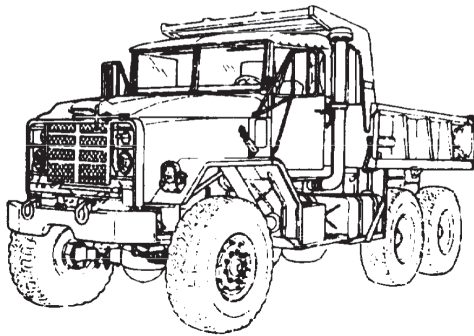

M929A1

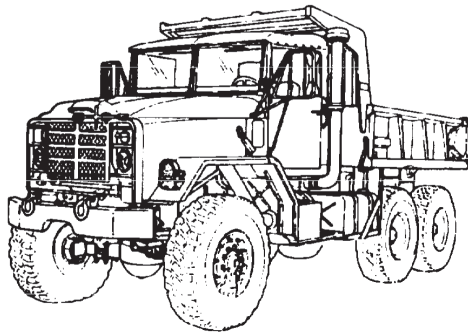

M929A2

G0005DAA

Figure 5. M929 Dump Truck.

EQUIPMENT CHARACTERISTICS, CAPABILITIES, AND FEATURES - Continued

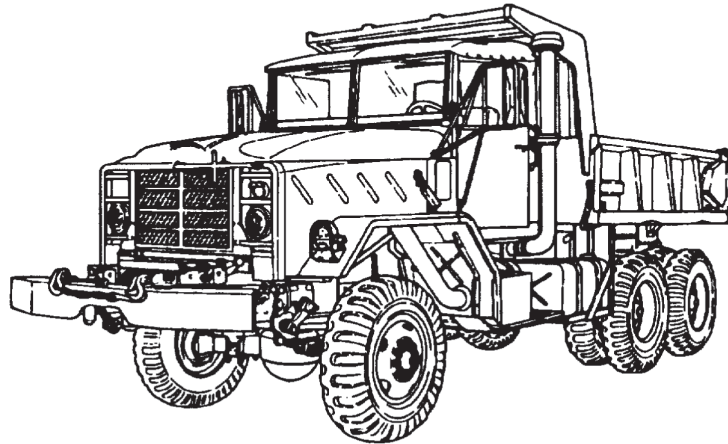

M930

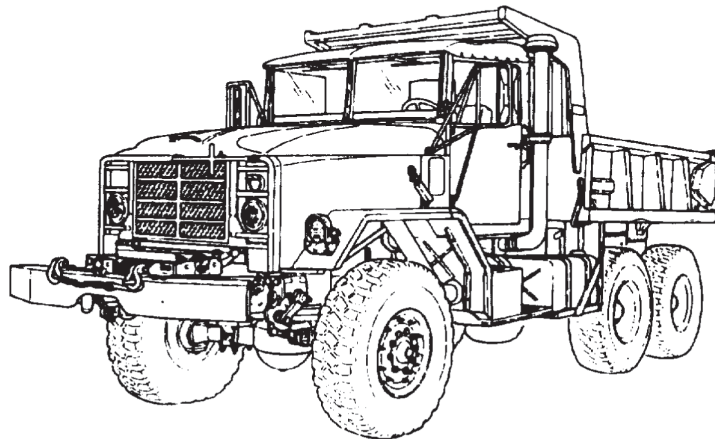

M930A1

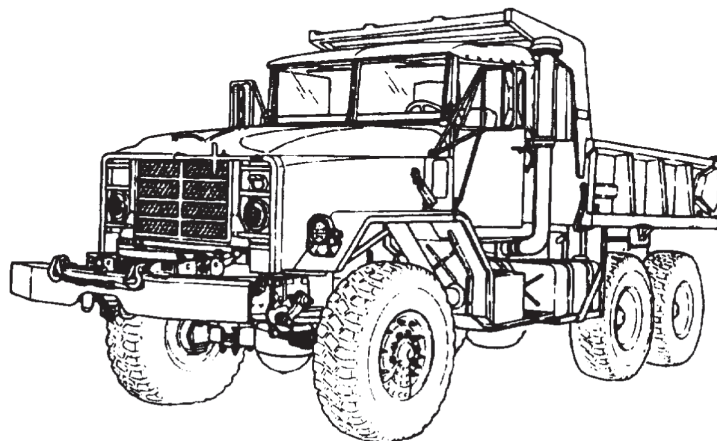

M930A2

G0006DAA

Figure 6. M930 Dump Truck.

EQUIPMENT CHARACTERISTICS, CAPABILITIES, AND FEATURES - Continued

Tractor Trucks: M931/A1/A2 WO/W and M932/A1/A2 W/W. These vehicles are equipped with a fifth wheel and are used for hauling semitrailers. The fifth wheel is capable of pivoting 21 degrees up, 15 degrees down, or 7 degrees sideways. The M932/A1/A2 model vehicles have front winches and can be used for recovery operations.

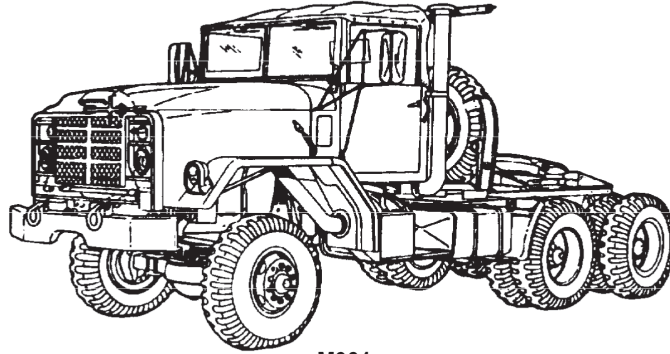

M931

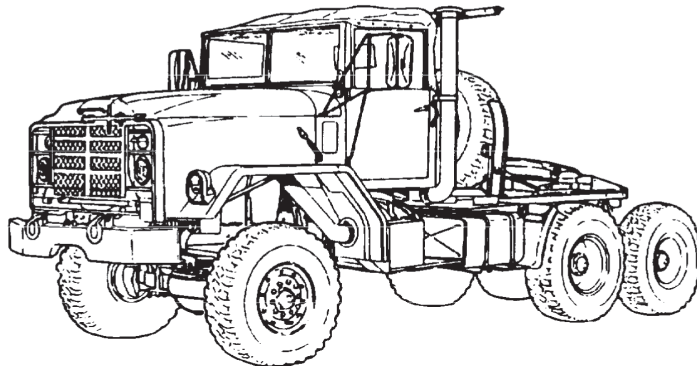

M931A1

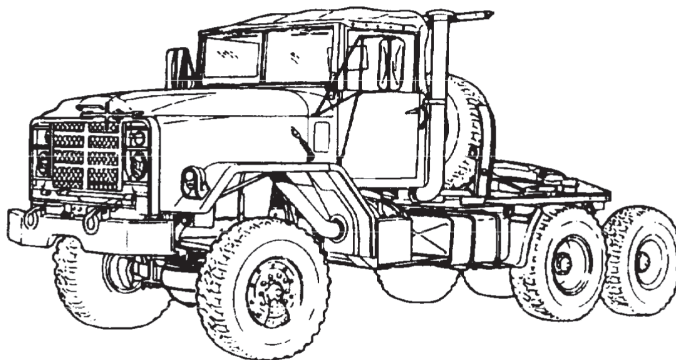

M931A2

G0007DAA

Figure 7. M931 Tractor Truck.

EQUIPMENT CHARACTERISTICS, CAPABILITIES, AND FEATURES - Continued

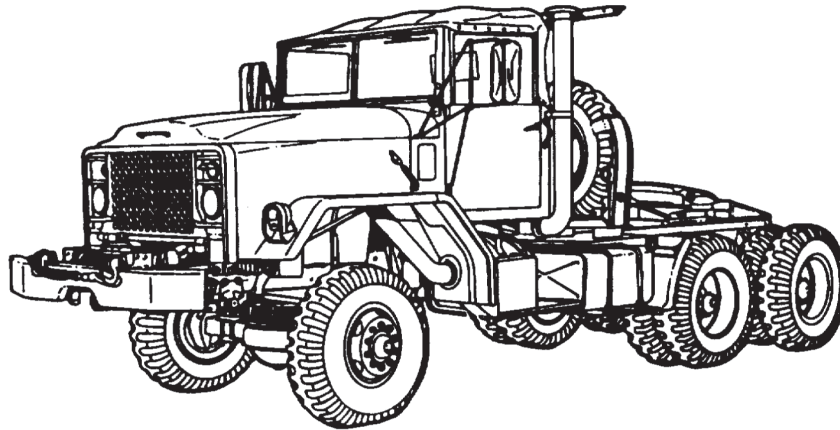

M932

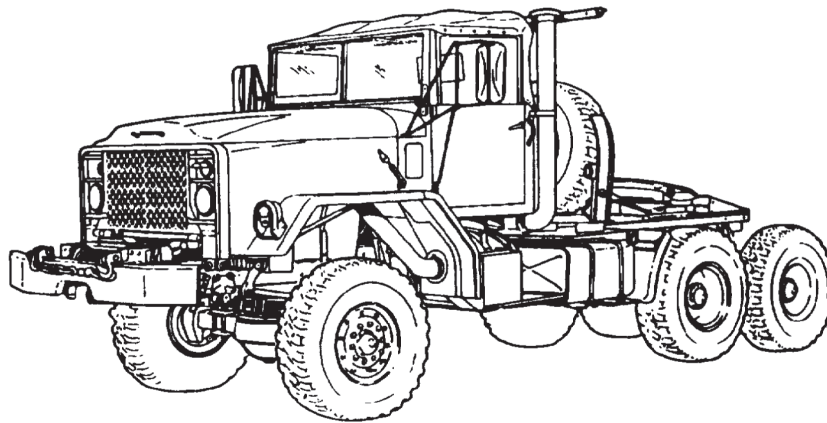

M932A1

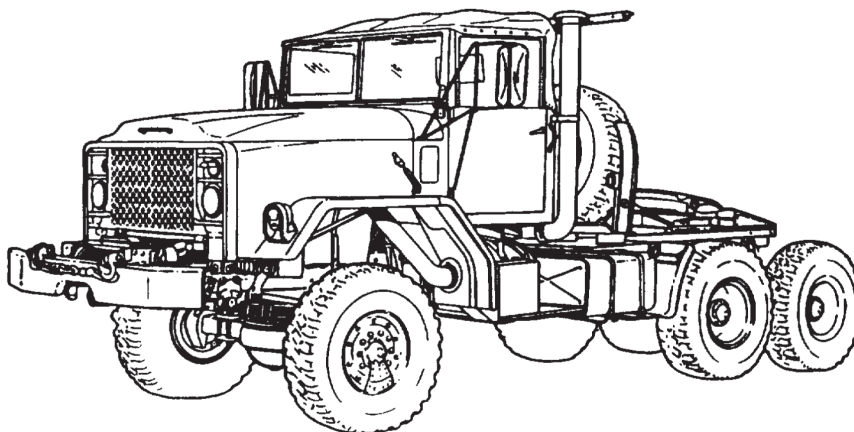

M932A2

G0008DAA

Figure 8. M932 Tractor Truck.

EQUIPMENT CHARACTERISTICS, CAPABILITIES, AND FEATURES - Continued

Expansible Vans: M934/A1/A2. These vehicles are used for electronics, maintenance, supply, power, and base station operation. The van body can be expanded when set up in a stationary mode of operation; when mission requires more mobile-type operation, the body is left in the retracted position.

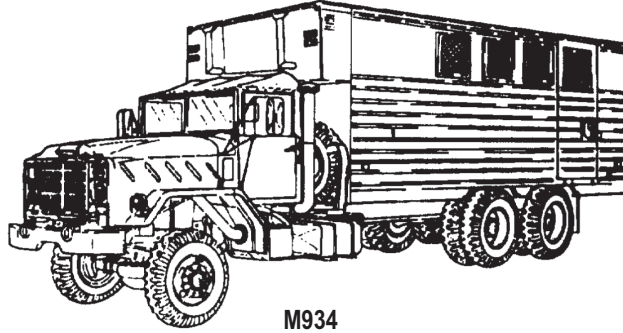

M934

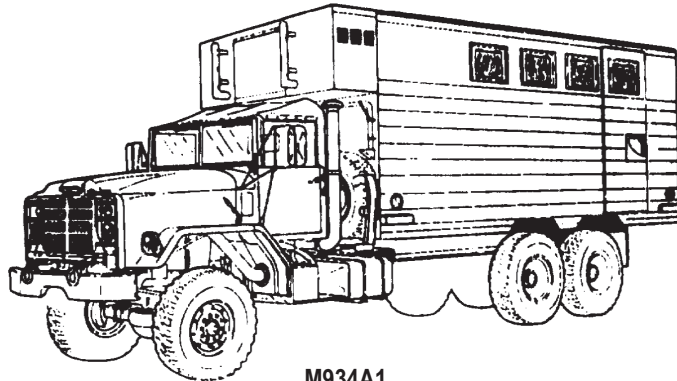

M934A1

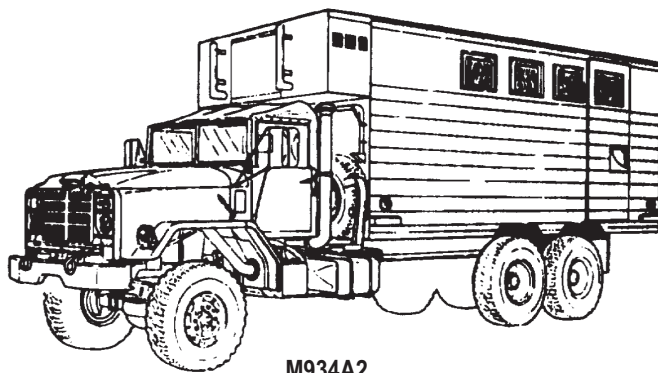

M934A2

G0009DAA

Figure 9. M934 Expansible Vans.

EQUIPMENT CHARACTERISTICS, CAPABILITIES, AND FEATURES - Continued

Medium Wrecker: M936/A1/A2. These vehicles are used for wrecker and salvage operations. They have a revolving hydraulic crane with a self-supported extendable boom. Boom-to-ground supports and outriggers are provided. Crane lifting capacity is 20,000 lb (9,080 kg). The vehicle has a front winch with a 20,000 lb (9,080 kg) capacity. M936/A1 models are equipped with front anchor brackets for heavy straight and side pulls using the front winch. All models are equipped with a 45,000 lb (20,250 kg) capacity rear winch, rear anchor brackets for heavy straight and side pulls, and spring brake override of the Power Takeoff (PTO) air switch for self-recovery operations.

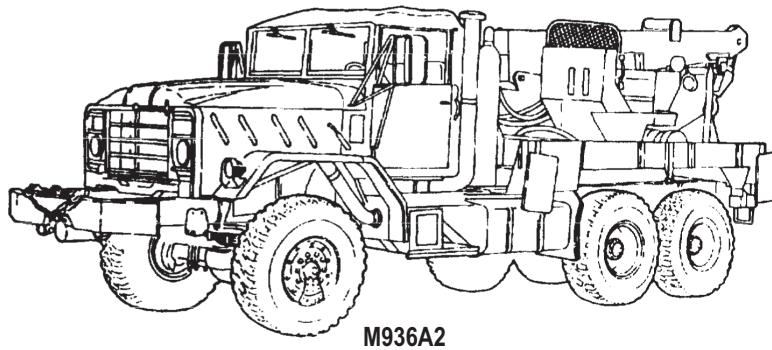
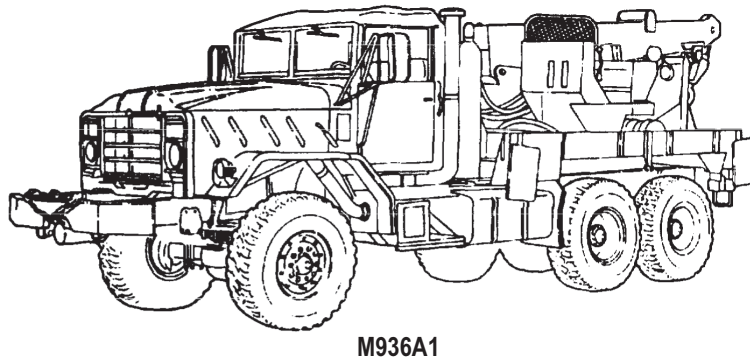
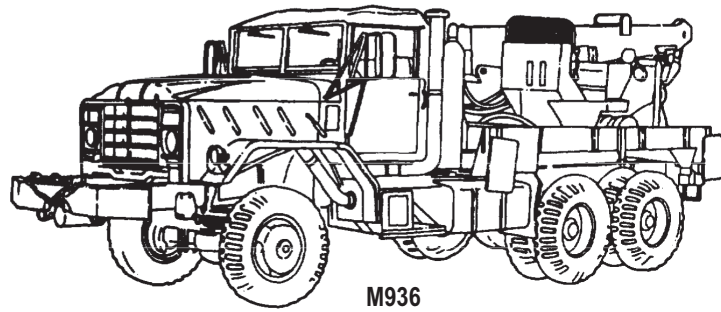

G0010DAA

Figure 10. M936 Medium Wreckers.

LOCATION AND DESCRIPTION OF MAJOR COMPONENTS

Exterior Components. The components described herein are common to most vehicles covered in this manual. Specific differences can be found in TM 9-2320-272-10 or in Table 3, Differences Between Models, of this manual.

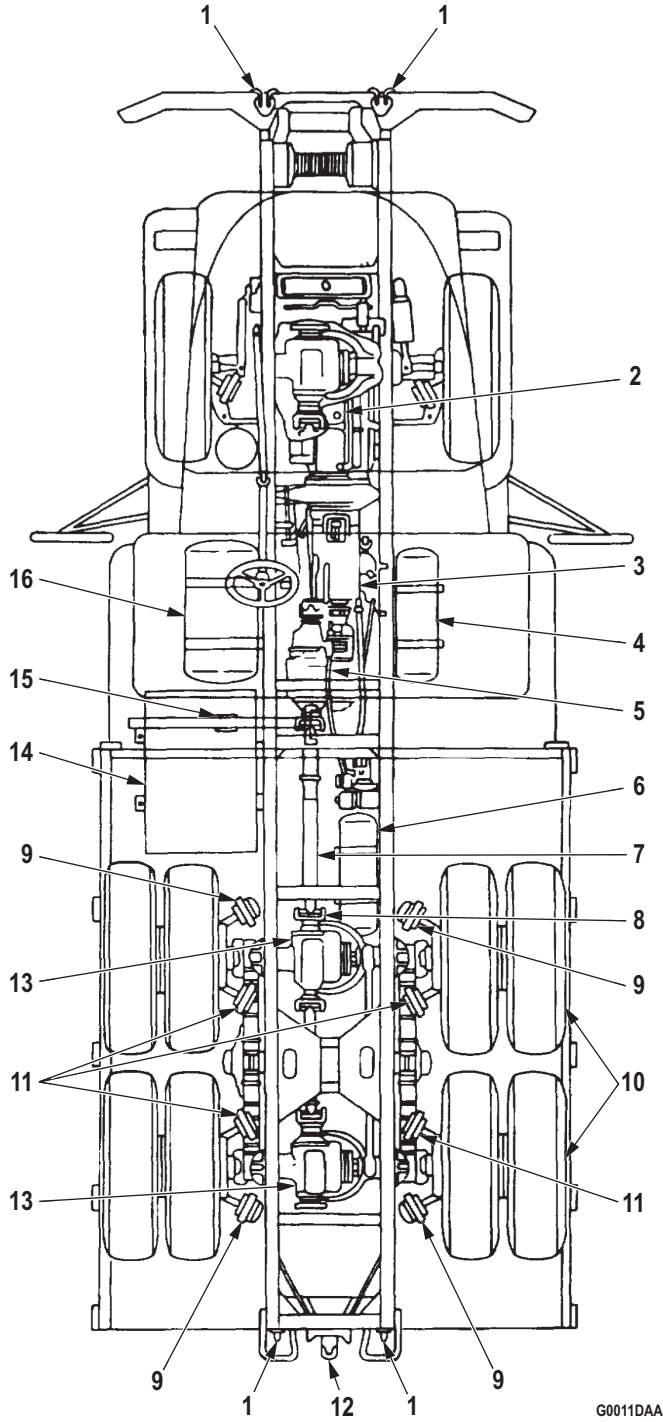

Figure 11. Location Of Exterior Major Components.

LOCATION AND DESCRIPTION OF MAJOR COMPONENTS - Continued

Table 1. Description of Exterior Major Components.

1	LIFTING SHACKLE(S) - Permit vehicle to be towed by another vehicle or used for tiedown attachment when transporting vehicle.
2	ENGINE - There are two different Cummins model engines used, the NHC 250 (M939/A1 series vehicles) and 6CTA8.3 diesel (M939A2 series vehicles), which provide mechanical power to the vehicle and engine-driven subsystems.
3	TRANSMISSION - The Allison MT654CR automatic, used on all M939/A1/A2 series vehicles, adapts the engine's output for a varying range of operating speeds.
4	PRIMARY AND SECONDARY AIR RESERVOIRS - Provides storage of compressed air and isolation between air subsystems.
5	TRANSFER CASE - Directs the engine and transmission output to the specified axles and/or auxiliary equipment.
6	WET TANK RESERVOIR - Provides reserve storage of compressed air created by the air compressor or external source when demand is low and releases it when required. This lessens the cycling of the engine-driven air compressor.
7	REAR PROPELLER SHAFT(S) - Transmits power between transfer case and forward-rear axle assemblies, and between forward-rear and rear-rear axle assemblies.
8	UNIVERSAL JOINT(S) - Provides a flexible point between a component and the propeller shafts. This allows components that cannot maintain precision alignment to transfer power from one point to another, without undue stress or breakage.
9	SERVICE BRAKE CHAMBER - Mechanical brake actuator that is activated by applying air pressure to an expandable cylinder, causing it to apply braking force to the brake drum.
10	REAR BOGIE - The suspension system comprised of both rear axles, upper and lower torque rods, springs, and seats that support the rear vehicle weight.
11	SPRING BRAKE CHAMBER - Mechanical brake actuator that is spring-loaded to apply brakes when air is low or not present. During normal vehicle operation, air piston counteracts the spring tension and allows the brakes to release. Spring brakes can be bypassed by pushing in the spring brake VERRIDE switch on the instrument panel, or released using procedures found in TM 9-2320-272-10.
12	TOWING PINTLE - Provides a secure quick-connect/disconnect for towing vehicles or equipment.
13	REAR DIFFERENTIAL(S) - Bi-directionally transfer power from the propeller shafts to the axles, and provide a straight-through connection to power additional propeller shafts.
14	FUEL TANK(S) - Provides storage of fuel.

LOCATION AND DESCRIPTION OF MAJOR COMPONENTS - Continued

Table 1. Description of Exterior Major Components - Continued.

15	<p>SPARE TIRE CARRIER - Stores spare tire.</p> <ul style="list-style-type: none"> • Davit - Used to load and unload spare tire on M923/A1/A2, M925/A1/A2, M927/A1/A2, M928/A1/A2, M931/A1/A2, and M9321/A1/A2 model vehicles. • Winch and Swinging Davit - Used to load and unload spare tire of M934/A1/A2 model vehicles. Optional kit is available for M934 model vehicle. • Hoist and Lifting Eye - Used to load and unload spare tire on M929/A1/A2, M930/A1/A2, and M943 model vehicles. Optional kit is available to support dump bed in semi-raised position during tire removal. • Vehicle Crane - Used to load and unload spare tire on M936/A1/A2 model vehicles. NOTE: On M936/A1/A2 model vehicles, remove spare tire prior to changing tire, and install tire in spare tire carrier after tire change is complete. Operation of crane and/or vehicle engine while vehicle is on jacks may cause the vehicle to slip off jack.
16	<p>AIR CLEANER - Filters air before it enters the intake manifold or turbocharger and collects dust in removable section of filter canister.</p>

LOCATION AND DESCRIPTION OF MAJOR COMPONENTS - Continued

Interior Cab Components. The components described herein are common to one or more vehicles covered in this manual. Components not found here can be found in TM 9-2320-272-10 or in Table 3, Differences Between Models, of this manual.

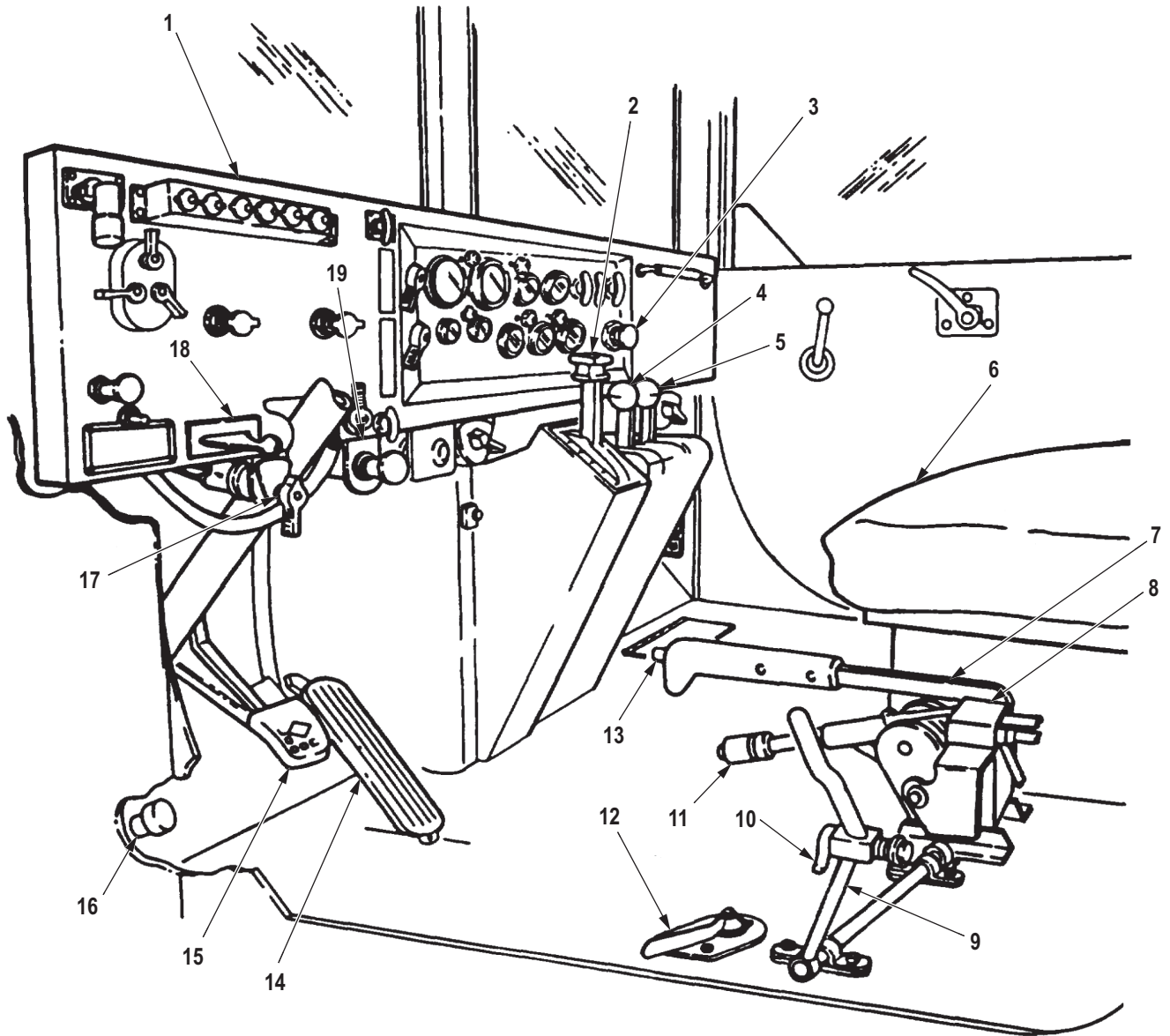

G0012DAA

Figure 12. Description of Interior Cab Components.

LOCATION AND DESCRIPTION OF MAJOR COMPONENTS - Continued

Table 2. Description of Interior Cab Components.

1	INSTRUMENT PANEL - Houses controls and indicators.
2	TRANSMISSION SELECTOR LEVER - Manual control to select driving gear.
3	SPRING BRAKE OVERRIDE SWITCH - Pressed in to release spring brakes independent of the mechanical parking brake for tests and adjustments. Can be used to release spring brakes in the event a leak or stoppage occurs in lines between primary and spring brake reservoirs, or primary system air shutoff valve is closed.
4	TRANSMISSION POWER TAKEOFF (PTO) LEVER - Used on M925/A1/A2, M928/A1/A2, M929/A1/A2, M930/A1/A2, M932/A1/A2, and M936/A1/A2 model vehicles only. Provides hydraulic power for front winch and/or dump body operation.
5	WINCH CONTROL LEVER - Provides control of winch unwinding and winding operations from inside the cab.
6	PASSENGER SEAT - Combination two-person crew seat, battery box, and storage box. Seats are equipped with two sets of seatbelts, the battery box houses four batteries, and the storage compartment stores technical manuals. NOTE: Ensure companion seatbelts are not caught inside battery box.
7	TRANSFER CASE SHIFT LEVER - Pushed down to shift transfer case into HIGH gear, center position for NEUTRAL, and up position for LOW gear. When transfer case is placed in LOW, it will automatically engage six-wheel drive. In HIGH, the instrument panel-mounted front-wheel drive lock-in switch must be used to achieve six-wheel drive operation.
8	SPRING BRAKE CONTROL SWITCH - Senses the position of the parking brake control lever and signals the spring brakes to engage when the lever is up and disengage when it is down. Spring brakes can be tested independently from parking brake by raising this switch without pulling up the parking brake control lever (TM 9-2320-272-10).
9	(a) DUMP BODY CONTROL LEVER - Used on M929/A1/A2 and M930/A1/A2 to control raising (pulled back) and lowering (pushed forward) of dump body. (b) TRANSFER CASE POWER TAKEOFF (PTO) - Used on M936/A1/A2 to control the hydraulic pump that delivers hydraulic pressure to the rear winch and crane. A spring brake air dump switch is installed on the lever when used on these vehicles, which engages the spring brakes. To override this feature during self-recovery operation with the rear winch, the driver must depress and hold the PTO spring brake override air switch on the instrument panel.
10	DUMP BODY CONTROL LEVER SAFETY LATCH - Secures dump body control lever or transfer case PTO in NEUTRAL when not in use.
11	PARKING BRAKE CONTROL LEVER - Pulled up to set mechanical brake on output of transfer case and to engage the spring brakes, and down to disengage the brakes. Knob on top of handle is turned clockwise to increase braking action on the output of transfer case, and counterclockwise to decrease braking action. Spring brakes engagement is controlled by the spring brake control switch located on the back of the lever.

LOCATION AND DESCRIPTION OF MAJOR COMPONENTS - Continued

Table 2. Description of Interior Cab Components - Continued.

12	FUEL TANK SELECTOR LEVER - Used on dual tank model vehicles only. NOTE: Tanks must be switched periodically to lessen the buildup of contaminants and fungus.
13	TRANSFER CASE SHIFT LEVER SWITCH - Used in conjunction with transmission selector lever in NEUTRAL position to allow transfer case to be shifted between HIGH and LOW gears.
14	ACCELERATOR PEDAL - Foot control to vary the speed of the engine.
15	BRAKE PEDAL - Applies the service brakes.
16	DIMMER SWITCH - Depressed to change between HIGH and LOW beam setting on headlights.
17	FUEL GAUGE TANK SELECTOR SWITCH - Used to switch fuel gauge to read either left or right fuel tank. Installed only on dual tank model vehicles.
18	FRONT-WHEEL DRIVE LOCK-IN SWITCH - A pneumatic switch that permits front-wheel drive to be engaged when the transfer case is in HIGH position. Operation of switch is not required when transfer case is in LOW position; system will automatically switch into six-wheel drive.
19	POWER TAKEOFF (PTO) SPRING BRAKE OVERRIDE SWITCH - Used during rear winch self-recovery operations of M936/A1/A2 model vehicles only. This air control switch must be held in to override spring brake air dump switch on transfer case PTO lever.

DIFFERENCES BETWEEN MODELS

Table 3. Differences Between Models.

EQUIPMENT/FUNCTION	VEHICLE
BODY TYPE	
Cargo Dropside	M923, M923A1, M923A2, M925, M925A1, M925A2
Cargo Fixed Side (XLWB)	M927, M927A1, M927A2, M928, M928A1, M928A2
Crane	M936, M936A1, M936A2
Dump	M929, M929A1, M929A2, M930, M930A1, M930A2
Tractor	M931, M931A1, M931A2, M932, M932A1, M932A2
Van	M934, M934A1, M934A2
CENTRAL TIRE INFLATION SYSTEM	M923A2, M925A2, M927A2, M928A2, M929A2, M930A2, M931A2, M932A2, M934A2, M936A2
FIELD CHOCKS AND ANCHORS	
Front	M936, M936A1

DIFFERENCES BETWEEN MODELS - Continued

Table 3. Differences Between Models - Continued.

EQUIPMENT/FUNCTION	VEHICLE
Rear	M936, M936A1, M936A2
FLOODLIGHTS	M936, M936A1, M936A2
FUEL TANKS	
Dual Tanks 116 gal (439.1 l)	M929, M929A1, M929A2, M930, M930A1, M930A2, M931, M931A1, M931A2, M932, M932A1, M932A2
Dual Tanks 139 gal (526.1 l)	M936, M936A1, M936A2
Single Tank 81 gal (306.6 l)	M923, M923A1, M923A2, M925, M925A1, M925A2, M927, M927A1, M927A2, M928, M928A1, M928A2, M934, M934A1, M934A2
HEAT/AIR CONDITIONED BODY OPERATIONS	
Cargo/Personnel	M923, M923A1, M923A2, M925, M925A1, M925A2, M927, M927A1, M927A2, M928, M928A1, M928A2, M929, M929A1, M929A2, M930, M930A1, M930A2, M934, M934A1, M934A2
Communications/Electronic Repair	M934, M934A1, M934A2
Dump	M929, M929A1, M929A2, M930, M930A1, M930A2
OPERATIONS	
Fifth Wheel	M931, M931A1, M931A2, M932, M932A1, M932A2
Wrecker	M936, M936A1, M936A2
TIRES	
11:00xR20	M923, M925, M927, M928, M929, M930, M931, M932, M934, M936
14:00xR20	M923A1, M923A2, M925A1, M925A2, M927A1, M927A2, M928A1, M928A2, M929A1, M929A2, M930A1, M930A2, M931A1, M931A2, M932A1, M932A2, M934A1, M934A2, M936A1, M936A2

DIFFERENCES BETWEEN MODELS - Continued

Table 3. Differences Between Models - Continued.

EQUIPMENT/FUNCTION	VEHICLE
WHEELBASES	
167 in. (424.2 cm)	M929, M929A1, M929A2, M930, M930A1, M930A2, M931, M931A1, M931A2, M932, M932A1, M932A2
179 in. (454.7 cm)	M923, M923A1, M923A2, M925, M925A1, M925A2, M936, M936A1, M936A2
215 in. (546.1 cm)	M927, M927A1, M927A2, M928, M928A1, M928A2, M934, M934A1, M934A2
WINCH	
Front	M925, M925A1, M925A2, M928, M928A1, M928A2, M930, M930A1, M930A2, M932, M932A1, M932A2, M936, M936A1, M936A2
Rear	M936, M936A1, M936A2

EQUIPMENT DATA

Vehicle performance data for the M939/A1/A2 series vehicles are listed in Table 4. Additional information and equipment service data are in TM 9-2320-272-10.

Table 4. Vehicle Performance Data.

PAYLOAD:	
Carried Weight: M923, M923A1, M923A2, M925, M925A1, M925A2, M927, M927A1, M927A2, M928, M928A1, M928A2, M929, M929A1, M929A2, M930, M930A1, M930A2	10,000 lb (4,540 kg)
M934, M934A1, M934A2	5,000 lb (2,270 kg)
M936, M936A1, M936A2	7,000 lb (3,178 kg)
Towed Load on Pintle: All (except M936, M936A1, M936A2)	15,000 lb (6,810 kg)
M936, M936A1, M936A2	20,000 lb (9,080 kg)
On Fifth Wheel: M929, M929A1, M929A2, M930, M930A1, M930A2	15,000 lb (6,810 kg)
Semitrailer GTW: M929, M929A1, M929A2, M930, M930A1, M930A2	37,500 lb (17,025 kg)

EQUIPMENT DATA - Continued

Table 4. Vehicle Performance Data - Continued.

CAPACITIES:	
Cooling System: All Models	47 qt (44.5 l)
Differentials (Each): All Models	12 qt (11.3 l)
Engine Crankcase Only: M939/A1 Series	23 qt (21.8 l)
M939A2 Series	18 qt (17.0 l)
Engine Crankcase and Filter: M939/A1 Series	27 qt (25.5 l)
M939A2 Series	20 qt (18.9 l)
Fuel Tank: M923, M923A1, M923A2, M925, M925A1, M925A2, M927, M927A1, M927A2, M928, M928A1, M928A2, M934, M934A1, M934A2 (Single Tank)	0.81 gal (306.6 l)
M936, M936A1, M936A2 Dual Tanks	139 gal (526.1 l)
M929, M929A1, M929A2, M930, M930A1, M930A2, M931, M931A1, M931A2, M932, M932A1, M932A2 (Dual Tanks)	116 gal (439.1 l)
Hydraulic Tank: M925, M925A1, M925A2, M928, M928A1, M928A2, M932, M932A1, M932A2	8 gal (30.3 l)
M929, M929A1, M929A2	5 gal (18.9 l)
M930, M930A1, M930A2	6.25 gal (23.7 l)
M936, M936A1, M936A2	100 gal (378.5 l)
Steering System: M939A1 Series (Ross)	5 qt (4.7 l)
M939A2 Series (Sheppard)	3 qt (2.83 l)
Transmission: All Models (w/o PTO)	17 qt (16.1 l)
All Models (w/PTO)	19 qt (18.0 l)

EQUIPMENT DATA - Continued

Table 4. Vehicle Performance Data - Continued.

All Models (w/o PTO and converter dry)	23 qt (22.1 l)
All Models (w/PTO and converter dry)	25 qt (23.7 l)
Transfer Case: All Models	6.25 gal (23.7 l)
Winch Gear Case (Front): All Models (W/W)	2.6 pt (1.2 l)
Winch Gear Case (Rear): M936, M936A1, M936A2	7 pt (3.3 l)
ENGINE	
M939/A1 Series Vehicles: Brake Horsepower	250 horsepower @ 2,100 rpm
Cylinders	6 (in-line)
Fuel Consumption	3 to 4 mpg (1.3 to 1.7 km/L)
Idle Speed (engine rpm)	600 to 650 rpm
Model	Cummins NHC 250
Mount (Front)	Trunnion
Mount (Rear)	Rubber biscuit
Oil Pressure at Idle	15 psi (103 kPa)
Operating Speed (engine rpm)	1,500 to 2,100 rpm
Type	Diesel, normally-aspirated, liquid-cooled
M939A2 Series Vehicles: Brake Horsepower	240 horsepower @ 2,100 rpm
Cylinders	6 (in-line)
Fuel Consumption	5.5 to 6.0 mpg (2.3 to 2.6 km/L)
Idle Speed	565 to 635 rpm
Model	Cummins 6CTA8.3
Mount (Front)	Trunnion

EQUIPMENT DATA - Continued

Table 4. Vehicle Performance Data - Continued.

Mount (Rear)	Rubber biscuit
Oil Pressure at Idle	10 psi (69 kPa)
Operating Speed (engine rpm)	2,100 rpm
Type	Diesel, liquid-cooled, turbocharged, after-cooled
COOLING SYSTEM	
M939/A1 Series Vehicles: Coolant Operating Temperature	175°F to 195°F (79°C to 91°C)
Fan, 6-blade	26 in. (660 mm)
Thermostat: Starts to Open	175°F (79°C)
Fully Open	185°F (85°C)
M939A2 Series Vehicles: Coolant Operating Temperature	190°F to 200°F (88°C to 93°C)
Fan, 7-blade	26.5 in. (673 mm)
Thermostat: Starts to Open	181°F (83°C)
Fully Open	203°F (95°C)
Radiator Type	Crossflow
Surge Tank Cap Pressure	14 psi (97 kPa)
ELECTRICAL SYSTEM	
Alternator: Ampere Output (maximum)	60 amp
Model	
Voltage Output	28 volts
Voltage Regulation	Mounted internal
Batteries: Model	6TN
Number Required	4

EQUIPMENT DATA - Continued

Table 4. Vehicle Performance Data - Continued.

Plates Per Cell	2 3
Specific Gravity Full Charge	0 70°F (@ 21°C)
Voltage	12 volts
Protective Control Box	WSU-4001-UT
Starter: Model	MES6401-CUT
Voltage	24 volts
TRANSMISSION (MT654CR)	
Drive Sequence	Reverse, Neutral, 1, 2, 3, 4, 5
Drive Range and Shift Control	Manual
Oil Pressure	26 psi (179.3 kPa)
Oil Type	OE/HDO-10
Oil Capacity: Drain and Refill	4.25 gal (16.1 l)
w/o PTO (dry)	5.75 gal (21.8 l)
w/PTO (dry)	6.25 gal (23.7 l)
Oil Temperature: Maximum	300°F (149°C)
Normal Operating Temperature	120°F to 220°F (49°C to 104°C)
Power Takeoff: Type	Converter-driven
Mounting Flange	One-opening, SAE, 6-bolt
TRANSFER CASE	
Model	T-1138
Type	Two-speed synchronized

EQUIPMENT DATA - Continued

The location and contents of caution, data, and warning plates are provided in TM 9-2320-272-10, and a complete list and location of all caution, data, warning, and identification plates is in TM 9-2320-272-24P. If any of these plates are worn, broken, painted over, missing, or unreadable, they must be replaced.

Maintain, in a secure location, an up-to-date inventory of all product and component serial numbers.

Regularly verify that identification plates have not been removed. Report any evidence of tampering to appropriate agencies and order duplicate plates.

Mark your machine with your own numbering system and take color photographs from several angles of each plate.

END OF WORK PACKAGE

**FIELD MAINTENANCE
THEORY OF OPERATION**

GENERAL

This work package explains how components of the 5-ton M939/A1/A2 series vehicles work together. A functional description of these components and their related parts will be covered in the following paragraphs.

CONTROL SYSTEM OPERATION

The control system includes those controls and their related parts essential to the operation of the vehicle. These controls are common to all vehicles with the exception of the transmission and transfer case Power Takeoff (PTO) controls. All originate from the cab. Each of these controls and related parts will be described as part of the following systems:

1. Starting and Ether Starting System Operation.
2. Accelerator Controls System Operation.
3. Parking Brake System Operation.
4. Steering System Operation.
5. Transmission Control System Operation.
6. Transfer Case Control System Operation.

STARTING AND ETHER STARTING SYSTEM OPERATION

The starting system is identical on all models covered in this manual. It will start the engine in all types of weather and has built-in protection that prevents starting components from reengaging once the engine has been started. Major components of the starting and ether starting system are:

- A. BATTERY SWITCH** - Activates all electrical circuits except arctic heaters.
- B. IGNITION SWITCH** - Has OFF, RUN, and START positions. Switch automatically returns from START to RUN when hand pressure is released.
- C. TACHOMETER** - Indicates speed of engine.
- D. VOLTMETER** - Indicates charging condition of the battery.
- E. EMERGENCY ENGINE STOP** - Control used to shut down engine during emergencies (M934/A1 series vehicles must be reset by Field Maintenance).
- F. ETHER START SWITCH** - Injects ether into engine for cold-weather starting.
- G. HAND THROTTLE CONTROL** - Used to set engine speed without applying pressure to the accelerator (rotated to lock).

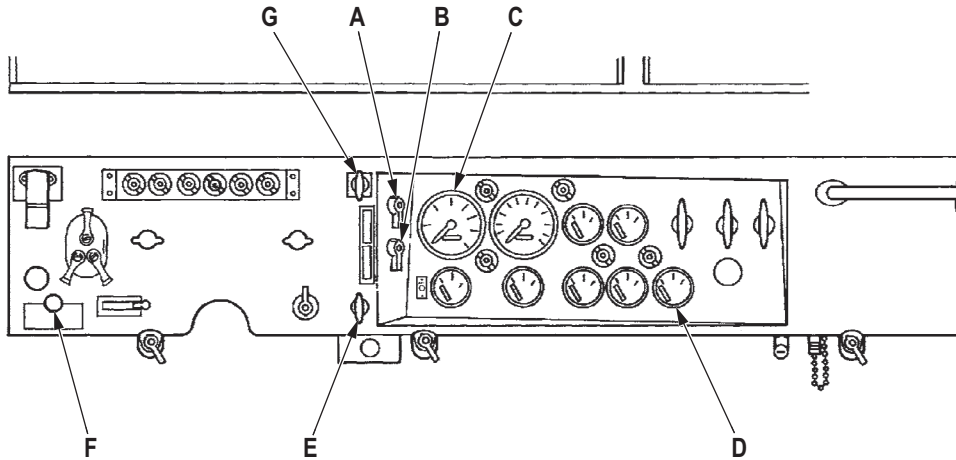

G0013DAA

Figure 1. Starting and Ether Starting Components.

STARTING AND ETHER STARTING SYSTEM OPERATION - Continued

- A. PROTECTIVE CONTROL BOX** - Prevents reengagement of starter motor once engine is running.
- B. BATTERIES** - Provide 24-volt electrical current for energizing electrical circuits.
- C. STARTER SOLENOID** - Relays 24-volt battery power to energize starter motor.
- D. STARTER MOTOR** - When energized, converts electrical energy to mechanical power as it engages flywheel to crank engine.
- E. ETHER START CYLINDER** - Stores ether used for cold-weather starting.

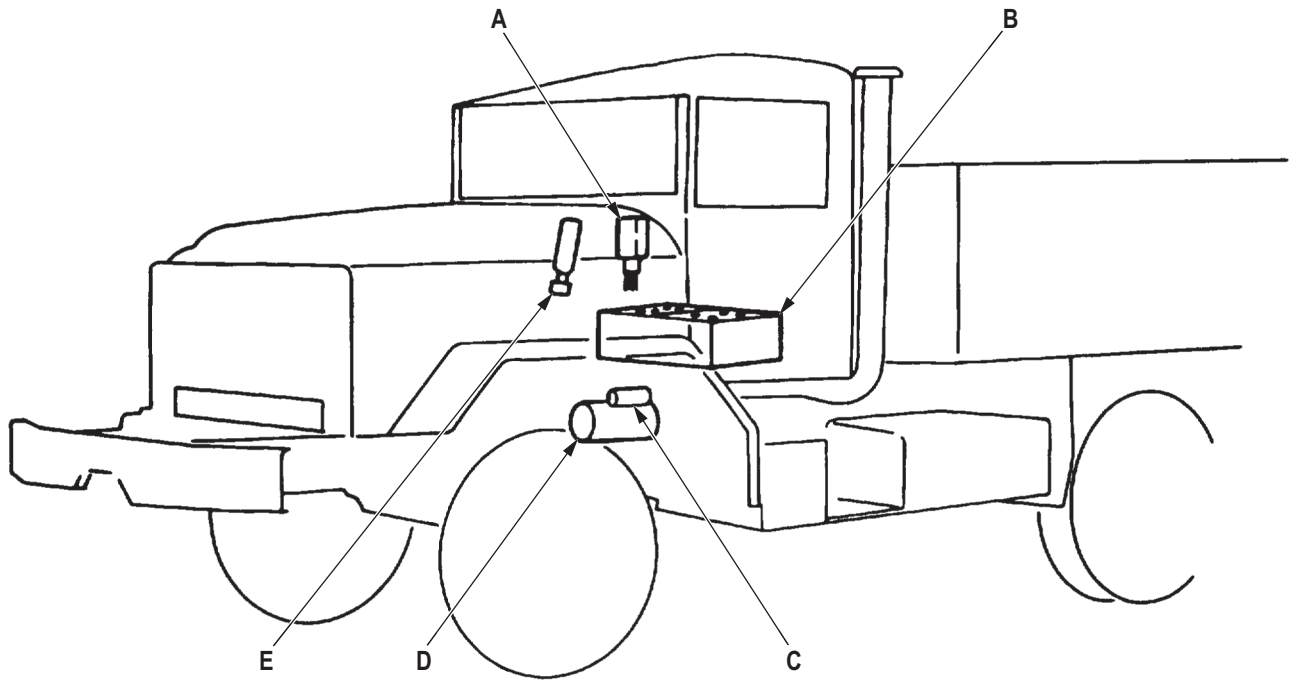

G0014DAA

Figure 2. Starting and Ether Starting Components.

ACCELERATOR CONTROLS SYSTEM OPERATION

The accelerator controls system permits the operator to control vehicle speed and engine power. It is identical on all models covered in this manual. Major components of the accelerator control system are:

- A. HAND THROTTLE CONTROL** - Used to set engine speed without maintaining pressure to the accelerator (rotated to lock).
- B. EMERGENCY ENGINE STOP CONTROL** - Is pulled out to cut off fuel to engine. Used only in an emergency.
- C. ACCELERATOR PEDAL** - Controls engine speed.
- D. MODULATOR** - With transmission selector lever in drive, modulator controls transmission upshifting and downshifting as engine rpm changes.
- E. CABLE** - Connects modulator to fuel pump.
- F. ACCELERATOR LINKAGE** - Links accelerator pedal and throttle control to fuel pump.

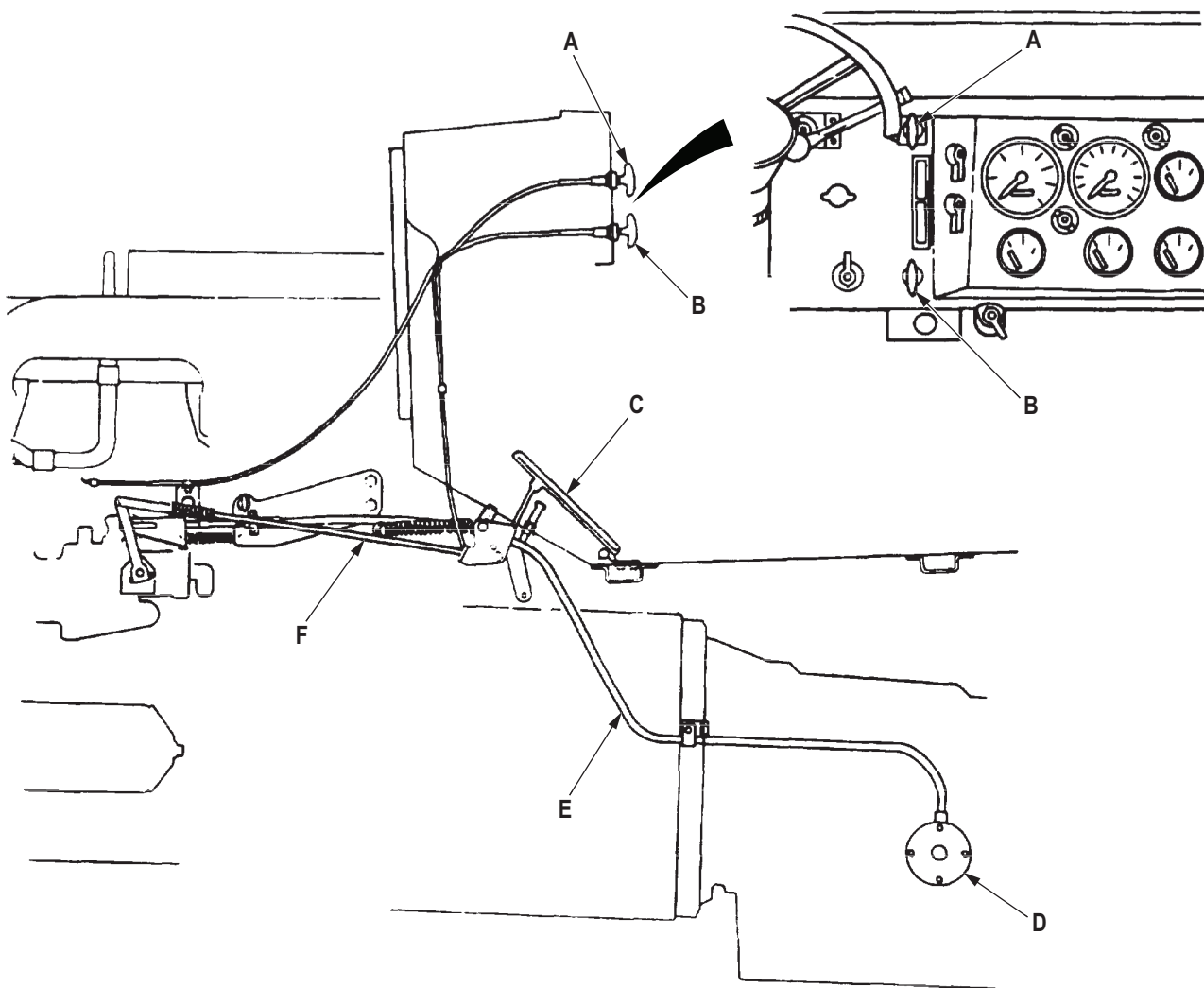

G0015DAA

Figure 3. Accelerator Controls System Components.

PARKING BRAKE SYSTEM OPERATION

A mechanical and air-actuated brake system performs the following for all vehicles covered in this manual:

1. Keeps vehicle from rolling once it has stopped.
2. Slows down or stops vehicle movement.
3. Provides emergency stopping if there is a complete air system failure.

The mechanical brake system is covered below. The compressed air function of the brake system will be covered in a following paragraph. Major components of the parking brake system are:

- A. PARKING BRAKE CONTROL LEVER** - Is positioned up to engage parking brake; down to disengage parking brake.
- B. PARKING BRAKE CONTROL LEVER ADJUSTING KNOB** - Permits operator to make minor tension adjustment of parking brake.
- C. PARKING BRAKE CABLE** - Links parking brake control lever to brake shoe lever.
- D. BRAKE SHOE LEVER** - Lever turns cam which pushes brake shoe against drum.
- E. PARKING BRAKE ADJUSTING NUT** - Permits major tension adjustment between parking brake lever and brake shoes.
- F. PARKING BRAKE WARNING LIGHT** - Illuminates when parking brake is engaged.

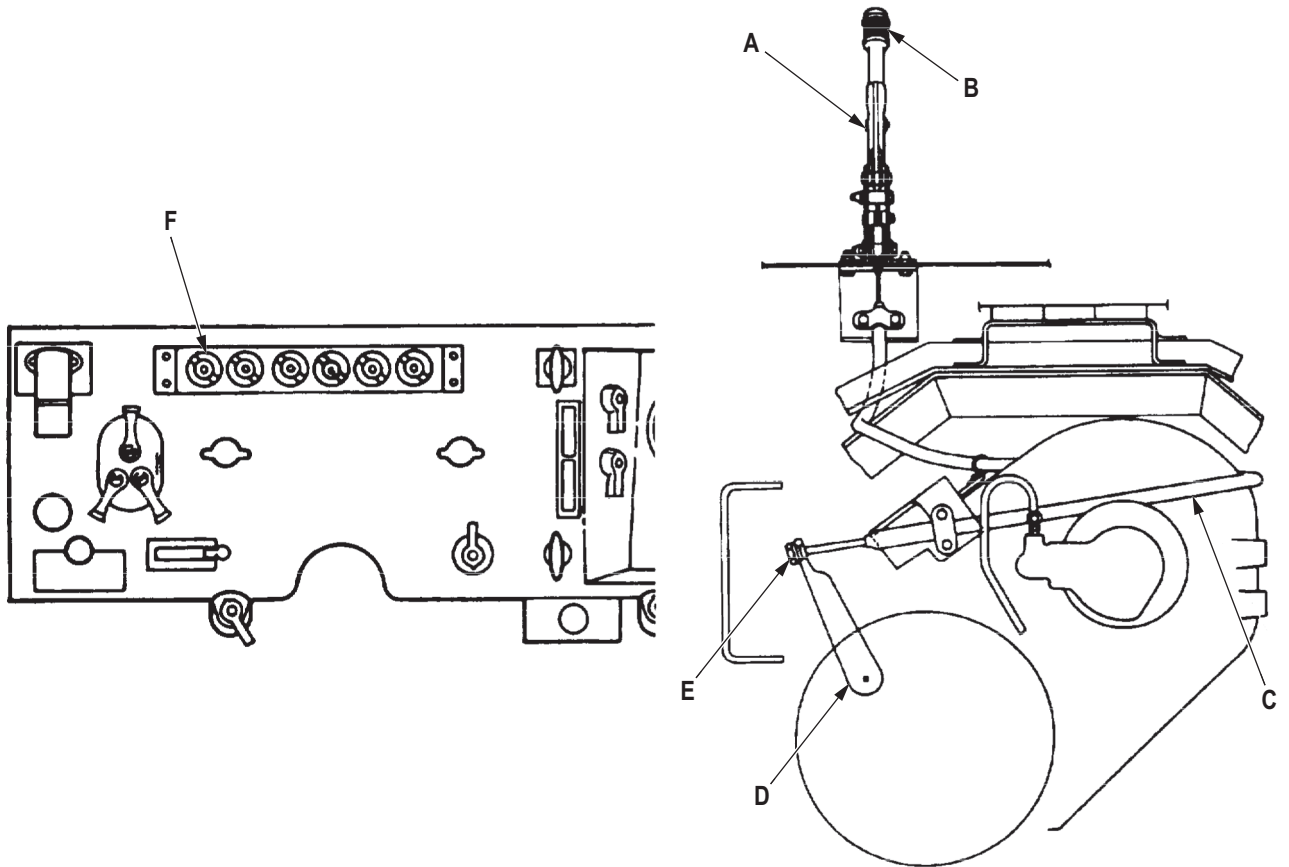
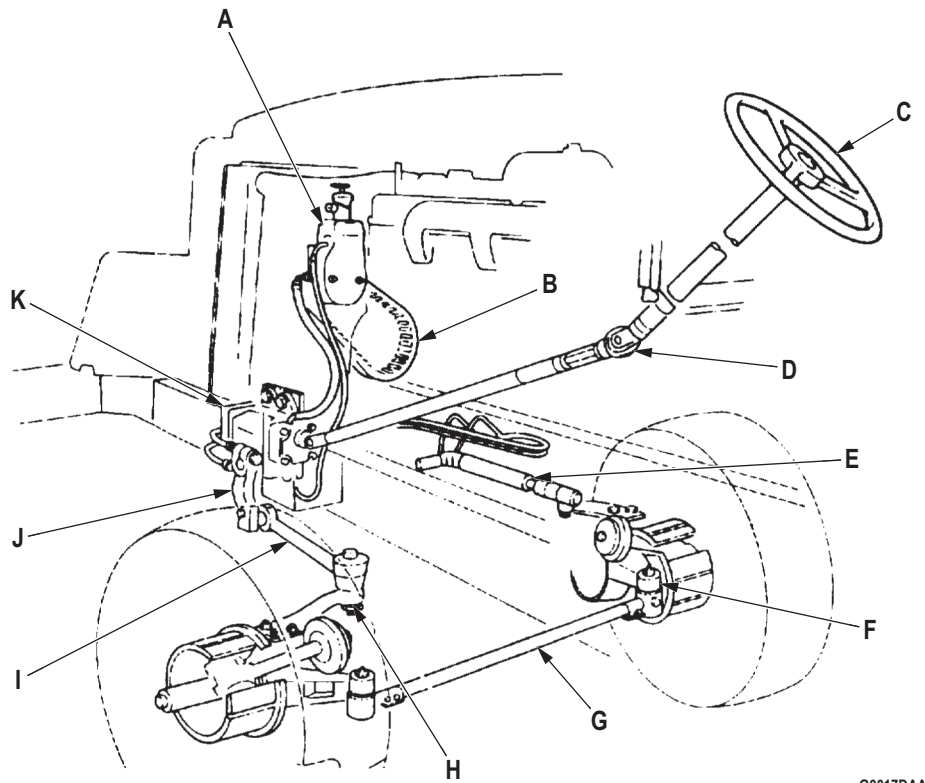

Figure 4. Parking Brake System Components.

STEERING SYSTEM OPERATION

The steering system is identical for all models covered in this manual. It is a hydraulically-assisted system that provides ease of turning and control for the operator. Major components of the steering system are:

- A. OIL RESERVOIR AND STEERING PUMP** - Combined in one unit, the reservoir serves as an oil fill point and the pump creates pressure.
- B. ACCESSORY DRIVEBELTS** - Transmit mechanical power from accessory drive pulley to steering pump pulley to drive the steering pump.
- C. STEERING WHEEL** - Serves as manual steering control for operator.
- D. STEERING COLUMN UNIVERSAL JOINT** - Connects, at an angle, the steering wheel column and input shaft of power steering gear.
- E. POWER STEERING ASSIST CYLINDER** - Receives hydraulic pressure from steering gear to assist in turning front wheels.
- F. STEERING KNUCKLE** - Serves as pivot point and link for front wheels from tie rod assembly.
- G. TIE ROD ASSEMBLY** - Connects steering knuckles so both wheels turn at the same time.
- H. STEERING ARM** - Connects drag link to steering knuckle.
- I. DRAG LINK** - Transmits movement from steering arm to pitman arm.
- J. PITMAN ARM** - Transfers torque from power steering gear to drag link.
- K. STEERING GEAR** - Converts hydraulic pressure from steering pump to mechanical power at pitman arm.



G0017DAA

Figure 5. Steering System Components.

TRANSMISSION CONTROL SYSTEM OPERATION

The transmission control system permits shifting of transmission, prevents starting of engine with transmission in gear, and prevents shifting of transfer case unless transmission is in neutral. This system also permits engagement of the transmission Power Takeoff (PTO) to provide hydraulic power for auxiliary equipment on M925/A1/A2, M928/A1/A2, M929/A1/A2, M930/A1/A2, M932/A1/A2, and M936/A1/A2 vehicles. Major components of the transmission control system are:

- A. TRANSMISSION 5TH-GEAR LOCKUP SOLENOID VALVE** - Activated by transmission control switch and transfer case switch, the 5th-gear lockup solenoid valve directs main oil pressure of transmission to the transmission governor system. This puts transmission in 5th-gear, creating less drag on transfer case synchronizer which permits smoother shifting from one transfer case drive range to another. Refer to TRANSFER CASE CONTROL SYSTEM OPERATION, for further details.
- B. TRANSMISSION NEUTRAL START SWITCH** - The neutral start switch, wired to the starter switch, prevents the engine from being started with transmission in gear.
- C. TRANSMISSION PTO** - Driven by the transmission, the PTO drives the hydraulic pump which provides hydraulic pressure to power the front winch on M925/A1/A2, M928/A1/A2, M930/A1/A2, M932/A1/A2, and M936/A1/A2 vehicles, and to power the dump body on M929/A1/A2 and M930/A1/A2 vehicles. The PTO is mounted on the right front side of the transmission.
- D. TRANSMISSION CONTROL SWITCH** - Actuates transmission lockup solenoid valve when transmission selector lever is placed in NEUTRAL and transfer case shift lever lockout switch is pressed.
- E. TRANSMISSION SELECTOR LEVER** - Is used to select vehicle driving gear range.
- F. PTO CONTROL LEVER** - Engages transmission power takeoff to provide power for auxiliary equipment.

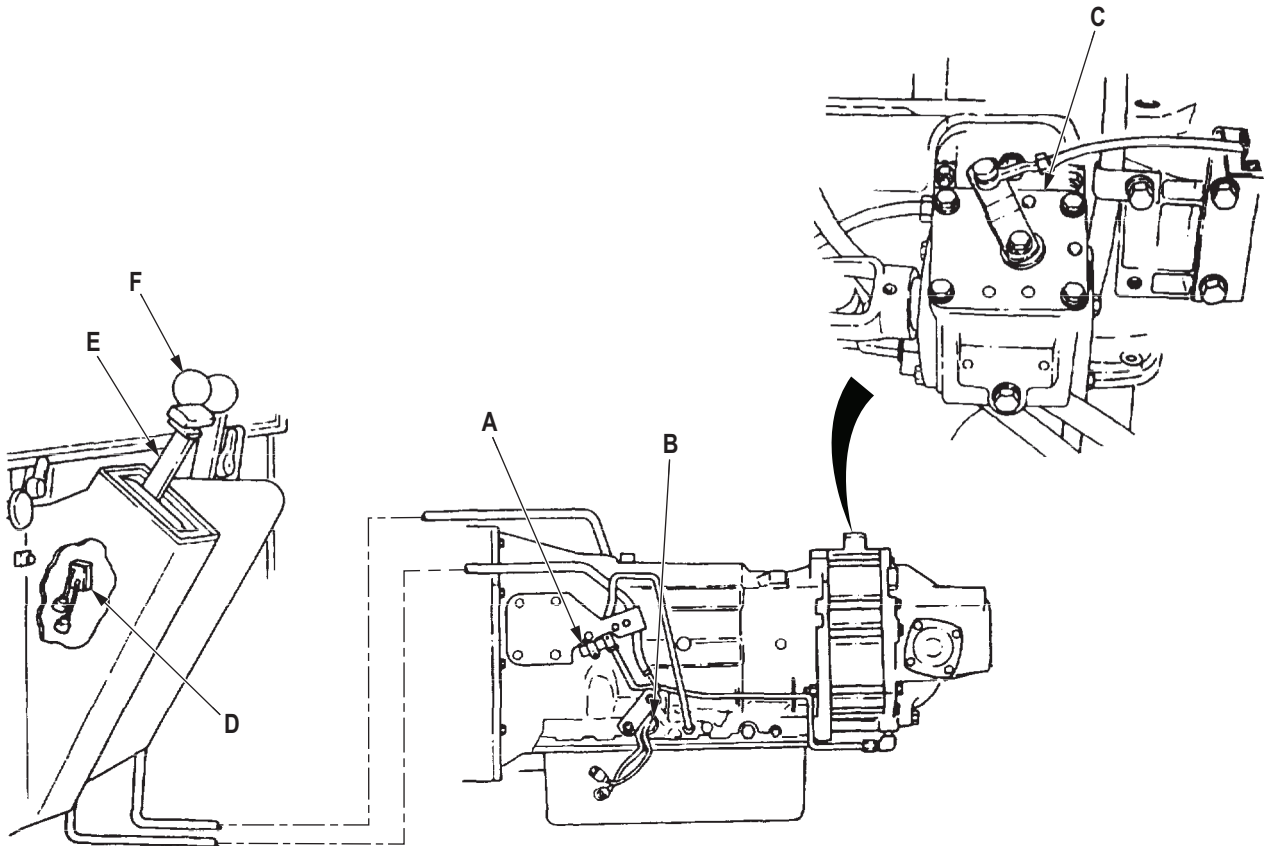

G0018DAA

Figure 6. Transmission Control System Components.

TRANSFER CASE CONTROL SYSTEM OPERATION

The transfer case control system converts four-wheel driving power into six-wheel driving power, provides smooth shifting of transfer case into high or low driving ranges while vehicle is in motion, prevents transfer case from being shifted with transmission in gear, and provides hydraulic power for auxiliary equipment through PTO.

1. Six-wheel drive is achieved two different ways, depending on the drive range (high or low) desired. In low range, the transfer case shift linkage automatically moves a cam-actuated valve which dumps air into the front drive cylinder. This forces a piston against the transfer case clutch to engage front-wheel drive. In high range, front-wheel drive is engaged in the same manner except that the front-wheel drive valve is manually actuated by the front-wheel drive lock-in switch on the instrument panel.
2. In order to shift the transfer case from one driving range to another, an interlock system working in conjunction with the 5th-gear lockup solenoid is used. This system prevents the transfer case from being shifted unless the transmission is in neutral.
3. With the automatic transmission, several actions must occur in order to shift transfer case from one driving range to another. Because of the interlock system, the transmission must be placed in neutral. The transfer case shift lever switch must also be depressed.
4. The transfer case control system, through use of a PTO driven by the transfer case, also provides hydraulic power to operate the crane and rear winch on M936/A1/A2 wreckers.
5. Major components of this system are:
 - A. TRANSFER CASE SHIFT LEVER SWITCH** - When depressed with transmission in NEUTRAL, signals interlock solenoid valve to exhaust air pressure from interlock air cylinder and actuates lockup solenoid.
 - B. TRANSFER CASE SHIFT LEVER** - Is pushed down to HIGH for light load operations, and up to LOW for heavy load operations. Six-wheel drive is achieved automatically when transfer case shift lever is placed in LOW.
 - C. TRANSFER CASE PTO CONTROL LEVER** - Manual control for engaging PTO.
 - D. TRANSFER CASE PTO** - Mounted and mechanically driven at rear of transfer case, the PTO drives a pump to supply hydraulic pressure to power the rear winch and crane on the M936/A1/A2 wreckers.
 - E. FRONT-WHEEL DRIVE LOCK-IN SWITCH** - Manual control for activating front-wheel drive valve to provide front-wheel drive with transfer case in HIGH drive range.

TRANSFER CASE CONTROL SYSTEM OPERATION - Continued

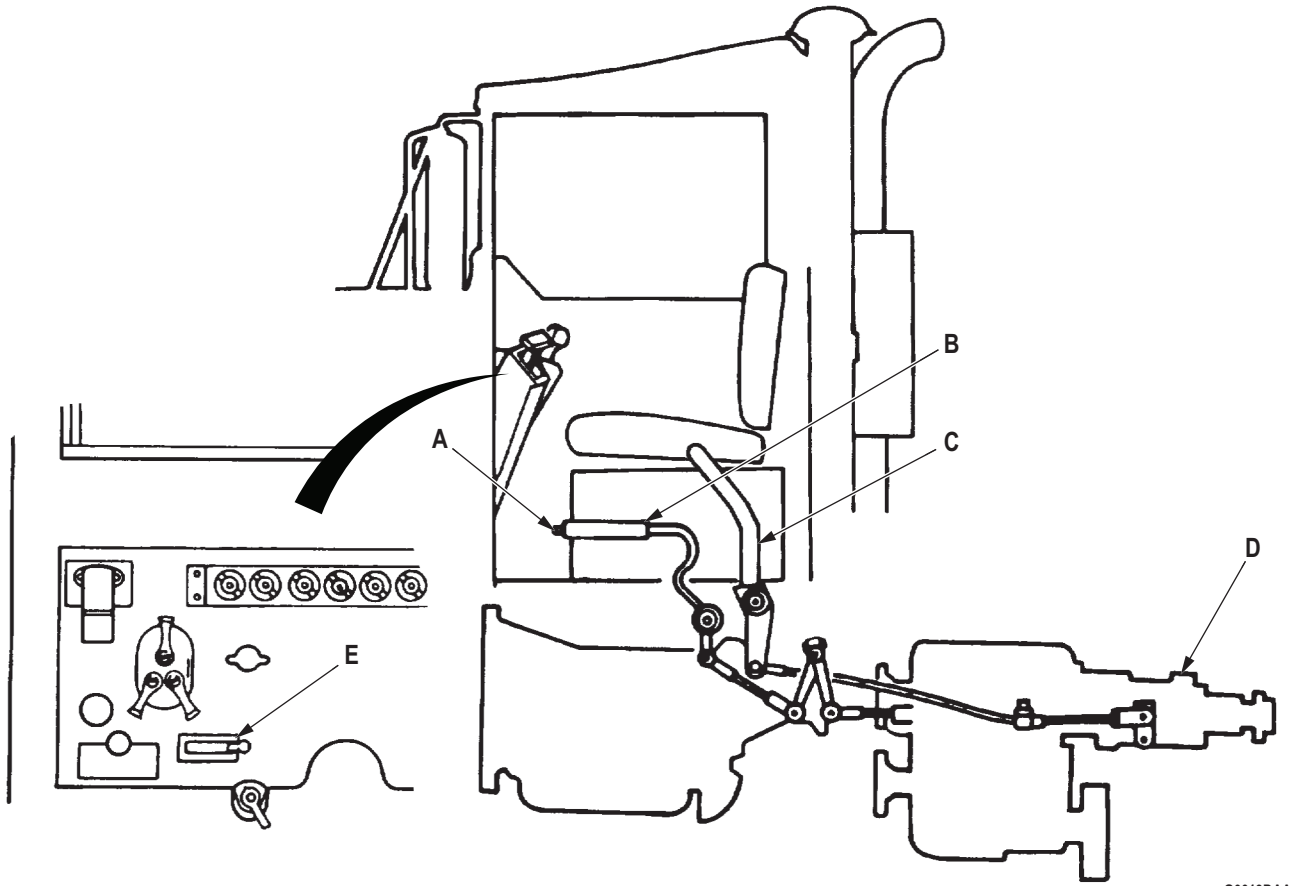

G0019DAA

Figure 7. Transfer Case Control System Components.

TRANSFER CASE CONTROL SYSTEM OPERATION - Continued

A. INTERLOCK AIR CYLINDER - Under air pressure, a piston in the interlock air cylinder forces a shaft against one of three grooves in transfer case shift lever. This prevents transfer case from being shifted with transmission in gear.

B. INTERLOCK SOLENOID VALVE - Releases air from interlock air cylinder when transmission is in NEUTRAL and transfer case shift lever switch is depressed. This permits the transfer case high/low shift shaft to move.

C. FRONT-WHEEL DRIVE AIR CYLINDER - When under pressure, it moves transfer case clutch forward to engage front-wheel drive.

D. FRONT-WHEEL DRIVE VALVE - When tripped by a cam on transfer case shift shaft, the front-wheel drive valve routes air to front-wheel drive air cylinder.

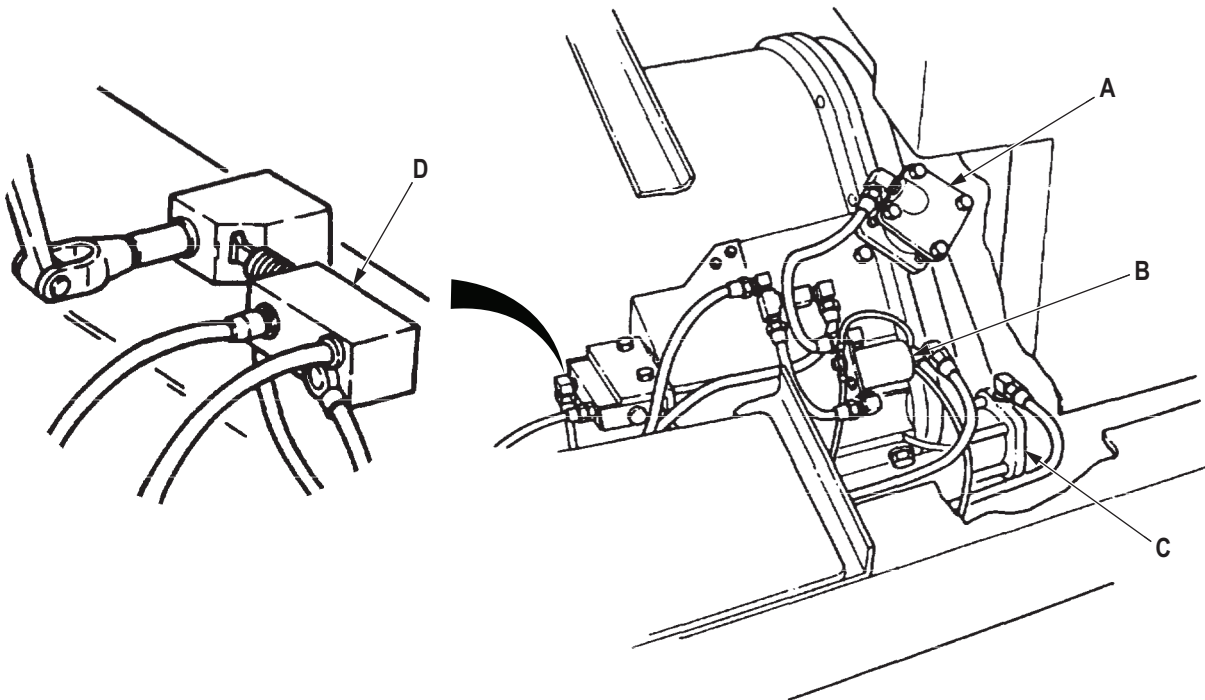

G0020DAA

Figure 8. Transfer Case Control System Components.

POWER SYSTEM OPERATION

The power system includes components that supply all vehicles covered in this manual the power to move. Each of these components will be described as part of the following subsystems:

1. Air Intake System Operation.
2. Fuel System (Dual Tank) Operation.
3. Fuel System (Single Tank) Operation.
4. Exhaust System Operation.
5. Cooling System Operation.
6. Engine Oil System Operation.
7. Powertrain System Operation.

AIR INTAKE SYSTEM OPERATION

The air intake system channels and cleans air going to the combustion chamber, where it mixes with fuel from the injectors to provide power for the engine. This system is identical on all models, except where indicated. Major components of the air intake system are:

- A. AIR CLEANER INDICATOR** - Shows red when engine air filter needs servicing.
- B. RAIN CAP** - Prevents rain and large objects from entering air intake system.
- C. AIR INTAKE EXTENSION TUBE** - Routes air to air intake system. Can be removed for shipping.
- D. STACK-TO-AIR INTAKE EXTENSION TUBE** - Routes air to air cleaner and is high enough to keep intake opening above fording level.
- E. STACK-TO-AIR CLEANER ELBOW** - Flexible connection between air stack and air cleaner.
- F. AIR CLEANER** - Filters dirt and dust from air.
- G. HOSE** - Flexible connection between air cleaner and air cleaner outlet tube.
- H. AIR CLEANER OUTLET TUBE** - Routes air from air cleaner to intake manifold.
- I. INTAKE MANIFOLD** - Distributes air to combustion chambers in each cylinder head (M939/A1 series only).
- J. TURBOCHARGER** - Mounts on exhaust manifold and uses spent exhaust gases to drive impeller and pressurize air entering aftercooler (M939A2 series only).
- K. AFTERCOOLER** - Distributes compressed air from turbocharger to combustion chambers while cooling air intake out of turbocharger (M939A2 series only).

AIR INTAKE SYSTEM OPERATION - Continued

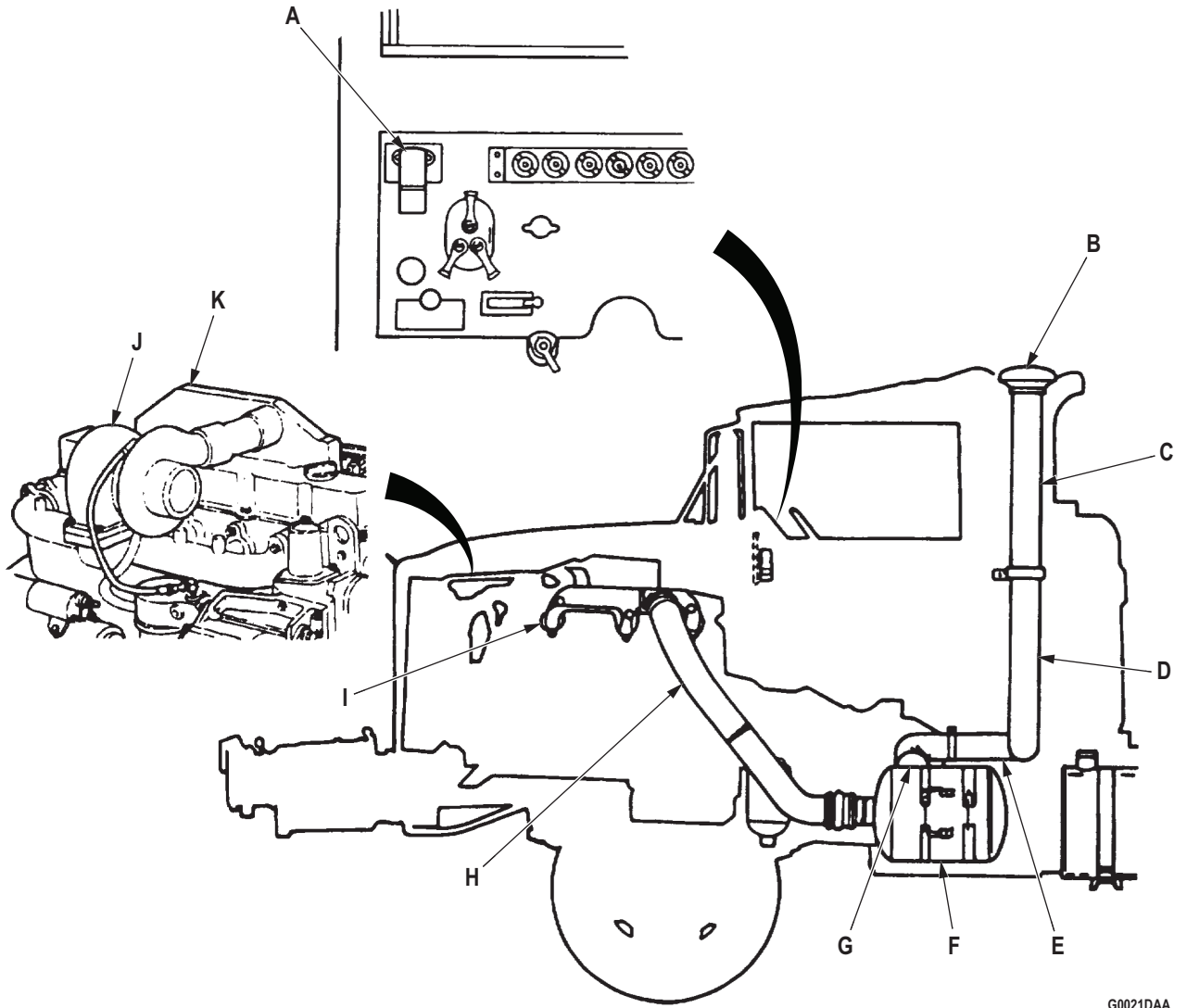

G0021DAA

Figure 9. Air Intake System Components.

FUEL SYSTEM (DUAL TANK) OPERATION

1. The fuel system stores, cleans, and supplies fuel to the fuel injectors, where it is mixed with air to initiate engine combustion.
2. The fuel system is not identical for all models. Vehicles covered in this manual have either one or two tanks. These tanks can also differ in capacity. See Table 4, Vehicle Performance Data, (WP 0002) for these differences.
3. A typical dual tank fuel system is described below. A single tank fuel system is described later. Both systems include fuel supply, return, and vent lines to provide fuel flow and release the fumes throughout the system. Major components of the dual tank fuel system are:
 - A. RIGHT TANK (REAR) VENT LINE** - Vents vapors from fuel tank to vent hole in air intake stack.
 - B. RIGHT TANK FUEL SUPPLY LINE** - Directs fuel from tank to fuel filter.
 - C. RIGHT TANK FUEL LEVEL SENDING UNIT** - Electrical signal registers fuel level in right tank at gauge on instrument panel.
 - D. LEFT TANK FUEL LEVEL SENDING UNIT** - Electrical signal registers fuel level in left tank at gauge on instrument panel.
 - E. LEFT TANK FUEL SUPPLY LINE** - Directs fuel from tank to fuel filter.
 - F. LEFT FUEL TANK** - Stores fuel for vehicle use.
 - G. LEFT TANK (REAR) VENT LINE** - Vents vapors from fuel tank to vent hole in air intake stack.
 - H. LEFT TANK FILLER CAP** - Covers fuel filler opening on left fuel tank.
 - I. LEFT TANK FUEL RETURN LINE** - Returns unused fuel back to fuel tank.
 - J. LEFT TANK (FRONT) VENT LINE** - Vents vapors from fuel tank to vent hole in air intake stack.
 - K. FUEL SELECTOR VALVE** - Manual control valve that opens fuel flow to engine from left or right fuel tank.
 - L. FUEL FILTER/WATER SEPARATOR** - Filters water and dirt from fuel.
 - M. FUEL FILTER-TO-PUMP SUPPLY LINE** - Directs fuel from fuel filter to fuel pump.
 - N. FUEL RETURN LINE** - Returns unused fuel back to fuel tanks.
 - O. FUEL PRIMER PUMP** - Purges air from fuel system.
 - P. FUEL PUMP** - Draws fuel from tank(s) and pumps it through supply line to fuel injectors.
 - Q. FUEL SUPPLY LINE** - Directs fuel from fuel pump to fuel injectors.
 - R. RIGHT TANK (FRONT) VENT LINE** - Vents vapors from fuel tank to vent hole in air intake stack.
 - S. RIGHT TANK FILLER CAP** - Covers fuel filler opening on right fuel tank.
 - T. RIGHT FUEL TANK** - Stores fuel for vehicle use.
 - U. RIGHT TANK FUEL RETURN LINE** - Returns unused fuel back to fuel tank.

FUEL SYSTEM (DUAL TANK) OPERATION - Continued

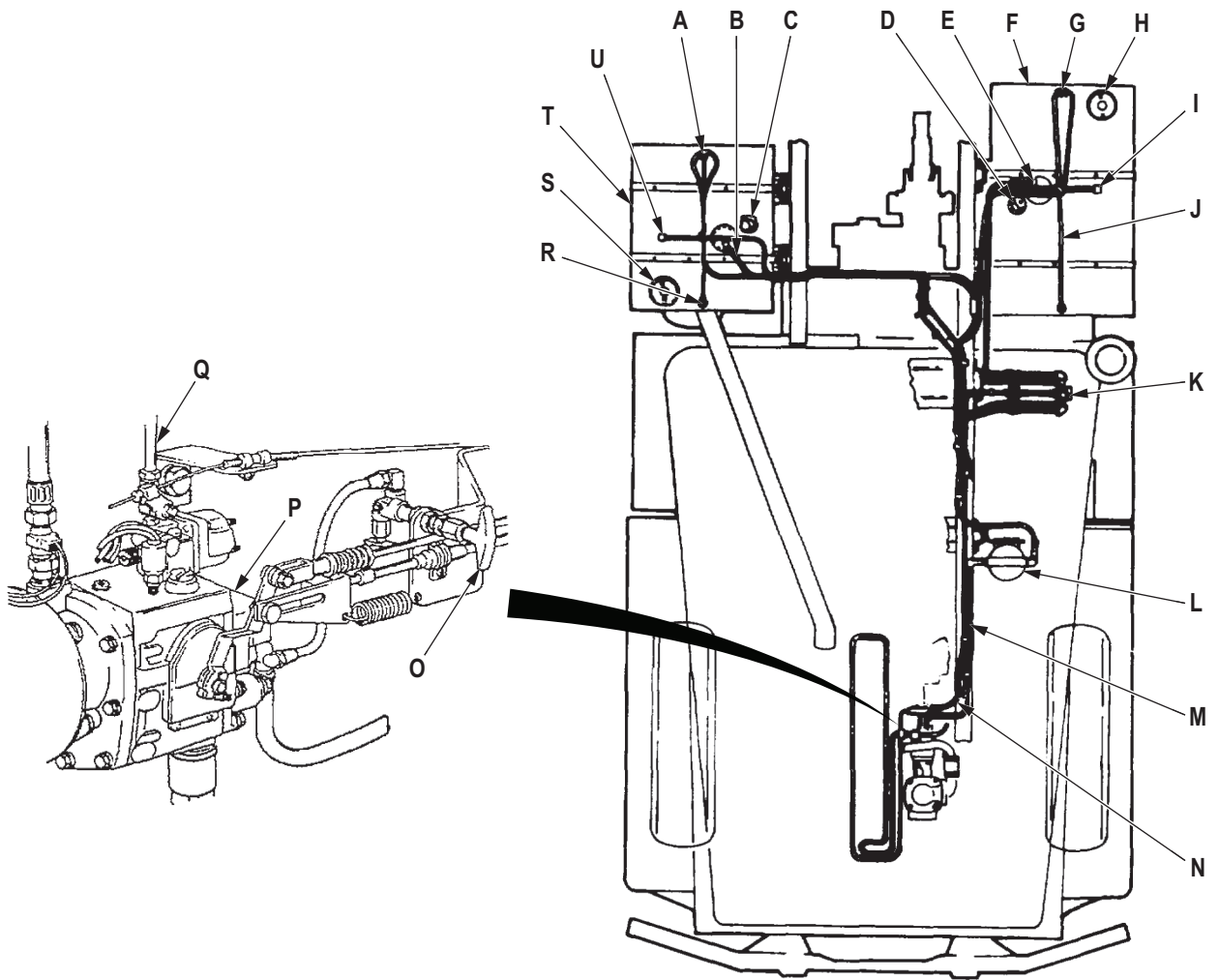

G0022DAA

Figure 10. Fuel System (Dual Tank) Components.

FUEL SYSTEM (SINGLE TANK) OPERATION

Major components of the single tank fuel system are:

- A. TANK (REAR) VENT LINE** - Vents vapors from fuel tank to vent hole-in air intake stack.
- B. TANK FILLER CAP** - Covers fuel filler opening.
- C. FUEL TANK** - Stores fuel for vehicle use.
- D. FUEL TANK LEVEL SENDING UNIT** - Electrical signal registers fuel level in tank at gauge on instrument panel.
- E. TANK (FRONT) VENT LINE** - Vents vapors from fuel tank to vent hole in air intake stack.
- F. FUEL FILTER/WATER SEPARATOR** - Filters water and dirt from fuel.
- G. FUEL RETURN LINE** - Returns unused fuel back to fuel tank.
- H. FUEL PRIMER PUMP** - Purges air from fuel system.
- I. FUEL PUMP** - Draws fuel from tank and pumps it through supply line to fuel injectors.
- J. FUEL SUPPLY LINE** - Directs fuel from fuel pump to fuel injectors.

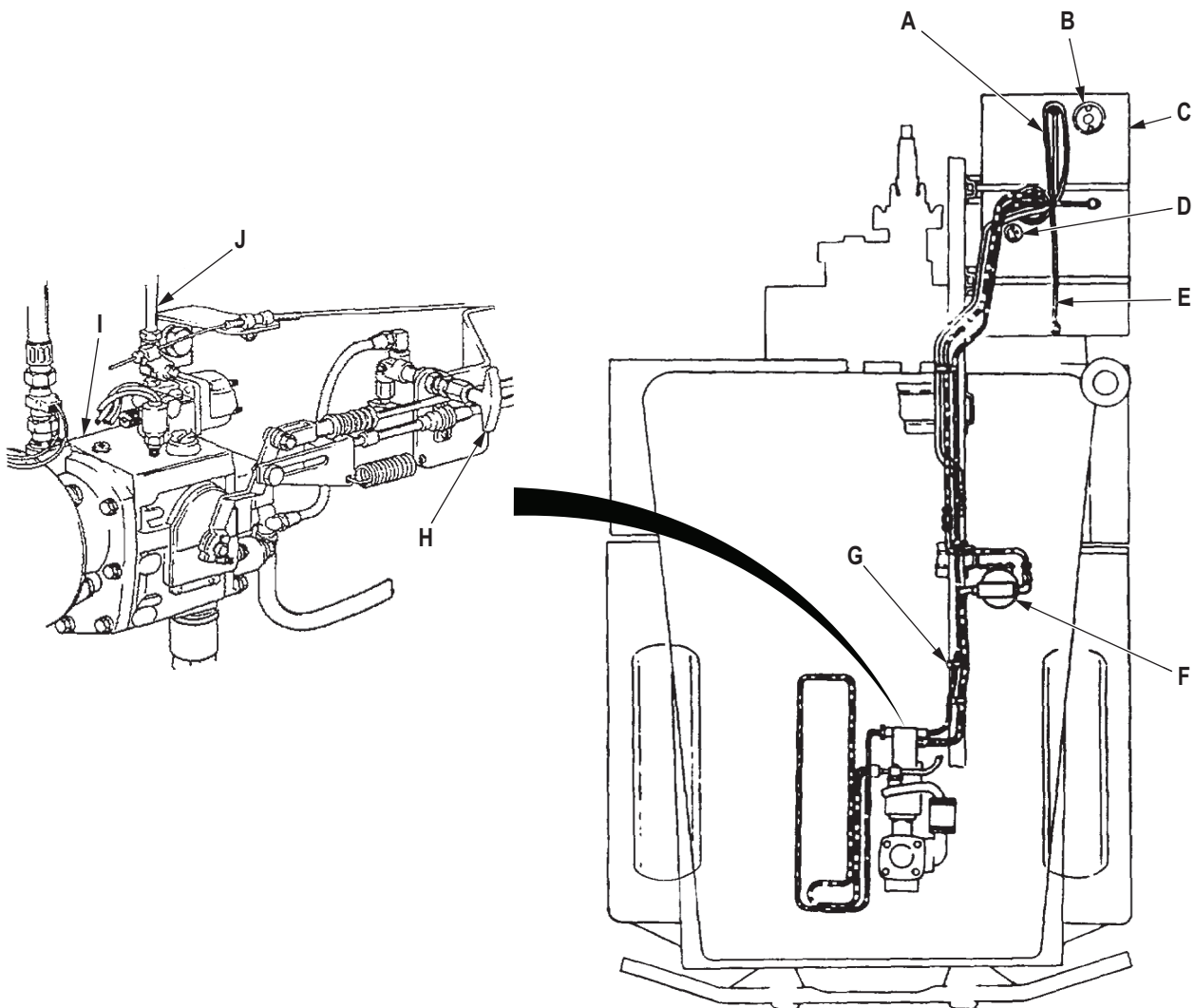

G0023DAA

Figure 11. Fuel System (Single Tank) Components.

EXHAUST SYSTEM OPERATION

The exhaust system directs exhaust gases away from the vehicle for all models covered in this manual. Major components of the exhaust system are:

- A. EXHAUST MANIFOLD** - Collects exhaust from cylinder head ports and directs it to front exhaust pipe.
- B. FRONT EXHAUST PIPE** - Directs exhaust to rear exhaust pipe.
- C. FLEX PIPE** - Part of rear exhaust pipe; allows flexibility for vibration and expansion in system.
- D. REAR EXHAUST PIPE** - Directs exhaust to muffler.
- E. MUFFLER** - Quiets exhaust noises.
- F. MUFFLER SHIELD** - Protects personnel from muffler heat.
- G. EXHAUST STACK** - Directs exhaust from muffler away from vehicle.
- H. TURBOCHARGER** - Compresses the intake air above atmospheric pressure.

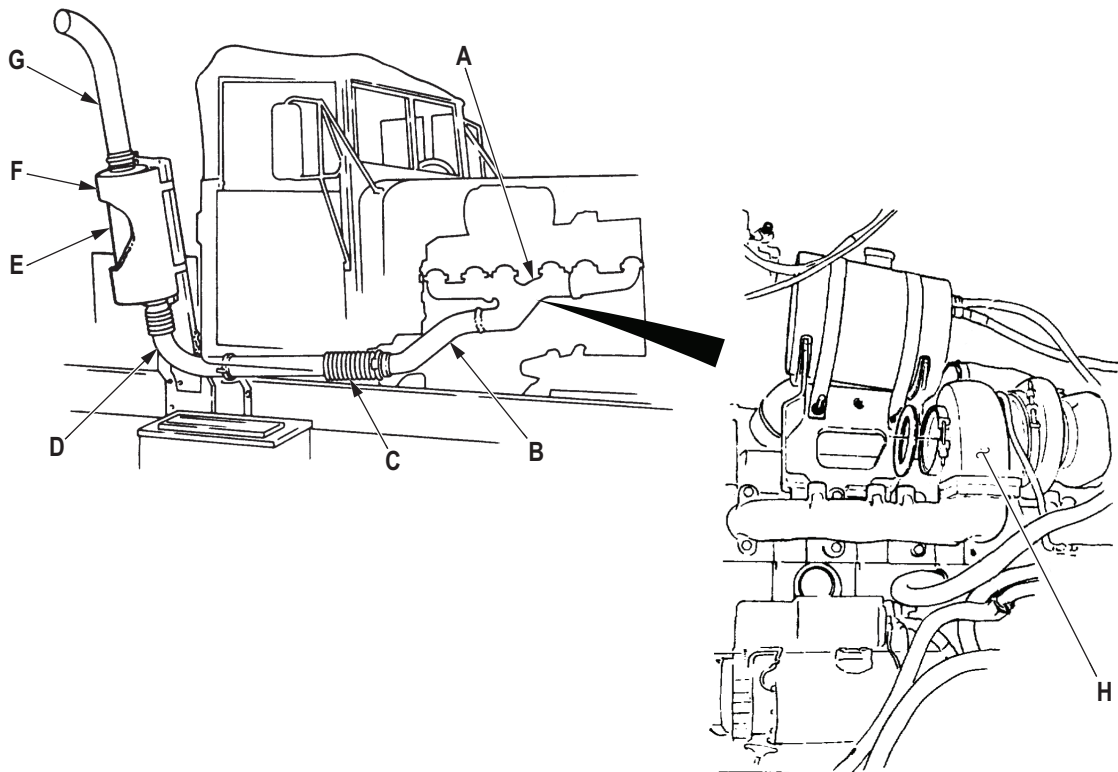

G0024DAA

Figure 12. Exhaust System Components.

COOLING SYSTEM OPERATION

This system provides cooling of the engine and transmission. It differs slightly between the M939/A1 series and M939A2 series vehicles because different engines are used. Major components of the cooling system are:

- A. WATER MANIFOLD** - Collects coolant from cylinder heads and directs it to thermostat housing (M939/A1 series only).
- B. SURGE TANK-TO-WATER MANIFOLD VENT** - Vents air trapped in water manifold (M939/A1 series only).
- C. SURGE TANK-TO-RADIATOR VENT** - Vents air in cooling system.
- D. THERMOSTAT** - Shuts off coolant flow to radiator until temperature reaches 175°F (79°C) on M939/A1 series vehicles and 181°F (83°C) on M939A2 series vehicles. Coolant is then directed to the radiator through the radiator inlet hose.
- E. RADIATOR INLET HOSE** - Directs coolant from water manifold to radiator after thermostat has opened.
- F. BYPASS TUBE** - Directs coolant back to transmission oil cooler, where it is then recirculated through the engine block until the thermostat opens.
- G. RADIATOR SHROUD** - Concentrates air flow through the radiator.
- H. RADIATOR** - Directs coolant through a series of fins or baffles so outside air can remove excessive heat from coolant.
- I. FAN CLUTCH** - Regulates use of fan to control engine temperature fan to belt-driven pulley when conditions require additional cooling.
- J. WATER PUMP** - Provides force to move coolant through engine.
- K. FAN** - Provides force to pull air through radiator.
- L. RADIATOR DRAIN VALVE** - Permits coolant to be drained from radiator.
- M. TRANSMISSION OIL COOLER HOSE** - Directs coolant to transmission oil cooler.
- N. ENGINE OIL COOLER** - Reduces heat of engine oil (M939/A1 series only).
- O. TRANSMISSION OIL COOLER** - Reduces heat of transmission oil.
- P. ENGINE OIL COOLER-TO-HEATER HOSE** - Directs coolant to personnel water heater when shutoff valve is open (M939/A1 series only).
- Q. PERSONNEL WATER HEATER** - Provides heat for cab and personnel (M939/A1 only).
- R. SURGE TANK** - Filling point for cooling system. On M939A2 vehicles, a float sensor monitors water level and illuminates a light on instrument panel.
- S. COOLANT PRESSURE CAP** - Designed to depressurize cooling system and to access cooling system for filling.

COOLING SYSTEM OPERATION - Continued

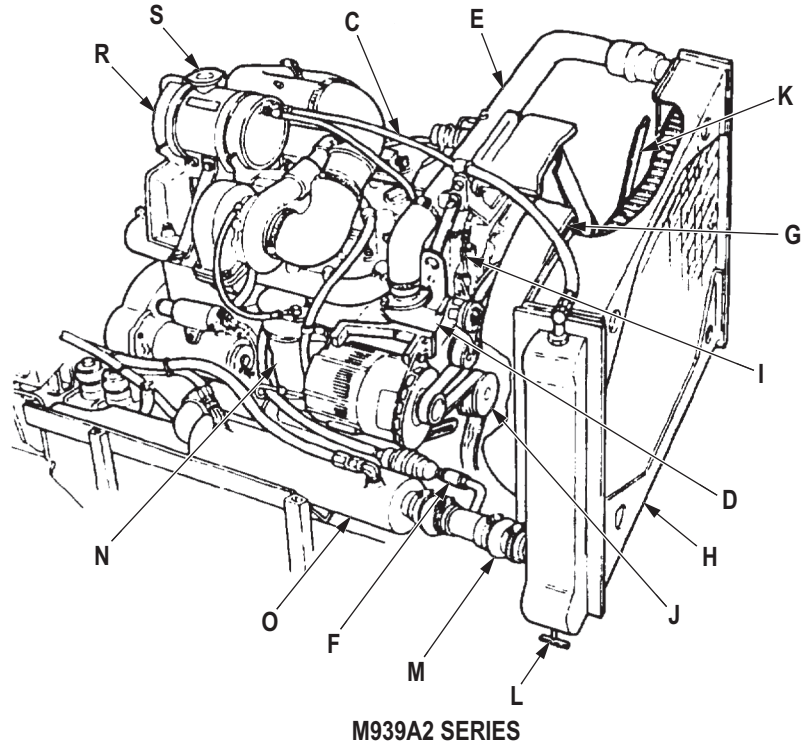
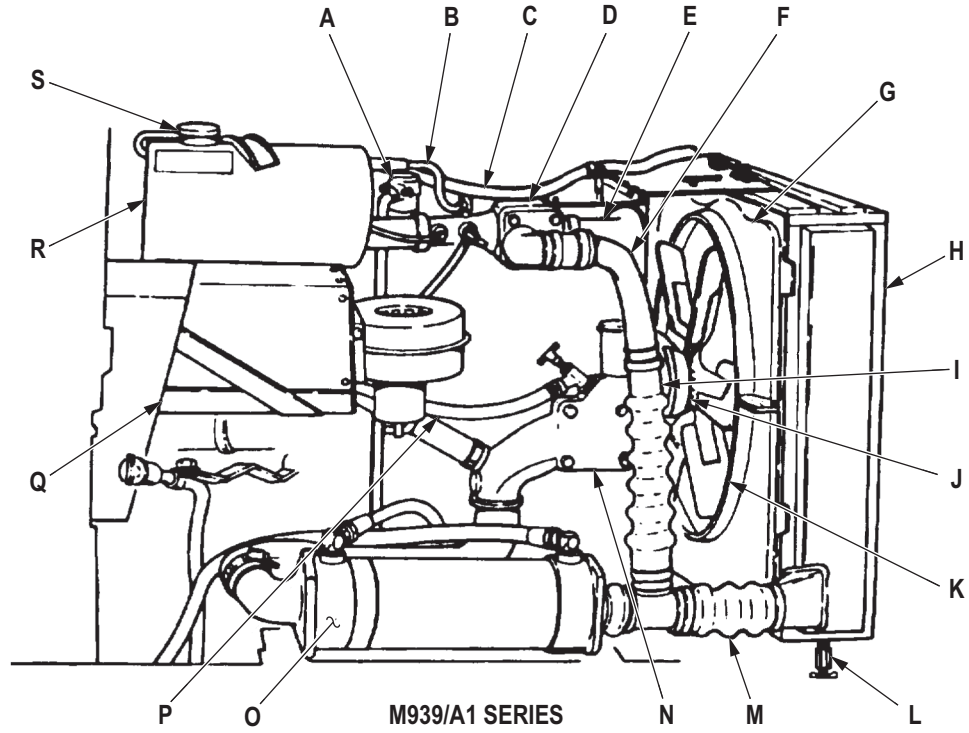

G0025DAA

Figure 13. Cooling System Components.

ENGINE OIL SYSTEM OPERATION

The engine oil system provides lubricating oil for internal moving parts. Major components of the engine oil system are:

- A. CRANKCASE BREATHER** - Vents hot engine oil fumes from engine and allows fresh air to enter.
- B. ENGINE OIL COOLER** - Removes heat from engine oil as coolant circulates through internal tubes of oil cooler.
- C. OIL DIPSTICK** - Indicates engine oil level.
- D. OIL FILTER** - Filters out foreign particles suspended in oil.
- E. OIL FILLER CAP** - Located on rocker lever cover, cap covers engine oil fill opening.
- F. OIL PRESSURE TRANSMITTER** - Sends an electrical signal that indicates engine oil pressure to gauge on instrument panel.
- G. OIL PAN DRAIN PLUG** - Plugs engine oil drain opening.
- H. OIL PAN** - Reservoir for engine oil.
- I. OIL SUPPLY LINE** - Carries oil from oil pan to oil pump.
- J. OIL BYPASS RETURN LINE** - Returns oil from oil pump to oil pan.
- K. OIL PUMP** - Provides mechanical pressurization of oil to circulate it through oil system.

ENGINE OIL SYSTEM OPERATION - Continued

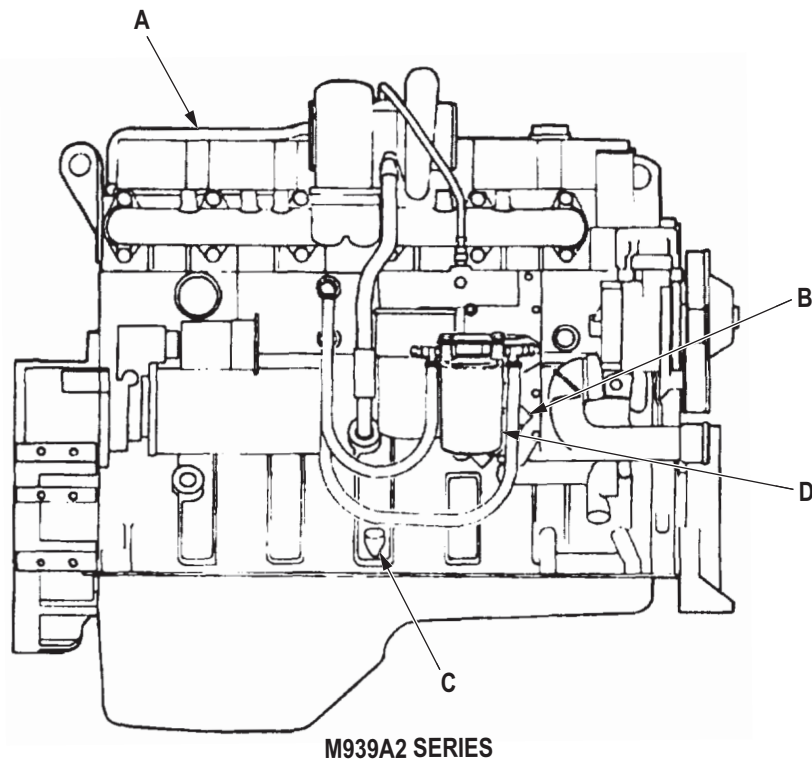
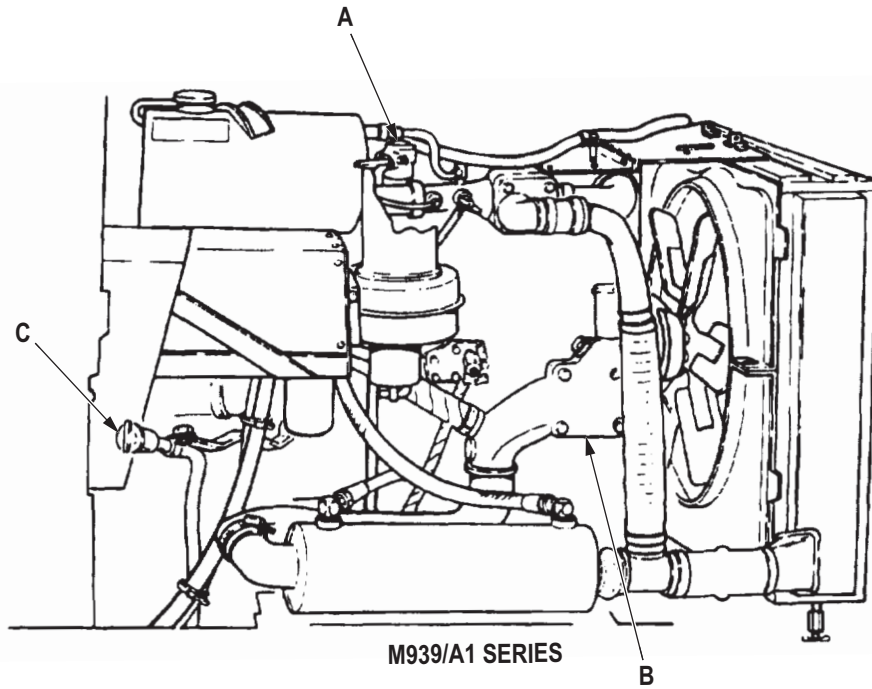

G0026DAA

Figure 14. Engine Oil System Components.

ENGINE OIL SYSTEM OPERATION - Continued

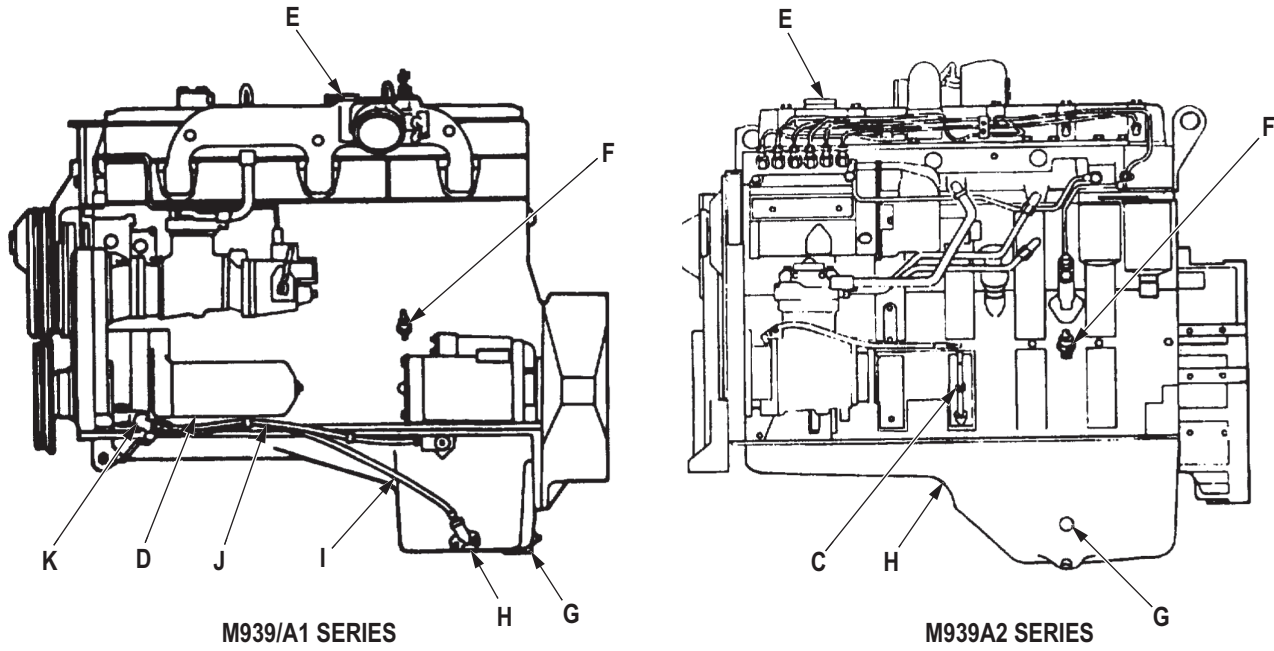

G0027DAA

Figure 15. Engine Oil System Components.

POWERTRAIN SYSTEM OPERATION

The powertrain system is the same on all models in this manual except the extra-long wheelbase models, which have an additional propeller shaft and center bearing. This system transmits engine power to the axles to put the vehicle in motion. Major components of the powertrain system are:

- A. UNIVERSAL JOINTS** - Connections between two propeller shafts that permit one to drive the other even though they may be at different angles.
- B. DIFFERENTIALS** - Distribute power to left and right axle shafts.
- C. AXLES** - Transmit power from differentials to rotate wheels.
- D. PROPELLER SHAFTS** - Serve as driving shafts that connect transmission to transfer case and transfer case to differentials.
- E. ENGINE** - Provides power needed for powertrain component operation.
- F. TRANSMISSION** - Adapts engine power to meet different driving conditions.
- G. CENTER BEARING** - Provides support for propeller shaft to decrease vibration and wear on universal joints (M927/A1/A2, M928/A1/A2, and M934/A1/A2 series only).
- H. TRANSFER CASE** - Distributes power evenly to front and rear axles.

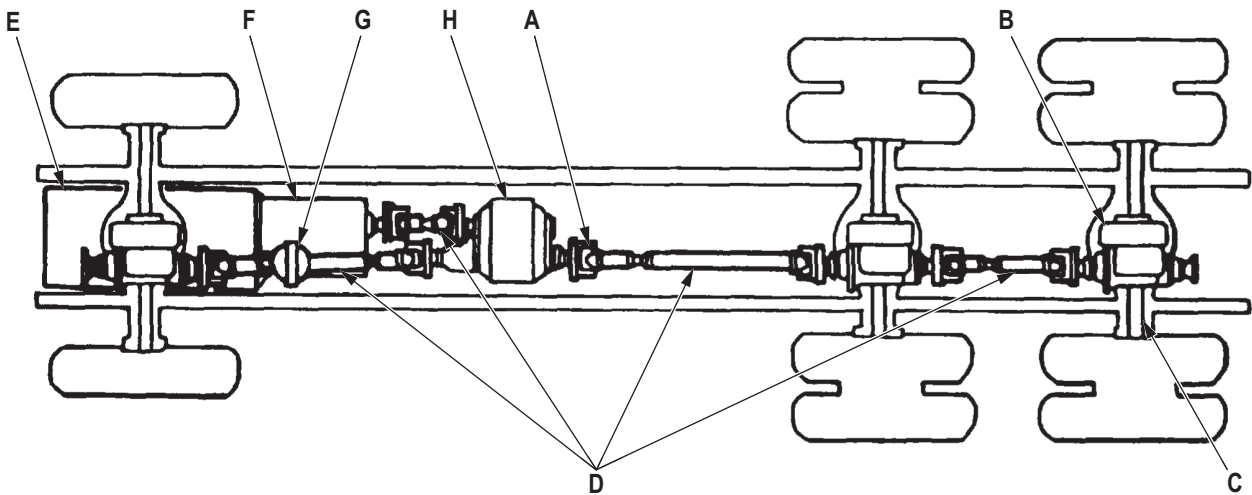

G0028DAA

Figure 16. Powertrain System Components.

ELECTRICAL SYSTEM OPERATION

Nearly every component of models covered in this manual is affected by the electrical system. These components and their electrical connections are described as part of the following electrical subsystems:

1. Battery System Operation.
2. Starting System Operation.
3. Ether Starting System Operation.
4. Generating System Operation.
5. Directional Signal System Operation.
6. Heating System Operation.
7. Indicator, Gauge, and Warning System Operation.
8. Trailer and Semitrailer Connection System Operation.

ELECTRICAL TERMS AND DEFINITIONS

The following electrical terms and definitions will be frequently referred to throughout this section and should be understood before proceeding:

Alternating Current (AC signal) - Current in a circuit that flows in one direction first, then in the other direction.

Circuit - A complete path for electric current flow between components.

Circuit Breaker - An automatic switch that interrupts current flow in a circuit when the current limit is exceeded.

Direct Current (DC signal) - Current in a circuit that flows in one direction.

Female Connector - One-half of a connector which fits over the other half.

Ground - A common return to complete a path for current flow in a circuit.

Harness - A group of wires connected between devices that are bundled and routed together to prevent damage and make repair and replacement easier.

Male Connector - One-half of a connector which fits the other half.

Polarity - The direction current flows in a circuit (usually positive to negative).

Relay - An electromagnetic device that operates like an automatic switch to control flow of current in the same or different circuit.

Reverse Polarity - The condition that exists when circuit polarity is connected opposite of that which was intended.

Sending Unit - A device that produces an electrical signal and sends this signal to the device which will make use of it.

Sensor - An electrical sensor takes a physical condition (temperature, oil presence or absence) and converts it into an electrical signal.

Splice - A permanent physical connection of two or more wires.

Terminal - Fastener at end of wire used to connect the wire to an electrically-powered device.

BATTERY SYSTEM OPERATION

The battery system is identical for all models covered in this manual and consists of the following major components and circuits:

A. BATTERIES - Four 6TN batteries are connected in series parallel to provide 24-volts DC for electrical starter system and 12-volts DC for the heater fan low speed.

B. SLAVE RECEPTACLE - Links an external power source directly to the slaved vehicle's batteries to assist in cranking engine when batteries are not sufficiently charged.

C. CIRCUIT 7 - Provides a ground between starter, battery, and chassis.

D. PROTECTIVE CONTROL BOX - Protects the vehicle electrical system in the event battery system polarity is reversed. Connects battery power to vehicle electrical lead through circuit 81 and circuit 5. Connects positive ground through circuit 94 to the starter.

E. BATTERY SWITCH - Controls a relay in protective control box through circuit 459 that connects batteries to vehicle electrical load.

F. STARTER SOLENOID - Junction point for battery positive lead (circuit 6) and vehicle electrical feed wire (circuit 81).

G. CIRCUIT 6 - Connects batteries to starting motor and to protective control box through circuit 81.

BATTERY SYSTEM OPERATION - Continued

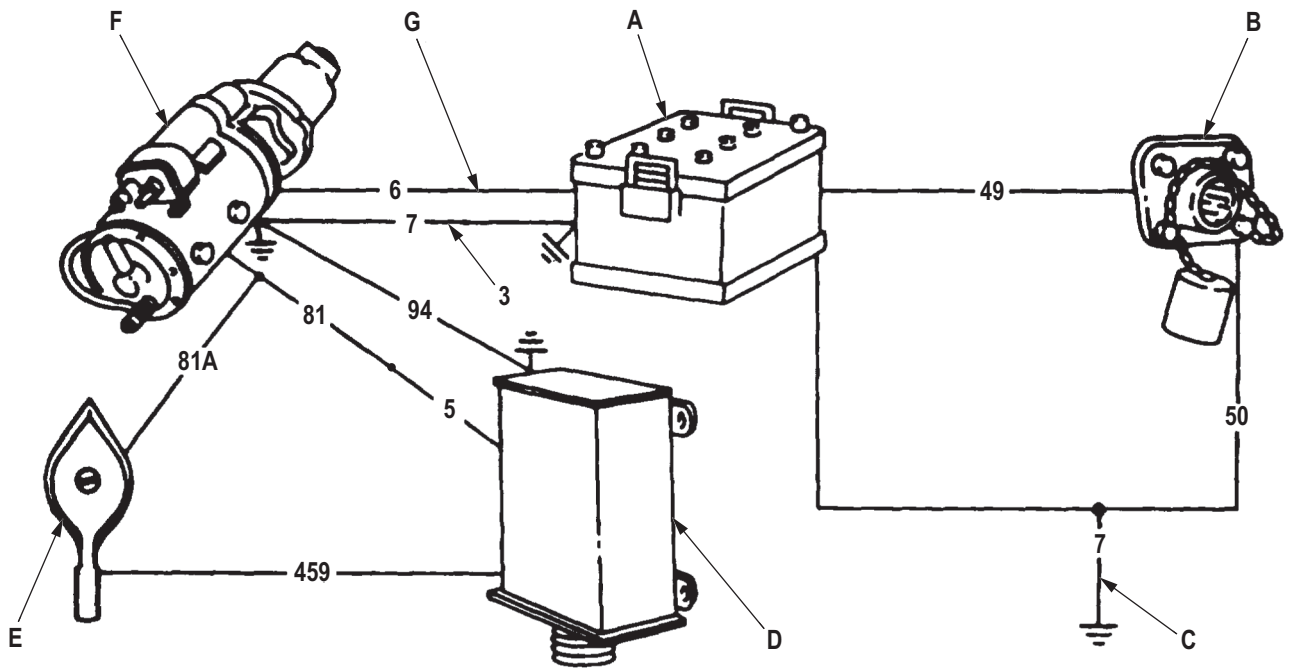

G0029DAA

Figure 17. Battery System Components.

STARTING SYSTEM OPERATION

The starting system is identical for all models covered in this manual and consists of the following major components and circuitry:

- A. PROTECTIVE CONTROL BOX** - Locks out starter circuit, which prevents starter from reengaging while engine is running.
- B. IGNITION SWITCH** - Provides battery power to fuel solenoid through circuits 54 and the neutral start safety switch through circuit 498.
- C. NEUTRAL START SAFETY SWITCH** - Prevents starter from energizing when vehicle is not in neutral, by deenergizing circuit 499 and a relay in the protective control box, which disconnects power from circuit 74 and the starter solenoid.
- D. STARTER SOLENOID** - A magnetic relay that is powered by circuit 74 to transmit 24-volt battery power to the starter motor through circuit 6.
- E. STARTER MOTOR** - Cranks engine for starting. Supplied with 24-volt battery power through circuit 6.
- F. BATTERY SWITCH** - Completes circuit 459, closing a relay in the protective control box to supply power to ignition switch through circuits 5 and 5B.

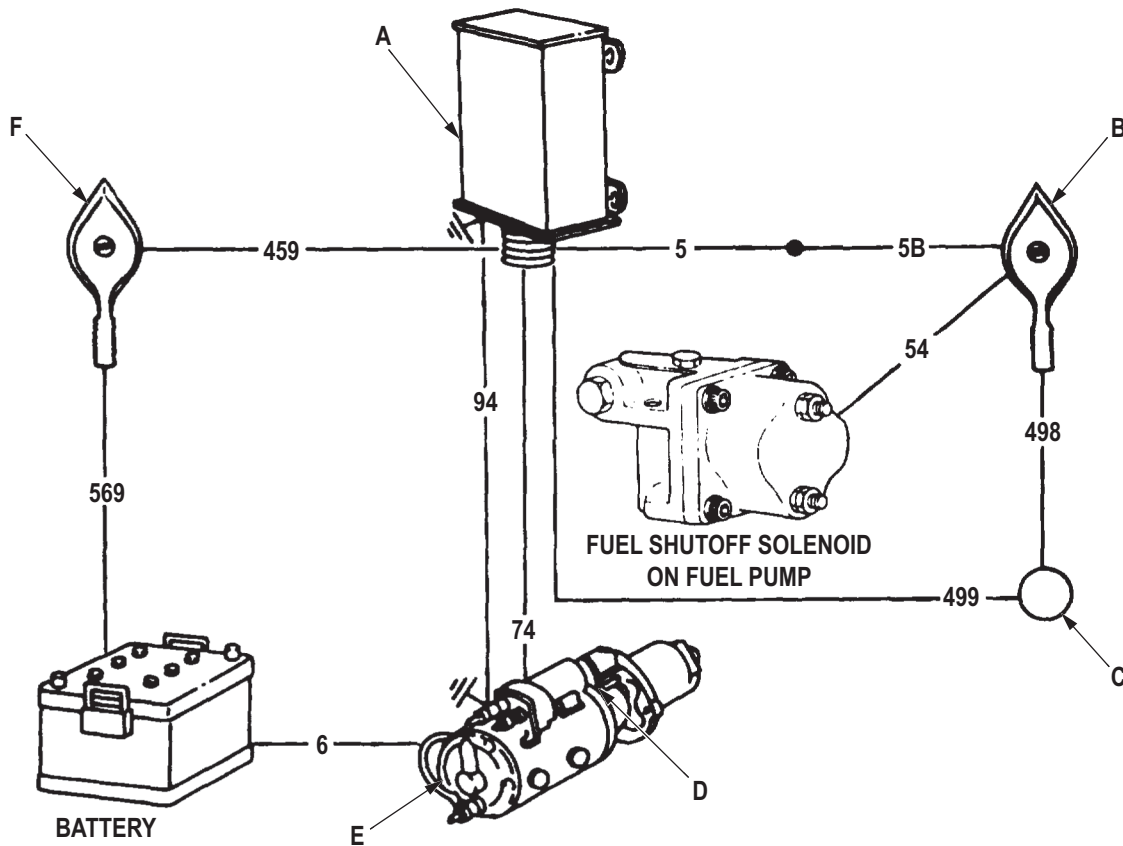

G0030DAA

Figure 18. Starting System Components.

ETHER STARTING SYSTEM OPERATION

The ether starting system is identical for all models covered in this manual and consists of the following major components and circuitry:

- A. BATTERY SWITCH** - Provides 24-volt battery to protective control box through circuits 459, 81A, and 81.
- B. PROTECTIVE CONTROL BOX** - Energizes ether feed switch through circuits 5, 5A, 27, 5C, and 570.
- C. ETHER FEED SWITCH** - Controls 24-volt power to ether pressure switch through circuit 570.
- D. ETHER PRESSURE SWITCH** - Connects ether feed switch to ether tank valve through circuit 570.
- E. ETHER TANK VALVE** - Is activated through circuit 570 when ether pressure switch is closed and ether feed switch is pressed.

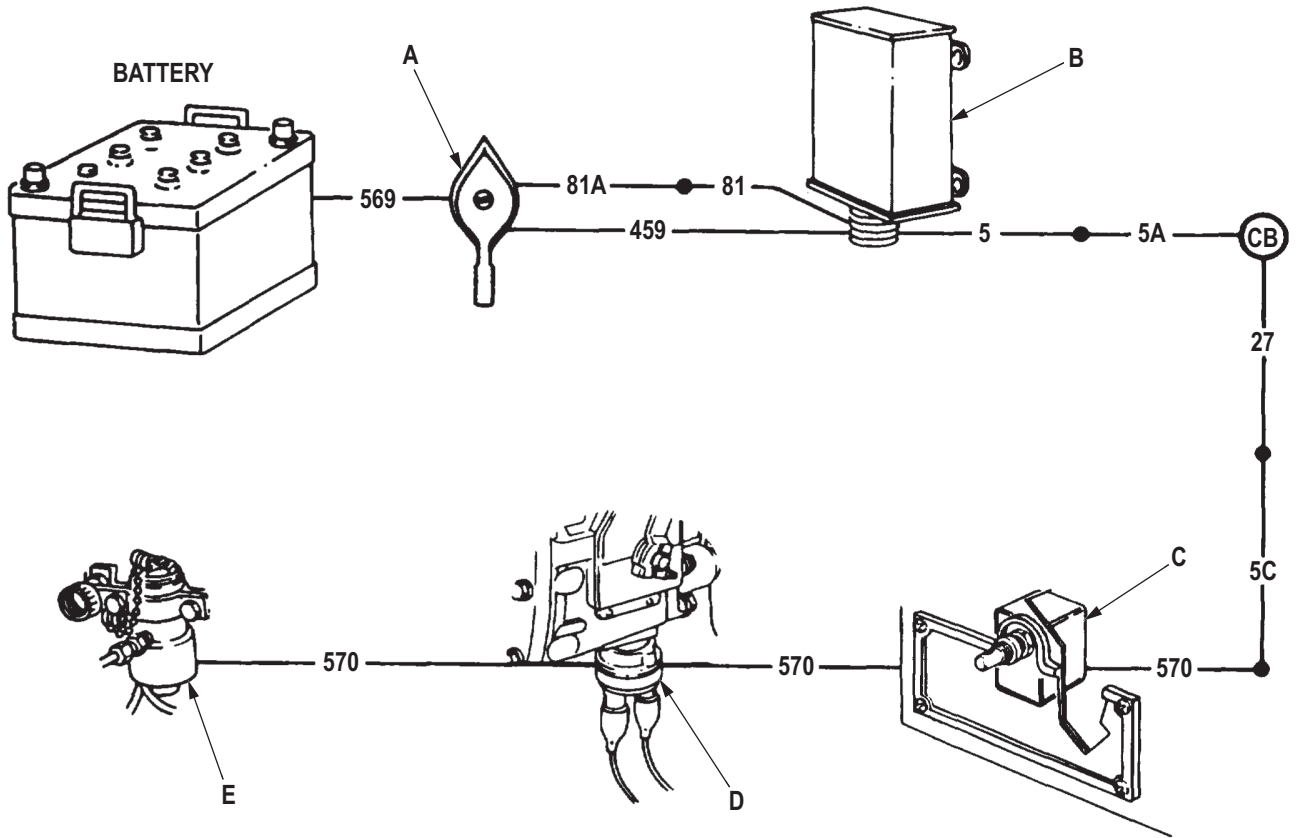

G0031DAA

Figure 19. Ether Starting System Components.

GENERATING SYSTEM OPERATION

The generating system is identical for all vehicles covered in this manual and consists of the following major components and circuitry:

- A. VOLTMETER** - Indicates electrical system voltage. It is connected to the electrical system through circuit 27.
- B. ALTERNATOR** - Rated at 26-30 volts, 60 amperes, the alternator assists and recharges batteries during operation. A 100-ampere model is available as a kit.
- C. CIRCUIT 3** - Provides a ground circuit to alternator.
- D. CIRCUIT 566** - Controls a relay in protective control box that prevents starter from reactivating while engine is running.
- E. CIRCUIT 568** - Senses system voltage and excites the alternator field.
- F. PROTECTIVE CONTROL BOX** - Connects circuit 5 to 80 to power the electrical system and charge the batteries.
- G. CIRCUIT 5** - Conducts alternator output to charge batteries and maintain vehicle voltage.
- H. BATTERY SWITCH** - Closes relay in protective control box that connects battery circuits.

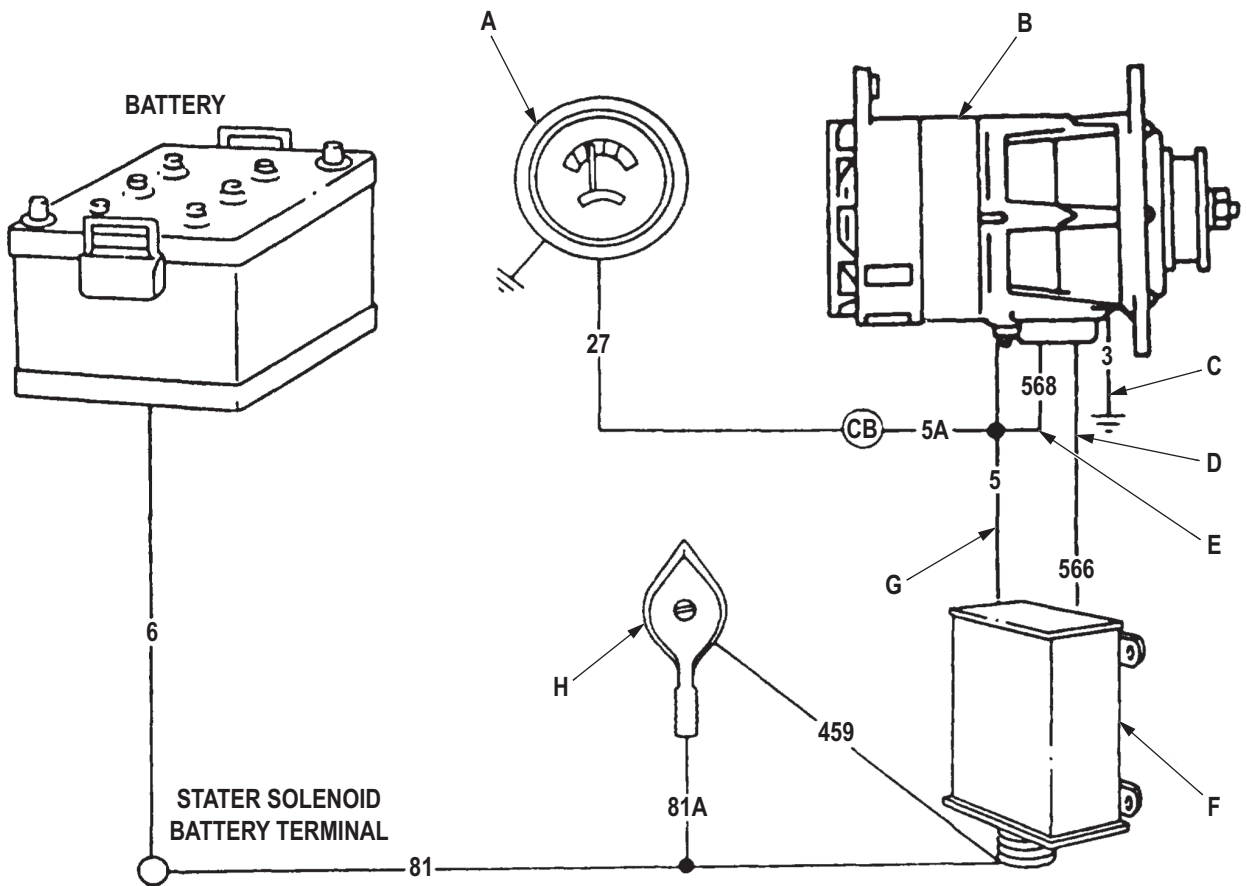

G0032DAA

Figure 20. Generating System Components.

DIRECTIONAL SIGNAL SYSTEM OPERATION

The directional signal system is identical on all models covered in this manual and consists of the following major components and circuitry:

- A. LIGHT SWITCH** - Provides battery power to directional signal switch through circuits 460 and 461 and to stoplight switch through circuit 75.
- B. STOPLIGHT SWITCH** - Closing this switch allows power to flow from light switch through circuit 75 to circuit 22 to directional signal switch.
- C. REAR COMPOSITE LAMPS** - Receive power from turn signal control through circuit 22-460 and 22-461 to indicate turning direction.
- D. TURN SIGNAL FLASHER** - Receives power through circuit 467A and sends intermittent current to the signal lamp through circuit 467B.
- E. DIRECTIONAL SIGNAL SWITCH** - A four-position switch that directs power to composite and signal lamps through circuits 460, 461, 22-460, and 22-461 to indicate direction of turn.
- F. FRONT COMPOSITE LAMP** - Receives power from turn signal control through circuits 460 and 461 to indicate turning direction.

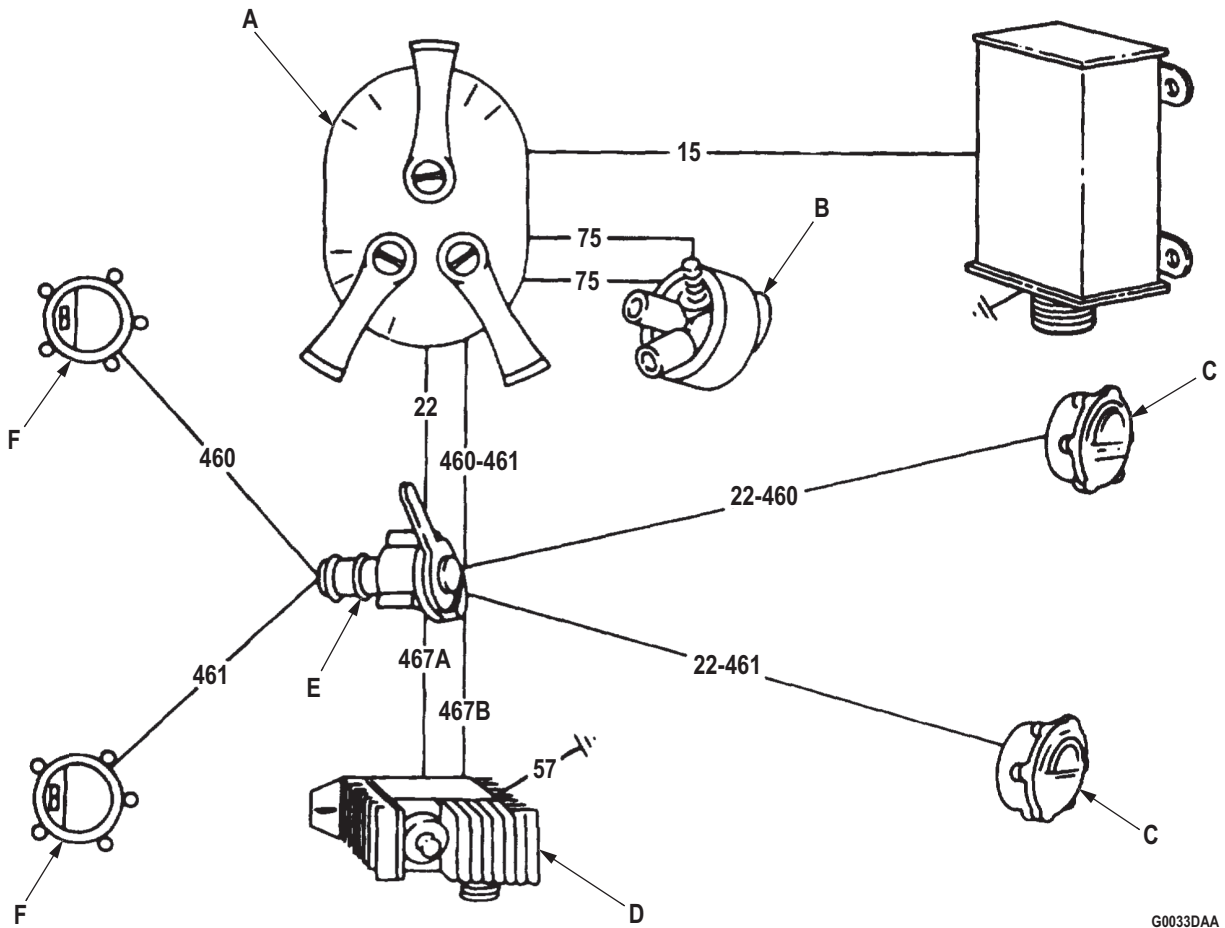

G0033DAA

Figure 21. Directional Signal System Components.

HEATING SYSTEM OPERATION

The electrical portion of the heating system is identical for all models covered in this manual and consists of the following major components and circuitry:

- A. PROTECTIVE CONTROL BOX** - Provides 24-volt power to circuit breaker through circuits 5 and 5A and to heater switch through circuits 27 and 5C.
- B. CIRCUIT BREAKER** - Provides overload protection for 24-volt circuits 5, 5A, 27, and 5C leading to the heater switch.
- C. BATTERY SWITCH** - Provides 12-volt battery power from circuit 569 through 569A to the heater.
- D. CIRCUIT BREAKER** - Provides overload protection for 12-volt circuit 569A leading to heater switch.
- E. HEATER SWITCH** - Controls low and high blower motor speed and has two sources of power: 12-volt power is supplied through circuit 569A from battery switch and is used to provide low speed; 24-volt power is supplied through circuit 5C from protective control box and is used to provide high speed.
- F. HEATER BLOWER MOTOR** - A direct current motor controlled by heater switch through circuit 400.

HEATING SYSTEM OPERATION - Continued

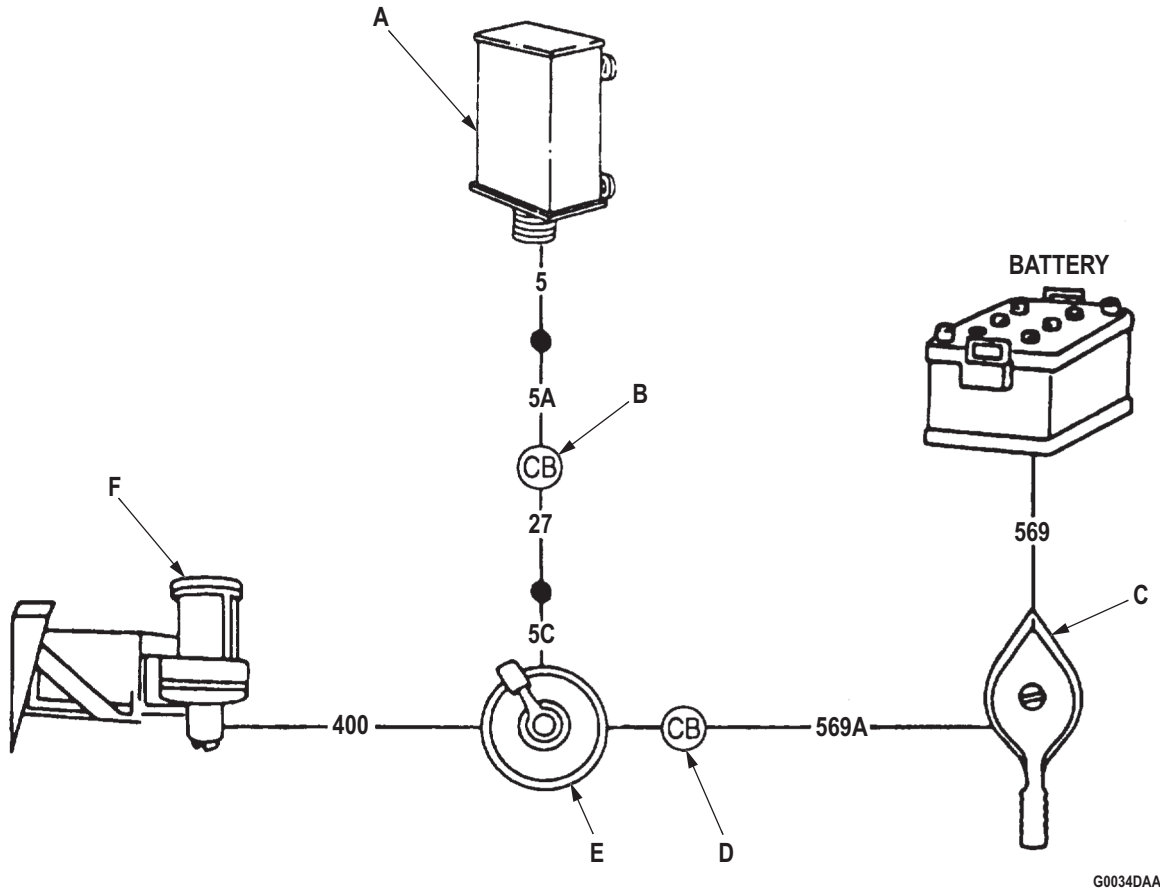

Figure 22. Heating System Components.

INDICATOR, GAUGE, AND WARNING SYSTEM OPERATION

The indicator, gauge, and warning system is comprised of several subsystems:

- A. ENGINE OIL PRESSURE INDICATOR** - Indicates engine oil pressure and receives battery power through circuit 27A. Circuit 36 completes the circuit to ground through the oil pressure transmitter located on the engine block.
- B. FUEL INDICATOR** - Indicates fuel level. Receives battery power through circuit 27A. Circuit 28 or 29, depending on which position fuel selector switch is in, completes the circuit to ground through the oil pressure transmitter located on the engine block.
- C. TRANSMISSION OIL TEMPERATURE INDICATOR** - Indicates transmission oil temperature and receives battery power through circuit 27A. Circuit 324 completes circuit to ground through a temperature sensor located in transmission.
- D. FRONT-WHEEL DRIVE ENGAGEMENT LIGHT** - Informs the operator that front-wheel drive is engaged. The system consists of a normally open pressure switch, which is powered through circuit 27A and an indicator lamp powered through circuit 27A.
- E. HORN SYSTEM** - The horn system consists of an air-operated horn that is controlled by an electric solenoid. The solenoid is powered through circuit 26 and controlled by the horn switch through circuit 25.
- F. SPRING BRAKE WARNING SYSTEM** - Warns the operator that spring brakes are applied. The system consists of normally open pressure switch powered through circuit 37 and an indicator lamp which is powered through circuit 37.
- G. FAILSAFE WARNING SYSTEM** - Intended to give the operator an audible as well as visual signal of a malfunction in one of the primary systems. Power for the system is supplied from the ignition switch through circuit 564. The failsafe module causes an indicator lamp to illuminate and an alarm to sound when air pressure falls below 60 psi (414 kPa) or when parking brake is set.
- H. VOLTMETER** - Indicates system voltage and is connected to batteries through circuit 27A and to chassis ground through instrument panel.
- I. ENGINE COOLANT TEMPERATURE INDICATOR** - Indicates engine coolant temperature and receives battery power through circuit 27A. Circuit 33 completes the circuit to ground through a coolant temperature sensor that reacts to changes in engine coolant temperature by increasing or decreasing the resistance in ground circuit.

INDICATOR, GAUGE, AND WARNING SYSTEM OPERATION - Continued

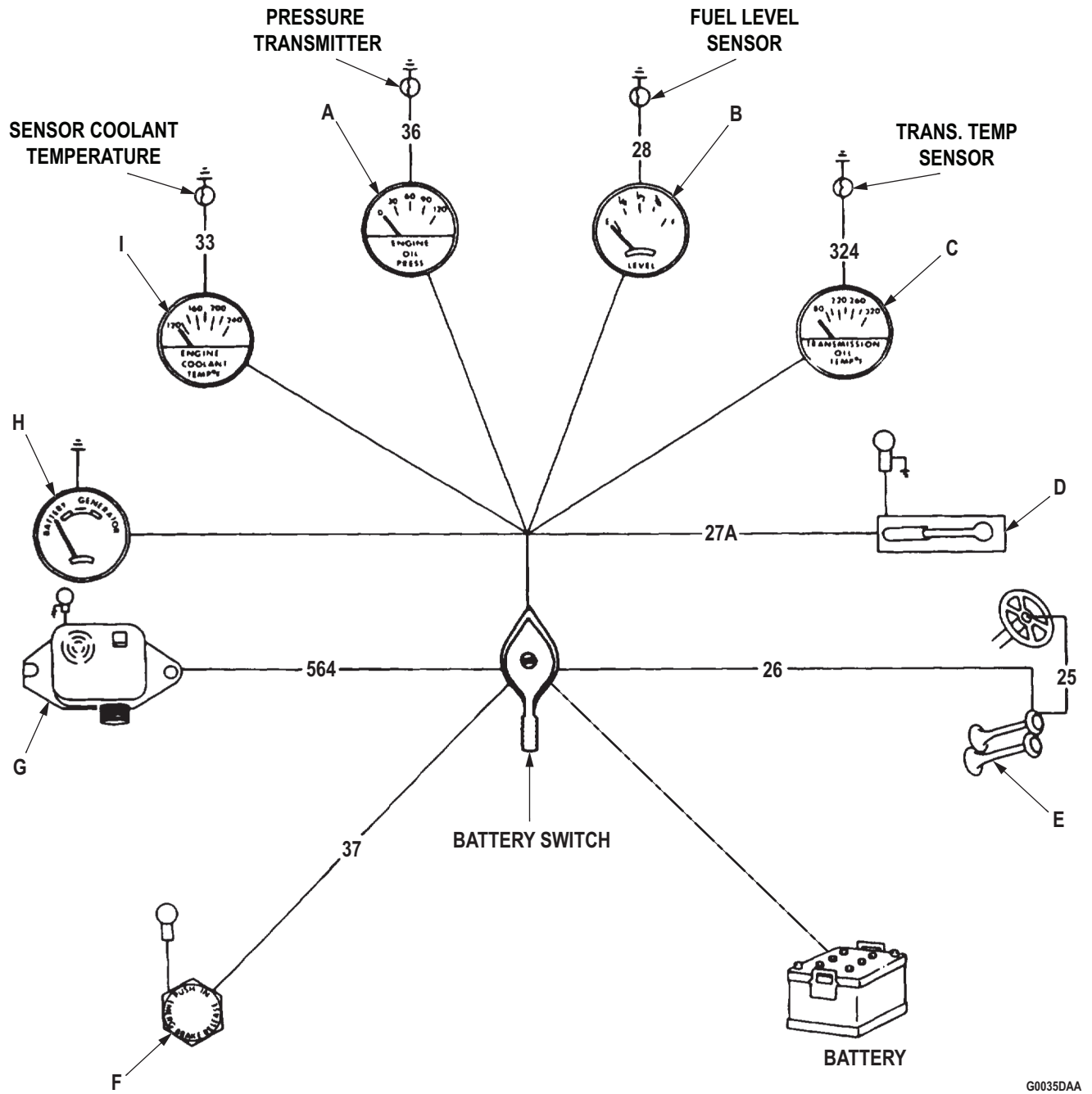

G0035DAA

Figure 23. Indicator, Gauge, and Warning System Components.

TRAILER AND SEMITRAILER CONNECTION SYSTEM OPERATION

The trailer receptacle is identical on all models covered in this manual. The semitrailer receptacle is on the tractor body only.

A. SEMITRAILER RECEPTACLE - M931/A1/A2 and M932/A1/A2 vehicles equipped with a fifth wheel are provided with a semitrailer receptacle. This receptacle provides vehicle lighting, auxiliary power, and a ground circuit for semitrailers.

B. TRAILER RECEPTACLE - Provides vehicle lighting, auxiliary power, and a ground circuit for trailers.

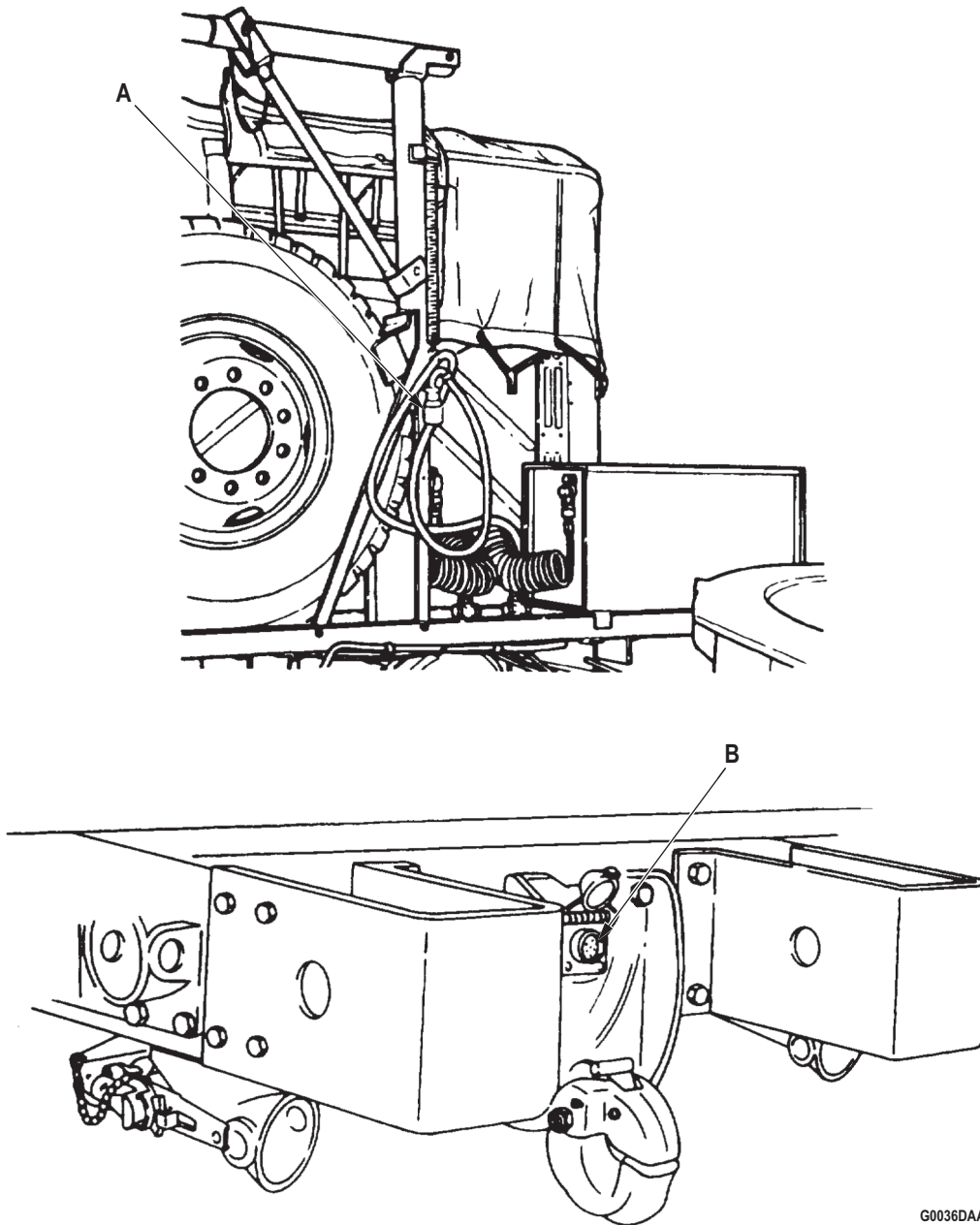

G0036DAA

Figure 24. Trailer and Semitrailer Connection Components.

COMPRESSED AIR AND BRAKE SYSTEM OPERATION

The compressed air and brake system takes filtered air, compresses it, and supplies it to various components that enable the operator to slow down or stop the vehicle. This system also supplies compressed air to air-actuated accessories throughout the vehicle. These components and accessories will be described as part of the following systems:

1. Medium Wrecker Automatic Brake Lock System Operation.
2. Air Pressure Supply System Operation.
3. Secondary Service Airbrake System Operation.
4. Spring Airbrake System Operation.
5. Primary Service Airbrake System Operation.
6. Auxiliary Air-Powered System Operation.
7. Air Venting System Operation.
8. Central Tire Inflation System (CTIS) (M939A2 series vehicles).

MEDIUM WRECKER AUTOMATIC BRAKE LOCK SYSTEM OPERATION

The M936/A1/A2 Medium Wrecker Automatic Brake Lock System locks the service airbrakes when the transfer case PTO lever is engaged. Major components of the automatic brake lock system are:

- A. TRANSFER CASE PTO LEVER** - Opens the brake lock control valve through mechanical linkage when engaged.
- B. BRAKE LOCK CONTROL** - Allows air pressure to flow from secondary air reservoir to pressure regulator and activate variable speed governor.
- C. PRESSURE REGULATOR** - Reduces and regulates system air pressure to 70 psi (483 kPa) for automatic brake lock application.
- D. TREADLE VALVE** - Connects pressure regulator and service airbrakes.

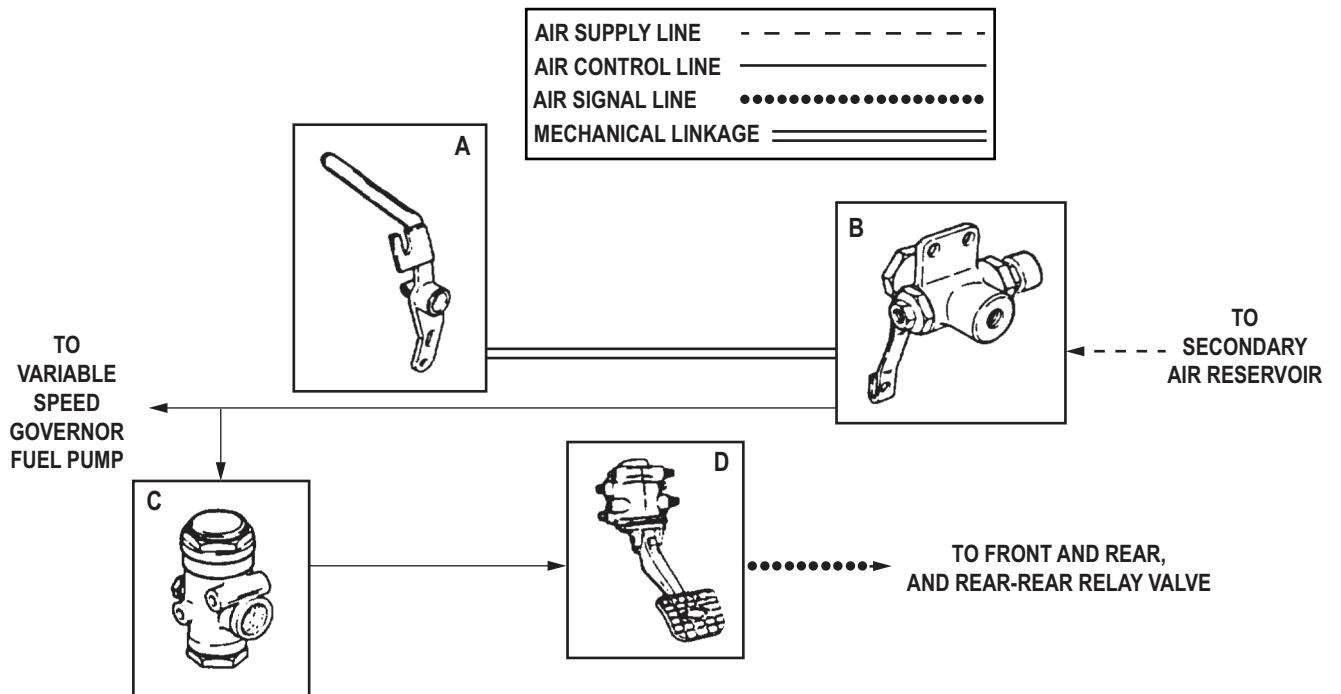

G0037DAA

Figure 25. Medium Wrecker Automatic Brake Lock System Components.

AIR PRESSURE SUPPLY SYSTEM OPERATION

A constant air pressure supply is developed by the compressor which is regulated by the governor to maintain 90 to 120 psi (621 to 827 kPa) for the airbrake system. Moisture within the system is controlled through the use of either the alcohol evaporator or air dryer. The major components of the system are:

A. AIR DRYER - Installed in supply line to wet tank and removes moisture from inlet air to wet tank (M939/A1 air dryer kit installed only).

B. AIR COMPRESSOR - Draws in air from the intake manifold and forces it into brake system and wet tank reservoir.

C. SAFETY VALVE - Located at inlet side of wet reservoir, it prevents pressure buildup by releasing air pressure exceeding 150 psi (1,034 kPa) when the governor fails to regulate air supplied by the compressor.

D. WET TANK RESERVOIR - Performs two functions:

- Traps water in air reservoir to protect other air systems from freezing or corroding.
- Stores reserve air supply enabling operator to make normal stops when engine stalls or compressor fails.

E. PRESSURE PROTECTION VALVE - Performs two functions:

- Allows air pressure to build to 60 to 65 psi (414 to 448 kPa) before supplying air to auxiliary air-powered equipment.
- Closes off auxiliary air system from other systems if an accessory fails and prevents loss of air from secondary reservoir.

F. WET TANK RESERVOIR DRAIN VALVE - Provides a drain for moisture and air from reservoir.

G. AIR DRYER - Removes moisture from inlet air to wet tank (M939A2 only).

H. GOVERNOR - Trips valve inside compressor to regulate flow of air to the system. When pressure builds to 120 to 127 psi (827 to 876 kPa), the governor will close valve.

AIR PRESSURE SUPPLY SYSTEM OPERATION - Continued

ABS EQUIPPED VEHICLES ————
M939A2 ONLY - - - - -

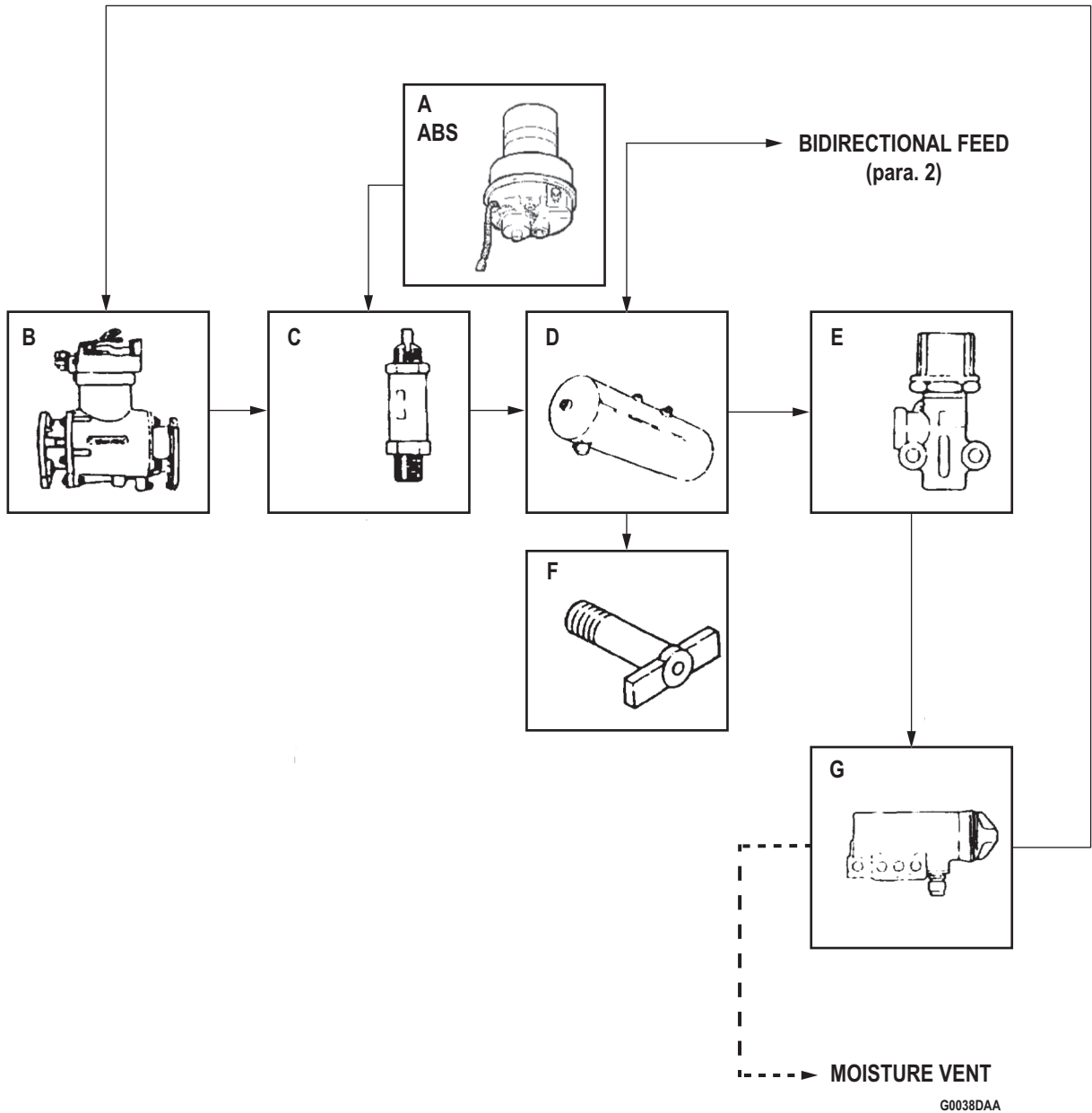

Figure 26. Air Pressure Supply System Components.

AIR PRESSURE SUPPLY SYSTEM OPERATION - Continued

The constant air pressure supply is distributed to the primary service airbrake system and secondary airbrake system through a shutoff and check valve. Air pressure can either be fed from or supplied to another vehicle through the emergency couplings.

A. FRONT EMERGENCY COUPLING - When vehicle is being towed, coupling receives compressed air from towing vehicle's brake system to charge its own brake system.

B. PRIMARY AIR RESERVOIR - Stores sufficient air pressure to allow operator to make normal brake applications if system pressure fails or engine stalls.

C. PRIMARY FEED CUTOFF - Manually-operated valve used to isolate pressure leaks in primary air system from draining wet tank (TM 9-2320-272-10).

D. PRIMARY AIR RESERVOIR CHECKVALVE - Prevents backflow of air from primary tank if wet system develops a leak.

E. SECONDARY FEED CUTOFF - Manually-operated valve used to isolate pressure leaks in secondary air system from draining wet tank (TM 9-2320-272-10).

F. SECONDARY AIR RESERVOIR CHECKVALVE - Prevents backflow of air from secondary tank if wet system develops a leak.

G. REAR EMERGENCY COUPLING - When towing another vehicle, coupling allows pressurized air from wet tank to charge towed vehicle's wet tank.

H. SECONDARY AIR RESERVOIR - Stores enough air pressure in case constant pressure system fails or engine stalls. The operator can make normal brake application before running out of air.

I. PRESSURE PROTECTION VALVE - Performs two functions:

- Allows air pressure to build to 60 to 65 psi (414 to 444 kPa) before supplying air to auxiliary air-powered equipment.
- Closes off auxiliary air system from other systems if an accessory fails and prevents loss of air from secondary reservoir.

AIR PRESSURE SUPPLY SYSTEM OPERATION - Continued

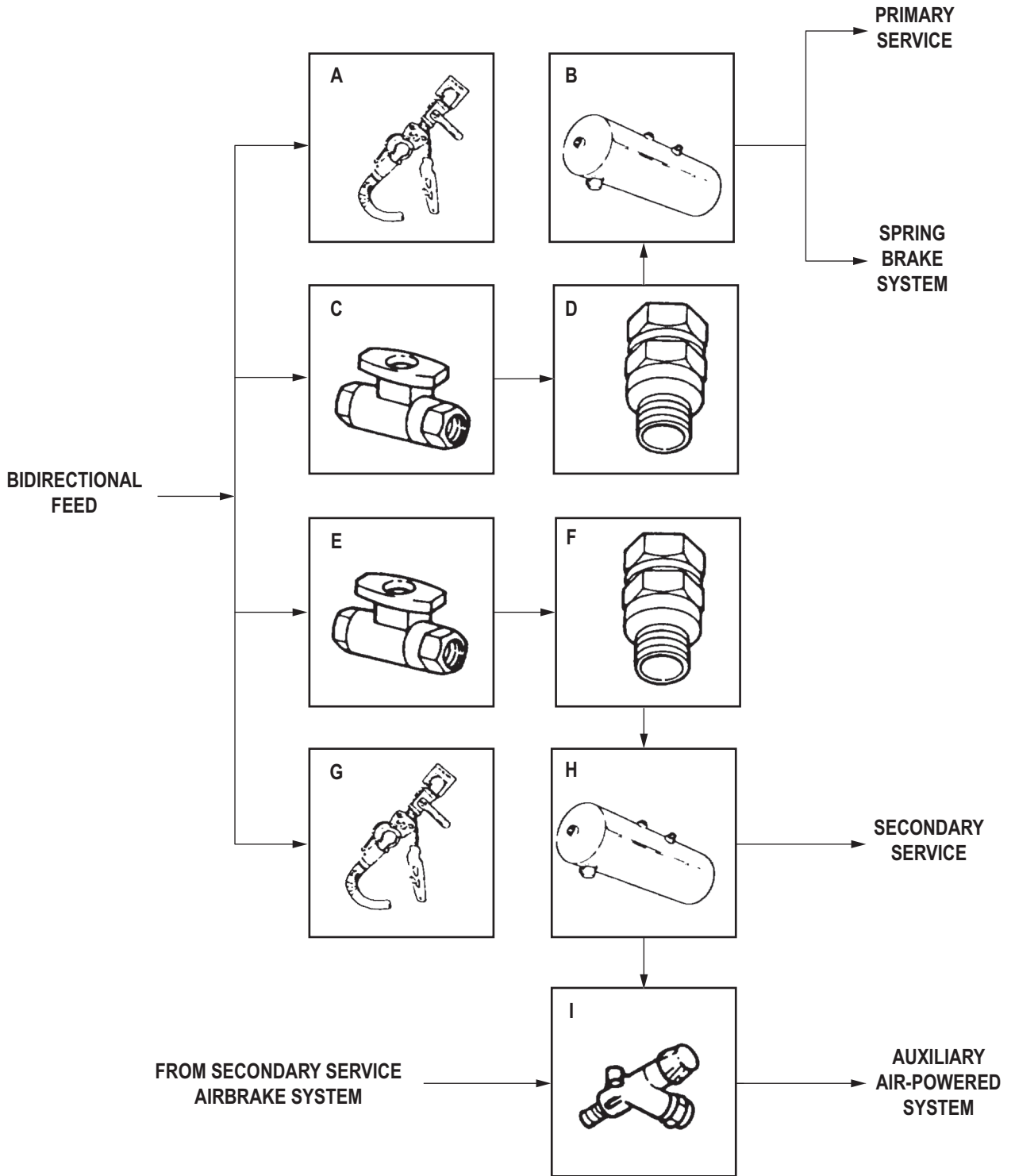

G0039DAA

Figure 27. Constant Air Pressure Supply System Components.

SECONDARY SERVICE AIRBRAKE SYSTEM OPERATION

1. The secondary service airbrake system is made up of two subsystems:
 - a. Secondary constant pressure system provides continuous air pressure to:
 - Pedal valve
 - Rear relay valve
 - Spring brake air reservoir
 - Spring parking brake valve
 - b. Secondary signal system serves three functions:
 - Contains air pressure only when operator steps on brake pedal.
 - Is regulated by various valves to control amount of braking.
 - Provides pressure to apply rear two service brakes and intermediate and rear axles stamped with B. Service brakes on rear axle are piggybacked to spring brakes, but operate independently of them.
2. The secondary constant pressure system is made up of the following components:
 - A. LOW AIR PRESSURE SWITCH** - Activates warning buzzer and warning lights when air pressure goes below 60 psi (414 kPa).
 - B. PEDAL VALVE** - Allows air pressure from secondary constant pressure system to flow into secondary signal system when operator depresses brake pedal.
 - C. SECONDARY AIR PRESSURE GAUGE** - Indicates amount of air pressure in secondary system.
 - D. ONE-WAY CHECKVALVE** - Allows air pressure to flow into secondary reservoir, but prevents it from coming out if constant pressure system fails or engine stalls.
 - E. SECONDARY AIR RESERVOIR** - Stores enough air pressure so the operator can make five normal brake applications before running out of air if constant pressure fails or engine stalls.
 - F. INTERMEDIATE REAR BRAKE CHAMBERS** - Converts air pressure to mechanical force which applies intermediate rear service brake.
 - G. DOUBLE CHECK VALVE NO. 1** - Serves two functions:
 - Allows system to receive signal pressure from either pedal valve or, when towed, from brake system of towing vehicle.
 - Serves as a tee between front and rear primary signal lines.
 - H. SECONDARY AIR RESERVOIR DRAIN VALVE** - Provides a drain for moisture and air from secondary air reservoir.
 - I. FRONT RELAY VALVE** - Boosts signal air to rear brake chambers; regulates air pressure to rear brake chambers so operator has control over amount of braking; and releases air pressure to rear brake chambers directly to vent when brake pedal is released.
 - J. STOPLIGHT SWITCH** - As the brake pedal is depressed, switch receives an air pressure signal at electrical contacts which close to activate circuits to taillights.
 - K. DOUBLE CHECK VALVE NO. 2** - Allows either primary or secondary signal air pressure to activate stoplight switch while keeping the two systems separate.
 - L. REAR-REAR BRAKE CHAMBERS** - Converts air pressure to mechanical force which applies rear-rear brakes.

SECONDARY SERVICE AIRBRAKE SYSTEM OPERATION - Continued

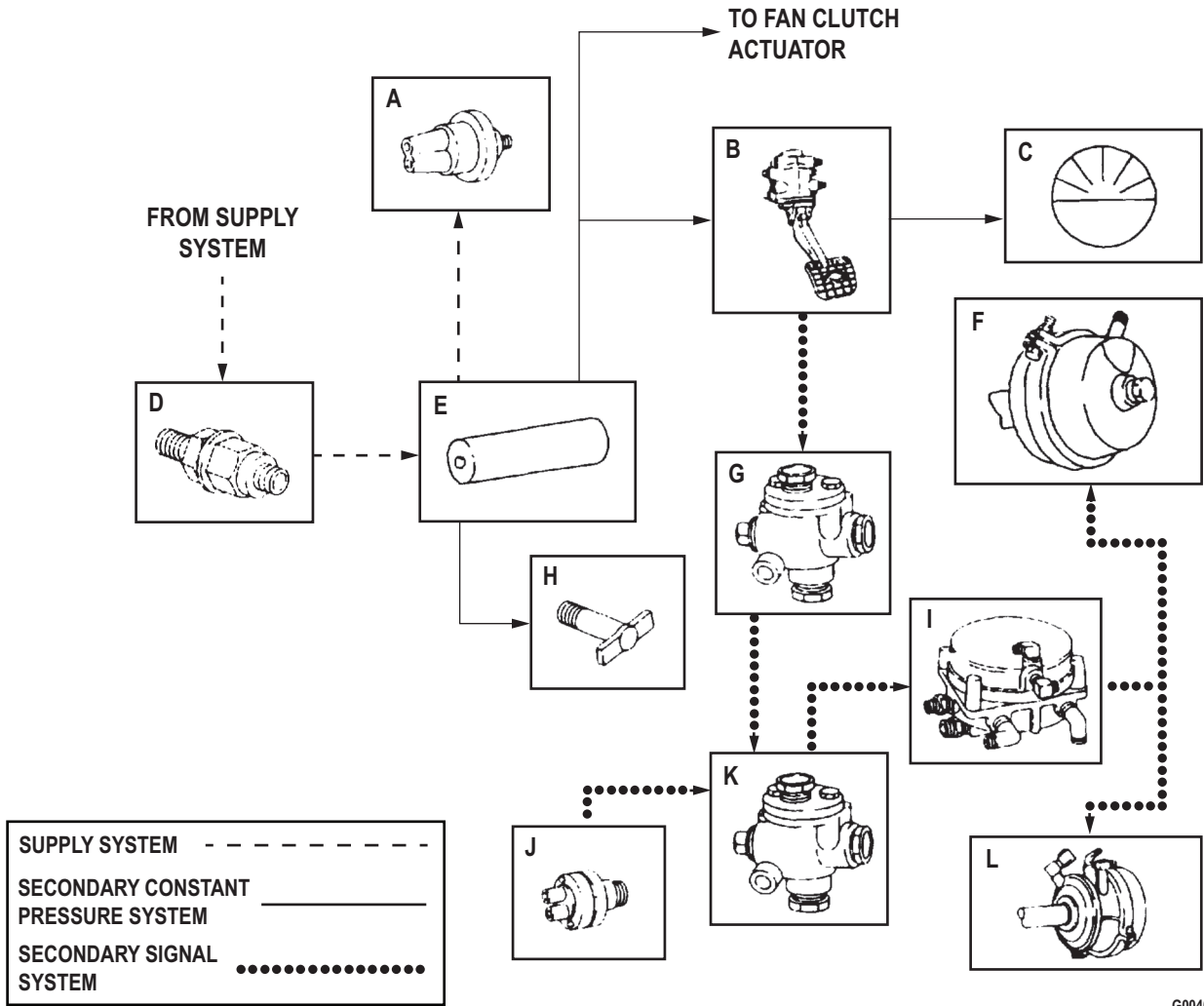

Figure 28. Secondary Service Airbrake System Components.

SPRING AIRBRAKE SYSTEM OPERATION

The spring airbrake system applies rear brakes when vehicle parking brake is applied or in event of a major brake failure. The spring brake is located on one of the two service brake chambers at each rear wheel. Major components of the spring airbrake system are:

- A. SPRING BRAKE WARNING LIGHT SWITCH** - Activates warning light when spring brakes are engaged.
- B. SPRING BRAKE RELEASE CONTROL VALVE** - Pushed in to release spring brakes independently of mechanical parking brake. Control is also used to release spring brakes in order to test and adjust mechanical brake.
- C. DOUBLE CHECK VALVE NO. 4** - Allows spring brake air pressure to come from either release control valve or spring parking brake valve directly to double check valve No. 3.
- D. INTERMEDIATE FRONT SPRING BRAKE CHAMBER** - Contains a large spring which applies rear brakes when spring brake air pressure is released.
- E. ONE-WAY CHECKVALVE** - Allows air pressure to flow into spring brake reservoir, but prevents it from coming out if constant pressure system or primary system fails.
- F. SPRING BRAKE AIR RESERVOIR** - Stores enough air pressure to release spring brakes for emergency operation in event of primary or secondary air system failure.
- G. QUICK-RELEASE VALVE** - Releases spring brake air pressure directly to vent if parking brake has been set or brake system fails.
- H. SPRING BRAKE VALVE** - Automatically sets spring brakes when parking brake is set. Valve can be released independently of parking brake when spring brake control valve is pushed in.
- I. SPRING BRAKE RESERVOIR DRAIN VALVE** - Provides a drain for moisture and air from spring brake reservoir.
- J. DOUBLE CHECK VALVE NO. 3** - Allows spring brake air pressure to come from either release control valve or spring parking brake valve directly to double check valve No. 4.
- K. REAR-BEAR SPRING BRAKE CHAMBER** - Contains a large spring which applies rear brakes when spring brake air pressure is released.

SPRING AIRBRAKE SYSTEM OPERATION - Continued

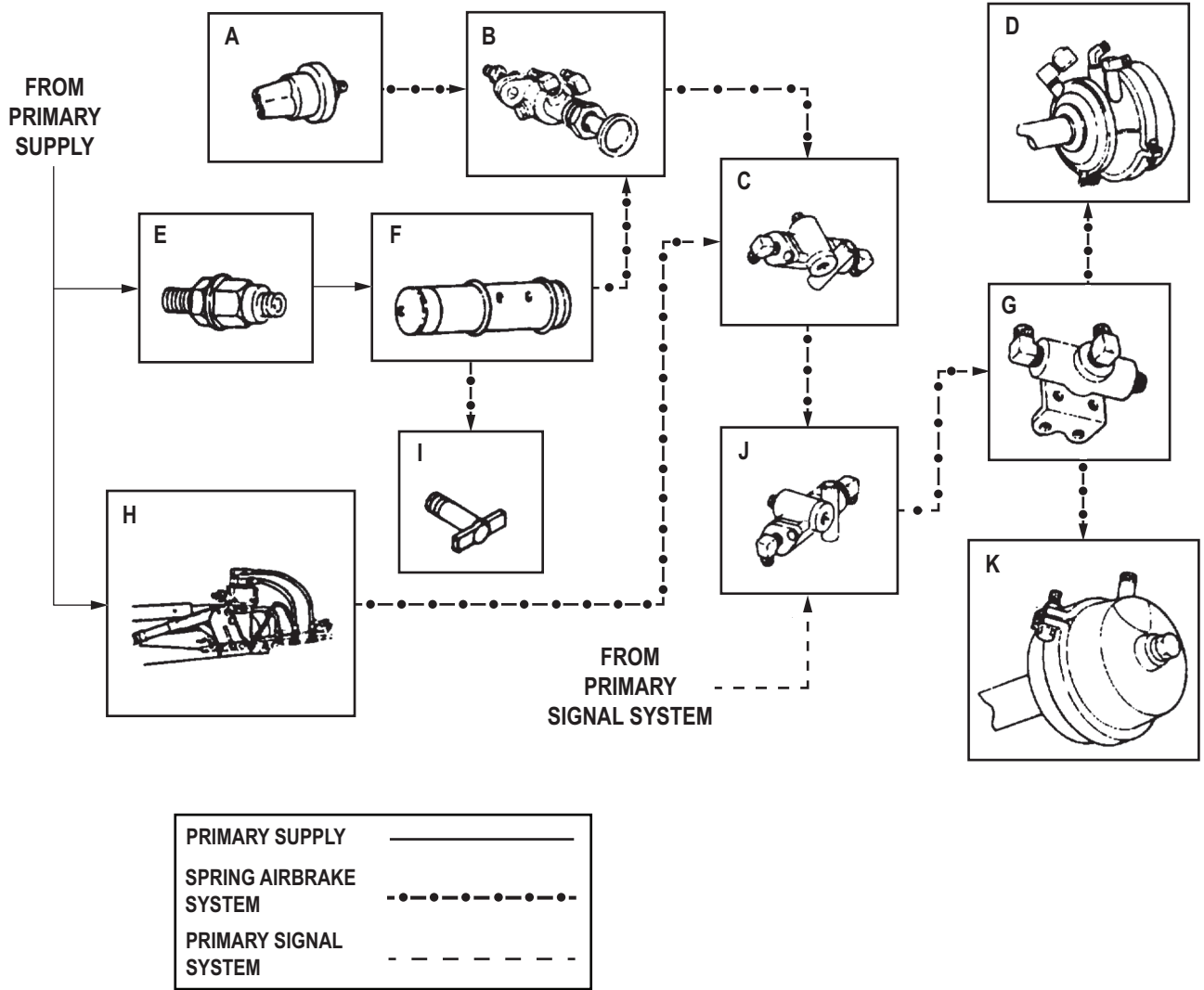

G0041DAA

Figure 29. Spring Airbrake System Components.

PRIMARY SERVICE AIRBRAKE SYSTEM OPERATION

1. The primary service airbrake system is made up of two subsystems:
 - a. Primary constant pressure system provides continuous air pressure to:
 - Pedal valve
 - Rear relay valve
 - Spring brake air reservoir
 - Spring parking brake valve
 - b. Primary signal system serves three functions:
 - Contains pressure only when operator steps on brake pedal.
 - Is regulated by various valves to give operator control over amount of braking.
 - Provides pressure to apply front service brakes and the front two service brakes on intermediate and rear axles stamped with an A. Service brakes on the intermediate axle are piggybacked to spring brakes, but operate independently of them.
2. The primary constant pressure system is made up of the following components:
 - A. PRIMARY AIR PRESSURE GAUGE** - Indicates amount of air pressure in primary system.
 - B. LIMITING VALVE** - Serves three functions:
 - Regulates signal air pressure going to front brake chambers so rear brakes are applied first.
 - Regulates signal air pressure to front brake chambers so operator has control over amount of braking.
 - Releases air pressure in front brake chambers directly to vent in the valve when brake pedal is released.
 - C. FRONT BRAKE CHAMBERS** - Convert air pressure to mechanical force which applies front service brakes.
 - D. PRIMARY RESERVOIR LOW AIR PRESSURE SWITCH** - Activates warning buzzer and warning light when air pressure goes below 60 psi (414 kPa).
 - E. PEDAL INTO VALVE** - Allows air pressure from primary constant pressure system to flow into primary signal system when operator depresses brake pedal.
 - F. DOUBLE CHECK VALVE NO. 1** - Serves two functions:
 - Allows system to receive signal pressure from either pedal valve or, when towed, from brake system of towing vehicle.
 - Serves as a tee between front and rear primary signal lines.
 - G. FRONT SERVICE COUPLING** - When vehicle is being towed, coupling is connected to towing vehicle so the brake systems of the two vehicles work together.
 - H. ONE-WAY CHECKVALVE** - Allows air pressure to flow into primary reservoir, but prevents it from coming out if constant pressure system fails or engine stalls.
 - I. PRIMARY AIR RESERVOIR** - Stores enough air pressure so the operator can make five normal brake applications before running out of air if constant pressure fails or engine stalls.
 - J. DOUBLE CHECK VALVE NO. 2** - Allows either primary or secondary signal air pressure to activate stoplight switch while keeping the two systems separate.
 - K. STOPLIGHT SWITCH** - As brake pedal is depressed, switch receives an air pressure signal which closes electric contacts turning on stoplight.
 - L. REAR SERVICE COUPLING** - When towing another vehicle, coupling is connected to towed vehicle so the brake systems of the two vehicles work together.
 - M. INTERMEDIATE FRONT BRAKE CHAMBERS** - Converts air pressure to mechanical force which applies intermediate rear service brake.
 - N. PRIMARY RESERVOIR DRAIN VALVE** - Provides a drain for moisture and air from primary air reservoir.
 - O. REAR RELAY VALVE** - Serves three functions:
 - Boosts signal air pressure to rear brake chambers. Air signal from brake pedal opens valve to route constant air pressure to rear brake chambers.
 - Regulates signal air pressure from brake pedal to rear brake chambers so operator has control over amount of braking. Regulates amount of constant air pressure going to brake chambers as the operator depresses the pedal.
 - Releases air pressure in rear brake chamber directly to vent system when brake pedal is released.

PRIMARY SERVICE AIRBRAKE SYSTEM OPERATION - Continued

P. REAR FRONT BRAKE CHAMBERS - Converts air pressure to mechanical force which applies rear service brakes.

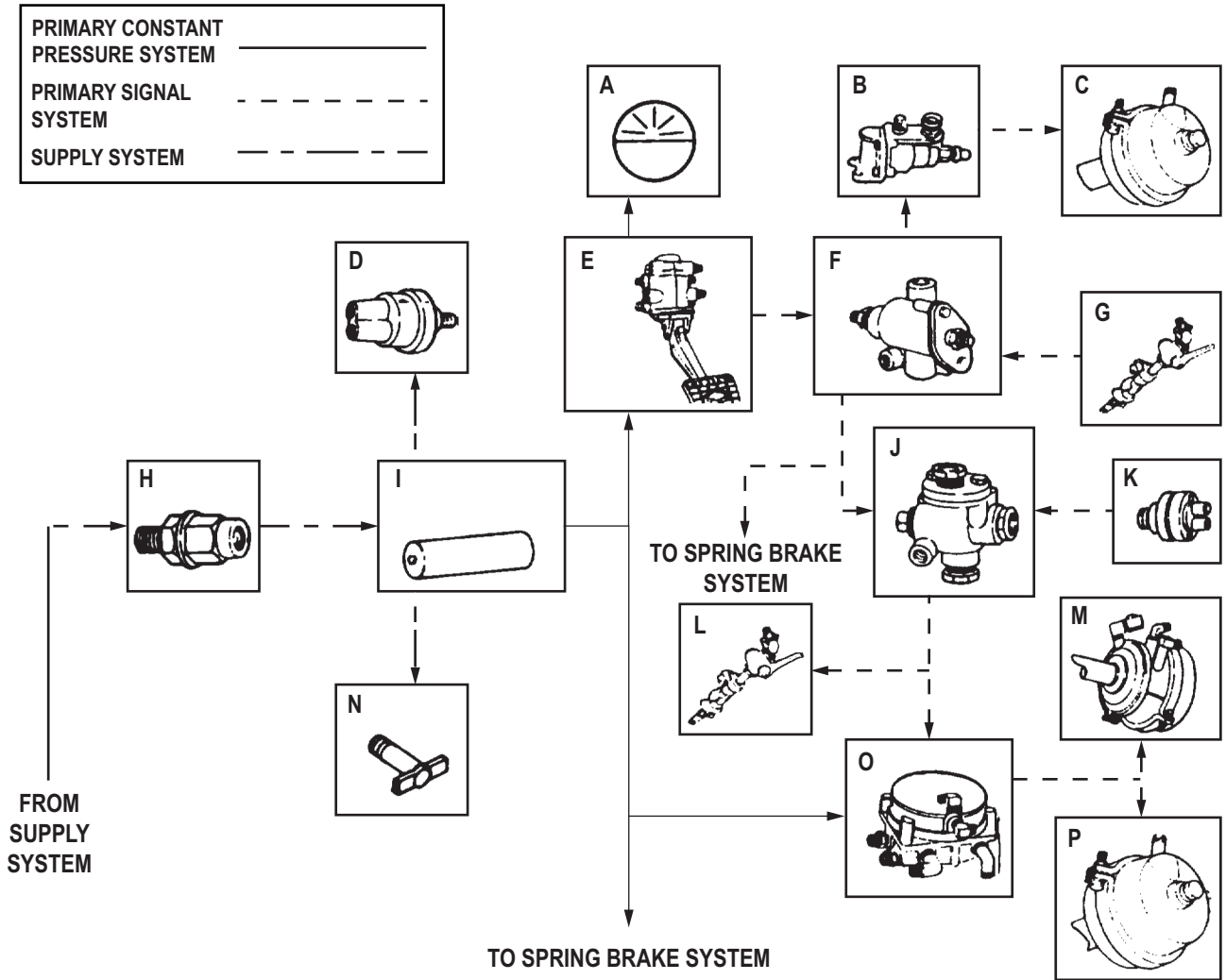

G0042DAA

Figure 30. Primary Service Airbrake System Components.

AUXILIARY AIR-POWERED SYSTEM OPERATION

The auxiliary air-powered system consists of air-actuated vehicle accessories. All of these accessories receive air pressure through the accessory manifold and off the pressure protection valve with the exception of the horns.

Components of the auxiliary air-powered system are:

- A. WINDSHIELD WIPER CONTROL SWITCH** - Opens air pressure valve in wiper motor to operate wipers.
- B. WINDSHIELD WIPER MOTOR** - Air-actuated motor powers windshield wipers.
- C. WINDSHIELD WASHER CONTROL** - Spring-loaded valve that allows air pressure to force washer fluid from washer reservoir to windshield.
- D. WINDSHIELD WASHER RESERVOIR** - Container for windshield washer fluid.
- E. ACCESSORY MANIFOLD** - Receives air pressure from the pressure protection valve and distributes it to the various accessories.
- F. FRONT-WHEEL DRIVE LOCK-IN SWITCH** - Air-actuated switch that engages front-wheel drive when transfer case is in HIGH.
- G. WINDSHIELD WASHER NOZZLES** - Direct washer fluid on windshield.
- H. GOVERNOR** - Serves as a tee between accessory manifold and horn relay valve. It also signals the air compressor to stop compressing air for the supply system when operating pressure has been reached.
- I. TRANSFER CASE AIR SHIFT CYLINDER** - Engages front-wheel drive when it receives air pressure from lock-in switch or engagement control valve.
- J. FRONT AXLE ENGAGEMENT CONTROL VALVE** - Operates off cam, on transfer case shift linkage so front-wheel drive engages automatically when transfer case is put into LOW.
- K. HORN RELAY VALVE** - Electrical signal from horn button on steering wheel opens valve in horn relay, allowing air pressure to sound horns.
- L. HORNS** - Receive air pressure from horn relay valve to sound off.

AUXILIARY AIR-POWERED SYSTEM OPERATION - Continued

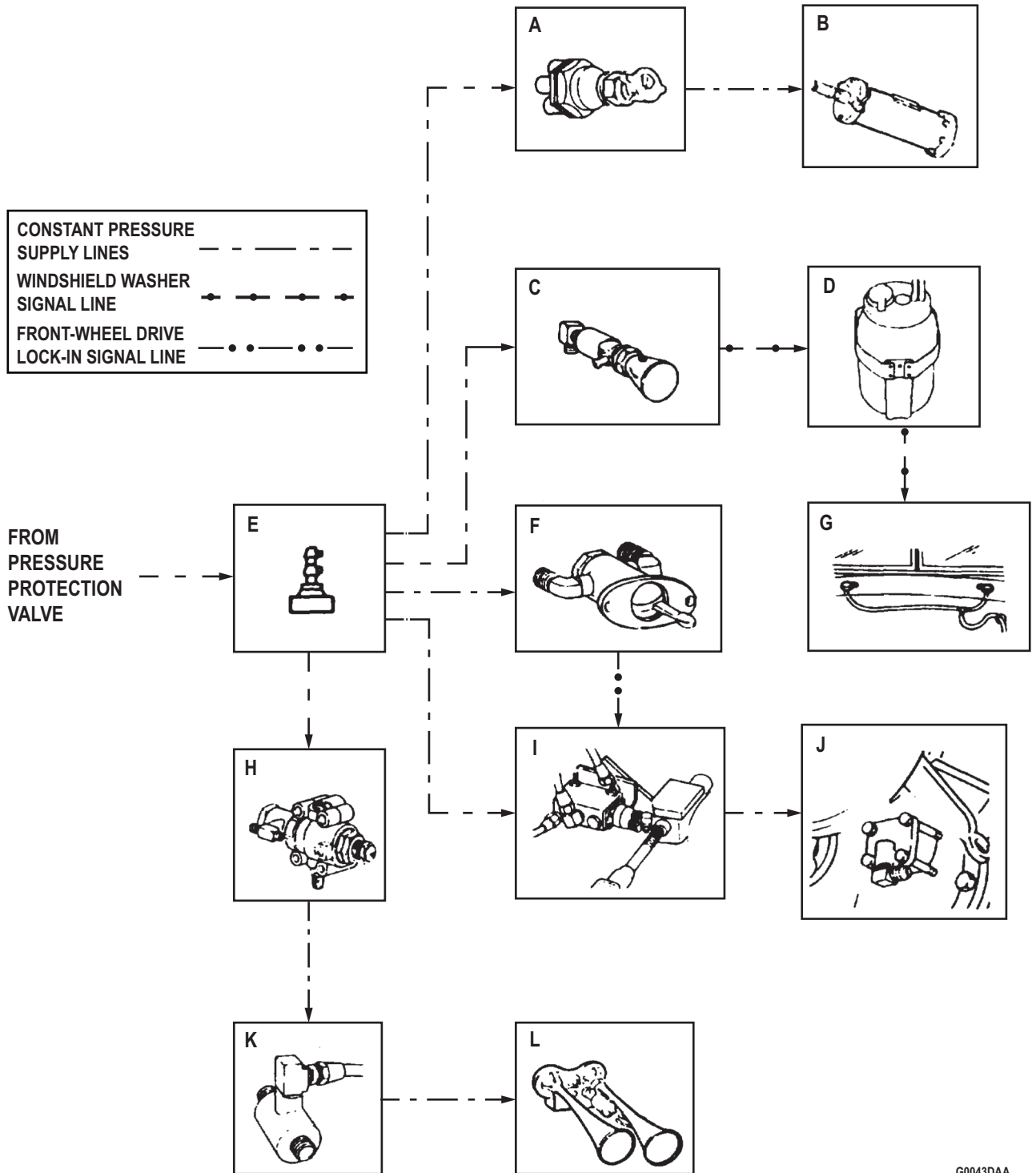

G0043DAA

Figure 31. Auxiliary Air-Powered System Components.

AIR VENTING SYSTEM OPERATION

The air venting system vents air from brake system and powertrain and fuel vapors from fuel system into air intake stack where it is released into the atmosphere. The components of the air venting system are:

- A. SPRING BRAKE RELEASE CONTROL VALVE** - This valve functions as an override when a failure in the air supply system (causing spring brakes to engage) occurs. When valve is manually pushed in, emergency air is supplied to the spring brake chambers. This releases the spring brakes, allowing vehicle movement.
- B. PEDAL VALVE** - Vents primary or secondary signal air pressure when pedal is released.
- C. FRONT BRAKE CHAMBER VENT** - Vents air pressure inside chambers when pedal valve is released.
- D. LIMITING VALVE** - Vents signal air pressure going to front brake chambers so rear brakes apply first.
- E. STEP BOX QUICK-RELEASE VALVE** - Vents air pressure from spring brake chambers when parking brake valve has been actuated.
- F. REAR BRAKE CHAMBERS** - Vents ports on chambers to prevent air pressure buildup.
- G. RELAY VALVES** - Vents air pressure in rear brake chambers directly to intake tube when brake pedal is released. Vents signal air pressure through upper port in valve.
- H. AIR INTAKE STACK** - Venting point for the vent system.
- I. TRANSMISSION VENT** - Vents internal air pressure buildup due to internal heat.
- J. SPRING PARKING BRAKE VALVE** - Vents air pressure from air and double check valves No. 3 and No. 4.
- K. TRANSFER CASE VENT** - Vents internal air pressure buildup due to internal heat.
- L. FUEL TANK VENTS** - Vent fuel vapors to prevent partial vacuum from stopping fuel flow.

AIR VENTING SYSTEM OPERATION - Continued

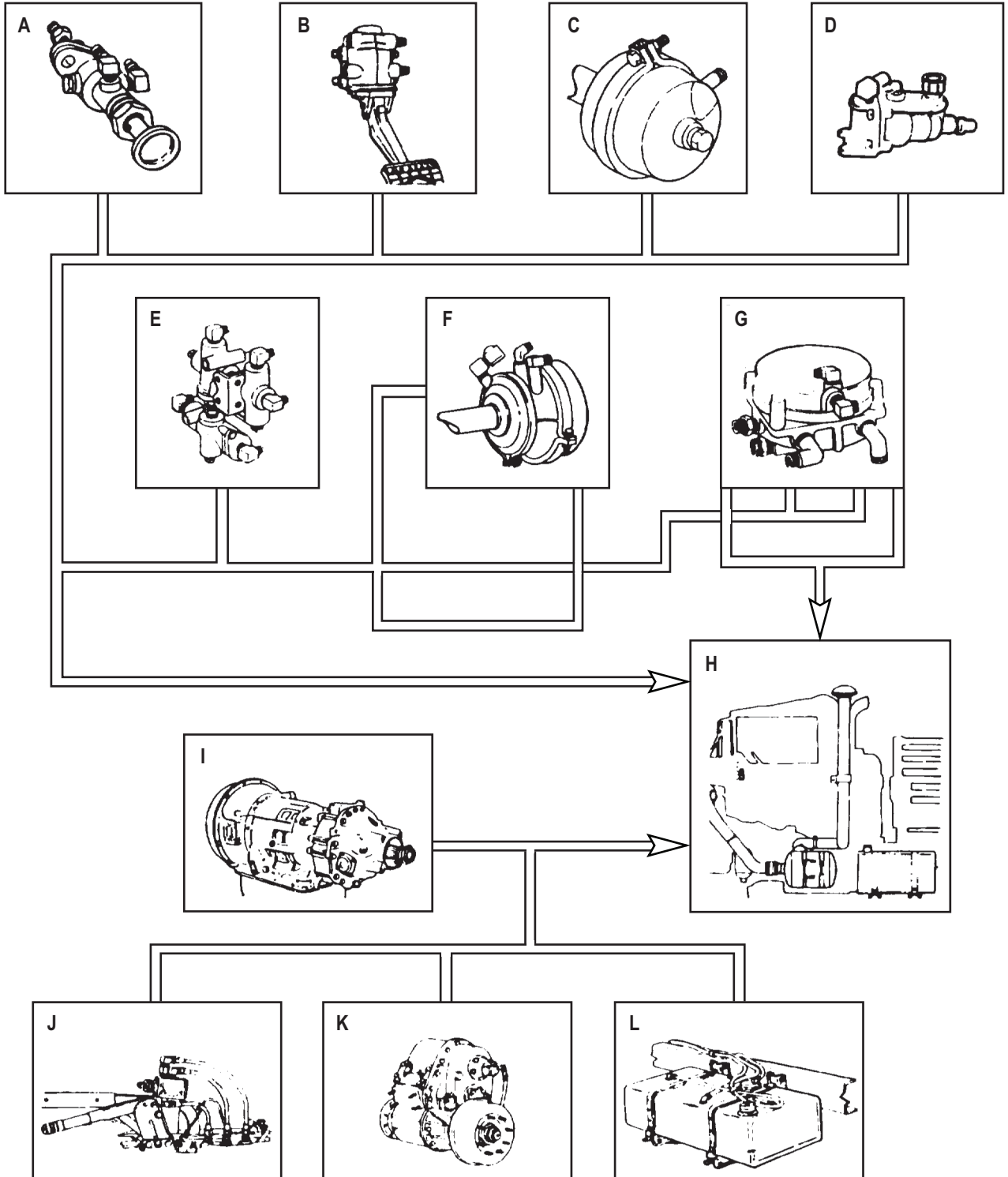

G0044DAA

Figure 32. Air Venting System Components.

CENTRAL TIRE INFLATION SYSTEM (CTIS) (M939A2 SERIES VEHICLES)

The M939A2 Central Tire Inflation System (CTIS) uses the vehicle's air compressor system, pneumatic valves, and a microprocessor to adjust tire pressure according to mission demands. The system needs clean, dry air to maintain itself. The turbocharger and aftercooler help supply more compressed air when the vehicle is loaded and operating at high rpm.

Compressed air enters air dryer, which filters dirt and ejects moisture from air. System air then enters the wet tank and is available to airbrakes and CTIS. The brake system is protected by an 85 psi (138 kPa) pressure switch in CTIS air line. If wet tank air pressure measures below 85 psi (138 kPa), the CTIS shuts down until pressure switch measures 120 psi (827 kPa).

Air is then routed to pneumatic controller, which consists of three valves and solenoids working in conjunction with the Electronic Control Unit (ECU). The ECU is a microprocessor programmed to issue commands based on information it receives from pressure switch, pressure transducer (which tests tires pressure), and speed signal generator (which monitors vehicle speed). The commands are electrically received by the pneumatic controller, which affects inflation or deflation of tires through quick-exhaust valves.

Six wheel valves isolate tire pressure during normal operation. They also open to allow tire inflation or tire deflation through three quick-exhaust valves.

The system is automatic. The operator only needs to select the mode that best accomplishes the mission.

The CTIS is common to all M939A2 series vehicles. This system maintains tire air pressure depending on which road type is selected. If this setting is changed, tires will automatically inflate or deflate to the new setting.

A. ELECTRONIC CONTROL UNIT (ECU) - Contains CTIS selector panel so that operator can change tire inflation during vehicle operation.

B. AIR PRESSURE SWITCH - Protects air brake system for a minimum supply of 85 psi (586 kPa) of air.

C. AIR DRYER AND FILTER - Separates moisture from compressed air system and filters impurities from compressed air before they enter CTIS.

D. EXHAUST VALVES - Exhaust air from tires during deflation.

E. WHEEL VALVES - Isolate air pressure in tires during normal operation and for tire removal.

F. SPEED SIGNAL GENERATOR - Signals ECU to automatically inflate CTIS when vehicle speed exceeds the top speed setting for the selected mode by 10 mph (16 kmh).

G. PNEUMATIC CONTROLLER - Directs air pressure according to ECU commands.

H. PRESSURE TRANSDUCER - Mounted in pneumatic controller, it measures tire pressure and sends information to ECU.

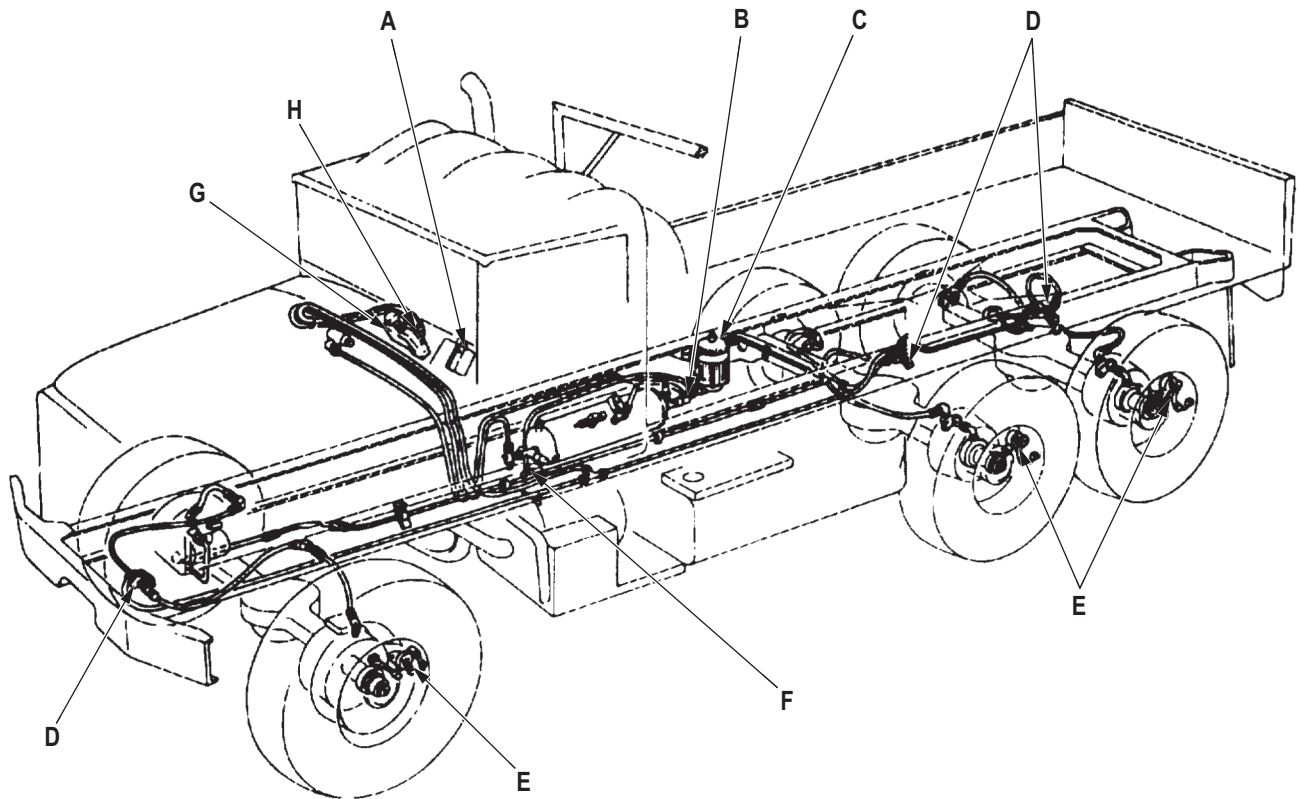
CENTRAL TIRE INFLATION SYSTEM (CTIS) (M939A2 SERIES VEHICLES) - Continued

G0045DAA

Figure 33. Central Tire Inflation System Components.

HYDRAULIC SYSTEM OPERATION

Oil pressure (hydraulics) is used to provide operating power for the auxiliary equipment on the vehicles covered in this manual. The components that provide hydraulic power are discussed in the following order:

1. Front Winch Hydraulic System Operation.
2. Rear Winch Hydraulic System Operation.
3. Dump Body Hydraulic System Operation.
4. Medium Wrecker Crane Hydraulic System Operation.

FRONT WINCH HYDRAULIC SYSTEM OPERATION

A front winch is installed on M925/A1/A2, M928/A1/A2, M930/A1/A2, M932/A1/A2, and M936/A1/A2 series vehicles. The front winch hydraulic system converts mechanical power at the winch drive motor. The basic operating principles are the same for each model. Major components of this system are:

A. WINCH CONTROL LEVER - An operator control that determines the hydraulic oil pressure flow from the control valve to the winch motor. The flow of this oil determines the direction the winch drum will turn.

B. TRANSMISSION PTO - Uses transmission driving power to provide mechanical driving power for the hydraulic pump.

C. PTO DRIVESHAFT - Transmits mechanical power from PTO to the hydraulic pump.

D. HYDRAULIC PUMP - Driven by PTO driveshaft, it draws oil from the oil reservoir through hydraulic hoses, then pressurizes and directs this oil to the control valve.

E. OIL FILTER - Filters used or bypassed oil from the control valve before it returns to the hydraulic oil reservoir.

F. HYDRAULIC OIL RESERVOIR - Storage tank for hydraulic oil.

G. CONTROL VALVE - Four-port valve accepts pressurized oil from the hydraulic pump and directs this oil to the winch motor. It also directs oil returning from the winch back to the oil reservoir. The flow of this oil from the valve determines the directional drive of the winch motor.

H. WINCH MOTOR - Converts hydraulic power into mechanical power as hydraulic oil is forced through the winch motor.

I. CLUTCH LEVER - Manual control that engages winch drum gear to drive gear of winch motor.

J. TRANSMISSION PTO CONTROL - A manually-operated control lever located inside the cab that permits engagement or disengagement of the transmission PTO.

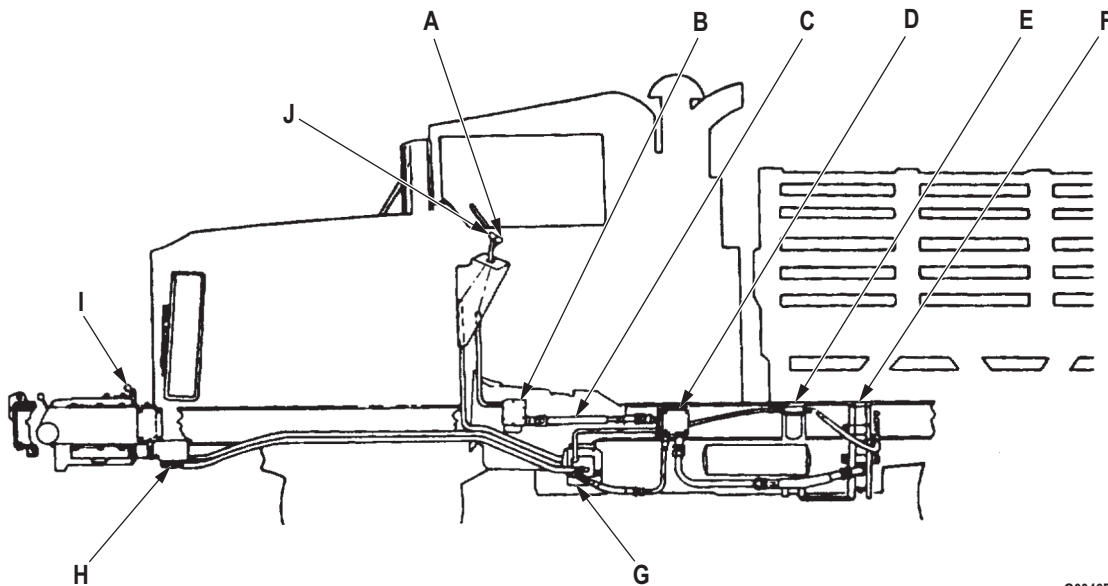

G0046DAA

Figure 34. Front Winch Hydraulic System Components.

REAR WINCH HYDRAULIC SYSTEM OPERATION

A rear winch is installed only on the M936/A1/A2 medium wrecker. It is used primarily to rescue vehicles that have become deeply mired. The rear winch hydraulic system converts mechanical power of the engine into fluid power through use of the hydraulic pump and back into mechanical power at the winch drive motor. The major components of the rear winch hydraulic system are:

- A. PTO DRIVESHAFT** - Transmits mechanical driving power from PTO to the hydraulic pump.
- B. HYDRAULIC PUMP** - Draws oil from hydraulic oil reservoir and directs it to the rear winch control valve and winch drive motor.
- C. OIL FILTER** - Filters used or bypassed oil from the control valve before it returns to the hydraulic oil reservoir.
- D. HYDRAULIC OIL RESERVOIR** - Storage tank for hydraulic oil.
- E. TORQUE CONTROL LEVER** - Controls the operating gear ratio of the winch drive motor. Lever is pulled outward to HIGH for heavy loads or pushed inward to LOW for light loads.
- F. WINCH DIRECTIONAL CONTROL LEVER** - Manually-operated lever that controls the wind and unwind direction of the rear winch drum. Lever does this by opening and closing the directional control valve to the winch motor, and reversing the direction of pressurized hydraulic fluid. Lever is pushed inward to wind and pulled outward to unwind winch cable.
- G. DIRECTIONAL CONTROL VALVE** - Receives pressurized hydraulic oil from the hydraulic pump and directs it to the winch motor. The flow of hydraulic oil to and from this control valve provides forward or reverse driving power to the winch motor. Valve also returns used oil back to the hydraulic oil reservoir from the winch.
- H. TORQUE CONTROL VALVE** - Hydraulically controls the hydraulic oil pressure to engage rear winch drum clutch in high or low gear range.
- I. WINCH MOTOR** - Converts hydraulic power back into mechanical power needed to turn the rear winch drum.
- J. CONTROL LINKAGE** - Connects transfer case PTO control to transfer case PTO.
- K. TRANSFER CASE PTO CONTROL** - A manually-operated control lever located inside the cab that permits engagement or disengagement of the PTO.
- L. TRANSFER CASE PTO** - Uses driving power of the transfer case to provide mechanical driving power for the hydraulic pump.

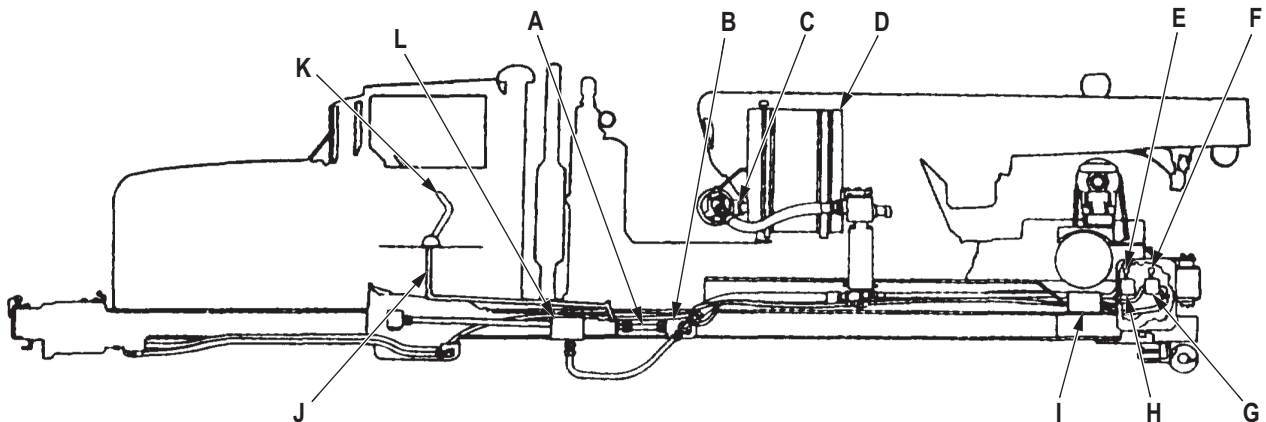

G0047DAA

Figure 35. Rear Winch Hydraulic System Components.

DUMP BODY HYDRAULIC SYSTEM OPERATION

The dump body is installed on M929/A1/A2 and M930/A1/A2 model vehicles. These models are used to transport and deposit cargo. The dump body hydraulic system converts mechanical power from the engine into fluid power through use of the hydraulic pump. The pump draws fluid from the oil reservoir and then forces it into the control valve. This hydraulic pressure raises and lowers the dump body. Major components of the dump body hydraulic system are:

- A. PTO DRIVESHAFT** - Transmits mechanical driving power from the PTO to the hydraulic pump.
- B. HYDRAULIC PUMP** - Driven by the PTO driveshaft, it draws oil from oil reservoir through hydraulic hoses, then pressurizes and directs it to the control valve.
- C. HYDRAULIC OIL RESERVOIR** - Storage tank for hydraulic oil.
- D. DUMP BODY SAFETY LATCH** - Hydraulically-operated in conjunction with the dump body control lever, the safety latch locks dump body in the lowered position and releases it when the control lever is pulled back to the raised position.
- E. DUMP BODY CYLINDER ASSEMBLY** - Consists of two piston-type hydraulic cylinder hoists. Assembly raises and lowers dump body with hydraulic oil, forcing the cylinder upward or downward.
- F. OIL FILTER** - Filters used or bypassed oil from the control valve before it returns to the hydraulic oil reservoir.
- G. CONTROL VALVE** - Four-port valve accepts pressurized oil from the hydraulic pump and directs oil pressure flow from control valve to the hydraulic cylinders. It also directs oil returning from the hydraulic cylinders back to the hydraulic oil reservoir.
- H. DUMP BODY CONTROL LEVER** - An operator control that determines the hydraulic oil pressure flow from control valve to the hydraulic cylinders. The route this oil takes will determine whether the dump will raise or lower.
- I. CONTROL LINKAGE** - Connects dump body control lever inside cab to the control valve.
- J. TRANSMISSION PTO CONTROL** - A manually-operated control lever located inside the vehicle cab that permits engagement or disengagement of the transmission PTO.
- K. TRANSMISSION PTO** - Uses driving power of the transmission to provide mechanical driving power for the hydraulic pump.

DUMP BODY HYDRAULIC SYSTEM OPERATION - Continued

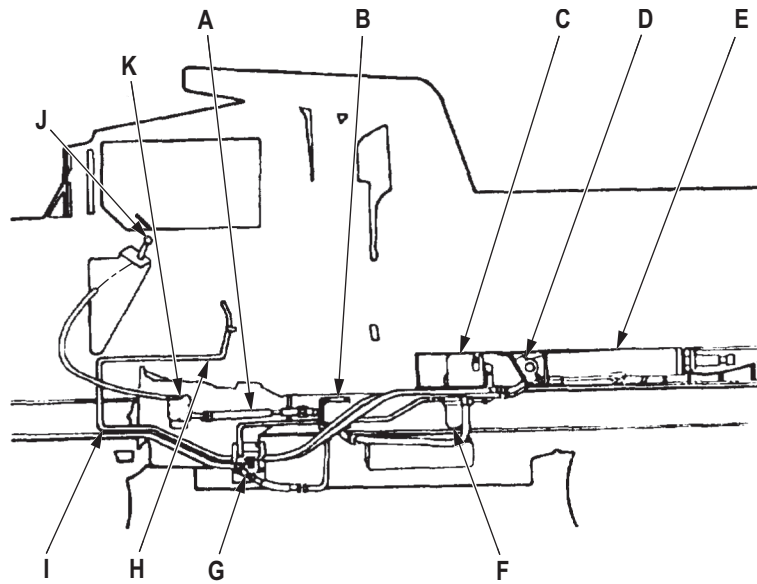

G0048DAA

Figure 36. Dump Body Hydraulic System Components.

MEDIUM WRECKER CRANE HYDRAULIC SYSTEM OPERATION

The M936/A1/A2 medium wrecker is equipped with a hydraulically-operated crane that extends a maximum 18 ft (5 m), elevates 45 degrees, and swings 360 degrees. It is capable of lifting loads up to 20,000 lbs (9,090 kg).

A. HYDRAULIC PUMP - Draws oil from hydraulic oil reservoir and directs it to valves inside the crane control console.

B. OIL FILTER - Filters used or bypassed oil from the control valve before it returns to the hydraulic oil reservoir.

C. HYDRAULIC OIL RESERVOIR - Storage tank for hydraulic oil.

D. SWIVEL VALVE - Permits oil to channel through pivot post while crane is swinging and eliminates twisting of the hydraulic lines connecting reservoir to the stationary pump.

E. BOOM LIFT CYLINDER - A hydraulically-driven piston that extends upward when boom control lever is pulled back to UP position, raising the boom. A check valve located near hydraulic oil inlet hose prevents piston from lowering when control lever is in NEUTRAL. Oil returns through boom control valve back to hydraulic oil reservoir allowing piston to lower when control lever is pushed forward to DOWN position.

F. BOOM CONTROL LEVER - Manual control attached to the control valve that determines hydraulic oil flow for raising and lowering action of the boom. Lever is pulled back to raise the boom and pushed forward to lower the boom.

G. CRANE CONTROL CONSOLE - Houses BOOM, HOIST, CROWD, and SWING levers and their control valves.

H. BOOM CONTROL VALVE - Located directly below boom control lever. Valve directs hydraulic oil from the hydraulic pump to the boom lift cylinder for lifting, or out of the lift cylinder and back to the hydraulic oil reservoir for lowering.

I. BOOM HYDRAULIC LINES - Carry the hydraulic oil to and from boom lift cylinder. Oil pumped through the bottom lines pushes the lift cylinder piston upward. Oil pumped through the top lines pushes the lift cylinder piston downward. When this downward action occurs, the oil that originally pushes the cylinder upwards is returned to the hydraulic oil reservoir.

J. TRANSFER CASE PTO CONTROL - A manually-operated control lever located inside the cab that engages and disengages the transfer case PTO.

K. TRANSFER CASE PTO LINKAGE - Connects transfer case PTO control to transfer case PTO.

L. TRANSFER CASE PTO - Receives driving power from vehicle's engine through the transfer case to provide mechanical driving power for the hydraulic pump.

M. PTO DRIVESHAFT - Transmits mechanical driving power from the power takeoff to the hydraulic pump.

MEDIUM WRECKER CRANE HYDRAULIC SYSTEM OPERATION - Continued

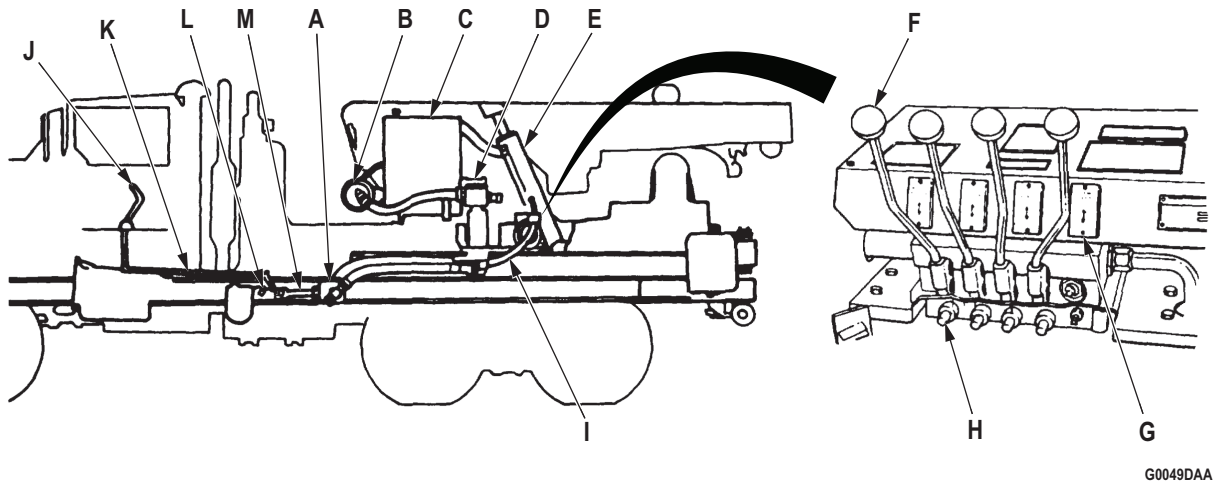

Figure 37. Medium Wrecker Crane Hydraulic System Components.

MEDIUM WRECKER CRANE HYDRAULIC SYSTEM OPERATION - Continued

A. HOIST MOTOR ASSEMBLY - Converts hydraulic power back into mechanical power needed to turn the hoist drum.

B. SHEAVES - Grooved wheels that guide hoist cable through boom.

C. UPPER ROLLER ASSEMBLY - Prevents cable from contacting inner boom during winding/unwinding.

D. CRANE HOIST CABLE DRUM - Is turned by the worm gear in hoist motor assembly. Drum unwinds cable when turning toward front of vehicle. Drum winds cable when turning towards rear of vehicle.

E. HOIST CONTROL LEVER - Manual control attached to the control valve that determines hydraulic oil flow for the raising and lowering action of the crane hoist cable and hook. Lever is pulled back to raise cable and hook and pushed forward to lower cable and hook.

F. HOIST CONTROL VALVE - Two-way hydraulic valve located under the hoist control lever directs fluid from the hydraulic pump to the hoist motor assembly and back through the valve to the hydraulic oil reservoir.

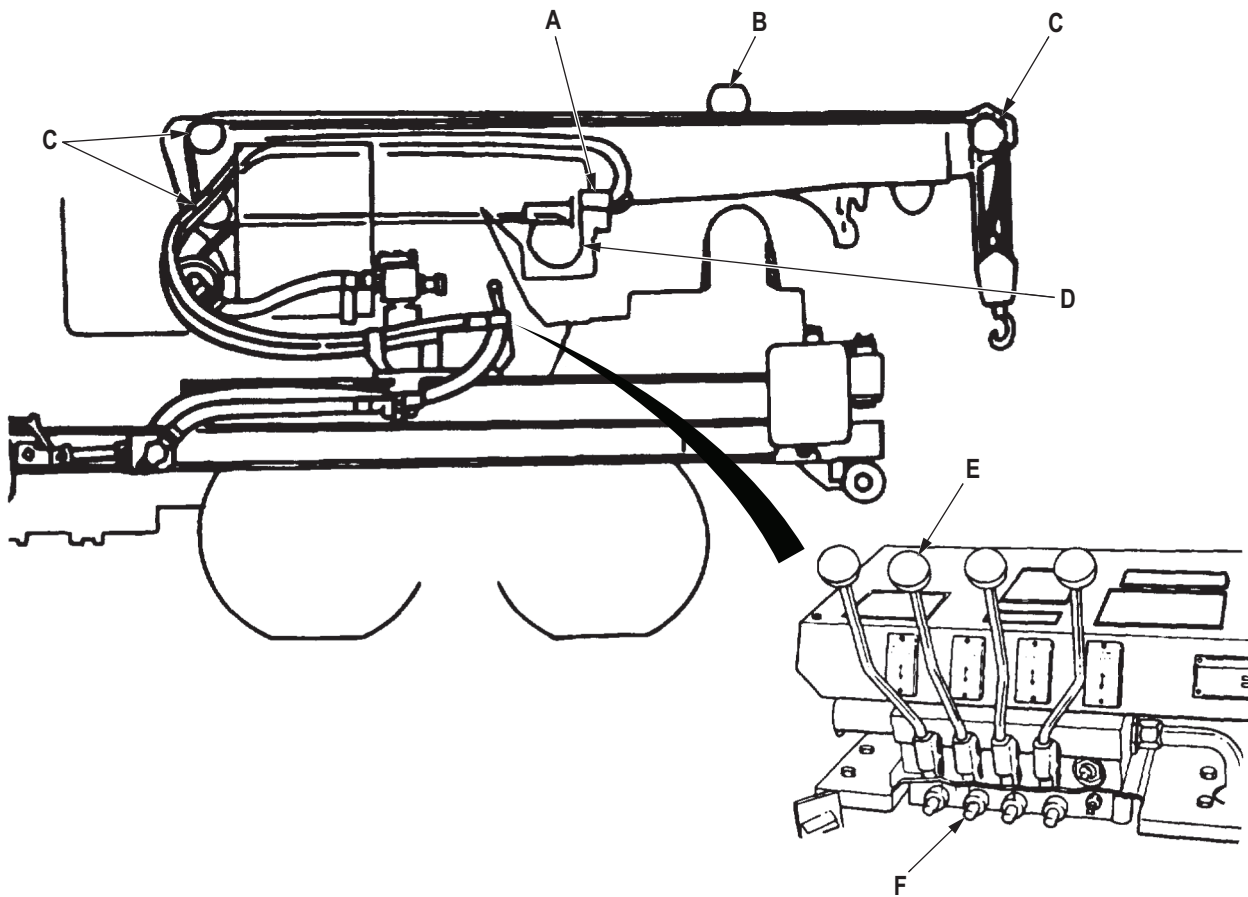

G0050DAA

Figure 38. Hoist Action Components.

MEDIUM WRECKER CRANE HYDRAULIC SYSTEM OPERATION - Continued

A. CROWD CONTROL LEVER - Manual control attached to the control valve that determines oil flow for extending and retracting the crane boom. Lever is pushed forward to extend the boom and pulled back to retract the boom.

B. ROLLERS - Guide inner boom assembly and permit smooth extension and retraction of boom.

C. INNER BOOM ASSEMBLY - Extends when crowd control lever is pushed forward and retracts when control lever is pulled back.

D. CROWD CYLINDER - A hydraulically-driven piston that extends outward when crowd control lever is pushed forward to EXTEND position. Piston is hydraulically-driven back into the cylinder when crowd control lever is pulled back to RETRACT position. This cylinder is contained in the inner boom assembly.

E. CROWD CONTROL VALVE - Two-way hydraulic valve located directly below crowd control lever. Valve directs hydraulic oil from the hydraulic pump to the crowd cylinder to extend and retract inner boom assembly.

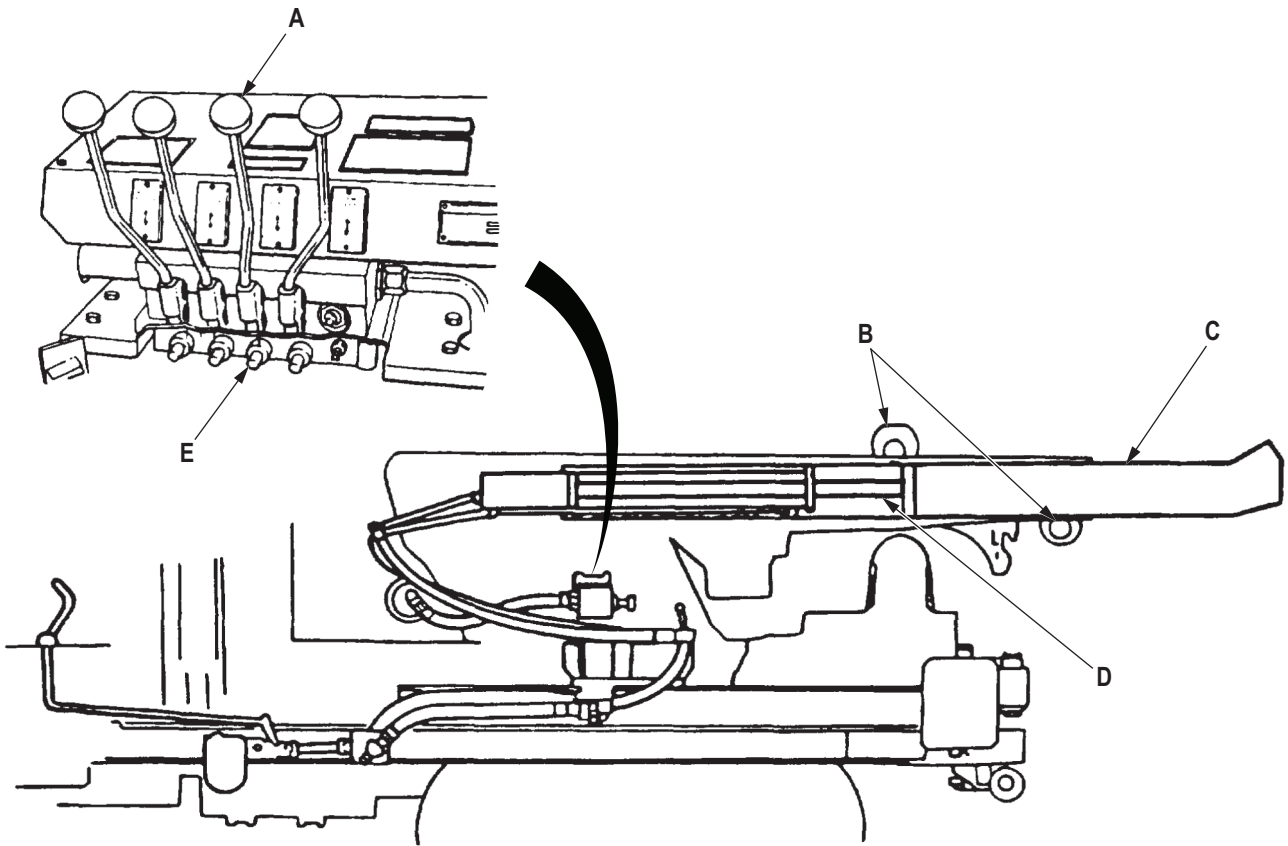

G0051DAA

Figure 39. Crowd Action Components.

MEDIUM WRECKER CRANE HYDRAULIC SYSTEM OPERATION - Continued

A. SWING MOTOR - Converts hydraulic power back into mechanical power needed to turn the crane turntable when hydraulic fluid is forced through its worm gear. This gear turns a large gear at the base of the turntable to swing the crane.

B. TURNTABLE ASSEMBLY - Driven by the swing motor through a ring gear at the base of the assembly, permits the crane to swing 360 degrees.

C. SWING CONTROL LEVER - Manual control attached to the control valve that determines hydraulic oil flow for swinging wrecker boom to the left and to the right. Lever is pushed inward for left boom movement, and pulled outward for right boom movement.

D. SWING CONTROL VALVE - Two-way hydraulic valve located directly below swing control lever. Valve directs hydraulic oil from the hydraulic pump to the swing motor assembly and back through the valve to the hydraulic oil reservoir.

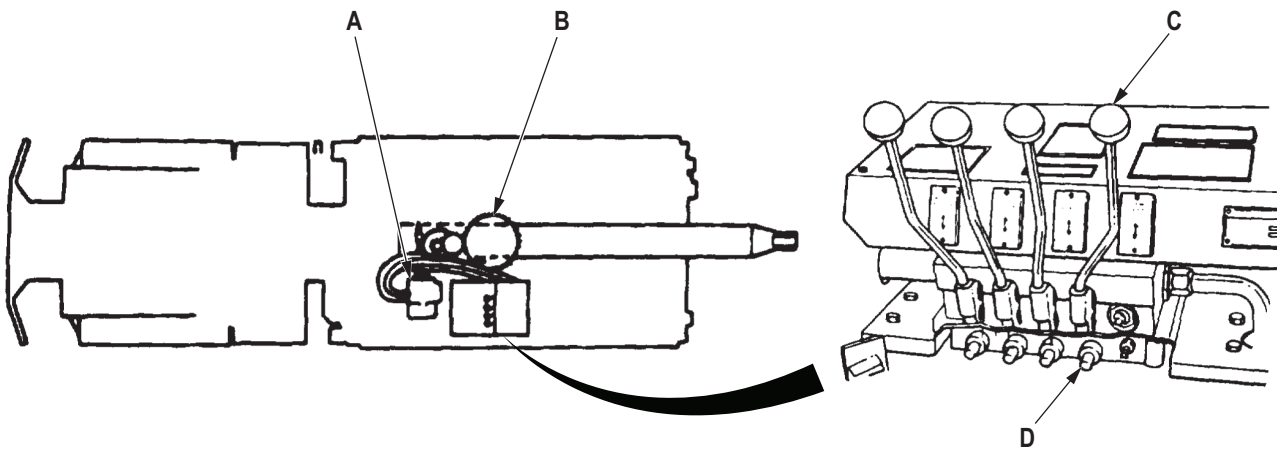

G0052DAA

Figure 40. Swing Action Components.

END OF WORK PACKAGE

CHAPTER 2

GENERAL TROUBLESHOOTING PROCEDURES

FIELD MAINTENANCE GENERAL TROUBLESHOOTING

INTRODUCTION

1. This chapter provides information needed to diagnose and correct malfunctions of mechanical, electrical, and compressed air and brake system at the field level of maintenance.
2. The troubleshooting procedures in this section cannot give all the answers or correct all vehicle malfunctions encountered. However, these procedures are a step-by-step approach to a problem that directs tests and inspections toward the source of a problem and a successful solution.
3. Principles of operation showing wiring diagrams for each system can be found in Theory of Operation (WP 0003). The wiring schematic (Volume 5, WP 0828) and point to point schematics show the interrelationship of these systems. Both should be utilized as references when performing troubleshooting procedures.
4. The compressed air schematic (Volume 5, WP 0828) and point to point schematics show the interrelationship of the compressed air and brake system. Both should be used as a reference when performing troubleshooting procedures.
5. Each malfunction symptom given for an individual component or system is followed by step(s) to determine the cause and corrective action you must take to remedy the problem.
6. Before taking any corrective action for a possible malfunction, the following rules should be followed:
 - a. Question operator to obtain any additional information that might help you to determine the cause of the problem.
 - b. Never overlook the chance the problem could be of a simple origin. The problem could require only a minor adjustment.
 - c. Use all senses to observe and locate troubles.
 - d. Use test instruments and gauges to help you determine and isolate problems.
 - e. Always isolate the system where the malfunction occurs and locate the defective component.
 - f. Use standard automotive theories and principles when troubleshooting the vehicles covered in this manual.
 - g. Operate the vehicle yourself to ensure the operator's description of the problem is correct.
7. This section cannot list all malfunctions that may occur. If a malfunction occurs that is not listed in the index, notify supervisor.
8. If malfunction corrective action does not correct malfunction, notify supervisor.

EXPLANATION OF TROUBLESHOOTING PROCEDURES

Troubleshooting procedures are defined as follows:

1. **STEP:** An action or process taken to isolate cause of fault.
2. **CONDITION/INDICATION:** States possible fault that may cause the symptom.
3. **DECISION:** Action required to move forward with next step or correct the fault.

END OF WORK PACKAGE

**FIELD MAINTENANCE
GENERAL TROUBLESHOOTING INDEX**

GENERAL TROUBLESHOOTING INDEX

Malfunction/Symptom

Troubleshooting Procedure

ENGINE

1. Engine Will Not Crank.....	WP 0006
2. Engine Cranks But Will Not Start.....	WP 0007
3. Starter Cranks Engine Slowly, Hard To Start.....	WP 0008
4. Engine Stops During Normal Operation.....	WP 0009
5. Engine Stops When Accelerator Is Returned To Idle Position.....	WP 0010
6. Engine Fails To Stop.....	WP 0011
7. Engine Runs, But Misfires.....	WP 0012
8. Engine Idle Rough Or Erratic.....	WP 0013
9. Poor Acceleration And/Or Lack Of Power.....	WP 0014
10. Engine Surges.....	WP 0015
11. Excessive Oil Consumption.....	WP 0016
12. Low Oil Pressure.....	WP 0017
13. Engine Oil Contaminated.....	WP 0018
14. Excessive Vibrating Or Clunking.....	WP 0019
15. Excessive Fuel Consumption.....	WP 0020
16. Engine Cranks But Will Not Start In Cold Weather (Fuel System Operating Properly).....	WP 0021
17. Exhaust Color Blue During Normal Operation.....	WP 0022
18. Exhaust Color White During Normal Operation.....	WP 0023
19. Exhaust Color Black During Normal Operation And Idle.....	WP 0024
20. Excessive Exhaust Noise.....	WP 0025
21. Exhaust Fumes In Cab.....	WP 0026
22. Engine Does Not Reach Normal Operating Temperature.....	WP 0027
23. Engine Overheats.....	WP 0028
24. Loss Of Coolant.....	WP 0029
25. Contaminated Coolant.....	WP 0030

TRANSMISSION

1. Excessive Noise During Shifting.....	WP 0031
---	---------

GENERAL TROUBLESHOOTING INDEX - Continued

<u>Malfunction/Symptom</u>	<u>Troubleshooting Procedure</u>
2. Low Transmission Oil Pressure.....	WP 0032
3. Transmission Oil Leaking.....	WP 0033
4. No Response To Shift Lever Movement.....	WP 0034
5. Rough Shifting.....	WP 0035
6. Transmission Overheats As Indicated By Transmission Temperature Gauge.....	WP 0036
7. Dirt Or Metal Particles In Transmission Oil.....	WP 0037
8. Oil Thrown From Transmission Dipstick Tube.....	WP 0038
9. Transmission Oil Dirty, Foamy, And/Or Milky.....	WP 0039

TRANSFER CASE

1. Hard Shifting Of Transfer Case.....	WP 0040
2. Transfer Case Leaking Oil.....	WP 0041
3. Excessive Noise.....	WP 0042
4. Excessive Vibration.....	WP 0043

DRIVELINE

1. Excessive Propeller And Driveshaft Noise Or Vibration.....	WP 0044
2. Continuous Axle Or Wheel Noise.....	WP 0045

FRAME AND CHASSIS

1. Towing Pintle Does Not Latch or lock.....	WP 0046
2. Pintle Hook Does Not Turn.....	WP 0047
3. Excessively Loose Lifting Shackle.....	WP 0048
4. Loose Spare Tire Carrier.....	WP 0049

STEERING/TIRE

1. Uneven Tire Wear.....	WP 0050
2. Wheel Shimmy Or Wobble.....	WP 0051
3. Hard Steering.....	WP 0052
4. Vehicle Wanders Or Pulls To One Side.....	WP 0053
5. Excessive Play In Steering Wheel.....	WP 0054
6. Shimmy.....	WP 0055
7. Continuous Wandering Or Swaying (Poor Control).....	WP 0056

GENERAL TROUBLESHOOTING INDEX - Continued

Malfunction/Symptom

Troubleshooting Procedure

- 8. Harsh Or Hard Ride..... WP 0057
- 9. Spring Leaf Defect..... WP 0058

WINCH

- 1. Winch Does Not Operate..... WP 0059
- 2. Winch Operates In One Direction Only..... WP 0060
- 3. Drag Brake Does Not Operate..... WP 0061
- 4. Winch Will Not Hold Load..... WP 0062
- 5. Automatic Brake Overheats..... WP 0063
- 6. Front Winch Operates At One Speed Only..... WP 0064
- 7. Rear Winch Cable Tensioner Will Not Operate..... WP 0065
- 8. Vehicle Rolls While Operating Rear Inch..... WP 0066

PTO

- 1. PTO Excessively Noisy..... WP 0067
- 2. PTO Shifts Hard..... WP 0068
- 3. PTO Leaking Lubricant..... WP 0069

RADIO INTERFERENCE

- 1. Radio Interference..... WP 0070

FIFTH WHEEL

- 1. Trailer Will Not Hitch To Fifth Wheel..... WP 0071

WRECKER

- 1. Wrecker Hydraulic System Does Not Operate..... WP 0072
- 2. Wrecker Hydraulic Pump Noisy..... WP 0073

DUMP BODY

- 1. Dump Body Will Not Raise..... WP 0074
- 2. Dump Body Will Not Lower..... WP 0075
- 3. Dump Body Will Not Hold In Raised Position..... WP 0076
- 4. Dump Hydraulic Pump Noisy..... WP 0077
- 5. Dump Tailgate Will Not Open..... WP 0078

GENERAL TROUBLESHOOTING INDEX - Continued

Malfunction/Symptom

Troubleshooting Procedure

EXPANSIBLE VAN

- 1. Side Panels Hard To Retract Or Expand..... WP 0079
- 2. Side Panel Cannot Be Locked In Retracted Position..... WP 0080
- 3. Van Body Not Waterproof Or Light Tight..... WP 0081
- 4. Door Lock Will Not Operate..... WP 0082

ENGINE AND VEHICLE ELECTRICAL SYSTEM

- 1. Engine And Vehicle Electrical System Malfunctioning..... WP 0083
- 2. Engine Will Not Crank; Some Electrical Systems Inoperative Or Weak..... WP 0084
- 3. All Vehicle Electrical Systems Inoperative..... WP 0085
- 4. Starter Motor Inoperative..... WP 0086
- 5. Solenoid Operates, Starter Operates, But Engine Cranks Slowly..... WP 0087
- 6. Starter Motor Inoperative; No Solenoid Thump..... WP 0088
- 7. No Or Low Alternator Output..... WP 0089
- 8. No Alternator Output (100 Amp Alternator)..... WP 0090
- 9. Alternator Overcharging, Battery Indicator Gauge In Red Position..... WP 0091
- 10. Headlamp (One Side) Inoperative..... WP 0092
- 11. Headlamp (Both Sides) Inoperative..... WP 0093
- 12. Blackout Drive Or Blackout Marker Light Inoperative..... WP 0094
- 13. Stoplight Inoperative (Service Or Blackout)..... WP 0095
- 14. Tail Or Marker Lights Inoperative..... WP 0096
- 15. Individual Lights Do Not Light With Directional Signal Lever In Any Position..... WP 0097
- 16. No Lights Operate With Directional Signal Control Lever In Any Position..... WP 0098
- 17. System Operates Incorrectly In One Or More Positions Of Directional Signal Control Lever..... WP 0099
- 18. Protective Control Box Assembly Test..... WP 0100

INDICATOR, GAUGE, AND WARNING SYSTEM

- 1. Speedometer Or Tachometer Noisy Or Erratic..... WP 0101
- 2. Air Pressure Gauge Inoperative..... WP 0102
- 3. Oil Pressure Gauge Inoperative (Oil Level Is Correct)..... WP 0103

GENERAL TROUBLESHOOTING INDEX - Continued

<u>Malfunction/Symptom</u>	<u>Troubleshooting Procedure</u>
4. All Gauges Inoperative.....	WP 0104
5. Transmission Temperature Gauge Inoperative.....	WP 0105
6. Temperature Gauge Inoperative (Coolant).....	WP 0106
7. Fuel Gauge Inoperative.....	WP 0107
8. Battery/Alternator Gauge Inoperative.....	WP 0108
9. Horn Inoperative.....	WP 0109
10. Low Air Pressure Warning Buzzer Will Not Shut Off (Air Pressure Gauges At Normal System Pressure).....	WP 0110
11. Low Air Pressure Warning Buzzer Will Not Shut Off And Parking Brake Warning Light Flashes With Hand/Parking Brake In Any Position (Air Pressure Normal).....	WP 0111
12. Spring Brake Warning Light Inoperative With Spring Brake Override Engaged.....	WP 0112
 TRAILER CONNECTION	
1. One Or More Trailer Lights Inoperative.....	WP 0113
 CAB HEATER	
1. Heater Will Not Operate With Switch In LOW Position (HIGH Position Operation Normal).....	WP 0114
2. Heater will Not Operate With Switch In HIGH position (LOW Position Operation Normal).....	WP 0115
3. Heater Will Not Operate In LOW Or HIGH Position.....	WP 0116
4. No Cab Heat (Coolant Temperature Gauge Reads Normal).....	WP 0117
 COMPRESSED AIR AND BRAKE SYSTEM	
1. Parking Brake Does Not Hold Vehicle On Grade.....	WP 0118
2. Parking Brake Drags, As Indicated By Smoking Or Burning Smell.....	WP 0119
3. Insufficient Brakes (Vehicle Stopping Distance Too Long, No Apparent Air System Failure With Gauges At Normal Operating Pressure, Warning Buzzer Not Sounding).....	WP 0120
4. Vehicle Pulls Right Or Left When Applying Brakes.....	WP 0121
5. Vehicle Rear Brakes Grab Or Drag.....	WP 0122
6. Vehicle Vibrates, Chatters, Or Bounces When Brakes Are Applied.....	WP 0123
7. Brakes Squeal.....	WP 0124

GENERAL TROUBLESHOOTING INDEX - Continued

<u>Malfunction/Symptom</u>	<u>Troubleshooting Procedure</u>
8. Warning Buzzer Sounds When Brakes Are Applied (Primary And Secondary Gauge Pressure Drops Below 55-65 psi (379-448 kPa)).....	WP 0125
9. No Air Pressure (Warning Buzzer Sounding, Air Pressure Not Building To Normal Operating Range As Indicated By Gauges).....	WP 0126
10. Air Pressure Does Not Build To Normal Operating Pressure (Above 80 psi (552 kPa)) According To Gauges.....	WP 0127
11. Air Pressure Builds Slowly (Takes Excessive Amount Of Time To Build To 100 psi (690kPa)).....	WP 0128
12. Air Pressure Exceeds Maximum (Gauges Show Over 130 psi (896 kPa)), Safety Valve Opens To Release Pressure.....	WP 0129
13. Primary Pressure Gauge Reads No Pressure, Low Pressure, Or Builds To Normal Operating Pressure Slowly. Secondary Pressure Gauge Reads Normal (Engine Idling, Brake Pedal Not Applied).....	WP 0130
14. Secondary Pressure Gauge Reads No Pressure, Low Pressure, Or Builds To Normal Operating Pressure Slowly. Primary Pressure Gauge Reads Normal (Engine Idling, Brake Pedal Not Applied).....	WP 0131
15. Primary Air System Fails To Maintain Pressure (No Major Leaks, Air Can Be Heard Escaping Into Air Intake Stack, Parking Brake Applied).....	WP 0132
16. Secondary Air System Fails To Maintain Pressure (No Major Leaks, Air Can Be Heard Escaping Into Air Intake Stack, Parking Brake Applied).....	WP 0133
17. Warning Buzzer Fails To Sound Or Fails To Shut Off On Low Pressure (below 55-65 psi (379-448 kPa)), Air Pressure System Operating Normally.....	WP 0134
18. Spring Brakes Do Not Release (Vehicle Brakes Grab Or Drag).....	WP 0135
19. Spring Brakes Do Not Set (Gauges At Normal Operating Pressures, Air Exhausting Not Heard When Parking Brake Applied).....	WP 0136
20. All Air-Operated Accessories Do Not Operate (Horn, Windshield Wipers, Windshield Washers, Transfer Case Controls), Gauges At Normal Operating Pressure.....	WP 0137
21. Cooling Fan Does Not Operate, Engine Temperature Above 200°F (93°C) As Indicated By Temperature Gauge.....	WP 0138
22. Cooling Fan Does Not Stop Running, Engine Temperature Below Normal Operating Range (Override Bolt Not Installed).....	WP 0139
23. Front Wheel Drive Does Not Engage (Front Wheel Drive Lock-In Switch Engaged And Transfer Case Shift Lever In HIGH Position).....	WP 0140

GENERAL TROUBLESHOOTING INDEX - Continued

Malfunction/Symptom

Troubleshooting Procedure

24. Horn Does Not Work (Gauges At Normal Operating Pressure,
Warning Buzzer Not Sounding)..... WP 0141

END OF WORK PACKAGE

**FIELD MAINTENANCE
ENGINE FAILS TO CRANK**

INITIAL SETUP:**Tools and Special Tools**

Tool Kit, General Mechanic's: Automotive
(Volume 5, WP 0826, Table 1, Item 56)
Multimeter
(Volume 5, WP 0826, Table 1, Item 34)
Test Set, Electronic Systems
(Volume 5, WP 0826, Table 1, Item 51)

References (cont.)

WP 0086
WP 0088
Volume 2, WP 0220
Volume 2, WP 0303
Volume 2, WP 0346
Volume 2, WP 0349
Volume 2, WP 0350

Personnel Required

(2)

Equipment Condition

Vehicle parked and engine shut down.
(TM 9-2320-272-10)

References

Point to Point Schematics

TROUBLESHOOTING PROCEDURE**ENGINE FAILS TO CRANK****NOTE**

Conduct these malfunction tests if engine fails to crank. This procedure will check battery cables, clamps, posts and cases, starter motor, flywheel ring gear, specific gravity levels for each battery, test battery voltage and check for a seized engine.

ENGINE FAILS TO CRANK - Continued**STEP**

1. ARE ALL THE BATTERY CABLES, CLAMPS, POSTS, AND CASES FREE OF CORROSION, DAMAGE, LOOSENESS AND CRACKS?
 - a. Visually inspect battery cables, clamps, and posts for breaks, looseness, corrosion, and damage.

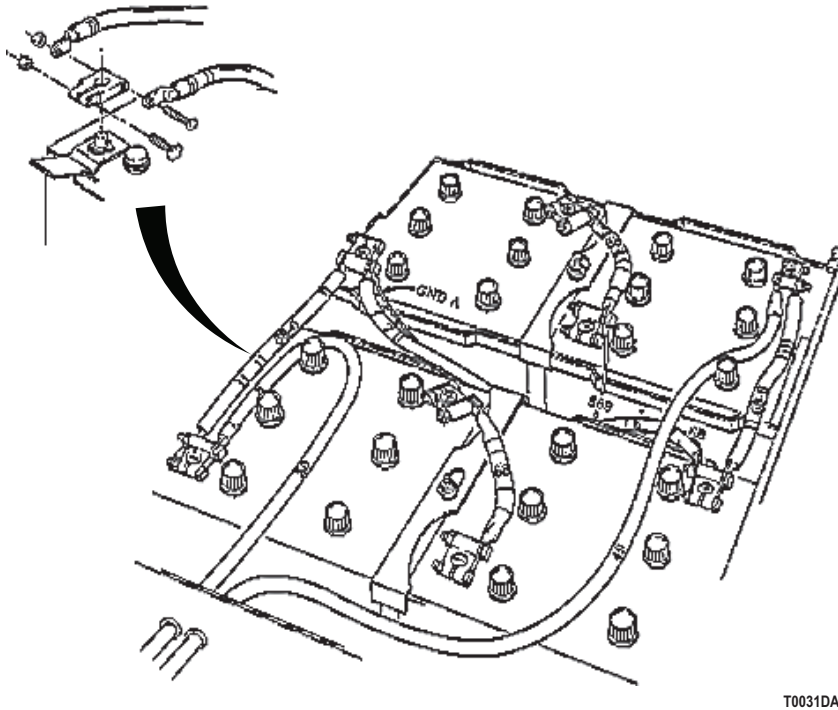

Figure 1. Battery Cables.

- b. Inspect battery cases for cracks.

CONDITION/INDICATION

ARE ALL THE BATTERY CABLES, CLAMPS, POSTS, AND CASES FREE OF CORROSION, DAMAGE, LOOSENESS AND CRACKS?

DECISION

NO - Cable or clamp corroded or loose. Repair or replace corroded or damaged cable or clamp (Volume 2, WP 0349). Go to Step (9) to verify problem is solved.

NO - Cable clamp loose. Tighten loose battery cable clamp (Volume 2, WP 0349). Go to Step (9) to verify problem is solved.

NO - Battery case cracked or post damaged. Replace cracked battery case or damaged post (Volume 2, WP 0346). Go to Step (9) to verify problem is solved.

YES - Go to Step (2).

ENGINE FAILS TO CRANK - Continued**STEP**

2. DO BATTERIES HAVE CORRECT SPECIFIC GRAVITY?
 - a. Access batteries.

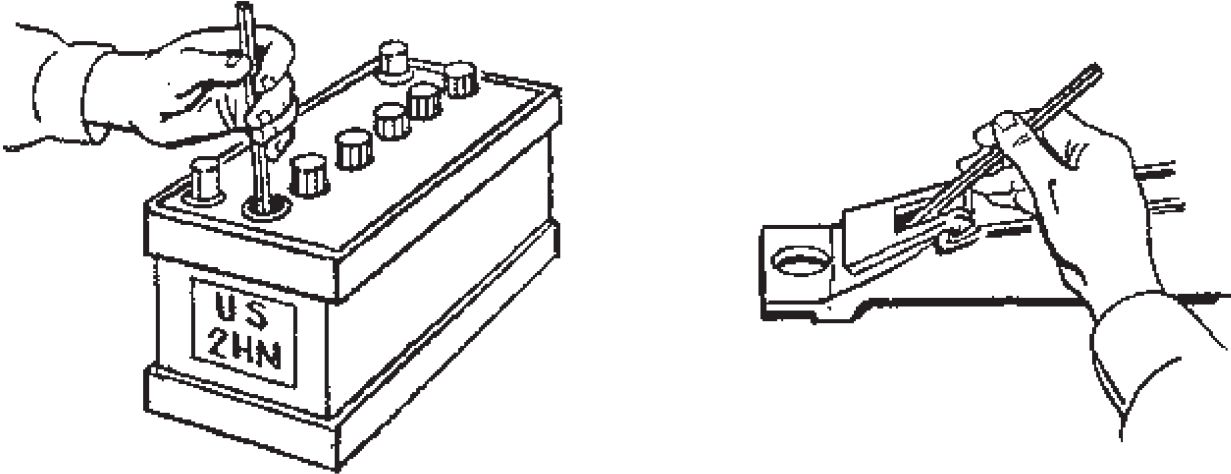

T0033DAA

Figure 2. Battery Specific Gravity Test.

- b. Check each battery for specific gravity. Correct level is 1.225 or greater, temperature corrected. Each cell must also test within 25 points of the others.
- c. If specific gravity is incorrect add distilled water or recharge batteries if necessary.
- d. Perform specific gravity test again.

CONDITION/INDICATION

DO BATTERIES HAVE CORRECT SPECIFIC GRAVITY?

DECISION

NO - Replace defective battery (Volume 2, WP 0346). Go to Step (9) to verify problem is solved.
 YES - Go to Step (3).

ENGINE FAILS TO CRANK - Continued**STEP**

3. IS BATTERY TO STARTER OR BATTERY TO FRAME CABLE, LOOSE, CORRODED, OR DAMAGED?
 - a. Visually inspect starter and ground cables for looseness.

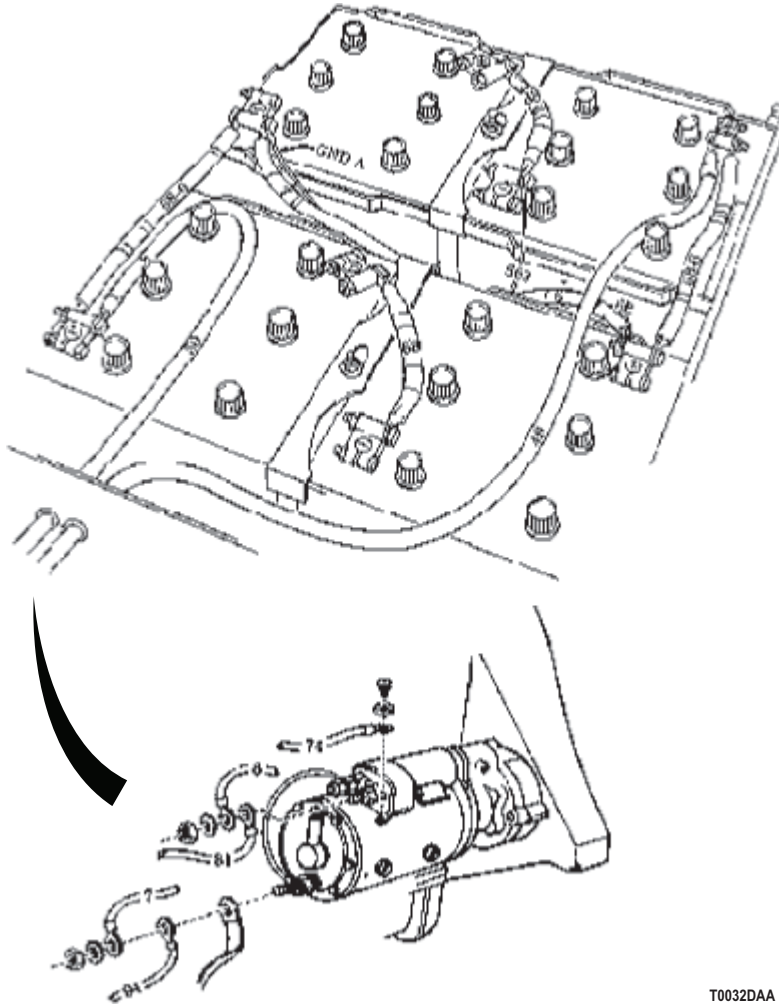

T0032DAA

Figure 3. Starter Cables.

- b. Visually inspect starter and ground cables for corrosion and damage.

CONDITION/INDICATION

IS BATTERY TO STARTER OR BATTERY TO FRAME CABLE, LOOSE, CORRODED, OR DAMAGED?

DECISION

YES - Battery to starter cable faulty. Repair or replace faulty battery to starter cable (Volume 2, WP 0349). Go to Step (9) to verify problem is solved.

YES - Battery ground cable faulty. Repair or replace faulty battery ground cable (Volume 2, WP 0350). Go to Step (9) to verify problem is solved.

NO - Go to Step (4).

ENGINE FAILS TO CRANK - Continued**STEP**

4. DO BATTERIES HAVE PROPER VOLTAGE?
 - a. Set multimeter to measure voltage.

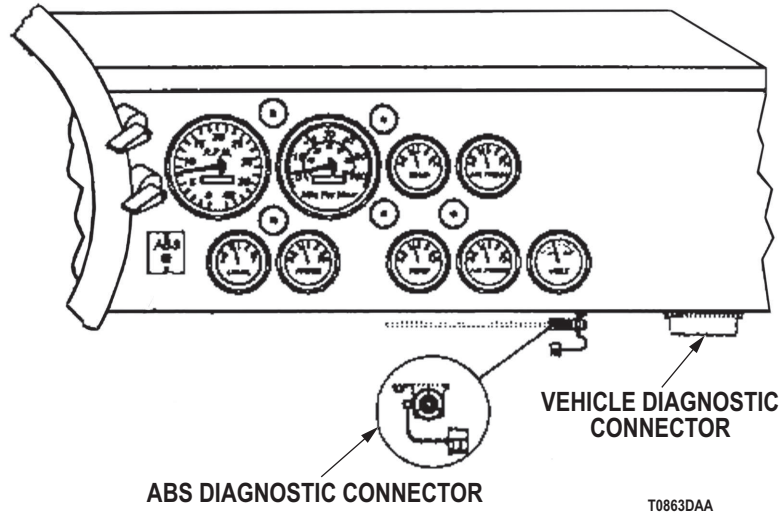

Figure 4. DCA Connection.

- b. Connect multimeter red lead to DCA connector, terminal V. Refer to point to point schematics.
- c. Connect multimeter black lead to DCA connector, terminal W.
- d. Meter should display a reading between 23.5 and 25.5 VDC.

CONDITION/INDICATION

DO BATTERIES HAVE PROPER VOLTAGE?

DECISION

NO - Replace defective batteries (Volume 2, WP 0346). Go to Step (9) to verify problem is solved.
 YES - Go to Step (5).

ENGINE FAILS TO CRANK - Continued**STEP**

5. DOES THE STARTER MOTOR SOLENOID SOUND LIKE IT IS ENERGIZED?
- a. Set vehicle controls to crank engine.

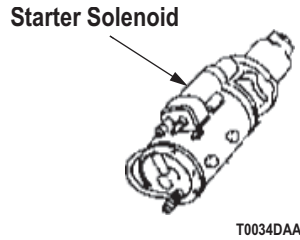

Figure 5. Starter Solenoid.

- b. Depress starter switch and listen to starter motor solenoid inside engine compartment.

CONDITION/INDICATION

DOES THE STARTER MOTOR SOLENOID SOUND LIKE IT IS ENERGIZED?

DECISION

NO - Perform Starter Motor Inoperative, No Solenoid Thump troubleshooting (WP 0088).
YES - Go to Step (7).

STEP

6. DOES THE STARTER MOTOR SOUND LIKE IT IS RUNNING OVERSPEED?
- a. Set vehicle controls to crank engine.

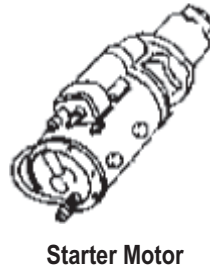

Figure 6. Starter Motor.

- b. Depress starter switch and listen to starter motor.

ENGINE FAILS TO CRANK - Continued**CONDITION/INDICATION**

DOES THE STARTER MOTOR SOUND LIKE IT IS RUNNING OVERSPEED?

DECISION

NO - Perform Starter Motor Inoperative troubleshooting (WP 0086).

YES - Go to Step (7).

STEP

7. DOES THE STARTER DRIVE OR RING GEAR HAVE ANY BROKEN OR MISSING TEETH?
 - a. Remove starter motor (Volume 2, WP 0303).

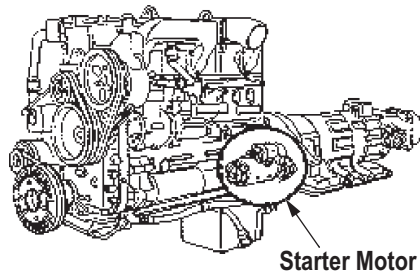

T0036DAA

Figure 7. Starter Motor.

- b. Check starter drive and ring gear for missing and/or damaged teeth.

CONDITION/INDICATION

DOES THE STARTER DRIVE OR RING GEAR HAVE ANY BROKEN OR MISSING TEETH?

DECISION

YES - Starter damaged. Replace damaged starter motor (Volume 2, WP 0303). Go to Step (9) to verify problem is solved.

YES - Ring gear damaged. Replace damaged ring gear (Volume 2, WP 0220). Go to Step (9) to verify problem is solved.

NO - Go to Step (8).

ENGINE FAILS TO CRANK - Continued**STEP**

8. IS ENGINE SEIZED?
 - a. Starter motor remove.
 - b. Rotate engine at vibration damper bolt two full revolutions.

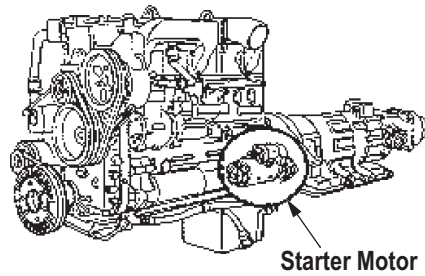

T0036DAA

*Figure 8. Starter Motor.***CONDITION/INDICATION**

IS ENGINE SEIZED?

DECISION

NO - Replace starter motor (Volume 2, WP 0303). Go to Step (9) to verify problem is solved.
 YES - Notify supervisor that engine is seized. Action may not be possible at this level of maintenance.

STEP

9. IS YOUR ORIGINAL ENGINE CRANK PROBLEM STILL PRESENT?
 - a. Ensure vehicle is returned to normal operating condition.
 - b. Check to see if your original engine crank problem still exists.

CONDITION/INDICATION

IS YOUR ORIGINAL ENGINE CRANK PROBLEM STILL PRESENT?

DECISION

YES - Notify supervisor.
 NO - Problem fixed.

END OF WORK PACKAGE

**FIELD MAINTENANCE
ENGINE CRANKS BUT DOES NOT START**

INITIAL SETUP:**Tools and Special Tools**

Tool Kit, General Mechanic's: Automotive
(Volume 5, WP 0826, Table 1, Item 56)
Test Set, Electronic Systems
(Volume 5, WP 0826, Table 1, Item 51)

Personnel Required

(2)

References

Point to Point Schematics
TM 9-2320-272-10
WP 0021
WP 0086
Volume 2, WP 0239
Volume 2, WP 0241

References (cont.)

Volume 2, WP 0243
Volume 2, WP 0251
Volume 2, WP 0254
Volume 2, WP 0258
Volume 2, WP 0259
Volume 2, WP 0260
Volume 2, WP 0263
Volume 2, WP 0264
Volume 2, WP 0265
Volume 2, WP 0266

Equipment Condition

Vehicle parked and engine shut down.
(TM 9-2320-272-10)

TROUBLESHOOTING PROCEDURE**ENGINE CRANKS BUT DOES NOT START****NOTE**

Conduct these malfunction tests if engine fails to start. This procedure will check for the emergency engine stop control not correctly set, air in fuel system, coolant in combustion chambers, loose fuel supply line connections or fuel supply line at fuel filter head, leaking or damaged primary fuel filter, contaminated fuel, low fuel supply or vacuum pressure, and an empty ether cylinder. It also checks for a faulty fuel transfer pump, fuel supply line, starter circuit, fuel filter, ether start system, thermal close valve, and ether atomizer. In addition, this procedure checks for a clogged or dirty air intake stack, air cleaner element, fuel injector supply line, fuel filter, fuel pump filter, thermal close valve tubing, and atomizer tubing.

ENGINE CRANKS BUT DOES NOT START - Continued

STEP

1. DOES ENGINE START WITH EMERGENCY ENGINE STOP CONTROL ALL THE WAY IN?
 - a. Verify emergency engine stop control is all the way in and emergency shutoff valve has been reset (TM 9-2320-272-10).

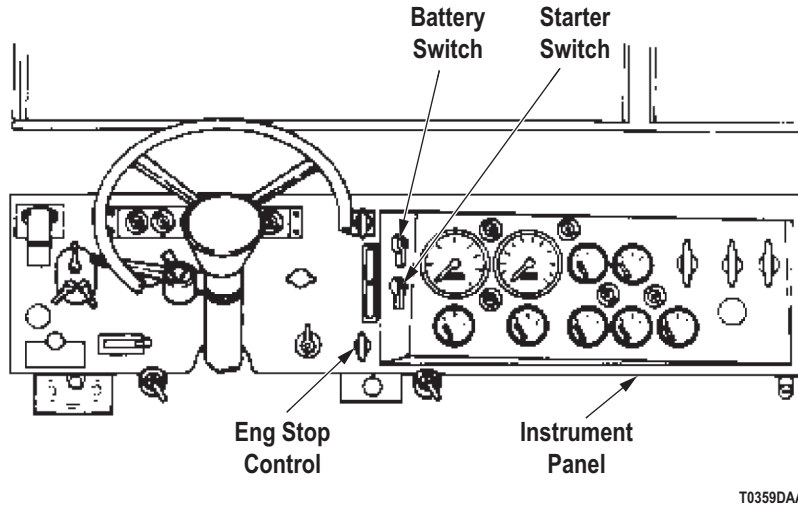

Figure 1. Engine Stop Control.

- b. Press accelerator pedal all the way down to floor and hold while trying to start engine.

CONDITION/INDICATION

DOES ENGINE START WITH EMERGENCY ENGINE STOP CONTROL ALL THE WAY IN?

DECISION

- YES - Problem fixed.
- NO - Go to Step (2).

STEP

2. IS AIR CLEANER INDICATOR IN RED ZONE?
 - a. Check air cleaner indicator for air restriction indication.

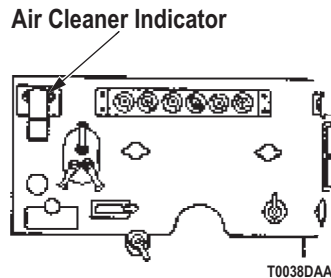

Figure 2. Air Cleaner Indicator.

ENGINE CRANKS BUT DOES NOT START - Continued

- b. Inspect air intake stack for restrictions.

CONDITION/INDICATION

IS AIR CLEANER INDICATOR IN RED ZONE?

DECISION

YES - Perform air cleaner servicing (TM 9-2320-272-10). Go to Step (22) to verify problem is solved.
NO - Go to Step (3).

STEP

3. IS THERE WHITE SMOKE DURING CRANKING?

Try to start engine while checking for white smoke in exhaust.

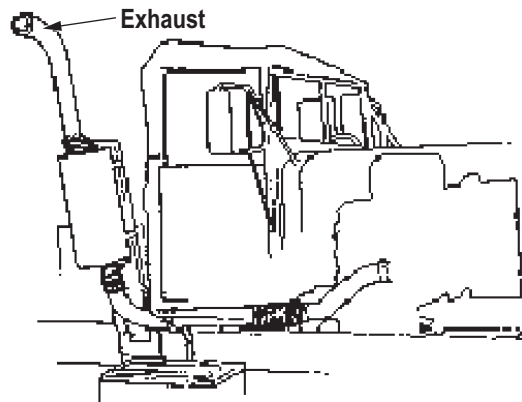

T0360DAA

Figure 3. Engine Exhaust.

CONDITION/INDICATION

IS THERE WHITE SMOKE DURING CRANKING?

DECISION

NO - Go to Step (6).
YES - Go to Step (4).

ENGINE CRANKS BUT DOES NOT START - Continued**STEP****4. DOES ENGINE START AFTER PRIMING FUEL SYSTEM?****WARNING**

Diesel fuel is highly flammable. Do not perform fuel system procedures near open flame. Failure to comply may result in injury or death to personnel.

- a. Prime the fuel system M939/A1 (TM 9-2320-272-10), M939A2 (Volume 2, WP 0239).

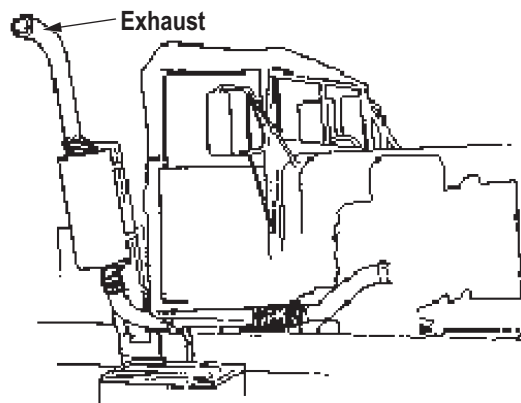

T0360DAA

Figure 4. Engine Exhaust.

NOTE

If engine starts, there was air in fuel system.

- b. Try to start engine while checking for white smoke in exhaust.

CONDITION/INDICATION

DOES ENGINE START AFTER PRIMING FUEL SYSTEM?

DECISION

YES - Problem fixed.
NO - Go to Step (5).

ENGINE CRANKS BUT DOES NOT START - Continued**STEP****5. IS THERE COOLANT IN THE COMBUSTION CHAMBERS?**

Remove the dipstick and look for evidence of coolant on the dipstick.

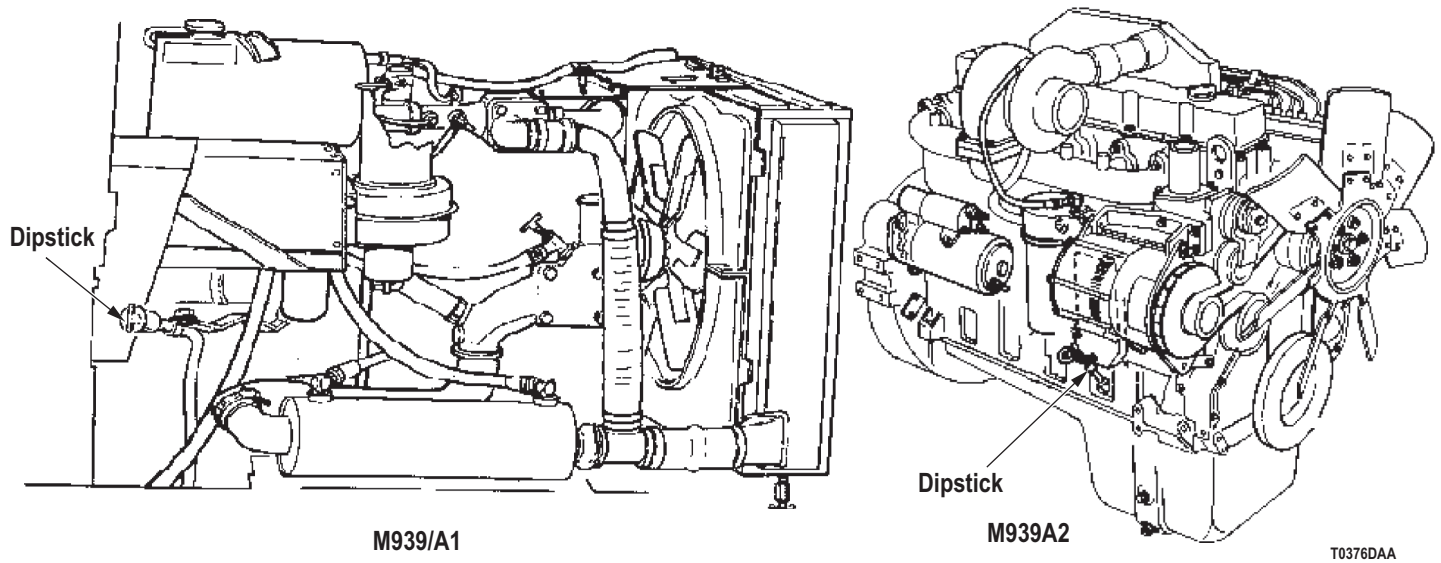

Figure 5. Engine Dipstick.

CONDITION/INDICATION

IS THERE COOLANT IN THE COMBUSTION CHAMBERS?

DECISION

NO - Notify supervisor. It is possible that another troubleshooting work package applies.

YES - Notify supervisor that there is coolant in the combustion chambers. Action may not be possible at this level of maintenance.

ENGINE CRANKS BUT DOES NOT START - Continued**STEP****6. IS THE FUEL SUPPLY LINE LOOSE AT FUEL FILTER HEAD?**

Check for loose fuel supply line at fuel filter head.

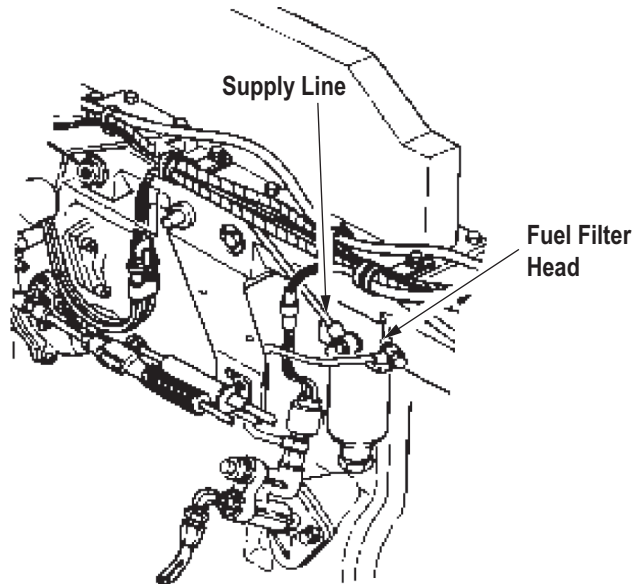

T0361DAA

Figure 6. Engine Fuel Supply Line.

CONDITION/INDICATION

IS THE FUEL SUPPLY LINE LOOSE AT FUEL FILTER HEAD?

DECISION

NO - Go to Step (11) (M939/A1 vehicles).

NO - Go to Step (7) (M939A2 vehicles).

YES - Tighten fuel supply line (Volume 2, WP 0243). Go to Step (22) to verify problem is solved.

ENGINE CRANKS BUT DOES NOT START - Continued**STEP****7. IS FUEL TRANSFER PUMP OPERATING PROPERLY?**

- a. Loosen plunger on fuel transfer pump until air is purged from fuel system.

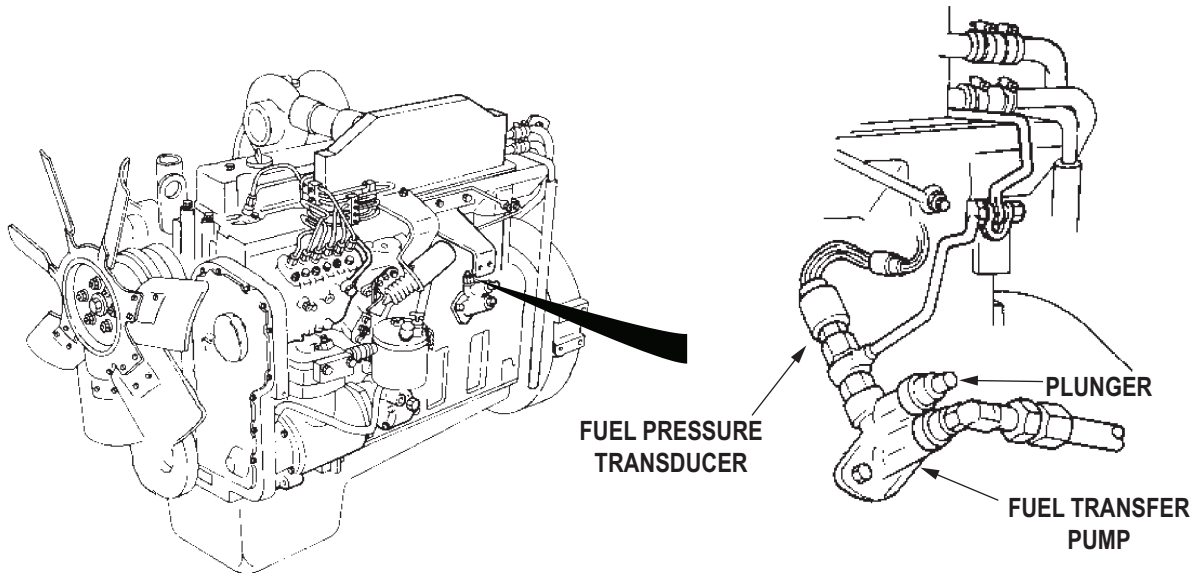

T0362DAA

Figure 7. Fuel Transfer Pump.

NOTE

If fuel is present at fuel transfer pump when operating hand primer, fuel transfer pump is not operating properly.

- b. Check for fuel at fuel transfer pump while operating hand primer.

CONDITION/INDICATION

IS FUEL TRANSFER PUMP OPERATING PROPERLY?

DECISION

YES - Go to Step (8).

NO - Replace fuel transfer pump (Volume 2, WP 0243). Go to Step (22) to verify problem is solved.

ENGINE CRANKS BUT DOES NOT START - Continued**STEP****8. IS FUEL LEAKING FROM FUEL PRESSURE TRANSDUCER?**

Check for fuel leaking from fuel pressure transducer.

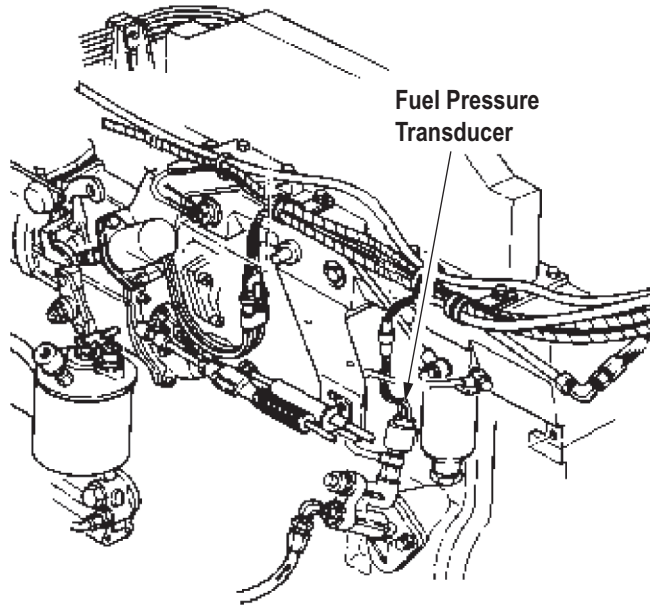

T0364DAA

Figure 8. Fuel Pressure Transducer.

CONDITION/INDICATION

IS FUEL LEAKING FROM FUEL PRESSURE TRANSDUCER?

DECISION

NO - Go to Step (11).
 YES - Go to Step (9).

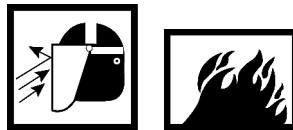
STEP**9. IS THE FUEL INJECTOR SUPPLY LINE CLOGGED?****WARNING**

- Eyeshields must be worn when cleaning with compressed air. Compressed air source will not exceed 30 psi (207 kPa). Failure to comply may result in injury or death to personnel.
- Diesel fuel is highly flammable. Do not perform fuel system procedures near open flame. Failure to comply may result in injury or death to personnel.

ENGINE CRANKS BUT DOES NOT START - Continued

Disconnect fuel injector supply lines and check for clogs (Volume 2, WP 0241).

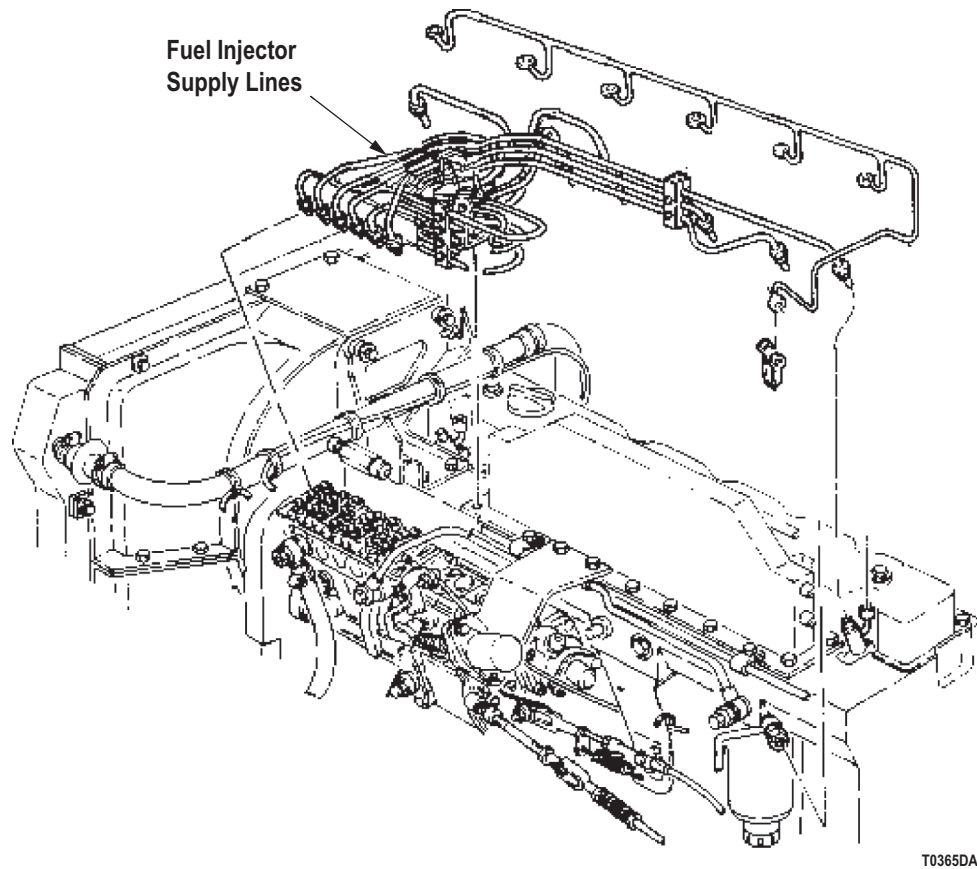

Figure 9. Fuel Injector Supply Lines.

CONDITION/INDICATION

IS THE FUEL INJECTOR SUPPLY LINE CLOGGED?

DECISION

YES - Clear all clogged fuel injector supply lines with compressed air or sturdy wire (Volume 2, WP 0241). Go to Step (22) to verify problem is solved.

NO - Go to Step (10).

ENGINE CRANKS BUT DOES NOT START - Continued**STEP****10. IS THE FUEL FILTER DIRTY OR CLOGGED?**

Remove fuel filter and check for a dirty filter or clogs (Volume 2, WP 0258).

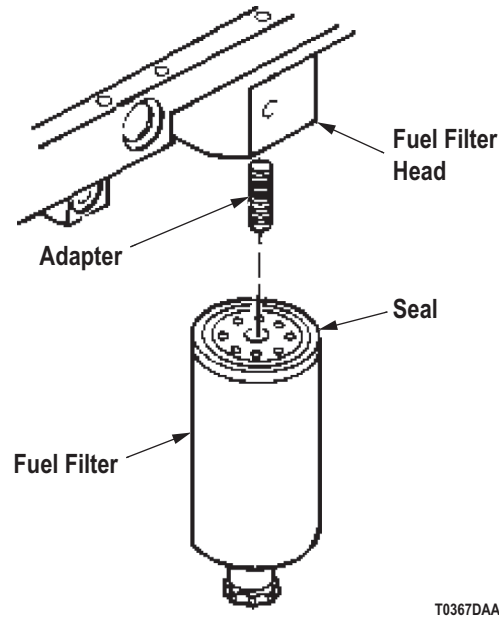

T0367DAA

Figure 10. Fuel Filter.

CONDITION/INDICATION

IS THE FUEL FILTER DIRTY OR CLOGGED?

DECISION

YES - Replace fuel filter (Volume 2, WP 0258). Go to Step (22) to verify problem is solved.
 NO - Notify supervisor. It is possible that another troubleshooting work package applies.

STEP**11. IS FUEL SYSTEM IN GOOD OPERATING CONDITION?****WARNING**

Diesel fuel is highly flammable. Do not perform fuel system procedures near open flame. Failure to comply may result in injury or death to personnel.

- a. Verify that there is fuel in the tank.

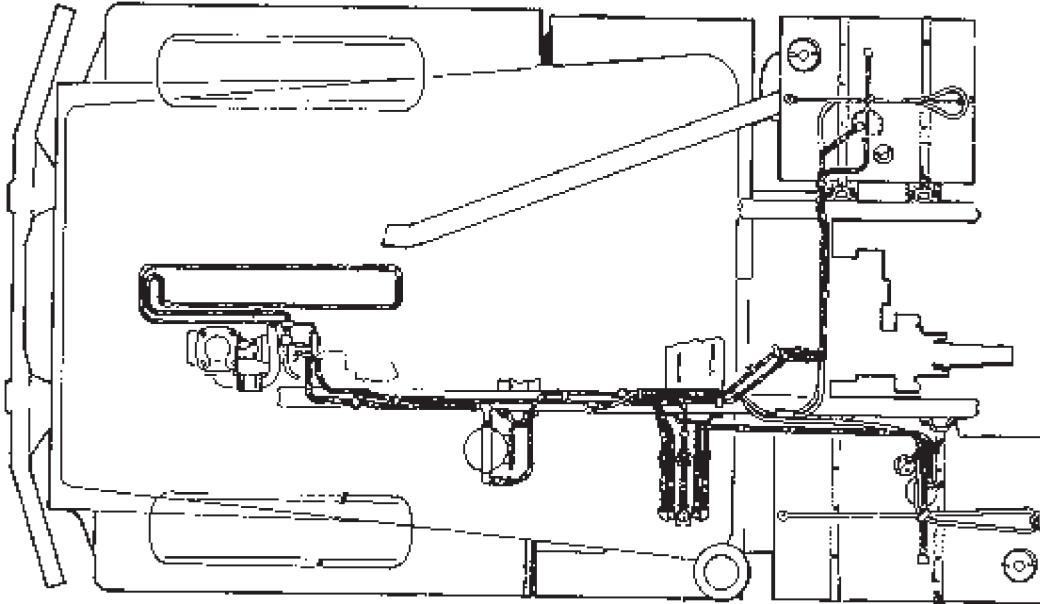
ENGINE CRANKS BUT DOES NOT START - Continued

T0039DAA

Figure 11. Fuel System.

- b. Check fuel shut off solenoid and circuitry, and emergency fuel shutoff.
- c. Visually inspect AFC standard pump filter for dirty or clogged condition (Volume 2, WP 0259).
- d. Visually inspect fuel pump with VS governor filter for dirty or clogged condition (Volume 2, WP 0260). (M936A1 and M928 models)
- e. Visually check primary fuel filter for leaks or damage (Volume 2, WP 0258).
- f. Check fuel lines and connections for leaks, obstructions, and damage.
- g. Tighten all connections where a leak is detected.

CONDITION/INDICATION

IS FUEL SYSTEM IN GOOD OPERATING CONDITION?

DECISION

NO - Fuel filter leaking or damaged. Replace fuel filter (Volume 2, WP 0258). Go to Step (22) to verify problem is solved.

NO - Bad fuel lines. Replace fuel lines (Volume 2, WP 0254). Go to Step (22) to verify problem is solved.

NO - Bad AFC standard pump filter. Replace AFC standard pump filter filter (Volume 2, WP 0259). Go to Step (22) to verify problem is solved.

NO - Bad fuel pump with VS governor filter. Replace fuel pump with VS governor filter (Volume 2, WP 0260). Go to Step (22) to verify problem is solved.

YES - Go to Step (12).

ENGINE CRANKS BUT DOES NOT START - Continued**STEP**

12. DOES ENGINE CRANKING SPEED REACH 100 RPM?
- a. Pull out ENG STOP lever to shut off fuel.

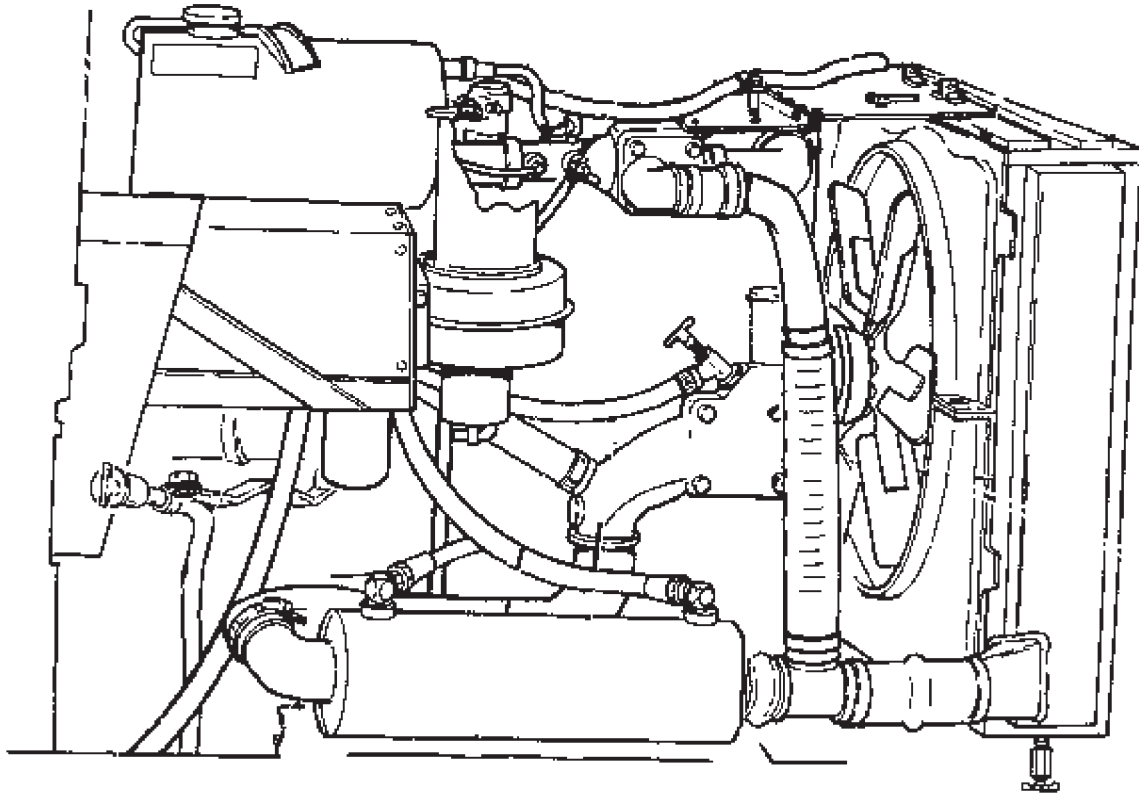

T0065DAA

Figure 12. Engine.

- b. Crank the engine and check of engine cranks at normal speed.

CONDITION/INDICATION

DOES ENGINE CRANKING SPEED REACH 100 RPM?

DECISION

NO - Perform Starter Motor Inoperative troubleshooting (WP 0086).
YES - Go to Step (13).

ENGINE CRANKS BUT DOES NOT START - Continued**STEP****13. IS FUEL CONTAMINATED?**

- a. Open drain valves at fuel filter and drain approximately 1 pt (0.473 L) of fuel into glass container.

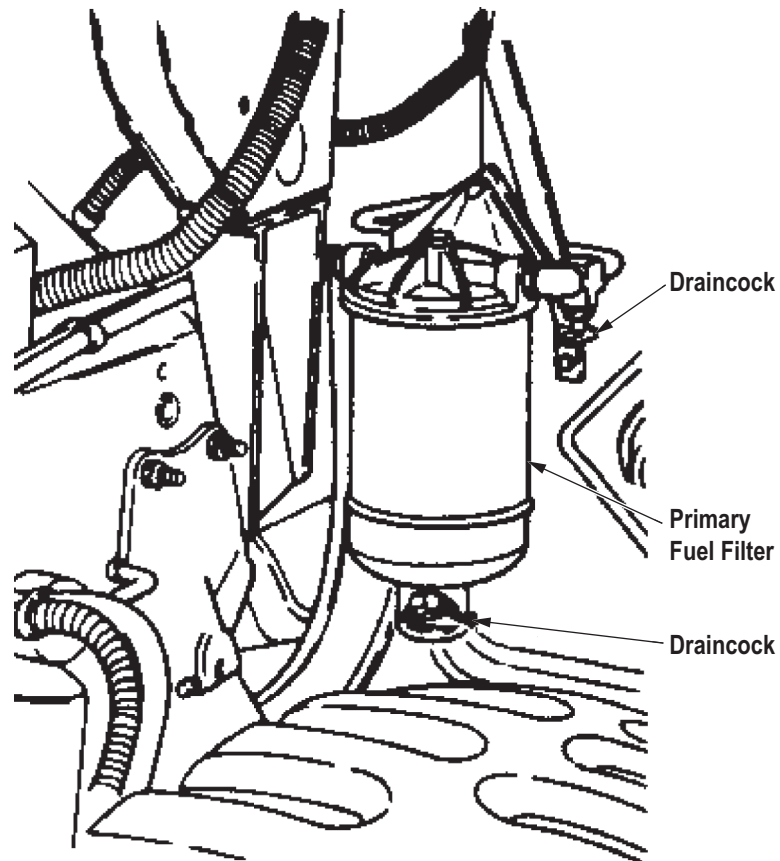

T0368DAA

Figure 13. Fuel Filter.

- b. Check if fuel is contaminated.

CONDITION/INDICATION

IS FUEL CONTAMINATED?

DECISION

YES - Go to Step (14).

NO - Go to Step (16).

ENGINE CRANKS BUT DOES NOT START - Continued**STEP****14. IS FUEL CONTAMINATED?**

- a. Open drain valves at fuel filter and continue to drain fuel up to 1 qt (0.946 L) of fuel into glass container.

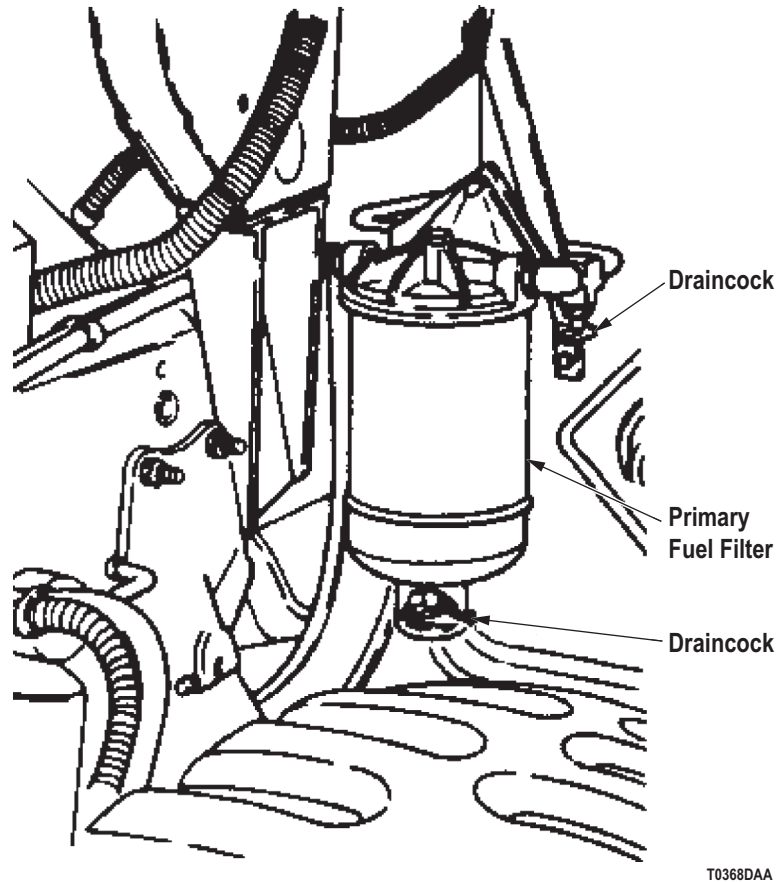

T0368DAA

Figure 14. Fuel Filter.

- b. Check if fuel is contaminated.

CONDITION/INDICATION

IS FUEL CONTAMINATED?

DECISION

YES - Go to Step (15).

NO - Go to Step (16).

STEP**15. DOES ENGINE START AFTER CLEANING FUEL SYSTEM?**

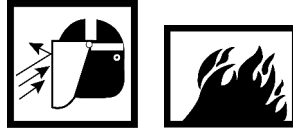
ENGINE CRANKS BUT DOES NOT START - Continued**WARNING**

- Eyeshields must be worn when cleaning with compressed air. Compressed air source will not exceed 30 psi (207 kPa). Failure to comply may result in injury or death to personnel.
 - Diesel fuel is highly flammable. Do not perform fuel system procedures near open flame. Failure to comply may result in injury or death to personnel.
- a. Drain fuel tank (Volume 2, WP 0250).

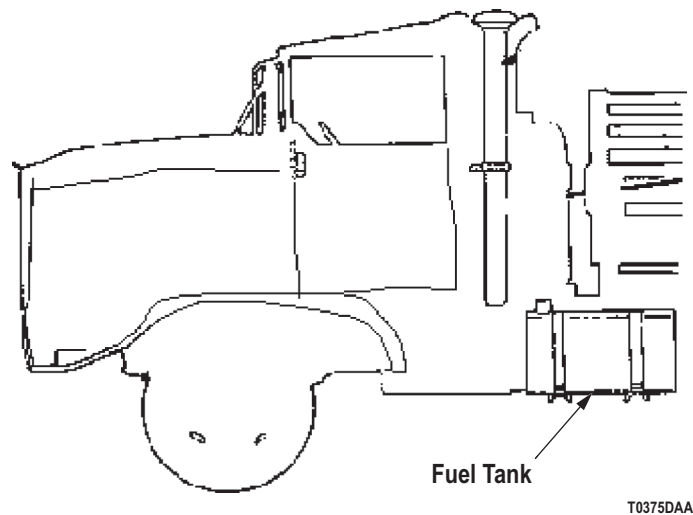

Figure 15. Fuel Tank.

- b. Clean and flush fuel system. Dry with compressed air.
- c. Replace fuel filter (Volume 2, WP 0258).
- d. Refill tank with fuel.
- e. Prime fuel system M939/A1 (TM 9-2320-272-10), M939A2 (Volume 2, WP 0239).
- f. Verify ENG STOP lever is pushed in and emergency shutoff valve is reset (TM 9-2320-272-10).
- g. Attempt to start engine.

CONDITION/INDICATION

DOES ENGINE START AFTER CLEANING FUEL SYSTEM?

DECISION

NO - Go to Step (16).
 YES - Problem fixed.

ENGINE CRANKS BUT DOES NOT START - Continued

STEP

16. IS ETHER CYLINDER EMPTY?

- a. Remove ether cylinder from valve (Volume 2, WP 0263).

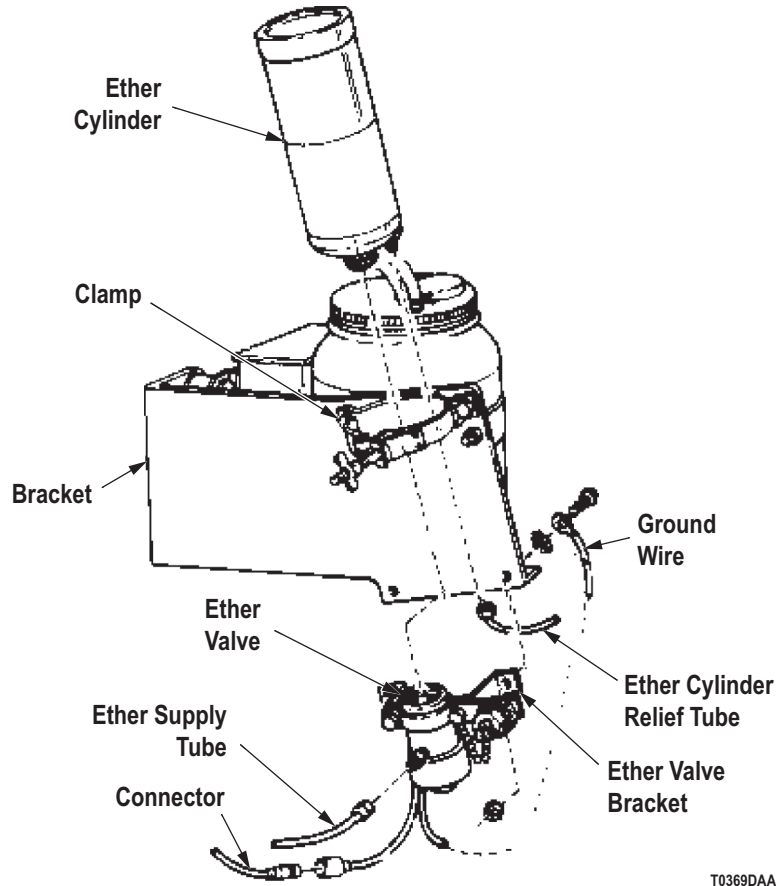

Figure 16. Ether Start System.

- b. Shake ether cylinder and listen for liquid splashing inside.

CONDITION/INDICATION

IS ETHER CYLINDER EMPTY?

DECISION

YES - Replace empty ether cylinder with a full cylinder (Volume 2, WP 0263). Go to Step (22) to verify problem is solved.
 NO - Go to Step (17).

STEP

17. DOES ETHER VALVE OPERATE PROPERLY?

ENGINE CRANKS BUT DOES NOT START - Continued**WARNING**

Ether is extremely flammable. Do not perform ether start system testing procedures near fire. Failure to comply may result in injury or death to personnel.

- a. Disconnect tubing at ether valve (Volume 2, WP 0263).

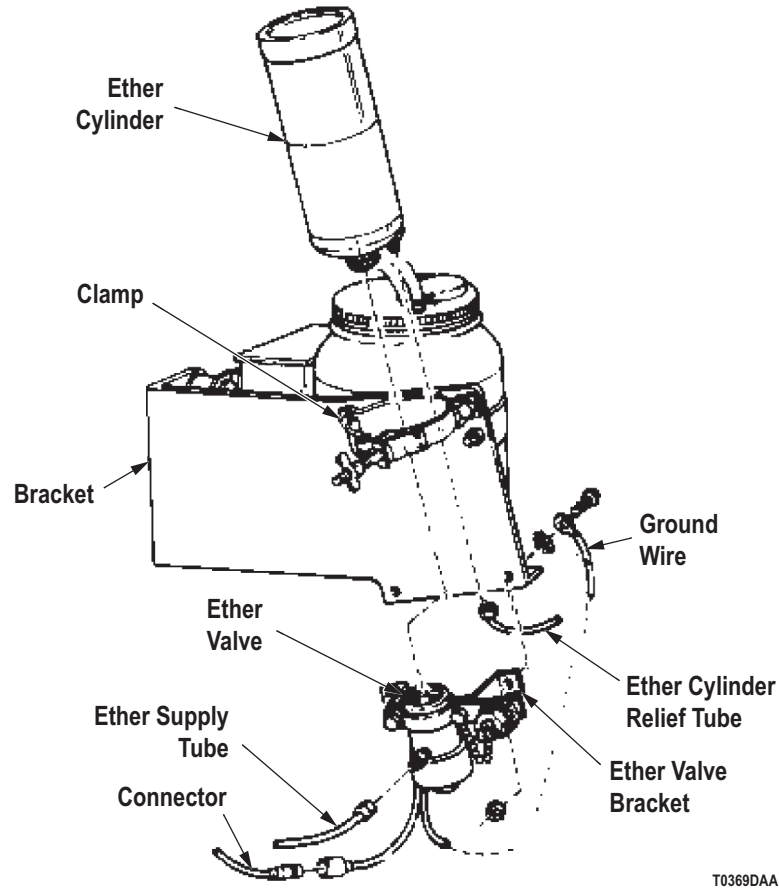

T0369DAA

Figure 17. Ether Start System.

- b. Watch for a small amount of ether being released by ether valve while pressing ether start switch.

CONDITION/INDICATION

DOES ETHER VALVE OPERATE PROPERLY?

DECISION

YES - Go to Step (18).

NO - Perform Engine Cranks But Will Not Start In Cold Weather troubleshooting (WP 0021).

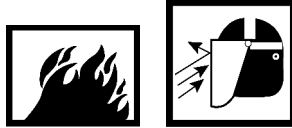
ENGINE CRANKS BUT DOES NOT START - Continued**STEP****18. IS THE THERMAL CLOSE VALVE OR TUBING RESTRICTED?****WARNING**

- Ether is extremely flammable. Do not perform ether start system testing procedures near fire. Failure to comply may result in injury or death to personnel.
- Eyeshields must be worn when cleaning with compressed air. Compressed air source will not exceed 30 psi (207 kPa). Failure to comply may result in injury or death to personnel.

- a. Verify thermal close valve is cold.

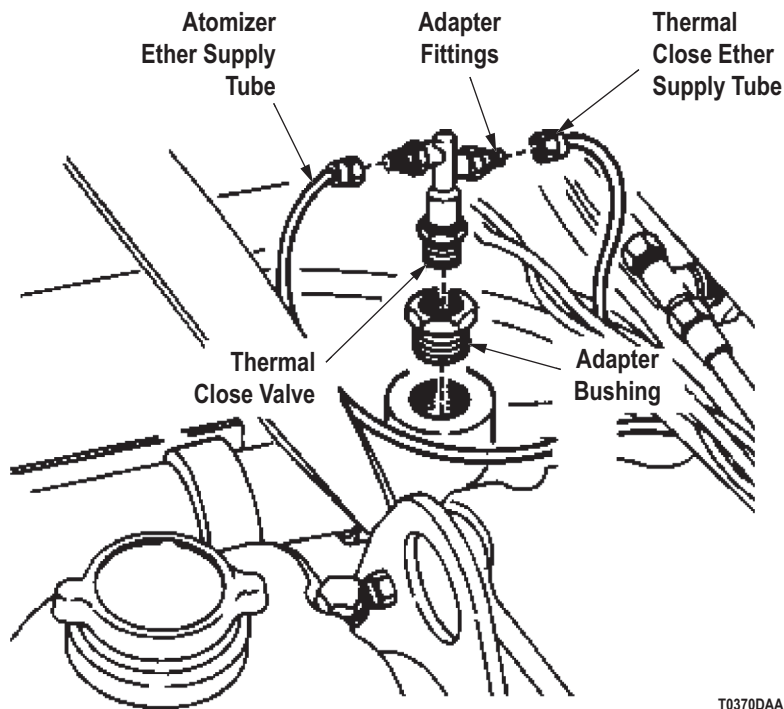

T0370DAA

Figure 18. Thermal Close Valve.

- b. Disconnect ether valve to thermal close valve tubing at ether valve (Volume 2, WP 0263).
- c. Blow compressed air into tubing at ether valve end to determine if system is clear.

ENGINE CRANKS BUT DOES NOT START - Continued

CONDITION/INDICATION

IS THE THERMAL CLOSE VALVE OR TUBING RESTRICTED?

DECISION

YES - Go to Step (19).
 NO - Go to Step (20).

STEP

19. IS THE THERMAL CLOSE VALVE TUBING RESTRICTED?

- a. Disconnect tubing from thermal close valve (Volume 2, WP 0263).

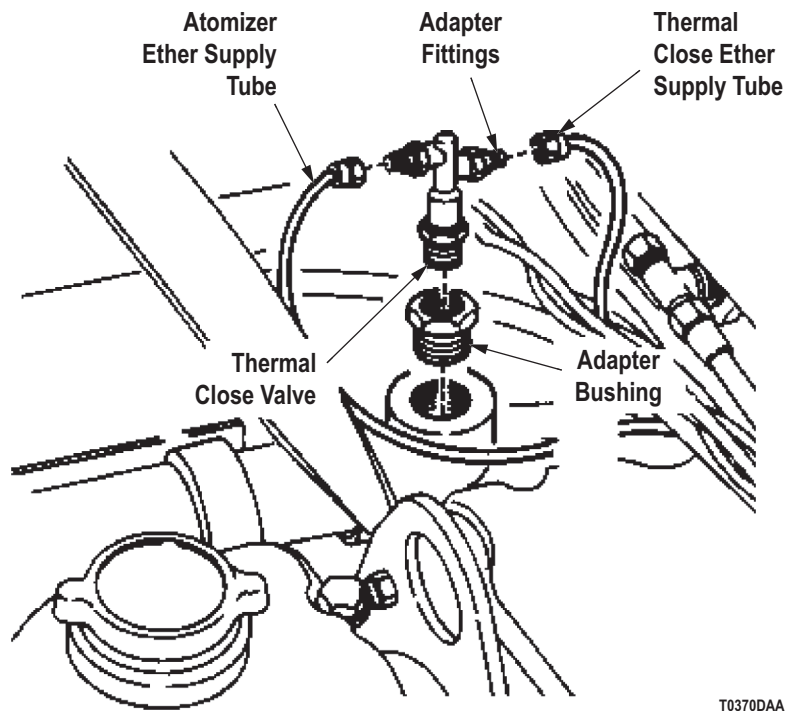

T0370DAA

Figure 19. Thermal Close Valve.

- b. Check for restrictions in tubing.

CONDITION/INDICATION

IS THE THERMAL CLOSE VALVE TUBING RESTRICTED?

DECISION

YES - Replace tubing (Volume 2, WP 0263). Go to Step (22) to verify problem is solved.
 NO - Replace thermal close valve (Volume 2, WP 0264). Go to Step (22) to verify problem is solved.

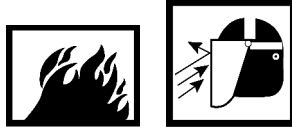
ENGINE CRANKS BUT DOES NOT START - Continued**STEP****20. IS THE ATOMIZER OR ATOMIZER TUBING RESTRICTED?****WARNING**

- Ether is extremely flammable. Do not perform ether start system testing procedures near fire. Failure to comply may result in injury or death to personnel.
- Eyeshields must be worn when cleaning with compressed air. Compressed air source will not exceed 30 psi (207 kPa). Failure to comply may result in injury or death to personnel.

- Reconnect tubing at ether valve (Volume 2, WP 0263).

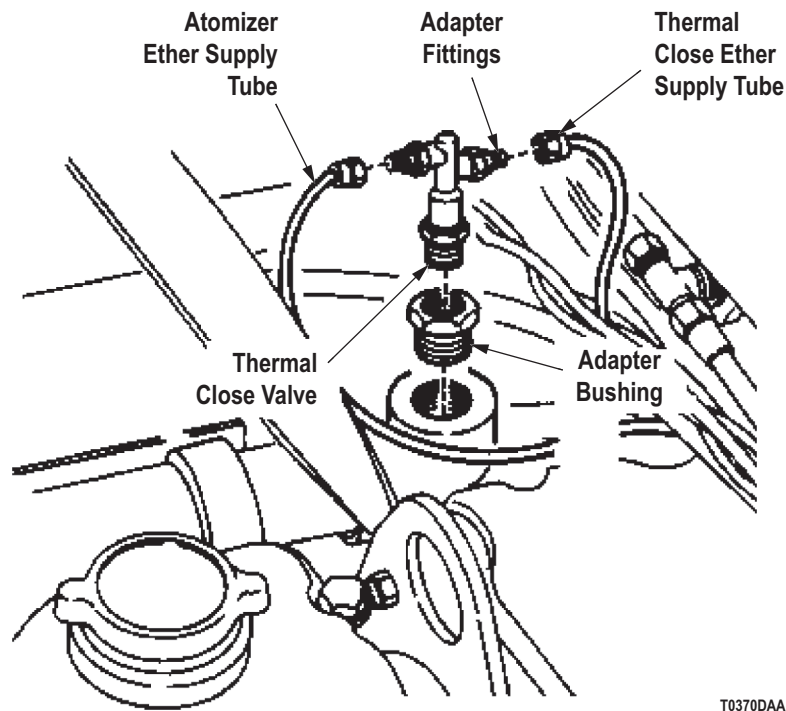

T0370DAA

Figure 20. Thermal Close Valve.

- Disconnect thermal close valve to atomizer tubing at thermal close valve (Volume 2, WP 0264).
- Blow compressed air into tubing at thermal close valve end to determine if system is clear.

ENGINE CRANKS BUT DOES NOT START - Continued**CONDITION/INDICATION**

IS THE ATOMIZER OR ATOMIZER TUBING RESTRICTED?

DECISION

YES - Go to Step (21).

NO - Notify supervisor. It is possible that another troubleshooting work package applies.

STEP

21. IS THE ATOMIZER TUBING RESTRICTED?

- a. Disconnect tubing from atomizer (M939/A1 vehicles) (Volume 2, WP 0265).

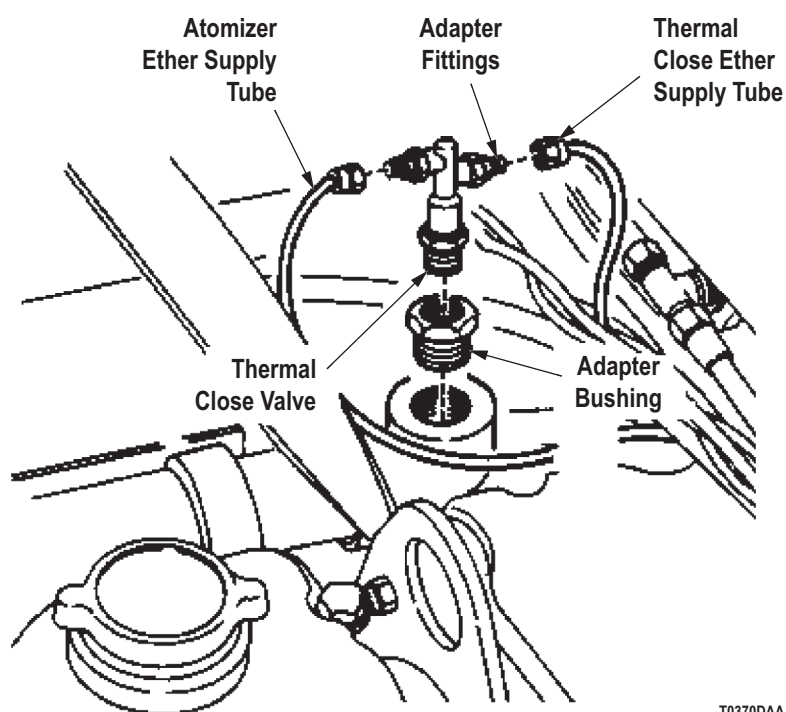

T0370DAA

Figure 21. Thermal Close Valve.

- b. Disconnect tubing from atomizer (M939A2 vehicles) (Volume 2, WP 0266).
 c. Check for restrictions in tubing.

CONDITION/INDICATION

IS THE ATOMIZER TUBING RESTRICTED?

DECISION

YES - Replace tubing (Volume 2, WP 0263). Go to Step (22) to verify problem is solved.

NO - Replace atomizer M939/A1 (Volume 2, WP 0265), M939A2 (Volume 2, WP 0266). Go to Step (22) to verify problem is solved.

ENGINE CRANKS BUT DOES NOT START - Continued**STEP**

22. IS YOUR ORIGINAL PROBLEM STILL PRESENT?

- a. Ensure vehicle is returned to normal operating condition.
- b. Check to see if your original problem still exists.

CONDITION/INDICATION

IS YOUR ORIGINAL ENGINE CRANK PROBLEM STILL PRESENT?

DECISION

YES - Notify supervisor.
NO - Problem fixed.

END OF WORK PACKAGE

FIELD MAINTENANCE
STARTER CRANKS ENGINE SLOWLY, HARD TO START

INITIAL SETUP:**Tools and Special Tools**

Tool Kit, General Mechanic's: Automotive
(Volume 5, WP 0826, Table 1, Item 56)
Test Set, Electronic Systems
(Volume 5, WP 0826, Table 1, Item 51)

References (cont.)

WP 0087
Volume 2, WP 0232
Volume 5, WP 0820

Personnel Required

(2)

Equipment Condition

Vehicle parked and engine shut down.
(TM 9-2320-272-10)

References

Point to Point Schematics

TROUBLESHOOTING PROCEDURE**STARTER CRANKS ENGINE SLOWLY, HARD TO START****NOTE**

Conduct this malfunction test if engine cranks slowly and is hard to start. This procedure will check for incorrect cold weather oil and a faulty starting system.

STARTER CRANKS ENGINE SLOWLY, HARD TO START - Continued**STEP****1. IS CORRECT OIL IN ENGINE?**

If engine is in cold weather, verify that proper engine oil is being used (Volume 5, WP 0820).

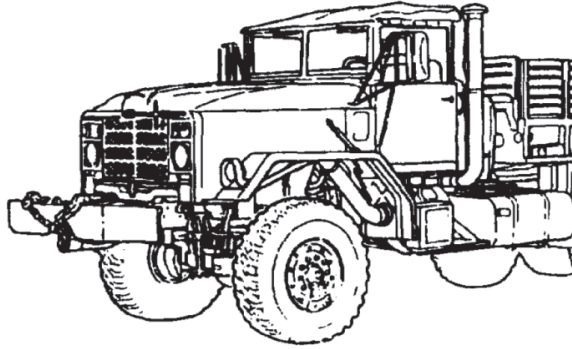

T0374DAA

Figure 1. Engine.

CONDITION/INDICATION

IS CORRECT OIL IN ENGINE?

DECISION

YES - Perform Solenoid Operates, Starter Operates, But Engine Cranks Slowly troubleshooting (WP 0087).
NO - Go to Step (2).

STEP**2. DOES ENGINE START AFTER OIL IS CHANGED?**

- a. Add or replace oil (Volume 2, WP 0232).
- b. Press accelerator pedal down to floor and hold.

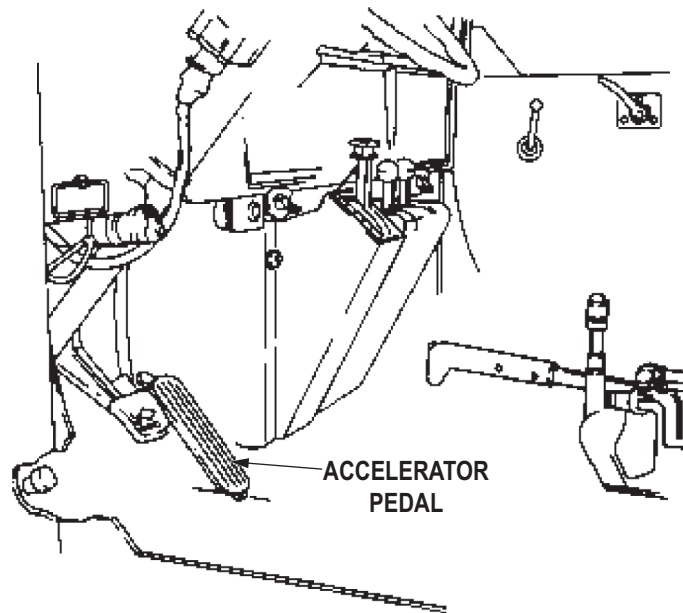
STARTER CRANKS ENGINE SLOWLY, HARD TO START - Continued

T0373DAA

Figure 2. Accelerator Pedal.

- c. Try starting engine.

CONDITION/INDICATION

DOES ENGINE START AFTER OIL IS CHANGED?

DECISION

YES - Go to Step (3).

NO - Perform Solenoid Operates, Starter Operates, But Engine Cranks Slowly troubleshooting (WP 0087).

STEP

3. IS YOUR ORIGINAL ENGINE CRANK PROBLEM STILL PRESENT?
 - a. Ensure vehicle is returned to normal operating condition.
 - b. Check to see if your original engine problem still exists.

CONDITION/INDICATION

IS YOUR ORIGINAL ENGINE CRANK PROBLEM STILL PRESENT?

DECISION

YES - Notify supervisor.

NO - Problem fixed.

END OF WORK PACKAGE

**FIELD MAINTENANCE
ENGINE STOPS DURING NORMAL OPERATION**

INITIAL SETUP:**Tools and Special Tools**

Tool Kit, General Mechanic's: Automotive
(Volume 5, WP 0826, Table 1, Item 56)

Personnel Required

(2)

References

Point to Point Schematics
TM 9-2320-272-10
Volume 2, WP 0239
Volume 2, WP 0243
Volume 2, WP 0251
Volume 2, WP 0254

References (cont.)

Volume 2, WP 0258
Volume 2, WP 0259
Volume 2, WP 0260
Volume 2, WP 0273
Volume 2, WP 0274
Volume 2, WP 0275
Volume 2, WP 0276
Volume 2, WP 0305

Equipment Condition

Vehicle parked and engine shut down.
(TM 9-2320-272-10)

TROUBLESHOOTING PROCEDURE**ENGINE STOPS DURING NORMAL OPERATION****NOTE**

Conduct this malfunction test if engine starts but fails to keep running or engine stops during normal operation. This procedure will check for air intake stack or air cleaner element clogged, fuel level, fuel contamination, fuel transfer pump faulty, fuel pump filter clogged or dirty, primary fuel filter leaking or damaged, fuel supply line faulty, fuel supply line connections loose, fuel tank vent line obstruction, and faulty exhaust system.

ENGINE STOPS DURING NORMAL OPERATION - Continued**STEP**

1. IS AIR CLEANER INDICATOR IN RED ZONE?
 - a. Check air cleaner indicator for fresh air restriction indication.

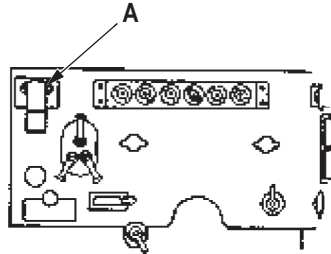

A Air Cleaner Indicator

T0876DAA

Figure 1. Air Cleaner Indicator.

- b. Inspect air intake stack for restrictions.

CONDITION/INDICATION

IS AIR CLEANER INDICATOR IN RED ZONE?

DECISION

- YES - Perform air cleaner servicing (TM 9-2320-272-10). Go to Step (10) to verify problem is solved.
NO - Go to Step (2).

ENGINE STOPS DURING NORMAL OPERATION - Continued**STEP****2. IS THERE FUEL IN VEHICLE TANK(S)?**

Check fuel level.

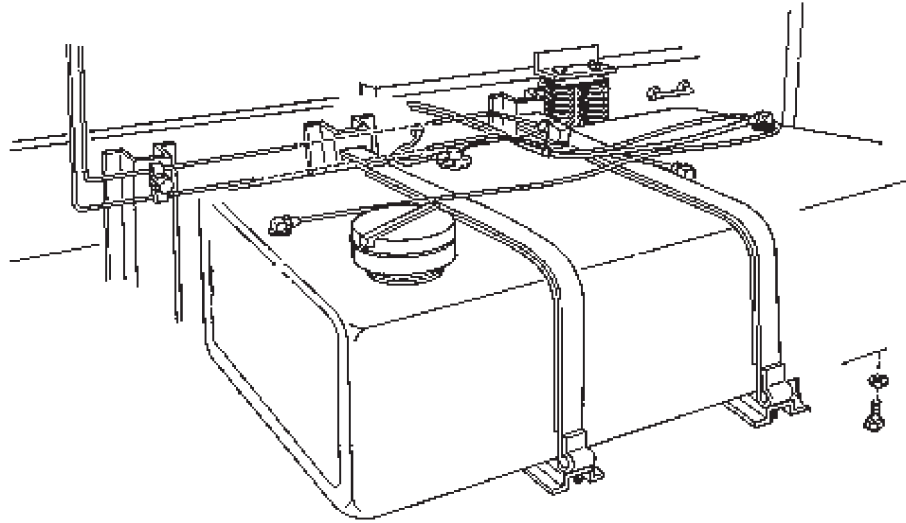

T0048DAA

Figure 2. Fuel Tank.

CONDITION/INDICATION

IS THERE FUEL IN VEHICLE TANK(S)?

DECISION

NO - Fill tank(s) with recommended fuel. Go to Step (10) to verify problem is solved.

YES - Go to Step (3).

ENGINE STOPS DURING NORMAL OPERATION - Continued**STEP****3. IS EMERGENCY FUEL SHUTOFF VALVE IN DISENGAGED POSITION?**

Visually check if emergency shutoff valve is in disengaged position.

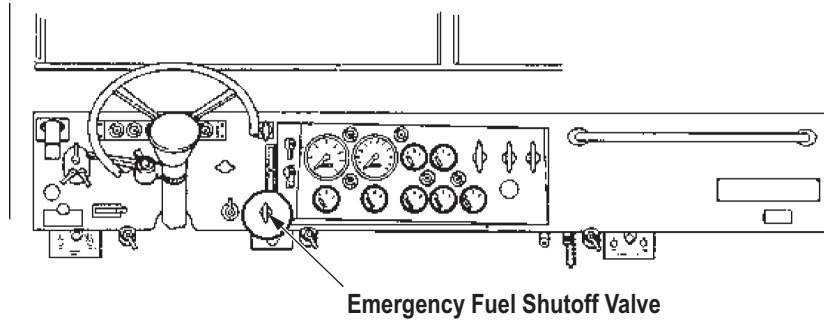

T0073DAA

Figure 3. Emergency Shutoff Valve.

CONDITION/INDICATION

IS EMERGENCY FUEL SHUTOFF VALVE IN DISENGAGED POSITION?

DECISION

YES - Go to Step (4).

NO - Return shutoff valve to disengaged position and reset the emergency shutoff valve (TM 9-2320-272-10).
Go to Step (10) to verify problem is solved.

ENGINE STOPS DURING NORMAL OPERATION - Continued**STEP****4. IS FUEL CONTAMINATED?****NOTE**

Fuel is contaminated if container is 1/4 full of water or contains dirt.

- a. Open drain valves at fuel filters and drain approximately 1 pt (0.473 L) of fuel into glass container.

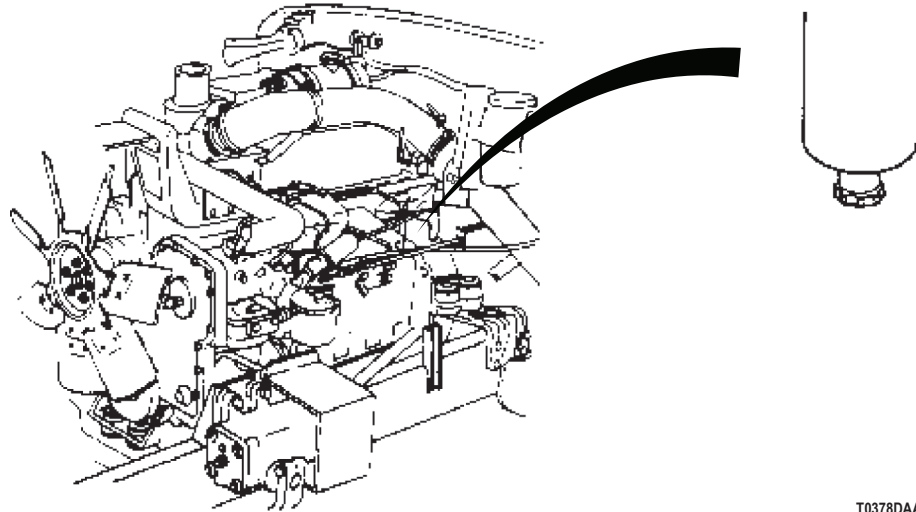

T0378DAA

Figure 4. Fuel Filter.

- b. Check fuel for water and/or dirt contamination.

CONDITION/INDICATION

IS FUEL CONTAMINATED?

DECISION

YES - Go to Step (5).

NO - Go to Step (6) for M939A2. Go to Step (7) for M939/A1.

ENGINE STOPS DURING NORMAL OPERATION - Continued**STEP**

5. DOES ENGINE START AFTER CLEANING FUEL SYSTEM?
 - a. Drain fuel tank (Volume 2, WP 0250).

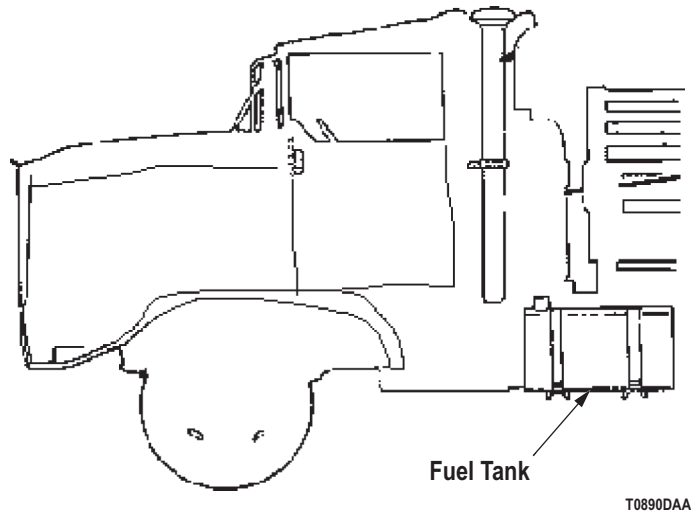

Figure 5. Fuel Tank.

- b. Clean and flush fuel system. Dry with compressed air.
- c. Replace fuel filters (Volume 2, WP 0258).
- d. Refill tank with fuel.
- e. Prime fuel filter M939/A1 (TM 9-2320-272-10), M939A2 (Volume 2, WP 0239).
- f. Attempt to start engine.

CONDITION/INDICATION

DOES ENGINE START AFTER CLEANING FUEL SYSTEM?

DECISION

YES - Go to Step (10) to verify problem is solved.
NO - Go to Step (6) for M939A2. Go to Step (7) for M939/A1.

ENGINE STOPS DURING NORMAL OPERATION - Continued**STEP**

6. IS FUEL TRANSFER PUMP OPERATING PROPERLY?
 - a. Loosen fuel line fitting from filter head (Volume 2, WP 0243).

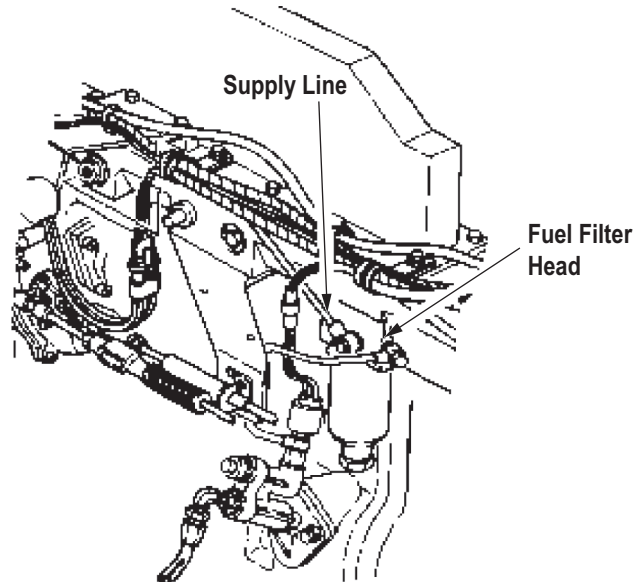

T0398'DAA

Figure 6. Fuel Line.

- b. Operate hand primer on fuel transfer pump.
 - c. Check for fuel leaking out of loosened line at fuel filter head.

CONDITION/INDICATION

IS FUEL TRANSFER PUMP OPERATING PROPERLY?

DECISION

YES - Go to Step (8).

NO - Replace fuel transfer pump (Volume 2, WP 0243). Go to Step (10) to verify problem is solved.

ENGINE STOPS DURING NORMAL OPERATION - Continued**STEP****7. IS FUEL SYSTEM IN GOOD OPERATING CONDITION?****WARNING**

Diesel fuel is highly flammable. Do not perform fuel system procedures near open flame. Failure to comply may result in injury or death to personnel.

- a. Check fuel shut off solenoid and circuitry.

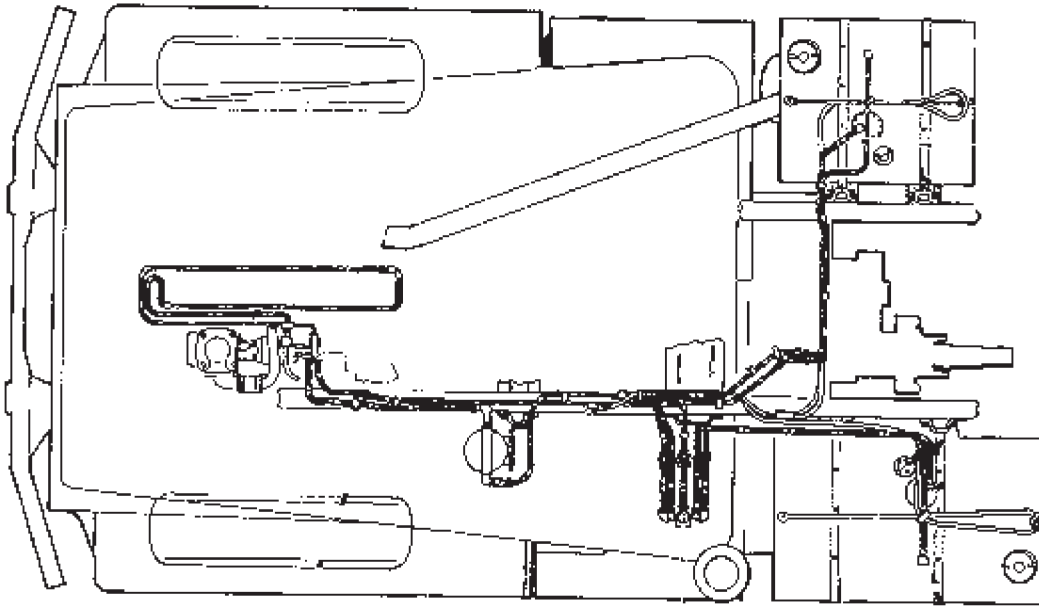

T0879DAA

Figure 7. Fuel System.

- b. Visually inspect AFC standard pump filter for dirty or clogged condition.

NOTE

Perform this step for M936A1 and M928 models.

- c. Visually inspect fuel pump with VC governor filter for dirty or clogged condition.
- d. Visually check primary fuel filter for leaks or damage.
- e. Check fuel lines and connections for leaks, obstructions, and damage.

ENGINE STOPS DURING NORMAL OPERATION - Continued

- f. Tighten all connections where a leak is detected.

CONDITION/INDICATION

IS FUEL SYSTEM IN GOOD OPERATING CONDITION?

DECISION

YES - Go to Step (8).

NO - Fuel filter is leaking or damaged. Replace fuel filter (Volume 2, WP 0258). Go to Step (10) to verify problem is solved.

NO - Fuel lines are bad. Replace tubing (Volume 2, WP 0254). Go to Step (10) to verify problem is solved.

NO - AFC standard pump filter is bad. Replace AFC standard pump filter (Volume 2, WP 0259). Go to Step (10) to verify problem is solved.

NO - VC governor fuel filter is bad (M936A1 and M928 models only). Replace VC governor fuel filter (Volume 2, WP 0260). Go to Step (10) to verify problem is solved.

STEP**8. ARE FUEL TANK VENT LINES UNOBSTRUCTED?**

Remove air vent lines at both ends and clean with compressed air.

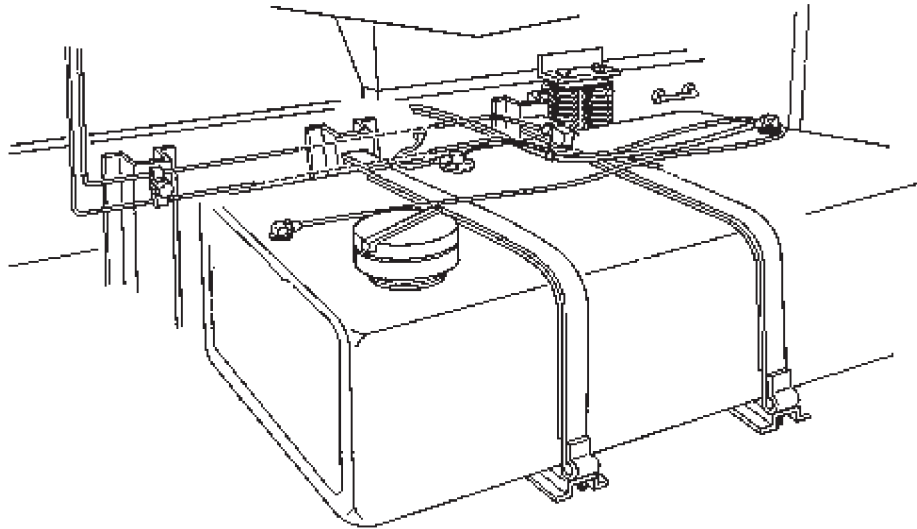

T0074DAA

Figure 8. Vent Lines.

CONDITION/INDICATION

ARE FUEL TANK VENT LINES UNOBSTRUCTED?

DECISION

YES - Go to Step (9).

NO - Replace vent lines and elbow(s) (Volume 2, WP 0254). Go to Step (10) to verify problem is solved.

ENGINE STOPS DURING NORMAL OPERATION - Continued**STEP****9. IS EXHAUST SYSTEM IN GOOD CONDITION?**

Check exhaust system for restriction.

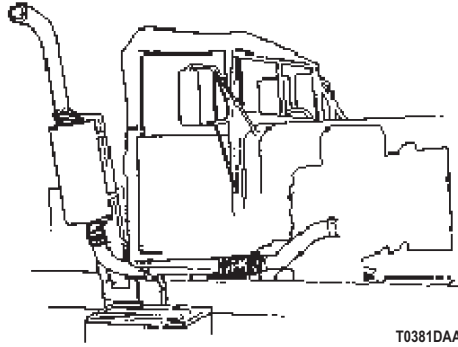

Figure 9. Exhaust System.

CONDITION/INDICATION

IS EXHAUST SYSTEM IN GOOD CONDITION?

DECISION

YES - Go to Step (10) to verify problem is solved.

NO - Front exhaust pipe damaged. Replace front exhaust pipe (Volume 2, WP 0276). Go to Step (10) to verify problem is solved.

NO - Rear exhaust pipe damaged. Replace rear exhaust pipe (Volume 2, WP 0275). Go to Step (10) to verify problem is solved.

NO - Muffler damaged. Replace muffler (Volume 2, WP 0274). Go to Step (10) to verify problem is solved.

NO - Exhaust stack damaged. Replace exhaust stack (Volume 2, WP 0273). Go to Step (10) to verify problem is solved.

STEP**10. IS YOUR ORIGINAL PROBLEM STILL PRESENT?**

a. Ensure vehicle is returned to normal operating condition.

b. Check to see if your original problem still exists.

CONDITION/INDICATION

IS YOUR ORIGINAL PROBLEM STILL PRESENT?

DECISION

YES - Notify supervisor.

NO - Problem fixed.

END OF WORK PACKAGE

FIELD MAINTENANCE
ENGINE STOPS WHEN ACCELERATOR IS RETURNED TO IDLE POSITION

INITIAL SETUP:**Tools and Special Tools**

Tool Kit, General Mechanic's: Automotive
(Volume 5, WP 0826, Table 1, Item 56)

Personnel Required

(2)

References

Point to Point Schematics

References (cont.)

Volume 2, WP 0240
Volume 2, WP 0242
Volume 2, WP 0268
Volume 2, WP 0269

Equipment Condition

Vehicle parked and engine shut down.
(TM 9-2320-272-10)

TROUBLESHOOTING PROCEDURE**ENGINE STOPS WHEN ACCELERATOR IS RETURNED TO IDLE POSITION****NOTE**

Conduct these malfunction tests if engine stops when accelerator is returned to idle position. This procedure will check for proper accelerator linkage adjustment and correct engine idle speed setting.

ENGINE STOPS WHEN ACCELERATOR IS RETURNED TO IDLE POSITION - Continued**STEP****1. IS ACCELERATOR LINKAGE PROPERLY ADJUSTED AND IN GOOD CONDITION?**

Inspect accelerator linkage for damage and proper adjustment.

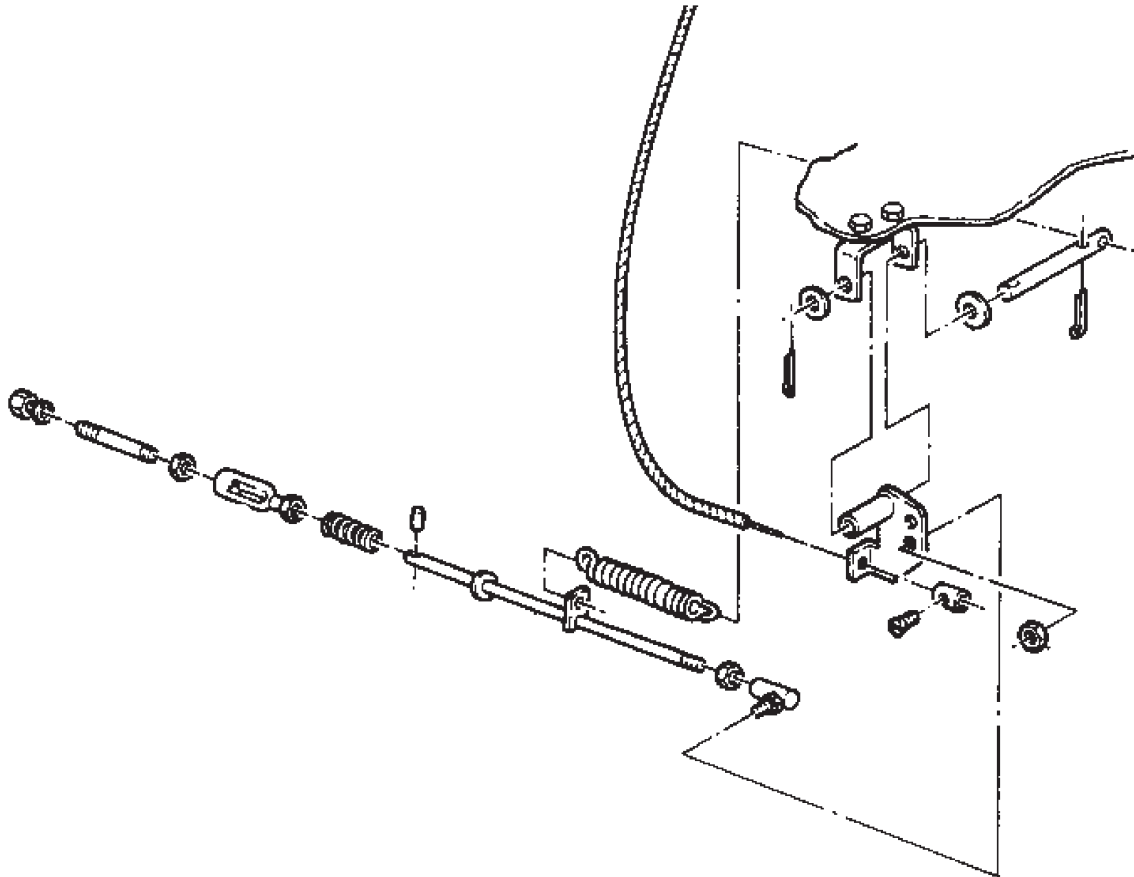

T0390DAA

Figure 1. Accelerator Linkage.

CONDITION/INDICATION

IS ACCELERATOR LINKAGE PROPERLY ADJUSTED AND IN GOOD CONDITION?

DECISION

YES - Go to Step (2).

NO - Replace/adjust accelerator linkage M939/A1 (Volume 2, WP 0268), M939A2 (Volume 2, WP 0269). Go to Step (3) to verify problem is solved.

ENGINE STOPS WHEN ACCELERATOR IS RETURNED TO IDLE POSITION - Continued**STEP**

2. IS ENGINE IDLE SPEED SET BETWEEN 600-650 RPM?
 - a. Start engine.
 - b. Check if tachometer reads between 600 to 650 RPM at idle.

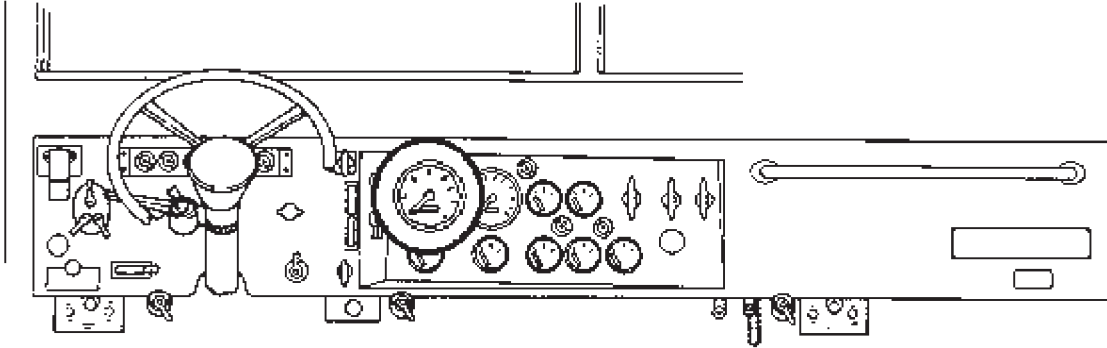

T0054DAA

*Figure 2. Tachometer.***CONDITION/INDICATION**

IS ENGINE IDLE SPEED SET BETWEEN 600-650 RPM?

DECISION

YES - Go to Step (3) to verify problem is solved.
NO - Adjust engine idle RPM M939/A1 (Volume 2, WP 0240), M939/A2 (Volume 2, WP 0242). Go to Step (3) to verify problem is solved.

STEP

3. IS YOUR ORIGINAL ENGINE RUNNING PROBLEM STILL PRESENT?
 - a. Ensure vehicle is returned to normal operating condition.
 - b. Check to see if your original problem still exists.

CONDITION/INDICATION

IS YOUR ORIGINAL ENGINE RUNNING PROBLEM STILL PRESENT?

DECISION

YES - Notify supervisor.
NO - Problem fixed.

END OF WORK PACKAGE

**FIELD MAINTENANCE
ENGINE FAILS TO STOP**

INITIAL SETUP:**Tools and Special Tools**

Tool Kit, General Mechanic's: Automotive
(Volume 5, WP 0826, Table 1, Item 56)

References (cont.)

Volume 2, WP 0271
Volume 2, WP 0304

Personnel Required

(2)

Equipment Condition

Vehicle parked and engine shut down.
(TM 9-2320-272-10)

References

Point to Point Schematics

TROUBLESHOOTING PROCEDURE**ENGINE FAILS TO STOP****NOTE**

Conduct these malfunction tests if engine fails to stop. This procedure will check the emergency stop control cable, and throttle control solenoid operation.

ENGINE FAILS TO STOP - Continued**STEP****1. IS EMERGENCY STOP CONTROL CABLE IN GOOD WORKING CONDITION?**

Visually check emergency stop cable for breaks, binding, and proper adjustment.

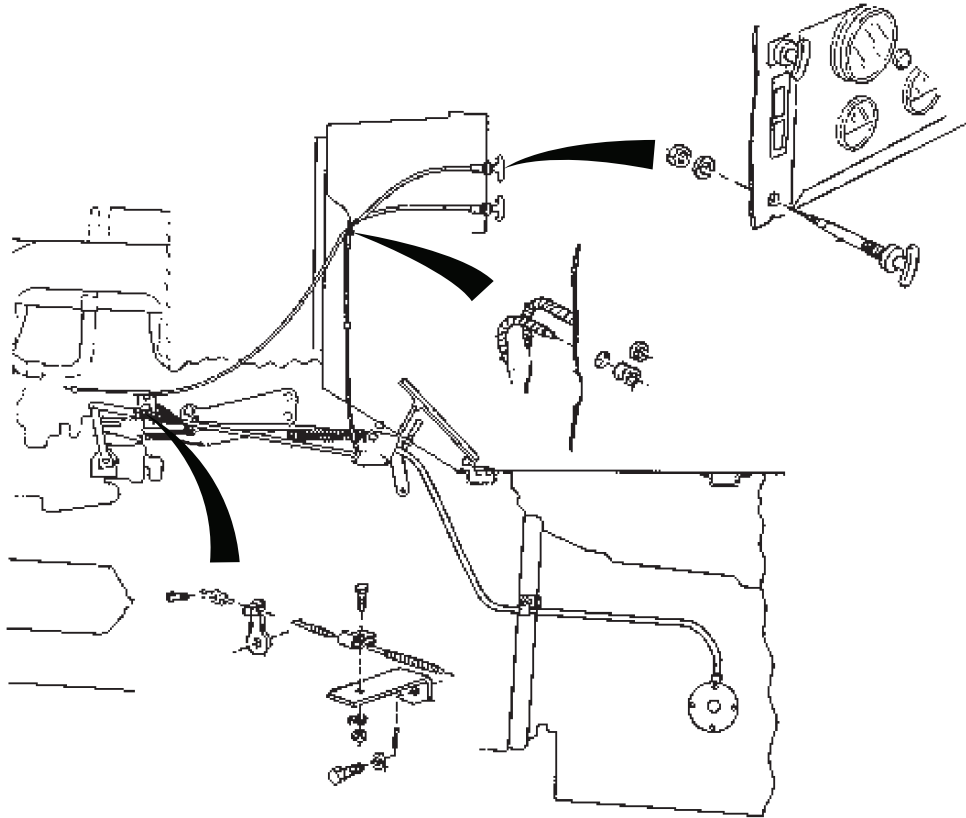

T0396DAA

Figure 1. Emergency Stop Cable.

CONDITION/INDICATION

IS EMERGENCY STOP CONTROL CABLE IN GOOD WORKING CONDITION?

DECISION

YES - Go to Step (2).

NO - Repair/replace emergency stop control cable (Volume 2, WP 0271). Go to Step (3) to verify problem is solved.

ENGINE FAILS TO STOP - Continued**STEP**

2. IS THROTTLE CONTROL SOLENOID AND MOUNTING HARDWARE IN GOOD CONDITION?
 - a. Visually check throttle control solenoid mounting hardware for loose or broken components.

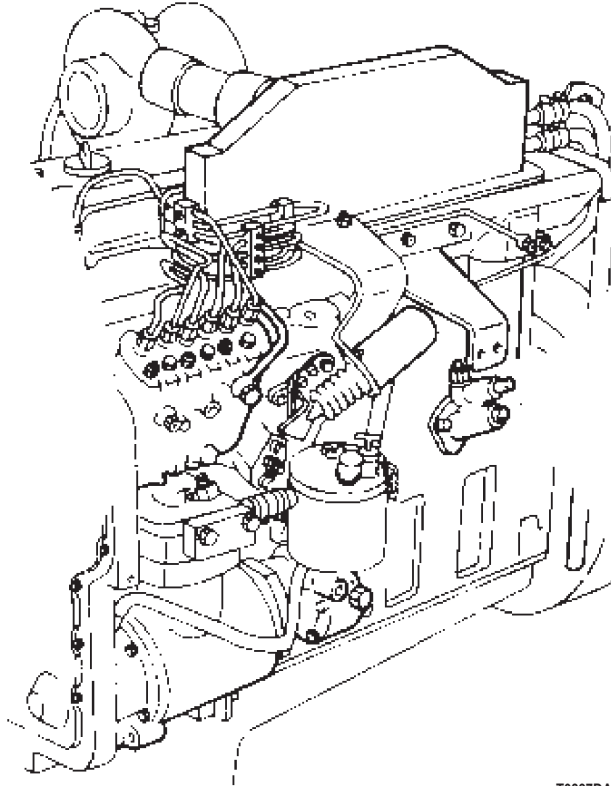

T0397DAA

Figure 2. Throttle Control Solenoid.

- b. Check operation of throttle control solenoid.

CONDITION/INDICATION

IS THROTTLE CONTROL SOLENOID AND MOUNTING HARDWARE IN GOOD CONDITION?

DECISION

YES - Go to Step (3) to verify problem is solved.

NO - Repair mounting hardware or replace solenoid (Volume 2, WP 0304). Go to Step (3) to verify problem is solved.

ENGINE FAILS TO STOP - Continued**STEP**

3. IS YOUR ORIGINAL ENGINE RUNNING PROBLEM STILL PRESENT?
 - a. Ensure vehicle is returned to normal operating condition.
 - b. Check to see if your original engine running problem still exists.

CONDITION/INDICATION

IS YOUR ORIGINAL ENGINE RUNNING PROBLEM STILL PRESENT?

DECISION

YES - Notify supervisor.
NO - Problem fixed.

END OF WORK PACKAGE

**FIELD MAINTENANCE
ENGINE RUNS, BUT MISFIRES**

INITIAL SETUP:**Tools and Special Tools**

Tool Kit, General Mechanic's: Automotive
(Volume 5, WP 0826, Table 1, Item 56)

Personnel Required

(2)

References

Point to Point Schematics
TM 9-2320-272-10
Volume 2, WP 0225

References (cont.)

Volume 2, WP 0239
Volume 2, WP 0251
Volume 2, WP 0254
Volume 2, WP 0258
Volume 2, WP 0268
Volume 2, WP 0269

Equipment Condition

Vehicle parked and engine shut down.
(TM 9-2320-272-10)

TROUBLESHOOTING PROCEDURE**ENGINE RUNS, BUT MISFIRES****NOTE**

Conduct these malfunction tests if engine misfires while running. This procedure will check for fuel contamination, air intake system clogs or restrictions, proper working condition of throttle linkage, fuel line damage, proper fuel supply pressure and engine compression unbalance.

ENGINE RUNS, BUT MISFIRES - Continued**STEP****1. IS FUEL CONTAMINATED?****NOTE**

Fuel is contaminated if container is 1/4 full of water or contains dirt.

- a. Open drain valves at fuel filters and drain approximately 1 pt (0.473 L) of fuel into glass container.

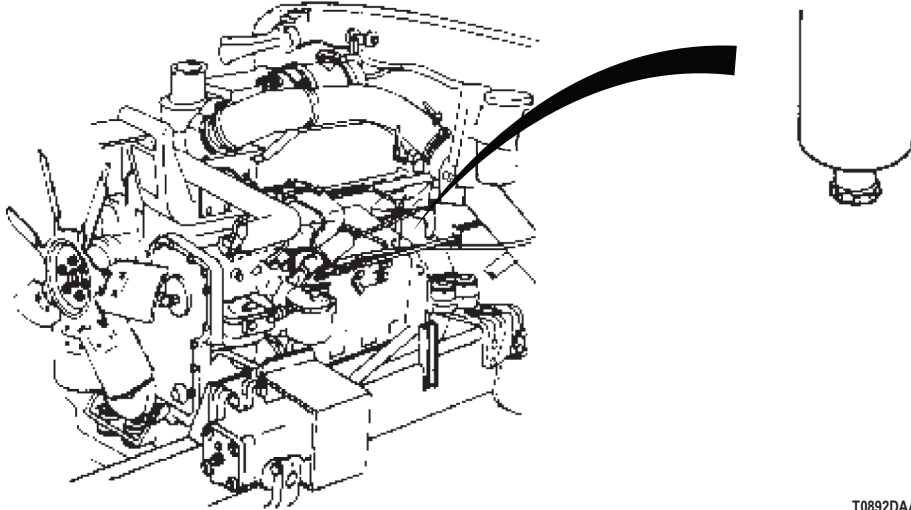

T0892DAA

Figure 1. Fuel Filter.

- b. Check fuel for water and/or dirt contamination.

CONDITION/INDICATION

IS FUEL CONTAMINATED?

DECISION

- YES - Go to Step (2).
NO - Go to Step (3).

ENGINE RUNS, BUT MISFIRES - Continued**STEP**

2. DOES ENGINE RUN WITHOUT MISFIRING AFTER CLEANING FUEL SYSTEM?
 - a. Drain fuel tank (Volume 2, WP 0250).

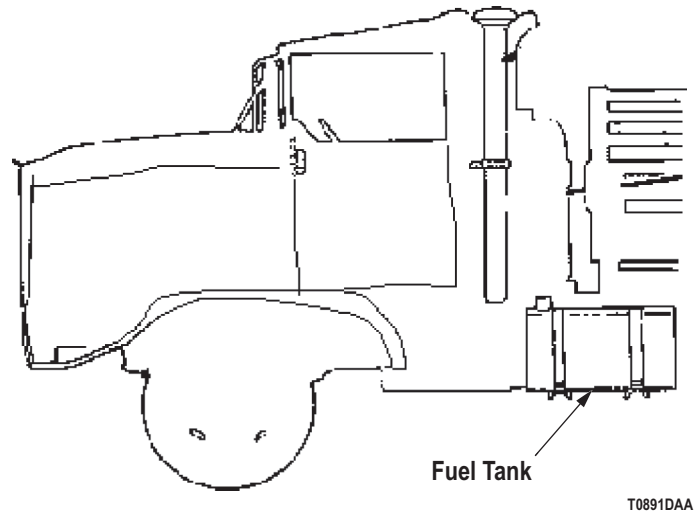

Figure 2. Fuel Tank.

- b. Clean and flush fuel system. Dry with compressed air.
- c. Replace fuel filters (Volume 2, WP 0258).
- d. Refill tank with fuel.
- e. Prime fuel filter M939/A1 (TM 9-2320-272-10), M939A2 (Volume 2, WP 0239).
- f. Attempt to start engine.

CONDITION/INDICATION

DOES ENGINE RUN WITHOUT MISFIRING AFTER CLEANING FUEL SYSTEM?

DECISION

YES - Go to Step (6) to verify problem is solved.
NO - Go to Step (3).

ENGINE RUNS, BUT MISFIRES - Continued**STEP**

3. IS AIR CLEANER INDICATOR IN RED ZONE?
 - a. Check air cleaner indicator for fresh air restriction indication.

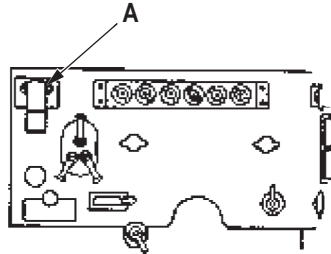

A Air Cleaner Indicator

T0877DAA

Figure 3. Air Cleaner Indicator.

- b. Inspect air intake stack for restrictions.

CONDITION/INDICATION

IS AIR CLEANER INDICATOR IN RED ZONE?

DECISION

YES - Perform air cleaner servicing (TM 9-2320-272-10). Go to Step (6) to verify problem is solved.
NO - Go to Step (4).

ENGINE RUNS, BUT MISFIRES - Continued**STEP****4. IS THROTTLE LINKAGE IN GOOD CONDITION?**

Inspect accelerator linkage for damage and proper adjustment.

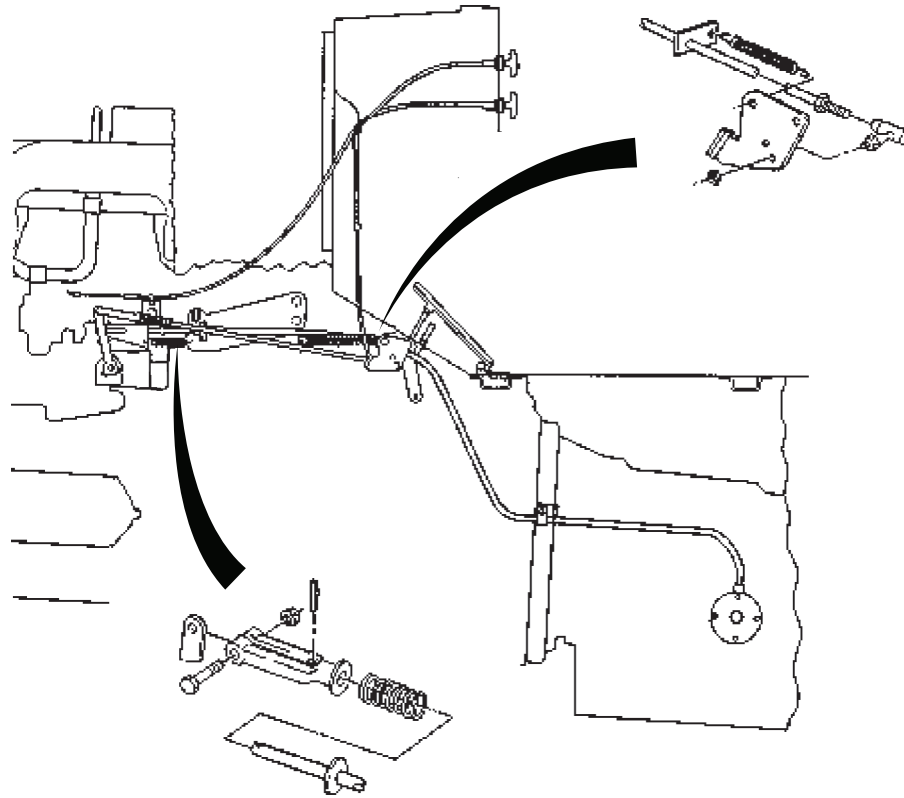

T0053DAA

Figure 4. Throttle Linkage.

CONDITION/INDICATION

IS THROTTLE LINKAGE IN GOOD CONDITION?

DECISION

YES - Go to Step (5).

NO - Replace/adjust accelerator linkage M939/A1 (Volume 2, WP 0268), M939A2 (Volume 2, WP 0269). Go to Step (6) to verify problem is solved.

ENGINE RUNS, BUT MISFIRES - Continued**STEP**

5. ARE FUEL LINES IN GOOD CONDITION?
 - a. Visually inspect fuel lines.

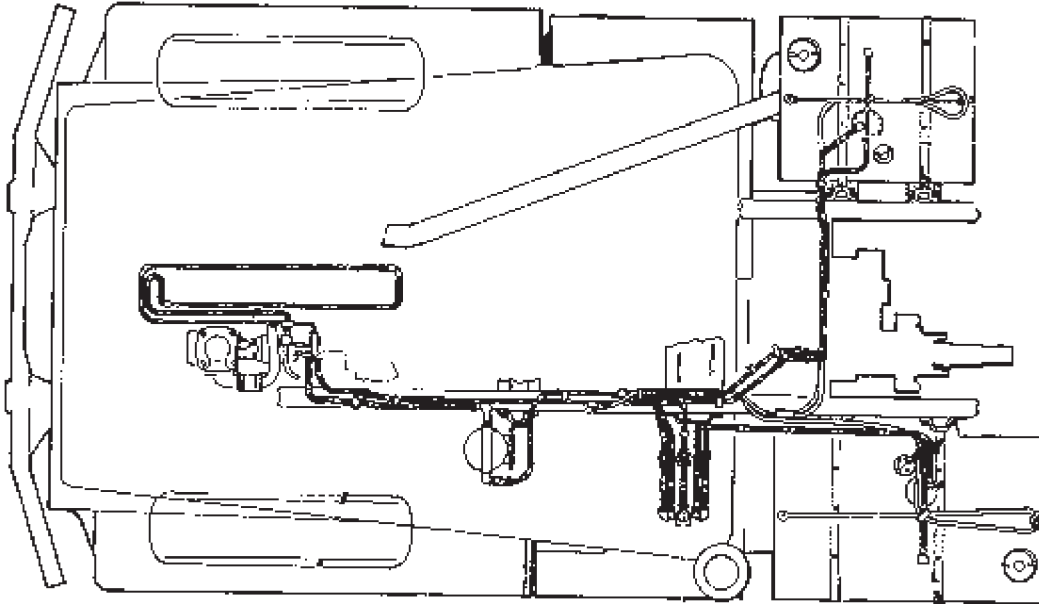

T0880DAA

Figure 5. Fuel Lines.

- b. Check fuel lines and connections for leaks, obstructions and damage.
- c. Tighten connections where leaks are detected.

CONDITION/INDICATION

ARE FUEL LINES IN GOOD CONDITION?

DECISION

YES - Go to Step (6) to verify problem is solved.

NO - Replace defective fuel lines (Volume 2, WP 0254). Go to Step (6) to verify problem is solved.

ENGINE RUNS, BUT MISFIRES - Continued**STEP**

6. IS YOUR ORIGINAL ENGINE FIRING PROBLEM STILL PRESENT?
 - a. Ensure vehicle is returned to normal operating condition.
 - b. Check to see if your original problem still exists.

CONDITION/INDICATION

IS YOUR ORIGINAL ENGINE FIRING PROBLEM STILL PRESENT?

DECISION

YES - Notify supervisor.
NO - Problem fixed.

END OF WORK PACKAGE

**FIELD MAINTENANCE
ENGINE IDLE ROUGH OR ERRATIC**

INITIAL SETUP:**Tools and Special Tools**

Tool Kit, General Mechanic's: Automotive
(Volume 5, WP 0826, Table 1, Item 56)

Equipment Condition

Vehicle parked and engine shut down.
(TM 9-2320-272-10)

Personnel Required

(2)

References

Point to Point Schematics
Volume 2, WP 0241

TROUBLESHOOTING PROCEDURE**ENGINE IDLE ROUGH OR ERRATIC****NOTE**

- Conduct these malfunction test if the engine idle is rough or erratic. This procedure will check for damaged, loose or plugged injector tubes.
- This work package applies only to the M939A2 engine only.

ENGINE IDLE ROUGH OR ERRATIC - Continued**STEP****1. ARE INJECTOR TUBES IN GOOD OPERATING CONDITION?**

Visually check injector tubes for loose, cracked, or pinched condition.

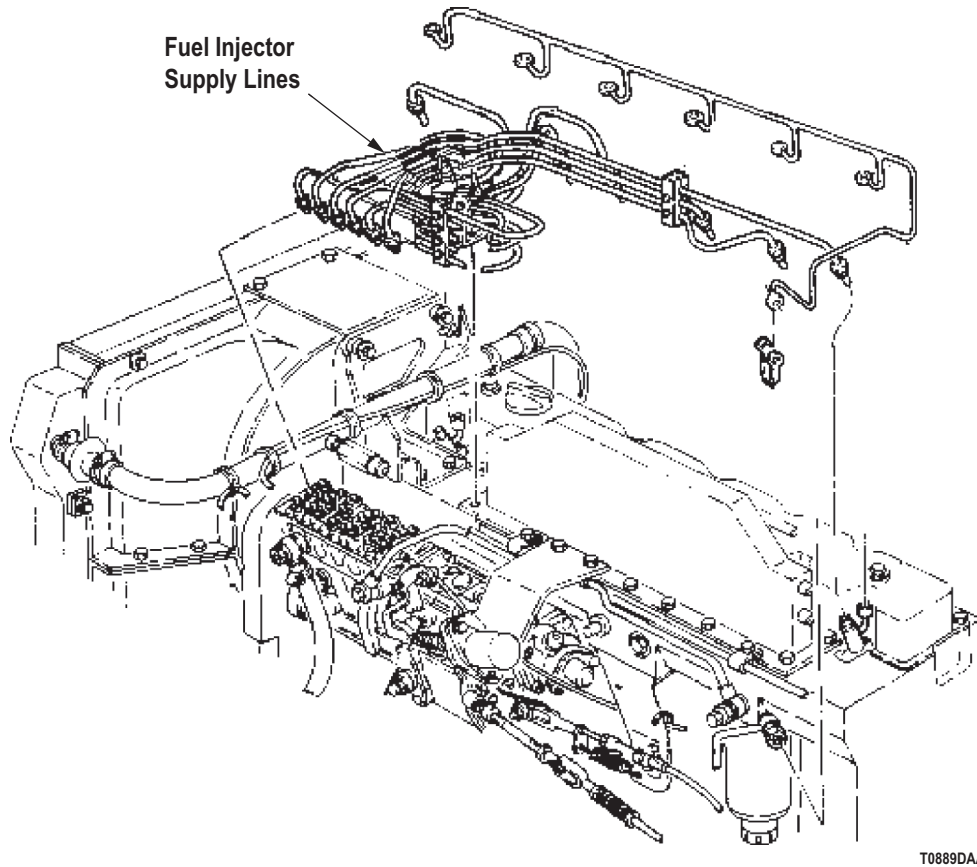

Figure 1. Injector Tubes.

CONDITION/INDICATION

ARE INJECTOR TUBES IN GOOD OPERATING CONDITION?

DECISION

YES - Go to Step (2).

NO - Tighten/replace injector tubes (Volume 2, WP 0241). Go to Step (3) to verify problem is solved.

ENGINE IDLE ROUGH OR ERRATIC - Continued**STEP**

2. ARE INJECTOR TUBES FREE OF PLUGS?
 - a. Remove one injector tube.

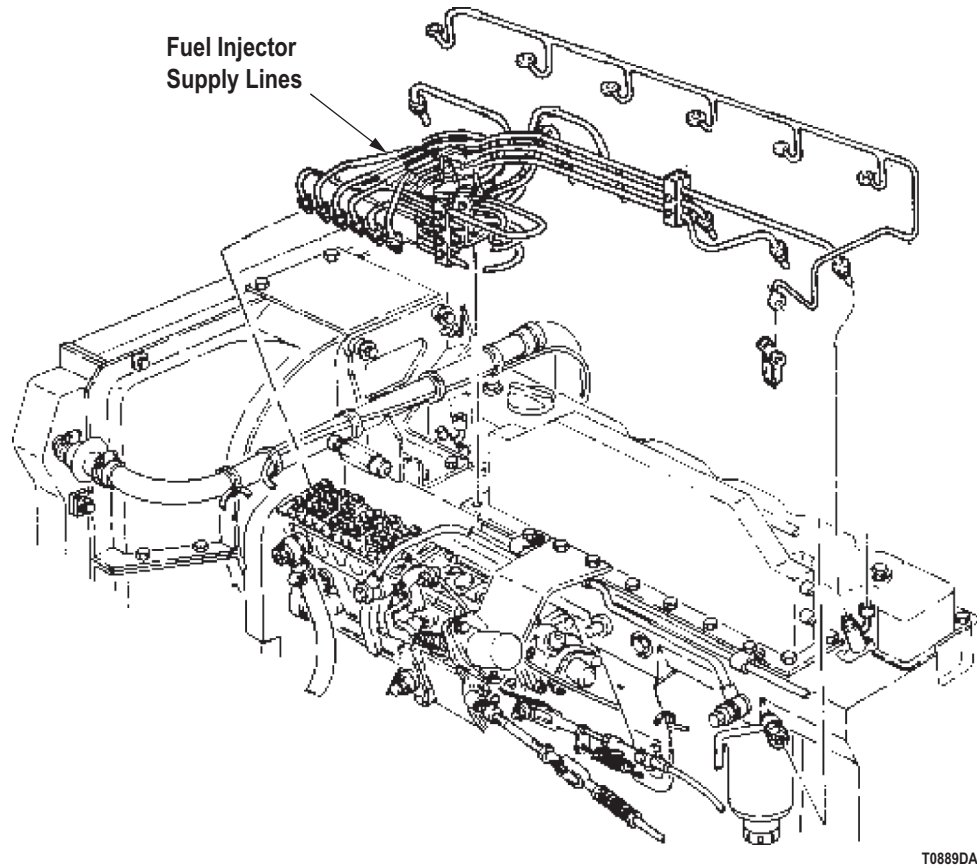

Figure 2. Injector Tubes.

- b. Check injector tube for plugged condition.
 - c. Repeat previous test for other injector tubes.

CONDITION/INDICATION

ARE INJECTOR TUBES FREE OF PLUGS?

DECISION

YES - Notify supervisor. It is possible that another troubleshooting work package applies.

NO - Tighten/replace injector tubes (Volume 2, WP 0241). Go to Step (3) to verify problem is solved.

ENGINE IDLE ROUGH OR ERRATIC - Continued**STEP**

3. IS YOUR ORIGINAL ENGINE IDLE PROBLEM STILL PRESENT?
 - a. Ensure vehicle is returned to normal operating condition.
 - b. Check to see if your original problem still exists.

CONDITION/INDICATION

IS YOUR ORIGINAL ENGINE IDLE PROBLEM STILL PRESENT?

DECISION

YES - Notify supervisor.
NO - Problem fixed.

END OF WORK PACKAGE

**FIELD MAINTENANCE
POOR ACCELERATION AND/OR LACK OF POWER**

INITIAL SETUP:**Tools and Special Tools**

Tool Kit, General Mechanic's: Automotive
(Volume 5, WP 0826, Table 1, Item 56)

Personnel Required

(2)

References

Point to Point Schematics
TM 9-2320-272-10
Volume 2, WP 0243
Volume 2, WP 0244
Volume 2, WP 0249
Volume 2, WP 0254
Volume 2, WP 0258
Volume 2, WP 0259

References (cont.)

Volume 2, WP 0260
Volume 2, WP 0268
Volume 2, WP 0269
Volume 2, WP 0273
Volume 2, WP 0274
Volume 2, WP 0275
Volume 2, WP 0276
Volume 2, WP 0299
Volume 2, WP 0305
Volume 3, WP 0365

Equipment Condition

Vehicle parked and engine shut down.
(TM 9-2320-272-10)

TROUBLESHOOTING PROCEDURE**POOR ACCELERATION AND/OR LACK OF POWER****NOTE**

Conduct this malfunction test if there is poor acceleration or lack of power. This procedure will check for air intake stack or air cleaner element clogged, fuel pump filter clogged or dirty, fuel filter leaking or damaged, fuel supply line faulty, fuel supply line connections loose, exhaust system faulty, throttle level travel out of adjustment, air fuel control (AFC) tube faulty, exhaust leaks, fuel transfer pump faulty, fuel injector supply line clogged, fuel filter clogged and/or dirty, and turbocharger faulty.

POOR ACCELERATION AND/OR LACK OF POWER - Continued**STEP**

1. IS AIR CLEANER INDICATOR IN RED ZONE?
 - a. Check air cleaner indicator for fresh air restriction indication.

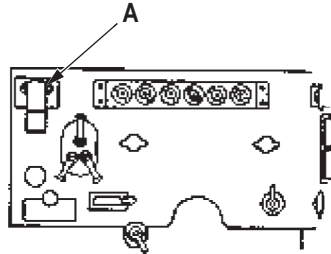

A Air Cleaner Indicator

T0878DAA

Figure 1. Air Cleaner Indicator.

- b. Inspect air intake stack for restrictions.

CONDITION/INDICATION

IS AIR CLEANER INDICATOR IN RED ZONE?

DECISION

- YES - Perform air cleaner servicing (TM 9-2320-272-10). Go to Step (14) to verify problem is solved.
 NO - Go to Step (3) for M939A2. Go to Step (2) for M939/A1.

STEP

2. IS FUEL SYSTEM IN GOOD OPERATING CONDITION?

WARNING

Diesel fuel is highly flammable. Do not perform fuel system procedures near open flame. Failure to comply may result in injury or death to personnel.

- a. Check fuel shut off solenoid and circuitry.

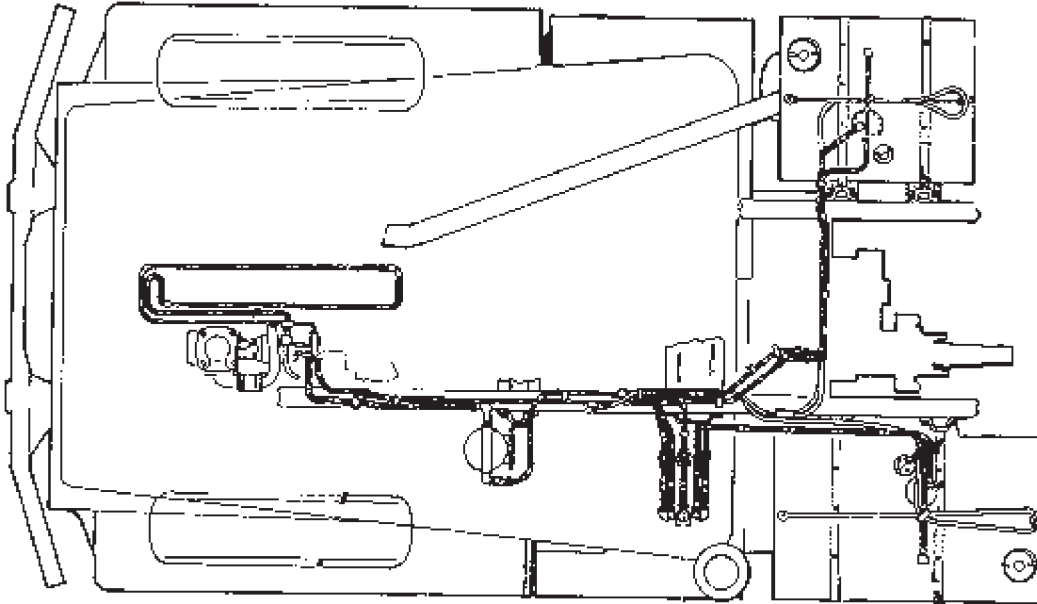
POOR ACCELERATION AND/OR LACK OF POWER - Continued

T0881DAA

Figure 2. Fuel System.

- b. Visually inspect AFC standard pump filter for dirty or clogged condition.

NOTE

Perform this step for M936A1 and M928 models.

- c. Visually inspect fuel pump with VC governor filter for dirty or clogged condition.
- d. Visually check primary fuel filter for leaks or damage.
- e. Check fuel lines and connections for leaks, obstructions, and damage.
- f. Tighten all connections where a leak is detected.

CONDITION/INDICATION

IS FUEL SYSTEM IN GOOD OPERATING CONDITION?

DECISION

YES - Go to Step (3).

NO - Fuel filter is leaking or damaged. Replace fuel filter (Volume 2, WP 0258). Go to Step (14) to verify problem is solved.

NO - Fuel lines are bad. Replace tubing (Volume 2, WP 0254). Go to Step (14) to verify problem is solved.

NO - AFC standard pump filter is bad. Replace AFC standard pump filter (Volume 2, WP 0259). Go to Step (14) to verify problem is solved.

NO - VC governor fuel filter is bad (M936A1 and M928 models only). Replace VC governor fuel filter (Volume 2, WP 0260). Go to Step (14) to verify problem is solved.

POOR ACCELERATION AND/OR LACK OF POWER - Continued**STEP****3. IS EXHAUST SYSTEM IS IN GOOD CONDITION?**

Check exhaust system for restriction.

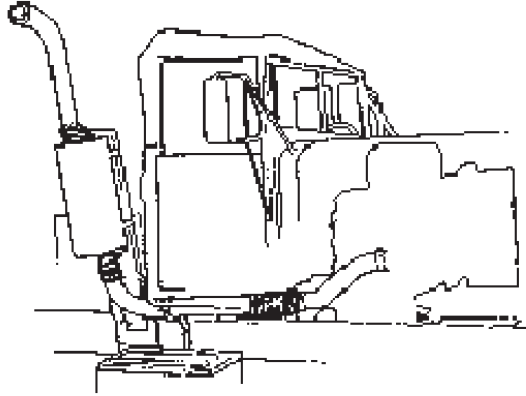

T0893DAA

Figure 3. Exhaust System.

CONDITION/INDICATION

IS EXHAUST SYSTEM IS IN GOOD CONDITION?

DECISION

YES - Go to Step (4) to verify problem is solved.

NO - Front exhaust pipe damaged. Replace front exhaust pipe (Volume 2, WP 0276). Go to Step (14) to verify problem is solved.

NO - Rear exhaust pipe damaged. Replace rear exhaust pipe (Volume 2, WP 0275). Go to Step (14) to verify problem is solved.

NO - Muffler damaged. Replace muffler (Volume 2, WP 0274). Go to Step (14) to verify problem is solved.

NO - Exhaust stack damaged. Replace exhaust stack (Volume 2, WP 0273). Go to Step (14) to verify problem is solved.

POOR ACCELERATION AND/OR LACK OF POWER - Continued**STEP****4. IS ACCELERATOR PEDAL AND THROTTLE LEVER IN GOOD CONDITION?**

Check accelerator pedal and throttle lever for full travel.

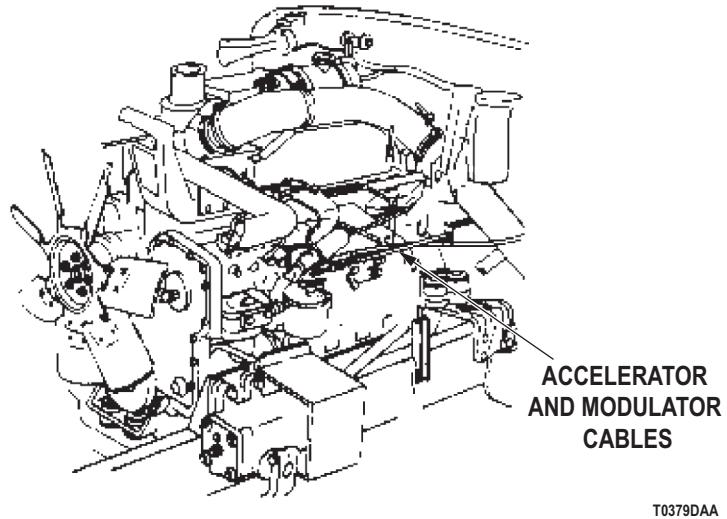

Figure 4. Accelerator Cable.

CONDITION/INDICATION

IS ACCELERATOR PEDAL AND THROTTLE LEVER IN GOOD CONDITION?

DECISION

YES - Go to Step (5).

NO - Adjust throttle level travel M939/A1 (Volume 2, WP 0268), M939A2 (Volume 2, WP 0269). Go to Step (14) to verify problem is solved.

POOR ACCELERATION AND/OR LACK OF POWER - Continued**STEP****5. IS ACCELERATOR LINKAGE OPERATING CORRECTLY?**

Check accelerator linkage for proper operation.

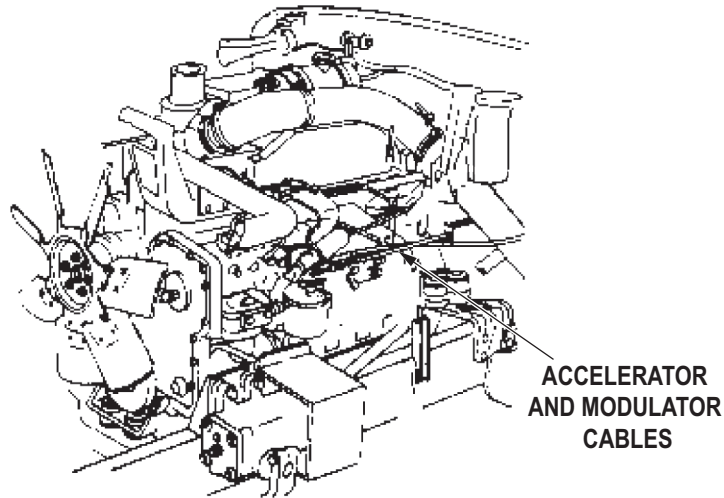

T0379DAA

Figure 5. Accelerator Cable.

CONDITION/INDICATION

IS ACCELERATOR LINKAGE OPERATING CORRECTLY?

DECISION

YES - Go to Step (6).

NO - Adjust or replace accelerator linkage as necessary M939/A1 (Volume 2, WP 0268), M939A2 (Volume 2, WP 0269). Go to Step (14) to verify problem is solved.

POOR ACCELERATION AND/OR LACK OF POWER - Continued**STEP****6. IS MODULATOR CABLE IN GOOD CONDITION?**

Check modulator cable for proper operation.

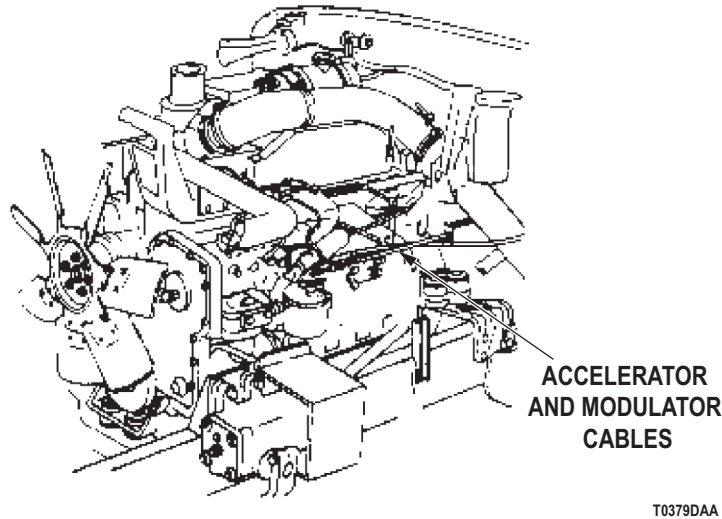

Figure 6. Modulator Cable.

CONDITION/INDICATION

IS MODULATOR CABLE IN GOOD CONDITION?

DECISION

YES - Go to Step (7).

NO - Replace modulator cable (Volume 3, WP 0365). Go to Step (14) to verify problem is solved.

POOR ACCELERATION AND/OR LACK OF POWER - Continued**STEP****7. IS AIR FUEL CONTROL (AFC) TUBE IN GOOD CONDITION?**

Check air fuel control (AFC) tube for leaks and/or restriction.

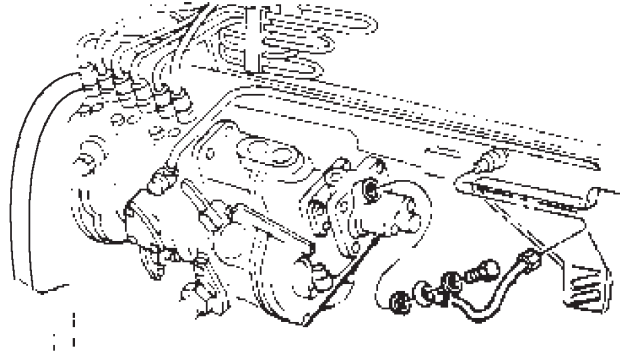

T0382DAA

Figure 7. Air Fuel Control Tube.

CONDITION/INDICATION

IS AIR FUEL CONTROL (AFC) TUBE IN GOOD CONDITION?

DECISION

YES - Go to Step (8).

NO - Replace air fuel control tube (Volume 2, WP 0244). Go to Step (14) to verify problem is solved.

POOR ACCELERATION AND/OR LACK OF POWER - Continued**STEP****8. ARE THERE AIR LEAKS IN EXHAUST SYSTEM?**

- a. Check cross over tube, aftercooler, turbocharger, and exhaust manifold for leaks.

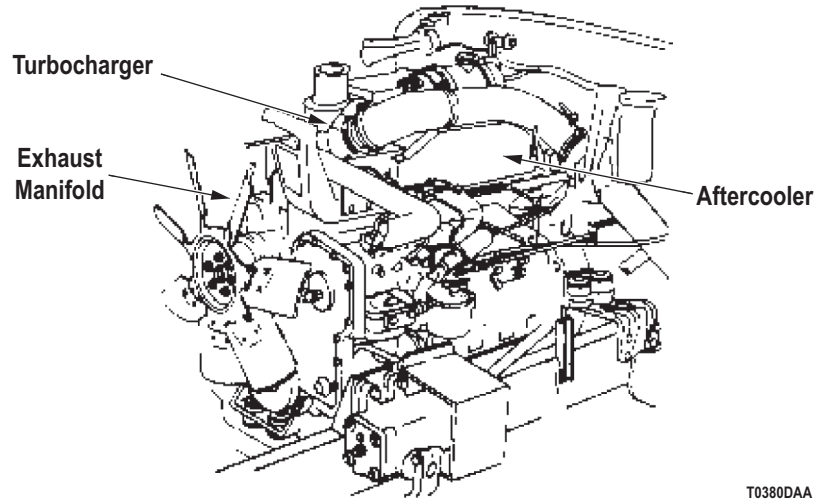

T0380DAA

Figure 8. Exhaust System.

- b. Tighten any loose hose clamps.

CONDITION/INDICATION

ARE THERE AIR LEAKS IN EXHAUST SYSTEM?

DECISION

YES - Aftercooler leaking through gasket. Replace after cooler gasket (Volume 2, WP 0299). Go to Step (14) to verify problem is solved.

YES - Turbocharger leaking through gasket. Replace turbocharger gasket (Volume 2, WP 0249). Go to Step (14) to verify problem is solved.

NO - Go to Step (9).

POOR ACCELERATION AND/OR LACK OF POWER - Continued**STEP****9. IS FUEL LEAKING FROM FUEL TRANSFER PUMP?**

Check for fuel at fuel transfer pump while operating hand primer.

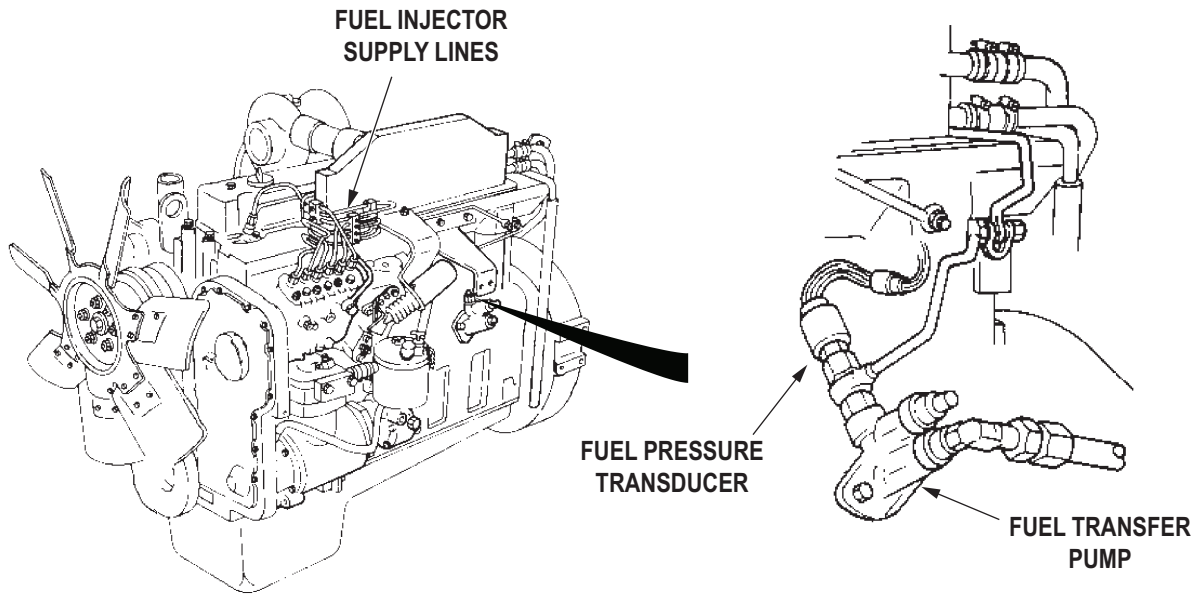

T0384DAA

Figure 9. Fuel Transfer Pump.

CONDITION/INDICATION

IS FUEL LEAKING FROM FUEL TRANSFER PUMP?

DECISION

YES - Replace fuel transfer pump (Volume 2, WP 0243). Go to Step (14) to verify problem is solved.
 NO - Go to Step (10).

POOR ACCELERATION AND/OR LACK OF POWER - Continued**STEP****10. IS FUEL LEAKING FROM FUEL PRESSURE TRANSDUCER?**

Check for fuel leaking from fuel pressure transducer.

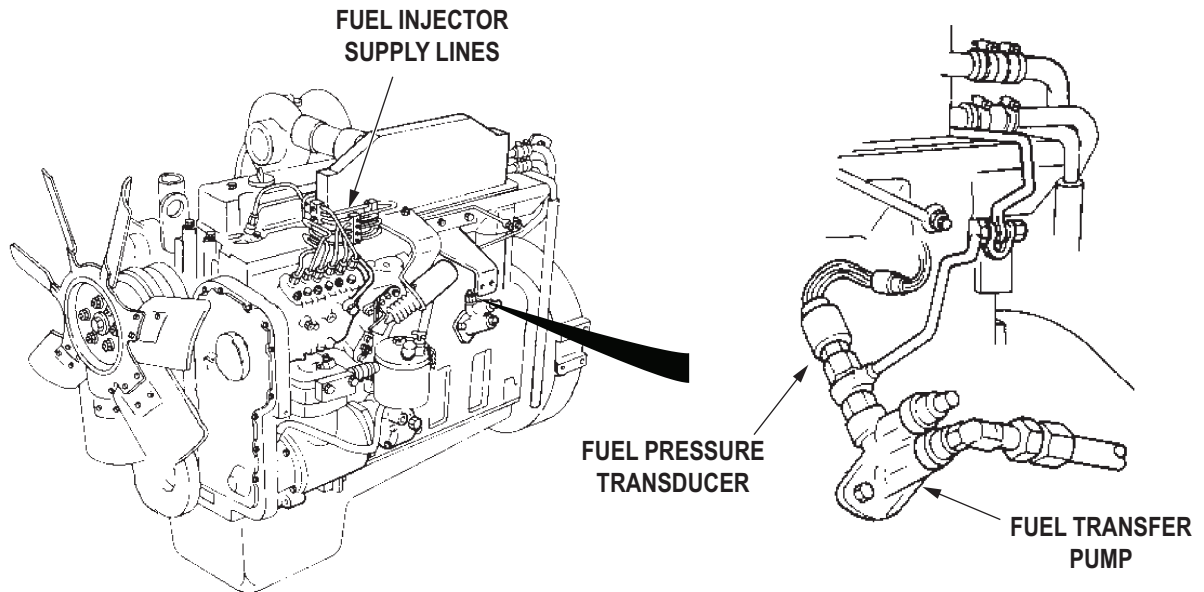

T0384DAA

Figure 10. Fuel Pressure Transducer.

CONDITION/INDICATION

IS FUEL LEAKING FROM FUEL PRESSURE TRANSDUCER?

DECISION

YES - Go to Step (11).
NO - Go to Step (13).

POOR ACCELERATION AND/OR LACK OF POWER - Continued**STEP****11. IS FUEL INJECTOR SUPPLY LINE CLOGGED?**

Disconnect fuel injector supply lines and check for clogs.

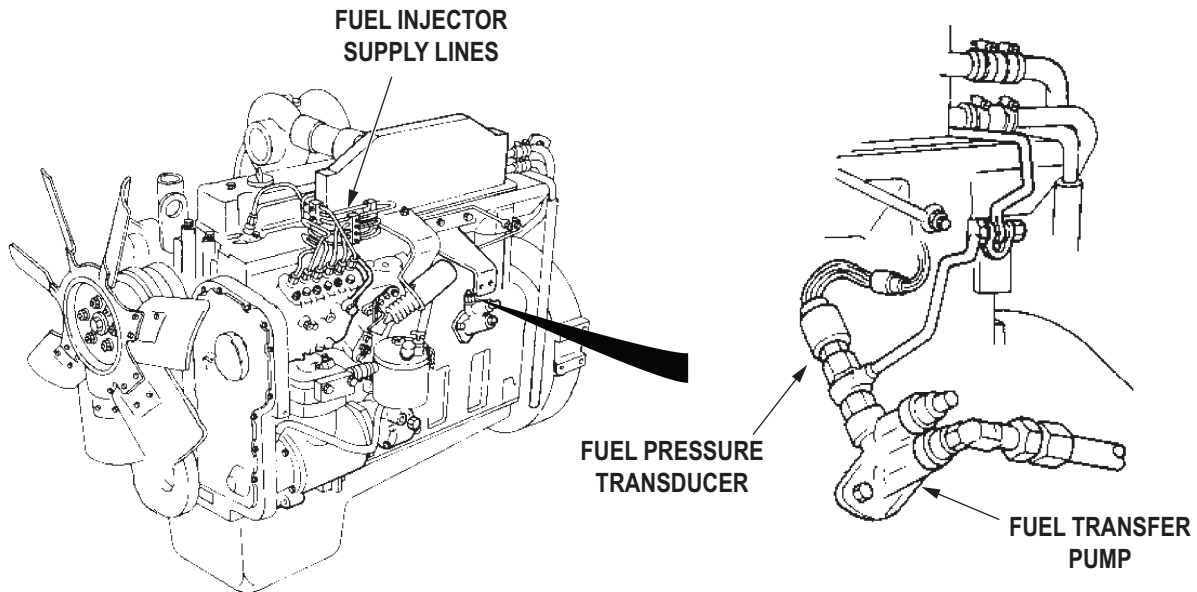

T0384DAA

Figure 11. Fuel Injector Supply Line.

CONDITION/INDICATION

IS FUEL INJECTOR SUPPLY LINE CLOGGED?

DECISION

YES - Clear all clogged fuel injector supply lines with compressed air or sturdy wire. Go to Step (14) to verify problem is solved.

NO - Go to Step (12).

POOR ACCELERATION AND/OR LACK OF POWER - Continued**STEP****12. IS FUEL FILTER DIRTY OR CLOGGED?**

Remove fuel filter (Volume 2, WP 0258) and check for a dirty filter or clogged.

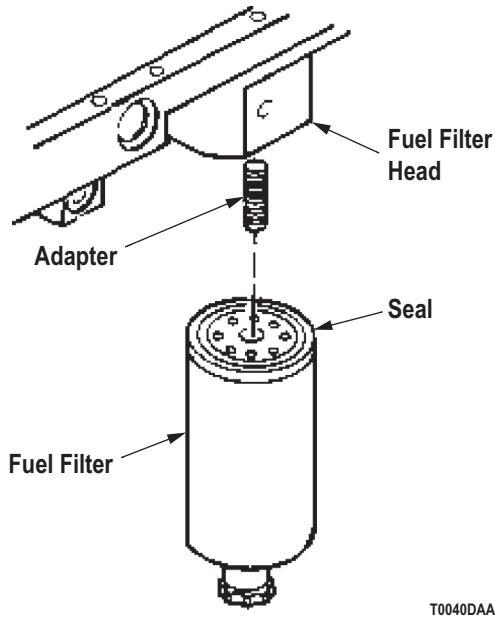

T0040DAA

Figure 12. Fuel Filter.

CONDITION/INDICATION

IS FUEL FILTER DIRTY OR CLOGGED?

DECISION

YES - Replace fuel filter (Volume 2, WP 0258). Go to Step (14) to verify problem is solved.
NO - Go to Step (13).

POOR ACCELERATION AND/OR LACK OF POWER - Continued**STEP****13. DOES TURBOCHARGER OPERATE PROPERLY?**

- a. Remove air intake tube from turbocharger inlet (Volume 2, WP 0249).

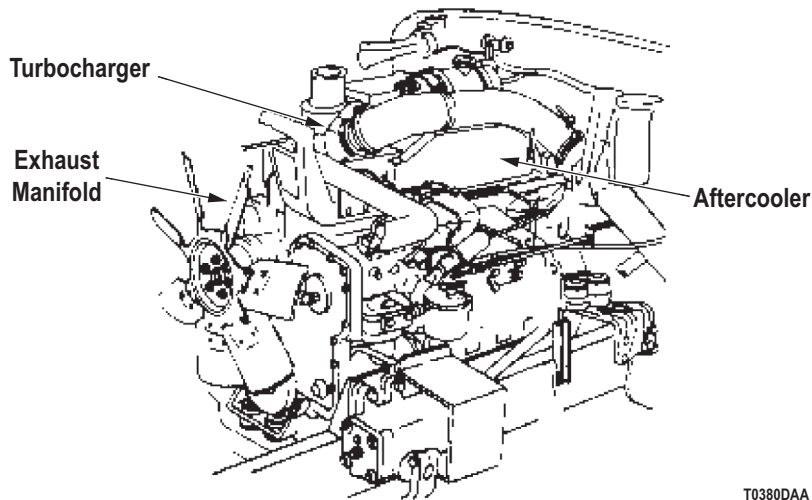

Figure 13. Turbocharger.

WARNING

Turbocharger intake fans are extremely sharp and turn at very high RPMs. Keep hands and loose items away from intake opening. Failure to do so may cause injury to personnel.

- b. Start engine (TM 9-2320-272-10).
- c. Check if turbo fan rotates freely.

CONDITION/INDICATION

DOES TURBOCHARGER OPERATE PROPERLY?

DECISION

YES - Notify supervisor. It is possible that another troubleshooting work package applies.

NO - Replace turbocharger (Volume 2, WP 0249). Go to Step (14) to verify problem is solved.

POOR ACCELERATION AND/OR LACK OF POWER - Continued**STEP**

14. IS YOUR ORIGINAL PROBLEM STILL PRESENT?
- a. Ensure vehicle is returned to normal operating condition.
 - b. Check to see if your original problem still exists.

CONDITION/INDICATION

IS YOUR ORIGINAL PROBLEM STILL PRESENT?

DECISION

YES - Notify supervisor.
NO - Problem fixed.

END OF WORK PACKAGE

**FIELD MAINTENANCE
ENGINE SURGES**

INITIAL SETUP:**Tools and Special Tools**

Tool Kit, General Mechanic's: Automotive
(Volume 5, WP 0826, Table 1, Item 56)

Personnel Required

(2)

References

Point to Point Schematics

References (cont.)

Volume 2, WP 0254
Volume 2, WP 0268
Volume 2, WP 0269
Volume 3, WP 0365

Equipment Condition

Vehicle parked and engine shut down.
(TM 9-2320-272-10)

TROUBLESHOOTING PROCEDURE**ENGINE SURGES****NOTE**

Conduct these malfunction tests if engine speed is unstable or engine surges at all speeds. This procedure will check fuel lines for leaks, obstructions, or damage and throttle linkage and modulator cable for proper operation and adjustment.

ENGINE SURGES - Continued**STEP**

1. ARE FUEL LINES IN GOOD OPERATING CONDITION?
 - a. Visually inspect fuel lines.

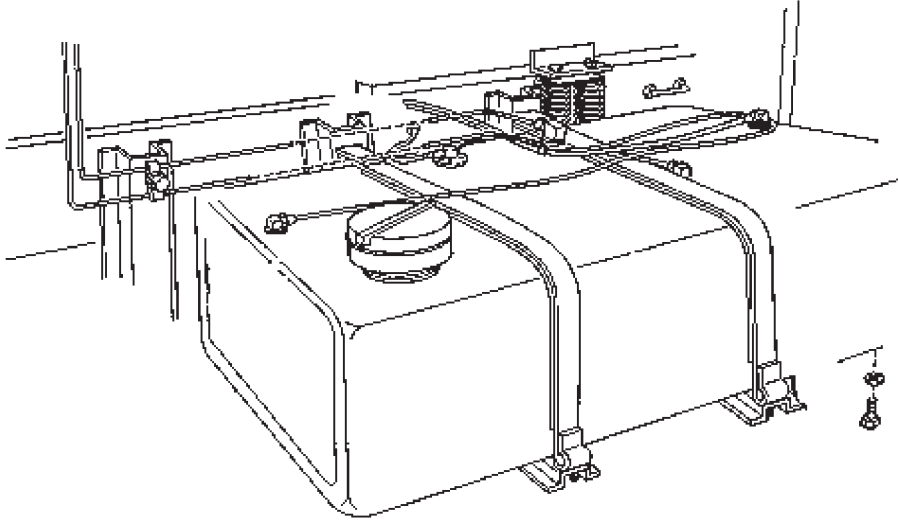

T1033DAA

Figure 1. Fuel Tank.

- b. Check fuel lines and connections for leaks, obstruction, and damage.
 - c. Tighten connections where leaks are detected.

CONDITION/INDICATION

ARE FUEL LINES IN GOOD OPERATING CONDITION?

DECISION

YES - Go to Step (2).

NO - Replace defective fuel lines (Volume 2, WP 0254). Go to Step (4) to verify problem is solved.

ENGINE SURGES - Continued**STEP**

2. IS MODULATOR CABLE IN GOOD CONDITION?
 - a. Check modulator cable for proper operation.

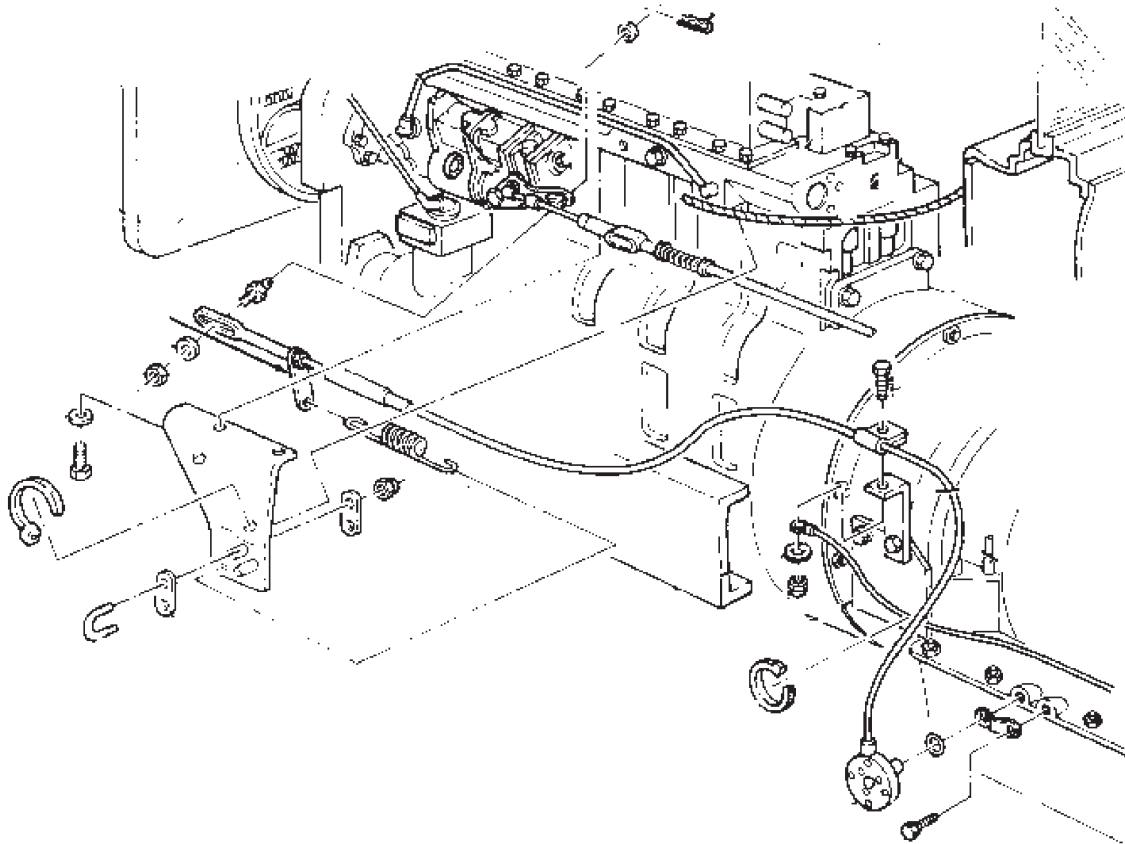

T0395DAA

Figure 2. Modulator Cable.

- b. Check if modulator cable operates properly.

CONDITION/INDICATION

IS MODULATOR CABLE IN GOOD CONDITION?

DECISION

YES - Go to Step (3).

NO - Replace modulator cable (Volume 3, WP 0365). Go to Step (4) to verify problem is solved.

ENGINE SURGES - Continued**STEP****3. IS THROTTLE LINKAGE ADJUSTED AND OPERATING PROPERLY?**

Visually check throttle linkage for proper operation and adjustment.

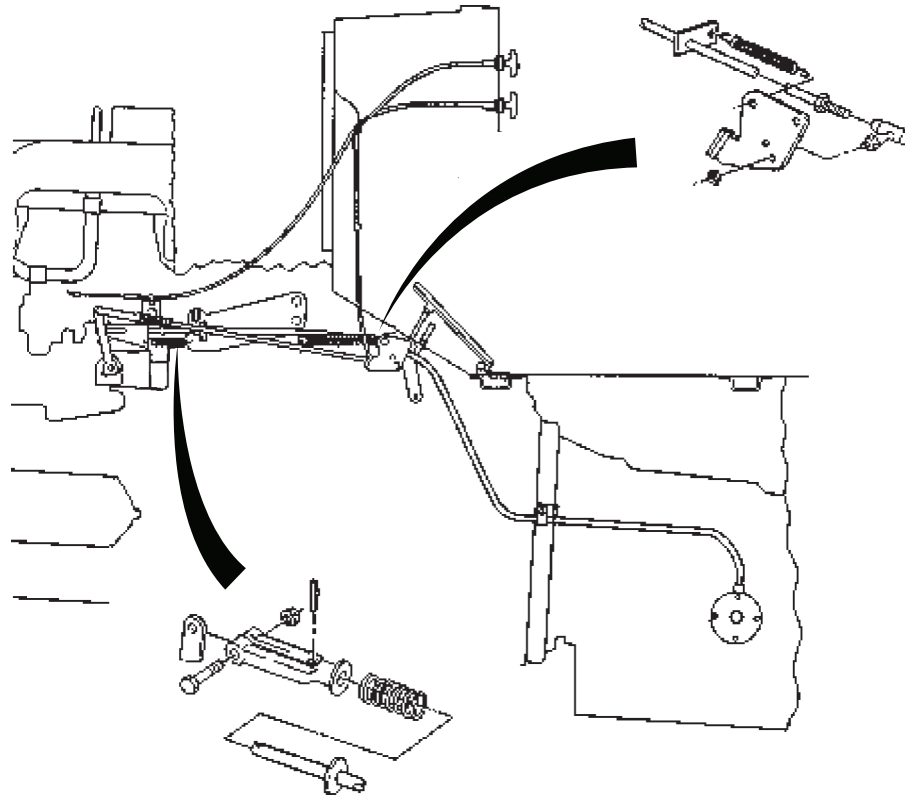

T1034DAA

Figure 3. Throttle Linkage.

CONDITION/INDICATION

IS THROTTLE LINKAGE ADJUSTED AND OPERATING PROPERLY?

DECISION

YES - Notify supervisor. It possible that another troubleshooting work package applies.

NO - Clean, adjust, or repair as necessary M939/A1 (Volume 2, WP 0268), M939A2 (Volume 2, WP 0269). Go to Step (4) to verify problem is solved.

ENGINE SURGES - Continued**STEP**

4. IS YOUR ORIGINAL PROBLEM STILL PRESENT?
 - a. Ensure vehicle is returned to normal operating condition.
 - b. Check to see if your original problem still exists.

CONDITION/INDICATION

IS YOUR ORIGINAL PROBLEM STILL PRESENT?

DECISION

YES - Notify supervisor.
NO - Problem fixed.

END OF WORK PACKAGE

**FIELD MAINTENANCE
EXCESSIVE OIL CONSUMPTION**

INITIAL SETUP:**Tools and Special Tools**

Tool Kit, General Mechanic's: Automotive
(Volume 5, WP 0826, Table 1, Item 56)

Personnel Required

(2)

References

Point to Point Schematics

References (cont.)

Volume 2, WP 0222
Volume 2, WP 0231
Volume 2, WP 0232
Volume 2, WP 0249

Equipment Condition

Vehicle parked and engine shut down.
(TM 9-2320-272-10)

TROUBLESHOOTING PROCEDURE**EXCESSIVE OIL CONSUMPTION****NOTE**

Conduct this malfunction test if there is excessive engine oil consumption. This procedure will check for excessive oil in engine, and engine oil leaks.

EXCESSIVE OIL CONSUMPTION - Continued**STEP****1. IS ENGINE OIL LEVEL TOO HIGH?**

- a. Check dipstick for excessive oil (Volume 2, WP 0232).

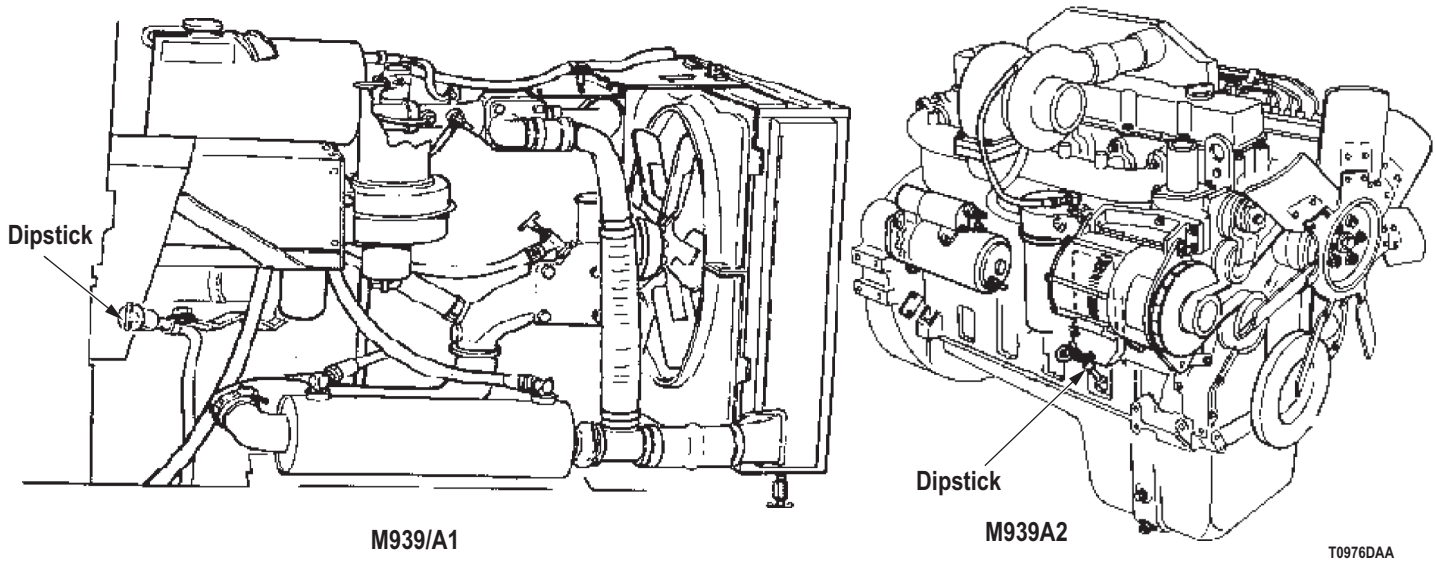

Figure 1. Oil Dipstick.

- b. If there is excessive oil in engine, drain crankcase to safe operating level.

CONDITION/INDICATION

IS ENGINE OIL LEVEL TOO HIGH?

DECISION

- YES - Go to Step (4) to verify problem is solved.
 NO - Go to Step (2).

EXCESSIVE OIL CONSUMPTION - Continued**STEP****2. IS OIL LEAKING FROM ENGINE?**

- a. Wipe off edges of rocker arm cover, oil pan, screws, oil filters and other external engine surfaces.

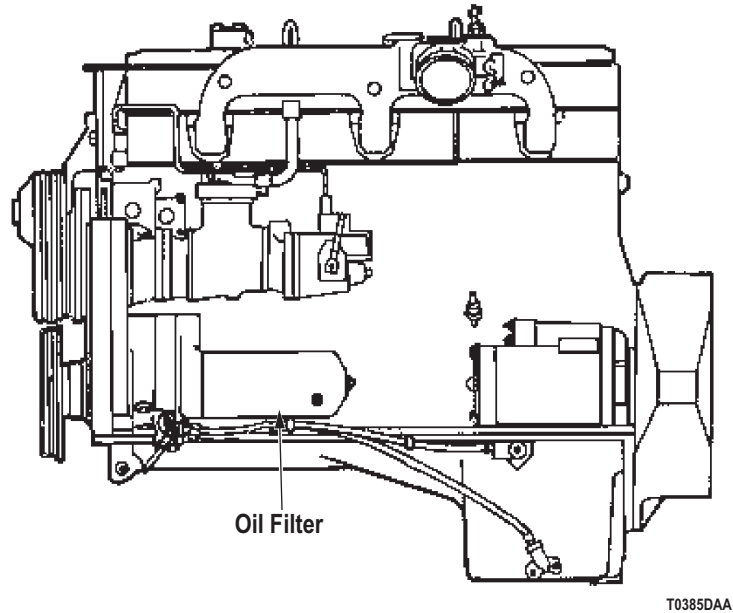

Figure 2. Engine.

- b. Start engine and observe for leaks.
- c. If an oil leak is seen, tighten nuts, screws, and oil filters as needed, and again observe for leaks.

CONDITION/INDICATION

IS OIL LEAKING FROM ENGINE?

DECISION

YES - Rocker arm cover(s) leak. Replace leaking gasket(s) M939A2 (Volume 2, WP 0222). Go to Step (4) to verify problem is solved.
 YES - Oil pan is leaking. Replace oil pan gasket M939/A1 (Volume 2, WP 0231), M939A2 (Volume 2, WP 0230). Go to Step (4) to verify problem is solved.
 YES - Oil filter is leaking. Replace oil filter (Volume 2, WP 0232). Go to Step (4) to verify problem is solved.
 NO - Go to Step (3).

EXCESSIVE OIL CONSUMPTION - Continued

STEP

3. IS TURBOCHARGER LEAKING OIL INTO AIR INTAKE OR EXHAUST?
 - a. Remove air intake tube from turbocharger inlet (Volume 2, WP 0249).

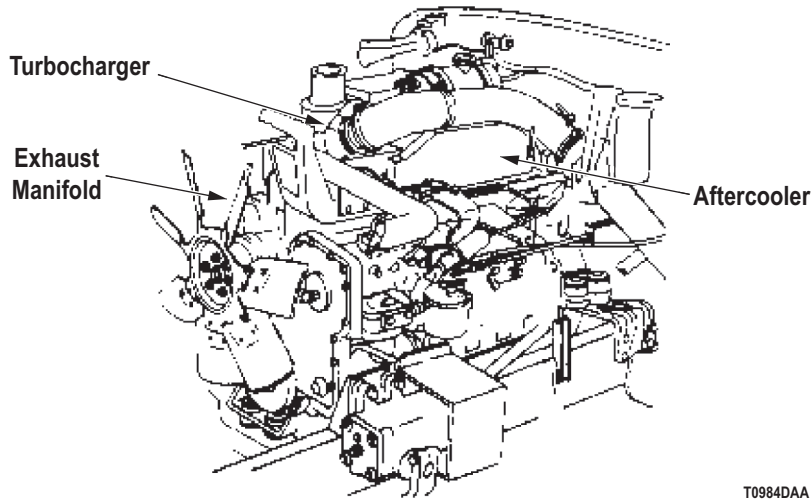

T0984DAA

Figure 3. Turbocharger.

- b. Check turbocharger for leaking oil into air intake or exhaust.

CONDITION/INDICATION

IS TURBOCHARGER LEAKING OIL INTO AIR INTAKE OR EXHAUST?

DECISION

YES - Replace turbocharger (Volume 2, WP 0249). Go to Step (4) to verify problem is solved.
 NO - Notify supervisor. It is possible that another troubleshooting work package applies.

STEP

4. IS YOUR ORIGINAL PROBLEM STILL PRESENT?
 - a. Ensure vehicle is returned to normal operating condition.
 - b. Check to see if your original problem still exists.

CONDITION/INDICATION

IS YOUR ORIGINAL PROBLEM STILL PRESENT?

DECISION

YES - Notify supervisor.
 NO - Problem fixed.

END OF WORK PACKAGE

FIELD MAINTENANCE
LOW OIL PRESSURE

INITIAL SETUP:**Tools and Special Tools**

Tool Kit, General Mechanic's: Automotive
(Volume 5, WP 0826, Table 1, Item 56)

Personnel Required

(2)

References

Point to Point Schematics
WP 0103
Volume 2, WP 0224

References (cont.)

Volume 2, WP 0225
Volume 2, WP 0226
Volume 2, WP 0230
Volume 2, WP 0232
Volume 2, WP 0333

Equipment Condition

Vehicle parked and engine shut down.
(TM 9-2320-272-10)

TROUBLESHOOTING PROCEDURE**LOW OIL PRESSURE****NOTE**

Conduct these malfunction tests if engine oil pressure is low. This procedure will check oil lines for good condition, oil filter for leaks and engine oil pressure.

LOW OIL PRESSURE - Continued**STEP****1. ARE OIL SUPPLY LINES IN GOOD CONDITION?**

- a. Visually inspect oil supply lines for cracks, splits, leaks, and damage.

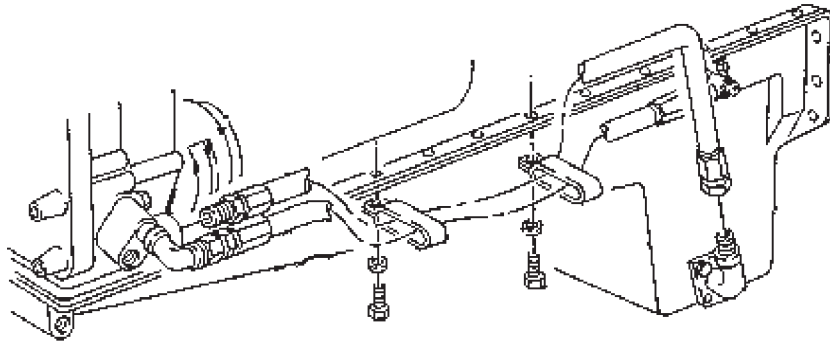

T0062DAA

Figure 1. Engine Oil Lines.

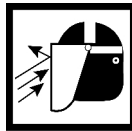
WARNING

Eyeshields must be worn when cleaning with compressed air. Compressed air source will not exceed 30 psi (207 kPa). Failure to comply may result in injury or death to personnel.

- b. Clear clogged or obstructed lines with compressed air or sturdy wire.

CONDITION/INDICATION

ARE OIL SUPPLY LINES IN GOOD CONDITION?

DECISION

YES - Go to Step (2).

NO - Oil pick up hose is damaged. Replace damaged hose (Volume 2, WP 0224). Go to Step (4) to verify problem is solved.

NO - Oil pump return hose is damaged. Replace oil pump return hose (Volume 2, WP 0225). Go to Step (4) to verify problem is solved.

NO - Front sump tube is damaged. Replace front sump tube M939/A1 (Volume 2, WP 0226), M939A2. (Volume 2, WP 0230) Go to Step (4) to verify problem is solved.

LOW OIL PRESSURE - Continued**STEP****2. DOES OIL FILTER LEAK?**

Visually inspect oil filter for leaks.

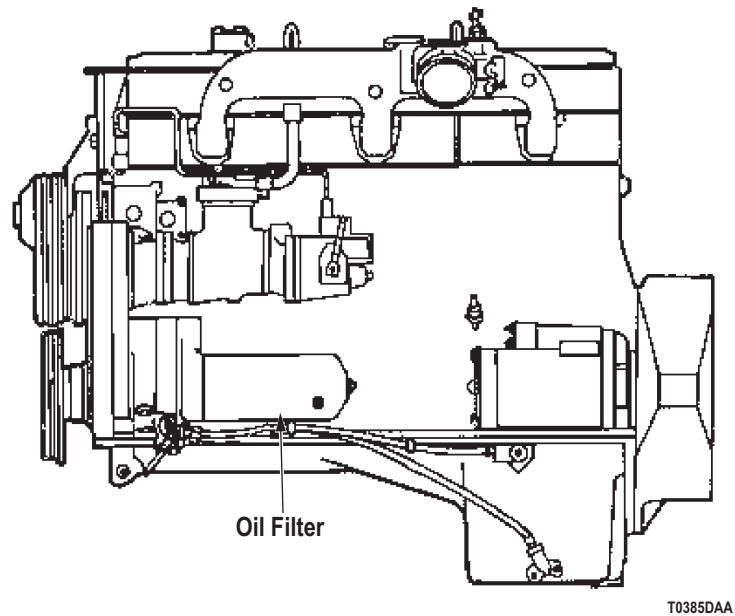

Figure 2. Oil Filter.

CONDITION/INDICATION

DOES OIL FILTER LEAK?

DECISION

YES - Perform oil filter maintenance (Volume 2, WP 0232). Go to Step (4) to verify problem is solved.
NO - Go to Step (3).

LOW OIL PRESSURE - Continued**STEP**

3. IS OIL PRESSURE WITHIN LIMITS 55-75 psi (379-571 kPa)?
 - a. Stop vehicle engine.
 - b. Make sure engine oil level is correct.

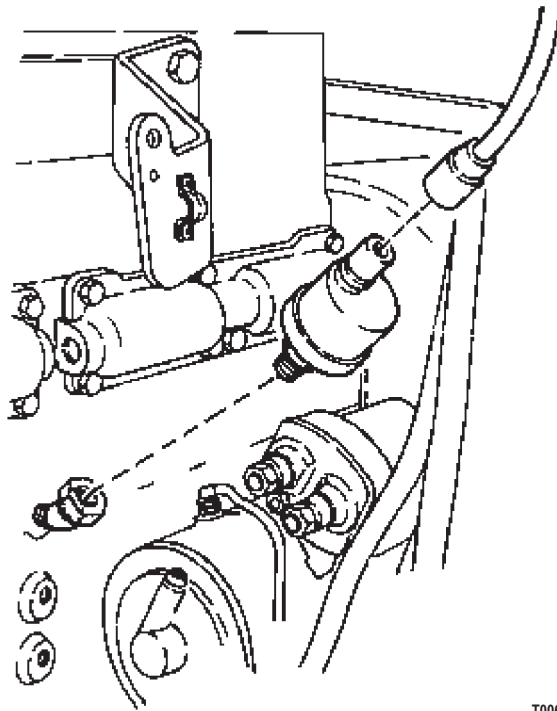

T0061DAA

Figure 3. Engine Oil Pressure Sending Unit.

- c. Remove oil pressure sending unit (Volume 2, WP 0333).
- d. Install pressure gauge.
- e. Start engine and hold vehicle engine speed at 2100 RPM.
- f. Oil pressure gauge should read between 55-75 psi (379-571 kPa).
- g. Shut off engine.
- h. Remove pressure gauge.
- i. Install oil pressure sending unit.

CONDITION/INDICATION

IS OIL PRESSURE WITHIN LIMITS 55-75 psi (379-571 kPa)?

DECISION

- NO - Notify supervisor. It is possible that another troubleshooting work package applies.
YES - Perform Oil Pressure Gauge Inoperative troubleshooting (WP 0103).

LOW OIL PRESSURE - Continued**STEP**

4. IS YOUR ORIGINAL OIL PRESSURE PROBLEM STILL PRESENT?
 - a. Ensure vehicle is returned to normal operating condition.
 - b. Check to see if your original oil pressure problem still exists.

CONDITION/INDICATION

IS YOUR ORIGINAL OIL PRESSURE PROBLEM STILL PRESENT?

DECISION

YES - Notify supervisor.
NO - Problem fixed.

END OF WORK PACKAGE

**FIELD MAINTENANCE
ENGINE OIL CONTAMINATED**

INITIAL SETUP:**Tools and Special Tools**

Tool Kit, General Mechanic's: Automotive
(Volume 5, WP 0826, Table 1, Item 56)

Personnel Required

(2)

References

Point to Point Schematics
Volume 2, WP 0211
Volume 2, WP 0213

References (cont.)

Volume 2, WP 0229
Volume 2, WP 0232
Volume 2, WP 0233
Volume 2, WP 0243
Volume 2, WP 0299

Equipment Condition

Vehicle parked and engine shut down.
(TM 9-2320-272-10)

TROUBLESHOOTING PROCEDURE**ENGINE OIL CONTAMINATED****NOTE**

Conduct this malfunction test if engine oil is contaminated. This procedure will check for sludge and metal particle in oil. It also checks for leaking transfer pump seal, transfer pump gasket, oil cooler and aftercooler.

ENGINE OIL CONTAMINATED - Continued**STEP****1. DOES OIL SAMPLE TEST INDICATE OIL IS CONTAMINATED?**

Take oil sample to determine type of contamination.

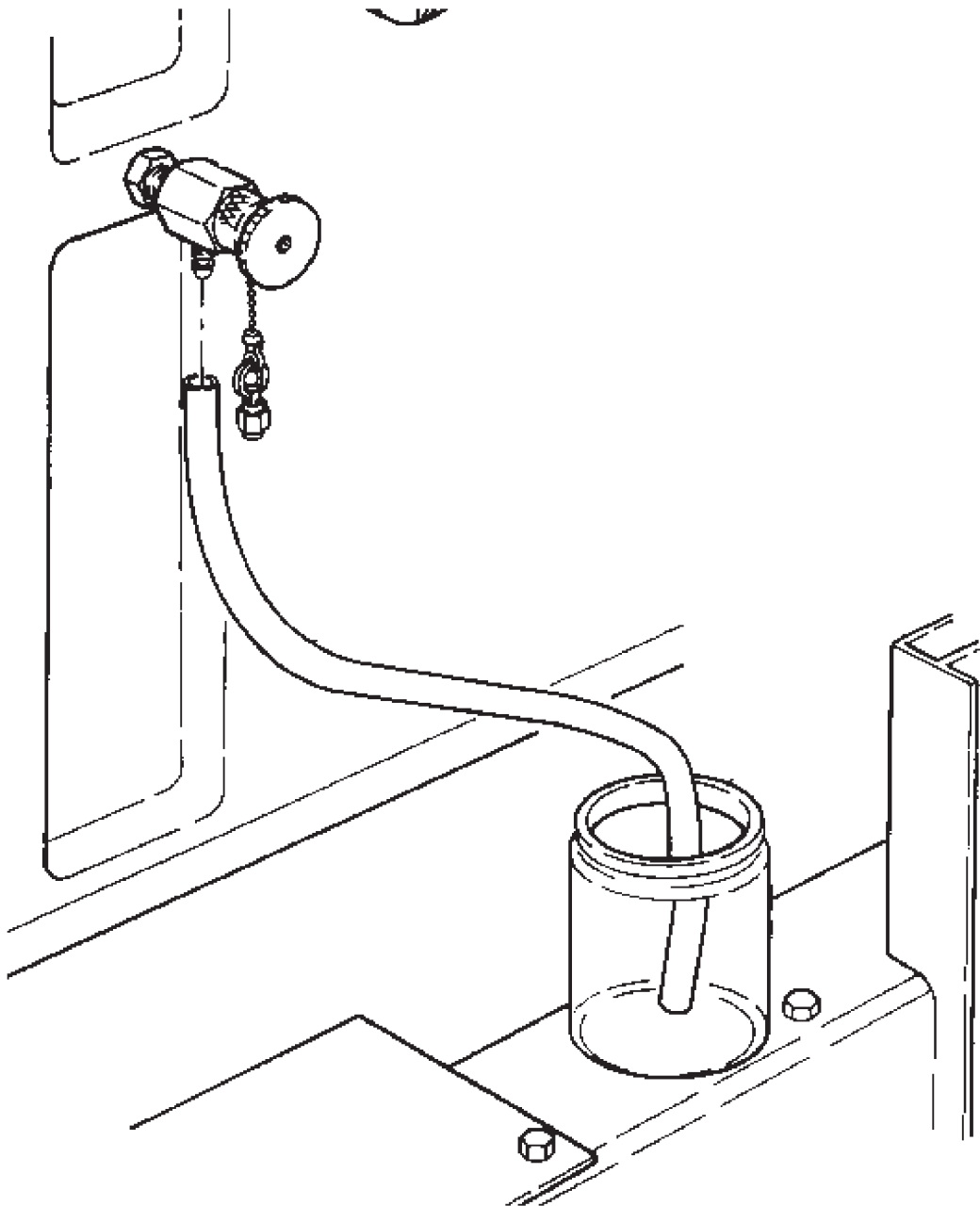

T0387DAA

Figure 1. Oil Sample.

ENGINE OIL CONTAMINATED - Continued**CONDITION/INDICATION**

DOES OIL SAMPLE TEST INDICATE OIL IS CONTAMINATED?

DECISION

YES - Excessive sludge in oil. Go to Step (4) to verify problem is solved.

YES - Oil is thin and black. Go to Step (2) (M939A2). Notify supervisor. It is possible that another troubleshooting work package applies (M939/A1).

YES - Oil has a milky color, coolant is present in oil. Go to Step (3).

YES - Metal particles present in oil. Notify Supervisor. Action may not be possible at this level of maintenance.

NO - Notify Supervisor. It is possible that another troubleshooting work package applies.

STEP**2. DOES THE TRANSFER PUMP LEAK OIL?**

Check transfer pump seal and transfer pump mounting gasket for leaks.

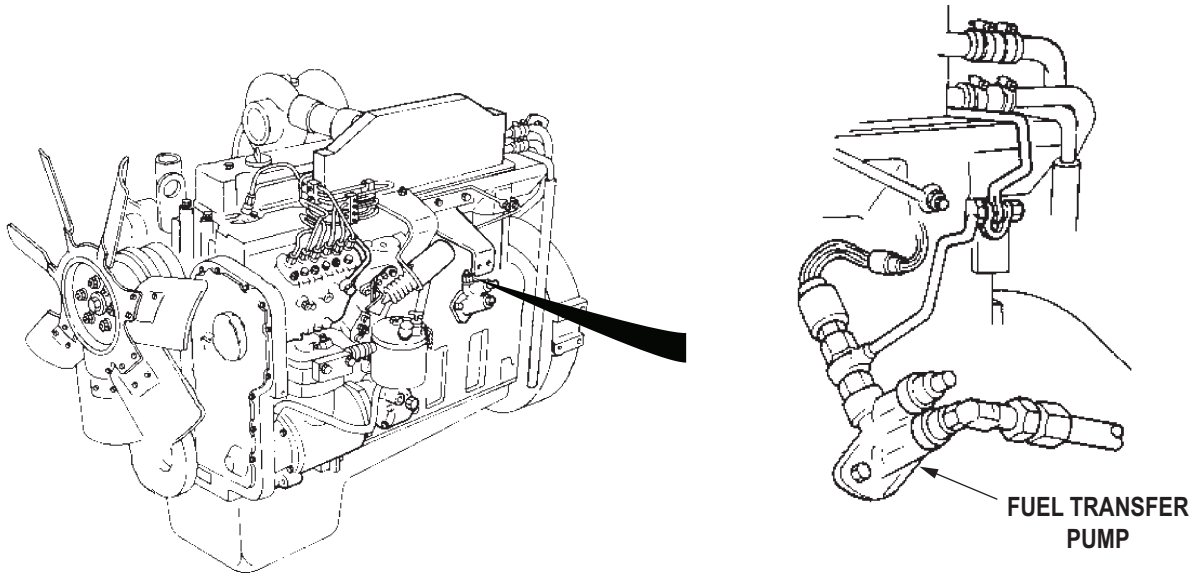

T1111DAA

Figure 2. Fuel Transfer Pump.

CONDITION/INDICATION

DOES THE TRANSFER PUMP LEAK OIL?

DECISION

YES - Replace transfer pump and/or gasket (Volume 2, WP 0243). Go to Step (4) to verify problem is solved.

NO - Notify supervisor. It is possible that another troubleshooting work package applies.

ENGINE OIL CONTAMINATED - Continued**STEP****3. DO OIL COOLER OR AFTERCOOLER LEAK?**

- a. Inspect oil cooler for leaks M939/A1 (Volume 2, WP 0233), M939A2 (Volume 2, WP 0229).

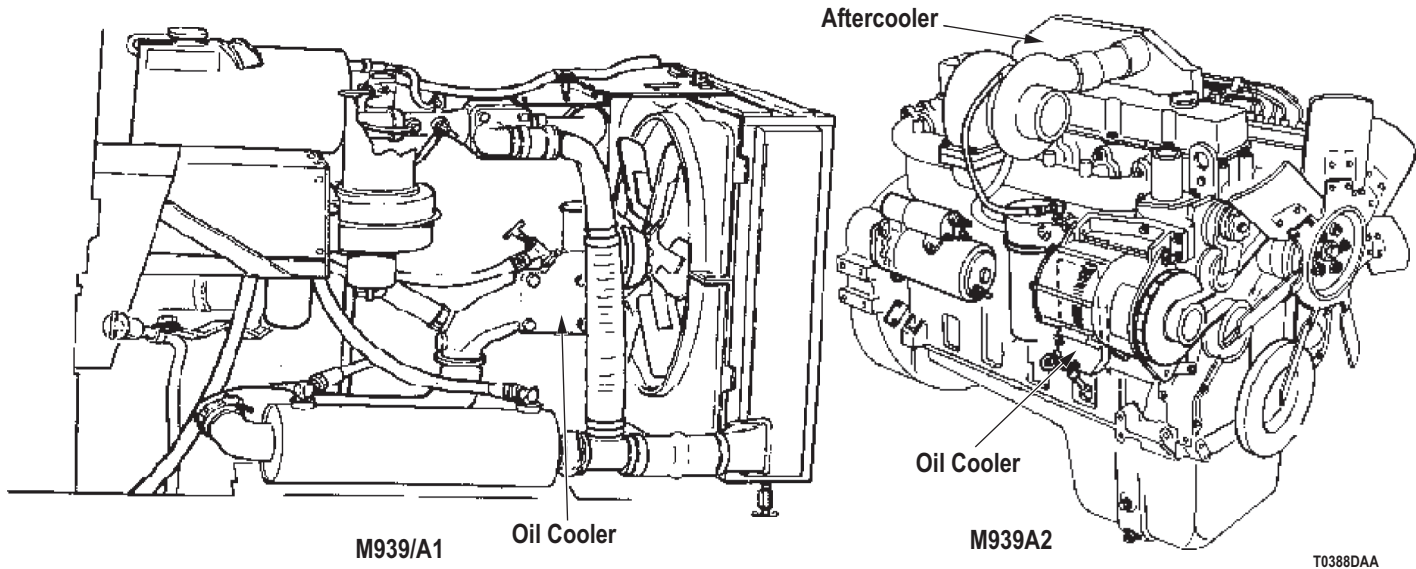

Figure 3. Engine Oil Cooler and Aftercooler.

- b. Inspect aftercooler for leaks.

NOTE

During engine operation, oil pressure will be higher than coolant pressure. A leak in oil cooler will show oil in coolant. After engine is shut down, residual pressure in cooling system will cause coolant to leak into oil.

- c. After engine has cooled off, check oil dipstick for evidence of coolant and surge tank for evidence of oil.

CONDITION/INDICATION

DO OIL COOLER OR AFTERCOOLER LEAK?

DECISION

YES - Oil cooler leaks. Replace oil cooler M939/A1 (Volume 2, WP 0233), M939A2 (Volume 2, WP 0229). Go to Step (4) to verify problem is solved.

YES - Aftercooler leaks. Replace aftercooler (M939A2 only) (Volume 2, WP 0299). Go to Step (4) to verify problem is solved.

NO - Replace engine M939/A1 (Volume 2, WP 0211), M939A2 (Volume 2, WP 0213). Go to Step (4) to verify problem is solved.

ENGINE OIL CONTAMINATED - Continued**STEP**

4. IS YOUR ORIGINAL PROBLEM STILL PRESENT?
 - a. Ensure vehicle is returned to normal operating condition.
 - b. Drain and refill engine oil (Volume 2, WP 0232).
 - c. Check to see if your original problem still exists.

CONDITION/INDICATION

IS YOUR ORIGINAL PROBLEM STILL PRESENT?

DECISION

YES - Notify supervisor.
NO - Problem fixed.

END OF WORK PACKAGE

**FIELD MAINTENANCE
EXCESSIVE VIBRATION OR CLUNKING**

INITIAL SETUP:**Tools and Special Tools**

Tool Kit, General Mechanic's: Automotive
(Volume 5, WP 0826, Table 1, Item 56)

References (cont.)

Volume 2, WP 0216
Volume 2, WP 0218
Volume 2, WP 0219

Personnel Required

(2)

Equipment Condition

Vehicle parked and engine shut down.
(TM 9-2320-272-10)

References

Point to Point Schematics

TROUBLESHOOTING PROCEDURE**EXCESSIVE VIBRATION OR CLUNKING****NOTE**

Conduct this malfunction test if engine excessive vibration or clunking. This procedure will check for loose or damaged motor mounts and loose vibration damper.

STEP

1. ARE ENGINE MOUNTING BRACKETS AND PADS LOOSE OR DAMAGED?

Check engine mounting brackets and pads for looseness or damage.

CONDITION/INDICATION

ARE ENGINE MOUNTING BRACKETS AND PADS LOOSE OR DAMAGED?

DECISION

YES - Replace or tighten loose or damaged mounting brackets and pads (Volume 2, WP 0216). Go to Step (3) to verify problem is solved.

NO - Go to Step (2).

EXCESSIVE VIBRATION OR CLUNKING - Continued**STEP**

2. IS VIBRATION DAMPER LOOSE?

Check if vibration damper is loose.

CONDITION/INDICATION

IS VIBRATION DAMPER LOOSE?

DECISION

YES - Replace loose vibration damper M939/A1 (Volume 2, WP 0218), M939A2 (Volume 2, WP 0219). Go to Step (3) to verify problem is solved.

NO - Notify supervisor. It is possible that another troubleshooting work package applies.

STEP

3. IS YOUR ORIGINAL PROBLEM STILL PRESENT?

- a. Ensure vehicle is returned to normal operating condition.
- b. Check to see if your original problem still exists.

CONDITION/INDICATION

IS YOUR ORIGINAL PROBLEM STILL PRESENT?

DECISION

YES - Notify supervisor.

NO - Problem fixed.

END OF WORK PACKAGE

FIELD MAINTENANCE EXCESSIVE FUEL CONSUMPTION

INITIAL SETUP:

Tools and Special Tools

Tool Kit, General Mechanic's: Automotive
(Volume 5, WP 0826, Table 1, Item 56)

References (cont.)

TM 9-2320-272-10
Volume 2, WP 0254

Personnel Required

(2)

Equipment Condition

Vehicle parked and engine shut down.
(TM 9-2320-272-10)

References

Point to Point Schematics

TROUBLESHOOTING PROCEDURE

EXCESSIVE FUEL CONSUMPTION

NOTE

Conduct these malfunction tests if fuel consumption is excessive. This procedure will check air intake stack and air cleaner element for restrictions and fuel lines for leaks or damage.

STEP

1. IS AIR RESTRICTION INDICATOR IN RED ZONE?
 - a. Check air cleaner indicator for air restriction indication.

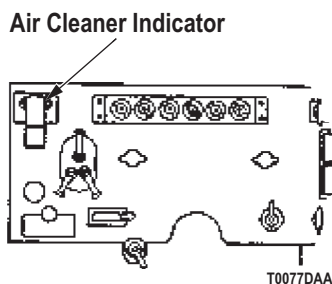

Figure 1. Air Cleaner Indicator.

- b. Inspect air intake stack for restriction.

CONDITION/INDICATION

IS AIR RESTRICTION INDICATOR IN RED ZONE?

DECISION

YES - Perform air cleaner servicing (TM 9-2320-272-10). Go to Step (3) to verify problem is solved.
NO - Go to Step (2).

EXCESSIVE FUEL CONSUMPTION - Continued**STEP****2. ARE FUEL LINES IN GOOD CONDITION?**

Visually inspect fuel lines, hoses, fuel return lines and connections for leaks, bends, kinks, and damage.

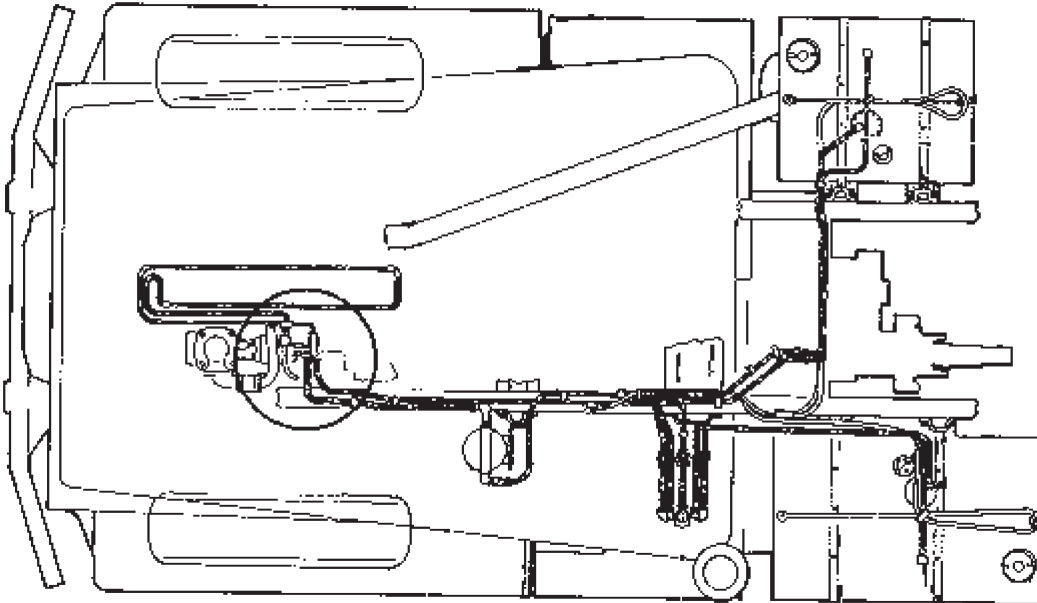

T0078DAA

Figure 2. Fuel System.

CONDITION/INDICATION

ARE FUEL LINES IN GOOD CONDITION?

DECISION

YES - Go to Step (3) to verify problem is solved.

NO - Replace damaged fuel lines (Volume 2, WP 0254). Go to Step (3) to verify problem is solved.

EXCESSIVE FUEL CONSUMPTION - Continued**STEP**

3. IS YOUR ORIGINAL FUEL CONSUMPTION PROBLEM STILL PRESENT?
 - a. Ensure vehicle is returned to normal operating condition.
 - b. Check to see if your original fuel consumption problem still exists.

CONDITION/INDICATION

IS YOUR ORIGINAL FUEL CONSUMPTION PROBLEM STILL PRESENT?

DECISION

YES - Contact supervisor.
NO - Problem fixed.

END OF WORK PACKAGE

FIELD MAINTENANCE
ENGINE CRANKS BUT WILL NOT START IN COLD WEATHER (FUEL SYSTEM OPERATING PROPERLY)

INITIAL SETUP:**Tools and Special Tools**

Tool Kit, General Mechanic's: Automotive
(Volume 5, WP 0826, Table 1, Item 56)
Multimeter
(Volume 5, WP 0826, Table 1, Item 34)
Test Set, Electronic Systems
(Volume 5, WP 0826, Table 1, Item 51)

References (cont.)

Volume 2, WP 0263
Volume 2, WP 0264
Volume 2, WP 0265
Volume 2, WP 0307
Volume 2, WP 0337
Volume 3, WP 0352

Personnel Required

(2)

Equipment Condition

Vehicle parked and engine shut down.
(TM 9-2320-272-10)

References

Point to Point Schematics

TROUBLESHOOTING PROCEDURE**ENGINE CRANKS BUT WILL NOT START IN COLD WEATHER (FUEL SYSTEM OPERATING PROPERLY)****NOTE**

Conduct these malfunction tests if engine cranks but will not start with fuel available. This procedure will check for ether cylinder, ether start system electrical power source, defective ether start valve, clogged tubing, defective atomizer, faulty wiring or defective ether start switch.

ENGINE CRANKS BUT WILL NOT START IN COLD WEATHER (FUEL SYSTEM OPERATING PROPERLY) - Continued

STEP

1. IS ETHER CYLINDER EMPTY?

- a. Check ether cylinder for ether level.

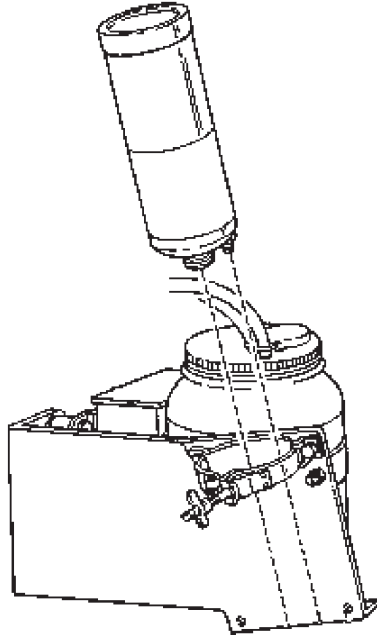

T0476DAA

Figure 1. Ether Cylinder.

- b. Remove ether cylinder from ether valve (Volume 2, WP 0263).
- c. Shake cylinder and listen for liquid splashing inside cylinder.

CONDITION/INDICATION

IS ETHER CYLINDER EMPTY?

DECISION

YES - Replace empty ether cylinder (Volume 2, WP 0263). Go to Step (10) to verify problem is solved.
NO - Reinstall ether cylinder, go to Step (2).

STEP

2. DOES ETHER VALVE OPERATE PROPERLY?

- a. Check for battery voltage at ether valve. Refer to point to point schematics.
- b. Disconnect circuit 570 wire at ether valve.

ENGINE CRANKS BUT WILL NOT START IN COLD WEATHER (FUEL SYSTEM OPERATING PROPERLY) - Continued

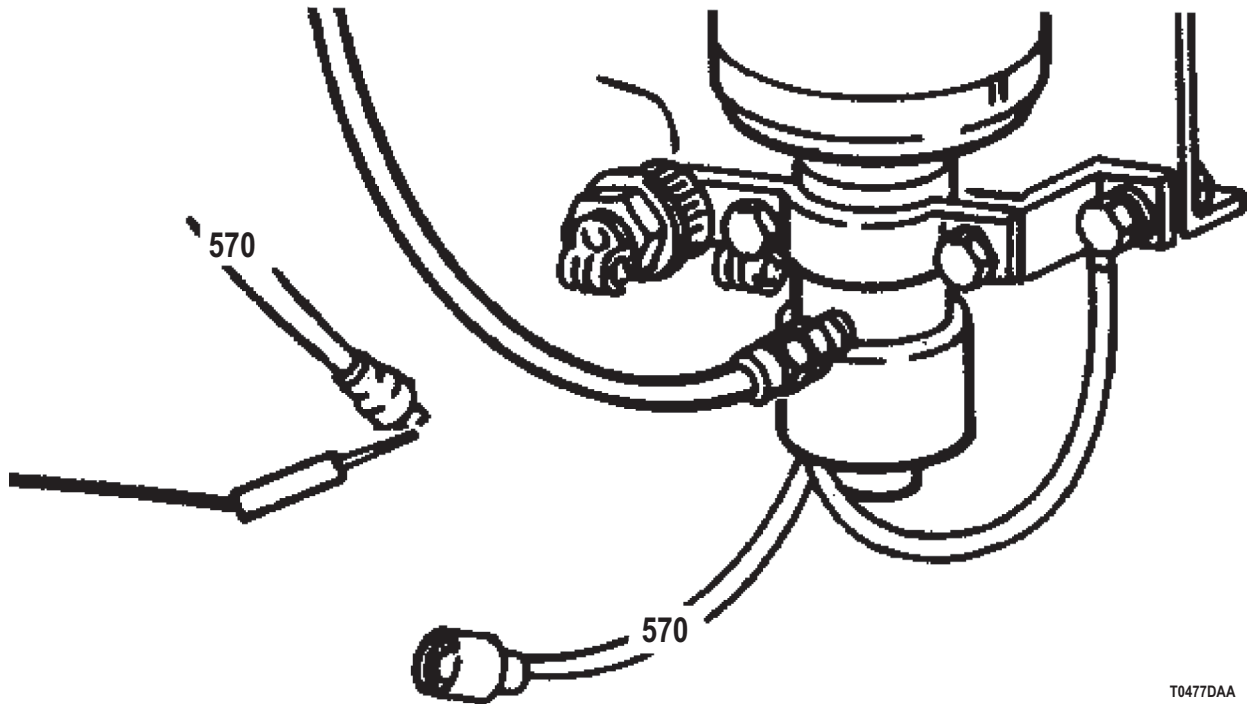

T0477DAA

Figure 2. Ether Valve.

- c. Set multimeter to VDC.
- d. Turn battery switch to ON position.
- e. Connect red lead to disconnected circuit 570 wire.
- f. Connect black lead to good ground.
- g. Multimeter will display volts DC.
- h. Crank engine and depress ether start switch.

NOTE

If battery voltage is present, ether valve is not operating properly.

- i. Meter reading should be greater than 18 VDC.

CONDITION/INDICATION

DOES ETHER VALVE OPERATE PROPERLY?

DECISION

- YES - Go to Step (3).
 NO - Go to Step (7).

ENGINE CRANKS BUT WILL NOT START IN COLD WEATHER (FUEL SYSTEM OPERATING PROPERLY) - Continued

STEP

3. DOES CIRCUIT 570 WIRE CONDUCT BATTERY VOLTAGE TO ETHER VALVE?
 - a. Check for battery voltage at fuel pressure switch terminal. Refer to point to point schematics.
 - b. Disconnect circuit 570 wire at ether cylinder valve from fuel pressure switch.

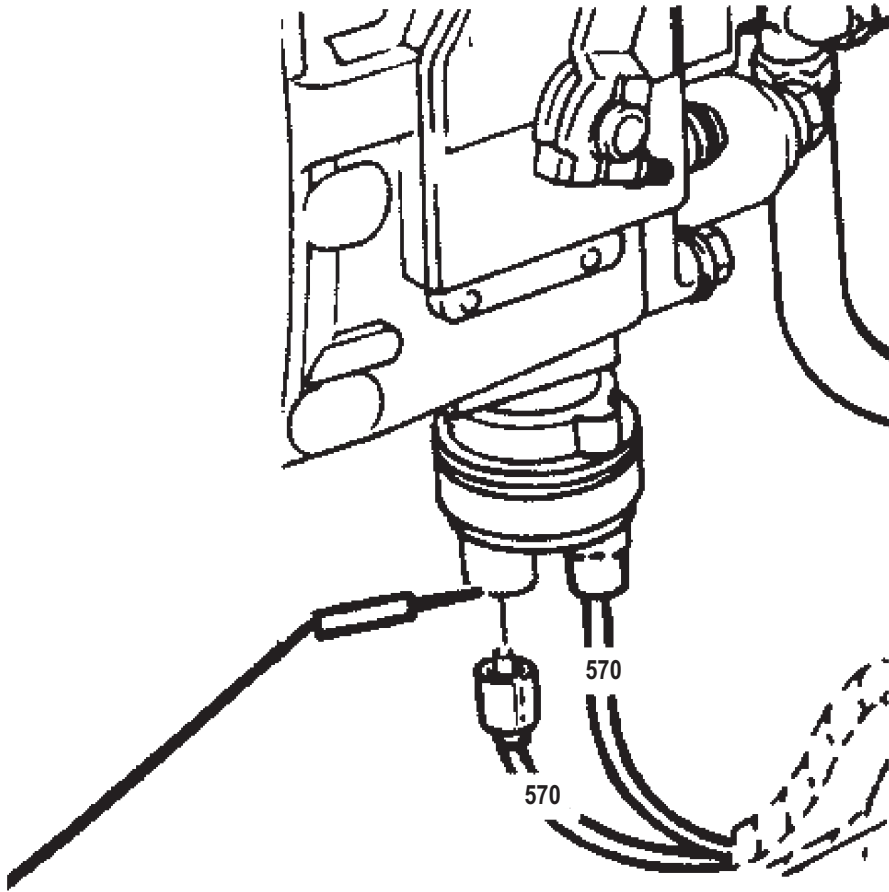

T0478DAA

Figure 3. Ether Valve Circuit 570 Wire.

ENGINE CRANKS BUT WILL NOT START IN COLD WEATHER (FUEL SYSTEM OPERATING PROPERLY) - Continued

- c. Connect red lead to circuit 570 terminal on fuel pressure switch.
- d. Connect black lead to good ground.
- e. Multimeter will display volts DC.
- f. Crank engine and depress ether start switch.

NOTE

If battery voltage is present, circuit 570 wire is faulty.

- g. Meter reading should be greater than 18 VDC.

CONDITION/INDICATION

DOES CIRCUIT 570 WIRE CONDUCT BATTERY VOLTAGE TO ETHER VALVE?

DECISION

YES - Go to Step (4).

NO - Repair circuit 570 wire to ether valve (Volume 3, WP 0352). Go to Step (10) to verify problem is solved.

ENGINE CRANKS BUT WILL NOT START IN COLD WEATHER (FUEL SYSTEM OPERATING PROPERLY) - Continued

STEP

4. DOES FUEL PRESSURE SWITCH OPERATE PROPERLY?

- a. Check for voltage at circuit 570 wire to ether start switch from fuel pressure switch. Refer to point to point schematics.
- b. Disconnect circuit 570 wire to ether start switch.

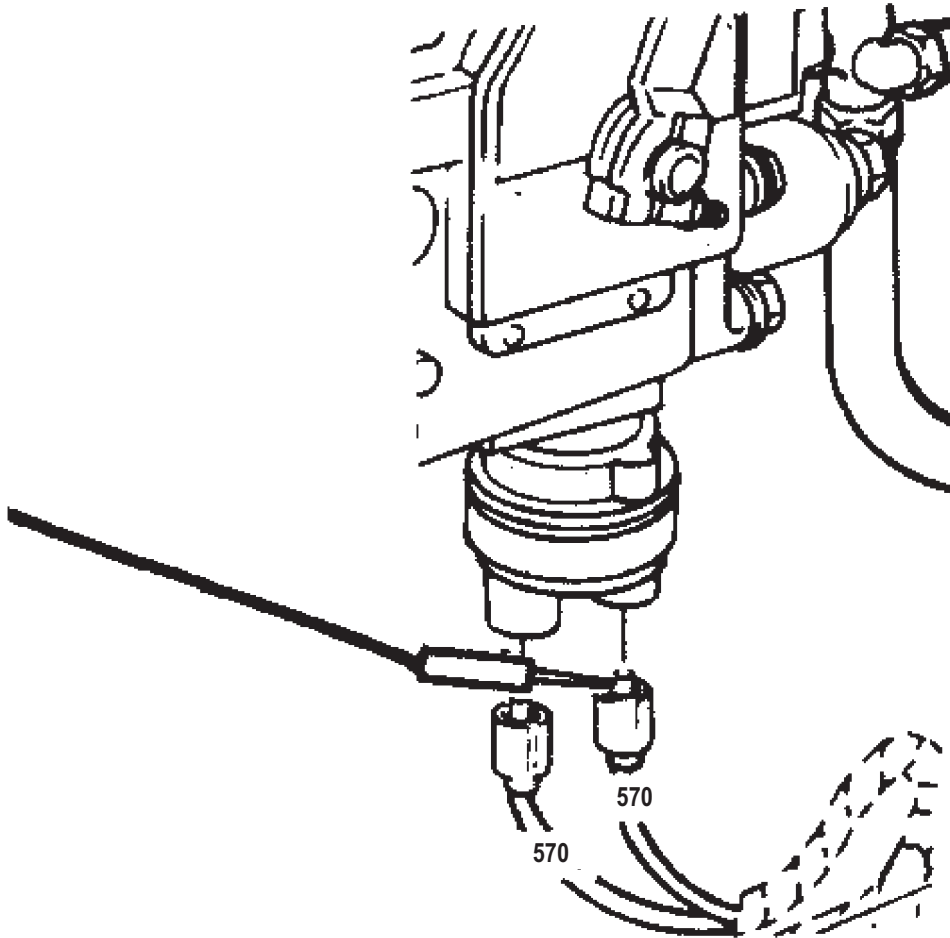

T0479DAA

Figure 4. Fuel Pressure Switch Circuit 570 Wire.

ENGINE CRANKS BUT WILL NOT START IN COLD WEATHER (FUEL SYSTEM OPERATING PROPERLY) - Continued

- c. Connect red lead to circuit 570 wire.
- d. Connect black lead to good ground.
- e. Multimeter will display volts DC.
- f. Crank engine and depress ether start switch.

NOTE

If battery voltage is present, fuel pressure switch is faulty.

- g. Meter reading should be greater than 18 VDC.

CONDITION/INDICATION

DOES FUEL PRESSURE SWITCH OPERATE PROPERLY?

DECISION

YES - Go to Step (5).

NO - Replace fuel pressure switch (Volume 2, WP 0337). Go to Step (10) to verify problem is solved.

ENGINE CRANKS BUT WILL NOT START IN COLD WEATHER (FUEL SYSTEM OPERATING PROPERLY) - Continued

STEP

5. DOES CIRCUIT 570 WIRE CONDUCT BATTERY VOLTAGE TO FUEL PRESSURE SWITCH?
 - a. Check for battery voltage at ether start switch connector. Refer to point to point schematics.
 - b. Disconnect circuit 570 wire to fuel pressure switch from ether start switch.

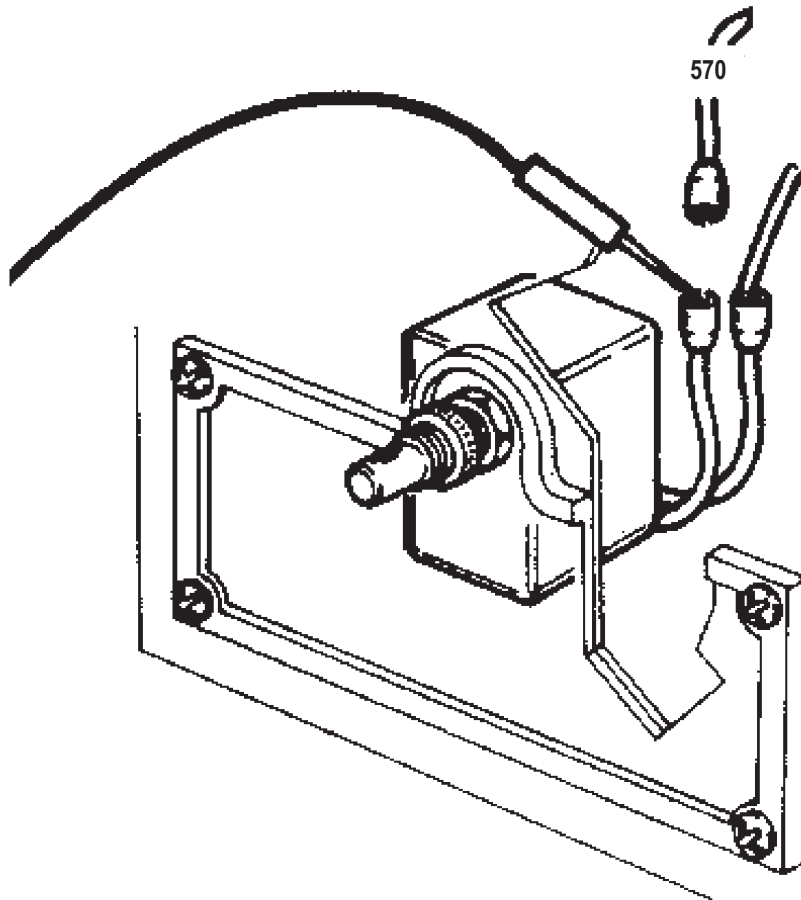

T0480DAA

Figure 5. Ether Start Switch Circuit 570 Wire.

ENGINE CRANKS BUT WILL NOT START IN COLD WEATHER (FUEL SYSTEM OPERATING PROPERLY) - Continued

- c. Make sure battery switch is in ON position.
- d. Connect red lead to circuit 570 ether start switch connector.
- e. Connect black lead to good ground.
- f. Multimeter will display volts DC.
- g. Depress ether start switch.

NOTE

If battery voltage is present, circuit 570 wire is faulty.

- h. Meter reading should be greater than 18 VDC.

CONDITION/INDICATION

DOES CIRCUIT 570 WIRE CONDUCT BATTERY VOLTAGE TO FUEL PRESSURE SWITCH?

DECISION

YES - Go to Step (6).

NO - Repair circuit 570 wire to fuel pressure switch (Volume 3, WP 0352). Go to Step (10) to verify problem is solved.

ENGINE CRANKS BUT WILL NOT START IN COLD WEATHER (FUEL SYSTEM OPERATING PROPERLY) - Continued

STEP

6. DOES ETHER START SWITCH OPERATE PROPERLY?

- a. Check for battery voltage at circuit 570 wire to circuit 5C connector. Refer to point to point schematics.
- b. Disconnect circuit 570 wire to circuit 5C connector at ether start switch.

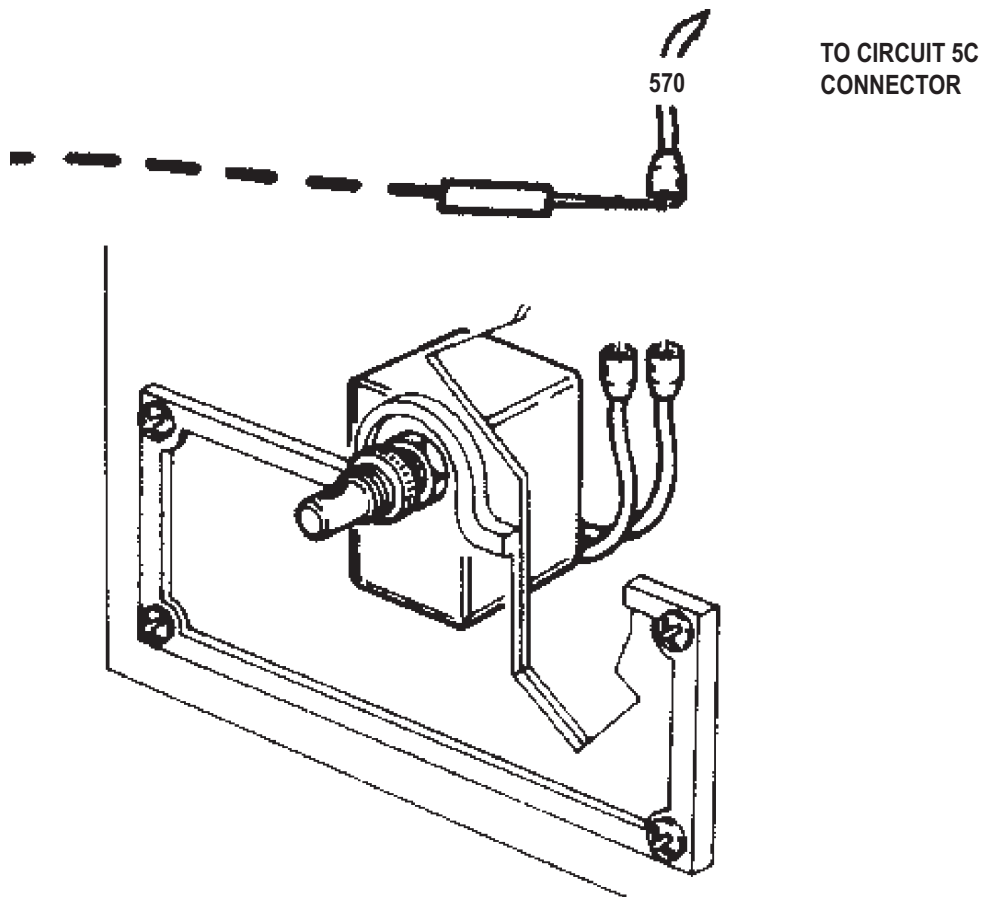

T0481DAA

Figure 6. Ether Start Switch Circuit 5C Wire.

ENGINE CRANKS BUT WILL NOT START IN COLD WEATHER (FUEL SYSTEM OPERATING PROPERLY) - Continued

- c. Make sure battery switch is in ON position.
- d. Connect red lead to circuit 570 wire.
- e. Connect black lead to good ground.

NOTE

If battery voltage is present, ether start switch is faulty.

- f. Meter reading should be greater than 18 VDC.

CONDITION/INDICATION

DOES ETHER START SWITCH OPERATE PROPERLY?

DECISION

YES - Repair circuit 570 wire to circuit 5C connector (Volume 3, WP 0352). Go to Step (10) to verify problem is solved.

NO - Replace ether start switch (Volume 2, WP 0307). Go to Step (10) to verify problem is solved.

ENGINE CRANKS BUT WILL NOT START IN COLD WEATHER (FUEL SYSTEM OPERATING PROPERLY) - Continued

STEP

7. DOES ETHER VALVE OPERATE PROPERLY?
- Disconnect tubing at ether valve (Volume 2, WP 0263).
 - Place battery switch to ON position.
 - Depress ether start switch.

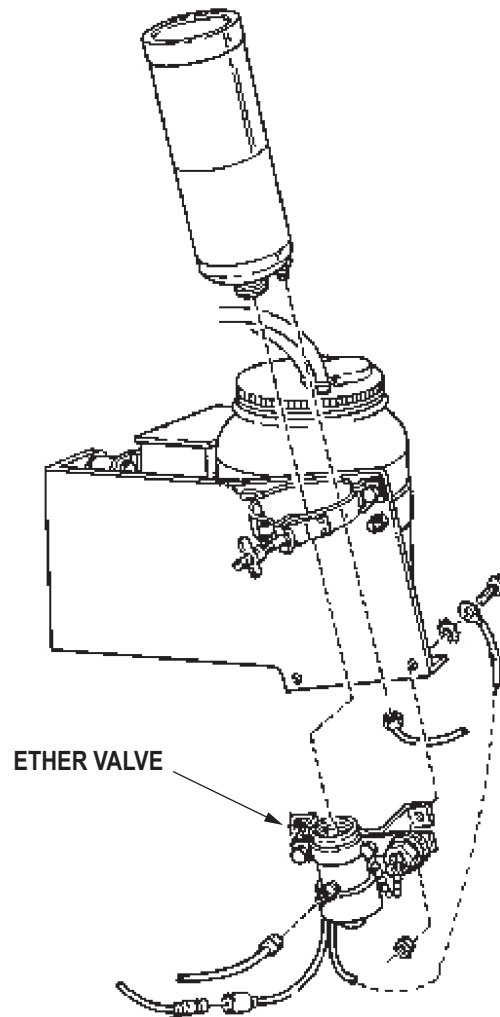

T0482DAA

Figure 7. Ether Valve.

**ENGINE CRANKS BUT WILL NOT START IN COLD WEATHER (FUEL SYSTEM OPERATING PROPERLY) -
Continued**

- d. Check if a small amount of ether is dispensed.

CONDITION/INDICATION

DOES ETHER VALVE OPERATE PROPERLY?

DECISION

YES - Go to Step (8).

NO - Replace defective ether valve (Volume 2, WP 0263). Go to Step (10) to verify problem is solved.

ENGINE CRANKS BUT WILL NOT START IN COLD WEATHER (FUEL SYSTEM OPERATING PROPERLY) - Continued

STEP

8. IS THERMAL CLOSE VALVE OR THERMAL CLOSE VALVE TUBING RESTRICTED?
- a. Disconnect ether valve to thermal close valve tubing at ether valve (Volume 2, WP 0263).
 - b. Disconnect thermal close valve to atomizer tubing at thermal close valve (Volume 2, WP 0263).

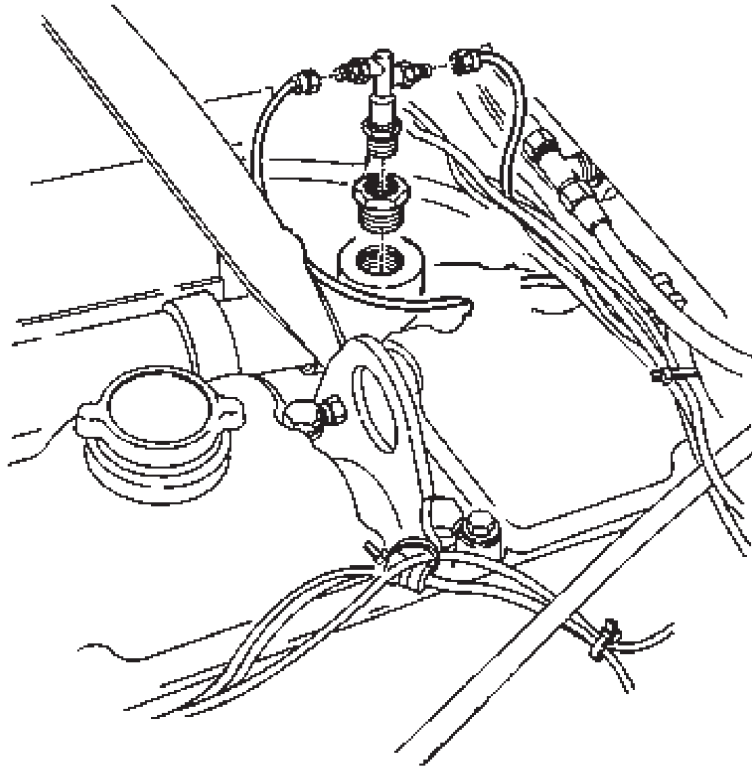

T0483DAA

Figure 8. Thermal Close Valve.

- c. With thermal close valve cold, blow compressed air into tubing at ether valve end to determine if system is clear.
- d. If restricted, disconnect tubing from thermal close valve and check for restrictions in tubing.

CONDITION/INDICATION

IS THERMAL CLOSE VALVE OR THERMAL CLOSE VALVE TUBING RESTRICTED?

DECISION

- YES - Tubing restricted, replace tubing (Volume 2, WP 0263). Go to Step (10) to verify problem is solved.
 YES - Tubing clear, replace thermal close valve (Volume 2, WP 0264). Go to Step (10) to verify problem is solved.
 NO - Go to Step (9).

ENGINE CRANKS BUT WILL NOT START IN COLD WEATHER (FUEL SYSTEM OPERATING PROPERLY) - Continued**STEP****9. IS ATOMIZER OR ATOMIZER TUBING RESTRICTED?**

- a. Disconnect tubing between thermal close valve and atomizer at thermal close valve (Volume 2, WP 0264).

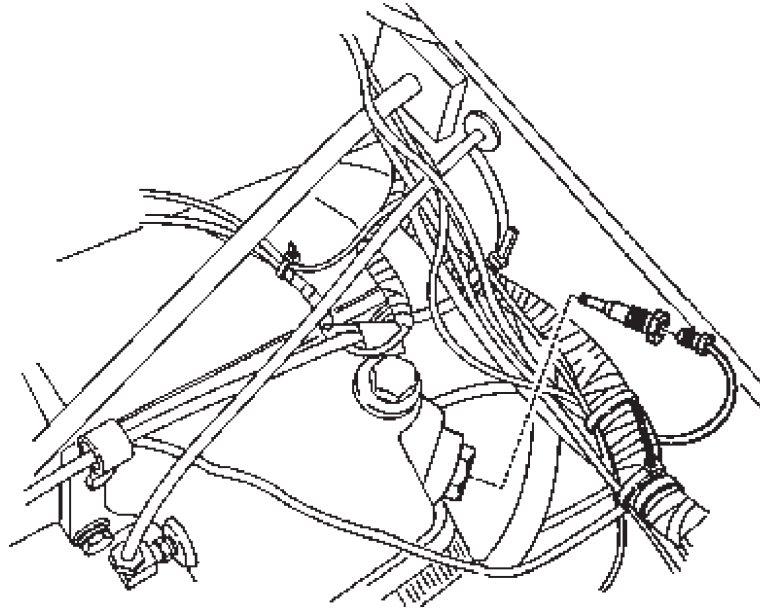

T0484DAA

Figure 9. Atomizer.

- b. Blow compressed air into tubing at thermal close valve end to determine if system is clear.
- c. If restricted, disconnect tubing from atomizer and check for restrictions in tubing.

CONDITION/INDICATION

IS ATOMIZER OR ATOMIZER TUBING RESTRICTED?

DECISION

YES - Tubing restricted, replace tubing (Volume 2, WP 0263). Go to Step (10) to verify problem is solved.
YES - Tubing clear, replace atomizer (Volume 2, WP 0265). Go to Step (10) to verify problem is solved.
NO - Go to Step (10) to verify problem is solved.

**ENGINE CRANKS BUT WILL NOT START IN COLD WEATHER (FUEL SYSTEM OPERATING PROPERLY) -
Continued**

STEP

10. IS YOUR ORIGINAL ETHER START PROBLEM STILL PRESENT?
- a. Ensure vehicle is returned to normal operating condition.
 - b. Check to see if your original ether start problem still exists.

CONDITION/INDICATION

IS YOUR ORIGINAL ETHER START PROBLEM STILL PRESENT?

DECISION

YES - Notify supervisor.
NO - Problem fixed.

END OF WORK PACKAGE

**FIELD MAINTENANCE
EXHAUST COLOR BLUE DURING NORMAL OPERATION**

INITIAL SETUP:**Tools and Special Tools**

Tool Kit, General Mechanic's: Automotive
(Volume 5, WP 0826, Table 1, Item 56)

Personnel Required

(2)

References

Point to Point Schematics

References (cont.)

TM 9-2320-272-10
Volume 2, WP 0232
Volume 2, WP 0250
Volume 5, WP 0820

Equipment Condition

Vehicle parked and engine shut down.
(TM 9-2320-272-10)

TROUBLESHOOTING PROCEDURE**EXHAUST COLOR BLUE DURING NORMAL OPERATION****NOTE**

Conduct these malfunction tests if exhaust smoke is blue during normal operation. This procedure will check for the correct engine oil and fuel.

STEP

1. IS CORRECT OIL IN ENGINE?

Check that engine oil grade is correct for vehicle use and climatic conditions (Volume 5, WP 0820).

CONDITION/INDICATION

IS CORRECT OIL IN ENGINE?

DECISION

YES - Go to Step (2).

NO - Replace engine oil and filter (Volume 2, WP 0232). Go to Step (3) to verify problem is solved.

STEP

2. IS CORRECT FUEL BEING USED?

Check that engine fuel grade is correct for vehicle use and climatic conditions (TM 9-2320-272-10).

CONDITION/INDICATION

IS CORRECT FUEL BEING USED?

DECISION

YES - Notify supervisor. It is possible that another troubleshooting work package applies.

NO - Drain fuel system (Volume 2, WP 0250) and replace with correct grade of fuel (TM 9-2320-272-10). Go to Step (3) to verify problem is solved.

EXHAUST COLOR BLUE DURING NORMAL OPERATION - Continued**STEP**

3. IS YOUR ORIGINAL PROBLEM STILL PRESENT?
 - a. Ensure vehicle is returned to normal operating condition.
 - b. Check to see if your original problem still exists.

CONDITION/INDICATION

IS YOUR ORIGINAL PROBLEM STILL PRESENT?

DECISION

YES - Notify supervisor.
NO - Problem fixed.

END OF WORK PACKAGE

**FIELD MAINTENANCE
EXHAUST COLOR WHITE DURING NORMAL OPERATION**

INITIAL SETUP:**Tools and Special Tools**

Tool Kit, General Mechanic's: Automotive
(Volume 5, WP 0826, Table 1, Item 56)

Personnel Required

(2)

References

Point to Point Schematics

References (cont.)

TM 9-2320-272-10
WP 0028
Volume 2, WP 0250
Volume 2, WP 0258

Equipment Condition

Vehicle parked and engine shut down.
(TM 9-2320-272-10)

TROUBLESHOOTING PROCEDURE**EXHAUST COLOR WHITE DURING NORMAL OPERATION****NOTE**

Conduct these malfunction tests if exhaust smoke is white during normal operation. This procedure will check for engine overheating and water in fuel.

STEP

1. IS ENGINE ABOVE NORMAL OPERATING TEMPERATURE?

CAUTION

Thick white smoke indicates coolant is present in engine combustion chambers during operation. When this condition is evident, shut down immediately and determine cause. Continued engine operations may result in permanent damage to engine.

- a. Check engine temperature.
- b. Ensure engine temperature is within normal operating range 175°F to 200°F (79°C to 93°C).

CONDITION/INDICATION

IS ENGINE ABOVE NORMAL OPERATING TEMPERATURE?

DECISION

YES - Perform Engine Overheats troubleshooting (WP 0028).
NO - Go to Step (2).

EXHAUST COLOR WHITE DURING NORMAL OPERATION - Continued**STEP****2. IS WATER PRESENT IN FUEL?**

- a. Open drain valves at fuel filter and drain approximately 1 pt (0.473 L) of fuel into a glass container.

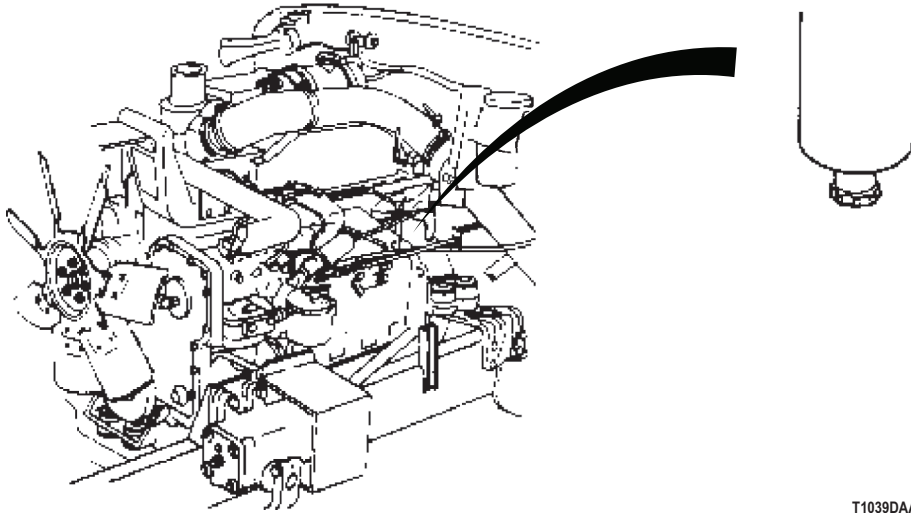

T1039DAA

Figure 1. Fuel Filter.

NOTE

Fuel is contaminated if container is 1/4 full of water.

- b. Check for presence of water in fuel.

CONDITION/INDICATION

IS WATER PRESENT IN FUEL?

DECISION

YES - Drain fuel system (Volume 2, WP 0250), replace fuel filter (Volume 2, WP 0258), and refill fuel tanks (TM 9-2320-272-10). Go to Step (3) to verify problem is solved.

NO - Notify supervisor. Action may not be possible at this level of maintenance.

EXHAUST COLOR WHITE DURING NORMAL OPERATION - Continued**STEP**

3. IS YOUR ORIGINAL PROBLEM STILL PRESENT?
 - a. Ensure vehicle is returned to normal operating condition.
 - b. Check to see if your original problem still exists.

CONDITION/INDICATION

IS YOUR ORIGINAL PROBLEM STILL PRESENT?

DECISION

YES - Notify supervisor.
NO - Problem fixed.

END OF WORK PACKAGE

FIELD MAINTENANCE
EXHAUST COLOR BLACK DURING NORMAL OPERATION AND IDLE

INITIAL SETUP:**Tools and Special Tools**

Tool Kit, General Mechanic's: Automotive
(Volume 5, WP 0826, Table 1, Item 56)

Personnel Required

(2)

References

Point to Point Schematics

References (cont.)

TM 9-2320-272-10
Volume 2, WP 0239
Volume 2, WP 0251
Volume 2, WP 0258

Equipment Condition

Vehicle parked and engine shut down.
(TM 9-2320-272-10)

TROUBLESHOOTING PROCEDURE**EXHAUST COLOR BLACK DURING NORMAL OPERATION AND IDLE****NOTE**

Conduct these malfunction tests if there is black exhaust smoke at idle. This procedure will check for fuel contamination or a restricted air filter.

EXHAUST COLOR BLACK DURING NORMAL OPERATION AND IDLE - Continued**STEP**

1. IS FUEL CONTAMINATED?

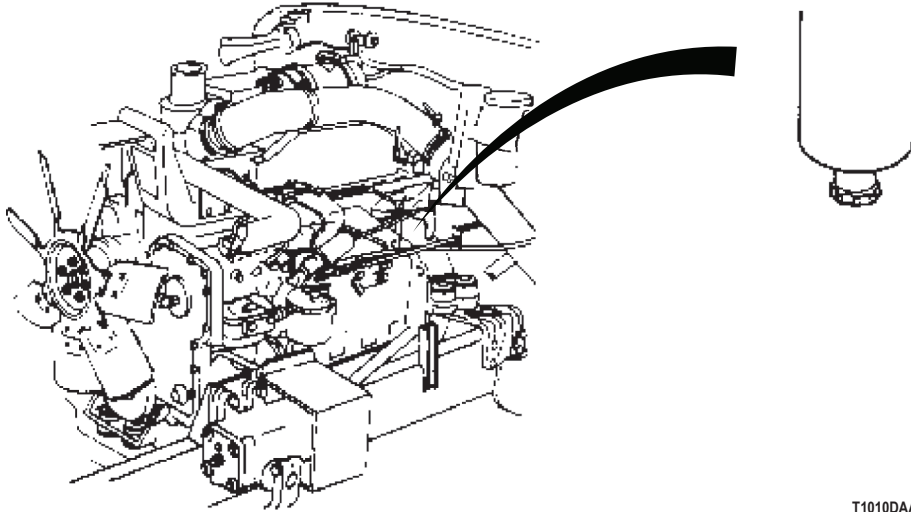

T1010DAA

Figure 1. Fuel Filter.

NOTE

Fuel is contaminated if container is 1/4 full of water or contains dirt.

Open drain valves at fuel filter and drain approximately 1 pt (0.473 L) of fuel into glass container.

CONDITION/INDICATION

IS FUEL CONTAMINATED?

DECISION

- YES - Go to Step (2).
- NO - Go to Step (4).

EXHAUST COLOR BLACK DURING NORMAL OPERATION AND IDLE - Continued**STEP****2. IS FUEL CONTAMINATED?**

Open drain valves at fuel filter and continue to drain fuel up to 1 qt (0.946 L) of fuel into glass container.

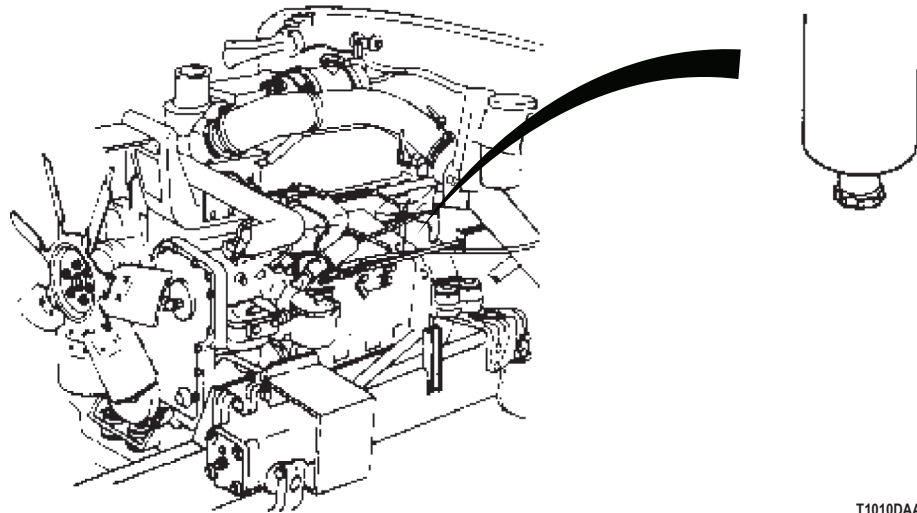

T1010DAA

Figure 2. Fuel Filter.

CONDITION/INDICATION

IF FUEL CONTAMINATED?

DECISION

YES - Go to Step (3).

NO - Go to Step (4).

EXHAUST COLOR BLACK DURING NORMAL OPERATION AND IDLE - Continued**STEP**

3. DOES BLACK SMOKE GO AWAY AFTER CLEANING FUEL SYSTEM?
 - a. Drain fuel tank (Volume 2, WP 0250).

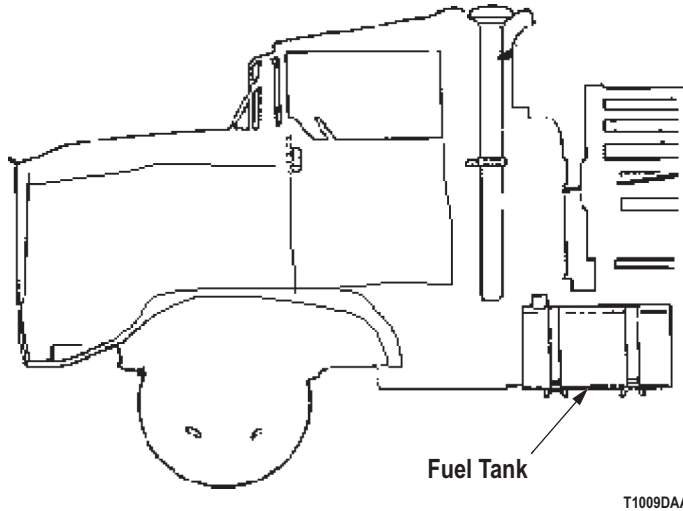
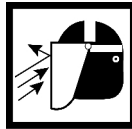

Figure 3. Fuel Tank.

WARNING

Eyeshields must be worn when cleaning with compressed air. Compressed air source will not exceed 30 psi (207 kPa). Failure to comply may result in injury or death to personnel.

- b. Clean and flush fuel system. Dry with compressed air.
- c. Replace fuel filter (Volume 2, WP 0258).
- d. Refill tank with fuel.
- e. Prime fuel system M939/A1 (TM 9-2320-272-10), M939A2 (Volume 2, WP 0239).
- f. Start engine.

CONDITION/INDICATION

DOES BLACK SMOKE GO AWAY? START AFTER CLEANING FUEL SYSTEM.

DECISION

YES - Problem corrected.
 NO - Go to Step (4).

EXHAUST COLOR BLACK DURING NORMAL OPERATION AND IDLE - Continued**STEP**

4. IS AIR CLEANER INDICATOR IN RED ZONE?
 - a. Check air cleaner indicator for air restriction indication.

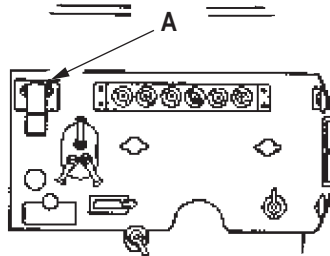

A AIR CLEANER INDICATOR

T0394DAA

Figure 4. Air Cleaner Indicator.

- b. Clean air intake stack of any restrictions.

CONDITION/INDICATION

IS AIR CLEANER INDICATOR IN RED ZONE?

DECISION

YES - Perform air cleaner servicing (TM 9-2320-272-10). Go to Step (5) to verify problem is solved.
 NO - Notify supervisor. Action may not be possible at this level of maintenance.

STEP

5. IS YOUR ORIGINAL SMOKE PROBLEM STILL PRESENT?
 - a. Ensure vehicle is returned to normal operating condition.
 - b. Check to see if your original smoke problem still exists.

CONDITION/INDICATION

IS YOUR ORIGINAL SMOKE PROBLEM STILL PRESENT?

DECISION

YES - Notify supervisor.
 NO - Problem fixed.

END OF WORK PACKAGE

**FIELD MAINTENANCE
EXCESSIVE EXHAUST NOISE**

INITIAL SETUP:**Tools and Special Tools**

Tool Kit, General Mechanic's: Automotive
(Volume 5, WP 0826, Table 1, Item 56)

Personnel Required

(2)

References

Point to Point Schematics

References (cont.)

Volume 2, WP 0273
Volume 2, WP 0274
Volume 2, WP 0275
Volume 2, WP 0276

Equipment Condition

Vehicle parked and engine shut down.
(TM 9-2320-272-10)

TROUBLESHOOTING PROCEDURE**EXCESSIVE EXHAUST NOISE****NOTE**

Conduct these malfunction tests if there is excessive exhaust noise. This procedure will check for damage to the muffler and exhaust system pipes and gaskets.

EXCESSIVE EXHAUST NOISE - Continued**STEP**

1. IS MUFFLER IN GOOD OPERATING CONDITION?
 - a. Make sure engine is turned OFF.

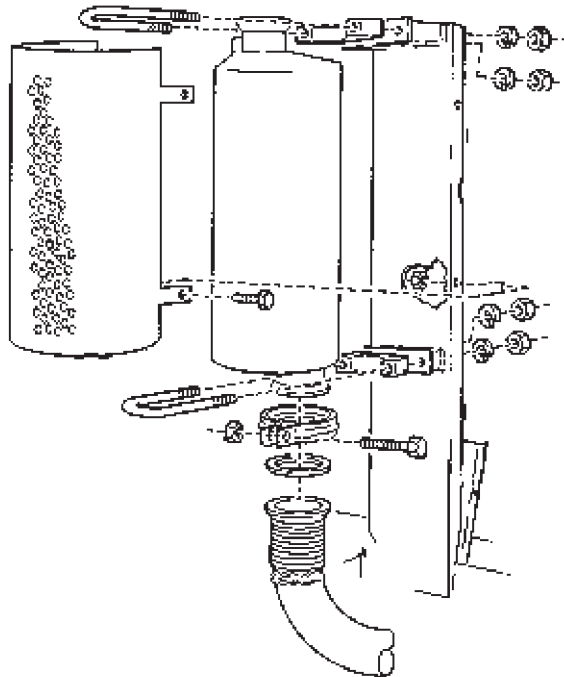

T0486DAA

*Figure 1. Muffler.***WARNING**

Do not touch hot exhaust system components with bare hands. Failure to comply may result in injury or death to personnel.

- b. Visually inspect muffler for wear and damage.

CONDITION/INDICATION

IS MUFFLER IN GOOD OPERATING CONDITION?

DECISION

YES - Go to Step (2).

NO - Replace muffler (Volume 2, WP 0274). Go to Step (3) to verify problem is solved.

EXCESSIVE EXHAUST NOISE - Continued**STEP**

2. ARE EXHAUST PIPES AND GASKETS IN GOOD OPERATING CONDITION?

WARNING

Do not touch hot exhaust system components with bare hands. Failure to comply may result in injury or death to personnel.

Visually inspect gaskets and front and rear exhaust pipes for cracks and damage.

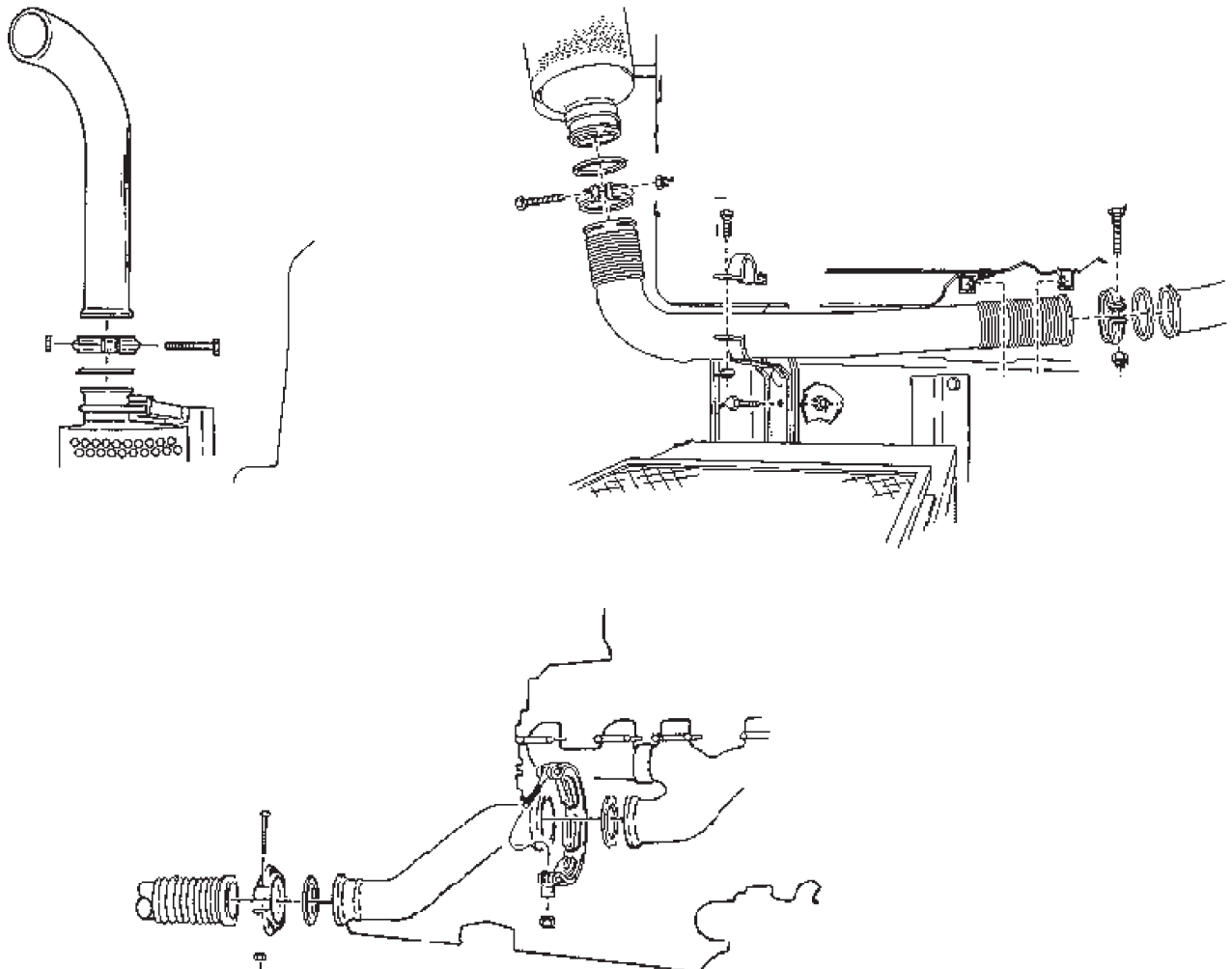

T0487DAA

Figure 2. Exhaust System (M939/A1).

EXCESSIVE EXHAUST NOISE - Continued

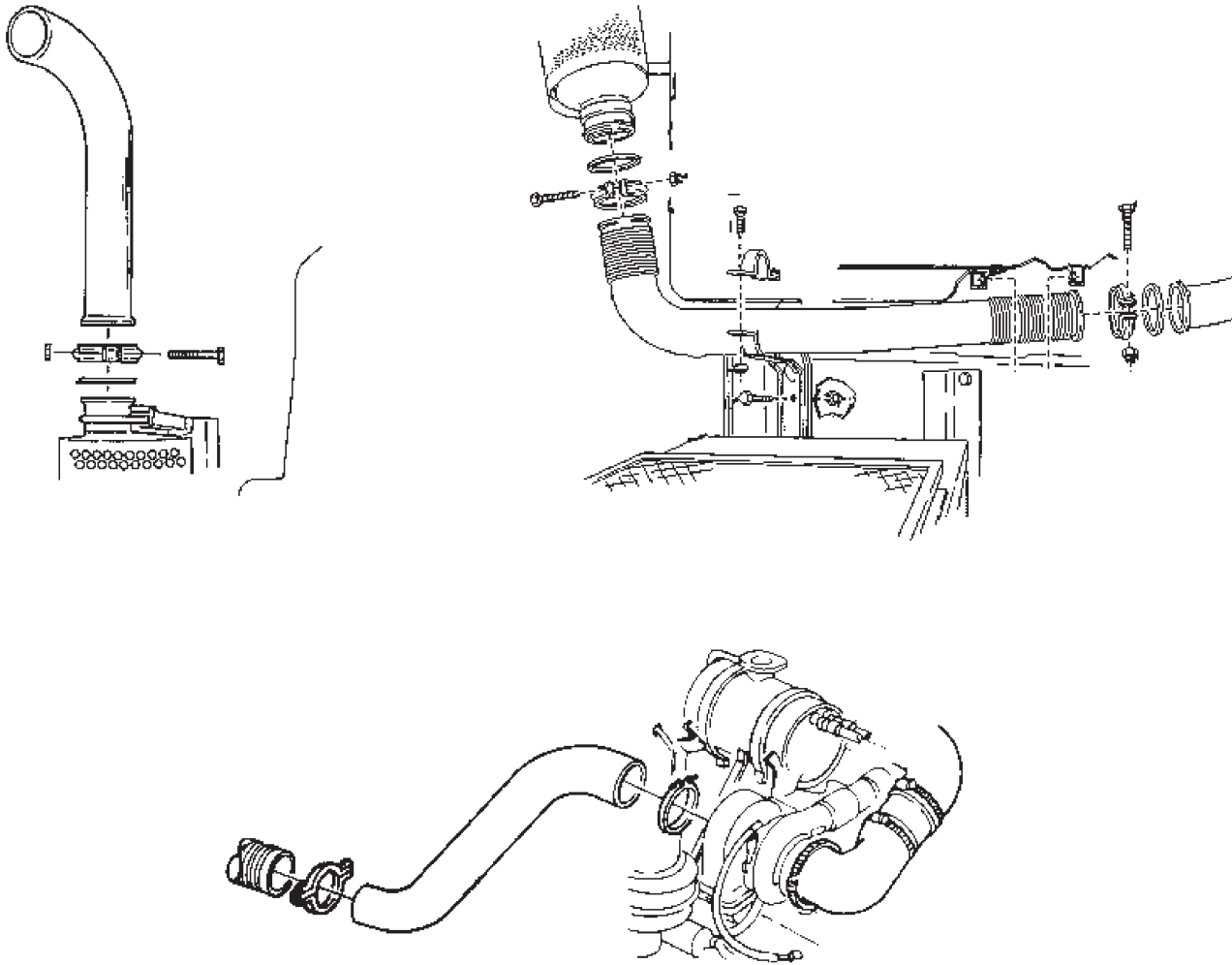

T0488DAA

Figure 3. Exhaust System (M939A2).

EXCESSIVE EXHAUST NOISE - Continued**CONDITION/INDICATION**

ARE EXHAUST PIPES AND GASKETS IN GOOD OPERATING CONDITION?

DECISION

NO - Front exhaust pipe damaged. Replace front exhaust pipe (Volume 2, WP 0276). Go to Step (3) to verify problem is solved.

NO - Front pipe gasket damaged. Replace gasket (Volume 2, WP 0276). Go to Step (3) to verify problem is solved.

NO - Rear exhaust pipe damaged. Replace rear exhaust pipe (Volume 2, WP 0275). Go to Step (3) to verify problem is solved.

NO - Rear pipe gasket damaged. Replace gasket (Volume 2, WP 0275). Go to Step (3) to verify problem is solved.

NO - Exhaust stack damaged. Replace exhaust stack (Volume 2, WP 0273). Go to Step (3) to verify problem is solved.

NO - Exhaust stack gasket damaged. Replace gasket (Volume 2, WP 0273). Go to Step (3) to verify problem is solved.

YES - Go to Step (3) to verify problem is solved.

STEP

3. IS YOUR ORIGINAL EXHAUST NOISE PROBLEM STILL PRESENT?

- a. Ensure vehicle is returned to normal operating condition.
- b. Check to see if your original exhaust noise problem still exists.

CONDITION/INDICATION

IS YOUR ORIGINAL EXHAUST NOISE PROBLEM STILL PRESENT?

DECISION

YES - Notify supervisor.

NO - Problem fixed.

END OF WORK PACKAGE

**FIELD MAINTENANCE
EXHAUST FUMES IN CAB**

INITIAL SETUP:**Tools and Special Tools**

Tool Kit, General Mechanic's: Automotive
(Volume 5, WP 0826, Table 1, Item 56)

References (cont.)

Volume 2, WP 0273
Volume 2, WP 0275
Volume 2, WP 0276

Personnel Required

(2)

Equipment Condition

Vehicle parked and engine shut down.
(TM 9-2320-272-10)

References

Point to Point Schematics

TROUBLESHOOTING PROCEDURE**EXHAUST FUMES IN CAB****NOTE**

Conduct these malfunction tests if exhaust fumes are in cab. This procedure will check for leaks from exhaust system pipe connections or damaged exhaust pipes.

EXHAUST FUMES IN CAB - Continued

STEP

1. ARE PIPE CONNECTIONS LEAKING?
 - a. Start vehicle engine.

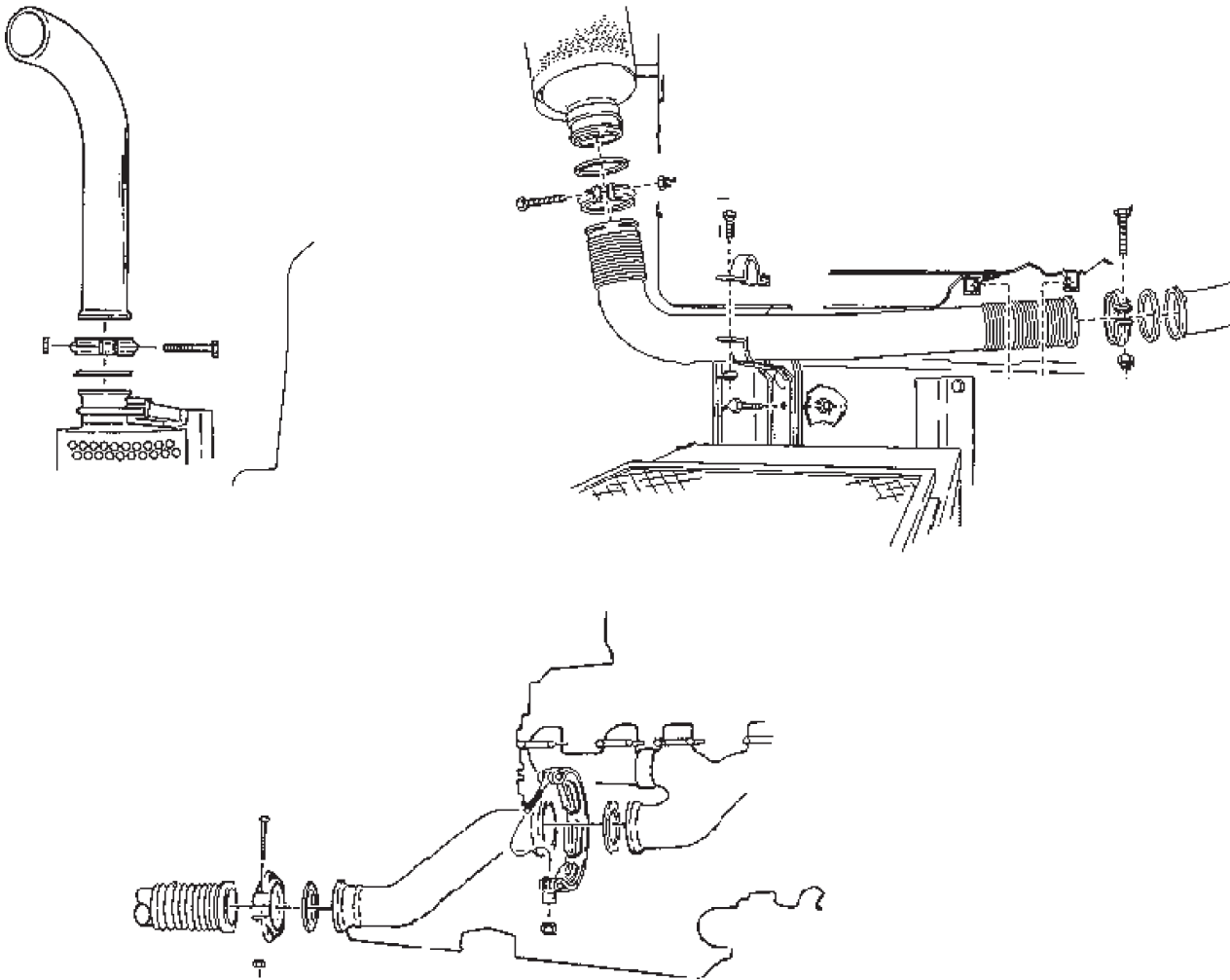

T1017DAA

Figure 1. Exhaust System (M939/A1).

EXHAUST FUMES IN CAB - Continued

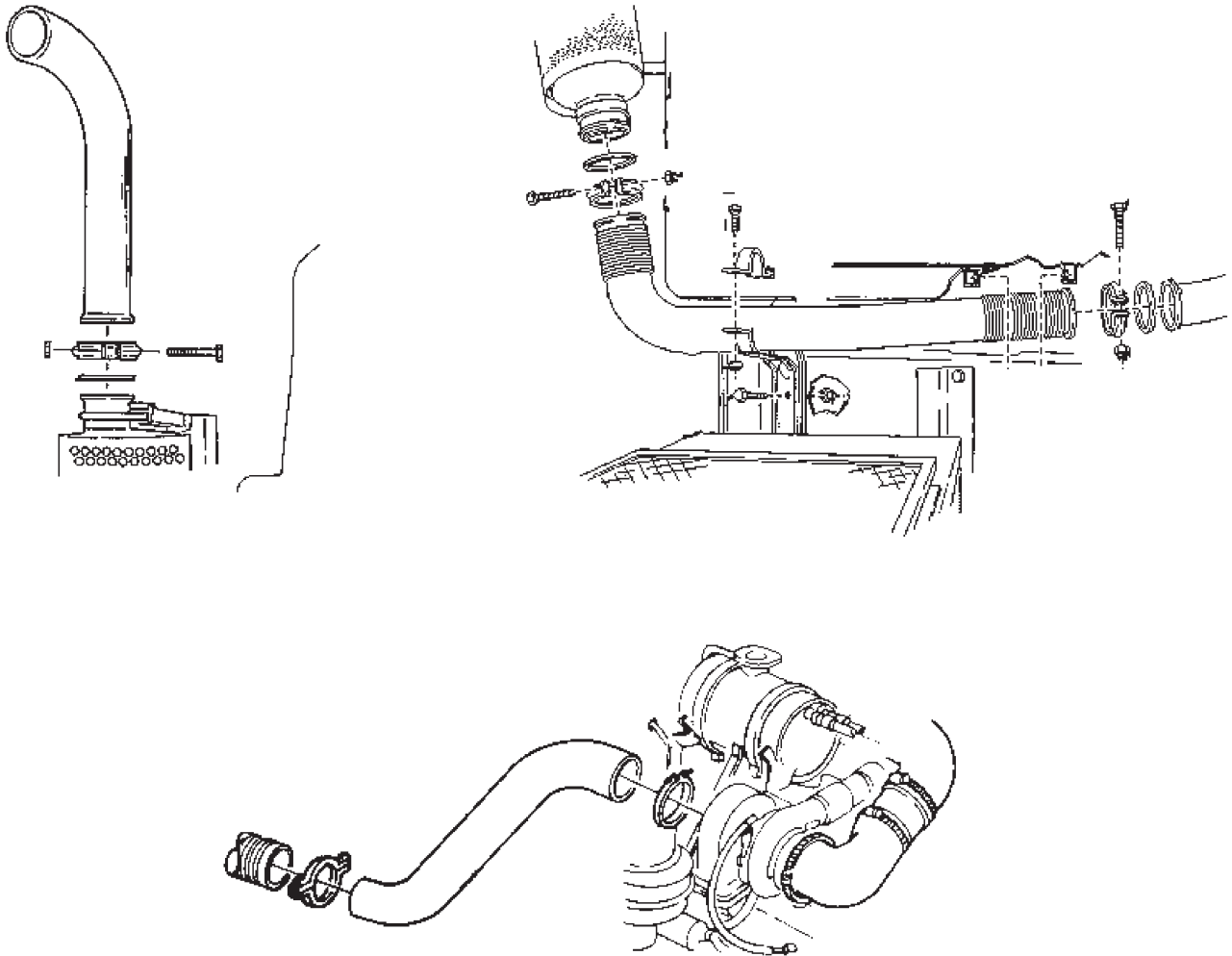

T1107DAA

Figure 2. Exhaust System (M939A2).

WARNING

Do not touch hot exhaust system components with bare hands. Failure to comply may result in injury or death to personnel.

- b. Look for leaking fumes at connections.
- c. Determine location of leaking connection.

EXHAUST FUMES IN CAB - Continued**CONDITION/INDICATION**

ARE PIPE CONNECTIONS LEAKING?

DECISION

YES - Exhaust stack leaking. Replace gasket (Volume 2, WP 0273). Go to Step (3) to verify problem is solved.

YES - Rear pipe leaking. Replace gasket (Volume 2, WP 0275). Go to Step (3) to verify problem is solved.

YES - Front pipe leaking. Replace gasket (Volume 2, WP 0276). Go to Step (3) to verify problem is solved.

NO - Go to Step (2).

STEP

2. ARE MANIFOLD OR EXHAUST PIPES LEAKING FUMES?

WARNING

Do not touch hot exhaust system components with bare hands. Failure to comply may result in injury or death to personnel.

Visually inspect manifold and exhaust pipes for cracks or damage.

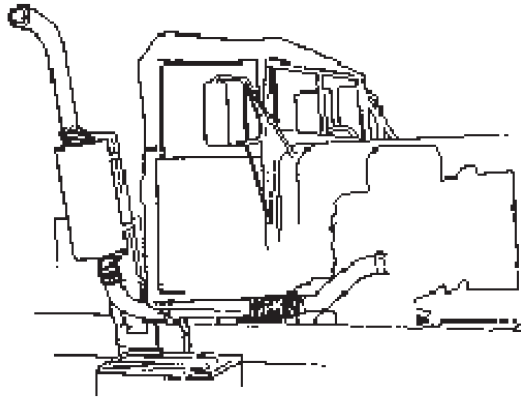

T1016DAA

Figure 3. Exhaust System.

EXHAUST FUMES IN CAB - Continued**CONDITION/INDICATION**

ARE MANIFOLD OR EXHAUST PIPES LEAKING FUMES?

DECISION

YES - Exhaust stack pipe damaged. Replace exhaust stack (Volume 2, WP 0273). Go to Step (3) to verify problem is solved.

YES - Rear pipe damaged. Replace rear exhaust pipe (Volume 2, WP 0275). Go to Step (3) to verify problem is solved.

YES - Front pipe damaged. Replace front exhaust pipe (Volume 2, WP 0276). Go to Step (3) to verify problem is solved.

NO - Go to Step (3) to verify problem is solved.

STEP

3. IS YOUR ORIGINAL FUMES IN CAB PROBLEM STILL PRESENT?
 - a. Ensure vehicle is returned to normal operating condition.
 - b. Check to see if your original fumes in cab problem still exists.

CONDITION/INDICATION

IS YOUR ORIGINAL FUMES IN CAB PROBLEM STILL PRESENT?

DECISION

YES - Notify supervisor.

NO - Problem fixed.

END OF WORK PACKAGE

FIELD MAINTENANCE
ENGINE DOES NOT REACH NORMAL OPERATING TEMPERATURE

INITIAL SETUP:**Tools and Special Tools**

Tool Kit, General Mechanic's: Automotive
(Volume 5, WP 0826, Table 1, Item 56)
Test Set, Electronic Systems
(Volume 5, WP 0826, Table 1, Item 51)

Personnel Required

(2)

References

Point to Point Schematics
TM 9-2320-272-10
Volume 2, WP 0288

References (cont.)

Volume 2, WP 0289
Volume 2, WP 0295
Volume 2, WP 0296
Volume 2, WP 0298
Volume 2, WP 0334
Volume 3, WP 0447
Volume 3, WP 0448

Equipment Condition

Vehicle parked and engine shut down.
(TM 9-2320-272-10)

TROUBLESHOOTING PROCEDURE**ENGINE DOES NOT REACH NORMAL OPERATING TEMPERATURE****NOTE**

Conduct these malfunction tests if engine does not reach normal operating temperature. This procedure will check for proper thermostat and fan clutch operation.

ENGINE DOES NOT REACH NORMAL OPERATING TEMPERATURE - Continued**STEP**

1. DOES COOLANT CIRCULATE THROUGH SURGE TANK WHEN ENGINE TEMPERATURE IS BELOW 175°F (79°C)?

WARNING

Extreme care should be taken when removing surge tank filler cap if temperature gauge reads below 175°F (79°C). Steam or hot coolant under pressure may cause injury.

- a. Remove surge tank cap.

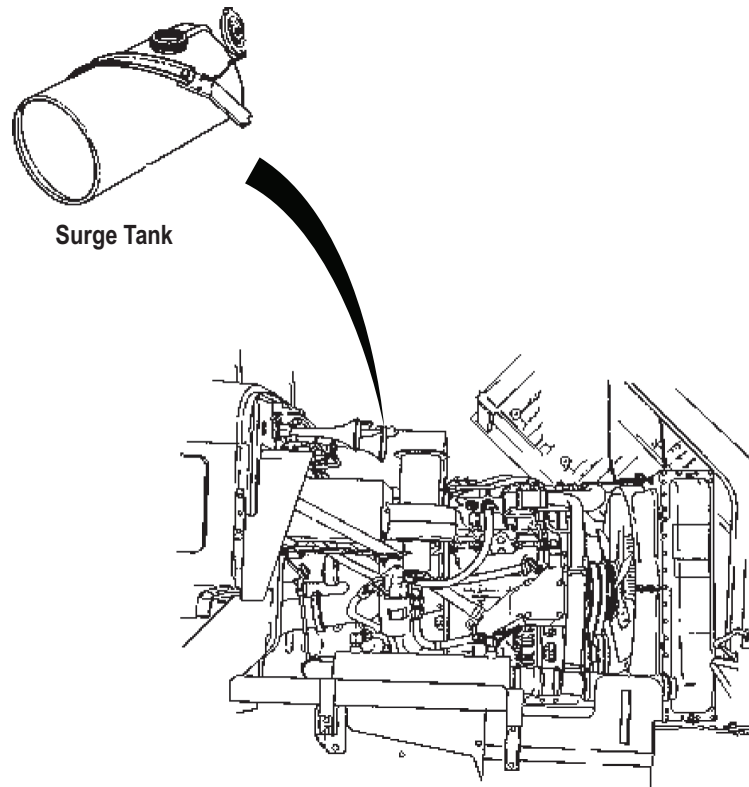

T1056DAA

Figure 1. Surge Tank.

- b. Start engine (TM 9-2320-272-10).
- c. Visually inspect coolant for circulation.
- d. Stop engine.

CONDITION/INDICATION

DOES COOLANT CIRCULATE THROUGH SURGE TANK WHEN ENGINE TEMPERATURE IS BELOW 175°F (79°C)?

ENGINE DOES NOT REACH NORMAL OPERATING TEMPERATURE - Continued**DECISION**

YES - Replace thermostat M939/A1 (Volume 2, WP 0288), M939A2 (Volume 2, WP 0289). Go to Step (4) to verify problem is solved.

NO - Go to Step (2).

STEP**2. DOES FAN DRIVE CLUTCH WORK PROPERLY?**

- a. Inspect fan drive clutch for proper operation.

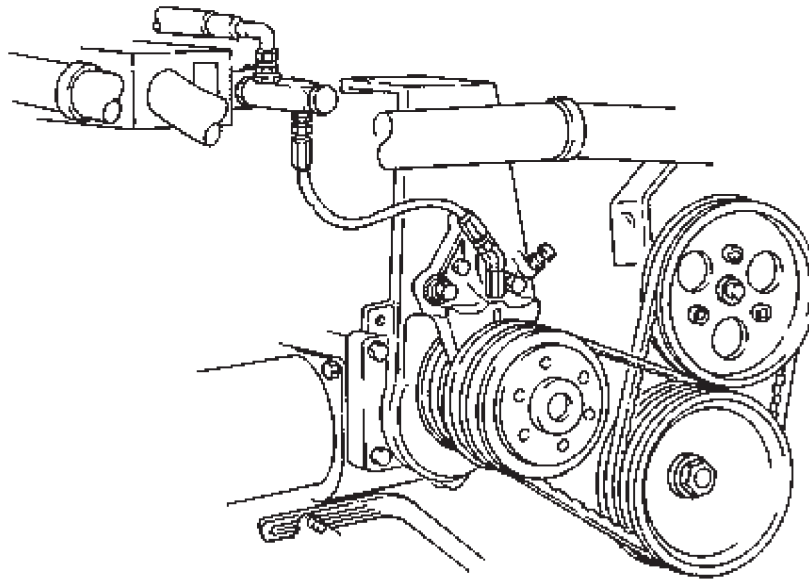

T0071DAA

Figure 2. Fan Clutch.

- b. Make sure override lockup bolts are removed from clutch housing and stored in clutch housing bracket (M939/A1 only) (TM 9-2320-272-10).

CONDITION/INDICATION

DOES FAN DRIVE CLUTCH WORK PROPERLY?

DECISION

YES - Go to Step (3).

NO - Fan drive clutch actuator defective. Replace fan drive clutch actuator M939/A1 (Volume 3, WP 0447), M939A2 (Volume 3, WP 0448). Go to Step (4) to verify problem is solved.

NO - Fan drive clutch defective. Replace fan drive clutch (Volume 2, WP 0295). Go to Step (4) to verify problem is solved.

ENGINE DOES NOT REACH NORMAL OPERATING TEMPERATURE - Continued

STEP

3. DOES COOLANT TEMPERATURE GAUGE OPERATE PROPERLY?
 - a. Place battery switch in OFF position.
 - b. Remove circuit 33 wire from coolant temperature sending unit. Refer to point to point schematics.

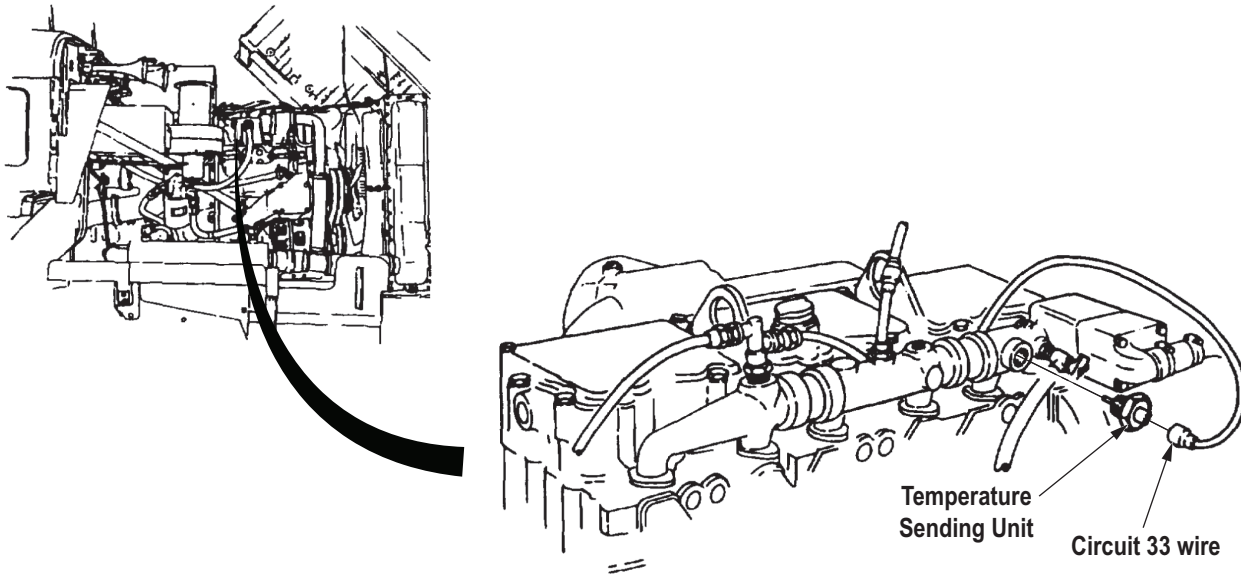

M939/A1 VEHICLES

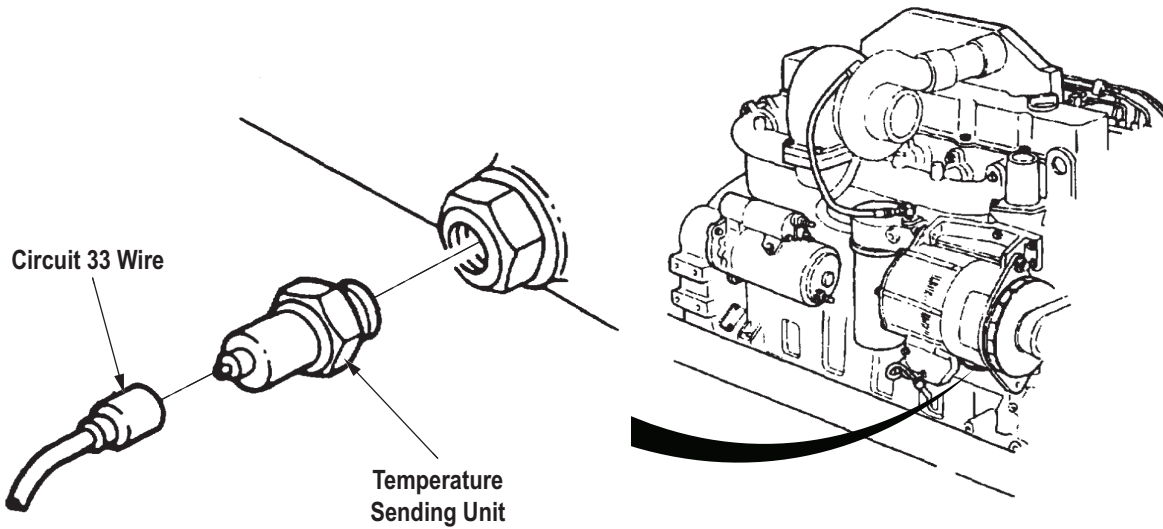

M939/A2 VEHICLES

T1108DAA

Figure 3. Coolant Temperature Sending Unit.

ENGINE DOES NOT REACH NORMAL OPERATING TEMPERATURE - Continued

- c. Place battery switch to ON position.
- d. Have assistant momentarily ground disconnected circuit 33 wire.
- e. Observe coolant temperature gauge for movement.

CONDITION/INDICATION

DOES COOLANT TEMPERATURE GAUGE OPERATE PROPERLY?

DECISION

YES - Replace coolant temperature sending unit (Volume 2, WP 0334). Go to Step (4) to verify problem is solved.

NO - Perform Temperature Gauge Inoperative (Coolant) troubleshooting (WP 0106).

STEP

- 4. IS YOUR ORIGINAL PROBLEM STILL PRESENT?
 - a. Ensure vehicle is returned to normal operating condition.
 - b. Check to see if your original problem still exists.

CONDITION/INDICATION

IS YOUR ORIGINAL PROBLEM STILL PRESENT?

DECISION

YES - Notify supervisor.

NO - Problem fixed.

END OF WORK PACKAGE

FIELD MAINTENANCE ENGINE OVERHEATS

INITIAL SETUP:**Tools and Special Tools**

Tool Kit, General Mechanic's: Automotive
(Volume 5, WP 0826, Table 1, Item 56)
Test Set, Electronic Systems
(Volume 5, WP 0826, Table 1, Item 51)

Personnel Required

(2)

References

Point to Point Schematics
TM 9-2320-272-10
WP 0106
WP 0131
Volume 2, WP 0229
Volume 2, WP 0233
Volume 2, WP 0249
Volume 2, WP 0278
Volume 2, WP 0280
Volume 2, WP 0281

References (cont.)

Volume 2, WP 0283
Volume 2, WP 0284
Volume 2, WP 0285
Volume 2, WP 0286
Volume 2, WP 0287
Volume 2, WP 0293
Volume 2, WP 0294
Volume 2, WP 0296
Volume 2, WP 0297
Volume 2, WP 0298
Volume 2, WP 0299
Volume 2, WP 0334
Volume 3, WP 0447
Volume 3, WP 0448
Volume 5, WP 0820

Equipment Condition

Vehicle parked and engine shut down.
(TM 9-2320-272-10)

TROUBLESHOOTING PROCEDURE**ENGINE OVERHEATS****NOTE**

Conduct these malfunction tests if engine overheats. This procedure will check for improper coolant level, oil level, faulty fan drivebelts, radiator and radiator hoses for leaks and damage, cooling system for clogging, radiator fan for cracked blades, fan clutch, water pump and temperature gauge for malfunctions.

ENGINE OVERHEATS - Continued**STEP**

1. IS ENGINE COOLANT AT PROPER LEVEL?

WARNING

Extreme care should be taken when removing surge tank filler cap if temperature gauge reads above 175°F (79°C). Steam or hot coolant under pressure may escape rapidly or cause burns. Failure to comply may result in injury or death to personnel.

CAUTION

Do not add coolant when engine is hot. Internal engine damage could result.
Visually check engine coolant level.

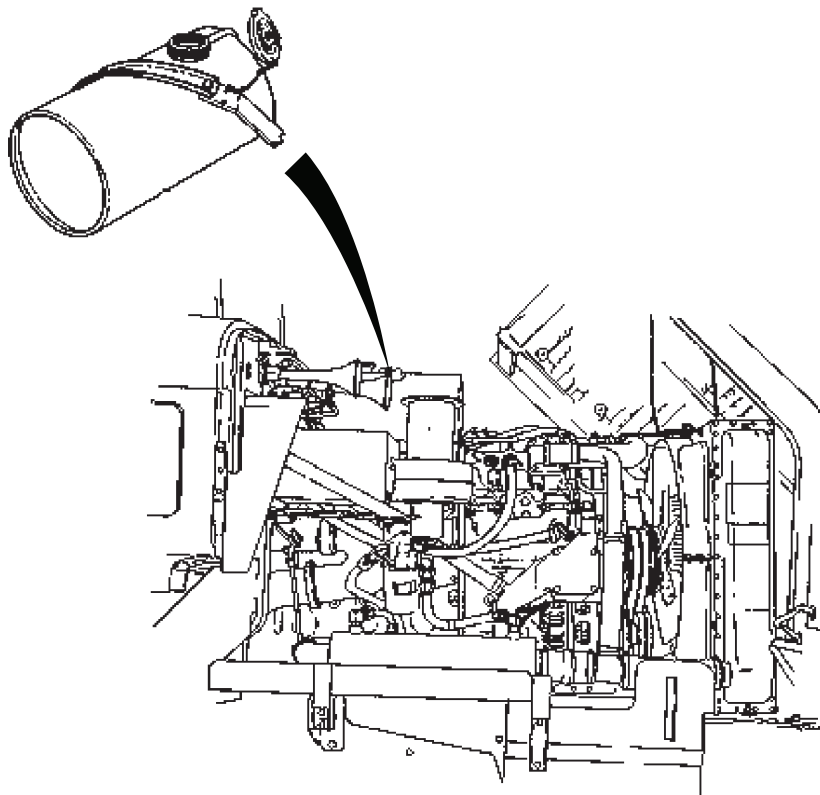

T1013DAA

Figure 1. Surge Tank.

ENGINE OVERHEATS - Continued

CONDITION/INDICATION

IS ENGINE COOLANT AT PROPER LEVEL?

DECISION

NO - Fill coolant to proper level (Volume 2, WP 0287). Go to Step (12) to verify problem is solved.

YES - Go to Step (2).

STEP

2. IS ENGINE OIL AT PROPER LEVEL?

Check dipstick for proper oil level (TM 9-2320-272-10).

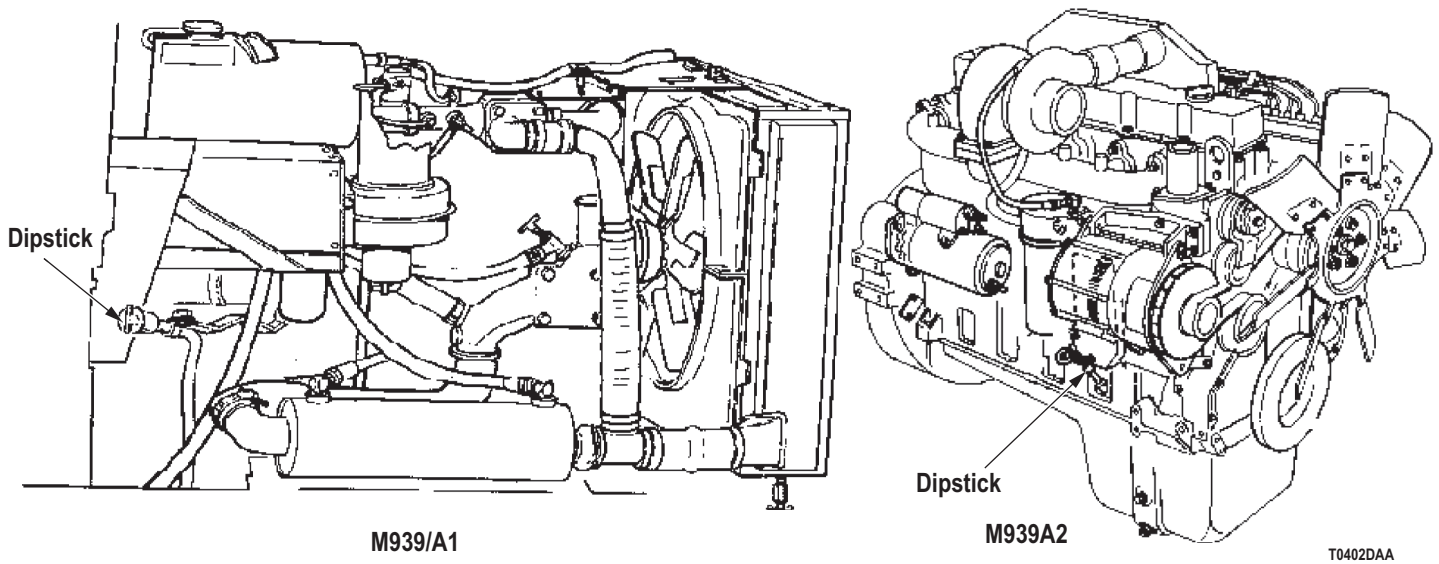

Figure 2. Engine Oil Dipstick.

CONDITION/INDICATION

IS ENGINE OIL AT PROPER LEVEL?

DECISION

NO - Oil level is high. Drain crankcase to safe operating level (Volume 2, WP 0232). Go to Step (12) to verify problem is solved.

NO - Oil level is low. Add to proper operating level (Volume 5, WP 0820). Go to Step (12) to verify problem is solved.

YES - Go to Step (3).

ENGINE OVERHEATS - Continued**STEP****3. IS DRIVE BELT AND TENSIONER IN GOOD CONDITION?**

Visually check drivebelt and tensioner for looseness, missing, or worn out condition.

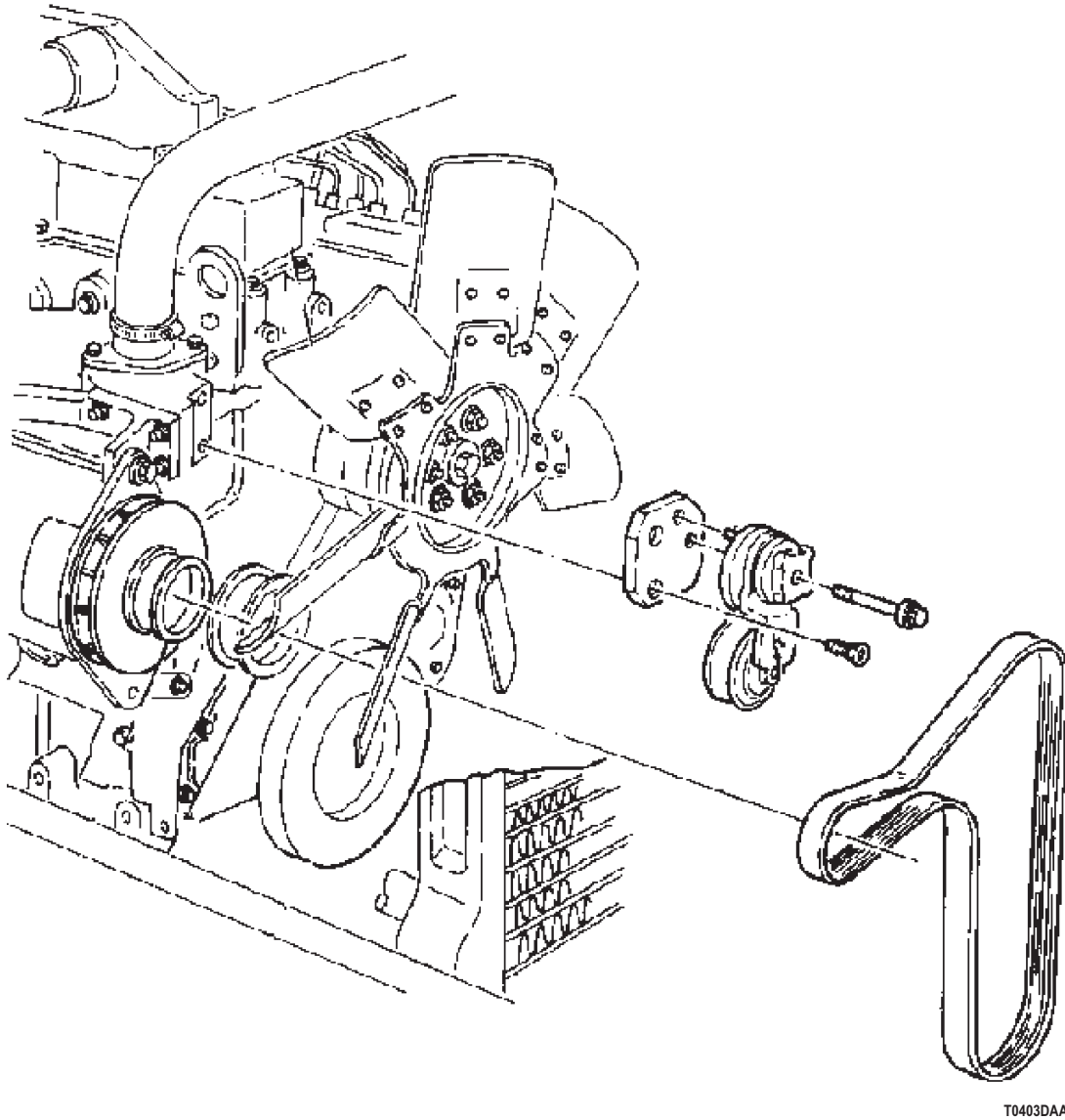

Figure 3. Engine Drive Belt.

ENGINE OVERHEATS - Continued**CONDITION/INDICATION**

IS DRIVE BELT AND TENSIONER IN GOOD CONDITION?

DECISION

NO - Tighten/replace drivebelt or tensioner as necessary M939/A1 (Volume 2, WP 0297), M939A2 (Volume 2, WP 0296). Go to Step (12) to verify problem is solved.

YES - Go to Step (4).

ENGINE OVERHEATS - Continued**STEP****4. ARE RADIATOR, HOSES, HOSE CONNECTIONS, AND DRAIN VALVES LEAKING?**

Visually inspect radiator, hoses, hose connections, and drain valves for leaks.

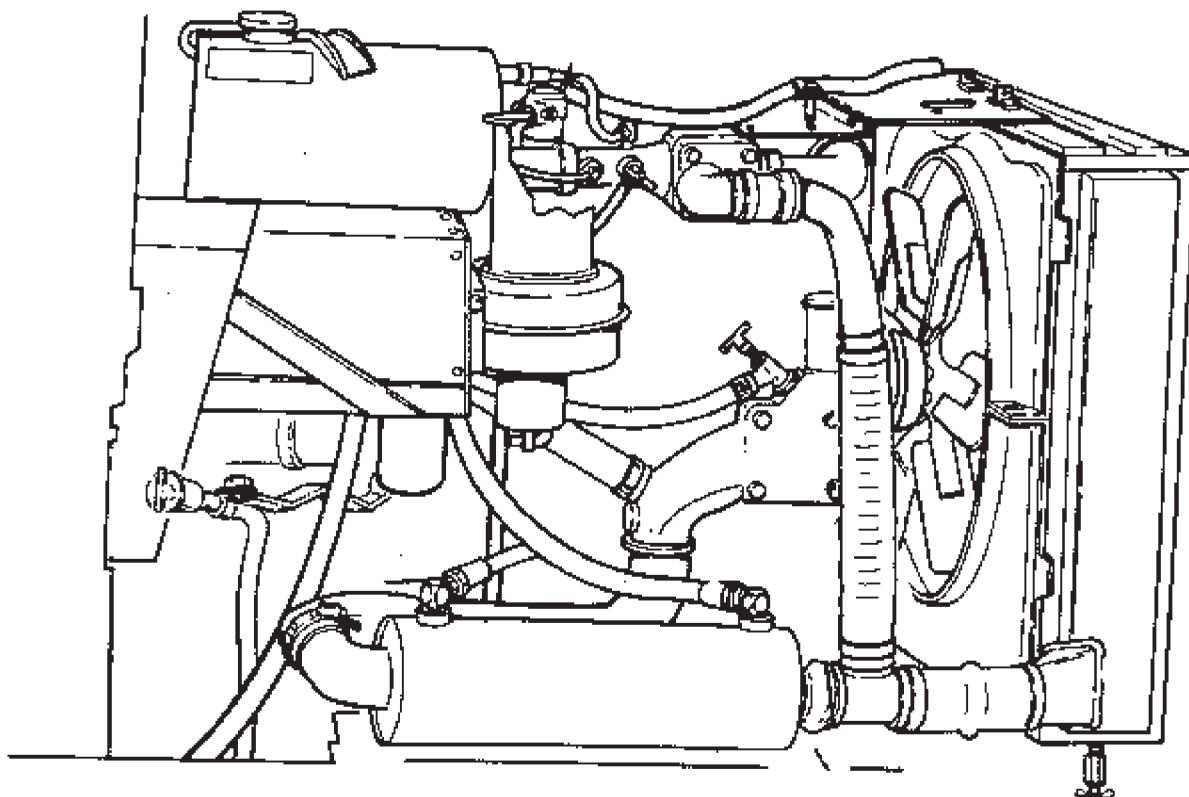

T0068DAA

Figure 4. Engine Cooling System (M939/A1).

ENGINE OVERHEATS - Continued

Figure 5. Engine Cooling System (M939A2).

CONDITION/INDICATION

ARE RADIATOR, HOSES, HOSE CONNECTIONS, AND DRAIN VALVES LEAKING?

DECISION

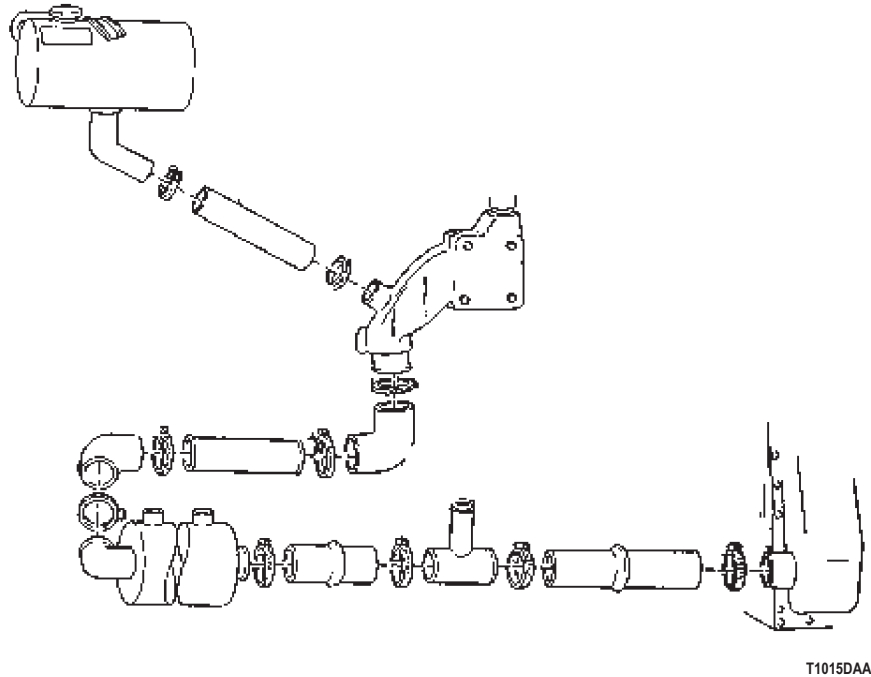
- YES - Turbocharger coolant lines leaking. Tighten or replace coolant lines (Volume 2, WP 0249). Go to Step (12) to verify problem is solved.
- YES - Coolant hoses or tubes leaking. Tighten or replace coolant hoses, clamps, or fittings M939/A1 (Volume 2, WP 0280), M939A2 (Volume 2, WP 0285). Go to Step (12) to verify problem is solved.
- YES - Aftercooler tubes leaking. Tighten or replace aftercooler tubes (Volume 2, WP 0299). Go to Step (12) to verify problem is solved.
- YES - Upper radiator hoses leaking. Tighten or replace upper radiator hoses (Volume 2, WP 0286). Go to Step (12) to verify problem is solved.
- YES - Radiator leaks. Replace radiator (Volume 2, WP 0281). Go to Step (12) to verify problem is solved.
- YES - Water pump leaks. Perform water pump maintenance M939/A1 (Volume 2, WP 0293), M939A2 (Volume 2, WP 0292). Go to Step (12) to verify problem is solved.
- YES - Vent or manifold hoses or fittings leaking. Tighten or replace radiator vent and manifold hoses or fittings (Volume 2, WP 0278). Go to Step (12) to verify problem is solved.
- YES - Air compressor coolant tube leaking - Tighten or replace coolant tube or fittings (Volume 2, WP 0284). Go to Step (12) to verify problem is solved.
- YES - Engine oil cooler coolant tube leaking - Tighten or replace coolant tubes or fittings M939/A1 (Volume 2, WP 0233), M939A2 (Volume 2, WP 0229). Go to Step (12) to verify problem is solved.
- NO - Go to Step (5).

ENGINE OVERHEATS - Continued**STEP****5. IS COOLING SYSTEM CLOGGED?**

Check cooling system for clogging.

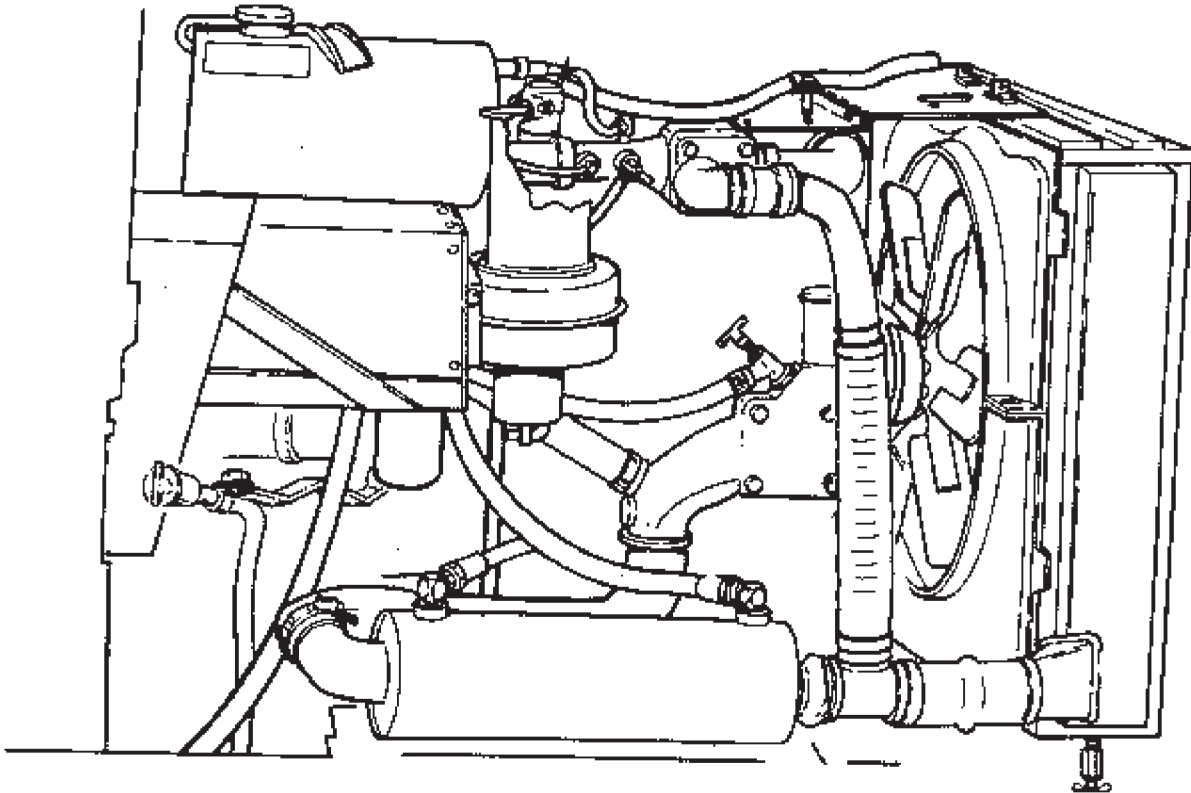

T0068DAA

Figure 6. Engine Cooling System (M939/A1).

ENGINE OVERHEATS - Continued

Figure 7. Engine Cooling System (M939A2).

CONDITION/INDICATION

IS COOLING SYSTEM CLOGGED?

DECISION

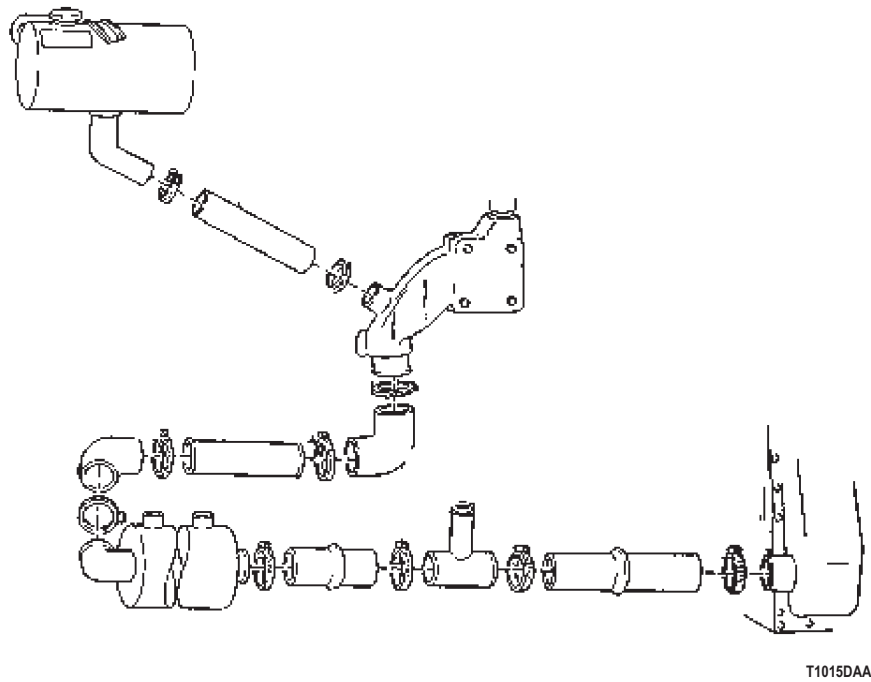
YES - Flush and clean cooling system (Volume 2, WP 0287). Go to Step (12) to verify problem is solved.
NO - Go to Step (6).

ENGINE OVERHEATS - Continued**STEP**

6. IS COOLING FAN IN GOOD CONDITION?
 - a. Make sure engine is not running and is cool.

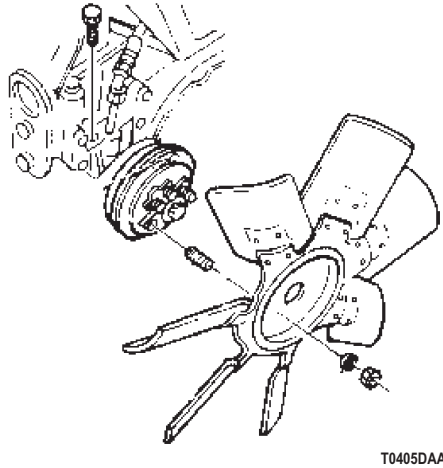

Figure 8. Engine Cooling Fan.

- b. Check cooling fan for damage.

CONDITION/INDICATION

IS COOLING FAN IN GOOD CONDITION?

DECISION

NO - Replace fan M939/A1 (Volume 2, WP 0298), M939A2 (Volume 2, WP 0283). Go to Step (12) to verify problem is solved.

YES - Go to Step (7).

ENGINE OVERHEATS - Continued**STEP****7. IS RADIATOR FREE OF AIRFLOW OBSTRUCTIONS?**

Visually check radiator for airflow obstructions.

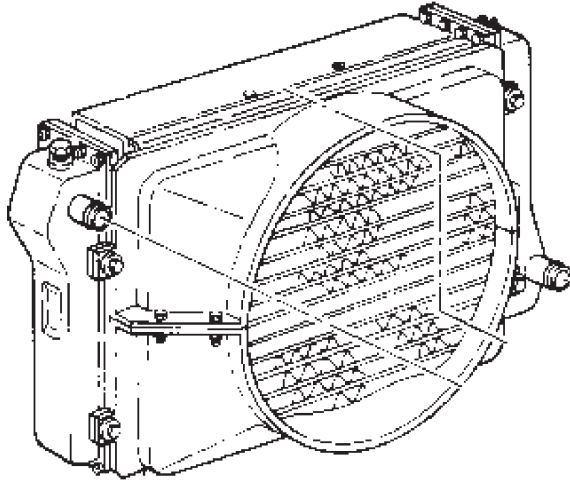

T0406DAA

Figure 9. Radiator.

CONDITION/INDICATION

IS RADIATOR FREE OF AIRFLOW OBSTRUCTIONS?

DECISION

NO - Remove airflow obstructions. Go to Step (12) to verify problem is solved.

YES - Go to Step (8).

ENGINE OVERHEATS - Continued**STEP**

8. IS AIR AVAILABLE TO RUN THE COOLING FAN?
 - a. Start engine.

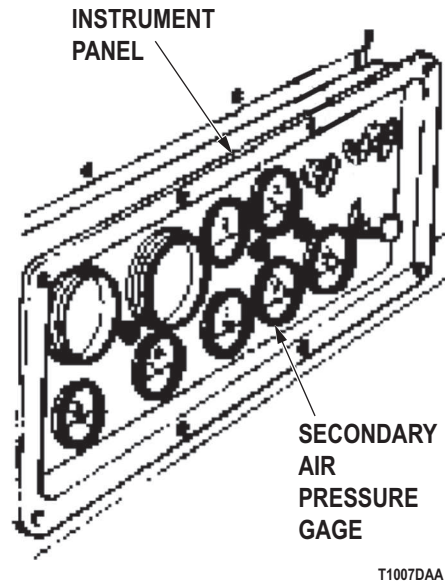

Figure 10. Air Pressure Gauge.

- b. Monitor secondary air pressure gauge on instrument panel. Refer to point to point schematics.

CONDITION/INDICATION

IS AIR AVAILABLE TO RUN THE COOLING FAN?

DECISION

NO - Perform Secondary Pressure Gauge Reads No Pressure, Low Pressure, Or Builds To Normal Operating Pressure Slowly. Primary Pressure Gauge Reads Normal troubleshooting (WP 0131).
YES - Go to Step (9).

ENGINE OVERHEATS - Continued**STEP****9. DOES FAN DRIVE CLUTCH ACTUATOR OPERATE?**

- a. Shut off engine.
- b. Allow engine to cool.
- c. Remove fan drive clutch actuator and temporarily replace with a known good actuator M939/A1 (Volume 3, WP 0447), M939A2 (Volume 3, WP 0448). Refer to point to point schematics.

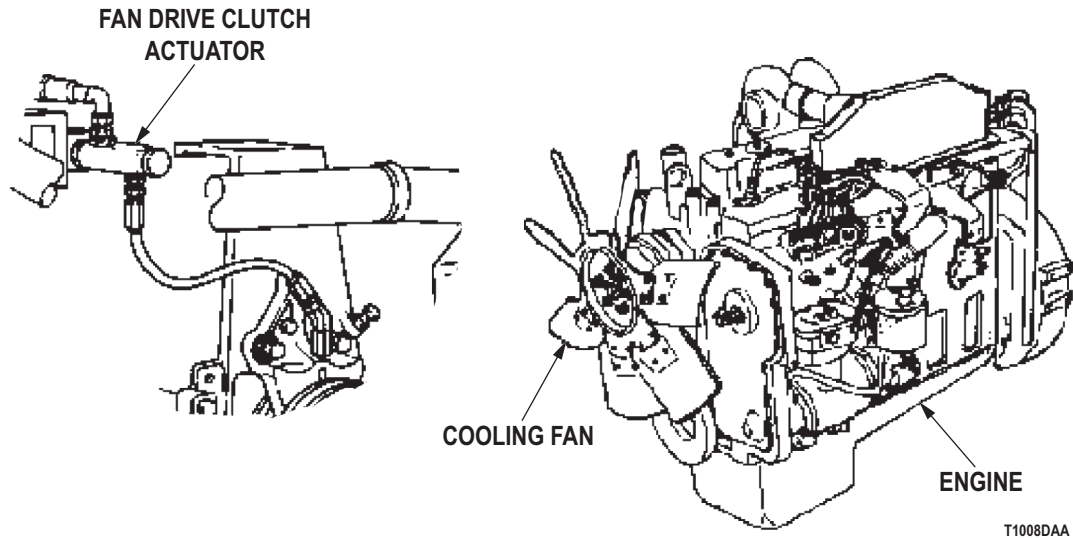

Figure 11. Fan Clutch Actuator.

- d. Start engine and bring to normal operating temperature.

NOTE

If fan operates properly, fan clutch was faulty.

- e. Check if fan operates properly.

CONDITION/INDICATION

DOES FAN DRIVE CLUTCH ACTUATOR OPERATE?

DECISION

NO - Replace fan drive clutch actuator M939/A1 (Volume 3, WP 0447), M939A2 (Volume 3, WP 0448). Go to Step (12) to verify problem is solved.
 YES - Go to Step (10).

ENGINE OVERHEATS - Continued**STEP****10. IS WATER PUMP WORKING PROPERLY AND NOT LEAKING?**

Visually check water pump for damage or leaks.

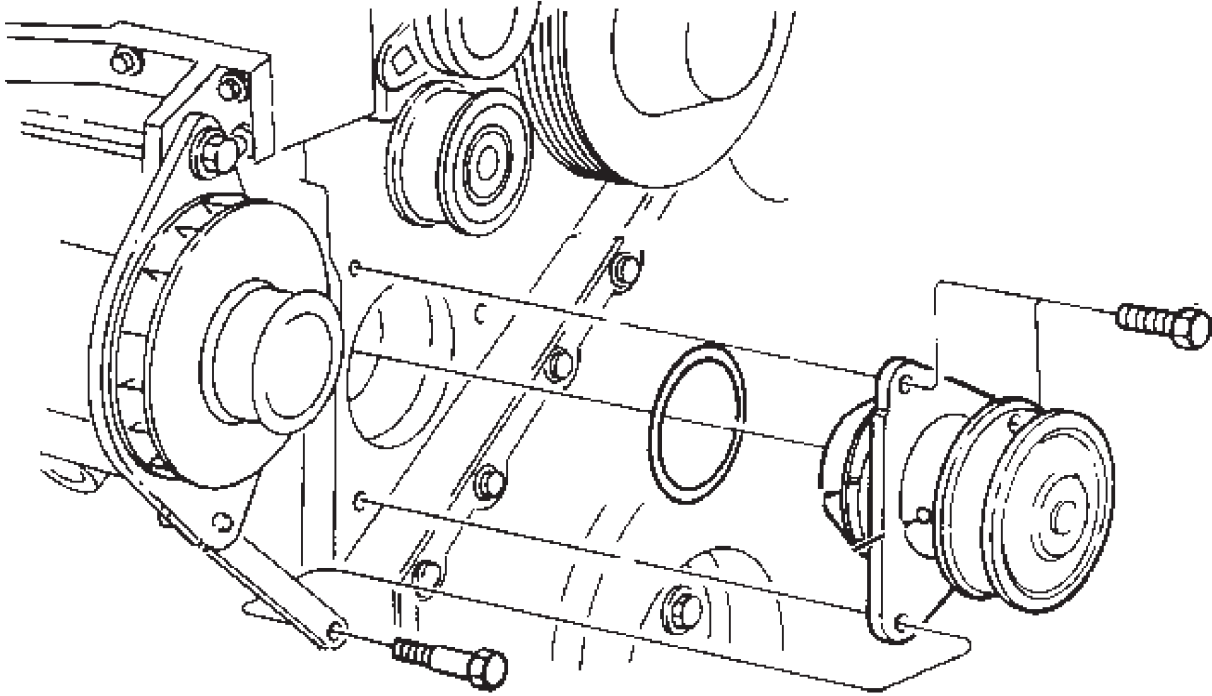

T0408DAA

Figure 12. Water Pump.

CONDITION/INDICATION

IS WATER PUMP WORKING PROPERLY AND NOT LEAKING?

DECISION

NO - Replace water pump M939/A1 (Volume 2, WP 0293), M939A2 (Volume 2, WP 0292). Go to Step (12) to verify problem is solved.

YES - Go to Step (11).

ENGINE OVERHEATS - Continued**STEP****11. IS TEMPERATURE GAUGE OPERATING PROPERLY?**

- a. Shut off engine.
- b. Remove connector from temperature sending unit on the vehicle.
- c. Turn vehicle battery switch to ON position.
- d. Connect multimeter red lead to connector removed from the temperature sending unit. Refer to point to point schematic.
- e. Connect multimeter black lead to a good ground.

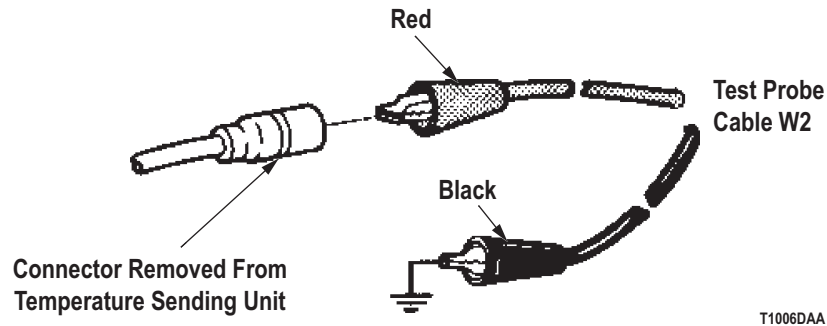

Figure 13. Test Lead Hookup.

NOTE

If meter displays a reading between 5.5 and 7.5 VDC, temperature gauge is operating correctly.

- f. Meter should display a reading between 5.5 and 7.5 VDC.

CONDITION/INDICATION

IS TEMPERATURE GAUGE OPERATING PROPERLY?

DECISION

YES - Replace temperature sending unit (Volume 2, WP 0334). Go to Step (11) to verify problem is solved.
 NO - Perform Temperature Gauge Inoperative (Coolant) troubleshooting (WP 0106).

ENGINE OVERHEATS - Continued**STEP**

12. IS YOUR ORIGINAL ENGINE OVERHEATS PROBLEM STILL PRESENT?

- a. Ensure vehicle is returned to normal operating condition.
- b. Check to see if your original engine overheats problem still exists.

CONDITION/INDICATION

IS YOUR ORIGINAL ENGINE OVERHEATS PROBLEM STILL PRESENT?

DECISION

YES - Notify supervisor.
NO - Problem fixed.

END OF WORK PACKAGE

**FIELD MAINTENANCE
LOSS OF COOLANT**

INITIAL SETUP:**Tools and Special Tools**

Tool Kit, General Mechanic's: Automotive
(Volume 5, WP 0826, Table 1, Item 56)

Personnel Required

(2)

References

Point to Point Schematics
Volume 2, WP 0229
Volume 2, WP 0233
Volume 2, WP 0249
Volume 2, WP 0280
Volume 2, WP 0281
Volume 2, WP 0284
Volume 2, WP 0285

References (cont.)

Volume 2, WP 0286
Volume 2, WP 0287
Volume 2, WP 0293
Volume 2, WP 0294
Volume 2, WP 0299
Volume 3, WP 0380
Volume 3, WP 0382
Volume 3, WP 0383
Volume 3, WP 0447
Volume 3, WP 0448

Equipment Condition

Vehicle parked and engine shut down.
(TM 9-2320-272-10)

TROUBLESHOOTING PROCEDURE
LOSS OF COOLANT**NOTE**

Conduct these malfunction tests if there is loss of coolant. This procedure will check for leaks from cooling system components, leaks or damage to transmission cooler, aftercooler leaks and leaks or damage to oil cooler.

LOSS OF COOLANT - Continued**STEP****1. ARE RADIATOR, HOSES, HOSE CONNECTIONS, AND DRAIN VALVES LEAKING?**

Visually inspect radiator, hoses, hose connections, and drain valves for leaks.

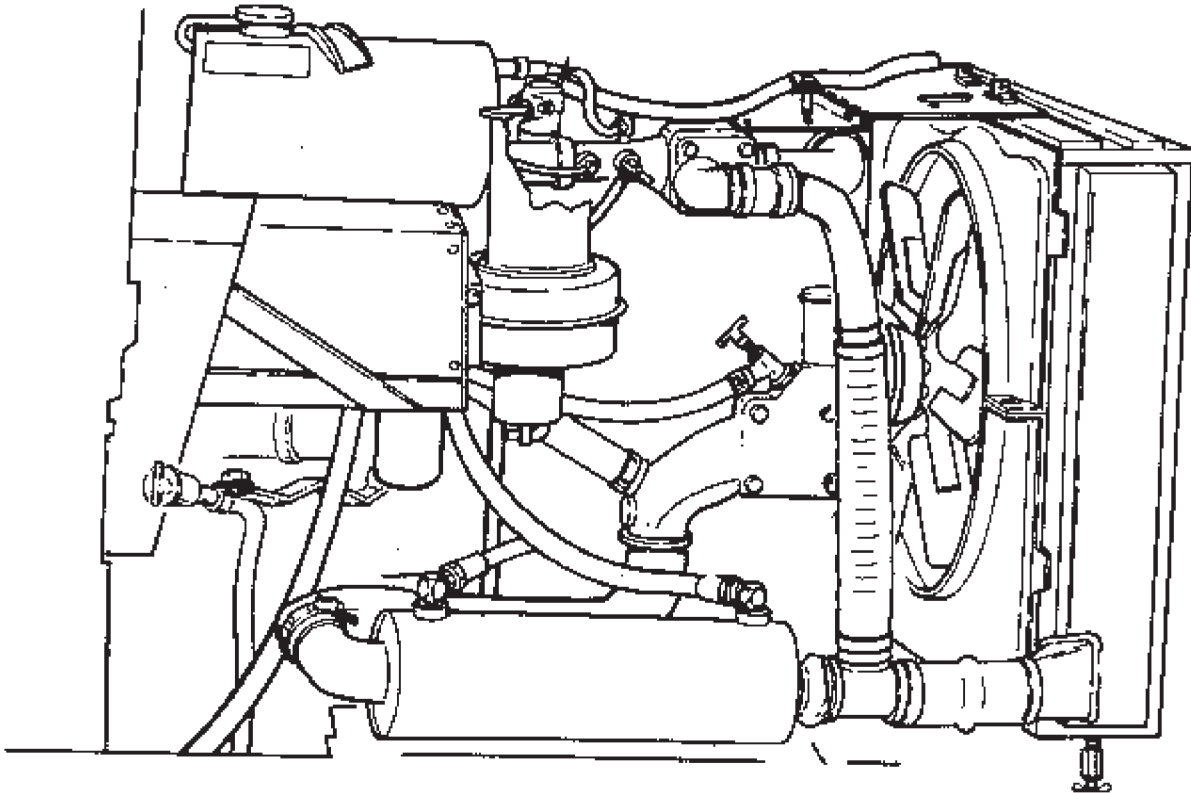

T1109DAA

Figure 1. Engine Cooling System (M939/A1).

LOSS OF COOLANT - Continued

Figure 2. Engine Cooling System (M939A2).

CONDITION/INDICATION

ARE RADIATOR, HOSES, HOSE CONNECTIONS, AND DRAIN VALVES LEAKING?

DECISION

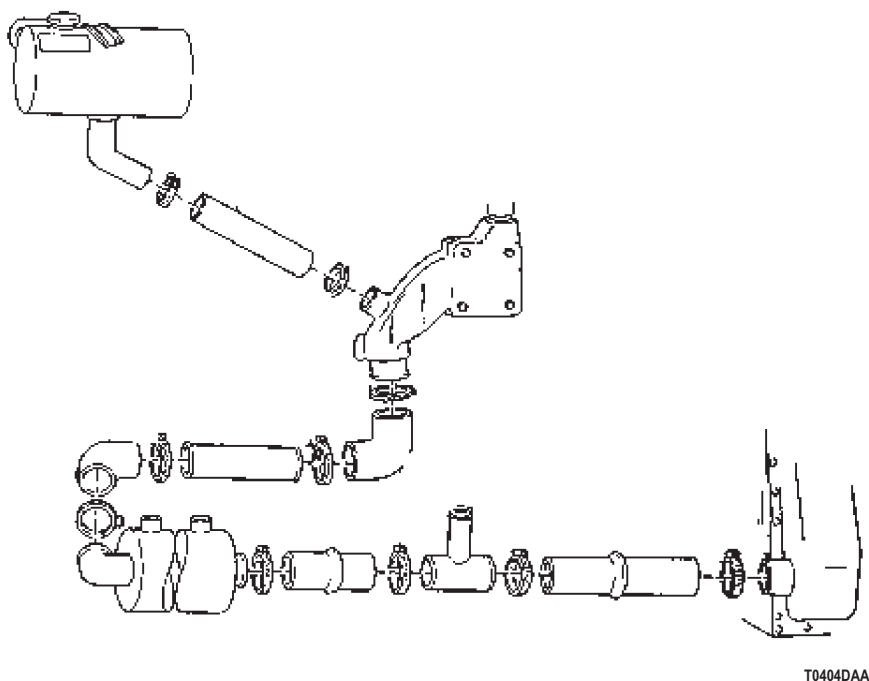
- YES - Turbocharger coolant lines leaking. Tighten or replace coolant lines (Volume 2, WP 0249). Go to Step (4) to verify problem is solved.
- YES - Coolant hoses or tubes leaking. Tighten or replace coolant hoses, clamps, or fittings M939/A1 (Volume 2, WP 0280), M939A2 (Volume 2, WP 0285). Go to Step (4) to verify problem is solved.
- YES - Aftercooler tubes leaking. Tighten or replace aftercool tube (Volume 2, WP 0299). Go to Step (4) to verify problem is solved.
- YES - Upper radiator hoses leaking. Tighten or replace upper radiator hoses (Volume 2, WP 0286). Go to Step (4) to verify problem is solved.
- YES - Radiator leaks. Replace radiator (Volume 2, WP 0281). Go to Step (4) to verify problem is solved.
- YES - Water pump leaks. Perform water pump maintenance M939/A1 (Volume 2, WP 0293), M939A2 (Volume 2, WP 0292). Go to Step (4) to verify problem is solved.
- YES - Transmission oil cooler assembly leaks. Repair or replace transmission oil cooler components (Volume 3, WP 0382). Go to Step (4) to verify problem is solved.
- YES - Air compressor coolant tube leaking. Tighten or replace coolant tube and fitting (Volume 2, WP 0284). Go to Step (4) to verify problem is solved.
- NO - Go to Step (2).

LOSS OF COOLANT - Continued**STEP**

2. IS THERE EVIDENCE OF LEAKS OR DAMAGE TO TRANSMISSION OIL COOLER?
 - a. Visually check for loose hose clamps and fittings.
 - b. Remove transmission oil dipstick and look for presence of coolant in transmission oil.

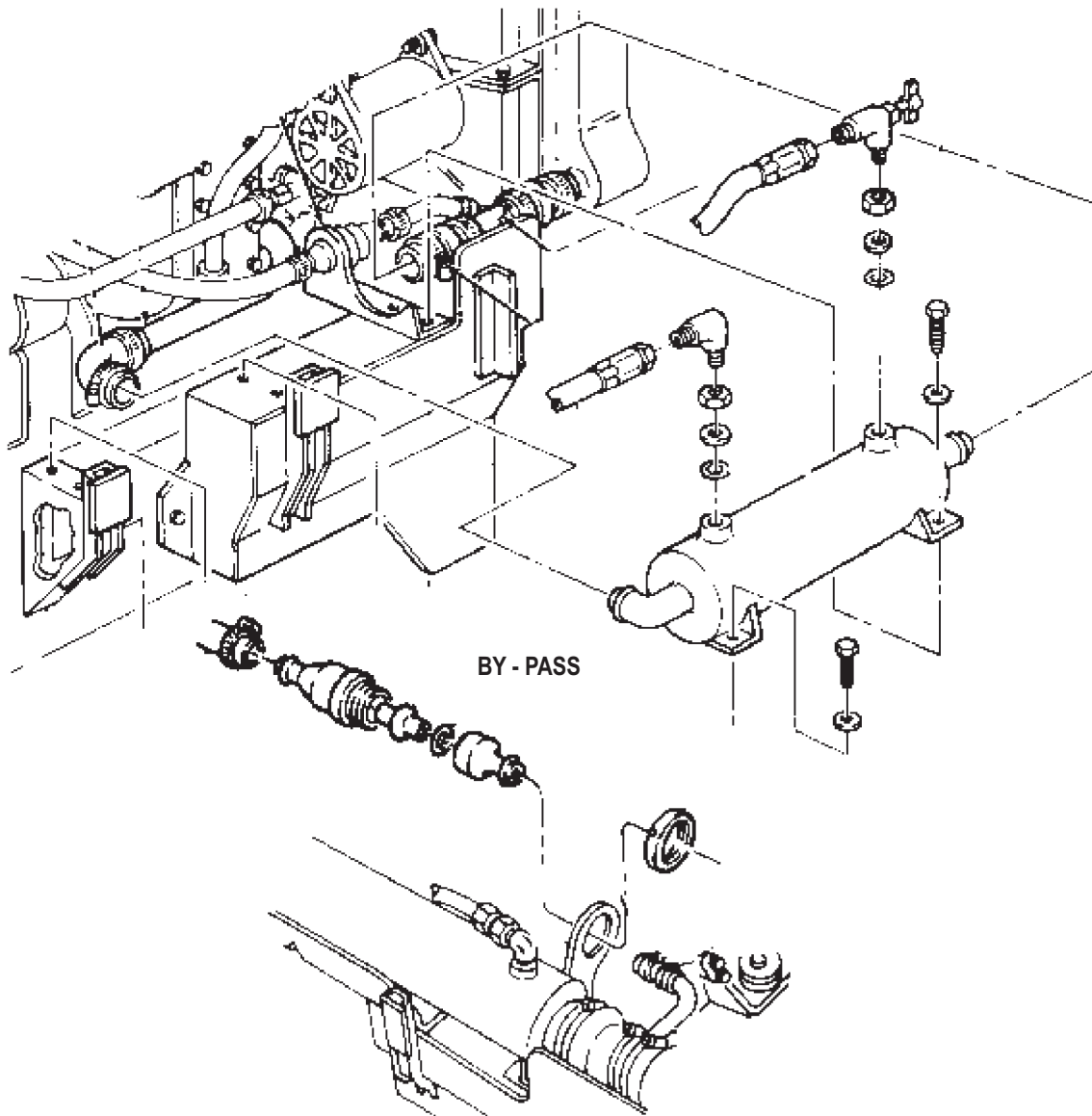

Figure 3. Transmission Oil Cooler.

- c. Check for damaged condition.

LOSS OF COOLANT - Continued**CONDITION/INDICATION**

IS THERE EVIDENCE OF LEAKS OR DAMAGE TO TRANSMISSION OIL COOLER?

DECISION

YES - Loose hoses and/or clamps. Tighten or replace hoses and clamps (Volume 3, WP 0382). Go to Step (4) to verify problem is solved.

YES - Coolant present in transmission oil. Notify supervisor. Action may not be possible at this level of maintenance.

YES - Damaged and leaking transmission oil cooler. Replace transmission oil cooler M939/A1 (Volume 3, WP 0380), M939A2 (Volume 3, WP 0383). Go to Step (4) to verify problem is solved.

NO - Go to Step (3).

LOSS OF COOLANT - Continued**STEP**

3. DO THE OIL COOLER OR AFTERCOOLER LEAK?
 - a. Check the oil cooler and aftercooler for leaks.

NOTE

During engine operation, oil pressure will be higher than coolant pressure. A leak in oil cooler will show oil in coolant. After engine is shut down, residual pressure in cooling system will cause coolant to leak into oil.

- b. Operate vehicle to normal operating temperature.

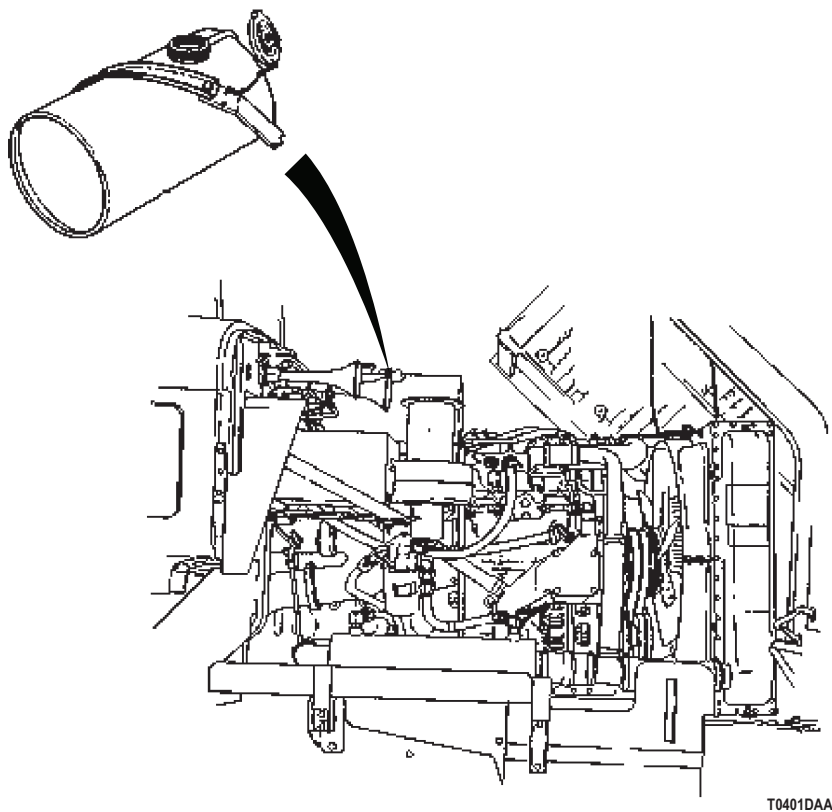

T0401DAA

Figure 4. Surge Tank.

- c. Remove oil dipstick and look for coolant in engine oil.

LOSS OF COOLANT - Continued**WARNING**

Extreme care should be taken when removing surge tank filler cap if temperature gauge reads above 175°F (79°C). Steam or hot coolant under pressure may escape rapidly or cause burns. Failure to comply may result in injury or death to personnel.

- d. Wait for engine to cool and remove surge tank filler cap, look for evidence of oil in coolant.

CONDITION/INDICATION

DO THE OIL COOLER OR AFTERCOOLER LEAK?

DECISION

YES - Coolant present in engine oil. Repair or replace aftercooler (Volume 2, WP 0299). Go to Step (4) to verify problem is solved.

YES - Oil present in coolant. Repair or replace oil cooler M939/A1 (Volume 2, WP 0233), M939A2 (Volume 2, WP 0229). Go to Step (4) to verify problem is solved.

NO - Notify supervisor. It is possible that another troubleshooting work package applies.

STEP

4. IS YOUR ORIGINAL COOLANT LOSS PROBLEM STILL PRESENT?
 - a. Ensure vehicle is returned to normal operating condition.
 - b. Check to see if your original coolant loss problem still exists.

CONDITION/INDICATION

IS YOUR ORIGINAL COOLANT LOSS PROBLEM STILL PRESENT?

DECISION

YES - Notify supervisor.

NO - Problem fixed.

END OF WORK PACKAGE

**FIELD MAINTENANCE
CONTAMINATED COOLANT**

INITIAL SETUP:**Tools and Special Tools**

Tool Kit, General Mechanic's: Automotive
(Volume 5, WP 0826, Table 1, Item 56)

Personnel Required

(2)

References

Point to Point Schematics
Volume 2, WP 0229

References (cont.)

Volume 2, WP 0233
Volume 2, WP 0287
Volume 2, WP 0299
Volume 3, WP 0382

Equipment Condition

Vehicle parked and engine shut down.
(TM 9-2320-272-10)

TROUBLESHOOTING PROCEDURE**CONTAMINATED COOLANT****NOTE**

Conduct these malfunction tests if there is evidence of contaminated coolant. This procedure will check for rust in coolant, transmission oil leaking into coolant and engine oil leaking into coolant.

CONTAMINATED COOLANT - Continued**STEP****1. WHAT TYPE OF CONTAMINATION IS PRESENT?**

- a. Check engine oil cooler, transmission oil cooler, and aftercooler for leaks.

NOTE

During engine operation, oil pressure will be higher than coolant pressure. A leak in oil cooler will show oil in coolant. After engine is shut down, residual pressure in cooling system will cause coolant to leak into oil.

- b. Operate vehicle to normal operating temperature.

WARNING

Extreme care should be taken when removing surge tank filler cap if temperature gauge reads above 175°F (79°C). Steam or hot coolant under pressure may escape rapidly or cause burns. Failure to comply may result in injury or death to personnel.

- c. Wait for engine to cool and remove surge tank filler cap.

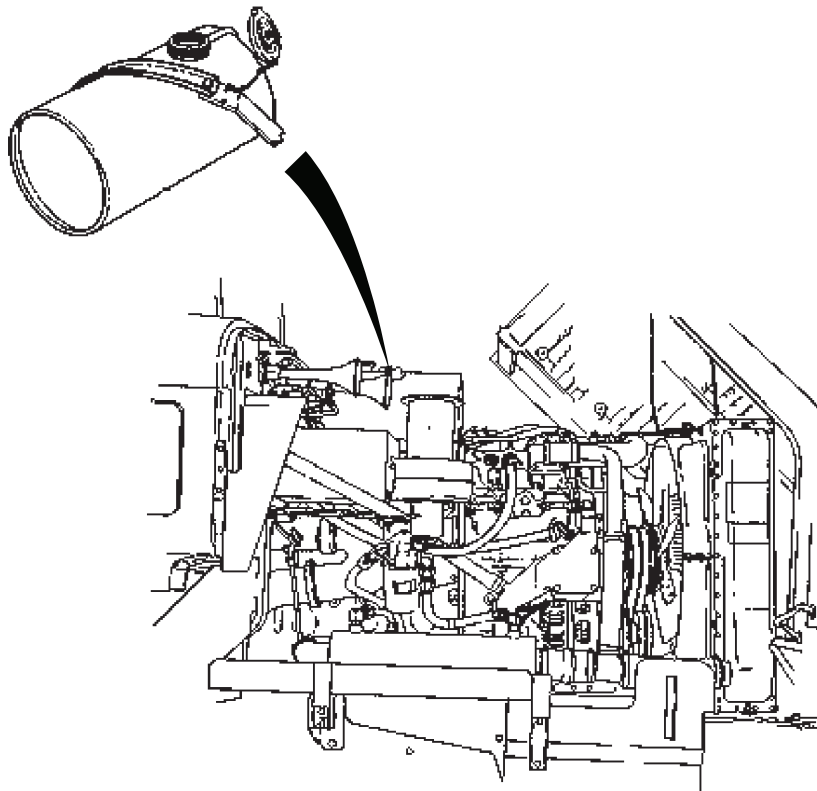

T1014DAA

Figure 1. Surge Tank.

CONTAMINATED COOLANT - Continued

- d. Inspect coolant for evidence of rust, engine oil, or transmission oil in coolant.

CONDITION/INDICATION

WHAT TYPE OF CONTAMINATION IS PRESENT?

DECISION

YES - Engine oil present in coolant. Repair or replace engine oil cooler M939/A1 (Volume 2, WP 0233), M939A2 (Volume 2, WP 0229), or aftercooler (Volume 2, WP 0299). Go to Step (2) to verify problem is solved.
YES - Transmission oil present in coolant. Repair or replace transmission oil cooler M939/A1 (Volume 3, WP 0380), M939A2 (Volume 3, WP 0383). Go to Step (2) to verify problem is solved.
YES - Evidence of rust is present in coolant. Drain and flush cooling system (Volume 2, WP 0287). Go to Step (2) to verify problem is solved.
NO - Go to Step (2) to verify problem is solved.

STEP

2. IS YOUR ORIGINAL COOLANT CONTAMINATION PROBLEM STILL PRESENT?
 - a. Ensure vehicle is returned to normal operating condition.
 - b. Check to see if your original coolant contamination problem still exists.

CONDITION/INDICATION

IS YOUR ORIGINAL COOLANT CONTAMINATION PROBLEM STILL PRESENT?

DECISION

YES - Notify supervisor.
NO - Problem fixed.

END OF WORK PACKAGE

**FIELD MAINTENANCE
EXCESSIVE NOISE DURING SHIFTING**

INITIAL SETUP:**Tools and Special Tools**

Tool Kit, General Mechanic's: Automotive
(Volume 5, WP 0826, Table 1, Item 56)

Personnel Required

(2)

References

Point to Point Schematics

References (cont.)

Volume 3, WP 0362
Volume 3, WP 0376
Volume 3, WP 0403
Volume 5, WP 0820

Equipment Condition

Vehicle parked and engine shut down.
(TM 9-2320-272-10)

TROUBLESHOOTING PROCEDURE**EXCESSIVE NOISE DURING SHIFTING****NOTE**

Conduct these malfunction tests if there is excessive noise during shifting. This procedure will check transmission fluid level, transmission fluid viscosity, and the condition of propeller shaft universal joints and propeller shaft flanges.

EXCESSIVE NOISE DURING SHIFTING - Continued**STEP****1. IS TRANSMISSION FLUID LEVEL CORRECT?**

Visually check transmission fluid level (Volume 5, WP 0820).

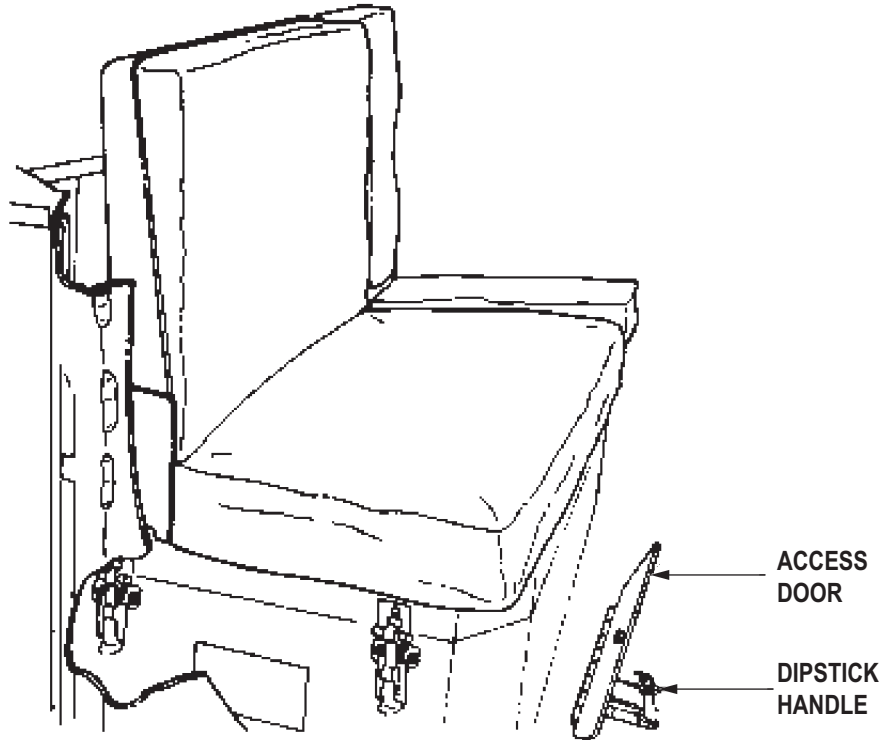

T0497DAA

Figure 1. Transmission Dipstick.

CONDITION/INDICATION

IS TRANSMISSION FLUID LEVEL CORRECT?

DECISION

YES - Go to Step (2).

NO - Add fluid as necessary (Volume 3, WP 0362). Go to Step (5) to verify problem is solved.

EXCESSIVE NOISE DURING SHIFTING - Continued**STEP****2. IS TRANSMISSION FLUID VISCOSITY CORRECT?**

Check transmission fluid viscosity (Volume 5, WP 0820).

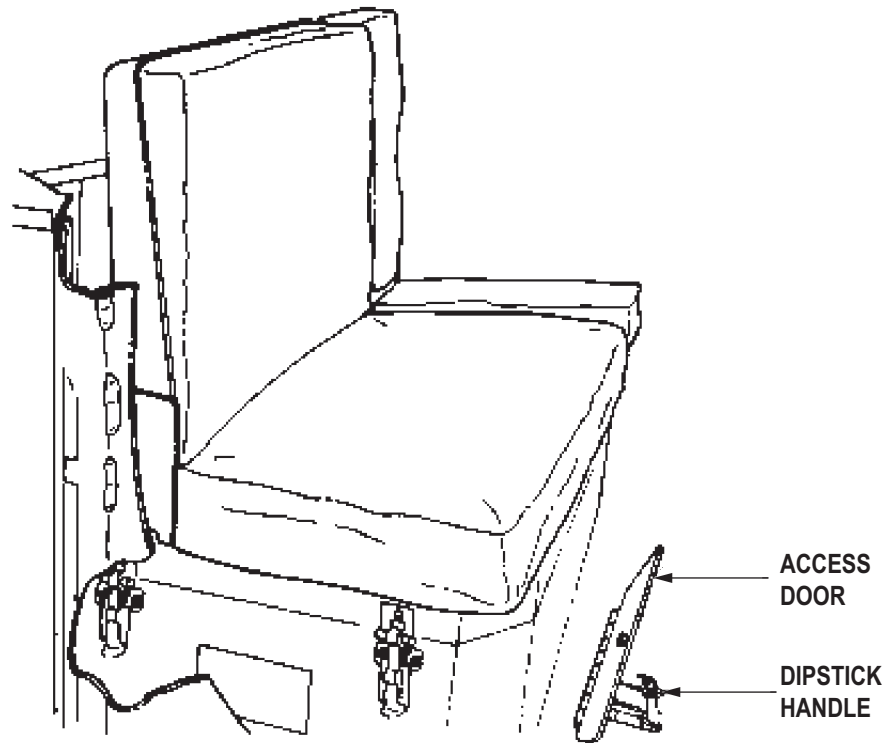

T0497DAA

Figure 2. Transmission Dipstick.

CONDITION/INDICATION

IS TRANSMISSION FLUID VISCOSITY CORRECT?

DECISION

YES - Go to Step (3).

NO - Perform transmission oil service (Volume 3, WP 0362). Go to Step (5) to verify problem is solved.

EXCESSIVE NOISE DURING SHIFTING - Continued**STEP****3. IS TRANSMISSION YOKE IN GOOD OPERATING CONDITION?**

Visually check transmission yoke for looseness, wear, and damage.

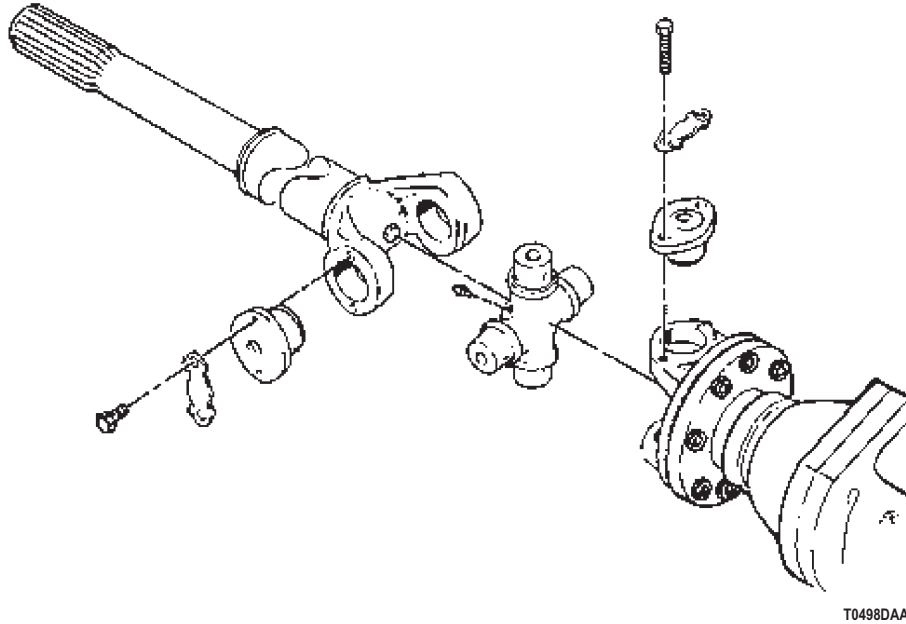

Figure 3. Transmission Yoke.

CONDITION/INDICATION

IS TRANSMISSION YOKE IN GOOD OPERATING CONDITION?

DECISION

YES - Go to Step (4).

NO - Replace transmission yoke (Volume 3, WP 0376). Go to Step (5) to verify problem is solved.

EXCESSIVE NOISE DURING SHIFTING - Continued**STEP****4. ARE PROPELLER SHAFT UNIVERSAL JOINTS IN GOOD OPERATING CONDITION?**

Visually check propeller shaft universal joints for looseness, wear, and damage.

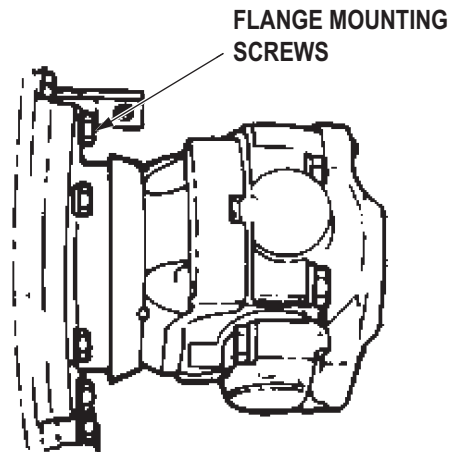

T0499DAA

Figure 4. Transmission Universal Joints.

CONDITION/INDICATION

ARE PROPELLER SHAFT UNIVERSAL JOINTS IN GOOD OPERATING CONDITION?

DECISION

YES - Go to Step (5) to verify problem is solved.

NO - Replace universal joint (Volume 3, WP 0403). Go to Step (5) to verify problem is solved.

STEP**5. IS YOUR ORIGINAL PROBLEM STILL PRESENT?**

a. Ensure vehicle is returned to normal operating condition.

b. Check to see if your original problem still exists.

CONDITION/INDICATION

IS YOUR ORIGINAL PROBLEM STILL PRESENT?

DECISION

YES - Notify supervisor.

NO - Problem fixed.

END OF WORK PACKAGE

**FIELD MAINTENANCE
LOW TRANSMISSION OIL PRESSURE**

INITIAL SETUP:**Tools and Special Tools**

Tool Kit, General Mechanic's: Automotive
(Volume 5, WP 0826, Table 1, Item 56)

References (cont.)

Volume 3, WP 0362
Volume 5, WP 0820

Personnel Required

(2)

Equipment Condition

Vehicle parked and engine shut down.
(TM 9-2320-272-10)

References

Point to Point Schematics

TROUBLESHOOTING PROCEDURE**LOW TRANSMISSION OIL PRESSURE****NOTE**

Conduct these malfunction tests if transmission oil pressure is low. This procedure will check transmission fluid level and the transmission oil filter.

LOW TRANSMISSION OIL PRESSURE - Continued**STEP****1. IS TRANSMISSION FLUID LEVEL CORRECT?**

Visually check transmission fluid level (Volume 5, WP 0820) .

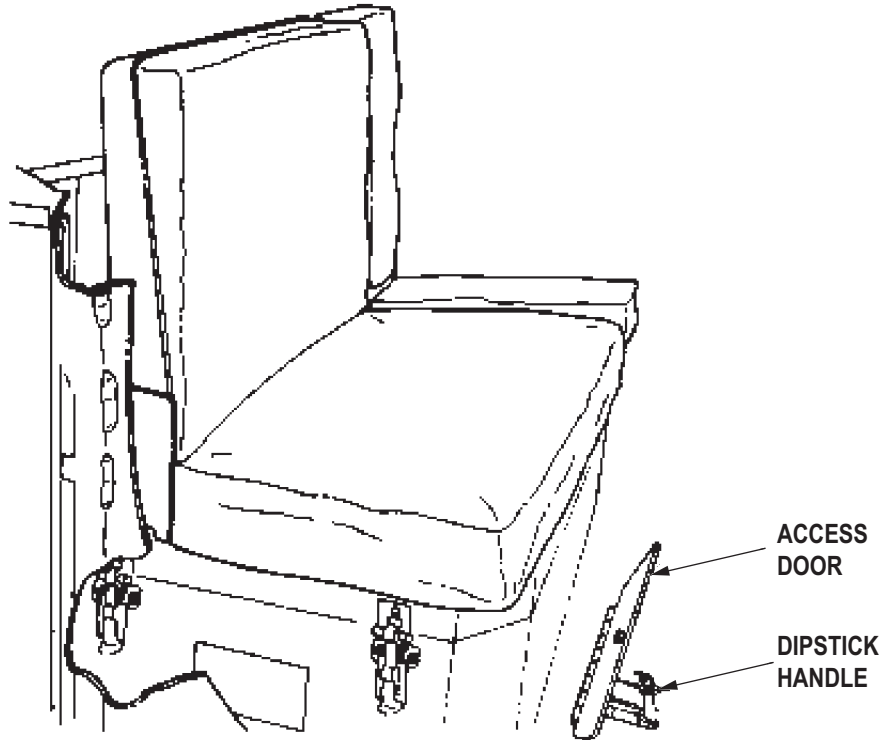

T0985DAA

Figure 1. Transmission Dipstick.

CONDITION/INDICATION

IS TRANSMISSION FLUID LEVEL CORRECT?

DECISION

YES - Replace transmission oil filter (Volume 3, WP 0362). Go to Step (2) to verify problem is solved.
NO - Add fluid as necessary (Volume 3, WP 0362). Go to Step (2) to verify problem is solved.

LOW TRANSMISSION OIL PRESSURE - Continued**STEP**

2. IS YOUR ORIGINAL PROBLEM STILL PRESENT?
 - a. Ensure vehicle is returned to normal operating condition.
 - b. Check to see if your original problem still exists.

CONDITION/INDICATION

IS YOUR ORIGINAL PROBLEM STILL PRESENT?

DECISION

YES - Notify supervisor.
NO - Problem fixed.

END OF WORK PACKAGE

**FIELD MAINTENANCE
TRANSMISSION OIL LEAKING**

INITIAL SETUP:**Tools and Special Tools**

Tool Kit, General Mechanic's: Automotive
(Volume 5, WP 0826, Table 1, Item 56)

Personnel Required

(2)

References

Point to Point Schematics
Volume 3, WP 0362

References (cont.)

Volume 3, WP 0363
Volume 3, WP 0377
Volume 3, WP 0381
Volume 3, WP 0382

Equipment Condition

Vehicle parked and engine shut down.
(TM 9-2320-272-10)

TROUBLESHOOTING PROCEDURE**TRANSMISSION OIL LEAKING****NOTE**

Conduct these malfunction tests if there is transmission oil leakage. This procedure will check the drain plug, oil pan gasket and mounting bolts, dipstick tube connection, transmission housing, oil cooler oil filter, and oil cooler hoses.

TRANSMISSION OIL LEAKING - Continued**STEP****1. IS THE TRANSMISSION OIL PAN LEAKING OIL?**

Visually inspect for loose or damaged drain plug or mounting bolts, gasket damage, dipstick tube connection or transmission housing leaks.

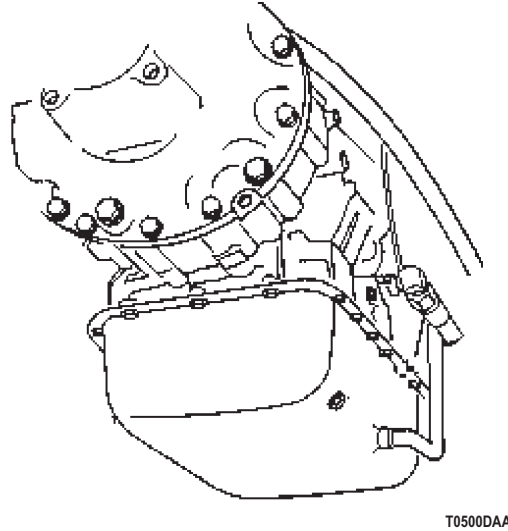

T0500DAA

Figure 1. Transmission Oil Pan.

CONDITION/INDICATION

IS THE TRANSMISSION OIL PAN LEAKING OIL?

DECISION

YES - Oil pan drain plug leaking. Tighten oil pan drain plug (Volume 3, WP 0362). Go to Step (3) to verify problem is solved.

YES - Leaks at oil pan mounting bolts. Tighten oil pan mounting bolts (Volume 3, WP 0377). Go to Step (3) to verify problem is solved.

YES - Oil pan gasket leaking. Replace oil pan gasket (Volume 3, WP 0377). Go to Step (3) to verify problem is solved.

YES - Oil dipstick tube leaking. Tighten dipstick tube connection (Volume 3, WP 0363). Go to Step (3) to verify problem is solved.

YES - Transmission housing leaking. Notify supervisor. Action may not be possible at this level of maintenance.

NO - Go to Step (2).

TRANSMISSION OIL LEAKING - Continued**STEP****2. IS TRANSMISSION OIL LEAKING FROM TRANSMISSION OIL COOLER SYSTEM?**

Visually inspect for loose or damaged oil cooler, oil filter, and oil cooler hoses.

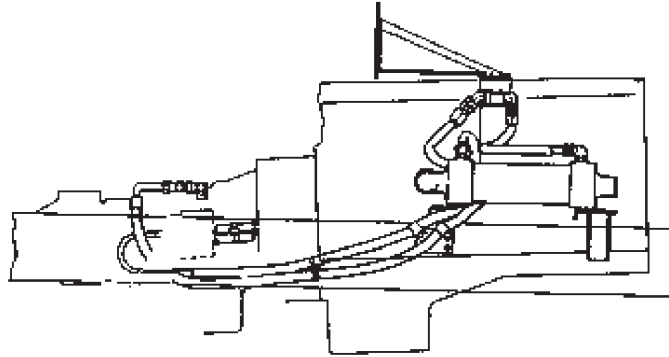

T0501DAA

Figure 2. Transmission Oil Cooling Lines.

CONDITION/INDICATION

IS TRANSMISSION OIL LEAKING FROM TRANSMISSION OIL COOLER SYSTEM?

DECISION

YES - Oil cooler filter leaking. Tighten or replace oil filter (Volume 3, WP 0381). Go to Step (3) to verify problem is solved.

YES - Oil cooler hose(s) leaking. Tighten or replace hose(s) (Volume 3, WP 0382). Go to Step (3) to verify problem is solved.

NO - Go to Step (3) to verify problem is solved.

STEP**3. IS YOUR ORIGINAL PROBLEM STILL PRESENT?**

a. Ensure vehicle is returned to normal operating condition.

b. Check to see if your original problem still exists.

CONDITION/INDICATION

IS YOUR ORIGINAL PROBLEM STILL PRESENT?

DECISION

YES - Notify supervisor.

NO - Problem fixed.

END OF WORK PACKAGE

**FIELD MAINTENANCE
NO RESPONSE TO SHIFT LEVER MOVEMENT**

INITIAL SETUP:**Tools and Special Tools**

Tool Kit, General Mechanic's: Automotive
(Volume 5, WP 0826, Table 1, Item 56)

References (cont.)

Volume 3, WP 0362
Volume 3, WP 0369
Volume 5, WP 0820

Personnel Required

(2)

Equipment Condition

Vehicle parked and engine shut down.
(TM 9-2320-272-10)

References

Point to Point Schematics

TROUBLESHOOTING PROCEDURE**NO RESPONSE TO SHIFT LEVER MOVEMENT****NOTE**

Conduct these malfunction tests if there is no response to shift lever movement. This procedure will check transmission fluid level and the selector lever assembly linkage.

NO RESPONSE TO SHIFT LEVER MOVEMENT - Continued**STEP****1. IS TRANSMISSION FLUID LEVEL CORRECT?**

Visually check transmission fluid level (Volume 5, WP 0820).

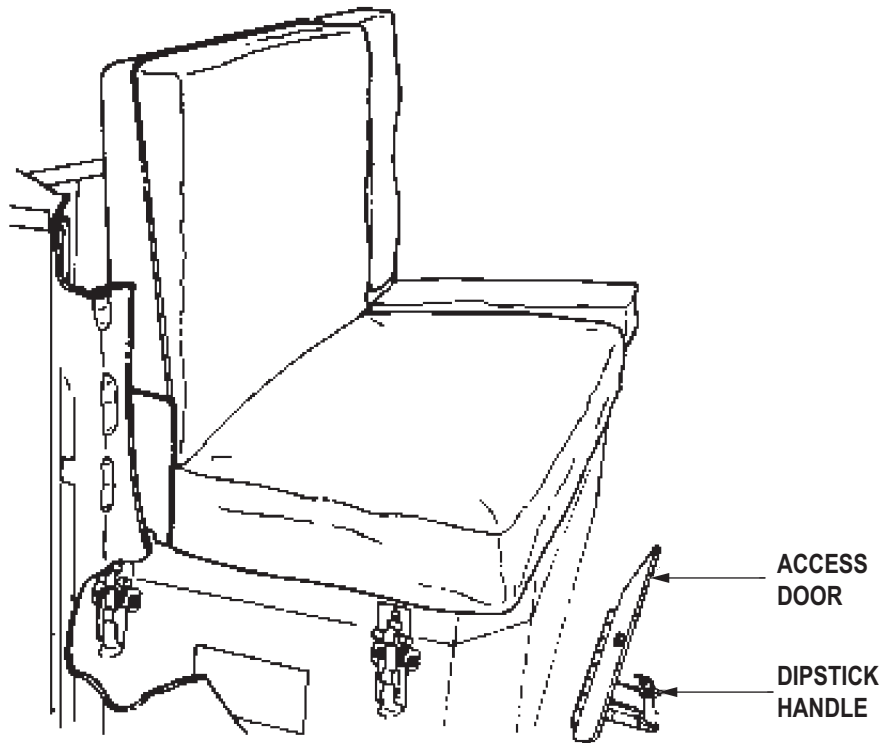

T1040DAA

Figure 1. Transmission Dipstick.

CONDITION/INDICATION

IS TRANSMISSION FLUID LEVEL CORRECT?

DECISION

NO - Add fluid as necessary (Volume 3, WP 0362). Go to Step (5) to verify problem is solved.
YES - Go to Step (2).

NO RESPONSE TO SHIFT LEVER MOVEMENT - Continued**STEP**

2. IS TRANSMISSION SELECTOR LEVER LINKAGE ATTACHING HARDWARE LOOSE, DAMAGED, OR MISSING?

Visually inspect transmission selector lever linkage for loose, damaged, or missing hardware.

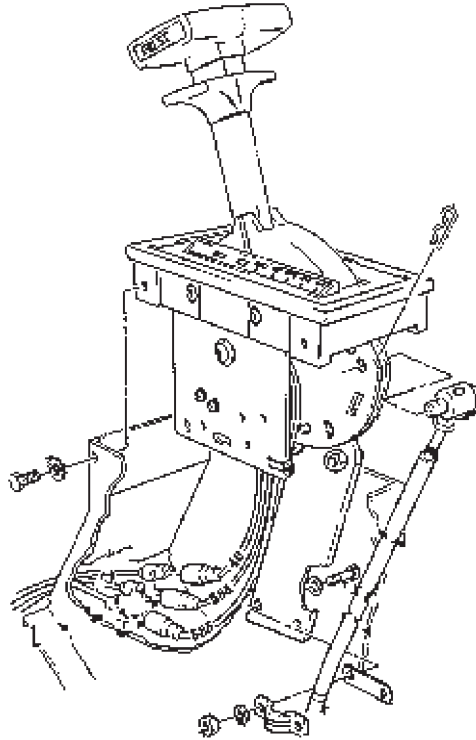

T1042DAA

Figure 2. Transmission Selector.

CONDITION/INDICATION

IS TRANSMISSION SELECTOR LEVER LINKAGE ATTACHING HARDWARE LOOSE, DAMAGED, OR MISSING?

DECISION

YES - Repair transmission selector lever linkage (Volume 3, WP 0369). Go to Step (3) to verify problem is solved.

NO - Go to Step (3) to verify problem is solved.

NO RESPONSE TO SHIFT LEVER MOVEMENT - Continued**STEP**

3. IS YOUR ORIGINAL PROBLEM STILL PRESENT?
 - a. Ensure vehicle is returned to normal operating condition.
 - b. Check to see if your original problem still exists.

CONDITION/INDICATION

IS YOUR ORIGINAL PROBLEM STILL PRESENT?

DECISION

YES - Notify supervisor.
NO - Problem fixed.

END OF WORK PACKAGE

**FIELD MAINTENANCE
ROUGH SHIFTING**

INITIAL SETUP:**Tools and Special Tools**

Tool Kit, General Mechanic's: Automotive
(Volume 5, WP 0826, Table 1, Item 56)

References (cont.)

Volume 3, WP 0362
Volume 3, WP 0369
Volume 5, WP 0820

Personnel Required

(2)

Equipment Condition

Vehicle parked and engine shut down.
(TM 9-2320-272-10)

References

Point to Point Schematics

TROUBLESHOOTING PROCEDURE**ROUGH SHIFTING****NOTE**

Conduct these malfunction tests if shifting is rough. This procedure will check transmission fluid level and the selector lever assembly linkage.

ROUGH SHIFTING - Continued**STEP****1. IS TRANSMISSION FLUID LEVEL CORRECT?**

Visually check transmission fluid level (Volume 5, WP 0820).

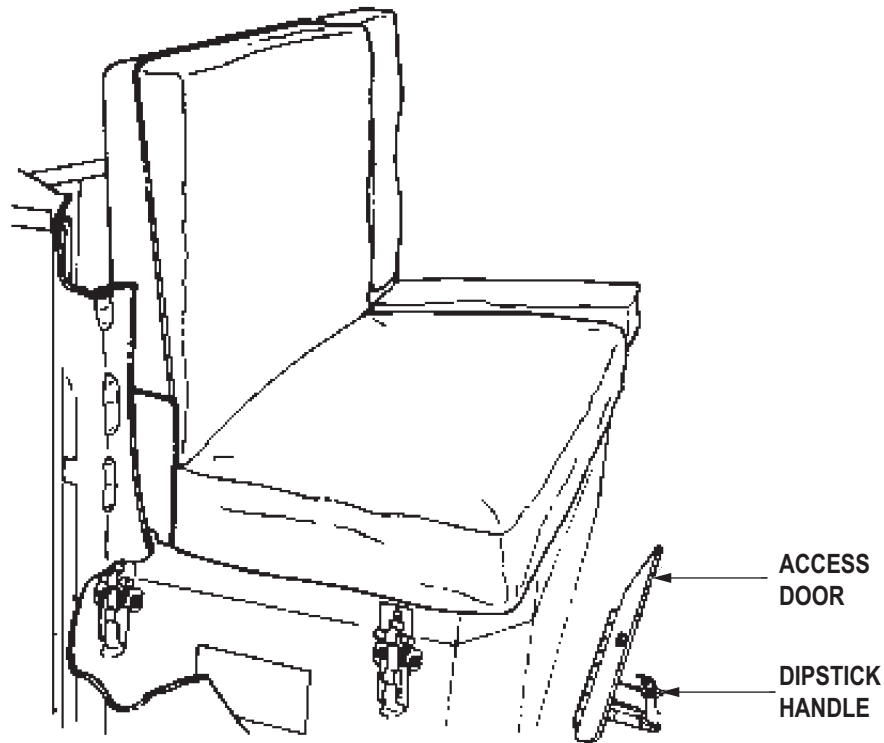

T1041DAA

Figure 1. Transmission Dipstick.

CONDITION/INDICATION

IS TRANSMISSION FLUID LEVEL CORRECT?

DECISION

NO - Add fluid as necessary (Volume 3, WP 0362). Go to Step (5) to verify problem is solved.
YES - Go to Step (2).

ROUGH SHIFTING - Continued**STEP**

2. IS TRANSMISSION SELECTOR LEVER LINKAGE ATTACHING HARDWARE LOOSE, DAMAGED, OR MISSING?

Visually inspect transmission selector lever linkage for loose, damaged, or missing hardware.

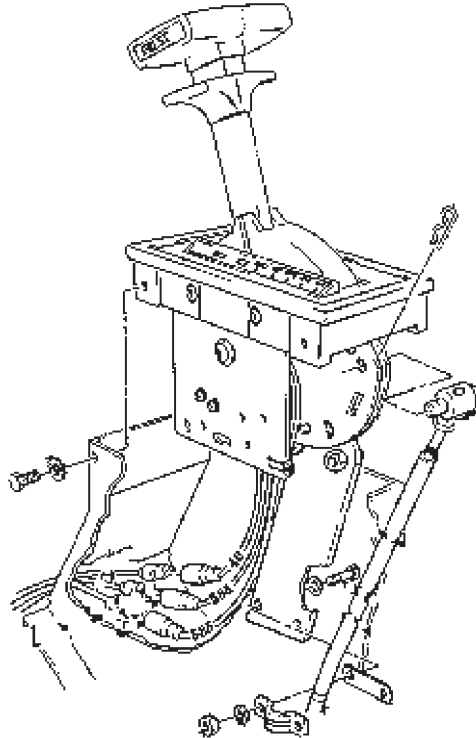

T0504DAA

Figure 2. Transmission Selector.

CONDITION/INDICATION

IS TRANSMISSION SELECTOR LEVER LINKAGE ATTACHING HARDWARE LOOSE, DAMAGED, OR MISSING?

DECISION

YES - Repair transmission selector lever linkage (Volume 3, WP 0369). Go to Step (3) to verify problem is solved.

NO - Go to Step (3) to verify problem is solved.

ROUGH SHIFTING - Continued**STEP**

3. IS YOUR ORIGINAL PROBLEM STILL PRESENT?
 - a. Ensure vehicle is returned to normal operating condition.
 - b. Check to see if your original problem still exists.

CONDITION/INDICATION

IS YOUR ORIGINAL PROBLEM STILL PRESENT?

DECISION

YES - Notify supervisor.
NO - Problem fixed.

END OF WORK PACKAGE

FIELD MAINTENANCE
TRANSMISSION OVERHEATS AS INDICATED BY TRANSMISSION TEMPERATURE GAUGE

INITIAL SETUP:**Tools and Special Tools**

Tool Kit, General Mechanic's: Automotive
(Volume 5, WP 0826, Table 1, Item 56)
Multimeter
(Volume 5, WP 0826, Table 1, Item 34)
Test Set, Electronic Systems
(Volume 5, WP 0826, Table 1, Item 51)

References (cont.)

Volume 2, WP 0341
Volume 3, WP 0362
Volume 5, WP 0820

Equipment Condition

Vehicle parked and engine shut down.
(TM 9-2320-272-10)

Personnel Required

(2)

References

Point to Point Schematics

TROUBLESHOOTING PROCEDURE**TRANSMISSION OVERHEATS AS INDICATED BY TRANSMISSION TEMPERATURE GAUGE****NOTE**

Conduct these malfunction tests if transmission temperature gauge indicates the transmission is overheating. This procedure will check the transmission fluid level and transmission temperature gauge.

TRANSMISSION OVERHEATS AS INDICATED BY TRANSMISSION TEMPERATURE GAUGE - Continued**STEP****1. IS TRANSMISSION FLUID LEVEL CORRECT?**

Visually check transmission fluid level (Volume 5, WP 0820).

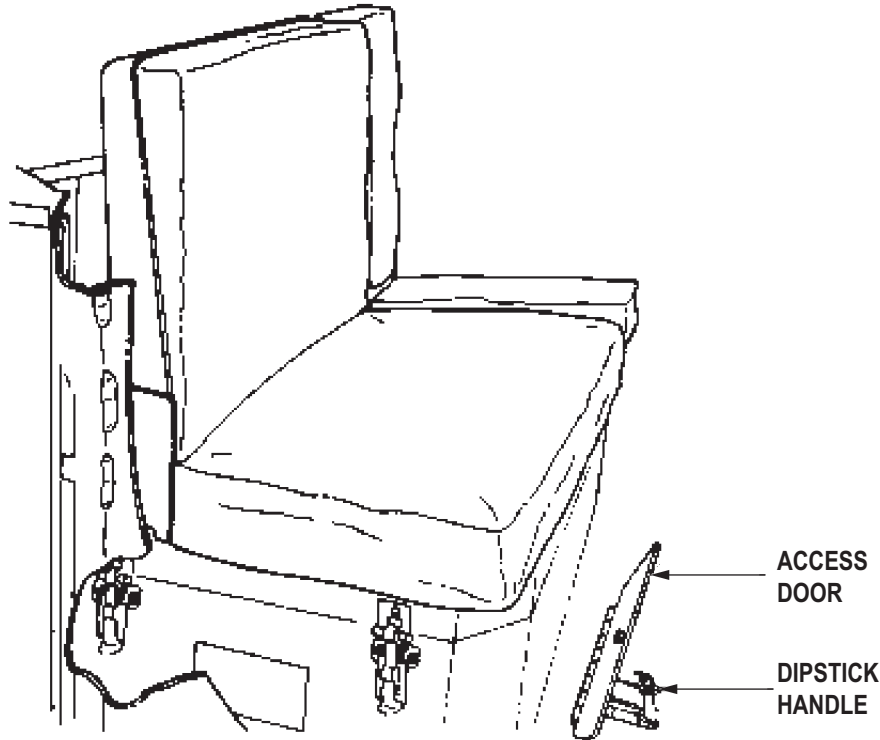

T1004DAA

Figure 1. Transmission Dipstick.

CONDITION/INDICATION

IS TRANSMISSION FLUID LEVEL CORRECT?

DECISION

YES - Go to Step (2).

NO - Add fluid as necessary (Volume 3, WP 0362). Go to Step (3) to verify problem is solved.

STEP**2. IS TRANSMISSION TEMPERATURE GAUGE OPERATING PROPERLY?**

- a. Turn battery switch to OFF position.
- b. Remove connector from temperature sending unit on the vehicle.
- c. Turn battery switch to ON position.
- d. Turn start switch to RUN position.
- e. Set multimeter to measure VDC.

TRANSMISSION OVERHEATS AS INDICATED BY TRANSMISSION TEMPERATURE GAUGE - Continued

Figure 2. Test Lead Hookup.

- f. Connect multimeter red lead to connector removed from the temperature sending unit. Refer to point to point schematics.
- g. Connect multimeter black lead to a good ground.

NOTE

If meter displays a reading between 22 and 26 VDC, temperature gauge is operating correctly.

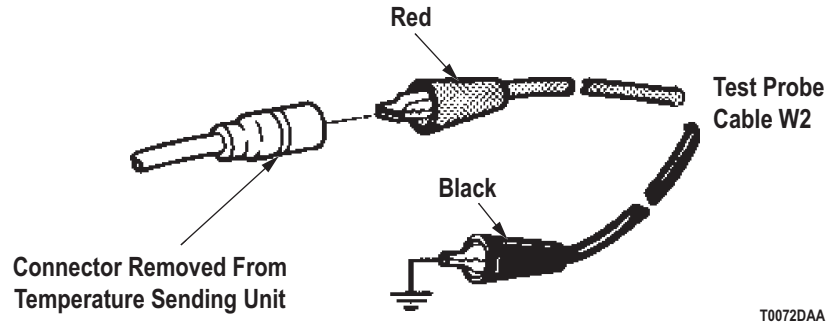
- h. Meter reading should be between 22 and 26 VDC.

CONDITION/INDICATION

IS TRANSMISSION TEMPERATURE GAUGE OPERATING PROPERLY?

DECISION

YES - Replace temperature sending unit (Volume 2, WP 0341). Go to Step (3) to verify problem is solved.
 NO - Perform Transmission Temperature Gauge Inoperative troubleshooting (WP 0105).

STEP

3. IS YOUR ORIGINAL TRANSMISSION OVERHEATING PROBLEM STILL PRESENT?
 - a. Ensure vehicle is returned to normal operating condition.
 - b. Check to see if your original transmission overheating problem still exists.

CONDITION/INDICATION

IS YOUR ORIGINAL TRANSMISSION OVERHEATING PROBLEM STILL PRESENT?

DECISION

YES - Notify supervisor.
 NO - Problem fixed.

END OF WORK PACKAGE

**FIELD MAINTENANCE
DIRT OR METAL PARTICLES IN TRANSMISSION OIL**

INITIAL SETUP:**Tools and Special Tools**

Tool Kit, General Mechanic's: Automotive
(Volume 5, WP 0826, Table 1, Item 56)

References (cont.)

Volume 3, WP 0362
Volume 5, WP 0820

Personnel Required

(2)

Equipment Condition

Vehicle parked and engine shut down.
(TM 9-2320-272-10)

References

Point to Point Schematics

TROUBLESHOOTING PROCEDURE**DIRT OR METAL PARTICLES IN TRANSMISSION OIL****NOTE**

Conduct these malfunction tests if there is dirt or metal particles in the oil. This procedure will check transmission oil for contamination.

DIRT OR METAL PARTICLES IN TRANSMISSION OIL - Continued**STEP****1. DOES OIL SAMPLE TEST INDICATE OIL IS CONTAMINATED?**

Submit oil sample for testing (Volume 5, WP 0820).

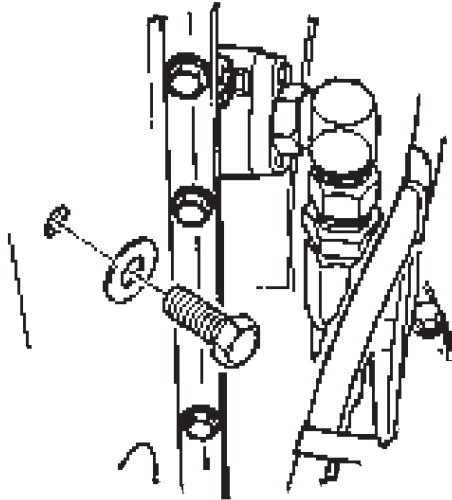

T0507DAA

Figure 1. Transmission Oil Sample Port.

CONDITION/INDICATION

DOES OIL SAMPLE TEST INDICATE OIL IS CONTAMINATED?

DECISION

YES - Dirt in oil. Service transmission (Volume 3, WP 0362). Go to Step (2) to verify problem is solved.

YES - Metal in oil. Notify supervisor. Action may not be possible at this level of maintenance.

NO - Go to Step (2) to verify problem is solved.

STEP**2. IS YOUR ORIGINAL DIRT OR METAL PARTICLES IN OIL PROBLEM STILL PRESENT?**

- a. Ensure vehicle is returned to normal operating condition.
- b. Check to see if your original dirt or metal particles in oil problem still exists.

CONDITION/INDICATION

IS YOUR ORIGINAL DIRT OR METAL PARTICLES IN OIL PROBLEM STILL PRESENT?

DECISION

YES - Notify supervisor.

NO - Problem fixed.

END OF WORK PACKAGE

FIELD MAINTENANCE
OIL THROWN FROM TRANSMISSION DIPSTICK TUBE

INITIAL SETUP:**Tools and Special Tools**

Tool Kit, General Mechanic's: Automotive
(Volume 5, WP 0826, Table 1, Item 56)

References (cont.)

Volume 3, WP 0362
Volume 3, WP 0363
Volume 5, WP 0820

Personnel Required

(2)

Equipment Condition

Vehicle parked and engine shut down.
(TM 9-2320-272-10)

References

Point to Point Schematics

TROUBLESHOOTING PROCEDURE**OIL THROWN FROM TRANSMISSION DIPSTICK TUBE****NOTE**

Conduct these malfunction tests if oil is thrown from the filler tube. This procedure will check the transmission oil level and that the dipstick is tight in the filler tube.

OIL THROWN FROM TRANSMISSION DIPSTICK TUBE - Continued**STEP****1. IS TRANSMISSION OIL LEVEL TOO HIGH?**

Visually check transmission fluid level (Volume 5, WP 0820).

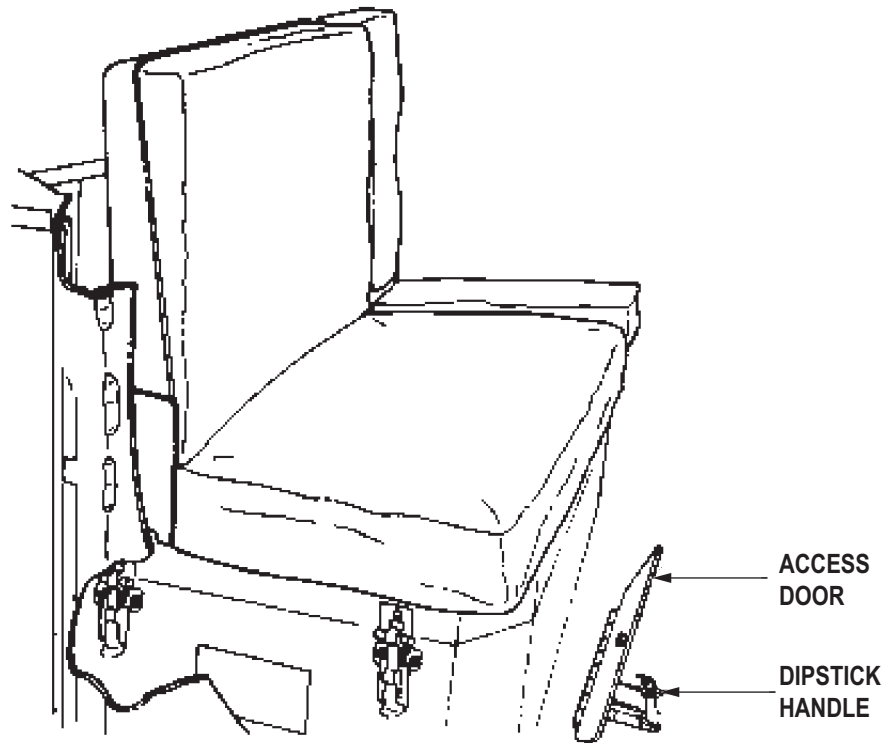

T0986DAA

Figure 1. Transmission Dipstick.

CONDITION/INDICATION

IS TRANSMISSION OIL LEVEL TOO HIGH?

DECISION

YES - Drain oil to correct level (Volume 3, WP 0362). Go to Step (2) to verify problem is solved.
NO - Go to Step (2).

OIL THROWN FROM TRANSMISSION DIPSTICK TUBE - Continued**STEP****2. IS DIPSTICK LOOSE?**

Check dipstick to ensure it is not loose.

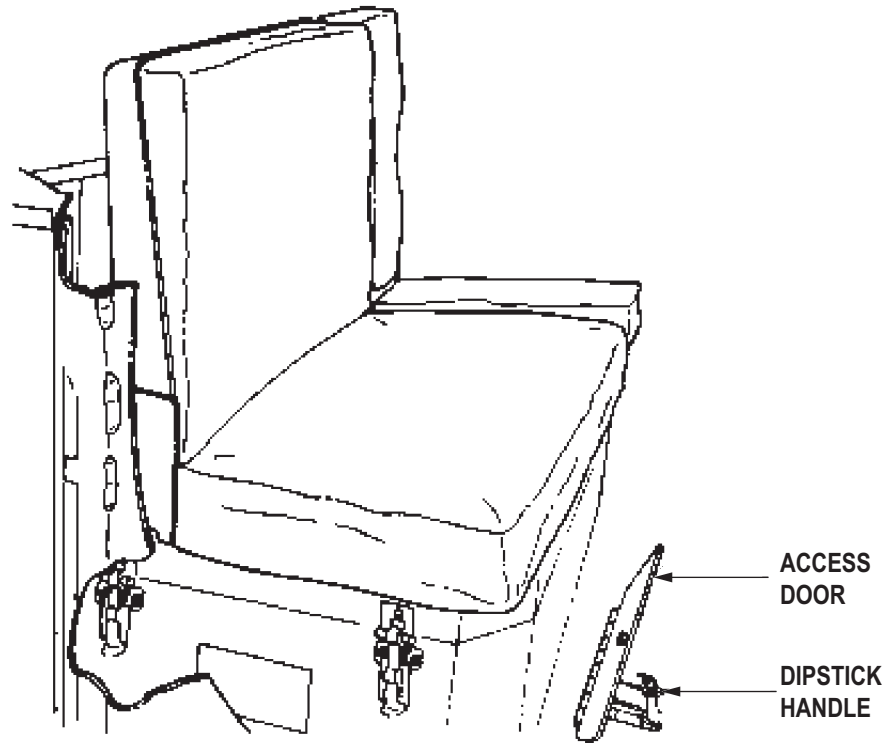

T0986DAA

Figure 2. Transmission Dipstick.

CONDITION/INDICATION

IS DIPSTICK LOOSE?

DECISION

YES - Tighten dipstick (Volume 3, WP 0363). Go to Step (3) to verify problem is solved.
NO - Go to Step (3) to verify problem is solved.

OIL THROWN FROM TRANSMISSION DIPSTICK TUBE - Continued**STEP**

3. IS YOUR ORIGINAL OIL THROWN FROM FILLER TUBE PROBLEM STILL PRESENT?
 - a. Ensure vehicle is returned to normal operating condition.
 - b. Check to see if your original oil thrown from filler tube problem still exists.

CONDITION/INDICATION

IS YOUR ORIGINAL OIL THROWN FROM FILLER TUBE PROBLEM STILL PRESENT?

DECISION

YES - Notify Supervisor.
NO - Problem Fixed.

END OF WORK PACKAGE

**FIELD MAINTENANCE
TRANSMISSION OIL DIRTY, FOAMY, AND/OR MILKY**

INITIAL SETUP:**Tools and Special Tools**

Tool Kit, General Mechanic's: Automotive
(Volume 5, WP 0826, Table 1, Item 56)

Personnel Required

(2)

References

Point to Point Schematics
WP 0029

References (cont.)

WP 0037
Volume 3, WP 0362
Volume 3, WP 0363
Volume 5, WP 0820

Equipment Condition

Vehicle parked and engine shut down.
(TM 9-2320-272-10)

TROUBLESHOOTING PROCEDURE**TRANSMISSION OIL DIRTY, FOAMY, AND/OR MILKY****NOTE**

Conduct these tests if transmission oil is dirty, foamy, and/or milky. Dirt/grit in oil indicates oil needs to be changed. Foaming indicates contamination by air or water. Milky oil indicates contamination by coolant.

TRANSMISSION OIL DIRTY, FOAMY, AND/OR MILKY - Continued**STEP****1. IS TRANSMISSION DIPSTICK DAMAGED OR LEAKING?**

Check transmission dipstick for damage and leaks.

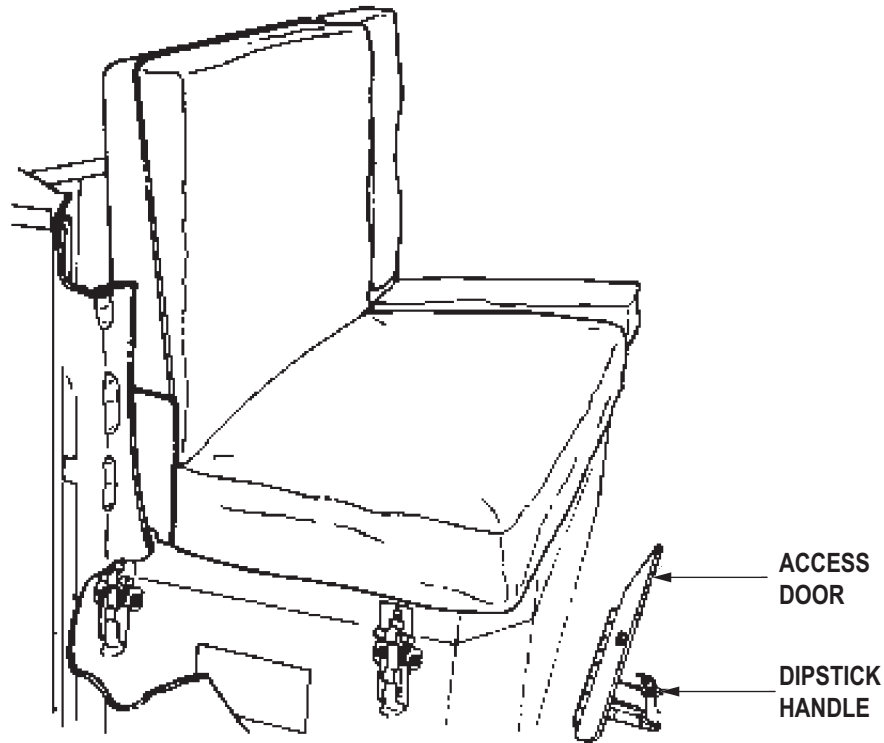

T1018DAA

Figure 1. Transmission Dipstick.

CONDITION/INDICATION

IS TRANSMISSION DIPSTICK DAMAGED OR LEAKING?

DECISION

YES - Repair transmission dipstick (Volume 3, WP 0363). Go to Step (5) to verify problem is solved.
NO - Go to Step (2).

TRANSMISSION OIL DIRTY, FOAMY, AND/OR MILKY - Continued**STEP****2. IS TRANSMISSION OIL CONTAMINATED WITH DIRT OR METAL PARTICLES?**

Visually check transmission fluid for dirt or metal particles (Volume 5, WP 0820).

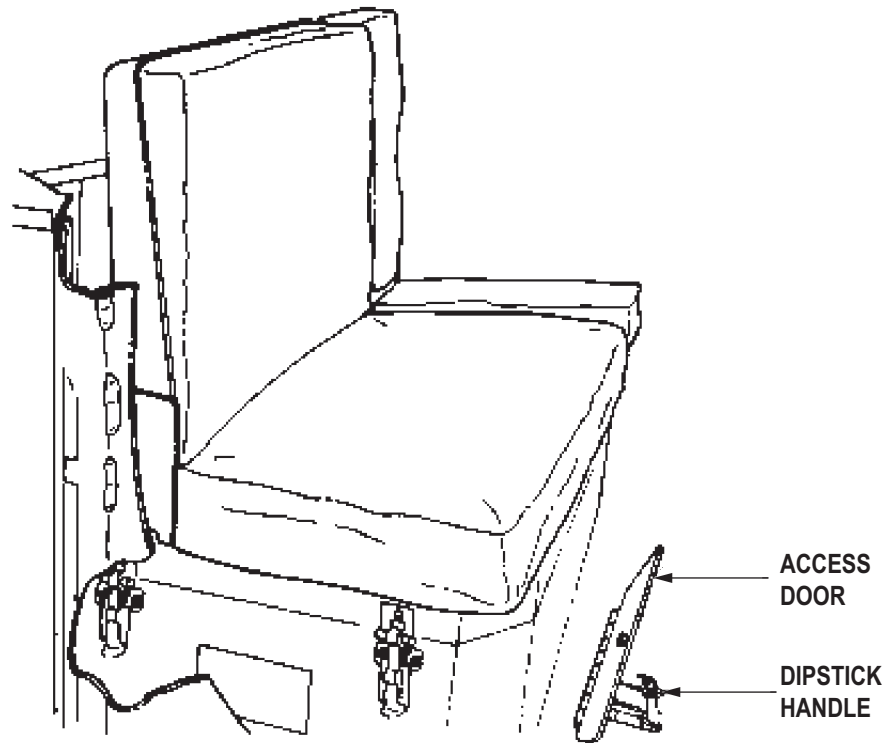

T1018DAA

Figure 2. Transmission Dipstick.

CONDITION/INDICATION

IS TRANSMISSION OIL CONTAMINATED WITH DIRT OR METAL PARTICLES?

DECISION

YES - Perform Dirt Or Metal Particles In Transmission Oil troubleshooting (WP 0037).
NO - Go to Step (3).

TRANSMISSION OIL DIRTY, FOAMY, AND/OR MILKY - Continued**STEP****3. IS TRANSMISSION OIL LEVEL CORRECT?****NOTE**

High or low oil levels may cause transmission oil to foam.
Visually check transmission fluid level (Volume 5, WP 0820).

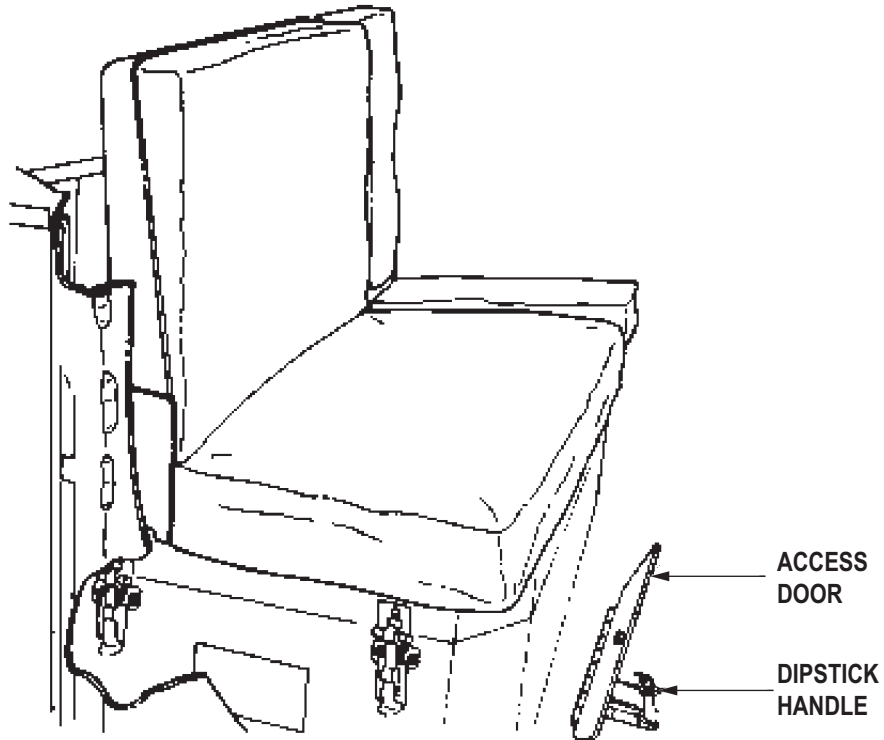

T1018DAA

Figure 3. Transmission Dipstick.

CONDITION/INDICATION

IS TRANSMISSION OIL LEVEL CORRECT?

DECISION

YES - Add or subtract fluid as necessary (Volume 3, WP 0362). Go to Step (5) to verify problem is solved.
NO - Go to Step (4).

TRANSMISSION OIL DIRTY, FOAMY, AND/OR MILKY - Continued**STEP****4. IS TRANSMISSION OIL CONTAMINATED WITH COOLANT?**

Visually check transmission if fluid is milky (Volume 5, WP 0820).

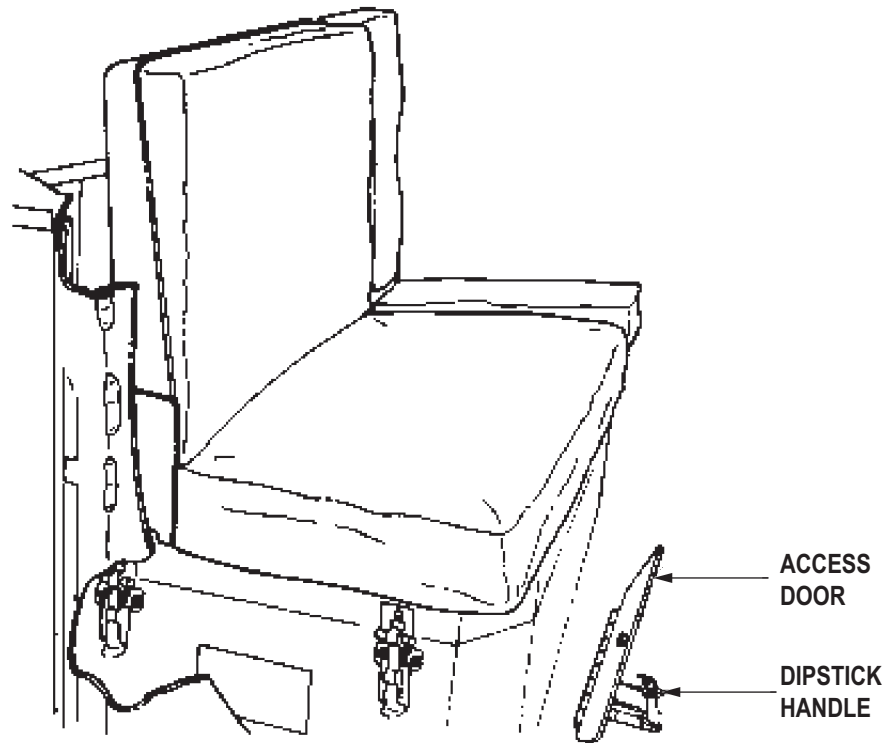

T1018DAA

Figure 4. Transmission Dipstick.

CONDITION/INDICATION

IS TRANSMISSION OIL CONTAMINATED WITH COOLANT?

DECISION

YES - Perform Loss Of Coolant troubleshooting (WP 0029).

NO - Go to Step (5) to verify problem is solved.

TRANSMISSION OIL DIRTY, FOAMY, AND/OR MILKY - Continued**STEP**

5. IS YOUR ORIGINAL PROBLEM STILL PRESENT?
 - a. Perform transmission oil service (Volume 3, WP 0362) if one has not been done.
 - b. Ensure vehicle is returned to normal operating condition.
 - c. Check to see if your original problem still exists.

CONDITION/INDICATION

IS YOUR ORIGINAL PROBLEM STILL PRESENT?

DECISION

YES - Notify supervisor.
NO - Problem fixed.

END OF WORK PACKAGE

**FIELD MAINTENANCE
HARD SHIFTING OF TRANSFER CASE**

INITIAL SETUP:**Tools and Special Tools**

Tool Kit, General Mechanic's: Automotive
(Volume 5, WP 0826, Table 1, Item 56)
Test Set, Electronic Systems
(Volume 5, WP 0826, Table 1, Item 51)

References (cont.)

Volume 2, WP 0307
Volume 3, WP 0352
Volume 3, WP 0396
Volume 5, WP 0820

Personnel Required

(2)

Equipment Condition

Vehicle parked and engine shut down.
(TM 9-2320-272-10)

References

Point to Point Schematics

TROUBLESHOOTING PROCEDURE**HARD SHIFTING OF TRANSFER CASE****NOTE**

Conduct these malfunction tests if transfer case is hard shifting or will not shift. This procedure will check transfer case for fluid level, transfer case shift linkage for damage or missing parts, proper lubrication, and defective linear valve transfer case shift lever switch and wiring.

HARD SHIFTING OF TRANSFER CASE - Continued**STEP**

1. IS TRANSFER CASE FLUID LEVEL CORRECT?
 - a. Visually inspect transfer case fluid level.



T0509DAA

Figure 1. Transfer Case.

- b. Access and remove transfer case fill plug.
- c. Check for fluid presence at fill plug opening.
- d. If fluid is not at fill plug opening, add fluid as necessary (Volume 5, WP 0820).
- e. Install fill plug.

CONDITION/INDICATION

IS TRANSFER CASE FLUID LEVEL CORRECT?

DECISION

- YES - Go to Step (2).
NO - Fluid added. Go to Step (7) to verify problem is solved.

HARD SHIFTING OF TRANSFER CASE - Continued**STEP**

2. IS TRANSFER CASE SHIFT LINKAGE IN GOOD OPERATING CONDITION?
 - a. Visually inspect transfer case shift linkage for broken, bent, or missing parts.

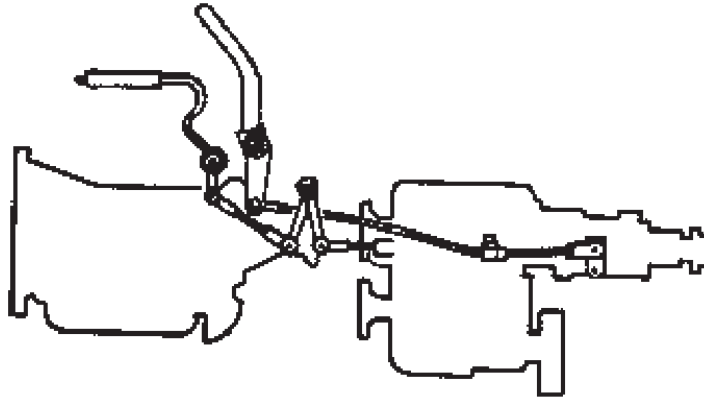

T0510DAA

Figure 2. Transfer Case Linkage.

- b. Inspect and lubricate linkage as necessary (Volume 5, WP 0820).

CONDITION/INDICATION

IS TRANSFER CASE SHIFT LINKAGE IN GOOD OPERATING CONDITION?

DECISION

YES - Go to Step (3).

NO - Replace any bent, broken, or missing parts (Volume 3, WP 0396). Go to Step (7) to verify problem is solved.

HARD SHIFTING OF TRANSFER CASE - Continued**STEP**

3. IS THERE BATTERY VOLTAGE AT CIRCUIT 586 WIRE?
 - a. Check for battery voltage at circuit 586 wire. Refer to point to point schematics.
 - b. Place battery to OFF position.
 - c. Disconnect circuit 586 wire from transfer case control switch.

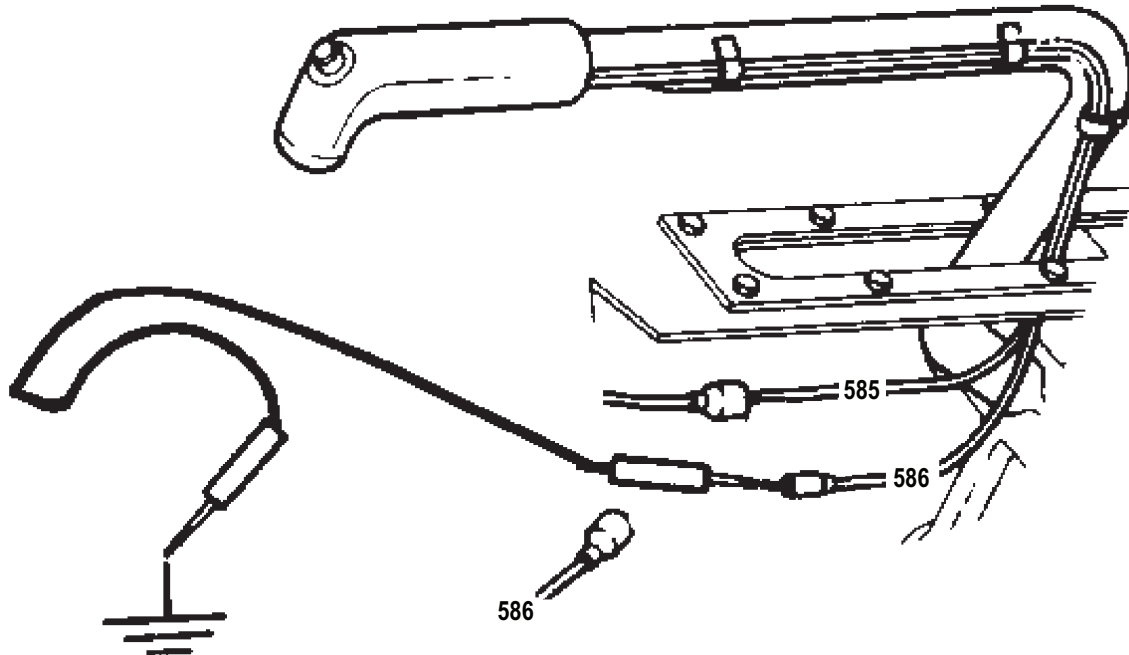

T0118DAA

Figure 3. Circuit 586 Wire.

- d. Place battery switch to ON position.
- e. Place transmission control lever to neutral.
- f. Set multimeter to VDC.
- g. Connect red multimeter lead to disconnected circuit 586 wire as shown.
- h. Connect black multimeter lead to vehicle chassis ground.
- i. Make sure transfer case control switch button is depressed.
- j. Meter reading should be greater than 18 VDC.

CONDITION/INDICATION

IS THERE BATTERY VOLTAGE AT CIRCUIT 586 WIRE?

DECISION

YES - Notify supervisor. It is possible that another troubleshooting work package applies.
 NO - Go to Step (4).

HARD SHIFTING OF TRANSFER CASE - Continued**STEP**

4. DOES CIRCUIT 585 WIRE SUPPLY CONTROL SWITCH WITH BATTERY VOLTAGE?
 - a. Check for battery voltage at circuit 585 wire. Refer to point to point schematics.
 - b. Place battery to OFF position.
 - c. Reconnect circuit 586 wire.
 - d. Disconnect circuit 585 wire from transfer case control switch.

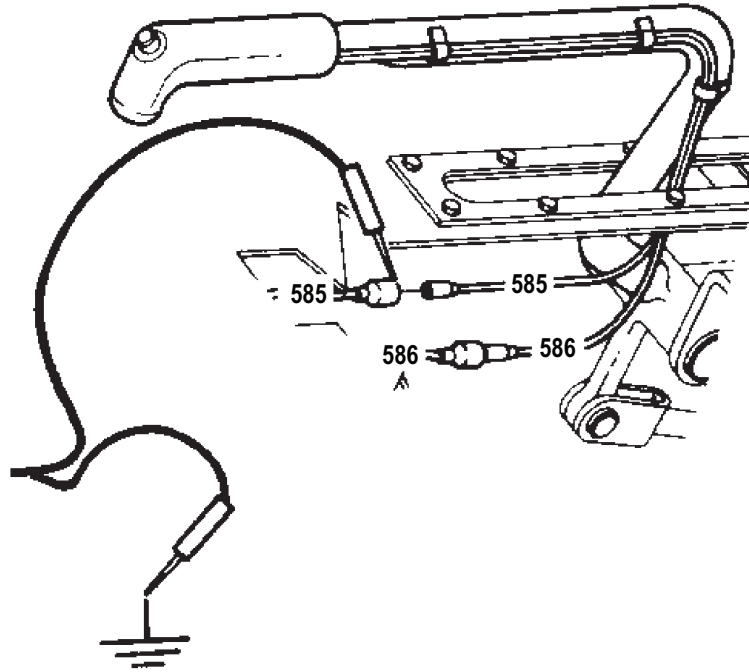

T0117DAA

Figure 4. Circuit 585 Wire.

- e. Place battery switch to ON position.
- f. Connect red multimeter lead to disconnected circuit 585 wire as shown.
- g. Connect black multimeter lead to vehicle chassis ground.
- h. Meter reading should be greater than 18 VDC.

CONDITION/INDICATION

DOES CIRCUIT 585 WIRE SUPPLY CONTROL SWITCH WITH BATTERY VOLTAGE?

DECISION

YES - Replace transfer case control switch (Volume 3, WP 0396). Go to Step (7) to verify problem is solved.
 NO - Go to Step (5).

HARD SHIFTING OF TRANSFER CASE - Continued**STEP**

5. IS THERE BATTERY VOLTAGE AT CIRCUIT 37 TERMINAL OF CIRCUIT BREAKER?
- Check for battery voltage at circuit breaker 37 terminal. Refer to point to point schematics.
 - Place battery to OFF position.
 - Reconnect circuit 585 wire.
 - Disconnect circuit 37 wire from circuit breaker.

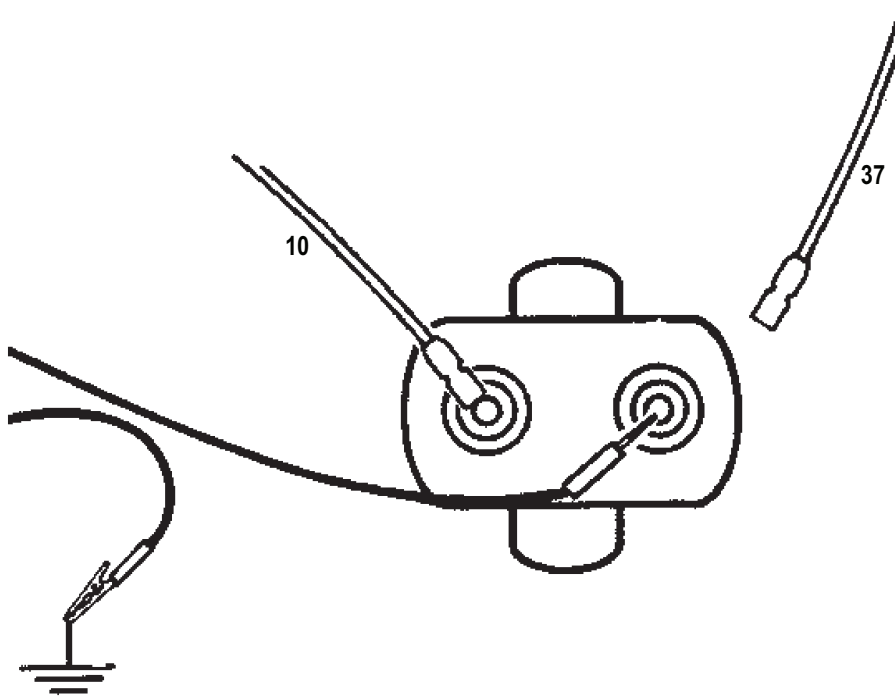

T0116DAA

Figure 5. Circuit 37 Breaker.

- Place battery switch to ON position.
- Connect red multimeter lead to circuit breaker 37 terminal.
- Connect black multimeter lead to vehicle chassis ground.

NOTE

If voltage is present, circuit wire 585 is faulty.

- Meter reading should be greater than 18 VDC.

CONDITION/INDICATION

IS THERE BATTERY VOLTAGE AT CIRCUIT 37 TERMINAL OF CIRCUIT BREAKER?

DECISION

YES - Repair circuit 585 wire (Volume 3, WP 0352). Go to Step (7) to verify problem is solved.
 NO - Go to Step (6).

HARD SHIFTING OF TRANSFER CASE - Continued**STEP**

6. IS THERE BATTERY VOLTAGE AT TRANSFER CASE CONTROL CIRCUIT BREAKER?
- Place battery to OFF position.
 - Reconnect circuit 37 wire.
 - Disconnect circuit 10 wire from circuit breaker. Refer to point to point schematics.

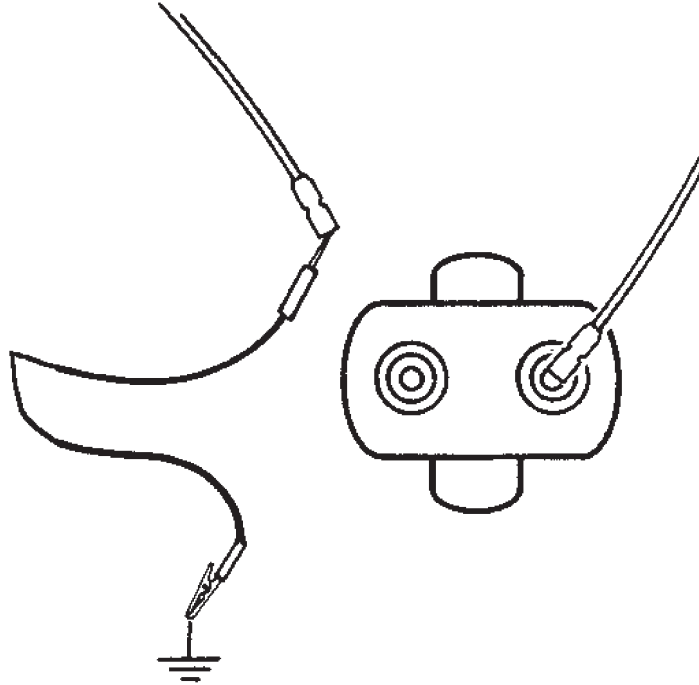

T0115DAA

Figure 6. Circuit 10 Breaker.

- Place battery switch to ON position.
- Connect red multimeter lead to circuit 10 wire as shown.
- Connect black multimeter lead to vehicle chassis ground.
- Meter reading should be greater than 18 VDC.

CONDITION/INDICATION

IS THERE BATTERY VOLTAGE AT TRANSFER CASE CONTROL CIRCUIT BREAKER?

DECISION

YES - Replace circuit breaker (Volume 2, WP 0307). Go to Step (7) to verify problem is solved.
 NO - Repair circuit 10 wire (Volume 3, WP 0352). Go to Step (7) to verify problem is solved.

HARD SHIFTING OF TRANSFER CASE - Continued**STEP**

7. IS YOUR ORIGINAL PROBLEM STILL PRESENT?
 - a. Ensure vehicle is returned to normal operating condition.
 - b. Check to see if your original problem still exists.

CONDITION/INDICATION

IS YOUR ORIGINAL PROBLEM STILL PRESENT?

DECISION

YES - Notify supervisor.
NO - Problem fixed.

END OF WORK PACKAGE

**FIELD MAINTENANCE
TRANSFER CASE LEAKING OIL**

INITIAL SETUP:**Tools and Special Tools**

Tool Kit, General Mechanic's: Automotive
(Volume 5, WP 0826, Table 1, Item 56)

References (cont.)

Volume 3, WP 0385
Volume 3, WP 0386

Personnel Required

(2)

Equipment Condition

Vehicle parked and engine shut down.
(TM 9-2320-272-10)

References

Point to Point Schematics

TROUBLESHOOTING PROCEDURE**TRANSFER CASE LEAKING OIL****NOTE**

Conduct these malfunction tests if transfer case oil leaks are detected. This procedure will check for leaks or looseness from drain plugs and leaks from transfer case housing.

TRANSFER CASE LEAKING OIL - Continued**STEP**

1. ARE FILL AND DRAIN PLUGS OR TRANSFER CASE HOUSING LEAKING OIL?
 - a. Visually check transfer case fill and drain plugs for leaks and looseness.

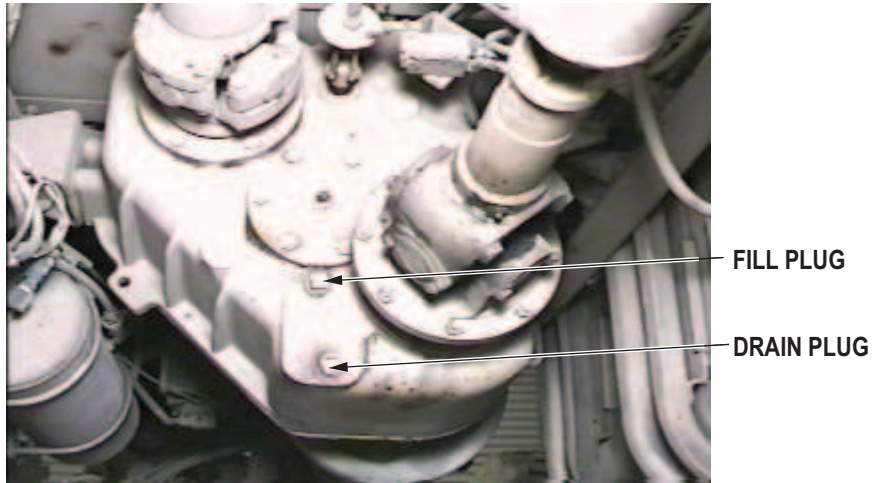

T0869DAA

Figure 1. Transfer Case.

- b. Visually inspect transfer case housing for leaks.

CONDITION/INDICATION

ARE FILL AND DRAIN PLUGS OR TRANSFER CASE HOUSING LEAKING OIL?

DECISION

- YES - Fill and drain plugs leak or are loose. Tighten loose fill and drain plugs. Go to Step (2) to verify problem is solved.
- YES - Transfer case housing leaks. Replace transfer case (Volume 3, WP 0385), M936 (Volume 3, WP 0386). Go to Step (2) to verify problem is solved.
- NO - Go to Step (2) to verify problem is solved.

TRANSFER CASE LEAKING OIL - Continued**STEP**

2. IS YOUR ORIGINAL PROBLEM STILL PRESENT?
 - a. Ensure vehicle is returned to normal operating condition.
 - b. Check to see if your original problem still exists.

CONDITION/INDICATION

IS YOUR ORIGINAL PROBLEM STILL PRESENT?

DECISION

YES - Notify supervisor.
NO - Problem fixed.

END OF WORK PACKAGE

**FIELD MAINTENANCE
EXCESSIVE NOISE**

INITIAL SETUP:**Tools and Special Tools**

Tool Kit, General Mechanic's: Automotive
(Volume 5, WP 0826, Table 1, Item 56)

Equipment Condition

Vehicle parked and engine shut down.
(TM 9-2320-272-10)

Personnel Required

(2)

References

Point to Point Schematics
Volume 5, WP 0820

TROUBLESHOOTING PROCEDURE**EXCESSIVE NOISE****NOTE**

Conduct these malfunction test if excessive transfer case noise is detected. This procedure will check transfer case fluid level.

EXCESSIVE NOISE - Continued**STEP**

1. IS TRANSFER CASE FLUID LEVEL CORRECT?
 - a. Visually inspect transfer case fluid level.



T1105DAA

Figure 1. Transfer Case.

- b. Access and remove transfer case fill plug.
- c. Check for fluid presence at fill plug opening.
- d. If fluid is not at fill plug opening, add fluid as necessary (Volume 5, WP 0820).
- e. Install fill plug.

CONDITION/INDICATION

IS TRANSFER CASE FLUID LEVEL CORRECT?

DECISION

YES - Notify supervisor. It is possible that another troubleshooting work package applies.
NO - Fluid added. Go to Step (2) to verify problem is solved.

EXCESSIVE NOISE - Continued**STEP**

2. IS YOUR ORIGINAL PROBLEM STILL PRESENT?
 - a. Ensure vehicle is returned to normal operating condition.
 - b. Check to see if your original problem still exists.

CONDITION/INDICATION

IS YOUR ORIGINAL PROBLEM STILL PRESENT?

DECISION

YES - Notify supervisor.
NO - Problem fixed.

END OF WORK PACKAGE

**FIELD MAINTENANCE
EXCESSIVE VIBRATION**

INITIAL SETUP:**Tools and Special Tools**

Tool Kit, General Mechanic's: Automotive
(Volume 5, WP 0826, Table 1, Item 56)
Wrench, Torque, Click, Ratcheting, 3/8" Drive,
75 Ft-Lb
(Volume 5, WP 0826, Table 1, Item 62)

Personnel Required

(2)

References

Point to Point Schematics

References (cont.)

Volume 3, WP 0401
Volume 3, WP 0402
Volume 5, WP 0820

Equipment Condition

Vehicle parked and engine shut down.
(TM 9-2320-272-10)

TROUBLESHOOTING PROCEDURE**EXCESSIVE VIBRATION****NOTE**

Conduct these malfunction tests if there is excessive vibration from transfer case. This procedure will check for proper transfer case fluid level and proper torque of yoke and companion flange screws.

EXCESSIVE VIBRATION - Continued**STEP**

1. IS TRANSFER CASE FLUID LEVEL CORRECT?
 - a. Visually inspect transfer case fluid level.

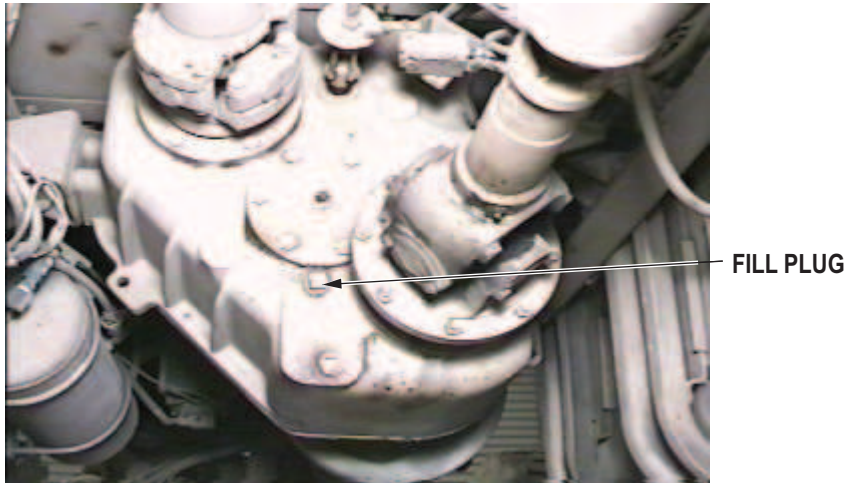

T0509DAA

Figure 1. Transfer Case.

EXCESSIVE VIBRATION - Continued

- b. Access and remove transfer case fill plug.
- c. Check for fluid presence at fill plug opening.
- d. If fluid is not at fill plug opening, add fluid as necessary (Volume 5, WP 0820).
- e. Install fill plug.

CONDITION/INDICATION

IS TRANSFER CASE FLUID LEVEL CORRECT?

DECISION

YES - Go to Step (2).

NO - Fluid added. Go to Step (3) to verify problem is solved.

EXCESSIVE VIBRATION - Continued**STEP**

2. DO YOKE AND COMPANION FLANGE SCREWS HAVE PROPER TORQUE?
 - a. Check all yoke and companion flange screws for looseness.

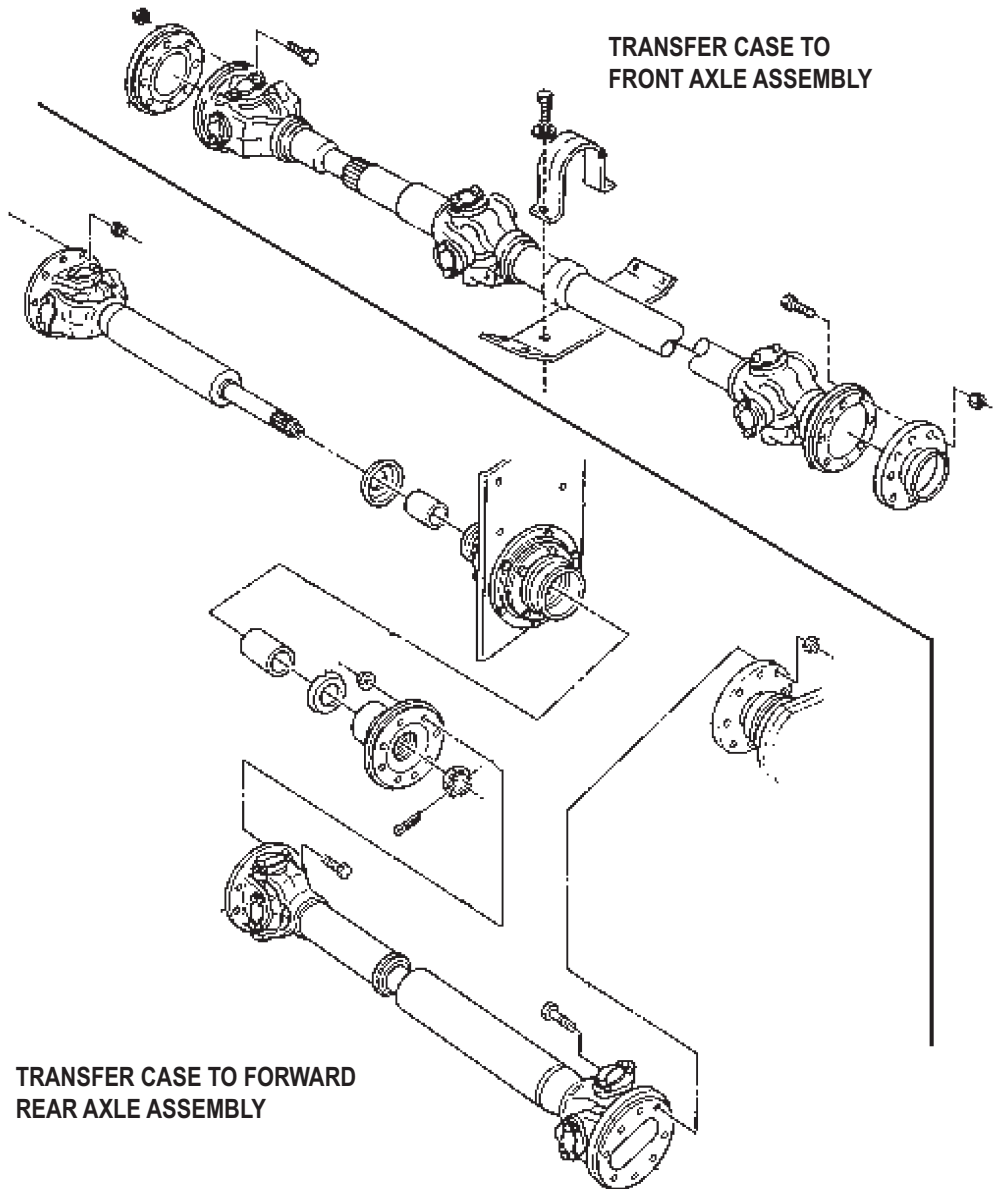

T0518DAA

Figure 2. Propeller Shafts.

- b. Flange lock nuts should be tightened to 30 to 40 ft-lb (43 to 54 N-m).

EXCESSIVE VIBRATION - Continued**CONDITION/INDICATION**

DO YOKE AND COMPANION FLANGE SCREWS HAVE PROPER TORQUE?

DECISION

YES - Go to Step (3) to verify problem is solved.

NO - Transfer to front axle flange screws loose. Tighten any loose screws (Volume 3, WP 0402). Go to Step (3) to verify problem is solved.

NO - Transfer to forward rear axle flange screws loose. Tighten any loose screws (Volume 3, WP 0401). Go to Step (3) to verify problem is solved.

STEP

3. IS YOUR ORIGINAL TRANSFER CASE VIBRATION PROBLEM STILL PRESENT?

- a. Ensure vehicle is returned to normal operating condition.
- b. Check to see if your original transfer case vibration problem still exists.

CONDITION/INDICATION

IS YOUR ORIGINAL TRANSFER CASE VIBRATION PROBLEM STILL PRESENT?

DECISION

YES - Notify supervisor.

NO - Problem fixed.

END OF WORK PACKAGE

FIELD MAINTENANCE
EXCESSIVE PROPELLER AND DRIVE SHAFTS NOISE OR VIBRATION

INITIAL SETUP:**Tools and Special Tools**

Tool Kit, General Mechanic's: Automotive
(Volume 5, WP 0826, Table 1, Item 56)
Wrench, Torque, Click, Ratcheting, 3/8" Drive,
75 Ft-Lb
(Volume 5, WP 0826, Table 1, Item 62)

References (cont.)

Volume 3, WP 0401
Volume 3, WP 0402
Volume 3, WP 0403
Volume 5, WP 0820

Personnel Required

(2)

Equipment Condition

Vehicle parked and engine shut down.
(TM 9-2320-272-10)

References

Point to Point Schematics

TROUBLESHOOTING PROCEDURE**EXCESSIVE PROPELLER AND DRIVE SHAFTS NOISE OR VIBRATION****NOTE**

Conduct these malfunction tests if excessive noise or vibration from propeller and drive shafts is detected. This procedure will check universal joint lubrication, torque of all propeller shaft yoke screws, propeller shaft for wear and damage and center bearing for looseness and damage.

EXCESSIVE PROPELLER AND DRIVE SHAFTS NOISE OR VIBRATION - Continued**STEP****1. ARE UNIVERSAL JOINTS PROPERLY LUBRICATED?**

Visually check universal joints for proper lubrication.

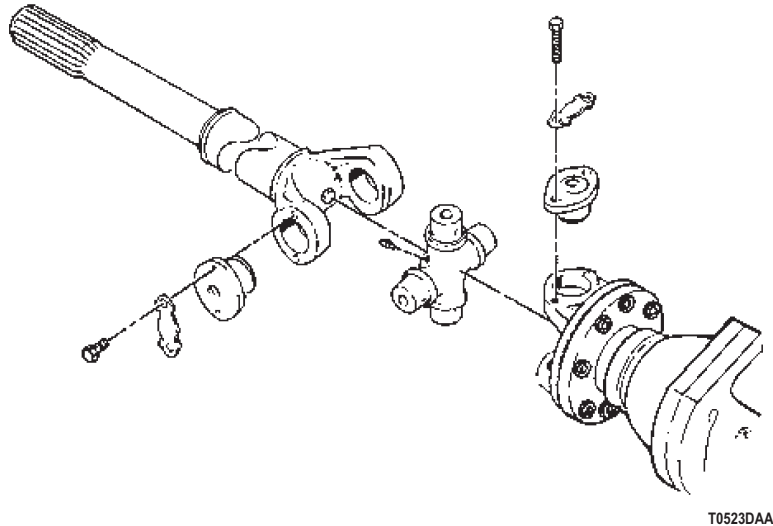

Figure 1. Universal Joints.

CONDITION/INDICATION

ARE UNIVERSAL JOINTS PROPERLY LUBRICATED?

DECISION

YES - Go to Step (2).

NO - Lubricate universal joints (Volume 5, WP 0820). Go to Step (4) to verify problem is solved.

STEP**2. ARE ALL PROPELLER SHAFT COMPONENTS IN GOOD OPERATING CONDITION?**

- a. Check torque of all propeller shaft flange yoke screws.
- b. Tighten any loose propeller shaft flange yoke screws to 32-40 ft-lb (43-54 N·m).

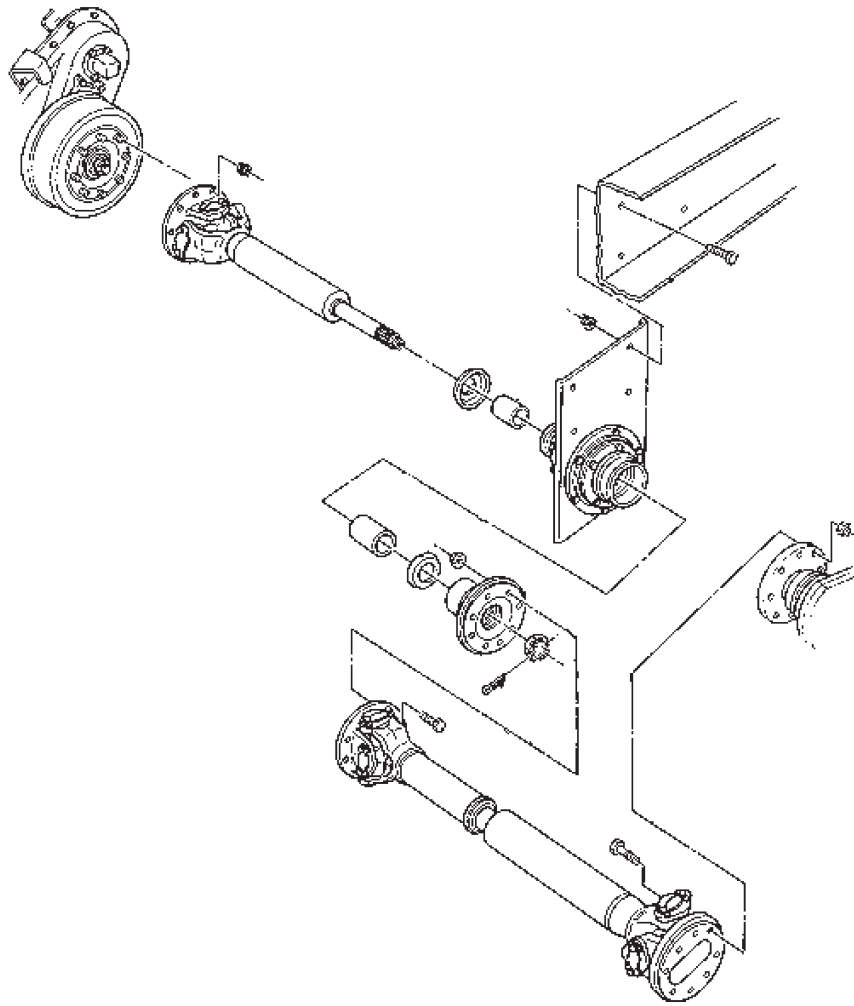
EXCESSIVE PROPELLER AND DRIVE SHAFTS NOISE OR VIBRATION - Continued

T0524DAA

Figure 2. Propeller Shaft.

- c. Visually check all propeller shafts for wear and damage.

CONDITION/INDICATION

ARE ALL PROPELLER SHAFT COMPONENTS IN GOOD OPERATING CONDITION?

DECISION

YES - Go to Step (3).

NO - Transmission to transfer damaged. Replace damaged propeller shaft (Volume 3, WP 0403). Go to Step (4) to verify problem is solved.

NO - Transfer to forward rear axle propeller shaft damaged. Replace damaged propeller shaft (Volume 3, WP 0401). Go to Step (4) to verify problem is solved.

NO - Transfer to front axle propeller shaft damaged. Replace damaged propeller shaft (Volume 3, WP 0402). Go to Step (4) to verify problem is solved.

EXCESSIVE PROPELLER AND DRIVE SHAFTS NOISE OR VIBRATION - Continued**STEP**

3. IS CENTER BEARING ASSEMBLY IN GOOD OPERATING CONDITION?
 - a. Visually inspect center bearing assembly for looseness and damage.

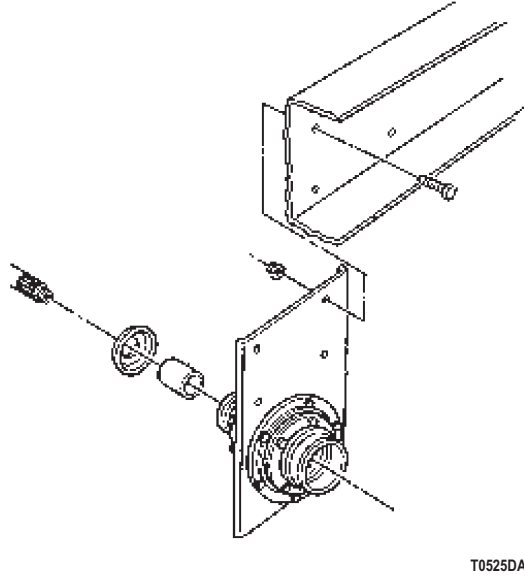

Figure 3. Center Bearing.

- b. Tighten center bearing to forward rear axle propeller shaft yoke to transfer to center bearing rear flange screws to 32-40 ft-lb (43-54 N·m).

CONDITION/INDICATION

IS CENTER BEARING ASSEMBLY IN GOOD OPERATING CONDITION?

DECISION

YES - Go to Step (4) to verify problem is solved.

NO - Replace damaged center bearing assembly (Volume 3, WP 0401). Go to Step (4) to verify problem is solved.

EXCESSIVE PROPELLER AND DRIVE SHAFTS NOISE OR VIBRATION - Continued

STEP

4. IS YOUR ORIGINAL PROBLEM STILL PRESENT?
 - a. Ensure vehicle is returned to normal operating condition.
 - b. Check to see if your propeller and drive shafts noise or vibration problem still exists.

CONDITION/INDICATION

IS YOUR ORIGINAL PROBLEM STILL PRESENT?

DECISION

YES - Notify supervisor.
NO - Problem fixed.

END OF WORK PACKAGE

**FIELD MAINTENANCE
CONTINUOUS AXLE OR WHEEL NOISE**

INITIAL SETUP:**Tools and Special Tools**

Tool Kit, General Mechanic's: Automotive
(Volume 5, WP 0826, Table 1, Item 56)
High Boy Jack Stands
(Volume 5, WP 0826, Table 1, Item 24)

References (cont.)

Volume 3, WP 0404
Volume 3, WP 0411
Volume 3, WP 0484
Volume 3, WP 0485
Volume 5, WP 0820

Personnel Required

(2)

Equipment Condition

Vehicle parked and engine shut down.
(TM 9-2320-272-10)

References

Point to Point Schematics

TROUBLESHOOTING PROCEDURE**CONTINUOUS AXLE OR WHEEL NOISE****NOTE**

Conduct these malfunction tests if there is continuous axle or wheel noise. This procedure will check if the front wheel drive is engaged when traveling on hard surfaces, for missing wheel lug nuts, axle and differential lubrication and loose or damaged wheel bearings.

CONTINUOUS AXLE OR WHEEL NOISE - Continued**STEP**

1. WAS FRONT WHEEL DRIVE ENGAGED WHILE TRAVELING ON HARD FLAT SURFACE?
 - a. Visually inspect if front wheel drive is engaged.

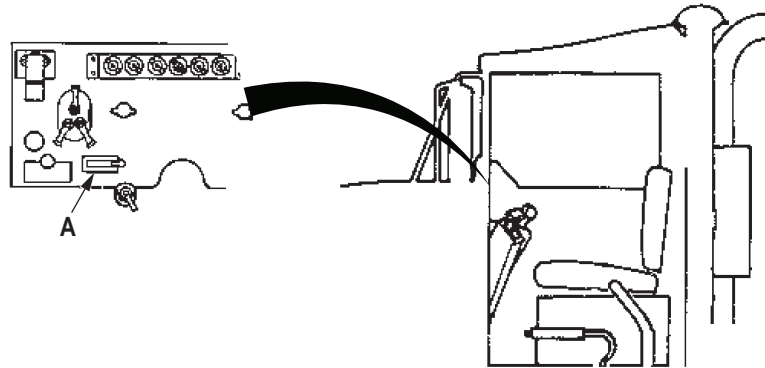

A FRONT WHEEL DRIVE LOCK - IN SWITCH

T0528DAA

Figure 1. Front Wheel Drive Lock-In Switch.

- b. Locate front wheel drive lock-in switch and check for engaged position.
 - c. Disengaged front wheel drive when traveling on hard flat surfaces.

CONDITION/INDICATION

WAS FRONT WHEEL DRIVE ENGAGED WHILE TRAVELING ON HARD FLAT SURFACE?

DECISION

- YES - Go to Step (6) to verify problem is solved.
NO - Go to Step (2).

CONTINUOUS AXLE OR WHEEL NOISE - Continued**STEP****2. ARE THERE ANY LOOSE OR MISSING WHEEL LUG NUTS?**

Visually check for loose or missing wheel lug nuts.

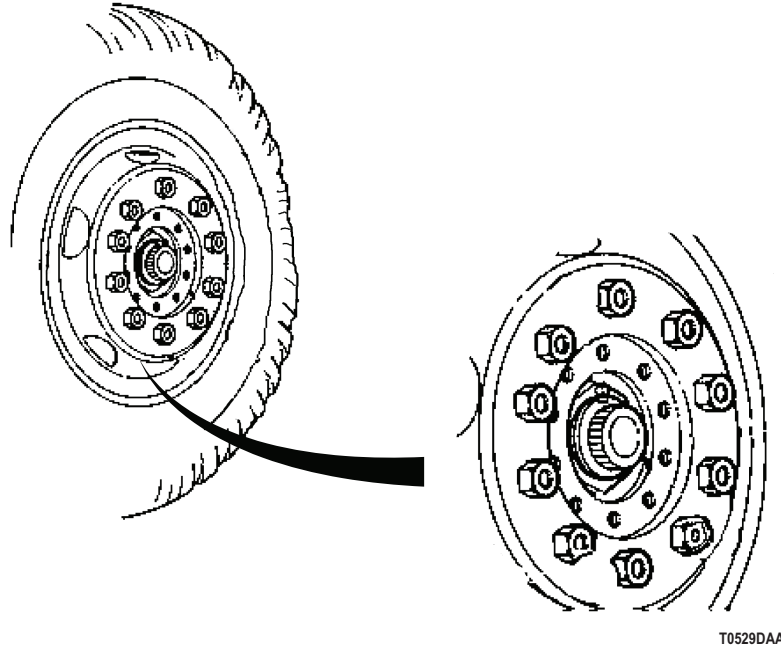

Figure 2. Wheel Lug Nuts.

CONDITION/INDICATION

ARE THERE ANY LOOSE OR MISSING WHEEL LUG NUTS?

DECISION

YES - Tighten or replace wheel lug nuts M939 (Volume 3, WP 0484), M939A1/A2 (Volume 3, WP 0485). Go to Step (6) to verify problem is solved.

NO - Go to Step (3).

CONTINUOUS AXLE OR WHEEL NOISE - Continued**STEP****3. IS AXLE HOUSING AND DIFFERENTIAL PROPERLY LUBRICATED?**

- a. Visually check front and rear axle housing and differential lubrication level.

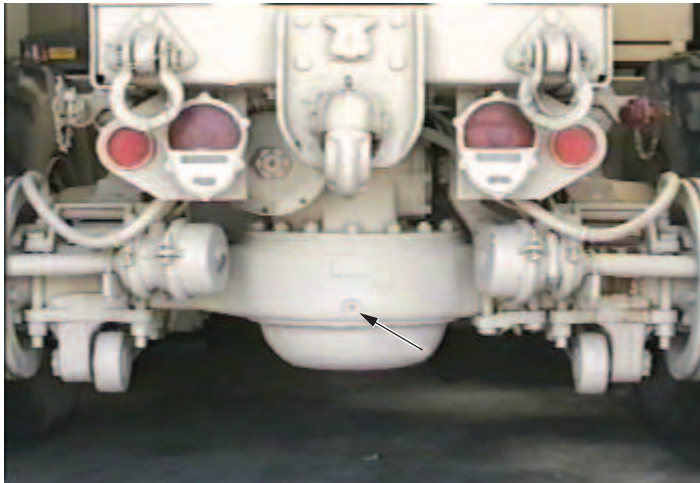

T0526DAA

Figure 3. Differential Lubrication Level.

- b. Remove axle housing drain plug and check for fluid level at drain plug opening.

CONDITION/INDICATION

IS AXLE HOUSING AND DIFFERENTIAL PROPERLY LUBRICATED?

DECISION

YES - Go to Step (4).

NO - Fill axle housing to proper level (Volume 5, WP 0820). Go to Step (6) to verify problem is solved.

CONTINUOUS AXLE OR WHEEL NOISE - Continued**STEP**

4. ARE WHEEL BEARINGS IN GOOD OPERATING CONDITION?
 - a. Visually check wheel bearing for adjustment and damage.

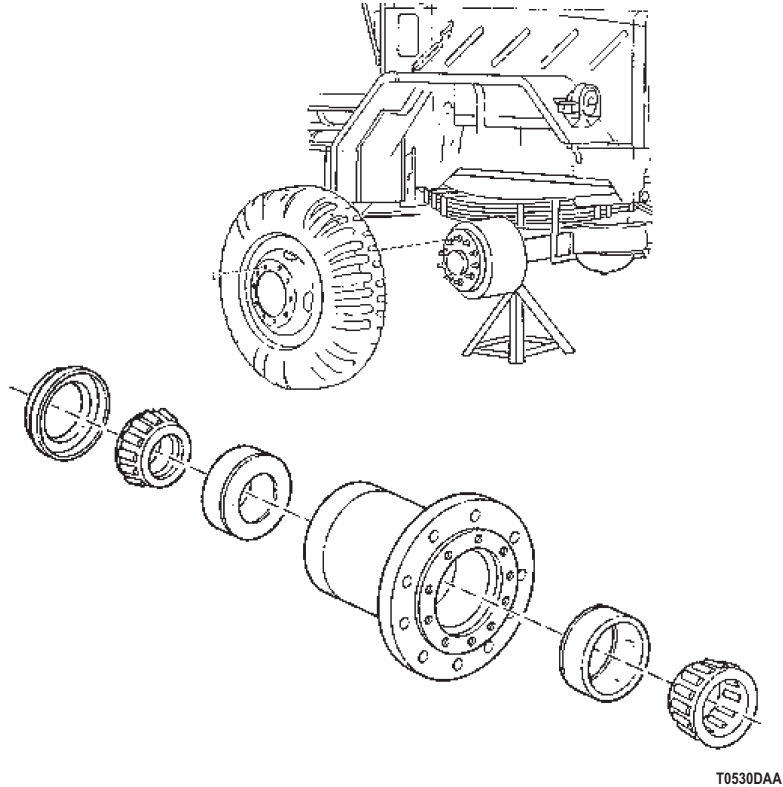

Figure 4. Wheel Bearings.

- b. Raise vehicle wheels until they are off the ground M939 (Volume 3, WP 0484), M939A1/A2 (Volume 3, WP 0485).

NOTE

Excessive play indicates improperly adjusted or damaged bearings.

- c. Lift up on bottom of tire using prybar to determine bearing play.

CONDITION/INDICATION

ARE WHEEL BEARINGS IN GOOD OPERATING CONDITION?

DECISION

YES - Go to Step (5).

NO - Moderate play. Adjust wheel bearing(s) (Volume 3, WP 0483). Go to Step (6) to verify problem is solved.

NO - Excessive play front wheel bearing damaged. Replace damaged front wheel bearings M939/A1 (Volume 3, WP 0479), M939A2 (Volume 3, WP 0481). Go to Step (6) to verify problem is solved.

NO - Excessive play rear wheel bearing damaged. Replace damaged rear wheel bearings M939/A1 (Volume 3, WP 0480), M939A2 (Volume 3, WP 0482). Go to Step (6) to verify problem is solved.

CONTINUOUS AXLE OR WHEEL NOISE - Continued**STEP**

5. ARE FRONT AXLE SHAFTS AND UNIVERSAL JOINTS IN GOOD OPERATING CONDITION?

Check front axle shafts and universal joints for defects (Volume 3, WP 0411).

CONDITION/INDICATION

ARE FRONT AXLE SHAFTS AND UNIVERSAL JOINTS IN GOOD OPERATING CONDITION?

DECISION

YES - Replace faulty axle (Volume 3, WP 0404). Go to Step (6) to verify problem is solved.

NO - Repair or replace defective components (Volume 3, WP 0411). Go to Step (6) to verify problem is solved.

STEP

6. IS YOUR ORIGINAL AXLE OR WHEEL NOISE PROBLEM STILL PRESENT?

- a. Ensure vehicle is returned to normal operating condition.
- b. Check to see if your axle or wheel noise problem still exists.

CONDITION/INDICATION

IS YOUR ORIGINAL AXLE OR WHEEL NOISE PROBLEM STILL PRESENT?

DECISION

YES - Notify supervisor.

NO - Problem fixed.

END OF WORK PACKAGE

**FIELD MAINTENANCE
TOWING PINTLE DOES NOT LATCH OR LOCK**

INITIAL SETUP:**Tools and Special Tools**

Tool Kit, General Mechanic's: Automotive
(Volume 5, WP 0826, Table 1, Item 56)

Equipment Condition

Vehicle parked and engine shut down.
(TM 9-2320-272-10)

Personnel Required

(2)

References

Volume 3, WP 0518
Volume 5, WP 0820

TROUBLESHOOTING PROCEDURE**TOWING PINTLE DOES NOT LATCH OR LOCK****NOTE**

Conduct these malfunction tests if the towing pintle does not latch or lock. This procedure will check the pintle hook for lubrication, damaged parts, and proper operation.

TOWING PINTLE DOES NOT LATCH OR LOCK - Continued**STEP****1. IS PINTLE HOOK PROPERLY LUBRICATED?**

Visually check pintle hook for proper lubrication.

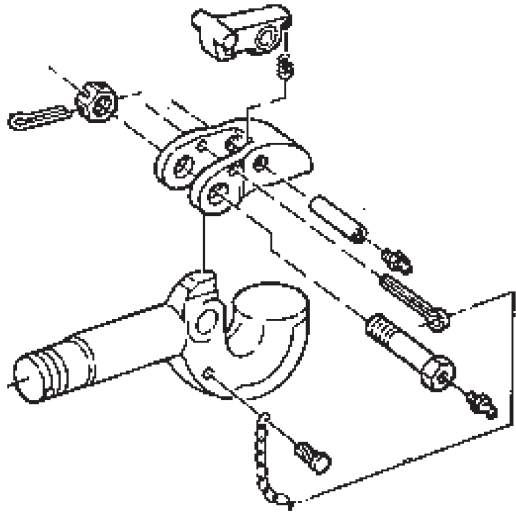

T0987DAA

Figure 1. Pintle Hook Assembly.

CONDITION/INDICATION

IS PINTLE HOOK PROPERLY LUBRICATED?

DECISION

YES - Go to Step (2).

NO - Lubricate pintle (Volume 5, WP 0820). Go to Step (3) to verify problem is solved.

TOWING PINTLE DOES NOT LATCH OR LOCK - Continued**STEP****2. IS PINTLE HOOK LOCK IN GOOD OPERATING CONDITION?**

Visually check pintle hook lock for bends, cracks, breaks and proper operation (Volume 3, WP 0518).

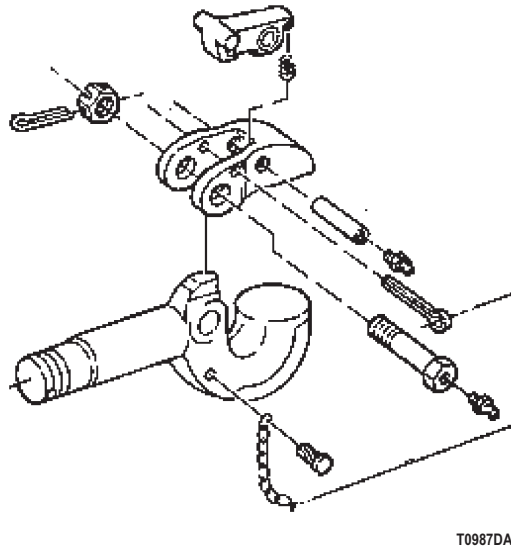

Figure 2. Pintle Hook Assembly.

CONDITION/INDICATION

IS PINTLE HOOK LOCK IN GOOD OPERATING CONDITION?

DECISION

YES - Go to Step (3) to verify problem is solved.

NO - Replace defective pintle hook lock (Volume 3, WP 0518). Go to Step (3) to verify problem is solved.

TOWING PINTLE DOES NOT LATCH OR LOCK - Continued**STEP**

3. IS YOUR ORIGINAL TOWING PINTLE PROBLEM STILL PRESENT?
 - a. Ensure vehicle is returned to normal operating condition.
 - b. Check to see if your original towing pintle problem still exists.

CONDITION/INDICATION

IS YOUR ORIGINAL TOWING PINTLE PROBLEM STILL PRESENT?

DECISION

YES - Notify supervisor.
NO - Problem fixed.

END OF WORK PACKAGE

**FIELD MAINTENANCE
PINTLE HOOK DOES NOT TURN**

INITIAL SETUP:**Tools and Special Tools**

Tool Kit, General Mechanic's: Automotive
(Volume 5, WP 0826, Table 1, Item 56)

Equipment Condition

Vehicle parked and engine shut down.
(TM 9-2320-272-10)

Personnel Required

(2)

References

Volume 3, WP 0518
Volume 5, WP 0820

TROUBLESHOOTING PROCEDURE**PINTLE HOOK DOES NOT TURN****NOTE**

Conduct these malfunction tests if the pintle hook does not turn. This procedure will check the pintle hook for lubrication, proper adjustment, and a bent shaft.

PINTLE HOOK DOES NOT TURN - Continued**STEP****1. IS PINTLE HOOK PROPERLY LUBRICATED?**

Visually check pintle hook for proper lubrication.

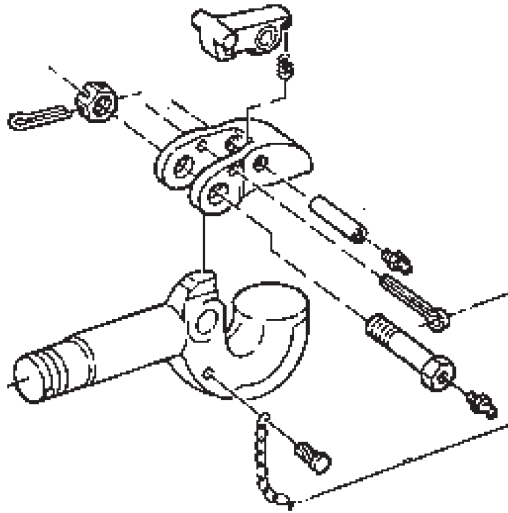

T0566DAA

Figure 1. Pintle Hook Assembly.

CONDITION/INDICATION

IS PINTLE HOOK PROPERLY LUBRICATED?

DECISION

YES - Go to Step (2).

NO - Lubricate pintle (Volume 5, WP 0820). Go to Step (4) to verify problem is solved.

PINTLE HOOK DOES NOT TURN - Continued**STEP**

2. IS THERE PROPER CLEARANCE BETWEEN THRUST WASHER AND MOUNTING BRACKET HOUSING?
 - a. Check clearance between thrust washer and mounting bracket housing using feeler gage.
 - b. Check that clearance is the same all around and within .010 in +/- .007 in. (.25 mm +/- .18 mm).

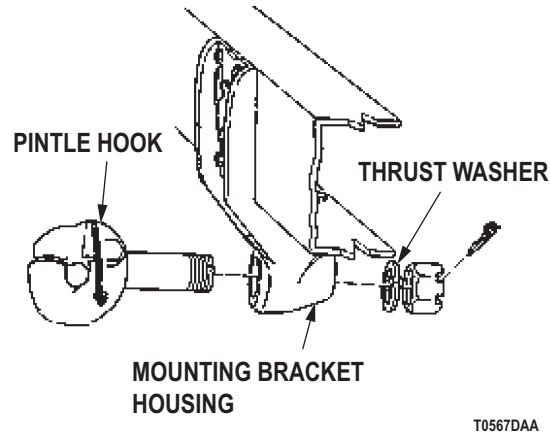

Figure 2. Pintle Hook Mounting Housing Bracket.

CONDITION/INDICATION

IS THERE PROPER CLEARANCE BETWEEN THRUST WASHER AND MOUNTING BRACKET HOUSING?

DECISION

YES - Go to Step (3).

NO - Adjust to proper clearance (Volume 3, WP 0518). Go to Step (4) to verify problem is solved.

PINTLE HOOK DOES NOT TURN - Continued**STEP****3. IS PINTLE HOOK SHAFT BENT?**

Visually check pintle hook shaft for bends.

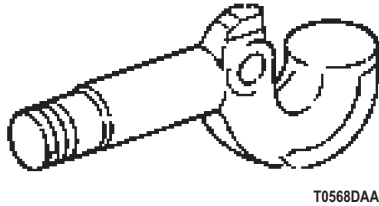

Figure 3. Pintle Hook Shaft.

CONDITION/INDICATION

IS PINTLE HOOK SHAFT BENT?

DECISION

YES - Replace bent pintle hook shaft (Volume 3, WP 0518). Go to Step (4) to verify problem is solved.

NO - Go to Step (4) to verify problem is solved.

STEP**4. IS YOUR ORIGINAL PINTLE HOOK PROBLEM STILL PRESENT?**

- a. Ensure vehicle is returned to normal operating condition.
- b. Check to see if your original pintle hook problem still exists.

CONDITION/INDICATION

IS YOUR ORIGINAL PINTLE HOOK PROBLEM STILL PRESENT?

DECISION

YES - Notify supervisor.

NO - Problem fixed.

END OF WORK PACKAGE

**FIELD MAINTENANCE
EXCESSIVELY LOOSE LIFTING SHACKLE**

INITIAL SETUP:**Tools and Special Tools**

Tool Kit, General Mechanic's: Automotive
(Volume 5, WP 0826, Table 1, Item 56)

References

Volume 3, WP 0512

Personnel Required

(2)

Equipment Condition

Vehicle parked and engine shut down.
(TM 9-2320-272-10)

TROUBLESHOOTING PROCEDURE**EXCESSIVELY LOOSE LIFTING SHACKLE****NOTE**

Conduct these malfunction tests if the lifting shackle is excessively loose. This procedure will check the shackle and shackle pin for wear and damage and the shackle mounting bracket for defective attaching hardware.

EXCESSIVELY LOOSE LIFTING SHACKLE - Continued**STEP****1. IS SHACKLE PIN IN GOOD OPERATING CONDITION?**

Visually check shackle pin for wear and bends.

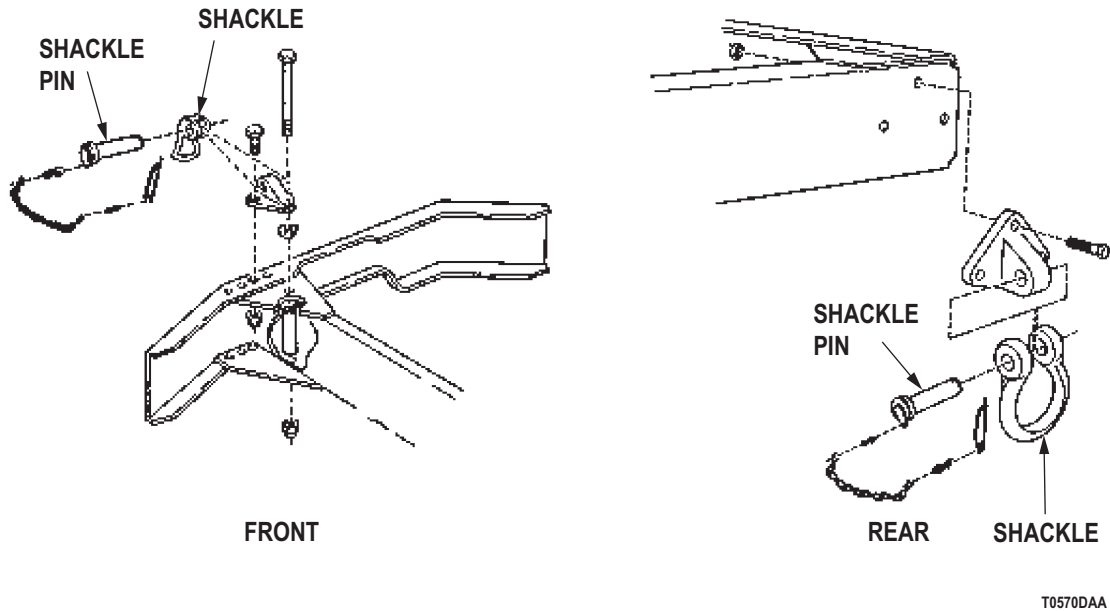

Figure 1. Front and Rear Shackle Pin Assembly.

CONDITION/INDICATION

IS SHACKLE PIN IN GOOD OPERATING CONDITION?

DECISION

YES - Go to Step (2).

NO - Replace worn or bent shackle pin (Volume 3, WP 0512). Go to Step (5) to verify problem is solved.

EXCESSIVELY LOOSE LIFTING SHACKLE - Continued**STEP****2. IS SHACKLE PIN THE CORRECT SIZE?**

Visually inspect shackle pin for correct size.

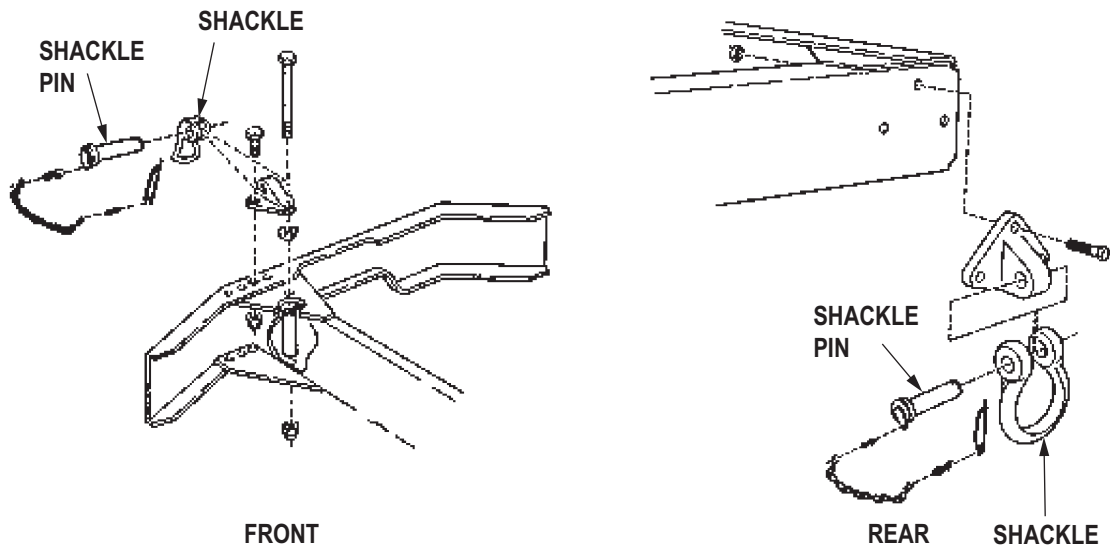

T0570DAA

Figure 2. Front and Rear Shackle Pin Assembly.

CONDITION/INDICATION

IS SHACKLE PIN THE CORRECT SIZE?

DECISION

YES - Go to Step (3).

NO - Replace shackle pin (Volume 3, WP 0512). Go to Step (5) to verify problem is solved.

EXCESSIVELY LOOSE LIFTING SHACKLE - Continued**STEP****3. IS SHACKLE IN GOOD OPERATING CONDITION?**

Visually inspect shackle for wear and bends.

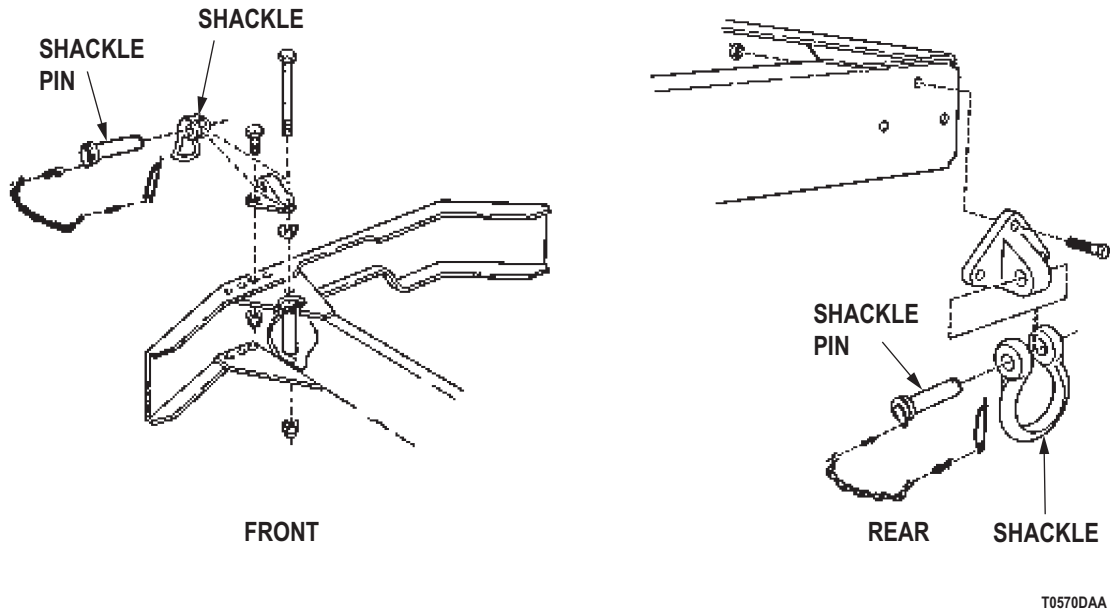

Figure 3. Front and Rear Shackle Pin Assembly.

CONDITION/INDICATION

IS SHACKLE IN GOOD OPERATING CONDITION?

DECISION

YES - Go to Step (4).

NO - Replace bent or worn shackle (Volume 3, WP 0512). Go to Step (5) to verify problem is solved.

EXCESSIVELY LOOSE LIFTING SHACKLE - Continued**STEP**

4. IS SHACKLE MOUNTING BRACKET ATTACHING HARDWARE LOOSE, DAMAGED, OR MISSING?

Visually inspect shackle mounting bracket for loose, damaged, or missing hardware.

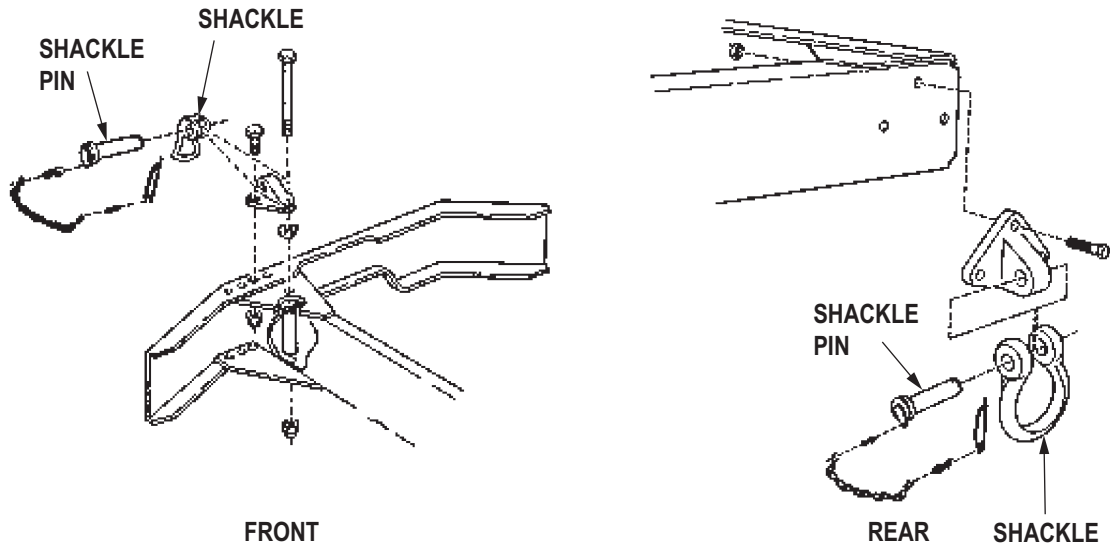

T0570DAA

Figure 4. Front and Rear Shackle Pin Assembly.

CONDITION/INDICATION

IS SHACKLE MOUNTING BRACKET ATTACHING HARDWARE LOOSE, DAMAGED, OR MISSING?

DECISION

YES - Replace defective mounting bracket hardware (Volume 3, WP 0512). Go to Step (5) to verify problem is solved.

NO - Go to Step (5) to verify problem is solved.

EXCESSIVELY LOOSE LIFTING SHACKLE - Continued**STEP**

5. IS YOUR ORIGINAL LOOSE LIFTING SHACKLE PROBLEM STILL PRESENT?
 - a. Ensure vehicle is returned to normal operating condition.
 - b. Check to see if your original loose lifting shackle problem still exists.

CONDITION/INDICATION

IS YOUR ORIGINAL LOOSE LIFTING SHACKLE PROBLEM STILL PRESENT?

DECISION

YES - Notify supervisor.
NO - Problem fixed.

END OF WORK PACKAGE

**FIELD MAINTENANCE
LOOSE SPARE TIRE CARRIER**

INITIAL SETUP:**Tools and Special Tools**

Tool Kit, General Mechanic's: Automotive
(Volume 5, WP 0826, Table 1, Item 56)

Personnel Required

(2)

References

Volume 3, WP 0522
Volume 3, WP 0523

References (cont.)

Volume 3, WP 0525
Volume 3, WP 0526
Volume 3, WP 0527
Volume 3, WP 0528

Equipment Condition

Vehicle parked and engine shut down.
(TM 9-2320-272-10)

TROUBLESHOOTING PROCEDURE**LOOSE SPARE TIRE CARRIER****NOTE**

Conduct these malfunction tests if the spare tire carrier is loose. This procedure will check for loose mounting hardware and damage to the carrier.

LOOSE SPARE TIRE CARRIER - Continued**STEP****1. IS THE SPARE TIRE CARRIER IN GOOD OPERATING CONDITION?**

Check spare tire carrier for damage and loose, damaged, or missing hardware.

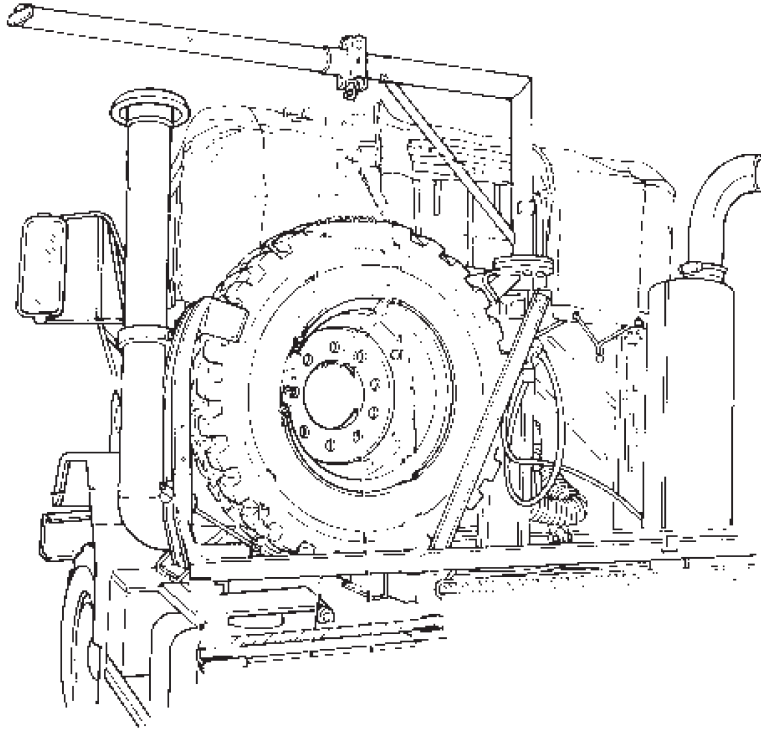

T0572DAA

Figure 1. Spare Tire Carrier.

LOOSE SPARE TIRE CARRIER - Continued

Figure 2. Spare Tire Carrier Assembly.

CONDITION/INDICATION

IS THE SPARE TIRE CARRIER IN GOOD OPERATING CONDITION?

DECISION

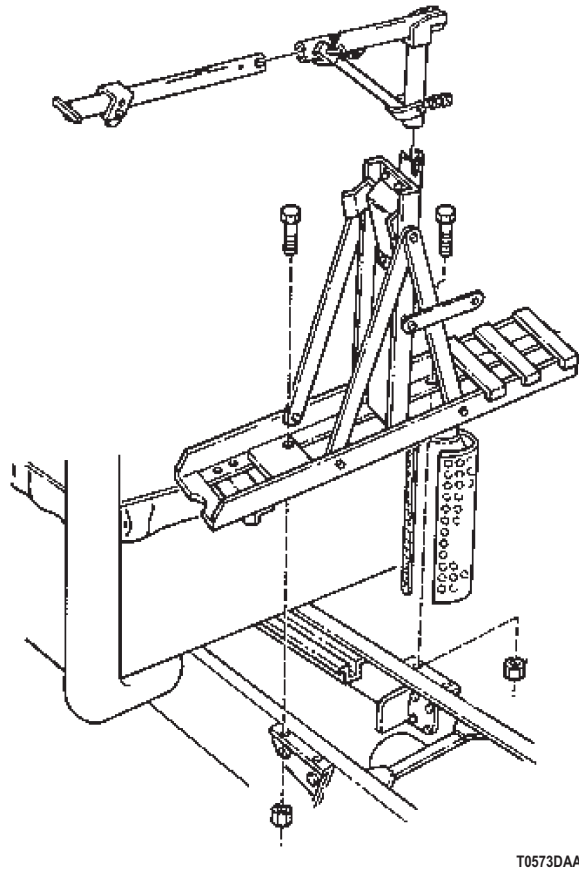
NO - Repair or replace tractor spare tire carrier (M931 and M932) (Volume 3, WP 0522). Go to Step (2) to verify problem is solved.

NO - Repair or replace tractor spare tire carrier (M931A1/A2 and M932A1/A2) (Volume 3, WP 0523). Go to Step (2) to verify problem is solved.

NO - Repair or replace dump and van spare tire carrier (M929, M930, M934) (Volume 3, WP 0525). Go to Step (2) to verify problem is solved.

NO - Repair or replace dump and van spare tire carrier (M929A1/A2, M930A1/A2, M934A1/A2) (Volume 3, WP 0526). Go to Step (2) to verify problem is solved.

NO - Repair or replace cargo spare tire carrier (M923, M925, M927, M928) (Volume 3, WP 0527). Go to Step (2) to verify problem is solved.

NO - Repair or replace cargo spare tire carrier (M923A1/A2, M925A1/A2, M927A1/A2, M928A1/A2) (Volume 3, WP 0528). Go to Step (2) to verify problem is solved.

YES - Go to Step (2) to verify problem is solved.

LOOSE SPARE TIRE CARRIER - Continued**STEP**

2. IS YOUR ORIGINAL SPARE TIRE CARRIER PROBLEM STILL PRESENT?
 - a. Ensure vehicle is returned to normal operating condition.
 - b. Check to see if your original spare tire carrier problem still exists.

CONDITION/INDICATION

IS YOUR ORIGINAL SPARE TIRE CARRIER PROBLEM STILL PRESENT?

DECISION

YES - Notify supervisor.
NO - Problem fixed.

END OF WORK PACKAGE

FIELD MAINTENANCE
UNEVEN TIRE WEAR

INITIAL SETUP:**Tools and Special Tools**

Tool Kit, General Mechanic's: Automotive
(Volume 5, WP 0826, Table 1, Item 56)
High Boy Jack Stands
(Volume 5, WP 0826, Table 1, Item 24)

Personnel Required

(2)

References

Point to Point Schematics
Volume 3, WP 0479

References (cont.)

Volume 3, WP 0480
Volume 3, WP 0481
Volume 3, WP 0482
Volume 3, WP 0483
Volume 3, WP 0484
Volume 3, WP 0485
Volume 3, WP 0493

Equipment Condition

Vehicle parked and engine shut down.
(TM 9-2320-272-10)

TROUBLESHOOTING PROCEDURE**UNEVEN TIRE WEAR****NOTE**

Conduct these malfunction tests if there is evidence of uneven tire wear. This procedure will check for loose or missing wheel lug nuts, improper toe-in adjustment and wheel bearing looseness or damage.

UNEVEN TIRE WEAR - Continued**STEP****1. ARE THERE ANY LOOSE OR MISSING WHEEL LUG NUTS?**

Visually check for loose or missing wheel lug nuts.

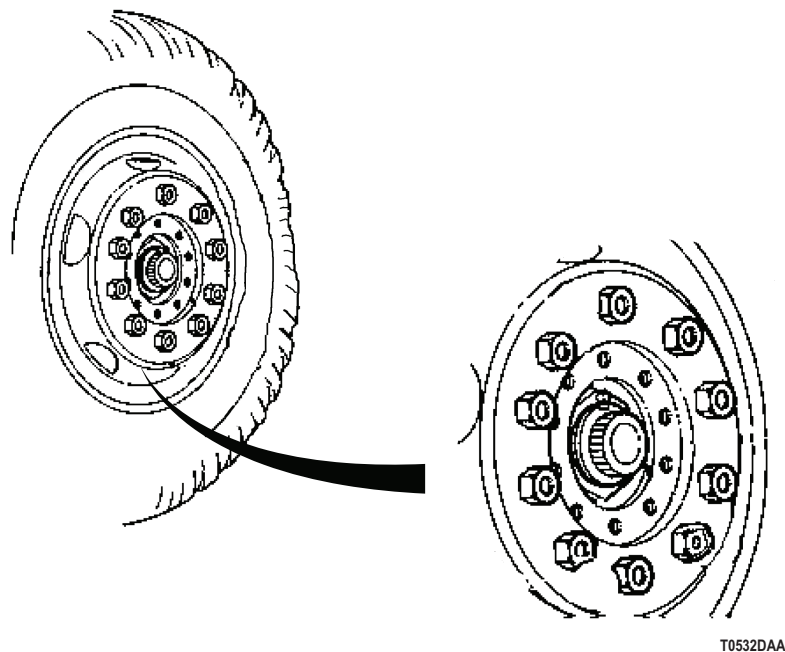

Figure 1. Lugnuts.

CONDITION/INDICATION

ARE THERE ANY LOOSE OR MISSING WHEEL LUG NUTS?

DECISION

YES - Tighten or replace wheel lug nuts M939 (Volume 3, WP 0484), M939A1/A2 (Volume 3, WP 0485). Go to Step (4) to verify problem is solved.

NO - Go to Step (2).

UNEVEN TIRE WEAR - Continued**STEP**

2. IS FRONT TIRE TOE-IN ADJUSTMENT CORRECT?
 - a. Check front tires for proper toe-in adjustment.
 - b. Follow toe-in check procedure (Volume 3, WP 0493).

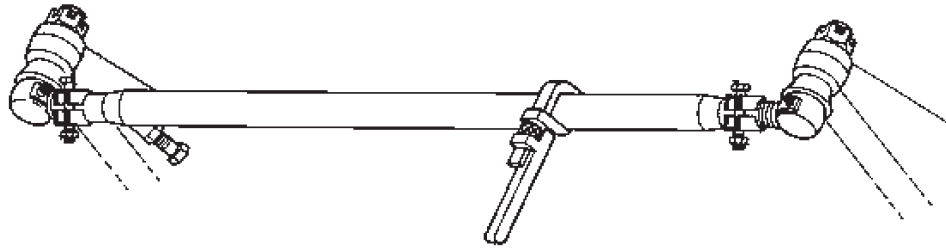

T0533DAA

Figure 2. Toe-In Adjustment.

CONDITION/INDICATION

IS FRONT TIRE TOE-IN ADJUSTMENT CORRECT?

DECISION

YES - Go to Step (3).

NO - Adjust front tires toe-in (Volume 3, WP 0493). Go to Step (4) to verify problem is solved.

UNEVEN TIRE WEAR - Continued**STEP**

3. ARE WHEEL BEARINGS IN GOOD OPERATING CONDITION?
 - a. Visually check wheel bearings for proper adjustment or damage.

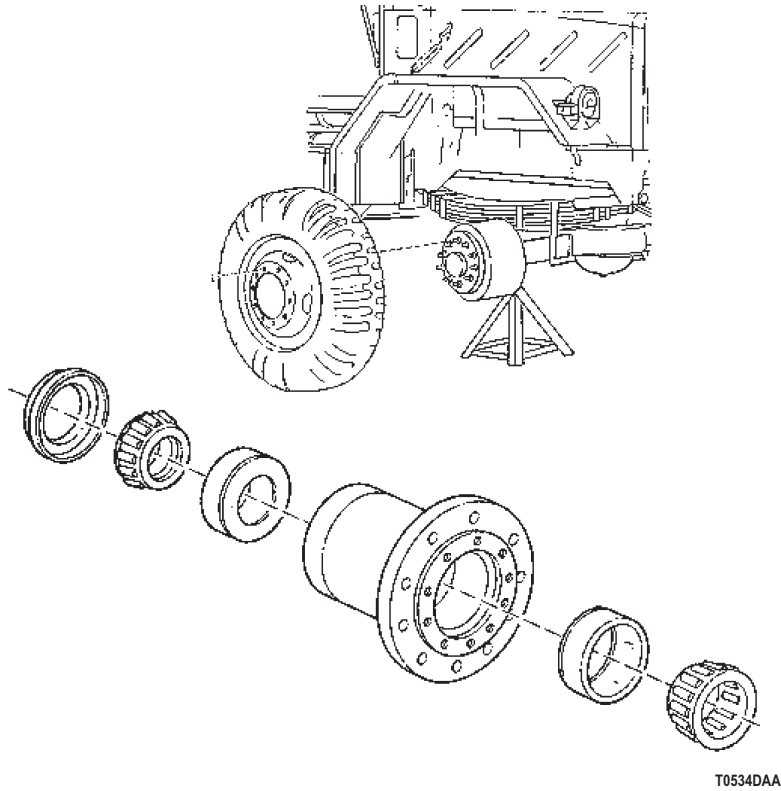

Figure 3. Wheel Bearing Assembly.

- b. Raise vehicle wheels until they are off the ground M939 (Volume 3, WP 0484), M939A1/A2 (Volume 3, WP 0485) .

NOTE

Excessive play indicates improperly adjusted or damaged bearings.

- c. Lift up on bottom of tire using a prybar to determine bearing play.

UNEVEN TIRE WEAR - Continued**CONDITION/INDICATION**

ARE WHEEL BEARINGS IN GOOD OPERATING CONDITION?

DECISION

NO - Moderate play, adjustment required. Adjust wheel bearing(s) (Volume 3, WP 0483). Go to Step (4) to verify problem is solved.

NO - Excessive play, front wheel bearing damage. Replace damaged wheel bearings

M939/A1 (Volume 3, WP 0479), M939/A2 (Volume 3, WP 0481). Go to Step (4) to verify problem is solved.

NO - Excessive play, rear wheel bearing damaged. Replace rear wheel bearings

M939/A1 (Volume 3, WP 0480), M939/A2 (Volume 3, WP 0482). Go to Step (4) to verify problem is solved.

YES - Go to Step (4) to verify problem is solved.

STEP

4. IS YOUR ORIGINAL UNEVEN TIRE WEAR PROBLEM STILL PRESENT?
 - a. Ensure vehicle is returned to normal operating condition.
 - b. Check to see if your uneven tire wear problem still exists.

CONDITION/INDICATION

IS YOUR ORIGINAL UNEVEN TIRE WEAR PROBLEM STILL PRESENT?

DECISION

YES - Notify supervisor.

NO - Problem fixed.

END OF WORK PACKAGE

**FIELD MAINTENANCE
WHEEL SHIMMY OR WOBBLE**

INITIAL SETUP:**Tools and Special Tools**

Tool Kit, General Mechanic's: Automotive
(Volume 5, WP 0826, Table 1, Item 56)

Personnel Required

(2)

References

Point to Point Schematics
Volume 3, WP 0479
Volume 3, WP 0480

References (cont.)

Volume 3, WP 0481
Volume 3, WP 0482
Volume 3, WP 0483
Volume 3, WP 0484
Volume 3, WP 0485

Equipment Condition

Vehicle parked and engine shut down.
(TM 9-2320-272-10)

TROUBLESHOOTING PROCEDURE**WHEEL SHIMMY OR WOBBLE****NOTE**

Conduct these malfunction tests if a wheel shimmy or wobble is detected. This procedure will check for damage to the wheels or wheel bearings.

WHEEL SHIMMY OR WOBBLE - Continued**STEP****1. ARE VEHICLE WHEELS IN GOOD OPERATING CONDITION?**

Visually check wheels for bends or damage.

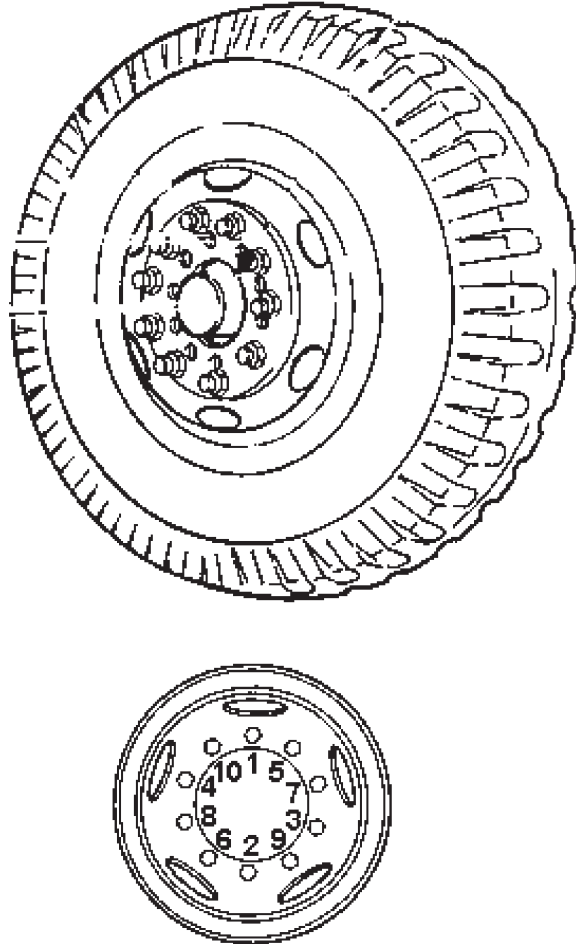

T0536DAA

Figure 1. Wheel.

CONDITION/INDICATION

ARE VEHICLE WHEELS IN GOOD OPERATING CONDITION?

DECISION

NO - Replace bent or damaged wheels M939 (Volume 3, WP 0484), M939A1/A2 (Volume 3, WP 0485). Go to Step (3) to verify problem is solved.

YES - Go to Step (2).

STEP**2. ARE WHEEL BEARINGS IN GOOD OPERATING CONDITION?**

WHEEL SHIMMY OR WOBBLE - Continued

- a. Visually check front and rear wheel bearings for proper adjustment and damage.

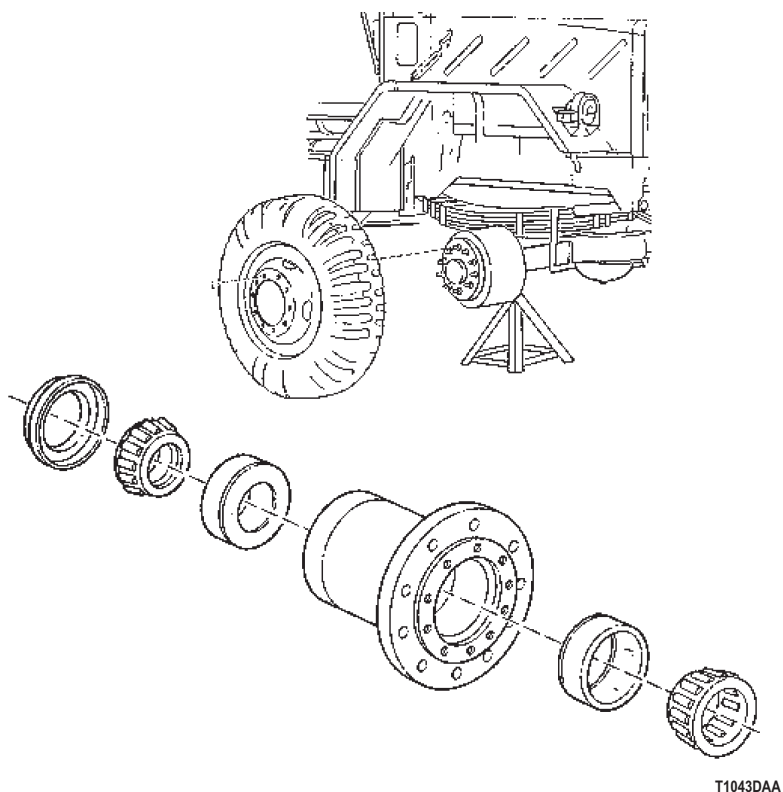

Figure 2. Wheel Bearing Assembly.

- b. Raise vehicle wheels until they are off the ground M939 (Volume 3, WP 0484), M939A1/A2 (Volume 3, WP 0485).

NOTE

Excessive play indicates improperly adjusted or damaged bearings.

- c. Use prybar to lift up on bottom of tire to determine bearing play. Excessive play indicates improperly adjusted or damaged bearings.

CONDITION/INDICATION

ARE WHEEL BEARINGS IN GOOD OPERATING CONDITION?

DECISION

NO - Moderate play, adjustment required. Adjust wheel bearing(s) (Volume 3, WP 0483). Go to Step (3) to verify problem is solved.

NO - Excessive play, front wheel bearings damaged. Replace damaged wheel bearings M939/A1 (Volume 3, WP 0479), M939/A2 (Volume 3, WP 0481). Go to Step (3) to verify problem is solved.

NO - Excessive play, rear wheel bearings damaged. Replace rear wheel bearings M939/A1 (Volume 3, WP 0480), M939/A2 (Volume 3, WP 0482). Go to Step (3) to verify problem is solved.

YES - Go to Step (3) to verify problem is solved.

WHEEL SHIMMY OR WOBBLE - Continued**STEP**

3. IS YOUR ORIGINAL WHEEL SHIMMY OR WOBBLE PROBLEM STILL PRESENT?
 - a. Ensure vehicle is returned to normal operating condition.
 - b. Check to see if your wheel shimmy or wobble problem still exists.

CONDITION/INDICATION

IS YOUR ORIGINAL WHEEL SHIMMY OR WOBBLE PROBLEM STILL PRESENT?

DECISION

YES - Notify supervisor.
NO - Problem fixed.

END OF WORK PACKAGE

FIELD MAINTENANCE HARD STEERING

INITIAL SETUP:**Tools and Special Tools**

Tool Kit, General Mechanic's: Automotive
(Volume 5, WP 0826, Table 1, Item 56)
High Boy Jack Stands
(Volume 5, WP 0826, Table 1, Item 24)

Personnel Required

(2)

References

Point to Point Schematics
Volume 3, WP 0484
Volume 3, WP 0485
Volume 3, WP 0492

References (cont.)

Volume 3, WP 0493
Volume 3, WP 0496
Volume 3, WP 0501
Volume 3, WP 0505
Volume 3, WP 0506
Volume 3, WP 0507
Volume 3, WP 0508
Volume 3, WP 0534
Volume 5, WP 0820

Equipment Condition

Vehicle parked and engine shut down.
(TM 9-2320-272-10)

TROUBLESHOOTING PROCEDURE**HARD STEERING****NOTE**

Conduct these malfunction tests if vehicle steering becomes hard. This procedure will check for loose or leaking hydraulic lines and hoses, steering linkage damage, binding steering knuckles, loose U-bolts and incorrect front wheel alignment.

HARD STEERING - Continued**STEP****1. ARE ALL HYDRAULIC LINES AND HOSES IN GOOD CONDITION?**

Visually inspect all hydraulic lines and hoses for leaks.

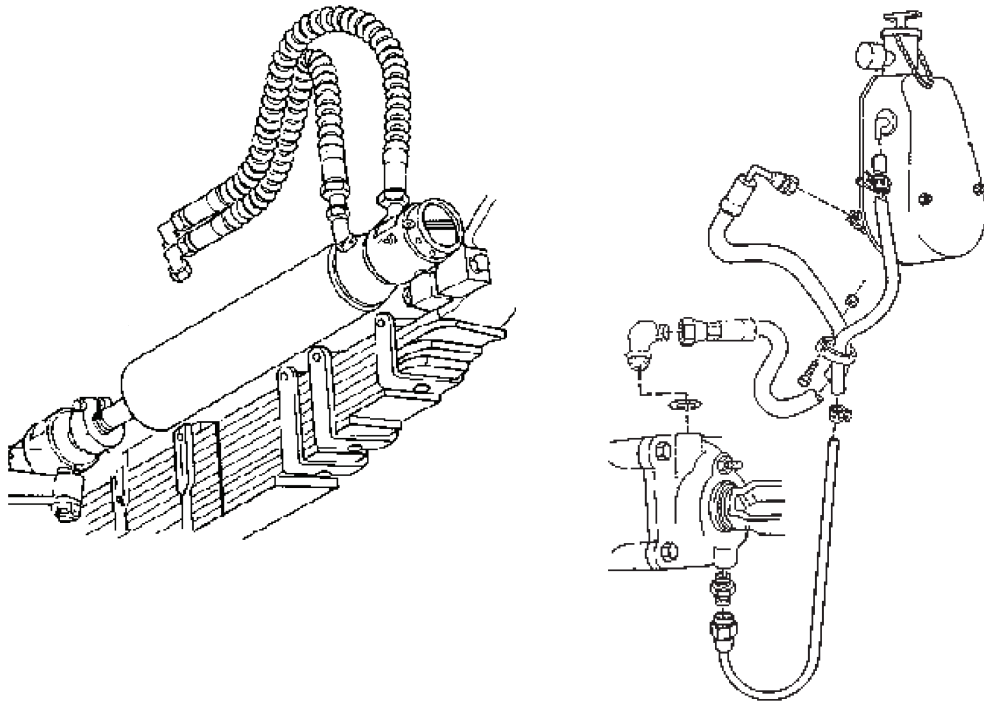

T1019DAA

Figure 1. Steering Hydraulic Lines.

CONDITION/INDICATION

ARE ALL HYDRAULIC LINES AND HOSES IN GOOD CONDITION?

DECISION

NO - Steering assist cylinder hoses damaged. Replace damaged hoses (Volume 3, WP 0507). Go to Step (6) to verify problem is solved.

NO - Steering pump pressure and return hoses damaged (Ross). Replace damaged hoses (Volume 3, WP 0505). Go to Step (6) to verify problem is solved.

NO - Steering pump pressure and return hoses damaged (Sheppard). Replace damaged hoses (Volume 3, WP 0506). Go to Step (6) to verify problem is solved.

NO - Steering gear to assist cylinder pressure lines damaged. Replace damaged pressure lines (Volume 3, WP 0508). Go to Step (6) to verify problem is solved.

YES - Go to Step (2).

HARD STEERING - Continued**STEP****2. IS STEERING LINKAGE IN GOOD OPERATING CONDITION?**

Visually inspect steering linkage for binding, damage, and improper lubrication.

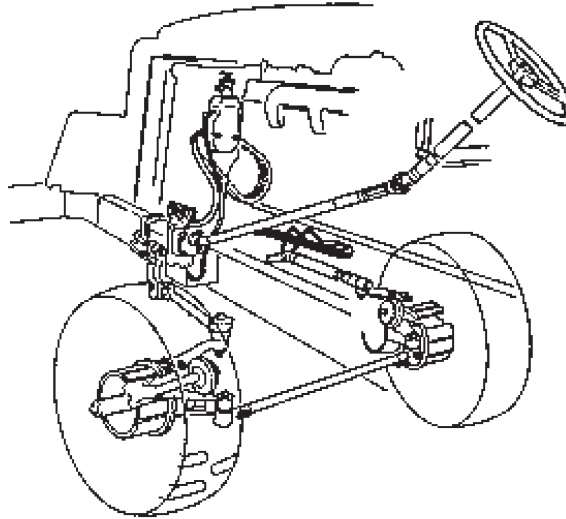

T1020DAA

Figure 2. Steering Assembly.

CONDITION/INDICATION

IS STEERING LINKAGE IN GOOD OPERATING CONDITION?

DECISION

NO - Pitman arm damaged (Ross). Repair or replace as necessary (Volume 3, WP 0496). Go to Step (6) to verify problem is solved.

NO - Pitman arm damaged (Sheppard). Repair or replace as necessary (Volume 3, WP 0501). Go to Step (6) to verify problem is solved.

NO - Drag link damaged. Replace damaged drag link (Volume 3, WP 0492). Go to Step (6) to verify problem is solved.

NO - Steering linkage improperly lubricated. Lubricate steering linkage (Volume 5, WP 0820). Go to Step (6) to verify problem is solved.

YES - Go to Step (3).

HARD STEERING - Continued**STEP****3. ARE STEERING KNUCKLES IN GOOD CONDITION?**

- a. Raise front vehicle wheels until they are off the ground M939 (Volume 3, WP 0484), M939A1/A2 (Volume 3, WP 0485).

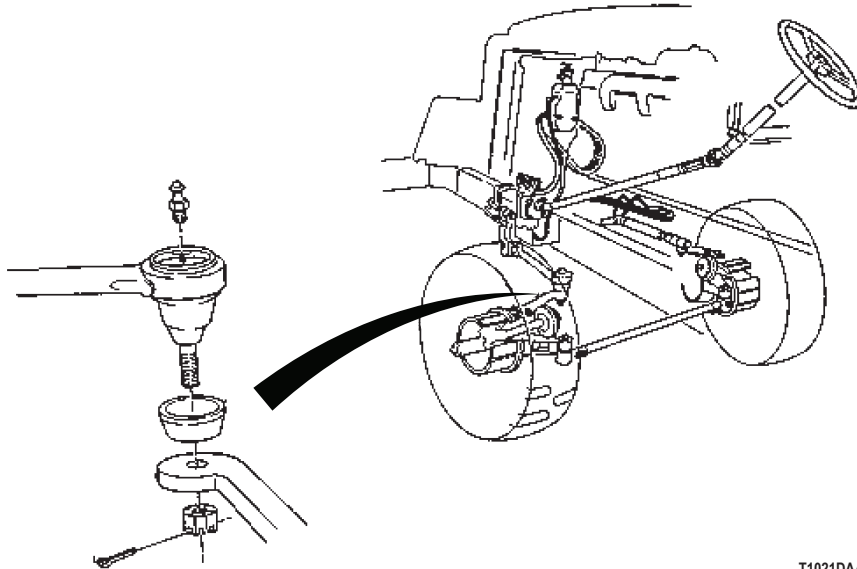

T1021DAA

Figure 3. Pitman Arm.

- b. Disconnect drag link at pitman arm (Volume 3, WP 0496).

NOTE

If binding occurs, steering knuckles may be faulty

- c. Turn wheels from side to side to determine if there is binding.

CONDITION/INDICATION

ARE STEERING KNUCKLES IN GOOD CONDITION?

DECISION

NO - Notify supervisor. Action may not be possible for this level of maintenance.
YES - Go to Step (4).

HARD STEERING - Continued**STEP****4. ARE SPRING U-BOLTS IN GOOD WORKING CONDITION?**

Visually check spring U-bolts for damage and looseness.

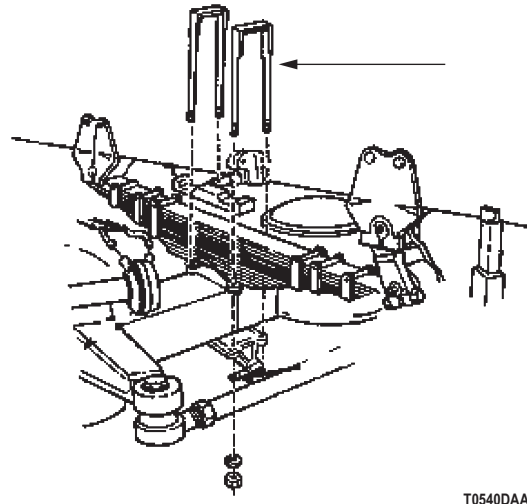

Figure 4. Spring U-Bolts.

CONDITION/INDICATION

ARE SPRING U-BOLTS IN GOOD WORKING CONDITION?

DECISION

NO - Tighten or replace damaged U-bolts (Volume 3, WP 0534). Go to Step (6) to verify problem is solved.
YES - Go to Step (5).

HARD STEERING - Continued**STEP**

5. IS FRONT WHEEL ALIGNMENT PROPERLY ADJUSTED?
 - a. Make sure tires are evenly inflated to proper pressure.

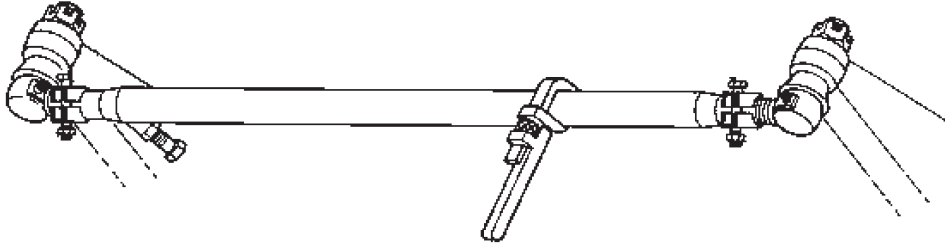

T1022DAA

Figure 5. Toe-In Check.

- b. Check front wheel alignment settings (toe in check) (Volume 3, WP 0493).

CONDITION/INDICATION

IS FRONT WHEEL ALIGNMENT PROPERLY ADJUSTED?

DECISION

NO - Adjust alignment to proper setting (Volume 3, WP 0493). Go to Step (6) to verify problem is solved.
 YES - Go to Step (6) to verify problem is solved.

STEP

6. IS YOUR ORIGINAL STEERING PROBLEM STILL PRESENT?
 - a. Ensure vehicle is returned to normal operating condition.
 - b. Check to see if your original steering problem still exists.

CONDITION/INDICATION

IS YOUR ORIGINAL STEERING PROBLEM STILL PRESENT?

DECISION

YES - Notify supervisor.
 NO - Problem fixed.

END OF WORK PACKAGE

**FIELD MAINTENANCE
VEHICLE WANDERS OR PULLS TO ONE SIDE**

INITIAL SETUP:**Tools and Special Tools**

Tool Kit, General Mechanic's: Automotive
(Volume 5, WP 0826, Table 1, Item 56)
High Boy Jack Stands
(Volume 5, WP 0826, Table 1, Item 24)
Wrench, Torque, Click, Ratcheting, 3/4" Drive,
600 Ft-Lb
(Volume 5, WP 0826, Table 1, Item 61)

Personnel Required

(2)

References

Point to Point Schematics
TM 9-2320-272-10
WP 0119
WP 0121
Volume 3, WP 0479

References (cont.)

Volume 3, WP 0480
Volume 3, WP 0481
Volume 3, WP 0482
Volume 3, WP 0483
Volume 3, WP 0484
Volume 3, WP 0485
Volume 3, WP 0493
Volume 3, WP 0496
Volume 3, WP 0499
Volume 3, WP 0500
Volume 3, WP 0501
Volume 3, WP 0510
Volume 3, WP 0535

Equipment Condition

Vehicle parked and engine shut down.
(TM 9-2320-272-10)

TROUBLESHOOTING PROCEDURE**VEHICLE WANDERS OR PULLS TO ONE SIDE****NOTE**

Conduct these malfunction tests if vehicle wanders or pulls to one side. This procedure will check front tires for uneven tire pressure and underinflation, uneven tire wear indicating alignment problem and dragging brakes.

VEHICLE WANDERS OR PULLS TO ONE SIDE - Continued**STEP**

1. ARE FRONT TIRES PROPERLY AND EVENLY INFLATED?

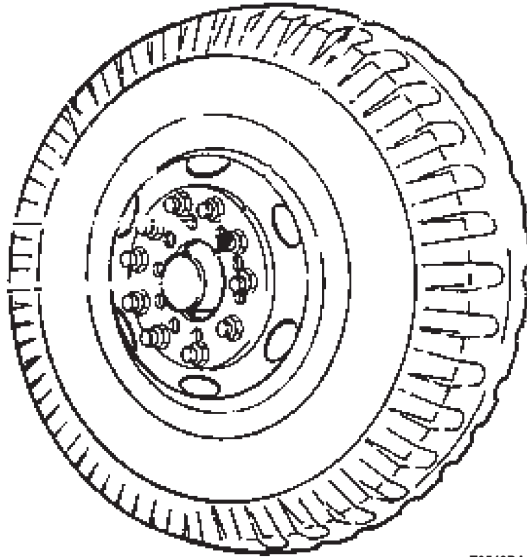

T0543DAA

Figure 1. Tire.

Check front tires for underinflation and uneven tire pressure.

CONDITION/INDICATION

ARE FRONT TIRES PROPERLY AND EVENLY INFLATED?

DECISION

YES - Go to Step (2).

NO - Inflate tires to proper pressure (TM 9-2320-272-10). Go to Step (11) to verify problem is solved.

VEHICLE WANDERS OR PULLS TO ONE SIDE - Continued**STEP****2. IS THERE UNEVEN WEAR BETWEEN FRONT TIRES?**

Visually check front tires for uneven wear.

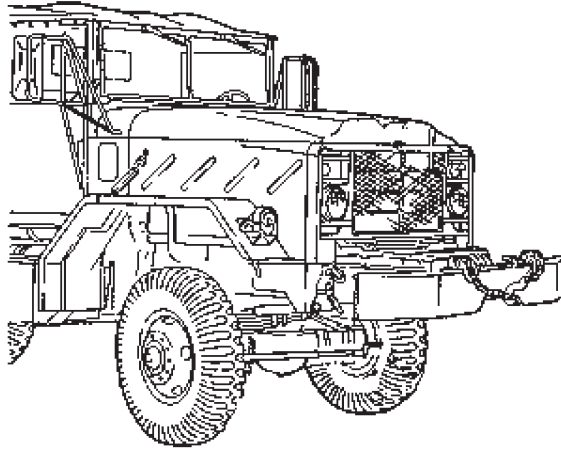

T0544DAA

Figure 2. Front Wheel Assembly.

CONDITION/INDICATION

IS THERE UNEVEN WEAR BETWEEN FRONT TIRES?

DECISION

YES - Adjust front wheel alignment (toe-in) (Volume 3, WP 0493). Go to Step (11) to verify problem is solved.
NO - Go to Step (3).

VEHICLE WANDERS OR PULLS TO ONE SIDE - Continued

STEP

- 3. ARE BRAKES DRAGGING?
 - a. Check for dragging brakes.

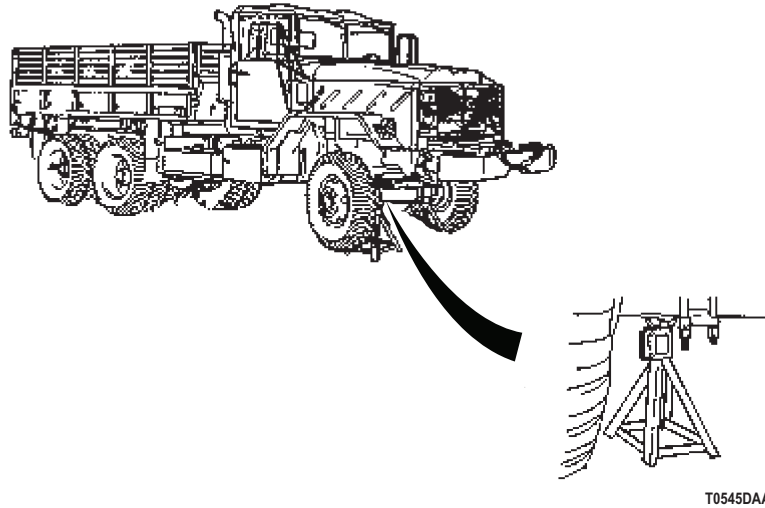

Figure 3. Truck Jack.

- b. Raise vehicle wheels until they are off the ground M939 (Volume 3, WP 0484), M939A1/A2 (Volume 3, WP 0485).

NOTE

Wheels should turn with slight drag when brakes are properly adjusted.

- c. Spin wheel by hand.

CONDITION/INDICATION

ARE BRAKES DRAGGING?

DECISION

- NO - Go to Step (4).
- YES - Perform Vehicle Pulls Right or Left When Applying Brakes troubleshooting (WP 0121).

STEP

- 4. ARE WHEEL BEARINGS IN GOOD OPERATING CONDITION?
 - a. Visually check front and rear wheel bearing for adjustment and damage.

VEHICLE WANDERS OR PULLS TO ONE SIDE - Continued

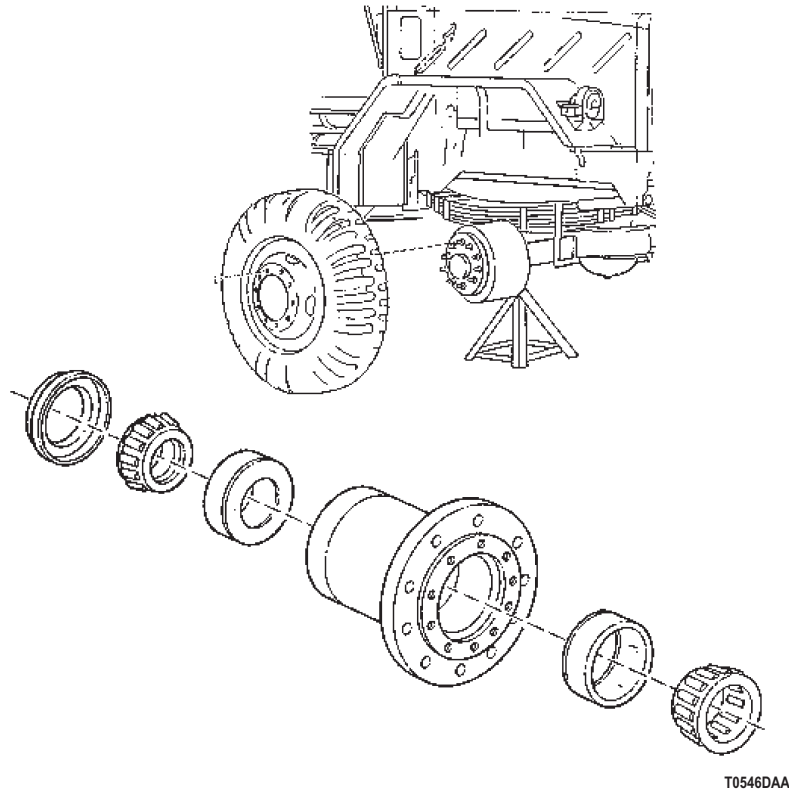

Figure 4. Wheel Bearing Assembly.

- b. Raise vehicle wheels until they are off the ground M939 (Volume 3, WP 0484), M939A1/A2 (Volume 3, WP 0485).

NOTE

Excessive play indicates improperly adjusted or damaged bearings.

- c. Lift up on bottom of tire using a prybar to determine bearing play.

CONDITION/INDICATION

ARE WHEEL BEARINGS IN GOOD OPERATING CONDITION?

DECISION

NO - Moderate play, adjustment required. Adjust wheel bearings (Volume 3, WP 0483). Go to Step (11) to verify problem is solved.

NO - Excessive play at front wheel. Replace damaged wheel bearings M939/A1 (Volume 3, WP 0479), M939A2 (Volume 3, WP 0481). Go to Step (11) to verify problem is solved.

NO - Excessive play at rear wheel. Replace rear wheel bearings M939/A1 (Volume 3, WP 0480), M939A2 (Volume 3, WP 0482). Go to Step (11) to verify problem is solved.

YES - Little or no play, wheel bearings OK. Go to Step (5).

VEHICLE WANDERS OR PULLS TO ONE SIDE - Continued**STEP****5. IS STEERING ASSIST CYLINDER IN GOOD OPERATING CONDITION?**

Check steering assist cylinder for damage and improper adjustment (Volume 3, WP 0510).

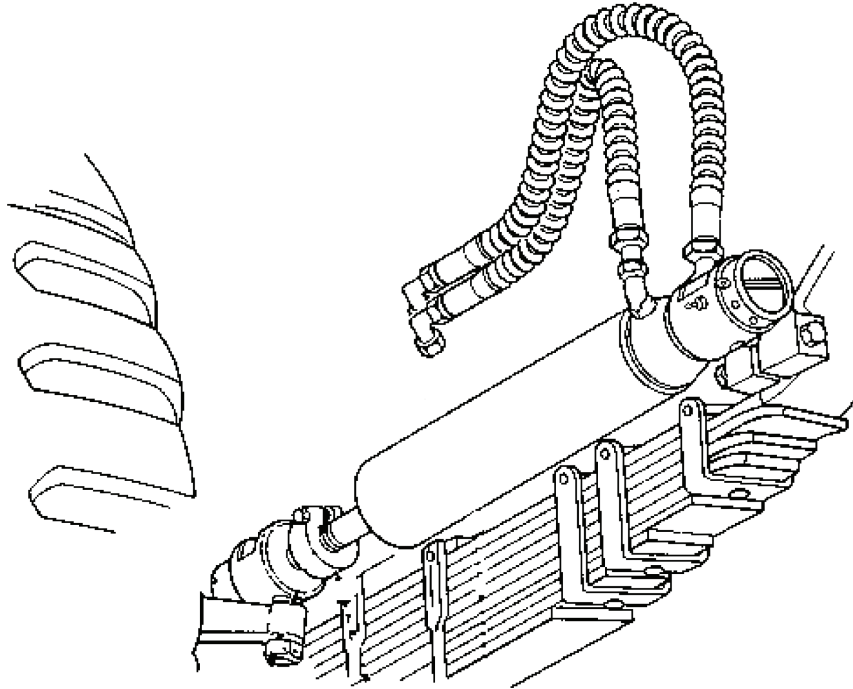

T0547DAA

Figure 5. Steering Assist Cylinder.

CONDITION/INDICATION

IS STEERING ASSIST CYLINDER IN GOOD OPERATING CONDITION?

DECISION

YES - Go to Step (6).

NO - Adjust or replace steering assist cylinder (Volume 3, WP 0510). Go to Step (11) to verify problem is solved.

VEHICLE WANDERS OR PULLS TO ONE SIDE - Continued**STEP****6. IS TIE ROD IN GOOD OPERATING CONDITION?**

Visually check tie rod for looseness, bends, cracks and stripped threads (Volume 3, WP 0493).

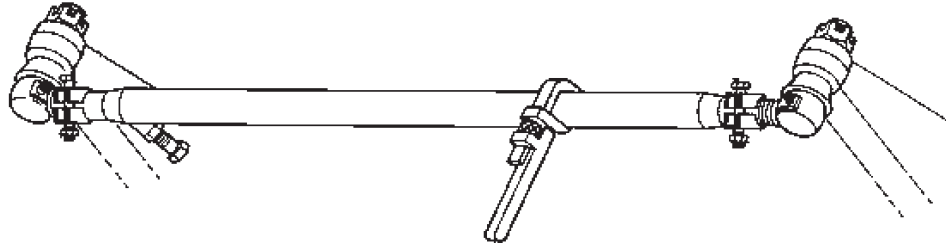

T1023DAA

Figure 6. Tie Rod.

CONDITION/INDICATION

IS TIE ROD IN GOOD OPERATING CONDITION?

DECISION

YES - Go to Step (7).

NO - Tighten or replace tie rod (Volume 3, WP 0493). Go to Step (11) to verify problem is solved.

VEHICLE WANDERS OR PULLS TO ONE SIDE - Continued**STEP**

7. DOES VEHICLE STEER PROPERLY AFTER TIGHTENING STEERING GEAR MOUNTING BOLTS?
- a. Visually check for loose or missing steering gear mounting bolts.

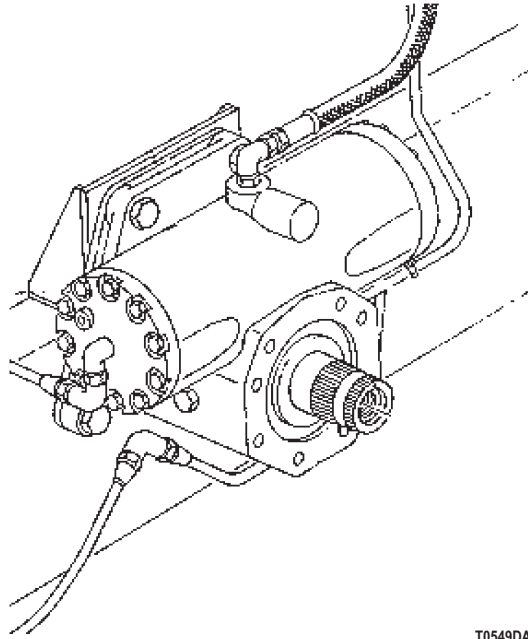

T0549DAA

Figure 7. Steering Gear.

- b. Replace any missing mounting bolts (Ross) (Volume 3, WP 0499), (Sheppard) (Volume 3, WP 0500).
- c. Tighten mounting bolts to 260-280 ft-lb (353-380 N-m).
- d. Ensure vehicle is returned to normal operating condition.
- e. Check to see if your original vehicle wanders or pulls problem still exists.

CONDITION/INDICATION

DOES VEHICLE STEER PROPERLY AFTER TIGHTENING STEERING GEAR MOUNTING BOLTS?

DECISION

YES - Go to Step (11) to verify problem is solved.
NO - Go to Step (8).

VEHICLE WANDERS OR PULLS TO ONE SIDE - Continued**STEP****8. IS PITMAN ARM IN GOOD OPERATING CONDITION?**

Visually check pitman arm for wear and damage.

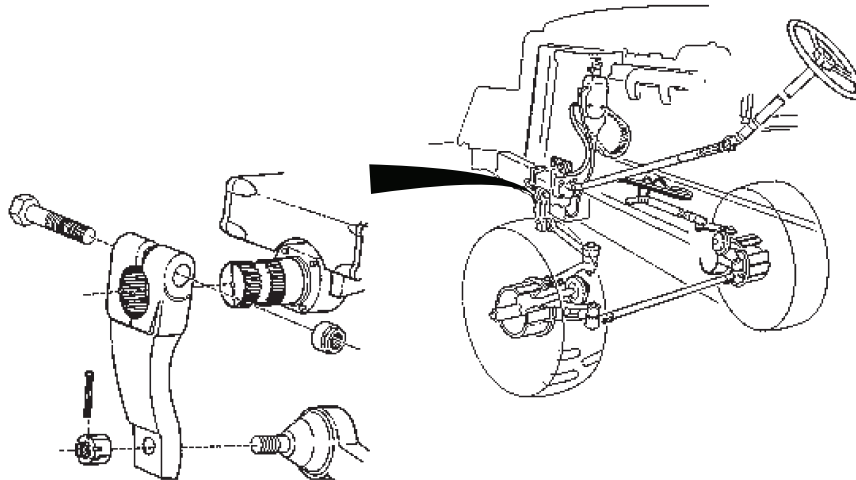

T0550DAA

Figure 8. Pitman Arm.

CONDITION/INDICATION

IS PITMAN ARM IN GOOD OPERATING CONDITION?

DECISION

YES - Go to Step (9).

NO - Replace worn pitman arm (Ross) (Volume 3, WP 0496), (Sheppard) (Volume 3, WP 0501). Go to Step (11) to verify problem is solved.

VEHICLE WANDERS OR PULLS TO ONE SIDE - Continued**STEP****9. ARE FRONT SPRING SHACKLE PINS IN GOOD CONDITION?**

Visually check front spring shackle pins for wear or damage.

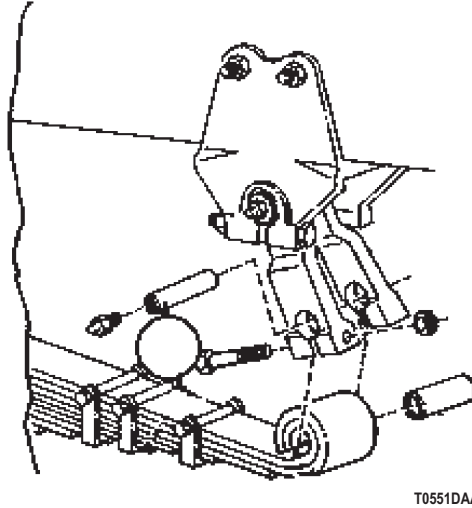

Figure 9. Shackle Pins.

CONDITION/INDICATION

ARE FRONT SPRING SHACKLE PINS IN GOOD CONDITION?

DECISION

YES - Go to Step (10).

NO - Replace worn or damaged shackle pins (Volume 3, WP 0535). Go to Step (11) to verify problem is solved.

VEHICLE WANDERS OR PULLS TO ONE SIDE - Continued**STEP****10. IS FRONT TIRE TOE-IN ADJUSTMENT CORRECT?**

Check front tires for proper toe-in adjustment (Volume 3, WP 0493).

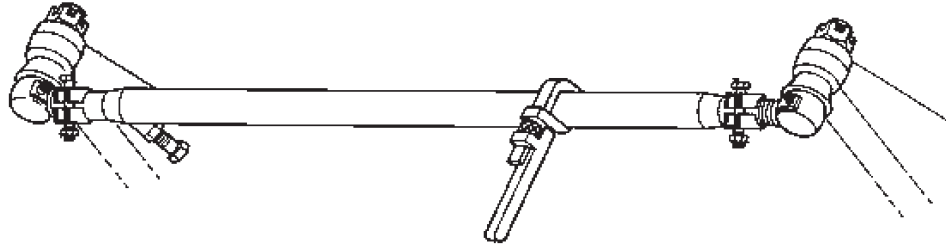

T0541DAA

Figure 10. Toe-In Check.

CONDITION/INDICATION

IS FRONT TIRE TOE-IN ADJUSTMENT CORRECT?

DECISION

YES - Go to Step (11) to verify problem is solved.

NO - Adjust front tires toe-in (Volume 3, WP 0493). Go to Step (11) to verify problem is solved.

STEP**11. IS YOUR ORIGINAL VEHICLE WANDERS OR PULLS PROBLEM STILL PRESENT?**

- a. Ensure vehicle is returned to normal operating condition.
- b. Check to see if your original vehicle wanders or pulls problem still exists.

CONDITION/INDICATION

IS YOUR ORIGINAL VEHICLE WANDERS OR PULLS PROBLEM STILL PRESENT?

DECISION

YES - Notify supervisor.

NO - Problem fixed.

END OF WORK PACKAGE

**FIELD MAINTENANCE
EXCESSIVE PLAY IN STEERING WHEEL**

INITIAL SETUP:**Tools and Special Tools**

Tool Kit, General Mechanic's: Automotive
(Volume 5, WP 0826, Table 1, Item 56)

Personnel Required

(2)

References

Point to Point Schematics
Volume 3, WP 0492

References (cont.)

Volume 3, WP 0493
Volume 3, WP 0496
Volume 3, WP 0501
Volume 3, WP 0510

Equipment Condition

Vehicle parked and engine shut down.
(TM 9-2320-272-10)

TROUBLESHOOTING PROCEDURE**EXCESSIVE PLAY IN STEERING WHEEL****NOTE**

Conduct these malfunction tests if there is excessive play in the steering wheel. This procedure will check steering wheel free play, drag link for looseness and damage, tie rod for damage and loose ends, pitman arm for damage, and steering assist cylinder for improper adjustment and damage.

EXCESSIVE PLAY IN STEERING WHEEL - Continued**STEP**

1. DOES STEERING WHEEL HAVE EXCESSIVE PLAY?
 - a. Check steering wheel free play.

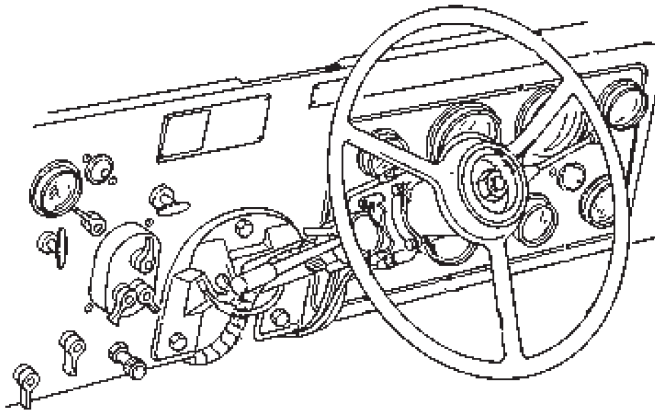

T0554DAA

Figure 1. Steering Wheel.

- b. With engine running, place stiff wire against dash that's long enough to touch the steering wheel rim.
- c. Turn steering wheel left then right until there is resistance.
- d. Mark the points on the steering wheel where the travel ends.
- e. Measure the distance between these two points. Distance should be less than 2 1/2 in. (6.3 cm).

CONDITION/INDICATION

DOES STEERING WHEEL HAVE EXCESSIVE PLAY?

DECISION

- YES - Go to Step (2).
NO - Go to Step (6) to verify problem is solved.

EXCESSIVE PLAY IN STEERING WHEEL - Continued**STEP****2. IS DRAG LINK IN GOOD OPERATING CONDITION?**

Visually check drag link for looseness and damage.

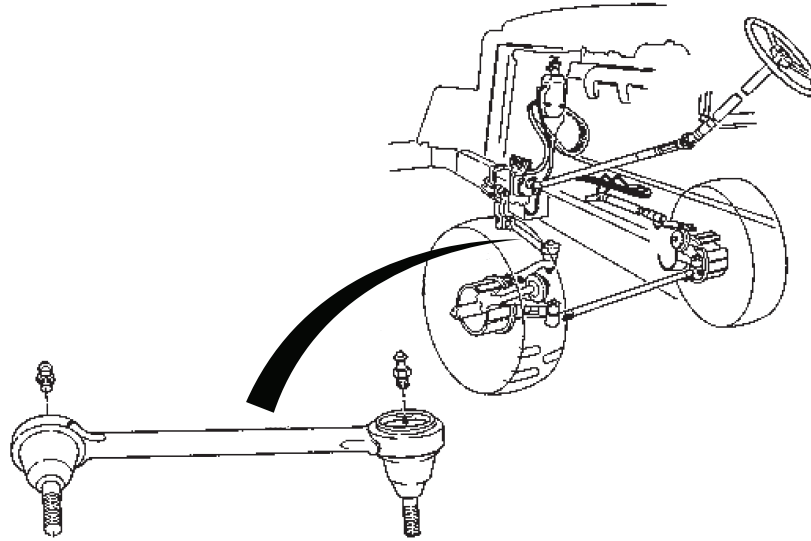

T0555DAA

Figure 2. Drag Link.

CONDITION/INDICATION

IS DRAG LINK IN GOOD OPERATING CONDITION?

DECISION

YES - Go to Step (3).

NO - Tighten or replace drag link (Volume 3, WP 0492). Go to Step (6) to verify problem is solved.

EXCESSIVE PLAY IN STEERING WHEEL - Continued**STEP**

3. IS TIE ROD IN GOOD OPERATING CONDITION?
 - a. Visually inspect tie rod for damage and loose ends.

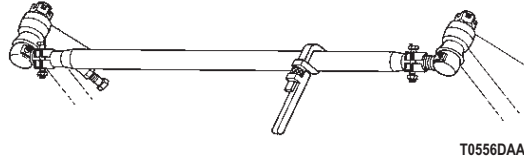

Figure 3. Tie Rod.

NOTE

No free play is allowable.

- b. Check for any free play at tie rod connections.

CONDITION/INDICATION

IS TIE ROD IN GOOD OPERATING CONDITION?

DECISION

YES - Go to Step (4).

NO - Tighten or replace tie rod (Volume 3, WP 0493). Go to Step (6) to verify problem is solved.

EXCESSIVE PLAY IN STEERING WHEEL - Continued**STEP****4. IS PITMAN ARM IN GOOD OPERATING CONDITION?**

Visually check pitman arm for damage.

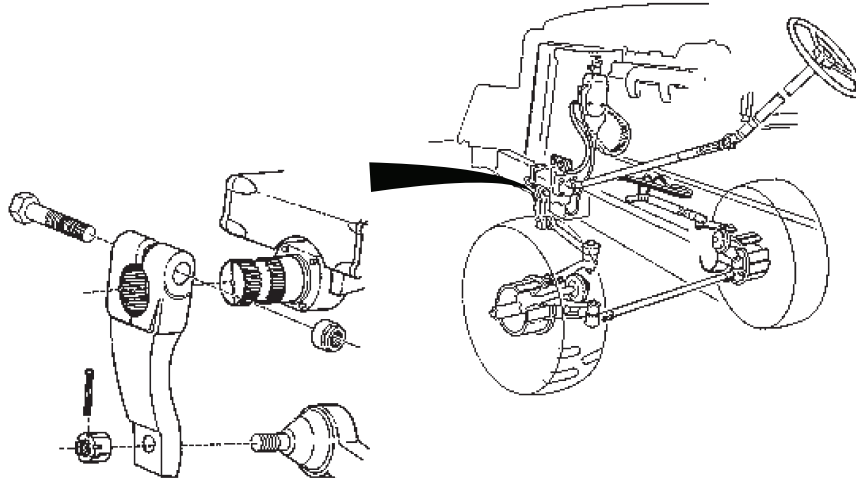

T0557DAA

Figure 4. Pitman Arm.

CONDITION/INDICATION

IS PITMAN ARM IN GOOD OPERATING CONDITION?

DECISION

YES - Go to Step (5).

NO - Replace pitman arm (Ross) (Volume 3, WP 0496) (Sheppard) (Volume 3, WP 0501). Go to Step (6) to verify problem is solved.

EXCESSIVE PLAY IN STEERING WHEEL - Continued**STEP****5. IS STEERING ASSIST CYLINDER IN GOOD OPERATING CONDITION?**

Check steering assist cylinder for damage and improper adjustment (Volume 3, WP 0510).

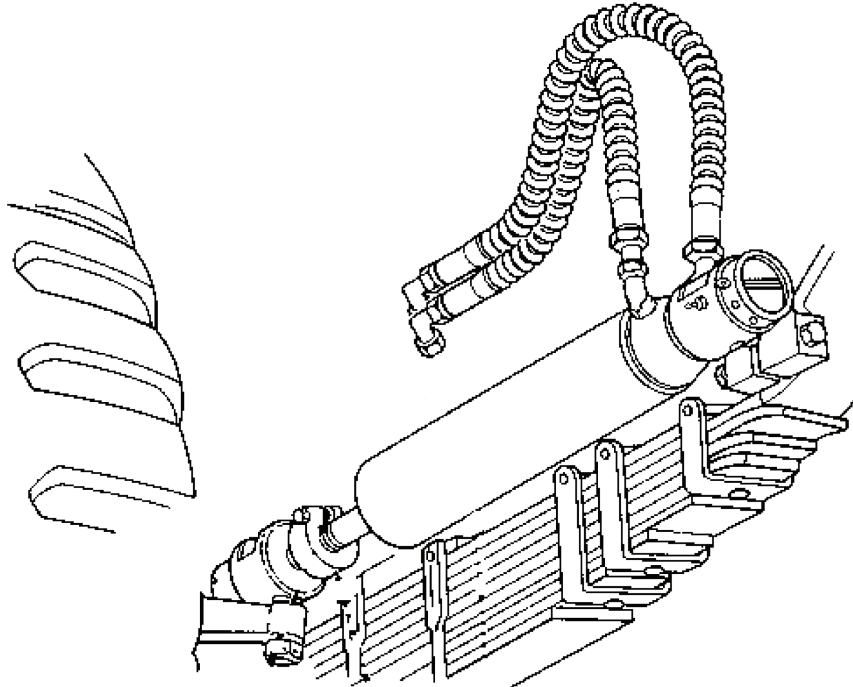

T0558DAA

Figure 5. Steering Assist Cylinder.

CONDITION/INDICATION

IS STEERING ASSIST CYLINDER IN GOOD OPERATING CONDITION?

DECISION

YES - Go to Step (6) to verify problem is solved.

NO - Adjust or replace steering assist cylinder (Volume 3, WP 0510). Go to Step (6) to verify problem is solved.

EXCESSIVE PLAY IN STEERING WHEEL - Continued**STEP**

6. IS YOUR ORIGINAL STEERING WHEEL PLAY PROBLEM STILL PRESENT?
 - a. Ensure vehicle is returned to normal operating condition.
 - b. Check to see if your original steering wheel play problem still exists.
 - c. With engine running, place stiff wire against dash that's long enough to touch the steering wheel rim.
 - d. Turn steering wheel left then right until there is resistance.
 - e. Mark the points on the steering wheel where the travel ends.
 - f. Measure the distance between these points. Distance should be less than 2 1/2 in. (6.3 cm).

CONDITION/INDICATION

IS YOUR ORIGINAL STEERING WHEEL PLAY PROBLEM STILL PRESENT?

DECISION

YES - Notify supervisor.
NO - Problem fixed.

END OF WORK PACKAGE

**FIELD MAINTENANCE
SHIMMY**

INITIAL SETUP:**Tools and Special Tools**

Tool Kit, General Mechanic's: Automotive
(Volume 5, WP 0826, Table 1, Item 56)
High Boy Jack Stand
(Volume 5, WP 0826, Table 1, Item 24)

Personnel Required

(2)

References

Point to Point Schematics
Volume 3, WP 0479

References (cont.)

Volume 3, WP 0480
Volume 3, WP 0481
Volume 3, WP 0482
Volume 3, WP 0483
Volume 3, WP 0484
Volume 3, WP 0485
Volume 3, WP 0493

Equipment Condition

Vehicle parked and engine shut down.
(TM 9-2320-272-10)

TROUBLESHOOTING PROCEDURE**SHIMMY****NOTE**

Conduct these malfunction tests if shimmy is detected. This procedure will check for loose or missing wheel lug nuts, damaged or bent wheels, improper wheel bearing adjustment, front wheel alignment, and loose front axle steering knuckles.

SHIMMY - Continued**STEP****1. ARE THERE ANY LOOSE OR MISSING WHEEL LUG NUTS?**

Visually check front and rear wheels for any loose or missing wheel lug nuts.

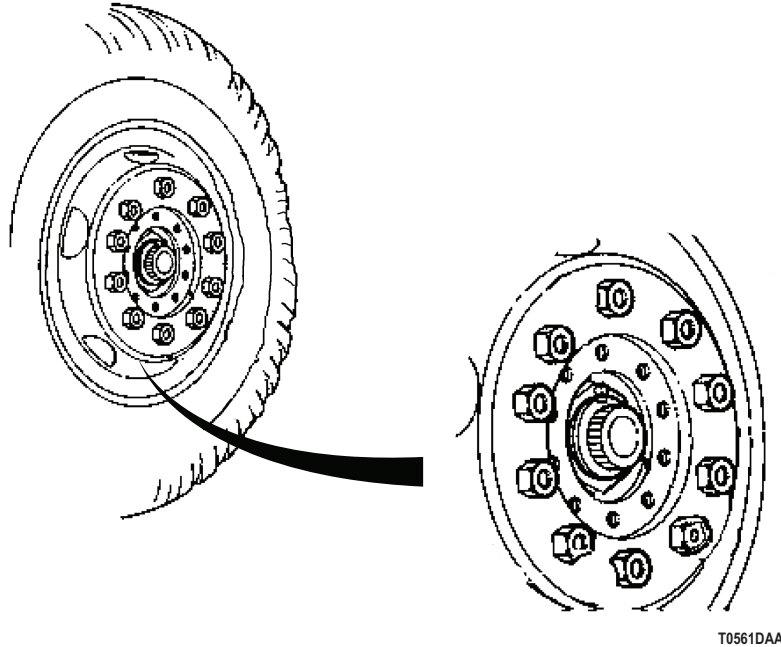

Figure 1. Wheel Lugnuts.

CONDITION/INDICATION

ARE THERE ANY LOOSE OR MISSING WHEEL LUG NUTS?

DECISION

YES - Replace or tighten lug nuts M939 (Volume 3, WP 0484), M939A1/A2 (Volume 3, WP 0485). Go to Step (6) to verify problem is solved.

NO - Go to Step (2).

SHIMMY - Continued**STEP****2. ARE VEHICLE WHEELS IN GOOD OPERATING CONDITION?**

Visually inspect wheels for bends and damage.

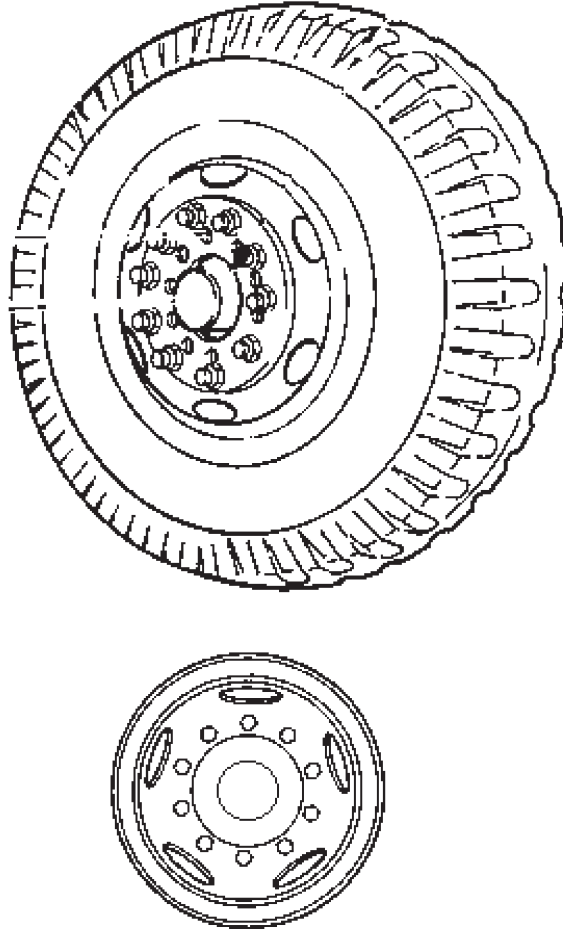

T0560DAA

Figure 2. Wheels.

CONDITION/INDICATION

ARE VEHICLE WHEELS IN GOOD OPERATING CONDITION?

DECISION

YES - Go to Step (3).

NO - Replace bent and damaged wheels M939 (Volume 3, WP 0484), M939A1/A2 (Volume 3, WP 0485). Go to Step (6) to verify problem is solved.

SHIMMY - Continued**STEP**

3. ARE WHEEL BEARINGS IN GOOD OPERATING CONDITION?
 - a. Visually check front and rear wheels bearings for adjustment and damage.

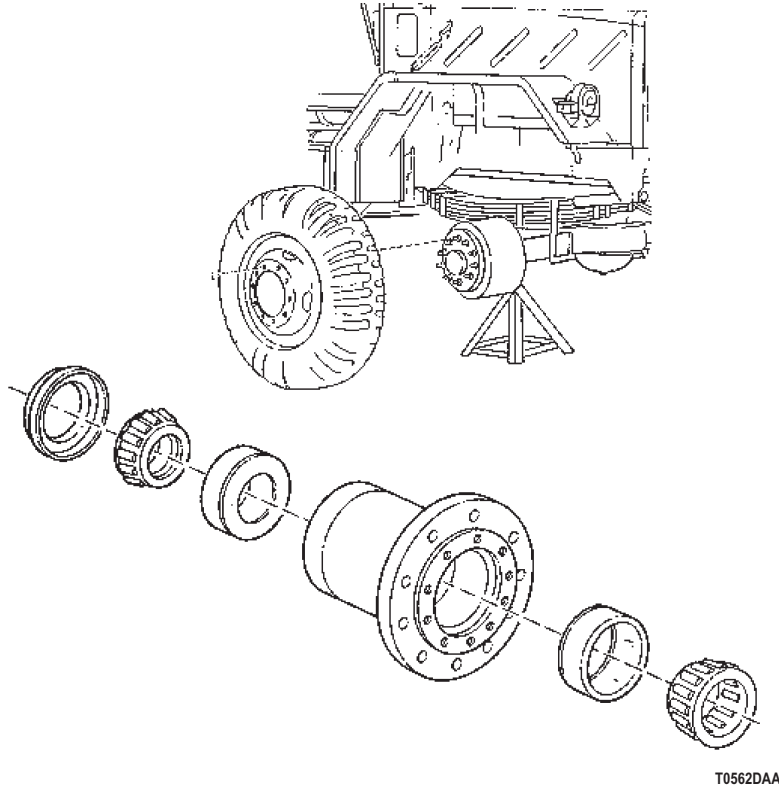

Figure 3. Wheel Bearing Assembly.

- b. Raise vehicle wheels until they are off the ground M939 (Volume 3, WP 0484), M939A1/A2 (Volume 3, WP 0485).

NOTE

Excessive play indicates improperly adjusted or damaged bearings.

- c. Lift up on bottom of tire using a prybar to determine bearing play.

CONDITION/INDICATION

ARE WHEEL BEARINGS IN GOOD OPERATING CONDITION?

DECISION

NO - Moderate play, adjustment required. Adjust wheel bearing(s) (Volume 3, WP 0483).
 NO - Excessive play, front wheel bearing damaged. Replace damaged wheel bearings M939/A1 (Volume 3, WP 0479), M939A2 (Volume 3, WP 0481). Go to Step (6) to verify problem is solved.
 NO - Excessive play, rear wheel bearing damaged. Replace rear wheel bearings M939/A1 (Volume 3, WP 0480), M939A2 (Volume 3, WP 0482). Go to Step (6) to verify problem is solved.
 YES - Go to Step (4).

SHIMMY - Continued**STEP****4. IS FRONT WHEEL ALIGNMENT PROPERLY ADJUSTED?**

Check front wheels for proper alignment setting (toe in check) (Volume 3, WP 0493).

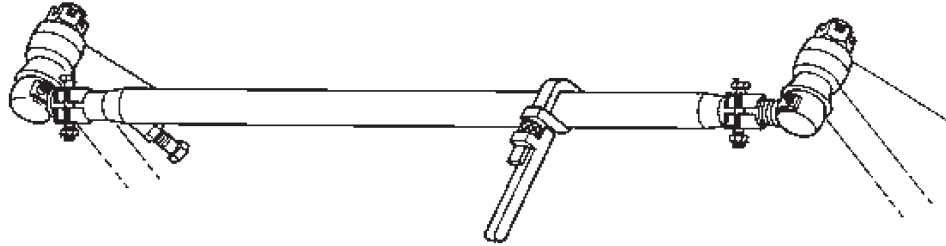

T0548DAA

Figure 4. Toe-In Check.

CONDITION/INDICATION

IS FRONT WHEEL ALIGNMENT PROPERLY ADJUSTED?

DECISION

YES - Go to Step (5).

NO - Adjust front wheel toe-in (Volume 3, WP 0493). Go to Step (6) to verify problem is solved.

SHIMMY - Continued**STEP**

5. ARE FRONT AXLE STEERING KNUCKLES PROPERLY ADJUSTED?
- a. Check front axle steering knuckle(s) for proper adjustment.

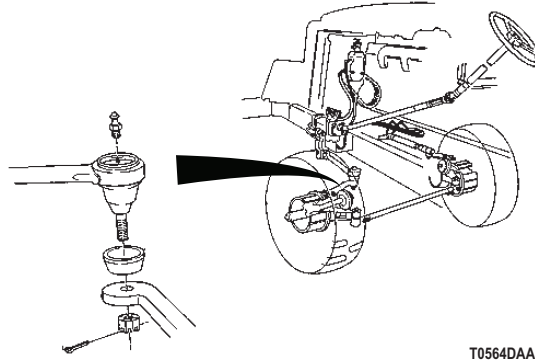

Figure 5. Steering Knuckle.

- b. Raise front vehicle wheels until they are off the ground M939 (Volume 3, WP 0484), M939A1/A2 (Volume 3, WP 0485).
- c. Turn wheels from side to side to check for loose steering knuckle.

CONDITION/INDICATION

ARE FRONT AXLE STEERING KNUCKLES PROPERLY ADJUSTED?

DECISION

YES - Go to Step (6) to verify problem is solved.
 NO - Notify supervisor. Action required may not be possible at this level of maintenance.

STEP

6. IS YOUR ORIGINAL SHIMMY PROBLEM STILL PRESENT?
- a. Ensure vehicle is returned to normal operating condition.
 - b. Check to see if your original shimmy problem still exists.

CONDITION/INDICATION

IS YOUR ORIGINAL SHIMMY PROBLEM STILL PRESENT?

DECISION

YES - Notify supervisor.
 NO - Problem fixed.

END OF WORK PACKAGE

**FIELD MAINTENANCE
CONTINUOUS WANDERING OR SWAYING (POOR CONTROL)**

INITIAL SETUP:**Tools and Special Tools**

Tool Kit, General Mechanic's: Automotive
(Volume 5, WP 0826, Table 1, Item 56)

References (cont.)

Volume 3, WP 0534
Volume 3, WP 0543

Personnel Required

(2)

Equipment Condition

Vehicle parked and engine shut down.
(TM 9-2320-272-10)

References

Point to Point Schematics

TROUBLESHOOTING PROCEDURE**CONTINUOUS WANDERING OR SWAYING (POOR CONTROL)****NOTE**

Conduct these malfunction tests if continuous wandering or swaying is evident. This procedure will check for breaks in front leaf springs, leaking or damaged shock absorbers and loose or damaged spring u-bolts.

CONTINUOUS WANDERING OR SWAYING (POOR CONTROL) - Continued**STEP****1. ARE FRONT LEAF SPRINGS IN GOOD OPERATING CONDITION?**

Visually inspect front leaf springs for breaks.

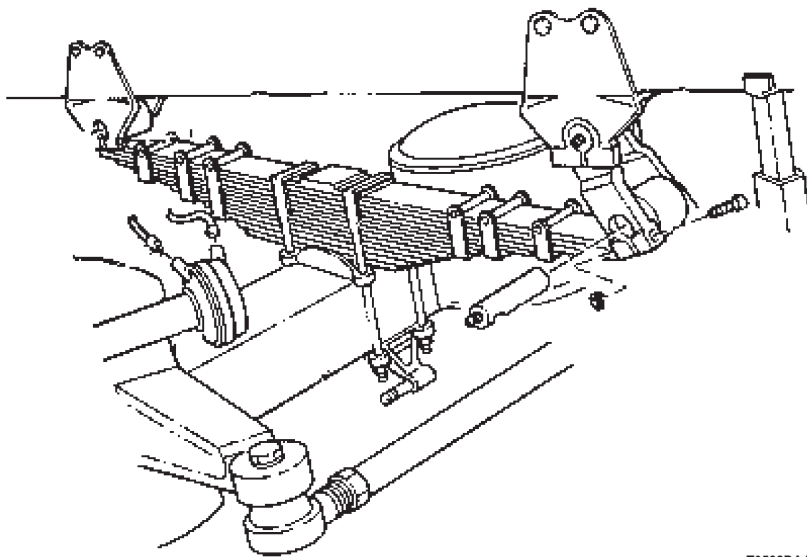

T0582DAA

Figure 1. Leaf Springs.

CONDITION/INDICATION

ARE FRONT LEAF SPRINGS IN GOOD OPERATING CONDITION?

DECISION

YES - Go to Step (2).

NO - Replace broken main leaves (Volume 3, WP 0534). Go to Step (4) to verify problem is solved.

CONTINUOUS WANDERING OR SWAYING (POOR CONTROL) - Continued**STEP****2. ARE SHOCK ABSORBERS IN GOOD OPERATING CONDITION?**

Visually check shock absorbers for leaks and damage.

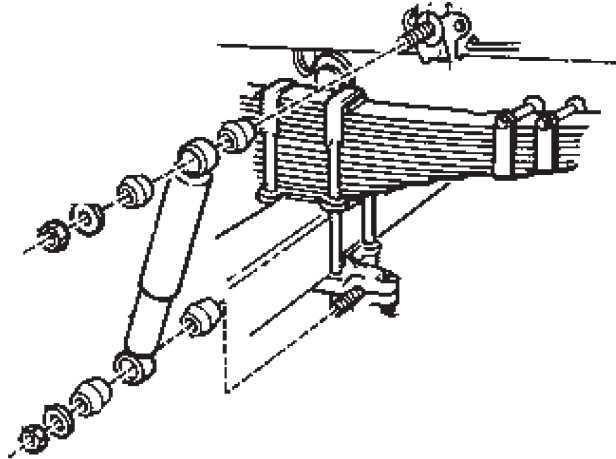

T0583DAA

Figure 2. Shock Absorber.

CONDITION/INDICATION

ARE SHOCK ABSORBERS IN GOOD OPERATING CONDITION?

DECISION

YES - Go to Step (3).

NO - Replace leaking or damaged shock absorbers (Volume 3, WP 0543). Go to Step (4) to verify problem is solved.

CONTINUOUS WANDERING OR SWAYING (POOR CONTROL) - Continued

STEP

3. ARE SPRING U-BOLTS PROPERLY TIGHT AND IN GOOD CONDITION?

Visually check for loose and damaged spring U-bolts.

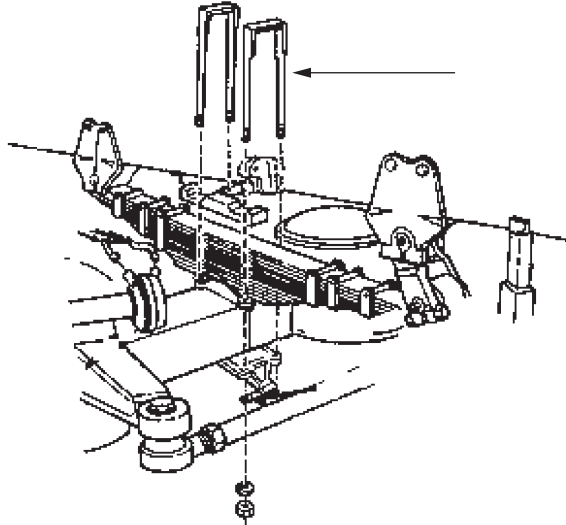

Figure 3. U-Bolts.

CONDITION/INDICATION

ARE SPRING U-BOLTS PROPERLY TIGHT AND IN GOOD CONDITION?

DECISION

YES - Go to Step (4).

NO - Tighten or replace U-bolts as necessary (Volume 3, WP 0534). Go to Step (4) to verify problem is solved.

STEP

4. IS YOUR ORIGINAL VEHICLE CONTROL PROBLEM STILL PRESENT?

- a. Ensure vehicle is returned to normal operating condition.
- b. Check to see if your original vehicle control problem still exists.

CONDITION/INDICATION

IS YOUR ORIGINAL VEHICLE CONTROL PROBLEM STILL PRESENT?

DECISION

YES - Notify supervisor.

NO - Problem fixed.

END OF WORK PACKAGE

**FIELD MAINTENANCE
HARSH OR HARD RIDE**

INITIAL SETUP:**Tools and Special Tools**

Tool Kit, General Mechanic's: Automotive
(Volume 5, WP 0826, Table 1, Item 56)

References (cont.)

Volume 3, WP 0535
Volume 3, WP 0543
Volume 5, WP 0820

Personnel Required

(2)

Equipment Condition

Vehicle parked and engine shut down.
(TM 9-2320-272-10)

References

Point to Point Schematics

TROUBLESHOOTING PROCEDURE**HARSH OR HARD RIDE****NOTE**

Conduct these malfunction tests when a harsh or hard ride is evident. This procedure will check for improper lubrication of springs, pivots and shackle pins, frozen spring shackles and defective shock absorbers.

HARSH OR HARD RIDE - Continued**STEP****1. ARE SPRINGS, PIVOTS, AND SHACKLE PINS PROPERLY LUBRICATED?**

Visually check springs, pivots, and shackle pins for proper lubrication.

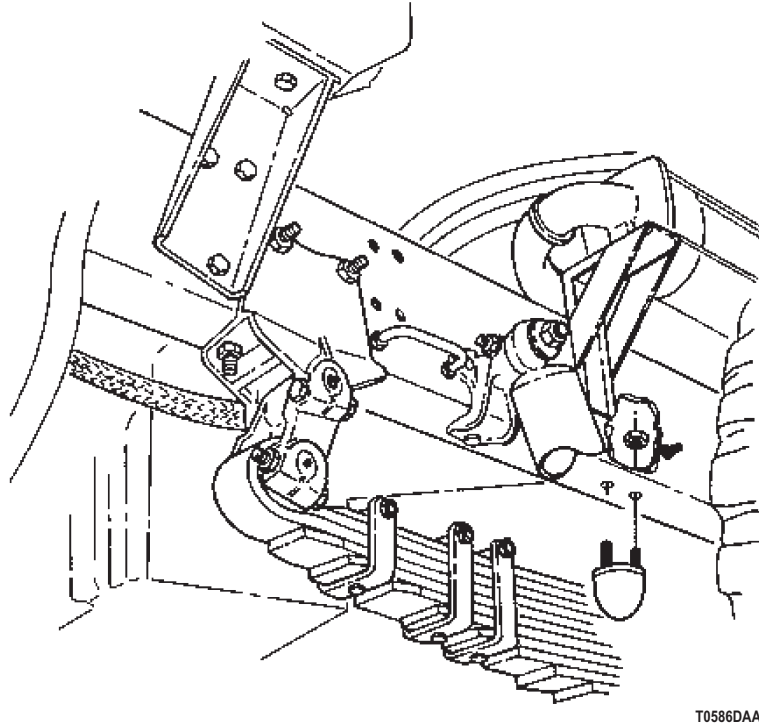

Figure 1. Leaf Springs, Pivots, and Shackle Pins.

CONDITION/INDICATION

ARE SPRINGS, PIVOTS, AND SHACKLE PINS PROPERLY LUBRICATED?

DECISION

YES - Go to Step (2).

NO - Lubricate springs, pivots, and shackle pins (Volume 5, WP 0820). Go to Step (4) to verify problem is solved.

HARSH OR HARD RIDE - Continued**STEP****2. ARE SPRING SHACKLES IN GOOD OPERATING CONDITION?**

Visually check spring shackles for frozen condition.

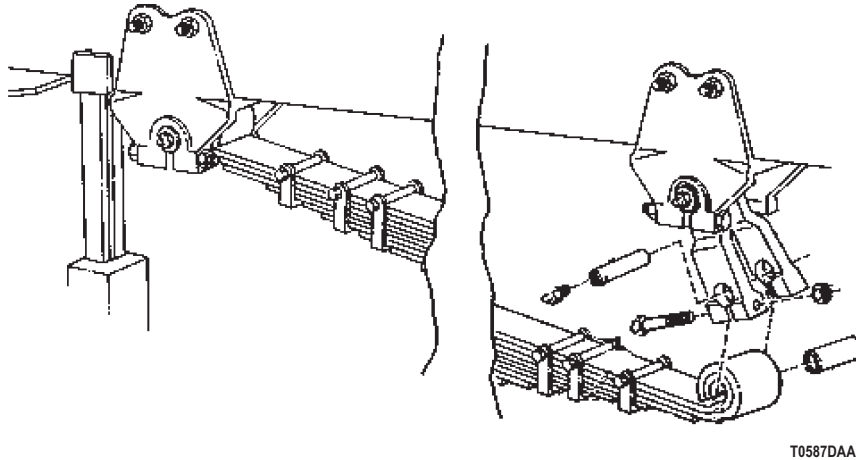

Figure 2. Spring Shackles.

CONDITION/INDICATION

ARE SPRING SHACKLES IN GOOD OPERATING CONDITION?

DECISION

YES - Go to Step (3).

NO - Replace leaf spring shackles (Volume 3, WP 0535). Go to Step (4) to verify problem is solved.

HARSH OR HARD RIDE - Continued**STEP**

3. ARE SHOCK ABSORBERS IN GOOD OPERATING CONDITION?
 - a. Test shock absorbers for resistance.
 - b. Disconnect top end of shock absorber and pull up and down (Volume 3, WP 0543) . If there is little or no resistance, shock absorber is faulty.

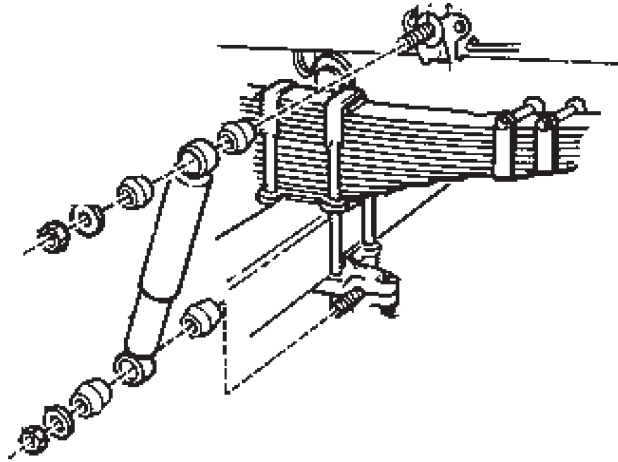

Figure 3. Shock Absorbers.

CONDITION/INDICATION

ARE SHOCK ABSORBERS IN GOOD OPERATING CONDITION?

DECISION

YES - Go to Step (4).

NO - Replace defective shock absorber (Volume 3, WP 0543). Go to Step (4) to verify problem is solved.

STEP

4. IS YOUR ORIGINAL HARSH OR HARD RIDE PROBLEM STILL PRESENT?
 - a. Ensure vehicle is returned to normal operating condition.
 - b. Check to see if your original harsh or hard ride problem still exists.

CONDITION/INDICATION

IS YOUR ORIGINAL HARSH OR HARD RIDE PROBLEM STILL PRESENT?

DECISION

YES - Notify supervisor.

NO - Problem fixed.

END OF WORK PACKAGE

**FIELD MAINTENANCE
SPRING LEAF DEFECT**

INITIAL SETUP:**Tools and Special Tools**

Tool Kit, General Mechanic's: Automotive
(Volume 5, WP 0826, Table 1, Item 56)

References (cont.)

Volume 3, WP 0534
Volume 3, WP 0539

Personnel Required

(2)

Equipment Condition

Vehicle parked and engine shut down.
(TM 9-2320-272-10)

References

Point to Point Schematics

TROUBLESHOOTING PROCEDURE**SPRING LEAF DEFECT****NOTE**

Conduct these malfunction tests if vehicle leans to one side. This procedure will check for loose or damaged front spring shackles, loose or damaged U-bolts and nuts, and spring leaves for breaks.

SPRING LEAF DEFECT - Continued**STEP****1. ARE FRONT SPRING SHACKLES IN GOOD OPERATING CONDITION?**

Visually inspect for loose or damaged front spring shackles.

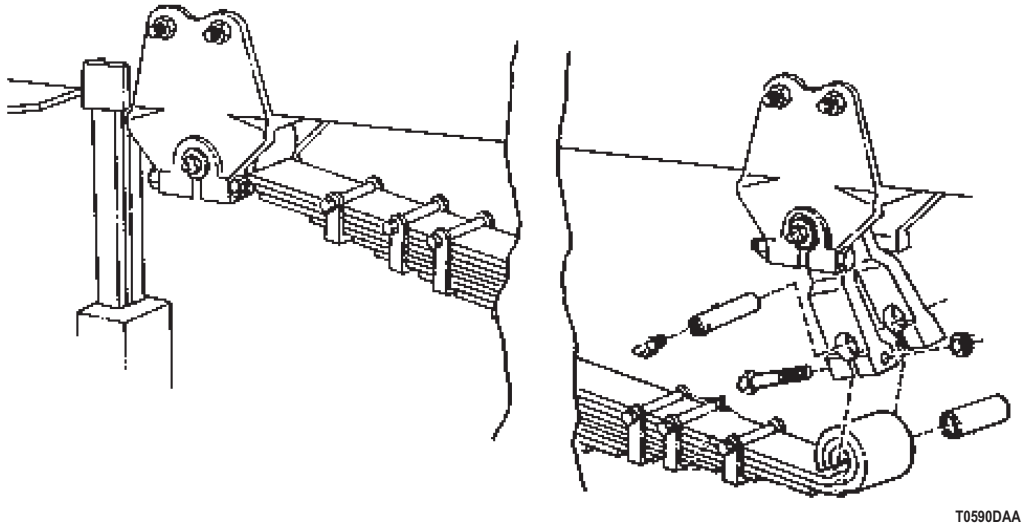

Figure 1. Spring Shackles.

CONDITION/INDICATION

ARE FRONT SPRING SHACKLES IN GOOD OPERATING CONDITION?

DECISION

YES - Go to Step (2).

NO - Tighten or replace as necessary (Volume 3, WP 0535). Go to Step (4) to verify problem is solved.

SPRING LEAF DEFECT - Continued**STEP****2. ARE SPRING U-BOLTS PROPERLY TIGHTENED AND IN GOOD CONDITION?**

Visually check for damaged and loose spring U-bolts and nuts.

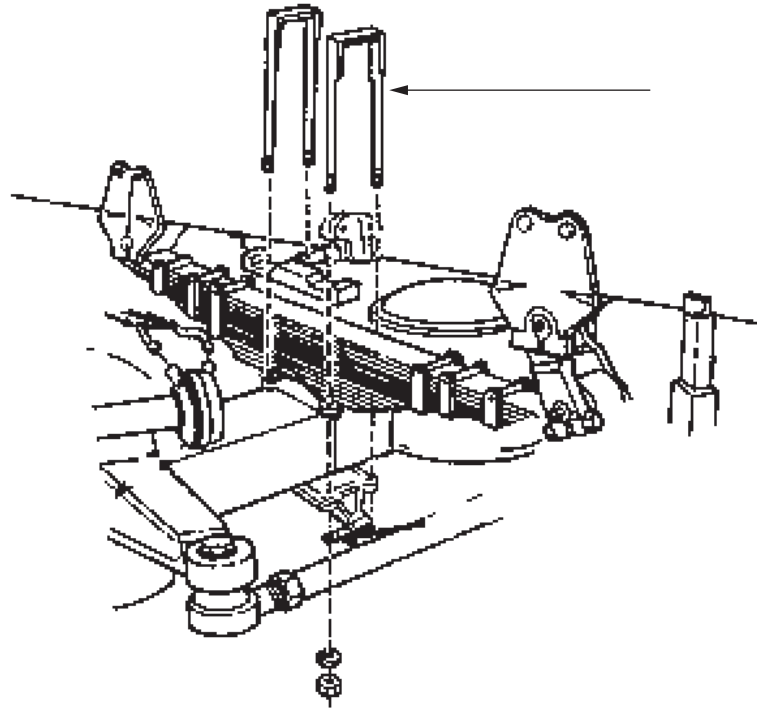

T0591DAA

Figure 2. U-Bolts.

CONDITION/INDICATION

ARE SPRING U-BOLTS PROPERLY TIGHTENED AND IN GOOD CONDITION?

DECISION

YES - Go to Step (3).

NO - Tighten or replace U-bolts as necessary (Volume 3, WP 0534). Go to Step (4) to verify problem is solved.

SPRING LEAF DEFECT - Continued**STEP****3. ARE SPRING LEAVES IN GOOD OPERATING CONDITION?**

Visually inspect front and rear spring leaves for breaks and damage.

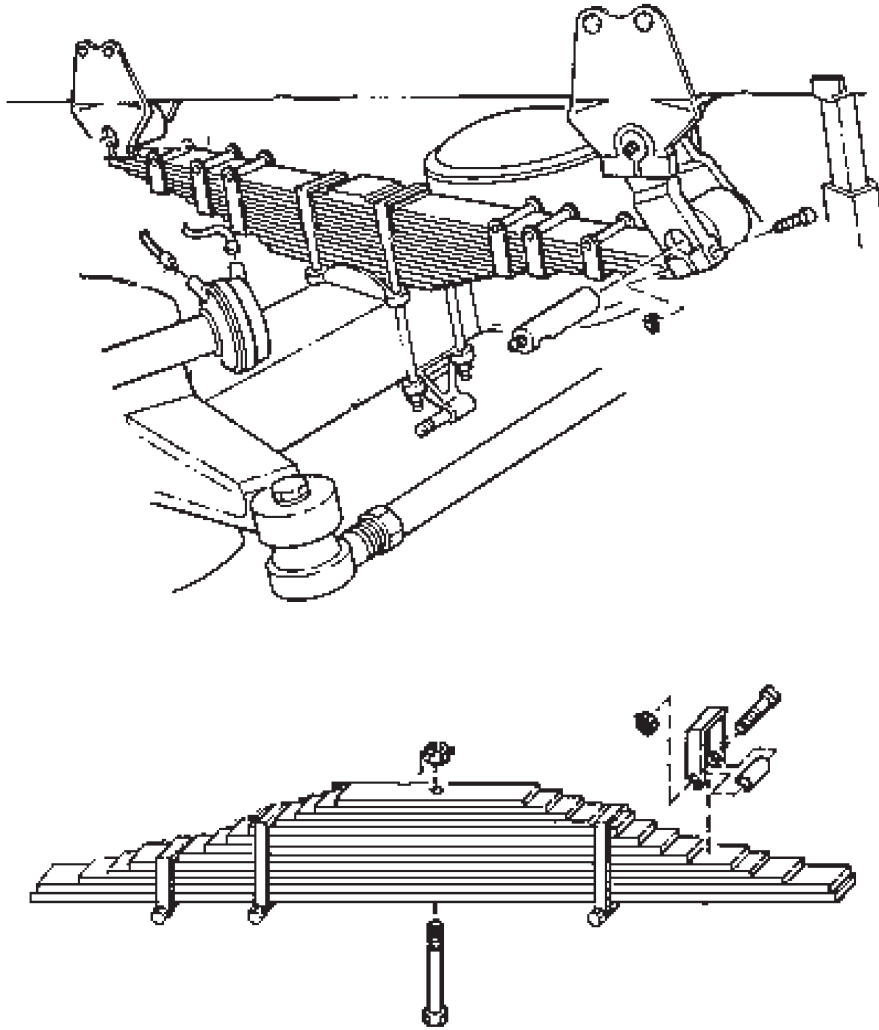

T0592DAA

Figure 3. Leaf Springs and Shackle Pins.

CONDITION/INDICATION

ARE SPRING LEAVES IN GOOD OPERATING CONDITION?

DECISION

YES - Go to Step (4) to verify problem is solved.

NO - Front spring damaged. Replace damaged spring leaves (Volume 3, WP 0534). Go to Step (4) to verify problem is solved.

NO - Rear spring leaves damaged. Replace damaged spring leaves (Volume 3, WP 0539). Go to Step (4) to verify problem is solved.

SPRING LEAF DEFECT - Continued**STEP**

4. IS YOUR ORIGINAL VEHICLE LEANING PROBLEM STILL PRESENT?
 - a. Ensure vehicle is returned to normal operating condition.
 - b. Check to see if your original spring leaf problem still exists.

CONDITION/INDICATION

IS YOUR ORIGINAL VEHICLE LEANING PROBLEM STILL PRESENT?

DECISION

YES - Notify supervisor.
NO - Problem fixed.

END OF WORK PACKAGE

**FIELD MAINTENANCE
WINCH DOES NOT OPERATE**

INITIAL SETUP:**Tools and Special Tools**

Tool Kit, General Mechanic's: Automotive
(Volume 5, WP 0826, Table 1, Item 56)
Test Set, Electronic Systems
(Volume 5, WP 0826, Table 1, Item 51)

Personnel Required

(2)

References

Point to Point Schematics
TM 9-2320-272-10

References (cont.)

Volume 4, WP 0668
Volume 4, WP 0683
Volume 4, WP 0694
Volume 4, WP 0704
Volume 4, WP 0707
Volume 5, WP 0820

Equipment Condition

Vehicle parked and engine shut down.
(TM 9-2320-272-10)

TROUBLESHOOTING PROCEDURE**WINCH DOES NOT OPERATE****NOTE**

Conduct these malfunction tests if front winch does not operate. This procedure will check for proper oil level, power takeoff linkage for breaks and adjustment, drum clutch engaged, drum lock pulled out, damaged winch control cable, oil lines for damage and leaks, return line oil filter for leaks, hydraulic oil tank filter, oil pump for leaks and overheating, and winch motor for leaks.

WINCH DOES NOT OPERATE - Continued**STEP****1. IS HYDRAULIC OIL LEVEL AT PROPER LEVEL?**

Check reservoir for proper oil level (Volume 5, WP 0820).

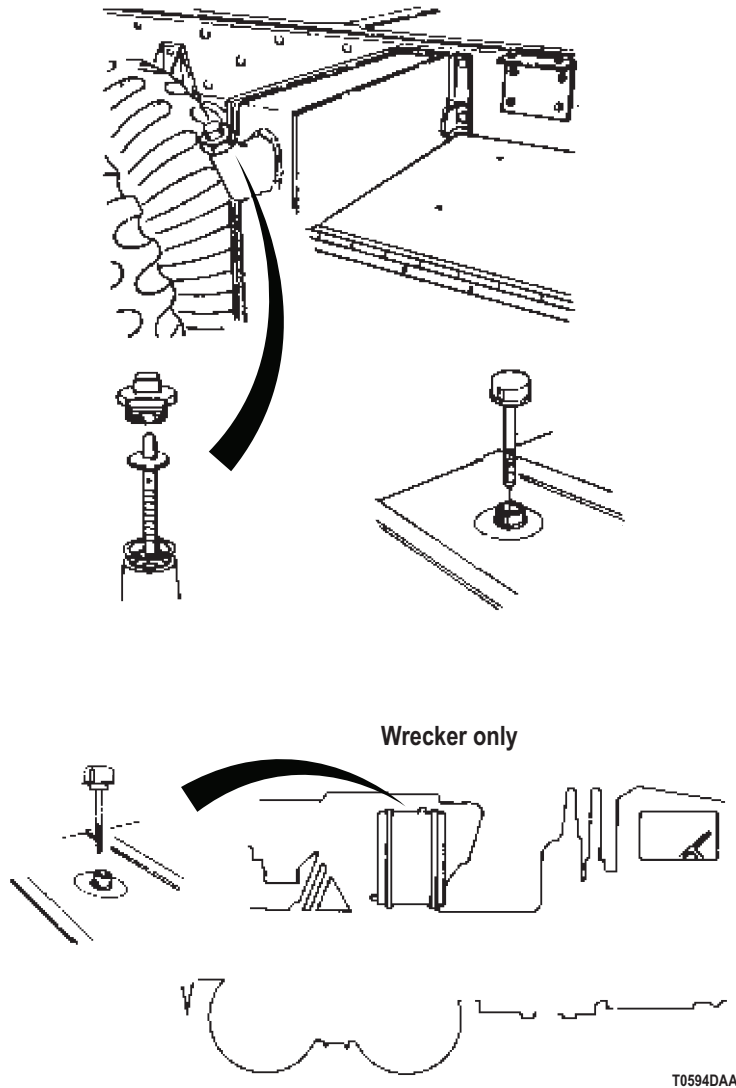

Figure 1. Hydraulic Oil Check.

CONDITION/INDICATION

IS HYDRAULIC OIL LEVEL AT PROPER LEVEL?

DECISION

YES - Go to Step (2).

NO - Fill to proper level (Volume 5, WP 0820). Go to Step (12) to verify problem is solved.

WINCH DOES NOT OPERATE - Continued**STEP****2. DOES POWER TAKEOFF ENGAGE?**

Engage power takeoff (TM 9-2320-272-10).

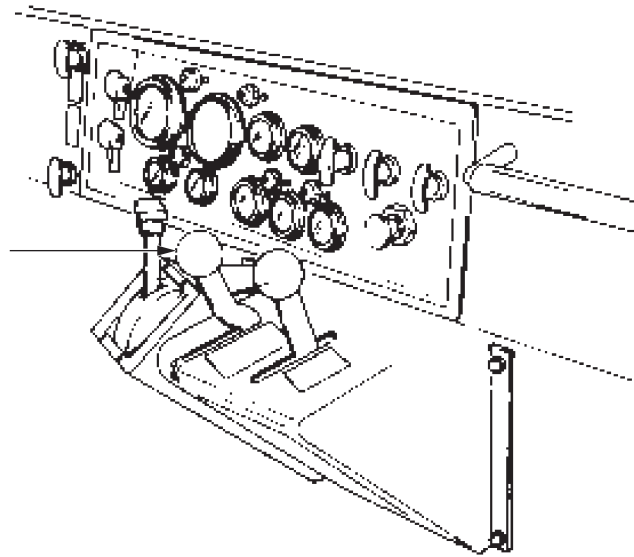

T0595DAA

Figure 2. Power Takeoff Controls.

CONDITION/INDICATION

DOES POWER TAKEOFF ENGAGE?

DECISION

YES - Go to Step (3).

NO - Notify supervisor. Action may not be possible at this level of maintenance.

WINCH DOES NOT OPERATE - Continued**STEP****3. IS POWER TAKEOFF LINKAGE IN GOOD OPERATING CONDITION?**

Visually inspect power takeoff linkage for breaks and proper adjustment.

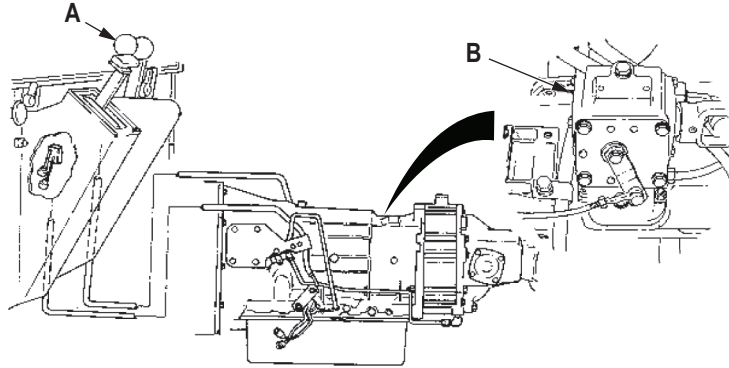

A POWER TAKEOFF CONTROL LEVER

B TRANSMISSION POWER TAKEOFF

T0867DAA

Figure 3. Power Takeoff Linkage.

CONDITION/INDICATION

IS POWER TAKEOFF LINKAGE IN GOOD OPERATING CONDITION?

DECISION

YES - Go to Step (4).

NO - Notify supervisor. Action may not be possible at this level of maintenance.

WINCH DOES NOT OPERATE - Continued**STEP**

4. DOES FRONT DRUM CLUTCH ENGAGE (FRONT WINCH)?
 - a. Engage front drum clutch (TM 9-2320-272-10).

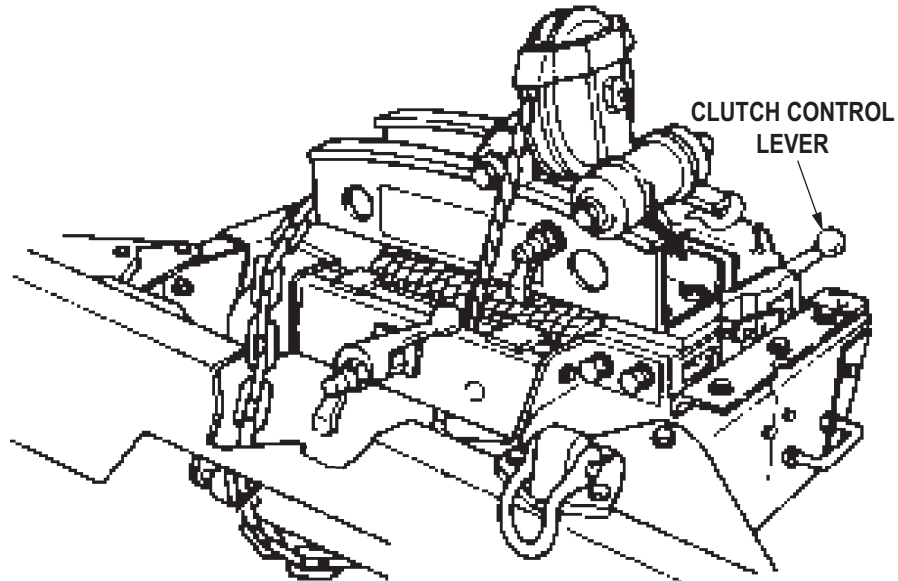

T0596DAA

Figure 4. Front Winch.

- b. Check if front drum clutch is engaged.

CONDITION/INDICATION

DOES FRONT DRUM CLUTCH ENGAGE (FRONT WINCH)?

DECISION

YES - Go to Step (5).

NO - Replace front winch (Volume 4, WP 0668). Go to Step (12) to verify problem is solved.

WINCH DOES NOT OPERATE - Continued**STEP****5. DOES DRUM LOCK PULL OUT?**

Pull out drum lock (TM 9-2320-272-10).

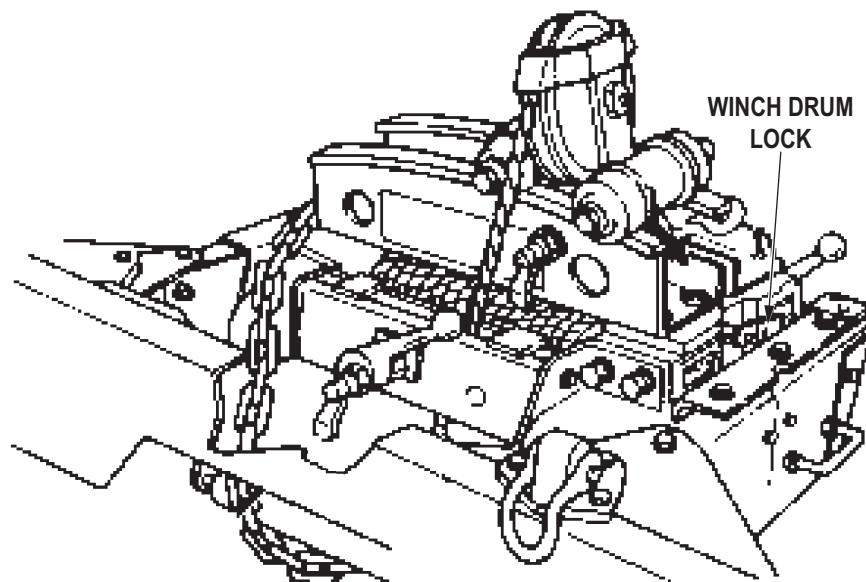

T0597DAA

Figure 5. Front Winch Drum Lock.

CONDITION/INDICATION

DOES DRUM LOCK PULL OUT?

DECISION

YES - Go to Step (6).

NO - Replace front winch (Volume 4, WP 0668). Go to Step (12) to verify problem is solved.

WINCH DOES NOT OPERATE - Continued**STEP**

6. IS WINCH CONTROL CABLE IN GOOD OPERATING CONDITION?
 - a. Locate winch control cable.
 - b. Visually check winch control cable for damage.

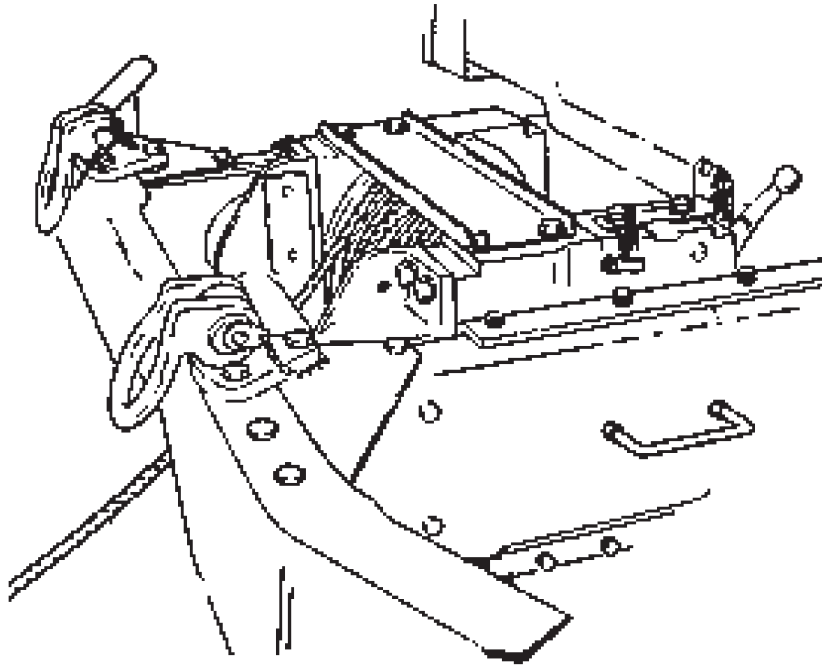

T0598DAA

Figure 6. Front Winch.

CONDITION/INDICATION

IS WINCH CONTROL CABLE IN GOOD OPERATING CONDITION?

DECISION

YES - Go to Step (7).

NO - Notify supervisor. Action may not be possible at this level of maintenance.

WINCH DOES NOT OPERATE - Continued**STEP****7. ARE ALL OIL LINES IN GOOD OPERATING CONDITION?**

- a. Determine operating condition of all oil lines. Refer to point to point schematics.

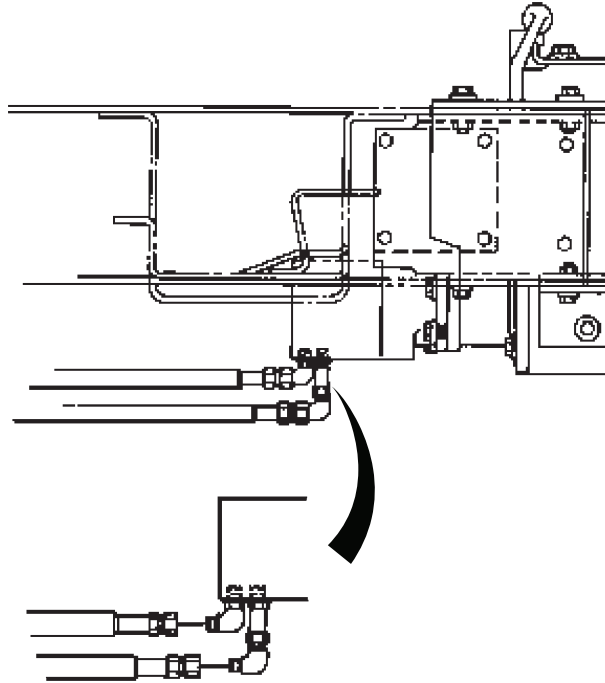

T0599DAA

Figure 7. Oil Lines.

- b. Visually check all oil lines for damage and leaks. Refer to point to point schematics.

CONDITION/INDICATION

ARE ALL OIL LINES IN GOOD OPERATING CONDITION?

DECISION

YES - Go to Step (8).

NO - Replace damaged hoses (Volume 4, WP 0685).

WINCH DOES NOT OPERATE - Continued**STEP**

8. IS RETURN LINE OIL FILTER IN GOOD CONDITION?
 - a. Locate oil return line filter housing. Refer to point to point schematics.
 - b. Visually inspect oil return line filter housing for leaks.

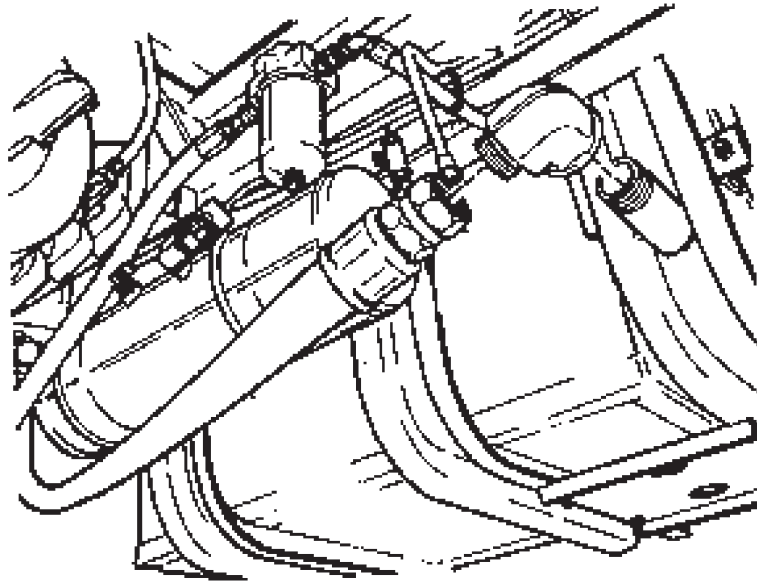

T0600DAA

Figure 8. Oil Return Line.

CONDITION/INDICATION

IS RETURN LINE OIL FILTER IN GOOD CONDITION?

DECISION

YES - Go to Step (9).

NO - Tighten filter housing nut (Volume 4, WP 0704). Go to Step (12) to verify problem is solved.

WINCH DOES NOT OPERATE - Continued**STEP****9. IS HYDRAULIC OIL TANK FILTER IN GOOD CONDITION?****NOTE**

If BYPASS is indicated, filter is faulty.

Locate and visually inspect oil filter.

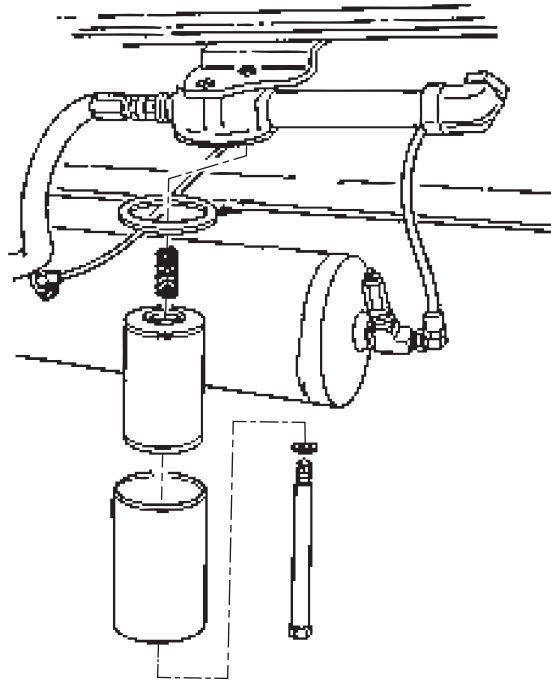

T0601DAA

Figure 9. Oil Filter.

CONDITION/INDICATION

IS HYDRAULIC OIL TANK FILTER IN GOOD CONDITION?

DECISION

YES - Go to Step (10).

NO - Replace filter (Volume 4, WP 0704). Go to Step (12) to verify problem is solved.

WINCH DOES NOT OPERATE - Continued**STEP**

10. IS OIL PUMP IN GOOD OPERATING CONDITION?
- Visually check oil pump for leaks and overheating.

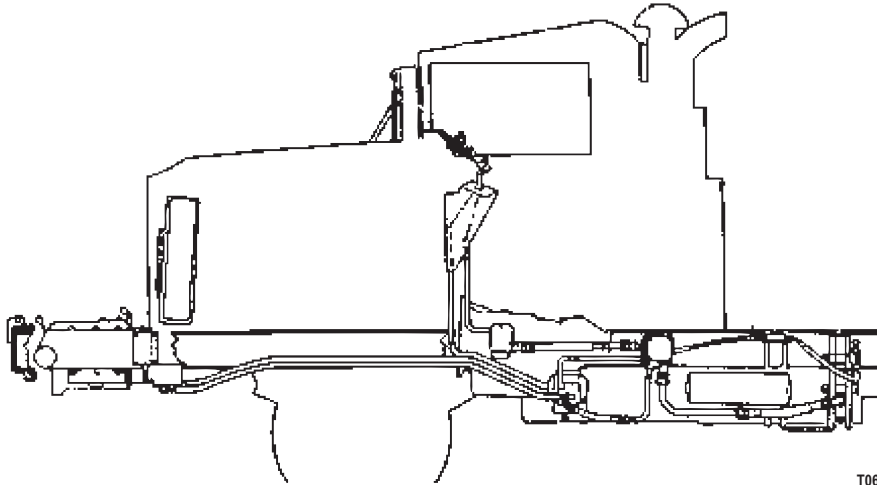

T0602DAA

Figure 10. Oil Pump.

NOTE

If leaks continue or overheating is detected, oil pump is faulty.

- Tighten loose fittings.

CONDITION/INDICATION

IS OIL PUMP IN GOOD OPERATING CONDITION?

DECISION

YES - Go to Step (11).

NO - Replace oil pump (Volume 4, WP 0683). Go to Step (12) to verify problem is solved.

WINCH DOES NOT OPERATE - Continued**STEP****11. IS WINCH MOTOR IN GOOD OPERATING CONDITION?**

Visually check winch motor for leaks.

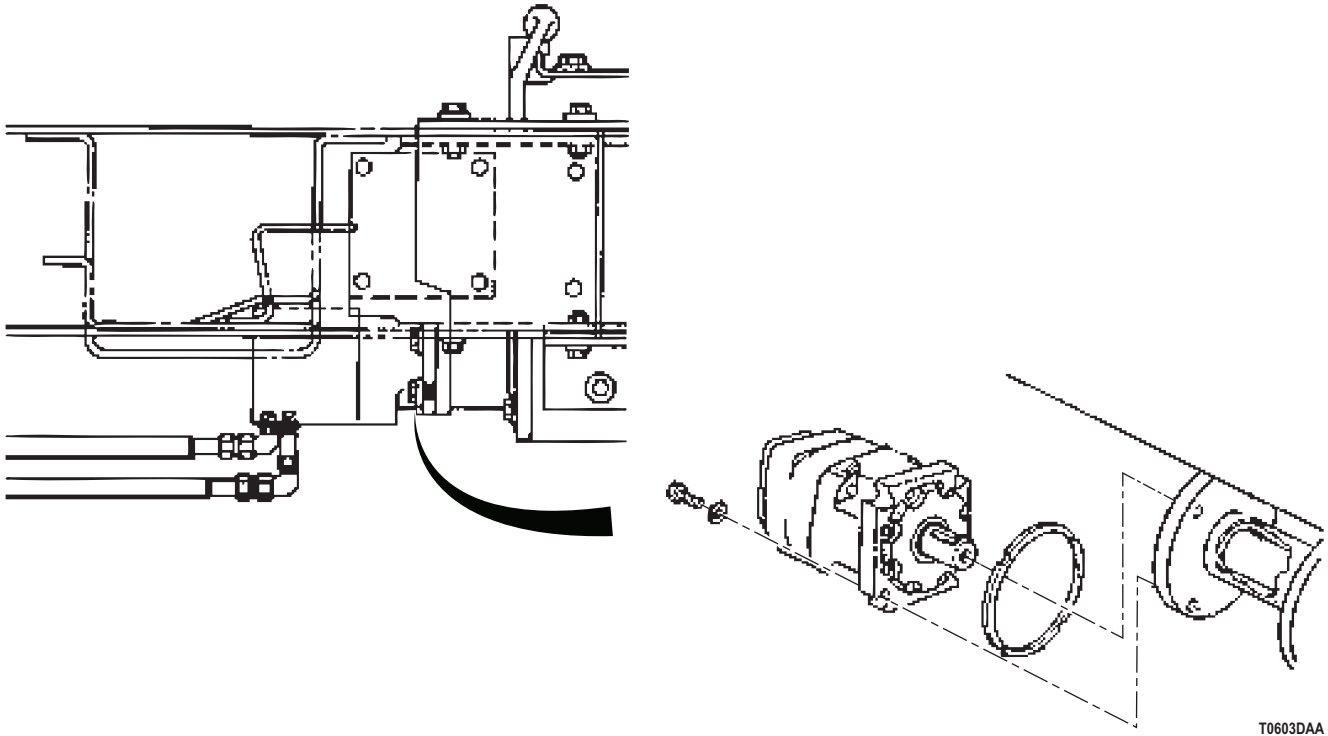

Figure 11. Winch Motor.

CONDITION/INDICATION

IS WINCH MOTOR IN GOOD OPERATING CONDITION?

DECISION

YES - Go to Step (12) to verify problem is solved.

NO - Replace winch motor (Volume 4, WP 0694). Go to Step (12) to verify problem is solved.

WINCH DOES NOT OPERATE - Continued**STEP**

12. IS YOUR ORIGINAL WINCH PROBLEM STILL PRESENT?
- a. Ensure vehicle is returned to normal operating condition.
 - b. Check to see if your original winch problem still exists.

CONDITION/INDICATION

IS YOUR ORIGINAL WINCH PROBLEM STILL PRESENT?

DECISION

YES - Notify supervisor.
NO - Problem fixed.

END OF WORK PACKAGE

**FIELD MAINTENANCE
WINCH OPERATES IN ONE DIRECTION ONLY**

INITIAL SETUP:**Tools and Special Tools**

Tool Kit, General Mechanic's: Automotive
(Volume 5, WP 0826, Table 1, Item 56)
Test Set, Electronic Systems
(Volume 5, WP 0826, Table 1, Item 51)

References (cont.)

TM 9-2320-272-10
Volume 4, WP 0677
Volume 4, WP 0680
Volume 4, WP 0681

Personnel Required

(2)

Equipment Condition

Vehicle parked and engine shut down.
(TM 9-2320-272-10)

References

Point to Point Schematics

TROUBLESHOOTING PROCEDURE**WINCH OPERATES IN ONE DIRECTION ONLY****NOTE**

Conduct these malfunction tests if winch operates in one direction only. This procedure will check for damage to the winch control cable (front winch), in and out movement of winch check valve, damaged or leaking control valve, rear winch tensioner released and rear winch control lever engaged.

WINCH OPERATES IN ONE DIRECTION ONLY - Continued**STEP**

1. IS WINCH CONTROL CABLE IN GOOD OPERATING CONDITION?
 - a. Locate winch control cable.
 - b. Visually inspect winch control cable for signs of damage.

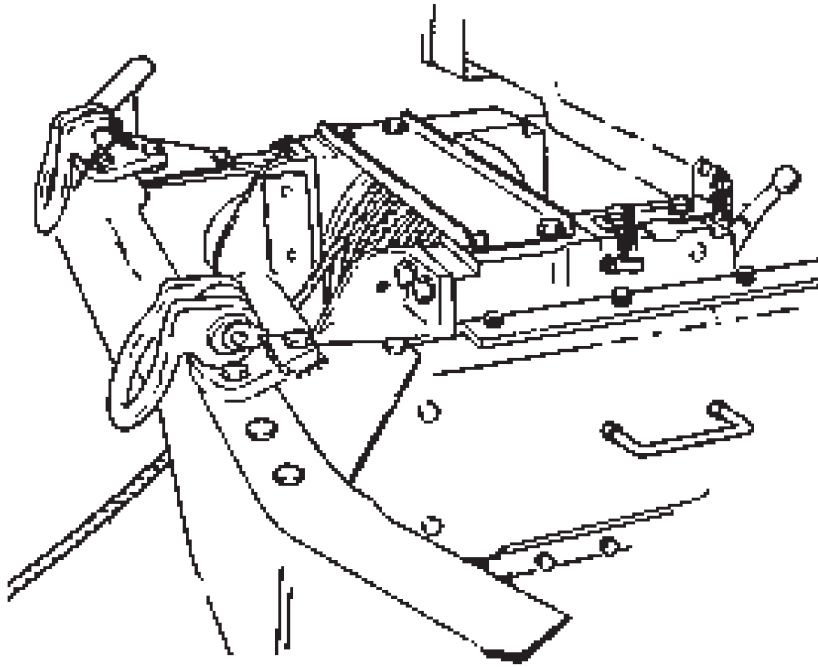

T1047DAA

Figure 1. Front Winch.

CONDITION/INDICATION

IS WINCH CONTROL CABLE IN GOOD OPERATING CONDITION?

DECISION

- YES - Go to Step (2).
NO - Replace control cable (Volume 4, WP 0680).

WINCH OPERATES IN ONE DIRECTION ONLY - Continued**STEP**

2. IS VALVE SHAFT MOVING IN AND OUT?
 - a. Visually check for in and out valve shaft movement.
 - b. Check control valve for damage.

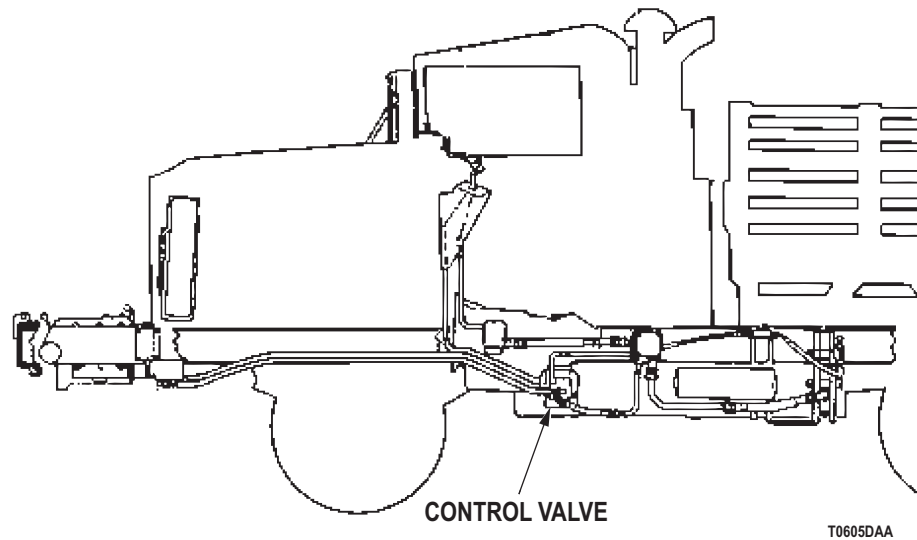

Figure 2. Control Valve.

CONDITION/INDICATION

IS VALVE SHAFT MOVING IN AND OUT?

DECISION

YES - M936 vehicles, go to Step (3). All other vehicles, go to Step (5) to verify problem is solved.
NO - Replace control valve (Volume 4, WP 0681).

WINCH OPERATES IN ONE DIRECTION ONLY - Continued**STEP**

3. DOES AIR OPERATED TENSIONER RELEASE?
 - a. Visually inspect if air operated tensioner is released.

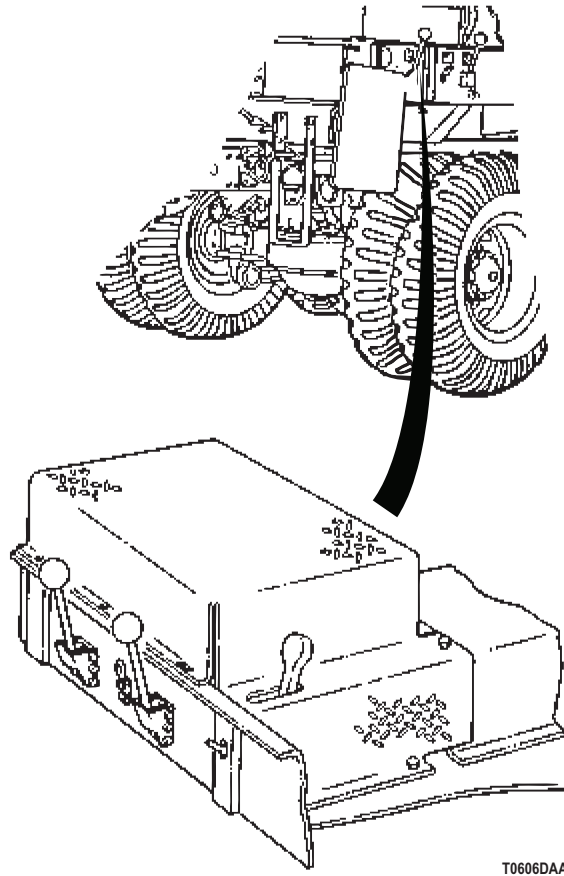

Figure 3. Air Operator Tensioner.

- b. Release tensioner (TM 9-2320-272-10).

CONDITION/INDICATION

DOES AIR OPERATED TENSIONER RELEASE?

DECISION

- YES - Go to Step (4).
NO - Repair cable tensioner (Volume 4, WP 0677).

WINCH OPERATES IN ONE DIRECTION ONLY - Continued**STEP****4. DOES WINCH TORQUE CONTROL LEVER REMAIN ENGAGED?**

Attempt to engage winch torque control lever (TM 9-2320-272-10).

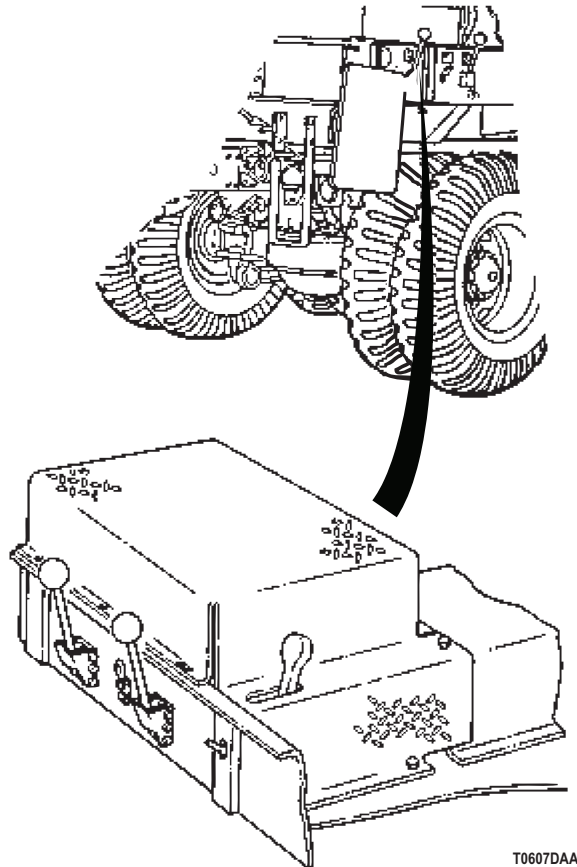

Figure 4. Winch Torque Control Lever.

CONDITION/INDICATION

DOES WINCH TORQUE CONTROL LEVER REMAIN ENGAGED?

DECISION

YES - Go to Step (5) to verify problem is solved.
NO - Repair cable tensioner (Volume 4, WP 0677).

WINCH OPERATES IN ONE DIRECTION ONLY - Continued**STEP**

5. IS YOUR ORIGINAL WINCH PROBLEM STILL PRESENT?
 - a. Ensure vehicle is returned to normal operating condition.
 - b. Check to see if your original winch problem still exists.

CONDITION/INDICATION

IS YOUR ORIGINAL WINCH PROBLEM STILL PRESENT?

DECISION

YES - Notify supervisor.
NO - Problem fixed.

END OF WORK PACKAGE

**FIELD MAINTENANCE
DRAG BRAKE DOES NOT OPERATE**

INITIAL SETUP:**Tools and Special Tools**

Tool Kit, General Mechanic's: Automotive
(Volume 5, WP 0826, Table 1, Item 56)

References (cont.)

Volume 4, WP 0668
Volume 4, WP 0672
Volume 4, WP 0673

Personnel Required

(2)

Equipment Condition

Vehicle parked and engine shut down.
(TM 9-2320-272-10)

References

Point to Point Schematics

TROUBLESHOOTING PROCEDURE**DRAG BRAKE DOES NOT OPERATE****NOTE**

- Conduct these malfunction tests if winch drag brake does not operate. This procedure will check for drag brake adjustment.
- M939 series vehicles utilize two types of winches depending on configuration, one type of winch uses level wind drag brake whereas the other does not. Ensure to determine the type prior to troubleshooting.

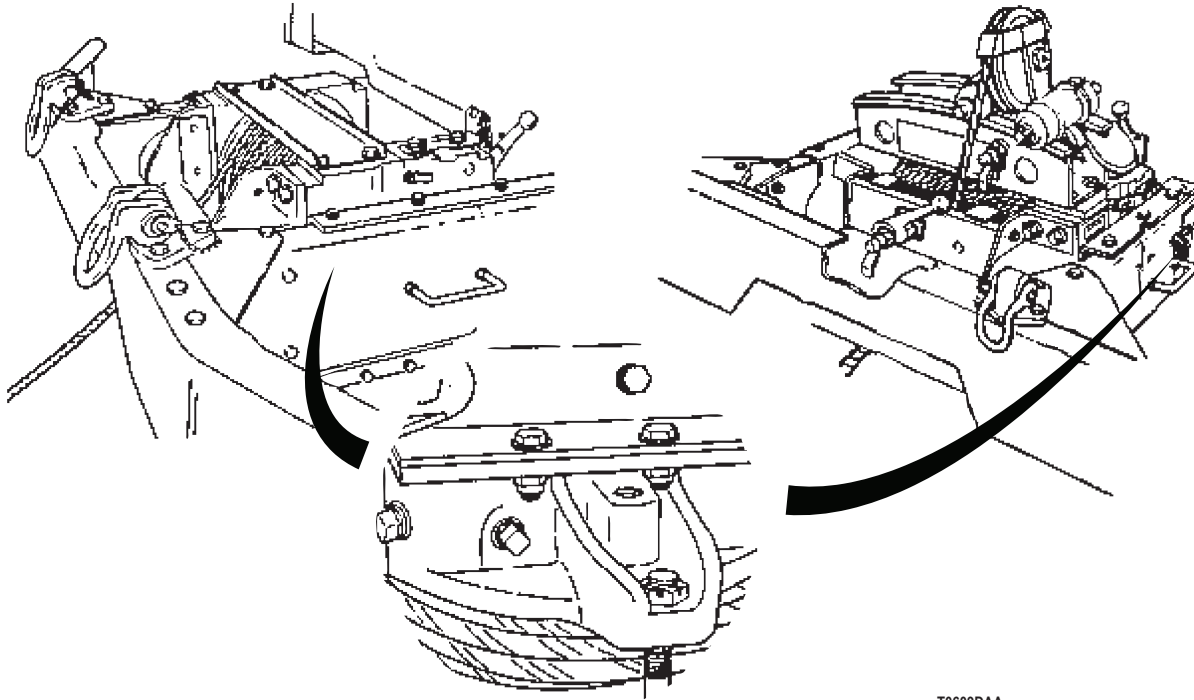
DRAG BRAKE DOES NOT OPERATE - Continued**STEP****1. IS THE DRAG BRAKE PROPERLY ADJUSTED?**

T0609DAA

Figure 1. Front Winch.

- a. Inspect automatic winch drag brake adjustment (Volume 4, WP 0672) on front winch.
- b. Inspect winch drag brake adjustment (Volume 4, WP 0673) on front and rear winch.

CONDITION/INDICATION

IS THE DRAG BRAKE PROPERLY ADJUSTED?

DECISION

- NO - Automatic drag brake adjustment faulty. Adjust drag brake (Volume 4, WP 0672). Go to Step (2).
 NO - Drag brake adjustment faulty. Adjust drag brake (Volume 4, WP 0673). Go to Step (2).
 YES - Go to Step (3) to verify problem is solved.

DRAG BRAKE DOES NOT OPERATE - Continued**STEP**

2. WAS DRAG BRAKE SUCCESSFULLY ADJUSTED?

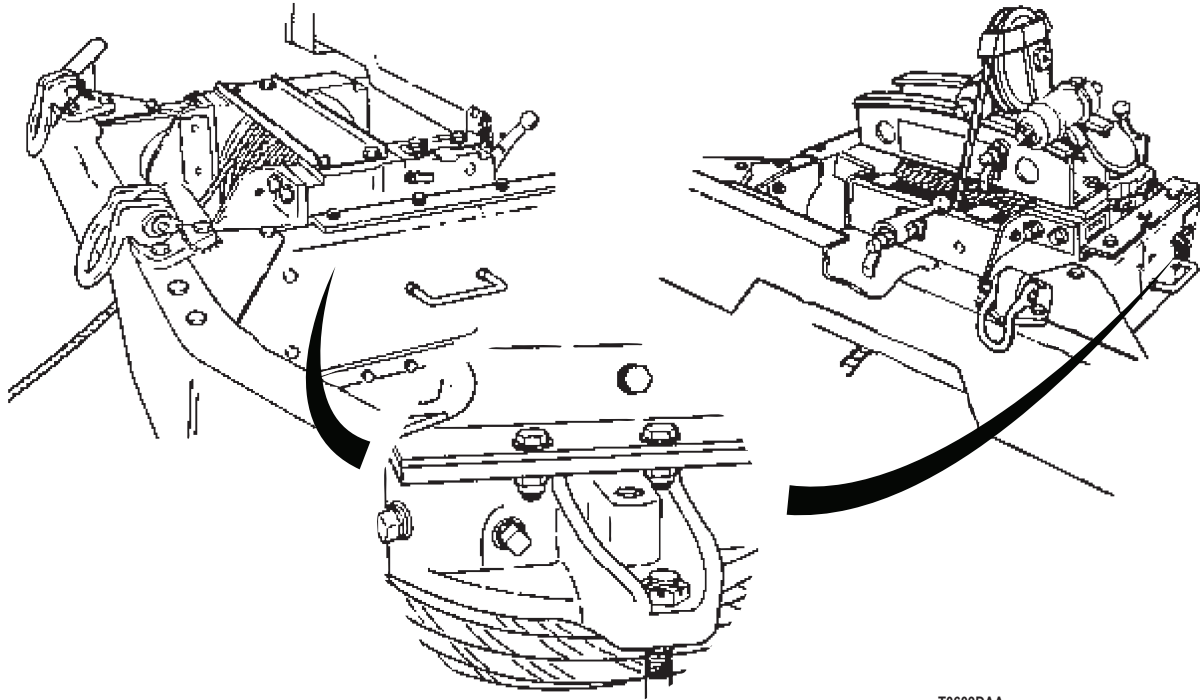

T0609DAA

Figure 2. Front Winch.

NOTE

If drag brake could not be adjusted, winch must be replaced.

- a. Inspect automatic winch drag brake adjustment (Volume 4, WP 0672) on front winch.
- b. Inspect winch drag brake adjustment (Volume 4, WP 0673) on front and rear winch.

CONDITION/INDICATION

WAS DRAG BRAKE SUCCESSFULLY ADJUSTED?

DECISION

YES - Go to Step (3) to verify problem is solved.

NO - Front winch drag brake could not be adjusted. Replace front winch (Volume 4, WP 0668). Go to Step (3) to verify problem is solved.

DRAG BRAKE DOES NOT OPERATE - Continued**STEP**

3. IS YOUR ORIGINAL WINCH PROBLEM STILL PRESENT?
 - a. Ensure vehicle is returned to normal operating condition.
 - b. Check to see if your original winch problem still exists.

CONDITION/INDICATION

IS YOUR ORIGINAL WINCH PROBLEM STILL PRESENT?

DECISION

YES - Notify supervisor.
NO - Problem fixed.

END OF WORK PACKAGE

**FIELD MAINTENANCE
WINCH WILL NOT HOLD LOAD**

INITIAL SETUP:**Tools and Special Tools**

Tool Kit, General Mechanic's: Automotive
(Volume 5, WP 0826, Table 1, Item 56)

Personnel Required

(2)

References

Point to Point Schematics
Volume 4, WP 0668

References (cont.)

Volume 4, WP 0669
Volume 4, WP 0672
Volume 4, WP 0673
Volume 4, WP 0722

Equipment Condition

Vehicle parked and engine shut down.
(TM 9-2320-272-10)

TROUBLESHOOTING PROCEDURE**WINCH WILL NOT HOLD LOAD****NOTE**

Conduct these malfunction tests if the winch will not hold a load. This procedure will check for an improperly set torque control lever and if the automatic brake needs adjustment.

WINCH WILL NOT HOLD LOAD - Continued**STEP**

1. CAN TORQUE CONTROL LEVER BE SET TO HIGH OR LOW POSITION?
 - a. Visually check torque control lever position.
 - b. If level is not positioned in HIGH or LOW, reposition lever to HIGH or LOW.

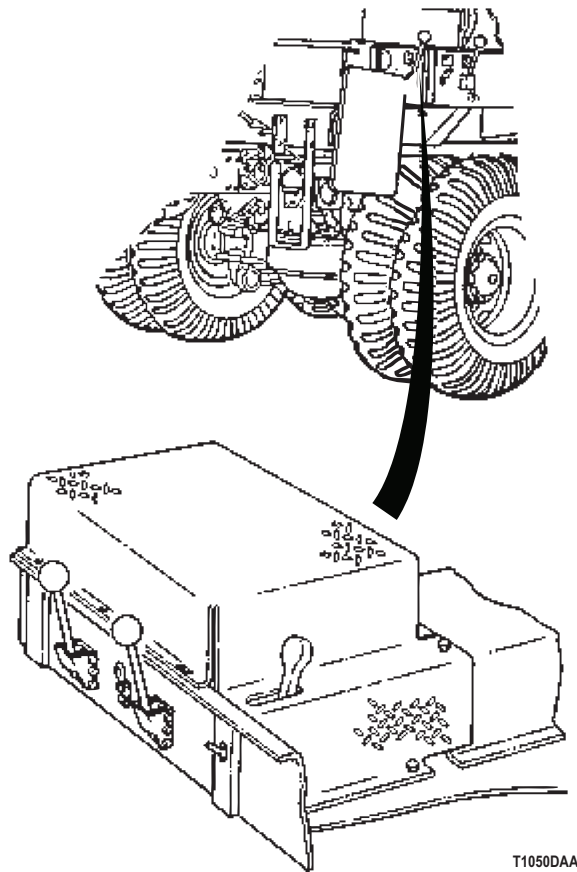

Figure 1. Torque Control Lever.

CONDITION/INDICATION

CAN TORQUE CONTROL LEVER BE SET TO HIGH OR LOW POSITION?

DECISION

- YES - Go to Step (2).
 NO - Repair cable tensioner (Volume 4, WP 0677).

STEP

2. CAN BRAKE SETSCREW AND WINCH CABLE TENSIONER BE ADJUSTED FOR FRONT AND REAR WINCH?
 - a. Attempt to adjust automatic brake setscrew for front winch (Volume 4, WP 0672).
 - b. Attempt to adjust drag brake for front winch (Volume 4, WP 0673).

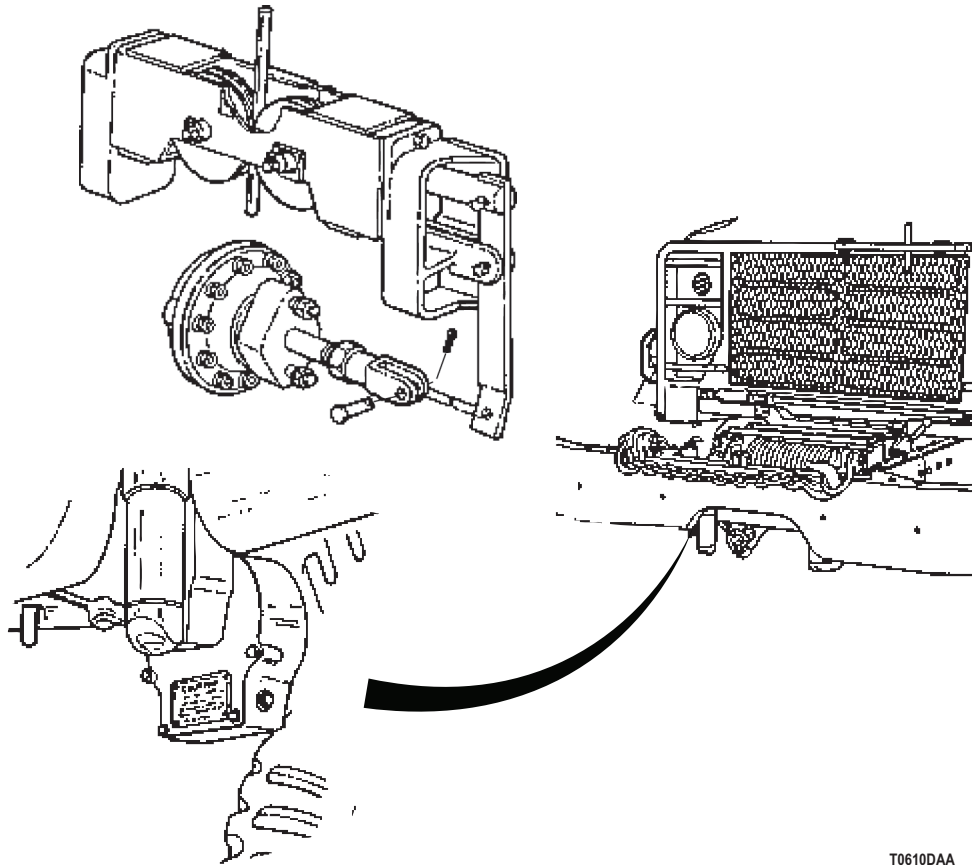
WINCH WILL NOT HOLD LOAD - Continued

T0610DAA

Figure 2. Front And Rear Winches.

- c. Attempt to adjust winch cable tensioner for rear winch (Volume 4, WP 0669).

CONDITION/INDICATION

CAN BRAKE SETSCREW AND WINCH CABLE TENSIONER BE ADJUSTED FOR FRONT AND REAR WINCH?

DECISION

YES - Both front and rear winches can be adjusted. Go to Step (3) to verify problem has been solved.

NO - Front winch brake cannot be adjusted. Replace front winch (Volume 4, WP 0668). Go to Step (3) to verify problem is solved.

NO - Rear winch cable tensioner cannot be adjusted. Repair rear winch tensioner (Volume 4, WP 0722). Go to Step (3) to verify problem is solved.

WINCH WILL NOT HOLD LOAD - Continued**STEP**

3. IS YOUR ORIGINAL WINCH HOLDING LOAD PROBLEM STILL PRESENT?
 - a. Ensure vehicle is returned to normal operating condition.
 - b. Check to see if your original winch holding load problem still exists.

CONDITION/INDICATION

IS YOUR ORIGINAL WINCH HOLDING LOAD PROBLEM STILL PRESENT?

DECISION

YES - Notify supervisor.
NO - Problem fixed.

END OF WORK PACKAGE

**FIELD MAINTENANCE
AUTOMATIC BRAKE OVERHEATS**

INITIAL SETUP:**Tools and Special Tools**

Tool Kit, General Mechanic's: Automotive
(Volume 5, WP 0826, Table 1, Item 56)

Personnel Required

(2)

References

Point to Point Schematics

References (cont.)

Volume 4, WP 0668
Volume 4, WP 0669
Volume 4, WP 0672
Volume 4, WP 0722

Equipment Condition

Vehicle parked and engine shut down.
(TM 9-2320-272-10)

TROUBLESHOOTING PROCEDURE**AUTOMATIC BRAKE OVERHEATS****NOTE**

Conduct these malfunction tests if winch automatic brake overheats. This procedure will check for proper load size and automatic brake adjustment.

AUTOMATIC BRAKE OVERHEATS - Continued**STEP**

1. IS WINCH LOAD WITHIN WEIGHT LIMITS?

NOTE

- Front winch load is limited to 20,000 lb.
- Rear winch load is limited to 45,000 lb.

Check weight limits of winch.

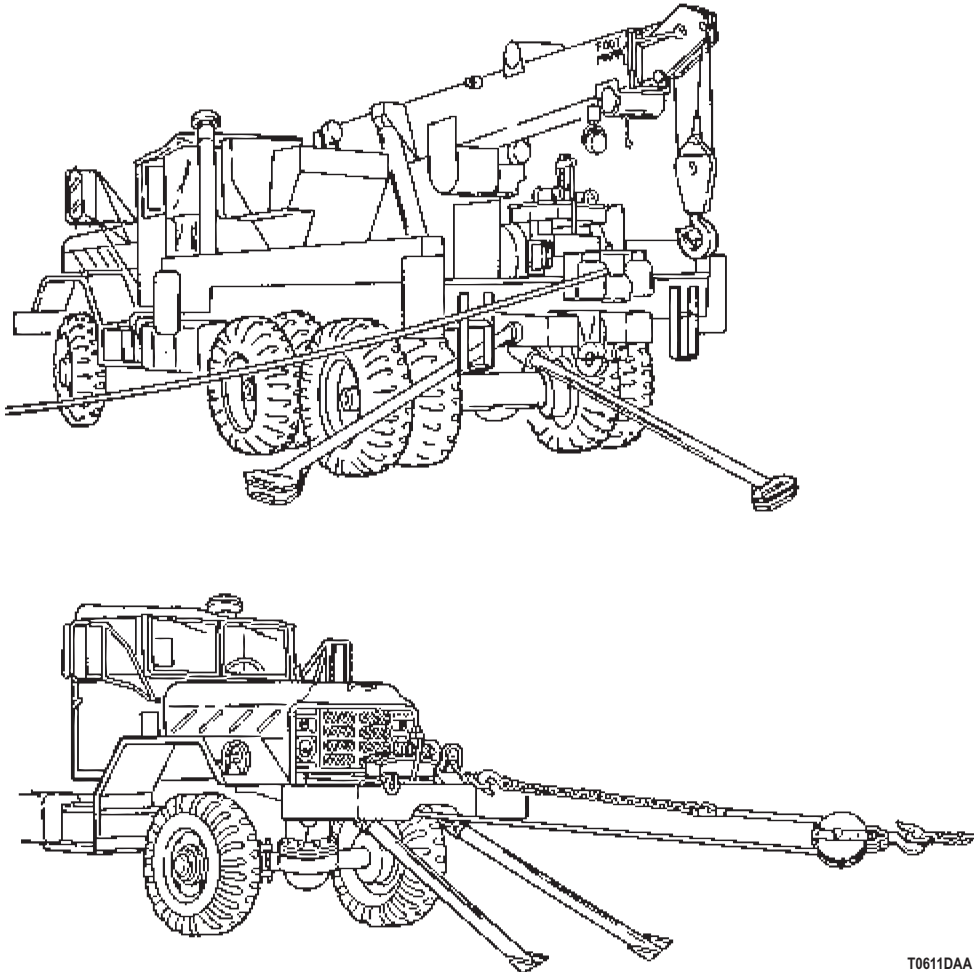

Figure 1. Front and Rear Winch.

CONDITION/INDICATION

IS WINCH LOAD WITHIN WEIGHT LIMITS?

DECISION

YES - Go to Step (2).

NO - Adjust load. Go to Step (3) to verify problem is solved.

AUTOMATIC BRAKE OVERHEATS - Continued**STEP**

2. CAN AUTOMATIC BRAKE SETSCREW AND WINCH CABLE TENSIONER BE ADJUSTED FOR FRONT AND REAR WINCH?
 - a. Attempt to adjust automatic brake setscrew for front winch (Volume 4, WP 0672).

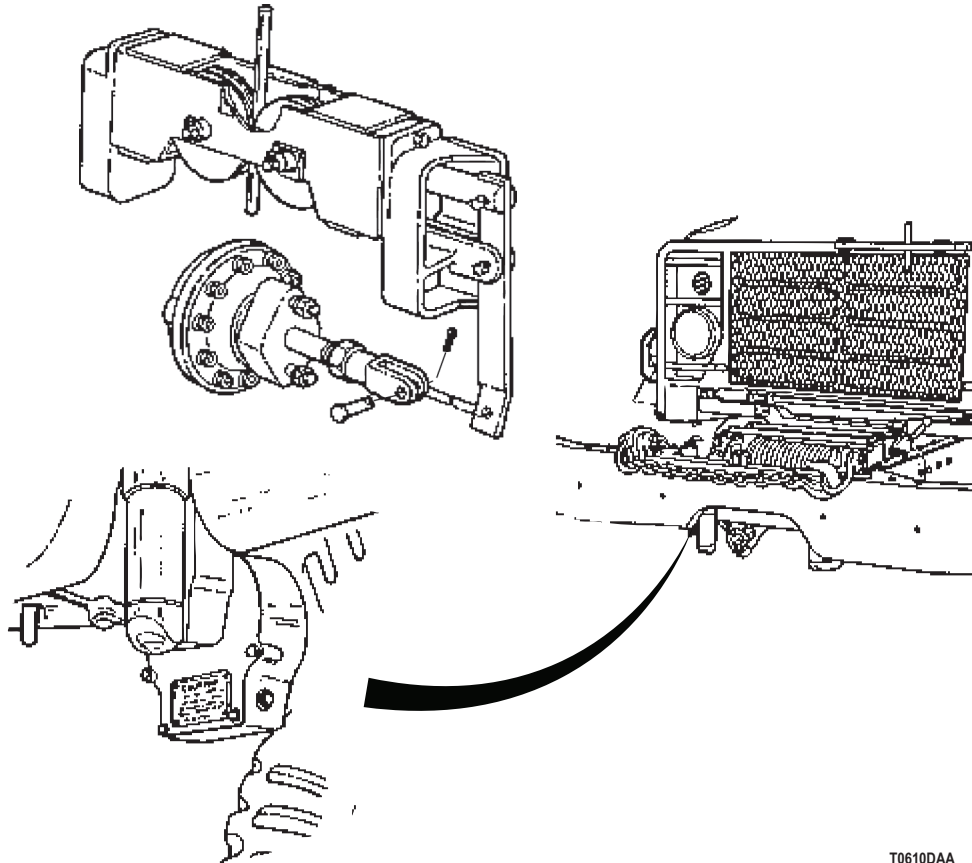

T0610DAA

Figure 2. Automatic Brake Setscrew.

- b. Attempt to adjust winch cable tensioner for rear winch (Volume 4, WP 0669).

CONDITION/INDICATION

CAN AUTOMATIC BRAKE SETSCREW AND WINCH CABLE TENSIONER BE ADJUSTED FOR FRONT AND REAR WINCH?

DECISION

YES - Both front and rear winches can be adjusted. Go to Step (3) to verify problem has been solved.
 NO - Front winch brake cannot be adjusted. Replace front winch (Volume 4, WP 0668). Go to Step (3) to verify problem is solved.
 NO - Rear winch cable tensioner cannot be adjusted. Repair rear winch tensioner (Volume 4, WP 0722). Go to Step (3) to verify problem is solved.

AUTOMATIC BRAKE OVERHEATS - Continued**STEP**

3. IS YOUR ORIGINAL PROBLEM STILL PRESENT?
 - a. Ensure vehicle is returned to normal operating condition.
 - b. Check to see if your original problem still exists.

CONDITION/INDICATION

IS YOUR ORIGINAL PROBLEM STILL PRESENT?

DECISION

YES - Notify supervisor.
NO - Problem fixed.

END OF WORK PACKAGE

**FIELD MAINTENANCE
FRONT WINCH OPERATES AT ONE SPEED ONLY**

INITIAL SETUP:**Tools and Special Tools**

Tool Kit, General Mechanic's: Automotive
(Volume 5, WP 0826, Table 1, Item 56)
Test Set, Electronic Systems
(Volume 5, WP 0826, Table 1, Item 51)

References (cont.)

Volume 2, WP 0270
Volume 4, WP 0680

Personnel Required

(2)

Equipment Condition

Vehicle parked and engine shut down.
(TM 9-2320-272-10)

References

Point to Point Schematics

TROUBLESHOOTING PROCEDURE**FRONT WINCH OPERATES AT ONE SPEED ONLY****NOTE**

Conduct these malfunction tests if winch operates at one speed only. This procedure will check for a damaged or leaking winch control valve, winch control cable, and throttle control cable.

FRONT WINCH OPERATES AT ONE SPEED ONLY - Continued**STEP****1. IS CONTROL VALVE IN GOOD CONDITION?**

Visually check front winch control valve for damage and leaks.

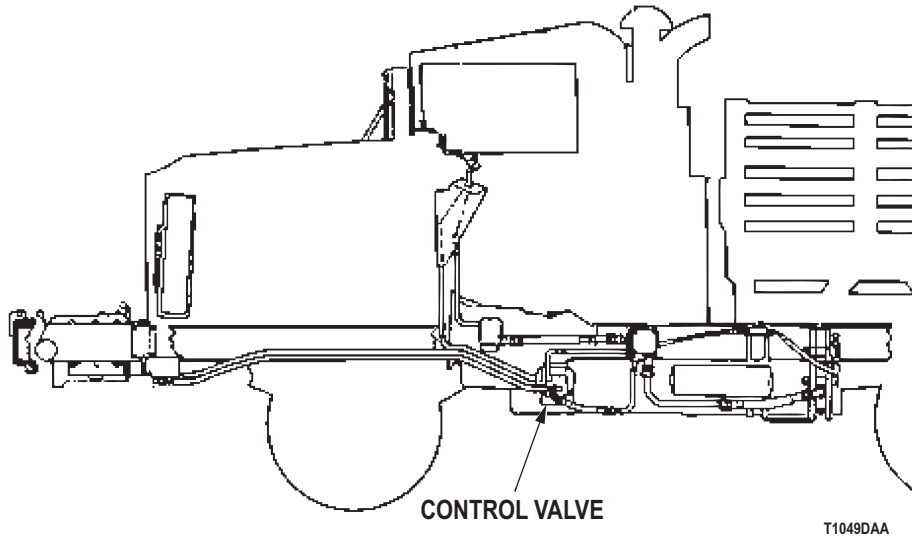

Figure 1. Winch Control Valve.

CONDITION/INDICATION

IS CONTROL VALVE IN GOOD CONDITION?

DECISION

YES - Go to Step (2).

NO - Replace control valve (Volume 4, WP 0681).

FRONT WINCH OPERATES AT ONE SPEED ONLY - Continued**STEP****2. IS WINCH CONTROL CABLE IN GOOD CONDITION?**

Visually inspect winch control cable for damage.

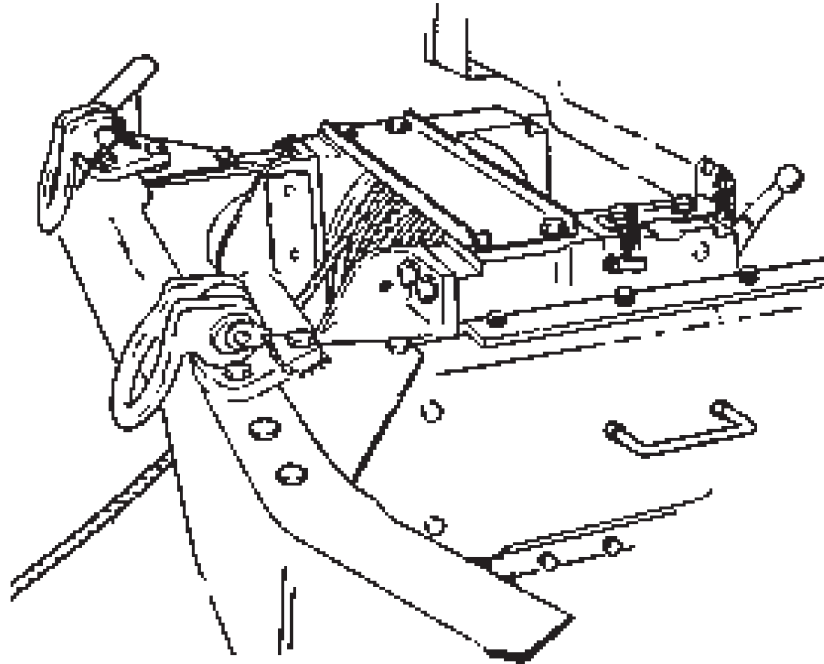

T1048DAA

Figure 2. Front Winch.

CONDITION/INDICATION

IS WINCH CONTROL CABLE IN GOOD CONDITION?

DECISION

YES - Go to Step (3).

NO - Replace control cable (Volume 4, WP 0680).

FRONT WINCH OPERATES AT ONE SPEED ONLY - Continued**STEP****3. IS THROTTLE CONTROL CABLE IN GOOD OPERATING CONDITION?**

Visually inspect throttle control cable for any sign of damage.

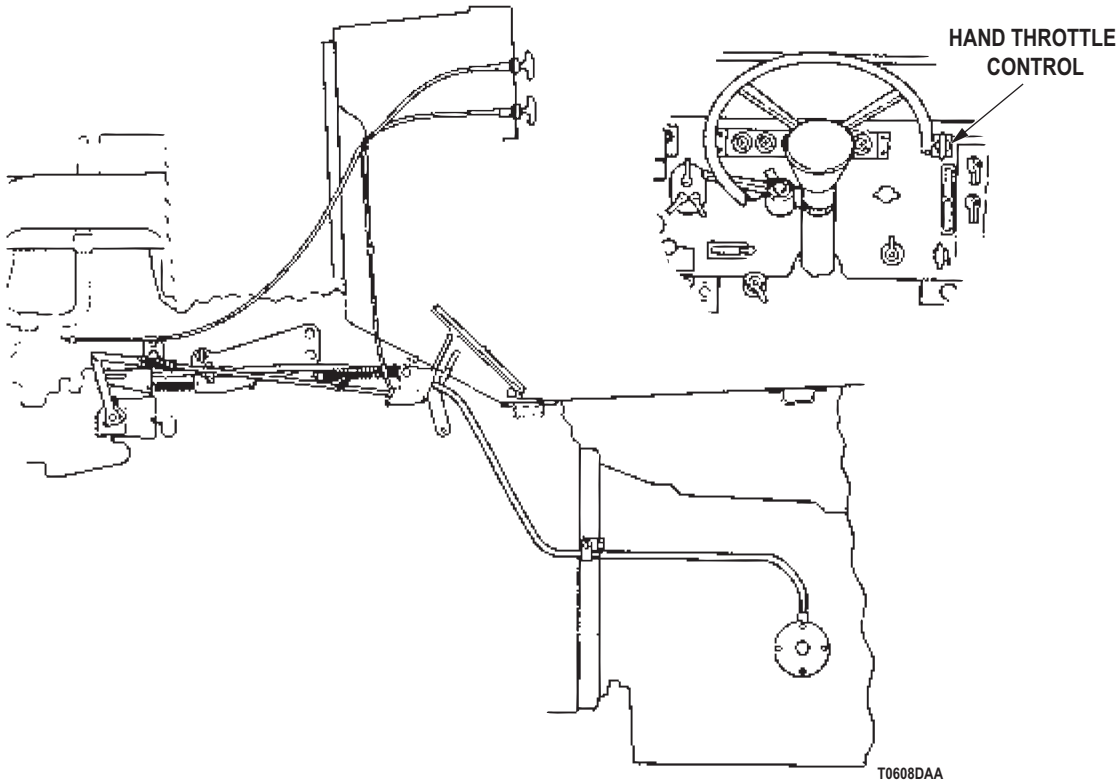

Figure 3. Throttle Control Cable.

CONDITION/INDICATION

IS THROTTLE CONTROL CABLE IN GOOD OPERATING CONDITION?

DECISION

YES - Go to Step (4) to verify problem is solved.

NO - Replace throttle control cable (Volume 2, WP 0270).

FRONT WINCH OPERATES AT ONE SPEED ONLY - Continued**STEP**

4. IS YOUR ORIGINAL WINCH PROBLEM STILL PRESENT?
 - a. Ensure vehicle is returned to normal operating condition.
 - b. Check to see if your original winch problem still exists.

CONDITION/INDICATION

IS YOUR ORIGINAL WINCH PROBLEM STILL PRESENT?

DECISION

YES - Notify supervisor.
NO - Problem fixed.

END OF WORK PACKAGE

FIELD MAINTENANCE
REAR WINCH CABLE TENSIONER WILL NOT OPERATE

INITIAL SETUP:**Tools and Special Tools**

Tool Kit, General Mechanic's: Automotive
(Volume 5, WP 0826, Table 1, Item 56)
Test Set, Electronic Systems
(Volume 5, WP 0826, Table 1, Item 51)

Personnel Required

(2)

References

Point to Point Schematics
Volume 5, WP 0805

Equipment Condition

Vehicle parked and engine shut down.
(TM 9-2320-272-10)

TROUBLESHOOTING PROCEDURE**REAR WINCH CABLE TENSIONER WILL NOT OPERATE****NOTE**

Conduct these malfunction tests if rear winch cable tensioner does not operate. This procedure will check for leaking air supply lines.

REAR WINCH CABLE TENSIONER WILL NOT OPERATE - Continued**STEP**

1. ARE AIR SUPPLY LINES IN GOOD CONDITION?
 - a. Check air supply lines for leaks.

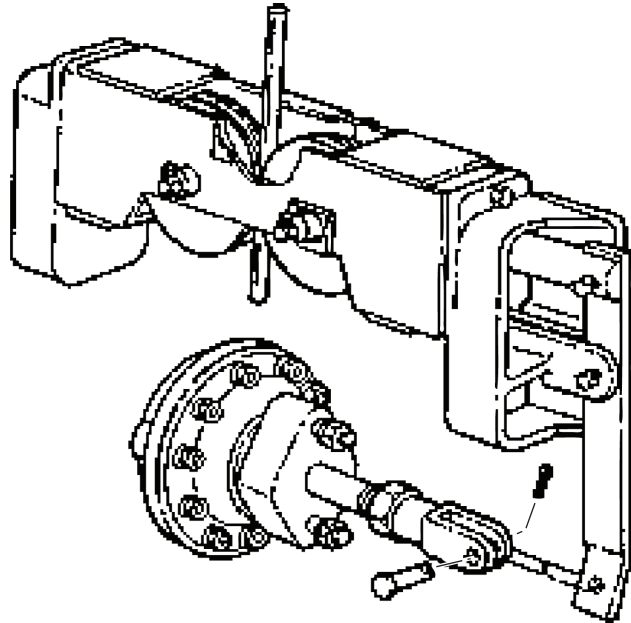

T0613DAA

Figure 1. Rear Winch Cable Tensioner.

NOTE

If air supply lines leaks after tightening fitting, Problem has not been solved.

- b. Tighten any loose fittings.

CONDITION/INDICATION

ARE AIR SUPPLY LINES IN GOOD CONDITION?

DECISION

YES - Go to Step (2) to verify problem is solved.

NO - Replace damaged air lines (Volume 5, WP 0805). Go to Step (2) to verify problem is solved.

STEP

2. IS YOUR ORIGINAL WINCH PROBLEM STILL PRESENT?
 - a. Ensure vehicle is returned to normal operating condition.
 - b. Check to see if your original winch problem still exists.

REAR WINCH CABLE TENSIONER WILL NOT OPERATE - Continued

CONDITION/INDICATION

IS YOUR ORIGINAL WINCH PROBLEM STILL PRESENT?

DECISION

YES - Notify supervisor.

NO - Problem fixed.

END OF WORK PACKAGE

FIELD MAINTENANCE
VEHICLE ROLLS WHILE OPERATING REAR WINCH

INITIAL SETUP:**Tools and Special Tools**

Tool Kit, General Mechanic's: Automotive
(Volume 5, WP 0826, Table 1, Item 56)

References (cont.)

TM 9-2320-272-10
Volume 3, WP 0420

Personnel Required

(2)

Equipment Condition

Vehicle parked and engine shut down.
(TM 9-2320-272-10)

References

Point to Point Schematics

TROUBLESHOOTING PROCEDURE**VEHICLE ROLLS WHILE OPERATING REAR WINCH****NOTE**

Conduct these malfunction tests if the vehicle rolls while operating the rear winch. This procedure will check the parking brake for proper adjustment, the spring brake for caging and the field chock positioning.

VEHICLE ROLLS WHILE OPERATING REAR WINCH - Continued**STEP****1. IS PARKING BRAKE PROPERLY ADJUSTED?**

Test parking brake for proper adjustment (Volume 3, WP 0420).

CONDITION/INDICATION

IS PARKING BRAKE PROPERLY ADJUSTED?

DECISION

YES - Go to Step (2).

NO - Adjust parking brake (Volume 3, WP 0420). Go to Step (4) to verify problem is solved.

STEP**2. IS SPRING BRAKE CAGE RELEASED?**

Visually check if spring brake cage is released.

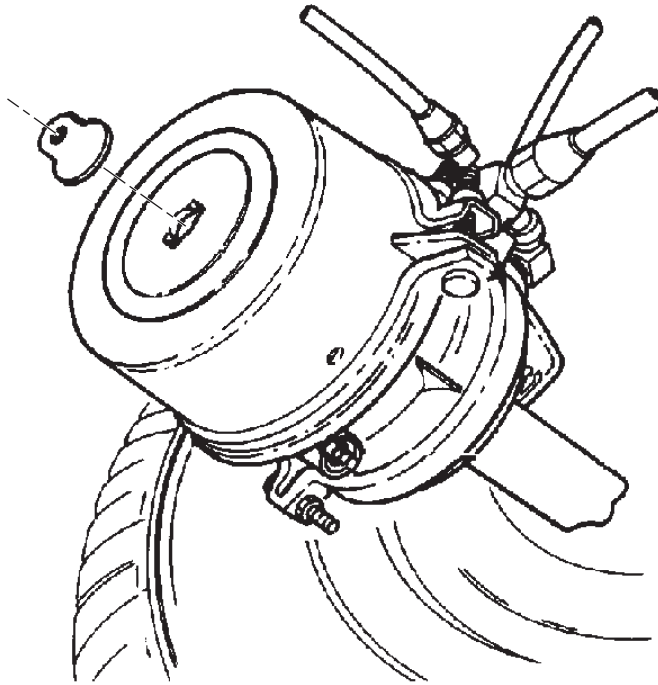

T0617DAA

Figure 1. Spring Brake.

CONDITION/INDICATION

IS SPRING BRAKE CAGE RELEASED?

DECISION

YES - Go to Step (3).

NO - Release brakes (TM 9-2320-272-10). Go to Step (4) to verify problem is solved.

VEHICLE ROLLS WHILE OPERATING REAR WINCH - Continued**STEP****3. IS FIELD CHOCK IN CORRECT POSITION?**

Visually check chock positioning. Field chocks should be facing load.

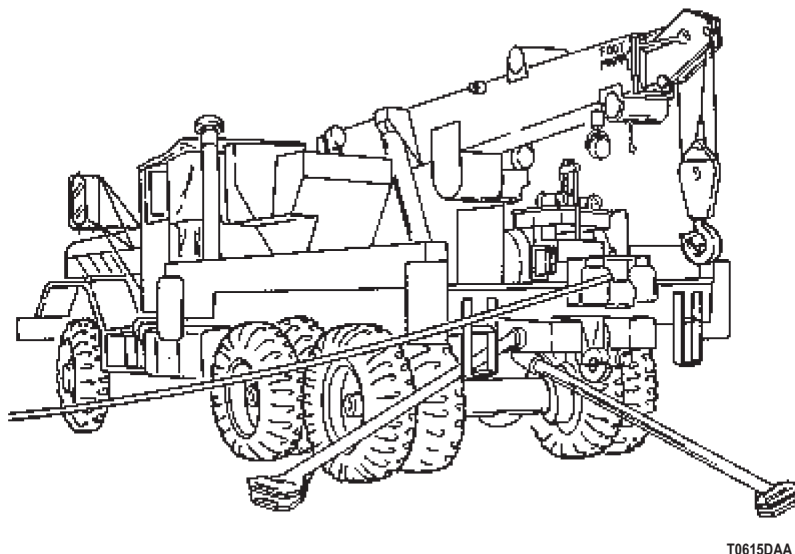

T0615DAA

Figure 2. Field Chocks.

CONDITION/INDICATION

IS FIELD CHOCK IN CORRECT POSITION?

DECISION

YES - Go to Step (4) to verify problem is solved.

NO - Reposition chocks (TM 9-2320-272-10). Go to Step (4) to verify problem is solved.

STEP**4. IS YOUR ORIGINAL VEHICLE ROLLING PROBLEM STILL PRESENT?**

- a. Ensure vehicle is returned to normal operating condition.
- b. Check to see if your original vehicle rolling problem still exists.

CONDITION/INDICATION

IS YOUR ORIGINAL VEHICLE ROLLING PROBLEM STILL PRESENT?

DECISION

YES - Notify supervisor.

NO - Problem fixed.

END OF WORK PACKAGE

**FIELD MAINTENANCE
PTO EXCESSIVELY NOISY**

INITIAL SETUP:**Tools and Special Tools**

Tool Kit, General Mechanic's: Automotive
(Volume 5, WP 0826, Table 1, Item 56)

References (cont.)

Volume 4, WP 0713
Volume 4, WP 0714
Volume 5, WP 0820

Personnel Required

(2)

Equipment Condition

Vehicle parked and engine shut down.
(TM 9-2320-272-10)

References

Point to Point Schematics

TROUBLESHOOTING PROCEDURE**PTO EXCESSIVELY NOISY****NOTE**

Conduct these malfunction tests if there is excessive noise at the transmission or transfer case power takeoff. This procedure will check universal joints for proper lubrication and propeller shafts for bends.

PTO EXCESSIVELY NOISY - Continued**STEP****1. IS PTO UNIVERSAL JOINT PROPERLY LUBRICATED?**

Visually inspect PTO universal joint for proper lubrication.

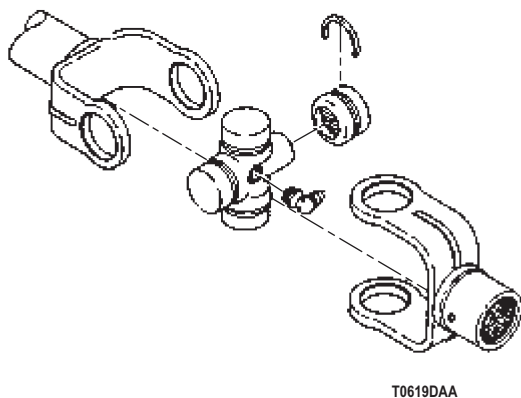

Figure 1. PTO Universal Joint.

CONDITION/INDICATION

IS PTO UNIVERSAL JOINT PROPERLY LUBRICATED?

DECISION

YES - Go to Step (2).

NO - Lubricate PTO universal joints (Volume 5, WP 0820). Go to Step (4) to verify problem is solved.

PTO EXCESSIVELY NOISY - Continued**STEP****2. IS TRANSMISSION PTO TO HYDRAULIC PUMP PROPELLER SHAFT BENT?**

Visually inspect propeller shaft for bend.

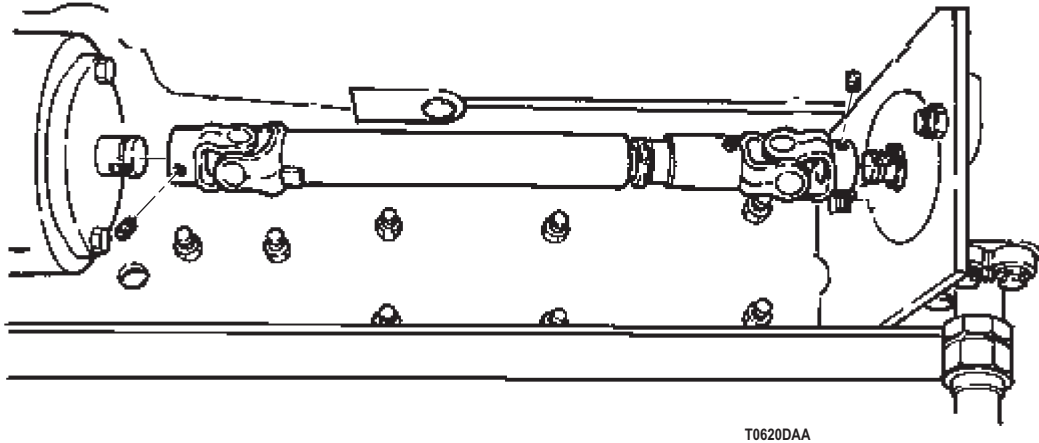

Figure 2. Transmission PTO to Hydraulic Pump Propeller Shaft.

CONDITION/INDICATION

IS PTO UNIVERSAL JOINT PROPERLY LUBRICATED?

DECISION

YES - Go to Step (3).

NO - Replace bent propeller shaft (Volume 4, WP 0713). Go to Step (4) to verify problem is solved.

PTO EXCESSIVELY NOISY - Continued**STEP****3. IS TRANSFER CASE PTO TO HYDRAULIC PUMP PROPELLER SHAFT BENT?**

Visually inspect propeller shaft for bend.

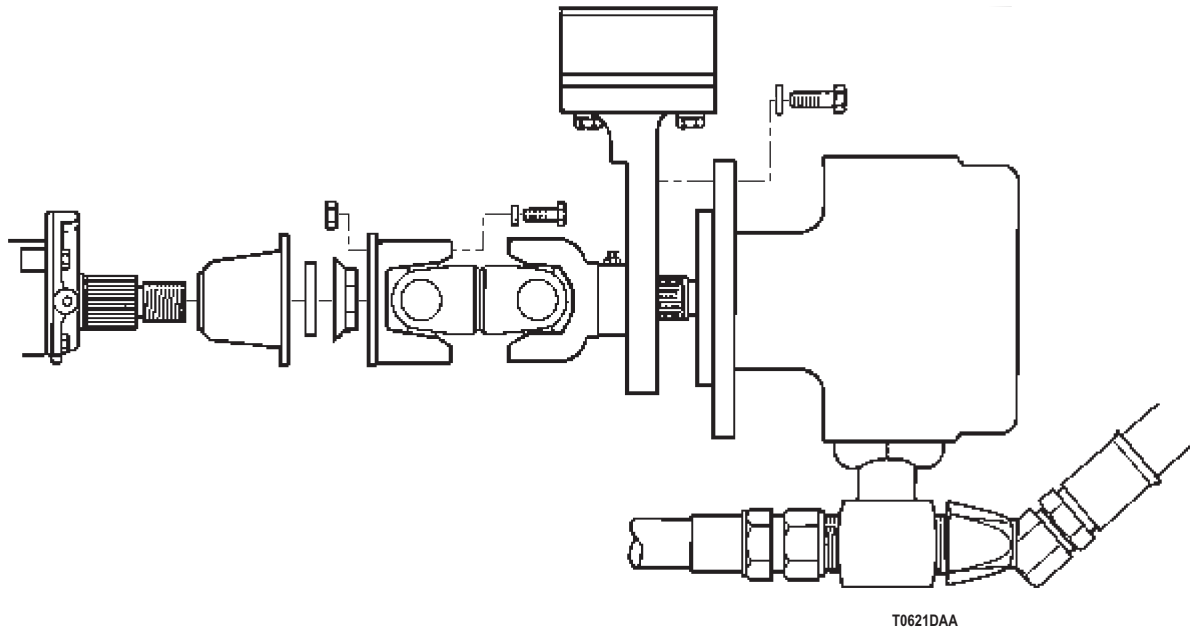

Figure 3. Transfer Case PTO to Hydraulic Pump Propeller Shaft.

CONDITION/INDICATION

IS TRANSFER CASE PTO TO HYDRAULIC PUMP PROPELLER SHAFT BENT?

DECISION

YES - Go to Step (4) to verify problem is solved.

NO - Replace bent propeller shaft (Volume 4, WP 0714). Go to Step (4) to verify problem is solved.

PTO EXCESSIVELY NOISY - Continued**STEP**

4. IS YOUR ORIGINAL NOISE AT POWER TAKEOFF PROBLEM STILL PRESENT?
 - a. Ensure vehicle is returned to normal operating condition.
 - b. Check to see if your original noise at power takeoff problem still exists.

CONDITION/INDICATION

IS YOUR ORIGINAL NOISE AT POWER TAKEOFF PROBLEM STILL PRESENT?

DECISION

YES - Notify supervisor.
NO - Problem fixed.

END OF WORK PACKAGE

**FIELD MAINTENANCE
PTO SHIFTS HARD**

INITIAL SETUP:**Tools and Special Tools**

Tool Kit, General Mechanic's: Automotive
(Volume 5, WP 0826, Table 1, Item 56)

References (cont.)

Volume 4, WP 0729
Volume 4, WP 0730
Volume 5, WP 0820

Personnel Required

(2)

Equipment Condition

Vehicle parked and engine shut down.
(TM 9-2320-272-10)

References

Point to Point Schematics

TROUBLESHOOTING PROCEDURE

PTO SHIFTS HARD**STEP****1. IS PTO SHIFT LINKAGE PROPERLY LUBRICATED?**

Visually inspect PTO shift linkage for proper lubrication.

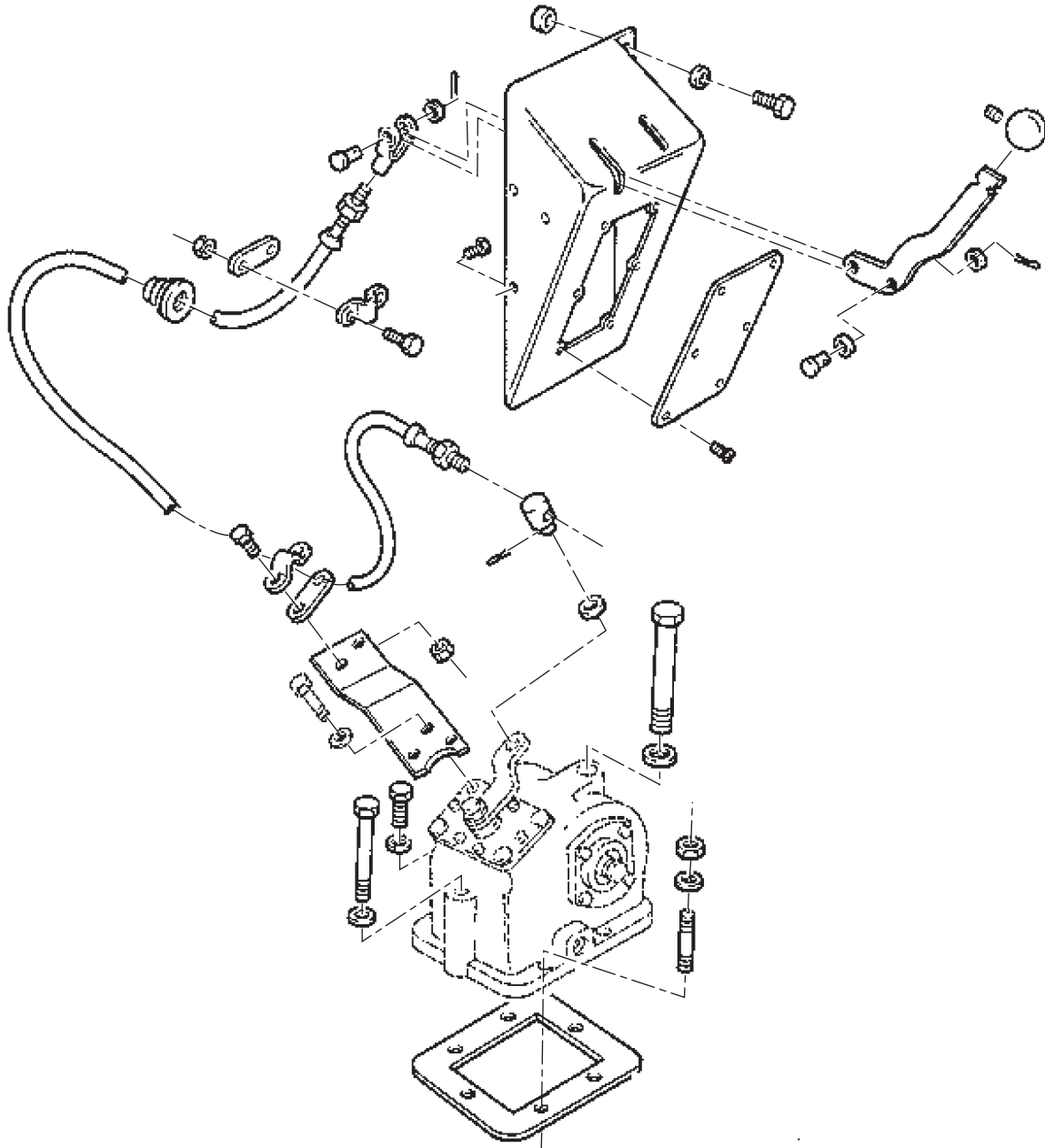

T0623DAA

Figure 1. PTO Shift Linkage.

PTO SHIFTS HARD - Continued**CONDITION/INDICATION**

IS PTO SHIFT LINKAGE PROPERLY LUBRICATED?

DECISION

YES - Go to Step (2).

NO - Lubricate PTO shift linkage (Volume 5, WP 0820). Go to Step (3) to verify problem is solved.

PTO SHIFTS HARD - Continued

STEP

2. IS PTO SHIFT LINKAGE IN GOOD OPERATING CONDITION?

Visually inspect PTO shift linkage for bends, cracks, and loose, damaged or missing hardware.

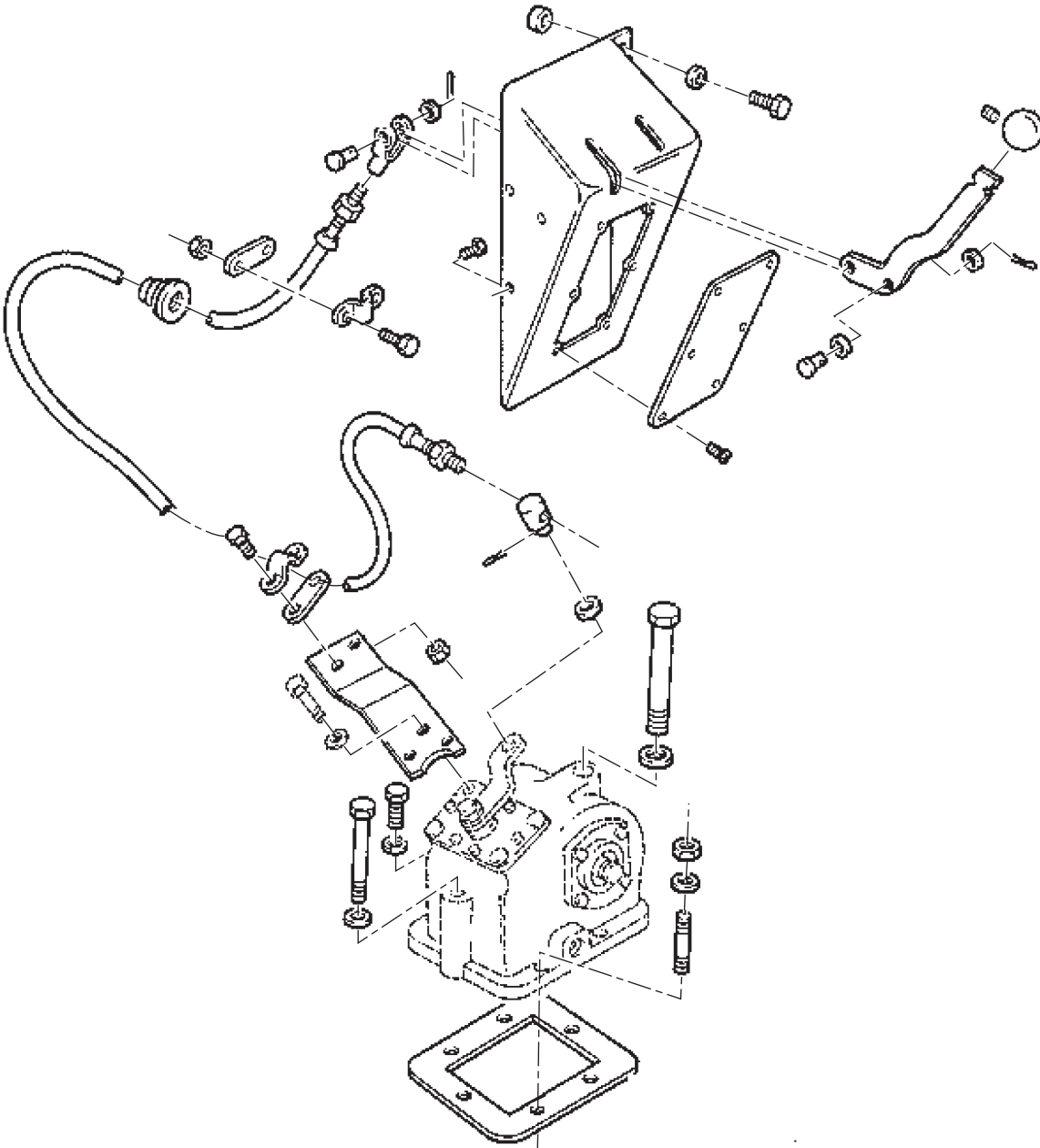

T0623DAA

Figure 2. PTO Shift Linkage Condition.

PTO SHIFTS HARD - Continued**CONDITION/INDICATION**

IS PTO SHIFT LINKAGE IN GOOD OPERATING CONDITION?

DECISION

YES - Go to Step (3) to verify problem is solved.

NO - Replace transmission PTO cable M939/A1 (Volume 4, WP 0729), M939A2 (Volume 4, WP 0730). Go to Step (3) to verify problem is solved.

STEP

3. IS YOUR ORIGINAL HARD SHIFTING OF POWER TAKEOFF PROBLEM STILL PRESENT?
 - a. Ensure vehicle is returned to normal operating condition.
 - b. Check to see if your original hard shifting of power takeoff problem still exists.

CONDITION/INDICATION

IS YOUR ORIGINAL HARD SHIFTING OF POWER TAKEOFF PROBLEM STILL PRESENT?

DECISION

YES - Notify supervisor.

NO - Problem fixed.

END OF WORK PACKAGE

**FIELD MAINTENANCE
PTO LEAKING LUBRICANT**

INITIAL SETUP:**Tools and Special Tools**

Tool Kit, General Mechanic's: Automotive
(Volume 5, WP 0826, Table 1, Item 56)

Equipment Condition

Vehicle parked and engine shut down.
(TM 9-2320-272-10)

Personnel Required

(2)

References

Point to Point Schematics
Volume 4, WP 0728

TROUBLESHOOTING PROCEDURE**PTO LEAKING LUBRICANT****NOTE**

Conduct these malfunction tests if lubrication is leaking at PTO. This procedure will check PTO for loose mounting screws.

PTO LEAKING LUBRICANT - Continued**STEP**

1. ARE MOUNTING SCREWS LOOSE?
 - a. Inspect PTO mounting screws for looseness.
 - b. Tighten any loose PTO mounting screws.

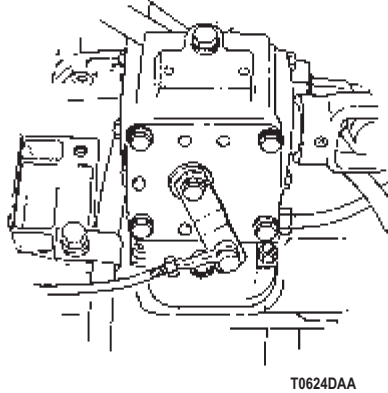

Figure 1. PTO Mounting Screws.

- c. Visually inspect PTO for lubricant leaks.

CONDITION/INDICATION

ARE MOUNTING SCREWS LOOSE?

DECISION

- YES - Tighten loose screws (Volume 4, WP 0728). Go to Step (2) to verify problem is solved.
 NO - Go to Step (2) to verify problem is solved.

STEP

2. IS YOUR ORIGINAL LEAKING LUBRICANT AT POWER TAKEOFF PROBLEM STILL PRESENT?
 - a. Ensure vehicle is returned to normal operating condition.
 - b. Check to see if your original leaking at power takeoff problem still exists.

CONDITION/INDICATION

IS YOUR ORIGINAL LEAKING LUBRICANT AT POWER TAKEOFF PROBLEM STILL PRESENT?

DECISION

- YES - Notify supervisor.
 NO - Problem fixed.

END OF WORK PACKAGE

**FIELD MAINTENANCE
RADIO INTERFERENCE**

INITIAL SETUP:**Tools and Special Tools**

Tool Kit, General Mechanic's: Automotive
(Volume 5, WP 0826, Table 1, Item 56)
Test Set, Electronic Systems
(Volume 5, WP 0826, Table 1, Item 51)

References (cont.)

Volume 2, WP 0300
Volume 2, WP 0301
Volume 3, WP 0352
Volume 5, WP 0780

Personnel Required

(2)

Equipment Condition

Vehicle parked and engine shut down.
(TM 9-2320-272-10)

References

Point to Point Schematics

TROUBLESHOOTING PROCEDURE**RADIO INTERFERENCE****NOTE**

Conduct these malfunction tests if there is radio interference. This track will check alternator and associated wiring.

RADIO INTERFERENCE - Continued**STEP****1. IS ALTERNATOR WIRING IN GOOD CONDITION?**

- a. Inspect alternator wiring for defects.

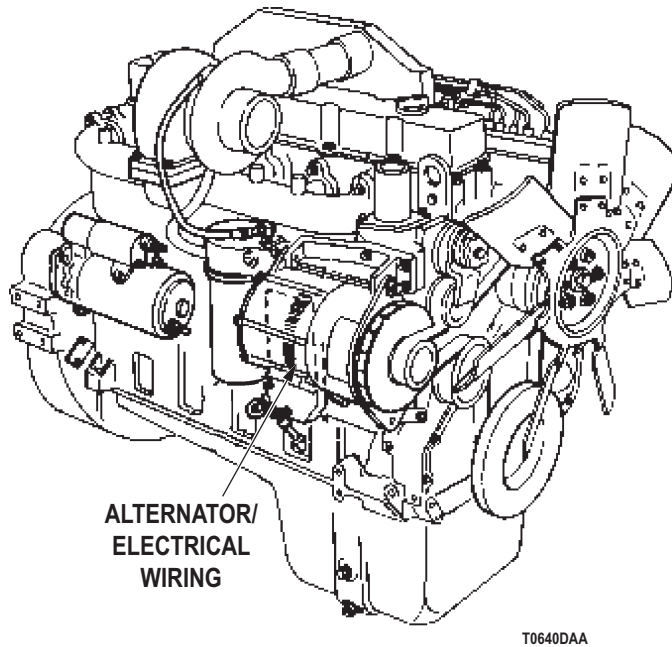

Figure 1. Alternator Wiring.

- b. Inspect starter/battery wiring for frays, loose or broken connections, refer to point to point schematic.
- c. Inspect horn wiring for frays, loose or broken connections, refer to point to point schematic.
- d. Inspect transmission wiring for frays, loose or broken connections, refer to point to point schematic.
- e. Inspect wiring for cracked, worn, or missing insulation.

CONDITION/INDICATION

IS ALTERNATOR WIRING IN GOOD CONDITION?

DECISION

YES - Go to Step (2).

NO - Repair wiring as needed (Volume 3, WP 0352). Go to Step (3) to verify problem is solved.

RADIO INTERFERENCE - Continued**STEP****2. IS ALTERNATOR IN GOOD OPERATING CONDITION?****NOTE**

Prevent open wires from touching each other, or any metal part.

- a. Disconnect harness connector from alternator. Refer to point to point schematics.
 - (1) M939/A1 60 amp alternator (Volume 2, WP 0300).
 - (2) M939A2 60 amp alternator (Volume 2, WP 0301).
 - (3) 100 amp alternator (Volume 5, WP 0780).

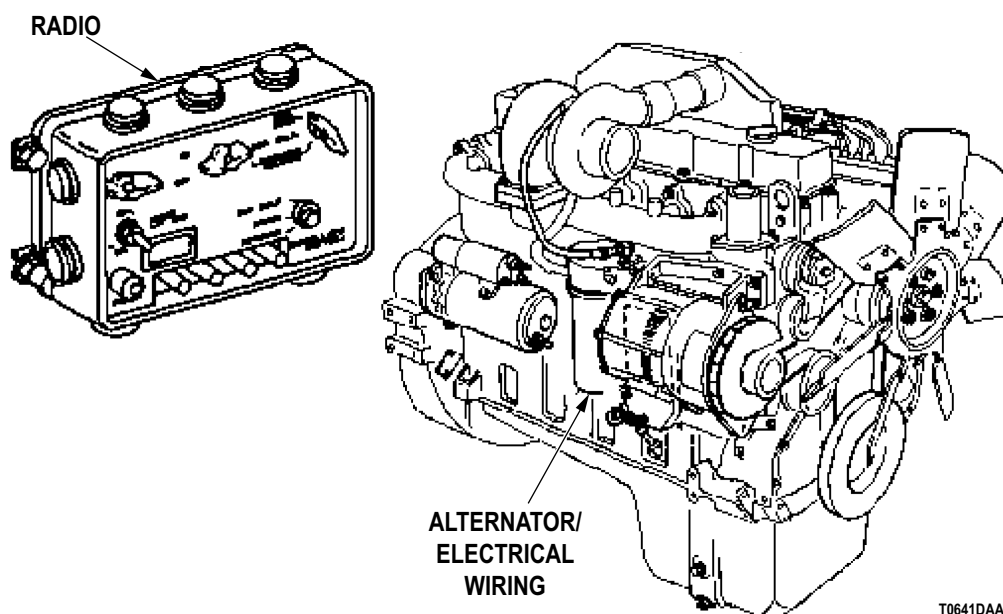

Figure 2. Alternator.

- b. Start engine.

NOTE

If no interference is heard, alternator is faulty.

- c. Listen to radio for interference.

CONDITION/INDICATION

IS ALTERNATOR IN GOOD OPERATING CONDITION?

DECISION

YES - Notify supervisor. Action may not be possible at this level of maintenance.

NO - Replace faulty alternator M939/A1 60 amp (Volume 2, WP 0300), M939A2 60 amp (Volume 2, WP 0301), 100 amp (Volume 5, WP 0780). Go to Step (3) to verify problem is solved.

RADIO INTERFERENCE - Continued**STEP**

3. IS YOUR ORIGINAL PROBLEM STILL PRESENT?
 - a. Ensure vehicle is returned to normal operating condition.
 - b. Check to see if your original problem still exists.

CONDITION/INDICATION

IS YOUR ORIGINAL PROBLEM STILL PRESENT?

DECISION

YES - Notify supervisor.
NO - Problem fixed.

END OF WORK PACKAGE

**FIELD MAINTENANCE
TRAILER WILL NOT HITCH TO FIFTH WHEEL**

INITIAL SETUP:**Tools and Special Tools**

Tool Kit, General Mechanic's: Automotive
(Volume 5, WP 0826, Table 1, Item 56)

References

Volume 3, WP 0530

Personnel Required

(2)

Equipment Condition

Vehicle parked and engine shut down.
(TM 9-2320-272-10)

TROUBLESHOOTING PROCEDURE**TRAILER WILL NOT HITCH TO FIFTH WHEEL****NOTE**

Conduct this malfunction test if trailer will not hitch to fifth wheel. This procedure will check coupling jaws for bends and breaks.

TRAILER WILL NOT HITCH TO FIFTH WHEEL - Continued**STEP****1. ARE COUPLING JAWS IN GOOD OPERATING CONDITION?**

Visually inspect coupling jaws for bends and breaks.

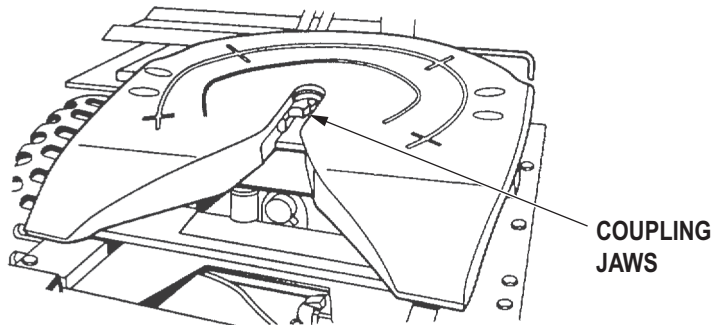

T0643DAA

Figure 1. Fifth Wheel.

CONDITION/INDICATION

ARE COUPLING JAWS IN GOOD OPERATING CONDITION?

DECISION

YES - Go to Step (2) to verify problem is solved.

NO - Replace damaged fifth wheel (Volume 3, WP 0530). Go to Step (2) to verify problem is solved.

STEP**2. IS YOUR ORIGINAL FIFTH WHEEL HITCHING PROBLEM STILL PRESENT?**

- a. Ensure vehicle is returned to normal operating condition.
- b. Check to see if your original fifth hitching problem still exists.

CONDITION/INDICATION

IS YOUR ORIGINAL FIFTH WHEEL HITCHING PROBLEM STILL PRESENT?

DECISION

YES - Notify supervisor.

NO - Problem fixed.

END OF WORK PACKAGE

**FIELD MAINTENANCE
WRECKER HYDRAULIC SYSTEM DOES NOT OPERATE**

INITIAL SETUP:**Tools and Special Tools**

Tool Kit, General Mechanic's: Automotive
(Volume 5, WP 0826, Table 1, Item 56)
Test Set, Electronic Systems
(Volume 5, WP 0826, Table 1, Item 51)

References (cont.)

TM 9-2320-272-10
Volume 4, WP 0711
Volume 4, WP 0728
Volume 5, WP 0820

Personnel Required

(2)

Equipment Condition

Vehicle parked and engine shut down.
(TM 9-2320-272-10)

References

Point to Point Schematics

TROUBLESHOOTING PROCEDURE**WRECKER HYDRAULIC SYSTEM DOES NOT OPERATE****NOTE**

- Conduct these malfunction tests if hydraulic system does not operate. This procedure will check for improper oil level, power takeoff condition, hydraulic lines for leaks and oil leaks from reservoir drain plug and valves.
- Rear winch controls must be in neutral for crane operation.

WRECKER HYDRAULIC SYSTEM DOES NOT OPERATE - Continued**STEP****1. IS HYDRAULIC OIL LEVEL AT PROPER LEVEL?**

Check reservoir for proper level.

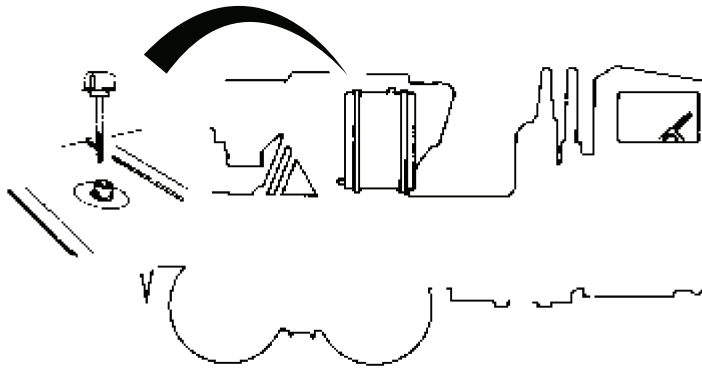

T0871DAA

Figure 1. Hydraulic Oil Reservoir.

CONDITION/INDICATION

IS HYDRAULIC OIL LEVEL AT PROPER LEVEL?

DECISION

YES - Go to Step (2).

NO - Fill reservoir to proper level (Volume 5, WP 0820). Go to Step (5) verify problem is solved.

WRECKER HYDRAULIC SYSTEM DOES NOT OPERATE - Continued**STEP****2. DOES POWER TAKEOFF ENGAGE?**

Engage power takeoff (TM 9-2320-272-10).

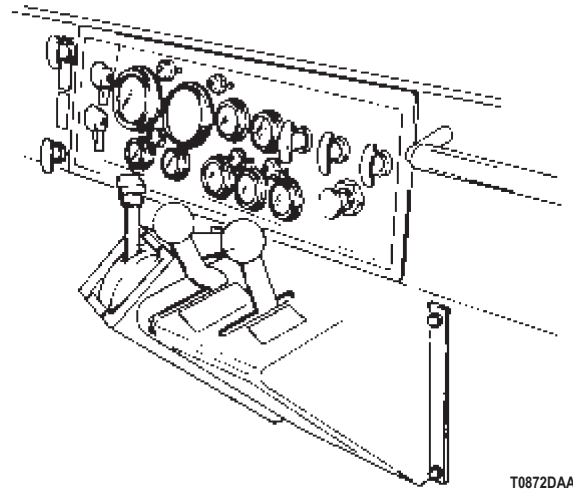

Figure 2. Power Takeoff Controls.

CONDITION/INDICATION

DOES POWER TAKEOFF ENGAGE?

DECISION

YES - Go to Step (3).

NO - Replace transmission power takeoff (Volume 4, WP 0728). Go to Step (5) to verify problem is solved.

WRECKER HYDRAULIC SYSTEM DOES NOT OPERATE - Continued**STEP****3. ARE ALL OIL LINES IN GOOD OPERATING CONDITION?**

- a. Determine operating condition of all oil lines.
- b. Visually check all oil lines for damage and leaks. Refer to point to point schematics.

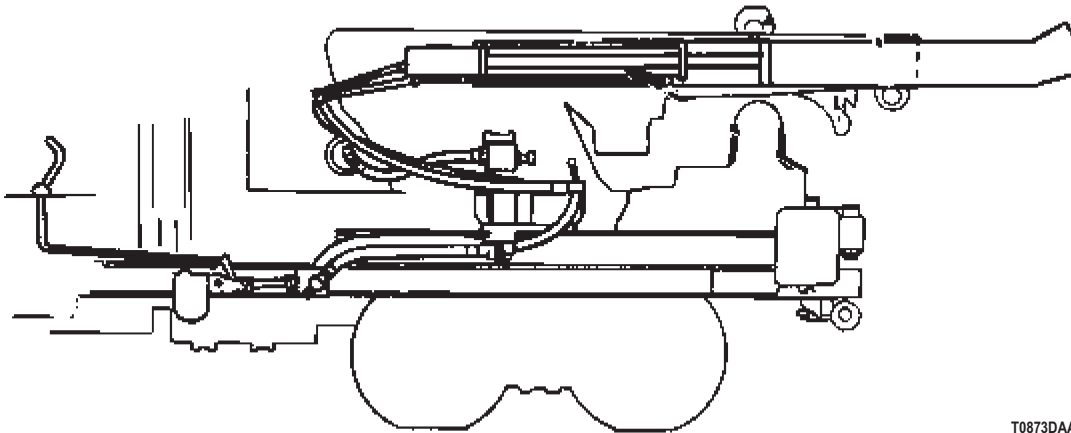

T0873DAA

Figure 3. Oil Lines.

- c. Tighten any loose fittings.

CONDITION/INDICATION

ARE ALL OIL LINES IN GOOD OPERATING CONDITION?

DECISION

YES - Go to Step (4).

NO - Replace damaged hoses (Volume 4, WP 0711). Go to Step (5) to verify problem is solved.

STEP**4. IS RESERVOIR LEAKING OIL?**

Visually inspect reservoir drain plug and valve for oil leaks.

CONDITION/INDICATION

IS RESERVOIR LEAKING OIL?

DECISION

YES - Reservoir valve is leaking, Close leaking valve. Go to Step (5) to verify problem is solved.

YES - Reservoir drain plug is leaking. Tighten leaking drain plug. Go to Step (5) to verify problem is solved.

NO - Go to Step (5) to verify problem is solved.

WRECKER HYDRAULIC SYSTEM DOES NOT OPERATE - Continued**STEP**

5. IS YOUR ORIGINAL HYDRAULIC SYSTEM PROBLEM STILL PRESENT?
 - a. Ensure vehicle is returned to normal operating condition.
 - b. Check to see if your original hydraulic system problem still exists.

CONDITION/INDICATION

IS YOUR ORIGINAL HYDRAULIC SYSTEM PROBLEM STILL PRESENT?

DECISION

YES - Notify supervisor.
NO - Problem fixed.

END OF WORK PACKAGE

**FIELD MAINTENANCE
WRECKER HYDRAULIC PUMP NOISY**

INITIAL SETUP:**Tools and Special Tools**

Tool Kit, General Mechanic's: Automotive
(Volume 5, WP 0826, Table 1, Item 56)

Equipment Condition

Vehicle parked and engine shut down.
(TM 9-2320-272-10)

Personnel Required

(2)

References

Point to Point Schematics
Volume 5, WP 0820

TROUBLESHOOTING PROCEDURE**WRECKER HYDRAULIC PUMP NOISY****NOTE**

Conduct this malfunction test if hydraulic pump is noisy. This procedure will check for hydraulic oil level.

WRECKER HYDRAULIC PUMP NOISY - Continued**STEP****1. IS HYDRAULIC OIL AT PROPER LEVEL?**

Check reservoir for proper level.

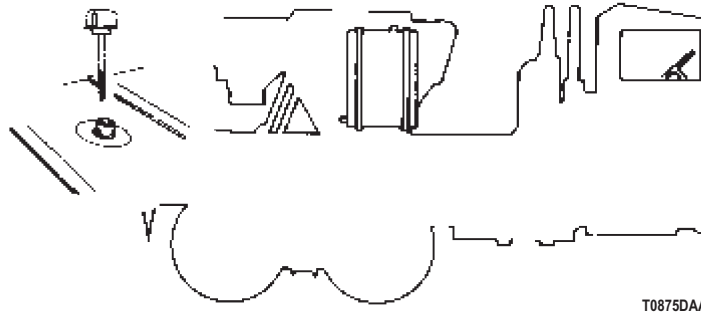

Figure 1. Hydraulic Oil Level.

CONDITION/INDICATION

IS HYDRAULIC OIL AT PROPER LEVEL?

DECISION

YES - Go to Step (2) to verify problem is solved.

NO - Fill reservoir to proper level (Volume 5, WP 0820). Go to Step (2) to verify problem is solved.

STEP**2. IS YOUR ORIGINAL HYDRAULIC PUMP PROBLEM STILL PRESENT?**

- a. Ensure vehicle is returned to normal operating condition.
- b. Check to see if your original hydraulic pump problem still exists.

CONDITION/INDICATION

IS YOUR ORIGINAL HYDRAULIC PUMP PROBLEM STILL PRESENT?

DECISION

YES - Notify supervisor.

NO - Problem fixed.

END OF WORK PACKAGE

**FIELD MAINTENANCE
DUMP BODY WILL NOT RAISE**

INITIAL SETUP:**Tools and Special Tools**

Tool Kit, General Mechanic's: Automotive
(Volume 5, WP 0826, Table 1, Item 56)
Test Set, Electronic Systems
(Volume 5, WP 0826, Table 1, Item 51)

References (cont.)

TM 9-2320-272-10
Volume 4, WP 0715
Volume 4, WP 0719
Volume 4, WP 0720

Personnel Required

(2)

Equipment Condition

Vehicle parked and engine shut down.
(TM 9-2320-272-10)

References

Point to Point Schematics

TROUBLESHOOTING PROCEDURE**DUMP BODY WILL NOT RAISE****NOTE**

Conduct these malfunction tests if dump body will not raise. This procedure will check for power takeoff condition, oil leaks from hydraulic lines or control valve, condition of control valve and pump housing for leaks or overheating with power takeoff engaged.

DUMP BODY WILL NOT RAISE - Continued**STEP**

1. DOES POWER TAKEOFF ENGAGE?
 - a. Check if power takeoff is engaged.
 - b. Engage power takeoff (TM 9-2320-272-10).

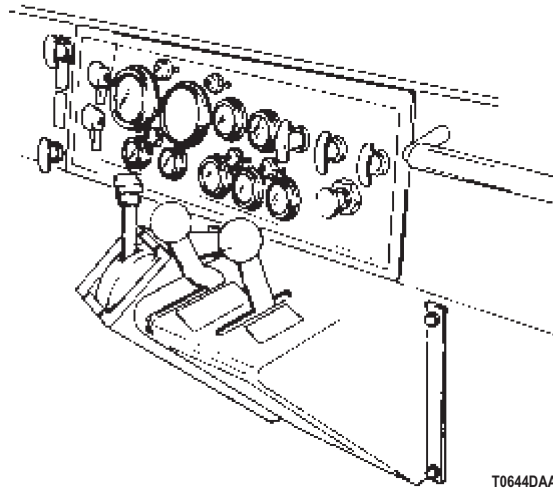

Figure 1. Power Takeoff Controls.

CONDITION/INDICATION

DOES POWER TAKEOFF ENGAGE?

DECISION

YES - Go to Step (2).

NO - Notify supervisor. Action may not be possible at this level of maintenance.

DUMP BODY WILL NOT RAISE - Continued**STEP**

2. ARE ALL HYDRAULIC LINES IN GOOD CONDITION?
 - a. Check all hydraulic lines for leaks and brakes. Refer to point to point schematics.

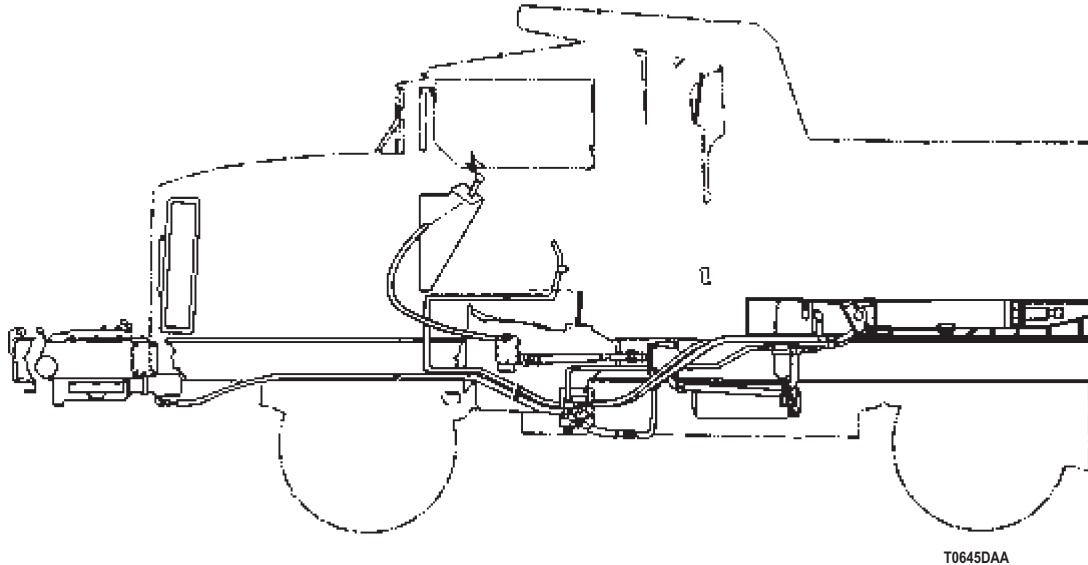

Figure 2. Hydraulic Lines.

- b. Tighten loose fittings.

CONDITION/INDICATION

ARE ALL HYDRAULIC LINES IN GOOD CONDITION?

DECISION

YES - Go to Step (3).

NO - Replace leaking or damaged hoses (Volume 4, WP 0715). Go to Step (6) to verify problem is solved.

DUMP BODY WILL NOT RAISE - Continued**STEP**

3. IS CONTROL VALVE IN GOOD CONDITION?
 - a. Visually check control valve for leaks and damage.

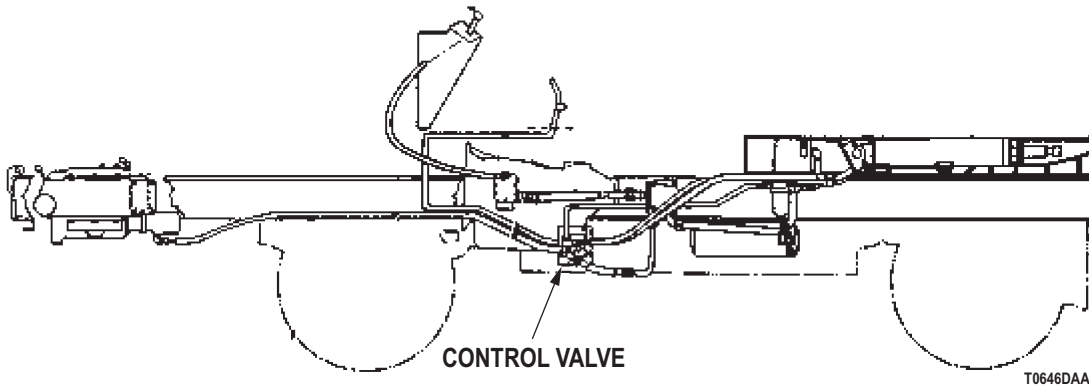

Figure 3. Control Valve.

- b. Tighten loose fittings.

CONDITION/INDICATION

IS CONTROL VALVE IN GOOD CONDITION?

DECISION

YES - Go to Step (4).

NO - Replace dump body control valve (Volume 4, WP 0720). Go to Step (6) to verify problem is solved.

STEP

4. DOES CONTROL VALVE SHAFT MOVE IN AND OUT?
 - a. Locate control valve.

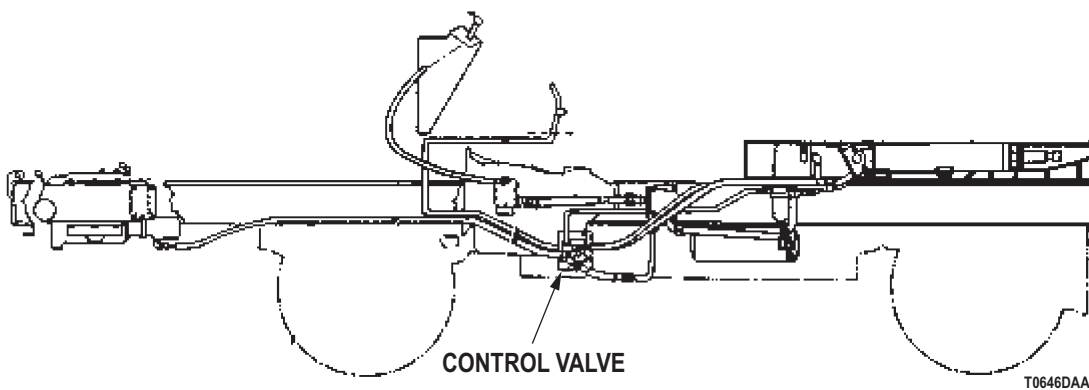

Figure 4. Control Valve Movement.

- b. Check for in and out movement of control valve shaft.

DUMP BODY WILL NOT RAISE - Continued**CONDITION/INDICATION**

DOES CONTROL VALVE SHAFT MOVE IN AND OUT?

DECISION

YES - Go to Step (5).

NO - Replace dump body control valve (Volume 4, WP 0720). Go to Step (6) to verify problem is solved.

STEP

5. ARE THERE LEAKS OR OVERHEATING OF PUMP HOUSING WITH POWER TAKEOFF ENGAGED?
 - a. Visually inspect pump housing for leaks and overheating.

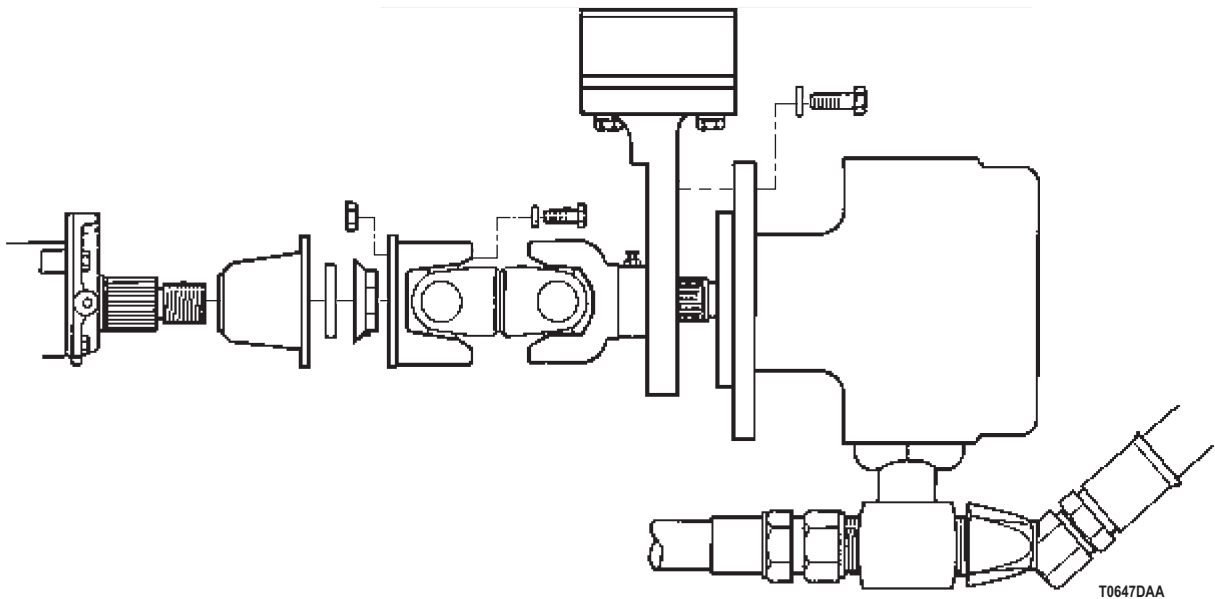

Figure 5. Pump Housing.

- b. Tighten any loose fittings.

CONDITION/INDICATION

ARE THERE LEAKS OR OVERHEATING OF PUMP HOUSING WITH POWER TAKEOFF ENGAGED?

DECISION

YES - Replace dump hydraulic pump (Volume 4, WP 0719). Go to Step (6) to verify problem is solved.

NO - Go to Step (6) to verify problem is solved.

DUMP BODY WILL NOT RAISE - Continued**STEP**

6. IS YOUR ORIGINAL DUMP BODY PROBLEM STILL PRESENT?
 - a. Ensure vehicle is returned to normal operating condition.
 - b. Check to see if your original dump body problem exists.

CONDITION/INDICATION

IS YOUR ORIGINAL DUMP BODY PROBLEM STILL PRESENT?

DECISION

YES - Notify supervisor.
NO - Problem fixed.

END OF WORK PACKAGE

**FIELD MAINTENANCE
DUMP BODY WILL NOT LOWER**

INITIAL SETUP:**Tools and Special Tools**

Tool Kit, General Mechanic's: Automotive
(Volume 5, WP 0826, Table 1, Item 56)
Test Set, Electronic Systems
(Volume 5, WP 0826, Table 1, Item 51)

Personnel Required

(2)

References

Point to Point Schematics

References (cont.)

TM 9-2320-272-10
Volume 4, WP 0720

Equipment Condition

Vehicle parked and engine shut down.
(TM 9-2320-272-10)

TROUBLESHOOTING PROCEDURE**DUMP BODY WILL NOT LOWER****NOTE**

Conducting these malfunction tests if dump body does not lower. This procedure will check for incorrect brace positioning and control valve shaft movement.

DUMP BODY WILL NOT LOWER - Continued**STEP****1. ARE BRACES UNDER DUMP BODY IN RAISED POSITION?**

Check for braces in raised position under dump body.

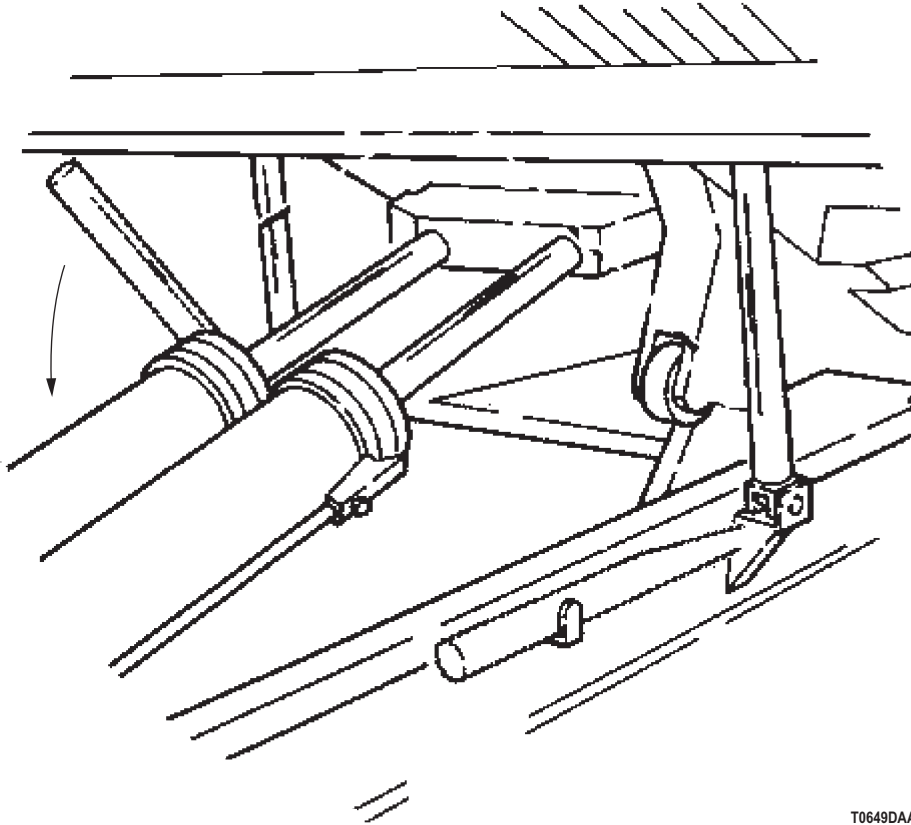

Figure 1. Dump Body Brace.

CONDITION/INDICATION

ARE BRACES UNDER DUMP BODY IN RAISED POSITION?

DECISION

YES - Lower and stow braces (TM 9-2320-272-10). Go to Step (3) to verify problem is solved.
NO - Go to Step (2).

STEP**2. DOES CONTROL VALVE SHAFT MOVE IN AND OUT?**

- a. Locate valve. Refer to point to point schematics.

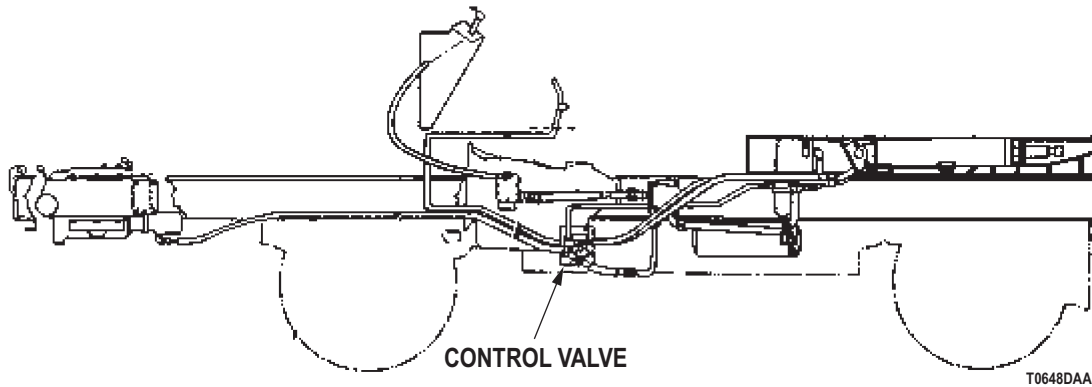
DUMP BODY WILL NOT LOWER - Continued*Figure 2. Control Valve.*

- b. Check for control valve shaft in and out movement.

CONDITION/INDICATION

DOES CONTROL VALVE SHAFT MOVE IN AND OUT?

DECISION

YES - Go to Step (3) to verify problem is solved.

NO - Replace dump control valve (Volume 4, WP 0720). Go to Step (3) to verify problem is solved.

STEP

3. IS YOUR ORIGINAL DUMP BODY LOWERING PROBLEM STILL PRESENT?
 - a. Ensure vehicle is returned to normal operating condition.
 - b. Check to see if your original dump body lowering problem still exists.

CONDITION/INDICATION

IS YOUR ORIGINAL DUMP BODY LOWERING PROBLEM STILL PRESENT?

DECISION

YES - Notify supervisor.

NO - Problem fixed.

END OF WORK PACKAGE

FIELD MAINTENANCE
DUMP BODY WILL NOT HOLD IN RAISED POSITION

INITIAL SETUP:**Tools and Special Tools**

Tool Kit, General Mechanic's: Automotive
(Volume 5, WP 0826, Table 1, Item 56)
Test Set, Electronic Systems
(Volume 5, WP 0826, Table 1, Item 51)

Personnel Required

(2)

References

Point to Point Schematics

References (cont.)

Volume 4, WP 0719
Volume 4, WP 0720

Equipment Condition

Vehicle parked and engine shut down.
(TM 9-2320-272-10)

TROUBLESHOOTING PROCEDURE**DUMP BODY WILL NOT HOLD IN RAISED POSITION****NOTE**

Conduct these malfunction tests if the dump body will not hold in raised position. This procedure will check for damaged hydraulic hoses and faulty control valve.

DUMP BODY WILL NOT HOLD IN RAISED POSITION - Continued**STEP**

1. ARE ALL HYDRAULIC LINES IN GOOD OPERATING CONDITION?
 - a. Visually check all hydraulic lines for breaks and leaks. Refer to point to point schematics.

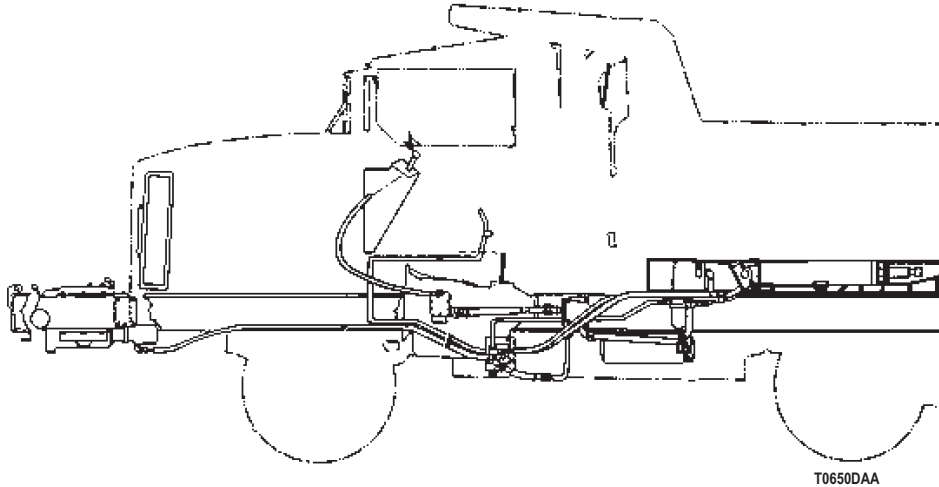

Figure 1. Hydraulic Lines.

- b. Tighten loose fittings.

CONDITION/INDICATION

ARE ALL HYDRAULIC LINES IN GOOD OPERATING CONDITION?

DECISION

YES - Go to Step (2).

NO - Replace damaged hydraulic lines (Volume 4, WP 0715). Go to Step (3) to verify problem is solved.

STEP

2. IS CONTROL VALVE IN GOOD OPERATING CONDITION?
 - a. Visually inspect control valve for hydraulic oil leaks.

DUMP BODY WILL NOT HOLD IN RAISED POSITION - Continued

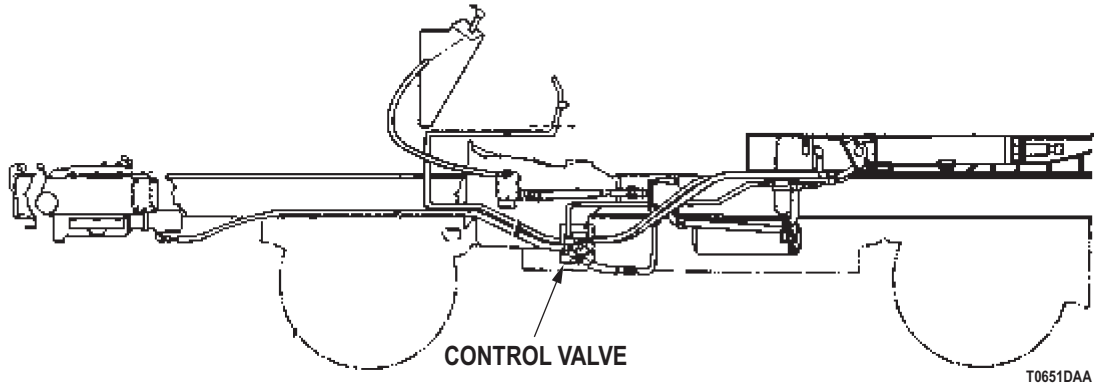

Figure 2. Control Valve.

- b. Tighten loose fitting.

CONDITION/INDICATION

IS CONTROL VALVE IN GOOD OPERATING CONDITION?

DECISION

- YES - Go to Step (3) to verify problem is solved.
- NO - Replace damaged or leaking valve (Volume 4, WP 0720). Go to Step (3) to verify problem is solved.

STEP

- 3. IS YOUR ORIGINAL DUMP BODY PROBLEM STILL PRESENT?
 - a. Ensure vehicle is returned to normal operating condition.
 - b. Check to see if your original dump body problem exists.

CONDITION/INDICATION

IS YOUR ORIGINAL DUMP BODY PROBLEM STILL PRESENT?

DECISION

- YES - Notify supervisor.
- NO - Problem fixed.

END OF WORK PACKAGE

**FIELD MAINTENANCE
DUMP HYDRAULIC PUMP NOISY**

INITIAL SETUP:**Tools and Special Tools**

Tool Kit, General Mechanic's: Automotive
(Volume 5, WP 0826, Table 1, Item 56)

Equipment Condition

Vehicle parked and engine shut down.
(TM 9-2320-272-10)

Personnel Required

(2)

References

Point to Point Schematics
Volume 5, WP 0820

TROUBLESHOOTING PROCEDURE**DUMP HYDRAULIC PUMP NOISY****NOTE**

Conduct this malfunction test if hydraulic pump is noisy. This procedure will check for hydraulic oil level.

DUMP HYDRAULIC PUMP NOISY - Continued**STEP****1. IS HYDRAULIC OIL AT PROPER LEVEL?**

Check reservoir for proper level.

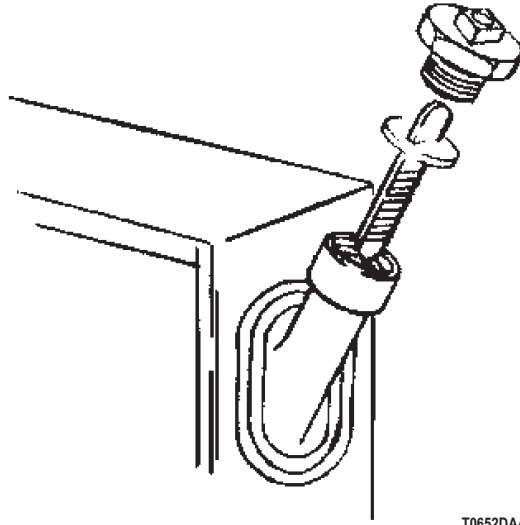

Figure 1. Hydraulic Oil Level.

CONDITION/INDICATION

IS HYDRAULIC OIL AT PROPER LEVEL?

DECISION

YES - Go to Step (2) to verify problem is solved.

NO - Fill reservoir to proper level (Volume 5, WP 0820). Go to Step (2) to verify problem is solved.

STEP**2. IS YOUR ORIGINAL HYDRAULIC PUMP PROBLEM STILL PRESENT?**

- a. Ensure vehicle is returned to normal operating condition.
- b. Check to see if your original hydraulic pump problem still exists.

CONDITION/INDICATION

IS YOUR ORIGINAL HYDRAULIC PUMP PROBLEM STILL PRESENT?

DECISION

YES - Notify supervisor.

NO - Problem fixed.

END OF WORK PACKAGE

**FIELD MAINTENANCE
TAILGATE WILL NOT OPEN**

INITIAL SETUP:**Tools and Special Tools**

Tool Kit, General Mechanic's: Automotive
(Volume 5, WP 0826, Table 1, Item 56)

References

Volume 4, WP 0591

Personnel Required

(2)

Equipment Condition

Vehicle parked and engine shut down.
(TM 9-2320-272-10)

TROUBLESHOOTING PROCEDURE**TAILGATE WILL NOT OPEN****NOTE**

Conduct these malfunction tests if tailgate does not open. This procedure will check for bent or broken tailgate linkage.

TAILGATE WILL NOT OPEN - Continued**STEP****1. ARE TAILGATE LINKAGE COMPONENT IN GOOD OPERATING CONDITION?**

Visually check tailgate for bent or broken components.

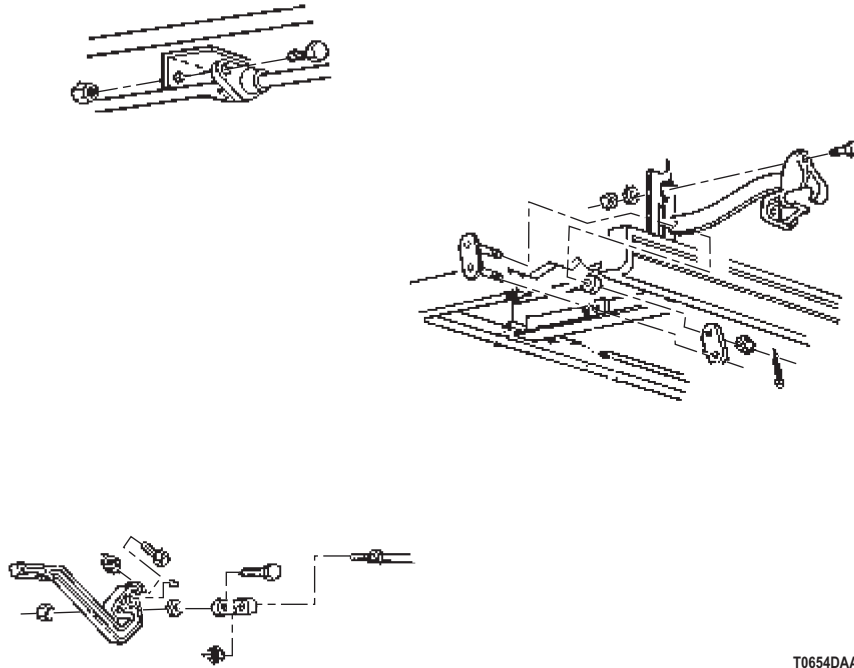

Figure 1. Tailgate Linkage.

CONDITION/INDICATION

ARE TAILGATE LINKAGE COMPONENT IN GOOD OPERATING CONDITION?

DECISION

YES - Go to Step (2) to verify problem is solved.

NO - Replace bent or broken linkage (Volume 4, WP 0591). Go to Step (2) to verify problem is solved.

TAILGATE WILL NOT OPEN - Continued**STEP**

2. IS YOUR ORIGINAL TAILGATE PROBLEM STILL PRESENT?
 - a. Ensure vehicle is returned to normal operating condition.
 - b. Check to see if your original tailgate problem exists.

CONDITION/INDICATION

IS YOUR ORIGINAL TAILGATE PROBLEM STILL PRESENT?

DECISION

YES - Notify supervisor.
NO - Problem fixed.

END OF WORK PACKAGE

**FIELD MAINTENANCE
SIDE PANELS HARD TO RETRACT OR EXPAND**

INITIAL SETUP:**Tools and Special Tools**

Tool Kit, General Mechanic's: Automotive
(Volume 5, WP 0826, Table 1, Item 56)

References

Volume 5, WP 0820

Personnel Required

(2)

Equipment Condition

Vehicle parked and engine shut down.
(TM 9-2320-272-10)

TROUBLESHOOTING PROCEDURE**SIDE PANELS HARD TO RETRACT OR EXPAND****NOTE**

Conduct these malfunction test if side panels are hard to retract. This procedure will check for improper lubrication of sprocket assembly and damage or dirt contamination of rollers.

SIDE PANELS HARD TO RETRACT OR EXPAND - Continued**STEP****1. IS SPROCKET ASSEMBLY CLEAN AND PROPERLY LUBRICATED?**

Visually inspect sprocket assembly for dirt or foreign material contamination.

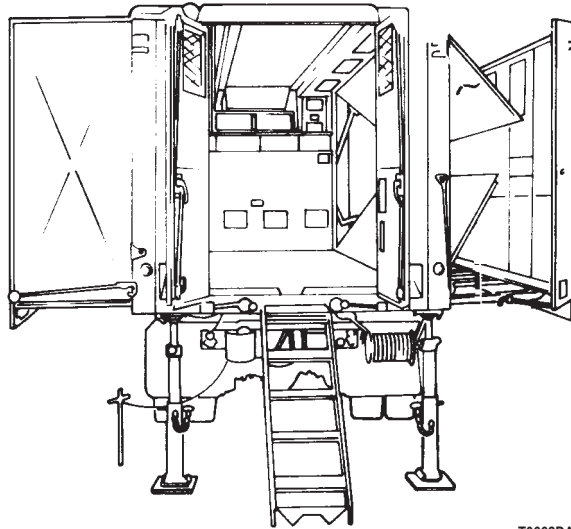

T0662DAA

Figure 1. Sprocket Assembly.

CONDITION/INDICATION

IS SPROCKET ASSEMBLY CLEAN AND PROPERLY LUBRICATED?

DECISION

YES - Go to Step (2).

NO - Clean and lubricate sprocket assembly (Volume 5, WP 0820). Go to Step (3) to verify problem is solved.

SIDE PANELS HARD TO RETRACT OR EXPAND - Continued**STEP**

2. ARE ROLLERS IN GOOD OPERATING CONDITION?
 - a. Visually check rollers for damage or dirt contamination.

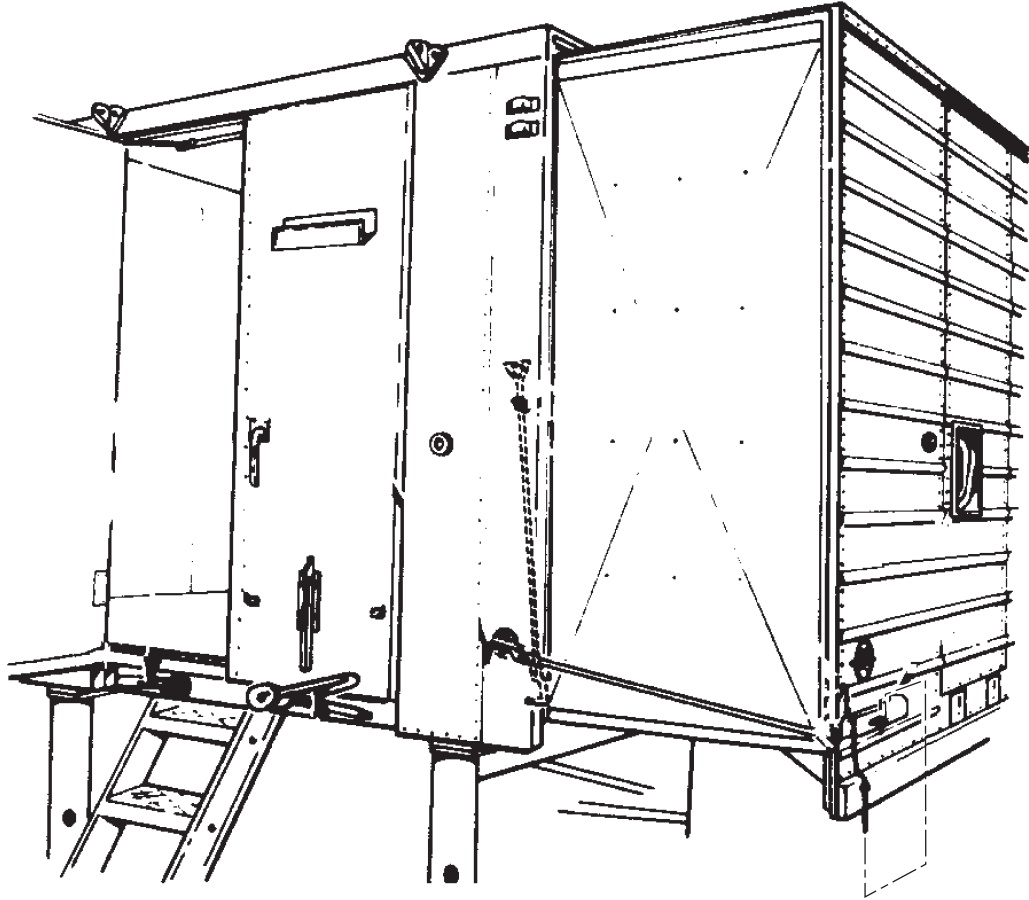

T0661DAA

Figure 2. Rollers.

- b. If dirt contamination is detected, clean dirt from rollers.

CONDITION/INDICATION

ARE ROLLERS IN GOOD OPERATING CONDITION?

DECISION

YES - Go to Step (3) to verify problem is solved.
NO - Notify supervisor. Action may not be possible at this level of maintenance.

SIDE PANELS HARD TO RETRACT OR EXPAND - Continued**STEP**

3. IS YOUR ORIGINAL SIDE PANEL PROBLEM STILL PRESENT?
 - a. Ensure vehicle is returned to normal operating condition.
 - b. Check to see if your original side panel problem still exists.

CONDITION/INDICATION

IS YOUR ORIGINAL SIDE PANEL PROBLEM STILL PRESENT?

DECISION

YES - Notify supervisor.
NO - Problem fixed.

END OF WORK PACKAGE

FIELD MAINTENANCE
SIDE PANEL CANNOT BE LOCKED IN RETRACT POSITION

INITIAL SETUP:**Tools and Special Tools**

Tool Kit, General Mechanic's: Automotive
(Volume 5, WP 0826, Table 1, Item 56)

Equipment Condition

Vehicle parked and engine shut down.
(TM 9-2320-272-10)

Personnel Required

(2)

TROUBLESHOOTING PROCEDURE**SIDE PANEL CANNOT BE LOCKED IN RETRACT POSITION****NOTE**

Conduct these malfunction tests if side panels cannot be locked in retracted position. This procedure will check if panels align properly.

SIDE PANEL CANNOT BE LOCKED IN RETRACT POSITION - Continued**STEP**

1. IS SIDE PANEL FULLY RETRACTED?
 - a. Visually check for front edge of panel to be fully retracted.

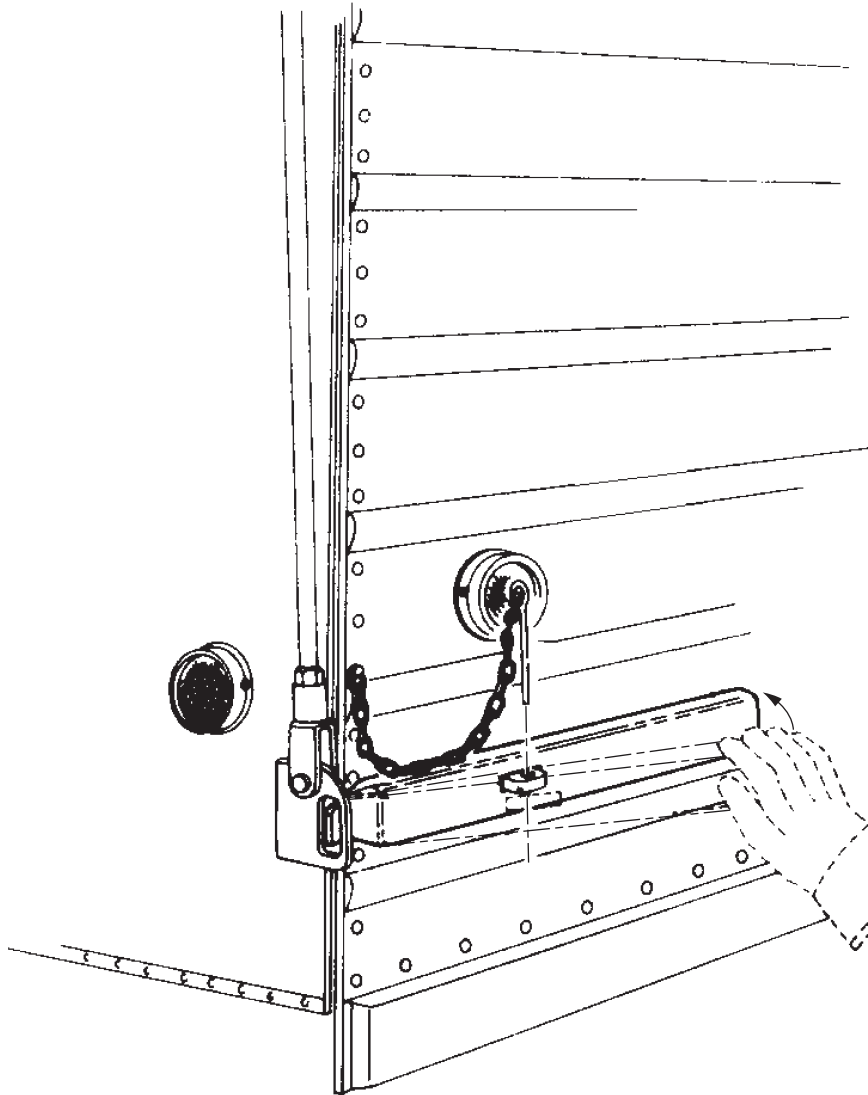

T0658DAA

Figure 1. Side Panel.

- b. If side panel front edge is not fully retracted, place heavy block of wood (2x4 or 4x4) against rub rail at front of panel.
- c. Strike block with heavy hammer.

SIDE PANEL CANNOT BE LOCKED IN RETRACT POSITION - Continued**CONDITION/INDICATION**

IS SIDE PANEL FULLY RETRACTED?

DECISION

YES - Go to Step (2).

NO - Notify supervisor. Action may not be possible at this level of maintenance.

STEP

2. IS TOP OF SIDE PANEL CLOSE ENOUGH TO ROOF EDGE IN ORDER TO ENGAGE?
 - a. Visually check if top of side panel is too far out to engage edge of roof.

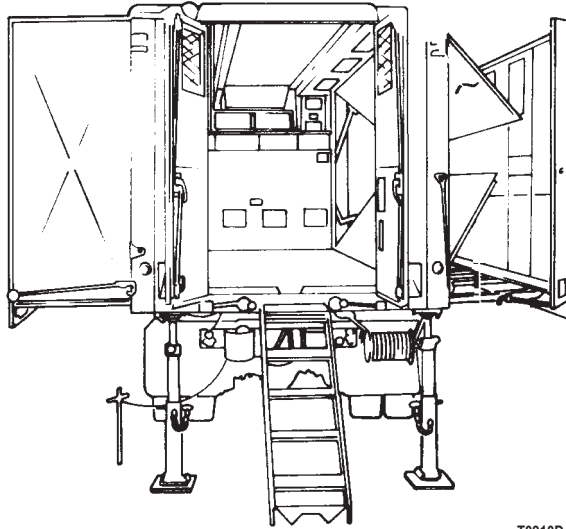

T0910DAA

Figure 2. Roof Edge.

- b. If top of side panel is too far out to engage edge of roof, place heavy block of wood against flat surface of seal retainer opposite locking bar at top of side panel.
 - c. Strike block with heavy hammer.

CONDITION/INDICATION

IS TOP OF SIDE PANEL CLOSE ENOUGH TO ROOF EDGE IN ORDER TO ENGAGE?

DECISION

YES - Go to Step (3) to verify problem is solved.

NO - Notify supervisor. Action may not be possible at this level of maintenance.

SIDE PANEL CANNOT BE LOCKED IN RETRACT POSITION - Continued**STEP**

3. IS YOUR ORIGINAL SIDE PANEL PROBLEM STILL PRESENT?
 - a. Ensure vehicle is returned to normal operating condition.
 - b. Check to see if your original side panel problem still exists.

CONDITION/INDICATION

IS YOUR ORIGINAL SIDE PANEL PROBLEM STILL PRESENT?

DECISION

YES - Notify supervisor.
NO - Problem fixed.

END OF WORK PACKAGE

FIELD MAINTENANCE
VAN BODY NOT WATERPROOF OR LIGHT TIGHT

INITIAL SETUP:**Tools and Special Tools**

Tool Kit, General Mechanic's: Automotive
(Volume 5, WP 0826, Table 1, Item 56)

References

Volume 4, WP 0614

Personnel Required

(2)

Equipment Condition

Vehicle parked and engine shut down.
(TM 9-2320-272-10)

TROUBLESHOOTING PROCEDURE**VAN BODY NOT WATERPROOF OR LIGHT TIGHT****NOTE**

Conduct these malfunction tests if van body is not waterproof or light tight. This procedure will check for tight fit of side panels to van body, sagging end panel and seal for improper position or worn out condition.

VAN BODY NOT WATERPROOF OR LIGHT TIGHT - Continued**STEP**

1. IS LOWER PART OF SIDE PANEL PROPERLY POSITIONED?
 - a. Visually inspect lower part of panel for tightness against van body.

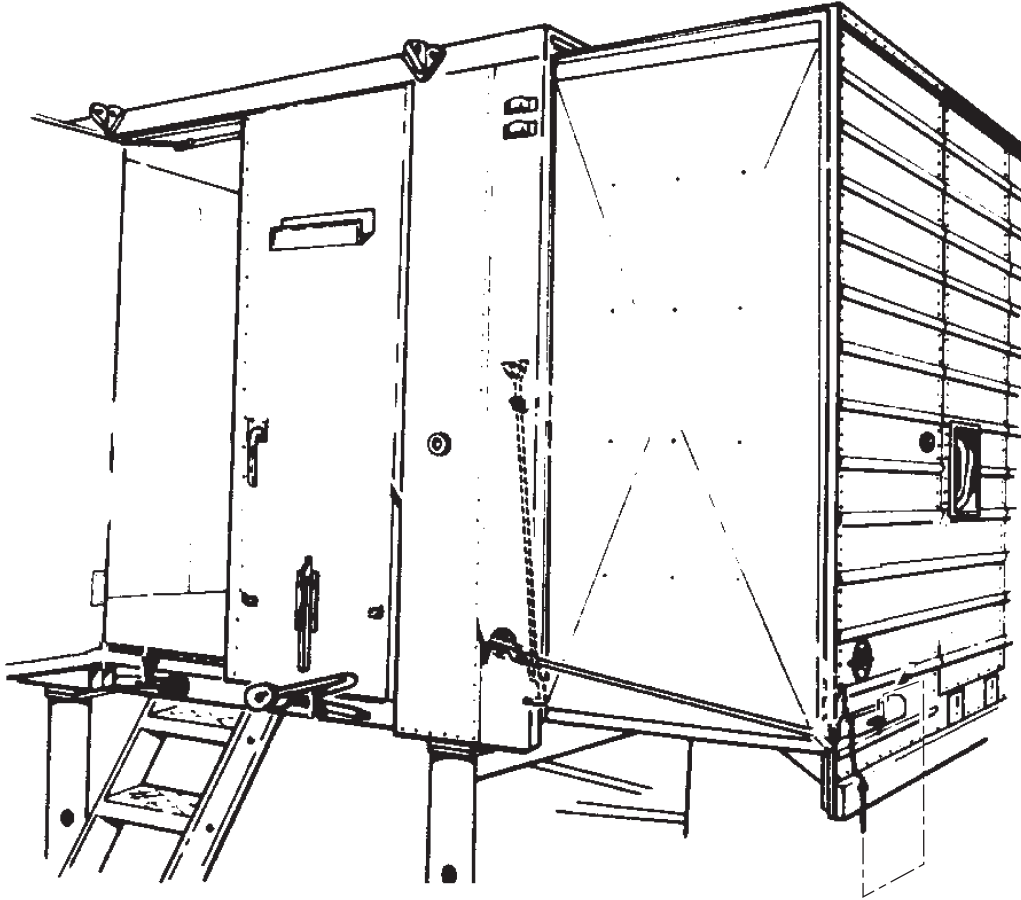

Figure 1. Side Panel.

- b. If leak is detected, place heavy block of wood against rub rail at end side of panel where leak occurs.
- c. Strike block with heavy hammer.

CONDITION/INDICATION

IS LOWER PART OF SIDE PANEL PROPERLY POSITIONED?

DECISION

YES - Go to Step (2).

NO - Notify supervisor. Action may not be possible at this level of maintenance.

VAN BODY NOT WATERPROOF OR LIGHT TIGHT - Continued**STEP**

2. IS END PANEL PROPERLY POSITIONED?
 - a. Visually check end panel for sagging.

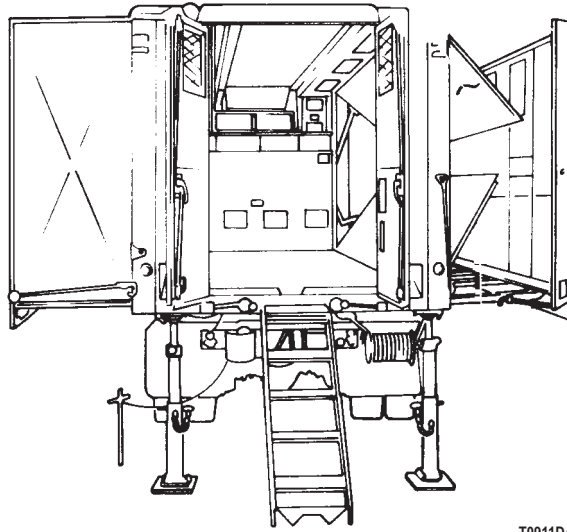

T0911DAA

Figure 2. End Panel.

- b. If leak is detected, place heavy block of wood against rub rail at end side of panel where leak occurs.
 - c. Strike block with heavy hammer.

CONDITION/INDICATION

IS END PANEL PROPERLY POSITIONED?

DECISION

YES - Go to Step (3).

NO - Notify supervisor. Action may not be possible at this level of maintenance.

VAN BODY NOT WATERPROOF OR LIGHT TIGHT - Continued**STEP****3. IS BLOCK SEAL OUT OF POSITION?**

- a. Visually check if lip of block seal at inner rear corner of hinged roof is out of position.

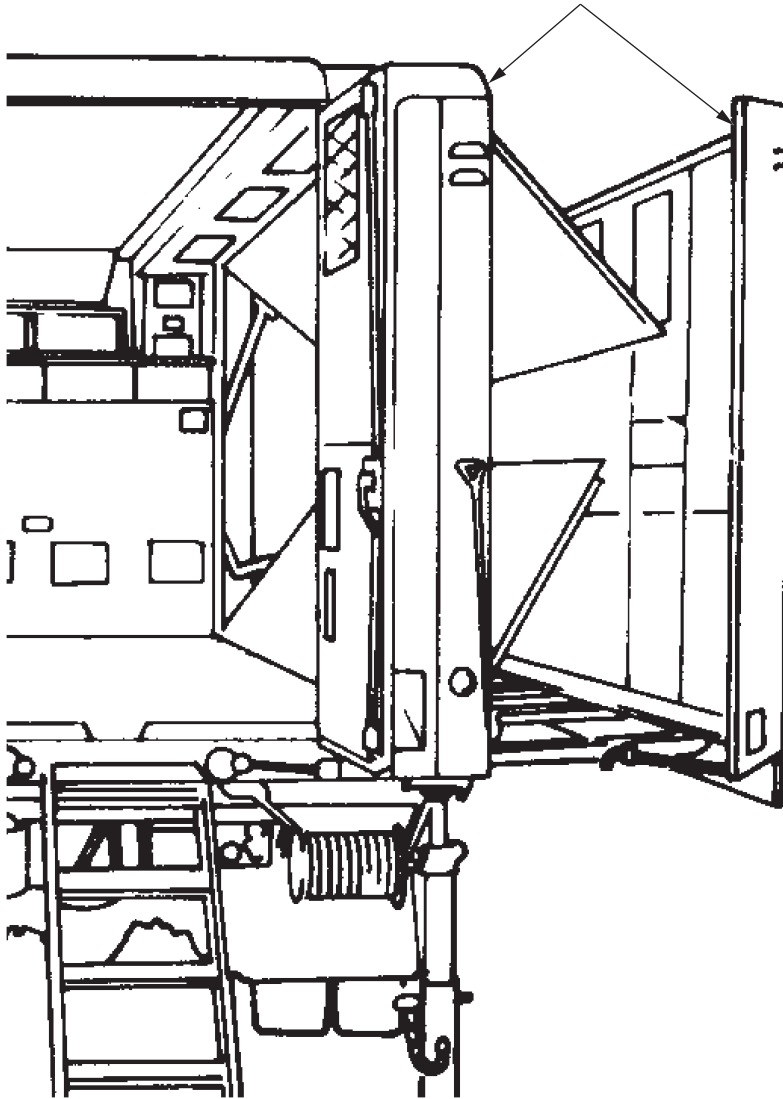

T0659DAA

Figure 3. Block Seal.

- b. If seal is out of position, move side panel out to disengage corner block seal.
- c. Push seal lip up into correct position.
- d. Retract side panel and check if end panel door properly engages seal.

CONDITION/INDICATION

IS BLOCK SEAL OUT OF POSITION?

VAN BODY NOT WATERPROOF OR LIGHT TIGHT - Continued**DECISION**

YES - Notify supervisor. Action may not be possible at this level of maintenance.
NO - Go to Step (4).

STEP**4. IS REAR DOOR SEAL IN GOOD CONDITION?**

Visually check for worn or loose seal at top of rear doors.

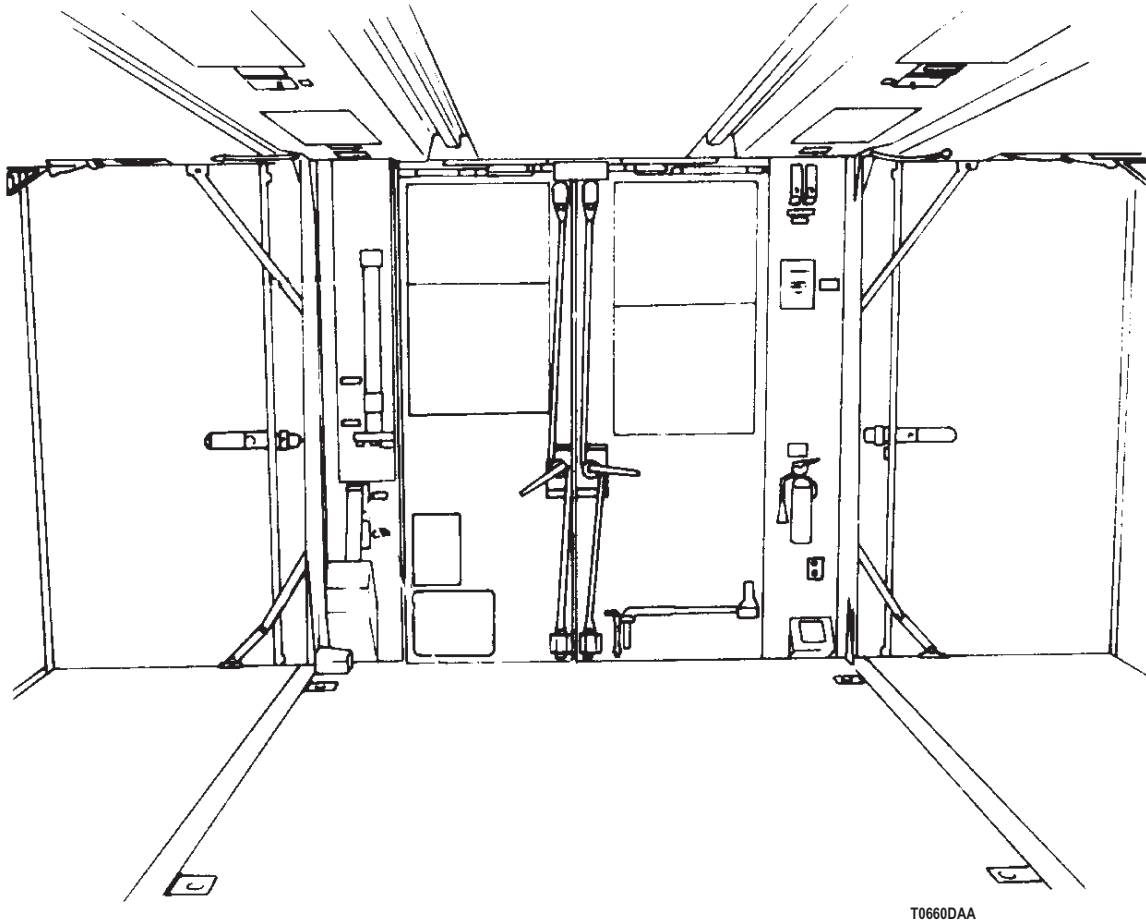

T0660DAA

Figure 4. Rear Door Seal.

CONDITION/INDICATION

IS REAR DOOR SEAL IN GOOD CONDITION?

DECISION

YES - Go to Step (5) to verify problem is solved.
NO - Replace rear door seal (Volume 4, WP 0614). Go to Step (5) to verify problem is solved.

VAN BODY NOT WATERPROOF OR LIGHT TIGHT - Continued**STEP**

5. IS YOUR ORIGINAL PANEL FIT PROBLEM STILL PRESENT?
 - a. Ensure vehicle is returned to normal operating condition.
 - b. Check to see if your original panel fit problem still exists.

CONDITION/INDICATION

IS YOUR ORIGINAL PANEL FIT PROBLEM STILL PRESENT?

DECISION

YES - Notify supervisor.
NO - Problem fixed.

END OF WORK PACKAGE

**FIELD MAINTENANCE
DOOR LOCK WILL NOT OPERATE**

INITIAL SETUP:**Tools and Special Tools**

Tool Kit, General Mechanic's: Automotive
(Volume 5, WP 0826, Table 1, Item 56)

References

Volume 4, WP 0616

Personnel Required

(2)

Equipment Condition

Vehicle parked and engine shut down.
(TM 9-2320-272-10)

TROUBLESHOOTING PROCEDURE**DOOR LOCK WILL NOT OPERATE****NOTE**

Conduct these malfunction tests if door lock will not operate. This procedure will check for a jammed vertical bar, and alignment of vertical bar and striker plate.

DOOR LOCK WILL NOT OPERATE - Continued**STEP**

1. IS DOOR LOCK JAMMED?
 - a. Open door with faulty door lock.

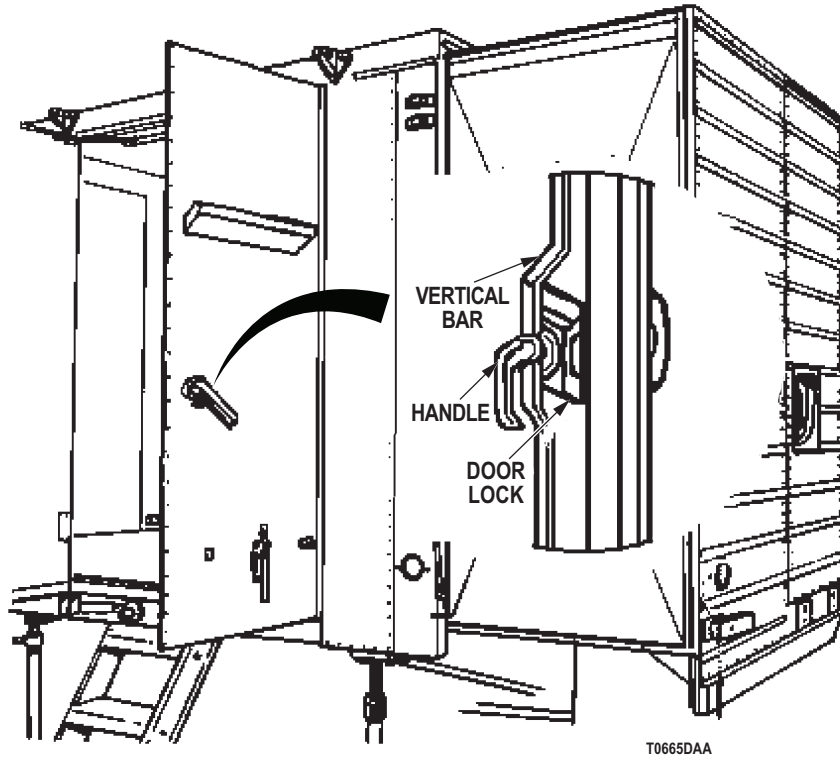

Figure 1. Door Lock.

- b. Turn door handle to see if vertical bar move freely.

CONDITION/INDICATION

IS DOOR LOCK JAMMED?

DECISION

YES - Disassemble and repair lock assembly (Volume 4, WP 0616). Go to Step (3) to verify problem is solved.
NO - Go to Step (2).

DOOR LOCK WILL NOT OPERATE - Continued**STEP****2. ARE VERTICAL BAR AND STRIKER PLATE ALIGNED?**

Slowly pull faulty door closed while watching alignment of vertical bar and striker plate.

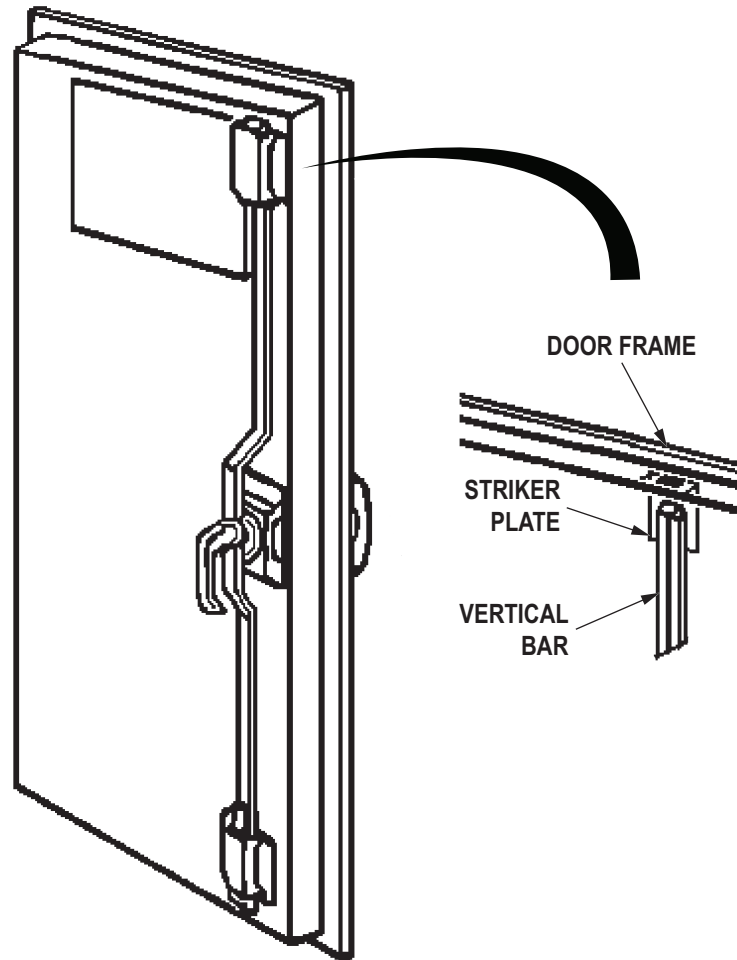

T0666DAA

Figure 2. Striker Plate.

CONDITION/INDICATION

ARE VERTICAL BAR AND STRIKER PLATE ALIGNED?

DECISION

YES - Add or remove shims behind lock until bolt properly engages striker plate (Volume 4, WP 0616). Go to Step (3) to verify problem is solved.

NO - Go to Step (3) to verify problem is solved.

DOOR LOCK WILL NOT OPERATE - Continued**STEP**

3. IS YOUR ORIGINAL PROBLEM STILL PRESENT?
 - a. Ensure vehicle is returned to normal operating condition.
 - b. Check to see if your original problem still exists.

CONDITION/INDICATION

IS YOUR ORIGINAL PROBLEM STILL PRESENT?

DECISION

YES - Notify supervisor.
NO - Problem fixed.

END OF WORK PACKAGE

**FIELD MAINTENANCE
ENGINE AND VEHICLE ELECTRICAL SYSTEMS MALFUNCTIONING**

INITIAL SETUP:**Tools and Special Tools**

Tool Kit, General Mechanic's: Automotive
(Volume 5, WP 0826, Table 1, Item 56)
Multimeter
(Volume 5, WP 0826, Table 1, Item 34)
Test Set, Electronic Systems
(Volume 5, WP 0826, Table 1, Item 51)

References (cont.)

WP 0089
Volume 2, WP 0319

Equipment Condition

Vehicle parked and engine shut down.
(TM 9-2320-272-10)

Personnel Required

(2)

References

Point to Point Schematics

TROUBLESHOOTING PROCEDURE**ENGINE AND VEHICLE ELECTRICAL SYSTEMS MALFUNCTIONING****NOTE**

Conduct these malfunction tests if engine and vehicle electrical systems are malfunctioning.
This procedure will check the protective control box function.

STEP

1. ARE VEHICLE GROUND STRAPS SECURELY FASTENED?
 - a. Ensure ground straps are securely fastened.
 - b. Ensure no paint is under starwashers.

CONDITION/INDICATION

ARE VEHICLE GROUND STRAPS SECURELY FASTENED?

DECISION

NO - Remove paint and secure ground strap. Go to Step (3) to verify problem is solved.
YES - Go to Step (2).

ENGINE AND VEHICLE ELECTRICAL SYSTEMS MALFUNCTIONING - Continued**STEP****2. IS PROTECTIVE CONTROL BOX FAULTY?**

Figure 1. Protective Control Box.

NOTE

If thug is heard when connector is disconnected, protective control box is faulty.

- a. Unplug harness connector from protective control box.
- b. Listen for protective control box to reset.

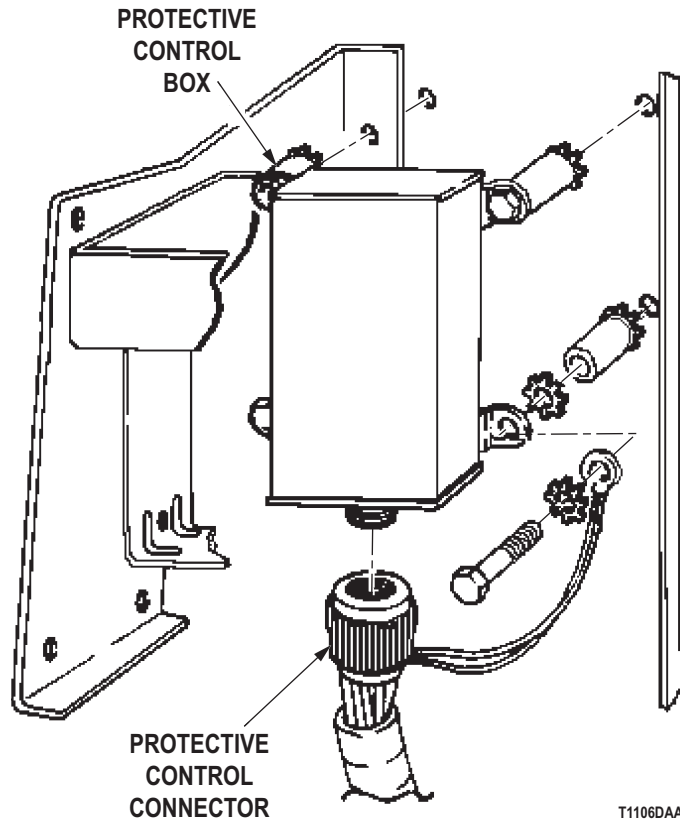
CONDITION/INDICATION

IS PROTECTIVE CONTROL BOX FAULTY?

DECISION

YES - Replace protective control box (Volume 2, WP 0319). Go to Step (3) to verify problem is solved.
NO - Perform No Or Low Alternator Output troubleshooting (WP 0089).

ENGINE AND VEHICLE ELECTRICAL SYSTEMS MALFUNCTIONING - Continued**STEP**

3. IS YOUR ORIGINAL PROBLEM STILL PRESENT?
 - a. Ensure vehicle is returned to normal operating condition.
 - b. Check to see if your original problem still exists.

CONDITION/INDICATION

IS YOUR ORIGINAL PROBLEM STILL PRESENT?

DECISION

YES - Notify supervisor.
NO - Problem fixed.

END OF WORK PACKAGE

FIELD MAINTENANCE
ENGINE WILL NOT CRANK; SOME ELECTRICAL SYSTEMS INOPERATIVE OR WEAK

INITIAL SETUP:**Tools and Special Tools**

Tool Kit, General Mechanic's: Automotive
(Volume 5, WP 0826, Table 1, Item 56)
Multimeter
(Volume 5, WP 0826, Table 1, Item 34)
Test Set, Electronic Systems
(Volume 5, WP 0826, Table 1, Item 51)

References (cont.)

TM 9-6140-200-14
Volume 2, WP 0346
Volume 2, WP 0349
Volume 2, WP 0350

Personnel Required

(2)

Equipment Condition

Vehicle parked and engine shut down.
(TM 9-2320-272-10)

References

Point to Point Schematics

TROUBLESHOOTING PROCEDURE**ENGINE WILL NOT CRANK; SOME ELECTRICAL SYSTEMS INOPERATIVE OR WEAK****NOTE**

Conduct these malfunction tests if some electrical systems are inoperative or weak. This procedure will check the battery terminals, posts, cases and cables as well as battery electrolyte levels, specific gravity and voltage.

ENGINE WILL NOT CRANK; SOME ELECTRICAL SYSTEMS INOPERATIVE OR WEAK - Continued**STEP**

1. ARE THE BATTERIES IN GOOD CONDITION?
 - a. Visually check batteries for cracks or leaks.

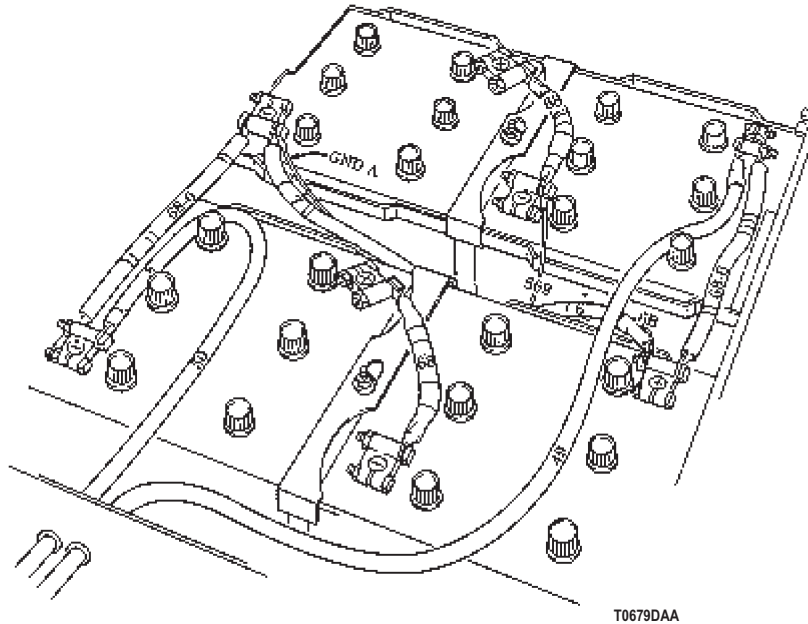

Figure 1. Batteries.

- b. Visually check batteries for loose or broken terminal posts. Clean corroded terminal posts to bright metal.

CONDITION/INDICATION

ARE THE BATTERIES IN GOOD CONDITION?

DECISION

NO - Replace faulty battery (Volume 2, WP 0346). Go to Step (6) to verify problem is solved.
YES - Go to Step (2).

ENGINE WILL NOT CRANK; SOME ELECTRICAL SYSTEMS INOPERATIVE OR WEAK - Continued**STEP****2. ARE BATTERY TERMINALS OR CABLES LOOSE, BROKEN, OR WORN?**

- a. Visually check batteries for loose, broken, or worn terminals. Refer to point to point schematics.

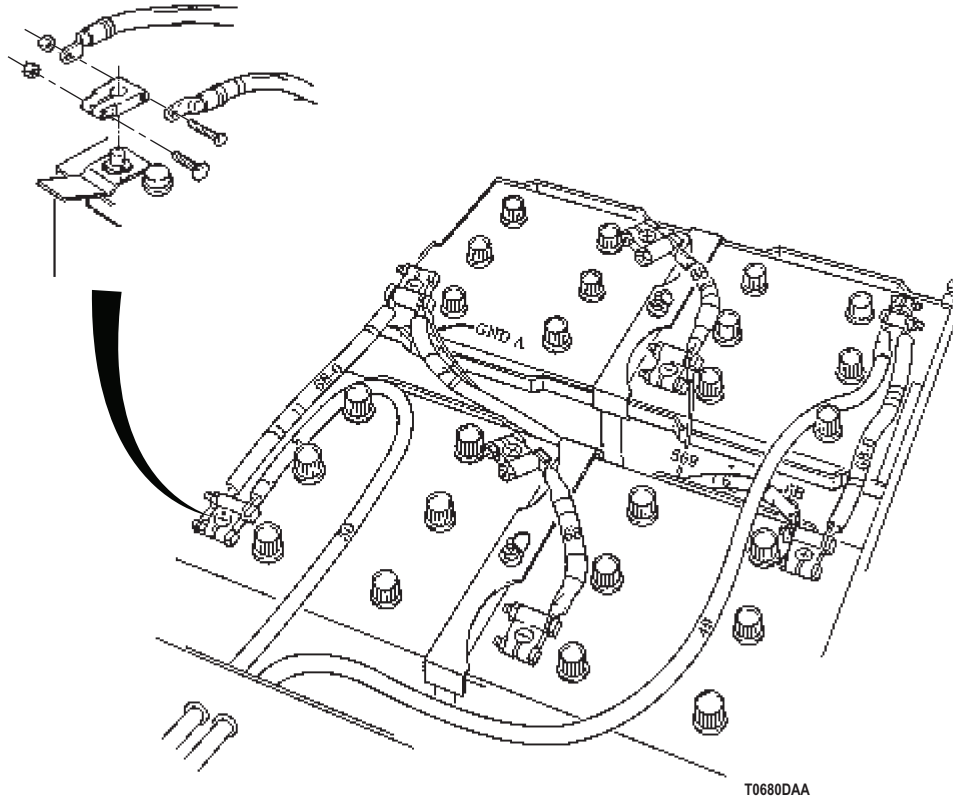

Figure 2. Battery Terminals.

- b. Visually check batteries for loose, broken, or worn cables.

CONDITION/INDICATION

ARE BATTERY TERMINALS OR CABLES LOOSE, BROKEN, OR WORN?

DECISION

YES - Battery terminals or cables loose, broken, or worn. Replace damaged terminals and cables (Volume 2, WP 0349). Go to Step (6) to verify problem is solved.

YES - Battery ground cables loose, broken, or worn. Replace damaged cables (Volume 2, WP 0350). Go to Step (6) to verify problem is solved.

NO - Go to Step (3).

ENGINE WILL NOT CRANK; SOME ELECTRICAL SYSTEMS INOPERATIVE OR WEAK - Continued**STEP****3. IS THE ELECTROLYTE IN EACH BATTERY CELL AT THE PROPER LEVEL?**

Check electrolyte level in each battery cell (TM 9-6140-200-14).

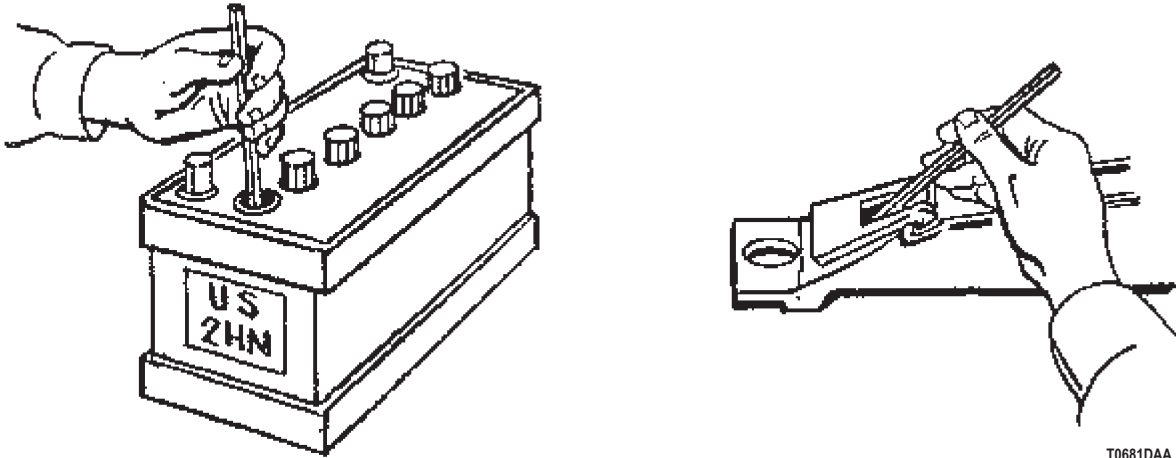

T0681DAA

Figure 3. Specific Gravity Test.

CONDITION/INDICATION

IS THE ELECTROLYTE IN EACH BATTERY CELL AT THE PROPER LEVEL?

DECISION

NO - Fill each cell to the fill ring with distilled water (TM 9-6140-200-14). Go to Step (4).

YES - Go to Step (4).

ENGINE WILL NOT CRANK; SOME ELECTRICAL SYSTEMS INOPERATIVE OR WEAK - Continued**STEP****4. ARE BATTERIES SPECIFIC GRAVITY READINGS CORRECT?**

- a. Perform a specific gravity test (TM 9-6140-200-14).

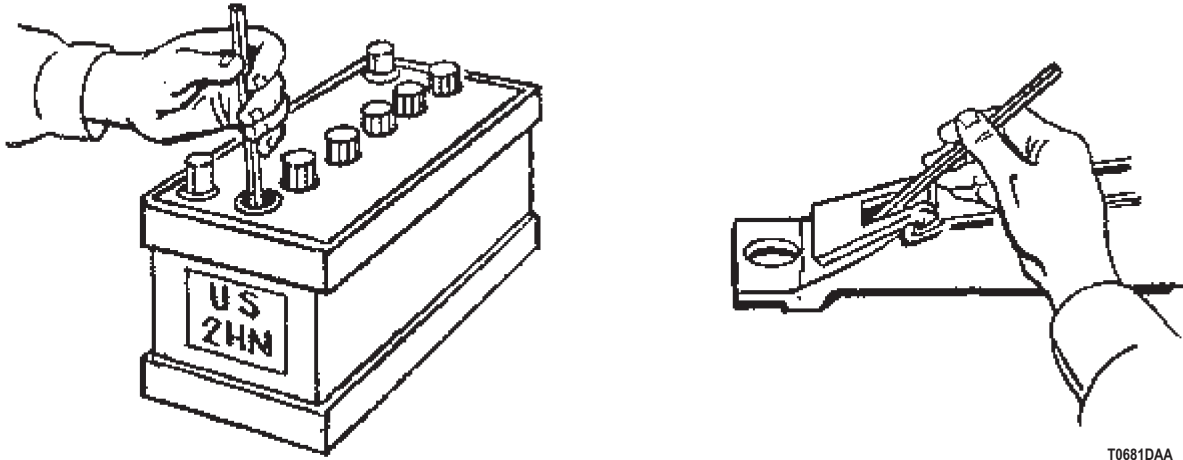

T0681DAA

Figure 4. Specific Gravity Test.

- b. Batteries must test 1.225 or greater, temperature corrected.
- c. Each cell in a battery must test within 25 points of the other cells.
- d. If any battery or batteries do not meet requirements, recharge as required (TM 9-6140-200-14).
- e. Perform specific gravity test again.

CONDITION/INDICATION

ARE BATTERIES SPECIFIC GRAVITY READINGS CORRECT?

DECISION

NO - Replace defective battery (Volume 2, WP 0346). Go to Step (6) to verify problem is solved.
 YES - Go to Step (5).

ENGINE WILL NOT CRANK; SOME ELECTRICAL SYSTEMS INOPERATIVE OR WEAK - Continued**STEP**

5. IS BATTERY VOLTAGE DROP 1 VOLT OR GREATER UNDER LOAD?
- a. Set up multimeter to measure VDC.

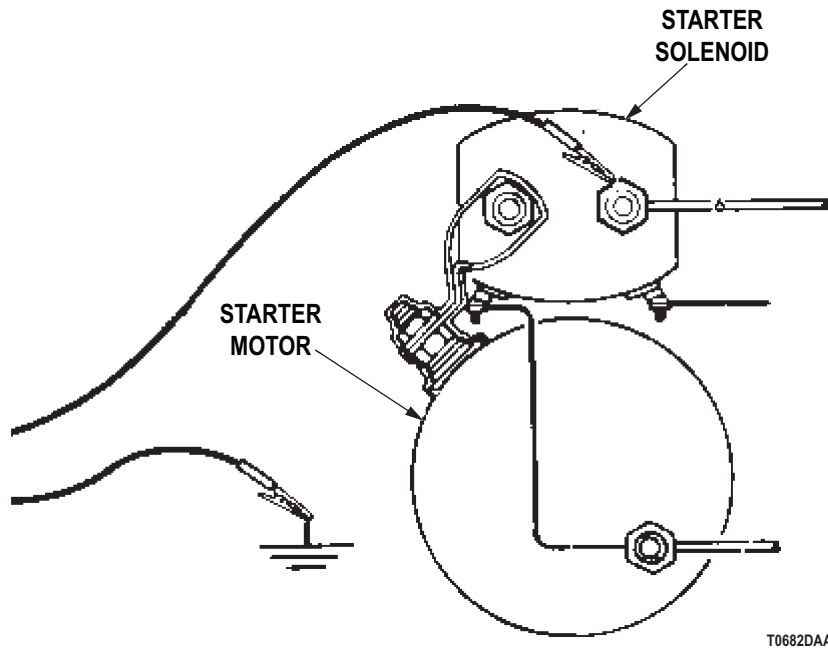

Figure 5. Battery/Solenoid Voltage Test.

- b. Connect multimeter red lead to starter, terminal 6. Refer to point to point schematics.
- c. Connect multimeter black lead to ground.
- d. Note meter reading.
- e. Turn headlight switch and battery switch to ON position for 15 seconds (headlights on bright).
- f. Voltage should not drop more than 1 volt.

CONDITION/INDICATION

IS BATTERY VOLTAGE DROP 1 VOLT OR GREATER UNDER LOAD?

DECISION

YES - Recharge batteries (Volume 2, WP 0346). Go to Step (6) to verify problem is solved.

NO - Notify supervisor. It is possible another troubleshooting work package applies.

ENGINE WILL NOT CRANK; SOME ELECTRICAL SYSTEMS INOPERATIVE OR WEAK - Continued**STEP**

6. IS YOUR ORIGINAL ELECTRICAL SYSTEMS PROBLEM STILL PRESENT?
 - a. Ensure vehicle is returned to normal operating condition.
 - b. Check to see if your original electrical systems problem still exists. Refer to point to point schematics.

CONDITION/INDICATION

IS YOUR ORIGINAL ELECTRICAL SYSTEMS PROBLEM STILL PRESENT?

DECISION

YES - Notify supervisor.
NO - Problem fixed.

END OF WORK PACKAGE

**FIELD MAINTENANCE
ALL VEHICLE ELECTRICAL SYSTEMS INOPERATIVE**

INITIAL SETUP:**Tools and Special Tools**

Tool Kit, General Mechanic's: Automotive
(Volume 5, WP 0826, Table 1, Item 56)
Multimeter
(Volume 5, WP 0826, Table 1, Item 34)
Test Set, Electronic Systems
(Volume 5, WP 0826, Table 1, Item 51)

References (cont.)

Volume 2, WP 0319
Volume 2, WP 0346
Volume 2, WP 0349
Volume 2, WP 0350

Personnel Required

(2)

Equipment Condition

Vehicle parked and engine shut down.
(TM 9-2320-272-10)

References

Point to Point Schematics

TROUBLESHOOTING PROCEDURE**ALL VEHICLE ELECTRICAL SYSTEMS INOPERATIVE****NOTE**

Conduct these malfunction tests if all vehicle electrical systems are inoperative. This procedure will check the battery cable connections, batteries, and the protective control box.

ALL VEHICLE ELECTRICAL SYSTEMS INOPERATIVE - Continued**STEP**

1. ARE BATTERIES CONNECTED PROPERLY?
 - a. Place battery switch to OFF position.
 - b. Verify batteries are properly connected. Refer to point to point schematics.

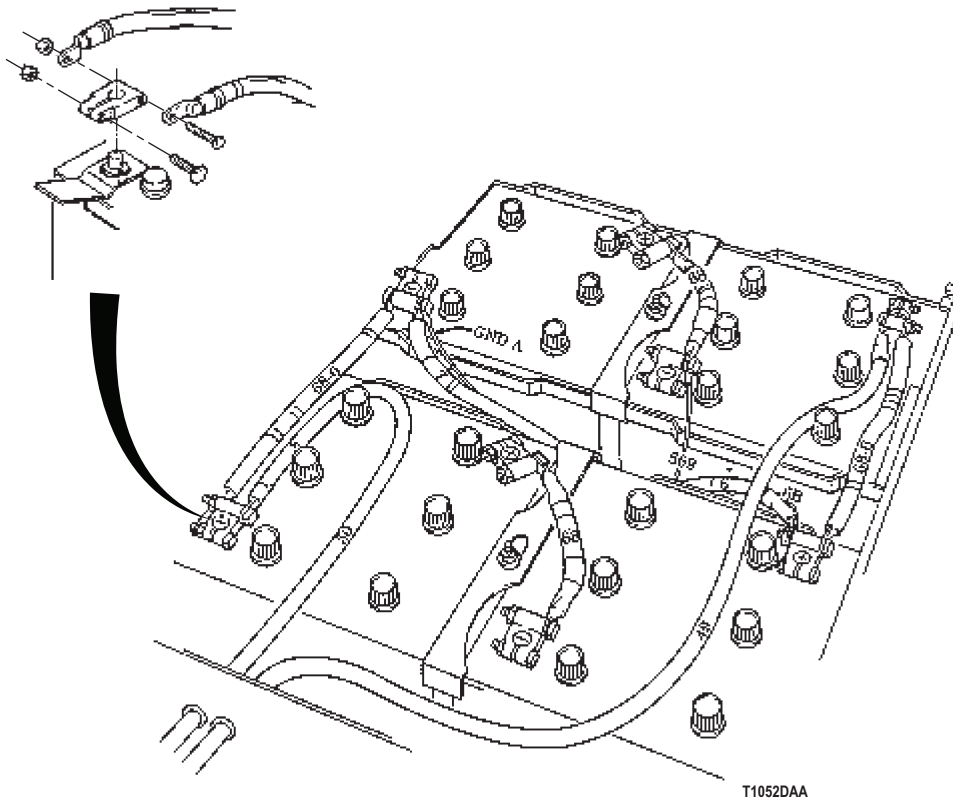

Figure 1. Battery Terminals.

CONDITION/INDICATION

ARE BATTERIES CONNECTED PROPERLY?

DECISION

YES - Go to Step (2).

NO - Connect batteries properly (Volume 2, WP 0346). Go to Step (7) to verify problem is solved.

ALL VEHICLE ELECTRICAL SYSTEMS INOPERATIVE - Continued**STEP****2. ARE THE BATTERIES IN GOOD CONDITION?**

Visually check batteries for cracks, leaks, and loose or broken terminal posts. Clean corroded terminal posts to bright metal (Volume 2, WP 0346).

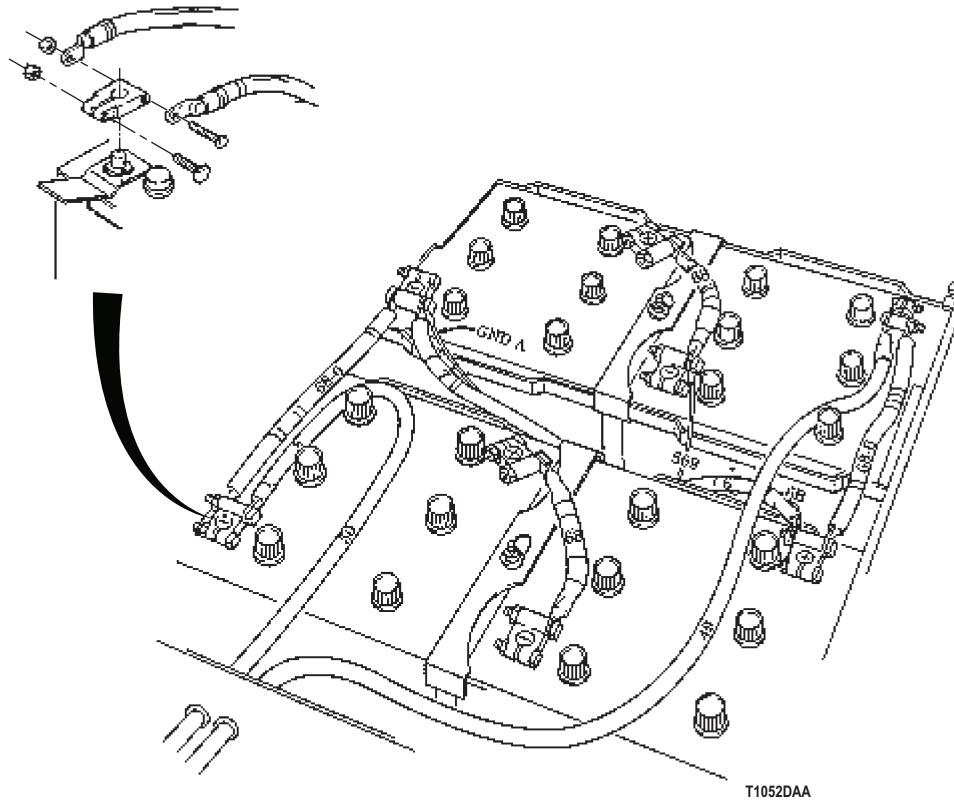

Figure 2. Battery Terminals.

CONDITION/INDICATION

ARE THE BATTERIES IN GOOD CONDITION?

DECISION

YES - Go to Step (3).

NO - Replace faulty battery (Volume 2, WP 0346). Go to Step (7) to verify problem is solved.

ALL VEHICLE ELECTRICAL SYSTEMS INOPERATIVE - Continued**STEP****3. ARE BATTERY TERMINALS OR CABLES LOOSE, BROKEN, OR WORN?**

Visually check batteries for loose, broken, or worn terminals and cables. Refer to point to point schematics.

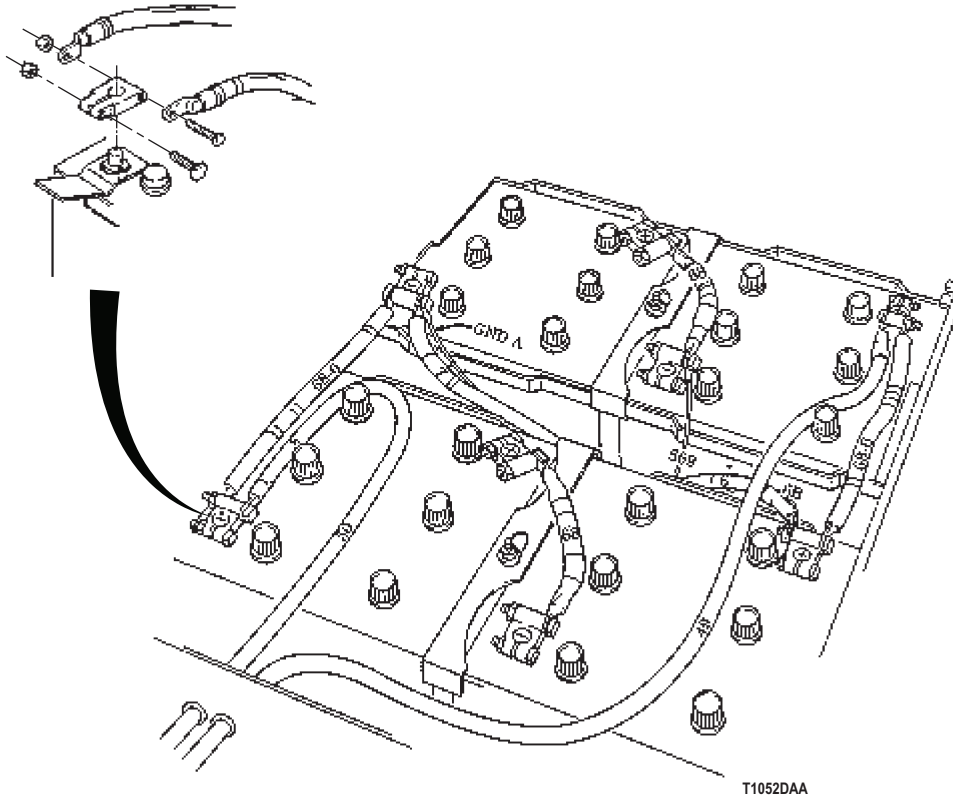

Figure 3. Battery Terminals.

CONDITION/INDICATION

ARE BATTERY TERMINALS OR CABLES LOOSE, BROKEN, OR WORN?

DECISION

YES - Battery terminals or cables loose, broken, or worn. Replace damaged terminals and cables (Volume 2, WP 0349). Go to Step (7) to verify problem is solved.

YES - Battery ground cables loose, broken, or worn. Replace damaged cables (Volume 2, WP 0350). Go to Step (7) to verify problem is solved.

NO - Go to Step (4).

ALL VEHICLE ELECTRICAL SYSTEMS INOPERATIVE - Continued**STEP**

4. IS THE ELECTROLYTE IN EACH BATTERY CELL AT THE PROPER LEVEL?
 - a. Check electrolyte level in each battery cell (TM 9-6140-200-14).

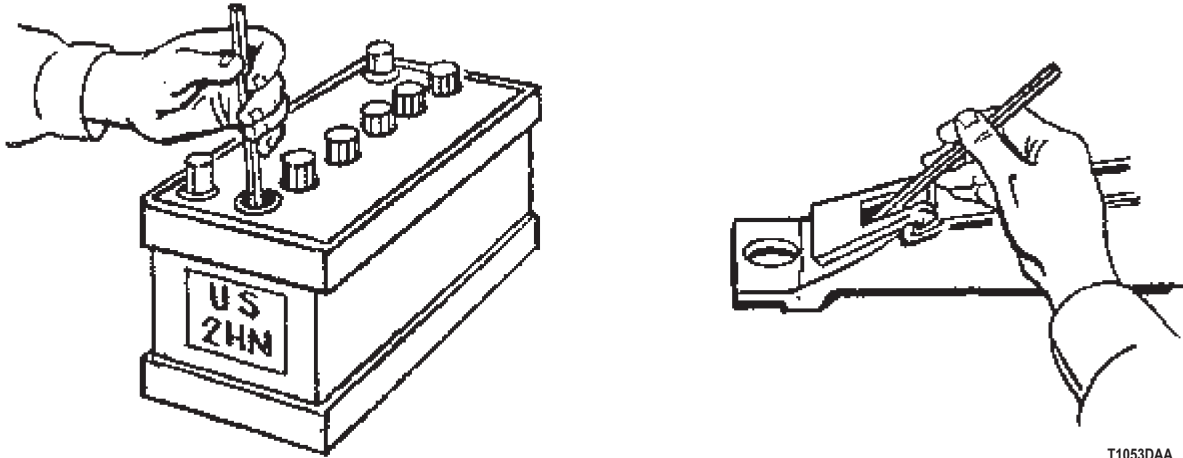

T1053DAA

Figure 4. Specific Gravity Test.

- b. Fill each cell to the fill ring with distilled water (TM 9-6140-200-14).

CONDITION/INDICATION

IS THE ELECTROLYTE IN EACH BATTERY CELL AT THE PROPER LEVEL?

DECISION

- YES - Go to Step (5).
NO - Electrolyte was low. Go to Step (5).

ALL VEHICLE ELECTRICAL SYSTEMS INOPERATIVE - Continued**STEP****5. ARE BATTERIES SPECIFIC GRAVITY READINGS CORRECT?**

- a. Perform a specific gravity test (TM 9-6140-200-14).

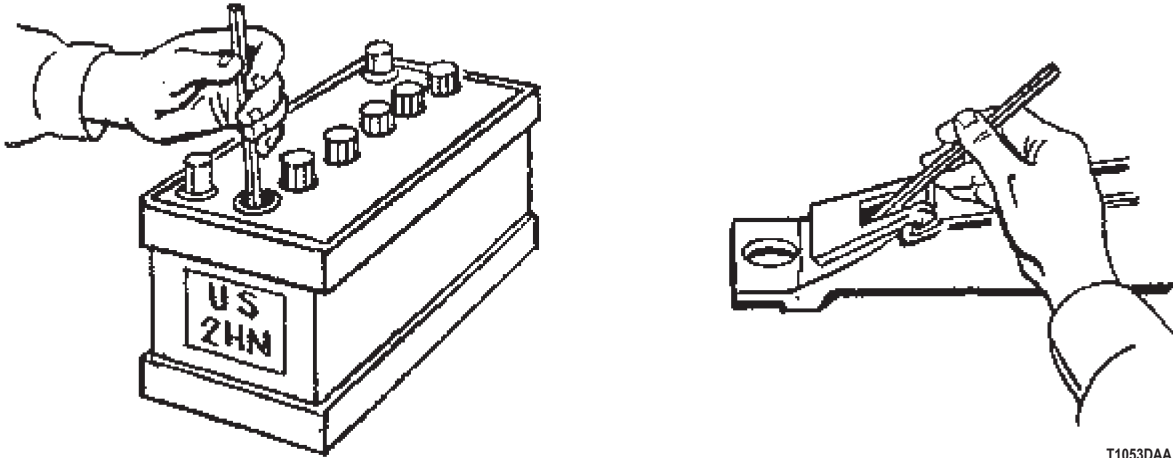

T1053DAA

Figure 5. Specific Gravity Test.

- b. Batteries must test 1.225 or greater, temperature corrected.
- c. Each cell in a battery must test within 25 points of the other cells.
- d. If any battery or batteries do not meet requirements, recharge as required.
- e. Perform specific gravity test again.

CONDITION/INDICATION

ARE BATTERIES SPECIFIC GRAVITY READINGS CORRECT?

DECISION

YES - Go to Step (6).

NO - Replace defective battery (Volume 2, WP 0346). Go to Step (7) to verify problem is solved.

STEP**6. IS THERE CONTINUITY BETWEEN PIN C AND PIN D OF THE PROTECTIVE CONTROL BOX?**

- a. Place battery switch to OFF position.
- b. Disconnect circuit 81 connector from protective control box. Refer to point to point schematics.
- c. Set up multimeter to read ohms.

ALL VEHICLE ELECTRICAL SYSTEMS INOPERATIVE - Continued

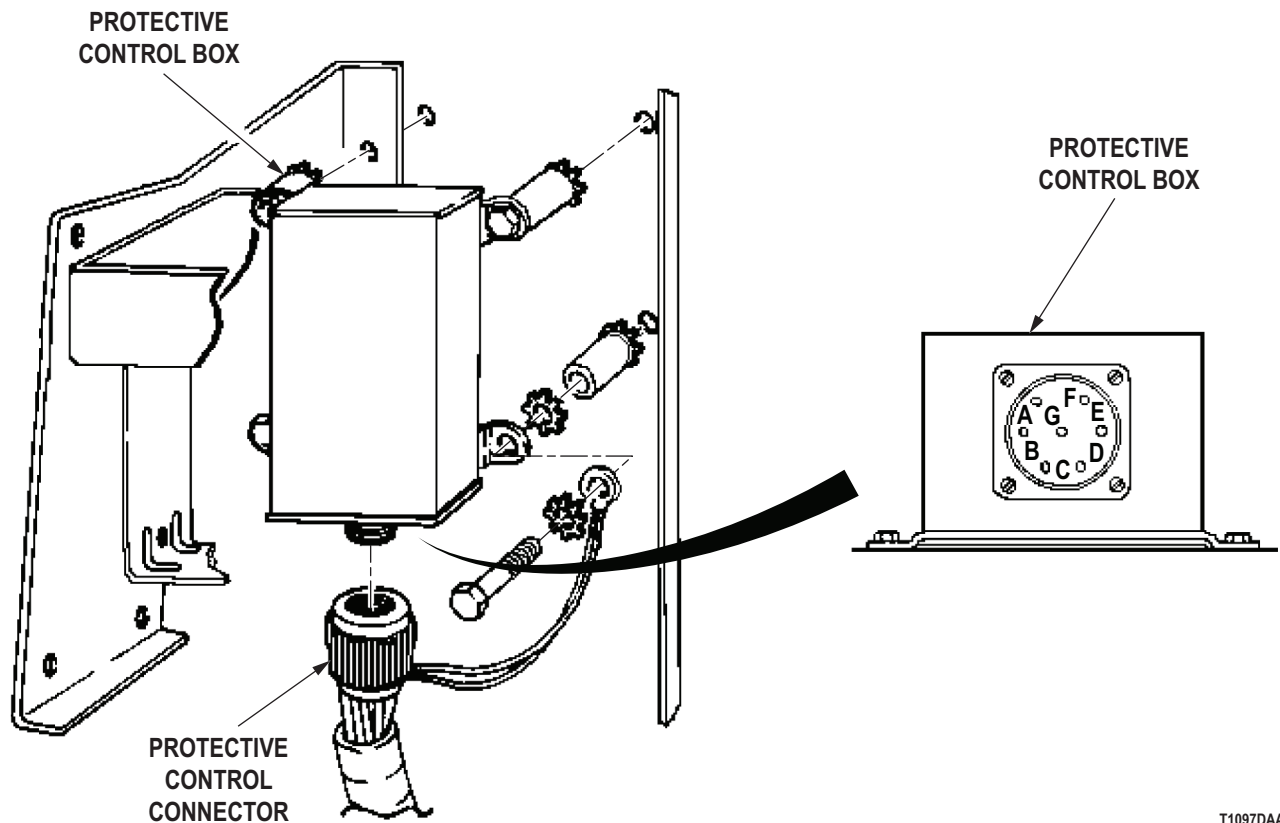

T1097DAA

Figure 6. Protection Control Box Test.

- d. Connect jumper wire between circuit 81 connector, terminal A, and protective control box connector, terminal A.
- e. Connect multimeter red lead to protective control box pin D.
- f. Connect multimeter black lead to protective control box pin C.
- g. Place battery switch to ON position.
- h. Meter reading should be less than 200 ohms.

CONDITION/INDICATION

IS THERE CONTINUITY BETWEEN PIN C AND PIN D OF THE PROTECTIVE CONTROL BOX?

DECISION

YES - Notify supervisor. Action may not be possible at this level of maintenance.

NO - Replace protective control box (Volume 2, WP 0319). Go to Step (7) to verify problem is solved.

ALL VEHICLE ELECTRICAL SYSTEMS INOPERATIVE - Continued**STEP**

7. IS YOUR ORIGINAL PROBLEM STILL PRESENT?
 - a. Ensure vehicle is returned to normal operating condition.
 - b. Check to see if your original problem still exists.

CONDITION/INDICATION

IS YOUR ORIGINAL PROBLEM STILL PRESENT?

DECISION

YES - Notify supervisor.
NO - Problem fixed.

END OF WORK PACKAGE

**FIELD MAINTENANCE
STARTER MOTOR INOPERATIVE**

INITIAL SETUP:**Tools and Special Tools**

Tool Kit, General Mechanic's: Automotive
(Volume 5, WP 0826, Table 1, Item 56)
Multimeter
(Volume 5, WP 0826, Table 1, Item 34)
Test Set, Electronic Systems
(Volume 5, WP 0826, Table 1, Item 51)

References (cont.)

WP 0087
WP 0088
Volume 2, WP 0303

Equipment Condition

Vehicle parked and engine shut down.
(TM 9-2320-272-10)

Personnel Required

(2)

References

Point to Point Schematics

TROUBLESHOOTING PROCEDURE**STARTER MOTOR INOPERATIVE****NOTE**

Conduct these malfunction tests if the starter motor is inoperative. This procedure will check for a faulty starter motor and solenoid.

STARTER MOTOR INOPERATIVE - Continued**STEP**

1. DOES THE STARTER MOTOR SOLENOID ENERGIZE?
 - a. Place battery switch to ON position.

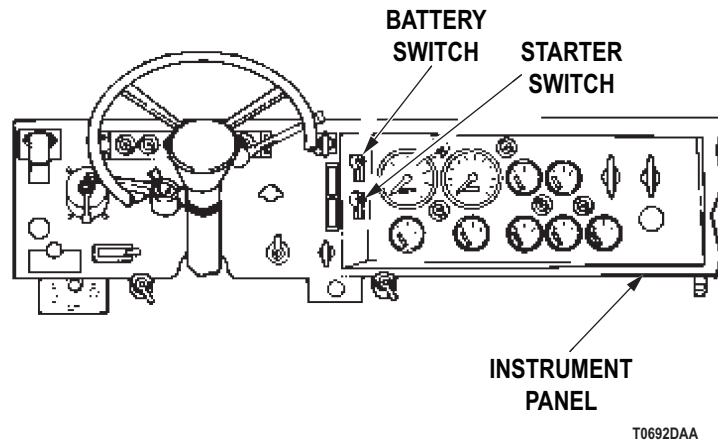

Figure 1. Battery and Starter Switches.

NOTE

If thump is heard when starter switch is position to START, solenoid is energized.

- b. Turn starter switch to START.

CONDITION/INDICATION

DOES THE STARTER MOTOR SOLENOID ENERGIZE?

DECISION

NO - Go to Step (2).

YES - Perform Solenoid Operates, Starter Operates, But Engine Cranks Slowly troubleshooting (WP 0087).

STARTER MOTOR INOPERATIVE - Continued**STEP**

2. IS THERE BATTERY VOLTAGE AT THE STARTER?
 - a. Verify battery switch is set to ON position.
 - b. Set up multimeter to measure VDC.

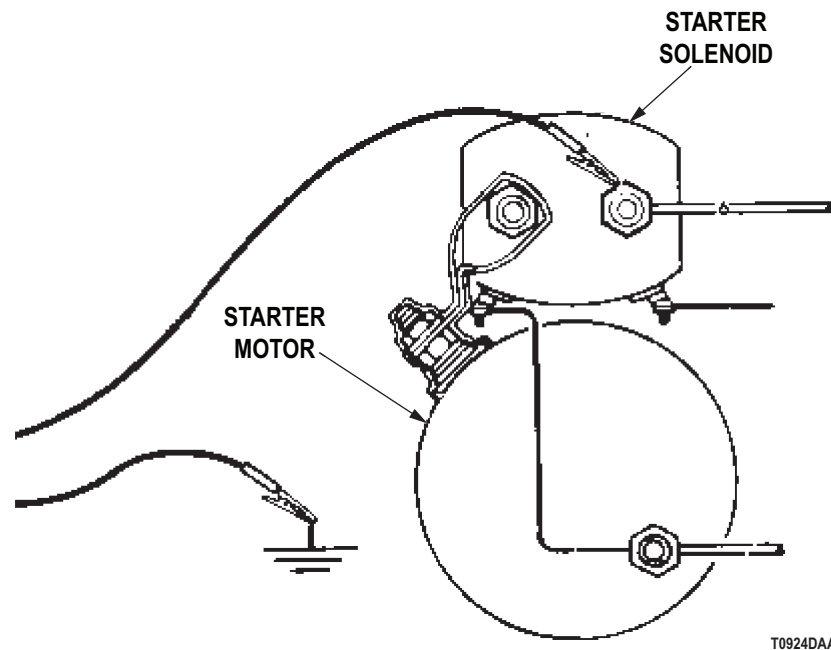

Figure 2. Battery/Solenoid Voltage Test.

- c. Connect multimeter red lead to starter, terminal 6. Refer to point to point schematics.
- d. Connect multimeter black lead to ground.
- e. Turn starter switch to START.
- f. Meter reading should be between 22 and 26 VDC.

CONDITION/INDICATION

IS THERE BATTERY VOLTAGE AT THE STARTER?

DECISION

- NO - Perform Starter Motor Inoperative, No Solenoid Thump troubleshooting (WP 0088).
 YES - Replace starter motor and solenoid (Volume 2, WP 0303). Go to Step (3) to verify problem is solved.

STARTER MOTOR INOPERATIVE - Continued**STEP**

3. IS YOUR ORIGINAL PROBLEM STILL PRESENT?
 - a. Ensure vehicle is returned to normal operating condition.
 - b. Check to see if your original problem still exists.

CONDITION/INDICATION

IS YOUR ORIGINAL PROBLEM STILL PRESENT?

DECISION

YES - Notify supervisor.
NO - Problem fixed.

END OF WORK PACKAGE

FIELD MAINTENANCE
SOLENOID OPERATES, STARTER OPERATES, BUT ENGINE CRANKS SLOWLY

INITIAL SETUP:**Tools and Special Tools**

Tool Kit, General Mechanic's: Automotive
(Volume 5, WP 0826, Table 1, Item 56)
Multimeter
(Volume 5, WP 0826, Table 1, Item 34)
Test Set, Electronic Systems
(Volume 5, WP 0826, Table 1, Item 51)

References (cont.)

TM 9-6140-200-14
Volume 2, WP 0303
Volume 2, WP 0349
Volume 2, WP 0350

Personnel Required

(2)

Equipment Condition

Vehicle parked and engine shut down.
(TM 9-2320-272-10)

References

Point to Point Schematics

TROUBLESHOOTING PROCEDURE**SOLENOID OPERATES, STARTER OPERATES, BUT ENGINE CRANKS SLOWLY****NOTE**

Conduct these malfunction tests if the starter motor and solenoid operate, but the engine cranks slowly. This procedure will check for faulty batteries, starter motor and solenoid. It will also check for bad cable connections at the batteries, starter, and ground.

SOLENOID OPERATES, STARTER OPERATES, BUT ENGINE CRANKS SLOWLY - Continued**STEP**

1. ARE THE BATTERIES OVERHEATING?
 - a. Pull Engine Stop handle to prevent engine from starting.

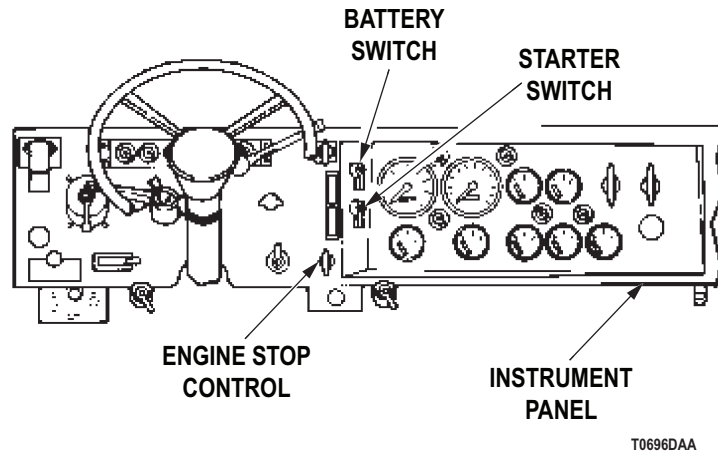

Figure 1. Engine Stop Control Switch.

- b. Crank engine for 15 seconds.
 - c. Check batteries for overheating by feeling battery terminal connections.

CONDITION/INDICATION

ARE THE BATTERIES OVERHEATING?

DECISION

YES - Repair, clean, and tighten all hot battery terminal (Volume 2, WP 0349), starter (Volume 2, WP 0303), and ground (Volume 2, WP 0350) connections. Go to Step (9) to verify problem is solved.
NO - Go to Step (2).

SOLENOID OPERATES, STARTER OPERATES, BUT ENGINE CRANKS SLOWLY - Continued**STEP**

2. IS THE SPECIFIC GRAVITY NORMAL FOR EACH BATTERY?
 - a. Perform a specific gravity test on each battery (TM 9-6140-200-14).

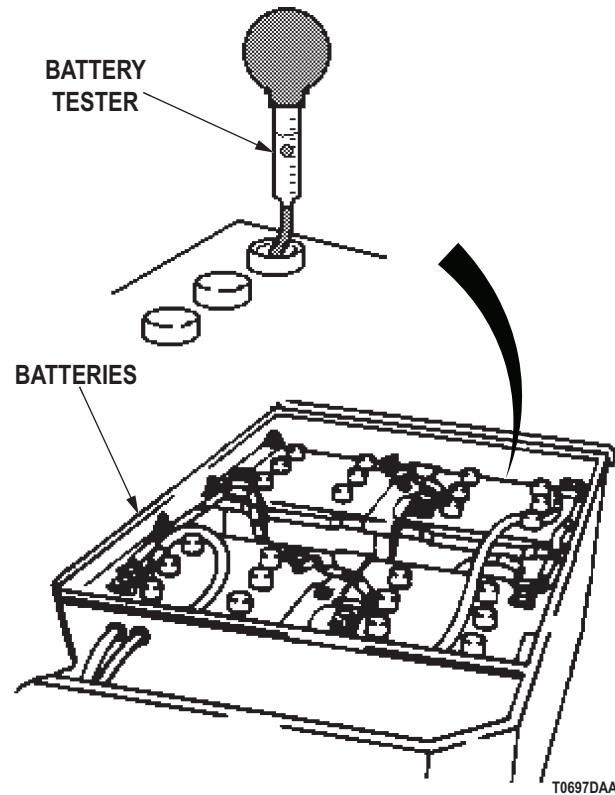

Figure 2. Specific Gravity Test.

- b. Each battery must test 1.225 or greater, temperature corrected.
- c. Each cell in a battery must test within 25 points of the others.

CONDITION/INDICATION

IS THE SPECIFIC GRAVITY NORMAL FOR EACH BATTERY?

DECISION

- NO - Go to Step (3).
YES - Go to Step (4).

SOLENOID OPERATES, STARTER OPERATES, BUT ENGINE CRANKS SLOWLY - Continued**STEP**

3. IS THE SPECIFIC GRAVITY NORMAL FOR EACH BATTERY?
 - a. Charge all batteries that failed the specific gravity test (TM 9-6140-200-14).

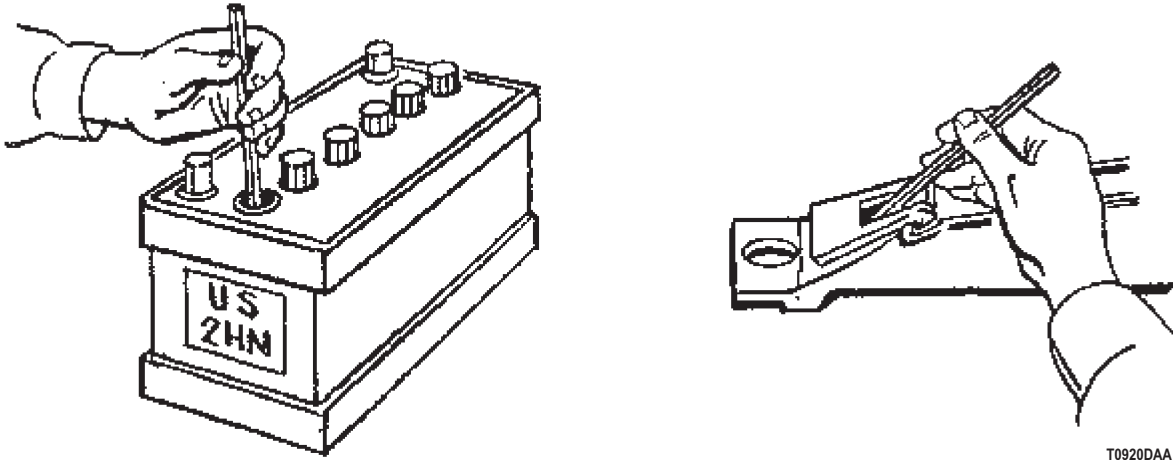

Figure 3. Specific Gravity Test.

- b. Perform another specific gravity test on each newly charged battery.
- c. Each battery must test 1.225 or greater, temperature corrected.
- d. Each cell in a battery must test within 25 points of the others.

CONDITION/INDICATION

IS THE SPECIFIC GRAVITY NORMAL FOR EACH BATTERY?

DECISION

NO - Replace defective battery (Volume 2, WP 0346). Go to Step (9) to verify problem is solved.
YES - Go to Step (4).

SOLENOID OPERATES, STARTER OPERATES, BUT ENGINE CRANKS SLOWLY - Continued**STEP**

4. IS STARTER MOTOR VOLTAGE NORMAL?
 - a. Set up multimeter to measure VDC.

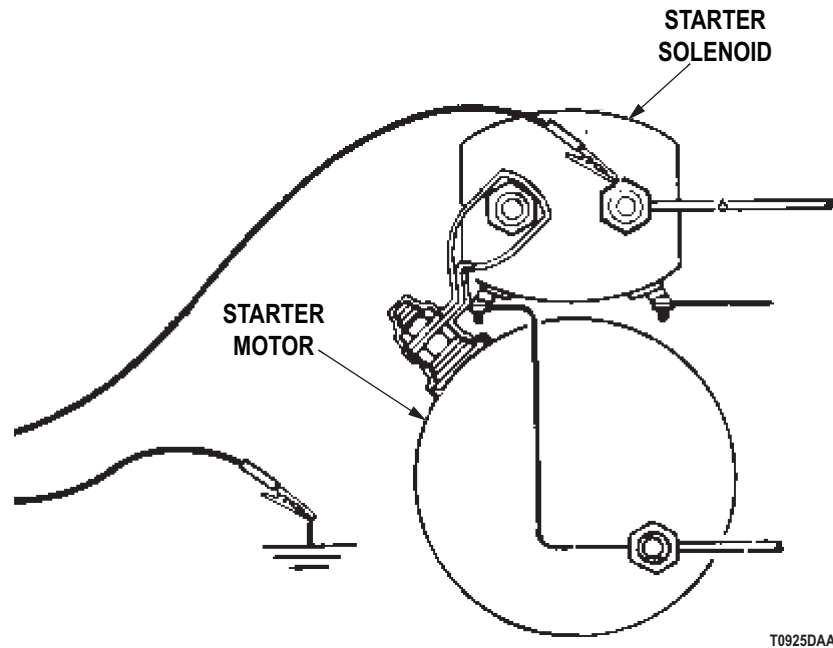

Figure 4. Battery/Solenoid Voltage Test.

- b. Connect multimeter red lead to starter, terminal 6. Refer to point to point schematics.
- c. Connect multimeter black lead to ground.
- d. Turn battery switch to ON position.
- e. Assistant cranks engine.
- f. Meter reading should be 22 VDC or greater while engine is cranked.

CONDITION/INDICATION

IS STARTER MOTOR VOLTAGE NORMAL?

DECISION

NO - Repair, clean, and tighten all battery terminal (Volume 2, WP 0349), starter (Volume 2, WP 0303), and ground (Volume 2, WP 0350) connections. Go to Step (9) to verify problem is solved.
 YES - Go to Step (5).

SOLENOID OPERATES, STARTER OPERATES, BUT ENGINE CRANKS SLOWLY - Continued**STEP**

5. IS STARTER MOTOR TO SOLENOID VOLTAGE DROP NORMAL?
- a. Connect multimeter red lead to motor terminal stud of solenoid. Refer to point to point schematics.

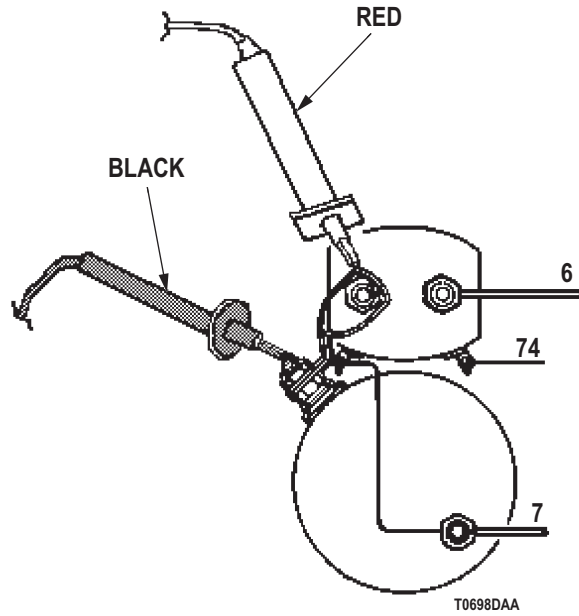

Figure 5. Starter Motor To Solenoid Voltage Drop Test.

- b. Connect multimeter black lead to positive terminal stud of starter motor.
- c. Assistant cranks engine.
- d. Meter reading should be less than or equal to 0.1 VDC while engine is cranked.

CONDITION/INDICATION

IS STARTER MOTOR TO SOLENOID VOLTAGE DROP NORMAL?

DECISION

NO - Repair, clean, and tighten motor to solenoid battery voltage strap terminal connections (Volume 2, WP 0303). Go to Step (9) to verify problem is solved.

YES - Go to Step (6).

SOLENOID OPERATES, STARTER OPERATES, BUT ENGINE CRANKS SLOWLY - Continued**STEP**

6. IS VOLTAGE DROP ACROSS STARTER MOTOR SOLENOID CONTACTS NORMAL?
- a. Connect multimeter red lead to starter motor solenoid terminal as shown. Refer to point to point schematics.

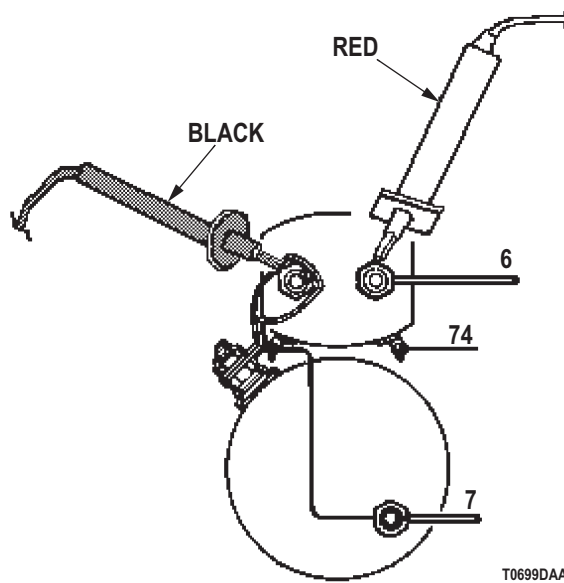

Figure 6. Starter Motor Solenoid Voltage Drop Test.

- b. Connect multimeter black lead to starter motor solenoid terminal as shown.
- c. Assistant cranks engine.
- d. Meter reading should be less than or equal to 0.4 VDC while engine is cranked.

CONDITION/INDICATION

IS VOLTAGE DROP ACROSS STARTER MOTOR SOLENOID CONTACTS NORMAL?

DECISION

NO - Replace starter motor and solenoid assembly (Volume 2, WP 0303). Go to Step (9) to verify problem is solved.

YES - Go to Step (7).

SOLENOID OPERATES, STARTER OPERATES, BUT ENGINE CRANKS SLOWLY - Continued

STEP

7. IS NEGATIVE CABLE 7 VOLTAGE DROP NORMAL BETWEEN BATTERIES AND STARTER MOTOR?

- a. Connect multimeter red lead to terminal stud on end plate of starter motor. Refer to point to point schematics.

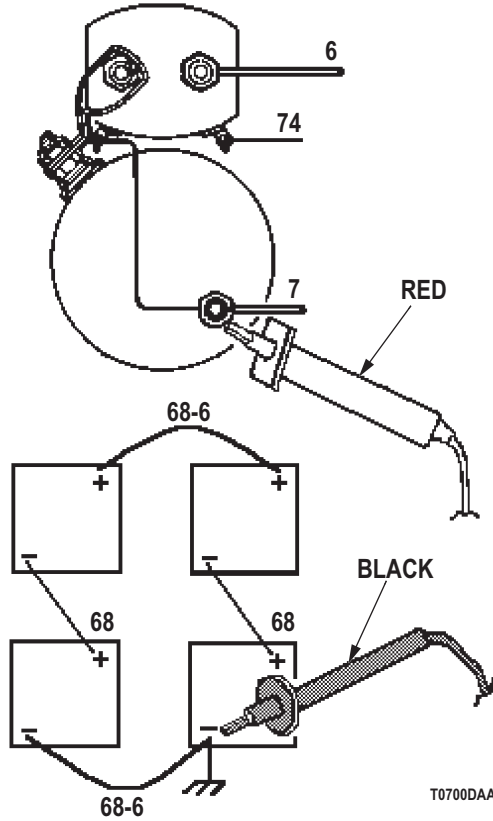

Figure 7. Starter Motor Ground Voltage Drop Test.

- b. Connect multimeter black lead to grounding point at batteries.
- c. Assistant cranks engine.
- d. Meter reading should be less than or equal to 0.4 VDC while engine is cranked.

CONDITION/INDICATION

IS NEGATIVE CABLE 7 VOLTAGE DROP NORMAL BETWEEN BATTERIES AND STARTER MOTOR?

DECISION

NO - Repair, clean, and tighten all cable connections at batteries (Volume 2, WP 0350), starter (Volume 2, WP 0303), and chassis. Go to Step (9) to verify problem is solved.
 YES - Go to Step (8).

SOLENOID OPERATES, STARTER OPERATES, BUT ENGINE CRANKS SLOWLY - Continued

STEP

8. IS POSITIVE CABLE 6 VOLTAGE DROP NORMAL BETWEEN BATTERIES AND STARTER MOTOR?
 - a. Connect multimeter red lead to positive terminal point on batteries. Refer to point to point schematics.

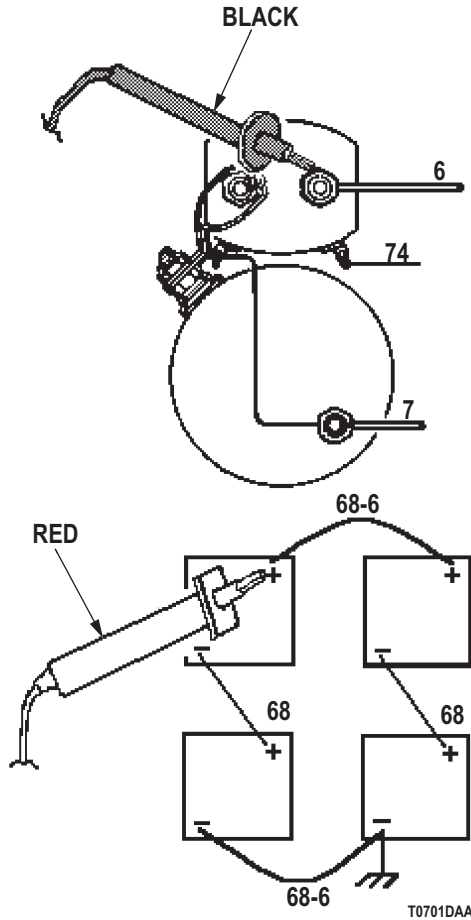

Figure 8. Starter Motor Cable Voltage Drop Test.

- b. Connect multimeter black lead to positive terminal on starter motor solenoid.
- c. Assistant cranks engine.
- d. Meter reading should be less than or equal to 0.4 VDC while engine is cranked.

CONDITION/INDICATION

IS POSITIVE CABLE 6 VOLTAGE DROP NORMAL BETWEEN BATTERIES AND STARTER MOTOR?

DECISION

NO - Repair, clean, and tighten all cable connections at batteries (Volume 2, WP 0349) and starter (Volume 2, WP 0303). Go to Step (9) to verify problem is solved.

YES - Replace starter motor and solenoid assembly (Volume 2, WP 0303). Go to Step (9) to verify problem is solved.

SOLENOID OPERATES, STARTER OPERATES, BUT ENGINE CRANKS SLOWLY - Continued**STEP**

9. IS YOUR ORIGINAL PROBLEM STILL PRESENT?
 - a. Ensure vehicle is returned to normal operating condition.
 - b. Check to see if your original problem still exists.

CONDITION/INDICATION

IS YOUR ORIGINAL PROBLEM STILL PRESENT?

DECISION

YES - Notify supervisor.
NO - Problem fixed.

END OF WORK PACKAGE

FIELD MAINTENANCE
STARTER MOTOR INOPERATIVE; NO SOLENOID THUMP

INITIAL SETUP:**Tools and Special Tools**

Tool Kit, General Mechanic's: Automotive
(Volume 5, WP 0826, Table 1, Item 56)
Multimeter
(Volume 5, WP 0826, Table 1, Item 34)
Test Set, Electronic Systems
(Volume 5, WP 0826, Table 1, Item 51)

Personnel Required

(2)

References

Point to Point Schematics
WP 0084

References (cont.)

Volume 2, WP 0300
Volume 2, WP 0301
Volume 2, WP 0307
Volume 2, WP 0319
Volume 2, WP 0346
Volume 3, WP 0352
Volume 3, WP 0366
Volume 5, WP 0780

Equipment Condition

Vehicle parked and engine shut down.
(TM 9-2320-272-10)

TROUBLESHOOTING PROCEDURE**STARTER MOTOR INOPERATIVE; NO SOLENOID THUMP****NOTE**

Conduct these malfunction tests if the starter motor is inoperative and there is no solenoid thump. This procedure will check for faulty wires 81A/81, 459, 81, 74, 5A/5B, 498, 499, and 566. It will also check for a faulty alternator, battery switch, start switch, neutral start switch, and protective control box.

STARTER MOTOR INOPERATIVE; NO SOLENOID THUMP - Continued**STEP**

1. ARE ELECTRICAL SYSTEMS OTHER THAN THE STARTING SYSTEM NOT WORKING?
 - a. Place battery switch to ON position.

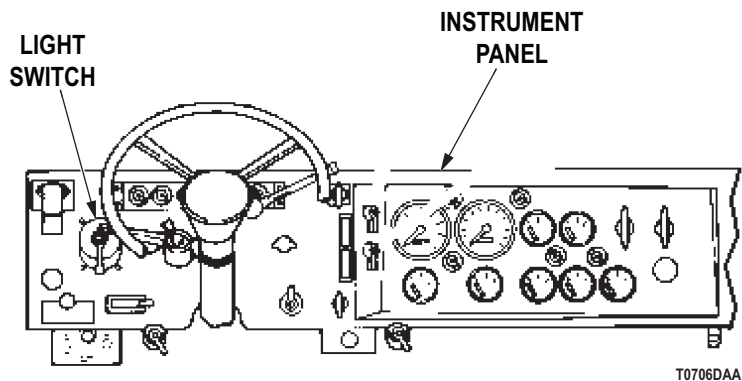

Figure 1. Light Switch.

- b. Check operation of lights.
 - c. If lights fail to function, or are very low in brilliance system fails test.

CONDITION/INDICATION

ARE ELECTRICAL SYSTEMS OTHER THAN THE STARTING SYSTEM NOT WORKING?

DECISION

- YES - Perform Engine Will Not Crank, Some Electrical System Inoperative Or Weak troubleshooting (WP 0084).
NO - Go to Step (2).

STARTER MOTOR INOPERATIVE; NO SOLENOID THUMP - Continued**STEP**

2. DOES THE ENGINE START IF THE STARTER LOCKOUT IS RESET?
 - a. Place battery switch to ON position.

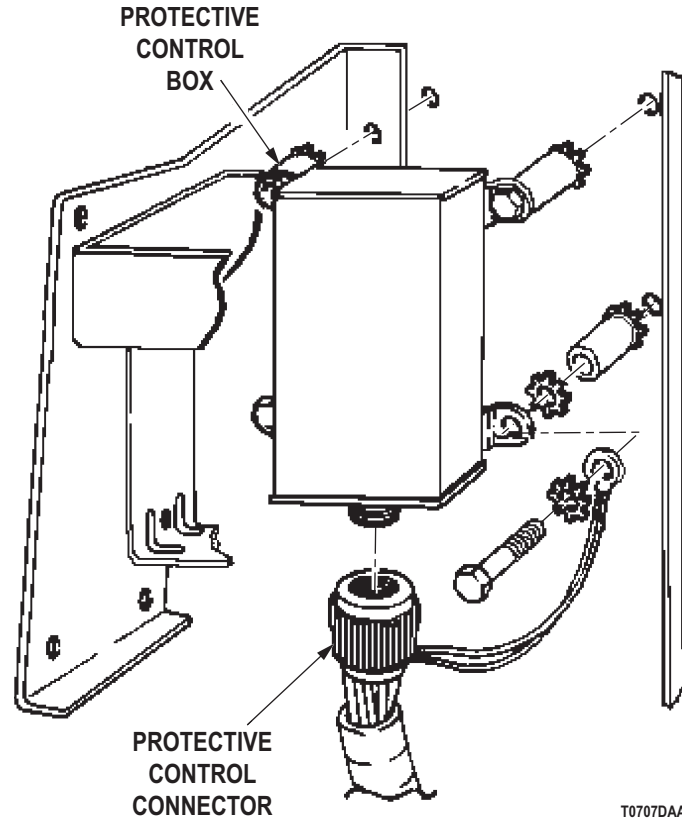

Figure 2. Protective Control Box.

- b. Disconnect harness connector from protective control box.
- c. Reconnect harness connector to protective control box to reset starter lockout switch.
- d. Start engine.

CONDITION/INDICATION

DOES THE ENGINE START IF THE STARTER LOCKOUT IS RESET?

DECISION

NO - Go to Step (3).

YES - Replace alternator M939/A1 60 amp (Volume 2, WP 0300), M939A2 60 amp (Volume 2, WP 0301), 100 amp (Volume 5, WP 0780). Go to Step (15) to verify problem is solved.

STARTER MOTOR INOPERATIVE; NO SOLENOID THUMP - Continued

STEP

3. IS THERE BATTERY VOLTAGE TO PIN A OF THE BATTERY SWITCH?
 - a. Disconnect lead 81A (pin A) from the battery switch.
 - b. Set up multimeter to measure VDC.

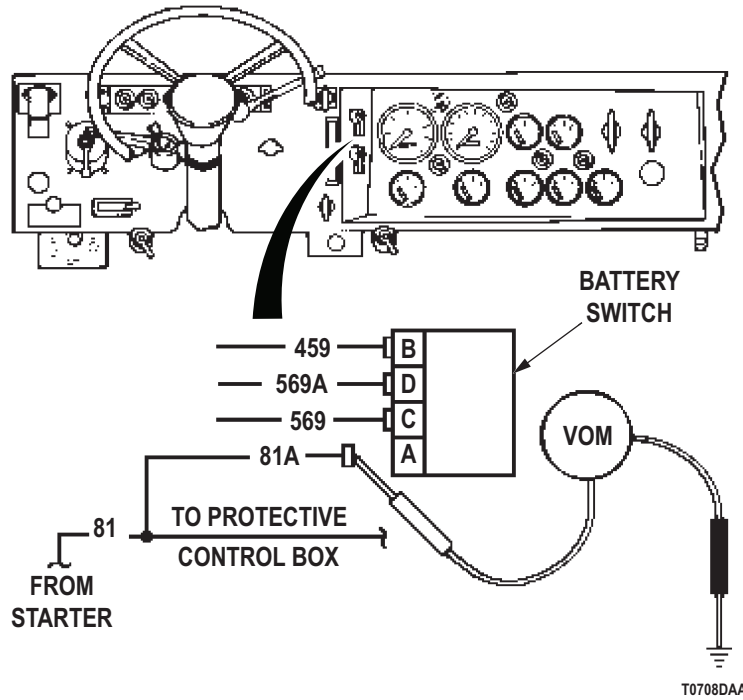

Figure 3. Battery Switch Wire 81A.

- c. Connect multimeter red lead to disconnected lead 81A. Refer to point to point schematics.
- d. Connect multimeter black lead to a known good ground.
- e. Meter reading should be between 22 and 26 VDC.

CONDITION/INDICATION

IS THERE BATTERY VOLTAGE TO PIN A OF THE BATTERY SWITCH?

DECISION

NO - Repair wire 81A/81 (Volume 3, WP 0352). Go to Step (15) to verify problem is solved.
 YES - Go to Step (4).

STARTER MOTOR INOPERATIVE; NO SOLENOID THUMP - Continued

STEP

4. IS THERE BATTERY VOLTAGE TO PIN B OF THE BATTERY SWITCH?
 - a. Reconnect lead 81A to battery switch pin A.
 - b. Disconnect lead 459 (pin B) from the battery switch.

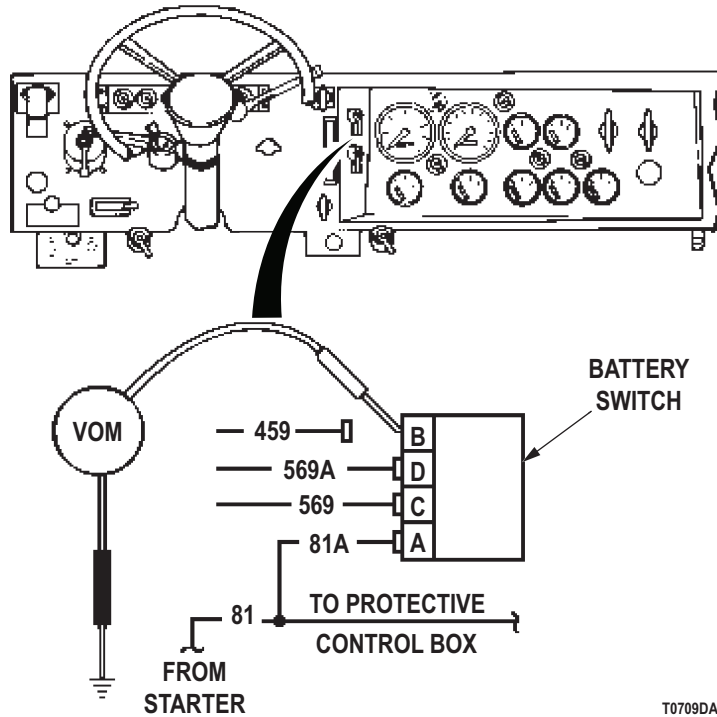

T0709DAA

Figure 4. Battery Switch Test.

- c. Connect multimeter red lead to contact end of pin B. Refer to point to point schematics.
- d. Connect multimeter black lead to a known good ground.
- e. Turn battery switch to ON position.
- f. Meter reading should be between 22 and 26 VDC.

CONDITION/INDICATION

IS THERE BATTERY VOLTAGE TO PIN B OF THE BATTERY SWITCH?

DECISION

- NO - Replace battery switch (Volume 2, WP 0307). Go to Step (15) to verify problem is solved.
 YES - Go to Step (5).

STARTER MOTOR INOPERATIVE; NO SOLENOID THUMP - Continued**STEP**

5. IS THERE BATTERY VOLTAGE AT HARNESS CONNECTOR PIN A?
- Reconnect lead 459 to battery switch pin B.
 - Disconnect harness connector at protective control box.

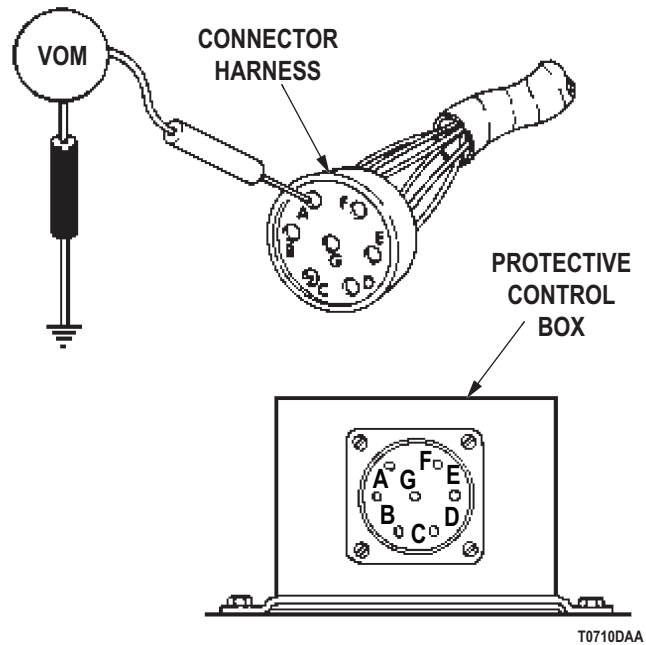

Figure 5. Protective Control Box Wire 459.

- Connect multimeter red lead to harness connector, pin A (lead 459). Refer to point to point schematics.
- Connect multimeter black lead to a known good ground.
- Meter reading should be between 22 and 26 VDC.

CONDITION/INDICATION

IS THERE BATTERY VOLTAGE AT HARNESS CONNECTOR PIN A?

DECISION

- NO - Repair wire 459 (Volume 3, WP 0352). Go to Step (15) to verify problem is solved.
 YES - Go to Step (6).

STARTER MOTOR INOPERATIVE; NO SOLENOID THUMP - Continued**STEP**

6. IS THERE BATTERY VOLTAGE AT HARNESS CONNECTOR PIN C?
- a. Place battery switch to OFF.

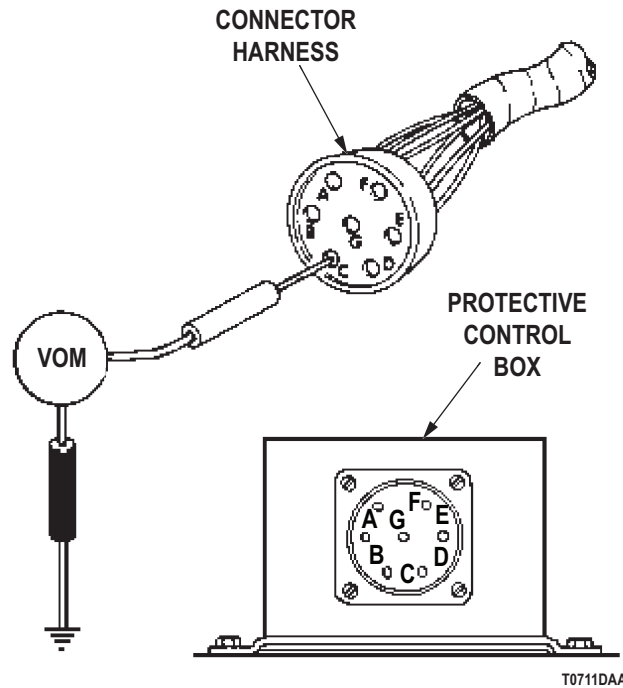

Figure 6. Protective Control Box Wire 81.

- b. Connect multimeter red lead to harness connector, pin C (lead 81). Refer to point to point schematics.
- c. Connect multimeter black lead to a known good ground.
- d. Meter reading should be between 22 and 26 VDC.

CONDITION/INDICATION

IS THERE BATTERY VOLTAGE AT HARNESS CONNECTOR PIN C?

DECISION

NO - Repair wire 81 (Volume 3, WP 0352). Go to Step (15) to verify problem is solved.
 YES - Go to Step (7).

STARTER MOTOR INOPERATIVE; NO SOLENOID THUMP - Continued**STEP**

7. IS THERE CONTINUITY BETWEEN PIN B OF THE PROTECTIVE CONTROL BOX HARNESS CONNECTOR AND LEAD 74 AT THE STARTER SOLENOID?
- Disconnect battery ground cables (Volume 2, WP 0346).
 - Disconnect harness connector at protective control box.
 - Disconnect lead 74 at starter solenoid.
 - Set up multimeter to measure resistance.

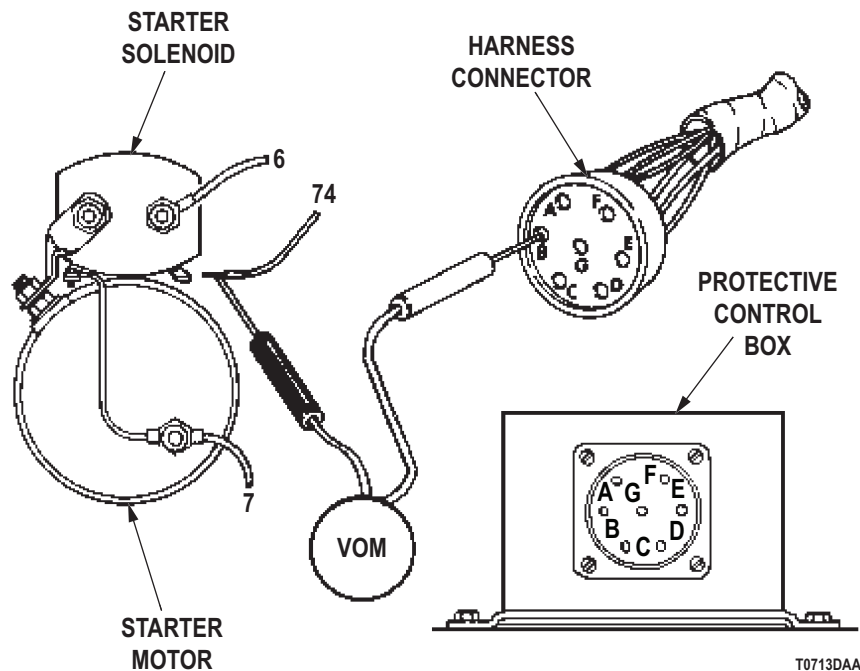

Figure 7. Starter Solenoid Wire 74.

- Connect multimeter red lead to harness connector, pin B (lead 74). Refer to point to point schematics.
- Connect multimeter black lead to lead 74 at the starter solenoid.
- Meter reading should be less than 20 ohms.

CONDITION/INDICATION

IS THERE CONTINUITY BETWEEN PIN B OF THE PROTECTIVE CONTROL BOX HARNESS CONNECTOR AND LEAD 74 AT THE STARTER SOLENOID?

DECISION

NO - Repair wire 74 (Volume 3, WP 0352). Go to Step (15) to verify problem is solved.
 YES - Go to Step (8).

STARTER MOTOR INOPERATIVE; NO SOLENOID THUMP - Continued

STEP

8. IS THERE CONTINUITY BETWEEN PIN D OF THE HARNESS CONNECTOR AND CONTACT END OF 5B AT START SWITCH?
 - a. Connect lead 74 to starter solenoid.
 - b. Disconnect lead 5B (pin B) at start switch.

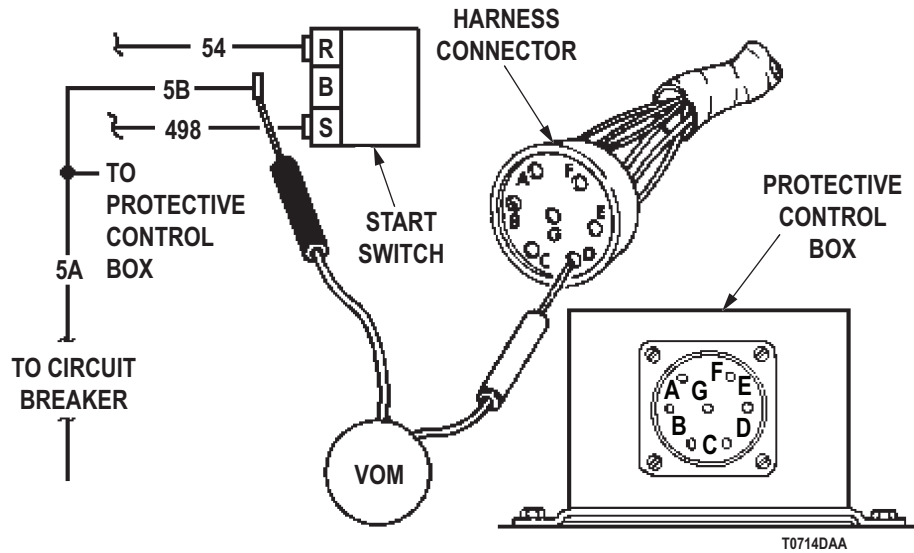

Figure 8. Start Switch Wire 5B.

- c. Connect multimeter red lead to harness connector, pin D (lead 5A/5B). Refer to point to point schematics.
- d. Connect multimeter black lead to contact end of 5B at start switch.
- e. Meter reading should be less than 20 ohms.

CONDITION/INDICATION

IS THERE CONTINUITY BETWEEN PIN D OF THE HARNESS CONNECTOR AND CONTACT END OF 5B AT START SWITCH?

DECISION

NO - Repair wire 5A/5B (Volume 3, WP 0352). Go to Step (15) to verify problem is solved.
 YES - Go to Step (9).

STARTER MOTOR INOPERATIVE; NO SOLENOID THUMP - Continued**STEP**

9. IS THERE CONTINUITY BETWEEN PINS B AND S OF THE START SWITCH?

- a. Disconnect lead 5B (pin B) and lead 498 (pin S) at start switch.

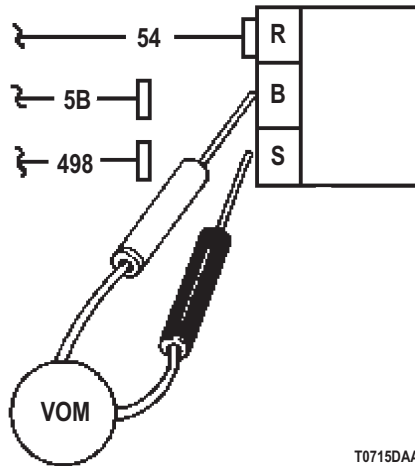

T0715DAA

Figure 9. Start Switch.

- b. Connect multimeter red lead to pin B of the start switch. Refer to point to point schematics.
 c. Connect multimeter black lead to pin S of the start switch.
 d. Position and hold start switch in the START position.
 e. Meter reading should be less than 20 ohms.

CONDITION/INDICATION

IS THERE CONTINUITY BETWEEN PINS B AND S OF THE START SWITCH?

DECISION

NO - Replace start switch (Volume 2, WP 0307). Go to Step (15) to verify problem is solved.
 YES - Go to Step (10).

STEP

10. IS THERE CONTINUITY BETWEEN CONTACT END OF LEAD 498 AT START SWITCH AND CONTACT END OF LEAD 498 AT NEUTRAL START SWITCH?

- a. Reconnect lead 5B to start switch (pin B).
 b. Set parking brake.
 c. Disconnect lead 498 at start switch.
 d. Disconnect lead 498 at neutral start switch.

STARTER MOTOR INOPERATIVE; NO SOLENOID THUMP - Continued

Figure 10. Neutral Start Switch Wire 498.

- e. Connect multimeter red lead to contact end of lead 498 at start switch. Refer to point to point schematics.
- f. Connect multimeter black lead to contact end of lead 498 at neutral start switch.
- g. Meter reading should be less than 20 ohms.

CONDITION/INDICATION

IS THERE CONTINUITY BETWEEN CONTACT END OF LEAD 498 AT START SWITCH AND CONTACT END OF LEAD 498 AT NEUTRAL START SWITCH?

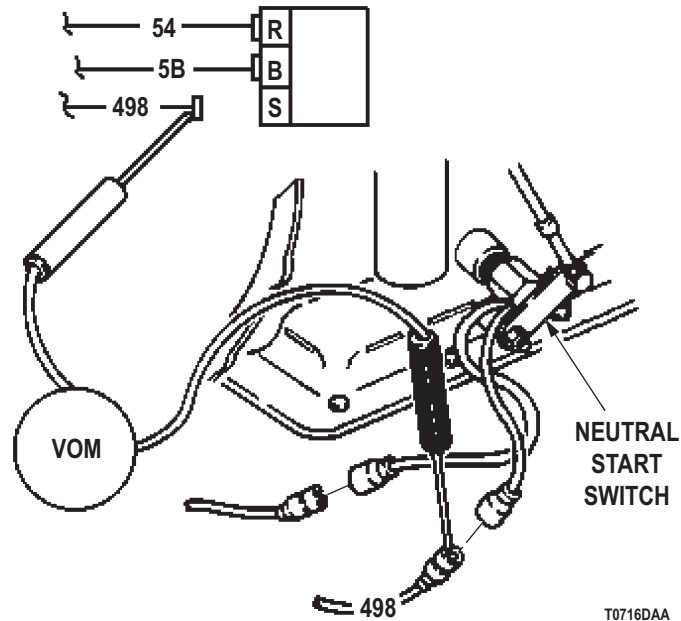
DECISION

NO - Repair wire 498 (Volume 3, WP 0352). Go to Step (15) to verify problem is solved.
 YES - Go to Step (11).

STARTER MOTOR INOPERATIVE; NO SOLENOID THUMP - Continued**STEP**

11. IS THERE CONTINUITY BETWEEN NEUTRAL START SWITCH CONTACT END OF LEAD 499 AND NEUTRAL START SWITCH CONTACT END OF LEAD 498?
- Reconnect lead 498 to start switch (pin S).
 - Disconnect lead 499 at neutral start switch.
 - Ensure transmission is in neutral.

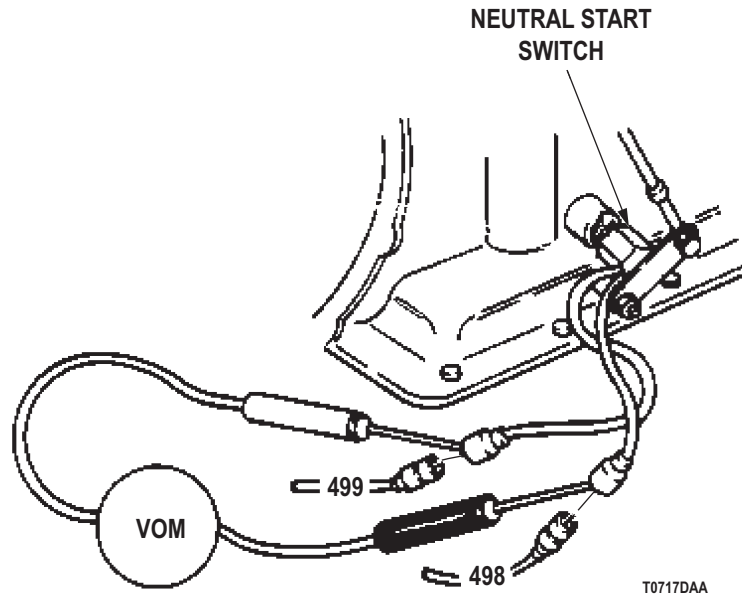

Figure 11. Neutral Start Switch.

- Connect multimeter red lead to neutral start switch contact end of lead 499. Refer to point to point schematics.
- Connect multimeter black lead to neutral start switch contact end of lead 498.
- Meter reading should be less than 20 ohms.

CONDITION/INDICATION

IS THERE CONTINUITY BETWEEN NEUTRAL START SWITCH CONTACT END OF LEAD 499 AND NEUTRAL START SWITCH CONTACT END OF LEAD 498?

DECISION

NO - Replace neutral start switch (Volume 3, WP 0366). Go to Step (15) to verify problem is solved.
 YES - Go to Step (12).

STARTER MOTOR INOPERATIVE; NO SOLENOID THUMP - Continued**STEP**

12. IS THERE CONTINUITY BETWEEN CONTACT END OF LEAD 498 AT START SWITCH AND CONTACT END OF LEAD 498 AT NEUTRAL START SWITCH?
- Reconnect lead 498 to neutral start switch.
 - Disconnect harness connector at protective control box.

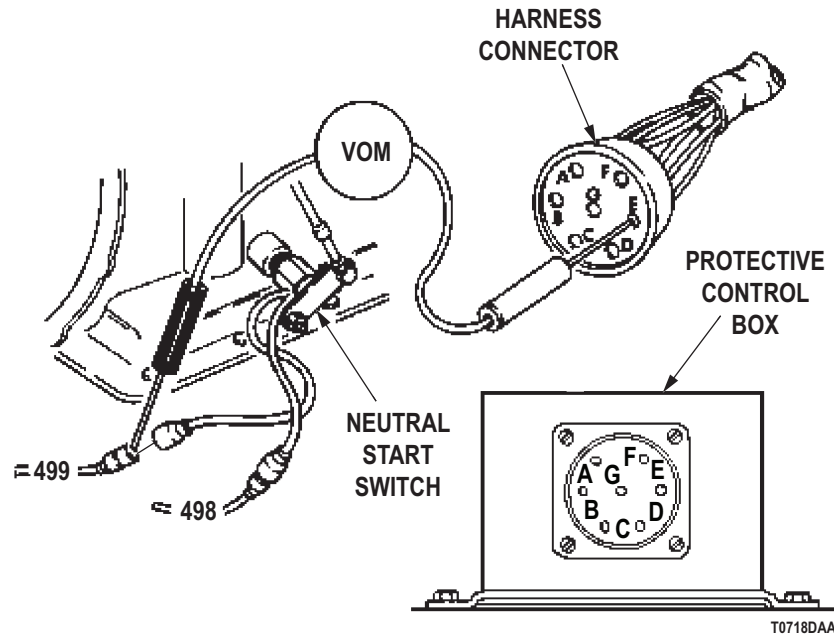

Figure 12. Protective Control Box Wire 499.

- Connect multimeter red lead to contact end of lead 499. Refer to point to point schematics.
- Connect multimeter black lead to harness connector, pin E (lead 499).
- Meter reading should be less than 20 ohms.

CONDITION/INDICATION

IS THERE CONTINUITY BETWEEN CONTACT END OF LEAD 498 AT START SWITCH AND CONTACT END OF LEAD 498 AT NEUTRAL START SWITCH?

DECISION

NO - Repair wire 499 (Volume 3, WP 0352). Go to Step (15) to verify problem is solved.
 YES - Go to Step (13).

STARTER MOTOR INOPERATIVE; NO SOLENOID THUMP - Continued

STEP

13. IS THERE CONTINUITY BETWEEN PIN F AT HARNESS CONNECTOR AND CONTACT END OF LEAD 566 AT ALTERNATOR?
 - a. Reconnect lead 499 to neutral start switch.
 - b. Disconnect lead 566 at alternator.
 - c. Disconnect harness connector at protective control box.

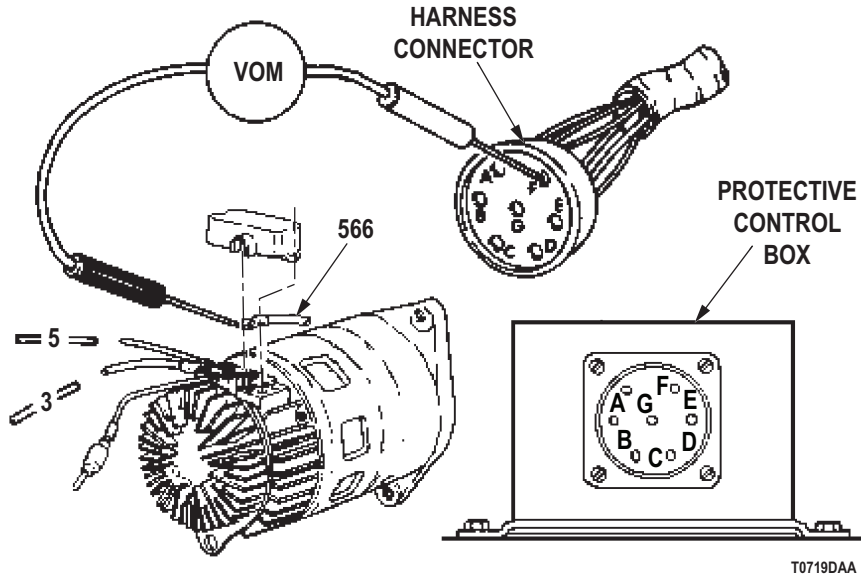

Figure 13. Alternator Wire 566.

- d. Connect multimeter red lead to harness connector, pin F (lead 566). Refer to point to point schematics.
- e. Connect multimeter black lead to contact end of lead 566 at alternator.
- f. Meter reading should be less than 20 ohms.

CONDITION/INDICATION

IS THERE CONTINUITY BETWEEN PIN F AT HARNESS CONNECTOR AND CONTACT END OF LEAD 566 AT ALTERNATOR?

DECISION

NO - Repair wire 566 (Volume 3, WP 0352). Go to Step (15) to verify problem is solved.
 YES - Go to Step (14).

STARTER MOTOR INOPERATIVE; NO SOLENOID THUMP - Continued

STEP

14. DOES ENGINE START WITH LEAD 566 DISCONNECTED FROM ALTERNATOR?
 - a. Reconnect harness connector to protective control box.

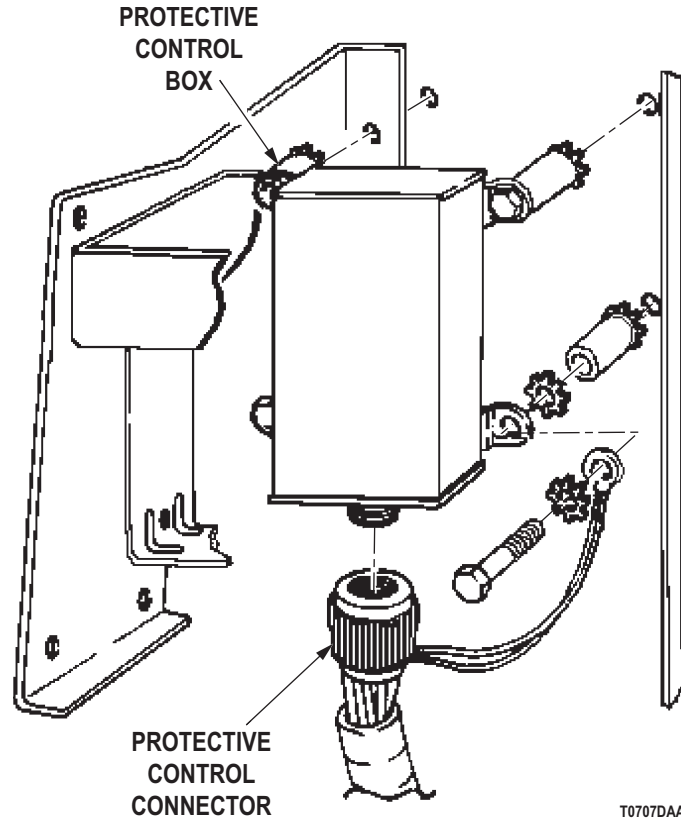

Figure 14. Protective Control Box.

- b. Verify lead 566 disconnected from alternator. Refer to point to point schematics.
 - c. Attempt to start engine.

CONDITION/INDICATION

DOES ENGINE START WITH LEAD 566 DISCONNECTED FROM ALTERNATOR?

DECISION

NO - Replace protective control box (Volume 2, WP 0319). Go to Step (15) to verify problem is solved.
 YES - Replace alternator M939/A1 60 amp (Volume 2, WP 0300), M939A2 60amp (Volume 2, WP 0301), 100 amp (Volume 5, WP 0780). Go to Step (15) to verify problem is solved.

STARTER MOTOR INOPERATIVE; NO SOLENOID THUMP - Continued**STEP**

15. IS YOUR ORIGINAL PROBLEM STILL PRESENT?
- a. Ensure vehicle is returned to normal operating condition.
 - b. Check to see if your original problem still exists.

CONDITION/INDICATION

IS YOUR ORIGINAL PROBLEM STILL PRESENT?

DECISION

YES - Notify supervisor.
NO - Problem fixed.

END OF WORK PACKAGE

**FIELD MAINTENANCE
NO OR LOW ALTERNATOR OUTPUT**

INITIAL SETUP:**Tools and Special Tools**

Tool Kit, General Mechanic's: Automotive
(Volume 5, WP 0826, Table 1, Item 56)
Multimeter
(Volume 5, WP 0826, Table 1, Item 34)
Test Set, Electronic Systems
(Volume 5, WP 0826, Table 1, Item 51)

Personnel Required

(2)

References

Point to Point Schematics

References (cont.)

Volume 2, WP 0296
Volume 2, WP 0297
Volume 2, WP 0300
Volume 2, WP 0301
Volume 2, WP 0302
Volume 2, WP 0346
Volume 3, WP 0352
Volume 5, WP 0780

Equipment Condition

Vehicle parked and engine shut down.
(TM 9-2320-272-10)

TROUBLESHOOTING PROCEDURE**NO OR LOW ALTERNATOR OUTPUT****NOTE**

Conduct these malfunction tests if there is no or low output from the alternator. This procedure will check the alternator belts, alternator, wire 568, and wire 5.

NO OR LOW ALTERNATOR OUTPUT - Continued**STEP**

1. DO THE ALTERNATOR DRIVE BELTS HAVE THE PROPER TENSION?
 - a. Verify engine is stopped.

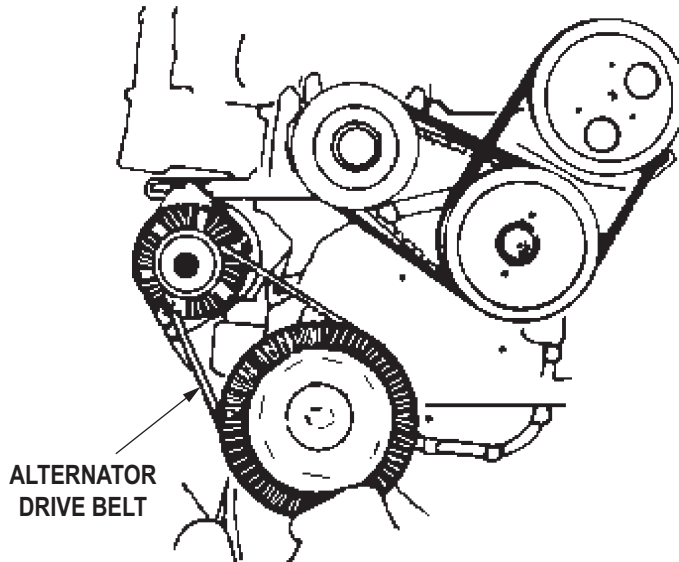

T0932DAA

Figure 1. Alternator Drive Belt.

- b. Inspect alternator belts for damage and proper tension M939/A1 (Volume 2, WP 0297), M939A2 (Volume 2, WP 0296).

CONDITION/INDICATION

DO THE ALTERNATOR DRIVE BELTS HAVE THE PROPER TENSION?

DECISION

NO - Adjust or replace alternator belt M939/A1 (Volume 2, WP 0297), M939A2 (Volume 2, WP 0296). Go to Step (8) to verify problem is solved.
 YES - Go to Step (2).

STEP

2. IS THE ALTERNATOR OUTPUT VOLTAGE NORMAL?
 - a. Verify engine is stopped.
 - b. Set up multimeter to measure VDC.

NO OR LOW ALTERNATOR OUTPUT - Continued

Figure 2. DCA Connector.

- c. Connect multimeter red lead to vehicle DCA connector, terminal N. Refer to point to point schematics.
- d. Connect multimeter black lead to vehicle DCA connector, terminal P.
- e. Start engine and run at fast idle.
- f. Meter reading should be between 26.5 and 29.5 VDC.

CONDITION/INDICATION

IS THE ALTERNATOR OUTPUT VOLTAGE NORMAL?

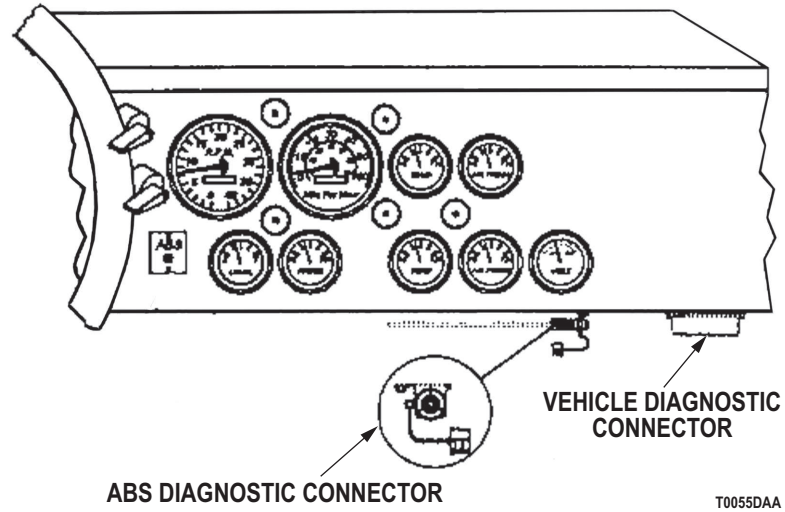
DECISION

- NO - Go to Step (3).
 YES - Go to Step (4).

NO OR LOW ALTERNATOR OUTPUT - Continued**STEP**

3. IS A 100 AMP ALTERNATOR INSTALLED?
 - a. Stop engine.

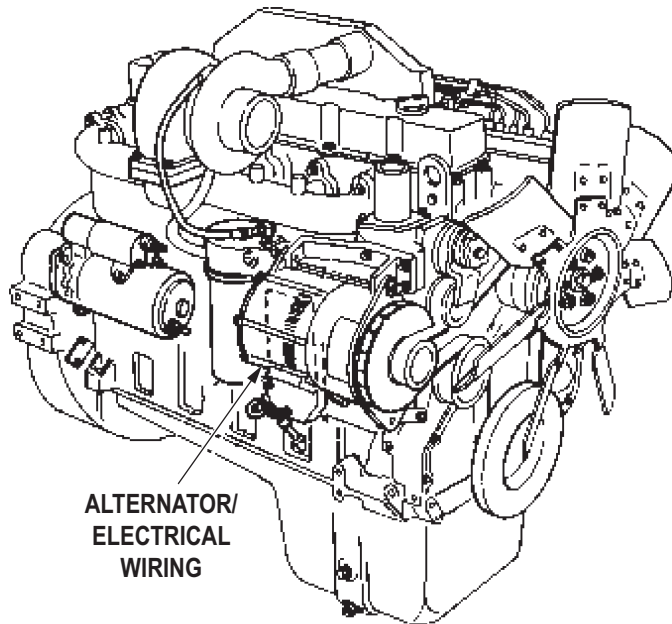

T0930DAA

Figure 3. Alternator Electrical Wiring.

NOTE

100 amp alternators are equipped with a quick disconnect connector.

- b. Determine which alternator is in your vehicle.

CONDITION/INDICATION

IS A 100 AMP ALTERNATOR INSTALLED?

DECISION

YES - Replace 100 amp alternator (Volume 5, WP 0780). Go to Step (8) to verify problem is solved.
 NO - Replace 60 amp alternator M939/A1 (Volume 2, WP 0300), M939A2 (Volume 2, WP 0301). Go to Step (8) to verify problem is solved.

NO OR LOW ALTERNATOR OUTPUT - Continued**STEP**

4. IS THERE BATTERY VOLTAGE AT WIRE 568 AT THE ALTERNATOR?
 - a. Stop engine.
 - b. Disconnect wire 568 from the alternator.

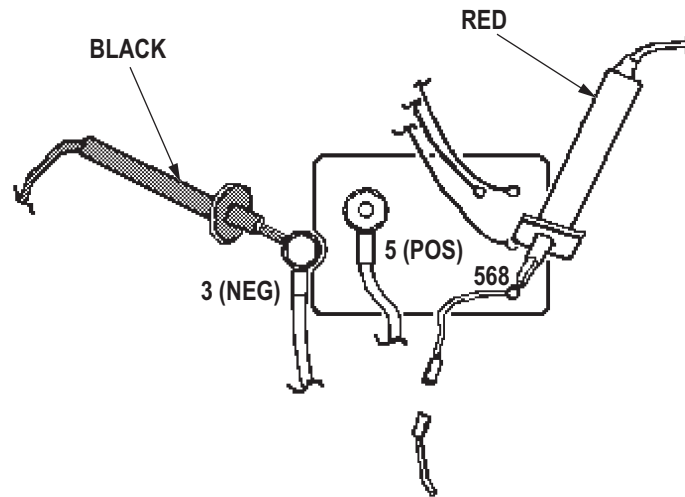

T0937DAA

Figure 4. Alternator Wire 568.

- c. Place battery switch to ON position.
- d. Connect multimeter red lead to lead 568. Refer to point to point schematics.
- e. Connect multimeter black lead to vehicle ground.
- f. Meter reading should be between 22 and 26 VDC.

CONDITION/INDICATION

IS THERE BATTERY VOLTAGE AT WIRE 568 AT THE ALTERNATOR?

DECISION

- NO - Go to Step (6).
 YES - Go to Step (5).

NO OR LOW ALTERNATOR OUTPUT - Continued**STEP**

5. IS A 100 AMP ALTERNATOR INSTALLED?
 - a. Place battery switch to OFF position.

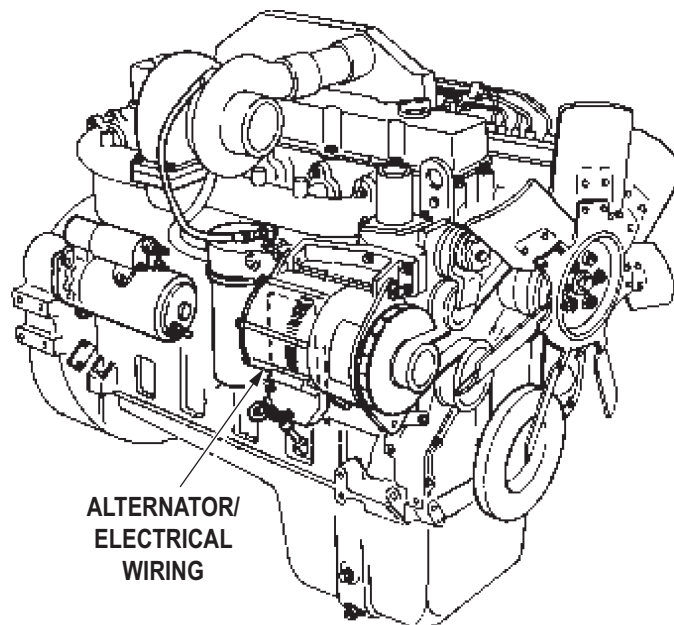

T0930DAA

Figure 5. Alternator Wiring.

NOTE

100 amp alternators are equipped with a quick disconnect connector.

- b. Determine which alternator is in your vehicle.

CONDITION/INDICATION

IS A 100 AMP ALTERNATOR INSTALLED?

DECISION

YES - Replace 100 amp alternator (Volume 5, WP 0780). Go to Step (8) to verify problem is solved.
NO - Replace 60 amp alternator M939/A1 (Volume 2, WP 0300), M939A2 (Volume 2, WP 0301). Go to Step (8) to verify problem is solved.

NO OR LOW ALTERNATOR OUTPUT - Continued**STEP****6. IS THERE BATTERY VOLTAGE AT WIRE 5 AT THE ALTERNATOR TERMINAL?**

- a. Connect multimeter red lead to circuit 5 at the alternator terminal. Refer to point to point schematics.

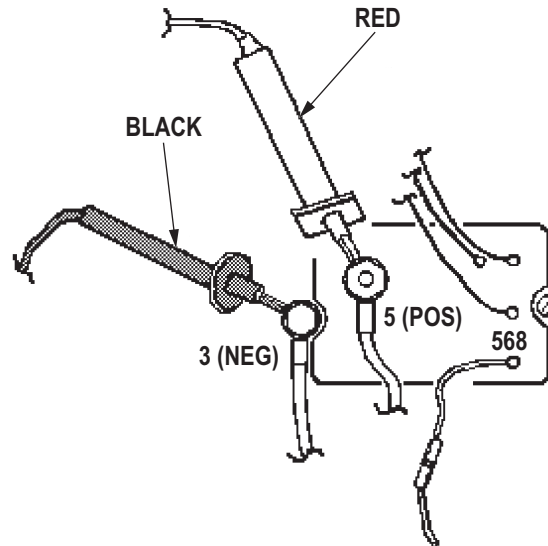

T0936DAA

Figure 6. Alternator Wire 5.

- b. Connect multimeter black lead to vehicle ground.
- c. Meter reading should be between 22 and 26 VDC.

CONDITION/INDICATION

IS THERE BATTERY VOLTAGE AT WIRE 5 AT THE ALTERNATOR TERMINAL?

DECISION

NO - Go to Step (7).

YES - Repair wire 568 (Volume 3, WP 0352). Go to Step (8) to verify problem is solved.

NO OR LOW ALTERNATOR OUTPUT - Continued**STEP****7. IS THERE CONTINUITY BETWEEN CIRCUIT 5 AND CIRCUIT 568?**

- a. Disconnect battery negative cable (Volume 2, WP 0346).
- b. Set up multimeter to measure resistance.

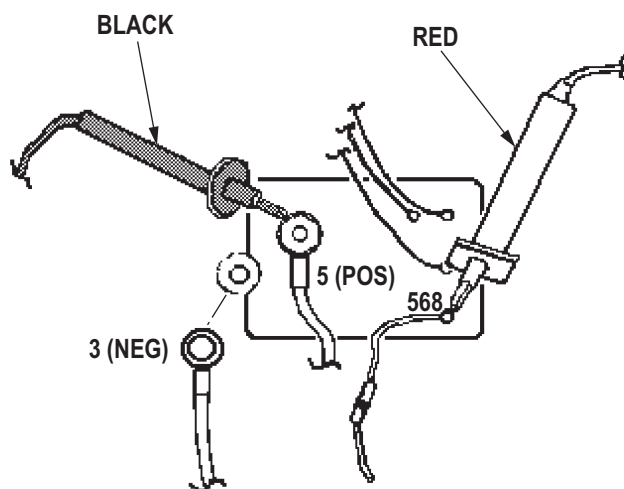

T0938DAA

Figure 7. Alternator Wire 5/568.

- c. Connect multimeter red lead to circuit 568. Refer to point to point schematics.
- d. Connect multimeter black lead to circuit 5 at the alternator terminal.
- e. Meter reading should be less than 20 ohms.

CONDITION/INDICATION

IS THERE CONTINUITY BETWEEN CIRCUIT 5 AND CIRCUIT 568?

DECISION

NO - Repair wire 568 (Volume 3, WP 0352). Go to Step (8) to verify problem is solved.
 YES - Notify supervisor. Action may not be possible at this level of maintenance.

NO OR LOW ALTERNATOR OUTPUT - Continued**STEP**

8. IS YOUR ORIGINAL PROBLEM STILL PRESENT?
 - a. Ensure vehicle is returned to normal operating condition.
 - b. Check to see if your original problem still exists.

CONDITION/INDICATION

IS YOUR ORIGINAL PROBLEM STILL PRESENT?

DECISION

YES - Notify supervisor.
NO - Problem fixed.

END OF WORK PACKAGE

FIELD MAINTENANCE
NO ALTERNATOR OUTPUT (100 AMP ALTERNATOR)

INITIAL SETUP:**Tools and Special Tools**

Tool Kit, General Mechanic's: Automotive
(Volume 5, WP 0826, Table 1, Item 56)
Multimeter
(Volume 5, WP 0826, Table 1, Item 34)
Test Set, Electronic Systems
(Volume 5, WP 0826, Table 1, Item 51)

References (cont.)

Volume 2, WP 0296
Volume 2, WP 0297
Volume 2, WP 0302
Volume 3, WP 0352
Volume 5, WP 0780
Volume 5, WP 0792

Personnel Required

(2)

Equipment Condition

Vehicle parked and engine shut down.
(TM 9-2320-272-10)

References

Point to Point Schematics

TROUBLESHOOTING PROCEDURE**NO ALTERNATOR OUTPUT (100 AMP ALTERNATOR)****NOTE**

Conduct these malfunction tests if there is no output from the alternator. This procedure will check the alternator belts, alternator, starter, and voltage regulator harness.

NO ALTERNATOR OUTPUT (100 AMP ALTERNATOR) - Continued**STEP**

1. DO THE ALTERNATOR DRIVE BELTS HAVE THE PROPER TENSION?
 - a. Verify engine is stopped.

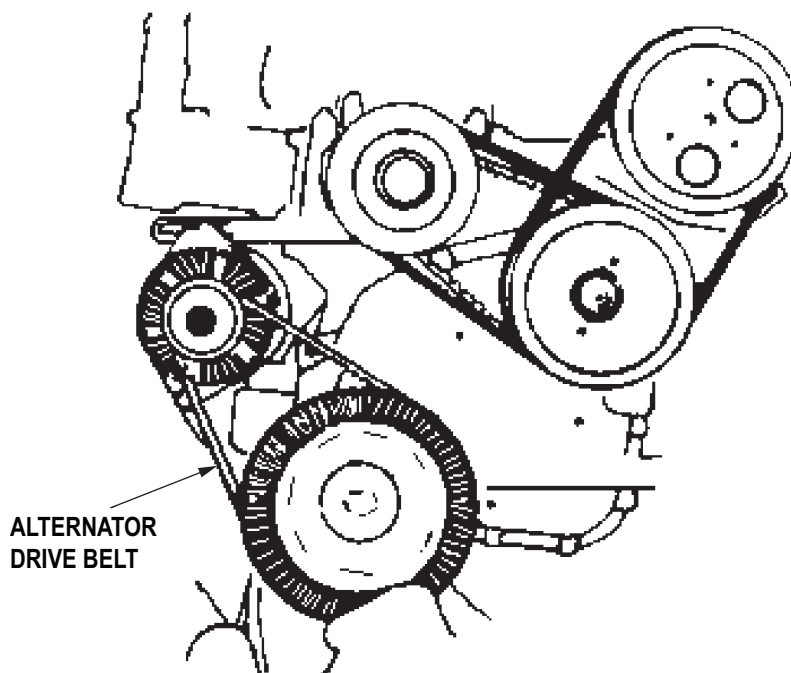

T0164DAA

Figure 1. Alternator Drive Belt.

- b. Inspect alternator belts for damage and proper tension M939/A1 (Volume 2, WP 0297), M939A2 (Volume 2, WP 0296).

CONDITION/INDICATION

DO THE ALTERNATOR DRIVE BELTS HAVE THE PROPER TENSION?

DECISION

NO - Adjust or replace alternator belt M939/A1 (Volume 2, WP 0297), M939A2 (Volume 2, WP 0296). Go to Step (12) to verify problem is solved.
YES - Go to Step (2).

NO ALTERNATOR OUTPUT (100 AMP ALTERNATOR) - Continued**STEP**

2. IS THE ALTERNATOR OUTPUT VOLTAGE NORMAL?
 - a. Verify engine is stopped.
 - b. Set up multimeter to measure VDC.

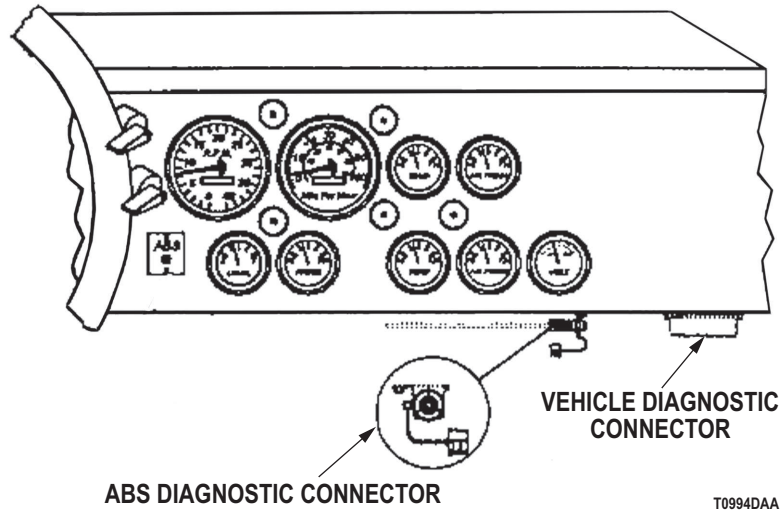

Figure 2. DCA Connector.

- c. Connect multimeter red lead to vehicle DCA connector, terminal N. Refer to point to point schematics.
- d. Connect multimeter black lead to vehicle DCA connector, terminal P.
- e. Start engine and run at fast idle.
- f. Meter reading should be between 26.5 and 29.5 VDC.

CONDITION/INDICATION

IS THE ALTERNATOR OUTPUT VOLTAGE NORMAL?

DECISION

NO - Replace defective alternator (Volume 5, WP 0780). Go to Step (12) to verify problem is solved.
 YES - Go to Step (3).

NO ALTERNATOR OUTPUT (100 AMP ALTERNATOR) - Continued

STEP

3. IS THERE CONTINUITY BETWEEN PIN F OF THE VOLTAGE REGULATOR HARNESS CONNECTOR AND LEAD 566 OF THE VOLTAGE REGULATOR HARNESS?
 - a. Stop engine.
 - b. Disconnect quick disconnect for lead 566.
 - c. Disconnect voltage regulator harness connector at alternator and voltage regulator.
 - d. Set up multimeter to measure resistance.

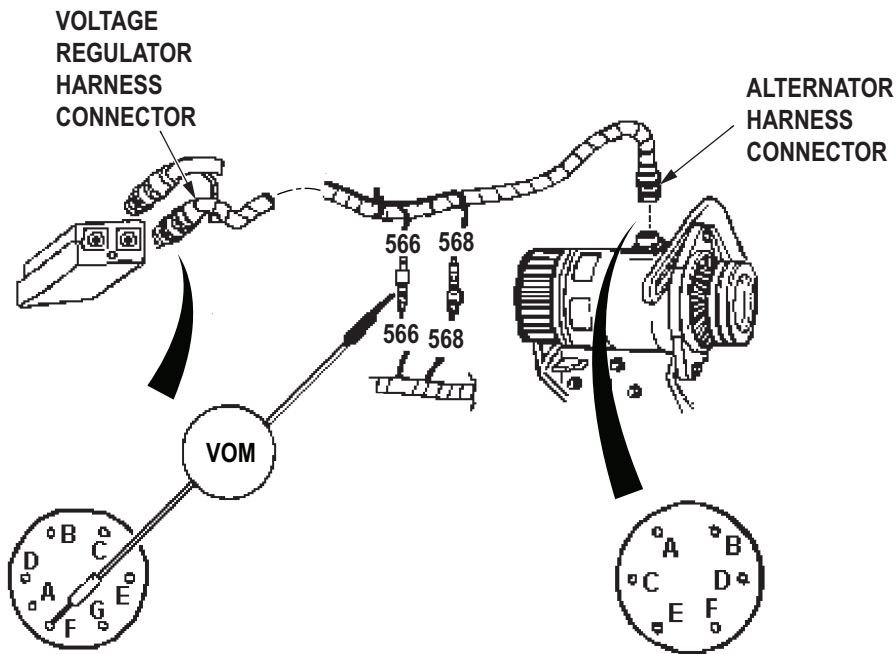

T0167DAA

Figure 3. Voltage Regulator Harness.

- e. Connect multimeter red lead to contact end of lead 566. Refer to point to point schematics.
- f. Connect multimeter black lead to pin F of the voltage regulator harness connector.
- g. Meter reading should be less than 20 ohms.

CONDITION/INDICATION

IS THERE CONTINUITY BETWEEN PIN F OF THE VOLTAGE REGULATOR HARNESS CONNECTOR AND LEAD 566 OF THE VOLTAGE REGULATOR HARNESS?

DECISION

- NO - Replace voltage regulator harness (Volume 5, WP 0792). Go to Step (12) to verify problem is solved.
 YES - Go to Step (4).

NO ALTERNATOR OUTPUT (100 AMP ALTERNATOR) - Continued

STEP

4. IS THERE CONTINUITY BETWEEN PIN D OF THE VOLTAGE REGULATOR HARNESS CONNECTOR AND PIN B OF THE ALTERNATOR HARNESS CONNECTOR?
 - a. Connect multimeter red lead to pin B of the alternator harness connector. Refer to point to point schematics.

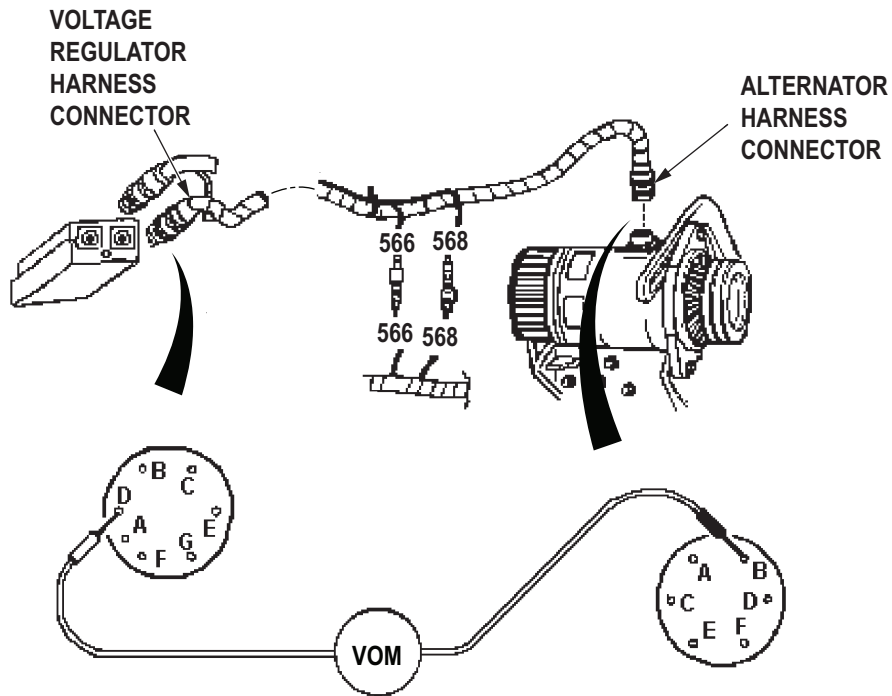

T0168DAA

Figure 4. Voltage Regulator Harness.

- b. Connect multimeter black lead to pin D of the voltage regulator harness connector.
- c. Meter reading should be less than 20 ohms.

CONDITION/INDICATION

IS THERE CONTINUITY BETWEEN PIN D OF THE VOLTAGE REGULATOR HARNESS CONNECTOR AND PIN B OF THE ALTERNATOR HARNESS CONNECTOR?

DECISION

NO - Replace voltage regulator harness (Volume 5, WP 0792). Go to Step (12) to verify problem is solved.
 YES - Go to Step (5).

NO ALTERNATOR OUTPUT (100 AMP ALTERNATOR) - Continued

STEP

5. IS THERE CONTINUITY BETWEEN PIN E OF THE VOLTAGE REGULATOR HARNESS CONNECTOR AND PIN E OF THE ALTERNATOR HARNESS CONNECTOR?
 - a. Connect multimeter red lead to pin E of the alternator harness connector. Refer to point to point schematics.

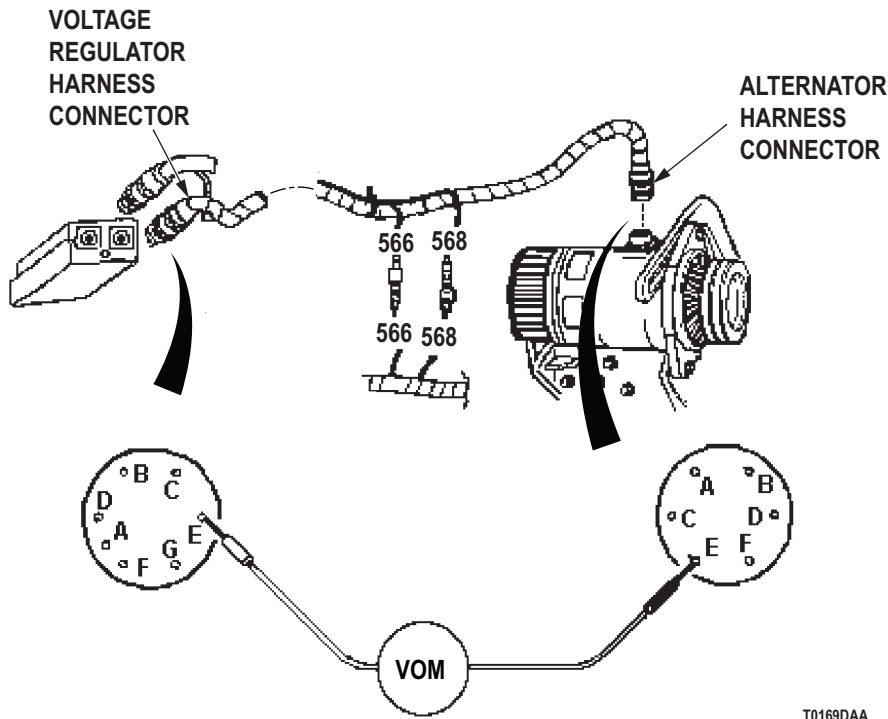

T0169DAA

Figure 5. Voltage Regulator Harness.

- b. Connect multimeter black lead to pin E of the voltage regulator harness connector.
- c. Meter reading should be less than 20 ohms.

CONDITION/INDICATION

IS THERE CONTINUITY BETWEEN PIN E OF THE VOLTAGE REGULATOR HARNESS CONNECTOR AND PIN E OF THE ALTERNATOR HARNESS CONNECTOR?

DECISION

NO - Replace voltage regulator harness (Volume 5, WP 0792). Go to Step (12) to verify problem is solved.
 YES - Go to Step (6).

NO ALTERNATOR OUTPUT (100 AMP ALTERNATOR) - Continued**STEP**

6. IS THERE CONTINUITY BETWEEN PIN C OF THE VOLTAGE REGULATOR HARNESS CONNECTOR AND PIN C OF THE ALTERNATOR HARNESS CONNECTOR?
- a. Connect multimeter red lead to pin C of the alternator harness connector. Refer to point to point schematics.

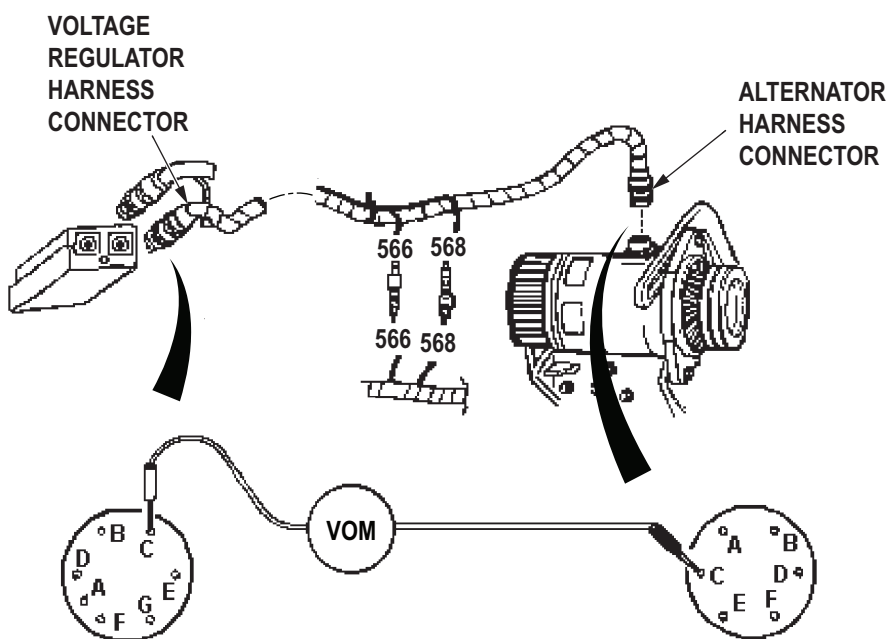

T0170DAA

Figure 6. Voltage Regulator Harness.

- b. Connect multimeter black lead to pin C of the voltage regulator harness connector.
- c. Meter reading should be less than 20 ohms.

CONDITION/INDICATION

IS THERE CONTINUITY BETWEEN PIN C OF THE VOLTAGE REGULATOR HARNESS CONNECTOR AND PIN C OF THE ALTERNATOR HARNESS CONNECTOR?

DECISION

NO - Replace voltage regulator harness (Volume 5, WP 0792). Go to Step (12) to verify problem is solved.
 YES - Go to Step (7).

NO ALTERNATOR OUTPUT (100 AMP ALTERNATOR) - Continued

STEP

7. IS THERE CONTINUITY BETWEEN PIN B OF THE VOLTAGE REGULATOR HARNESS CONNECTOR AND PIN D OF THE ALTERNATOR HARNESS CONNECTOR?
 - a. Connect multimeter red lead to pin D of the alternator harness connector. Refer to point to point schematics.

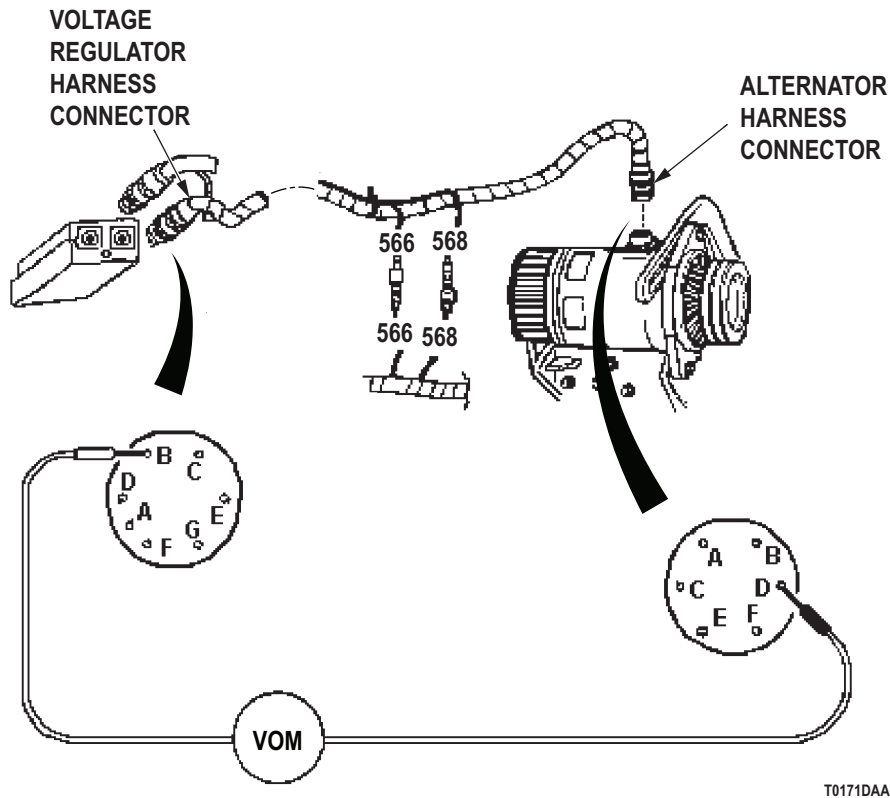

T0171DAA

Figure 7. Voltage Regulator Harness.

- b. Connect multimeter black lead to pin B of the voltage regulator harness connector.
- c. Meter reading should be less than 20 ohms.

CONDITION/INDICATION

IS THERE CONTINUITY BETWEEN PIN B OF THE VOLTAGE REGULATOR HARNESS CONNECTOR AND PIN D OF THE ALTERNATOR HARNESS CONNECTOR?

DECISION

- NO - Replace voltage regulator harness (Volume 5, WP 0792). Go to Step (12) to verify problem is solved.
 YES - Go to Step (8).

NO ALTERNATOR OUTPUT (100 AMP ALTERNATOR) - Continued**STEP**

8. IS THERE CONTINUITY BETWEEN PIN B OF THE VOLTAGE REGULATOR HARNESS CONNECTOR AND LEAD 81 AT STARTER SOLENOID?
 - a. Disconnect quick disconnect for lead 568.
 - b. Disconnect voltage regulator harness connector at voltage regulator.
 - c. Disconnect voltage regulator harness at starter motor and starter solenoid.

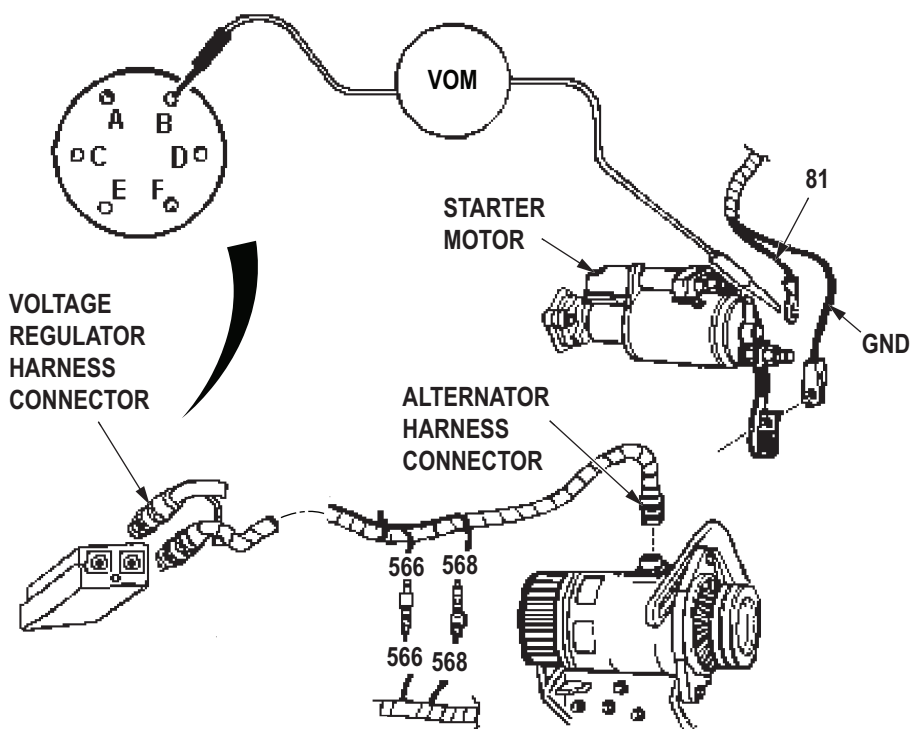

T0172DAA

Figure 8. Voltage Regulator Harness.

- d. Connect multimeter red lead to pin B at voltage regulator harness connector. Refer to point to point schematics.
- e. Connect multimeter black lead to end of lead 81 at starter solenoid.
- f. Meter reading should be less than 20 ohms.

CONDITION/INDICATION

IS THERE CONTINUITY BETWEEN PIN B OF THE VOLTAGE REGULATOR HARNESS CONNECTOR AND LEAD 81 AT STARTER SOLENOID?

DECISION

NO - Replace voltage regulator harness (Volume 5, WP 0792). Go to Step (12) to verify problem is solved.
 YES - Go to Step (9).

NO ALTERNATOR OUTPUT (100 AMP ALTERNATOR) - Continued

STEP

9. IS THERE CONTINUITY BETWEEN PIN A OF THE VOLTAGE REGULATOR HARNESS CONNECTOR AND LEAD 81 AT STARTER SOLENOID?

- a. Connect multimeter red lead to pin A at voltage regulator harness connector. Refer to point to point schematics.

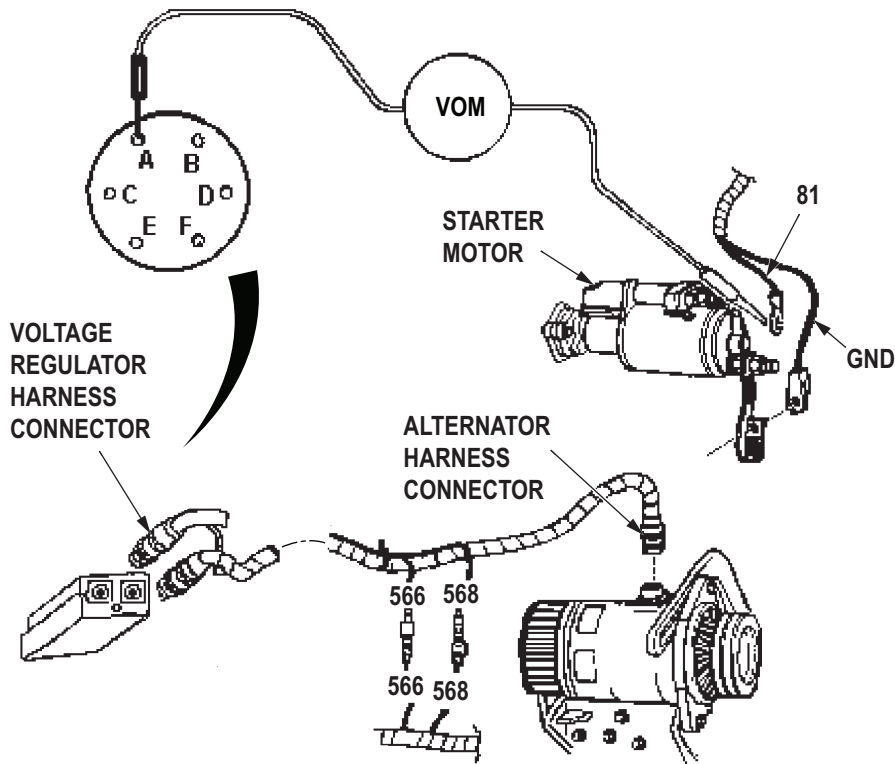

T0173DAA

Figure 9. Voltage Regulator Harness.

- b. Connect multimeter black lead to end of lead 81 at starter solenoid.
- c. Meter reading should be less than 20 ohms.

CONDITION/INDICATION

IS THERE CONTINUITY BETWEEN PIN A OF THE VOLTAGE REGULATOR HARNESS CONNECTOR AND LEAD 81 AT STARTER SOLENOID?

DECISION

NO - Replace voltage regulator harness (Volume 5, WP 0792). Go to Step (12) to verify problem is solved.
 YES - Go to Step (10).

NO ALTERNATOR OUTPUT (100 AMP ALTERNATOR) - Continued

STEP

10. IS THERE CONTINUITY BETWEEN PIN C OF THE VOLTAGE REGULATOR HARNESS CONNECTOR AND LEAD AT STARTER MOTOR?
 - a. Connect multimeter red lead to pin C at voltage regulator harness connector. Refer to point to point schematics.

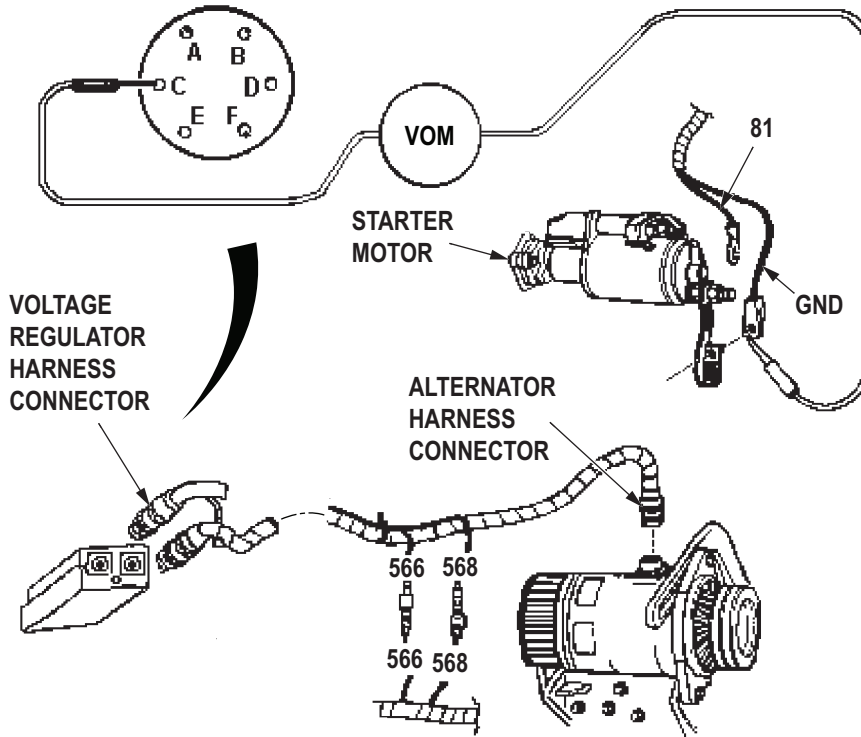

T0174DAA

Figure 10. Voltage Regulator Harness.

- b. Connect multimeter black lead to end of lead to the ground connector at starter motor.
- c. Meter reading should be less than 20 ohms.

CONDITION/INDICATION

IS THERE CONTINUITY BETWEEN PIN C OF THE VOLTAGE REGULATOR HARNESS CONNECTOR AND LEAD AT STARTER MOTOR?

DECISION

NO - Replace voltage regulator harness (Volume 5, WP 0792). Go to Step (12) to verify problem is solved.
 YES - Go to Step (10).

NO ALTERNATOR OUTPUT (100 AMP ALTERNATOR) - Continued

STEP

11. IS THERE CONTINUITY BETWEEN PIN F OF THE VOLTAGE REGULATOR HARNESS CONNECTOR AND LEAD 568?

- a. Connect multimeter red lead to pin F at voltage regulator harness connector. Refer to point to point schematics.

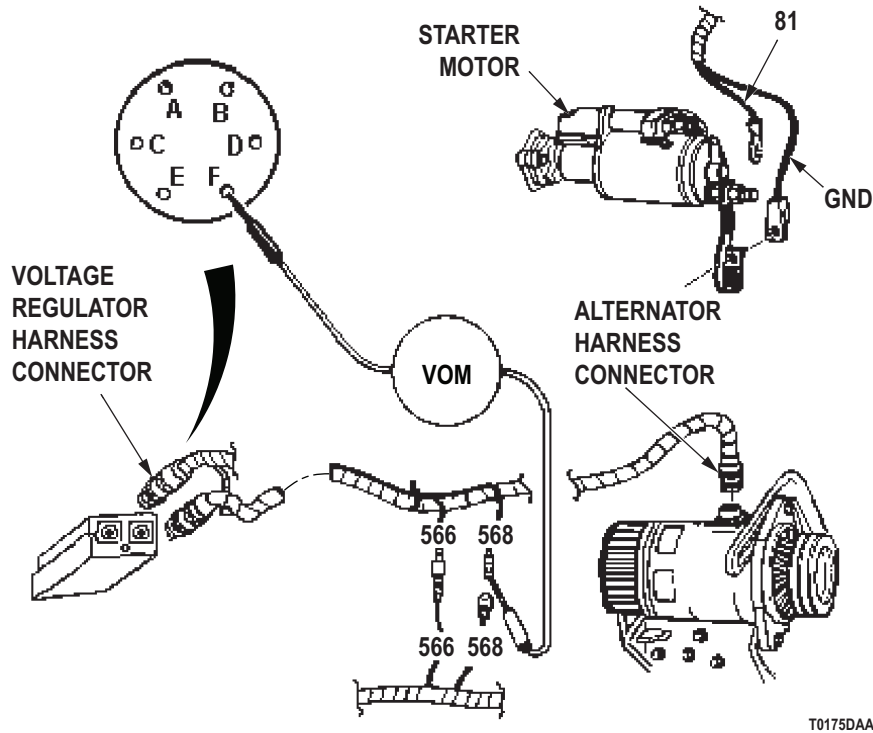

T0175DAA

Figure 11. Voltage Regulator Harness.

- b. Connect multimeter black lead to lead 568.
- c. Meter reading should be less than 20 ohms.

CONDITION/INDICATION

IS THERE CONTINUITY BETWEEN PIN F OF THE VOLTAGE REGULATOR HARNESS CONNECTOR AND LEAD 568?

DECISION

NO - Replace voltage regulator harness (Volume 5, WP 0792). Go to Step (12) to verify problem is solved.
 YES - Notify supervisor. Action may not be possible at this level of maintenance.

NO ALTERNATOR OUTPUT (100 AMP ALTERNATOR) - Continued**STEP**

12. IS YOUR ORIGINAL PROBLEM STILL PRESENT?
- a. Ensure vehicle is returned to normal operating condition.
 - b. Check to see if your original problem still exists.

CONDITION/INDICATION

IS YOUR ORIGINAL PROBLEM STILL PRESENT?

DECISION

YES - Notify supervisor.
NO - Problem fixed.

END OF WORK PACKAGE

FIELD MAINTENANCE
ALTERNATOR OVERCHARGING, BATTERY INDICATOR GAUGE IN RED POSITION

INITIAL SETUP:**Tools and Special Tools**

Tool Kit, General Mechanic's: Automotive
(Volume 5, WP 0826, Table 1, Item 56)
Multimeter
(Volume 5, WP 0826, Table 1, Item 34)
Test Set, Electronic Systems
(Volume 5, WP 0826, Table 1, Item 51)

References (cont.)

WP 0108
Volume 2, WP 0300
Volume 2, WP 0301
Volume 5, WP 0780

Personnel Required

(2)

Equipment Condition

Vehicle parked and engine shut down.
(TM 9-2320-272-10)

References

Point to Point Schematics

TROUBLESHOOTING PROCEDURE**ALTERNATOR OVERCHARGING, BATTERY INDICATOR GAUGE IN RED POSITION****NOTE**

Conduct these malfunction tests if the battery indicator gauge is in red position. This procedure will check the alternator and the gauge circuitry.

ALTERNATOR OVERCHARGING, BATTERY INDICATOR GAUGE IN RED POSITION - Continued**STEP**

1. IS THE ALTERNATOR OUTPUT VOLTAGE EXCESSIVE?
 - a. Verify engine is stopped.
 - b. Set up multimeter to measure VDC.

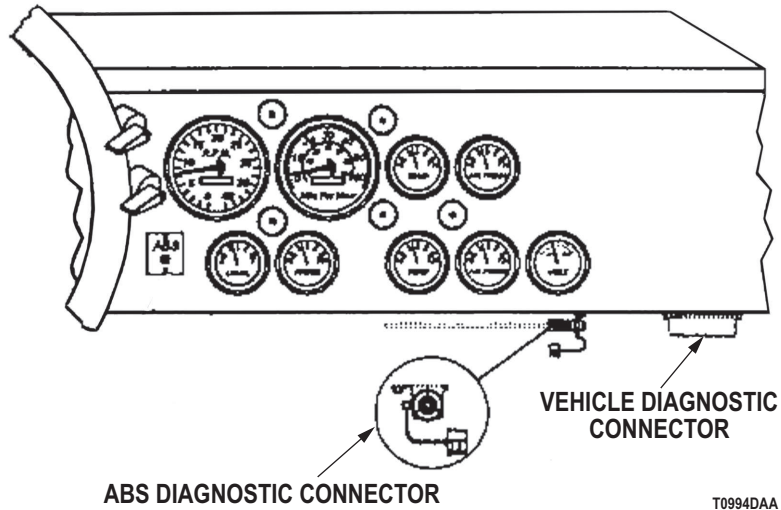

Figure 1. DCA Connector.

- c. Connect multimeter red lead to vehicle DCA connector, terminal N. Refer to point to point schematics.
- d. Connect multimeter black lead to vehicle DCA connector, terminal P.
- e. Start engine and run at fast idle.
- f. Meter reading should be less than 29.5 VDC.

CONDITION/INDICATION

IS THE ALTERNATOR OUTPUT VOLTAGE EXCESSIVE?

DECISION

- NO - Go to Step (3).
 YES - Go to Step (2).

ALTERNATOR OVERCHARGING, BATTERY INDICATOR GAUGE IN RED POSITION - Continued**STEP**

2. IS A 100 AMP ALTERNATOR INSTALLED?
 - a. Stop engine.

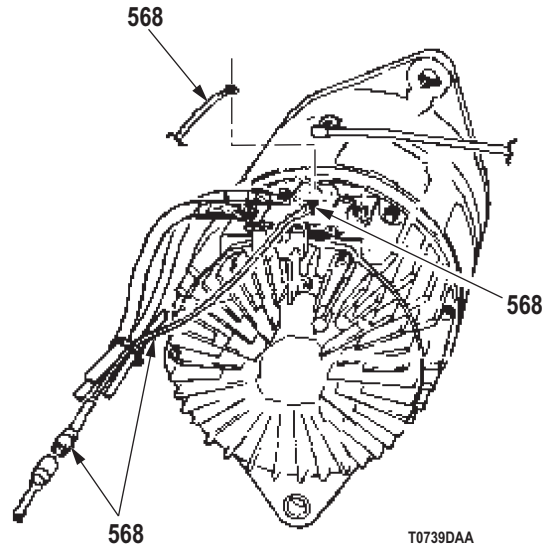

Figure 2. Alternator Electrical Wiring.

NOTE

100 amp alternators are equipped with a quick disconnect connector.

- b. Determine which alternator is in your vehicle.

CONDITION/INDICATION

IS A 100 AMP ALTERNATOR INSTALLED?

DECISION

YES - Replace 100 amp alternator (Volume 5, WP 0780). Go to Step (6) to verify problem is solved.

NO - Replace 60 amp alternator M939/A1 (Volume 2, WP 0300), M939A2 (Volume 2, WP 0301). Go to Step (6) to verify problem is solved.

ALTERNATOR OVERCHARGING, BATTERY INDICATOR GAUGE IN RED POSITION - Continued**STEP**

3. IS THE ALTERNATOR OVERHEATING?
 - a. Start engine and run for approximately 10 minutes.
 - b. Stop engine.

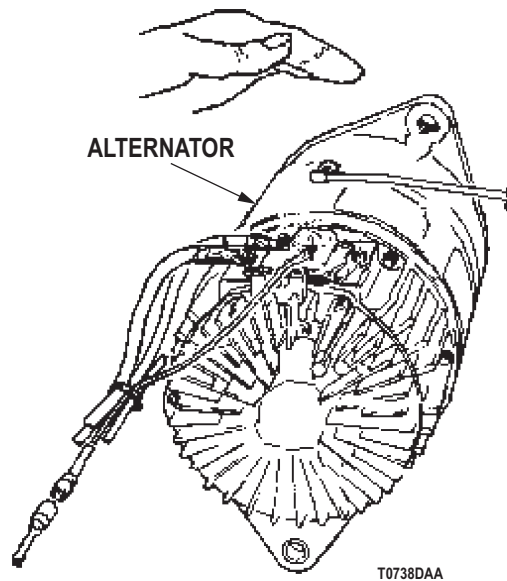

Figure 3. Alternator.

- c. Check alternator for high temperature by holding hand NEAR alternator.

CONDITION/INDICATION

IS THE ALTERNATOR OVERHEATING?

DECISION

YES - Go to Step (4).

NO - Perform Battery/Alternator Gauge Inoperative troubleshooting (WP 0108).

ALTERNATOR OVERCHARGING, BATTERY INDICATOR GAUGE IN RED POSITION - Continued**STEP**

4. DOES THE GAUGE READ HIGH AND THE ALTERNATOR OVERHEAT A SECOND TIME?
 - a. Disconnect wire 568 at alternator. Refer to point to point schematics.

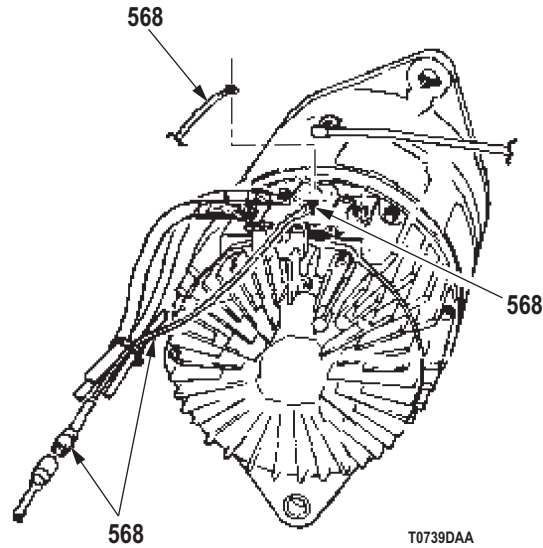

Figure 4. Alternator Wire 568.

- b. Allow alternator to cool.
- c. Reconnect wire 568.
- d. Start engine and run for approximately 10 minutes.
- e. Check indicator gauge.
- f. Check alternator for high temperature by holding hand NEAR alternator.

CONDITION/INDICATION

DOES THE GAUGE READ HIGH AND THE ALTERNATOR OVERHEAT A SECOND TIME?

DECISION

YES - Go to Step (5).

NO - Notify supervisor. Action may not be possible at this level of maintenance.

ALTERNATOR OVERCHARGING, BATTERY INDICATOR GAUGE IN RED POSITION - Continued**STEP**

5. IS A 100 AMP ALTERNATOR INSTALLED?

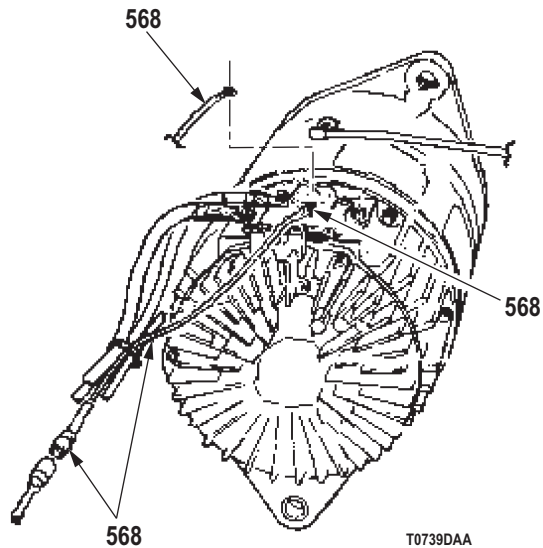

Figure 5. Alternator Electrical Wiring.

NOTE

100 amp alternators are equipped with a quick disconnect connector.
Determine which alternator is in your vehicle.

CONDITION/INDICATION

IS A 100 AMP ALTERNATOR INSTALLED?

DECISION

YES - Replace 100 amp alternator (Volume 5, WP 0780). Go to Step (6) to verify problem is solved.
NO - Replace 60 amp alternator M939/A1 (Volume 2, WP 0300), M939A2 (Volume 2, WP 0301). Go to Step (6) to verify problem is solved.

ALTERNATOR OVERCHARGING, BATTERY INDICATOR GAUGE IN RED POSITION - Continued**STEP**

6. IS YOUR ORIGINAL PROBLEM STILL PRESENT?
 - a. Ensure vehicle is returned to normal operating condition.
 - b. Check to see if your original problem still exists.

CONDITION/INDICATION

IS YOUR ORIGINAL PROBLEM STILL PRESENT?

DECISION

YES - Notify supervisor.
NO - Problem fixed.

END OF WORK PACKAGE

**FIELD MAINTENANCE
HEADLAMP (ONE SIDE) INOPERATIVE**

INITIAL SETUP:**Tools and Special Tools**

Tool Kit, General Mechanic's: Automotive
(Volume 5, WP 0826, Table 1, Item 56)
Multimeter
(Volume 5, WP 0826, Table 1, Item 34)
Test Set, Electronic Systems
(Volume 5, WP 0826, Table 1, Item 51)

References (cont.)

Volume 2, WP 0325
Volume 3, WP 0352

Equipment Condition

Vehicle parked and engine shut down.
(TM 9-2320-272-10)

Personnel Required

(2)

References

Point to Point Schematics

TROUBLESHOOTING PROCEDURE**HEADLAMP (ONE SIDE) INOPERATIVE****NOTE**

Conduct these malfunction tests if headlamp on one side is inoperative. This procedure will check for defective headlamp bulb, wiring harness, or headlamp assembly.

HEADLAMP (ONE SIDE) INOPERATIVE - Continued**STEP****1. ARE BULBS IN GOOD CONDITION?**

- a. Replace non-operating bulb with one known to be operative (Volume 2, WP 0325).

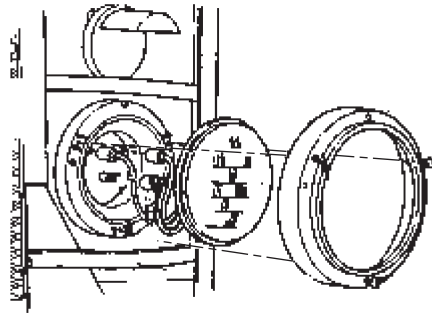

T0751DAA

Figure 1. Headlamp Bulb.

- b. Place battery switch to ON position.
- c. Place lighting switch to SERVICE DRIVE position.
- d. Press beam select switch to HIGH BEAM and LOW BEAM position.

NOTE

If headlamp operates, bulb was faulty.

- e. Check if headlamp operates in low and high beam.

CONDITION/INDICATION

ARE BULBS IN GOOD CONDITION?

DECISION

- NO - Go to Step (3) to verify problem is solved.
YES - Go to Step (2).

HEADLAMP (ONE SIDE) INOPERATIVE - Continued**STEP**

2. IS THERE BATTERY VOLTAGE AT HEADLAMP CONNECTOR?
 - a. Place battery switch to OFF position.

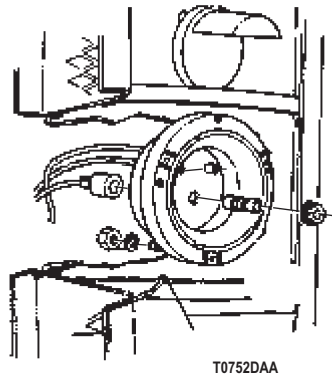

Figure 2. Headlamp Connectors.

- b. Disconnect circuit 18 and 17 wire at inoperative headlamp.
- c. Make sure wire connector contacts are clean.
- d. Place battery switch to ON position.
- e. Place lighting switch to SERVICE DRIVE position and press beam select switch to LOW BEAM.
- f. Set up multimeter to measure VDC.
- g. Connect multimeter red lead to circuit 18 wire. Refer to point to point schematics.
- h. Connect multimeter black lead to good ground.
- i. Meter reading should be greater than 18 VDC. Note reading.
- j. Press beam select switch to HIGH BEAM.
- k. Connect multimeter red lead to circuit 17 wire.
- l. Connect multimeter black lead to good ground.
- m. Meter reading should be greater than 18 VDC. Note reading.

CONDITION/INDICATION

IS THERE BATTERY VOLTAGE AT HEADLAMP CONNECTOR?

DECISION

NO - Repair or replace loose or corroded connections and wiring from headlamp to beam select switch (Volume 3, WP 0352). Go to Step (3) to verify problem is solved.

YES - Replace defective headlamp (Volume 2, WP 0325). Go to Step (3) to verify problem is solved.

HEADLAMP (ONE SIDE) INOPERATIVE - Continued**STEP**

3. IS YOUR ORIGINAL PROBLEM STILL PRESENT?
 - a. Ensure vehicle is returned to normal operating condition.
 - b. Check to see if your original problem still exists.

CONDITION/INDICATION

IS YOUR ORIGINAL PROBLEM STILL PRESENT?

DECISION

YES - Notify supervisor.
NO - Problem fixed.

END OF WORK PACKAGE

**FIELD MAINTENANCE
HEADLAMP (BOTH SIDE) INOPERATIVE**

INITIAL SETUP:**Tools and Special Tools**

Tool Kit, General Mechanic's: Automotive
(Volume 5, WP 0826, Table 1, Item 56)
Multimeter
(Volume 5, WP 0826, Table 1, Item 34)
Test Set, Electronic Systems
(Volume 5, WP 0826, Table 1, Item 51)

References (cont.)

Volume 2, WP 0315
Volume 2, WP 0316
Volume 3, WP 0352

Equipment Condition

Vehicle parked and engine shut down.
(TM 9-2320-272-10)

Personnel Required

(2)

References

Point to Point Schematics

TROUBLESHOOTING PROCEDURE**HEADLAMP (BOTH SIDE) INOPERATIVE****NOTE**

Conduct these malfunction tests if headlamps on both sides are inoperative. This procedure will check for defective wiring harness or connector, corroded parts or defective switch.

HEADLAMP (BOTH SIDE) INOPERATIVE - Continued**STEP**

1. IS HEADLAMP WIRING HARNESS IN GOOD CONDITION?
 - a. Place battery switch to OFF position.

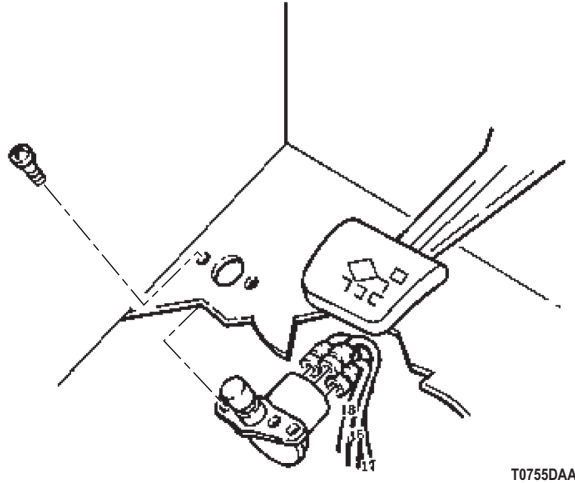

Figure 1. Beam Select Switch.

- b. Disconnect circuit 18 and 17 wire at beam selector switch.
- c. Place battery switch to ON position.
- d. Place lighting switch to SERVICE DRIVE position and press beam select switch to LOW BEAM.
- e. Set up multimeter to measure VDC.
- f. Connect multimeter red lead to circuit 18 terminal on switch. Refer to point to point schematics.
- g. Connect multimeter black lead to good ground.

NOTE

If meter reading is greater than 18 VDC for both measurements, headlamp wiring harness is faulty.

- h. Meter reading should be greater than 18 VDC. Note reading.
- i. Press beam select switch to HIGH BEAM.
- j. Connect multimeter red lead to circuit 17 terminal on switch.
- k. Connect multimeter black lead to good ground.
- l. Meter reading should be greater than 18 VDC. Note reading.

CONDITION/INDICATION

IS HEADLAMP WIRING HARNESS IN GOOD CONDITION?

HEADLAMP (BOTH SIDE) INOPERATIVE - Continued**DECISION**

NO - Repair or replace loose or corroded connections and wiring from headlamps to beam select switch (Volume 3, WP 0352). Go to Step (6) to verify problem is solved.

YES - Go to Step (2).

STEP**2. IS THERE BATTERY VOLTAGE AT CIRCUIT 16 WIRE?**

- a. Place battery switch to OFF position.

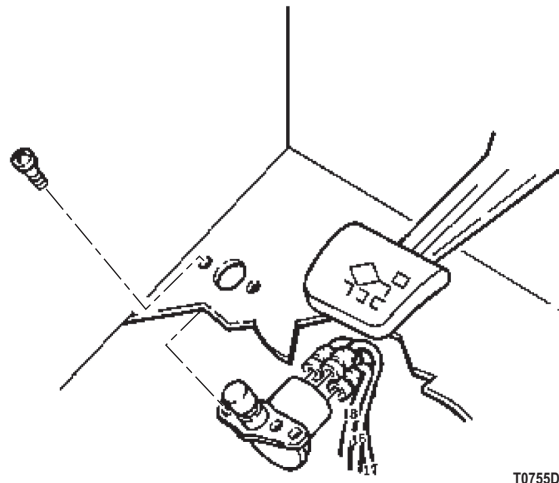

Figure 2. Beam Select Switch.

- b. Disconnect circuit 16 wire from beam selector switch.
- c. Inspect and make sure circuit wire 16 is in good condition.
- d. Place battery switch to ON position.
- e. Place lighting switch to SERVICE DRIVE position.
- f. Connect multimeter red lead to circuit 16 wire (not the switch terminal). Refer to point to point schematics.
- g. Connect multimeter black lead to good ground.
- h. Meter reading should be greater than 18 VDC.

CONDITION/INDICATION

IS THERE BATTERY VOLTAGE AT CIRCUIT 16 WIRE?

DECISION

NO - Go to Step (3).

YES - Replace beam selector switch (Volume 2, WP 0316). Go to Step (6) to verify problem is solved.

HEADLAMP (BOTH SIDE) INOPERATIVE - Continued**STEP**

3. IS THERE BATTERY VOLTAGE AT MAIN LIGHT SWITCH HARNESS CONNECTOR?
 - a. Place battery switch to OFF position.

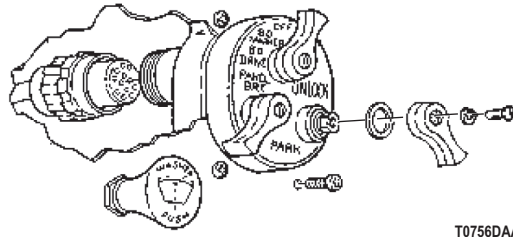

Figure 3. Main Lighting Switch.

- b. Remove lighting switch from instrument panel and disconnect harness connector (Volume 2, WP 0315).
- c. Place battery switch to ON position.
- d. Connect multimeter red lead to connector socket pin F. Refer to point to point schematics.
- e. Connect multimeter black lead to good ground.
- f. Meter reading should be greater than 18 VDC.

CONDITION/INDICATION

IS THERE BATTERY VOLTAGE AT MAIN LIGHT SWITCH HARNESS CONNECTOR?

DECISION

- NO - Go to Step (4).
YES - Go to Step (5).

HEADLAMP (BOTH SIDE) INOPERATIVE - Continued**STEP**

4. IS WIRING HARNESS IN GOOD CONDITION?
 - a. Place battery switch to OFF position.

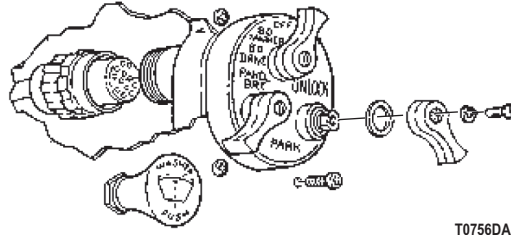

Figure 4. Main Lighting Switch Connector.

- b. Visually check wiring harness for loose connections or broken wiring. Refer to point to point schematic.

CONDITION/INDICATION

IS WIRING HARNESS IN GOOD CONDITION?

DECISION

NO - Repair or replace broken wire (Volume 3, WP 0352). Go to Step (6) to verify problem is solved.
YES - Notify supervisor. Action may not be possible at this level of maintenance.

HEADLAMP (BOTH SIDE) INOPERATIVE - Continued**STEP**

5. IS MAIN LIGHT SWITCH OPERATING PROPERLY?
 - a. Place battery switch to OFF position.

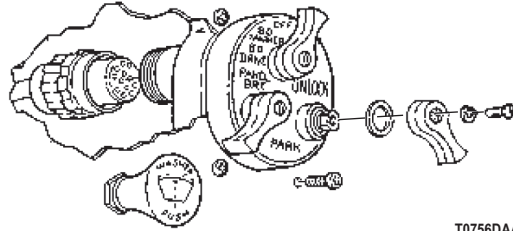

Figure 5. Main Lighting Switch Connector.

- b. Connect jumper cable from socket pin F to socket pin M.
 - c. Place battery switch to ON position.

NOTE

If headlamps light, lighting switch is not operating properly.

- d. Look for lighted headlamps.

CONDITION/INDICATION

IS MAIN LIGHT SWITCH OPERATING PROPERLY?

DECISION

YES - Repair or replace circuit wire 16 (Volume 3, WP 0352). Go to Step (6) to verify problem is solved.
 NO - Replace defective main light switch (Volume 2, WP 0315). Go to Step (6) to verify problem is solved.

STEP

6. IS YOUR ORIGINAL LIGHTING PROBLEM STILL PRESENT?
 - a. Ensure vehicle is returned to normal operating condition.
 - b. Check to see if your original lighting problem still exists.

CONDITION/INDICATION

IS YOUR ORIGINAL LIGHTING PROBLEM STILL PRESENT?

DECISION

YES - Notify supervisor.
 NO - Problem fixed.

END OF WORK PACKAGE

FIELD MAINTENANCE
BLACKOUT DRIVE OR BLACKOUT MARKER LIGHT INOPERATIVE

INITIAL SETUP:**Tools and Special Tools**

Tool Kit, General Mechanic's: Automotive
(Volume 5, WP 0826, Table 1, Item 56)
Multimeter
(Volume 5, WP 0826, Table 1, Item 34)
Test Set, Electronic Systems
(Volume 5, WP 0826, Table 1, Item 51)

References (cont.)

Volume 2, WP 0315
Volume 2, WP 0326
Volume 2, WP 0327
Volume 3, WP 0352

Personnel Required

(2)

Equipment Condition

Vehicle parked and engine shut down.
(TM 9-2320-272-10)

References

Point to Point Schematics

TROUBLESHOOTING PROCEDURE**BLACKOUT DRIVE OR BLACKOUT MARKER LIGHT INOPERATIVE****NOTE**

Conduct these malfunction tests if blackout drive or blackout marker light is inoperative. This procedure will check for defective bulbs, defective wiring harness or connector, corroded parts, or defective switch.

BLACKOUT DRIVE OR BLACKOUT MARKER LIGHT INOPERATIVE - Continued**STEP****1. ARE BULBS IN GOOD CONDITION?***Figure 1. Light Bulbs.*

- a. If blackout drive light is inoperative, replace blackout light bulb with one known to be operative (Volume 2, WP 0326).
- b. If front blackout light is inoperative, replace blackout light bulb with one known to be operative (Volume 2, WP 0327).
- c. If rear blackout light is inoperative, replace blackout light bulb with one known to be operative (Volume 2, WP 0327).

NOTE

If all blackout lights operates, bulb was faulty.

- d. Place battery switch to ON position.
- e. Place lighting switch to B.O. DRIVE position.
- f. Check if all blackout lights operates.

CONDITION/INDICATION

ARE BULBS IN GOOD CONDITION?

DECISION

NO - Go to Step (8) to verify problem is solved.
 YES - Go to Step (2).

STEP**2. ARE SOCKETS AND TERMINALS CLEAN AND IN GOOD CONDITION?**

- a. Place battery switch to OFF position.

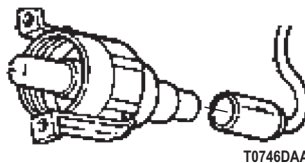
*Figure 2. Light Socket.*

- b. Visually check for corrosion or dirt in sockets or on terminals. Refer to point to point schematic.
- c. Clean corroded connections.

BLACKOUT DRIVE OR BLACKOUT MARKER LIGHT INOPERATIVE - Continued**CONDITION/INDICATION**

ARE SOCKETS AND TERMINALS CLEAN AND IN GOOD CONDITION?

DECISION

NO - Blackout drive light defective. Replace defective blackout drive light (Volume 2, WP 0326). Go to Step (8) to verify problem is solved.

NO - Composite light defective. Replace defective composite light (Volume 2, WP 0327). Go to Step (8) to verify problem is solved.

YES - Go to Step (3).

STEP

3. ARE LAMP HOLDERS IN GOOD OPERATING CONDITION?

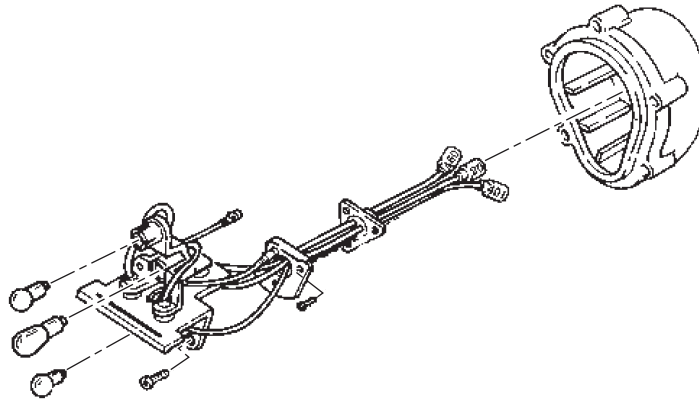

T0747DAA

Figure 3. Lamp Holder.

Visually check lamp holders for loose and broken wire terminals. Refer to point to point schematic.

CONDITION/INDICATION

ARE LAMP HOLDERS IN GOOD OPERATING CONDITION?

DECISION

NO - Repair or replace broken wire (Volume 3, WP 0352). Go to Step (8) to verify problem is solved.

YES - Go to Step (4).

BLACKOUT DRIVE OR BLACKOUT MARKER LIGHT INOPERATIVE - Continued**STEP**

4. IS THERE BATTERY VOLTAGE AT NON-OPERATING BLACKOUT LAMP CONNECTOR?
- a. Place battery switch to OFF position.

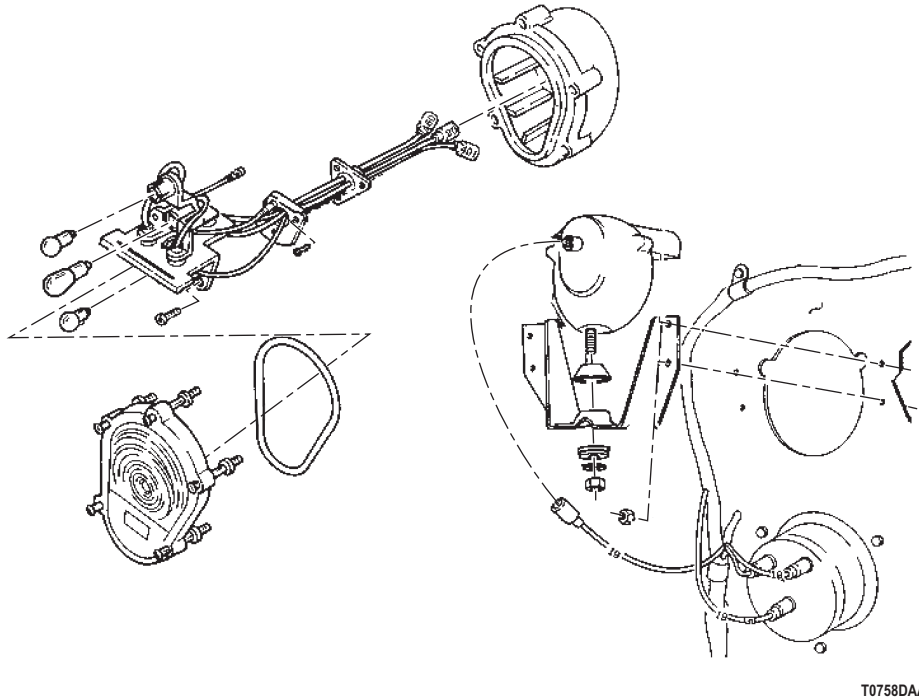

T0758DAA

Figure 4. Blackout Light Assemblies.

- b. Disconnect circuit 19 wire from non-operating blackout drive light.
- c. Disconnect circuit 20 wire from non-operating left and right front composite lights.
- d. Disconnect circuit 24 wire from non-operating left and right rear composite lights.
- e. Place battery switch to ON position.
- f. Place lighting switch to B.O. DRIVE position.
- g. Set up multimeter to measure VDC.

NOTE

Perform the following Steps at non-operating blackout light.

- h. Connect multimeter red lead to disconnected wire. Refer to point to point schematics.
- i. Connect multimeter black lead to good ground.
- j. Meter reading should be greater than 18 VDC for each reading. Note reading.

CONDITION/INDICATION

IS THERE BATTERY VOLTAGE AT NON-OPERATING BLACKOUT LAMP CONNECTOR?

BLACKOUT DRIVE OR BLACKOUT MARKER LIGHT INOPERATIVE - Continued**DECISION**

YES - Battery voltage at circuit 19 wire. Replace non-operating blackout drive light (Volume 2, WP 0326). Go to Step (8) to verify problem is solved.

YES - Battery voltage at circuit 20 wire. Replace non-operating front composite light (Volume 2, WP 0327). Go to Step (8) to verify problem is solved.

YES - Battery voltage at circuit 24 wire. Replace non-operating rear composite light (Volume 2, WP 0327). Go to Step (8) to verify problem is solved.

NO - Go to Step (5).

STEP

5. IS THERE BATTERY VOLTAGE AT MAIN LIGHT SWITCH HARNESS CONNECTOR?

- a. Place battery switch to OFF position.

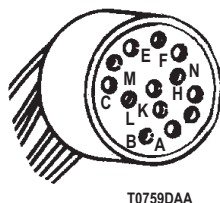

T0759DAA

Figure 5. Main Lighting Switch Connector.

- b. Remove lighting switch from instrument panel and disconnect harness connector (Volume 2, WP 0315).
- c. Place battery switch to ON position.
- d. Connect multimeter red lead to connector socket pin F. Refer to point to point schematics.
- e. Connect multimeter black lead to good ground.
- f. Meter reading should be greater than 18 VDC.

CONDITION/INDICATION

IS THERE BATTERY VOLTAGE AT MAIN LIGHT SWITCH HARNESS CONNECTOR?

DECISION

NO - Go to Step (6).

YES - Go to Step (7).

BLACKOUT DRIVE OR BLACKOUT MARKER LIGHT INOPERATIVE - Continued**STEP**

6. IS WIRING HARNESS IN GOOD CONDITION?
- a. Place battery switch to OFF position.

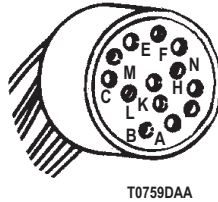

Figure 6. Main Lighting Switch Connector.

- b. Visually check wiring harness for loose connections or broken wiring. Refer to point to point schematic.

CONDITION/INDICATION

IS WIRING HARNESS IN GOOD CONDITION?

DECISION

NO - Repair or replace broken wire (Volume 3, WP 0352). Go to Step (8) to verify problem is solved.
YES - Notify supervisor. Action may not be possible at this level of maintenance.

BLACKOUT DRIVE OR BLACKOUT MARKER LIGHT INOPERATIVE - Continued**STEP**

7. IS MAIN LIGHT SWITCH OPERATING PROPERLY?
- a. Place battery switch to OFF position.

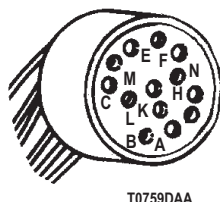

Figure 7. Main Lighting Switch Connector.

- b. Connect jumper cable from socket pin F to socket pin D. Refer to point to point schematics.
- c. Place battery switch to ON position.

NOTE

If non-operating blackout drive light illuminates, lighting switch is not operating properly.

- d. Look for lighted B.O. driving light.
- e. Connect jumper cable from socket pin F to socket pin E.

NOTE

If non-operating blackout lights illuminates, lighting switch is not operating properly.

- f. Look for lighted front and rear B.O. lights.

CONDITION/INDICATION

IS MAIN LIGHT SWITCH OPERATING PROPERLY?

DECISION

NO - Replace defective main light switch (Volume 2, WP 0315). Go to Step (8) to verify problem is solved.

YES - Repair or replace wiring from main light switch to non-operating lamp (Volume 3, WP 0352). Go to Step (8) to verify problem is solved.

BLACKOUT DRIVE OR BLACKOUT MARKER LIGHT INOPERATIVE - Continued**STEP**

8. IS YOUR ORIGINAL BLACKOUT DRIVE OR MARKER LIGHT PROBLEM STILL PRESENT?
 - a. Ensure vehicle is returned to normal operating condition.
 - b. Check to see if your original blackout drive or marker light problem still exists.

CONDITION/INDICATION

IS YOUR ORIGINAL BLACKOUT DRIVE OR MARKER LIGHT PROBLEM STILL PRESENT?

DECISION

YES - Notify supervisor.
NO - Problem fixed.

END OF WORK PACKAGE

**FIELD MAINTENANCE
STOPLIGHT INOPERATIVE (SERVICE OR BLACKOUT)**

INITIAL SETUP:**Tools and Special Tools**

Tool Kit, General Mechanic's: Automotive
(Volume 5, WP 0826, Table 1, Item 56)
Multimeter
(Volume 5, WP 0826, Table 1, Item 34)
Test Set, Electronic Systems
(Volume 5, WP 0826, Table 1, Item 51)

References (cont.)

Volume 2, WP 0315
Volume 2, WP 0327
Volume 2, WP 0335
Volume 3, WP 0352

Personnel Required

(2)

Equipment Condition

Vehicle parked and engine shut down.
(TM 9-2320-272-10)

References

Point to Point Schematics

TROUBLESHOOTING PROCEDURE**STOPLIGHT INOPERATIVE (SERVICE OR BLACKOUT)****NOTE**

Conduct these malfunction tests if stoplight is inoperative. This procedure will check for battery voltage at stoplight switch, defective bulb, faulty wiring, damaged contacts, faulty stoplight switch, and faulty main lighting switch.

STOPLIGHT INOPERATIVE (SERVICE OR BLACKOUT) - Continued**STEP****1. ARE BULBS IN GOOD CONDITION?**

- a. Replace non-operating stoplight bulb with one known to be operative (Volume 2, WP 0327).



T1024DAA

Figure 1. Light Bulbs.

- b. Start engine and run to build air supply to normal operating pressure.

NOTE

- For stoplight circuit test, air pressure must be maintained at operating pressure and brake pedal must be depressed.
- If all stoplights operates, bulb was faulty.

- c. Press brake pedal.
d. Check if all stoplights operates.

CONDITION/INDICATION

ARE BULBS IN GOOD CONDITION?

DECISION

NO - Go to Step (12) to verify problem is solved.
YES - Go to Step (2).

STEP**2. ARE SOCKETS AND TERMINALS CLEAN AND IN GOOD CONDITION?**

- a. Place battery switch to OFF position.

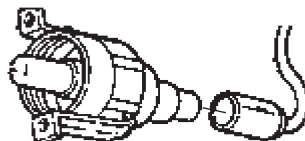

T1025DAA

Figure 2. Light Socket.

STOPLIGHT INOPERATIVE (SERVICE OR BLACKOUT) - Continued

- b. Visually check for corrosion or dirt in sockets or on terminals. Refer to point to point schematic.
- c. Clean corroded connections.

CONDITION/INDICATION

ARE SOCKETS AND TERMINALS CLEAN AND IN GOOD CONDITION?

DECISION

NO - Replace defective composite light (Volume 2, WP 0327). Go to Step (12) to verify problem is solved.
 YES - Go to Step (3).

STEP

- 3. ARE LAMP HOLDERS IN GOOD OPERATING CONDITION?

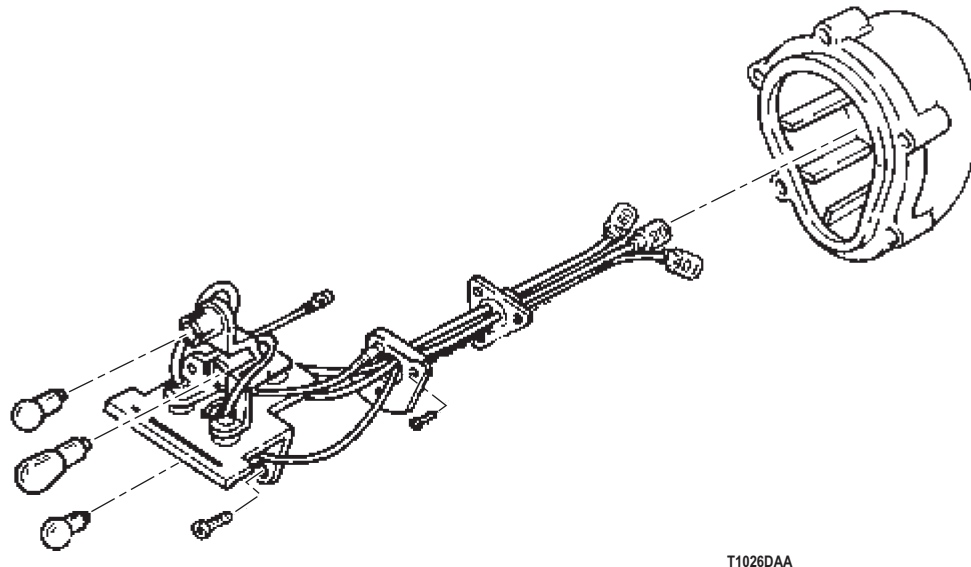

T1026DAA

Figure 3. Lamp Holder.

Visually check lamp holders for loose and broken wire terminals. Refer to point to point schematic.

CONDITION/INDICATION

ARE LAMP HOLDERS IN GOOD OPERATING CONDITION?

DECISION

NO - Repair or replace broken wire (Volume 3, WP 0352). Go to Step (12) to verify problem is solved.
 YES - Go to Step (4).

STOPLIGHT INOPERATIVE (SERVICE OR BLACKOUT) - Continued**STEP****4. IS THERE VOLTAGE AT STOPLIGHT SWITCH?**

- a. Place battery switch to OFF position.

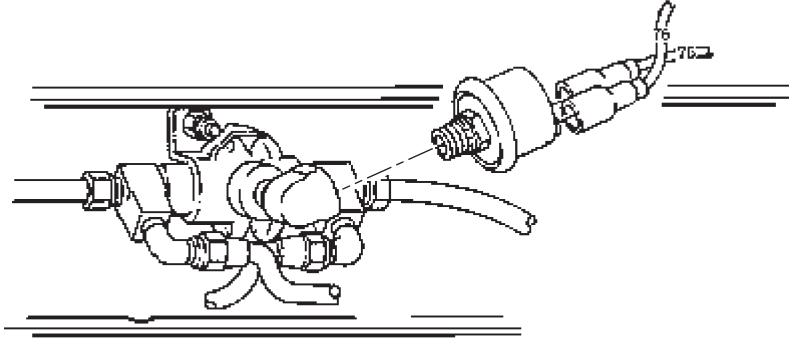

T0762DAA

Figure 4. Stoplight Switch.

- b. Disconnect both circuit 75 wires at stoplight switch.
- c. Place battery switch to ON position.
- d. Set up multimeter to measure VDC.
- e. Connect multimeter black lead to good ground.
- f. Connect multimeter red lead to both circuit 75 wires, one at a time. Refer to point to point schematics.
- g. Meter reading should be greater than 18 VDC for at one of the wires. Note reading.

CONDITION/INDICATION

IS THERE VOLTAGE AT STOPLIGHT SWITCH?

DECISION

- NO - Go to Step (5).
 YES - Go to Step (8).

STOPLIGHT INOPERATIVE (SERVICE OR BLACKOUT) - Continued**STEP**

5. IS THERE BATTERY VOLTAGE AT MAIN LIGHT SWITCH HARNESS CONNECTOR?
 - a. Place battery switch to OFF position.

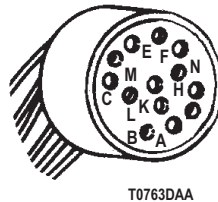

Figure 5. Main Lighting Switch Connector.

- b. Remove lighting switch from instrument panel and disconnect harness connector (Volume 2, WP 0315).
- c. Place battery switch to ON position.
- d. Connect multimeter red lead to connector socket pin F. Refer to point to point schematics.
- e. Connect multimeter black lead to good ground.
- f. Meter reading should be greater than 18 VDC.

CONDITION/INDICATION

IS THERE BATTERY VOLTAGE AT MAIN LIGHT SWITCH HARNESS CONNECTOR?

DECISION

- NO - Go to Step (6).
YES - Go to Step (7).

STOPLIGHT INOPERATIVE (SERVICE OR BLACKOUT) - Continued**STEP**

6. IS WIRING HARNESS IN GOOD CONDITION?
- a. Place battery switch to OFF position.

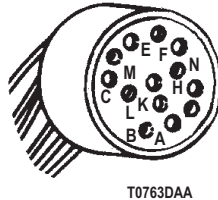

Figure 6. Main Lighting Switch Connector.

- b. Visually check wiring harness for loose connections or broken wiring. Refer to point to point schematic.

CONDITION/INDICATION

IS WIRING HARNESS IN GOOD CONDITION?

DECISION

NO - Repair or replace broken wire (Volume 3, WP 0352). Go to Step (8) to verify problem is solved.
YES - Notify supervisor. Action may not be possible at this level of maintenance.

STOPLIGHT INOPERATIVE (SERVICE OR BLACKOUT) - Continued**STEP**

7. IS THERE CONTINUITY ACROSS CIRCUIT WIRE 75?
- Place battery switch to OFF position.
 - Setup multimeter to measure ohms.

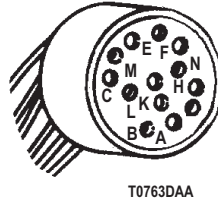

Figure 7. Main Lighting Switch Connector.

- Connect jumper cable between lighting system harness connector socket pins A and K. Refer to point to point schematic.
- Connect multimeter red lead to circuit wire 75 at stop switch.
- Connect multimeter black lead to other circuit wire 75 at stop switch.
- Meter reading should be less than 20 ohms.

CONDITION/INDICATION

IS THERE CONTINUITY ACROSS CIRCUIT WIRE 75?

DECISION

NO - Repair or replace broken circuit wire 75 (Volume 3, WP 0352). Go to Step (12) to verify problem is solved.
YES - Replace defective main light switch (Volume 2, WP 0315). Go to Step (12) to verify problem is solved.

STOPLIGHT INOPERATIVE (SERVICE OR BLACKOUT) - Continued**STEP****8. IS STOPLIGHT SWITCH OPERATING PROPERLY?**

- a. Connect circuit 75 wire where battery voltage was present to stoplight switch terminal.

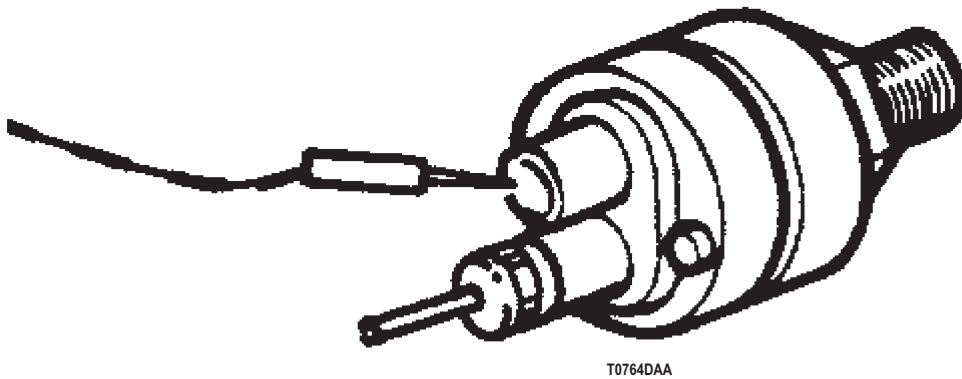

Figure 8. Stoplight Switch Test.

- b. Connect multimeter red lead to circuit wire 75 at stop switch. Refer to point to point schematic.
- c. Connect multimeter black lead to vehicle chassis ground.

NOTE

For stoplight circuit test, air pressure must be maintained at IS THERE CONTINUITY ACROSS CIRCUIT WIRE 75? operating pressure and brake pedal must be depressed.

- d. Start vehicle engine and depress brake pedal.
- e. Meter reading should be less than 200 ohms.

CONDITION/INDICATION

IS STOPLIGHT SWITCH OPERATING PROPERLY?

DECISION

NO - Replace defective stoplight switch (Volume 2, WP 0335). Go to Step (12) to verify problem is solved.
 YES - Go to Step (9).

STOPLIGHT INOPERATIVE (SERVICE OR BLACKOUT) - Continued**STEP**

9. IS THERE CONTINUITY ACROSS CIRCUIT WIRE 75?
 - a. Place battery switch to OFF position.
 - b. Disconnect circuit 75 wire at stoplight switch.
 - c. Remove lighting switch from instrument panel and disconnect harness connector (Volume 2, WP 0315).
 - d. Setup multimeter to measure ohms.

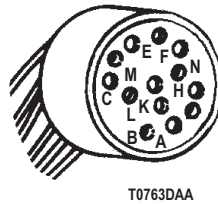

Figure 9. Main Lighting Switch Connector.

- e. Connect jumper cable between lighting system harness connector socket pins A and K. Refer to point to point schematic.
- f. Connect multimeter red lead to circuit wire 75 at stop switch.
- g. Connect multimeter black lead to other circuit wire 75 at stop switch.
- h. Meter reading should be less than 20 ohms.

CONDITION/INDICATION

IS THERE CONTINUITY ACROSS CIRCUIT WIRE 75?

DECISION

NO - Repair or replace broken circuit wire 75 (Volume 3, WP 0352). Go to Step (12) to verify problem is solved.
 YES - Go to Step (10).

STOPLIGHT INOPERATIVE (SERVICE OR BLACKOUT) - Continued**STEP****10. IS MAIN LIGHT SWITCH OPERATING PROPERLY?**

- a. Place battery switch to OFF position.

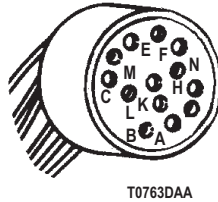

Figure 10. Main Lighting Switch Connector.

- b. Connect jumper cable from socket pin F to socket pin C. Refer to point to point schematics.

NOTE

- For stoplight circuit test, air pressure must be maintained at operating pressure and brake pedal must be depressed.
- If all service and blackout stoplights operate, main light switch is faulty.

- c. Start vehicle engine and depress brake pedal.
- d. Look for lighted service stoplights.
- e. Connect jumper cable from socket pin F to socket pin N.
- f. Look for lighted B.O stoplights.

CONDITION/INDICATION

IS MAIN LIGHT SWITCH OPERATING PROPERLY?

DECISION

NO - Replace defective main light switch (Volume 2, WP 0315). Go to Step (12) to verify problem is solved.
 YES - Go to Step (11).

STOPLIGHT INOPERATIVE (SERVICE OR BLACKOUT) - Continued

STEP

11. IS STOPLIGHT WIRING HARNESS IN GOOD CONDITION?

- a. Place battery switch to OFF position.

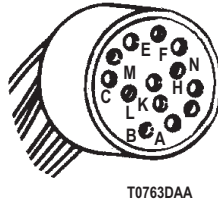

Figure 11. Main Lighting Switch Connector.

- b. Visually check wiring to rear composite light for damaged or loose wiring and connections. Refer to point to point schematic.

CONDITION/INDICATION

IS STOPLIGHT WIRING HARNESS IN GOOD CONDITION?

DECISION

- NO - Repair or replace broken wire (Volume 3, WP 0352). Go to Step (8) to verify problem is solved.
- YES - Notify supervisor. Action may not be possible at this level of maintenance.

STEP

12. IS YOUR ORIGINAL STOPLIGHT PROBLEM STILL PRESENT?

- a. Ensure vehicle is returned to normal operating condition.
- b. Check to see if your original stoplight problem still exists.

CONDITION/INDICATION

IS YOUR ORIGINAL STOPLIGHT PROBLEM STILL PRESENT?

DECISION

- YES - Notify supervisor.
- NO - Problem fixed.

END OF WORK PACKAGE

**FIELD MAINTENANCE
TAIL AND MARKER LIGHTS INOPERATIVE**

INITIAL SETUP:**Tools and Special Tools**

Tool Kit, General Mechanic's: Automotive
(Volume 5, WP 0826, Table 1, Item 56)
Multimeter
(Volume 5, WP 0826, Table 1, Item 34)
Test Set, Electronic Systems
(Volume 5, WP 0826, Table 1, Item 51)

References (cont.)

Volume 2, WP 0315
Volume 2, WP 0327
Volume 2, WP 0330
Volume 3, WP 0352

Personnel Required

(2)

Equipment Condition

Vehicle parked and engine shut down.
(TM 9-2320-272-10)

References

Point to Point Schematics

TROUBLESHOOTING PROCEDURE**TAIL AND MARKER LIGHTS INOPERATIVE****NOTE**

Conduct these malfunction tests if tail and marker lights are inoperative. This procedure will check for battery voltage at tail and marker light connector, lighting system harness connector and faulty wiring or connectors.

TAIL AND MARKER LIGHTS INOPERATIVE - Continued**STEP**

1. ARE BULBS IN GOOD CONDITION?



T1028DAA

Figure 1. Light Bulbs.

- a. If taillight is inoperative, replace taillight bulb with one known to be operative (Volume 2, WP 0327).
- b. If side marker light is inoperative, replace side marker light bulb with one known to be operative (Volume 2, WP 0330).

NOTE

If all tail and marker lights operates, bulb was faulty.

- c. Place battery switch to ON position.
- d. Place lighting switch to SERVICE DRIVE position.
- e. Check if all tail and marker lights operates.

CONDITION/INDICATION

ARE BULBS IN GOOD CONDITION?

DECISION

NO - Go to Step (8) to verify problem is solved.

YES - Go to Step (2).

STEP

2. ARE SOCKETS AND TERMINALS CLEAN AND IN GOOD CONDITION?

- a. Place battery switch to OFF position.

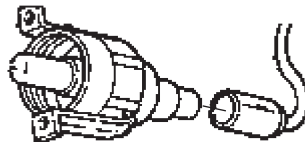

T1029DAA

Figure 2. Light Socket.

TAIL AND MARKER LIGHTS INOPERATIVE - Continued

- b. Visually check for corrosion or dirt in sockets or on terminals. Refer to point to point schematic.
- c. Clean corroded connections.

CONDITION/INDICATION

ARE SOCKETS AND TERMINALS CLEAN AND IN GOOD CONDITION?

DECISION

NO - Composite light defective. Replace defective composite light (Volume 2, WP 0327). Go to Step (8) to verify problem is solved.

NO - Marker light defective. Replace defective marker light (Volume 2, WP 0330). Go to Step (8) to verify problem is solved.

YES - Go to Step (3).

STEP

3. ARE LAMP HOLDERS IN GOOD OPERATING CONDITION?

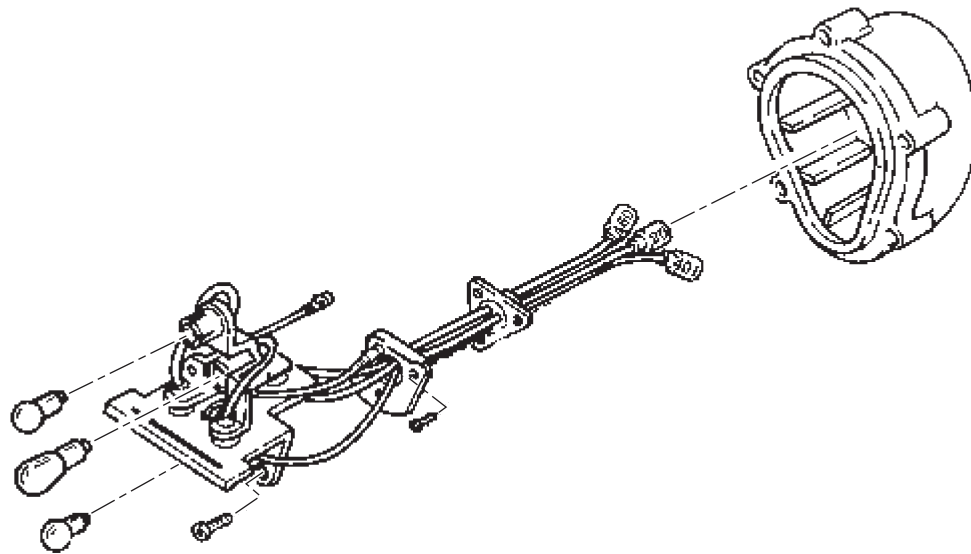

Figure 3. Lamp Holder.

Visually check lamp holders for loose and broken wire terminals. Refer to point to point schematic.

CONDITION/INDICATION

ARE LAMP HOLDERS IN GOOD OPERATING CONDITION?

DECISION

NO - Repair or replace broken wire (Volume 3, WP 0352). Go to Step (8) to verify problem is solved.

YES - Go to Step (4).

TAIL AND MARKER LIGHTS INOPERATIVE - Continued

STEP

4. IS THERE BATTERY VOLTAGE AT NON-OPERATING TAIL AND MARKER LAMP CONNECTOR?
 - a. Place battery switch to OFF position.

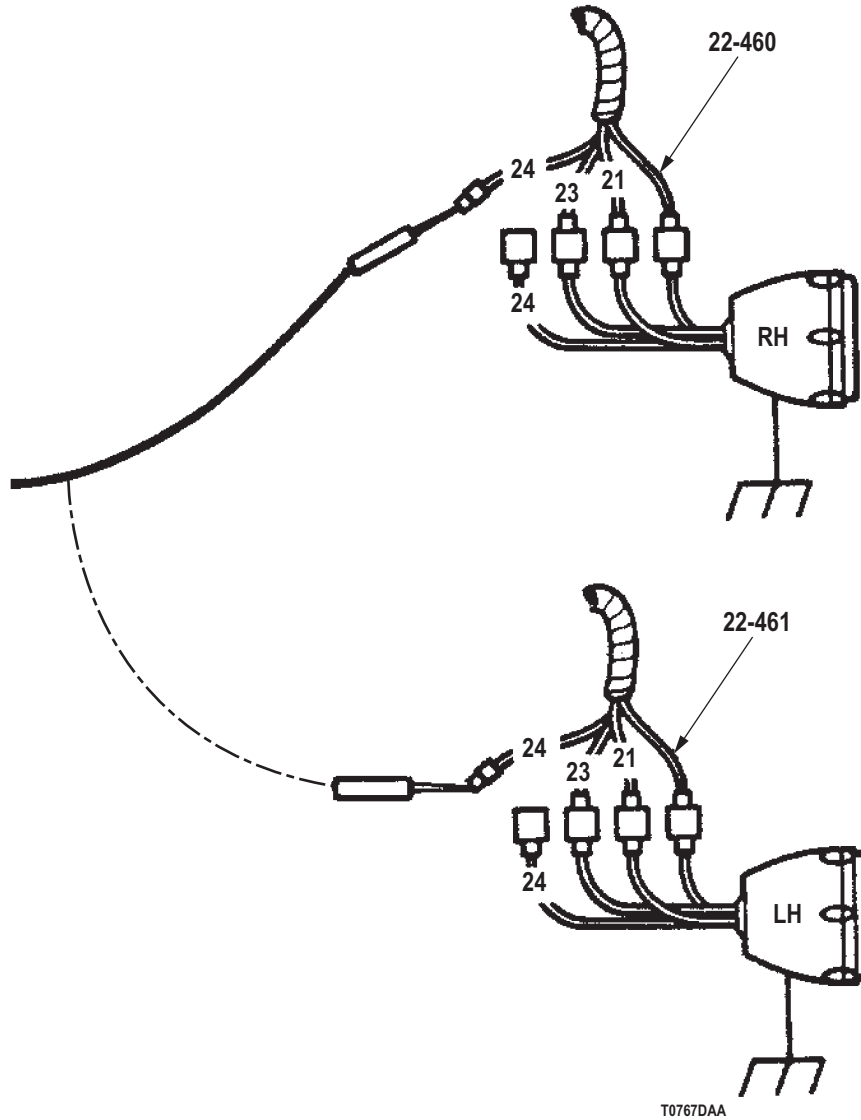

Figure 4. Rear Composite Light.

- b. Disconnect circuit 21 wire from inoperative rear composite lights (taillight).
- c. Disconnect circuit 489 wire from inoperative marker light.
- d. Place battery switch to ON position.
- e. Place lighting switch to SERVICE DRIVE position.
- f. Set up multimeter to measure VDC.

TAIL AND MARKER LIGHTS INOPERATIVE - Continued

- g. Connect multimeter red lead to disconnected wire. Refer to point to point schematics.
- h. Connect multimeter black lead to good ground.
- i. Meter reading should be greater than 18 VDC for each reading.

CONDITION/INDICATION

IS THERE BATTERY VOLTAGE AT NON-OPERATING TAIL AND MARKER LAMP CONNECTOR?

DECISION

YES - Voltage at wire 21. Replace defective composite light (Volume 2, WP 0327). Go to Step (8) to verify problem is solved.

YES - Voltage at wire 489. Replace defective marker light (Volume 2, WP 0330). Go to Step (8) to verify problem is solved.

NO - Go to Step (5).

STEP

- 5. IS THERE BATTERY VOLTAGE AT MAIN LIGHT SWITCH HARNESS CONNECTOR?
 - a. Place battery switch to OFF position.

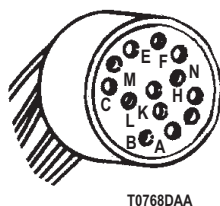

Figure 5. Main Lighting Switch Connector.

- b. Remove lighting switch from instrument panel and disconnect harness connector (Volume 2, WP 0315).
- c. Place battery switch to ON position.
- d. Connect multimeter red lead to connector socket pin F. Refer to point to point schematics.
- e. Connect multimeter black lead to good ground.
- f. Meter reading should be greater than 18 VDC.

CONDITION/INDICATION

IS THERE BATTERY VOLTAGE AT MAIN LIGHT SWITCH HARNESS CONNECTOR?

DECISION

NO - Go to Step (6).

YES - Go to Step (7).

TAIL AND MARKER LIGHTS INOPERATIVE - Continued

STEP

- 6. IS WIRING HARNESS IN GOOD CONDITION?
 - a. Place battery switch to OFF position.

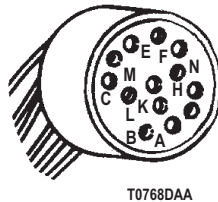

Figure 6. Main Lighting Switch Connector.

- b. Visually check wiring harness for loose connections or broken wiring. Refer to point to point schematic.

CONDITION/INDICATION

IS WIRING HARNESS IN GOOD CONDITION?

DECISION

NO - Repair or replace broken wire (Volume 3, WP 0352). Go to Step (8) to verify problem is solved.
 YES - Notify supervisor. Action may not be possible at this level of maintenance.

STEP

- 7. IS MAIN LIGHT SWITCH OPERATING PROPERLY?
 - a. Place battery switch to OFF position.

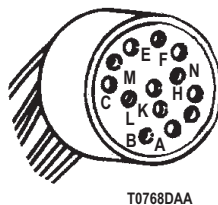

Figure 7. Main Lighting Switch Connector.

- b. Connect jumper cable from socket pin F to socket pin H. Refer to point to point schematics.
 - c. Place battery switch to ON position.

NOTE

If non-operating tail and marker lights illuminates, lighting switch is not operating properly.

- d. Look for lighted tail and marker lights.

TAIL AND MARKER LIGHTS INOPERATIVE - Continued**CONDITION/INDICATION**

IS MAIN LIGHT SWITCH OPERATING PROPERLY?

DECISION

NO - Replace defective main light switch (Volume 2, WP 0315). Go to Step (8) to verify problem is solved.

YES - Repair or replace wiring from main light switch to non-operating lamp (Volume 3, WP 0352). Go to Step (8) to verify problem is solved.

STEP

8. IS YOUR ORIGINAL TAIL OR MARKER LIGHT PROBLEM STILL PRESENT?
 - a. Ensure vehicle is returned to normal operating condition.
 - b. Check to see if your original tail or marker light problem still exists. Refer to point to point schematics.

CONDITION/INDICATION

IS YOUR ORIGINAL TAIL OR MARKER LIGHT PROBLEM STILL PRESENT?

DECISION

YES - Notify supervisor.

NO - Problem fixed.

END OF WORK PACKAGE

FIELD MAINTENANCE
INDIVIDUAL LIGHTS DO NOT LIGHT WITH DIRECTIONAL SIGNAL LEVER IN ANY POSITION

INITIAL SETUP:**Tools and Special Tools**

Tool Kit, General Mechanic's: Automotive
(Volume 5, WP 0826, Table 1, Item 56)
Multimeter
(Volume 5, WP 0826, Table 1, Item 34)
Test Set, Electronic Systems
(Volume 5, WP 0826, Table 1, Item 51)

References (cont.)

WP 0098
Volume 2, WP 0327
Volume 3, WP 0352

Equipment Condition

Vehicle parked and engine shut down.
(TM 9-2320-272-10)

Personnel Required

(2)

References

Point to Point Schematics

TROUBLESHOOTING PROCEDURE**INDIVIDUAL LIGHTS DO NOT LIGHT WITH DIRECTIONAL SIGNAL LEVER IN ANY POSITION****NOTE**

Conduct these malfunction tests if signal lamps do not light with directional signal control lever in any ON position. This procedure will check for defective lamps, dirty lamp sockets, and frayed or pinched wires.

INDIVIDUAL LIGHTS DO NOT LIGHT WITH DIRECTIONAL SIGNAL LEVER IN ANY POSITION - Continued**STEP**

1. IS LAMP IN GOOD OPERATING CONDITION?



T1031DAA

Figure 1. Light Bulbs.

- a. Replace non-operating signal bulb with one known to be operative (Volume 2, WP 0327).
- b. Place battery switch to ON position.
- c. Place main lighting switch in STOP TURN position.
- d. Place directional signal control lever to HAZARD warning position.

NOTE

If all turn signal lights flash, bulb is faulty.

- e. Check if stop signal lamps flash.

CONDITION/INDICATION

IS LAMP IN GOOD OPERATING CONDITION?

DECISION

NO - Signal lamp bulb was faulty. Go to Step (5) to verify problem is solved.
 YES - Go to Step (2).

STEP

2. DOES BATTERY VOLTAGE CYCLE ON AND OFF AT CONNECTOR OF LAMP THAT DOES NOT ILLUMINATE?
- a. Place battery switch to OFF position.
 - b. If right front turn signal not illuminating, disconnect wire 461 at right front composite light.
 - c. If left front turn signal not illuminating, disconnect wire 460 at left front composite light.
 - d. If right rear turn signal not illuminating, disconnect wire 22-461 at right rear composite light.
 - e. If left rear turn signal not illuminating, disconnect wire 21-460 at left rear composite light.
 - f. Place battery switch to ON position.
 - g. Place main lighting switch in STOP TURN position.
 - h. Place directional signal control lever to HAZARD warning position.
 - i. Set up multimeter to measure VDC.

INDIVIDUAL LIGHTS DO NOT LIGHT WITH DIRECTIONAL SIGNAL LEVER IN ANY POSITION - Continued

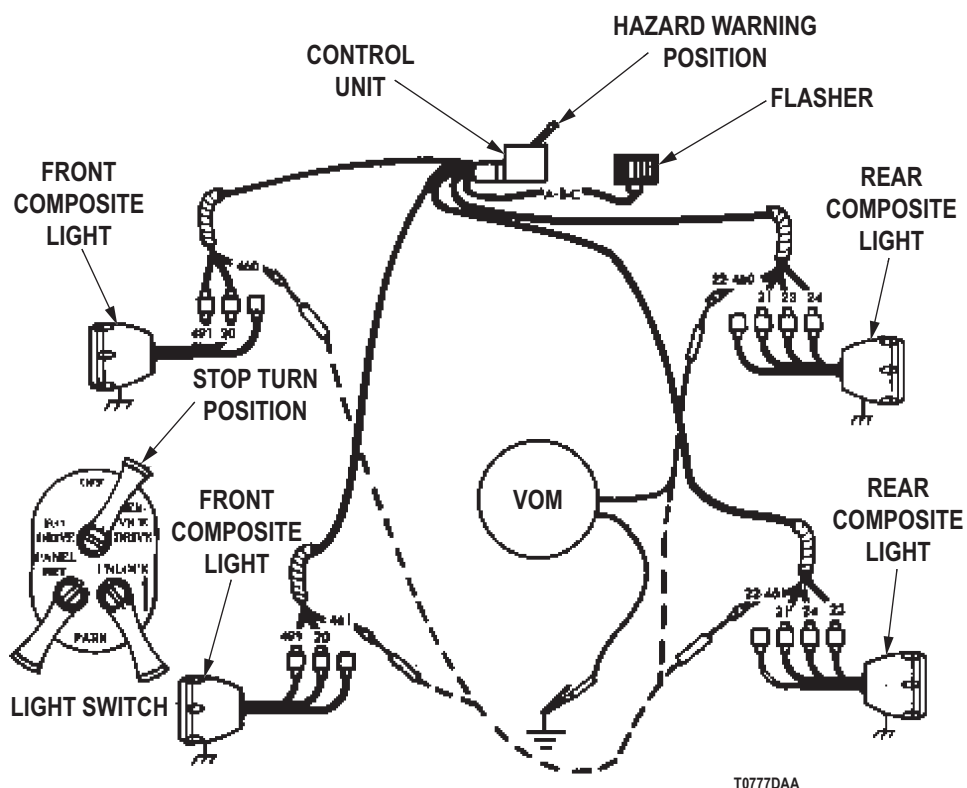

Figure 2. Directional Signal Circuit Test.

- j. Connect multimeter red lead to disconnected wire. Refer to point to point schematics.
- k. Connect multimeter black lead to a known good ground.
- l. Meter reading should cycle from 0 to greater than 18 VDC at a rate of 1 to 2 cycles per second.

CONDITION/INDICATION

DOES BATTERY VOLTAGE CYCLE ON AND OFF AT CONNECTOR OF LAMP THAT DOES NOT ILLUMINATE?

DECISION

- NO - Go to Step (3).
 YES - Clean light socket and install lamp. Go to Step (5) to verify problem is solved.

INDIVIDUAL LIGHTS DO NOT LIGHT WITH DIRECTIONAL SIGNAL LEVER IN ANY POSITION - Continued

STEP

3. IS THERE CONTINUITY THROUGH WIRE THAT CONNECTS TO FAULTY LAMP?

- a. Place battery switch to OFF position.
- b. Jumper disconnected wire to a known good ground.

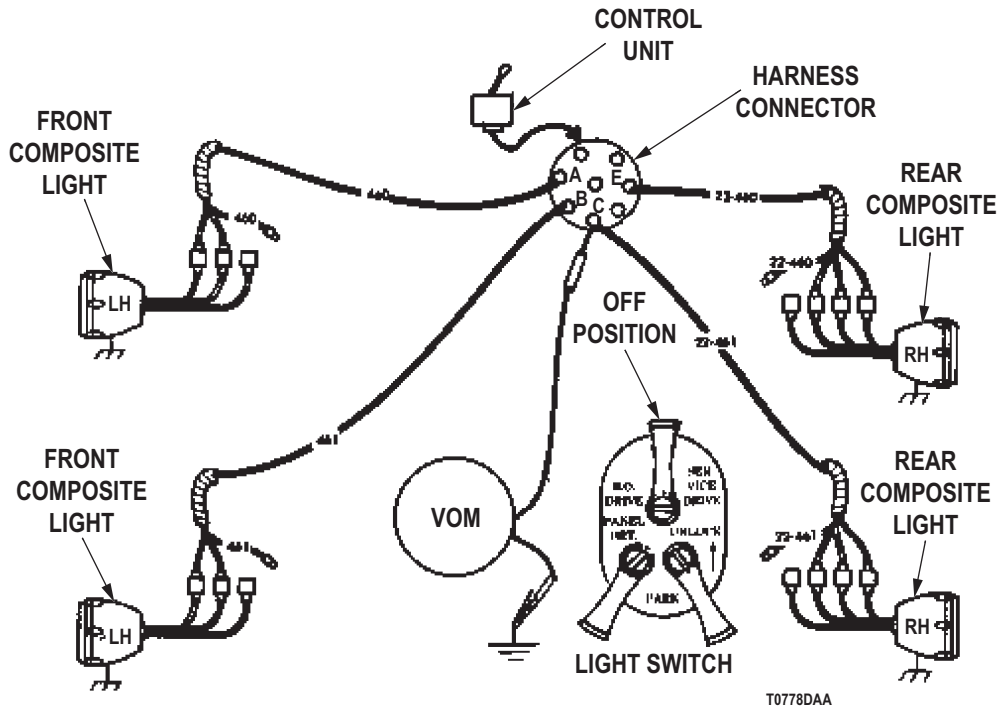

Figure 3. Directional Signal Circuit Test.

- c. Disconnect wire connector from control unit.
- d. Set up multimeter to measure resistance.
- e. Near control unit, connect multimeter black lead to good ground.
- f. If wire 461 is disconnected, connect multimeter red lead to circuit 461 wire at socket point B. Refer to point to point schematics.
- g. If wire 460 is disconnected, connect multimeter red lead to circuit 460 wire at socket point A.
- h. If wire 22-461 is disconnected, connect multimeter red lead to circuit 22-461 wire at socket point C.
- i. If wire 21-460 is disconnected, connect multimeter red lead to circuit 21-460 wire at socket point E.
- j. Meter reading should be less than 20 ohms.

CONDITION/INDICATION

IS THERE CONTINUITY THROUGH WIRE THAT CONNECTS TO FAULTY LAMP?

DECISION

- NO - Repair broken wire (Volume 3, WP 0352). Go to Step (5) to verify problem is solved.
- YES - Go to Step (4).

INDIVIDUAL LIGHTS DO NOT LIGHT WITH DIRECTIONAL SIGNAL LEVER IN ANY POSITION - Continued**STEP**

4. IS THERE A SHORT IN THE WIRING HARNESS?
 - a. Remove jumper from disconnected wire and ground.

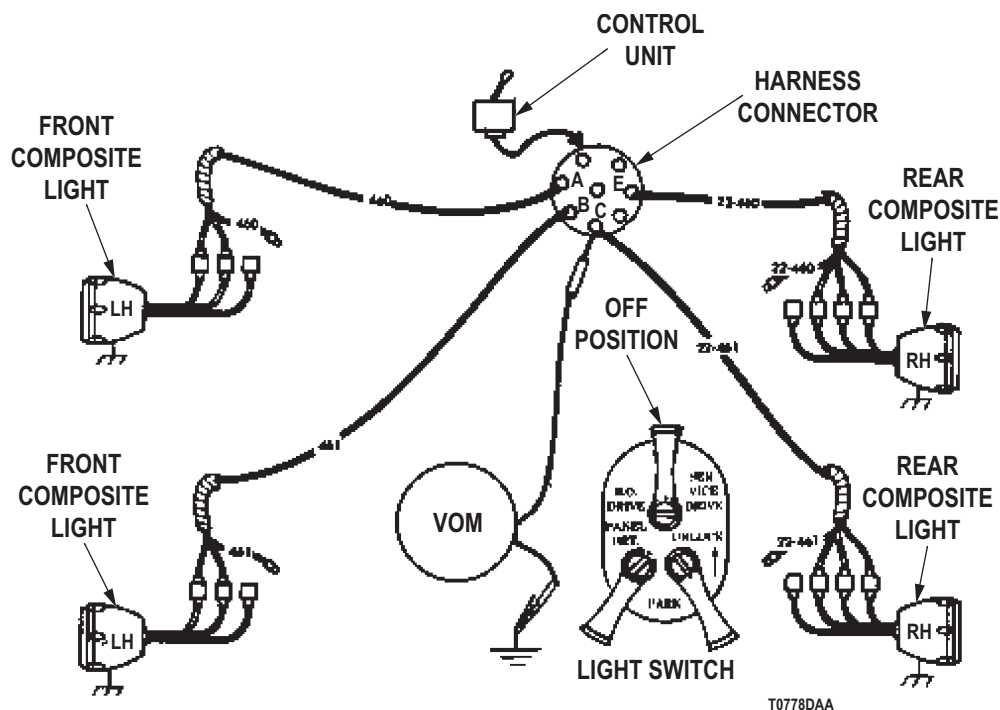

Figure 4. Directional Signal Circuit Test.

- b. Near control unit, connect multimeter black lead to good ground.
- c. If wire 461 is disconnected, connect multimeter red lead to circuit 461 wire at socket point B. Refer to point to point schematics.
- d. If wire 460 is disconnected, connect multimeter red lead to circuit 460 wire at socket point A.
- e. If wire 22-461 is disconnected, connect multimeter red lead to circuit 22-461 wire at socket point C.
- f. If wire 21-460 is disconnected, connect multimeter red lead to circuit 21-460 wire at socket point E.
- g. Meter reading should be greater than 10,000 ohms.

CONDITION/INDICATION

IS THERE A SHORT IN THE WIRING HARNESS?

DECISION

YES - Repair frayed, or pinched wire (Volume 3, WP 0352). Go to Step (5) to verify problem is solved.
 NO - Perform No Lights Operate With Directional Signal Lever In Any Position (WP 0098) troubleshooting.

INDIVIDUAL LIGHTS DO NOT LIGHT WITH DIRECTIONAL SIGNAL LEVER IN ANY POSITION - Continued**STEP**

5. IS YOUR ORIGINAL PROBLEM STILL PRESENT?
 - a. Ensure vehicle is returned to normal operating condition.
 - b. Check to see if your original problem still exists.

CONDITION/INDICATION

IS YOUR ORIGINAL PROBLEM STILL PRESENT?

DECISION

YES - Notify supervisor.
NO - Problem fixed.

END OF WORK PACKAGE

FIELD MAINTENANCE
NO LIGHTS OPERATE WITH DIRECTIONAL SIGNAL CONTROL LEVER IN ANY POSITION

INITIAL SETUP:**Tools and Special Tools**

Tool Kit, General Mechanic's: Automotive
(Volume 5, WP 0826, Table 1, Item 56)
Multimeter
(Volume 5, WP 0826, Table 1, Item 34)
Test Set, Electronic Systems
(Volume 5, WP 0826, Table 1, Item 51)

References (cont.)

WP 0099
Volume 2, WP 0315
Volume 2, WP 0318
Volume 3, WP 0352

Personnel Required

(2)

Equipment Condition

Vehicle parked and engine shut down.
(TM 9-2320-272-10)

References

Point to Point Schematics

TROUBLESHOOTING PROCEDURE**NO LIGHTS OPERATE WITH DIRECTIONAL SIGNAL CONTROL LEVER IN ANY POSITION****NOTE**

Conduct these malfunction tests if no lights operate with directional signal control lever in any ON position. This procedure will check the control unit cable and flasher.

NO LIGHTS OPERATE WITH DIRECTIONAL SIGNAL CONTROL LEVER IN ANY POSITION - Continued

STEP

1. IS THERE BATTERY VOLTAGE AT PIN G OF THE CONNECTOR CONTROL UNIT?
 - a. Place battery switch to OFF position.

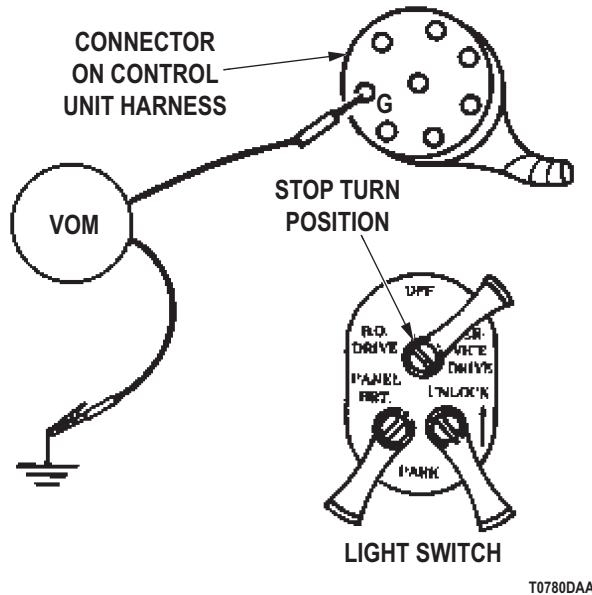

Figure 1. Control Unit Harness Connector.

- b. Disconnect control unit harness connector from directional signal control unit.
- c. Place battery switch to ON position.
- d. Place lighting switch to STOP TURN position.
- e. Set up multimeter to measure VDC.
- f. Connect multimeter red lead to connector terminal point G. Refer to point to point schematics.
- g. Connect multimeter black lead to a known good ground.
- h. Meter reading should be greater than 18 VDC.

CONDITION/INDICATION

IS THERE BATTERY VOLTAGE AT PIN G OF THE CONNECTOR CONTROL UNIT?

DECISION

- NO - Go to Step (2).
- YES - Go to Step (5).

STEP

2. IS THERE BATTERY VOLTAGE AT MAIN LIGHT SWITCH HARNESS CONNECTOR?
 - a. Place battery switch to OFF position.

NO LIGHTS OPERATE WITH DIRECTIONAL SIGNAL CONTROL LEVER IN ANY POSITION - Continued

Figure 2. Main Lighting Switch Connector.

- b. Remove lighting switch from instrument panel and disconnect harness connector (Volume 2, WP 0315).
- c. Place battery switch to ON position.
- d. Connect multimeter red lead to connector socket pin F. Refer to point to point schematics.
- e. Connect multimeter black lead to good ground.
- f. Meter reading should be greater than 18 VDC.

CONDITION/INDICATION

IS THERE BATTERY VOLTAGE AT MAIN LIGHT SWITCH HARNESS CONNECTOR?

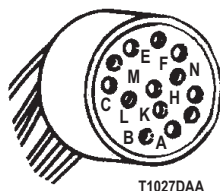
DECISION

NO - Go to Step (3).
 YES - Go to Step (4).

STEP

3. IS WIRING HARNESS IN GOOD CONDITION?
 - a. Place battery switch to OFF position.

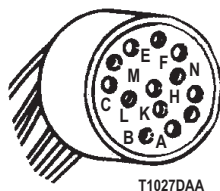

Figure 3. Main Lighting Switch Connector.

- b. Visually check wiring harness for loose connections or broken wiring. Refer to point to point schematic.

CONDITION/INDICATION

IS WIRING HARNESS IN GOOD CONDITION?

DECISION

NO - Repair or replace broken wire (Volume 3, WP 0352). Go to Step (9) to verify problem is solved.
 YES - Notify supervisor. Action may not be possible at this level of maintenance.

NO LIGHTS OPERATE WITH DIRECTIONAL SIGNAL CONTROL LEVER IN ANY POSITION - Continued**STEP**

4. IS MAIN LIGHT SWITCH OPERATING PROPERLY?
- a. Place battery switch to OFF position.

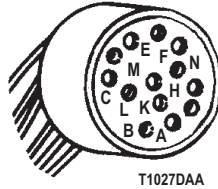

Figure 4. Main Lighting Switch Connector.

- b. Connect jumper cable from socket pin F to socket pin J. Refer to point to point schematics.
- c. Place battery switch to ON position.
- d. Connect multimeter red lead to control unit harness connector socket pin G.
- e. Connect multimeter black lead to good ground.

NOTE

If meter reading is greater than 18 VDC, main light switch is faulty.

- f. Meter reading should be greater than 18 VDC.

CONDITION/INDICATION

IS MAIN LIGHT SWITCH OPERATING PROPERLY?

DECISION

NO - Replace defective main light switch (Volume 2, WP 0315). Go to Step (9) to verify problem is solved.
 YES - Repair or replace wiring from main light switch to control unit (Volume 3, WP 0352). Go to Step (9) to verify problem is solved.

NO LIGHTS OPERATE WITH DIRECTIONAL SIGNAL CONTROL LEVER IN ANY POSITION - Continued

STEP

5. IS THERE CONTINUITY BETWEEN TERMINAL A OF THE FLASHER UNIT AND TERMINAL H OF THE CONTROL UNIT CABLE?
 - a. Set up multimeter to measure resistance.

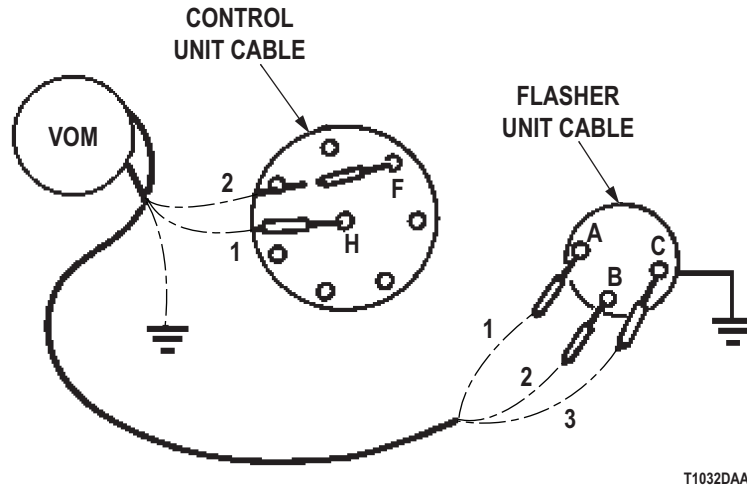

T1032DAA

Figure 5. Flasher Wire Harness Test.

- b. Connect multimeter red lead to terminal H of the control unit cable. Refer to point to point schematics.
- c. Connect multimeter black lead to terminal A of the flasher units.
- d. Meter reading should be less than 20 ohms.

CONDITION/INDICATION

IS THERE CONTINUITY BETWEEN TERMINAL A OF THE FLASHER UNIT AND TERMINAL H OF THE CONTROL UNIT CABLE?

DECISION

NO - Repair faulty wire (Volume 3, WP 0352). Go to Step (9) to verify problem is solved.
 YES - Go to Step (6).

NO LIGHTS OPERATE WITH DIRECTIONAL SIGNAL CONTROL LEVER IN ANY POSITION - Continued

STEP

6. IS THERE CONTINUITY BETWEEN TERMINAL B OF THE FLASHER UNIT AND TERMINAL F OF THE CONTROL UNIT CABLE?

- a. Connect multimeter red lead to terminal F of the control unit cable. Refer to point to point schematics.

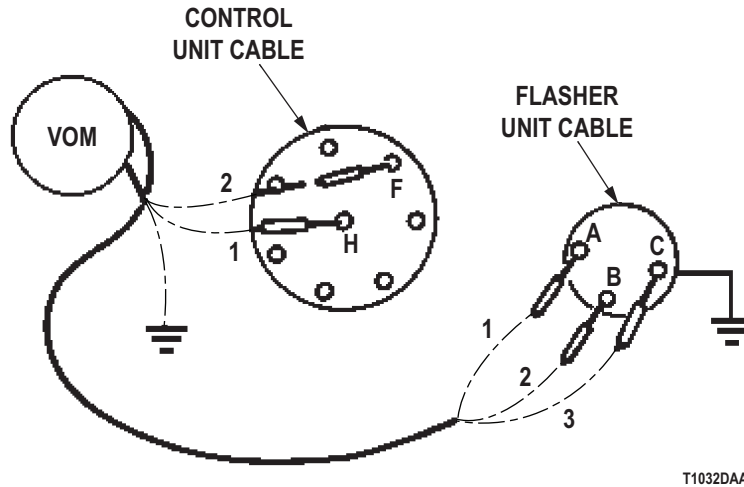

Figure 6. Flasher Wire Harness Test.

- b. Connect multimeter black lead to terminal B of the flasher units.
- c. Meter reading should be less than 20 ohms.

CONDITION/INDICATION

IS THERE CONTINUITY BETWEEN TERMINAL B OF THE FLASHER UNIT AND TERMINAL F OF THE CONTROL UNIT CABLE?

DECISION

- NO - Repair faulty wire (Volume 3, WP 0352). Go to Step (9) to verify problem is solved.
- YES - Go to Step (7).

NO LIGHTS OPERATE WITH DIRECTIONAL SIGNAL CONTROL LEVER IN ANY POSITION - Continued

STEP

7. IS THERE CONTINUITY BETWEEN TERMINAL C OF THE FLASHER UNIT AND GROUND?

- a. Connect multimeter red lead to terminal C of the flasher unit. Refer to point to point schematics.

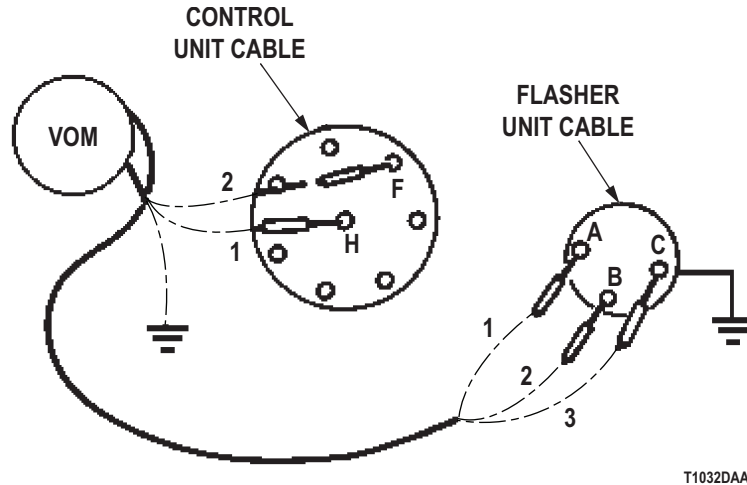

T1032DAA

Figure 7. Flasher Wire Harness Test.

- b. Connect multimeter black lead to a known good ground.
- c. Meter reading should be less than 20 ohms.

CONDITION/INDICATION

IS THERE CONTINUITY BETWEEN TERMINAL C OF THE FLASHER UNIT AND GROUND?

DECISION

- NO - Repair faulty wire (Volume 3, WP 0352). Go to Step (9) to verify problem is solved.
- YES - Go to Step (8).

STEP

8. IS YOUR ORIGINAL PROBLEM STILL PRESENT AFTER REPLACING FLASHER UNIT?

- a. Replace flasher unit (Volume 2, WP 0318).
- b. Ensure vehicle is returned to normal operating condition.
- c. Check to see if your original problem still exists.

CONDITION/INDICATION

IS YOUR ORIGINAL PROBLEM STILL PRESENT AFTER REPLACING FLASHER UNIT?

DECISION

- YES - Perform System Operates Incorrectly In One Or More Positions Of Directional Signal Control Lever troubleshooting (WP 0099).
- NO - Problem fixed.

NO LIGHTS OPERATE WITH DIRECTIONAL SIGNAL CONTROL LEVER IN ANY POSITION - Continued**STEP**

9. IS YOUR ORIGINAL PROBLEM STILL PRESENT?
 - a. Ensure vehicle is returned to normal operating condition.
 - b. Check to see if your original problem still exists.

CONDITION/INDICATION

IS YOUR ORIGINAL PROBLEM STILL PRESENT?

DECISION

YES - Notify supervisor.
NO - Problem fixed.

END OF WORK PACKAGE

FIELD MAINTENANCE
SYSTEM OPERATES INCORRECTLY IN ONE OR MORE POSITIONS OF DIRECTIONAL SIGNAL CONTROL LEVER

INITIAL SETUP:**Tools and Special Tools**

Tool Kit, General Mechanic's: Automotive
(Volume 5, WP 0826, Table 1, Item 56)
Multimeter
(Volume 5, WP 0826, Table 1, Item 34)
Test Set, Electronic Systems
(Volume 5, WP 0826, Table 1, Item 51)

References

Point to Point Schematics
Volume 2, WP 0317

Equipment Condition

Vehicle parked and engine shut down.
(TM 9-2320-272-10)

Personnel Required

(2)

TROUBLESHOOTING PROCEDURE**SYSTEM OPERATES INCORRECTLY IN ONE OR MORE POSITIONS OF DIRECTIONAL SIGNAL CONTROL LEVER****NOTE**

Conduct these malfunction tests if the system operates incorrectly in one or more positions of directional signal control lever. This procedure will check for a defective directional signal control unit.

SYSTEM OPERATES INCORRECTLY IN ONE OR MORE POSITIONS OF DIRECTIONAL SIGNAL CONTROL LEVER - Continued

STEP

1. DO THE ELECTRICAL CONTACTS INSIDE THE DIRECTIONAL SIGNAL CONTROL UNIT WORK PROPERLY WHEN IN "NEUTRAL" POSITION?
 - a. Set up multimeter to measure resistance.
 - b. Disconnect control unit harness connector from directional signal control unit.
 - c. Remove indicator lamp from directional signal control.
 - d. Set control lever to "Neutral" position.

DIRECTIONAL SIGNAL CONTROL LEVER IN "NEUTRAL" POSITION

TEST PROBE LEADS		CONTINUITY INDICATION
BLACK (-)	RED (+)	
H	A	OPEN
H	B	OPEN
H	C	OPEN
H	E	OPEN
D	C	SHORTED
D	E	SHORTED
F	G	OPEN

T0782DAA

Figure 1. Directional Signal Control Neutral Position.

- e. Connect multimeter black lead to first location listed in graphic. Refer to point to point schematics.
- f. Connect multimeter red lead to first location listed in graphic.
- g. Note reading and compare to the first location listed under "Continuity Indication". Meter reading should be greater than 10,000 ohms for open indication.
- h. Move black and red multimeter leads to each location listed in the graphic and compare the readings to those listed under "Continuity Indication".

CONDITION/INDICATION

DO THE ELECTRICAL CONTACTS INSIDE THE DIRECTIONAL SIGNAL CONTROL UNIT WORK PROPERLY WHEN IN "NEUTRAL" POSITION?

DECISION

- NO - Replace directional signal control unit (Volume 2, WP 0317). Go to Step (5) to verify problem is solved.
 YES - Go to Step (2).

SYSTEM OPERATES INCORRECTLY IN ONE OR MORE POSITIONS OF DIRECTIONAL SIGNAL CONTROL LEVER - Continued

STEP

2. DO THE ELECTRICAL CONTACTS INSIDE THE DIRECTIONAL SIGNAL CONTROL UNIT WORK PROPERLY WHEN IN "RIGHT TURN" POSITION?
 - a. Set control lever to "Right Turn" position.

DIRECTIONAL SIGNAL CONTROL LEVER IN "RIGHT TURN" POSITION

TEST PROBE LEADS		CONTINUITY INDICATION
BLACK (-)	RED (+)	
F	G	SHORTED
H	A	SHORTED
H	E	SHORTED
H	B	OPEN
H	C	OPEN
D	C	SHORTED
D	E	OPEN

T0783DAA

Figure 2. Directional Signal Control Right Turn Position.

- b. Connect multimeter black lead to first location listed in graphic. Refer to point to point schematics.
- c. Connect multimeter red lead to first location listed in graphic.
- d. Note reading and compare to the first location listed under "Continuity Indication". Meter reading should be greater than 10,000 ohms for open indication.
- e. Move black and red multimeter leads to each location listed in the graphic and compare the readings to those listed under "Continuity Indication".

CONDITION/INDICATION

DO THE ELECTRICAL CONTACTS INSIDE THE DIRECTIONAL SIGNAL CONTROL UNIT WORK PROPERLY WHEN IN "RIGHT TURN" POSITION?

DECISION

NO - Replace directional signal control unit (Volume 2, WP 0317). Go to Step (5) to verify problem is solved.
 YES - Go to Step (3).

SYSTEM OPERATES INCORRECTLY IN ONE OR MORE POSITIONS OF DIRECTIONAL SIGNAL CONTROL LEVER - Continued

STEP

3. DO THE ELECTRICAL CONTACTS INSIDE THE DIRECTIONAL SIGNAL CONTROL UNIT WORK PROPERLY WHEN IN "LEFT TURN" POSITION?
 - a. Set control lever to "Left Turn" position.

DIRECTIONAL SIGNAL CONTROL LEVER IN "LEFT TURN" POSITION

TEST PROBE LEADS		CONTINUITY INDICATION
BLACK (-)	RED (+)	
H	B	SHORTED
H	C	SHORTED
H	A	OPEN
H	E	OPEN
F	G	SHORTED
D	E	SHORTED
D	C	OPEN

T0784DAA

Figure 3. Directional Signal Control Left Turn Position.

- b. Connect multimeter black lead to first location listed in graphic. Refer to point to point schematics.
- c. Connect multimeter red lead to first location listed in graphic.
- d. Note reading and compare to the first location listed under "Continuity Indication". Meter reading should be greater than 10,000 ohms for open indication.
- e. Move black and red multimeter leads to each location listed in the graphic and compare the readings to those listed under "Continuity Indication".

CONDITION/INDICATION

DO THE ELECTRICAL CONTACTS INSIDE THE DIRECTIONAL SIGNAL CONTROL UNIT WORK PROPERLY WHEN IN "LEFT TURN" POSITION?

DECISION

NO - Replace directional signal control unit (Volume 2, WP 0317). Go to Step (5) to verify problem is solved.
 YES - Go to Step (4).

STEP

4. DO THE ELECTRICAL CONTACTS INSIDE THE DIRECTIONAL SIGNAL CONTROL UNIT WORK PROPERLY WHEN IN "HAZARD WARNING" POSITION?
 - a. Set control lever to "Hazard Warning" position.

SYSTEM OPERATES INCORRECTLY IN ONE OR MORE POSITIONS OF DIRECTIONAL SIGNAL CONTROL LEVER - Continued

DIRECTIONAL SIGNAL CONTROL LEVER IN "HAZARD WARNING" POSITION		
TEST PROBE LEADS		CONTINUITY INDICATION
BLACK (-)	RED (+)	
H	G	SHORTED
H	A	SHORTED
H	E	SHORTED
H	B	SHORTED
D	C	OPEN
D	C	OPEN
F	E	SHORTED

T0785DAA

Figure 4. Directional Signal Control Hazard Position.

- b. Connect multimeter black lead to first location listed in graphic. Refer to point to point schematics.
- c. Connect multimeter red lead to first location listed in graphic.
- d. Note reading and compare to the first location listed under "Continuity Indication". Meter reading should be greater than 10,000 ohms for open indication.
- e. Move black and red multimeter leads to each location listed in the graphic and compare the readings to those listed under "Continuity Indication".

CONDITION/INDICATION

DO THE ELECTRICAL CONTACTS INSIDE THE DIRECTIONAL SIGNAL CONTROL UNIT WORK PROPERLY WHEN IN "HAZARD WARNING" POSITION?

DECISION

NO - Replace directional signal control unit (Volume 2, WP 0317). Go to Step (5) to verify problem is solved.
YES - Go to Step (5) to verify problem is solved.

STEP

5. IS YOUR ORIGINAL PROBLEM STILL PRESENT?
 - a. Ensure vehicle is returned to normal operating condition.
 - b. Check to see if your original problem still exists.

CONDITION/INDICATION

IS YOUR ORIGINAL PROBLEM STILL PRESENT?

DECISION

YES - Notify supervisor.
NO - Problem fixed.

END OF WORK PACKAGE

**FIELD MAINTENANCE
PROTECTIVE CONTROL BOX ASSEMBLY TEST**

INITIAL SETUP:**Tools and Special Tools**

Tool Kit, General Mechanic's: Automotive
(Volume 5, WP 0826, Table 1, Item 56)
Multimeter
(Volume 5, WP 0826, Table 1, Item 34)
Test Set, Electronic Systems
(Volume 5, WP 0826, Table 1, Item 51)

References

Point to Point Schematics
Volume 2, WP 0319

Equipment Condition

Vehicle parked and engine shut down.
(TM 9-2320-272-10)

Personnel Required

(2)

TROUBLESHOOTING PROCEDURE**PROTECTIVE CONTROL BOX ASSEMBLY TEST****NOTE**

Conduct these malfunction tests if protective control box is not operating properly. This procedure will check for fault protection control box.

PROTECTIVE CONTROL BOX ASSEMBLY TEST - Continued

STEP

1. IS PROTECTIVE CONTROL BOX PROPERLY GROUNDED?
 - a. Disconnect connector from protective control box.
 - b. Set up multimeter to measure ohms.

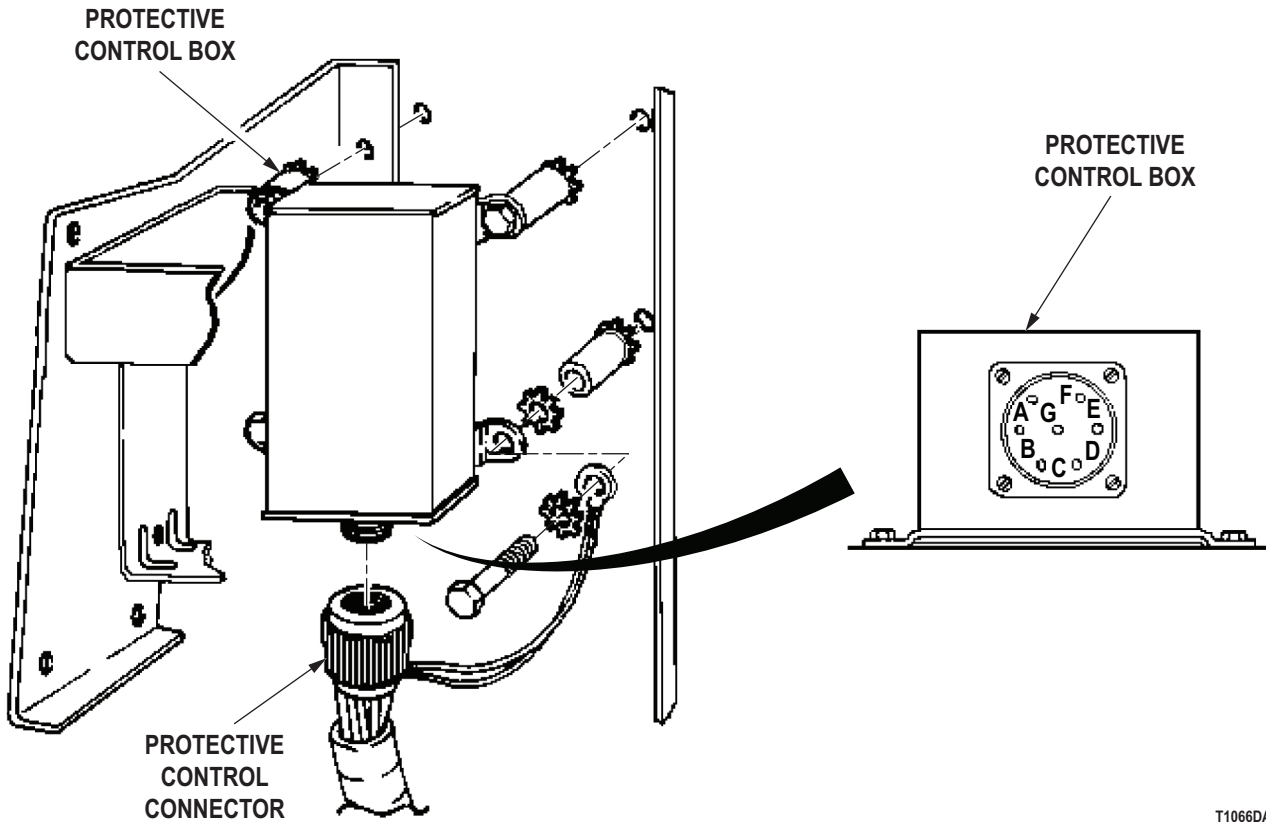

T1066DAA

Figure 1. Protective Control Box Connector.

- c. Connect multimeter red lead to protective control box connector pin E. Refer to point to point schematics.
- d. Connect multimeter black lead to chassis ground.
- e. Meter reading should be less than 200 ohms.

CONDITION/INDICATION

IS PROTECTIVE CONTROL BOX PROPERLY GROUNDED?

DECISION

- NO - Replace protective control box (Volume 2, WP 0319). Go to Step (10) to verify problem is solved.
 YES - Go to Step (2).

PROTECTIVE CONTROL BOX ASSEMBLY TEST - Continued**STEP**

2. IS THERE NO CONTINUITY BETWEEN PROTECTIVE CONTROL BOX CONNECTOR PINS B AND D?

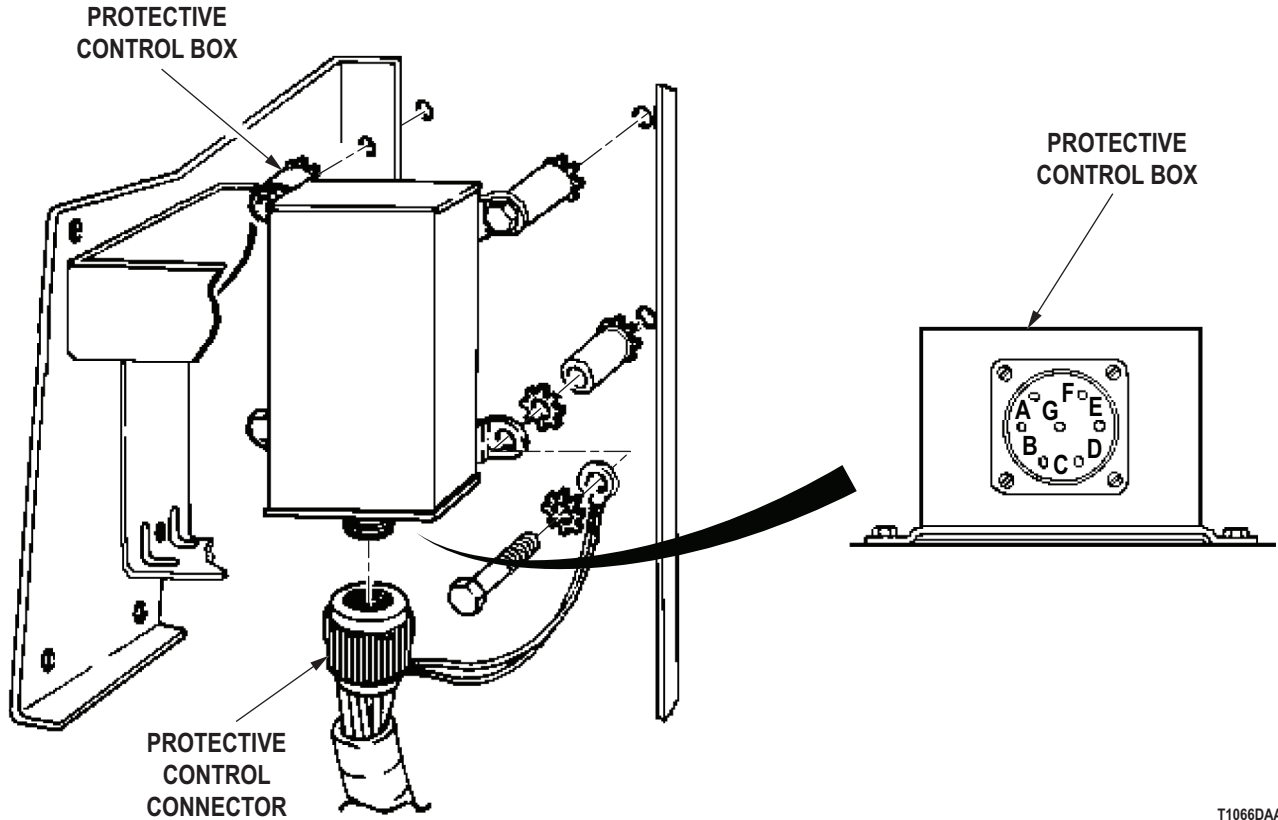

T1066DAA

Figure 2. Protective Control Box Connector.

- a. Connect multimeter red lead to protective control box connector pin B. Refer to point to point schematics.
- b. Connect multimeter black lead to protective control box connector pin D.
- c. Meter reading should be less than 200 ohms.

CONDITION/INDICATION

IS THERE NO CONTINUITY BETWEEN PROTECTIVE CONTROL BOX CONNECTOR PINS B AND D?

DECISION

NO - Replace protective control box (Volume 2, WP 0319). Go to Step (10) to verify problem is solved.
 YES - Go to Step (3).

PROTECTIVE CONTROL BOX ASSEMBLY TEST - Continued**STEP**

3. IS THERE NO CONTINUITY BETWEEN PROTECTIVE CONTROL BOX CONNECTOR PINS C AND D?

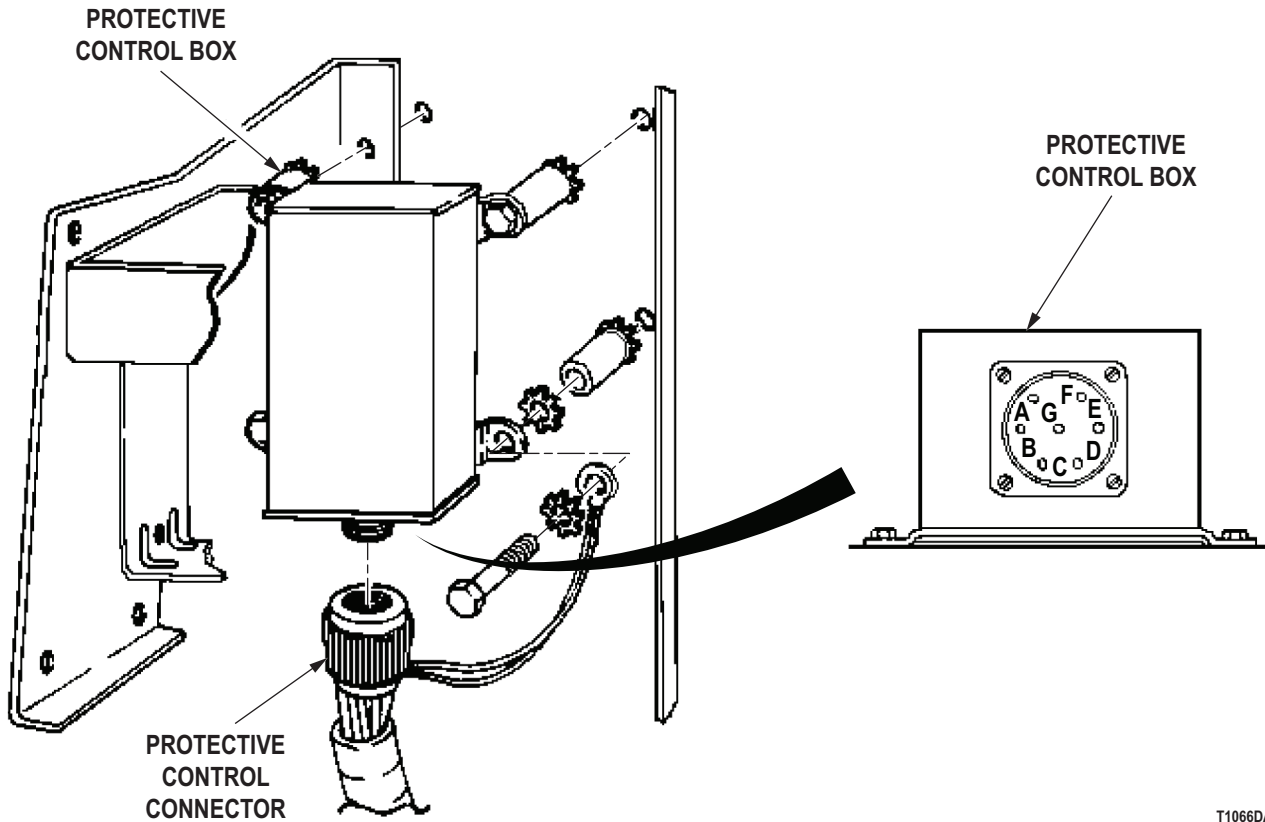

T1066DAA

Figure 3. Protective Control Box Connector.

- Connect multimeter red lead to protective control box connector pin C. Refer to point to point schematics.
- Connect multimeter black lead to protective control box connector pin D.
- Meter reading should be less than 200 ohms.

CONDITION/INDICATION

IS THERE NO CONTINUITY BETWEEN PROTECTIVE CONTROL BOX CONNECTOR PINS C AND D?

DECISION

NO - Replace protective control box (Volume 2, WP 0319). Go to Step (10) to verify problem is solved.
 YES - Go to Step (4).

PROTECTIVE CONTROL BOX ASSEMBLY TEST - Continued**STEP**

4. IS THERE NO CONTINUITY BETWEEN PROTECTIVE CONTROL BOX CONNECTOR PINS A AND GROUND?

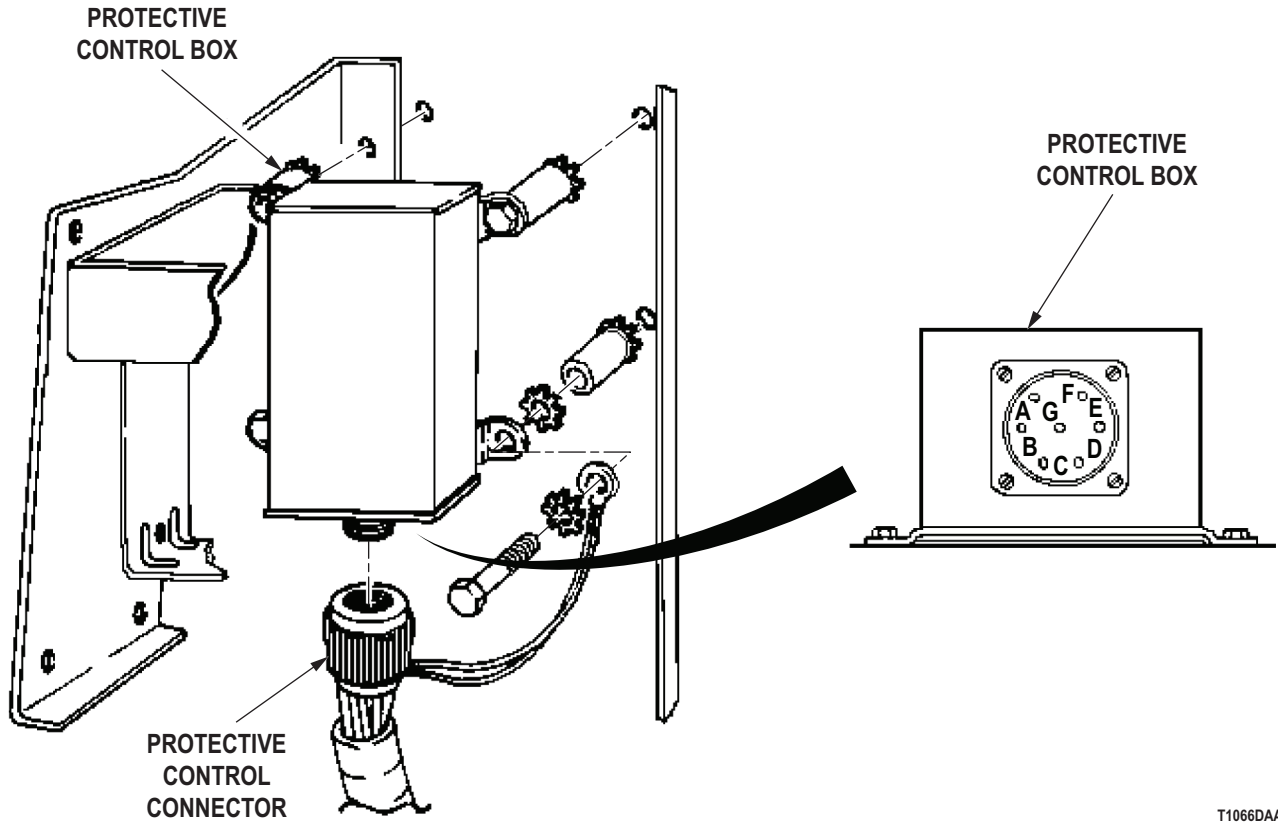

T1066DAA

Figure 4. Protective Control Box Connector.

- a. Connect multimeter red lead to protective control box connector pin A. Refer to point to point schematics.
- b. Connect multimeter black lead to chassis ground.
- c. Meter reading should be about 1,000 ohms.

CONDITION/INDICATION

IS THERE NO CONTINUITY BETWEEN PROTECTIVE CONTROL BOX CONNECTOR PINS A AND GROUND?

DECISION

NO - Replace protective control box (Volume 2, WP 0319). Go to Step (10) to verify problem is solved.
 YES - Go to Step (5).

PROTECTIVE CONTROL BOX ASSEMBLY TEST - Continued**STEP**

5. IS THERE NO CONTINUITY BETWEEN PROTECTIVE CONTROL BOX CONNECTOR PINS B AND GROUND?

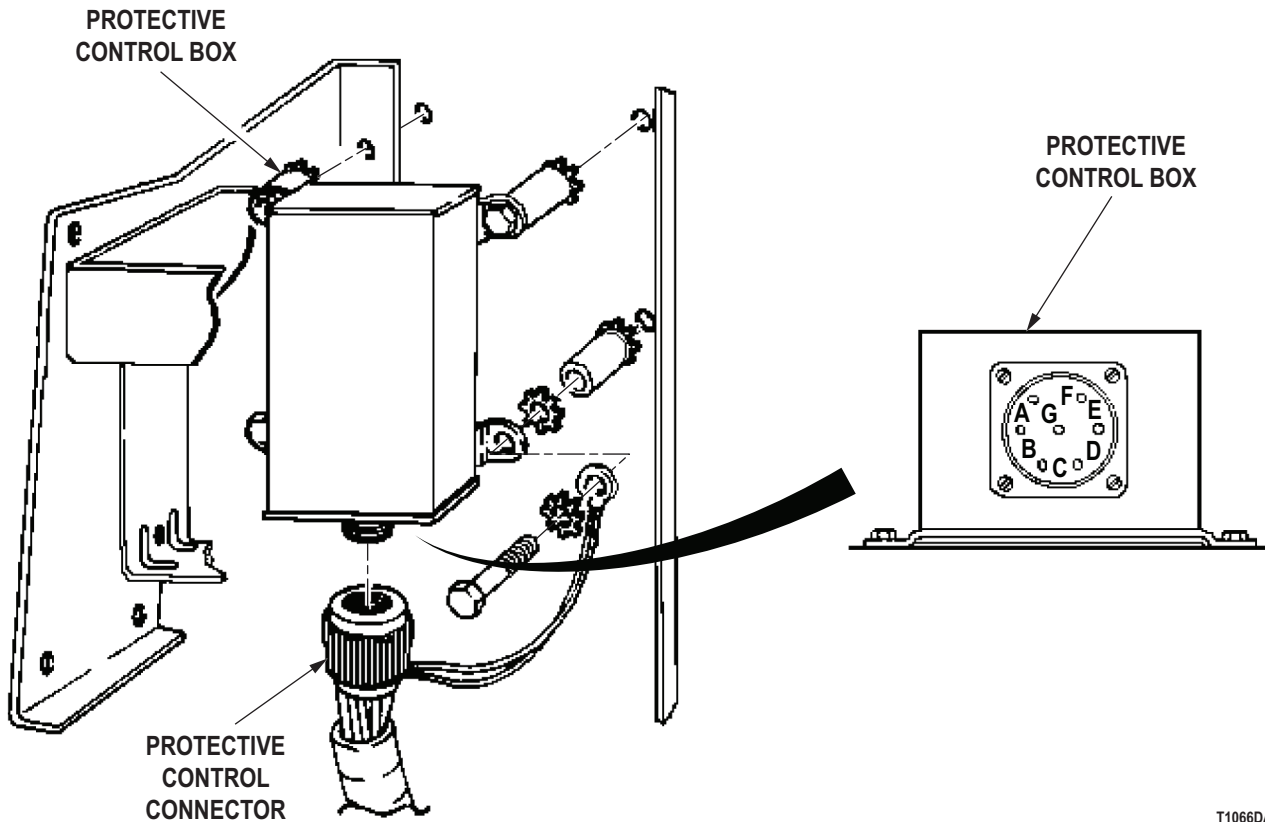

T1066DAA

Figure 5. Protective Control Box Connector.

- a. Connect multimeter red lead to protective control box connector pin B. Refer to point to point schematics.
- b. Connect multimeter black lead to chassis ground.
- c. Meter reading should be greater than 10,000 ohms.

CONDITION/INDICATION

IS THERE NO CONTINUITY BETWEEN PROTECTIVE CONTROL BOX CONNECTOR PINS B AND GROUND?

DECISION

NO - Replace protective control box (Volume 2, WP 0319). Go to Step (10) to verify problem is solved.
 YES - Go to Step (6).

PROTECTIVE CONTROL BOX ASSEMBLY TEST - Continued

STEP

6. IS THERE NO CONTINUITY BETWEEN PROTECTIVE CONTROL BOX CONNECTOR PINS C AND GROUND?

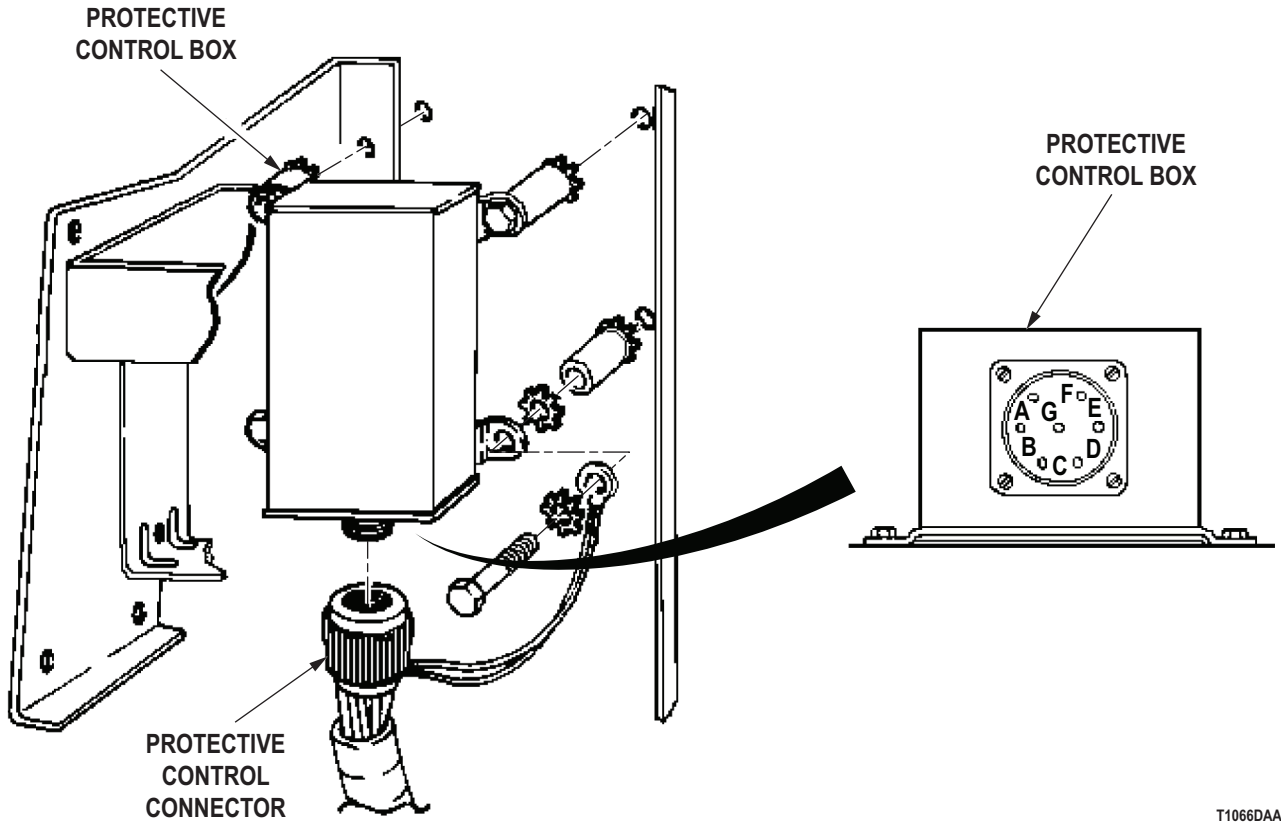

T1066DAA

Figure 6. Protective Control Box Connector.

- a. Connect multimeter red lead to protective control box connector pin C. Refer to point to point schematics.
- b. Connect multimeter black lead to chassis ground.
- c. Meter reading should be greater than 10,000 ohms.

CONDITION/INDICATION

IS THERE NO CONTINUITY BETWEEN PROTECTIVE CONTROL BOX CONNECTOR PINS C AND GROUND?

DECISION

NO - Replace protective control box (Volume 2, WP 0319). Go to Step (10) to verify problem is solved.
 YES - Go to Step (7).

PROTECTIVE CONTROL BOX ASSEMBLY TEST - Continued

STEP

7. IS THERE NO CONTINUITY BETWEEN PROTECTIVE CONTROL BOX CONNECTOR PINS D AND GROUND?

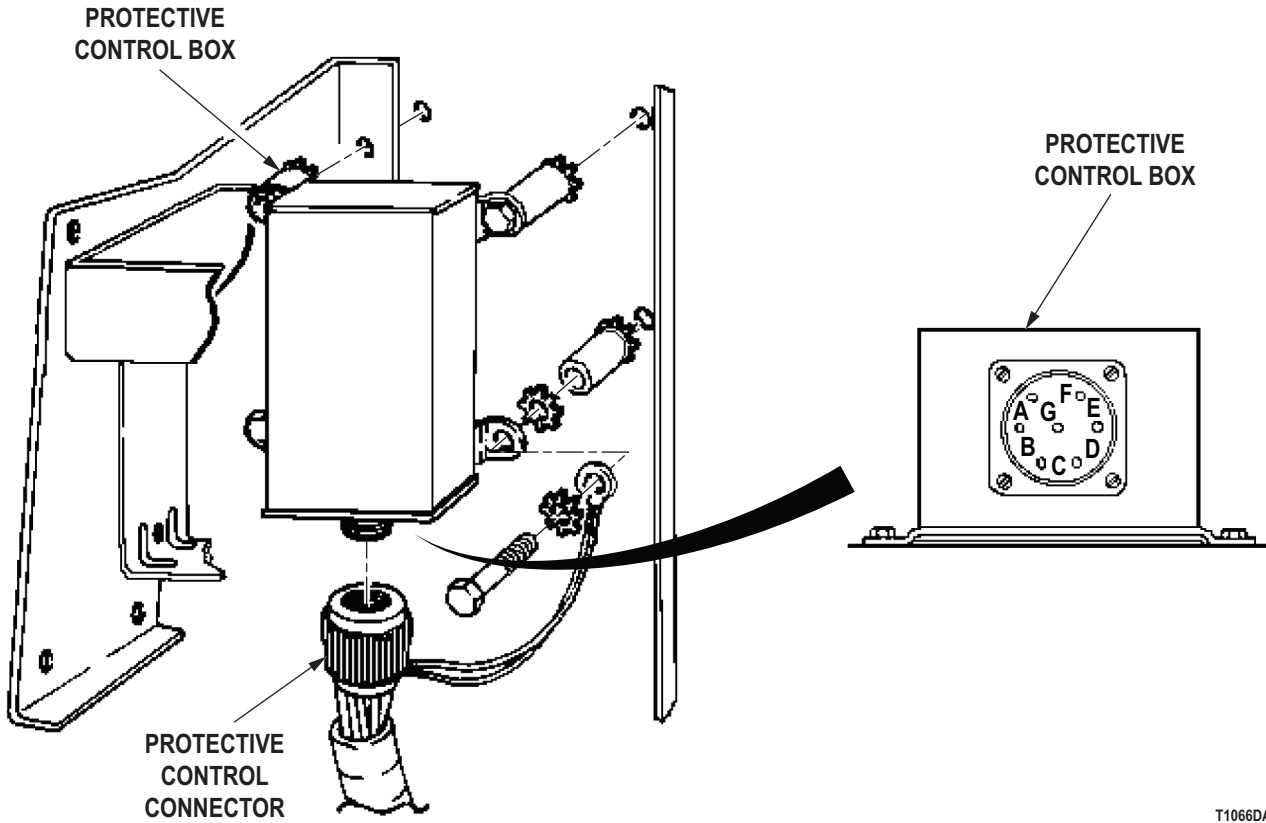

Figure 7. Protective Control Box Connector.

- a. Connect multimeter red lead to protective control box connector pin D. Refer to point to point schematics.
- b. Connect multimeter black lead to chassis ground.
- c. Meter reading should be about 1,000 ohms.

CONDITION/INDICATION

IS THERE NO CONTINUITY BETWEEN PROTECTIVE CONTROL BOX CONNECTOR PINS D AND GROUND?

DECISION

NO - Replace protective control box (Volume 2, WP 0319). Go to Step (10) to verify problem is solved.
 YES - Go to Step (8).

STEP

8. IS THERE CONTINUITY BETWEEN PROTECTIVE CONTROL BOX CONNECTOR C AND D AND NO CONTINUITY BETWEEN B AND D, WHEN 24 VDC IS APPLIED TO PIN A?

PROTECTIVE CONTROL BOX ASSEMBLY TEST - Continued

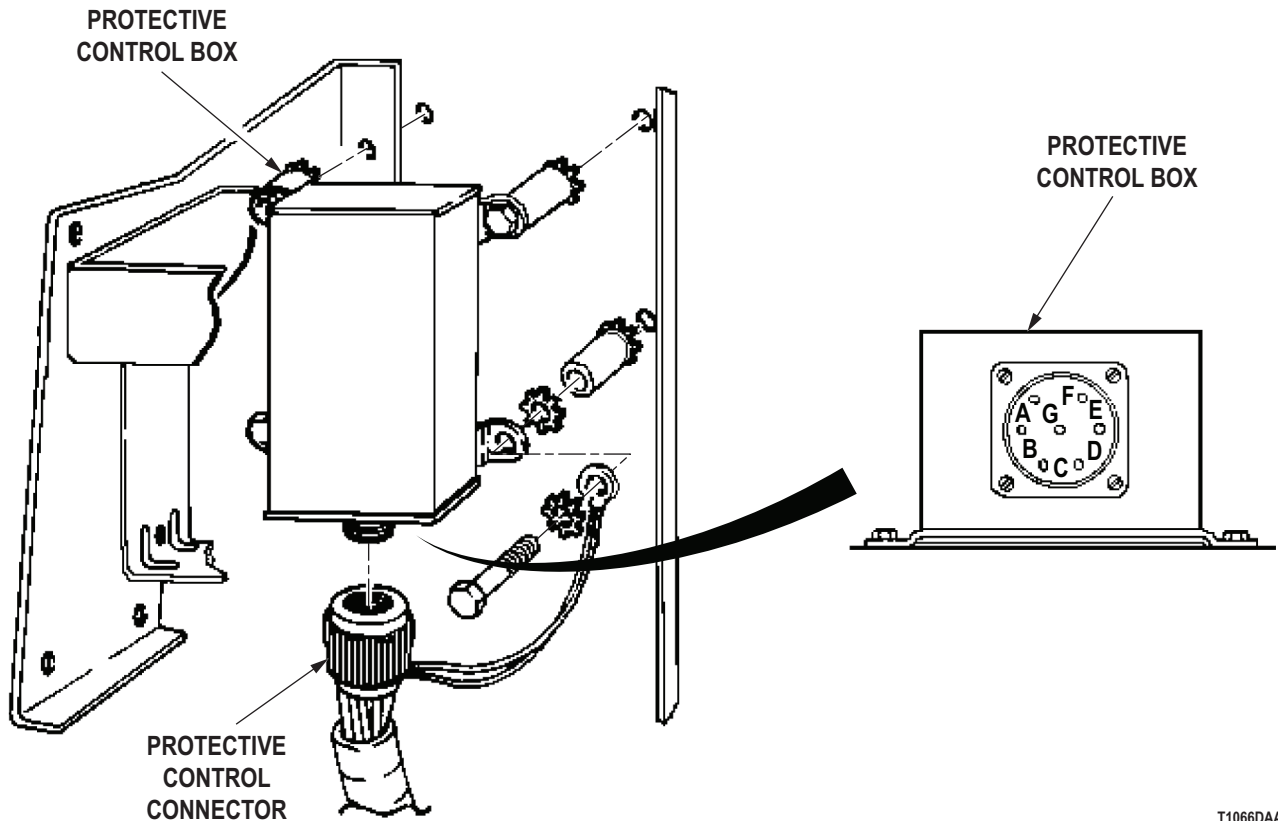

T1066DAA

Figure 8. Protective Control Box Connector.

- a. Apply 24 VDC to pin A.
- b. Connect multimeter red lead to protective control box connector pin C. Refer to point to point schematics.
- c. Connect multimeter black lead to protective control box connector pin D.
- d. Meter reading should be less than 200 ohms. Note reading.
- e. Connect multimeter red lead to protective control box connector pin B.
- f. Connect multimeter black lead to protective control box connector pin D.
- g. Meter reading should be greater than 10,000 ohms.

CONDITION/INDICATION

IS THERE CONTINUITY BETWEEN PROTECTIVE CONTROL BOX CONNECTOR C AND D AND NO CONTINUITY BETWEEN B AND D, WHEN 24 VDC IS APPLIED TO PIN A?

DECISION

NO - Replace protective control box (Volume 2, WP 0319). Go to Step (10) to verify problem is solved.
 YES - Go to Step (9).

PROTECTIVE CONTROL BOX ASSEMBLY TEST - Continued**STEP**

9. IS THERE CONTINUITY BETWEEN PROTECTIVE CONTROL BOX CONNECTOR B AND D, WHEN 24 VDC IS APPLIED TO PIN E?

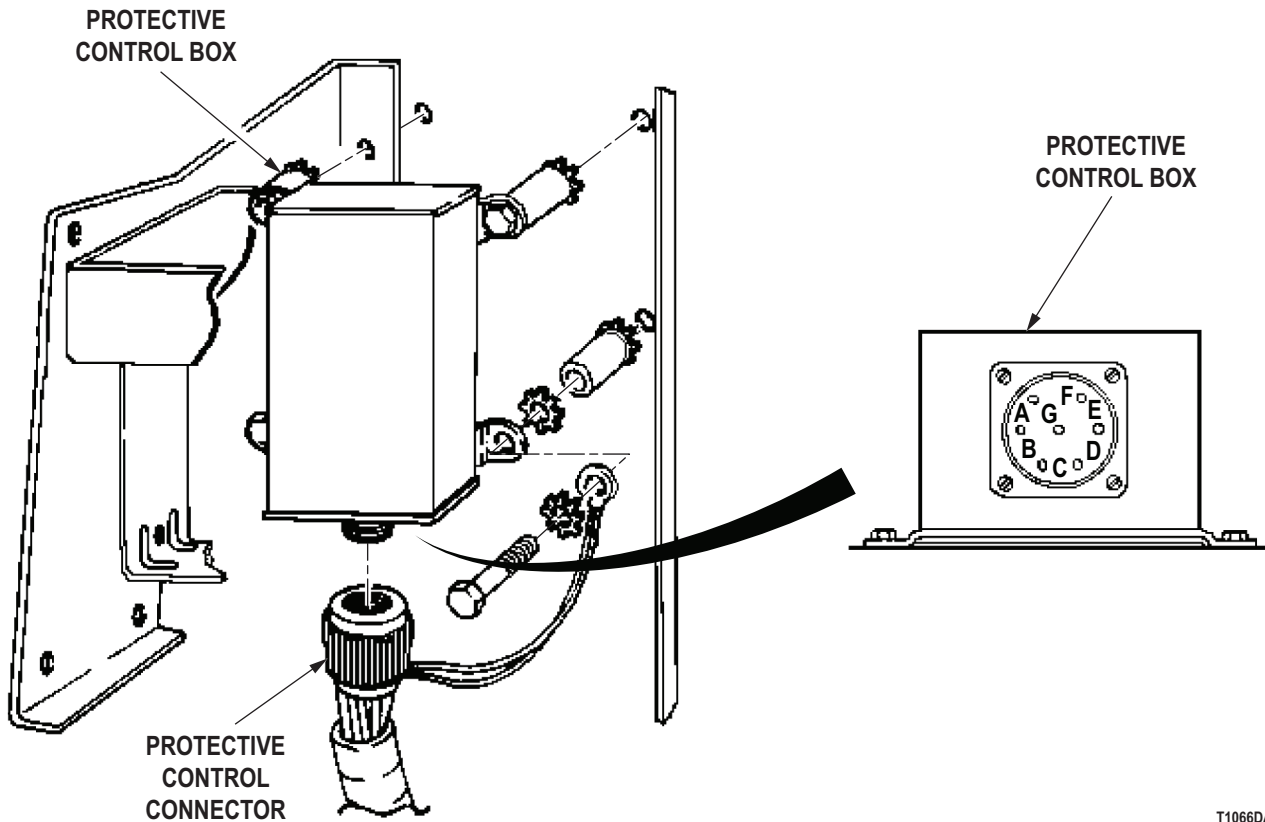

T1066DAA

Figure 9. Protective Control Box Connector.

- Disconnect 24 VDC from pin A.
- Apply 24 VDC to pin E.
- Connect multimeter red lead to protective control box connector pin B. Refer to point to point schematics.
- Connect multimeter black lead to protective control box connector pin D.
- Meter reading should be less than 20 ohms.

CONDITION/INDICATION

IS THERE CONTINUITY BETWEEN PROTECTIVE CONTROL BOX CONNECTOR B AND D, WHEN 24 VDC IS APPLIED TO PIN E?

DECISION

NO - Replace protective control box (Volume 2, WP 0319). Go to Step (10) to verify problem is solved.
 YES - Go to Step (10) to verify problem is solved.

PROTECTIVE CONTROL BOX ASSEMBLY TEST - Continued**STEP**

10. IS YOUR ORIGINAL PROBLEM STILL PRESENT?
- a. Ensure vehicle is returned to normal operating condition.
 - b. Check to see if your original problem still exists.

CONDITION/INDICATION

IS YOUR ORIGINAL PROBLEM STILL PRESENT?

DECISION

YES - Notify supervisor.
NO - Problem fixed.

END OF WORK PACKAGE

**FIELD MAINTENANCE
SPEEDOMETER OR TACHOMETER NOISY OR ERRATIC**

INITIAL SETUP:**Tools and Special Tools**

Tool Kit, General Mechanic's: Automotive
(Volume 5, WP 0826, Table 1, Item 56)

References (cont.)

Volume 5, WP 0815
Volume 5, WP 0817

Personnel Required

(2)

Equipment Condition

Vehicle parked and engine shut down.
(TM 9-2320-272-10)

References

Volume 5, WP 0814

TROUBLESHOOTING PROCEDURE**SPEEDOMETER OR TACHOMETER NOISY OR ERRATIC****NOTE**

Conduct these malfunction tests if the speedometer or tachometer is noisy or erratic. This procedure will check the speedometer/tachometer flexible shaft for binding, kinks, or loose connections, and the speedometer or tachometer for proper operation.

SPEEDOMETER OR TACHOMETER NOISY OR ERRATIC - Continued**STEP**

1. ARE THE SPEEDOMETER AND TACHOMETER FLEXIBLE SHAFTS IN GOOD OPERATING CONDITION?

Visually check the speedometer and tachometer flexible shafts for binding, kinks, or loose connections.

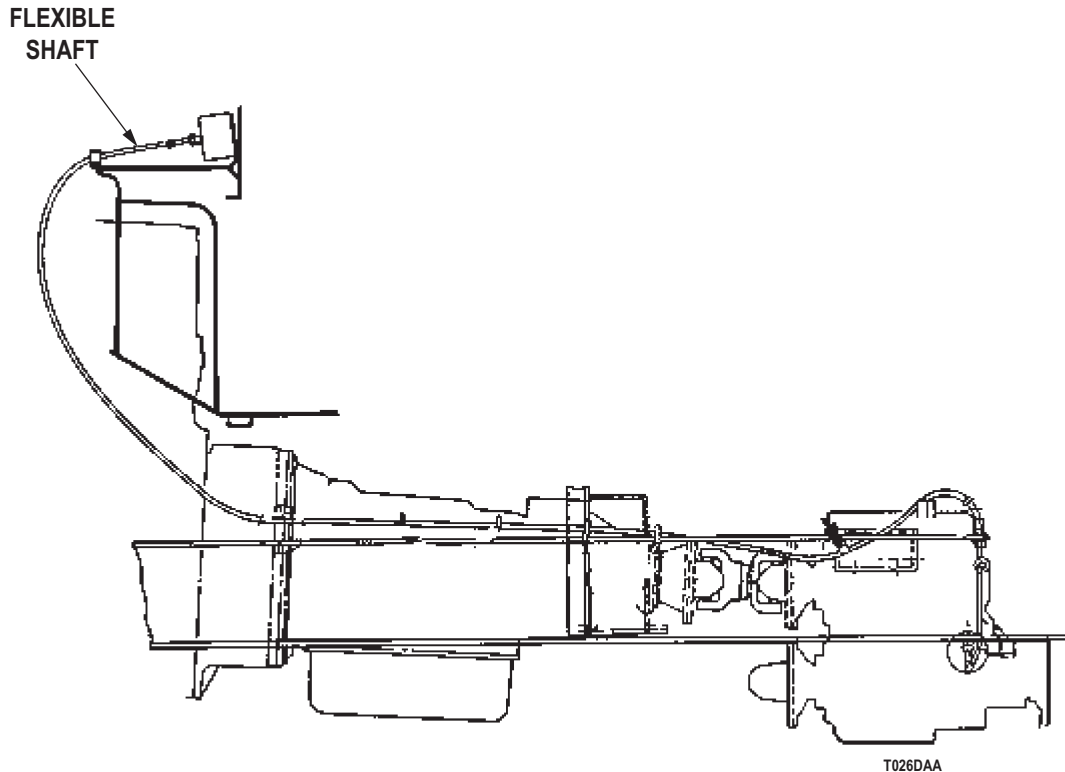

Figure 1. Speedometer and Tachometer Flexible Shafts

CONDITION/INDICATION

ARE THE SPEEDOMETER AND TACHOMETER FLEXIBLE SHAFTS IN GOOD OPERATING CONDITION?

DECISION

YES - Go to Step (2).

NO - Replace speedometer flexible shaft or tighten connections (Volume 5, WP 0814). Go to Step (3) to verify problem is solved.

NO - Replace tachometer flexible shaft or tighten connections (Volume 5, WP 0817). Go to Step (3) to verify problem is solved.

STEP

2. ARE SPEEDOMETER AND TACHOMETER IN GOOD OPERATING CONDITION?

Test operation of tachometer and speedometer.

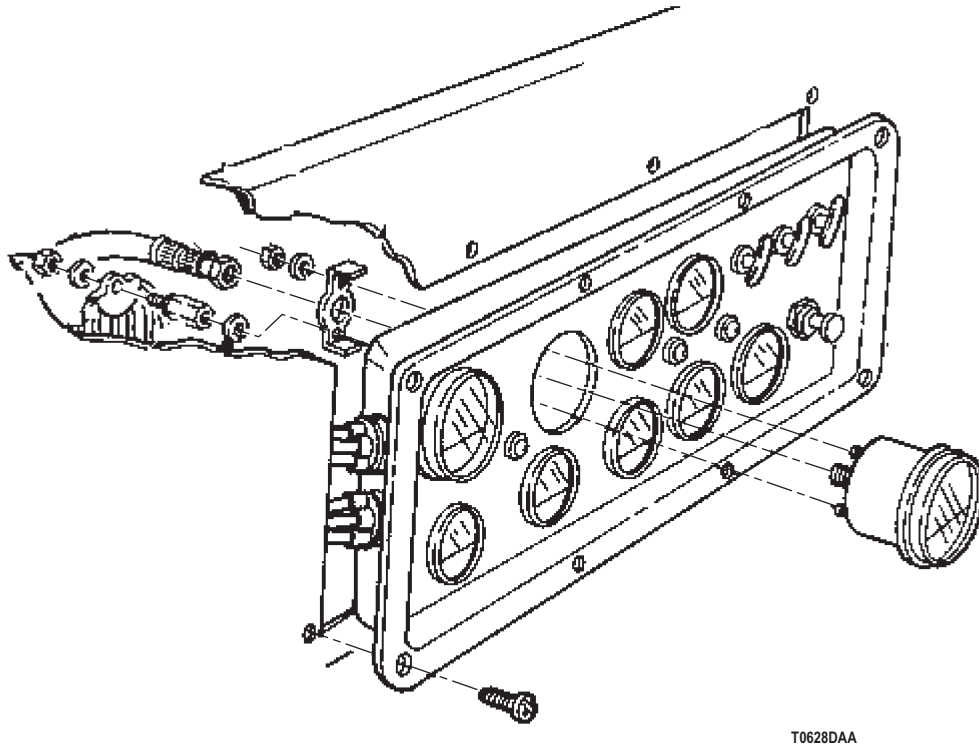
SPEEDOMETER OR TACHOMETER NOISY OR ERRATIC - Continued

T0628DAA

*Figure 2. Speedometer and Tachometer.***CONDITION/INDICATION**

ARE SPEEDOMETER AND TACHOMETER IN GOOD OPERATING CONDITION?

DECISION

NO - Replace defective speedometer or tachometer (Volume 5, WP 0815). Go to Step (3) to verify problem is solved.

YES - Go to Step (3) to verify problem is solved.

STEP

3. IS YOUR ORIGINAL PROBLEM STILL PRESENT?
 - a. Ensure vehicle is returned to normal operating condition.
 - b. Check to see if your original problem still exists.

CONDITION/INDICATION

IS YOUR ORIGINAL PROBLEM STILL PRESENT?

DECISION

YES - Notify supervisor.

NO - Problem fixed.

END OF WORK PACKAGE

**FIELD MAINTENANCE
AIR PRESSURE GAUGE INOPERATIVE**

INITIAL SETUP:**Tools and Special Tools**

Tool Kit, General Mechanic's: Automotive
(Volume 5, WP 0826, Table 1, Item 56)
Test Set, Electronic Systems
(Volume 5, WP 0826, Table 1, Item 51)

Equipment Condition

Vehicle parked and engine shut down.
(TM 9-2320-272-10)
Remove instrument cluster panel.
(Volume 2, WP 0310)

Personnel Required

(2)

References

Point to Point Schematics
Volume 5, WP 0818

TROUBLESHOOTING PROCEDURE**AIR PRESSURE GAUGE INOPERATIVE****NOTE**

Conduct these malfunction tests if air pressure gauge is inoperative. This procedure will check the air pressure gauge for proper operation.

AIR PRESSURE GAUGE INOPERATIVE - Continued**STEP**

1. DOES AIR PRESSURE GAUGE HAVE AIR SUPPLY?
 - a. Check air supply at air pressure gauge.
 - b. Refer to point to point schematics.

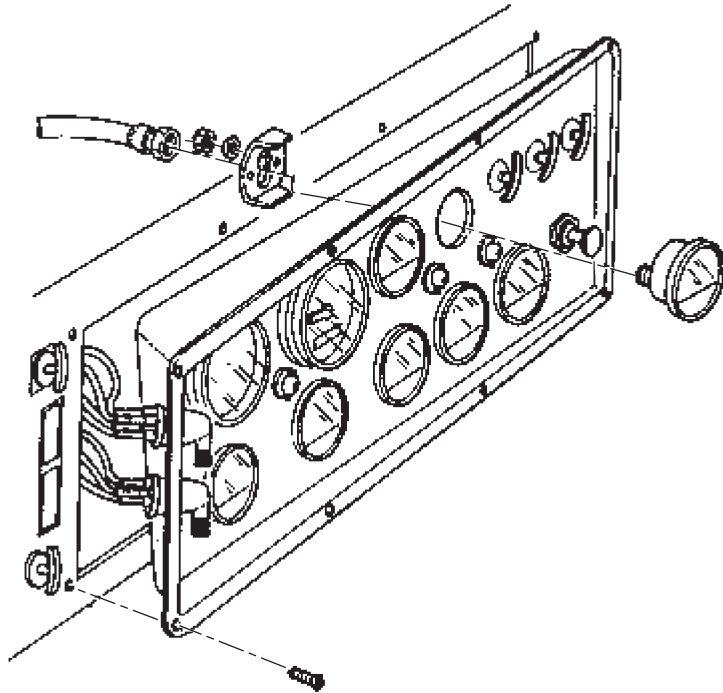

T0629DAA

Figure 1. Air Pressure Gauge.

- c. Make sure air pressure is at normal operating pressure and warning buzzer is not sounding.
 - d. Loosen air supply line from defective air pressure gauge very slowly and listen for air escaping.

CONDITION/INDICATION

DOES AIR PRESSURE GAUGE HAVE AIR SUPPLY?

DECISION

YES - Go to Step (2).

NO - Notify supervisor. It is possible another troubleshooting work package applies.

AIR PRESSURE GAUGE INOPERATIVE - Continued**STEP**

2. IS AIR PRESSURE GAUGE OPERATING PROPERLY?
 - a. Refer to point to point schematics.
 - b. Replace air gauge with one known to be good (Volume 5, WP 0818).
 - c. Start engine.

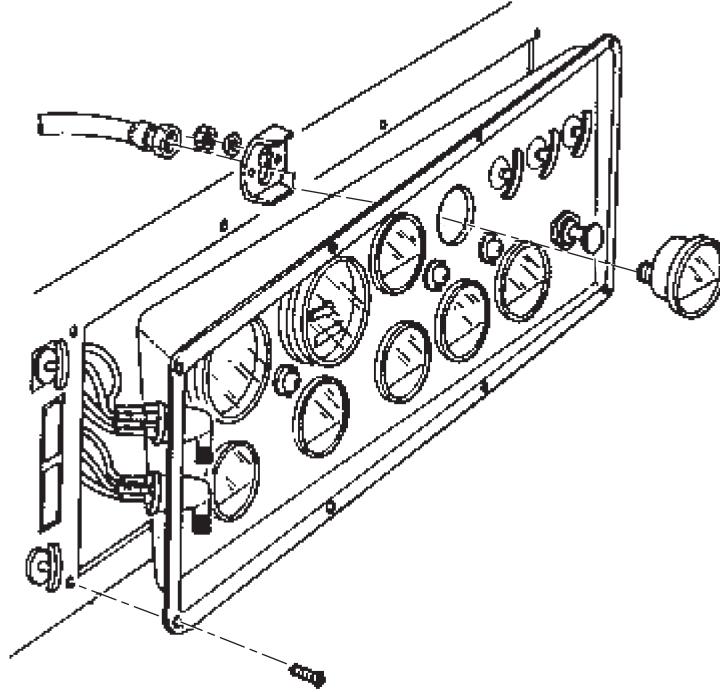

T0629DAA

Figure 2. Air Pressure Gauge.

NOTE

If air pressure reads 30 psi within 5 minutes, air pressure gauge was not operating correctly.

- d. Observe air pressure gauge and verify it reads at least 30 psi within five minutes.

CONDITION/INDICATION

IS AIR PRESSURE GAUGE OPERATING PROPERLY?

DECISION

NO - If test air pressure gauge operates properly, replace defective air pressure gauge (Volume 5, WP 0818). Go to Step (3) to verify problem is solved.

YES - Notify supervisor. It is possible another troubleshooting work package applies.

AIR PRESSURE GAUGE INOPERATIVE - Continued**STEP**

3. IS YOUR ORIGINAL PROBLEM STILL PRESENT?
 - a. Ensure vehicle is returned to normal operating condition.
 - b. Check to see if your original problem still exists.

CONDITION/INDICATION

IS YOUR ORIGINAL PROBLEM STILL PRESENT?

DECISION

YES - Notify supervisor.
NO - Problem fixed.

END OF WORK PACKAGE

FIELD MAINTENANCE
OIL PRESSURE GAUGE INOPERATIVE (OIL LEVEL IS CORRECT)

INITIAL SETUP:**Tools and Special Tools**

Tool Kit, General Mechanic's: Automotive
(Volume 5, WP 0826, Table 1, Item 56)
Multimeter
(Volume 5, WP 0826, Table 1, Item 34)
Test Set, Electronic Systems
(Volume 5, WP 0826, Table 1, Item 51)

References (cont.)

Volume 2, WP 0310
Volume 2, WP 0312
Volume 2, WP 0333
Volume 3, WP 0351
Volume 3, WP 0352

Personnel Required

(2)

Equipment Condition

Vehicle parked and engine shut down.
(TM 9-2320-272-10)

References

Point to Point Schematics

TROUBLESHOOTING PROCEDURE**OIL PRESSURE GAUGE INOPERATIVE (OIL LEVEL IS CORRECT)****NOTE**

Conduct these malfunction tests if oil pressure gauge is inoperative. This procedure will check for a faulty sending unit, wiring harness or gauge.

OIL PRESSURE GAUGE INOPERATIVE (OIL LEVEL IS CORRECT) - Continued**STEP**

1. IS OIL PRESSURE SENDING UNIT OPERATIONAL?
 - a. Place battery switch in the OFF position.
 - b. Refer to point to point schematics.

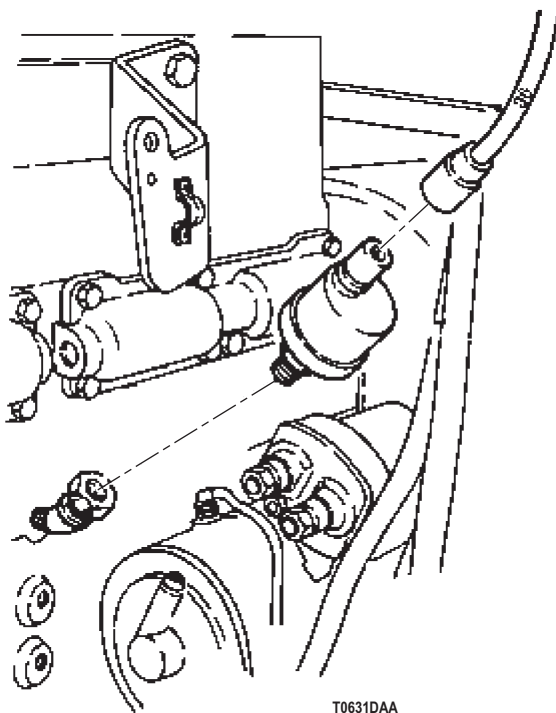

Figure 1. Oil Pressure Sending Unit.

OIL PRESSURE GAUGE INOPERATIVE (OIL LEVEL IS CORRECT) - Continued

- c. Remove circuit 36 wire from oil pressure sending unit.
- d. Place battery switch to ON position.
- e. Have assistant momentarily ground disconnected circuit 36 wire.

NOTE

If oil pressure gauge deflects when grounded, oil pressure sending unit is faulty.

- f. Observe oil pressure gauge for movement.

CONDITION/INDICATION

IS OIL PRESSURE SENDING UNIT OPERATIONAL?

DECISION

YES - Go to Step (2).

NO - Replace oil pressure sending unit (Volume 2, WP 0333). Go to Step (4) to verify problem is solved.

OIL PRESSURE GAUGE INOPERATIVE (OIL LEVEL IS CORRECT) - Continued**STEP**

2. IS CIRCUIT 36 WIRE IN GOOD CONDITION?
 - a. Visually check circuit 36 wire for damage.
 - b. Refer to point to point schematics.
 - c. Remove instrument cluster panel (Volume 2, WP 0310).

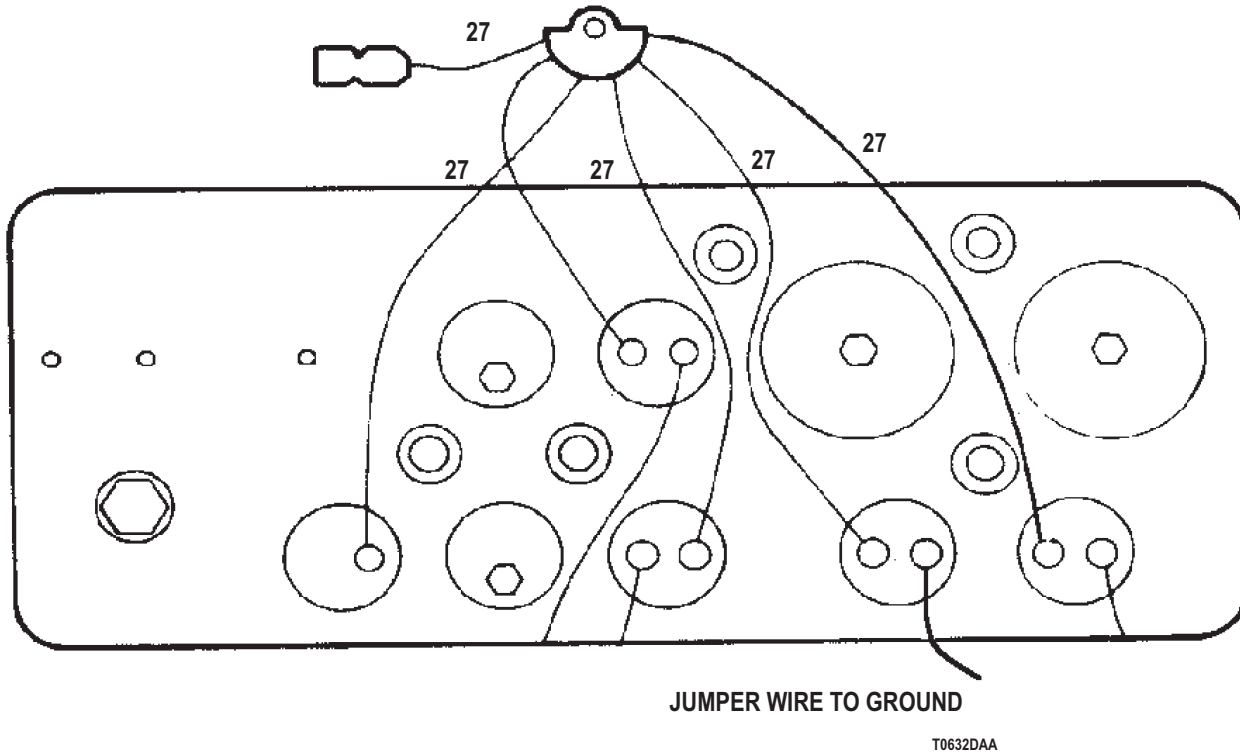

Figure 2. Oil Pressure Gauge Test.

OIL PRESSURE GAUGE INOPERATIVE (OIL LEVEL IS CORRECT) - Continued

- d. Disconnect circuit 36 wire from oil pressure gauge.
- e. Connect jumper wire to open oil pressure gauge terminal.
- f. Place battery switch to ON position.
- g. Momentarily touch jumper wire to vehicle chassis ground.

NOTE

If oil pressure gauge deflects when grounded, circuit 36 wire is faulty.

- h. Observe oil pressure gauge for movement.

CONDITION/INDICATION

IS CIRCUIT 36 WIRE IN GOOD CONDITION?

DECISION

YES - Go to Step (3).

NO - Repair circuit 36 wire (Volume 3, WP 0352). Go to Step (4) to verify problem is solved.

OIL PRESSURE GAUGE INOPERATIVE (OIL LEVEL IS CORRECT) - Continued

STEP

3. IS THERE BATTERY VOLTAGE AT OIL PRESSURE GAUGE?
 - a. Check for battery voltage at oil pressure gauge.
 - b. Place battery switch to the OFF position.
 - c. Refer to point to point schematics.

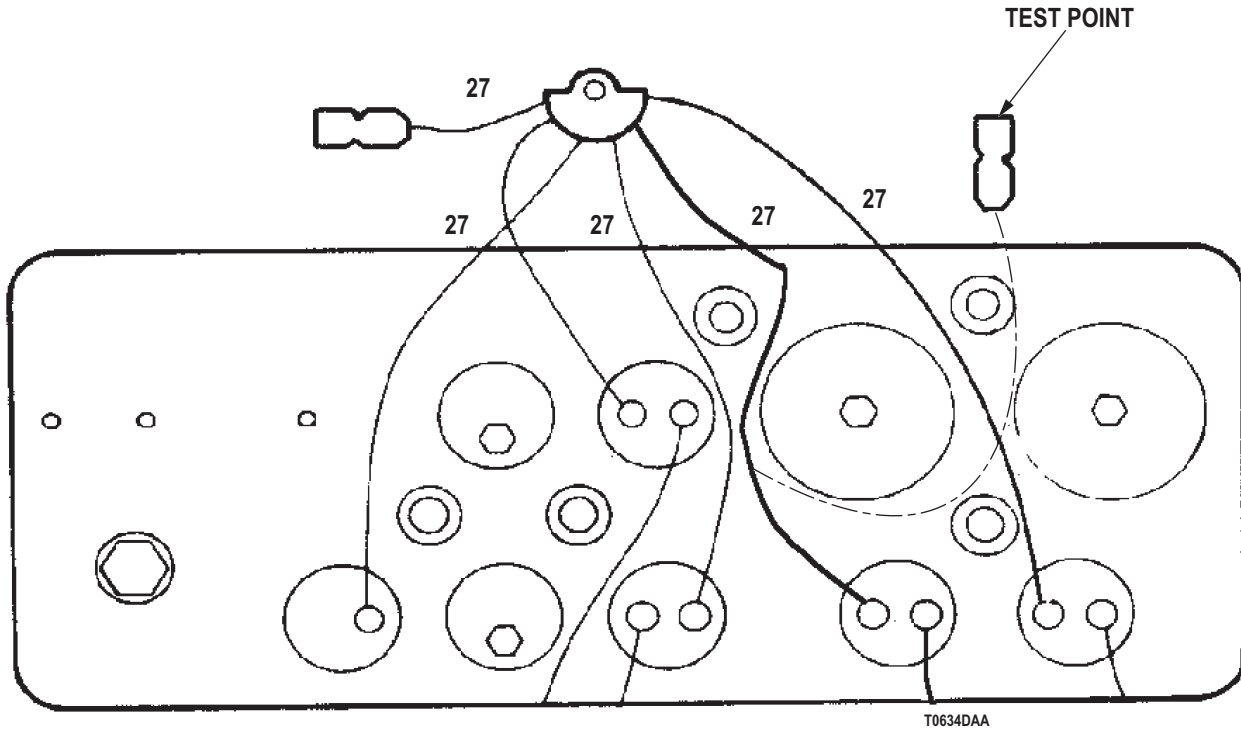

Figure 3. Oil Pressure Gauge Voltage Test.

- d. Disconnect circuit 27 wire from inoperative oil pressure gauge.
- e. Set multimeter to measure VDC.
- f. Place battery switch to ON position.
- g. Connect multimeter probe red lead to disconnected circuit 27 wire.
- h. Connect multimeter probe black lead to vehicle chassis ground.
- i. Meter reading should be greater than or equal to 18 VDC.

CONDITION/INDICATION

IS THERE BATTERY VOLTAGE AT OIL PRESSURE GAUGE?

DECISION

- YES - Replace defective gauge (Volume 2, WP 0312). Go to Step (4) to verify problem is solved.
 NO - Replace instrument cluster wiring harness (Volume 3, WP 0351). Go to Step (4) to verify problem is solved.

OIL PRESSURE GAUGE INOPERATIVE (OIL LEVEL IS CORRECT) - Continued**STEP**

4. IS YOUR ORIGINAL PROBLEM STILL PRESENT?
 - a. Ensure vehicle is returned to normal operating condition.
 - b. Check to see if your original problem still exists.

CONDITION/INDICATION

IS YOUR ORIGINAL PROBLEM STILL PRESENT?

DECISION

YES - Notify supervisor.
NO - Problem fixed.

END OF WORK PACKAGE

**FIELD MAINTENANCE
ALL GAUGES INOPERATIVE**

INITIAL SETUP:**Tools and Special Tools**

Tool Kit, General Mechanic's: Automotive
(Volume 5, WP 0826, Table 1, Item 56)
Multimeter
(Volume 5, WP 0826, Table 1, Item 34)
Test Set, Electronic Systems
(Volume 5, WP 0826, Table 1, Item 51)

References (cont.)

Volume 2, WP 0307
Volume 2, WP 0310
Volume 3, WP 0352
Volume 3, WP 0357
Volume 3, WP 0358

Personnel Required

(2)

Equipment Condition

Vehicle parked and engine shut down.
(TM 9-2320-272-10)

References

Point to Point Schematics

TROUBLESHOOTING PROCEDURE**ALL GAUGES INOPERATIVE****NOTE**

Conduct these malfunction tests if all gauges are inoperative. This procedure will check for instrument panel voltage feed, defective circuit breaker, defective gauge and instrument cluster wire assembly.

ALL GAUGES INOPERATIVE - Continued**STEP**

1. IS INSTRUMENT CLUSTER CIRCUIT BREAKER BATTERY VOLTAGE FEED CORRECT?
 - a. Place battery switch to the OFF position.
 - b. Check instrument cluster voltage feed.
 - c. Refer to point to point schematics.

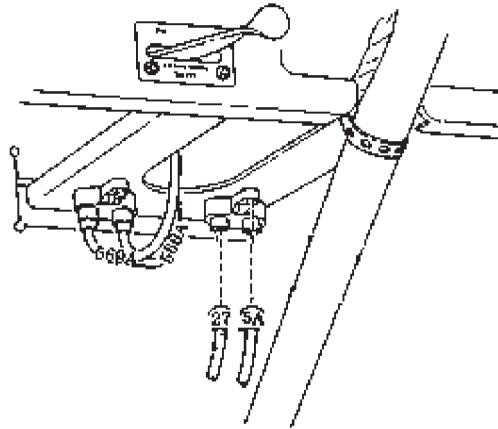

T0082DAA

Figure 1. Circuit Breaker.

- d. Disconnect circuit 5A wire at circuit breaker.
- e. Set multimeter to measure VDC.
- f. Place battery switch to ON position.
- g. Connect multimeter red lead to disconnected circuit 5A wire.
- h. Connect multimeter black lead to vehicle chassis ground.
- i. Meter reading should be greater than or equal to 18 VDC.

CONDITION/INDICATION

IS INSTRUMENT CLUSTER CIRCUIT BREAKER BATTERY VOLTAGE FEED CORRECT?

DECISION

YES - Go to Step (2).

NO - Repair or replace circuit 5A wire (Volume 3, WP 0352). Go to Step (4) to verify problem is solved.

STEP

2. IS CIRCUIT BREAKER IN GOOD OPERATING CONDITION?
 - a. Check for battery voltage at circuit breaker terminal.
 - b. Place battery switch to the OFF position.

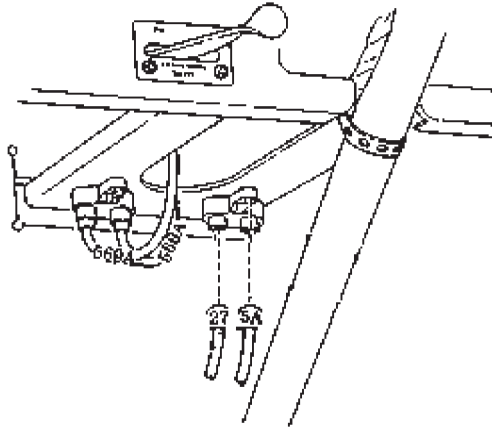
ALL GAUGES INOPERATIVE - Continued

T0082DAA

Figure 2. Circuit Breaker Test.

- c. Refer to point to point schematics.
- d. Reconnect circuit 5A wire and disconnect circuit 27 wire from circuit breaker.
- e. Place battery switch to ON position.
- f. Connect multimeter red lead to circuit 27 circuit breaker terminal.
- g. Connect multimeter black lead to vehicle chassis ground.
- h. Meter reading should be greater than or equal to 18 VDC.

CONDITION/INDICATION

IS CIRCUIT BREAKER IN GOOD OPERATING CONDITION?

DECISION

YES - Go to Step (3).

NO - Replace circuit breaker (Volume 2, WP 0307). Go to Step (4) to verify problem is solved.

ALL GAUGES INOPERATIVE - Continued

STEP

3. IS THERE BATTERY VOLTAGE AT CIRCUIT 27 POWER WIRE?
 - a. Check for battery voltage at instrument cluster circuit 27 power wire.
 - b. Place battery switch to the OFF position.
 - c. Remove instrument cluster panel (Volume 2, WP 0310).
 - d. Refer to point to point schematics.

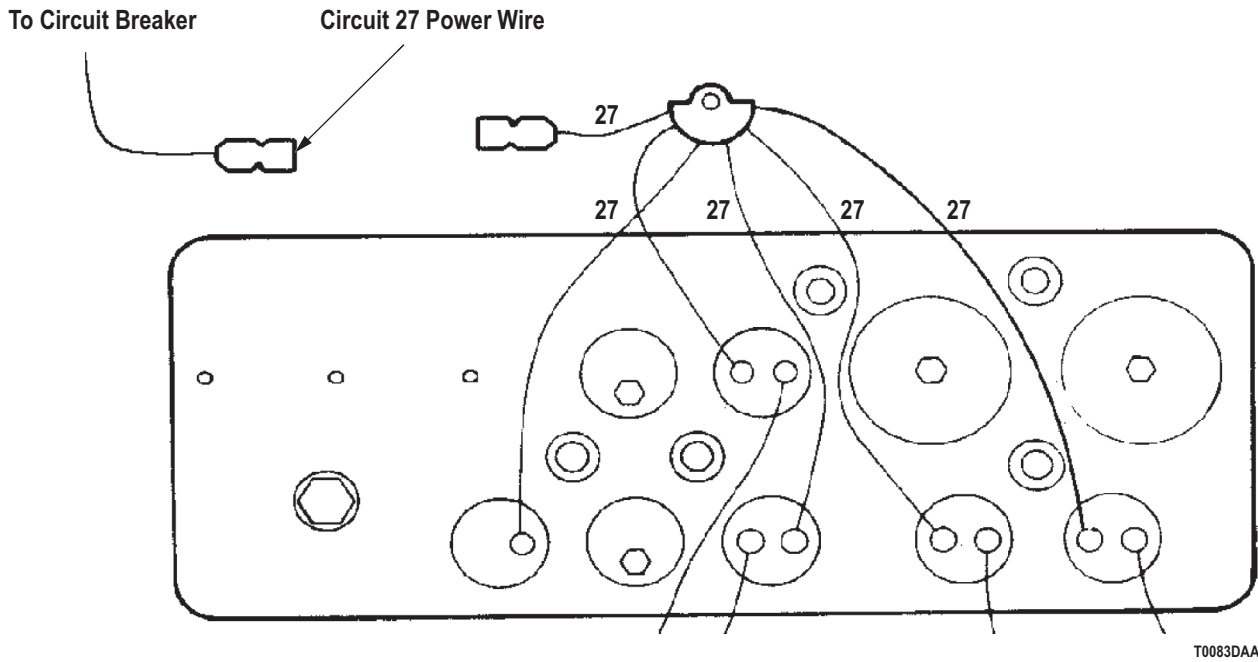

Figure 3. Circuit 27 Wire Test.

- e. Disconnect instrument cluster wire assembly from circuit 27 power wire.
- f. Place battery switch to ON position.
- g. Connect multimeter red lead to disconnected circuit 27 wire.
- h. Connect multimeter black lead to vehicle chassis ground.
- i. Meter reading should be greater than or equal to 18 VDC.

CONDITION/INDICATION

IS THERE BATTERY VOLTAGE AT CIRCUIT 27 POWER WIRE?

DECISION

YES - Notify supervisor. Action may not be possible at this level of maintenance.
 NO - Replace front wiring harness M939/A1 (Volume 3, WP 0357), M939A2 (Volume 3, WP 0358). Go to Step (4) to verify problem is solved.

ALL GAUGES INOPERATIVE - Continued**STEP**

4. IS YOUR ORIGINAL PROBLEM STILL PRESENT?
 - a. Ensure vehicle is returned to normal operating condition.
 - b. Check to see if your original problem still exists.

CONDITION/INDICATION

IS YOUR ORIGINAL PROBLEM STILL PRESENT?

DECISION

YES - Notify supervisor.
NO - Problem fixed.

END OF WORK PACKAGE

**FIELD MAINTENANCE
TRANSMISSION TEMPERATURE GAUGE INOPERATIVE**

INITIAL SETUP:**Tools and Special Tools**

Tool Kit, General Mechanic's: Automotive
(Volume 5, WP 0826, Table 1, Item 56)
Multimeter
(Volume 5, WP 0826, Table 1, Item 34)
Test Set, Electronic Systems
(Volume 5, WP 0826, Table 1, Item 51)

References (cont.)

Volume 2, WP 0310
Volume 2, WP 0312
Volume 2, WP 0341
Volume 3, WP 0351
Volume 3, WP 0352

Personnel Required

(2)

Equipment Condition

Vehicle parked and engine shut down.
(TM 9-2320-272-10)

References

Point to Point Schematics

TROUBLESHOOTING PROCEDURE**TRANSMISSION TEMPERATURE GAUGE INOPERATIVE****NOTE**

Conduct these malfunction tests if transmission temperature gauge is inoperative. This procedure will check for a faulty sending unit, wiring harness or gauge.

TRANSMISSION TEMPERATURE GAUGE INOPERATIVE - Continued**STEP**

1. IS TRANSMISSION TEMPERATURE SENDING UNIT OPERATIONAL?
 - a. Place battery switch in the OFF position.
 - b. Refer to point to point schematics.

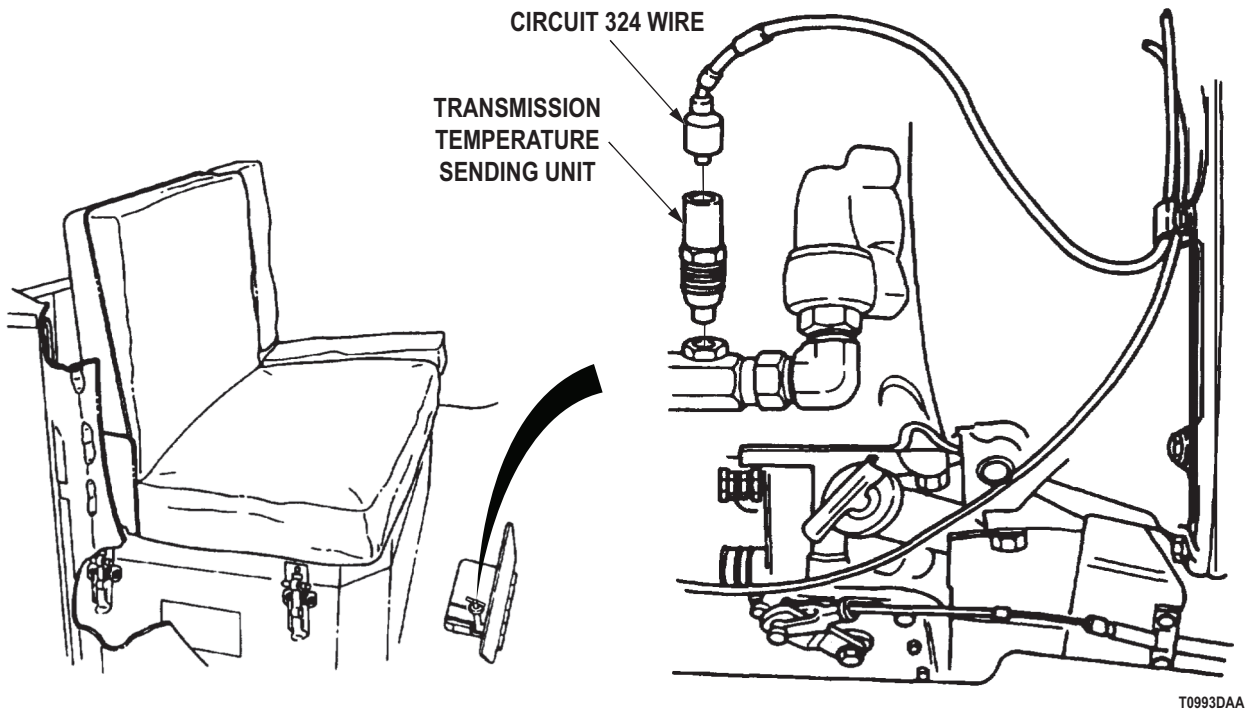

Figure 1. Transmission Temperature Sending Unit.

- c. Remove circuit 324 wire from transmission temperature sending unit.
- d. Place battery switch to ON position.
- e. Have assistant momentarily ground disconnected circuit 324 wire.

NOTE

If transmission temperature gauge deflects when grounded, transmission temperature sending unit is faulty.

- f. Observe transmission temperature gauge for movement.

CONDITION/INDICATION

IS TRANSMISSION TEMPERATURE SENDING UNIT OPERATIONAL?

DECISION

YES - Go to Step (2).

NO - Replace transmission temperature sending unit (Volume 2, WP 0341). Go to Step (4) to verify problem is solved.

TRANSMISSION TEMPERATURE GAUGE INOPERATIVE - Continued**STEP**

2. IS CIRCUIT 324 WIRE IN GOOD CONDITION?
 - a. Visually check circuit 324 wire for damage.
 - b. Refer to point to point schematics.
 - c. Remove instrument cluster panel (Volume 2, WP 0310).

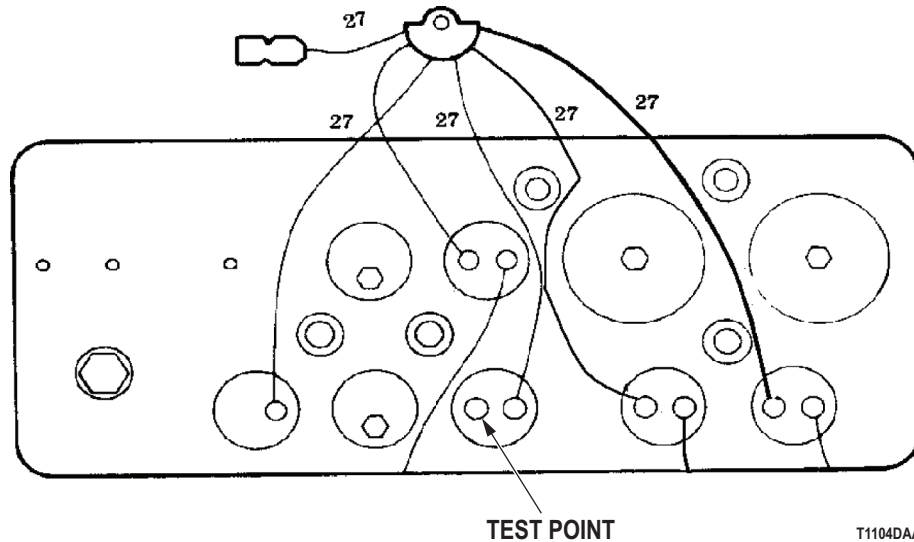

Figure 2. Transmission Temperature Gauge Wire 324.

- d. Disconnect circuit 324 wire from transmission temperature gauge.
- e. Connect jumper wire to open transmission temperature gauge terminal.
- f. Place battery switch to ON position.
- g. Momentarily touch jumper wire to vehicle chassis ground.

NOTE

If transmission temperature gauge deflects when grounded, circuit 324 wire is faulty.

- h. Observe transmission temperature gauge for movement.

CONDITION/INDICATION

IS CIRCUIT 324 WIRE IN GOOD CONDITION?

DECISION

YES - Go to Step (3).

NO - Repair circuit 324 wire (Volume 3, WP 0352). Go to Step (4) to verify problem is solved.

TRANSMISSION TEMPERATURE GAUGE INOPERATIVE - Continued**STEP**

3. IS THERE BATTERY VOLTAGE AT TRANSMISSION TEMPERATURE GAUGE?
 - a. Check for battery voltage at transmission temperature gauge.
 - b. Place battery switch to the OFF position.
 - c. Refer to point to point schematics.

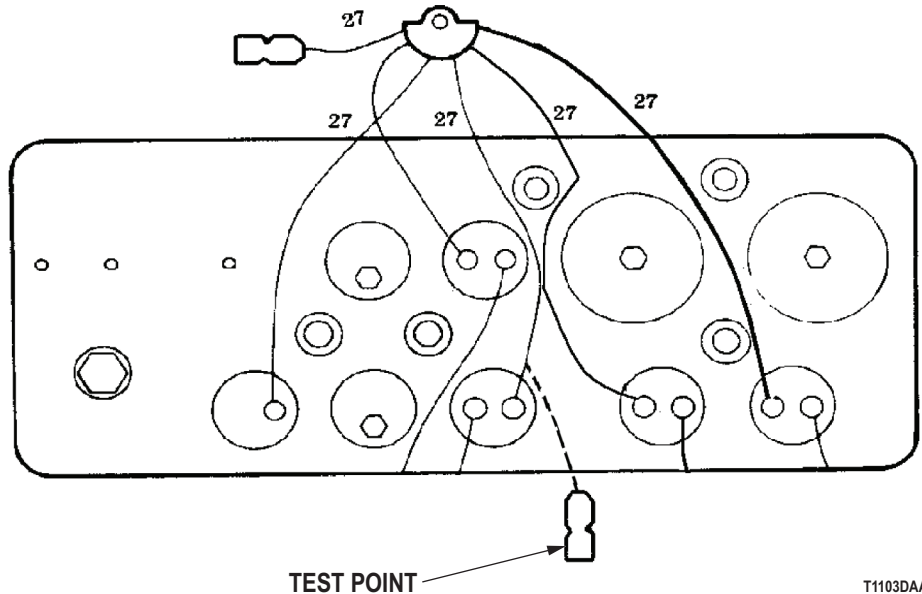

Figure 3. Transmission Temperature Gauge Wire 27.

- d. Disconnect circuit 27 wire from inoperative transmission temperature gauge.
- e. Place battery switch to ON position.
- f. Set multimeter to measure VDC.
- g. Connect multimeter red lead to disconnected circuit 27 wire.
- h. Connect multimeter black lead to vehicle chassis ground.
- i. Meter reading should be greater than or equal to 18 VDC.

CONDITION/INDICATION

IS THERE BATTERY VOLTAGE AT TRANSMISSION TEMPERATURE GAUGE?

DECISION

- YES - Replace defective gauge (Volume 2, WP 0312). Go to Step (4) to verify problem is solved.
 NO - Replace instrument cluster wiring harness (Volume 3, WP 0351). Go to Step (4) to verify problem is solved.

TRANSMISSION TEMPERATURE GAUGE INOPERATIVE - Continued**STEP**

4. IS YOUR ORIGINAL PROBLEM STILL PRESENT?
 - a. Ensure vehicle is returned to normal operating condition.
 - b. Check to see if your original problem still exists.

CONDITION/INDICATION

IS YOUR ORIGINAL PROBLEM STILL PRESENT?

DECISION

YES - Notify supervisor.
NO - Problem fixed.

END OF WORK PACKAGE

**FIELD MAINTENANCE
TEMPERATURE GAUGE INOPERATIVE (COOLANT)**

INITIAL SETUP:**Tools and Special Tools**

Tool Kit, General Mechanic's: Automotive
(Volume 5, WP 0826, Table 1, Item 56)
Multimeter
(Volume 5, WP 0826, Table 1, Item 34)
Test Set, Electronic Systems
(Volume 5, WP 0826, Table 1, Item 51)

References (cont.)

Volume 2, WP 0310
Volume 2, WP 0312
Volume 2, WP 0334
Volume 3, WP 0351
Volume 3, WP 0352

Personnel Required

(2)

Equipment Condition

Vehicle parked and engine shut down.
(TM 9-2320-272-10)

References

Point to Point Schematics

TROUBLESHOOTING PROCEDURE**TEMPERATURE GAUGE INOPERATIVE (COOLANT)****NOTE**

Conduct these malfunction tests if coolant temperature gauge is inoperative. This procedure will check for inoperative coolant temperature sending unit, faulty circuit 33 wire, defective gauge or instrument cluster wiring assembly.

TEMPERATURE GAUGE INOPERATIVE (COOLANT) - Continued

STEP

1. IS COOLANT TEMPERATURE SENDING UNIT OPERATIONAL?

- a. Place battery switch in the OFF position.
- b. Refer to point to point schematics.

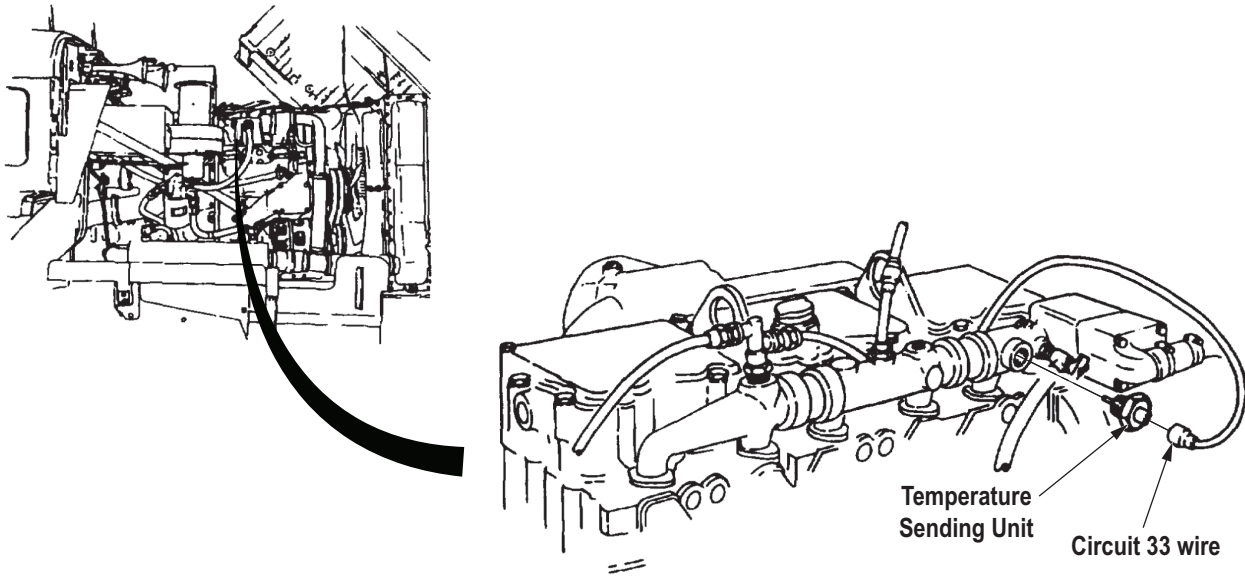

M939/A1 VEHICLES

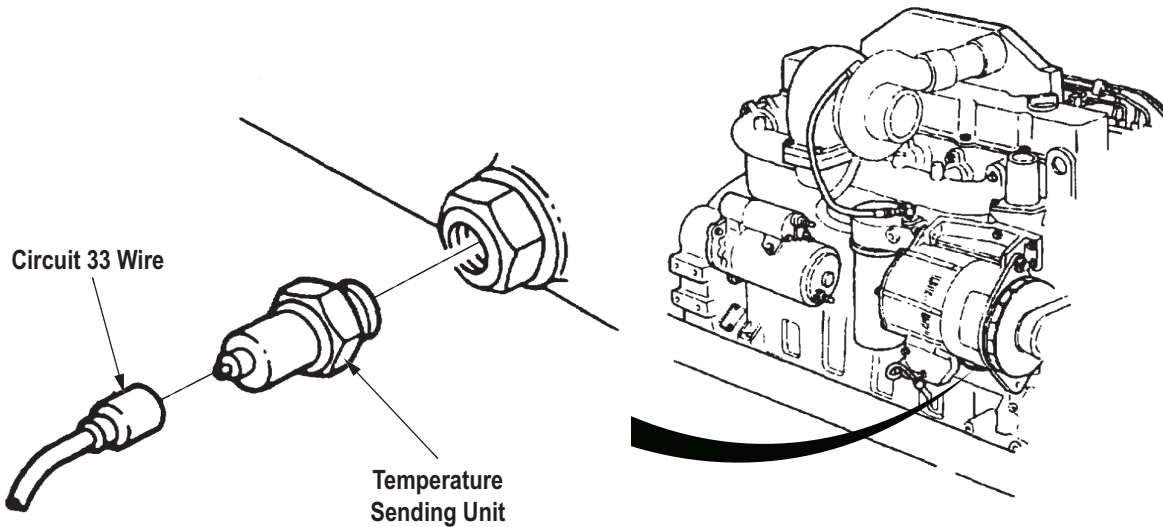

M939/A2 VEHICLES

T0085DAA

Figure 1. Coolant Temperature Sending Unit.

- c. Remove circuit 33 wire from coolant temperature sending unit.
- d. Place battery switch to ON position.

TEMPERATURE GAUGE INOPERATIVE (COOLANT) - Continued

- e. Have assistant momentarily ground disconnected circuit 33 wire.

NOTE

If coolant temperature gauge deflects when grounded, coolant temperature sending unit is faulty.

- f. Observe coolant temperature gauge for movement.

CONDITION/INDICATION

IS COOLANT TEMPERATURE SENDING UNIT OPERATIONAL?

DECISION

YES - Go to Step (2).

NO - Replace coolant temperature sending unit (Volume 2, WP 0334). Go to Step (4) to verify problem is solved.

TEMPERATURE GAUGE INOPERATIVE (COOLANT) - Continued

STEP

- 2. IS CIRCUIT 33 WIRE IN GOOD CONDITION?
 - a. Visually check circuit 33 wire for damage.
 - b. Refer to point to point schematics.
 - c. Remove instrument cluster panel (Volume 2, WP 0310).

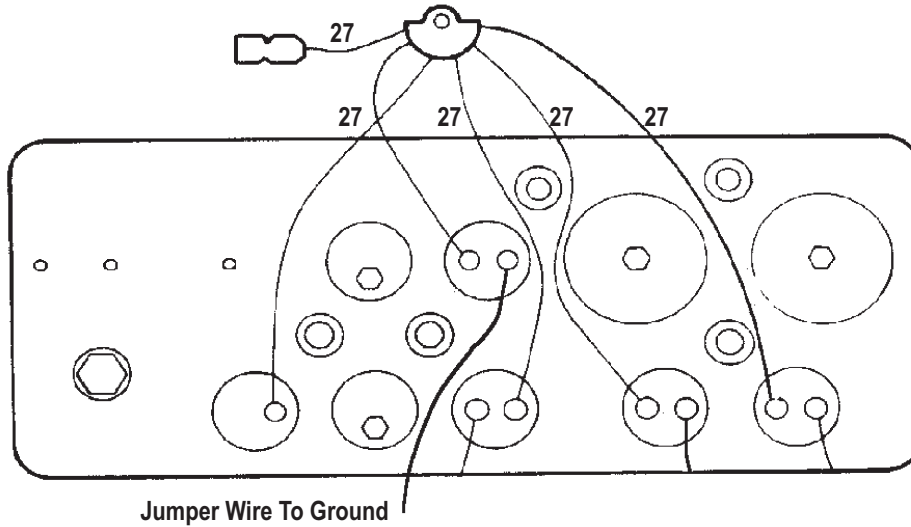

T0086DAA

Figure 2. Coolant Temperature Gauge Test.

- d. Disconnect circuit 33 wire from coolant temperature gauge.
- e. Connect jumper wire to open coolant temperature gauge terminal.
- f. Place battery switch to ON position.
- g. Momentarily touch jumper wire to vehicle chassis ground.

NOTE

If coolant temperature gauge deflects when grounded, circuit 33 wire is faulty.

- h. Observe coolant temperature gauge for movement.

CONDITION/INDICATION

IS CIRCUIT 33 WIRE IN GOOD CONDITION?

DECISION

- YES - Go to Step (3).
- NO - Repair circuit 33 wire (Volume 3, WP 0352). Go to Step (4) to verify problem is solved.

TEMPERATURE GAUGE INOPERATIVE (COOLANT) - Continued**STEP**

3. IS THERE BATTERY VOLTAGE AT COOLANT TEMPERATURE GAUGE?
 - a. Check for battery voltage at coolant temperature gauge.
 - b. Place battery switch to the OFF position.
 - c. Refer to point to point schematics.

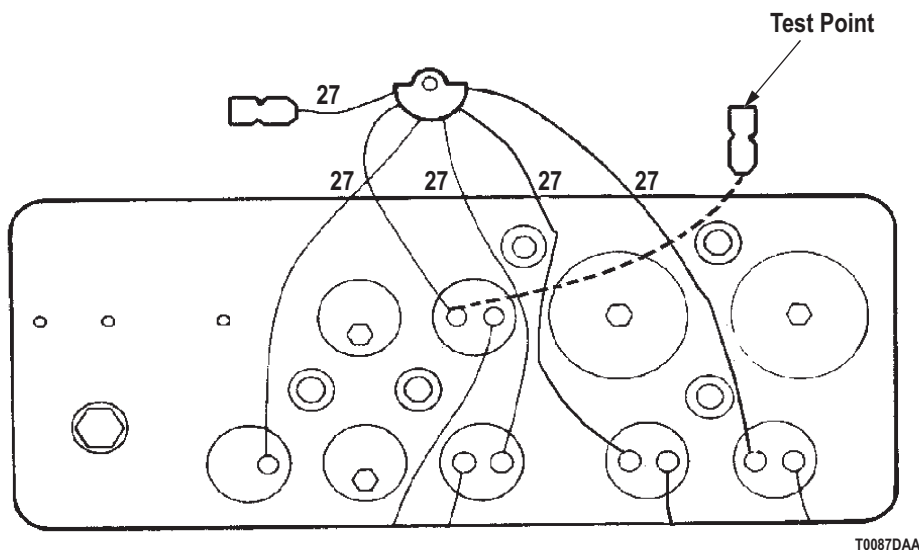

Figure 3. Coolant Temperature Gauge Voltage Test.

- d. Disconnect circuit 27 wire from inoperative coolant temperature gauge.
- e. Place battery switch to ON position.
- f. Set multimeter to measure VDC.
- g. Connect multimeter red lead to disconnected circuit 27 wire.
- h. Connect multimeter black lead to vehicle chassis ground.
- i. Meter reading should be greater than or equal to 18 VDC.

CONDITION/INDICATION

IS THERE BATTERY VOLTAGE AT COOLANT TEMPERATURE GAUGE?

DECISION

YES - Replace defective gauge (Volume 2, WP 0312). Go to Step (4) to verify problem is solved.

NO - Replace instrument cluster wiring harness (Volume 3, WP 0351). Go to Step (4) to verify problem is solved.

TEMPERATURE GAUGE INOPERATIVE (COOLANT) - Continued**STEP**

4. IS YOUR ORIGINAL PROBLEM STILL PRESENT?
 - a. Ensure vehicle is returned to normal operating condition.
 - b. Check to see if your original problem still exists.

CONDITION/INDICATION

IS YOUR ORIGINAL PROBLEM STILL PRESENT?

DECISION

YES - Notify supervisor.
NO - Problem fixed.

END OF WORK PACKAGE

**FIELD MAINTENANCE
FUEL GAUGE INOPERATIVE**

INITIAL SETUP:**Tools and Special Tools**

Tool Kit, General Mechanic's: Automotive
(Volume 5, WP 0826, Table 1, Item 56)
Multimeter
(Volume 5, WP 0826, Table 1, Item 34)
Test Set, Electronic Systems
(Volume 5, WP 0826, Table 1, Item 51)

References (cont.)

Volume 2, WP 0310
Volume 2, WP 0312
Volume 2, WP 0314
Volume 2, WP 0332
Volume 3, WP 0351
Volume 3, WP 0352

Personnel Required

(2)

Equipment Condition

Vehicle parked and engine shut down.
(TM 9-2320-272-10)

References

Point to Point Schematics

TROUBLESHOOTING PROCEDURE**FUEL GAUGE INOPERATIVE****WARNING**

Do not perform testing near fuel tank with fill cap or sending unit removed. Fuel may ignite. Failure to comply may result in injury or death to personnel.

NOTE

Conduct these malfunction tests if fuel gauge is inoperative. This procedure will check for a faulty sending unit, faulty circuit 28 or 29 wire, defective gauge or instrument cluster wiring assembly.

FUEL GAUGE INOPERATIVE - Continued**STEP**

1. IS FUEL LEVEL SENDING UNIT OPERATIONAL?
 - a. Place battery switch in the OFF position.
 - b. Refer to point to point schematics.

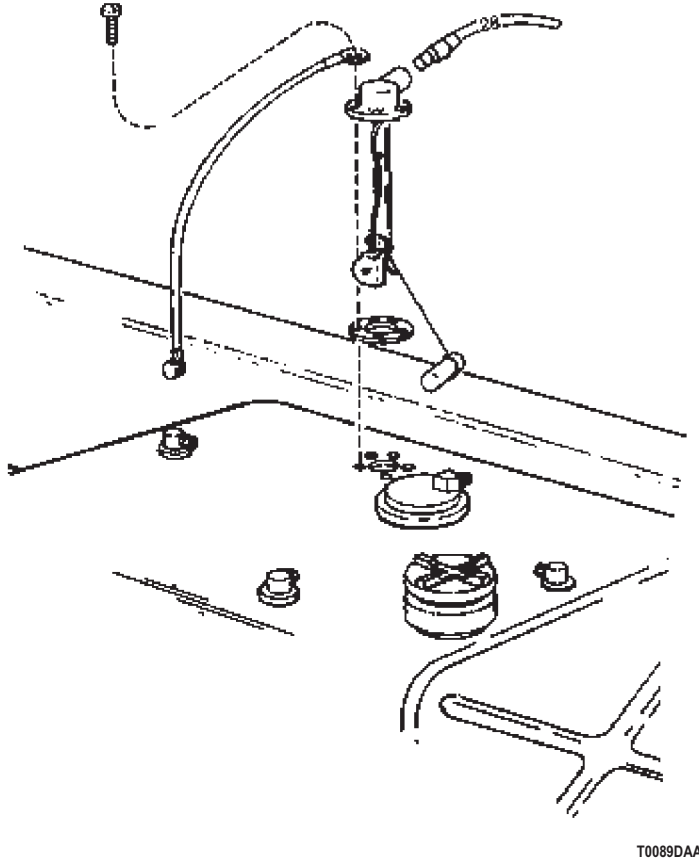

Figure 1. Fuel Level Sending Unit.

NOTE

Make sure fuel selector switch is set to sending unit side being tested.

- c. Remove circuit wire from inoperative fuel sending unit (wire 28 for left hand tank, wire 29 for right hand tank).
- d. Place battery switch to ON position.
- e. Have assistant momentarily ground disconnected circuit 28 or 29 wire.

NOTE

If fuel gauge deflects when circuit 28 or 29 wire is grounded, fuel sending unit is faulty.

- f. Observe fuel gauge for movement.

FUEL GAUGE INOPERATIVE - Continued**CONDITION/INDICATION**

IS FUEL LEVEL SENDING UNIT OPERATIONAL?

DECISION

YES - Go to Step (2).

NO - Replace fuel level sending unit (Volume 2, WP 0332). Go to Step (6) to verify problem is solved.

FUEL GAUGE INOPERATIVE - Continued**STEP**

2. ARE CIRCUIT WIRES 28 OR 29 FROM FUEL LEVEL SENDING UNIT TO FUEL SELECTOR SWITCH IN GOOD CONDITION?
 - a. Check for 5 to 8 VDC at fuel selector switch terminal.
 - b. Refer to point to point schematics.

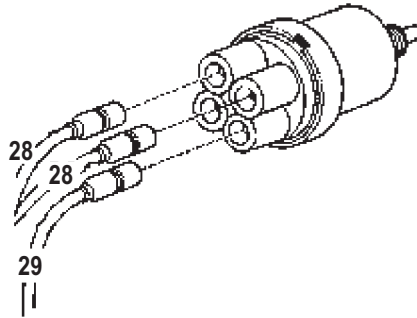

T0090DAA

Figure 2. Fuel Level Gauge Test.

- c. Place battery switch to the OFF position.

NOTE

Make sure fuel selector switch is set to side being tested.

- d. Disconnect circuit 28 or 29 wire from fuel selector switch (wire 28 for left hand tank, wire 29 for right hand tank).
- e. Place battery switch to ON position.
- f. Set multimeter to measure VDC.
- g. Connect multimeter red lead to open circuit 28 (pin B) or 29 (pin D) terminal at fuel selector switch.
- h. Connect multimeter black lead to vehicle chassis ground.

NOTE

If 5 to 8 VDC is present, circuit 28 or 29 wire is faulty.

- i. Meter reading should be between 5 and 8 VDC.

CONDITION/INDICATION

ARE CIRCUIT WIRES 28 OR 29 FROM FUEL LEVEL SENDING UNIT TO FUEL SELECTOR SWITCH IN GOOD CONDITION?

DECISION

YES - Go to Step (3).

NO - Repair or replace circuit 28 or 29 wire (Volume 3, WP 0352). Go to Step (6) to verify problem is solved.

FUEL GAUGE INOPERATIVE - Continued**STEP**

3. IS FUEL SELECTOR SWITCH IN GOOD OPERATING CONDITION?
 - a. Check for 5 to 8 VDC at circuit 28 wire pin A.
 - b. Refer to point to point schematics.

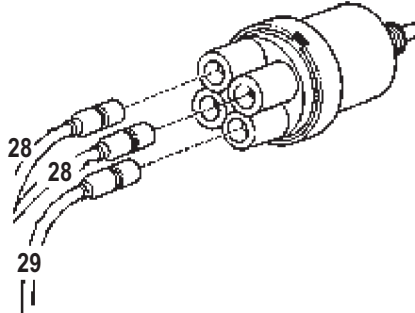

T0090DAA

Figure 3. Fuel Selector Switch.

- c. Place battery switch to the OFF position.
- d. Disconnect circuit 28 wire from fuel selector switch pin A.
- e. Place battery switch to ON position.
- f. Connect multimeter red lead to disconnected circuit 28 wire.
- g. Connect multimeter black lead to vehicle chassis ground.

NOTE

If 5 to 8 VDC is present, fuel selector switch is faulty.

- h. Meter reading should be between 5 and 8 VDC.

CONDITION/INDICATION

IS FUEL SELECTOR SWITCH IN GOOD OPERATING CONDITION?

DECISION

YES - Go to Step (4).

NO - Replace fuel selector switch (Volume 2, WP 0314). Go to Step (6) to verify problem is solved.

FUEL GAUGE INOPERATIVE - Continued**STEP**

4. IS THERE BATTERY VOLTAGE AT CIRCUIT 27 WIRE?
 - a. Check for battery voltage at circuit 27 wire.
 - b. Place battery switch to the OFF position.
 - c. Remove instrument cluster panel (Volume 2, WP 0310).
 - d. Refer to point to point schematics.

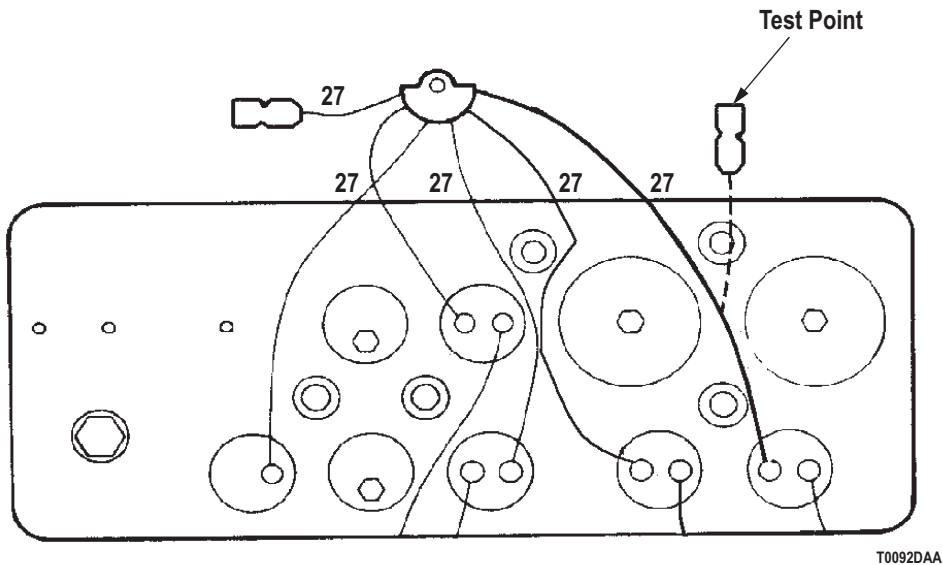

Figure 4. Fuel Gauge Test.

- e. Disconnect circuit 27 wire from inoperative fuel gauge.
- f. Place battery switch to ON position.
- g. Connect multimeter red lead to disconnected circuit 27 wire.
- h. Connect multimeter black lead to vehicle chassis ground.
- i. Meter reading should be greater than or equal to 18 VDC.

CONDITION/INDICATION

IS THERE BATTERY VOLTAGE AT CIRCUIT 27 WIRE?

DECISION

YES - Go to Step (5).

NO - Replace instrument cluster wiring harness (Volume 3, WP 0351). Go to Step (6) to verify problem is solved.

STEP

5. IS THERE VOLTAGE AT FUEL GAUGE?
 - a. Check for 5 to 8 VDC at fuel gauge.

FUEL GAUGE INOPERATIVE - Continued

- b. Place battery switch to the OFF position.
- c. Refer to point to point schematics.
- d. Reconnect circuit 27 wire to fuel gauge.

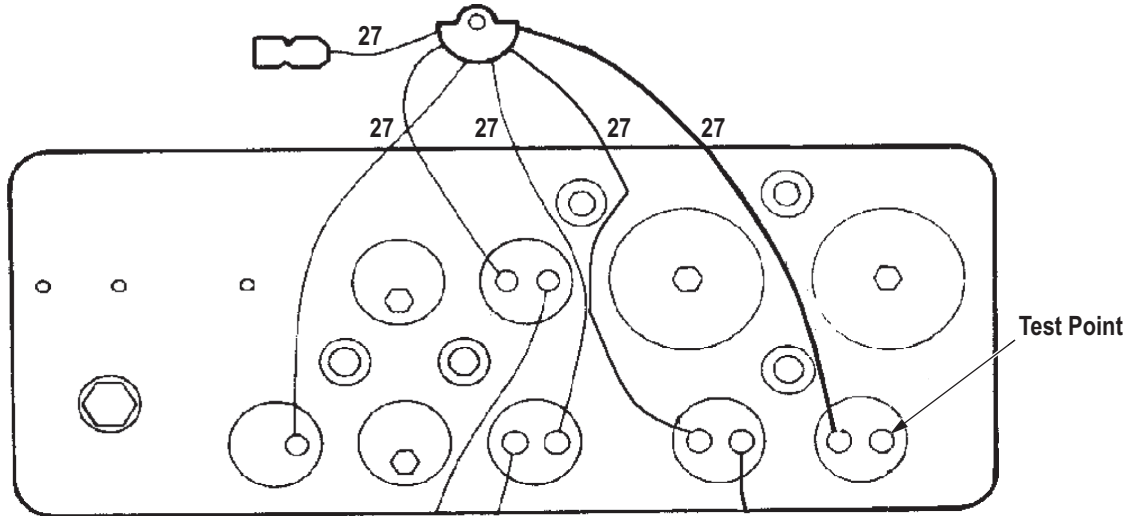

T0093DAA

Figure 5. Fuel Gauge Test.

NOTE

Trucks with right hand only tanks will disconnect circuit 29 wire from fuel gauge.

- e. Disconnect circuit 28 wire from fuel gauge.
- f. Place battery switch to ON position.
- g. Connect multimeter red lead to open terminal on fuel gauge.
- h. Connect multimeter black lead to vehicle chassis ground.

NOTE

If 5 to 8 VDC is not present at fuel gauge, fuel gauge is faulty.

- i. Meter reading should be between 5 and 8 VDC.

CONDITION/INDICATION

IS THERE VOLTAGE AT FUEL GAUGE?

DECISION

NO - Replace defective gauge (Volume 2, WP 0312). Go to Step (6) to verify problem is solved.

YES - Repair or replace circuit 28 wire from gauge to selector switch (Volume 3, WP 0352). Go to Step (6) to verify problem is solved.

FUEL GAUGE INOPERATIVE - Continued**STEP**

6. IS YOUR ORIGINAL PROBLEM STILL PRESENT?
 - a. Ensure vehicle is returned to normal operating condition.
 - b. Check to see if your original problem still exists.

CONDITION/INDICATION

IS YOUR ORIGINAL PROBLEM STILL PRESENT?

DECISION

YES - Notify supervisor.
NO - Problem fixed.

END OF WORK PACKAGE

**FIELD MAINTENANCE
BATTERY/ALTERNATOR GAUGE INOPERATIVE**

INITIAL SETUP:**Tools and Special Tools**

Tool Kit, General Mechanic's: Automotive
(Volume 5, WP 0826, Table 1, Item 56)
Multimeter
(Volume 5, WP 0826, Table 1, Item 34)
Test Set, Electronic Systems
(Volume 5, WP 0826, Table 1, Item 51)

References (cont.)

Volume 2, WP 0310
Volume 2, WP 0312
Volume 3, WP 0351

Equipment Condition

Vehicle parked and engine shut down.
(TM 9-2320-272-10)

Personnel Required

(2)

References

Point to Point Schematics

TROUBLESHOOTING PROCEDURE**BATTERY/ALTERNATOR GAUGE INOPERATIVE****NOTE**

Conduct these malfunction tests if battery-alternator gauge is inoperative. This procedure will check for faulty gauge or instrument cluster wiring harness.

BATTERY/ALTERNATOR GAUGE INOPERATIVE - Continued**STEP**

1. IS BATTERY-ALTERNATOR GAUGE PROPERLY GROUNDED?
 - a. Remove instrument cluster panel (Volume 2, WP 0310).

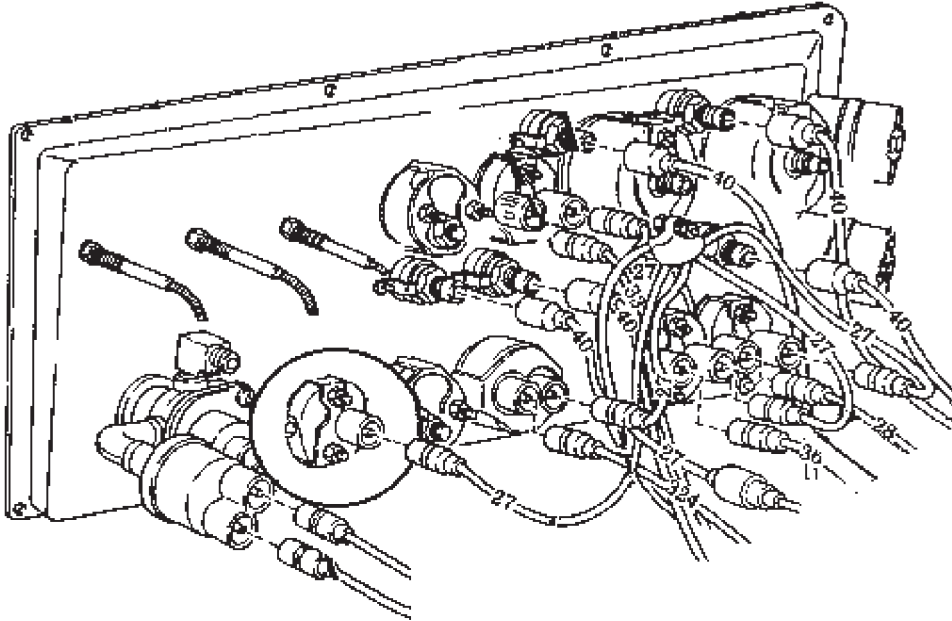

T0095DAA

Figure 1. Battery-Alternator Gauge.

- b. Visually inspect battery-alternator gauge for proper ground.
 - c. Clean and tighten indicator mounting point.

CONDITION/INDICATION

IS BATTERY-ALTERNATOR GAUGE PROPERLY GROUNDED?

DECISION

YES - Go to Step (2).

NO - Mounting points are damaged. Replace defective gauge (Volume 2, WP 0312). Go to Step (3) to verify problem is solved.

STEP

2. IS THERE BATTERY VOLTAGE AT CIRCUIT 27 WIRE?
 - a. Check for battery voltage at circuit 27 wire.
 - b. Place battery switch to the OFF position.
 - c. Refer to point to point schematics.

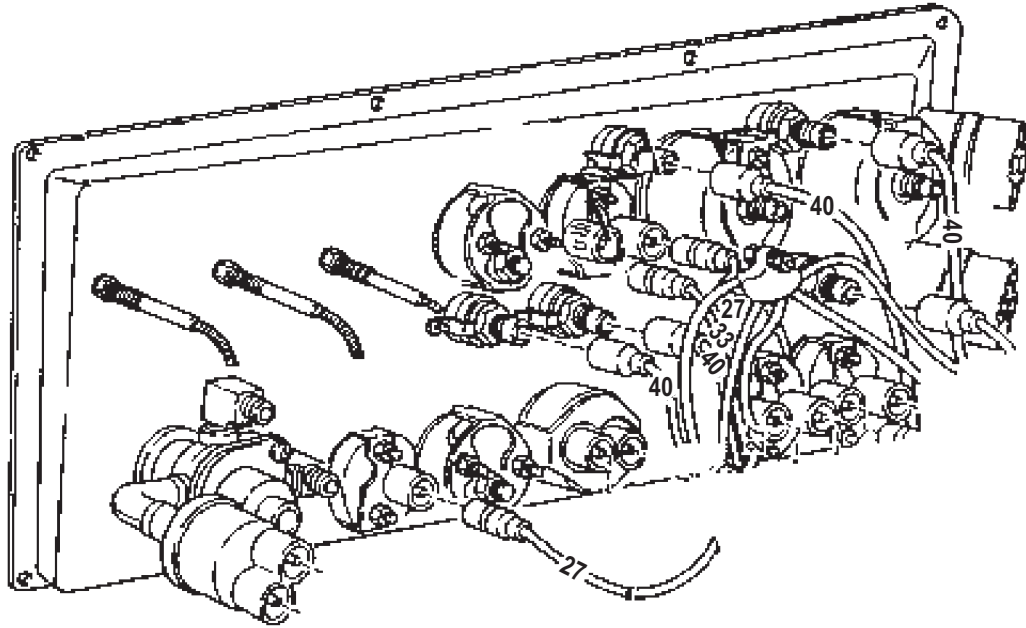
BATTERY/ALTERNATOR GAUGE INOPERATIVE - Continued

T0096DAA

Figure 2. Battery-Alternator Gauge Test.

- d. Disconnect circuit 27 wire from inoperative battery-alternator gauge.
- e. Place battery switch to ON position.
- f. Set multimeter to measure VDC.
- g. Connect multimeter red lead to disconnected circuit 27 wire.
- h. Connect multimeter black lead to vehicle chassis ground.
- i. Meter reading should be greater than or equal to 18 VDC.

CONDITION/INDICATION

IS THERE BATTERY VOLTAGE AT CIRCUIT 27 WIRE?

DECISION

YES - Replace defective gauge (Volume 2, WP 0312). Go to Step (3) to verify problem is solved.

NO - Replace instrument cluster wiring harness (Volume 3, WP 0351). Go to Step (3) to verify problem is solved.

BATTERY/ALTERNATOR GAUGE INOPERATIVE - Continued**STEP**

3. IS YOUR ORIGINAL PROBLEM STILL PRESENT?
 - a. Ensure vehicle is returned to normal operating condition.
 - b. Check to see if your original problem still exists.

CONDITION/INDICATION

IS YOUR ORIGINAL PROBLEM STILL PRESENT?

DECISION

YES - Notify supervisor.
NO - Problem fixed.

END OF WORK PACKAGE

**FIELD MAINTENANCE
HORN INOPERATIVE**

INITIAL SETUP:**Tools and Special Tools**

Tool Kit, General Mechanic's: Automotive
(Volume 5, WP 0826, Table 1, Item 56)
Multimeter
(Volume 5, WP 0826, Table 1, Item 34)
Test Set, Electronic Systems
(Volume 5, WP 0826, Table 1, Item 51)

References (cont.)

Volume 2, WP 0307
Volume 2, WP 0343
Volume 2, WP 0344
Volume 3, WP 0352
Volume 5, WP 0805

Personnel Required

(2)

Equipment Condition

Vehicle parked and engine shut down.
(TM 9-2320-272-10)

References

Point to Point Schematics

TROUBLESHOOTING PROCEDURE**HORN INOPERATIVE****NOTE**

Conduct these malfunction tests if horn is inoperative. This procedure will check for correct air and voltage supply, faulty wiring, horn solenoid and switch.

HORN INOPERATIVE - Continued**STEP**

1. DOES HORN ELECTRIC VALVE HAVE AIR SUPPLY?
 - a. Check air supply at air electric valve.

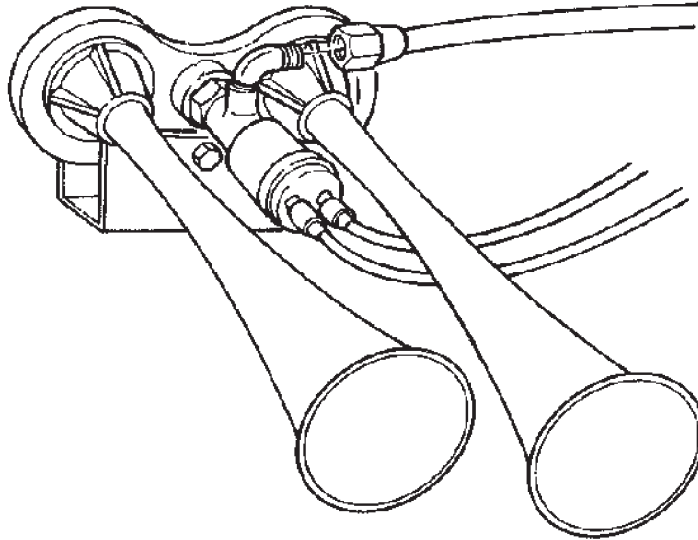

T0098DAA

Figure 1. Horn Air Supply.

- b. Make sure air gauges read normal operating pressure and warning buzzer is not sounding.
 - c. Loosen air supply line from horn air electric valve very slowly and listen for air escaping.

CONDITION/INDICATION

DOES HORN ELECTRIC VALVE HAVE AIR SUPPLY?

DECISION

YES - Go to Step (2).

NO - Replace damaged air supply line (Volume 5, WP 0805). Go to Step (7) to verify problem is solved.

STEP

2. DOES HORN CIRCUIT BREAKER HAVE PROPER INPUT VOLTAGE?
 - a. Measure voltage at horn circuit breaker wire 10.
 - b. Refer to point to point schematics.

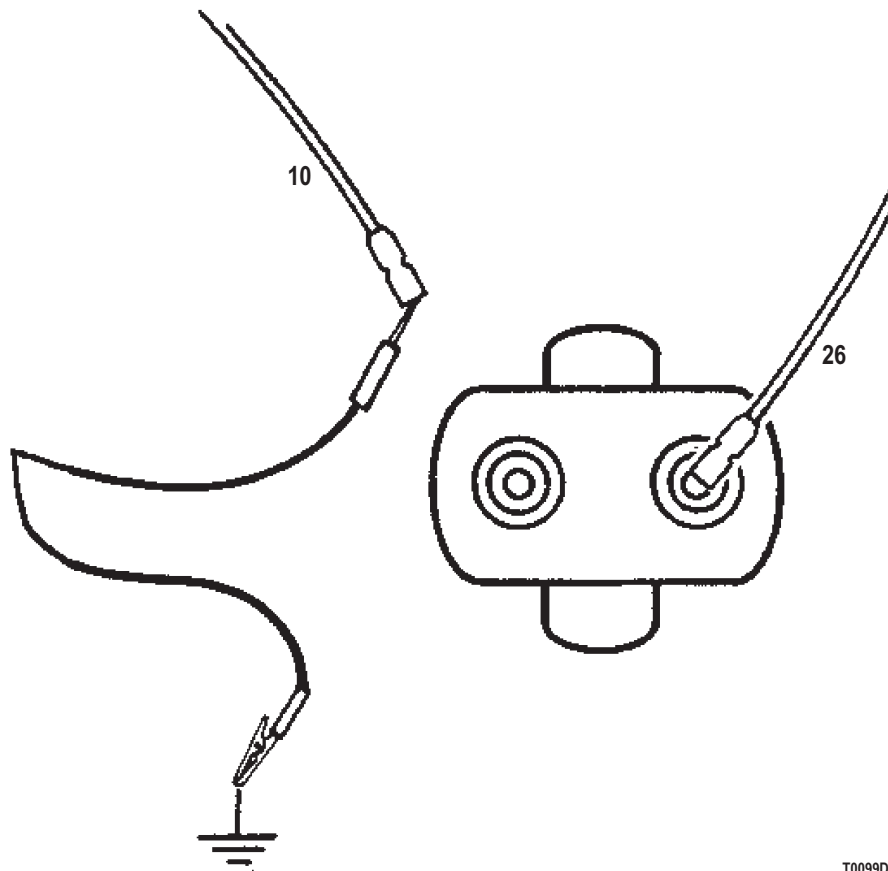
HORN INOPERATIVE - Continued

T0099DAA

Figure 2. Horn Circuit Breaker.

- c. Place battery switch to the OFF position.
- d. Disconnect circuit 10 wire from circuit breaker.
- e. Place battery switch to ON position.
- f. Set multimeter to measure VDC.
- g. Connect multimeter red lead to disconnected circuit 10 wire.
- h. Connect multimeter black lead to vehicle chassis ground.
- i. Meter reading should be greater than or equal to 18 VDC.

CONDITION/INDICATION

DOES HORN CIRCUIT BREAKER HAVE PROPER INPUT VOLTAGE?

DECISION

YES - Go to Step (3).

NO - Repair or replace circuit 10 wire (Volume 3, WP 0352). Go to Step (7) to verify problem is solved.

HORN INOPERATIVE - Continued**STEP**

3. DOES HORN CIRCUIT BREAKER HAVE PROPER OUTPUT VOLTAGE?
 - a. Check for battery voltage at horn circuit breaker terminal.
 - b. Place battery switch to the OFF position.

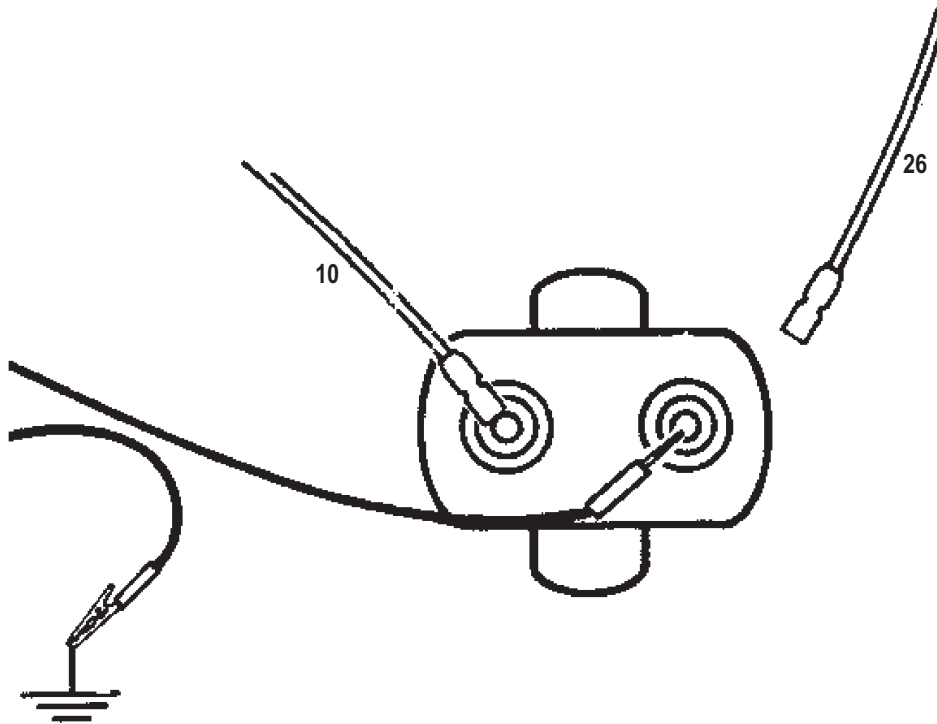

T0100DAA

Figure 3. Horn Circuit Breaker Test.

- c. Refer to point to point schematics.
- d. Reconnect circuit 10 wire and disconnect circuit 26 wire from circuit breaker.
- e. Place battery switch to ON position.
- f. Connect multimeter red lead to open circuit 26 terminal on circuit breaker.
- g. Connect multimeter black lead to vehicle chassis ground.
- h. Meter reading should be greater than or equal to 18 VDC.

CONDITION/INDICATION

DOES HORN CIRCUIT BREAKER HAVE PROPER OUTPUT VOLTAGE?

DECISION

YES - Go to Step (4).

NO - Replace circuit breaker (Volume 2, WP 0307). Go to Step (7) to verify problem is solved.

HORN INOPERATIVE - Continued**STEP**

4. DOES HORN SOLENOID HAVE BATTERY VOLTAGE?
 - a. Check for battery voltage at horn solenoid.
 - b. Place battery switch to the OFF position.
 - c. Refer to point to point schematics.

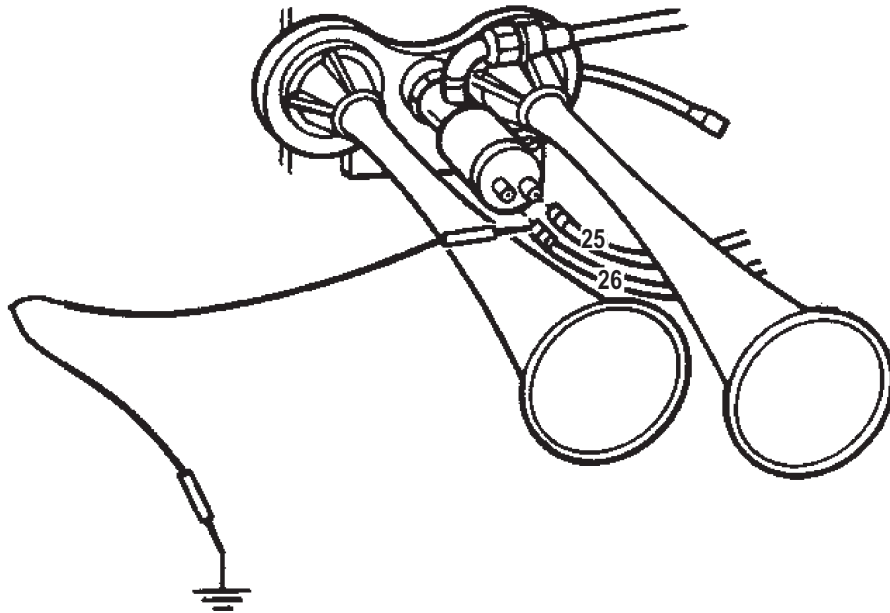

T0101DAA

Figure 4. Horn Solenoid Test.

- d. Reconnect circuit 26 wire to circuit breaker.
- e. Disconnect circuit 26 wire from horn solenoid.
- f. Place battery switch to ON position.
- g. Connect multimeter red lead to disconnected circuit 26 wire.
- h. Connect multimeter black lead to vehicle chassis ground.
- i. Meter reading should be greater than or equal to 18 VDC.

CONDITION/INDICATION

DOES HORN SOLENOID HAVE BATTERY VOLTAGE?

DECISION

YES - Go to Step (5).

NO - Repair or replace circuit 26 wire (Volume 3, WP 0352). Go to Step (7) to verify problem is solved.

HORN INOPERATIVE - Continued**STEP**

5. IS HORN SOLENOID OPERATING PROPERLY?
 - a. Check operation of horn solenoid.
 - b. Refer to point to point schematics.

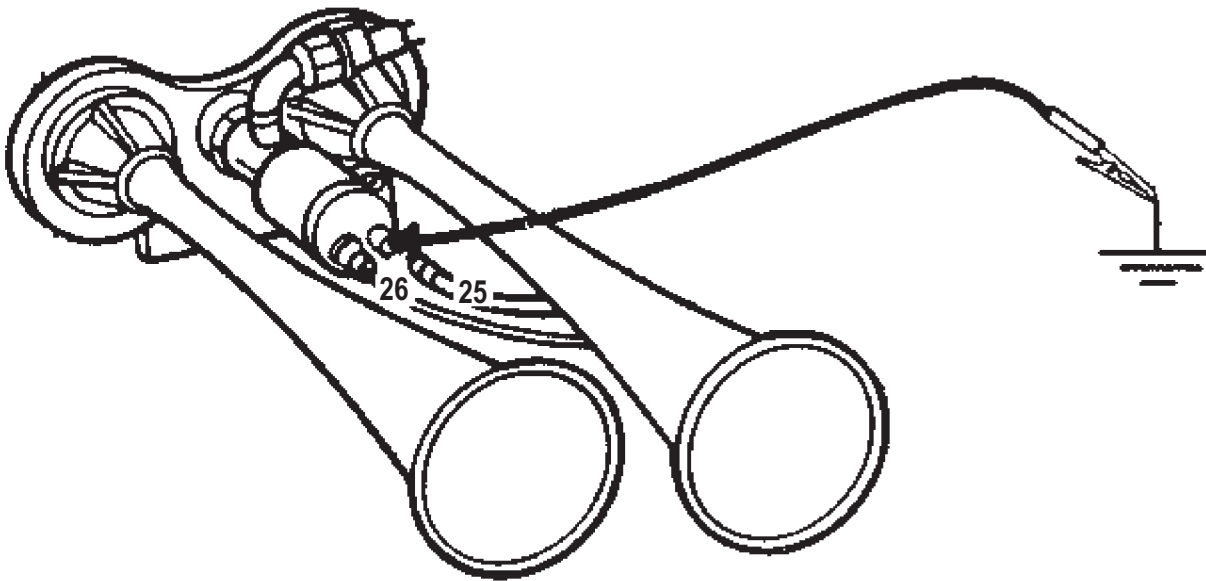

T0102DAA

Figure 5. Horn Solenoid Test.

HORN INOPERATIVE - Continued

- c. Reconnect circuit 26 wire to horn solenoid.
- d. Disconnect circuit 25 wire from horn solenoid.
- e. Connect one end of jumper wire to vehicle chassis ground.

NOTE

If horn does not operate, horn solenoid is faulty.

- f. Touch other end of jumper wire to circuit 25 wire connection point on horn solenoid.

CONDITION/INDICATION

IS HORN SOLENOID OPERATING PROPERLY?

DECISION

YES - Go to Step (6).

NO - Replace defective horn solenoid (Volume 2, WP 0343). Go to Step (7) to verify problem is solved.

HORN INOPERATIVE - Continued**STEP**

6. DOES HORN SWITCH WORK PROPERLY?
 - a. Check operation of horn switch.
 - b. Refer to point to point schematics.

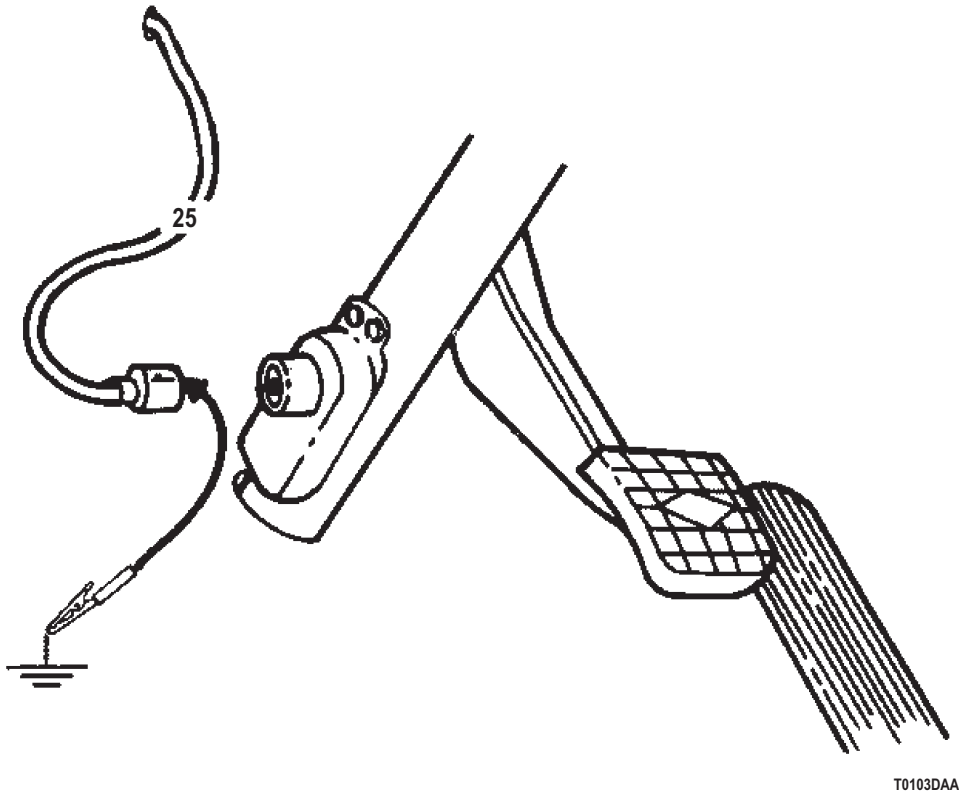

Figure 6. Horn Switch Test.

- c. Reconnect circuit 25 wire to horn solenoid.
- d. Disconnect circuit 25 wire from horn switch.
- e. Connect one end of jumper wire to vehicle chassis ground.

NOTE

If horn operates, horn switch is faulty.

- f. Touch other end of jumper wire to disconnected end of circuit 25 wire.

HORN INOPERATIVE - Continued**CONDITION/INDICATION**

DOES HORN SWITCH WORK PROPERLY?

DECISION

YES - Notify supervisor. Action may not be possible at this level of maintenance.

NO - Replace defective horn switch (Volume 2, WP 0344). Go to Step (7) to verify problem is solved.

STEP

7. IS YOUR ORIGINAL PROBLEM STILL PRESENT?
 - a. Ensure vehicle is returned to normal operating condition.
 - b. Check to see if your original problem still exists.

CONDITION/INDICATION

IS YOUR ORIGINAL PROBLEM STILL PRESENT?

DECISION

YES - Notify supervisor.

NO - Problem fixed.

END OF WORK PACKAGE

FIELD MAINTENANCE
LOW AIR PRESSURE WARNING BUZZER WILL NOT SHUT OFF (AIR PRESSURE GAUGES AT NORMAL SYSTEM PRESSURE)

INITIAL SETUP:**Tools and Special Tools**

Tool Kit, General Mechanic's: Automotive
(Volume 5, WP 0826, Table 1, Item 56)
Multimeter
(Volume 5, WP 0826, Table 1, Item 34)
Test Set, Electronic Systems
(Volume 5, WP 0826, Table 1, Item 51)

References (cont.)

Volume 2, WP 0336
Volume 2, WP 0342
Volume 3, WP 0352

Equipment Condition

Vehicle parked and engine shut down.
(TM 9-2320-272-10)

Personnel Required

(2)

References

Point to Point Schematics

TROUBLESHOOTING PROCEDURE**LOW AIR PRESSURE WARNING BUZZER WILL NOT SHUT OFF (AIR PRESSURE GAUGES AT NORMAL SYSTEM PRESSURE)****NOTE**

Conduct these malfunction tests if low air pressure warning buzzer will not shut off. This procedure will check for low air pressure, defective pressure switch or faulty wiring.

LOW AIR PRESSURE WARNING BUZZER WILL NOT SHUT OFF (AIR PRESSURE GAUGES AT NORMAL SYSTEM PRESSURE) - Continued**STEP**

1. IS PRIMARY LOW AIR PRESSURE SWITCH WORKING PROPERLY?
 - a. Check continuity for primary low air pressure switch.
 - b. Make sure air gauges read at least 90 psi.

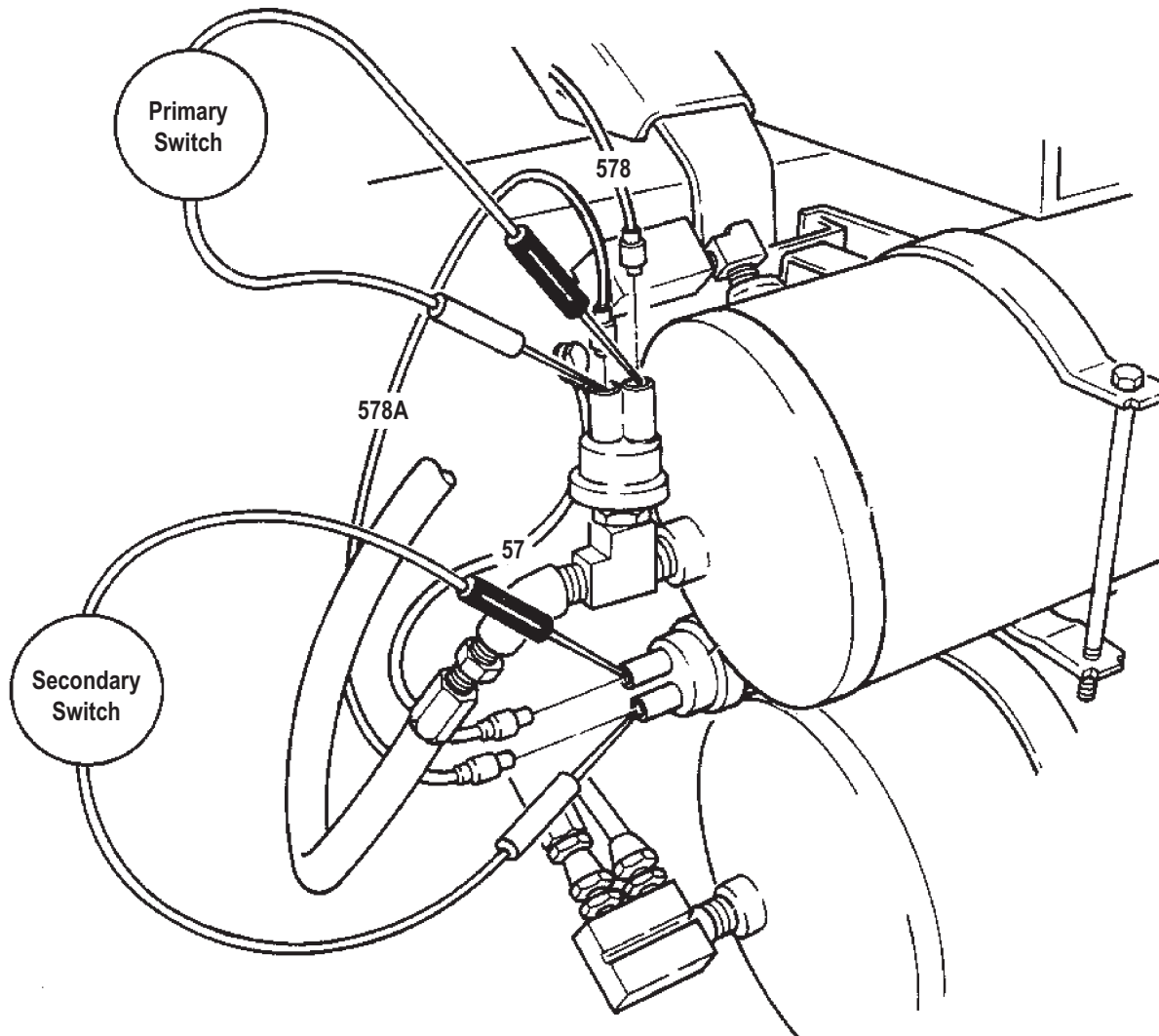

T0105DAA

Figure 1. Pressure Switch.

LOW AIR PRESSURE WARNING BUZZER WILL NOT SHUT OFF (AIR PRESSURE GAUGES AT NORMAL SYSTEM PRESSURE) - Continued

- c. Disconnect wires 578 and 578A from primary low air pressure switch.
- d. Set up multimeter to measure resistance.
- e. Connect multimeter red lead to contact end of pressure switch. Refer to point to point schematics.
- f. Connect multimeter black lead to other contact end of pressure switch.
- g. Meter reading should be less than 300 ohms.

CONDITION/INDICATION

IS PRIMARY LOW AIR PRESSURE SWITCH WORKING PROPERLY?

DECISION

NO - Replace primary low air pressure switch (Volume 2, WP 0342). Go to Step (6) to verify problem is solved.
YES - Go to Step (2).

LOW AIR PRESSURE WARNING BUZZER WILL NOT SHUT OFF (AIR PRESSURE GAUGES AT NORMAL SYSTEM PRESSURE) - Continued**STEP**

2. IS SECONDARY LOW AIR PRESSURE SWITCH WORKING PROPERLY?
 - a. Check continuity for secondary low air pressure switch.
 - b. Make sure air gauges read at least 90 psi.

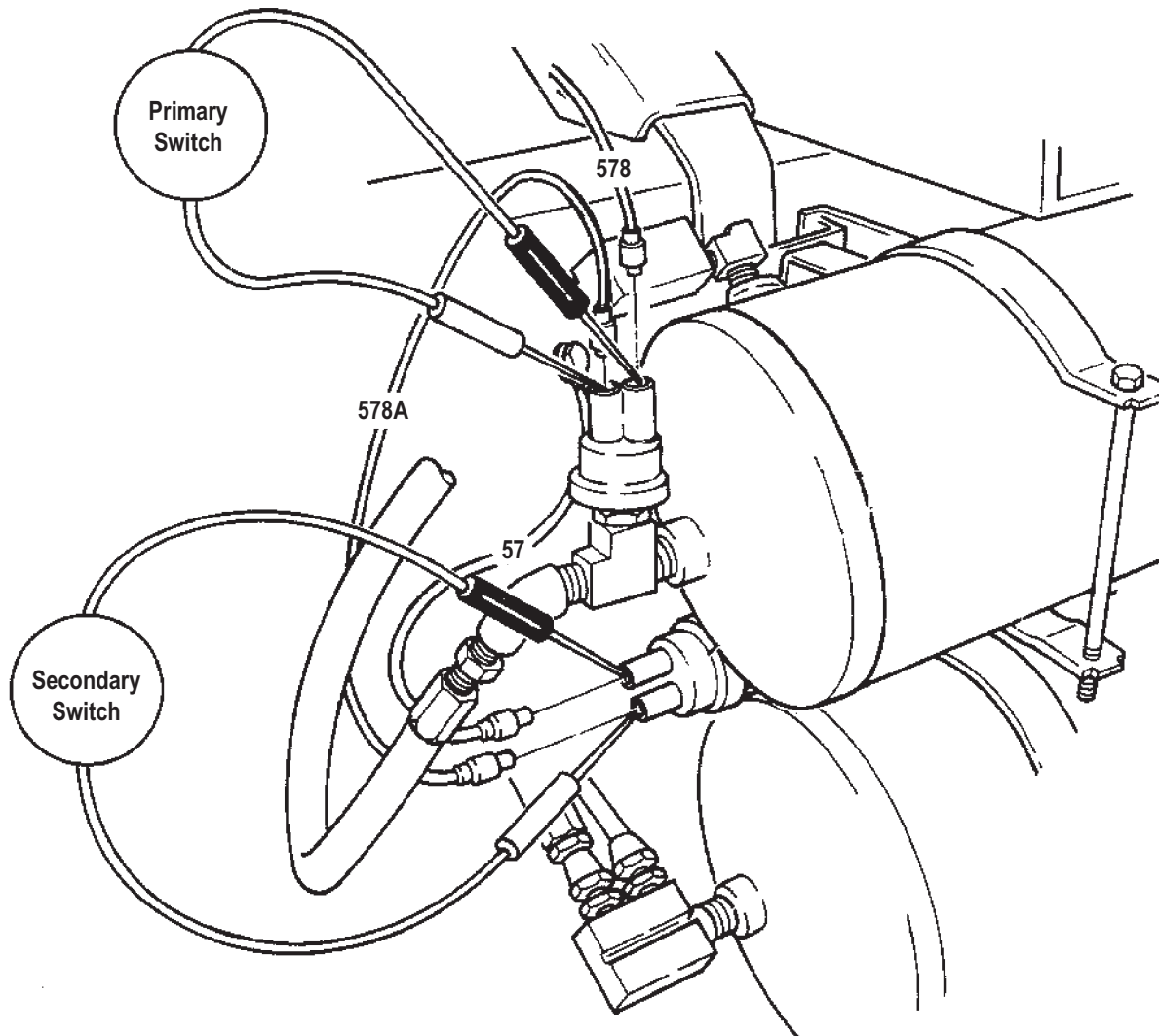

T0105DAA

Figure 2. Pressure Switch.

LOW AIR PRESSURE WARNING BUZZER WILL NOT SHUT OFF (AIR PRESSURE GAUGES AT NORMAL SYSTEM PRESSURE) - Continued

- c. Install wires 578 and 578A to primary low air pressure switch.
- d. Disconnect wires 57 and 578A from secondary low air pressure switch.
- e. Connect multimeter red lead to contact end of pressure switch. Refer to point to point schematics.
- f. Connect multimeter black lead to other contact end of pressure switch.
- g. Meter reading should be less than 300 ohms.

CONDITION/INDICATION

IS SECONDARY LOW AIR PRESSURE SWITCH WORKING PROPERLY?

DECISION

NO - Replace secondary low air pressure switch (Volume 2, WP 0342). Go to Step (6) to verify problem is solved.

YES - Go to Step (3).

LOW AIR PRESSURE WARNING BUZZER WILL NOT SHUT OFF (AIR PRESSURE GAUGES AT NORMAL SYSTEM PRESSURE) - Continued

STEP

3. IS WIRE 57 IN GOOD CONDITION?
 - a. Install wire 578A to secondary low air pressure switch.

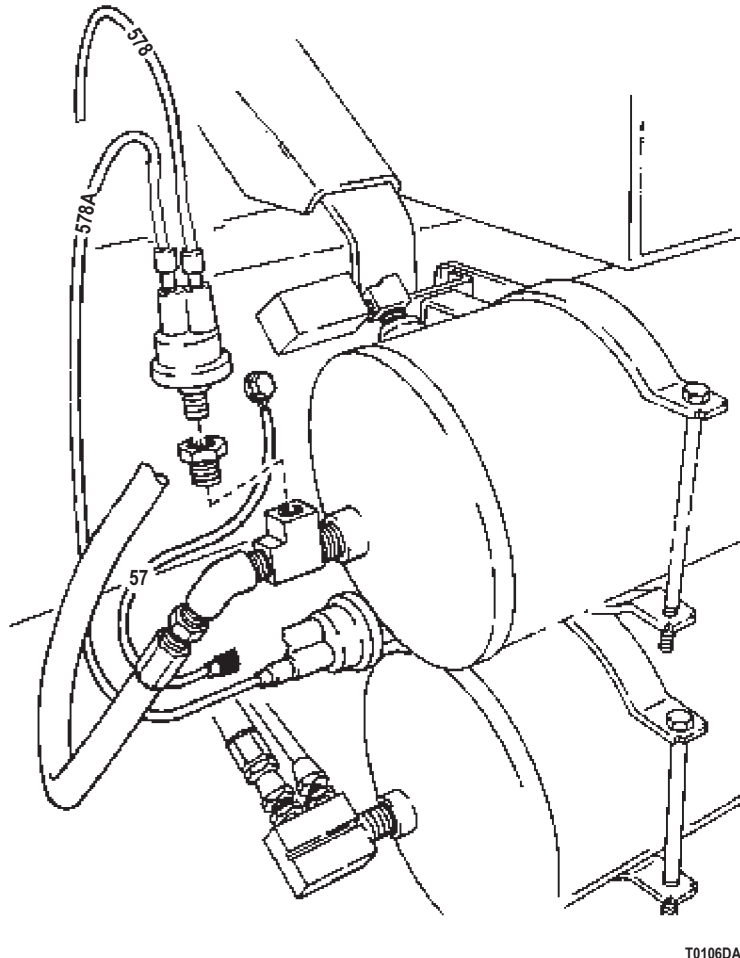

Figure 3. Pressure Switch Wire 57.

LOW AIR PRESSURE WARNING BUZZER WILL NOT SHUT OFF (AIR PRESSURE GAUGES AT NORMAL SYSTEM PRESSURE) - Continued

- b. Visually inspect wire 57 for frayed or damaged condition. Refer to point to point schematic.
- c. Disconnect wire 57 from secondary low air pressure switch.
- d. Place battery switch to ON position.
- e. Place start switch to RUN position.
- f. Make sure air gauges read at least 90 psi.

NOTE

If alarm is silenced when jumper wire is installed, wire 57 is faulty.

- g. Connect jumper wire from open contact on secondary low air pressure switch to good ground.

CONDITION/INDICATION

IS WIRE 57 IN GOOD CONDITION?

DECISION

NO - Repair or replace wire 57 (Volume 3, WP 0352). Go to Step (6) to verify problem is solved.

YES - Go to Step (4).

LOW AIR PRESSURE WARNING BUZZER WILL NOT SHUT OFF (AIR PRESSURE GAUGES AT NORMAL SYSTEM PRESSURE) - Continued**STEP**

4. IS WIRE 578A IN GOOD CONDITION?
 - a. Place battery switch to OFF position.
 - b. Install wire 57 to secondary low air pressure switch.

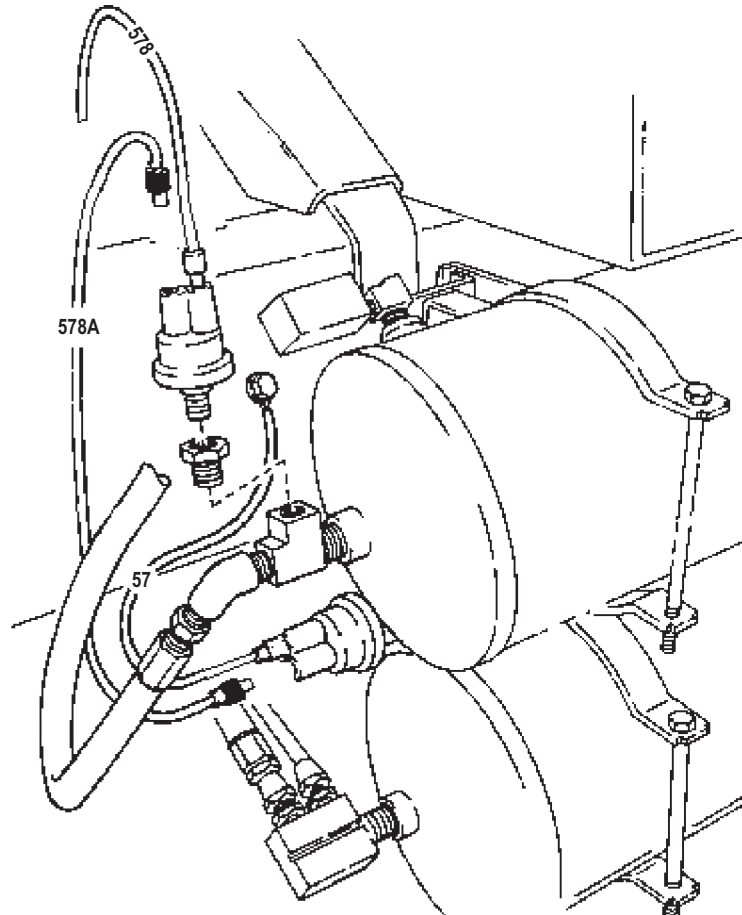

T0107DAA

Figure 4. Pressure Switch Wire 578A.

LOW AIR PRESSURE WARNING BUZZER WILL NOT SHUT OFF (AIR PRESSURE GAUGES AT NORMAL SYSTEM PRESSURE) - Continued

- c. Visually inspect wire 578A for frayed or damaged condition. Refer to point to point schematic.
- d. Disconnect wire 578A from primary and secondary low air pressure switch.
- e. Place battery switch to ON position.
- f. Place start switch to RUN position.
- g. Make sure air gauges read at least 90 psi.

NOTE

If alarm is silenced when jumper wire is installed, wire 578A is faulty.

- h. Connect jumper wire from open contact on primary low air pressure switch to open contact on secondary low air pressure switch.

CONDITION/INDICATION

IS WIRE 578A IN GOOD CONDITION?

DECISION

NO - Repair or replace wire 578A (Volume 3, WP 0352). Go to Step (6) to verify problem is solved.
NO - Go to Step (5).

LOW AIR PRESSURE WARNING BUZZER WILL NOT SHUT OFF (AIR PRESSURE GAUGES AT NORMAL SYSTEM PRESSURE) - Continued

STEP

5. IS WIRE 578 IN GOOD CONDITION?

- a. Place battery switch to OFF position.
- b. Install wire 578A to primary and secondary low air pressure switch.

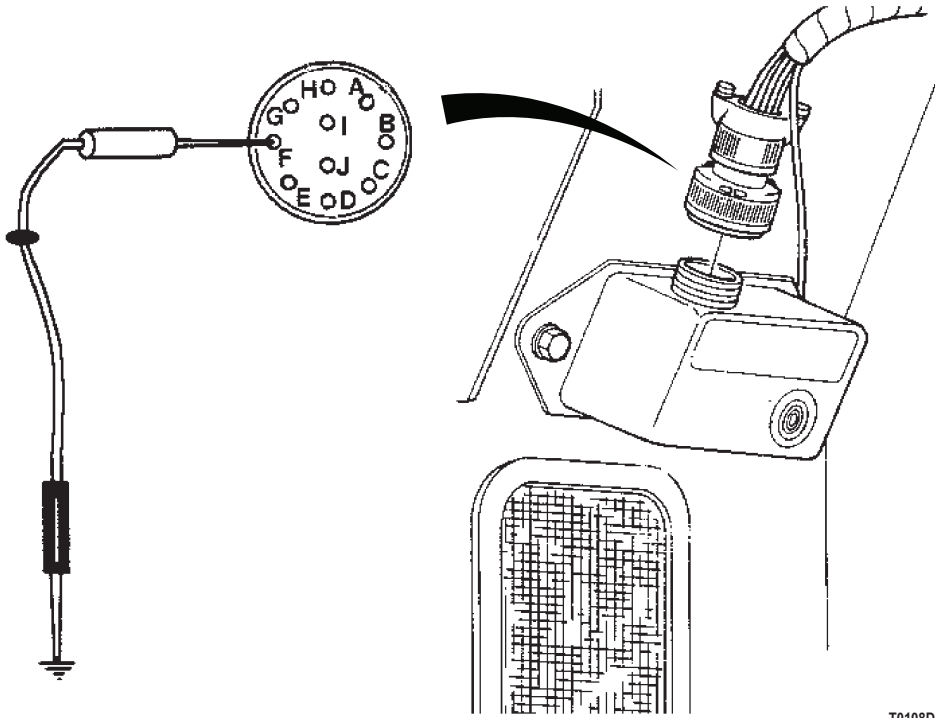

T0108DAA

Figure 5. Failsafe Warning Control Module.

- c. Visually inspect wire 578 for frayed or damaged condition.
- d. Disconnect wiring harness at failsafe warning control module.
- e. Make sure air gauges read at least 90 psi.
- f. Connect multimeter red lead to pin F on wiring harness connector. Refer to point to point schematics.
- g. Connect multimeter black lead to good ground.
- h. Meter reading should be less than 600 ohms.

LOW AIR PRESSURE WARNING BUZZER WILL NOT SHUT OFF (AIR PRESSURE GAUGES AT NORMAL SYSTEM PRESSURE) - Continued**CONDITION/INDICATION**

IS WIRE 578 IN GOOD CONDITION?

DECISION

NO - Repair or replace wire 578 (Volume 3, WP 0352). Go to Step (6) to verify problem is solved.

YES - Replace failsafe warning control module (Volume 2, WP 0336). Go to Step (6) to verify problem is solved.

STEP

6. IS YOUR ORIGINAL WARNING BUZZER PROBLEM STILL PRESENT?
 - a. Ensure vehicle is returned to normal operating condition.
 - b. Check to see if your original warning buzzer problem still exists.

CONDITION/INDICATION

IS YOUR ORIGINAL WARNING BUZZER PROBLEM STILL PRESENT?

DECISION

YES - Notify supervisor.

NO - Problem fixed.

END OF WORK PACKAGE

FIELD MAINTENANCE**LOW AIR PRESSURE WARNING BUZZER WILL NOT SHUT OFF AND PARKING BRAKE WARNING LIGHT FLASHES WITH HAND/PARKING BRAKE IN ANY POSITION (AIR PRESSURE NORMAL)**

INITIAL SETUP:**Tools and Special Tools**

Tool Kit, General Mechanic's: Automotive
(Volume 5, WP 0826, Table 1, Item 56)
Multimeter
(Volume 5, WP 0826, Table 1, Item 34)
Test Set, Electronic Systems
(Volume 5, WP 0826, Table 1, Item 51)

References (cont.)

Volume 2, WP 0336
Volume 3, WP 0431

Equipment Condition

Vehicle parked and engine shut down.
(TM 9-2320-272-10)

Personnel Required

(2)

References

Point to Point Schematics

TROUBLESHOOTING PROCEDURE**LOW AIR PRESSURE WARNING BUZZER WILL NOT SHUT OFF AND PARKING BRAKE WARNING LIGHT FLASHES WITH HAND/PARKING BRAKE IN ANY POSITION (AIR PRESSURE NORMAL)****NOTE**

Conduct these malfunction tests if low air pressure warning buzzer will not shut off and parking brake warning light flashes with hand/parking brake in any position. This procedure will check for low air pressure, defective pressure switch or faulty wiring.

LOW AIR PRESSURE WARNING BUZZER WILL NOT SHUT OFF AND PARKING BRAKE WARNING LIGHT FLASHES WITH HAND/PARKING BRAKE IN ANY POSITION (AIR PRESSURE NORMAL) - Continued

STEP

1. IS PARKING BRAKE PRESSURE SWITCH WORKING PROPERLY?
 - a. Check continuity for parking brake pressure switch.
 - b. Release parking brake.

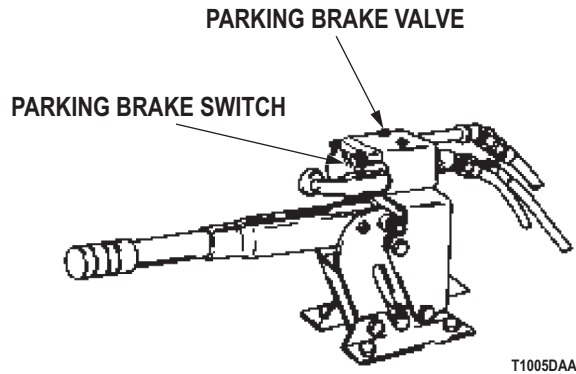

Figure 1. Pressure Switch.

- c. Disconnect wires 584 from parking brake pressure switch (under cab).
- d. Set up multimeter to measure resistance.
- e. Connect multimeter red lead to contact end of pressure switch. Refer to point to point schematics.
- f. Connect multimeter black lead to good ground.
- g. Meter reading should be less than 200 ohms.

CONDITION/INDICATION

IS PARKING BRAKE SWITCH WORKING PROPERLY?

DECISION

NO - Replace parking brake switch (Volume 3, WP 0431). Go to Step (3) to verify problem is solved.
 YES - Go to Step (2).

STEP

2. IS WIRE 584 IN GOOD CONDITION?
 - a. Install wire 584 to parking brake pressure switch.

LOW AIR PRESSURE WARNING BUZZER WILL NOT SHUT OFF AND PARKING BRAKE WARNING LIGHT FLASHES WITH HAND/PARKING BRAKE IN ANY POSITION (AIR PRESSURE NORMAL) - Continued

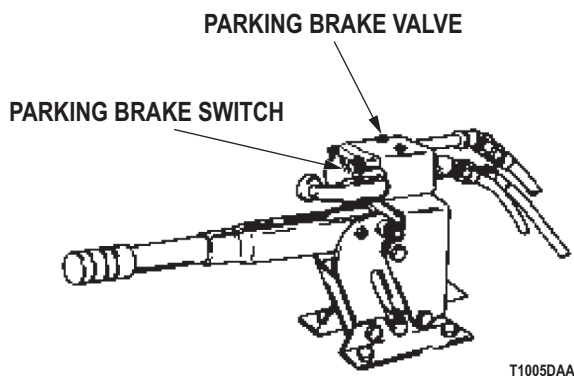

Figure 2. Pressure Switch.

- b. Visually inspect wire 584 for frayed or damaged condition.
- c. Disconnect wiring harness at failsafe warning control module.
- d. Make sure parking brakes are released.
- e. Connect multimeter red lead to pin I on wiring harness connector. Refer to point to point schematics.
- f. Connect multimeter black lead to good ground.
- g. Meter reading should be less than 200 ohms.

CONDITION/INDICATION

IS WIRE 584 IN GOOD CONDITION?

DECISION

NO - Replace failsafe module (Volume 2, WP 0336). Go to Step (3) to verify problem is solved.
 YES - Notify supervisor. Action may not be possible at this level of maintenance.

STEP

3. IS YOUR ORIGINAL WARNING BUZZER PROBLEM STILL PRESENT?
 - a. Ensure vehicle is returned to normal operating condition.
 - b. Check to see if your original warning buzzer problem still exists.

CONDITION/INDICATION

IS YOUR ORIGINAL WARNING BUZZER PROBLEM STILL PRESENT?

DECISION

YES - Notify supervisor.
 NO - Problem fixed.

END OF WORK PACKAGE

FIELD MAINTENANCE
SPRING BRAKE WARNING LIGHT INOPERATIVE WITH SPRING BRAKE OVERRIDE ENGAGED

INITIAL SETUP:**Tools and Special Tools**

Tool Kit, General Mechanic's: Automotive
(Volume 5, WP 0826, Table 1, Item 56)
Multimeter
(Volume 5, WP 0826, Table 1, Item 34)
Test Set, Electronic Systems
(Volume 5, WP 0826, Table 1, Item 51)

References (cont.)

Volume 2, WP 0307
Volume 2, WP 0308
Volume 2, WP 0310
Volume 2, WP 0311
Volume 3, WP 0352

Personnel Required

(2)

Equipment Condition

Vehicle parked and engine shut down.
(TM 9-2320-272-10)

References

Point to Point Schematics

TROUBLESHOOTING PROCEDURE**SPRING BRAKE WARNING LIGHT INOPERATIVE WITH SPRING BRAKE OVERRIDE ENGAGED****NOTE**

Conduct these malfunction tests if spring brake warning light is inoperative with spring brake override engaged. This procedure will check for bad lamp, faulty spring brake pressure switch or faulty circuit breaker.

SPRING BRAKE WARNING LIGHT INOPERATIVE WITH SPRING BRAKE OVERRIDE ENGAGED - Continued**STEP**

1. IS SPRING BRAKE OVERRIDE WARNING LIGHT LAMP IN GOOD CONDITION?
 - a. Visually inspect lamp and lamp holder for faulty condition.

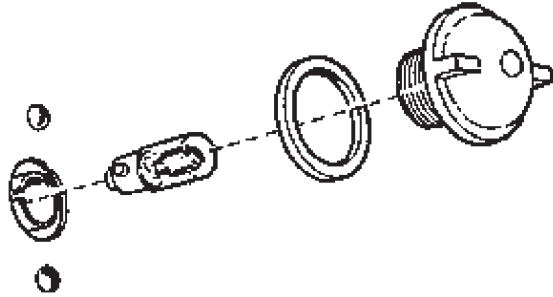

T0110DAA

Figure 1. Spring Brake Override Light.

- b. Check lamp holder for corrosion and damage.
- c. Replace lamp with one known to be operational (Volume 2, WP 0311).

NOTE

If spring brake override lamp operates, bulb was faulty.

- d. Check if spring brake override lamp operates.

CONDITION/INDICATION

IS SPRING BRAKE OVERRIDE WARNING LIGHT LAMP IN GOOD CONDITION?

DECISION

NO - Go to Step (5) to verify problem is solved.
 YES - Go to Step (2).

STEP

2. DOES SPRING BRAKE PRESSURE SWITCH OPERATE PROPERLY?
 - a. Remove instrument cluster to access spring brake pressure switch (Volume 2, WP 0310).
 - b. Disconnect both circuit 37 wires.

SPRING BRAKE WARNING LIGHT INOPERATIVE WITH SPRING BRAKE OVERRIDE ENGAGED - Continued

Figure 2. Spring Brake Pressure Switch Wire 37.

- c. Connect a jumper wire from one circuit 37 wire to another. Refer to point to point schematic.
- d. Place battery switch to ON position.

NOTE

If spring brake override lamp operates, spring brake pressure switch is faulty.

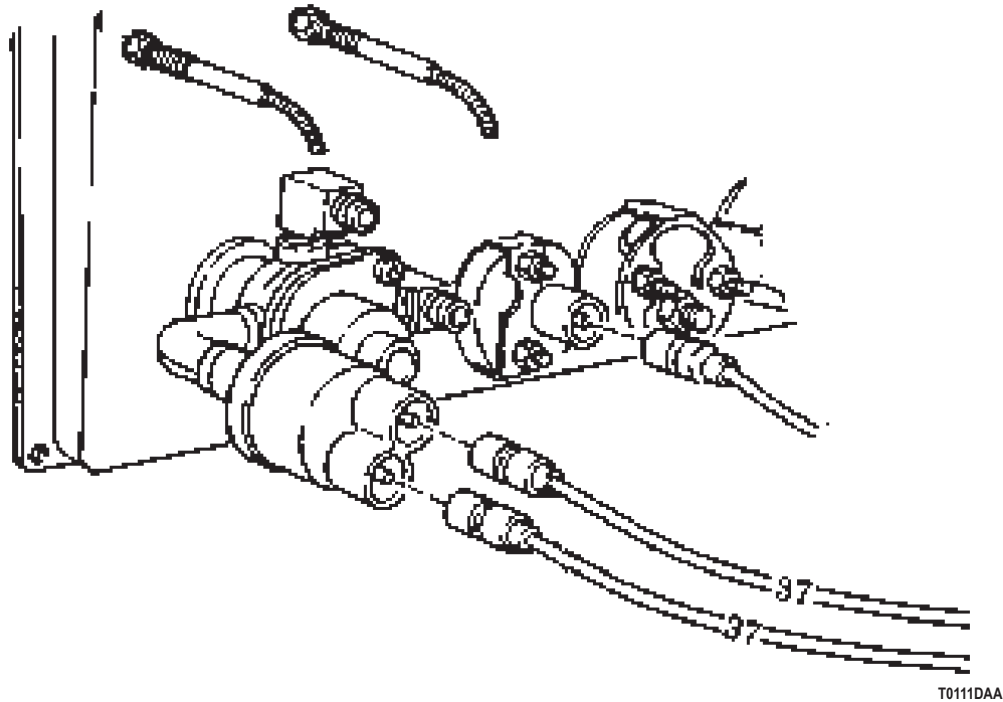
- e. Check if spring brake override lamp operates.

CONDITION/INDICATION

DOES SPRING BRAKE PRESSURE SWITCH OPERATE PROPERLY?

DECISION

NO - Replace defective spring brake pressure switch (Volume 2, WP 0308). Go to Step (5) to verify problem is solved.

YES - Go to Step (3).

SPRING BRAKE WARNING LIGHT INOPERATIVE WITH SPRING BRAKE OVERRIDE ENGAGED - Continued**STEP**

3. IS THERE BATTERY VOLTAGE AT SPRING BRAKE WARNING LIGHT CIRCUIT BREAKER?
 - a. Place battery switch to OFF position.
 - b. Disconnect circuit 10 wire at circuit breaker.

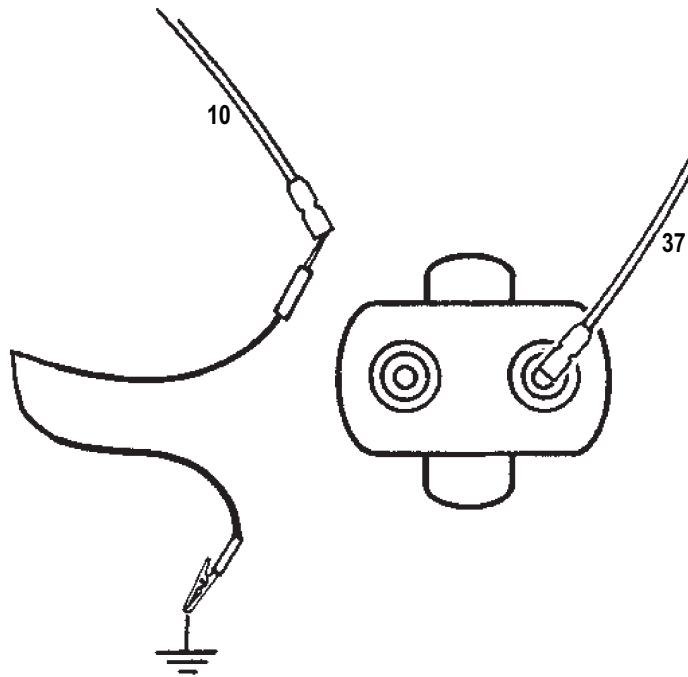

T0112DAA

Figure 3. Spring Brake Override Warning Circuit Breaker Wire 10.

- c. Place battery switch to ON position.
- d. Set up multimeter to measure VDC.
- e. Connect multimeter red lead to circuit 10 wire as shown. Refer to point to point schematics.
- f. Connect multimeter black lead to vehicle chassis ground.
- g. Meter reading should be greater than 18 VDC.

CONDITION/INDICATION

IS THERE BATTERY VOLTAGE AT SPRING BRAKE WARNING LIGHT CIRCUIT BREAKER?

DECISION

NO - Notify supervisor. Action may not be possible at this level of maintenance.
 YES - Go to Step (4).

STEP

4. IS THERE BATTERY VOLTAGE AT CIRCUIT 37 TERMINAL OF CIRCUIT BREAKER?
 - a. Place battery switch to OFF position.

SPRING BRAKE WARNING LIGHT INOPERATIVE WITH SPRING BRAKE OVERRIDE ENGAGED - Continued

- b. Reconnect circuit 10 wire.

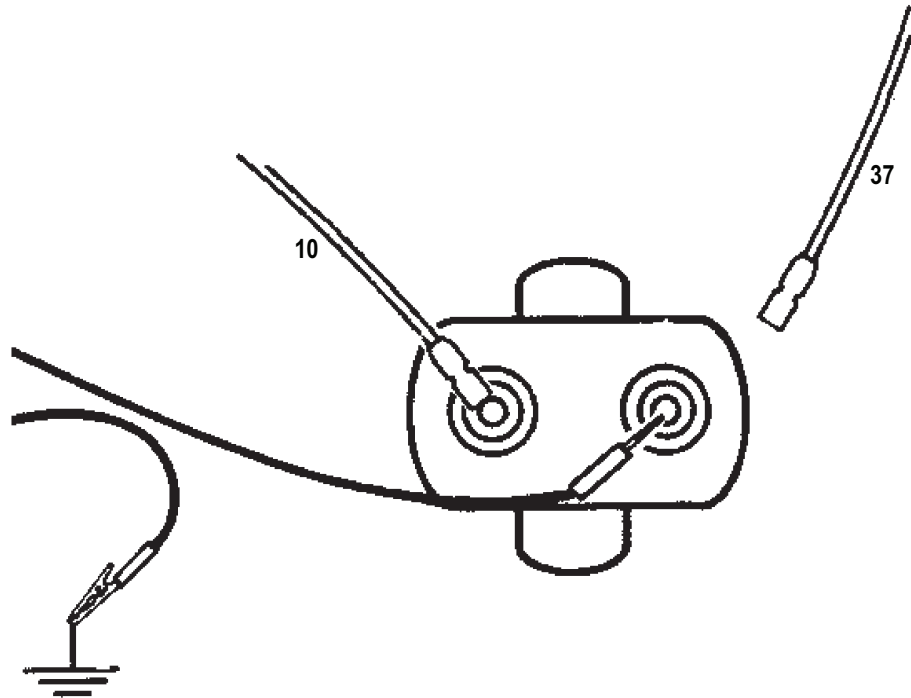

T0113DAA

Figure 4. Spring Brake Override Warning Circuit Breaker Wire 37.

- c. Disconnect circuit 37 wire from circuit breaker.
 d. Place battery switch to ON position.
 e. Connect multimeter red lead to circuit 37 terminal at circuit breaker as shown. Refer to point to point schematics.
 f. Connect multimeter black lead to vehicle chassis ground.
 g. Meter reading should be greater than 18 VDC.

CONDITION/INDICATION

IS THERE BATTERY VOLTAGE AT CIRCUIT 37 TERMINAL OF CIRCUIT BREAKER?

DECISION

NO - Replace defective circuit breaker (Volume 2, WP 0307). Go to Step (5) to verify problem is solved.
 YES - Repair or replace circuit 37 wire from circuit breaker to brake pressure switch (Volume 3, WP 0352). Go to Step (5) to verify problem is solved.

SPRING BRAKE WARNING LIGHT INOPERATIVE WITH SPRING BRAKE OVERRIDE ENGAGED - Continued**STEP**

5. IS YOUR ORIGINAL WARNING LIGHT PROBLEM STILL PRESENT?
 - a. Ensure vehicle is returned to normal operating condition.
 - b. Check to see if your original warning light problem still exists.

CONDITION/INDICATION

IS YOUR ORIGINAL WARNING LIGHT PROBLEM STILL PRESENT?

DECISION

YES - Notify supervisor.
NO - Problem fixed.

END OF WORK PACKAGE

**FIELD MAINTENANCE
ONE OR MORE TRAILER LIGHTS INOPERATIVE**

INITIAL SETUP:**Tools and Special Tools**

Tool Kit, General Mechanic's: Automotive
(Volume 5, WP 0826, Table 1, Item 56)
Multimeter
(Volume 5, WP 0826, Table 1, Item 34)
Test Set, Electronic Systems
(Volume 5, WP 0826, Table 1, Item 51)

References (cont.)

WP 0094
WP 0095
WP 0096
Volume 3, WP 0352

Personnel Required

(2)

Equipment Condition

Vehicle parked and engine shut down.
(TM 9-2320-272-10)

References

Point to Point Schematics

TROUBLESHOOTING PROCEDURE**ONE OR MORE TRAILER LIGHTS INOPERATIVE****NOTE**

Conduct these malfunction tests if one or more trailer lights are inoperative. This procedure will check for battery voltage at trailer receptacle, faulty wires or connections at trailer receptacle and faulty lamps.

ONE OR MORE TRAILER LIGHTS INOPERATIVE - Continued

STEP

1. DOES CORRESPONDING LIGHTING SYSTEM ON TRUCK FUNCTION?
 - a. Place battery switch to ON position.

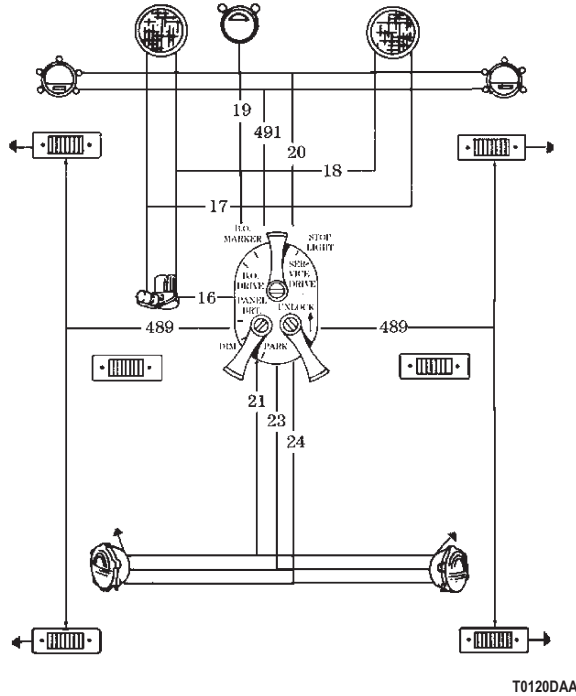

Figure 1. Lighting System.

- b. Place truck main light switch in position corresponding to inoperative system on trailer.

NOTE

For stoplight circuit test, air pressure must be maintained at operating pressure and brake pedal must be depressed.

- c. Check if corresponding lighting system on truck operates.

CONDITION/INDICATION

DOES CORRESPONDING LIGHTING SYSTEM ON TRUCK FUNCTION?

DECISION

- NO - Blackout marker lights do not operate. Perform Blackout Drive Or Marker Light Inoperative troubleshooting (WP 0094).
- NO - Service or blackout stoplights do not operate. Perform Stoplights Inoperative (Service or Blackout) troubleshooting (WP 0095).
- NO - Tail and marker lights do not operate. Perform Tail and Marker Lights Inoperative troubleshooting (WP 0096).
- YES - Go to Step (2).

ONE OR MORE TRAILER LIGHTS INOPERATIVE - Continued

STEP

2. IS THERE BATTERY VOLTAGE AT TRAILER RECEPTACLE?

- a. Place battery switch to ON position.
- b. Place truck main light switch in position corresponding to inoperative system on trailer.
- c. Set up multimeter to measure VDC.

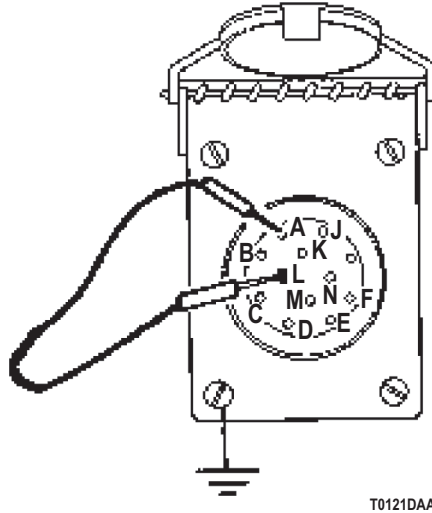

Figure 2. Trailer Receptacle.

- d. Connect multimeter red lead to the trailer receptacle socket terminal pin that corresponds to circuit being tested. Refer to point to point schematics.
- e. Connect multimeter black lead to trailer receptacle socket terminal pin L.

NOTE

For stoplight circuit test, air pressure must be maintained at operating pressure and brake pedal must be depressed.

- f. Meter reading should be greater than 18 VDC for each reading. Note reading.

CONDITION/INDICATION

IS THERE BATTERY VOLTAGE AT TRAILER RECEPTACLE?

DECISION

- NO - Go to Step (3).
- YES - Go to Step (5).

ONE OR MORE TRAILER LIGHTS INOPERATIVE - Continued**STEP**

3. IS TRAILER RECEPTACLE PROPERLY GROUNDED?
 - a. Place battery switch to OFF position.

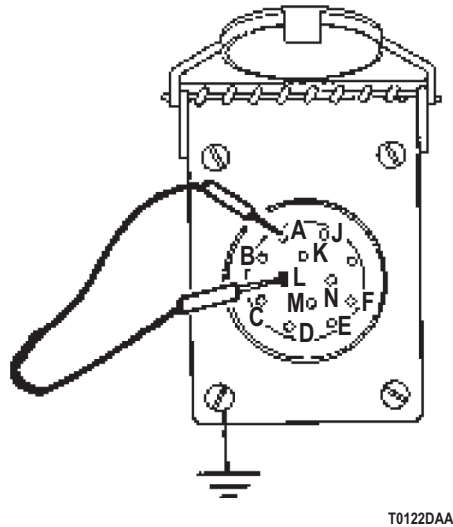

Figure 3. Trailer Receptacle.

- b. Set up multimeter to measure resistance.
- c. Connect multimeter red lead to circuit 90 wire at socket (receptacle terminal L and then D). Refer to point to point schematics.
- d. Connect multimeter black lead to good ground.
- e. Meter reading should be less than 200 ohms for both measurements.

CONDITION/INDICATION

IS TRAILER RECEPTACLE PROPERLY GROUNDED?

DECISION

NO - Repair broken circuit 90 wire (Volume 3, WP 0352). Go to Step (7) to verify problem is solved.
 YES - Go to Step (4).

ONE OR MORE TRAILER LIGHTS INOPERATIVE - Continued**STEP**

4. IS WIRING HARNESS IN GOOD CONDITION?

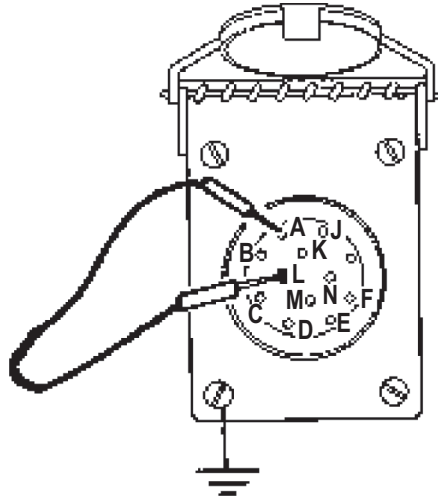

T0122DAA

Figure 4. Trailer Receptacle.

Visually check wiring harness for loose connections or broken wiring. Refer to point to point schematic.

CONDITION/INDICATION

IS WIRING HARNESS IN GOOD CONDITION?

DECISION

NO - Repair or replace broken wire (Volume 3, WP 0352). Go to Step (7) to verify problem is solved.
YES - Notify supervisor. Action may not be possible at this level of maintenance.

ONE OR MORE TRAILER LIGHTS INOPERATIVE - Continued**STEP**

5. IS TRAILER LIGHTING SYSTEM CABLE IN GOOD CONDITION?
 - a. Check trailer lighting system cable for continuity and for broken or frayed condition.
 - b. Disconnect both ends of the trailer lighting system cable.

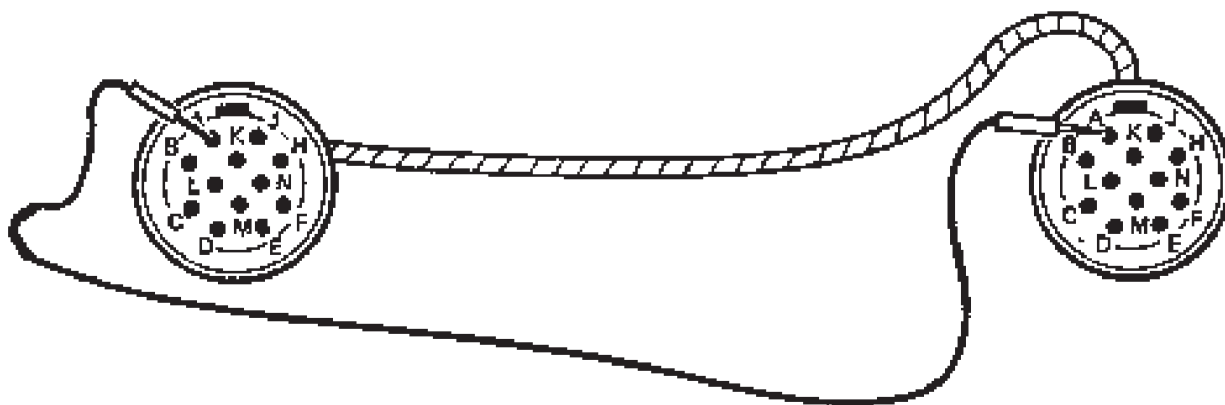

T0123DAA

Figure 5. Trailer Lighting System Cable.

- c. Open and lock hinged covers on trailer lighting system cable.
- d. Set up multimeter to measure resistance.
- e. Connect multimeter red lead to socket on one end of the cable.
- f. Connect multimeter red lead to corresponding socket on other end of the cable.
- g. Meter reading should be less than 200 ohms for each measurements.

CONDITION/INDICATION

IS TRAILER LIGHTING SYSTEM CABLE IN GOOD CONDITION?

DECISION

NO - Replace defective trailer connecting cable. Go to Step (7) to verify problem is solved.
 YES - Go to Step (6).

STEP

6. IS WIRING FROM MAIN SWITCH TO LAMP IN GOOD CONDITION?

NOTE

Perform these steps if faulty trailer is available.

- a. Check for battery voltage at non-operating lamp holder.
- b. Connect trailer lighting system cable to vehicle trailer receptacle and trailer.
- c. Remove faulty circuit lamp.
- d. Place battery switch to ON position.

ONE OR MORE TRAILER LIGHTS INOPERATIVE - Continued

- e. Place truck main light switch in position corresponding to inoperative system on trailer.
- f. Set up multimeter to measure VDC.

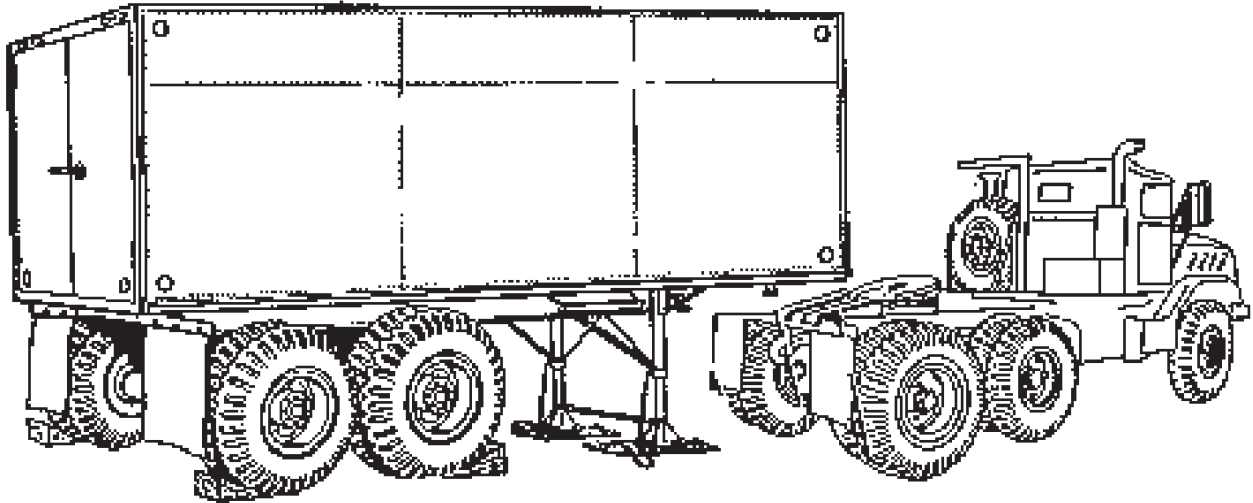

T0119DAA

Figure 6. Trailer.

- g. Connect multimeter red lead to center contact inside lamp holder or wire connector.
- h. Connect multimeter black lead to good ground.

NOTE

- For stoplight circuit test, air pressure must be maintained at operating pressure and brake pedal must be depressed.
 - If voltage is present, wiring to the lamp is in good condition.
- i. Meter reading should be greater than 18 VDC.

CONDITION/INDICATION

IS WIRING FROM MAIN SWITCH TO LAMP IN GOOD CONDITION?

DECISION

NO - Notify supervisor. Perform trailer lighting troubleshooting.
YES - Replace faulty lamp.

ONE OR MORE TRAILER LIGHTS INOPERATIVE - Continued**STEP**

7. IS YOUR ORIGINAL LIGHTING PROBLEM STILL PRESENT?
 - a. Ensure vehicle is returned to normal operating condition.
 - b. Check to see if your original lighting problem still exists.

CONDITION/INDICATION

IS YOUR ORIGINAL LIGHTING PROBLEM STILL PRESENT?

DECISION

YES - Notify supervisor.
NO - Problem fixed.

END OF WORK PACKAGE

FIELD MAINTENANCE
HEATER WILL NOT OPERATE WITH SWITCH IN LOW POSITION (HIGH POSITION OPERATION NORMAL)

INITIAL SETUP:**Tools and Special Tools**

Tool Kit, General Mechanic's: Automotive
(Volume 5, WP 0826, Table 1, Item 56)
Multimeter
(Volume 5, WP 0826, Table 1, Item 34)
Test Set, Electronic Systems
(Volume 5, WP 0826, Table 1, Item 51)

References (cont.)

Volume 2, WP 0307
Volume 3, WP 0352

Equipment Condition

Vehicle parked and engine shut down.
(TM 9-2320-272-10)

Personnel Required

(2)

References

Point to Point Schematics

TROUBLESHOOTING PROCEDURE**HEATER WILL NOT OPERATE WITH SWITCH IN LOW POSITION (HIGH POSITION OPERATION NORMAL)****NOTE**

Conduct these malfunction tests if heater will not operate with switch in low position. This procedure will check for faulty heater switch, faulty circuit 569A wire, defective circuit breaker or battery switch.

HEATER WILL NOT OPERATE WITH SWITCH IN LOW POSITION (HIGH POSITION OPERATION NORMAL) - Continued

STEP

1. DOES CIRCUIT 569A WIRE SUPPLY PROPER VOLTAGE TO HEATER SWITCH?
 - a. Check for 12 or 13 volts at circuit 569A wire.
 - b. Place battery switch to OFF position.

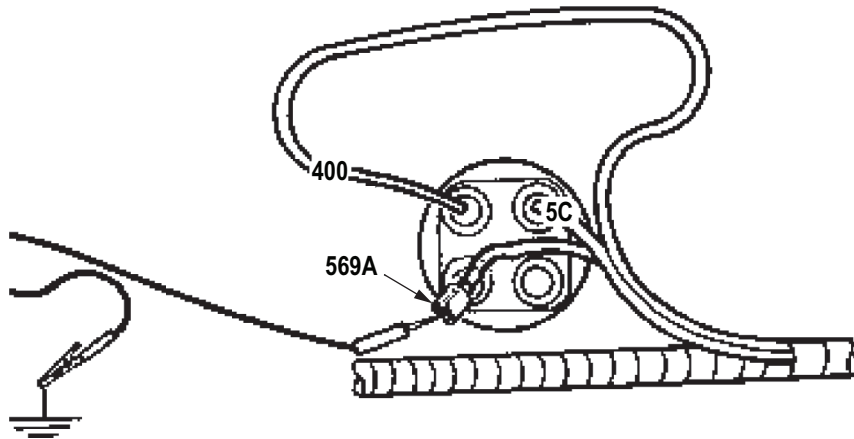

T0125DAA

Figure 1. Heater Switch Wiring.

- c. Disconnect circuit 569A wire from heater switch.
- d. Place battery switch to ON position.
- e. Set up multimeter to measure VDC.
- f. Connect multimeter red lead to the disconnected end of circuit 569A wire. Refer to point to point schematics.
- g. Connect multimeter black lead to vehicle chassis ground.
- h. Meter reading should be 12 VDC or greater.

CONDITION/INDICATION

DOES CIRCUIT 569A WIRE SUPPLY PROPER VOLTAGE TO HEATER SWITCH?

DECISION

NO - Go to Step (2).

YES - Replace heater switch (Volume 2, WP 0307). Go to Step (5) to verify problem is solved.

HEATER WILL NOT OPERATE WITH SWITCH IN LOW POSITION (HIGH POSITION OPERATION NORMAL) - Continued

STEP

2. IS THERE PROPER VOLTAGE AT CIRCUIT 569A TERMINAL OF CIRCUIT BREAKER?
 - a. Place battery switch to OFF position.

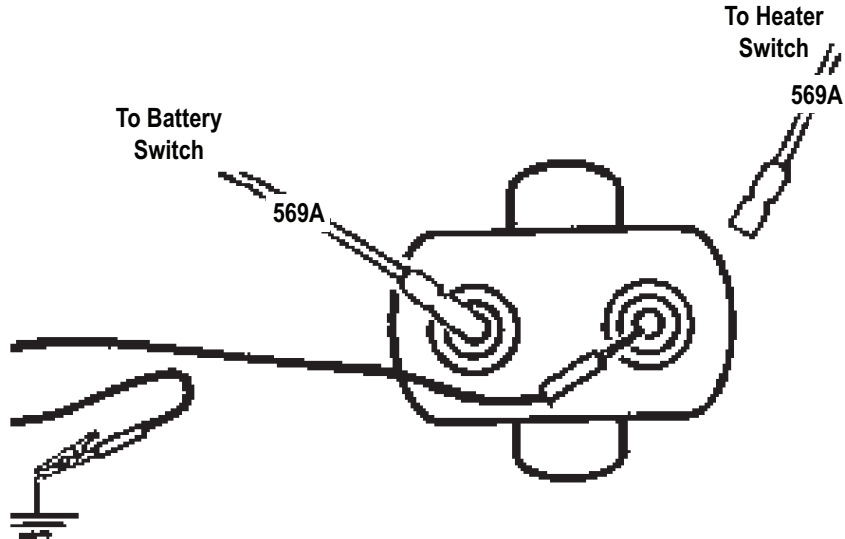

T0126DAA

Figure 2. Circuit Breaker Wire 569A.

- b. Disconnect circuit 569A wire to heater switch from circuit breaker.
- c. Place battery switch to ON position.
- d. Connect multimeter red lead to the open circuit 568A terminal on circuit breaker. Refer to point to point schematics.
- e. Connect multimeter black lead to vehicle chassis ground.
- f. Meter reading should be 12 VDC or greater.

CONDITION/INDICATION

IS THERE PROPER VOLTAGE AT CIRCUIT 569A TERMINAL OF CIRCUIT BREAKER?

DECISION

YES - Repair or replace circuit 569A wire between circuit breaker and heater switch (Volume 3, WP 0352). Go to Step (5) to verify problem is solved.
 NO - Go to Step (3).

HEATER WILL NOT OPERATE WITH SWITCH IN LOW POSITION (HIGH POSITION OPERATION NORMAL) - Continued

STEP

3. IS CIRCUIT BREAKER IN GOOD CONDITION?
- a. Place battery switch to OFF position.

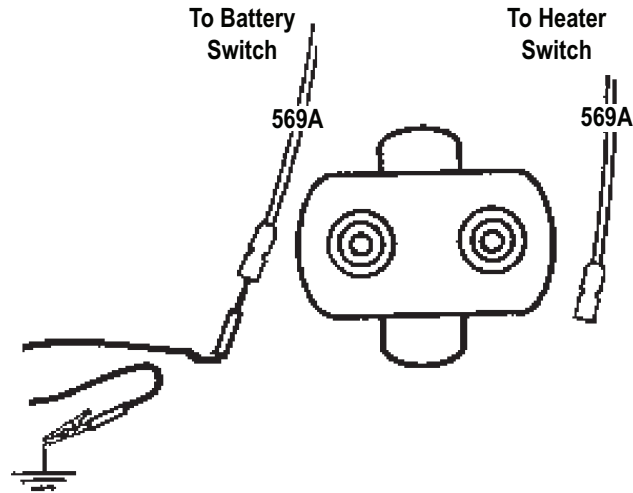

T0127DAA

Figure 3. Circuit Breaker Wire 569A.

- b. Disconnect circuit 569A wire to battery switch from circuit breaker.
- c. Place battery switch to ON position.
- d. Connect multimeter red lead to the disconnected end of circuit 569A wire. Refer to point to point schematics.
- e. Connect multimeter black lead to vehicle chassis ground.

NOTE

If voltage is present, circuit breaker is faulty.

- f. Meter reading should be 12 VDC or greater.

CONDITION/INDICATION

IS CIRCUIT BREAKER IN GOOD CONDITION?

DECISION

NO - Replace circuit breaker (Volume 2, WP 0307). Go to Step (5) to verify problem is solved.

YES - Go to Step (4).

HEATER WILL NOT OPERATE WITH SWITCH IN LOW POSITION (HIGH POSITION OPERATION NORMAL) - Continued**STEP**

4. IS THERE BATTERY VOLTAGE AT BATTERY SWITCH TERMINAL?
 - a. Place battery switch to OFF position.

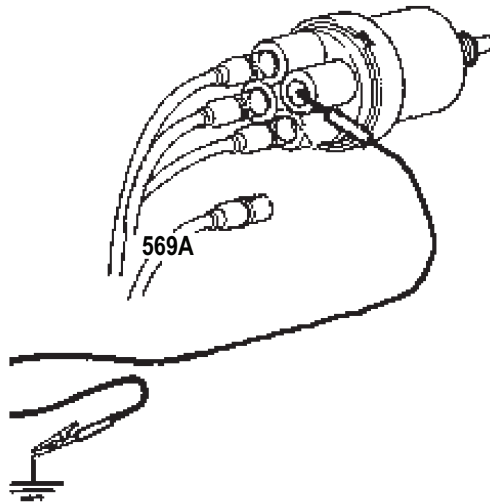

T0128DAA

Figure 4. Battery Switch Wire 569A.

- b. Disconnect circuit 569A wire to circuit breaker from battery switch.
- c. Place battery switch to ON position.
- d. Connect multimeter red lead to the open circuit 569A wire contact (D) on battery switch. Refer to point to point schematics.
- e. Connect multimeter black lead to vehicle chassis ground.
- f. Meter reading should be 12 VDC or greater.

CONDITION/INDICATION

IS THERE BATTERY VOLTAGE AT BATTERY SWITCH TERMINAL?

DECISION

NO - Replace defective battery switch (Volume 2, WP 0307). Go to Step (5) to verify problem is solved.
YES - Repair or replace circuit 569A wire from battery switch to circuit breaker (Volume 3, WP 0352). Go to Step (5) to verify problem is solved.

**HEATER WILL NOT OPERATE WITH SWITCH IN LOW POSITION (HIGH POSITION OPERATION NORMAL) -
Continued**

STEP

5. IS YOUR ORIGINAL HEATER PROBLEM STILL PRESENT?
 - a. Ensure vehicle is returned to normal operating condition.
 - b. Check to see if your original heater problem still exists.

CONDITION/INDICATION

IS YOUR ORIGINAL HEATER PROBLEM STILL PRESENT?

DECISION

YES - Notify supervisor.
NO - Problem fixed.

END OF WORK PACKAGE

FIELD MAINTENANCE
HEATER WILL NOT OPERATE WITH SWITCH IN HIGH POSITION (LOW POSITION OPERATION NORMAL)

INITIAL SETUP:**Tools and Special Tools**

Tool Kit, General Mechanic's: Automotive
(Volume 5, WP 0826, Table 1, Item 56)
Multimeter
(Volume 5, WP 0826, Table 1, Item 34)
Test Set, Electronic Systems
(Volume 5, WP 0826, Table 1, Item 51)

References (cont.)

Volume 2, WP 0307
Volume 3, WP 0352

Equipment Condition

Vehicle parked and engine shut down.
(TM 9-2320-272-10)

Personnel Required

(2)

References

Point to Point Schematics

TROUBLESHOOTING PROCEDURE**HEATER WILL NOT OPERATE WITH SWITCH IN HIGH POSITION (LOW POSITION OPERATION NORMAL)****NOTE**

Conduct these malfunction tests if heater will not operate with switch in high position. This procedure will check for faulty heater switch, faulty circuit 5C/27 wire, and defective circuit breaker.

HEATER WILL NOT OPERATE WITH SWITCH IN HIGH POSITION (LOW POSITION OPERATION NORMAL) - Continued

STEP

1. DOES CIRCUIT 5C WIRE SUPPLY PROPER VOLTAGE TO HEATER SWITCH?
 - a. Check for battery voltage at circuit 5C wire.
 - b. Place battery switch to OFF position.

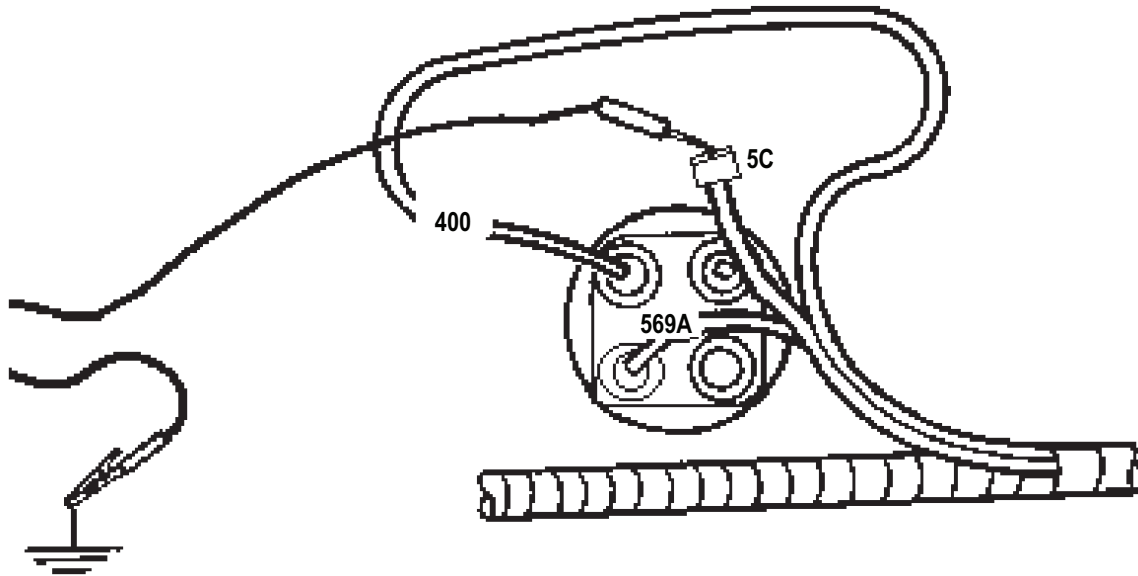

T0130DAA

Figure 1. Heater Switch Wiring.

- c. Disconnect circuit 5C wire from heater switch.
- d. Place battery switch to ON position.
- e. Set up multimeter to measure VDC.
- f. Connect multimeter red lead to the disconnected end of circuit 5C wire. Refer to point to point schematics.
- g. Connect multimeter black lead to vehicle chassis ground.
- h. Meter reading should be greater than 18 VDC.

CONDITION/INDICATION

DOES CIRCUIT 5C WIRE SUPPLY PROPER VOLTAGE TO HEATER SWITCH?

DECISION

NO - Go to Step (2).

YES - Replace heater switch (Volume 2, WP 0307). Go to Step (4) to verify problem is solved.

HEATER WILL NOT OPERATE WITH SWITCH IN HIGH POSITION (LOW POSITION OPERATION NORMAL) - Continued

STEP

2. IS THERE BATTERY VOLTAGE AT CIRCUIT 27 TERMINAL OF CIRCUIT BREAKER?
 - a. Check for battery voltage from circuit breaker.
 - b. Place battery switch to OFF position.
 - c. Visually inspect circuit 5C and 27 wires for damaged or frayed condition.

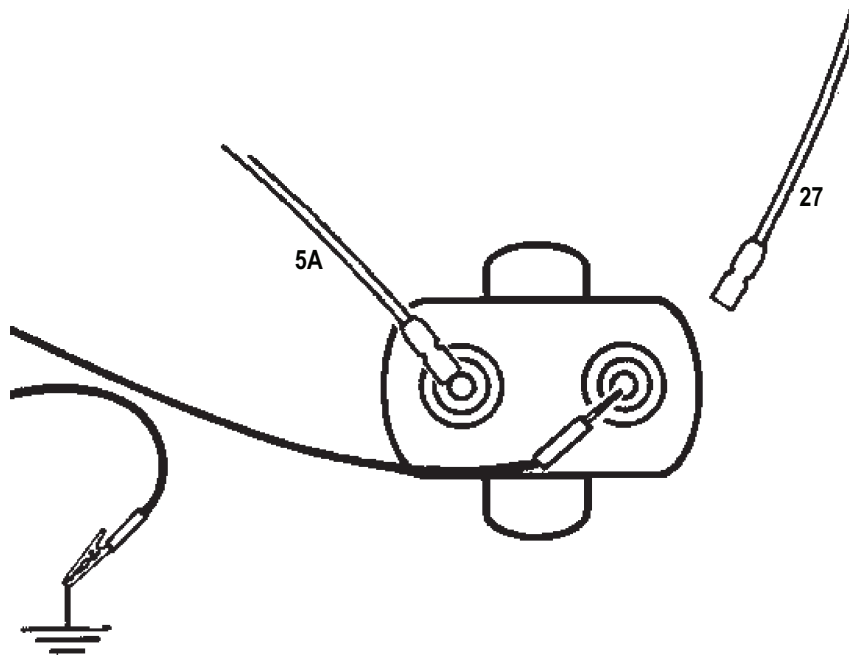

T0131DAA

Figure 2. Circuit Breaker Wire 27.

- d. Disconnect circuit 27 wire from circuit breaker.
- e. Place battery switch to ON position.
- f. Connect multimeter red lead to the open circuit 27 terminal on circuit breaker. Refer to point to point schematics.
- g. Connect multimeter black lead to vehicle chassis ground.
- h. Meter reading should be greater than 18 VDC.

CONDITION/INDICATION

IS THERE BATTERY VOLTAGE AT CIRCUIT 27 TERMINAL OF CIRCUIT BREAKER?

DECISION

YES - Repair or replace circuit 5C and 27 wire between circuit breaker and heater switch (Volume 3, WP 0352). Go to Step (4) to verify problem is solved.
 NO - Go to Step (3).

HEATER WILL NOT OPERATE WITH SWITCH IN HIGH POSITION (LOW POSITION OPERATION NORMAL) - Continued

STEP

3. IS CIRCUIT BREAKER IN GOOD CONDITION?
 - a. Check for battery voltage at circuit 5A wire.
 - b. Place battery switch to OFF position.

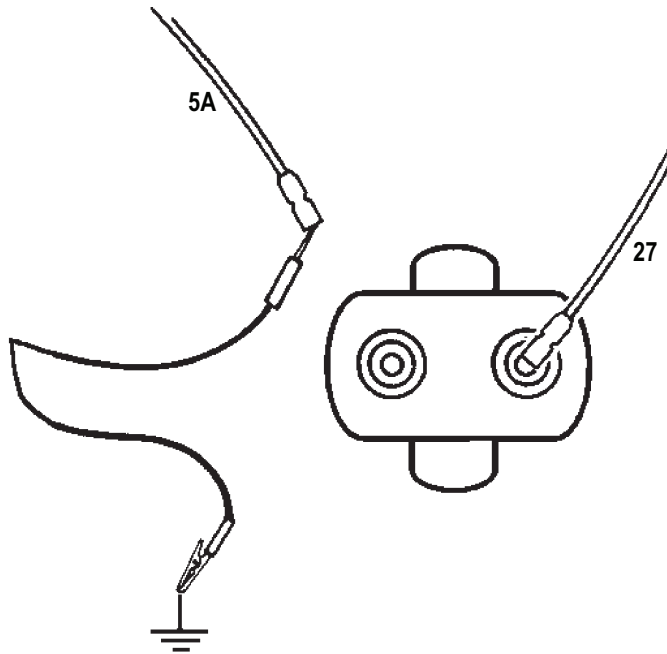

T0132DAA

Figure 3. Circuit Breaker Wire 5A.

- c. Disconnect circuit 5A wire to battery switch from circuit breaker.
- d. Place battery switch to ON position.
- e. Connect multimeter red lead to the disconnected end of circuit 5A wire. Refer to point to point schematics.
- f. Connect multimeter black lead to vehicle chassis ground.

NOTE

If voltage is present, circuit breaker is faulty.

- g. Meter reading should be greater than 18 VDC.

CONDITION/INDICATION

IS CIRCUIT BREAKER IN GOOD CONDITION?

DECISION

NO - Replace circuit breaker (Volume 2, WP 0307). Go to Step (4) to verify problem is solved.

YES - Repair or replace circuit 5A wire (Volume 3, WP 0352). Go to Step (4) to verify problem is solved.

**HEATER WILL NOT OPERATE WITH SWITCH IN HIGH POSITION (LOW POSITION OPERATION NORMAL) -
Continued**

STEP

4. IS YOUR ORIGINAL HEATER PROBLEM STILL PRESENT?
 - a. Ensure vehicle is returned to normal operating condition.
 - b. Check to see if your original heater problem still exists.

CONDITION/INDICATION

IS YOUR ORIGINAL HEATER PROBLEM STILL PRESENT?

DECISION

YES - Notify supervisor.
NO - Problem fixed.

END OF WORK PACKAGE

FIELD MAINTENANCE
HEATER WILL NOT OPERATE IN LOW OR HIGH POSITION

INITIAL SETUP:**Tools and Special Tools**

Tool Kit, General Mechanic's: Automotive
(Volume 5, WP 0826, Table 1, Item 56)
Multimeter
(Volume 5, WP 0826, Table 1, Item 34)
Test Set, Electronic Systems
(Volume 5, WP 0826, Table 1, Item 51)

References (cont.)

Volume 2, WP 0307
Volume 3, WP 0352
Volume 4, WP 0747

Equipment Condition

Vehicle parked and engine shut down.
(TM 9-2320-272-10)

Personnel Required

(2)

References

Point to Point Schematics

TROUBLESHOOTING PROCEDURE**HEATER WILL NOT OPERATE IN LOW OR HIGH POSITION****NOTE**

Conduct these malfunction tests if heater will not operate in low or high position. This procedure will check for faulty heater switch, faulty wiring, or faulty heater.

HEATER WILL NOT OPERATE IN LOW OR HIGH POSITION - Continued**STEP**

1. IS HEATER BLOWER MOTOR IN GOOD OPERATING CONDITION?
 - a. Check for proper voltage supply from circuit 400 wire terminal at heater blower motor.
 - b. Place battery switch to OFF position.

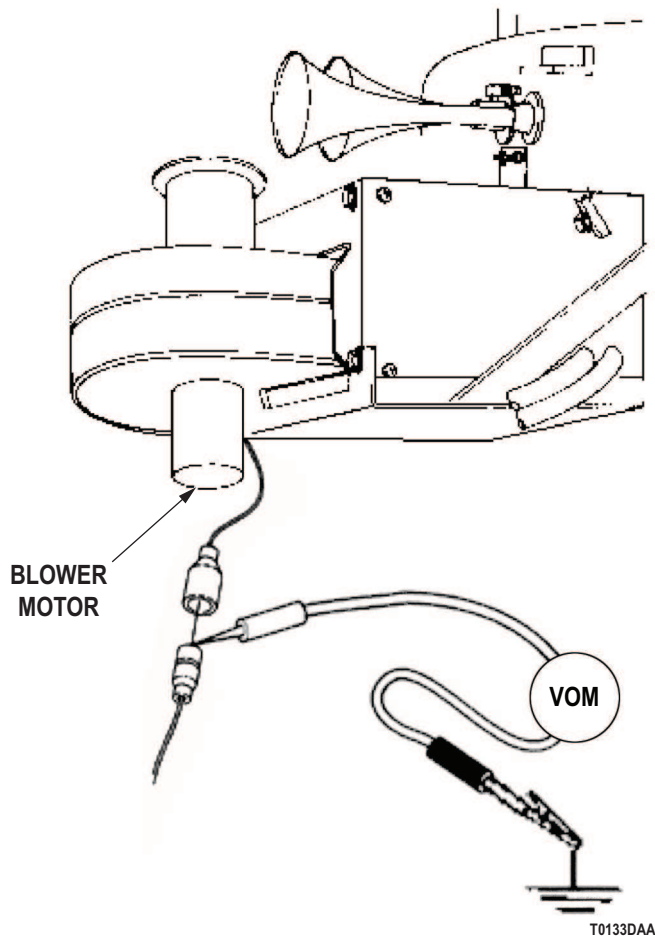

Figure 1. Heater Blower Motor Wiring.

HEATER WILL NOT OPERATE IN LOW OR HIGH POSITION - Continued

- c. Disconnect circuit 400 wire from heater blower motor.
- d. Place battery switch to ON position.
- e. Place heater switch to HIGH speed position.
- f. Set up multimeter to measure VDC.
- g. Connect multimeter red lead to the disconnected circuit 400 wire. Refer to point to point schematics.
- h. Connect multimeter black lead to vehicle chassis ground.

NOTE

If voltage is present, heater blower motor is faulty.

- i. Meter reading should be greater than 18 VDC.

CONDITION/INDICATION

IS HEATER BLOWER MOTOR IN GOOD OPERATING CONDITION?

DECISION

NO - Replace heater blower motor (Volume 4, WP 0747). Go to Step (3) to verify problem is solved.
YES - Go to Step (2).

HEATER WILL NOT OPERATE IN LOW OR HIGH POSITION - Continued**STEP**

2. IS HEATER SWITCH IN GOOD OPERATING CONDITION?
 - a. Check for proper voltage supply from circuit 400 wire terminal on heater switch.
 - b. Place battery switch to OFF position.

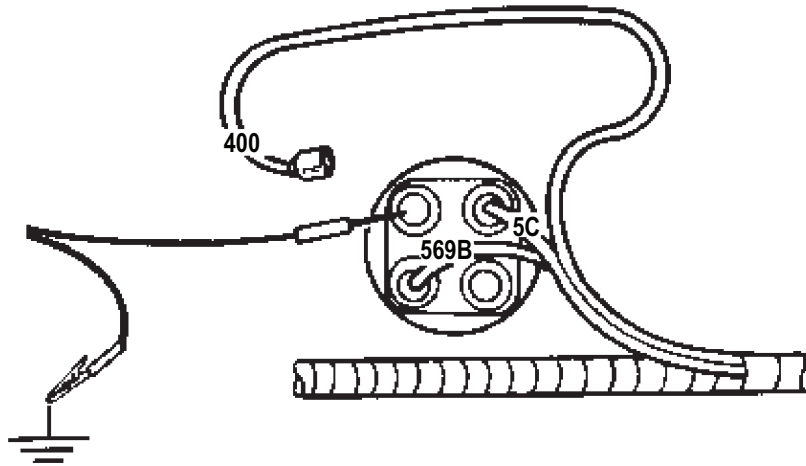

T0134DAA

Figure 2. Heater Switch Wiring.

- c. Disconnect circuit 400 wire from heater switch.
- d. Place battery switch to ON position.
- e. Place heater switch to HIGH speed position.
- f. Connect multimeter red lead to the circuit 400 wire terminal at the heater switch. Refer to point to point schematics.
- g. Connect multimeter black lead to vehicle chassis ground.

NOTE

If voltage is not present, heater switch motor is faulty.

- h. Meter reading should be greater than 18 VDC.

HEATER WILL NOT OPERATE IN LOW OR HIGH POSITION - Continued**CONDITION/INDICATION**

IS HEATER SWITCH IN GOOD OPERATING CONDITION?

DECISION

NO - Replace heater switch (Volume 2, WP 0307). Go to Step (3) to verify problem is solved.

YES - Repair or replace circuit wire 400 (Volume 3, WP 0352). Go to Step (3) to verify problem is solved.

STEP

3. IS YOUR ORIGINAL HEATER PROBLEM STILL PRESENT?
 - a. Ensure vehicle is returned to normal operating condition.
 - b. Check to see if your original heater problem still exists.

CONDITION/INDICATION

IS YOUR ORIGINAL HEATER PROBLEM STILL PRESENT?

DECISION

YES - Notify supervisor.

NO - Problem fixed.

END OF WORK PACKAGE

FIELD MAINTENANCE
NO CAB HEAT (COOLANT TEMPERATURE GAUGE READS NORMAL)

INITIAL SETUP:**Tools and Special Tools**

Tool Kit, General Mechanic's: Automotive
(Volume 5, WP 0826, Table 1, Item 56)

Equipment Condition

Vehicle parked and engine shut down.
(TM 9-2320-272-10)

Personnel Required

(2)

References

TM 9-2320-272-10
Volume 2, WP 0287

TROUBLESHOOTING PROCEDURE**NO CAB HEAT (COOLANT TEMPERATURE GAUGE READS NORMAL)****NOTE**

Conduct these malfunction tests if there is no cab heat and coolant temperature gauge reads normal. This procedure will check for position of engine coolant shutoff valves, air in personnel heater system, engine coolant level.

NO CAB HEAT (COOLANT TEMPERATURE GAUGE READS NORMAL) - Continued**STEP**

1. ARE ENGINE COOLANT SHUTOFF VALVES IN OPEN POSITION?
 - a. Visually check position of engine coolant shutoff valves.

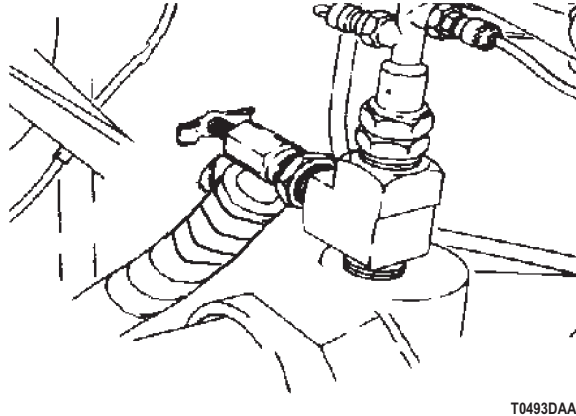

Figure 1. Engine Coolant Shutoff Valve.

- b. Check if valves are in the open position.

CONDITION/INDICATION

ARE ENGINE COOLANT SHUTOFF VALVES IN OPEN POSITION?

DECISION

YES - Go to Step (2).

NO - Open engine coolant shutoff valves (TM 9-2320-272-10). Go to Step (3) to verify problem is solved.

STEP

2. IS ENGINE COOLANT AT PROPER LEVEL?
 - a. Bleed air from personnel heater.

CAUTION

Do not add coolant when engine is hot. Internal engine damage could result.

- b. Visually check engine coolant level.

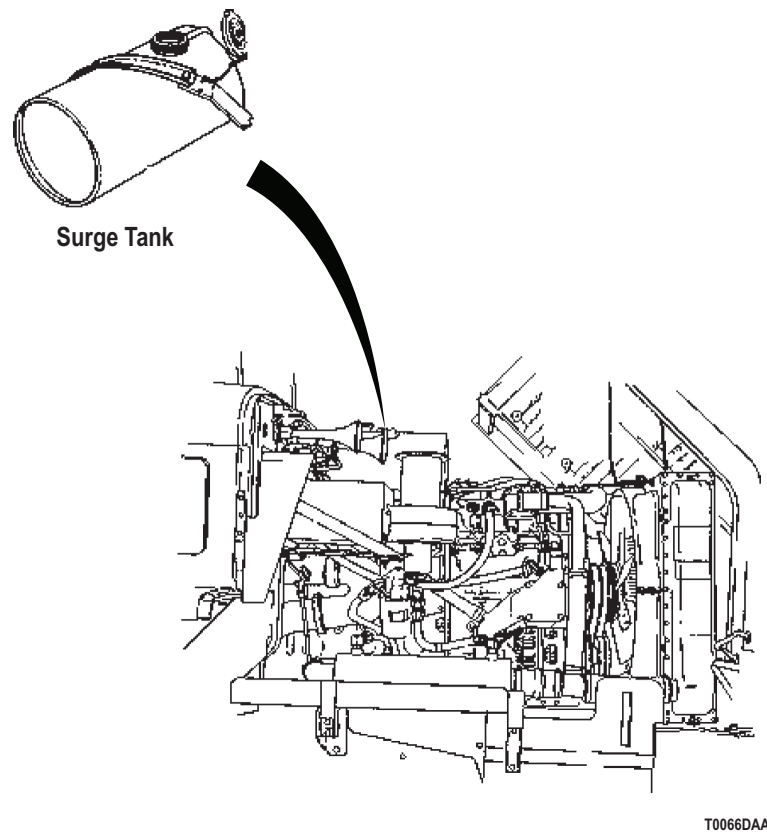
NO CAB HEAT (COOLANT TEMPERATURE GAUGE READS NORMAL) - Continued

T0066DAA

*Figure 2. Coolant Level.***CONDITION/INDICATION**

IS ENGINE COOLANT AT PROPER LEVEL?

DECISION

YES - Go to Step (3) to verify problem is solved.

NO - Fill coolant to proper level (Volume 2, WP 0287). Go to Step (3) to verify problem is solved.

NO CAB HEAT (COOLANT TEMPERATURE GAUGE READS NORMAL) - Continued**STEP**

3. IS YOUR ORIGINAL NO CAB HEAT PROBLEM STILL PRESENT?
 - a. Ensure vehicle is returned to normal operating condition.
 - b. Check to see if your original no cab heat problem still exists.

CONDITION/INDICATION

IS YOUR ORIGINAL NO CAB HEAT PROBLEM STILL PRESENT?

DECISION

YES - Notify supervisor.
NO - Problem fixed.

END OF WORK PACKAGE

FIELD MAINTENANCE
PARKING BRAKE DOES NOT HOLD VEHICLE ON GRADE

INITIAL SETUP:**Tools and Special Tools**

Tool Kit, General Mechanic's: Automotive
(Volume 5, WP 0826, Table 1, Item 56)

References (cont.)

Volume 3, WP 0420
Volume 3, WP 0421
Volume 3, WP 0422

Personnel Required

(2)

Equipment Condition

Vehicle parked and engine shut down.
(TM 9-2320-272-10)

References

WP 0136

TROUBLESHOOTING PROCEDURE**PARKING BRAKE DOES NOT HOLD VEHICLE ON GRADE****NOTE**

Conduct these malfunction tests if parking brake does not hold vehicle on grade. This procedure will check for improper parking brake adjustment, damage to parking brake cable, worn or damaged brakeshoes and broken or faulty actuating plate.

PARKING BRAKE DOES NOT HOLD VEHICLE ON GRADE - Continued**STEP****1. IS PARKING BRAKE PROPERLY ADJUSTED?**

- a. Visually check for proper adjustment of parking brake.

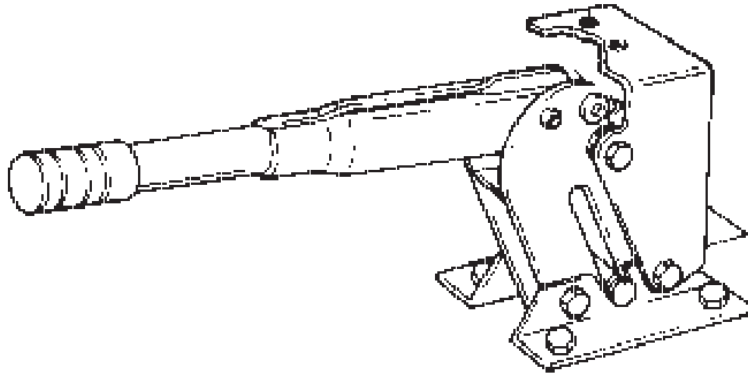

T0180DAA

Figure 1. Brake Lever.

- b. Turn knob on top of parking brake lever clockwise to increase braking action (Volume 3, WP 0420).
- c. Check to see if parking brake holds vehicle.
- d. If problem is corrected, parking brake was not adjusted properly.

CONDITION/INDICATION

IS PARKING BRAKE PROPERLY ADJUSTED?

DECISION

- NO - Go to Step (5) to verify problem is solved.
YES - Go to Step (2).

PARKING BRAKE DOES NOT HOLD VEHICLE ON GRADE - Continued**STEP****2. IS PARKING BRAKE CABLE IN GOOD OPERATING CONDITION?**

Visually check parking brake cable for binding or breaks.

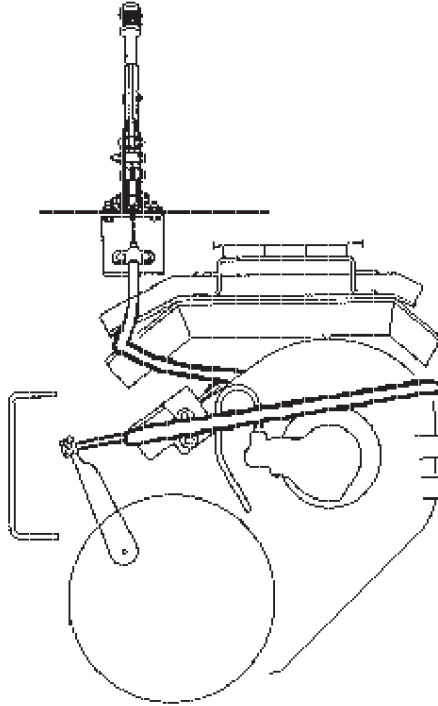

T0181DAA

Figure 2. Parking Brake Cable Assembly.

CONDITION/INDICATION

IS PARKING BRAKE CABLE IN GOOD OPERATING CONDITION?

DECISION

NO - Repair or replace parking brake cable (Volume 3, WP 0421). Go to Step (5) to verify problem is solved.
YES - Go to Step (3).

PARKING BRAKE DOES NOT HOLD VEHICLE ON GRADE - Continued**STEP**

3. ARE PARKING BRAKE SHOES IN GOOD CONDITION?
 - a. Check for worn parking brakeshoes.

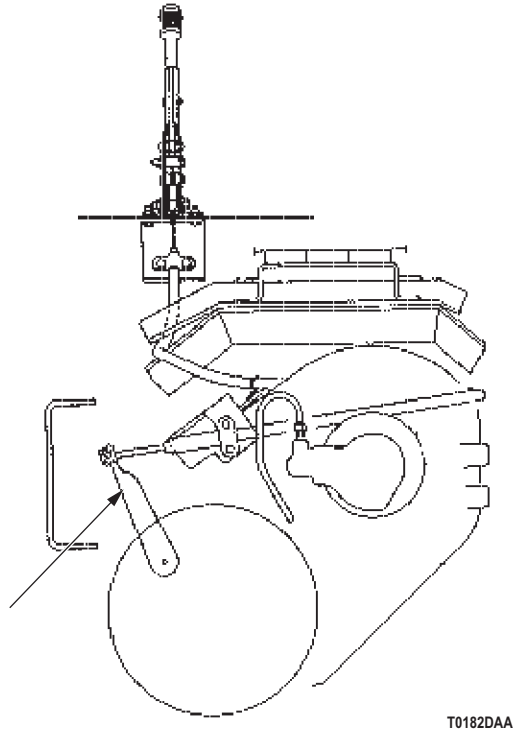

Figure 3. Parking Brake Assembly.

- b. Push parking brake lever clockwise by hand and measure brake lever travel.
 - c. If parking brake lever travels less than 2 in., parking brakeshoes are OK.

CONDITION/INDICATION

ARE PARKING BRAKE SHOES IN GOOD CONDITION?

DECISION

NO - Replace parking brakeshoes (Volume 3, WP 0422). Go to Step (5) to verify problem is solved.
YES - Go to Step (4).

STEP

4. IS PARKING BRAKE ACTUATING MECHANISM WORKING PROPERLY?

Visually check for broken or faulty actuating plate, lever, and spring.

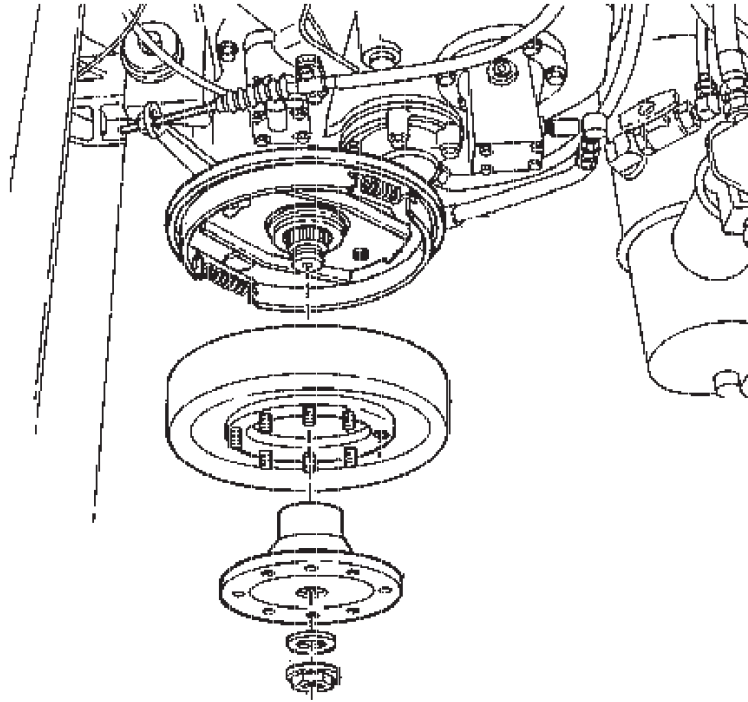
PARKING BRAKE DOES NOT HOLD VEHICLE ON GRADE - Continued

T0183DAA

Figure 4. Parking Brake Actuating Mechanism.

CONDITION/INDICATION

IS PARKING BRAKE ACTUATING MECHANISM WORKING PROPERLY?

DECISION

NO - Notify supervision that parking brake is faulty. Action may not be possible at this level of maintenance.
 YES - Perform Spring Brake troubleshooting (WP 0136).

STEP

5. IS YOUR ORIGINAL PROBLEM STILL PRESENT?
 - a. Ensure vehicle is returned to normal operating condition.
 - b. Check to see if your original parking brake problem still exists.

CONDITION/INDICATION

IS YOUR ORIGINAL PROBLEM STILL PRESENT?

DECISION

YES - Notify supervisor.
 NO - Problem fixed.

END OF WORK PACKAGE

FIELD MAINTENANCE
PARKING BRAKE DRAGS, AS INDICATED BY SMOKING OR BURNING SMELL

INITIAL SETUP:**Tools and Special Tools**

Tool Kit, General Mechanic's: Automotive
(Volume 5, WP 0826, Table 1, Item 56)

References (cont.)

Volume 3, WP 0420
Volume 3, WP 0421

Personnel Required

(2)

Equipment Condition

Vehicle parked and engine shut down.
(TM 9-2320-272-10)

References

WP 0135

TROUBLESHOOTING PROCEDURE**PARKING BRAKE DRAGS, AS INDICATED BY SMOKING OR BURNING SMELL****NOTE**

Conduct these malfunction tests if parking brake drags. This procedure will check for partially engaged parking brake lever, improper parking brake adjustment, damaged or binding parking brake cable and for faulty actuating mechanism.

PARKING BRAKE DRAGS, AS INDICATED BY SMOKING OR BURNING SMELL - Continued**STEP****1. IS PARKING BRAKE FULLY RELEASED?**

- a. Visually check for partially engaged parking brake lever.

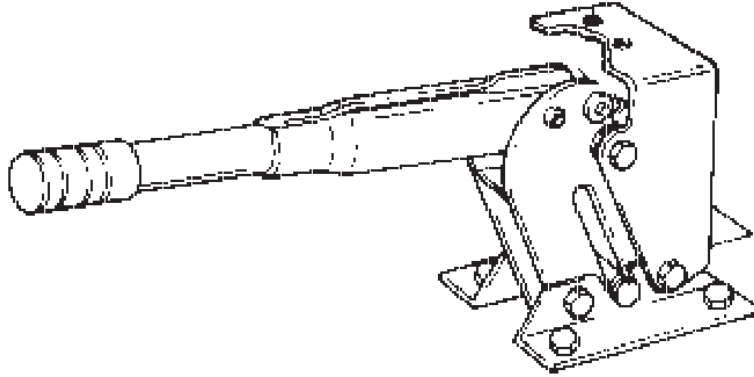

T0185DAA

Figure 1. Brake Lever.

- b. Fully release partially engaged parking brake.
- c. Check to see if parking brake drags.
- d. If problem is corrected, parking brake was not fully released.

CONDITION/INDICATION

IS PARKING BRAKE FULLY RELEASED?

DECISION

- NO - Go to Step (5) to verify problem is solved.
YES - Go to Step (2).

PARKING BRAKE DRAGS, AS INDICATED BY SMOKING OR BURNING SMELL - Continued**STEP**

2. IS PARKING BRAKE PROPERLY ADJUSTED?
 - a. Visually check for proper adjustment of parking brake.

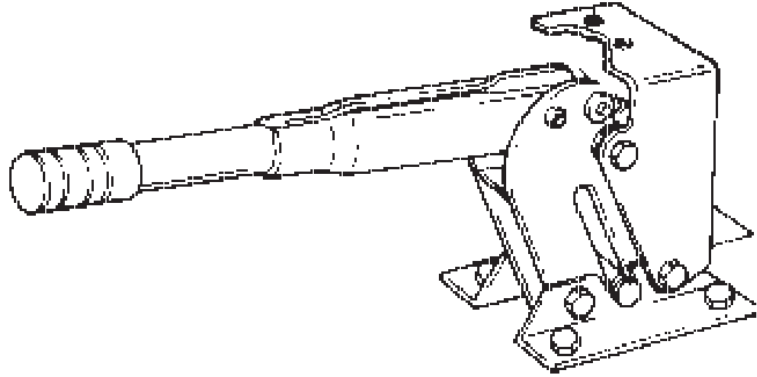

T0185DAA

Figure 2. Brake Lever.

- b. Turn knob on top of parking brake lever clockwise to increase, counter clockwise to decrease braking action (Volume 3, WP 0420).
 - c. Check to see if parking brake drags.
 - d. If problem is corrected, parking brake was not adjusted properly.

CONDITION/INDICATION

IS PARKING BRAKE PROPERLY ADJUSTED?

DECISION

NO - Go to Step (5) to verify problem is solved.
YES - Go to Step (3).

PARKING BRAKE DRAGS, AS INDICATED BY SMOKING OR BURNING SMELL - Continued**STEP****3. IS PARKING BRAKE CABLE IN GOOD OPERATING CONDITION?**

Visually check parking brake cable for binding or breaks.

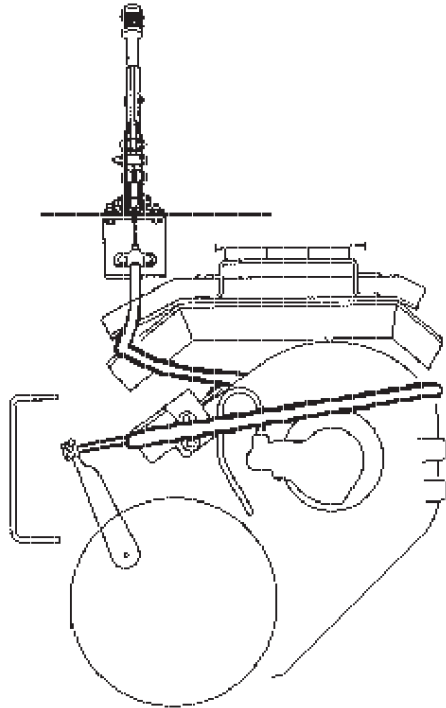

T0186DAA

Figure 3. Parking Brake Cable Assembly.

CONDITION/INDICATION

IS PARKING BRAKE CABLE IN GOOD OPERATING CONDITION?

DECISION

NO - Repair or replace parking brake cable (Volume 3, WP 0421). Go to Step (5) to verify problem is solved.
YES - Go to Step (4).

STEP**4. IS PARKING BRAKE ACTUATING MECHANISM WORKING PROPERLY?**

Visually check for broken or faulty actuating plate, lever, and spring.

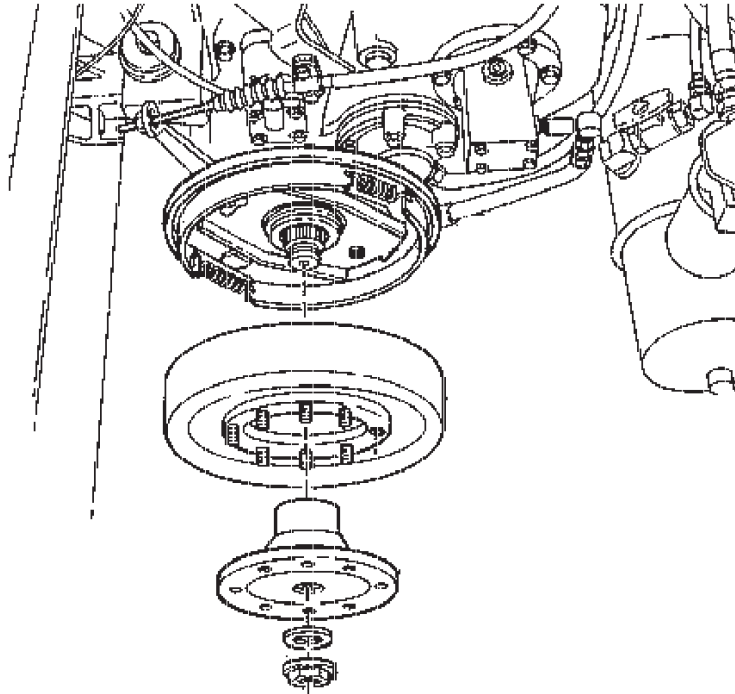
PARKING BRAKE DRAGS, AS INDICATED BY SMOKING OR BURNING SMELL - Continued

T0187DAA

*Figure 4. Parking Brake Actuating Mechanism.***CONDITION/INDICATION**

IS PARKING BRAKE ACTUATING MECHANISM WORKING PROPERLY?

DECISION

NO - Notify supervision that parking brake is faulty. Action may not be possible at this level of maintenance.
 YES - Perform Spring Brakes Do Not Release troubleshooting (WP 0135).

STEP

5. IS YOUR ORIGINAL PROBLEM STILL PRESENT?
 - a. Ensure vehicle is returned to normal operating condition.
 - b. Check to see if your original parking brake problem still exists.

CONDITION/INDICATION

IS YOUR ORIGINAL PROBLEM STILL PRESENT?

DECISION

YES - Notify supervisor.
 NO - Problem fixed.

END OF WORK PACKAGE

FIELD MAINTENANCE
INSUFFICIENT BRAKES (VEHICLE STOPPING DISTANCE TOO LONG, NO APPARENT AIR SYSTEM FAILURE WITH GAUGES AT NORMAL OPERATING PRESSURE, WARNING BUZZER NOT SOUNDING)

INITIAL SETUP:**Tools and Special Tools**

Tool Kit, General Mechanic's: Automotive
 (Volume 5, WP 0826, Table 1, Item 56)
 Gauge, Pressure
 (Volume 5, WP 0826, Table 1, Item 19)
 Test Set, Electronic Systems
 (Volume 5, WP 0826, Table 1, Item 51)

Personnel Required

(2)

References

Point to Point Schematics
 Volume 3, WP 0424

References (cont.)

Volume 3, WP 0426
 Volume 3, WP 0429
 Volume 3, WP 0430
 Volume 3, WP 0434
 Volume 3, WP 0435
 Volume 3, WP 0439
 Volume 3, WP 0457
 Volume 3, WP 0458
 Volume 5, WP 0805

Equipment Condition

Vehicle parked and engine shut down.
 (TM 9-2320-272-10)

TROUBLESHOOTING PROCEDURE

INSUFFICIENT BRAKES (VEHICLE STOPPING DISTANCE TOO LONG, NO APPARENT AIR SYSTEM FAILURE WITH GAUGES AT NORMAL OPERATING PRESSURE, WARNING BUZZER NOT SOUNDING)

NOTE

Conduct these malfunction tests if the vehicle appears to have insufficient brakes and there is no apparent air system failure. This procedure will check for air leaks in lines, hoses, and service brake chamber vent lines. Front service brake chamber pressure, service brake chamber pressure, spring and service brake chamber pressure, limiting valve venting, limiting valve air delivery pressure, limiting valve air supply pressure, double check valve #1 air supply pressure, service brake pedal valve primary air system delivery port pressure, primary air system relay valve pressure, primary air tank to relay valve supply line pressure, secondary air system relay valve pressure, secondary air tank to relay valve supply line pressure, and the brake mechanism will also be checked.

INSUFFICIENT BRAKES (VEHICLE STOPPING DISTANCE TOO LONG, NO APPARENT AIR SYSTEM FAILURE WITH GAUGES AT NORMAL OPERATING PRESSURE, WARNING BUZZER NOT SOUNDING) - Continued

STEP

1. DO ANY AIR LINES OR HOSES LEAK?
 - a. Start engine and run to build air supply to normal operating pressure.
 - b. Assistant fully applies service brakes.
 - c. Listen for leaking air lines or fittings. Refer to point to point schematics.

CONDITION/INDICATION

DO ANY AIR LINES OR HOSES LEAK?

DECISION

YES - Replace damaged air lines (Volume 5, WP 0805). Go to Step (30) to verify problem is solved.
NO - Go to Step (2).

STEP

2. DOES AIR LEAK THROUGH SERVICE BRAKE CHAMBER VENT LINES?
 - a. Disconnect vent line from right front service brake chamber (Volume 3, WP 0434). Refer to point to point schematics.

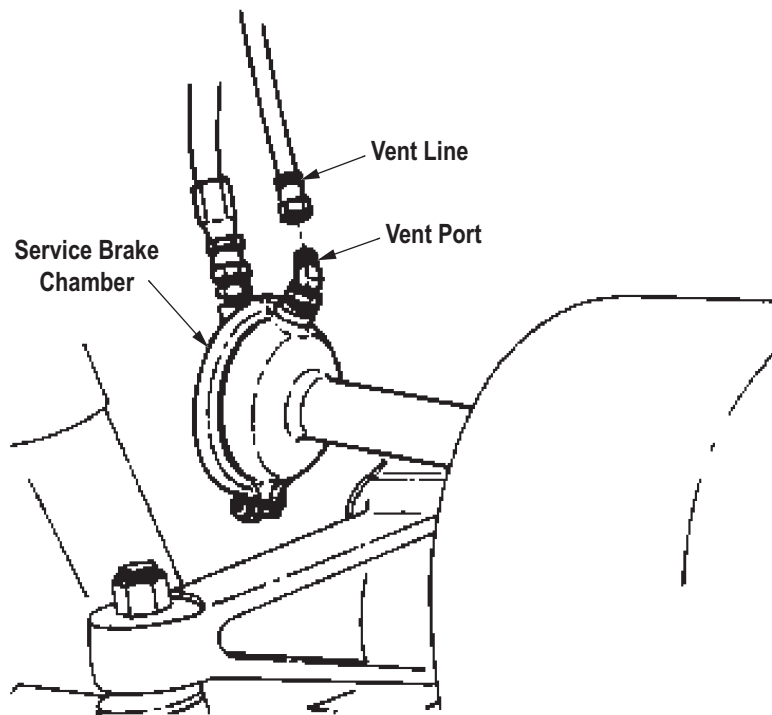

T0201DAA

Figure 1. Service Brake Chamber Vent Line.

INSUFFICIENT BRAKES (VEHICLE STOPPING DISTANCE TOO LONG, NO APPARENT AIR SYSTEM FAILURE WITH GAUGES AT NORMAL OPERATING PRESSURE, WARNING BUZZER NOT SOUNDING) - Continued

NOTE

Air pressure to service brake chambers must compare with reading on primary air pressure gauge. Air pressure to spring and service brake chambers must compare with reading on secondary air pressure gauge.

- b. Assistant applies service brakes and feels for evidence of escaping air at vent port.
- c. Connect vent line to service brake chamber.
- d. Check vent lines on all service brake chambers. Note any chambers that leak air.

CONDITION/INDICATION

DOES AIR LEAK THROUGH SERVICE BRAKE CHAMBER VENT LINES?

DECISION

YES - Service brake chamber leaks. Replace leaking brake chamber (Volume 3, WP 0434). Go to Step (30) to verify problem is solved.

YES - Service and spring brake chamber leaks. Replace leaking brake chamber (Volume 3, WP 0435). Go to Step (30) to verify problem is solved.

NO - Go to Step (3).

INSUFFICIENT BRAKES (VEHICLE STOPPING DISTANCE TOO LONG, NO APPARENT AIR SYSTEM FAILURE WITH GAUGES AT NORMAL OPERATING PRESSURE, WARNING BUZZER NOT SOUNDING) - Continued

STEP

3. IS THERE PROPER AIR PRESSURE AT THE RIGHT FRONT SERVICE BRAKE CHAMBER?
 - a. Stop engine and open all draincocks until brake system air pressure is vented.
 - b. Close all draincocks.

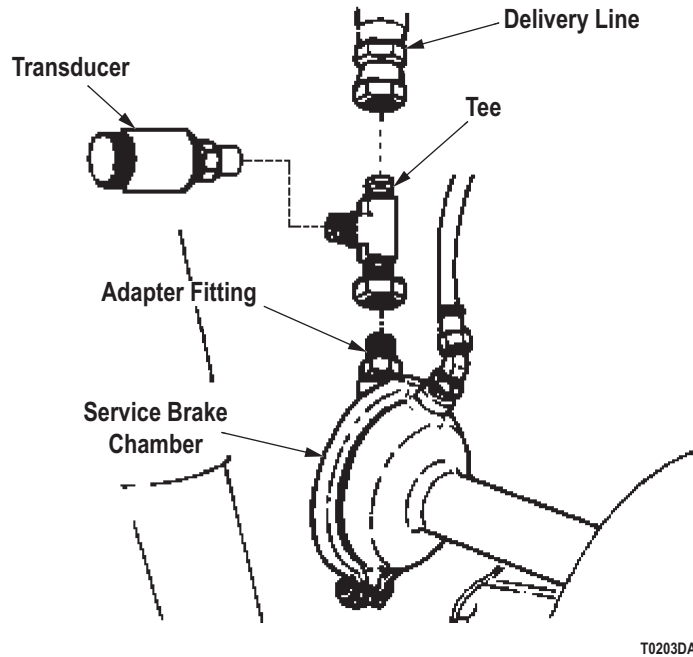

T0203DAA

Figure 2. Front Service Brake Chamber.

- c. Disconnect delivery line from right service brake chamber adapter fitting (Volume 3, WP 0434). Refer to point to point schematics.
- d. Connect tee between disconnected service brake chamber and delivery line.
- e. Connect pressure gauge to tee.
- f. Assistant starts engine and runs to build air supply to normal operating pressure.

INSUFFICIENT BRAKES (VEHICLE STOPPING DISTANCE TOO LONG, NO APPARENT AIR SYSTEM FAILURE WITH GAUGES AT NORMAL OPERATING PRESSURE, WARNING BUZZER NOT SOUNDING) - Continued

NOTE

Air pressure to service brake chambers must compare with reading on primary air pressure gauge. Air pressure to spring and service brake chambers must compare with reading on secondary air pressure gauge.

- g. Assistant fully applies and holds service brakes while comparing pressure gauge reading to instrument panel primary air pressure gauge reading.
- h. Pressure gauge should read 90 to 130 psi.
- i. Both readings should be similar.

CONDITION/INDICATION

IS THERE PROPER AIR PRESSURE AT THE RIGHT FRONT SERVICE BRAKE CHAMBER?

DECISION

NO - Go to Step (17).

YES - Go to Step (4).

INSUFFICIENT BRAKES (VEHICLE STOPPING DISTANCE TOO LONG, NO APPARENT AIR SYSTEM FAILURE WITH GAUGES AT NORMAL OPERATING PRESSURE, WARNING BUZZER NOT SOUNDING) - Continued

STEP

4. IS THERE PROPER AIR PRESSURE AT THE LEFT FRONT SERVICE BRAKE CHAMBER?
 - a. Stop engine and open all draincocks until brake system air pressure is vented.
 - b. Close all draincocks.

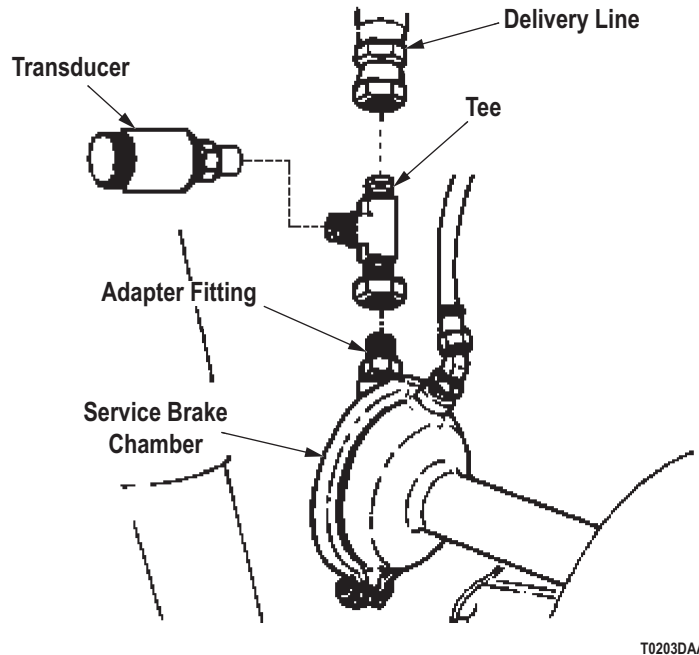

Figure 3. Front Service Brake Chamber.

- c. Disconnect delivery line from left service brake chamber adapter fitting (Volume 3, WP 0434). Refer to point to point schematics.
- d. Disconnect pressure gauge and tee from vehicle and return air line to original condition.
- e. Move tee to between disconnected service brake chamber and delivery line.
- f. Verify pressure gauge is connected to tee.
- g. Assistant starts engine and runs to build air supply to normal operating pressure.

INSUFFICIENT BRAKES (VEHICLE STOPPING DISTANCE TOO LONG, NO APPARENT AIR SYSTEM FAILURE WITH GAUGES AT NORMAL OPERATING PRESSURE, WARNING BUZZER NOT SOUNDING) - Continued

NOTE

Air pressure to service brake chambers must compare with reading on primary air pressure gauge. Air pressure to spring and service brake chambers must compare with reading on secondary air pressure gauge.

- h. Assistant fully applies and holds service brakes while comparing pressure gauge reading to instrument panel primary air pressure gauge reading.
- i. Pressure gauge should read 90 to 130 psi.
- j. Both readings should be similar.

CONDITION/INDICATION

IS THERE PROPER AIR PRESSURE AT THE LEFT FRONT SERVICE BRAKE CHAMBER?

DECISION

NO - Go to Step (17).

YES - Go to Step (5).

INSUFFICIENT BRAKES (VEHICLE STOPPING DISTANCE TOO LONG, NO APPARENT AIR SYSTEM FAILURE WITH GAUGES AT NORMAL OPERATING PRESSURE, WARNING BUZZER NOT SOUNDING) - Continued

STEP

5. IS THERE PROPER AIR PRESSURE AT THE RIGHT FORWARD-REAR REAR SERVICE BRAKE CHAMBER?
 - a. Stop engine and open all draincocks until brake system air pressure is vented.
 - b. Close all draincocks.

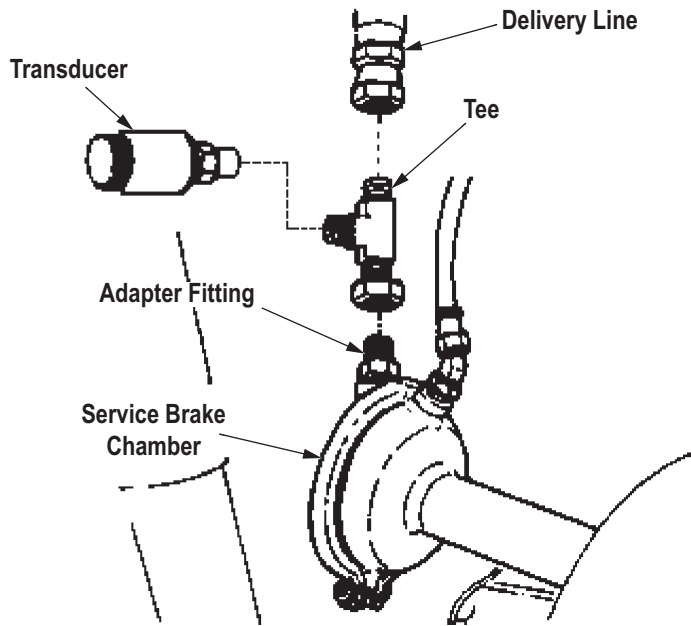

Figure 4. Rear Service Brake Chamber.

- c. Disconnect delivery line from right forward-rear rear service brake chamber adapter fitting (Volume 3, WP 0434). Refer to point to point schematics.
- d. Disconnect pressure gauge and tee from vehicle and return air line to original condition.
- e. Move tee to between disconnected service brake chamber and delivery line.
- f. Verify pressure gauge is connected to tee.
- g. Assistant starts engine and runs to build air supply to normal operating pressure.

INSUFFICIENT BRAKES (VEHICLE STOPPING DISTANCE TOO LONG, NO APPARENT AIR SYSTEM FAILURE WITH GAUGES AT NORMAL OPERATING PRESSURE, WARNING BUZZER NOT SOUNDING) - Continued

NOTE

Air pressure to service brake chambers must compare with reading on primary air pressure gauge. Air pressure to spring and service brake chambers must compare with reading on secondary air pressure gauge.

- h. Assistant fully applies and holds service brakes while comparing pressure gauge reading to instrument panel primary air pressure gauge reading.
- i. Pressure gauge should read 90 to 130 psi.
- j. Both readings should be similar.

CONDITION/INDICATION

IS THERE PROPER AIR PRESSURE AT THE RIGHT FORWARD-REAR REAR SERVICE BRAKE CHAMBER?

DECISION

NO - Go to Step (9).
YES - Go to Step (6).

INSUFFICIENT BRAKES (VEHICLE STOPPING DISTANCE TOO LONG, NO APPARENT AIR SYSTEM FAILURE WITH GAUGES AT NORMAL OPERATING PRESSURE, WARNING BUZZER NOT SOUNDING) - Continued

STEP

6. IS THERE PROPER AIR PRESSURE AT THE LEFT FORWARD-REAR REAR SERVICE BRAKE CHAMBER?
- a. Stop engine and open all draincocks until brake system air pressure is vented.
 - b. Close all draincocks.

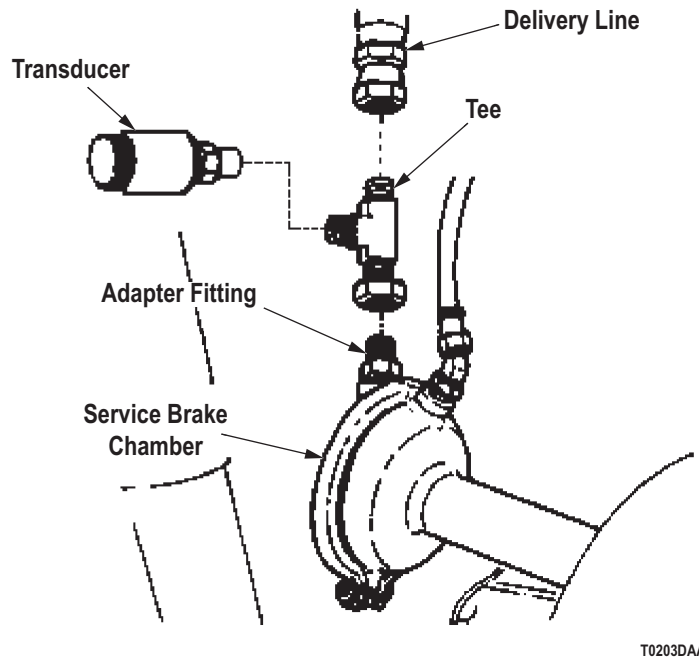

Figure 5. Rear Service Brake Chamber.

- c. Disconnect delivery line from left forward-rear rear service brake chamber adapter fitting (Volume 3, WP 0434). Refer to point to point schematics.
- d. Disconnect pressure gauge and tee from vehicle and return air line to original condition.
- e. Move tee to between disconnected service brake chamber and delivery line.
- f. Verify pressure gauge is connected to tee.
- g. Assistant starts engine and runs to build air supply to normal operating pressure.

INSUFFICIENT BRAKES (VEHICLE STOPPING DISTANCE TOO LONG, NO APPARENT AIR SYSTEM FAILURE WITH GAUGES AT NORMAL OPERATING PRESSURE, WARNING BUZZER NOT SOUNDING) - Continued

NOTE

Air pressure to service brake chambers must compare with reading on primary air pressure gauge. Air pressure to spring and service brake chambers must compare with reading on secondary air pressure gauge.

- h. Assistant fully applies and holds service brakes while comparing pressure gauge reading to instrument panel primary air pressure gauge reading.
- i. Pressure gauge should read 90 to 130 psi.
- j. Both readings should be similar.

CONDITION/INDICATION

IS THERE PROPER AIR PRESSURE AT THE LEFT FORWARD-REAR REAR SERVICE BRAKE CHAMBER?

DECISION

- NO - Go to Step (9).
- YES - Go to Step (7).

INSUFFICIENT BRAKES (VEHICLE STOPPING DISTANCE TOO LONG, NO APPARENT AIR SYSTEM FAILURE WITH GAUGES AT NORMAL OPERATING PRESSURE, WARNING BUZZER NOT SOUNDING) - Continued

STEP

7. IS THERE PROPER AIR PRESSURE AT THE RIGHT REAR-FORWARD REAR SERVICE BRAKE CHAMBER?
- Stop engine and open all draincocks until brake system air pressure is vented.
 - Close all draincocks.

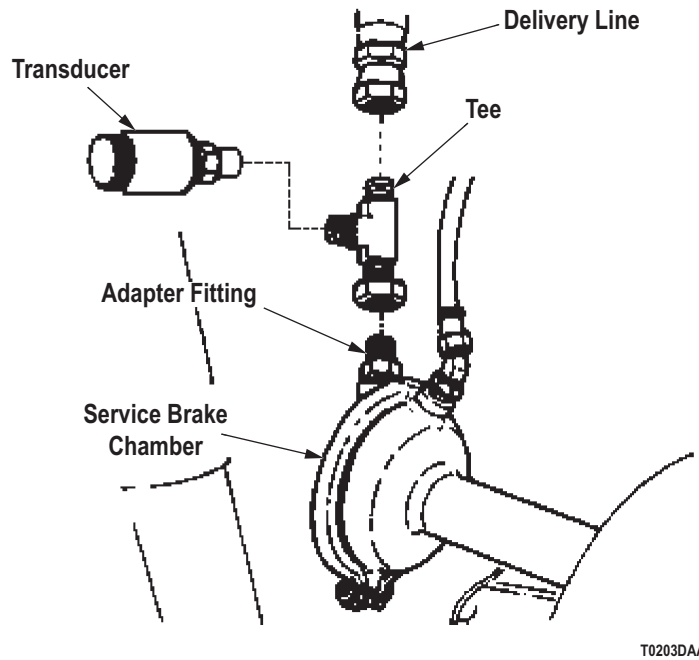

T0203DAA

Figure 6. Rear Service Brake Chamber.

- Disconnect delivery line from right rear-forward rear service brake chamber adapter fitting (Volume 3, WP 0434). Refer to point to point schematics.
- Disconnect pressure gauge and tee from vehicle and return air line to original condition.
- Move tee to between disconnected service brake chamber and delivery line.
- Verify pressure gauge is connected to tee.
- Assistant starts engine and runs to build air supply to normal operating pressure.

INSUFFICIENT BRAKES (VEHICLE STOPPING DISTANCE TOO LONG, NO APPARENT AIR SYSTEM FAILURE WITH GAUGES AT NORMAL OPERATING PRESSURE, WARNING BUZZER NOT SOUNDING) - Continued

NOTE

Air pressure to service brake chambers must compare with reading on primary air pressure gauge. Air pressure to spring and service brake chambers must compare with reading on secondary air pressure gauge.

- h. Assistant fully applies and holds service brakes while comparing pressure gauge reading to instrument panel primary air pressure gauge reading.
- i. Pressure gauge should read 90 to 130 psi.
- j. Both readings should be similar.

CONDITION/INDICATION

IS THERE PROPER AIR PRESSURE AT THE RIGHT REAR-REAR FORWARD SERVICE BRAKE CHAMBER?

DECISION

NO - Go to Step (24).
YES - Go to Step (8).

INSUFFICIENT BRAKES (VEHICLE STOPPING DISTANCE TOO LONG, NO APPARENT AIR SYSTEM FAILURE WITH GAUGES AT NORMAL OPERATING PRESSURE, WARNING BUZZER NOT SOUNDING) - Continued

STEP

8. IS THERE PROPER AIR PRESSURE AT THE LEFT REAR-FORWARD REAR SERVICE BRAKE CHAMBER?
- Stop engine and open all draincocks until brake system air pressure is vented.
 - Close all draincocks.

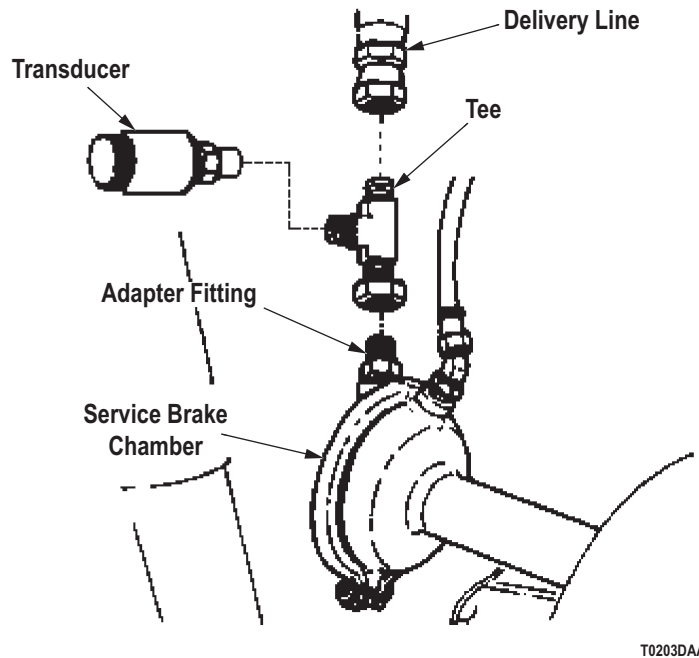

Figure 7. Rear Service Brake Chamber.

- Disconnect delivery line from left rear-forward rear service brake chamber adapter fitting (Volume 3, WP 0434). Refer to point to point schematics.
- Disconnect pressure gauge and tee from vehicle and return air line to original condition.
- Move tee to between disconnected service brake chamber and delivery line.
- Verify pressure gauge is connected to tee.
- Assistant starts engine and runs to build air supply to normal operating pressure.

INSUFFICIENT BRAKES (VEHICLE STOPPING DISTANCE TOO LONG, NO APPARENT AIR SYSTEM FAILURE WITH GAUGES AT NORMAL OPERATING PRESSURE, WARNING BUZZER NOT SOUNDING) - Continued

NOTE

Air pressure to service brake chambers must compare with reading on primary air pressure gauge. Air pressure to spring and service brake chambers must compare with reading on secondary air pressure gauge.

- h. Assistant fully applies and holds service brakes while comparing pressure gauge reading to instrument panel primary air pressure gauge reading.
- i. Pressure gauge should read 90 to 130 psi.
- j. Both readings should be similar.

CONDITION/INDICATION

IS THERE PROPER AIR PRESSURE AT THE LEFT REAR-REAR FORWARD SERVICE BRAKE CHAMBER?

DECISION

- NO - Go to Step (24).
- YES - Go to Step (11).

INSUFFICIENT BRAKES (VEHICLE STOPPING DISTANCE TOO LONG, NO APPARENT AIR SYSTEM FAILURE WITH GAUGES AT NORMAL OPERATING PRESSURE, WARNING BUZZER NOT SOUNDING) - Continued

STEP

9. IS THERE PROPER AIR PRESSURE AT THE RIGHT REAR-REAR FORWARD SERVICE BRAKE CHAMBER?
- Stop engine and open all draincocks until brake system air pressure is vented.
 - Close all draincocks.

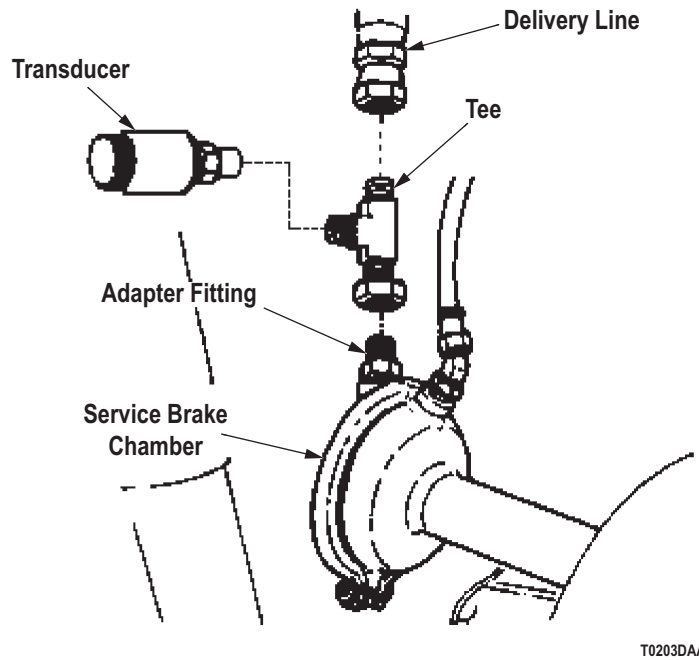

T0203DAA

Figure 8. Rear Service Brake Chamber.

- Disconnect delivery line from right rear-rear forward service brake chamber adapter fitting (Volume 3, WP 0434). Refer to point to point schematics.
- Disconnect pressure gauge and tee from vehicle and return air line to original condition.
- Move tee to between disconnected service brake chamber and delivery line.
- Verify pressure gauge is connected to tee.
- Assistant starts engine and runs to build air supply to normal operating pressure.

INSUFFICIENT BRAKES (VEHICLE STOPPING DISTANCE TOO LONG, NO APPARENT AIR SYSTEM FAILURE WITH GAUGES AT NORMAL OPERATING PRESSURE, WARNING BUZZER NOT SOUNDING) - Continued

NOTE

Air pressure to service brake chambers must compare with reading on primary air pressure gauge. Air pressure to spring and service brake chambers must compare with reading on secondary air pressure gauge.

- h. Assistant fully applies and holds service brakes while comparing pressure gauge reading to instrument panel primary air pressure gauge reading.
- i. Pressure gauge should read 90 to 130 psi.
- j. Both readings should be similar.

CONDITION/INDICATION

IS THERE PROPER AIR PRESSURE AT THE RIGHT REAR-REAR FORWARD SERVICE BRAKE CHAMBER?

DECISION

NO - Go to Step (25).
YES - Go to Step (10).

INSUFFICIENT BRAKES (VEHICLE STOPPING DISTANCE TOO LONG, NO APPARENT AIR SYSTEM FAILURE WITH GAUGES AT NORMAL OPERATING PRESSURE, WARNING BUZZER NOT SOUNDING) - Continued

STEP

10. IS THERE PROPER AIR PRESSURE AT THE LEFT REAR-REAR FORWARD SERVICE BRAKE CHAMBER?
 - a. Stop engine and open all draincocks until brake system air pressure is vented.
 - b. Close all draincocks.

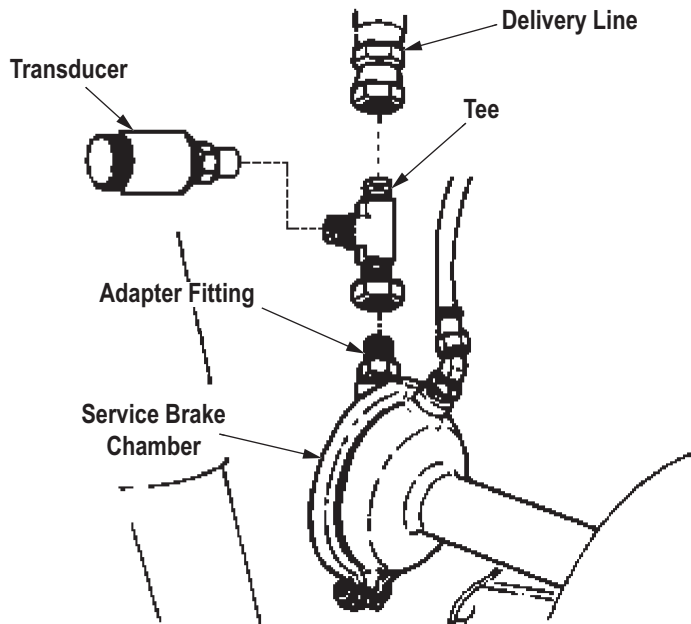

T0203DAA

Figure 9. Rear Service Brake Chamber.

- c. Disconnect delivery line from left rear-rear forward service brake chamber adapter fitting (Volume 3, WP 0434). Refer to point to point schematics.
- d. Disconnect pressure gauge and tee from vehicle and return air line to original condition.
- e. Move tee to between disconnected service brake chamber and delivery line.
- f. Verify pressure gauge is connected to tee.
- g. Assistant starts engine and runs to build air supply to normal operating pressure.

INSUFFICIENT BRAKES (VEHICLE STOPPING DISTANCE TOO LONG, NO APPARENT AIR SYSTEM FAILURE WITH GAUGES AT NORMAL OPERATING PRESSURE, WARNING BUZZER NOT SOUNDING) - Continued

NOTE

Air pressure to service brake chambers must compare with reading on primary air pressure gauge. Air pressure to spring and service brake chambers must compare with reading on secondary air pressure gauge.

- h. Assistant fully applies and holds service brakes while comparing pressure gauge reading to instrument panel primary air pressure gauge reading.
- i. Pressure gauge should read 90 to 130 psi.
- j. Both readings should be similar.

CONDITION/INDICATION

IS THERE PROPER AIR PRESSURE AT THE LEFT REAR-REAR FORWARD SERVICE BRAKE CHAMBER?

DECISION

- NO - Go to Step (25).
- YES - Go to Step (23).

INSUFFICIENT BRAKES (VEHICLE STOPPING DISTANCE TOO LONG, NO APPARENT AIR SYSTEM FAILURE WITH GAUGES AT NORMAL OPERATING PRESSURE, WARNING BUZZER NOT SOUNDING) - Continued

STEP

11. IS THERE PROPER AIR PRESSURE AT THE RIGHT FORWARD-REAR FORWARD SPRING AND SERVICE BRAKE CHAMBER?
- Stop engine and open all draincocks until brake system air pressure is vented.
 - Close all draincocks.

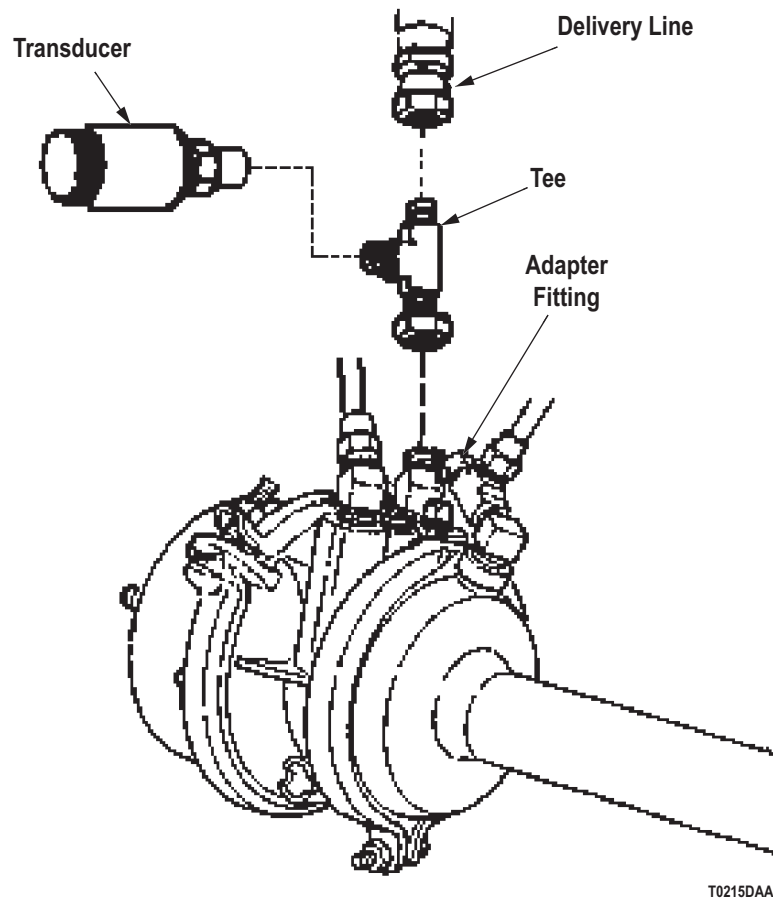

Figure 10. Rear Service And Spring Brake Chamber.

INSUFFICIENT BRAKES (VEHICLE STOPPING DISTANCE TOO LONG, NO APPARENT AIR SYSTEM FAILURE WITH GAUGES AT NORMAL OPERATING PRESSURE, WARNING BUZZER NOT SOUNDING) - Continued

- c. Disconnect delivery line from right forward-rear forward spring and service brake chamber adapter fitting (Volume 3, WP 0435). Refer to point to point schematics.
- d. Disconnect pressure gauge and tee from vehicle and return air line to original condition.
- e. Move tee to between disconnected service brake chamber and delivery line.
- f. Verify pressure gauge is connected to tee.
- g. Assistant starts engine and runs to build air supply to normal operating pressure.

NOTE

Air pressure to service brake chambers must compare with reading on primary air pressure gauge. Air pressure to spring and service brake chambers must compare with reading on secondary air pressure gauge.

- h. Assistant fully applies and holds service brakes while comparing pressure gauge reading to instrument panel secondary air pressure gauge reading.
- i. Pressure gauge should read 90 to 130 psi.
- j. Both readings should be similar.

CONDITION/INDICATION

IS THERE PROPER AIR PRESSURE AT THE RIGHT FORWARD-REAR FORWARD SPRING AND SERVICE BRAKE CHAMBER?

DECISION

NO - Go to Step (15).
YES - Go to Step (12).

INSUFFICIENT BRAKES (VEHICLE STOPPING DISTANCE TOO LONG, NO APPARENT AIR SYSTEM FAILURE WITH GAUGES AT NORMAL OPERATING PRESSURE, WARNING BUZZER NOT SOUNDING) - Continued

STEP

12. IS THERE PROPER AIR PRESSURE AT THE LEFT FORWARD-REAR FORWARD SPRING AND SERVICE BRAKE CHAMBER?
- Stop engine and open all draincocks until brake system air pressure is vented.
 - Close all draincocks.

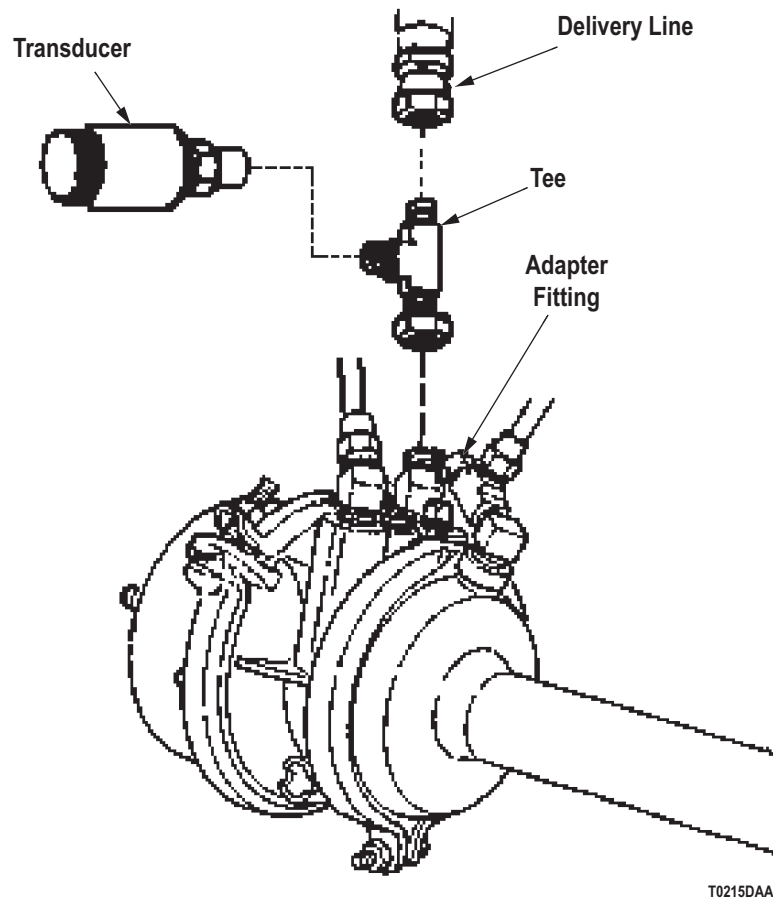

Figure 11. Rear Service And Spring Brake Chamber.

INSUFFICIENT BRAKES (VEHICLE STOPPING DISTANCE TOO LONG, NO APPARENT AIR SYSTEM FAILURE WITH GAUGES AT NORMAL OPERATING PRESSURE, WARNING BUZZER NOT SOUNDING) - Continued

- c. Disconnect delivery line from left forward-rear forward spring and service brake chamber adapter fitting (Volume 3, WP 0435). Refer to point to point schematics.
- d. Disconnect pressure gauge and tee from vehicle and return air line to original condition.
- e. Move tee to between disconnected service brake chamber and delivery line.
- f. Verify pressure gauge is connected to tee.
- g. Assistant starts engine and runs to build air supply to normal operating pressure.

NOTE

Air pressure to service brake chambers must compare with reading on primary air pressure gauge. Air pressure to spring and service brake chambers must compare with reading on secondary air pressure gauge.

- h. Assistant fully applies and holds service brakes while comparing pressure gauge reading to instrument panel secondary air pressure gauge reading.
- i. Pressure gauge should read 90 to 130 psi.
- j. Both readings should be similar.

CONDITION/INDICATION

IS THERE PROPER AIR PRESSURE AT THE LEFT FORWARD-REAR FORWARD SPRING AND SERVICE BRAKE CHAMBER?

DECISION

NO - Go to Step (15).
YES - Go to Step (13).

INSUFFICIENT BRAKES (VEHICLE STOPPING DISTANCE TOO LONG, NO APPARENT AIR SYSTEM FAILURE WITH GAUGES AT NORMAL OPERATING PRESSURE, WARNING BUZZER NOT SOUNDING) - Continued

STEP

13. IS THERE PROPER AIR PRESSURE AT THE RIGHT REAR-REAR REAR SPRING AND SERVICE BRAKE CHAMBER?
- Stop engine and open all draincocks until brake system air pressure is vented.
 - Close all draincocks.

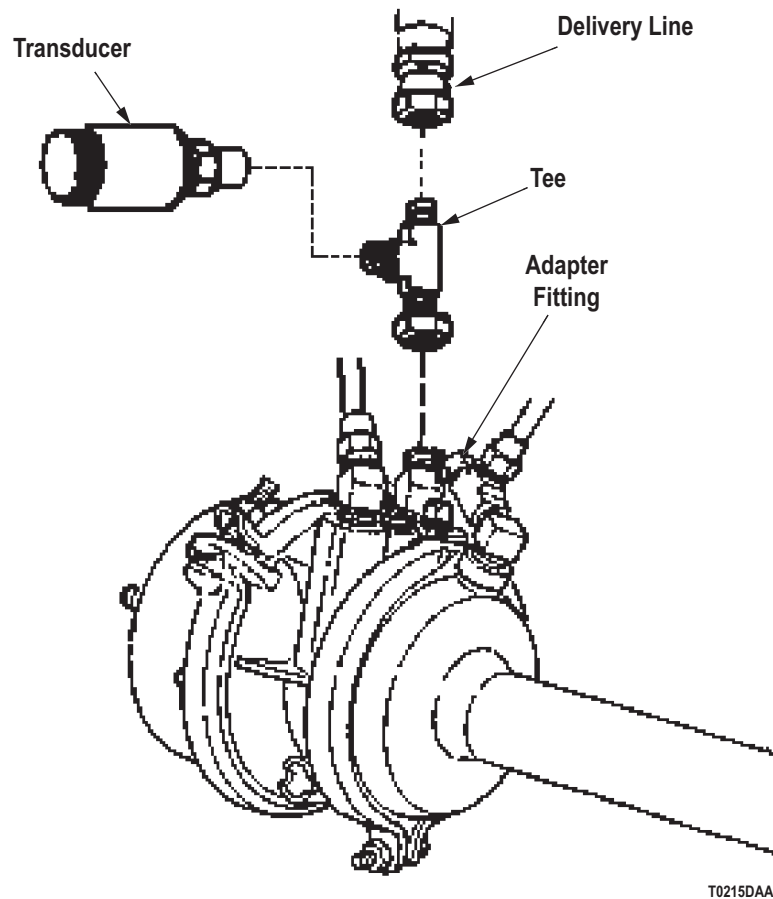

Figure 12. Rear Service And Spring Brake Chamber.

INSUFFICIENT BRAKES (VEHICLE STOPPING DISTANCE TOO LONG, NO APPARENT AIR SYSTEM FAILURE WITH GAUGES AT NORMAL OPERATING PRESSURE, WARNING BUZZER NOT SOUNDING) - Continued

- c. Disconnect delivery line from right rear-rear rear spring and service brake chamber adapter fitting (Volume 3, WP 0435). Refer to point to point schematics.
- d. Disconnect pressure gauge and tee from vehicle and return air line to original condition.
- e. Move tee to between disconnected service brake chamber and delivery line.
- f. Verify pressure gauge is connected to tee.
- g. Assistant starts engine and runs to build air supply to normal operating pressure.

NOTE

Air pressure to service brake chambers must compare with reading on primary air pressure gauge. Air pressure to spring and service brake chambers must compare with reading on secondary air pressure gauge.

- h. Assistant fully applies and holds service brakes while comparing pressure gauge reading to instrument panel secondary air pressure gauge reading.
- i. Pressure gauge should read 90 to 130 psi.
- j. Both readings should be similar.

CONDITION/INDICATION

IS THERE PROPER AIR PRESSURE AT THE RIGHT REAR-REAR REAR SPRING AND SERVICE BRAKE CHAMBER?

DECISION

NO - Go to Step (27).
YES - Go to Step (14).

INSUFFICIENT BRAKES (VEHICLE STOPPING DISTANCE TOO LONG, NO APPARENT AIR SYSTEM FAILURE WITH GAUGES AT NORMAL OPERATING PRESSURE, WARNING BUZZER NOT SOUNDING) - Continued

STEP

14. IS THERE PROPER AIR PRESSURE AT THE LEFT REAR-REAR REAR SPRING AND SERVICE BRAKE CHAMBER?
- Stop engine and open all draincocks until brake system air pressure is vented.
 - Close all draincocks.

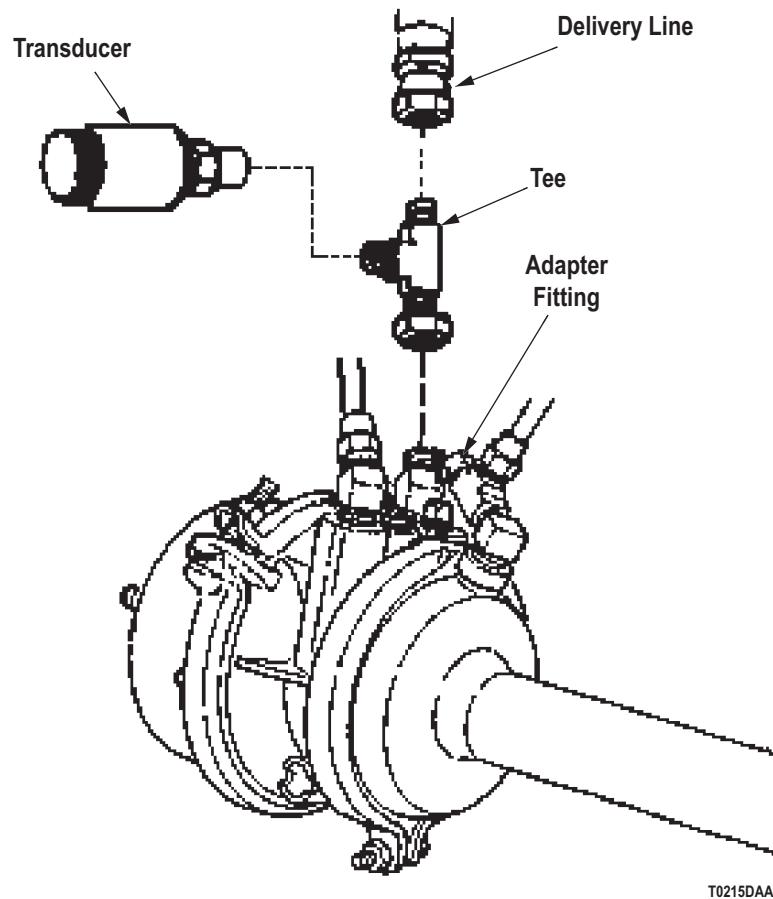

Figure 13. Rear Service And Spring Brake Chamber.

INSUFFICIENT BRAKES (VEHICLE STOPPING DISTANCE TOO LONG, NO APPARENT AIR SYSTEM FAILURE WITH GAUGES AT NORMAL OPERATING PRESSURE, WARNING BUZZER NOT SOUNDING) - Continued

- c. Disconnect delivery line from left rear-rear rear spring and service brake chamber adapter fitting (Volume 3, WP 0435). Refer to point to point schematics.
- d. Disconnect pressure gauge and tee from vehicle and return air line to original condition.
- e. Move tee to between disconnected service brake chamber and delivery line.
- f. Verify pressure gauge is connected to tee.
- g. Assistant starts engine and runs to build air supply to normal operating pressure.

NOTE

Air pressure to service brake chambers must compare with reading on primary air pressure gauge. Air pressure to spring and service brake chambers must compare with reading on secondary air pressure gauge.

- h. Assistant fully applies and holds service brakes while comparing pressure gauge reading to instrument panel secondary air pressure gauge reading.
- i. Pressure gauge should read 90 to 130 psi.
- j. Both readings should be similar.

CONDITION/INDICATION

IS THERE PROPER AIR PRESSURE AT THE LEFT REAR-REAR REAR SPRING AND SERVICE BRAKE CHAMBER?

DECISION

NO - Go to Step (27).
YES - Go to Step (29).

INSUFFICIENT BRAKES (VEHICLE STOPPING DISTANCE TOO LONG, NO APPARENT AIR SYSTEM FAILURE WITH GAUGES AT NORMAL OPERATING PRESSURE, WARNING BUZZER NOT SOUNDING) - Continued

STEP

15. IS THERE PROPER AIR PRESSURE AT THE RIGHT REAR-REAR REAR SPRING AND SERVICE BRAKE CHAMBER?
- Stop engine and open all draincocks until brake system air pressure is vented.
 - Close all draincocks.

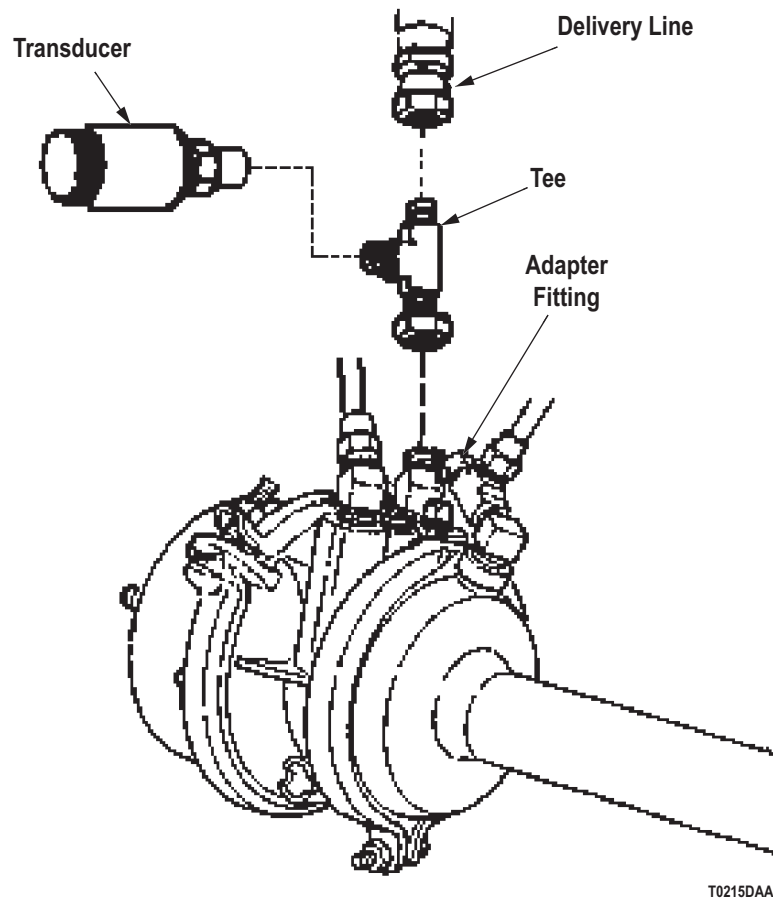

Figure 14. Rear Service And Spring Brake Chamber.

INSUFFICIENT BRAKES (VEHICLE STOPPING DISTANCE TOO LONG, NO APPARENT AIR SYSTEM FAILURE WITH GAUGES AT NORMAL OPERATING PRESSURE, WARNING BUZZER NOT SOUNDING) - Continued

- c. Disconnect delivery line from right rear-rear rear spring and service brake chamber adapter fitting (Volume 3, WP 0435). Refer to point to point schematics.
- d. Disconnect pressure gauge and tee from vehicle and return air line to original condition.
- e. Move tee to between disconnected service brake chamber and delivery line.
- f. Verify pressure gauge is connected to tee.
- g. Assistant starts engine and runs to build air supply to normal operating pressure.

NOTE

Air pressure to service brake chambers must compare with reading on primary air pressure gauge. Air pressure to spring and service brake chambers must compare with reading on secondary air pressure gauge.

- h. Assistant fully applies and holds service brakes while comparing pressure gauge reading to instrument panel secondary air pressure gauge reading.
- i. Pressure gauge should read 90 to 130 psi.
- j. Both readings should be similar.

CONDITION/INDICATION

IS THERE PROPER AIR PRESSURE AT THE RIGHT REAR-REAR REAR SPRING AND SERVICE BRAKE CHAMBER?

DECISION

NO - Go to Step (28).
YES - Go to Step (16).

INSUFFICIENT BRAKES (VEHICLE STOPPING DISTANCE TOO LONG, NO APPARENT AIR SYSTEM FAILURE WITH GAUGES AT NORMAL OPERATING PRESSURE, WARNING BUZZER NOT SOUNDING) - Continued

STEP

16. IS THERE PROPER AIR PRESSURE AT THE LEFT REAR-REAR REAR SPRING AND SERVICE BRAKE CHAMBER?
- Stop engine and open all draincocks until brake system air pressure is vented.
 - Close all draincocks.

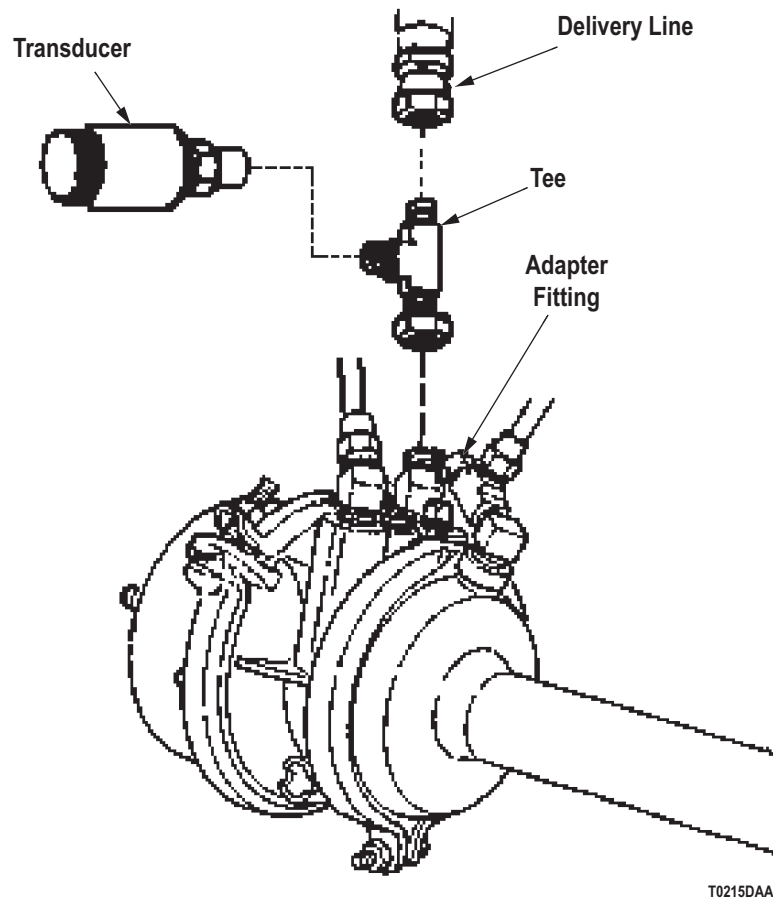

Figure 15. Rear Service And Spring Brake Chamber.

INSUFFICIENT BRAKES (VEHICLE STOPPING DISTANCE TOO LONG, NO APPARENT AIR SYSTEM FAILURE WITH GAUGES AT NORMAL OPERATING PRESSURE, WARNING BUZZER NOT SOUNDING) - Continued

- c. Disconnect delivery line from left rear-rear rear spring and service brake chamber adapter fitting (Volume 3, WP 0435). Refer to point to point schematics.
- d. Disconnect pressure gauge and tee from vehicle and return air line to original condition.
- e. Move tee to between disconnected service brake chamber and delivery line.
- f. Verify pressure gauge is connected to tee.
- g. Assistant starts engine and runs to build air supply to normal operating pressure.

NOTE

Air pressure to service brake chambers must compare with reading on primary air pressure gauge. Air pressure to spring and service brake chambers must compare with reading on secondary air pressure gauge.

- h. Assistant fully applies and holds service brakes while comparing pressure gauge reading to instrument panel secondary air pressure gauge reading.
- i. Pressure gauge should read 90 to 130 psi.
- j. Both readings should be similar.

CONDITION/INDICATION

IS THERE PROPER AIR PRESSURE AT THE LEFT REAR-REAR REAR SPRING AND SERVICE BRAKE CHAMBER?

DECISION

NO - Go to Step (28).
YES - Go to Step (26).

INSUFFICIENT BRAKES (VEHICLE STOPPING DISTANCE TOO LONG, NO APPARENT AIR SYSTEM FAILURE WITH GAUGES AT NORMAL OPERATING PRESSURE, WARNING BUZZER NOT SOUNDING) - Continued

STEP

17. DOES THE LIMITING VALVE OPERATE PROPERLY?

- a. Stop engine and open all draincocks until brake system air pressure is vented.
- b. Close all draincocks.
- c. Disconnect pressure gauge and tee from vehicle and return air line to original condition.
- d. Assistant starts engine and runs to build air supply to normal operating pressure.

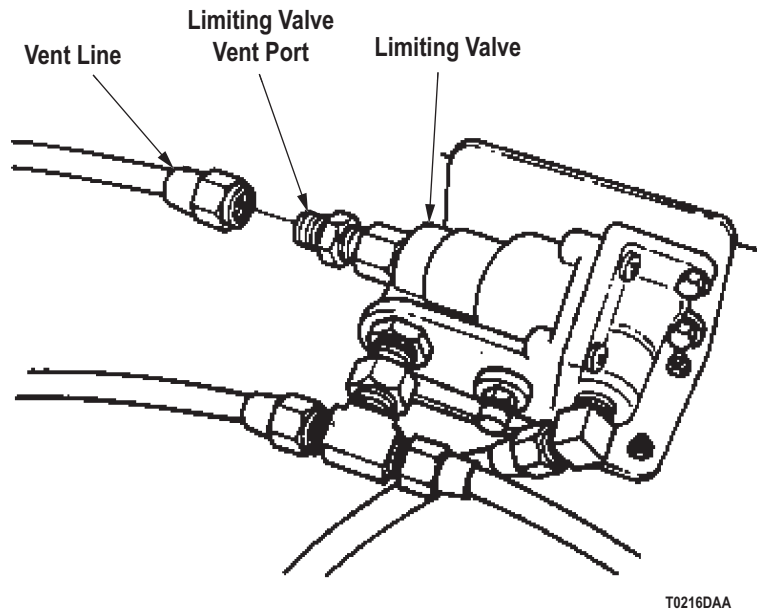
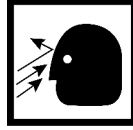

Figure 16. Limiting Valve.

- e. Disconnect vent line from limiting valve vent port (Volume 3, WP 0439). Refer to point to point schematics.

INSUFFICIENT BRAKES (VEHICLE STOPPING DISTANCE TOO LONG, NO APPARENT AIR SYSTEM FAILURE WITH GAUGES AT NORMAL OPERATING PRESSURE, WARNING BUZZER NOT SOUNDING) - Continued

WARNING



Do not look in service chamber vent port when performing test. Failure to comply may result in injury or death to personnel.

- f. Assistant fully applies and holds service brake pedal.
- g. Feel for escaping air pressure at limiting valve vent port.
- h. If air is felt escaping, limiting valve vent is not operating properly.

CONDITION/INDICATION

DOES THE LIMITING VALVE OPERATE PROPERLY?

DECISION

NO - Replace defective limiting valve (Volume 3, WP 0439). Go to Step (30) to verify problem is solved.
YES - Go to Step (18).

INSUFFICIENT BRAKES (VEHICLE STOPPING DISTANCE TOO LONG, NO APPARENT AIR SYSTEM FAILURE WITH GAUGES AT NORMAL OPERATING PRESSURE, WARNING BUZZER NOT SOUNDING) - Continued

STEP

18. IS LIMITING VALVE DELIVERING PROPER AIR PRESSURE?

- a. Stop engine and open all draincocks until brake system air pressure is vented.
- b. Close all draincocks.
- c. Return vent line to original condition.

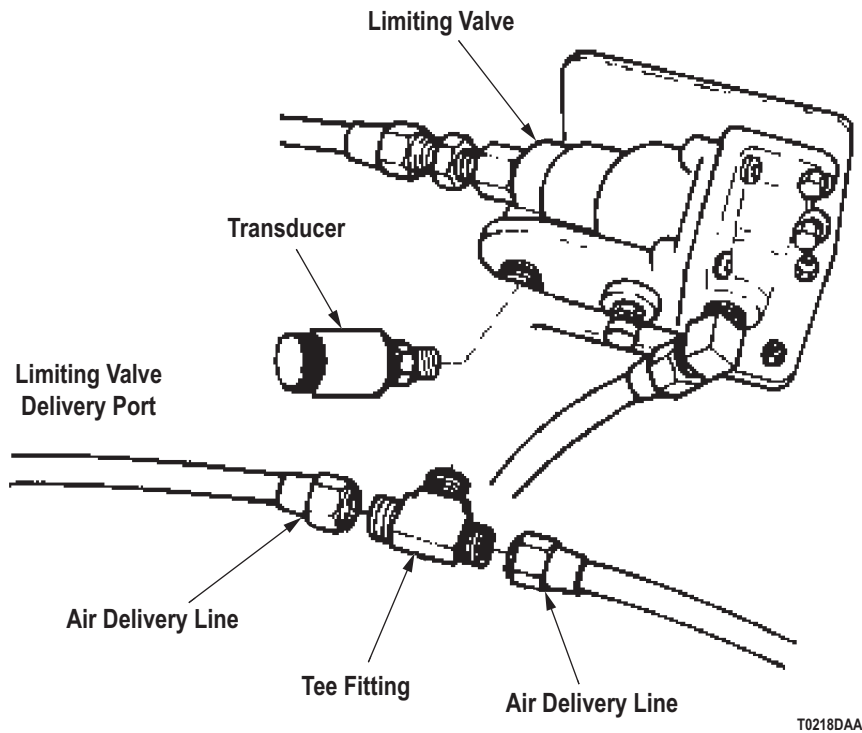

Figure 17. Limiting Valve.

INSUFFICIENT BRAKES (VEHICLE STOPPING DISTANCE TOO LONG, NO APPARENT AIR SYSTEM FAILURE WITH GAUGES AT NORMAL OPERATING PRESSURE, WARNING BUZZER NOT SOUNDING) - Continued

- d. Disconnect delivery lines from tee fitting at limiting valve (Volume 3, WP 0439). Refer to point to point schematics.
- e. Disconnect tee fitting from limiting valve.
- f. Connect pressure gauge to disconnected limiting valve delivery port.
- g. Assistant starts engine and runs to build air supply to normal operating pressure.
- h. Assistant fully applies and holds service brakes.
- i. Monitor air pressure on pressure gauge.
- j. Measurement can be taken after pressure reaches 90 psi, or after 5 minutes, whichever occurs first.
- k. Pressure gauge should read 90 to 130 psi.

CONDITION/INDICATION

IS LIMITING VALVE DELIVERING PROPER AIR PRESSURE?

DECISION

NO - Go to Step (19).

YES - Replace damaged air lines from limiting valve to front brake chambers (Volume 5, WP 0805). Go to Step (30) to verify problem is solved.

INSUFFICIENT BRAKES (VEHICLE STOPPING DISTANCE TOO LONG, NO APPARENT AIR SYSTEM FAILURE WITH GAUGES AT NORMAL OPERATING PRESSURE, WARNING BUZZER NOT SOUNDING) - Continued

STEP

19. IS THERE PROPER AIR SUPPLY PRESSURE AT LIMITING VALVE?

- a. Stop engine and open all draincocks until brake system air pressure is vented.
- b. Close all draincocks.
- c. Disconnect pressure gauge from vehicle and return tee fitting and air lines to original condition.

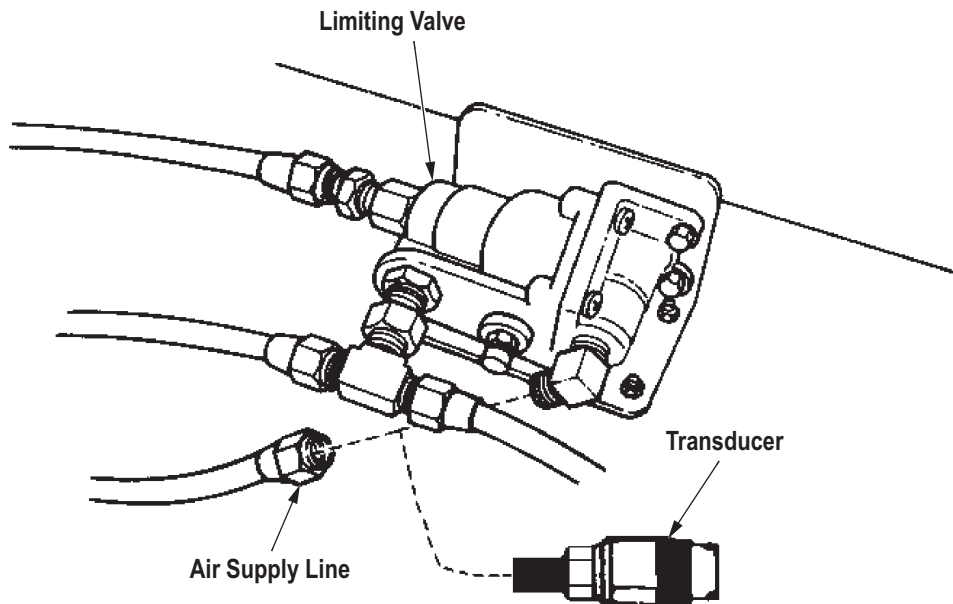

T0219DAA

Figure 18. Limiting Valve.

- d. Disconnect air supply line from limiting valve (Volume 3, WP 0439). Refer to point to point schematics.
- e. Connect pressure gauge to o disconnected limiting valve air supply line.
- f. Assistant starts engine and runs to build air supply to normal operating pressure.
- g. Assistant fully applies and holds service brakes.
- h. Monitor air pressure on pressure gauge.
- i. Pressure gauge should read 90 to 130 psi.

CONDITION/INDICATION

IS THERE PROPER AIR SUPPLY PRESSURE AT LIMITING VALVE?

DECISION

NO - Go to Step (20).

YES - Replace defective limiting valve (Volume 3, WP 0439). Go to Step (30) to verify problem is solved.

INSUFFICIENT BRAKES (VEHICLE STOPPING DISTANCE TOO LONG, NO APPARENT AIR SYSTEM FAILURE WITH GAUGES AT NORMAL OPERATING PRESSURE, WARNING BUZZER NOT SOUNDING) - Continued

STEP

20. IS THERE A BLOCKAGE IN THE LIMITING VALVE AIR SUPPLY LINE?

- a. Stop engine and open all draincocks until brake system air pressure is vented.
- b. Close all draincocks.
- c. Disconnect pressure gauge from air supply line.

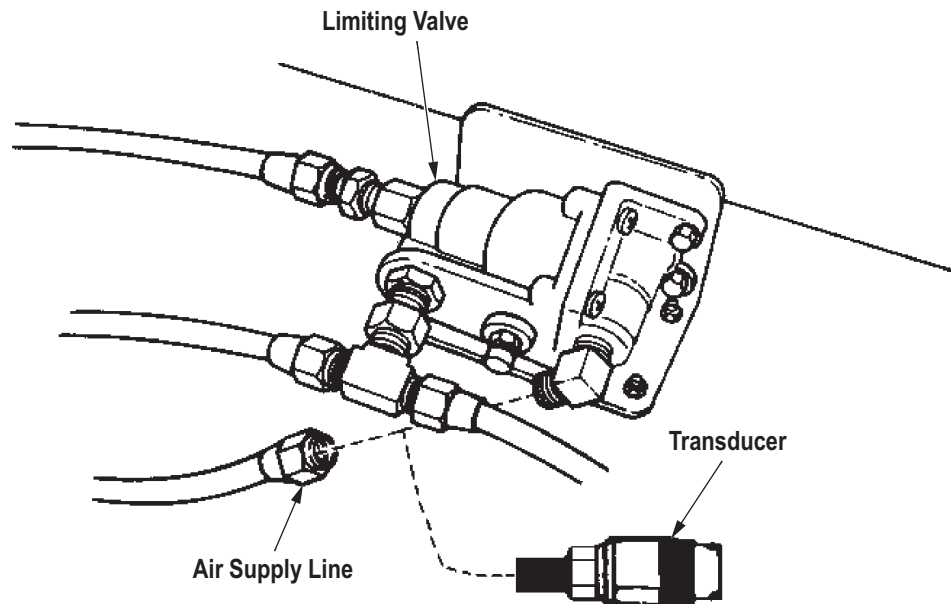

T0219DAA

Figure 19. Limiting Valve.

- d. Check air supply line for blockage.

CONDITION/INDICATION

IS THERE A BLOCKAGE IN THE LIMITING VALVE AIR SUPPLY LINE?

DECISION

NO - Go to Step (21).

YES - Repair or replace blocked air line (Volume 5, WP 0805). Go to Step (30) to verify problem is solved.

INSUFFICIENT BRAKES (VEHICLE STOPPING DISTANCE TOO LONG, NO APPARENT AIR SYSTEM FAILURE WITH GAUGES AT NORMAL OPERATING PRESSURE, WARNING BUZZER NOT SOUNDING) - Continued

STEP

21. IS PROPER AIR SUPPLY PRESSURE AT DOUBLE CHECK VALVE #1?

- a. Stop engine and open all draincocks until brake system air pressure is vented.
- b. Close all draincocks.
- c. Disconnect pressure gauge from vehicle and return air line to original condition.
- d. Direct assistant to keep foot off service brake pedal.

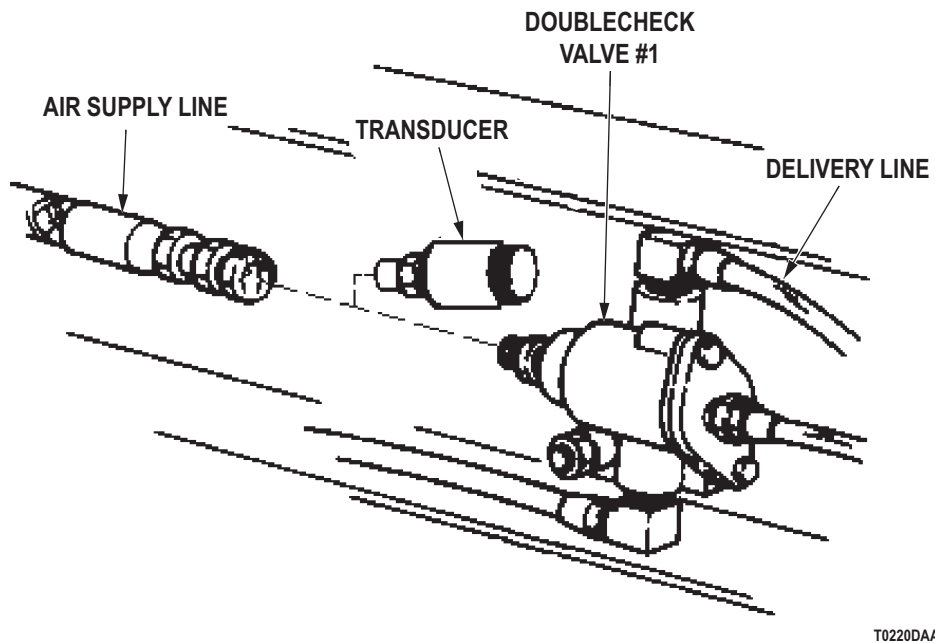

Figure 20. Double Check Valve #1.

INSUFFICIENT BRAKES (VEHICLE STOPPING DISTANCE TOO LONG, NO APPARENT AIR SYSTEM FAILURE WITH GAUGES AT NORMAL OPERATING PRESSURE, WARNING BUZZER NOT SOUNDING) - Continued

- e. Disconnect double check #1 valve air supply line (Volume 3, WP 0473). Refer to point to point schematics.
- f. Connect pressure gauge to disconnected air supply line.
- g. Assistant starts engine and runs to build air supply to normal operating pressure.
- h. Assistant fully applies and holds service brakes.
- i. Monitor air pressure on pressure gauge.
- j. Pressure gauge should read 90 to 130 psi.

CONDITION/INDICATION

IS PROPER AIR SUPPLY PRESSURE AT DOUBLE CHECK VALVE #1?

DECISION

NO - Go to Step (22).

YES - Replace double check valve #1 (Volume 3, WP 0473). Go to Step (30) to verify problem is solved.

INSUFFICIENT BRAKES (VEHICLE STOPPING DISTANCE TOO LONG, NO APPARENT AIR SYSTEM FAILURE WITH GAUGES AT NORMAL OPERATING PRESSURE, WARNING BUZZER NOT SOUNDING) - Continued

STEP

22. IS PROPER AIR PRESSURE AT SERVICE BRAKE PEDAL VALVE PRIMARY AIR SYSTEM DELIVERY PORT?

- a. Stop engine and open all draincocks until brake system air pressure is vented.
- b. Close all draincocks.

WARNING

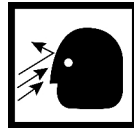

- Do not depress service brake pedal during removal of plug and/or installation of test gauge. Failure to comply may result in injury or death to personnel.
 - Remove correct plug only. Failure to comply may result in injury or death to personnel.
- c. Direct assistant to keep foot off service brake pedal.
 - d. Disconnect pressure gauge from vehicle and return air line to original condition.

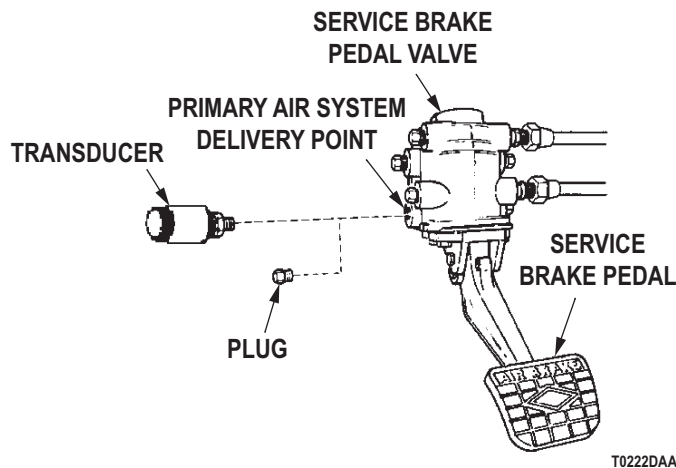

Figure 21. Service Brake Pedal Valve.

INSUFFICIENT BRAKES (VEHICLE STOPPING DISTANCE TOO LONG, NO APPARENT AIR SYSTEM FAILURE WITH GAUGES AT NORMAL OPERATING PRESSURE, WARNING BUZZER NOT SOUNDING) - Continued

- e. Remove plug from service brake pedal valve primary air system delivery port. Refer to point to point schematics.
- f. Connect pressure gauge to primary air system delivery port.
- g. Assistant starts engine and runs to build air supply to normal operating pressure.
- h. Assistant fully applies and holds service brakes.
- i. Monitor air pressure on pressure gauge.
- j. Pressure gauge should read 90 to 130 psi.

CONDITION/INDICATION

IS PROPER AIR PRESSURE AT SERVICE BRAKE PEDAL VALVE PRIMARY AIR SYSTEM DELIVERY PORT?

DECISION

NO - Replace defective service brake pedal valve (Volume 3, WP 0429), M936 (Volume 3, WP 0430). Go to Step (30) to verify problem is solved.

YES - Repair or replace blocked air line to double check valve #1 (Volume 5, WP 0805). Go to Step (30) to verify problem is solved.

INSUFFICIENT BRAKES (VEHICLE STOPPING DISTANCE TOO LONG, NO APPARENT AIR SYSTEM FAILURE WITH GAUGES AT NORMAL OPERATING PRESSURE, WARNING BUZZER NOT SOUNDING) - Continued

STEP

23. IS PROPER AIR PRESSURE AT PRIMARY RELAY VALVE?

- a. Stop engine and open all draincocks until brake system air pressure is vented.
- b. Close all draincocks.
- c. Disconnect pressure gauge from vehicle and return air line to original condition.

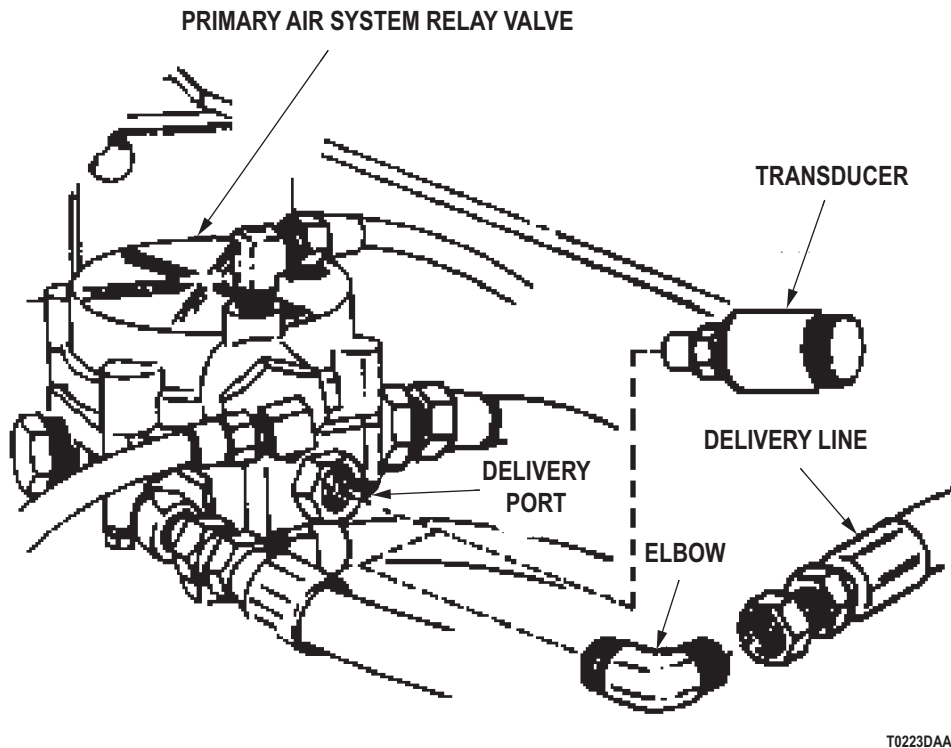

Figure 22. Primary Relay Valve Delivery Port.

INSUFFICIENT BRAKES (VEHICLE STOPPING DISTANCE TOO LONG, NO APPARENT AIR SYSTEM FAILURE WITH GAUGES AT NORMAL OPERATING PRESSURE, WARNING BUZZER NOT SOUNDING) - Continued

- d. Disconnect air line from elbow at primary relay valve delivery port (Volume 3, WP 0458). Refer to point to point schematics.
- e. Remove elbow from primary relay valve delivery port.
- f. Connect pressure gauge to disconnected relay valve delivery port.
- g. Assistant starts engine and runs to build air supply to normal operating pressure.
- h. Assistant fully applies and holds service brakes.
- i. Monitor air pressure on pressure gauge.
- j. Pressure gauge should read 90 to 130 psi.

CONDITION/INDICATION

IS PROPER AIR PRESSURE AT PRIMARY RELAY VALVE?

DECISION

NO - Go to Step (25).

YES - Replace damaged air lines from primary relay valve to rear brake chambers (Volume 5, WP 0805). Go to Step (30) to verify problem is solved.

INSUFFICIENT BRAKES (VEHICLE STOPPING DISTANCE TOO LONG, NO APPARENT AIR SYSTEM FAILURE WITH GAUGES AT NORMAL OPERATING PRESSURE, WARNING BUZZER NOT SOUNDING) - Continued

STEP

24. IS PROPER AIR PRESSURE AT PRIMARY RELAY VALVE?

- a. Stop engine and open all draincocks until brake system air pressure is vented.
- b. Close all draincocks.
- c. Disconnect pressure gauge from vehicle and return air line to original condition.

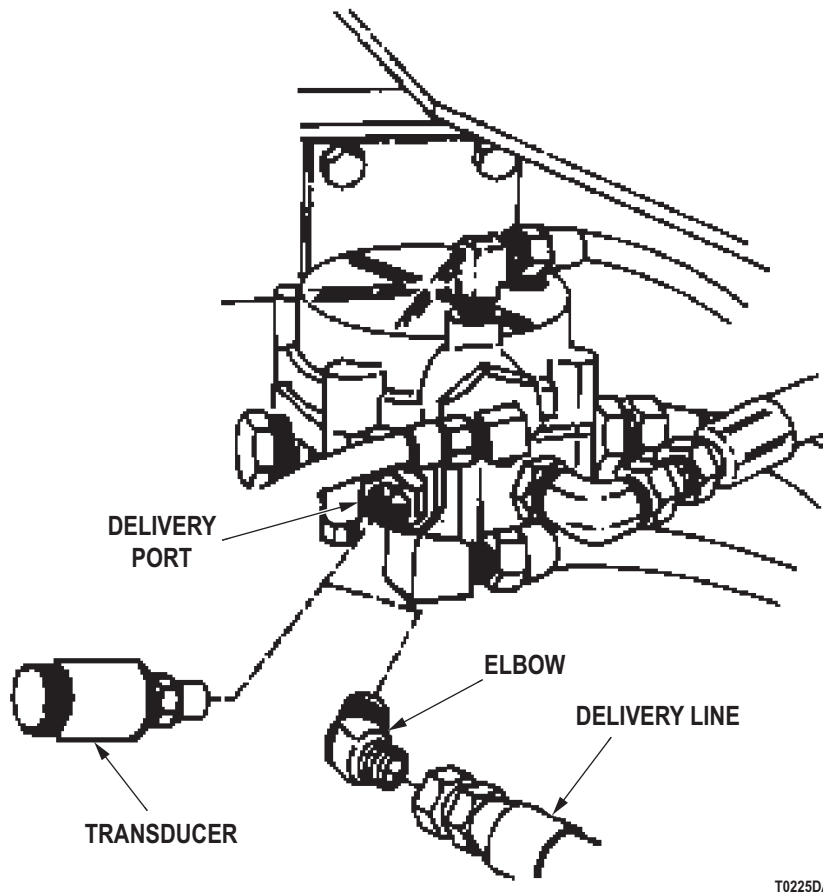

Figure 23. Primary Relay Valve Delivery Port.

INSUFFICIENT BRAKES (VEHICLE STOPPING DISTANCE TOO LONG, NO APPARENT AIR SYSTEM FAILURE WITH GAUGES AT NORMAL OPERATING PRESSURE, WARNING BUZZER NOT SOUNDING) - Continued

- d. Disconnect air line from elbow at primary relay valve delivery port (Volume 3, WP 0458). Refer to point to point schematics.
- e. Remove elbow from primary relay valve delivery port.
- f. Connect pressure gauge to disconnected relay valve delivery port.
- g. Assistant starts engine and runs to build air supply to normal operating pressure.
- h. Assistant fully applies and holds service brakes.
- i. Monitor air pressure on pressure gauge.
- j. Pressure gauge should read 90 to 130 psi.

CONDITION/INDICATION

IS PROPER AIR PRESSURE AT PRIMARY RELAY VALVE?

DECISION

NO - Go to Step (25).

YES - Replace damaged air lines from primary relay valve to rear brake chambers (Volume 5, WP 0805). Go to Step (30) to verify problem is solved.

INSUFFICIENT BRAKES (VEHICLE STOPPING DISTANCE TOO LONG, NO APPARENT AIR SYSTEM FAILURE WITH GAUGES AT NORMAL OPERATING PRESSURE, WARNING BUZZER NOT SOUNDING) - Continued

STEP

25. IS THERE PROPER AIR PRESSURE IN SUPPLY LINE FROM PRIMARY AIR TANK TO RELAY VALVE?
- Stop engine and open all draincocks until brake system air pressure is vented.
 - Close all draincocks.
 - Disconnect pressure gauge from vehicle and return air line and elbow to original condition.

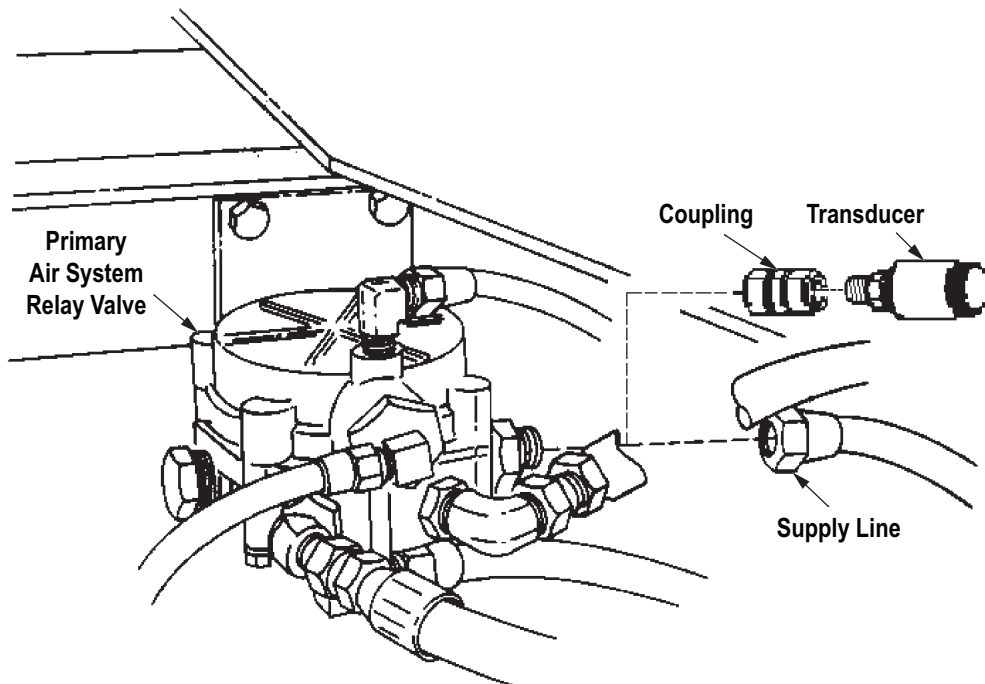

T0193DAA

Figure 24. Primary Relay Valve Supply Port.

INSUFFICIENT BRAKES (VEHICLE STOPPING DISTANCE TOO LONG, NO APPARENT AIR SYSTEM FAILURE WITH GAUGES AT NORMAL OPERATING PRESSURE, WARNING BUZZER NOT SOUNDING) - Continued

- d. Disconnect air line from primary relay valve supply port (Volume 3, WP 0458). Refer to point to point schematics.
- e. Connect pressure gauge to disconnected air supply line.
- f. Assistant starts engine and runs to build air supply to normal operating pressure.
- g. Assistant fully applies and holds service brakes.
- h. Monitor air pressure on pressure gauge.
- i. Pressure gauge should read 90 to 130 psi.

CONDITION/INDICATION

IS THERE PROPER AIR PRESSURE IN SUPPLY LINE FROM PRIMARY AIR TANK TO RELAY VALVE?

DECISION

NO - Replace damaged air line from primary air tank to primary relay valve (Volume 5, WP 0805). Go to Step (30) to verify problem is solved.

YES - Replace primary relay valve (Volume 3, WP 0458). Go to Step (30) to verify problem is solved.

INSUFFICIENT BRAKES (VEHICLE STOPPING DISTANCE TOO LONG, NO APPARENT AIR SYSTEM FAILURE WITH GAUGES AT NORMAL OPERATING PRESSURE, WARNING BUZZER NOT SOUNDING) - Continued

STEP

26. IS PROPER AIR PRESSURE AT SECONDARY RELAY VALVE?

- a. Stop engine and open all draincocks until brake system air pressure is vented.
- b. Close all draincocks.
- c. Disconnect pressure gauge from vehicle and return air line to original condition.

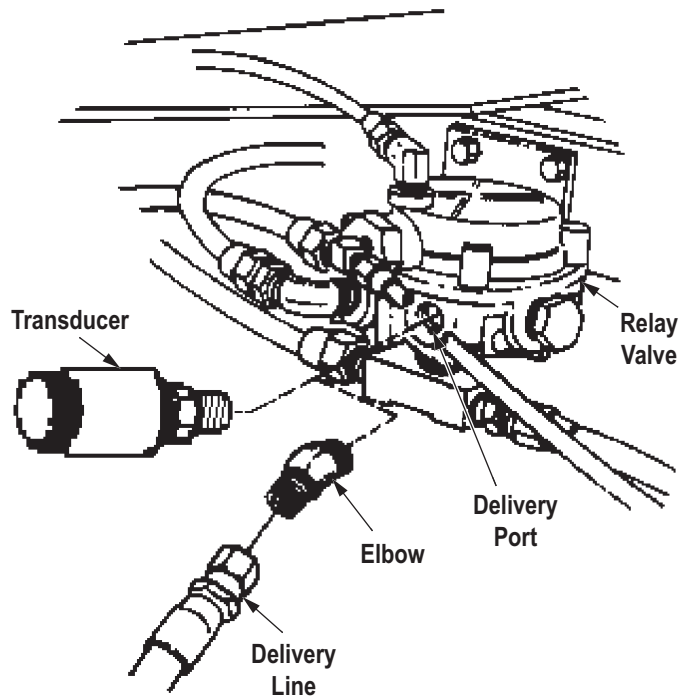

T0194DAA

Figure 25. Secondary Relay Valve Delivery Port.

INSUFFICIENT BRAKES (VEHICLE STOPPING DISTANCE TOO LONG, NO APPARENT AIR SYSTEM FAILURE WITH GAUGES AT NORMAL OPERATING PRESSURE, WARNING BUZZER NOT SOUNDING) - Continued

- d. Disconnect air line from elbow at secondary relay valve delivery port (Volume 3, WP 0457). Refer to point to point schematics.
- e. Remove elbow from secondary relay valve delivery port.
- f. Connect pressure gauge to disconnected relay valve delivery port.
- g. Assistant starts engine and runs to build air supply to normal operating pressure.
- h. Assistant fully applies and holds service brakes.
- i. Monitor air pressure on pressure gauge.
- j. Pressure gauge should read 90 to 130 psi.

CONDITION/INDICATION

IS PROPER AIR PRESSURE AT SECONDARY RELAY VALVE?

DECISION

NO - Go to Step (28).

YES - Replace damaged air lines from secondary relay valve to rear brake chambers (Volume 5, WP 0805).
Go to Step (30) to verify problem is solved.

INSUFFICIENT BRAKES (VEHICLE STOPPING DISTANCE TOO LONG, NO APPARENT AIR SYSTEM FAILURE WITH GAUGES AT NORMAL OPERATING PRESSURE, WARNING BUZZER NOT SOUNDING) - Continued

STEP

27. IS PROPER AIR PRESSURE AT SECONDARY RELAY VALVE?

- a. Stop engine and open all draincocks until brake system air pressure is vented.
- b. Close all draincocks.
- c. Disconnect pressure gauge from vehicle and return air line to original condition.

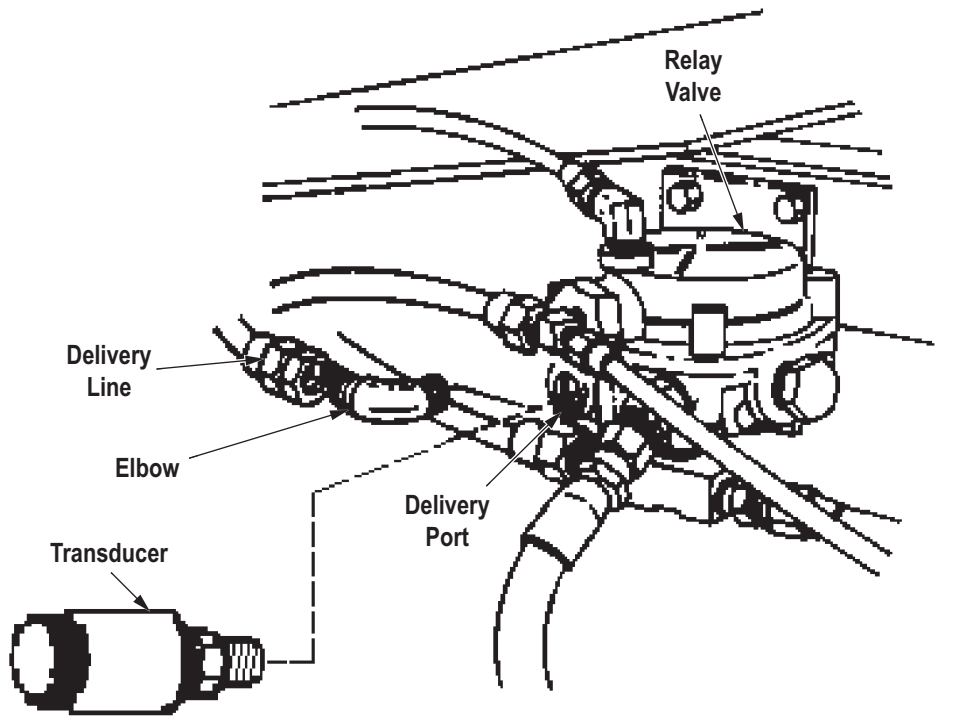

T0196DAA

Figure 26. Secondary Relay Valve Delivery Port.

INSUFFICIENT BRAKES (VEHICLE STOPPING DISTANCE TOO LONG, NO APPARENT AIR SYSTEM FAILURE WITH GAUGES AT NORMAL OPERATING PRESSURE, WARNING BUZZER NOT SOUNDING) - Continued

- d. Disconnect air line from elbow at secondary relay valve delivery port (Volume 3, WP 0457). Refer to point to point schematics.
- e. Remove elbow from secondary relay valve delivery port.
- f. Connect pressure gauge to disconnected relay valve delivery port.
- g. Assistant starts engine and runs to build air supply to normal operating pressure.
- h. Assistant fully applies and holds service brakes.
- i. Monitor air pressure on pressure gauge.
- j. Pressure gauge should read 90 to 130 psi.

CONDITION/INDICATION

IS PROPER AIR PRESSURE AT SECONDARY RELAY VALVE?

DECISION

NO - Go to Step (28).

YES - Replace damaged air lines from secondary relay valve to rear brake chambers (Volume 5, WP 0805).
Go to Step (30) to verify problem is solved.

INSUFFICIENT BRAKES (VEHICLE STOPPING DISTANCE TOO LONG, NO APPARENT AIR SYSTEM FAILURE WITH GAUGES AT NORMAL OPERATING PRESSURE, WARNING BUZZER NOT SOUNDING) - Continued

STEP

28. IS THERE PROPER AIR PRESSURE IN SUPPLY LINE FROM SECONDARY AIR TANK TO RELAY VALVE?
- Stop engine and open all draincocks until brake system air pressure is vented.
 - Close all draincocks.
 - Disconnect pressure gauge from vehicle and return air line and elbow to original condition.

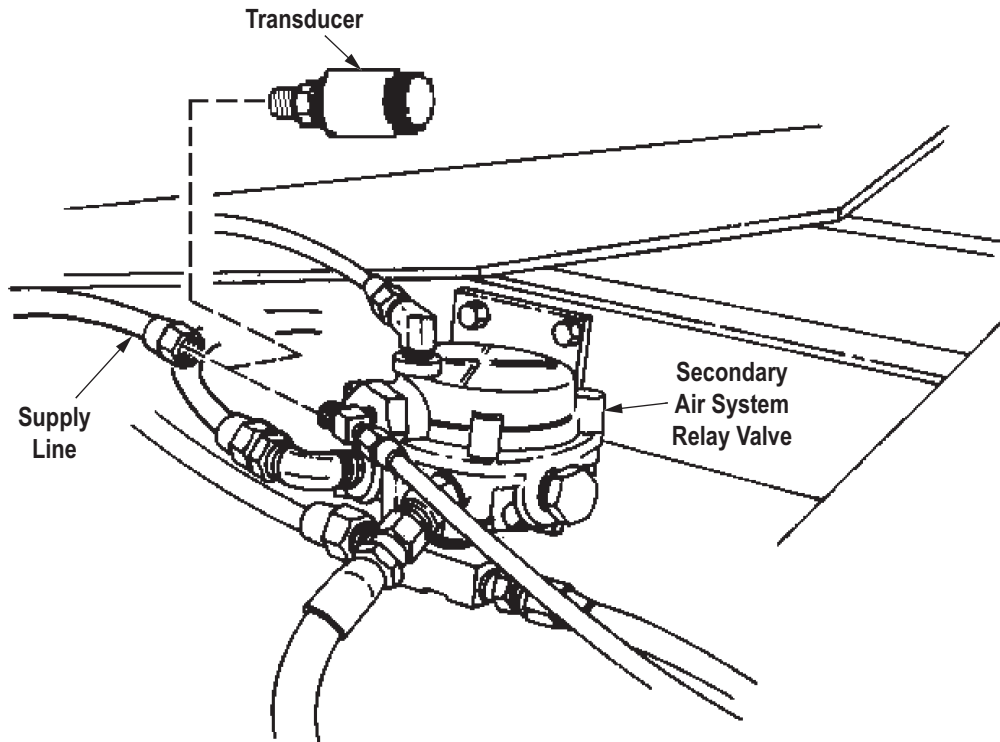

T0198DAA

Figure 27. Secondary Relay Valve Supply Port.

INSUFFICIENT BRAKES (VEHICLE STOPPING DISTANCE TOO LONG, NO APPARENT AIR SYSTEM FAILURE WITH GAUGES AT NORMAL OPERATING PRESSURE, WARNING BUZZER NOT SOUNDING) - Continued

- d. Disconnect air line from secondary relay valve supply port (Volume 3, WP 0457). Refer to point to point schematics.
- e. Connect pressure gauge to disconnected air supply line.
- f. Assistant starts engine and runs to build air supply to normal operating pressure.
- g. Assistant fully applies and holds service brakes.
- h. Monitor air pressure on pressure gauge.
- i. Pressure gauge should read 90 to 130 psi.

CONDITION/INDICATION

IS THERE PROPER AIR PRESSURE IN SUPPLY LINE FROM SECONDARY AIR TANK TO RELAY VALVE?

DECISION

NO - Replace damaged air line from primary air tank to secondary relay valve (Volume 5, WP 0805). Go to Step (30) to verify problem is solved.

YES - Replace secondary relay valve (Volume 3, WP 0457). Go to Step (30) to verify problem is solved.

INSUFFICIENT BRAKES (VEHICLE STOPPING DISTANCE TOO LONG, NO APPARENT AIR SYSTEM FAILURE WITH GAUGES AT NORMAL OPERATING PRESSURE, WARNING BUZZER NOT SOUNDING) - Continued

STEP

29. ARE BRAKE MECHANISMS IN GOOD CONDITION?

- a. Remove brake dust covers (Volume 3, WP 0424).

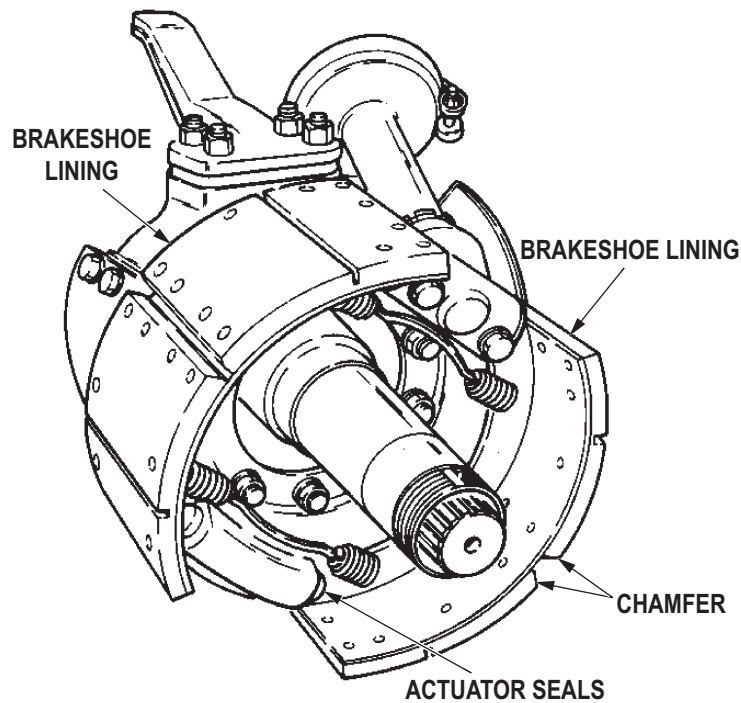

T0199DAA

Figure 28. Brake Assembly.

- b. Inspect chamfer on brakeshoe lining for wear.
- c. Inspect for oil on shoes or drum.
- d. Inspect actuator seals for rotted, torn, or worn condition.

INSUFFICIENT BRAKES (VEHICLE STOPPING DISTANCE TOO LONG, NO APPARENT AIR SYSTEM FAILURE WITH GAUGES AT NORMAL OPERATING PRESSURE, WARNING BUZZER NOT SOUNDING) - Continued

CONDITION/INDICATION

ARE BRAKE MECHANISMS IN GOOD CONDITION?

DECISION

NO - Brakeshoe lining worn. Replace worn brakeshoe linings (Volume 3, WP 0426). Go to Step (30) to verify problem is solved.

NO - Oil on brakeshoes or drum. Notify supervisor. Action may not be possible at this level of maintenance.

NO - Actuator seals are faulty. Notify supervisor. Action may not be possible at this level of maintenance.

YES - Go to Step (30) to verify problem is solved.

STEP

30. IS YOUR ORIGINAL PROBLEM STILL PRESENT?

- a. Ensure vehicle is returned to normal operating condition.
- b. Check to see if your original problem still exists.

CONDITION/INDICATION

IS YOUR ORIGINAL PROBLEM STILL PRESENT?

DECISION

YES - Notify supervisor.

NO - Problem fixed.

END OF WORK PACKAGE

FIELD MAINTENANCE
VEHICLE PULLS RIGHT OR LEFT WHEN APPLYING BRAKES

INITIAL SETUP:**Tools and Special Tools**

Tool Kit, General Mechanic's: Automotive
(Volume 5, WP 0826, Table 1, Item 56)
Gauge, Pressure
(Volume 5, WP 0826, Table 1, Item 19)
Test Set, Electronic Systems
(Volume 5, WP 0826, Table 1, Item 51)

References (cont.)

WP 0053
WP 0120
Volume 3, WP 0424
Volume 3, WP 0426
Volume 3, WP 0432
Volume 3, WP 0434
Volume 3, WP 0479
Volume 3, WP 0481

Personnel Required

(2)

Equipment Condition

Vehicle parked and engine shut down.
(TM 9-2320-272-10)

References

Point to Point Schematics

TROUBLESHOOTING PROCEDURE**VEHICLE PULLS RIGHT OR LEFT WHEN APPLYING BRAKES****NOTE**

- Conduct these malfunction tests if vehicle pulls right or left when applying brakes. This procedure will check for front service brakes grabbing, front service brake chambers for proper air pressure, brakeshoe lining for wear, oil on brakeshoe lining or drum, actuator seals for rotted, torn or worn conditions and proper clearance between brakeshoe lining and drum.
- Vehicle pulling to right or left indicates malfunction in one of the two front wheel service brakes.

VEHICLE PULLS RIGHT OR LEFT WHEN APPLYING BRAKES - Continued**STEP**

1. ARE FRONT SERVICE BRAKES GRABBING?
 - a. Determine which brake is grabbing.
 - b. Start engine and drive vehicle under normal conditions.
 - c. In a safe test area, bring vehicle to a hard, sudden stop.
 - d. Inspect front wheels for excessive heat on wheel and drum.
 - e. Inspect for smoke or skid marks.

CONDITION/INDICATION

ARE FRONT SERVICE BRAKES GRABBING?

DECISION

- YES - Go to Step (3).
NO - Go to Step (2).

STEP

2. DO FRONT BRAKE CHAMBERS HAVE PROPER AIR PRESSURE?
 - a. Check front service brakes for proper air pressure.
 - b. Stop engine and open all draincocks until brake system air pressure is vented.
 - c. Close all draincocks.

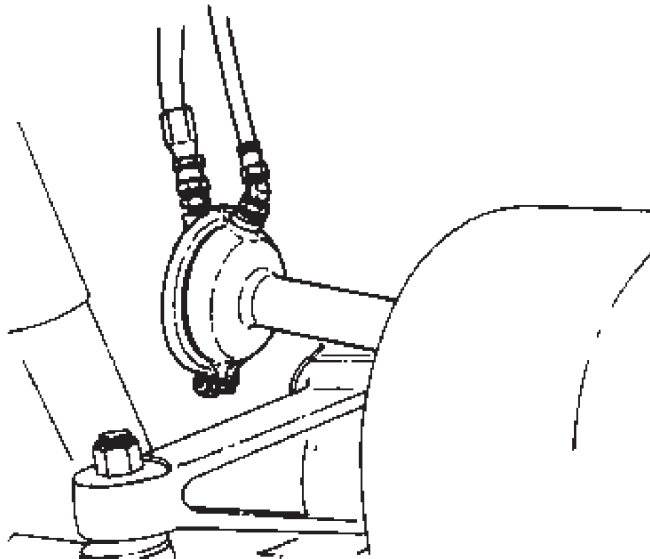

T0228DAA

Figure 1. Front Service Brake Chamber.

VEHICLE PULLS RIGHT OR LEFT WHEN APPLYING BRAKES - Continued

- d. Disconnect delivery line from service brake chamber adapter fitting (Volume 3, WP 0434). Refer to point to point schematics.
- e. Connect tee between disconnected service brake chamber and delivery line.
- f. Connect pressure gauge to tee.
- g. Assistant starts engine and runs to build air supply to normal operating pressure.
- h. Assistant fully applies and holds service brakes while comparing pressure gauge reading to instrument panel primary air pressure gauge reading.
- i. Pressure gauge should read 90 to 130 psi.
- j. Both readings should be similar.

CONDITION/INDICATION

DO FRONT BRAKE CHAMBERS HAVE PROPER AIR PRESSURE?

DECISION

YES - Go to Step (3).

NO - Perform Insufficient Brakes troubleshooting (WP 0120).

VEHICLE PULLS RIGHT OR LEFT WHEN APPLYING BRAKES - Continued**STEP**

3. ARE FRONT BRAKESHOES IN GOOD CONDITION?
 - a. Remove brake dust covers (Volume 3, WP 0424).

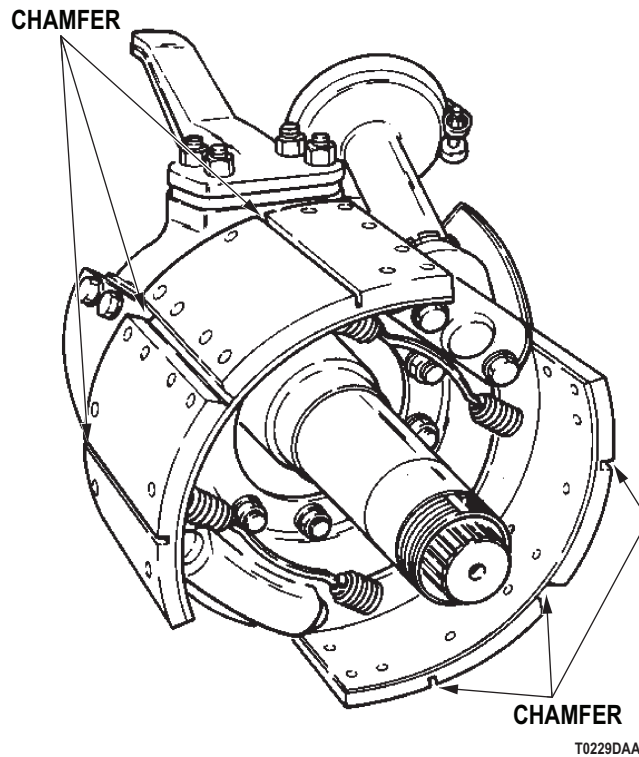

Figure 2. Brake Shoe Assembly.

- b. Inspect chamfer on brakeshoe lining for wear.

CONDITION/INDICATION

ARE FRONT BRAKESHOES IN GOOD CONDITION?

DECISION

NO - Replace worn brakeshoe linings (Volume 3, WP 0426). Go to Step (7) to verify problem is solved.
YES - Go to Step (4).

VEHICLE PULLS RIGHT OR LEFT WHEN APPLYING BRAKES - Continued**STEP****4. IS THERE OIL CONTAMINATION ON FRONT SERVICE BRAKES?**

Visually check brakeshoe lining and drum for oil contamination.

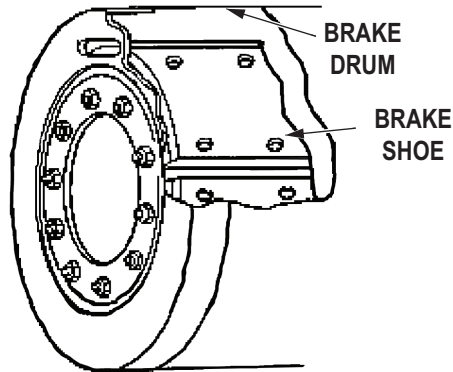

T0230DAA

Figure 3. Brake Drum.

CONDITION/INDICATION

IS THERE OIL CONTAMINATION ON FRONT SERVICE BRAKES?

DECISION

YES - Replace brakeshoe linings (Volume 3, WP 0426) and axle seals M939/A1 (Volume 3, WP 0479), M939A2 (Volume 3, WP 0481), and clean drum M939/A1 (Volume 3, WP 0479), M939A2 (Volume 3, WP 0481). Go to Step (7) to verify problem is solved.
NO - Go to Step (5).

VEHICLE PULLS RIGHT OR LEFT WHEN APPLYING BRAKES - Continued**STEP****5. ARE PLUNGER SEALS IN GOOD OPERATING CONDITION?**

Visually check plunger seals for rotted, torn or worn conditions.

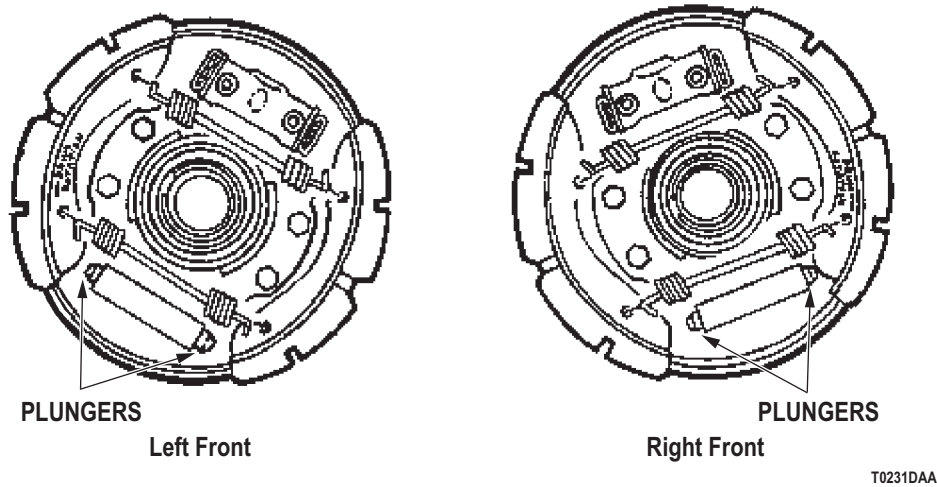

Figure 4. Left and Right Brake Assemblies.

CONDITION/INDICATION

ARE PLUNGER SEALS IN GOOD OPERATING CONDITION?

DECISION

NO - Notify supervisor that brake plunger seals are faulty. Action may not be possible at this level of maintenance.
 YES - Go to Step (6).

VEHICLE PULLS RIGHT OR LEFT WHEN APPLYING BRAKES - Continued**STEP****6. ARE FRONT SERVICE BRAKES PROPERLY ADJUSTED?****NOTE**

Clearance should be between 0.020 to 0.040 in. (0.508 to 1.016 mm).

Check front service brake clearance between brakeshoe lining and drum (Volume 3, WP 0432).

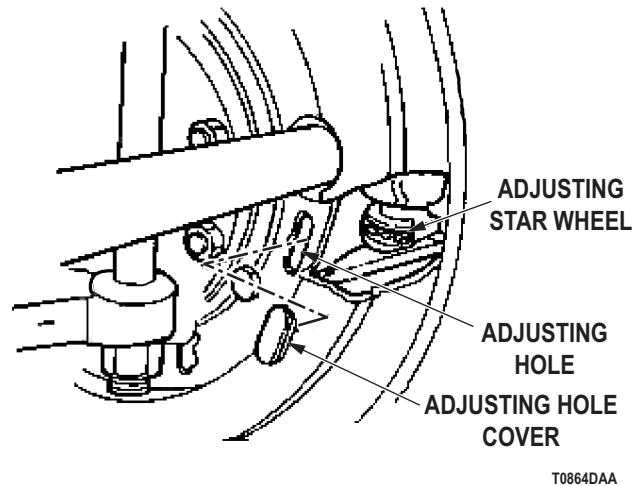

Figure 5. Service Brake Adjustment.

CONDITION/INDICATION

ARE FRONT SERVICE BRAKES PROPERLY ADJUSTED?

DECISION

NO - Adjust front service brakes as necessary (Volume 3, WP 0432). Go to Step (7) to verify problem is solved.
YES - Perform Vehicle Wanders Or Pulls To One Side troubleshooting (WP 0053).

VEHICLE PULLS RIGHT OR LEFT WHEN APPLYING BRAKES - Continued**STEP**

7. IS YOUR ORIGINAL PROBLEM STILL PRESENT?
 - a. Ensure vehicle is returned to normal operating condition.
 - b. Check to see if your original problem still exists.

CONDITION/INDICATION

IS YOUR ORIGINAL PROBLEM STILL PRESENT?

DECISION

YES - Notify supervisor.
NO - Problem fixed.

END OF WORK PACKAGE

**FIELD MAINTENANCE
VEHICLE REAR BRAKES GRAB OR DRAG**

INITIAL SETUP:**Tools and Special Tools**

Tool Kit, General Mechanic's: Automotive
(Volume 5, WP 0826, Table 1, Item 56)
Gauge, Pressure
(Volume 5, WP 0826, Table 1, Item 19)
Test Set, Electronic Systems
(Volume 5, WP 0826, Table 1, Item 51)

Personnel Required

(2)

References

Point to Point Schematics

References (cont.)

WP 0120
Volume 3, WP 0424
Volume 3, WP 0426
Volume 3, WP 0432
Volume 3, WP 0434
Volume 3, WP 0480
Volume 3, WP 0482
Volume 5, WP 0805

Equipment Condition

Vehicle parked and engine shut down.
(TM 9-2320-272-10)

TROUBLESHOOTING PROCEDURE**VEHICLE REAR BRAKES GRAB OR DRAG****NOTE**

Conduct these malfunction tests if vehicle rear brakes grab or drag. This procedure will check for brake mechanism damage or malfunctions, brake system air leaks and proper pressure supply to rear brake chambers.

VEHICLE REAR BRAKES GRAB OR DRAG - Continued**STEP****1. ARE REAR BRAKESHOES IN GOOD CONDITION?**

- a. Look for evidence of locking, smoke, skid marks and excessive heat on wheel and drum to isolate faulty service brake.
- b. Remove rear brake dust covers (Volume 3, WP 0424).

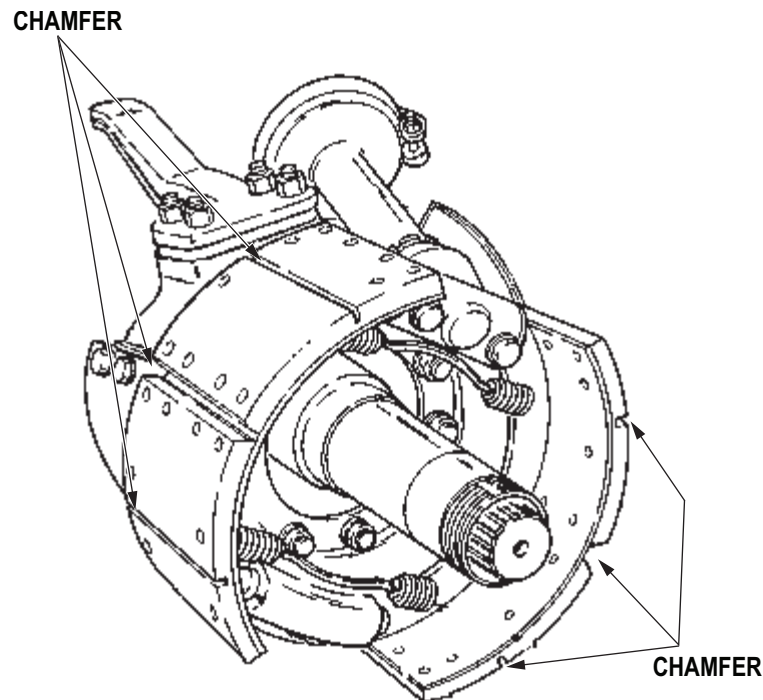

T0234DAA

Figure 1. Brake Shoe Assembly.

NOTE

Brake shoe lining depth should be more than 5/16 (7.94mm).

- c. Inspect chamfer on brakeshoe lining for wear.

CONDITION/INDICATION

ARE REAR BRAKESHOES IN GOOD CONDITION?

DECISION

NO - Replace worn brakeshoe linings (Volume 3, WP 0426). Go to Step (7) to verify problem is solved.
YES - Go to Step (2).

VEHICLE REAR BRAKES GRAB OR DRAG - Continued**STEP****2. IS THERE OIL CONTAMINATION ON REAR SERVICE BRAKES?**

Visually check brakeshoe lining and drum for oil contamination.

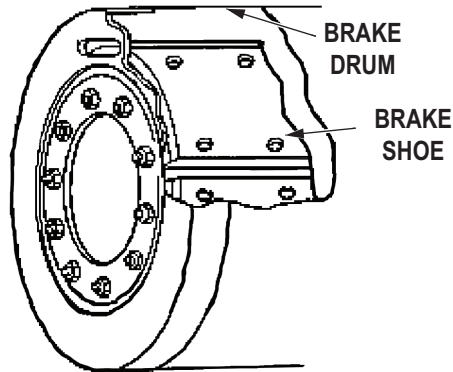

T0235DAA

Figure 2. Brake Drum.

CONDITION/INDICATION

IS THERE OIL CONTAMINATION ON REAR SERVICE BRAKES?

DECISION

YES - Replace brakeshoe linings (Volume 3, WP 0426) and axle seals M939/A1 (Volume 3, WP 0480), M939A2 (Volume 3, WP 0482), and clean drum M939/A1 (Volume 3, WP 0480), M939A2 (Volume 3, WP 0482). Go to Step (7) to verify problem is solved.
NO - Go to Step (3).

VEHICLE REAR BRAKES GRAB OR DRAG - Continued**STEP****3. ARE PLUNGER SEALS IN GOOD OPERATING CONDITION?**

Visually check plunger seals for rotted, torn or worn conditions.

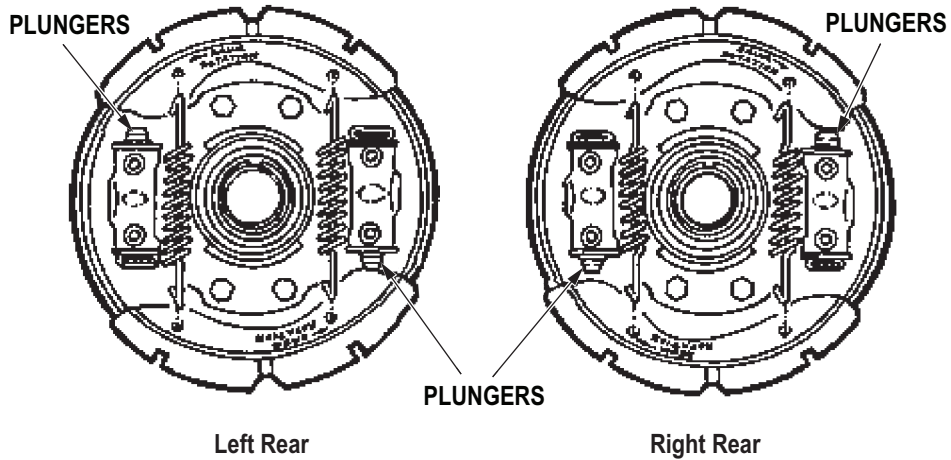

T0236DAA

Figure 3. Left and Right Brake Assemblies.

CONDITION/INDICATION

ARE PLUNGER SEALS IN GOOD OPERATING CONDITION?

DECISION

NO - Notify supervisor that brake plunger seals are faulty. Action may not be possible at this level of maintenance.
YES - Go to Step (4).

VEHICLE REAR BRAKES GRAB OR DRAG - Continued**STEP**

4. ARE REAR SERVICE BRAKES PROPERLY ADJUSTED?

NOTE

Clearance should be between 0.020 to 0.040 in. (0.508 to 1.016 mm).

Check rear service brake clearance between brakeshoe lining and drum (Volume 3, WP 0432).

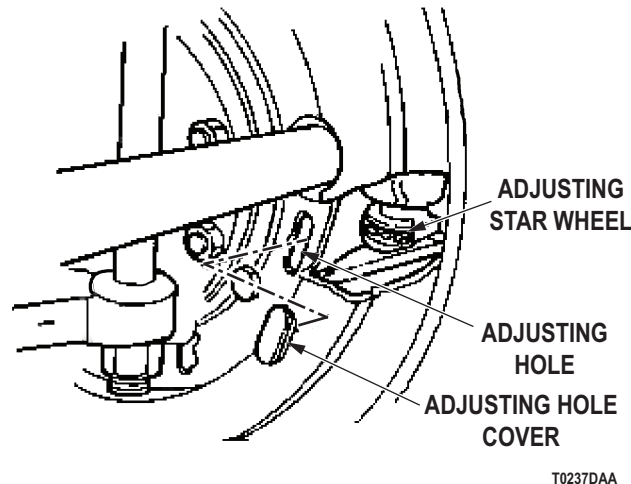

Figure 4. Service Brake Adjustment.

CONDITION/INDICATION

ARE REAR SERVICE BRAKES PROPERLY ADJUSTED?

DECISION

NO - Adjust rear service brakes as necessary (Volume 3, WP 0432). Go to Step (7) to verify problem is solved.
 YES - Go to Step (5).

STEP

5. IS THERE EVIDENCE OF BRAKE SYSTEM AIR LEAKS?
- Start engine and run to build air supply to normal operating pressure.
 - Assistant fully applies service brakes.
 - Listen for leaking air lines or fittings. Refer to point to point schematics.

CONDITION/INDICATION

IS THERE EVIDENCE OF BRAKE SYSTEM AIR LEAKS?

DECISION

YES - Replace damaged air lines (Volume 5, WP 0805). Go to Step (7) to verify problem is solved.
 NO - Go to Step (6).

VEHICLE REAR BRAKES GRAB OR DRAG - Continued**STEP**

6. DO REAR BRAKE CHAMBERS HAVE PROPER AIR PRESSURE?
 - a. Check rear service brakes chambers for proper air pressure.
 - b. Stop engine and open all draincocks until brake system air pressure is vented.
 - c. Close all draincocks.

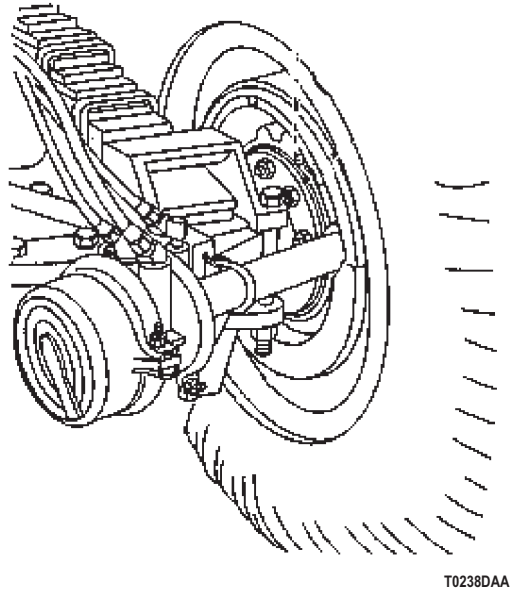

Figure 5. Rear Service Brake Chamber.

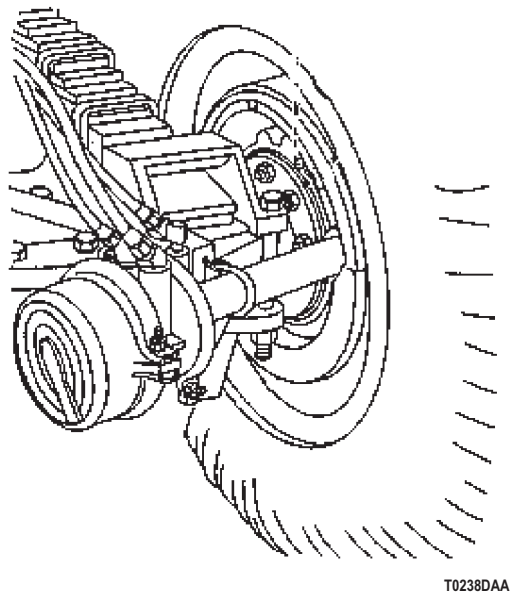

Figure 6. Rear Service and Spring Brake Chamber.

VEHICLE REAR BRAKES GRAB OR DRAG - Continued

- d. Disconnect delivery line from service brake chamber adapter fitting (Volume 3, WP 0435). Refer to point to point schematics.
- e. Connect tee between disconnected service brake chamber and delivery line.
- f. Connect pressure gauge to tee.
- g. Assistant starts engine and runs to build air supply to normal operating pressure.

NOTE

Air pressure to front service brake chambers must compare with reading on secondary air pressure gauge. Air pressure to rear spring and service brake chambers must compare with reading on primary air pressure gauge.

- h. Assistant fully applies and holds service brakes while comparing pressure gauge reading to instrument panel air pressure gauge reading.
- i. Pressure gauge should read 90 to 130 psi.
- j. Both readings should be similar.

CONDITION/INDICATION

DO REAR BRAKE CHAMBERS HAVE PROPER AIR PRESSURE?

DECISION

YES - Go to Step (7) to verify problem is solved.

NO - Perform Insufficient Brakes troubleshooting (WP 0120).

VEHICLE REAR BRAKES GRAB OR DRAG - Continued**STEP**

7. IS YOUR ORIGINAL PROBLEM STILL PRESENT?
 - a. Ensure vehicle is returned to normal operating condition.
 - b. Check to see if your original problem still exists.

CONDITION/INDICATION

IS YOUR ORIGINAL PROBLEM STILL PRESENT?

DECISION

YES - Notify supervisor.
NO - Problem fixed.

END OF WORK PACKAGE

FIELD MAINTENANCE
VEHICLE VIBRATES, CHATTERS, OR BOUNCES WHEN BRAKES ARE APPLIED

INITIAL SETUP:**Tools and Special Tools**

Tool Kit, General Mechanic's: Automotive
(Volume 5, WP 0826, Table 1, Item 56)
Gauge, Pressure
(Volume 5, WP 0826, Table 1, Item 19)
Test Set, Electronic Systems
(Volume 5, WP 0826, Table 1, Item 51)

References (cont.)

WP 0120
WP 0122
Volume 5, WP 0805

Equipment Condition

Vehicle parked and engine shut down.
(TM 9-2320-272-10)

Personnel Required

(2)

References

Point to Point Schematics

TROUBLESHOOTING PROCEDURE**VEHICLE VIBRATES, CHATTERS, OR BOUNCES WHEN BRAKES ARE APPLIED****NOTE**

Conduct these malfunction tests if vehicle vibrates, chatters or bounces when brakes are applied. This procedure will check for faulty or damaged rear brake system mechanism or improper air supply pressure to rear brake chambers.

STEP

1. ARE REAR SERVICE BRAKES LOCKING?
 - a. Visually inspect rear service brakes for evidence of locking.
 - b. Start engine and drive vehicle under normal conditions.
 - c. In a safe test area, bring vehicle to a hard, sudden stop.
 - d. Inspect rear wheels for excessive heat on wheel and drum.
 - e. Inspect for smoke or skid marks.

CONDITION/INDICATION

ARE REAR SERVICE BRAKES LOCKING?

DECISION

YES - Perform Vehicle Rear Brakes Grab Or Drag troubleshooting (WP 0122).
NO - Go to Step (2).

VEHICLE VIBRATES, CHATTERS, OR BOUNCES WHEN BRAKES ARE APPLIED - Continued**STEP**

2. IS THERE EVIDENCE OF BRAKE SYSTEM AIR LEAKS?
 - a. Check for brake system air leaks.
 - b. Start engine and run to build air supply to normal operating pressure.
 - c. Assistant fully applies service brakes.
 - d. Listen for leaking air lines or fittings. Refer to point to point schematics.

CONDITION/INDICATION

IS THERE EVIDENCE OF BRAKE SYSTEM AIR LEAKS?

DECISION

YES - Replace damaged air lines (Volume 5, WP 0805). Go to Step (4) to verify problem is solved.
NO - Go to Step (2).

STEP

3. DO REAR BRAKE CHAMBERS HAVE PROPER AIR PRESSURE?
 - a. Check rear service brakes for proper air pressure.
 - b. Stop engine and open all draincocks until brake system air pressure is vented.
 - c. Close all draincocks.

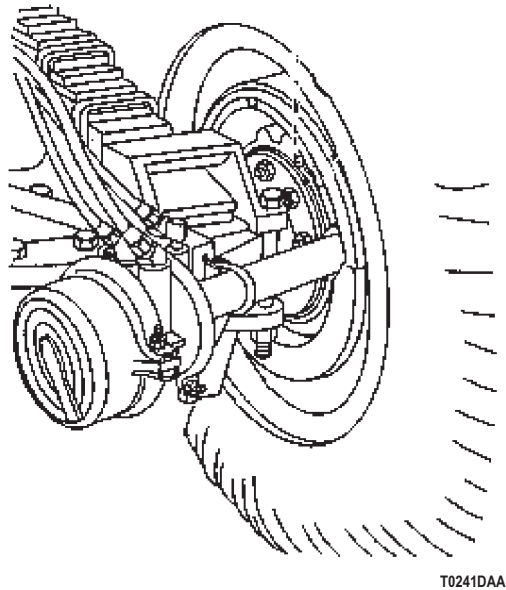

Figure 1. Rear Service Brake Chamber.

VEHICLE VIBRATES, CHATTERS, OR BOUNCES WHEN BRAKES ARE APPLIED - Continued

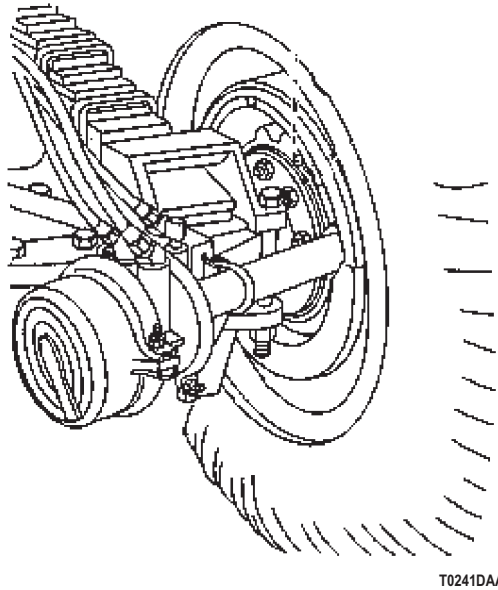

Figure 2. Rear Service and Spring Brake Chamber.

- d. Disconnect delivery line from service brake chamber adapter fitting (Volume 3, WP 0434). Refer to point to point schematics.
- e. Connect tee between disconnected service brake chamber and delivery line.
- f. Connect pressure gauge to tee.
- g. Assistant starts engine and runs to build air supply to normal operating pressure.

NOTE

Air pressure to front service brake chambers must compare with reading on secondary air pressure gauge. Air pressure to rear spring and service brake chambers must compare with reading on primary air pressure gauge.

- h. Assistant fully applies and holds service brakes while comparing pressure gauge reading to instrument panel air pressure gauge reading.
- i. Pressure gauge should read 90 to 130 psi.
- j. Both readings should be similar.

CONDITION/INDICATION

DO REAR BRAKE CHAMBERS HAVE PROPER AIR PRESSURE?

DECISION

YES - Go to Step (4) to verify problem is solved.
 NO - Perform Insufficient Brakes troubleshooting (WP 0120).

VEHICLE VIBRATES, CHATTERS, OR BOUNCES WHEN BRAKES ARE APPLIED - Continued**STEP**

4. IS YOUR ORIGINAL VIBRATION OR BOUNCE PROBLEM STILL PRESENT?
 - a. Ensure vehicle is returned to normal operating condition.
 - b. Check to see if your original vibration or bounce problem still exists.

CONDITION/INDICATION

IS YOUR ORIGINAL VIBRATION OR BOUNCE PROBLEM STILL PRESENT?

DECISION

YES - Notify supervisor.
NO - Problem fixed.

END OF WORK PACKAGE

FIELD MAINTENANCE
BRAKES SQUEAL

INITIAL SETUP:**Tools and Special Tools**

Tool Kit, General Mechanic's: Automotive
(Volume 5, WP 0826, Table 1, Item 56)

Personnel Required

(2)

References

Volume 3, WP 0426

References (cont.)

Volume 3, WP 0479
Volume 3, WP 0480
Volume 3, WP 0481
Volume 3, WP 0482

Equipment Condition

Vehicle parked and engine shut down.
(TM 9-2320-272-10)

TROUBLESHOOTING PROCEDURE**BRAKES SQUEAL****NOTE**

Conduct these malfunction tests if brakes squeal. This procedure will check for worn or glazed brakeshoe lining and for dirt or metal trapped in brakeshoes.

BRAKES SQUEAL - Continued**STEP**

1. ARE BRAKESHOES IN GLAZED OR WORN OUT CONDITION?
 - a. Remove front brakedrums M939/A1 (Volume 3, WP 0479), M939A2 (Volume 3, WP 0481).
 - b. Remove rear brakedrums M939/A1 (Volume 3, WP 0480), M939A2 (Volume 3, WP 0482).

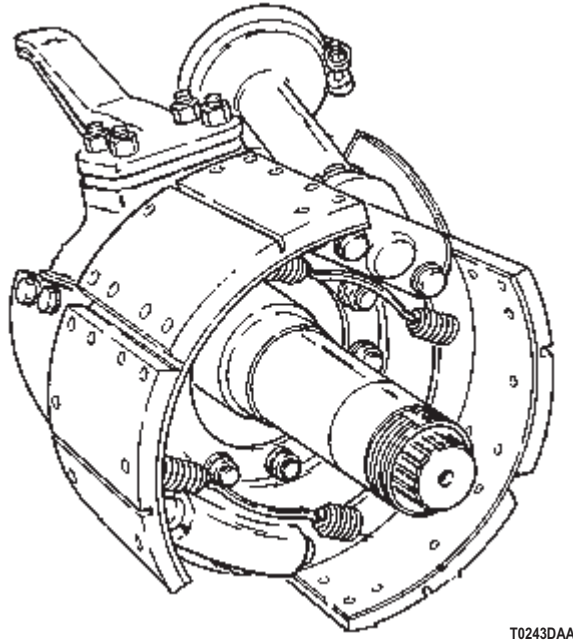

T0243DAA

Figure 1. Brakeshoes.

NOTE

Brakeshoe lining should appear dull.

- c. Visually inspect brakeshoes for glazed lining.
- d. If brakeshoe lining is shiny, remove glaze with wire brush.

NOTE

Brake shoe lining should be greater than 5/16 in (7.94 mm).

- e. Inspect chamfer on brakeshoe lining for wear.

CONDITION/INDICATION

ARE BRAKESHOES IN GLAZED OR WORN OUT CONDITION?

DECISION

- YES - Replace worn out brakeshoes (Volume 3, WP 0426). Go to Step (3) to verify problem is solved.
 NO - Go to Step (2).

BRAKES SQUEAL - Continued**STEP**

2. IS THERE DIRT OR METAL TRAPPED IN BRAKESHOES?
 - a. Visually inspect brakeshoes for trapped dirt or metal contamination.

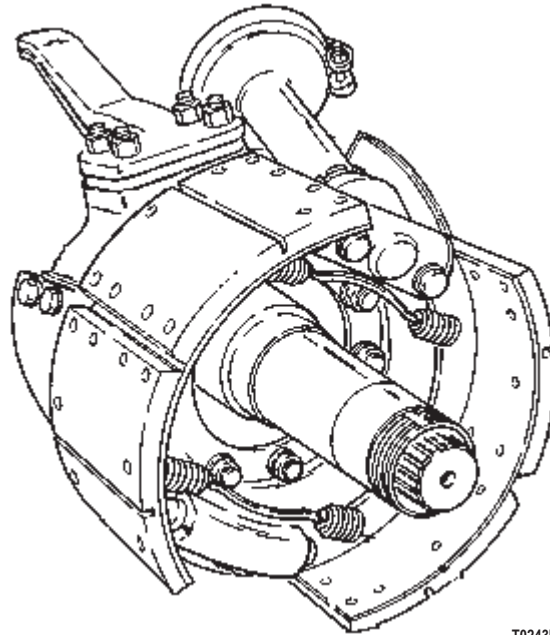

T0243DAA

Figure 2. Brakeshoes.

- b. Clean out dirt or metal contamination with wire brush.

CONDITION/INDICATION

IS THERE DIRT OR METAL TRAPPED IN BRAKESHOES?

DECISION

YES - Replace contaminated brakeshoes (Volume 3, WP 0426). Go to Step (3) to verify problem is solved.
NO - Go to Step (3) to verify problem is solved.

BRAKES SQUEAL - Continued**STEP**

3. IS YOUR ORIGINAL BRAKE SQUEAL PROBLEM STILL PRESENT?
 - a. Ensure vehicle is returned to normal operating condition.
 - b. Check to see if your original vibration or bounce problem still exists.

CONDITION/INDICATION

IS YOUR ORIGINAL BRAKE SQUEAL PROBLEM STILL PRESENT?

DECISION

YES - Notify supervisor.
NO - Problem fixed.

END OF WORK PACKAGE

FIELD MAINTENANCE
WARNING BUZZER SOUNDS WHEN BRAKES ARE APPLIED (PRIMARY & SECONDARY GAUGE PRESSURE DROPS BELOW 55-65 PSI [379-448 KPA])

INITIAL SETUP:**Tools and Special Tools**

Tool Kit, General Mechanic's: Automotive
(Volume 5, WP 0826, Table 1, Item 56)
Test Set, Electronic Systems
(Volume 5, WP 0826, Table 1, Item 51)

Personnel Required

(2)

References

Point to Point Schematics
Volume 5, WP 0805

Equipment Condition

Vehicle parked and engine shut down.
(TM 9-2320-272-10)

TROUBLESHOOTING PROCEDURE**WARNING BUZZER SOUNDS WHEN BRAKES ARE APPLIED (PRIMARY & SECONDARY GAUGE PRESSURE DROPS BELOW 55-65 PSI [379-448 KPA])****NOTE**

Conduct these malfunction tests if warning buzzer sounds when brakes are applied and primary and secondary gauge pressure drops below 55-65 psi. This procedure will check for air leaks in air delivery components.

STEP

1. IS THERE EVIDENCE OF AN AIR LEAK FROM A BRAKE SYSTEM COMPONENT?
 - a. Start engine and run to build air supply to normal operating pressure.
 - b. Assistant fully applies service brakes.
 - c. Listen for and locate any air leaks. Refer to point to point schematics.

CONDITION/INDICATION

IS THERE EVIDENCE OF AN AIR LEAK FROM A BRAKE SYSTEM COMPONENT?

DECISION

YES - Replace damaged air lines (Volume 5, WP 0805). Go to Step (2) to verify problem is solved.
NO - Go to Step (2) to verify problem is solved.

WARNING BUZZER SOUNDS WHEN BRAKES ARE APPLIED (PRIMARY & SECONDARY GAUGE PRESSURE DROPS BELOW 55-65 PSI [379-448 KPA]) - Continued**STEP**

2. IS YOUR ORIGINAL PROBLEM STILL PRESENT?
 - a. Ensure vehicle is returned to normal operating condition.
 - b. Check to see if your original problem still exists.

CONDITION/INDICATION

IS YOUR ORIGINAL PROBLEM STILL PRESENT?

DECISION

YES - Notify supervisor.
NO - Problem fixed.

END OF WORK PACKAGE

FIELD MAINTENANCE
NO AIR PRESSURE (WARNING BUZZER SOUNDING, AIR PRESSURE NOT BUILDING TO NORMAL OPERATING RANGE AS INDICATED BY GAUGES)

INITIAL SETUP:**Tools and Special Tools**

Tool Kit, General Mechanic's: Automotive
(Volume 5, WP 0826, Table 1, Item 56)
Gauge, Pressure
(Volume 5, WP 0826, Table 1, Item 19)
Test Set, Electronic Systems
(Volume 5, WP 0826, Table 1, Item 51)

References (cont.)

WP 0130
WP 0131
Volume 3, WP 0436
Volume 5, WP 0805

Personnel Required

(2)

Equipment Condition

Vehicle parked and engine shut down.
(TM 9-2320-272-10)

References

Point to Point Schematics

TROUBLESHOOTING PROCEDURE**NO AIR PRESSURE (WARNING BUZZER SOUNDING, AIR PRESSURE NOT BUILDING TO NORMAL OPERATING RANGE AS INDICATED BY GAUGES)****NOTE**

Conduct these malfunction tests if there is no air pressure, warning buzzer is sounding and air pressure is not building to normal operating range as indicated by gauges. This procedure will check for air leaks, faulty air compressor, blocked or clogged air lines, faulty air governor or air gauges.

NO AIR PRESSURE (WARNING BUZZER SOUNDING, AIR PRESSURE NOT BUILDING TO NORMAL OPERATING RANGE AS INDICATED BY GAUGES) - Continued

STEP

1. ARE AIR LINES OR FITTINGS LEAKING?

- a. Start engine.

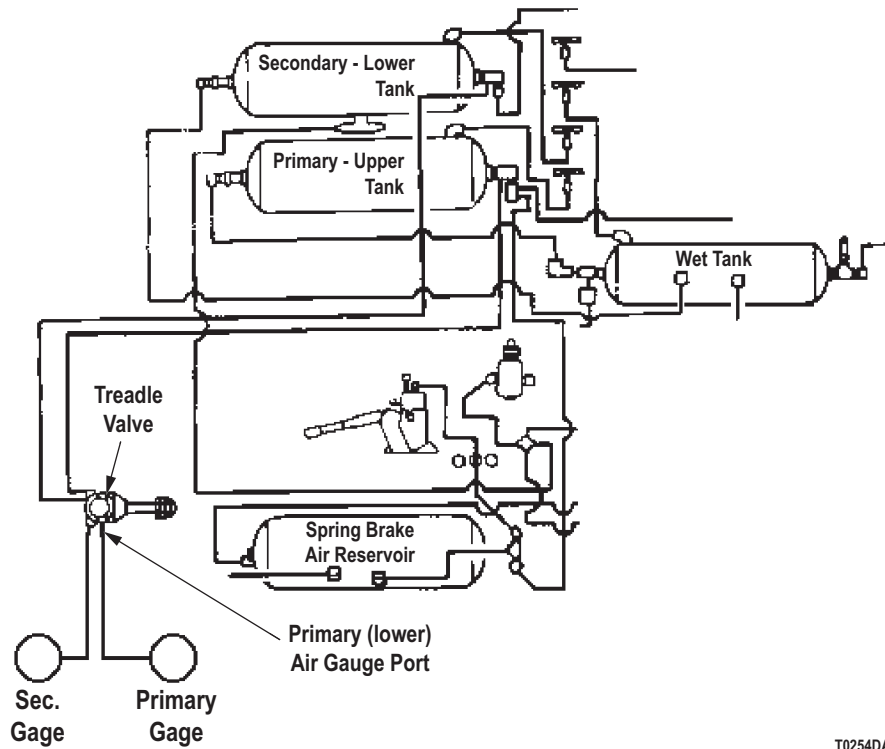

T0254DAA

Figure 1. Air Supply System.

NO AIR PRESSURE (WARNING BUZZER SOUNDING, AIR PRESSURE NOT BUILDING TO NORMAL OPERATING RANGE AS INDICATED BY GAUGES) - Continued

- b. Listen for and locate any air leaks. Refer to point to point schematics.

CONDITION/INDICATION

ARE AIR LINES OR FITTINGS LEAKING?

DECISION

YES - Tighten fittings or replace damaged air lines (Volume 5, WP 0805). Go to Step (6) to verify problem is solved.

NO - Go to Step (2).

NO AIR PRESSURE (WARNING BUZZER SOUNDING, AIR PRESSURE NOT BUILDING TO NORMAL OPERATING RANGE AS INDICATED BY GAUGES) - Continued

STEP

2. IS AIR COMPRESSOR OPERATING NORMALLY?
 - a. Check air compressor operation with engine running.

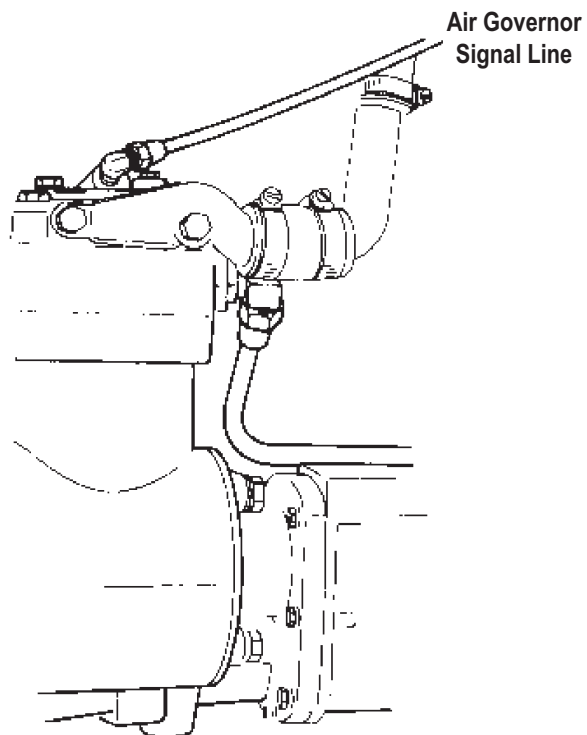

T0868DAA

Figure 2. Air Compressor Governor Signal Line.

- b. Loosen and bleed air from governor signal line to air compressor. Refer to point to point schematics.

NO AIR PRESSURE (WARNING BUZZER SOUNDING, AIR PRESSURE NOT BUILDING TO NORMAL OPERATING RANGE AS INDICATED BY GAUGES) - Continued

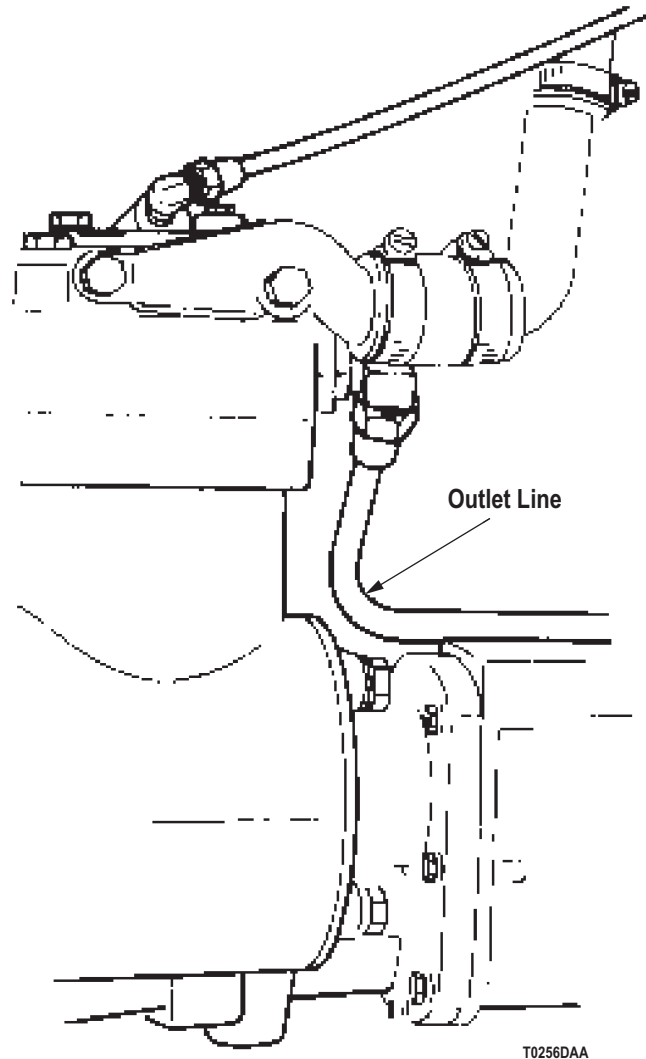

Figure 3. Air Compressor Outlet Line.

- c. Feel compressor outlet line for heat.
- d. If compressor outlet line is hot (under great pressure), compressor is operating normally.
- e. If compressor outlet line is not hot, carefully loosen fitting until air is heard escaping.
- f. If air is escaping, compressor is operating normally.

CONDITION/INDICATION

IS AIR COMPRESSOR OPERATING NORMALLY?

DECISION

NO - Notify supervisor that air compressor is faulty. Action may not be possible at this level of maintenance.
 YES - Go to Step (3).

NO AIR PRESSURE (WARNING BUZZER SOUNDING, AIR PRESSURE NOT BUILDING TO NORMAL OPERATING RANGE AS INDICATED BY GAUGES) - Continued

STEP

3. IS AIR OUTLET LINE IN GOOD CONDITION?

- a. Visually inspect compressor outlet line for damage that could restrict airflow. Refer to point to point schematics.

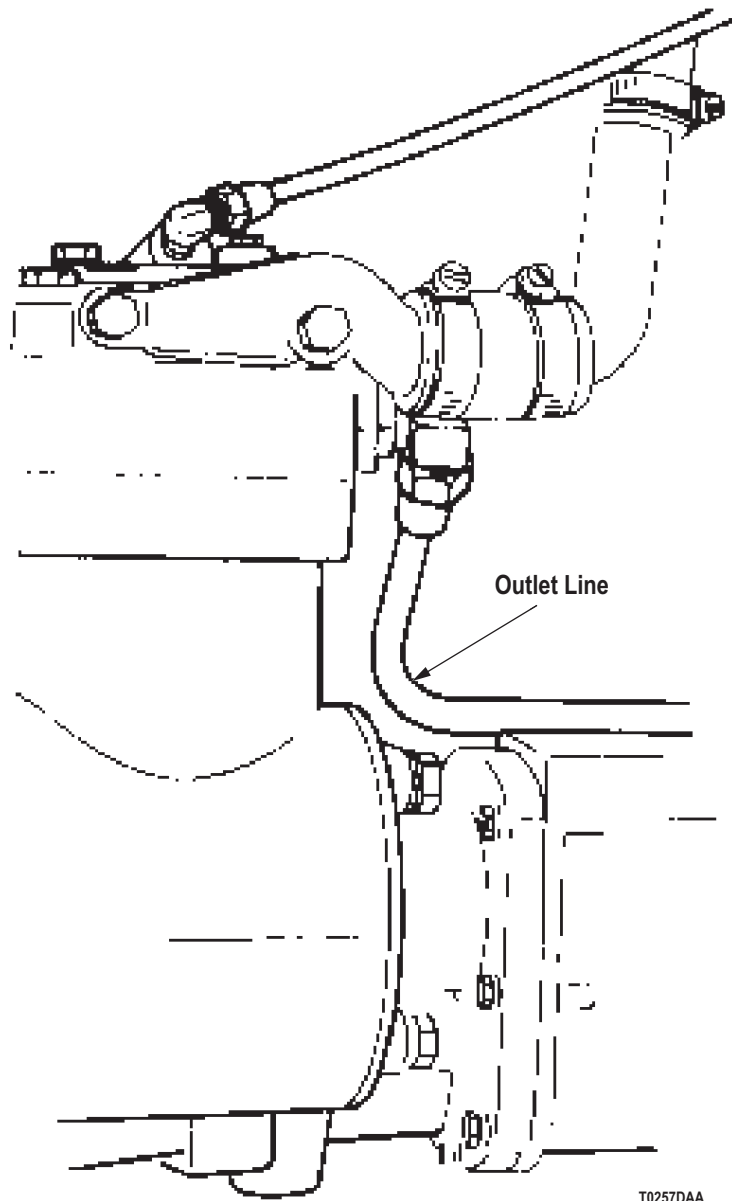

Figure 4. Air Compressor Outlet Line.

- b. Inspect outlet line for blockage.

NO AIR PRESSURE (WARNING BUZZER SOUNDING, AIR PRESSURE NOT BUILDING TO NORMAL OPERATING RANGE AS INDICATED BY GAUGES) - Continued

CONDITION/INDICATION

IS AIR OUTLET LINE IN GOOD CONDITION?

DECISION

NO - Replace damaged air line (Volume 5, WP 0805). Go to Step (6) to verify problem is solved.
YES - Go to Step (4).

NO AIR PRESSURE (WARNING BUZZER SOUNDING, AIR PRESSURE NOT BUILDING TO NORMAL OPERATING RANGE AS INDICATED BY GAUGES) - Continued

STEP

4. ARE AIR GAUGES WORKING PROPERLY?
 - a. Check air gauges reading accuracy.
 - b. Stop engine and open all draincocks until brake system air pressure is vented.
 - c. Close draincocks.

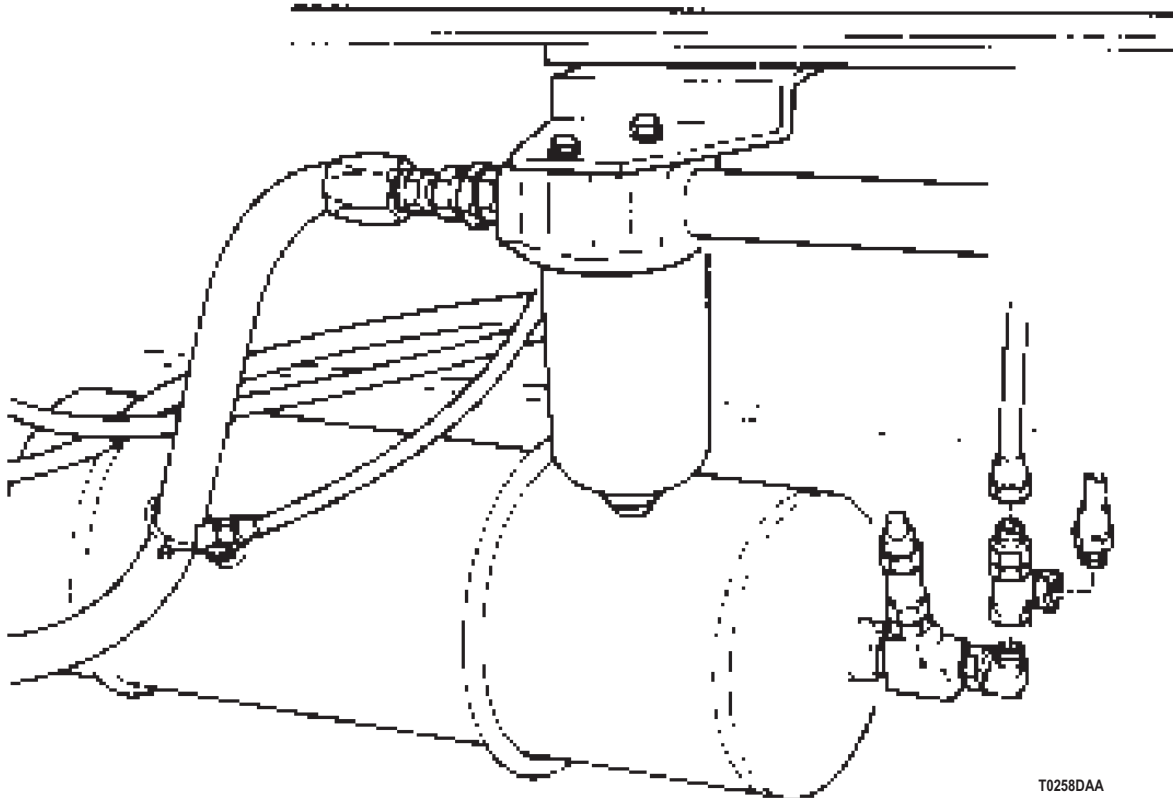

T0258DAA

Figure 5. Wet Supply Tank.

- d. Disconnect outlet line at wet supply tank and install tee between tank and line. Refer to point to point schematics.
- e. Install pressure gauge on tee.
- f. Start engine and allow sufficient time for air to build to normal operating pressure.

NO AIR PRESSURE (WARNING BUZZER SOUNDING, AIR PRESSURE NOT BUILDING TO NORMAL OPERATING RANGE AS INDICATED BY GAUGES) - Continued

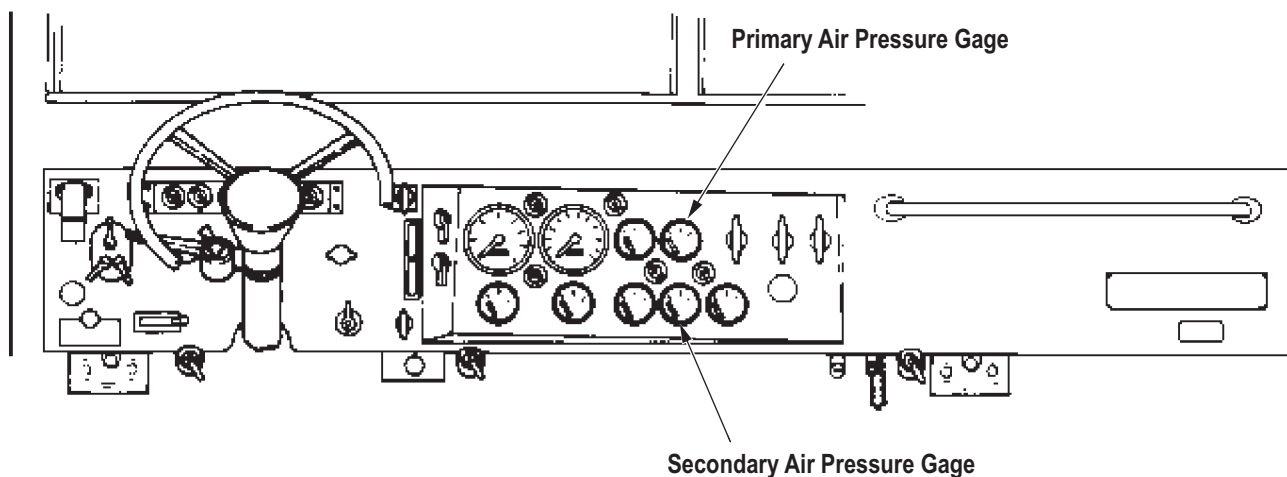

T0253DAA

Figure 6. Air Pressure Gauges.

- g. Compare pressure gauge reading with reading on instrument panel air pressure gauges.
- h. If instrument panel air pressure gauge reading is different than pressure gauge reading, instrument panel air pressure gauge is not working properly.

CONDITION/INDICATION

ARE AIR GAUGES WORKING PROPERLY?

DECISION

NO - Primary air system pressure gauge not reading properly. Perform Primary Pressure Gauge Reads No Pressure, Low Pressure, or Builds To Normal Pressure Slowly troubleshooting (WP 0130).
 NO - Secondary air system pressure gauge not reading properly. Perform Secondary Pressure Gauge Reads No Pressure, Low Pressure, or Builds To Normal Pressure Slowly troubleshooting (WP 0131).
 YES - Go to Step (5).

NO AIR PRESSURE (WARNING BUZZER SOUNDING, AIR PRESSURE NOT BUILDING TO NORMAL OPERATING RANGE AS INDICATED BY GAUGES) - Continued**STEP****5. IS AIR GOVERNOR OPERATING PROPERLY?**

- a. Replace air governor with a known good governor (Volume 3, WP 0436).

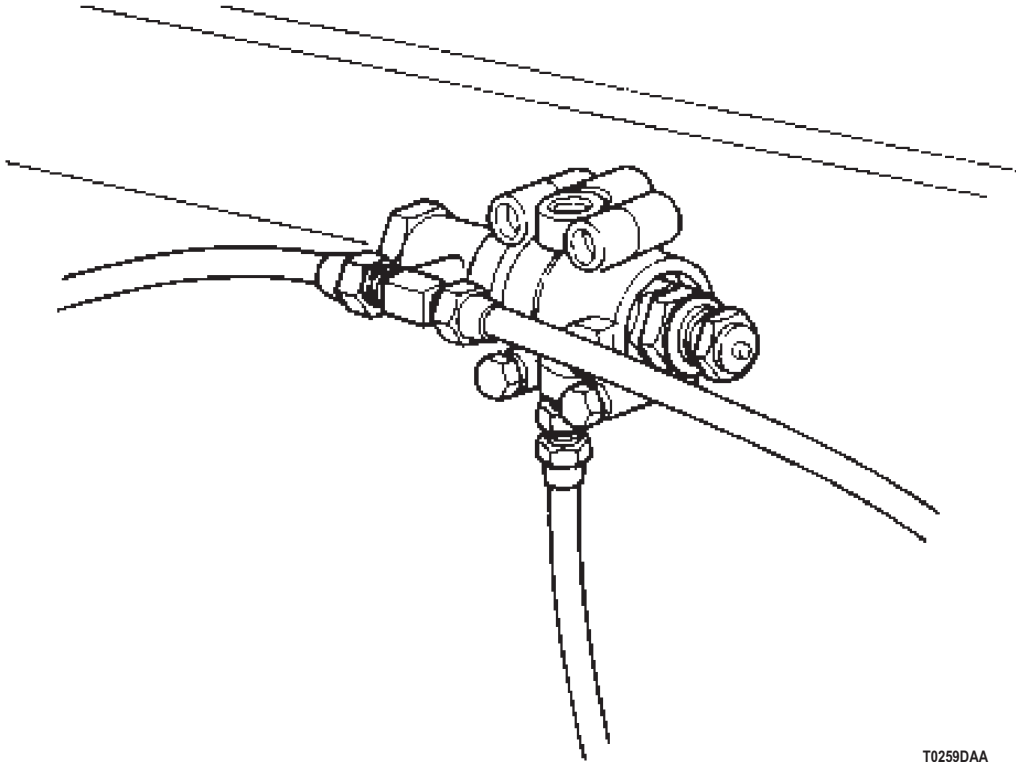

T0259DAA

Figure 7. Air Governor.

- b. Start engine and allow sufficient time for air to build to normal operating pressure.
- c. If air pressure gauges read 90 to 130 psi, air governor was not operating properly.

CONDITION/INDICATION

IS AIR GOVERNOR OPERATING PROPERLY?

DECISION

NO - Replace defective air governor (Volume 3, WP 0436). Go to Step (6) to verify problem is solved.
YES - Notify supervisor. Action may not be possible at this level of maintenance.

NO AIR PRESSURE (WARNING BUZZER SOUNDING, AIR PRESSURE NOT BUILDING TO NORMAL OPERATING RANGE AS INDICATED BY GAUGES) - Continued

STEP

6. IS YOUR ORIGINAL AIR PRESSURE PROBLEM STILL PRESENT?
 - a. Ensure vehicle is returned to normal operating condition.
 - b. Check to see if your original problem still exists.

CONDITION/INDICATION

IS YOUR ORIGINAL AIR PRESSURE PROBLEM STILL PRESENT?

DECISION

YES - Notify supervisor.
NO - Problem fixed.

END OF WORK PACKAGE

FIELD MAINTENANCE
AIR PRESSURE DOES NOT BUILD TO NORMAL OPERATING PRESSURE (ABOVE 80 PSI [552 KPA])
ACCORDING TO GAUGES

INITIAL SETUP:**Tools and Special Tools**

Tool Kit, General Mechanic's: Automotive
(Volume 5, WP 0826, Table 1, Item 56)
Test Set, Electronic Systems
(Volume 5, WP 0826, Table 1, Item 51)

References (cont.)

WP 0126
Volume 3, WP 0436
Volume 5, WP 0805

Personnel Required

(2)

Equipment Condition

Vehicle parked and engine shut down.
(TM 9-2320-272-10)

References

Point to Point Schematics

TROUBLESHOOTING PROCEDURE

AIR PRESSURE DOES NOT BUILD TO NORMAL OPERATING PRESSURE (ABOVE 80 PSI [552 KPA])
ACCORDING TO GAUGES

NOTE

Conduct these malfunction tests if air pressures do not build to normal operating pressure (above 80 psi [552 kPa]) according to gauges. This procedure will check for air leaks from lines or fittings, adjust air governor and check for faulty compressor.

**AIR PRESSURE DOES NOT BUILD TO NORMAL OPERATING PRESSURE (ABOVE 80 PSI [552 KPA])
ACCORDING TO GAUGES - Continued**

STEP

1. ARE AIR LINES OR FITTINGS LEAKING?

- a. Start engine.

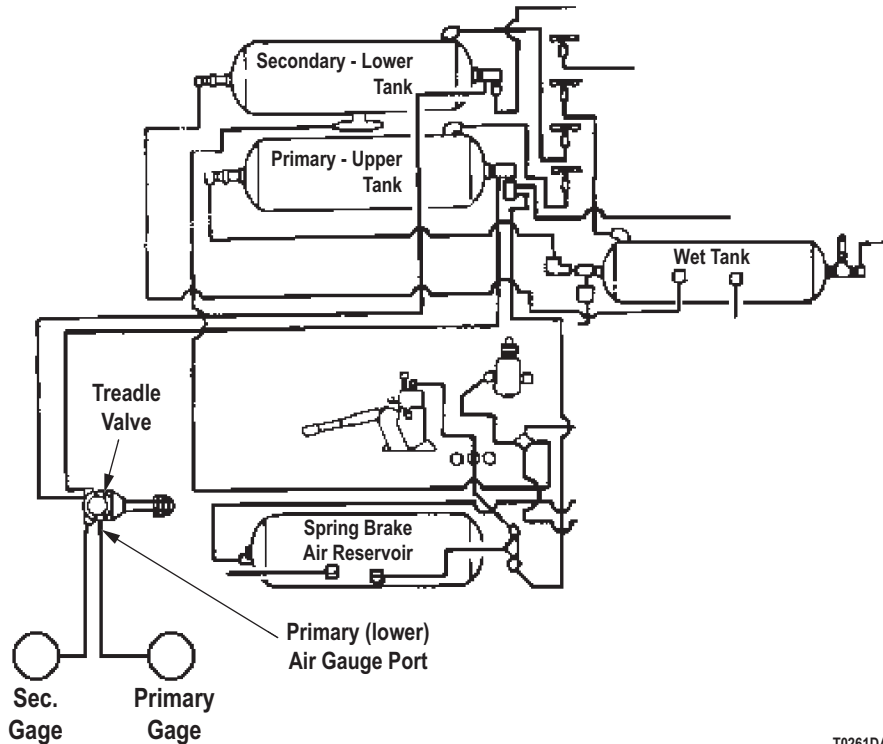

T0261DAA

Figure 1. Air Supply System.

- b. Listen and locate air leaks. Refer to point to point schematics.

CONDITION/INDICATION

ARE AIR LINES OR FITTINGS LEAKING?

DECISION

YES - Tighten fittings or replace damaged air lines (Volume 5, WP 0805). Go to Step (3) to verify problem is solved.

NO - Go to Step (2).

STEP

2. CAN AIR GOVERNOR BE PROPERLY ADJUSTED?

- a. Check if air governor is properly adjusted. Refer to point to point schematics.

**AIR PRESSURE DOES NOT BUILD TO NORMAL OPERATING PRESSURE (ABOVE 80 PSI [552 KPA])
ACCORDING TO GAUGES - Continued**

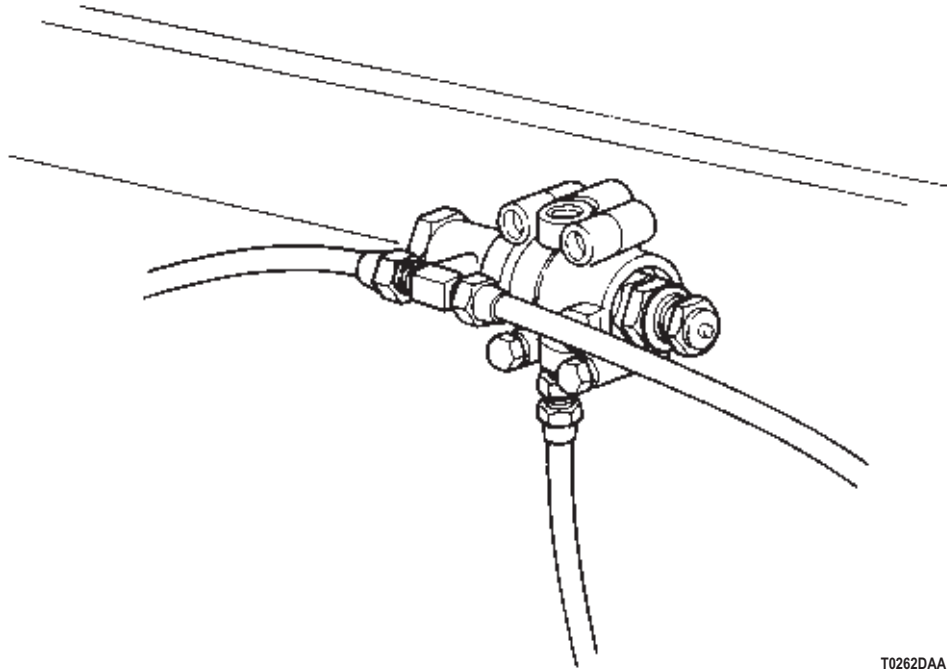

T0262DAA

Figure 2. Air Governor.

- b. Adjust governor to proper settings (Volume 3, WP 0436).

CONDITION/INDICATION

CAN AIR GOVERNOR BE PROPERLY ADJUSTED?

DECISION

NO - Perform No Air Pressure troubleshooting (WP 0126).
YES - Go to Step (3) to verify problem is solved.

STEP

3. IS YOUR ORIGINAL AIR PRESSURE PROBLEM STILL PRESENT?
 - a. Ensure vehicle is returned to normal operating condition.
 - b. Check to see if your original problem still exists.

CONDITION/INDICATION

IS YOUR ORIGINAL AIR PRESSURE PROBLEM STILL PRESENT?

DECISION

YES - Notify supervisor.
NO - Problem fixed.

END OF WORK PACKAGE

FIELD MAINTENANCE**AIR PRESSURE BUILDS SLOWLY (TAKES EXCESSIVE AMOUNT OF TIME TO BUILD TO 100 PSI (690KPA))**

INITIAL SETUP:**Tools and Special Tools**

Tool Kit, General Mechanic's: Automotive
(Volume 5, WP 0826, Table 1, Item 56)
Test Set, Electronic Systems
(Volume 5, WP 0826, Table 1, Item 51)

References (cont.)

WP 0126
Volume 3, WP 0436
Volume 5, WP 0805

Personnel Required

(2)

Equipment Condition

Vehicle parked and engine shut down.
(TM 9-2320-272-10)

References

Point to Point Schematics

TROUBLESHOOTING PROCEDURE**AIR PRESSURE BUILDS SLOWLY (TAKES EXCESSIVE AMOUNT OF TIME TO BUILD TO 100 PSI (690KPA))****NOTE**

Conduct these malfunction tests if air pressure builds slowly (takes excessive amount of time to build to 100 psi [690kPa]). This procedure will check for air leaks form lines or fittings, improperly adjusted air governor or faulty compressor.

AIR PRESSURE BUILDS SLOWLY (TAKES EXCESSIVE AMOUNT OF TIME TO BUILD TO 100 PSI (690KPA))
- Continued

STEP

1. ARE AIR LINES OR FITTINGS LEAKING?

- a. Start engine.

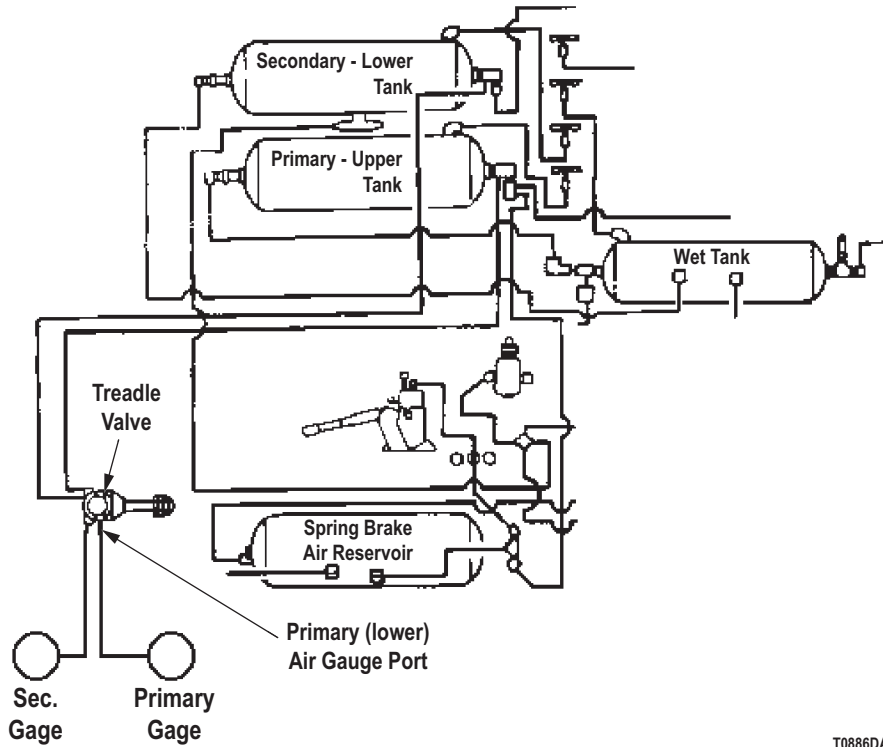

T0886DAA

Figure 1. Air Supply System.

- b. Listen and locate air leaks. Refer to point to point schematics.

CONDITION/INDICATION

ARE AIR LINES OR FITTINGS LEAKING?

DECISION

YES - Tighten fittings or replace damaged air lines (Volume 5, WP 0805). Go to Step (3) to verify problem is solved.

NO - Go to Step (2).

STEP

2. CAN AIR GOVERNOR BE PROPERLY ADJUSTED?

- a. Check if air governor is properly adjusted. Refer to point to point schematics.

AIR PRESSURE BUILDS SLOWLY (TAKES EXCESSIVE AMOUNT OF TIME TO BUILD TO 100 PSI (690KPA))
- Continued

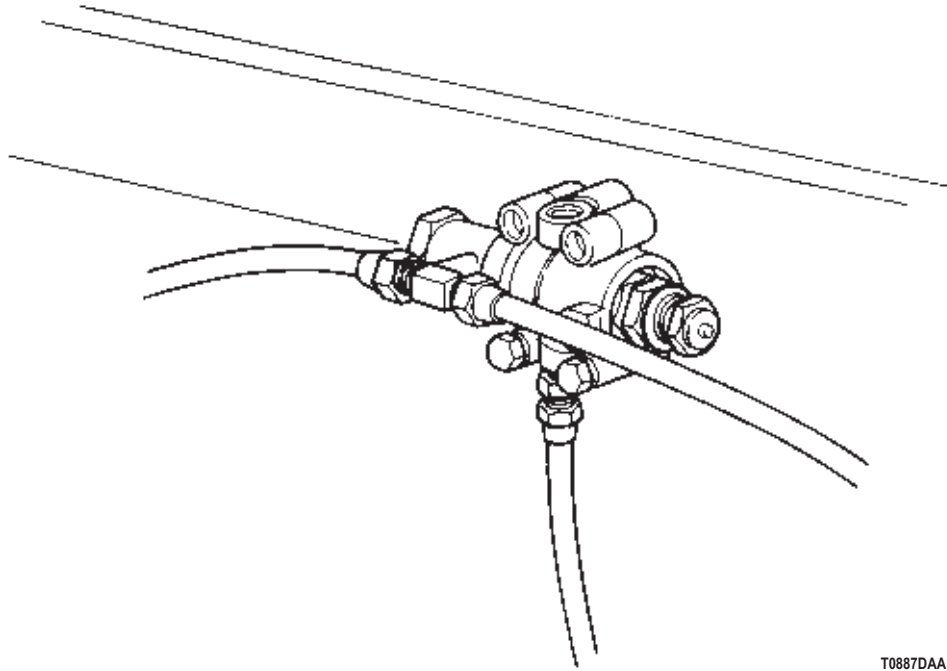

T0887DAA

Figure 2. Air Governor.

- b. Adjust governor to proper settings (Volume 3, WP 0436).

CONDITION/INDICATION

CAN AIR GOVERNOR BE PROPERLY ADJUSTED?

DECISION

NO - Perform No Air Pressure troubleshooting (WP 0126).
 YES - Go to Step (3) to verify problem is solved.

STEP

3. IS YOUR ORIGINAL AIR PRESSURE PROBLEM STILL PRESENT?
 - a. Ensure vehicle is returned to normal operating condition.
 - b. Check to see if your original problem still exists.

CONDITION/INDICATION

IS YOUR ORIGINAL AIR PRESSURE PROBLEM STILL PRESENT?

DECISION

YES - Notify supervisor.
 NO - Problem fixed.

END OF WORK PACKAGE

FIELD MAINTENANCE
AIR PRESSURE EXCEEDS MAXIMUM (GAUGES SHOW OVER 130 PSI [896 KPA]), SAFETY VALVE OPENS TO RELEASE PRESSURE

INITIAL SETUP:

Tools and Special Tools

Tool Kit, General Mechanic's: Automotive
(Volume 5, WP 0826, Table 1, Item 56)
Gauge, Pressure
(Volume 5, WP 0826, Table 1, Item 19)
Test Set, Electronic Systems
(Volume 5, WP 0826, Table 1, Item 51)

References (cont.)

Volume 3, WP 0436
Volume 5, WP 0805

Equipment Condition

Vehicle parked and engine shut down.
(TM 9-2320-272-10)

Personnel Required

(2)

References

Point to Point Schematics

TROUBLESHOOTING PROCEDURE

AIR PRESSURE EXCEEDS MAXIMUM (GAUGES SHOW OVER 130 PSI [896 KPA]), SAFETY VALVE OPENS TO RELEASE PRESSURE

NOTE

Conduct these malfunction tests if air pressure exceeds maximum (gauges show over 130 psi), safety valve opens to release pressure.

AIR PRESSURE EXCEEDS MAXIMUM (GAUGES SHOW OVER 130 PSI [896 KPA]), SAFETY VALVE OPENS TO RELEASE PRESSURE - Continued

STEP

1. IS THERE EVIDENCE OF AIR LOSS THROUGH ACCESSORIES?
 - a. Visually inspect air accessories for air leaks.
 - b. Start engine.

AUXILIARY AIR-POWER SYSTEM

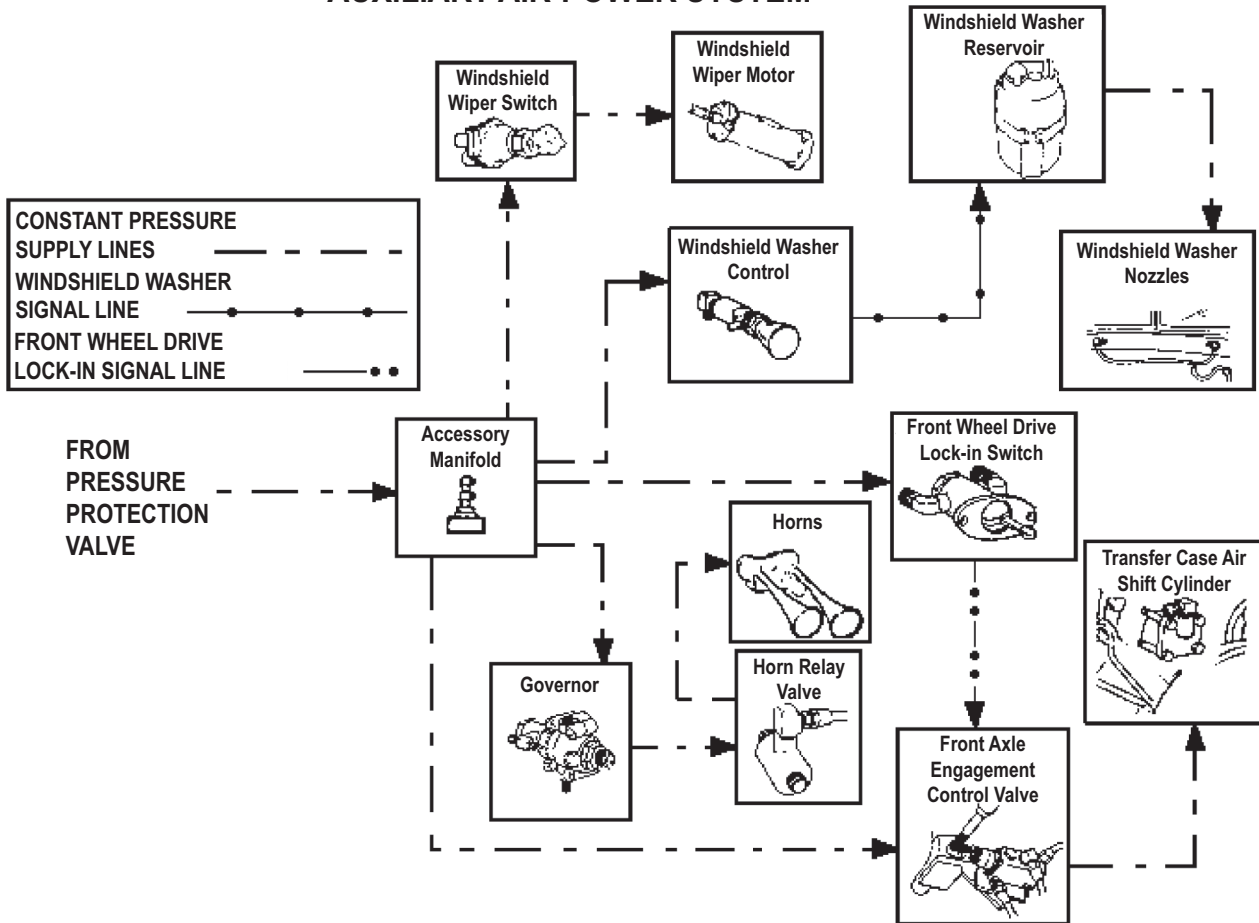

T0266DAA

Figure 1. Auxiliary Air Power System.

- c. Listen and locate air leaks. Refer to point to point schematics.

CONDITION/INDICATION

IS THERE EVIDENCE OF AIR LOSS THROUGH ACCESSORIES?

DECISION

- YES - Replace leaking accessory. Go to Step (4) to verify problem is solved.
- NO - Go to Step (2).

AIR PRESSURE EXCEEDS MAXIMUM (GAUGES SHOW OVER 130 PSI [896 KPA]), SAFETY VALVE OPENS TO RELEASE PRESSURE - Continued**STEP****2. IS GOVERNOR SIGNAL LINE IN GOOD CONDITION?**

- a. Visually check governor signal line for leaks and crimping. Refer to point to point schematics.

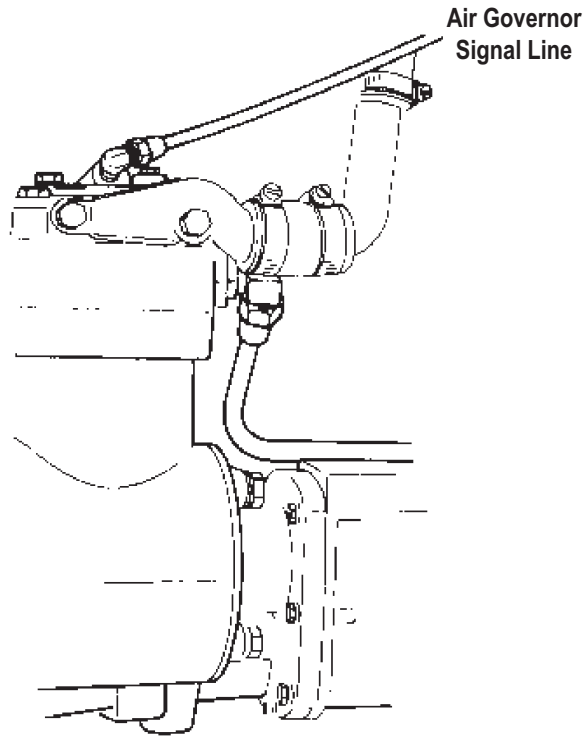

T0267DAA

Figure 2. Air Governor Signal Line.

- b. Remove governor signal line and inspect for clogging.

CONDITION/INDICATION

IS GOVERNOR SIGNAL LINE IN GOOD CONDITION?

DECISION

NO - Clear or replace damaged air line (Volume 5, WP 0805). Go to Step (4) to verify problem is solved.
YES - Go to Step (3) to verify problem is solved.

AIR PRESSURE EXCEEDS MAXIMUM (GAUGES SHOW OVER 130 PSI [896 KPA]), SAFETY VALVE OPENS TO RELEASE PRESSURE - Continued

STEP

3. DOES GOVERNOR SIGNAL LINE HAVE PROPER AIR PRESSURE?
 - a. Check governor line for proper air pressure.
 - b. Stop engine and open all draincocks until brake system air pressure is vented.
 - c. Close draincocks.

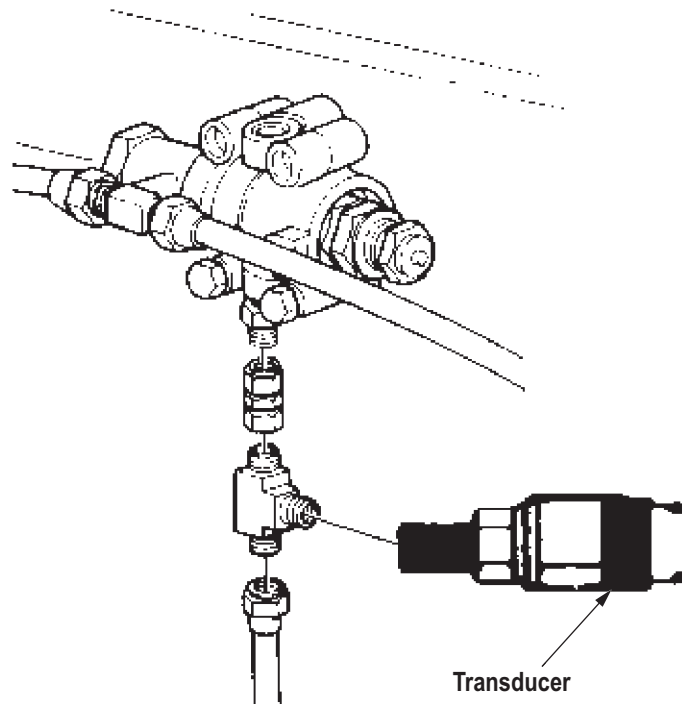

T0268DAA

Figure 3. Air Governor Signal Line.

- d. Disconnect governor signal line from air governor. Refer to point to point schematics.
- e. Connect adapter fitting to air governor and tee to fitting.
- f. Install pressure gauge on tee.
- g. Start engine and allow sufficient time for air to build to normal operating pressure.
- h. Pressure gauge reading should be above 80 psi.
- i. Compare pressure gauge reading with reading on instrument panel air pressure gauges.

CONDITION/INDICATION

DOES GOVERNOR SIGNAL LINE HAVE PROPER AIR PRESSURE?

DECISION

NO - Notify supervisor. Action may not be possible at this level of maintenance.

AIR PRESSURE EXCEEDS MAXIMUM (GAUGES SHOW OVER 130 PSI [896 KPA]), SAFETY VALVE OPENS TO RELEASE PRESSURE - Continued

YES - Replace defective air governor (Volume 3, WP 0436). Go to Step (4) to verify problem is solved.

STEP

4. IS YOUR ORIGINAL AIR PRESSURE PROBLEM STILL PRESENT?
 - a. Ensure vehicle is returned to normal operating condition.
 - b. Check to see if your original problem still exists.

CONDITION/INDICATION

IS YOUR ORIGINAL AIR PRESSURE PROBLEM STILL PRESENT?

DECISION

YES - Notify supervisor.
NO - Problem fixed.

END OF WORK PACKAGE

FIELD MAINTENANCE

PRIMARY PRESSURE GAUGE READS NO PRESSURE, LOW PRESSURE, OR BUILDS TO NORMAL OPERATING PRESSURE SLOWLY. SECONDARY PRESSURE GAUGE READS NORMAL (ENGINE IDLING, BRAKE PEDAL NOT APPLIED)

INITIAL SETUP:**Tools and Special Tools**

Tool Kit, General Mechanic's: Automotive
(Volume 5, WP 0826, Table 1, Item 56)
Gauge, Pressure
(Volume 5, WP 0826, Table 1, Item 19)
Test Set, Electronic Systems
(Volume 5, WP 0826, Table 1, Item 51)

References (cont.)

Volume 3, WP 0428
Volume 3, WP 0429
Volume 3, WP 0430
Volume 5, WP 0805
Volume 5, WP 0818

Personnel Required

(2)

Equipment Condition

Vehicle parked and engine shut down.
(TM 9-2320-272-10)

References

Point to Point Schematics

TROUBLESHOOTING PROCEDURE

PRIMARY PRESSURE GAUGE READS NO PRESSURE, LOW PRESSURE, OR BUILDS TO NORMAL OPERATING PRESSURE SLOWLY. SECONDARY PRESSURE GAUGE READS NORMAL (ENGINE IDLING, BRAKE PEDAL NOT APPLIED)

NOTE

Conduct these malfunction tests if primary air pressure gauge reads no pressure, low pressure or builds slowly to normal operating pressure, secondary air pressure gauge reads normal. This procedure will check for air leaks from lines or fittings, faulty primary air pressure gauge, clogged air supply lines, faulty brake pedal valve or one-way check valve.

PRIMARY PRESSURE GAUGE READS NO PRESSURE, LOW PRESSURE, OR BUILDS TO NORMAL OPERATING PRESSURE SLOWLY. SECONDARY PRESSURE GAUGE READS NORMAL (ENGINE IDLING, BRAKE PEDAL NOT APPLIED) - Continued

STEP

1. ARE AIR LINES OR FITTINGS LEAKING?
 - a. Start engine.

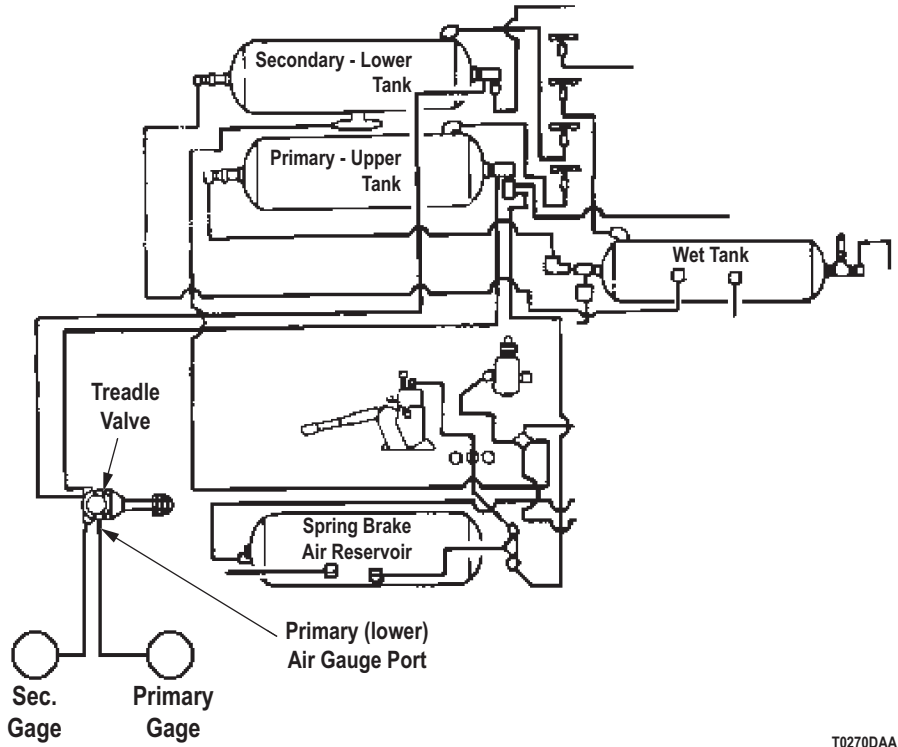

T0270DAA

Figure 1. Air Supply System.

- b. Listen for leaking air lines or fittings. Refer to point to point schematics.

CONDITION/INDICATION

ARE AIR LINES OR FITTINGS LEAKING?

DECISION

- YES - Tighten fittings or replace damaged air lines (Volume 5, WP 0805). Go to Step (7) to verify problem is solved.
- NO - Go to Step (2).

PRIMARY PRESSURE GAUGE READS NO PRESSURE, LOW PRESSURE, OR BUILDS TO NORMAL OPERATING PRESSURE SLOWLY. SECONDARY PRESSURE GAUGE READS NORMAL (ENGINE IDLING, BRAKE PEDAL NOT APPLIED) - Continued

STEP

2. IS PRIMARY AIR PRESSURE GAUGE OPERATING PROPERLY?
 - a. Stop engine and open all draincocks until brake system air pressure is vented.
 - b. Close draincocks.

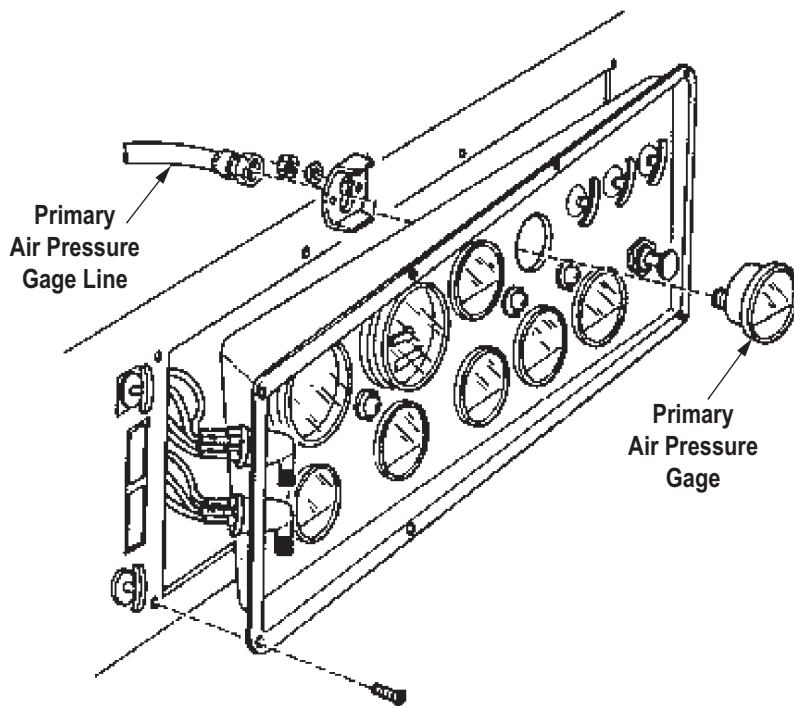

T0888DAA

Figure 2. Primary Air Pressure Gauge.

- c. Disconnect air line from primary air pressure gauge. Refer to point to point schematics.
- d. Connect pressure gauge to disconnected air line.
- e. Start engine.
- f. Monitor air pressure on pressure gauge.
- g. If pressure gauge reads 90 psi after 5 minutes, primary air pressure gauge is not operating properly.

CONDITION/INDICATION

IS PRIMARY AIR PRESSURE GAUGE OPERATING PROPERLY?

DECISION

NO - Replace defective primary air pressure gauge (Volume 5, WP 0818). Go to Step (7) to verify problem is solved.

YES - Go to Step (3).

PRIMARY PRESSURE GAUGE READS NO PRESSURE, LOW PRESSURE, OR BUILDS TO NORMAL OPERATING PRESSURE SLOWLY. SECONDARY PRESSURE GAUGE READS NORMAL (ENGINE IDLING, BRAKE PEDAL NOT APPLIED) - Continued

STEP

3. IS THERE PROPER AIR PRESSURE AT BRAKE PEDAL VALVE SUPPLY PORT?
 - a. Stop engine and open all draincocks until brake system air pressure is vented.
 - b. Close draincocks.

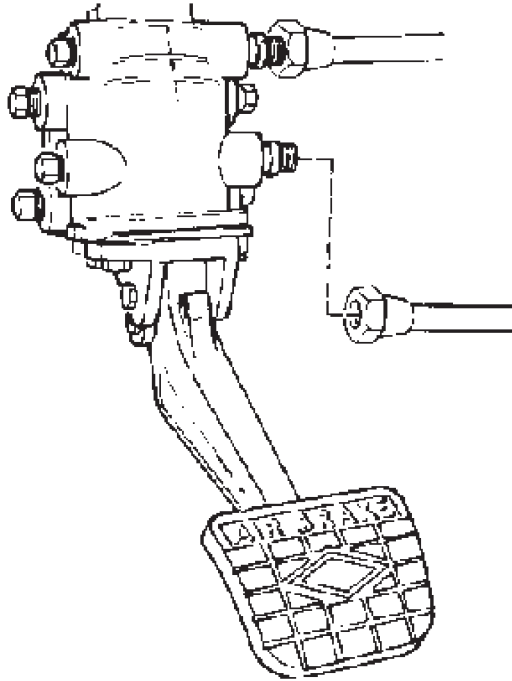

T0272DAA

Figure 3. Brake Pedal.

- c. Disconnect primary pressure gauge air line from pedal valve. Refer to point to point schematics.
- d. Connect adapter fitting to pedal valve and move pressure gauge from disconnected air line to adapter fitting.
- e. Start engine.
- f. Monitor air pressure on pressure gauge.
- g. After 5 minutes pressure gauge should be read 90 psi.

CONDITION/INDICATION

IS THERE PROPER AIR PRESSURE AT BRAKE PEDAL VALVE SUPPLY PORT?

DECISION

NO - Go to Step (4).

YES - Replace damaged air lines (Volume 5, WP 0805). Go to Step (7) to verify problem is solved.

PRIMARY PRESSURE GAUGE READS NO PRESSURE, LOW PRESSURE, OR BUILDS TO NORMAL OPERATING PRESSURE SLOWLY. SECONDARY PRESSURE GAUGE READS NORMAL (ENGINE IDLING, BRAKE PEDAL NOT APPLIED) - Continued

STEP

4. DOES PRIMARY AIR RESERVOIR HAVE CORRECT AIR PRESSURE?
 - a. Stop engine and open all draincocks until brake system air pressure is vented.
 - b. Close draincocks.
 - c. Disconnect pressure gauge from vehicle.
 - d. Reconnect both ends of primary air pressure gauge air line.

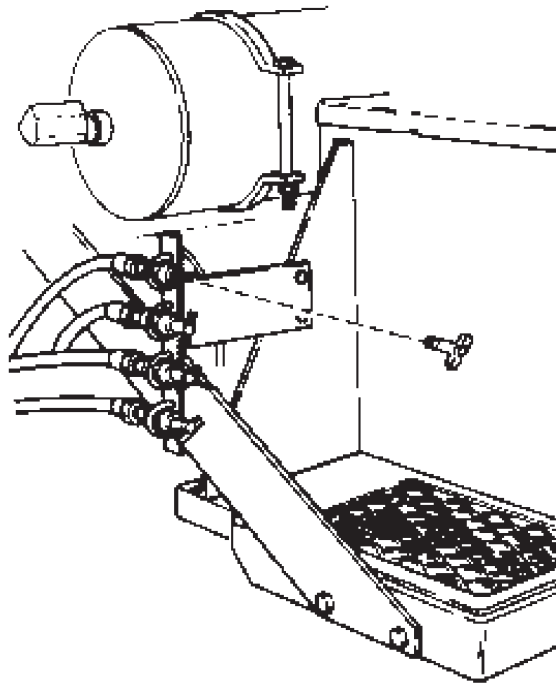

T0273DAA

Figure 4. Primary Air Reservoir Drain Line.

- e. Disconnect draincock from drain line. Refer to point to point schematics.
- f. Connect adapter fitting to drain line and pressure gauge to fitting.
- g. Start engine.
- h. Monitor air pressure on pressure gauge.
- i. After 5 minutes pressure gauge should be read 90 psi.

CONDITION/INDICATION

DOES PRIMARY AIR RESERVOIR HAVE CORRECT AIR PRESSURE?

DECISION

- NO - Go to Step (6).
 YES - Go to Step (5).

PRIMARY PRESSURE GAUGE READS NO PRESSURE, LOW PRESSURE, OR BUILDS TO NORMAL OPERATING PRESSURE SLOWLY. SECONDARY PRESSURE GAUGE READS NORMAL (ENGINE IDLING, BRAKE PEDAL NOT APPLIED) - Continued

STEP

5. IS THERE PROPER AIR PRESSURE AT BRAKE PEDAL VALVE?
 - a. Stop engine and open all draincocks until brake system air pressure is vented.
 - b. Close draincocks.

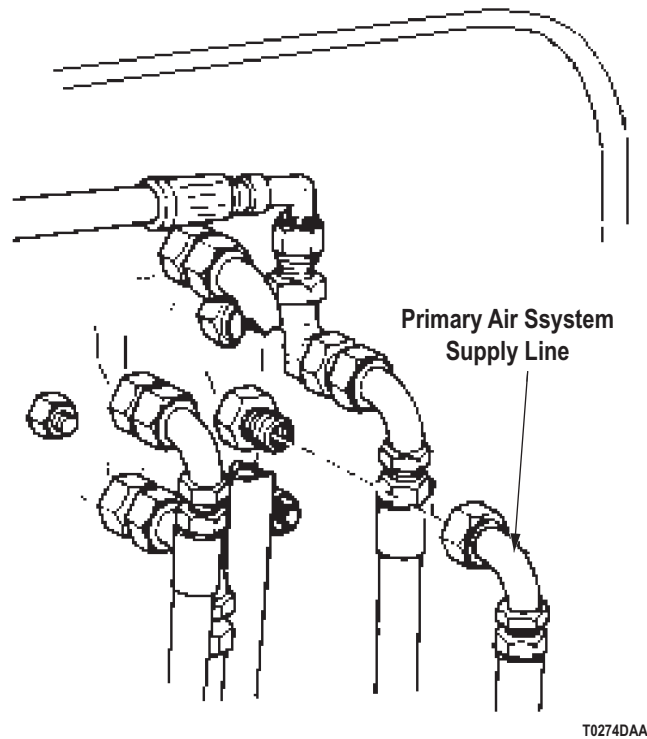

T0274DAA

Figure 5. Primary Air System Supply Line.

- c. Disconnect pressure gauge from vehicle return air line to original condition.
- d. Disconnect primary air system supply line from brake pedal valve fitting. Refer to point to point schematics.
- e. Connect pressure gauge to primary supply line.
- f. Start engine.
- g. Monitor air pressure on pressure gauge.
- h. After 5 minutes pressure gauge should be read 90 psi.

CONDITION/INDICATION

IS THERE PROPER AIR PRESSURE AT BRAKE PEDAL VALVE?

DECISION

NO - Go to Step (6).

PRIMARY PRESSURE GAUGE READS NO PRESSURE, LOW PRESSURE, OR BUILDS TO NORMAL OPERATING PRESSURE SLOWLY. SECONDARY PRESSURE GAUGE READS NORMAL (ENGINE IDLING, BRAKE PEDAL NOT APPLIED) - Continued

YES - Replace defective brake pedal valve (Volume 3, WP 0428), M936 (Volume 3, WP 0429). Go to Step (7) to verify problem is solved.

STEP

6. IS ONE-WAY CHECK VALVE IN GOOD OPERATING CONDITION?
 - a. Stop engine and open all draincocks until brake system is vented.
 - b. Disconnect pressure gauge from vehicle return air line to original condition.

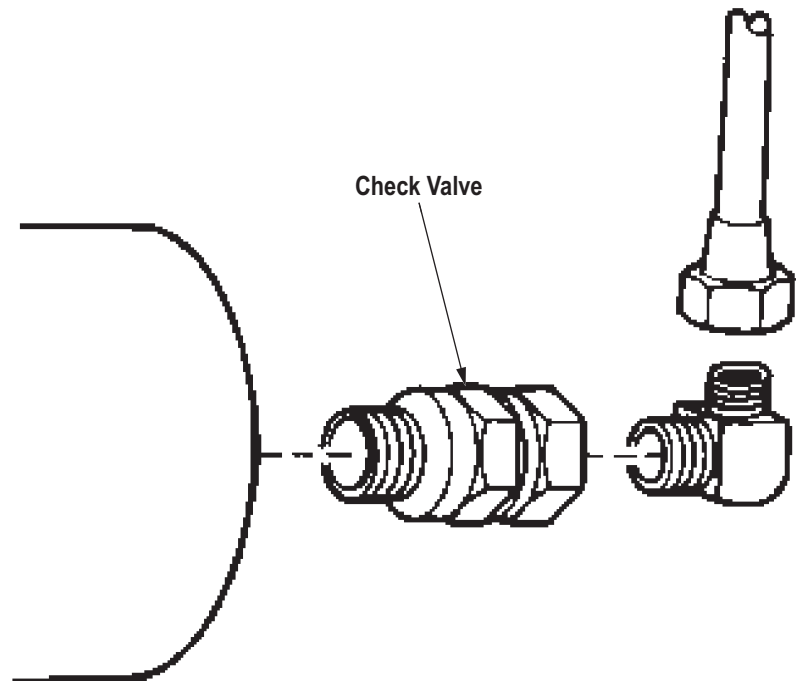

T0275DAA

Figure 6. One-Way Check Valve.

- c. Remove one-way check valve.
- d. Inspect check valve for clogging and damage.

CONDITION/INDICATION

IS ONE-WAY CHECK VALVE IN GOOD OPERATING CONDITION?

DECISION

NO - Replace defective one-way check valve (Volume 3, WP 0437). Go to Step (7) to verify problem is solved.
 YES - Notify supervisor. Action may not be possible at this level of maintenance.

PRIMARY PRESSURE GAUGE READS NO PRESSURE, LOW PRESSURE, OR BUILDS TO NORMAL OPERATING PRESSURE SLOWLY. SECONDARY PRESSURE GAUGE READS NORMAL (ENGINE IDLING, BRAKE PEDAL NOT APPLIED) - Continued

STEP

7. IS YOUR ORIGINAL AIR PRESSURE PROBLEM STILL PRESENT?
 - a. Ensure vehicle is returned to normal operating condition.
 - b. Check to see if your original problem still exists.

CONDITION/INDICATION

IS YOUR ORIGINAL AIR PRESSURE PROBLEM STILL PRESENT?

DECISION

YES - Notify supervisor.
NO - Problem fixed.

END OF WORK PACKAGE

FIELD MAINTENANCE
SECONDARY PRESSURE GAUGE READS NO PRESSURE, LOW PRESSURE, OR BUILDS TO NORMAL
OPERATING PRESSURE SLOWLY. PRIMARY PRESSURE GAUGE READS NORMAL (ENGINE IDLING,
BRAKE PEDAL NOT APPLIED)

INITIAL SETUP:**Tools and Special Tools**

Tool Kit, General Mechanic's: Automotive
 (Volume 5, WP 0826, Table 1, Item 56)
 Gauge, Pressure
 (Volume 5, WP 0826, Table 1, Item 19)
 Test Set, Electronic Systems
 (Volume 5, WP 0826, Table 1, Item 51)

References (cont.)

Volume 3, WP 0428
 Volume 3, WP 0429
 Volume 3, WP 0430
 Volume 5, WP 0805
 Volume 5, WP 0818

Personnel Required

(2)

Equipment Condition

Vehicle parked and engine shut down.
 (TM 9-2320-272-10)

References

Point to Point Schematics

TROUBLESHOOTING PROCEDURE

SECONDARY PRESSURE GAUGE READS NO PRESSURE, LOW PRESSURE, OR BUILDS TO NORMAL
OPERATING PRESSURE SLOWLY. PRIMARY PRESSURE GAUGE READS NORMAL (ENGINE IDLING,
BRAKE PEDAL NOT APPLIED)

NOTE

Conduct these malfunction tests if secondary air pressure gauge reads no pressure, low pressure or builds slowly to normal operating pressure, primary air pressure gauge reads normal. This procedure will check for air leaks from lines or fittings, faulty secondary air pressure gauge, clogged air supply lines, faulty brake pedal valve, and one-way check valve.

SECONDARY PRESSURE GAUGE READS NO PRESSURE, LOW PRESSURE, OR BUILDS TO NORMAL OPERATING PRESSURE SLOWLY. PRIMARY PRESSURE GAUGE READS NORMAL (ENGINE IDLING, BRAKE PEDAL NOT APPLIED) - Continued

STEP

1. ARE AIR LINES OR FITTINGS LEAKING?
 - a. Start engine.

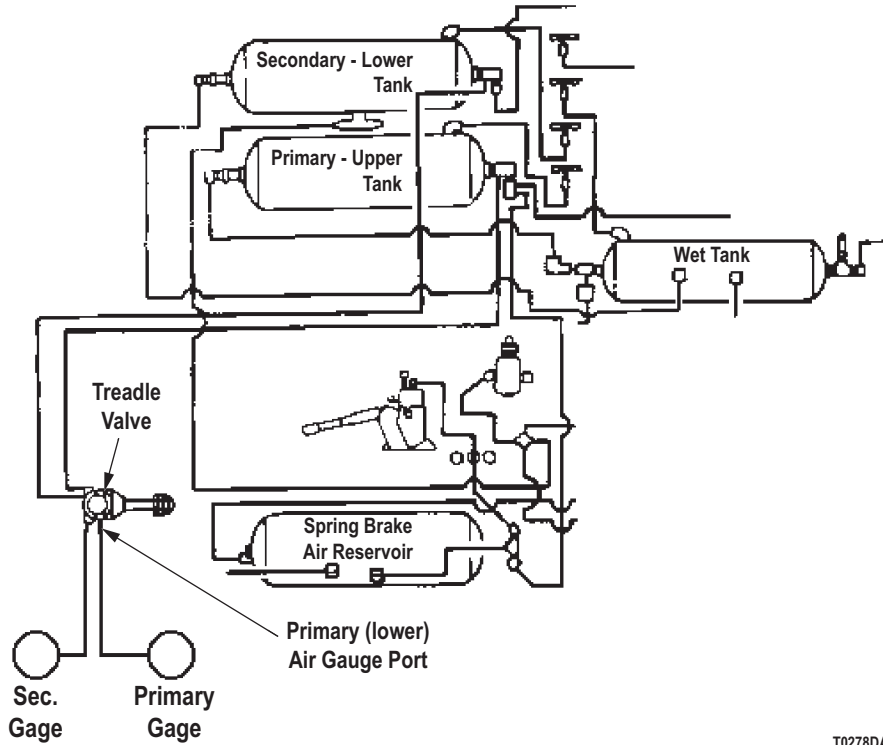

T0278DAA

Figure 1. Air Supply System.

- b. Listen for leaking air lines or fittings. Refer to point to point schematics.

CONDITION/INDICATION

ARE AIR LINES OR FITTINGS LEAKING?

DECISION

- YES - Tighten fittings or replace damaged air lines (Volume 5, WP 0805). Go to Step (7) to verify problem is solved.
- NO - Go to Step (2).

SECONDARY PRESSURE GAUGE READS NO PRESSURE, LOW PRESSURE, OR BUILDS TO NORMAL OPERATING PRESSURE SLOWLY. PRIMARY PRESSURE GAUGE READS NORMAL (ENGINE IDLING, BRAKE PEDAL NOT APPLIED) - Continued

STEP

2. IS SECONDARY AIR PRESSURE GAUGE OPERATING PROPERLY?
 - a. Stop engine and open all draincocks until brake system air pressure is vented.
 - b. Close draincocks.

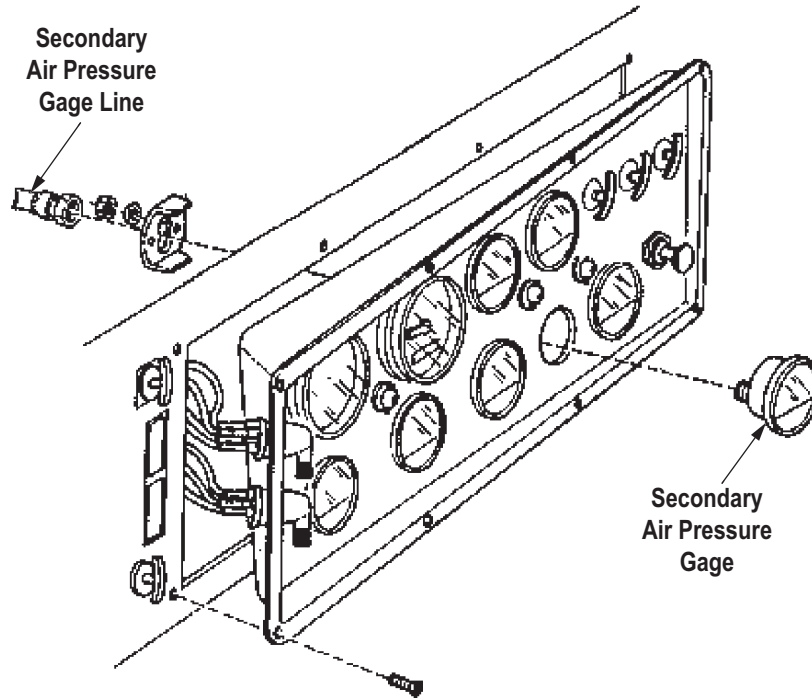

T0279DAA

Figure 2. Secondary Air Pressure Gauge.

- c. Disconnect air line from secondary air pressure gauge. Refer to point to point schematics.
- d. Connect pressure gauge to disconnected air line.
- e. Start engine.
- f. Monitor air pressure on pressure gauge.
- g. If pressure gauge reads 90 psi after 5 minutes, secondary air pressure gauge is not operating properly.

CONDITION/INDICATION

IS SECONDARY AIR PRESSURE GAUGE OPERATING PROPERLY?

DECISION

NO - Replace defective secondary air pressure gauge (Volume 5, WP 0818). Go to Step (7) to verify problem is solved.
 YES - Go to Step (3).

SECONDARY PRESSURE GAUGE READS NO PRESSURE, LOW PRESSURE, OR BUILDS TO NORMAL OPERATING PRESSURE SLOWLY. PRIMARY PRESSURE GAUGE READS NORMAL (ENGINE IDLING, BRAKE PEDAL NOT APPLIED) - Continued

STEP

3. IS THERE PROPER AIR PRESSURE AT BRAKE PEDAL VALVE SUPPLY PORT?
 - a. Stop engine and open all draincocks until brake system air pressure is vented.
 - b. Close draincocks.

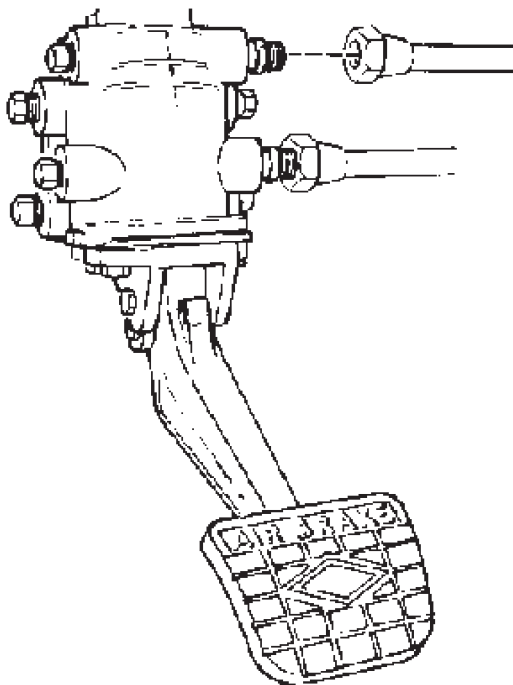

T0280DAA

Figure 3. Brake Pedal.

SECONDARY PRESSURE GAUGE READS NO PRESSURE, LOW PRESSURE, OR BUILDS TO NORMAL OPERATING PRESSURE SLOWLY. PRIMARY PRESSURE GAUGE READS NORMAL (ENGINE IDLING, BRAKE PEDAL NOT APPLIED) - Continued

- c. Disconnect secondary pressure gauge air line from pedal valve. Refer to point to point schematics.
- d. Connect adapter fitting to pedal valve and move pressure gauge from disconnected air line to adapter fitting.
- e. Start engine.
- f. Monitor air pressure on pressure gauge.
- g. After 5 minutes pressure gauge should be read 90 psi.

CONDITION/INDICATION

IS THERE PROPER AIR PRESSURE AT BRAKE PEDAL VALVE SUPPLY PORT?

DECISION

NO - Go to Step (4).

YES - Replace damaged air lines (Volume 5, WP 0805). Go to Step (7) to verify problem is solved.

SECONDARY PRESSURE GAUGE READS NO PRESSURE, LOW PRESSURE, OR BUILDS TO NORMAL OPERATING PRESSURE SLOWLY. PRIMARY PRESSURE GAUGE READS NORMAL (ENGINE IDLING, BRAKE PEDAL NOT APPLIED) - Continued

STEP

4. DOES SECONDARY AIR RESERVOIR HAVE CORRECT AIR PRESSURE?
 - a. Stop engine and open all draincocks until brake system air pressure is vented.
 - b. Close draincocks.

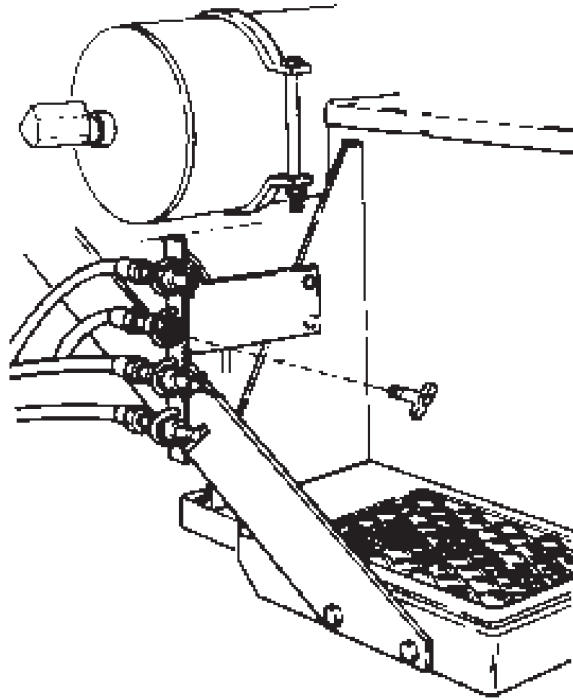

T0281DAA

Figure 4. Secondary Air Reservoir Drain Line.

SECONDARY PRESSURE GAUGE READS NO PRESSURE, LOW PRESSURE, OR BUILDS TO NORMAL OPERATING PRESSURE SLOWLY. PRIMARY PRESSURE GAUGE READS NORMAL (ENGINE IDLING, BRAKE PEDAL NOT APPLIED) - Continued

- c. Disconnect pressure gauge from vehicle.
- d. Reconnect both ends of secondary air pressure gauge air line.
- e. Disconnect draincock from drain line. Refer to point to point schematics.
- f. Connect adapter fitting to drain line and pressure gauge to fitting.
- g. Start engine.
- h. Monitor air pressure on pressure gauge.
- i. After 5 minutes pressure gauge should be read 90 psi.

CONDITION/INDICATION

DOES SECONDARY AIR RESERVOIR HAVE CORRECT AIR PRESSURE?

DECISION

NO - Go to Step (6).
YES - Go to Step (5).

SECONDARY PRESSURE GAUGE READS NO PRESSURE, LOW PRESSURE, OR BUILDS TO NORMAL OPERATING PRESSURE SLOWLY. PRIMARY PRESSURE GAUGE READS NORMAL (ENGINE IDLING, BRAKE PEDAL NOT APPLIED) - Continued

STEP

5. IS THERE PROPER AIR PRESSURE AT BRAKE PEDAL VALVE?
 - a. Stop engine and open all draincocks until brake system air pressure is vented.
 - b. Close draincocks.

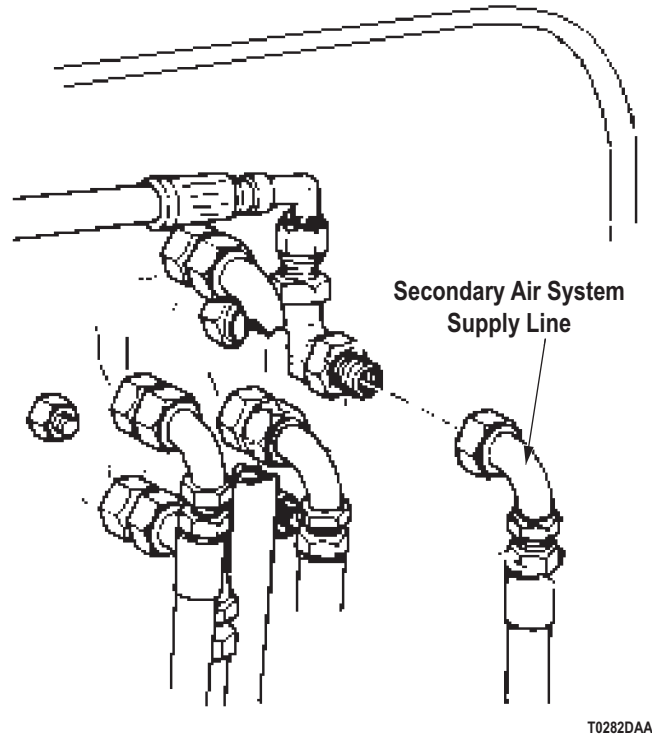

T0282DAA

Figure 5. Secondary Air System Supply Line.

- c. Disconnect pressure gauge from vehicle return air line to original condition.
- d. Disconnect secondary air system supply line from brake pedal valve fitting. Refer to point to point schematics.
- e. Connect pressure gauge to secondary supply line.
- f. Start engine.
- g. Monitor air pressure on pressure gauge.
- h. After 5 minutes pressure gauge should be read 90 psi.

CONDITION/INDICATION

IS THERE PROPER AIR PRESSURE AT BRAKE PEDAL VALVE?

DECISION

NO - Go to Step (6).

SECONDARY PRESSURE GAUGE READS NO PRESSURE, LOW PRESSURE, OR BUILDS TO NORMAL OPERATING PRESSURE SLOWLY. PRIMARY PRESSURE GAUGE READS NORMAL (ENGINE IDLING, BRAKE PEDAL NOT APPLIED) - Continued

YES - Replace defective brake pedal valve (Volume 3, WP 0429), M936 (Volume 3, WP 0430). Go to Step (7) to verify problem is solved.

STEP

6. IS ONE-WAY CHECK VALVE IN GOOD OPERATING CONDITION?
 - a. Stop engine and open all draincocks until brake system is vented.
 - b. Disconnect pressure gauge from vehicle return air line to original condition.

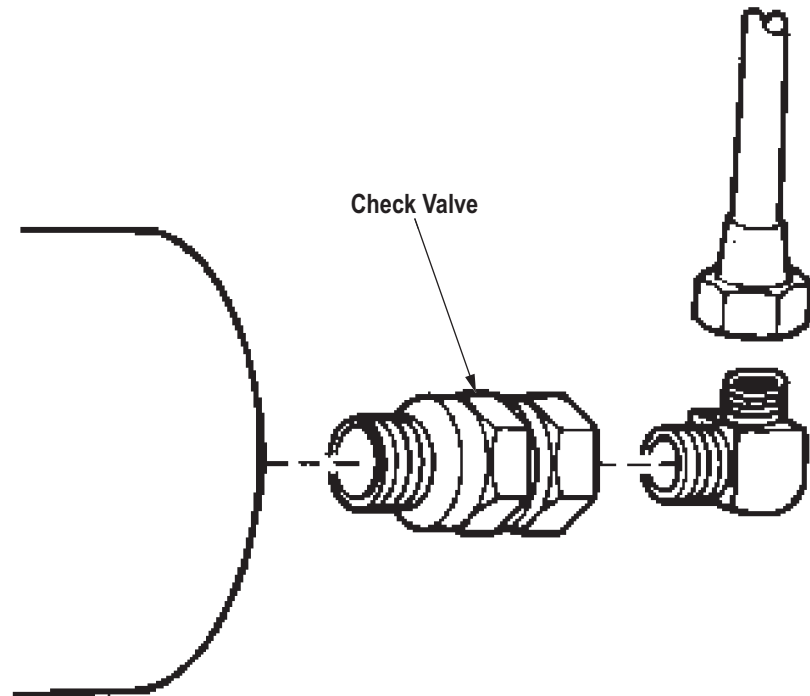

Figure 6. One-Way Check Valve.

- c. Remove one-way check valve.
- d. Inspect check valve for clogging and damage.

CONDITION/INDICATION

IS ONE-WAY CHECK VALVE IN GOOD OPERATING CONDITION?

DECISION

NO - Replace defective one-way check valve (Volume 3, WP 0437). Go to Step (7) to verify problem is solved.
 YES - Notify supervisor. Action may not be possible at this level of maintenance.

SECONDARY PRESSURE GAUGE READS NO PRESSURE, LOW PRESSURE, OR BUILDS TO NORMAL OPERATING PRESSURE SLOWLY. PRIMARY PRESSURE GAUGE READS NORMAL (ENGINE IDLING, BRAKE PEDAL NOT APPLIED) - Continued

STEP

7. IS YOUR ORIGINAL AIR PRESSURE PROBLEM STILL PRESENT?
 - a. Ensure vehicle is returned to normal operating condition.
 - b. Check to see if your original problem still exists.

CONDITION/INDICATION

IS YOUR ORIGINAL AIR PRESSURE PROBLEM STILL PRESENT?

DECISION

YES - Notify supervisor.
NO - Problem fixed.

END OF WORK PACKAGE

FIELD MAINTENANCE
PRIMARY AIR SYSTEM FAILS TO MAINTAIN PRESSURE (NO MAJOR LEAKS, AIR CAN BE HEARD ESCAPING INTO AIR INTAKE STACK, PARKING BRAKE APPLIED)

INITIAL SETUP:**Tools and Special Tools**

Tool Kit, General Mechanic's: Automotive
(Volume 5, WP 0826, Table 1, Item 56)
Test Set, Electronic Systems
(Volume 5, WP 0826, Table 1, Item 51)

Personnel Required

(2)

References

Point to Point Schematics
Volume 3, WP 0434

Equipment Condition

Vehicle parked and engine shut down.
(TM 9-2320-272-10)

TROUBLESHOOTING PROCEDURE**PRIMARY AIR SYSTEM FAILS TO MAINTAIN PRESSURE (NO MAJOR LEAKS, AIR CAN BE HEARD ESCAPING INTO AIR INTAKE STACK, PARKING BRAKE APPLIED)****NOTE**

Conduct these malfunction tests if primary air pressure system fails to hold pressure. No major leaks, air can be heard escaping into air intake stack, parking brake applied. This procedure will check for air leaks through vent lines.

PRIMARY AIR SYSTEM FAILS TO MAINTAIN PRESSURE (NO MAJOR LEAKS, AIR CAN BE HEARD ESCAPING INTO AIR INTAKE STACK, PARKING BRAKE APPLIED) - Continued

STEP

1. DOES AIR LEAK THROUGH SERVICE BRAKE CHAMBER VENT LINES?

- a. Disconnect vent line from right front service brake chamber (Volume 3, WP 0434). Refer to point to point schematics.

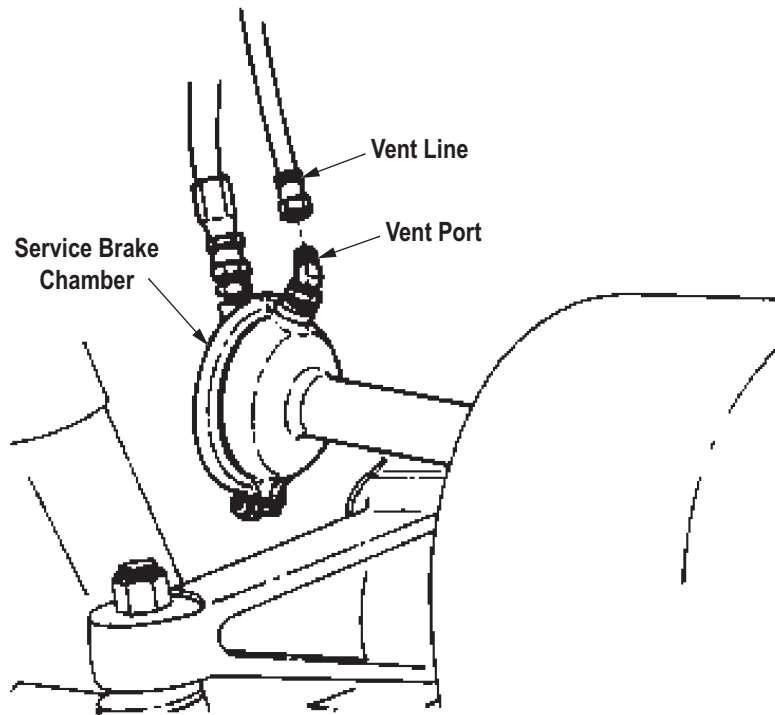

T0884DAA

Figure 1. Service Brake Chamber Vent Line.

WARNING

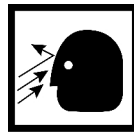

Do not look in service chamber vent port when performing test. Failure to comply may result in injury or death to personnel.

- b. Assistant applies service brakes and feels for evidence of escaping air at vent port.
- c. Connect vent line to service brake chamber.
- d. Check vent lines on all service brake chambers. Note any chambers that leak air.

CONDITION/INDICATION

DOES AIR LEAK THROUGH SERVICE BRAKE CHAMBER VENT LINES?

PRIMARY AIR SYSTEM FAILS TO MAINTAIN PRESSURE (NO MAJOR LEAKS, AIR CAN BE HEARD ESCAPING INTO AIR INTAKE STACK, PARKING BRAKE APPLIED) - Continued

DECISION

YES - Replace faulty brake chamber (Volume 3, WP 0434). Go to Step (2) to verify problem is solved.
NO - Go to Step (2) to verify problem is solved.

STEP

2. IS YOUR ORIGINAL AIR PRESSURE PROBLEM STILL PRESENT?
 - a. Ensure vehicle is returned to normal operating condition.
 - b. Check to see if your original air pressure problem still exists.

CONDITION/INDICATION

IS YOUR ORIGINAL AIR PRESSURE PROBLEM STILL PRESENT?

DECISION

YES - Notify supervisor.
NO - Problem fixed.

END OF WORK PACKAGE

FIELD MAINTENANCE
SECONDARY AIR SYSTEM FAILS TO MAINTAIN PRESSURE (NO MAJOR LEAKS, AIR CAN BE HEARD ESCAPING INTO AIR INTAKE STACK, PARKING BRAKE APPLIED)

INITIAL SETUP:**Tools and Special Tools**

Tool Kit, General Mechanic's: Automotive
(Volume 5, WP 0826, Table 1, Item 56)
Gauge, Pressure
(Volume 5, WP 0826, Table 1, Item 19)
Test Set, Electronic Systems
(Volume 5, WP 0826, Table 1, Item 51)

References (cont.)

Volume 3, WP 0429
Volume 3, WP 0430
Volume 3, WP 0457
Volume 5, WP 0805

Personnel Required

(2)

Equipment Condition

Vehicle parked and engine shut down.
(TM 9-2320-272-10)

References

Point to Point Schematics

TROUBLESHOOTING PROCEDURE**SECONDARY AIR SYSTEM FAILS TO MAINTAIN PRESSURE (NO MAJOR LEAKS, AIR CAN BE HEARD ESCAPING INTO AIR INTAKE STACK, PARKING BRAKE APPLIED)****NOTE**

Conduct these malfunction tests if secondary air pressure system fails to hold pressure. No major leaks, air can be heard escaping into air intake stack, parking brake applied. This procedure will check for blocked secondary air system relay valve and secondary air pressure gauge delivery lines.

SECONDARY AIR SYSTEM FAILS TO MAINTAIN PRESSURE (NO MAJOR LEAKS, AIR CAN BE HEARD ESCAPING INTO AIR INTAKE STACK, PARKING BRAKE APPLIED) - Continued

STEP

1. IS PROPER AIR PRESSURE AT SECONDARY RELAY VALVE?
 - a. Stop engine and open all draincocks until brake system air pressure is vented.
 - b. Close all draincocks.

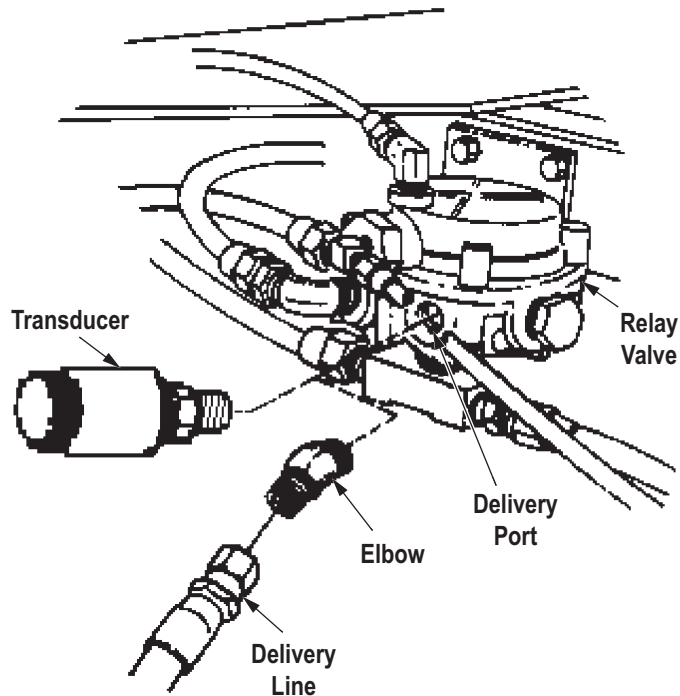

T0286DAA

Figure 1. Secondary Relay Valve Delivery Port.

- c. Disconnect air line from elbow at secondary relay valve delivery port (Volume 3, WP 0457). Refer to point to point schematics.
- d. Remove elbow from secondary relay valve delivery port.
- e. Connect pressure gauge to disconnected relay valve delivery port.
- f. Assistant starts engine and runs to build air supply to normal operating pressure.
- g. Assistant fully applies and holds service brakes.
- h. Monitor air pressure on pressure gauge.
- i. After 5 minutes, pressure gauge should read 90 to 130 psi.

SECONDARY AIR SYSTEM FAILS TO MAINTAIN PRESSURE (NO MAJOR LEAKS, AIR CAN BE HEARD ESCAPING INTO AIR INTAKE STACK, PARKING BRAKE APPLIED) - Continued

CONDITION/INDICATION

IS PROPER AIR PRESSURE AT SECONDARY RELAY VALVE?

DECISION

NO - Go to Step (2).

YES - Replace damaged air lines from secondary relay valve to rear brake chambers (Volume 5, WP 0805).

Go to Step (4) to verify problem is solved.

SECONDARY AIR SYSTEM FAILS TO MAINTAIN PRESSURE (NO MAJOR LEAKS, AIR CAN BE HEARD ESCAPING INTO AIR INTAKE STACK, PARKING BRAKE APPLIED) - Continued

STEP

2. IS PROPER AIR PRESSURE AT SECONDARY RELAY VALVE?
 - a. Stop engine and open all draincocks until brake system air pressure is vented.
 - b. Close all draincocks.
 - c. Disconnect pressure gauge from vehicle and return air line to original condition.

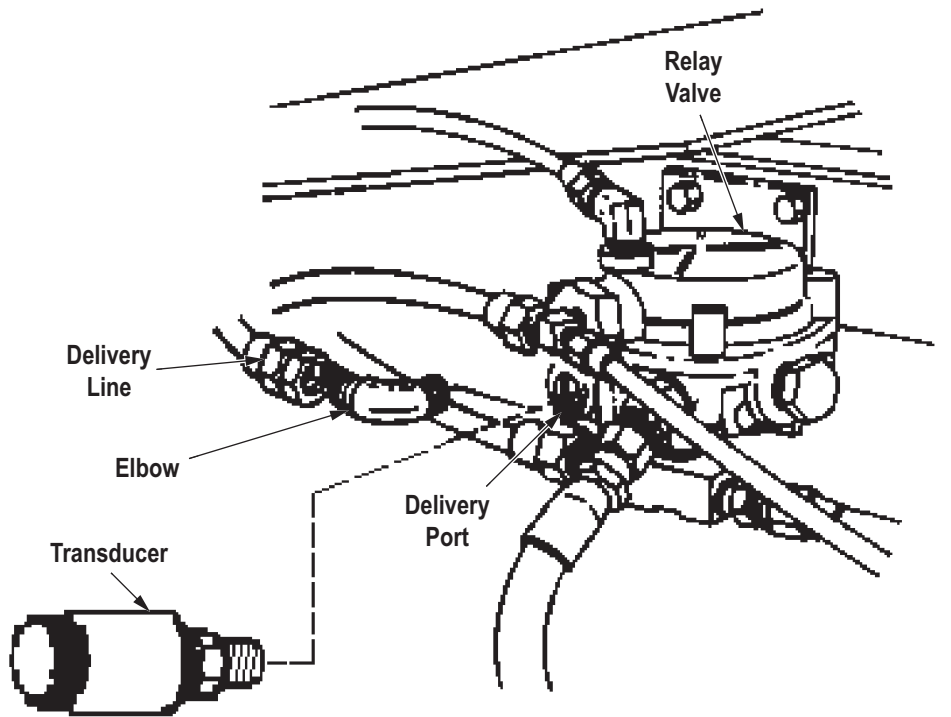

T0289DAA

Figure 2. Secondary Relay Valve Delivery Port.

- d. Disconnect air line from elbow at secondary relay valve delivery port (Volume 3, WP 0457). Refer to point to point schematics.
- e. Remove elbow from secondary relay valve delivery port.
- f. Connect pressure gauge to disconnected relay valve delivery port.
- g. Assistant starts engine and runs to build air supply to normal operating pressure.
- h. Assistant fully applies and holds service brakes.
- i. Monitor air pressure on pressure gauge.
- j. After 5 minutes, pressure gauge should read 90 to 130 psi.

SECONDARY AIR SYSTEM FAILS TO MAINTAIN PRESSURE (NO MAJOR LEAKS, AIR CAN BE HEARD ESCAPING INTO AIR INTAKE STACK, PARKING BRAKE APPLIED) - Continued

CONDITION/INDICATION

IS PROPER AIR PRESSURE AT SECONDARY RELAY VALVE?

DECISION

NO - Go to Step (3).

YES - Replace damaged air lines from secondary relay valve to rear brake chambers (Volume 5, WP 0805).

Go to Step (4) to verify problem is solved.

SECONDARY AIR SYSTEM FAILS TO MAINTAIN PRESSURE (NO MAJOR LEAKS, AIR CAN BE HEARD ESCAPING INTO AIR INTAKE STACK, PARKING BRAKE APPLIED) - Continued

STEP

3. IS PROPER AIR PRESSURE AT SERVICE BRAKE PEDAL VALVE SECONDARY AIR SYSTEM DELIVERY PORT?
 - a. Stop engine and open all draincocks until brake system air pressure is vented.
 - b. Close all draincocks.
 - c. Disconnect pressure gauge from vehicle and return air line to original condition.

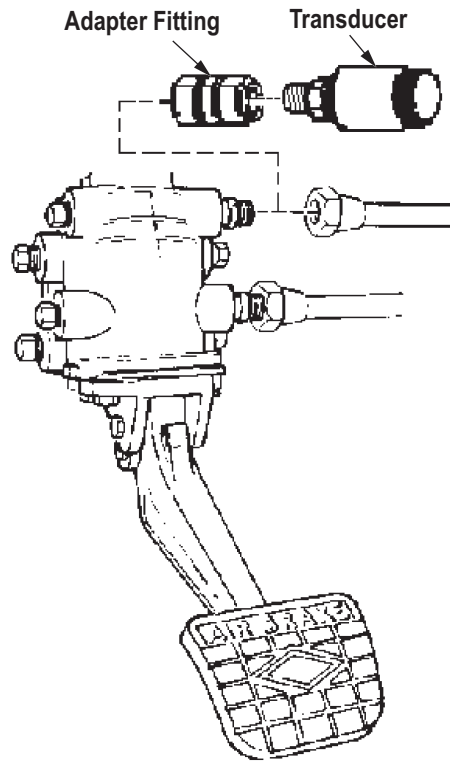

T0291DAA

Figure 3. Service Brake Pedal Valve.

- d. Disconnect secondary pressure gauge air line from pedal valve.
- e. Connect adapter fitting to pedal valve.
- f. Connect pressure gauge to adapter fitting.
- g. Starts engine.
- h. Monitor air pressure on pressure gauge.
- i. After 5 minutes, pressure gauge should read 90 to 130 psi.

SECONDARY AIR SYSTEM FAILS TO MAINTAIN PRESSURE (NO MAJOR LEAKS, AIR CAN BE HEARD ESCAPING INTO AIR INTAKE STACK, PARKING BRAKE APPLIED) - Continued**CONDITION/INDICATION**

IS PROPER AIR PRESSURE AT SERVICE BRAKE PEDAL VALVE SECONDARY AIR SYSTEM DELIVERY PORT?

DECISION

NO - Go to Step (4) to verify problem is solved.

YES - Replace service brake pedal valve (Volume 3, WP 0429), M936 (Volume 3, WP 0430). Go to Step (4) to verify problem is solved.

STEP

4. IS YOUR ORIGINAL AIR PRESSURE PROBLEM STILL PRESENT?
 - a. Ensure vehicle is returned to normal operating condition.
 - b. Check to see if your original air pressure problem still exists.

CONDITION/INDICATION

IS YOUR ORIGINAL AIR PRESSURE PROBLEM STILL PRESENT?

DECISION

YES - Notify supervisor.

NO - Problem fixed.

END OF WORK PACKAGE

FIELD MAINTENANCE
WARNING BUZZER FAILS TO SOUND OR FAILS TO SHUT OFF ON LOW PRESSURE (BELOW 55-65 PSI [379-448 KPA]), AIR PRESSURE SYSTEM OPERATING NORMALLY

INITIAL SETUP:**References**

WP 0110

Equipment ConditionVehicle parked and engine shut down.
(TM 9-2320-272-10)

TROUBLESHOOTING PROCEDURE

WARNING BUZZER FAILS TO SOUND OR FAILS TO SHUT OFF ON LOW PRESSURE (BELOW 55-65 PSI [379-448 KPA]), AIR PRESSURE SYSTEM OPERATING NORMALLY

STEP**NOTE**

This procedure is located in the electrical troubleshooting section.

1. Perform Warning Buzzer Fails To Sound or Fails To Shut Off on Low Pressure troubleshooting (WP 0110).

CONDITION/INDICATION**DECISION****END OF WORK PACKAGE**

FIELD MAINTENANCE
SPRING BRAKES DO NOT RELEASE (VEHICLE BRAKES GRAB OR DRAG)

INITIAL SETUP:**Tools and Special Tools**

Tool Kit, General Mechanic's: Automotive
(Volume 5, WP 0826, Table 1, Item 56)
Test Set, Electronic Systems
(Volume 5, WP 0826, Table 1, Item 51)

References (cont.)

WP 0122
Volume 3, WP 0431
Volume 3, WP 0477
Volume 5, WP 0805

Personnel Required

(2)

Equipment Condition

Vehicle parked and engine shut down.
(TM 9-2320-272-10)

References

Point to Point Schematics

TROUBLESHOOTING PROCEDURE**SPRING BRAKES DO NOT RELEASE (VEHICLE BRAKES GRAB OR DRAG)****NOTE**

Conduct these malfunction tests if the spring brakes do not release. This procedure will check for oil needed at mechanical actuator, defective quick release valve, defective double-check valve, clogged or faulty air line between quick-release valve and double-check valve, defective parking brake valve, and defective spring brake diaphragms.

SPRING BRAKES DO NOT RELEASE (VEHICLE BRAKES GRAB OR DRAG) - Continued**STEP****1. CAN SPRING BRAKES BE RELEASED?**

- a. Assistant starts engine and builds air supply to normal operating pressure.

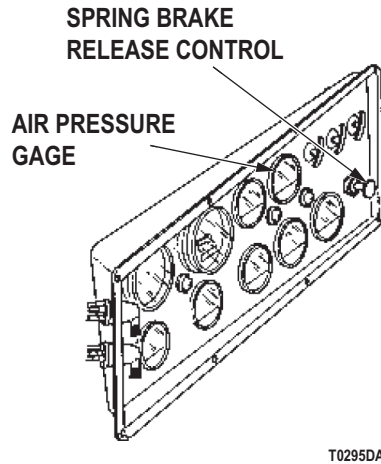

Figure 1. Spring Brake Release Control.

- b. Assistant pulls out emergency spring brake release control and moves vehicle forward.
- c. Watch to see if any wheels with spring brakes do not turn.

CONDITION/INDICATION

CAN SPRING BRAKES BE RELEASED?

DECISION

- NO - Only one wheel is not turning. Perform Vehicle Rear Brakes Grab Or Drag troubleshooting (WP 0122).
 NO - No wheels with spring brakes turn. Go to Step (5).
 YES - All wheels turn. Go to Step (2).

SPRING BRAKES DO NOT RELEASE (VEHICLE BRAKES GRAB OR DRAG) - Continued**STEP**

2. IS PARKING BRAKE VALVE MECHANICAL ACTUATOR STUCK IN ENGAGED POSITION?
 - a. Turn off engine.
 - b. Verify parking brake is released, then move mechanical actuator by hand to check for sticking.

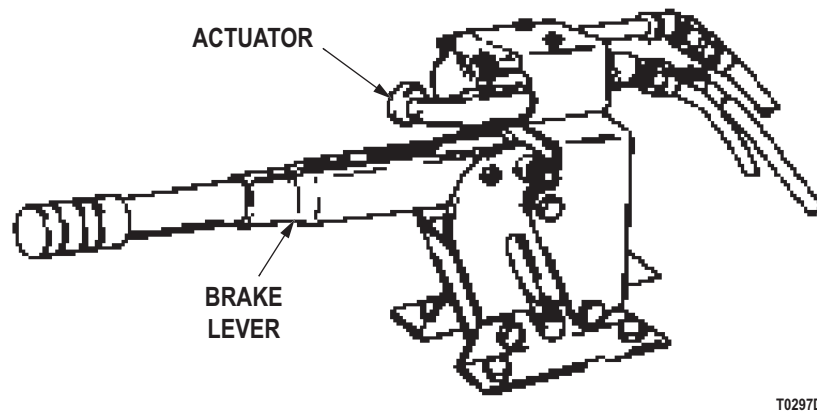

Figure 2. Parking Brake Control Lever.

CONDITION/INDICATION

IS PARKING BRAKE VALVE MECHANICAL ACTUATOR STUCK IN ENGAGED POSITION?

DECISION

- NO - Go to Step (4).
YES - Go to Step (3).

SPRING BRAKES DO NOT RELEASE (VEHICLE BRAKES GRAB OR DRAG) - Continued**STEP**

3. DOES OIL ON PARKING BRAKE VALVE MECHANICAL ACTUATOR CAUSE IT TO MOVE FREELY?
 - a. Pull back rubber boot.

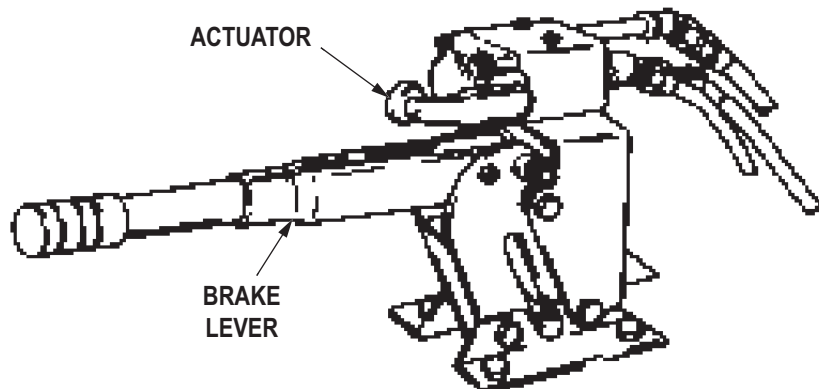

T0297DAA

Figure 3. Parking Brake Control Lever.

- b. Apply a few drops of light machine oil to the parking brake valve mechanical actuator.
 - c. Move mechanical actuator by hand to check for sticking.

CONDITION/INDICATION

DOES OIL ON PARKING BRAKE VALVE MECHANICAL ACTUATOR CAUSE IT TO MOVE FREELY?

DECISION

- NO - Go to Step (4).
YES - Go to Step (8) to verify problem is solved.

SPRING BRAKES DO NOT RELEASE (VEHICLE BRAKES GRAB OR DRAG) - Continued**STEP**

4. IS AIR PRESSURE AT PARKING BRAKE SUPPLY LINE?
 - a. Verify engine is running.

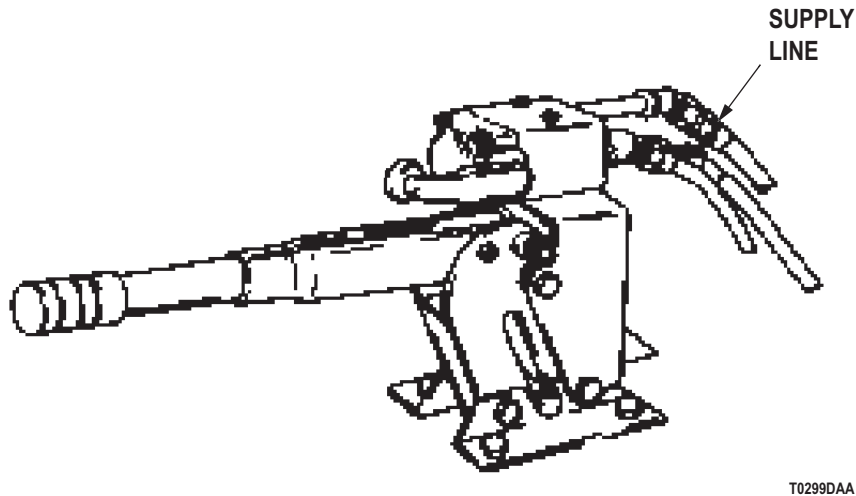

Figure 4. Parking Brake Valve.

WARNING

Loosen supply line at valve very slowly. Stop procedure and tighten fitting of supply line the moment air begins to escape. Failure to comply may result in injury or death to personnel.

- b. Slowly loosen valve supply line until any air escapes, then immediately tighten the line. Refer to point to point schematics.

CONDITION/INDICATION

IS AIR PRESSURE AT PARKING BRAKE SUPPLY LINE?

DECISION

- NO - Go to Step (5).
YES - Go to Step (6).

SPRING BRAKES DO NOT RELEASE (VEHICLE BRAKES GRAB OR DRAG) - Continued**STEP**

5. IS AIR ESCAPING FROM QUICK RELEASE VALVE?
 - a. Verify engine is running.

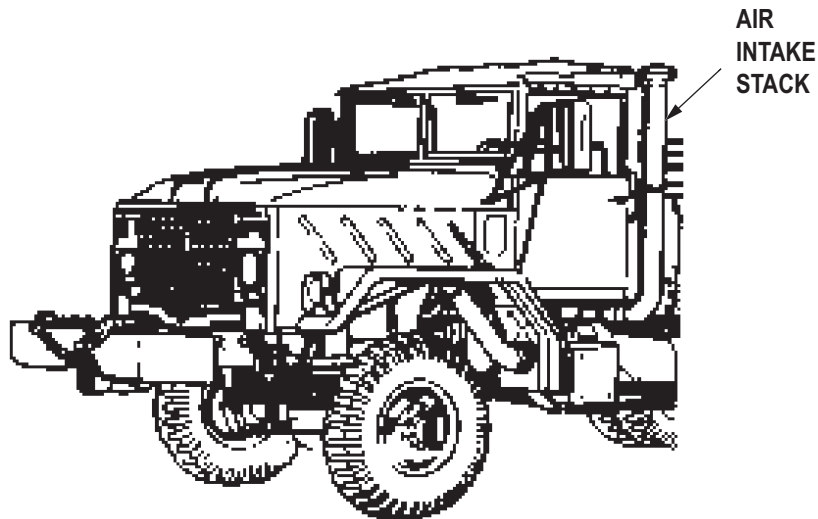

T0300DAA

Figure 5. Air Intake Stack.

- b. Release parking brake.
 - c. Listen at air intake stack for the sound of air escaping. Refer to point to point schematics.

CONDITION/INDICATION

IS AIR ESCAPING FROM QUICK RELEASE VALVE?

DECISION

NO - Go to Step (7).

YES - Replace defective quick release valve (Volume 3, WP 0477). Go to Step (8) to verify problem is solved.

SPRING BRAKES DO NOT RELEASE (VEHICLE BRAKES GRAB OR DRAG) - Continued**STEP**

6. IS AIR PRESSURE AT PARKING BRAKE DELIVERY LINE?
 - a. Verify engine is running.

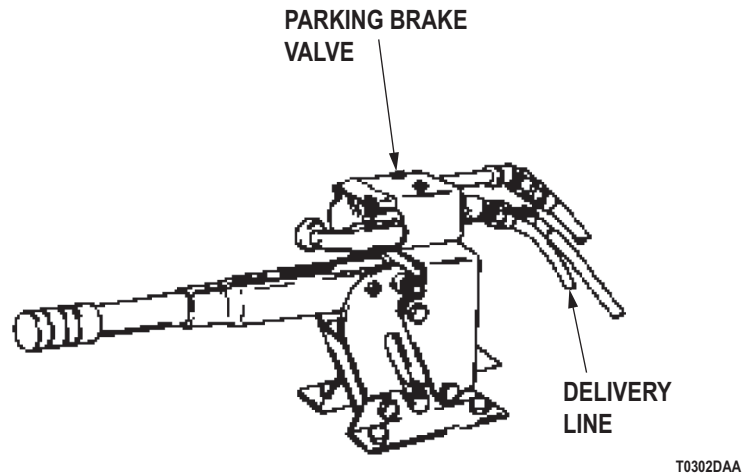

Figure 6. Parking Brake Valve.

WARNING

Loosen supply line at valve very slowly. Stop procedure and tighten fitting of supply line the moment air begins to escape. Failure to comply may result in injury or death to personnel.

- b. Release parking brake.
- c. Slowly loosen valve supply line until any air escapes, then immediately tighten the line. Refer to point to point schematics.

CONDITION/INDICATION

IS AIR PRESSURE AT PARKING BRAKE DELIVERY LINE?

DECISION

NO - Replace parking brake valve (Volume 3, WP 0431). Go to Step (8) to verify problem is solved.

YES - Notify supervisor that brake diaphragms are defective. Action is not possible at this level of maintenance.

SPRING BRAKES DO NOT RELEASE (VEHICLE BRAKES GRAB OR DRAG) - Continued

STEP

7. IS THE AIR LINE BETWEEN THE QUICK-RELEASE AND DOUBLE-CHECK VALVES CLOGGED?

Inspect for a clogged line between the quick-release and double-check valves. Refer to point to point schematics.

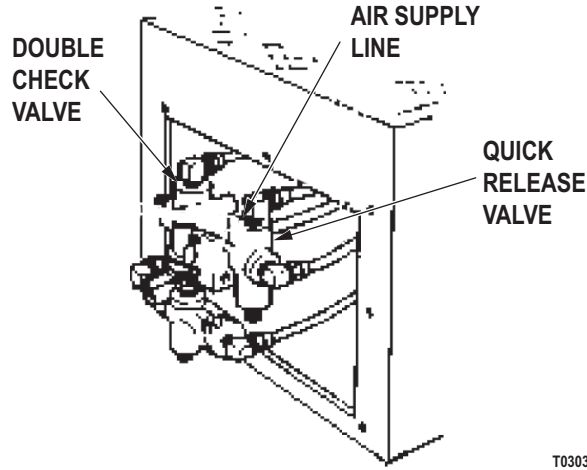

T0303DAA

Figure 7. Parking Brake Quick Release Valve Assembly.

CONDITION/INDICATION

IS THE AIR LINE BETWEEN THE QUICK-RELEASE AND DOUBLE-CHECK VALVES CLOGGED?

DECISION

YES - Clear or replace line (Volume 5, WP 0805). Go to Step (8) to verify problem is solved.

NO - Replace defective double-check valve (Volume 3, WP 0477). Go to Step (8) to verify problem is solved.

STEP

8. IS YOUR ORIGINAL BRAKE PROBLEM STILL PRESENT?

- a. Ensure vehicle is returned to normal operating condition.
- b. Check to see if your original brake problem still exists.

CONDITION/INDICATION

IS YOUR ORIGINAL BRAKE PROBLEM STILL PRESENT?

DECISION

YES - Notify supervisor.

NO - Problem fixed.

END OF WORK PACKAGE

FIELD MAINTENANCE
SPRING BRAKES DO NOT SET (GAUGES AT NORMAL OPERATING PRESSURES, AIR EXHAUSTING NOT HEARD WHEN PARKING BRAKE APPLIED)

INITIAL SETUP:**Tools and Special Tools**

Tool Kit, General Mechanic's: Automotive
(Volume 5, WP 0826, Table 1, Item 56)
Test Set, Electronic Systems
(Volume 5, WP 0826, Table 1, Item 51)

References (cont.)

Volume 3, WP 0431
Volume 3, WP 0477
Volume 5, WP 0805

Personnel Required

(2)

Equipment Condition

Vehicle parked and engine shut down.
(TM 9-2320-272-10)

References

Point to Point Schematics

TROUBLESHOOTING PROCEDURE**SPRING BRAKES DO NOT SET (GAUGES AT NORMAL OPERATING PRESSURES, AIR EXHAUSTING NOT HEARD WHEN PARKING BRAKE APPLIED)****NOTE**

Conduct these malfunction tests if spring brakes do not set. This procedure will check for spring brake release control out, parking brake not fully applied, quick release valve air lines crimped, faulty parking brake valve, and faulty quick release valve.

SPRING BRAKES DO NOT SET (GAUGES AT NORMAL OPERATING PRESSURES, AIR EXHAUSTING NOT HEARD WHEN PARKING BRAKE APPLIED) - Continued**STEP****1. IS THE SPRING BRAKE RELEASE CONTROL OUT?**

Verify that spring brake release control is not out.

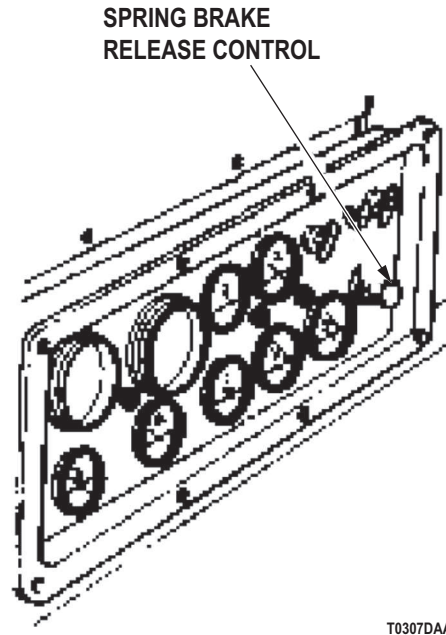

Figure 1. Spring Brake Control.

CONDITION/INDICATION

IS THE SPRING BRAKE RELEASE CONTROL OUT?

DECISION

YES - Push spring control in. Go to Step (5) to verify problem is solved.

NO - Go to Step (2).

SPRING BRAKES DO NOT SET (GAUGES AT NORMAL OPERATING PRESSURES, AIR EXHAUSTING NOT HEARD WHEN PARKING BRAKE APPLIED) - Continued**STEP****2. IS THE PARKING BRAKE FULLY APPLIED?**

Verify that the parking brake is fully applied.

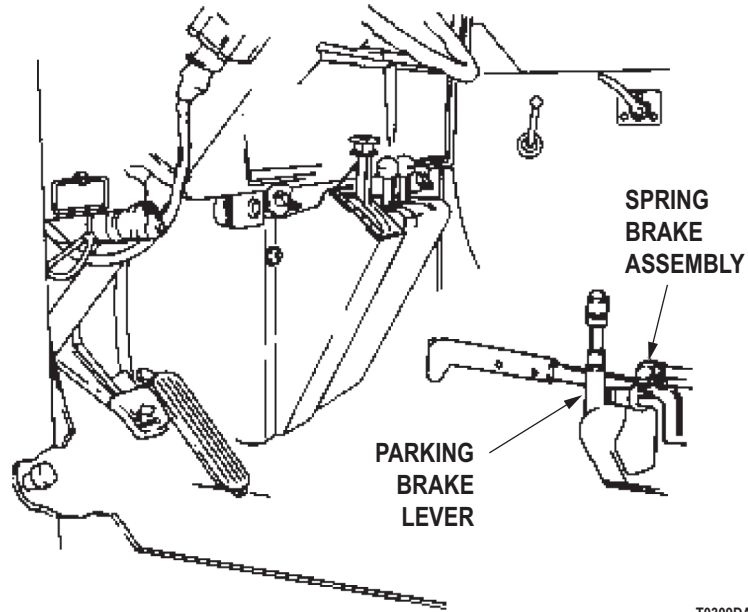

T0309DAA

Figure 2. Spring Brake Assembly.

CONDITION/INDICATION

IS THE PARKING BRAKE FULLY APPLIED?

DECISION

NO - Fully apply parking brakes. Go to Step (5) to verify problem is solved.

YES - Go to Step (3).

SPRING BRAKES DO NOT SET (GAUGES AT NORMAL OPERATING PRESSURES, AIR EXHAUSTING NOT HEARD WHEN PARKING BRAKE APPLIED) - Continued

STEP

3. ARE ANY QUICK RELEASE VALVE AIR LINES CRIMPED?

Check all air lines attached to the quick release valve. Refer to point to point schematics.

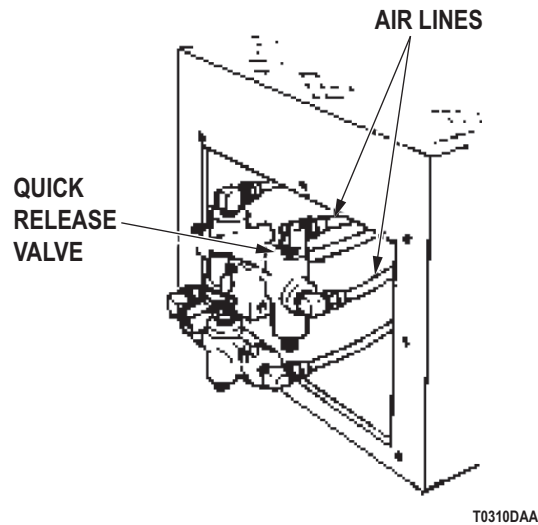

Figure 3. Quick Release Valve.

CONDITION/INDICATION

ARE ANY QUICK RELEASE VALVE AIR LINES CRIMPED?

DECISION

YES - Replace damaged air lines (Volume 5, WP 0805). Go to Step (5) to verify problem is solved.
NO - Go to Step (4).

SPRING BRAKES DO NOT SET (GAUGES AT NORMAL OPERATING PRESSURES, AIR EXHAUSTING NOT HEARD WHEN PARKING BRAKE APPLIED) - Continued

STEP

4. DOES AIR VENT THROUGH THE PARKING BRAKE VALVE VENT PORT?
 - a. Disconnect vent line from parking brake valve vent port. Refer to point to point schematics.

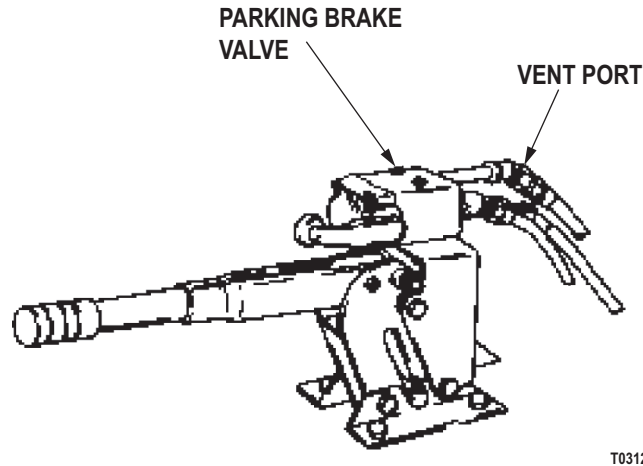

T0312DAA

Figure 4. Parking Brake Valve.

- b. Assistant starts engine and runs to build air supply to normal operating pressure.
- c. Apply spring brake.
- d. Feel for air venting through parking brake valve vent port.

CONDITION/INDICATION

DOES AIR VENT THROUGH THE PARKING BRAKE VALVE VENT PORT?

DECISION

NO - Replace quick release valve (Volume 3, WP 0477). Go to Step (5) to verify problem is solved.
 YES - Replace parking brake valve (Volume 3, WP 0431). Go to Step (5) to verify problem is solved.

SPRING BRAKES DO NOT SET (GAUGES AT NORMAL OPERATING PRESSURES, AIR EXHAUSTING NOT HEARD WHEN PARKING BRAKE APPLIED) - Continued

STEP

5. IS YOUR ORIGINAL BRAKE PROBLEM STILL PRESENT?
 - a. Ensure vehicle is returned to normal operating condition.
 - b. Check to see if your original brake problem still exists.

CONDITION/INDICATION

IS YOUR ORIGINAL BRAKE PROBLEM STILL PRESENT?

DECISION

YES - Notify supervisor.
NO - Problem fixed.

END OF WORK PACKAGE

FIELD MAINTENANCE
ALL AIR-OPERATED ACCESSORIES DO NOT OPERATE (HORN, WINDSHIELD WIPERS, WINDSHIELD WASHERS, TRANSFER CASE CONTROLS), GAUGES AT NORMAL OPERATING PRESSURE

INITIAL SETUP:**Tools and Special Tools**

Tool Kit, General Mechanic's: Automotive
(Volume 5, WP 0826, Table 1, Item 56)
Test Set, Electronic Systems
(Volume 5, WP 0826, Table 1, Item 51)

Personnel Required

(2)

References

Point to Point Schematics

References (cont.)

Volume 3, WP 0442
Volume 5, WP 0805

Equipment Condition

Vehicle parked and engine shut down.
(TM 9-2320-272-10)

TROUBLESHOOTING PROCEDURE

ALL AIR-OPERATED ACCESSORIES DO NOT OPERATE (HORN, WINDSHIELD WIPERS, WINDSHIELD WASHERS, TRANSFER CASE CONTROLS), GAUGES AT NORMAL OPERATING PRESSURE

NOTE

Conduct these malfunction tests if all air operated accessories do not work. This procedure will check for defective air lines between the governor and accessories, and the pressure protection valve.

ALL AIR-OPERATED ACCESSORIES DO NOT OPERATE (HORN, WINDSHIELD WIPERS, WINDSHIELD WASHERS, TRANSFER CASE CONTROLS), GAUGES AT NORMAL OPERATING PRESSURE - Continued

STEP

1. DO THE INSTRUMENT PANEL GAUGES INDICATE NORMAL AIR PRESSURE?
 - a. Start engine.

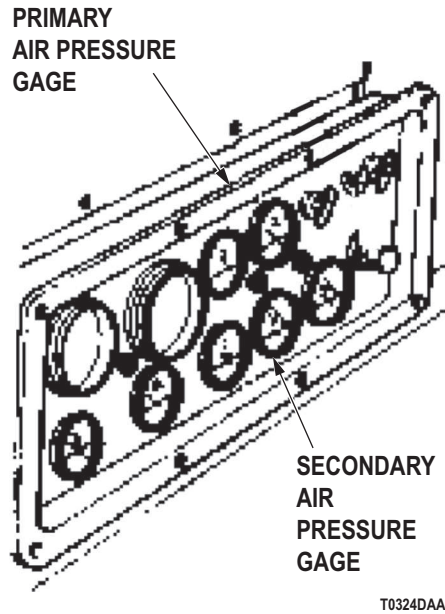

Figure 1. Air Pressure Gauges.

- b. Monitor air pressure gauges on instrument panel.
 - c. Pressure gauge should read 90 to 130 psi.

CONDITION/INDICATION

DO THE INSTRUMENT PANEL GAUGES INDICATE NORMAL AIR PRESSURE?

DECISION

- YES - Replace damaged air lines (Volume 5, WP 0805). Go to Step (2) to verify problem is solved.
NO - Replace pressure protection valve (Volume 3, WP 0442). Go to Step (2) to verify problem is solved.

ALL AIR-OPERATED ACCESSORIES DO NOT OPERATE (HORN, WINDSHIELD WIPERS, WINDSHIELD WASHERS, TRANSFER CASE CONTROLS), GAUGES AT NORMAL OPERATING PRESSURE - Continued

STEP

2. IS YOUR ORIGINAL AIR PRESSURE PROBLEM STILL PRESENT?
 - a. Ensure vehicle is returned to normal operating condition.
 - b. Check to see if your original problem still exists.

CONDITION/INDICATION

IS YOUR ORIGINAL AIR PRESSURE PROBLEM STILL PRESENT?

DECISION

YES - Notify supervisor.
NO - Problem fixed.

END OF WORK PACKAGE

FIELD MAINTENANCE
COOLING FAN DOES NOT OPERATE, ENGINE TEMPERATURE ABOVE 195°F (91°C) AS INDICATED BY TEMPERATURE GAUGE

INITIAL SETUP:**Tools and Special Tools**

Tool Kit, General Mechanic's: Automotive
(Volume 5, WP 0826, Table 1, Item 56)
Test Set, Electronic Systems
(Volume 5, WP 0826, Table 1, Item 51)

References (cont.)

WP 0106
WP 0131
Volume 3, WP 0447
Volume 3, WP 0448

Personnel Required

(2)

Equipment Condition

Vehicle parked and engine shut down.
(TM 9-2320-272-10)

References

Point to Point Schematics

TROUBLESHOOTING PROCEDURE**COOLING FAN DOES NOT OPERATE, ENGINE TEMPERATURE ABOVE 195°F (91°C) AS INDICATED BY TEMPERATURE GAUGE****NOTE**

Conduct these malfunction tests if the cooling fan does not operate and the engine temperature is above 195 °F (91°C). This procedure will check for air availability, faulty temperature gauge, and faulty fan drive clutch actuator.

COOLING FAN DOES NOT OPERATE, ENGINE TEMPERATURE ABOVE 195°F (91°C) AS INDICATED BY TEMPERATURE GAUGE - Continued**STEP**

1. IS AIR AVAILABLE TO RUN THE COOLING FAN?
 - a. Start engine.
 - b. Monitor secondary air pressure gauge on instrument panel. Refer to point to point schematics.

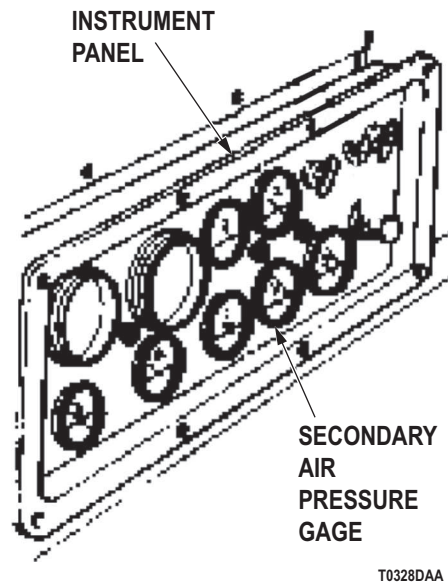

Figure 1. Secondary Air Pressure Gauge.

CONDITION/INDICATION

IS AIR AVAILABLE TO RUN THE COOLING FAN?

DECISION

YES - Go to Step (2).

NO - Perform Secondary Pressure Gauge Reads No Pressure, Low Pressure, Or Builds Too Slowly troubleshooting (WP 0131).

STEP

2. IS FAN DRIVE CLUTCH ACTUATOR FAULTY?
 - a. Shut off and allow engine to cool. Refer to point to point schematics.

COOLING FAN DOES NOT OPERATE, ENGINE TEMPERATURE ABOVE 195°F (91°C) AS INDICATED BY TEMPERATURE GAUGE - Continued

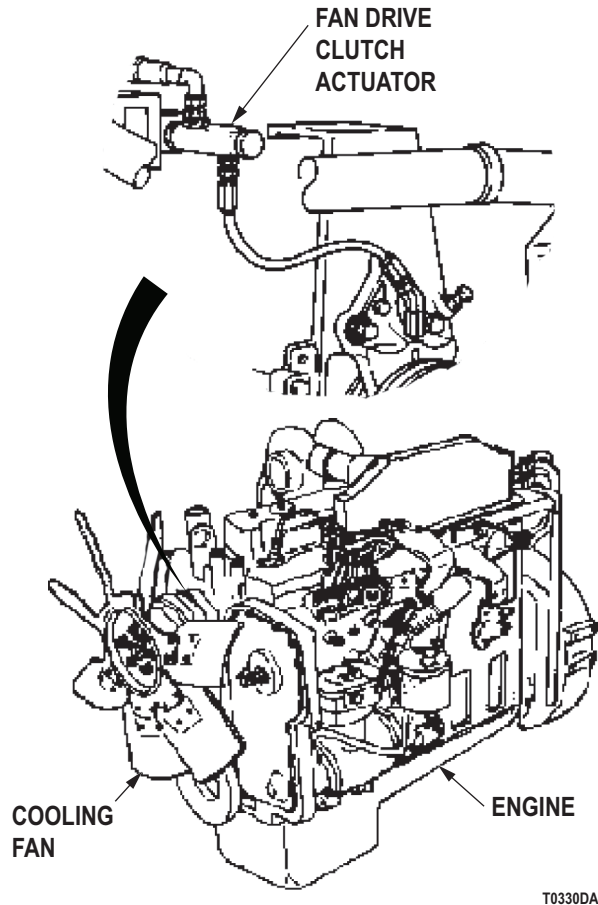

T0330DAA

Figure 2. Fan Clutch Actuator.

- b. Replace fan drive clutch actuator with a known good actuator M939/A1 (Volume 3, WP 0447), M939A2 (Volume 3, WP 0448).
- c. Start engine and bring to normal operating temperature.

NOTE

If cooling fan operates, fan drive clutch actuator was faulty.

- d. Check if cooling fan operates.
- e. Shut off and allow engine to cool.
- f. If cooling fan does not operate, replace fan drive clutch actuator with original actuator.

CONDITION/INDICATION

IS FAN DRIVE CLUTCH ACTUATOR FAULTY?

DECISION

YES - Go to Step (3) to verify problem is solved.

NO - Perform Temperature Gauge Inoperative (Coolant) troubleshooting (WP 0106).

COOLING FAN DOES NOT OPERATE, ENGINE TEMPERATURE ABOVE 195°F (91°C) AS INDICATED BY TEMPERATURE GAUGE - Continued**STEP**

3. IS YOUR ORIGINAL PROBLEM STILL PRESENT?
 - a. Ensure vehicle is returned to normal operating condition.
 - b. Check to see if your original problem still exists.

CONDITION/INDICATION

IS YOUR ORIGINAL PROBLEM STILL PRESENT?

DECISION

YES - Notify supervisor.
NO - Problem fixed.

END OF WORK PACKAGE

FIELD MAINTENANCE
COOLING FAN DOES NOT STOP RUNNING, ENGINE TEMPERATURE BELOW NORMAL OPERATING RANGE (OVERRIDE BOLT NOT INSTALLED)

INITIAL SETUP:**Tools and Special Tools**

Tool Kit, General Mechanic's: Automotive
(Volume 5, WP 0826, Table 1, Item 56)
Test Set, Electronic Systems
(Volume 5, WP 0826, Table 1, Item 51)

Personnel Required

(2)

References

Point to Point Schematics

References (cont.)

Volume 3, WP 0447
Volume 3, WP 0448

Equipment Condition

Vehicle parked and engine shut down.
(TM 9-2320-272-10)

TROUBLESHOOTING PROCEDURE**COOLING FAN DOES NOT STOP RUNNING, ENGINE TEMPERATURE BELOW NORMAL OPERATING RANGE (OVERRIDE BOLT NOT INSTALLED)****NOTE**

Conduct these malfunction tests if the cooling fan does not stop running and the engine temperature is below the normal operating range. This procedure will check for a faulty fan drive clutch actuator.

COOLING FAN DOES NOT STOP RUNNING, ENGINE TEMPERATURE BELOW NORMAL OPERATING RANGE (OVERRIDE BOLT NOT INSTALLED) - Continued

STEP

1. IS THE FAN DRIVE CLUTCH ACTUATOR FAULTY?
 - a. Allow engine to cool. Refer to point to point schematics.

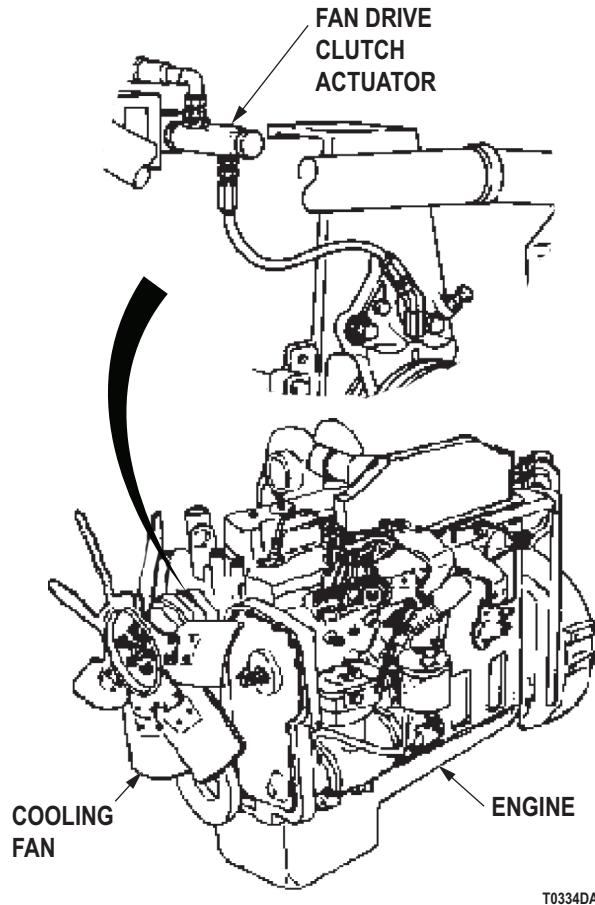

Figure 1. Fan Clutch Actuator.

- b. Replace fan drive clutch actuator M939/A1 (Volume 3, WP 0447), M939A2 (Volume 3, WP 0448).
- c. Start engine and bring to normal operating temperature.
- d. If cooling fan operates only when needed, fan drive clutch actuator was faulty.

CONDITION/INDICATION

IS THE FAN DRIVE CLUTCH ACTUATOR FAULTY?

DECISION

- YES - Go to Step (2) to verify problem is solved.
 NO - Notify supervisor. It is possible another troubleshooting work package applies.

COOLING FAN DOES NOT STOP RUNNING, ENGINE TEMPERATURE BELOW NORMAL OPERATING RANGE (OVERRIDE BOLT NOT INSTALLED) - Continued**STEP**

2. IS YOUR ORIGINAL PROBLEM STILL PRESENT?
 - a. Ensure vehicle is returned to normal operating condition.
 - b. Check to see if your original problem still exists.

CONDITION/INDICATION

IS YOUR ORIGINAL PROBLEM STILL PRESENT?

DECISION

YES - Notify supervisor.
NO - Problem fixed.

END OF WORK PACKAGE

FIELD MAINTENANCE
FRONT WHEEL DRIVE DOES NOT ENGAGE (FRONT WHEEL DRIVE LOCK-IN SWITCH ENGAGED AND
TRANSFER CASE SHIFT LEVER IN HIGH POSITION)

INITIAL SETUP:**Tools and Special Tools**

Tool Kit, General Mechanic's: Automotive
(Volume 5, WP 0826, Table 1, Item 56)
Gauge, Pressure
(Volume 5, WP 0826, Table 1, Item 19)
Test Set, Electronic Systems
(Volume 5, WP 0826, Table 1, Item 51)

References (cont.)

WP 0131
Volume 3, WP 0389
Volume 5, WP 0805

Equipment Condition

Vehicle parked and engine shut down.
(TM 9-2320-272-10)

Personnel Required

(2)

References

Point to Point Schematics

TROUBLESHOOTING PROCEDURE**FRONT WHEEL DRIVE DOES NOT ENGAGE (FRONT WHEEL DRIVE LOCK-IN SWITCH ENGAGED AND**
TRANSFER CASE SHIFT LEVER IN HIGH POSITION)**NOTE**

Conduct these malfunction tests if front wheel drive does not engage. This procedure will check for leaking air lines from the actuator valve to transfer case and the supply line from the actuator valve to transfer case. It also checks for faulty actuator valve, front wheel drive lock-in switch, and air line from actuator valve to front wheel drive lock-in switch. Finally, it checks for transfer case not engaging front wheel drive, and air not being delivered to the actuator valve.

FRONT WHEEL DRIVE DOES NOT ENGAGE (FRONT WHEEL DRIVE LOCK-IN SWITCH ENGAGED AND TRANSFER CASE SHIFT LEVER IN HIGH POSITION) - Continued**STEP**

1. DOES FRONT WHEEL DRIVE FUNCTION WITH TRANSFER CASE SHIFT LEVER IN LOW POSITION?
 - a. Start engine.

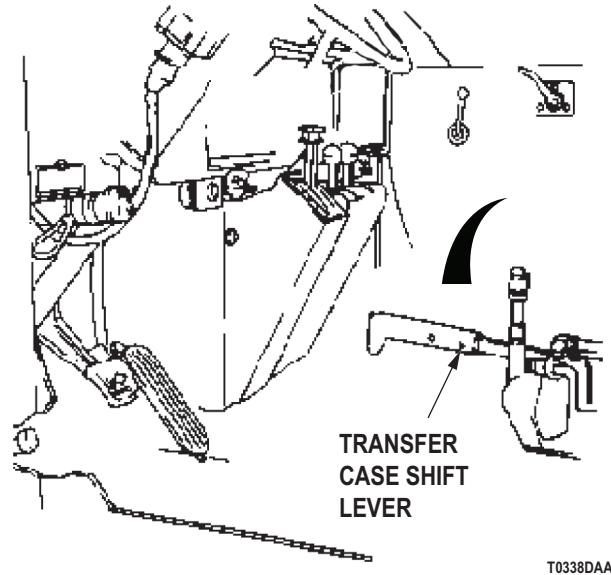

Figure 1. Transfer Case Shift Lever.

- b. Place transfer case shift lever in low position.
 - c. Check front wheel drive operation.

CONDITION/INDICATION

DOES FRONT WHEEL DRIVE FUNCTION WITH TRANSFER CASE SHIFT LEVER IN LOW POSITION?

DECISION

- NO - Go to Step (2).
YES - Go to Step (6).

FRONT WHEEL DRIVE DOES NOT ENGAGE (FRONT WHEEL DRIVE LOCK-IN SWITCH ENGAGED AND TRANSFER CASE SHIFT LEVER IN HIGH POSITION) - Continued

STEP

2. DOES AIR SYSTEM LEAK WITH SHIFT LEVER IN HIGH POSITION?

- a. Place transfer case shift lever into high position. Refer to point to point schematics.

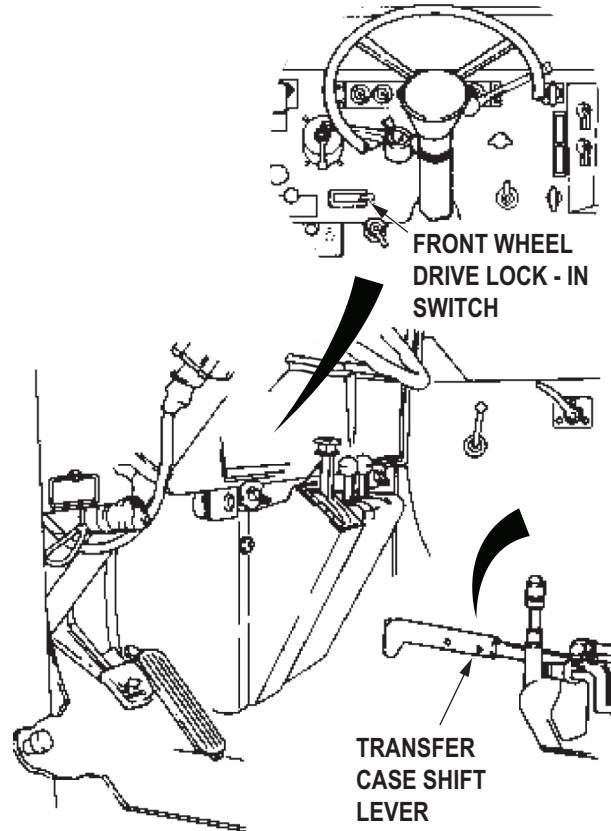

Figure 2. Transfer Case Shift Lever and Drive Lock In Switch.

- b. Engage front wheel drive lock-in switch.
 c. Start engine and allow air pressure to build to normal operating pressure.
 d. Stop engine and observe secondary air pressure gauge.
 e. If pressure gauge indicates a steady loss of pressure, system is leaking.

CONDITION/INDICATION

DOES AIR SYSTEM LEAK WITH SHIFT LEVER IN HIGH POSITION?

DECISION

YES - Perform Secondary Pressure Gauge Reads No Pressure, Low Pressure, Or Builds To Normal Operating Pressure Slowly troubleshooting (WP 0131).
 NO - Go to Step (3).

FRONT WHEEL DRIVE DOES NOT ENGAGE (FRONT WHEEL DRIVE LOCK-IN SWITCH ENGAGED AND TRANSFER CASE SHIFT LEVER IN HIGH POSITION) - Continued

STEP

3. DOES AIR SYSTEM LEAK WITH SHIFT LEVER IN LOW POSITION?

- a. Place transfer case shift lever into low position. Refer to point to point schematics.

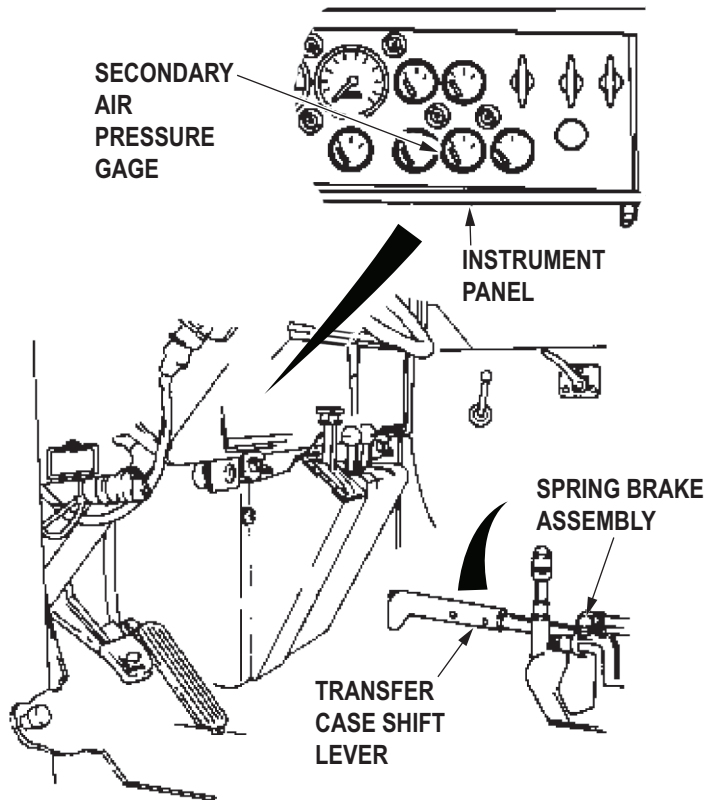

T0342DAA

Figure 3. Transfer Case Shift Lever.

- b. Observe secondary air pressure gauge.
c. If pressure gauge indicates a steady loss of pressure, system is leaking.

CONDITION/INDICATION

DOES AIR SYSTEM LEAK WITH SHIFT LEVER IN LOW POSITION?

DECISION

- YES - Go to Step (4).
NO - Go to Step (8).

FRONT WHEEL DRIVE DOES NOT ENGAGE (FRONT WHEEL DRIVE LOCK-IN SWITCH ENGAGED AND TRANSFER CASE SHIFT LEVER IN HIGH POSITION) - Continued

STEP

4. IS THERE A LEAK FROM THE AIR LINE BETWEEN THE ACTUATOR VALVE AND THE TRANSFER CASE?

Inspect the air line between the actuator valve and the transfer case for an air leak. Refer to point to point schematics.

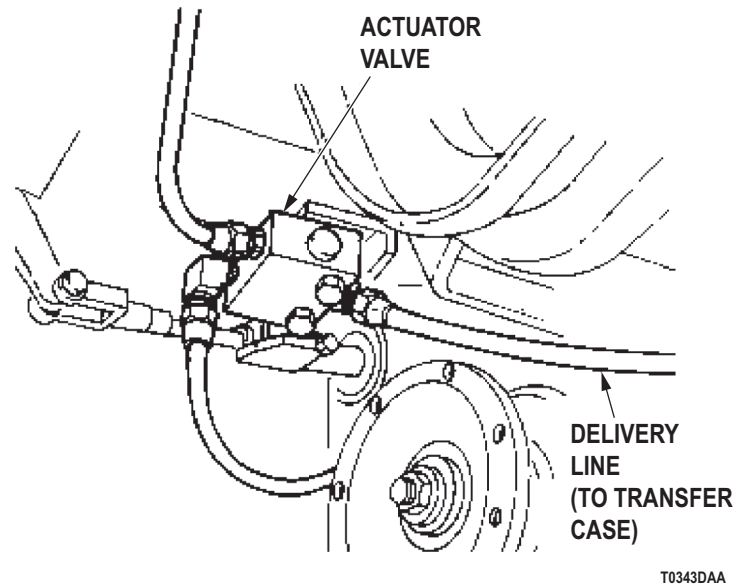

Figure 4. Air Line Between Actuator Valve and Transfer Case.

CONDITION/INDICATION

IS THERE A LEAK FROM THE AIR LINE BETWEEN THE ACTUATOR VALVE AND THE TRANSFER CASE?

DECISION

YES - Replace damaged air lines (Volume 5, WP 0805). Go to Step (10) to verify problem is solved.
NO - Go to Step (5).

FRONT WHEEL DRIVE DOES NOT ENGAGE (FRONT WHEEL DRIVE LOCK-IN SWITCH ENGAGED AND TRANSFER CASE SHIFT LEVER IN HIGH POSITION) - Continued**STEP****5. IS THERE AN AIR LEAK FROM THE SUPPLY LINE AT THE ACTUATOR VALVE?**

Inspect the supply line attached to the actuator valve for an air leak. Refer to point to point schematics.

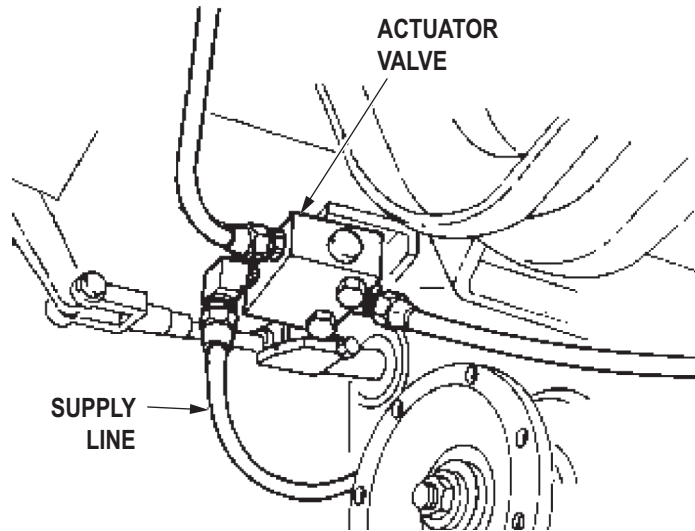

T0345DAA

Figure 5. Air Supply Line to Actuator Valve.

CONDITION/INDICATION

IS THERE AN AIR LEAK FROM THE SUPPLY LINE AT THE ACTUATOR VALVE?

DECISION

YES - Replace damaged air lines (Volume 5, WP 0805). Go to Step (10) to verify problem is solved.
NO - Notify supervisor. Action may not be possible at this level of maintenance.

FRONT WHEEL DRIVE DOES NOT ENGAGE (FRONT WHEEL DRIVE LOCK-IN SWITCH ENGAGED AND TRANSFER CASE SHIFT LEVER IN HIGH POSITION) - Continued

STEP

6. IS THERE AIR PRESSURE IN THE AIR LINE BETWEEN THE ACTUATOR VALVE AND THE FRONT WHEEL DRIVE LOCK-IN SWITCH?
 - a. Disconnect air line from actuator valve. Refer to point to point schematics.

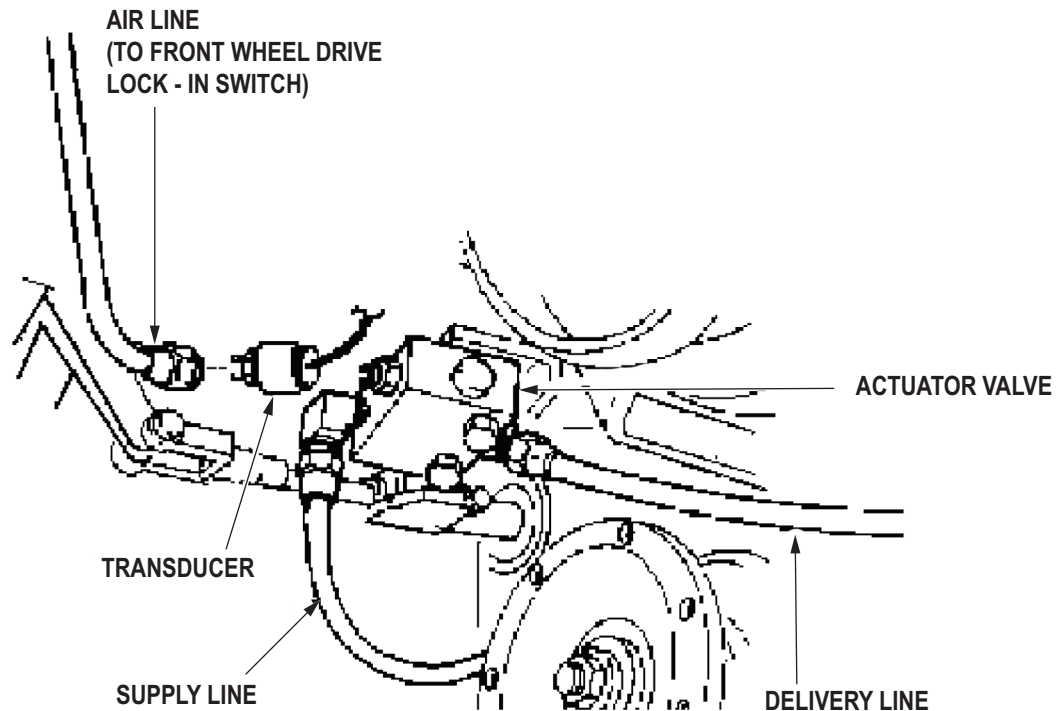

T0320DAA

Figure 6. Air Supply Line to Actuator Valve.

- b. Connect pressure gauge to disconnected air line.
- c. Start engine and run at idle.
- d. Place transfer case shift lever into high position.
- e. Engage front wheel drive lock-in switch.
- f. Monitor air pressure on pressure gauge.
- g. After 5 minutes air pressure should read 90 to 130 psi.

CONDITION/INDICATION

IS THERE AIR PRESSURE IN THE AIR LINE BETWEEN THE ACTUATOR VALVE AND THE FRONT WHEEL DRIVE LOCK-IN SWITCH?

DECISION

YES - Notify supervisor. Action may not be possible at this level of maintenance.
 NO - Go to Step (7).

FRONT WHEEL DRIVE DOES NOT ENGAGE (FRONT WHEEL DRIVE LOCK-IN SWITCH ENGAGED AND TRANSFER CASE SHIFT LEVER IN HIGH POSITION) - Continued

STEP

7. IS THERE AIR PRESSURE IN THE AIR LINE CONNECTED TO THE FRONT WHEEL DRIVE LOCK-IN SWITCH?
 - a. Stop engine.
 - b. Disconnect pressure gauge from vehicle and return air line to original condition.
 - c. Disconnect air line from front wheel drive lock-in switch. Refer to point to point schematics.

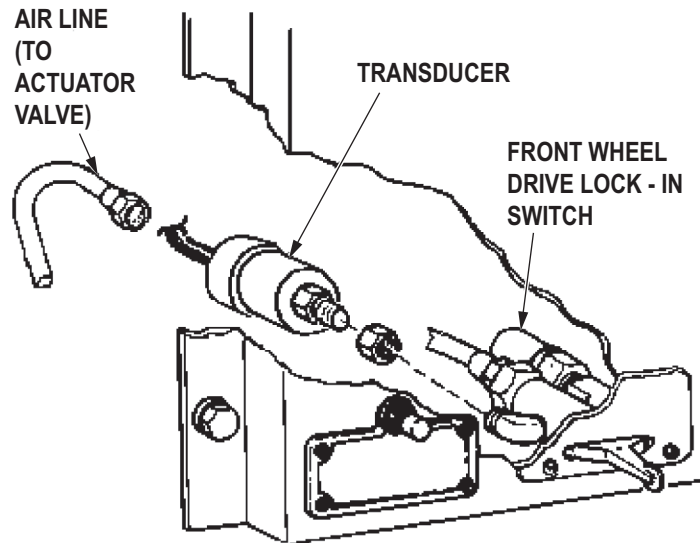

T0348DAA

Figure 7. Front Wheel Drive Lock-in Switch.

- d. Connect pressure gauge to front wheel drive lock-in switch.
- e. Start engine and run at idle.
- f. Place transfer case shift lever into high position.
- g. Engage front wheel drive lock-in switch.
- h. Monitor air pressure on pressure gauge.
- i. After 5 minutes air pressure should read 90 to 130 psi.

CONDITION/INDICATION

IS THERE AIR PRESSURE IN THE AIR LINE CONNECTED TO THE FRONT WHEEL DRIVE LOCK-IN SWITCH?

DECISION

YES - Replace defective air line at the front wheel drive lock-in valve (Volume 5, WP 0805). Go to Step (10) to verify problem is solved.

NO - Replace defective front wheel drive lock-in switch (Volume 3, WP 0389). Go to Step (10) to verify problem is solved.

FRONT WHEEL DRIVE DOES NOT ENGAGE (FRONT WHEEL DRIVE LOCK-IN SWITCH ENGAGED AND TRANSFER CASE SHIFT LEVER IN HIGH POSITION) - Continued

STEP

8. IS THERE AIR PRESSURE IN THE AIR LINE BETWEEN THE ACTUATOR VALVE AND THE TRANSFER CASE?
- Verify engine is stopped.
 - Disconnect delivery air line from transfer case. Refer to point to point schematics.

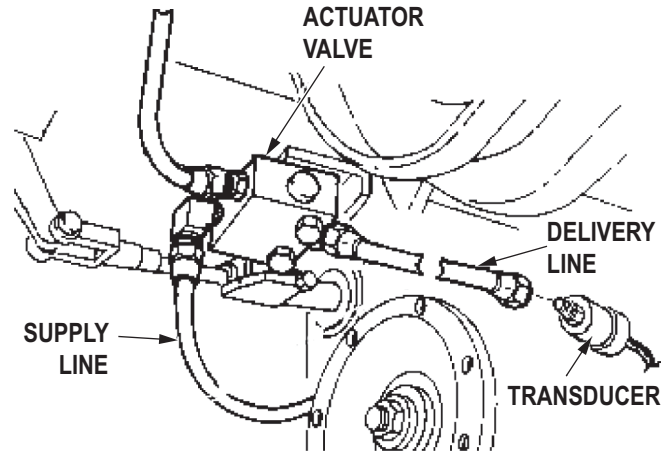

T0351DAA

Figure 8. Actuator Valve.

- Connect pressure gauge to disconnected air line.
- Start engine and run at idle.
- Place transfer case shift lever into low position.
- Monitor air pressure on pressure gauge.
- After 5 minutes air pressure should read 90 to 130 psi.

CONDITION/INDICATION

IS THERE AIR PRESSURE IN THE AIR LINE BETWEEN THE ACTUATOR VALVE AND THE TRANSFER CASE?

DECISION

YES - Notify supervision that transfer case is faulty. Action may not be possible at this level of maintenance.
NO - Go to Step (9).

FRONT WHEEL DRIVE DOES NOT ENGAGE (FRONT WHEEL DRIVE LOCK-IN SWITCH ENGAGED AND TRANSFER CASE SHIFT LEVER IN HIGH POSITION) - Continued

STEP

9. IS THERE AIR PRESSURE IN THE IR LINE AT THE ACTUATOR VALVE DELIVERY PORT?
- Stop engine.
 - Disconnect pressure gauge from vehicle and return air line to original condition.
 - Disconnect delivery air line from actuator valve delivery port. Refer to point to point schematics.

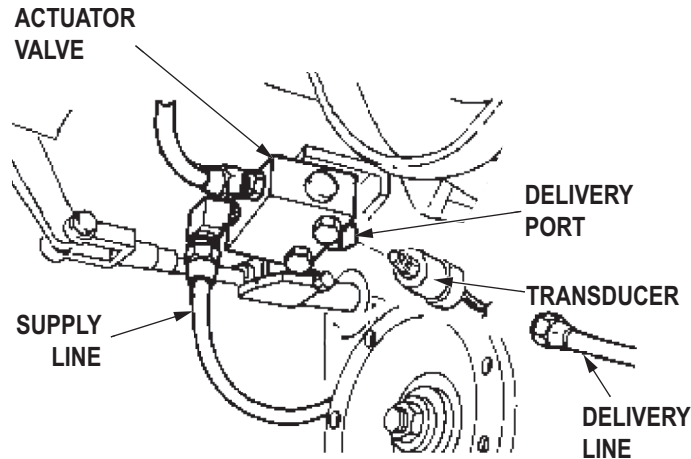

T0353DAA

Figure 9. Actuator Valve.

- Connect pressure gauge to actuator valve delivery port.
- Start engine and run at idle.
- Place transfer case shift lever into low position.
- Monitor air pressure on pressure gauge.
- After 5 minutes air pressure should read 90 to 130 psi.

CONDITION/INDICATION

IS THERE AIR PRESSURE IN THE AIR LINE AT THE ACTUATOR VALVE DELIVERY PORT?

DECISION

YES - Replace damaged air lines (Volume 5, WP 0805). Go to Step (10) to verify problem is solved.
 NO - Notify supervisor. Action may not be possible at this level of maintenance.

FRONT WHEEL DRIVE DOES NOT ENGAGE (FRONT WHEEL DRIVE LOCK-IN SWITCH ENGAGED AND TRANSFER CASE SHIFT LEVER IN HIGH POSITION) - Continued**STEP**

10. IS YOUR ORIGINAL PROBLEM STILL PRESENT?
 - a. Ensure vehicle is returned to normal operating condition.
 - b. Check to see if your original problem still exists.

CONDITION/INDICATION

IS YOUR ORIGINAL PROBLEM STILL PRESENT?

DECISION

YES - Notify supervisor.
NO - Problem fixed.

END OF WORK PACKAGE

FIELD MAINTENANCE
HORN DOES NOT WORK (GAUGES AT NORMAL OPERATING PRESSURE, WARNING BUZZER NOT SOUNDING)

INITIAL SETUP:**Tools and Special Tools**

Tool Kit, General Mechanic's: Automotive
(Volume 5, WP 0826, Table 1, Item 56)
Test Set, Electronic Systems
(Volume 5, WP 0826, Table 1, Item 51)

Personnel Required

(2)

References

Point to Point Schematics

References (cont.)

WP 0109
Volume 5, WP 0805

Equipment Condition

Vehicle parked and engine shut down.
(TM 9-2320-272-10)

TROUBLESHOOTING PROCEDURE**HORN DOES NOT WORK (GAUGES AT NORMAL OPERATING PRESSURE, WARNING BUZZER NOT SOUNDING)****NOTE**

Conduct these malfunction tests if the horn does not work. This procedure will check for a defective air supply line.

HORN DOES NOT WORK (GAUGES AT NORMAL OPERATING PRESSURE, WARNING BUZZER NOT SOUNDING) - Continued

STEP

1. IS THERE AIR AT THE AIR ELECTRIC VALVE?
 - a. Start engine and allow air pressure to build to normal operating pressure.
 - b. Stop engine.

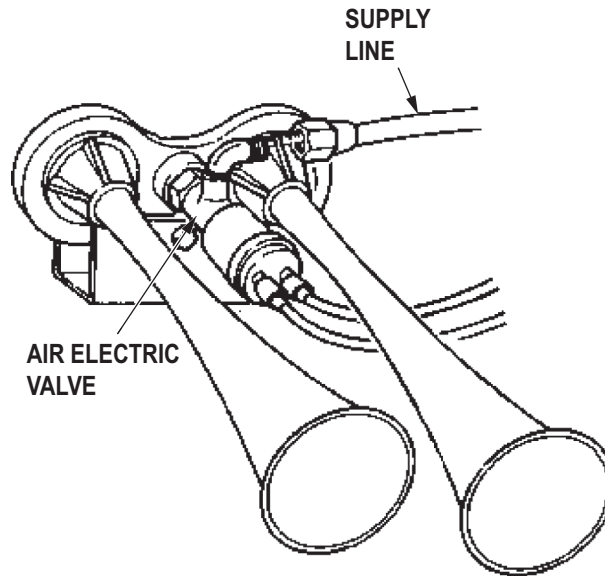

T0357DAA

Figure 1. Air Horn.

WARNING

Loosen supply line at valve very slowly. Stop procedure and tighten fitting of supply line the moment air begins to escape. Failure to comply may result in injury or death to personnel.

- c. Loosen air supply line very slowly. Refer to point to point schematics.

CONDITION/INDICATION

IS THERE AIR AT THE AIR ELECTRIC VALVE?

DECISION

NO - Replace damaged supply air line (Volume 5, WP 0805). Go to Step (2) to verify problem is solved.
 YES - Perform Horn Inoperative electrical circuit troubleshooting (WP 0109).

HORN DOES NOT WORK (GAUGES AT NORMAL OPERATING PRESSURE, WARNING BUZZER NOT SOUNDING) - Continued**STEP**

2. IS YOUR ORIGINAL PROBLEM STILL PRESENT?
 - a. Ensure vehicle is returned to normal operating condition.
 - b. Check to see if your original problem still exists.

CONDITION/INDICATION

IS YOUR ORIGINAL PROBLEM STILL PRESENT?

DECISION

YES - Notify supervisor.
NO - Problem fixed.

END OF WORK PACKAGE

CHAPTER 3

CTIS TROUBLESHOOTING PROCEDURES

FIELD MAINTENANCE CENTRAL TIRE INFLATION SYSTEM (CTIS) TROUBLESHOOTING

INTRODUCTION

1. This chapter provides information needed to diagnose and correct malfunctions of the Central Tire Inflation System (CTIS) at the field level of maintenance.
2. The troubleshooting procedures in this section cannot give all the answers or correct all vehicle malfunctions encountered. However, these procedures are a step-by-step approach to a problem that directs tests and inspections toward the source of a problem and a successful solution.
3. For most system components connected by wiring or pneumatic tubing, intermittent malfunctions are the most difficult to correct. In many instances, erratic operation can be traced to faulty electrical or pneumatic connections.
4. The wiring schematic (Volume 5, WP 0828) and point to point schematics show the interrelationship of these systems. Both should be utilized as references when performing troubleshooting procedures.
5. The compressed air schematic (Volume 5, WP 0828) and point to point schematics show the interrelationship of the compressed air and brake system. Both should be used as a reference when performing troubleshooting procedures.
6. Each malfunction symptom given for an individual component or system is followed by step(s) to determine the cause and corrective action you must take to remedy the problem.
7. Before taking any corrective action for a possible malfunction, the following rules should be followed:
 - a. Question operator to obtain any additional information that might help you to determine the cause of the problem.
 - b. Never overlook the chance the problem could be of a simple origin. The problem could require only a minor adjustment.
 - c. Use all senses to observe and locate troubles.
 - d. Use test instruments and gauges to help you determine and isolate problems.
 - e. Always isolate the system where the malfunction occurs and locate the defective component.
 - f. Use standard automotive theories and principles when troubleshooting the vehicles covered in this manual.
 - g. Operate the vehicle yourself to ensure the operator's description of the problem is correct.
8. This section cannot list all malfunctions that may occur. If a malfunction occurs that is not listed in the index, notify supervisor.
9. If malfunction corrective action does not correct malfunction, notify supervisor.

EXPLANATION OF TROUBLESHOOTING PROCEDURES

Troubleshooting procedures are defined as follows:

1. **STEP:** An action or process taken to isolate cause of fault.
2. **CONDITION/INDICATION:** States possible fault that may cause the symptom.
3. **DECISION:** Action required to move forward with next step or correct the fault.

END OF WORK PACKAGE

FIELD MAINTENANCE
CTIS TROUBLESHOOTING INDEX

CTIS TROUBLESHOOTING INDEX

Malfunction/Symptom

Troubleshooting Procedure

CENTRAL TIRE INFLATION SYSTEM

- 1. TWO PRESSURE MODES INDICATED WITH STEADY
MODE LIGHTS..... WP 0144
- 2. FOUR PRESSURE MODE LIGHTS FLASHING..... WP 0145
- 3. FIVE INDICATOR LIGHTS FLASHING..... WP 0146
- 4. SYSTEM REPEATEDLY RESUMES CYCLING 30 SECONDS
AFTER MODE LIGHT STOPS FLASHING..... WP 0147
- 5. SYSTEM FAILS TO DEFLATE, PARTIALLY DEFLATES, OR
TIRE PRESSURES ARE IMBALANCED..... WP 0148
- 6. CONTROL PANEL LIGHTS WORK, SYSTEM FAILS TO
INFLATE OR DEFLATE..... WP 0149
- 7. LOSS OF AMBER WARNING LIGHT AND/OR OVERSPEED
LIGHT..... WP 0150
- 8. SOLID OVERSPEED WARNING LIGHT..... WP 0151
- 9. SYSTEM OVER-INFLATES TIRES..... WP 0152
- 10. SLOW AIR RECOVERY OR OCCASIONAL LOW AIR
WARNING DURING BRAKING..... WP 0153

END OF WORK PACKAGE

FIELD MAINTENANCE
TWO PRESSURE MODES INDICATED WITH STEADY MODE LIGHTS

INITIAL SETUP:**Tools and Special Tools**

Tool Kit, General Mechanic's: Automotive
(Volume 5, WP 0826, Table 1, Item 56)
Goggles, Industrial
(Volume 5, WP 0826, Table 1, Item 20)
Multimeter
(Volume 5, WP 0826, Table 1, Item 34)
Soap Solution
Test Set, Electronic Systems
(Volume 5, WP 0826, Table 1, Item 51)

Personnel Required

(2)

References

Point to Point Schematics
WP 0006
WP 0128

References (cont.)

Volume 2, WP 0322
Volume 3, WP 0352
Volume 3, WP 0481
Volume 3, WP 0482
Volume 3, WP 0487
Volume 5, WP 0805
Volume 5, WP 0806
Volume 5, WP 0809
Volume 5, WP 0810
Volume 5, WP 0811
Volume 5, WP 0812
Volume 5, WP 0813

Equipment Condition

Vehicle parked and engine shut down.
(TM 9-2320-272-10)

TROUBLESHOOTING PROCEDURE**TWO PRESSURE MODES INDICATED WITH STEADY MODE LIGHTS****NOTE**

- Conduct these malfunction tests if two pressure modes are indicated with steady mode lights. This procedure will check for a problem with air lines between pneumatic controller and wet tank, between quick release valves and pneumatic controller, and between quick release valves and wheels. It will also check for a faulty filter element, water separator, hub air seal, pneumatic controller, quick release valve, and CTIS wiring harness.
- The Electronic Control Unit (ECU) has five pressure mode settings, with each setting having a mode light. If, during programmed operation or after manually selecting a pressure mode setting, two mode lights remain on, the CTIS will discontinue operation. Two steady mode lights indicate that a particular inflate or deflate sequence has taken longer than the programmed limits allow, and has shut the system off with air pressure between the modes, indicated by lights. Use test box and follow the procedures below to diagnose the system.

TWO PRESSURE MODES INDICATED WITH STEADY MODE LIGHTS - Continued

STEP

1. WAS THE SYSTEM INFLATING WHEN IT STOPPED BETWEEN MODES?

CONDITION/INDICATION

WAS THE SYSTEM INFLATING WHEN IT STOPPED BETWEEN MODES?

DECISION

- YES - Inflating. Go to Step (2).
- NO - Deflating. Go to Step (15).

STEP

2. DO AIR LINES BETWEEN WET TANK AND PNEUMATIC CONTROLLER HAVE CRACKS OR OTHER DAMAGE?
 - a. Refer to point to point schematics.

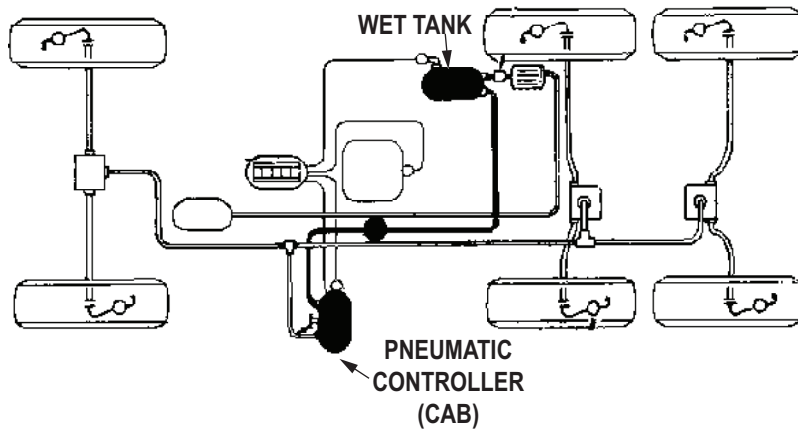

T0866DAA

Figure 1. Air Lines.

WARNING

Air system components are subject to high pressure. Always relieve pressure before loosening or removing air system components. Failure to comply may result in injury or death to personnel.

- b. Inspect air lines between wet tank and pneumatic controller for cracks and damage.

CONDITION/INDICATION

DO AIR LINES BETWEEN WET TANK AND PNEUMATIC CONTROLLER HAVE CRACKS OR OTHER DAMAGE?

DECISION

- YES - Replace damaged air lines (Volume 5, WP 0805). Go to Step (23) to verify problem is solved.
- NO - Go to Step (3).

TWO PRESSURE MODES INDICATED WITH STEADY MODE LIGHTS - Continued**STEP**

3. DO AIR LINES BETWEEN WET TANK AND PNEUMATIC CONTROLLER HAVE ANY AIR LEAKS?
 - a. Refer to point to point schematics.

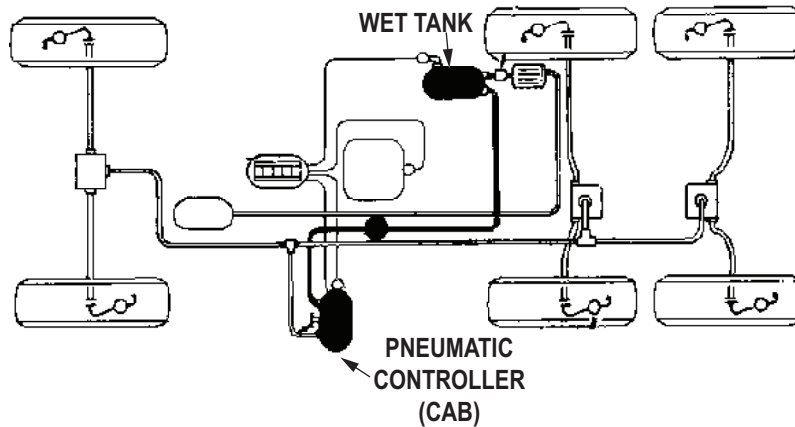

T0866DAA

Figure 2. Air Lines.

- b. Use soapy water at connections to check for air leaks.

CONDITION/INDICATION

DO AIR LINES BETWEEN WET TANK AND PNEUMATIC CONTROLLER HAVE ANY AIR LEAKS?

DECISION

YES - Tighten loose tubing connections (Volume 5, WP 0805). Go to Step (23) to verify problem is solved.
 NO - Go to Step (4).

TWO PRESSURE MODES INDICATED WITH STEADY MODE LIGHTS - Continued

STEP

4. ARE AIR LINES BETWEEN WET TANK AND PNEUMATIC CONTROLLER RESTRICTED?
 - a. Refer to point to point schematics.

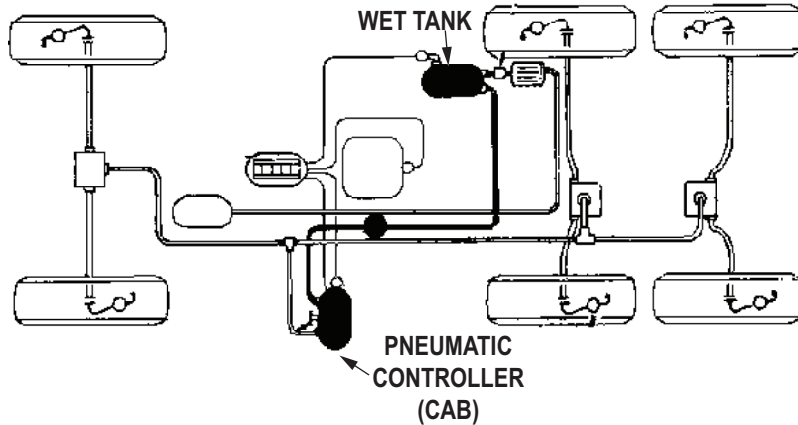

T0866DAA

Figure 3. Air Lines.

WARNING

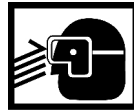

- Release all air pressure before loosening or removing air system component(s). Failure to comply may result in injury or death to personnel.
- Eyeshields must be worn when releasing compressed air. Failure to comply may result in injury or death to personnel.

- b. Disconnect air line at both ends.
- c. Check air line for restrictions.

CONDITION/INDICATION

ARE AIR LINES BETWEEN WET TANK AND PNEUMATIC CONTROLLER RESTRICTED?

DECISION

YES - Clear restriction, then reconnect air line (Volume 5, WP 0805). Go to Step (23) to verify problem is solved.
 NO - Go to Step (5).

TWO PRESSURE MODES INDICATED WITH STEADY MODE LIGHTS - Continued**STEP**

5. IS THE AIR SUPPLY FROM THE VEHICLE AIR COMPRESSOR NORMAL?
 - a. Start engine.

NOTE

If steady mode lights extinguish, air supply is normal.

- b. Repeat inflation sequence with engine running at 1000 rpm for three to five minutes.

CONDITION/INDICATION

IS THE AIR SUPPLY FROM THE VEHICLE AIR COMPRESSOR NORMAL?

DECISION

YES - Two steady mode lights are extinguished. Go to Step (6).

NO - Two steady mode lights persist. Perform Air Pressure Builds Slowly troubleshooting (WP 0128).

STEP

6. ARE THE AIR DRYER OR WATER SEPARATOR CLOGGED OR DAMAGED?

Check air dryer and water separator for clogs or damage.

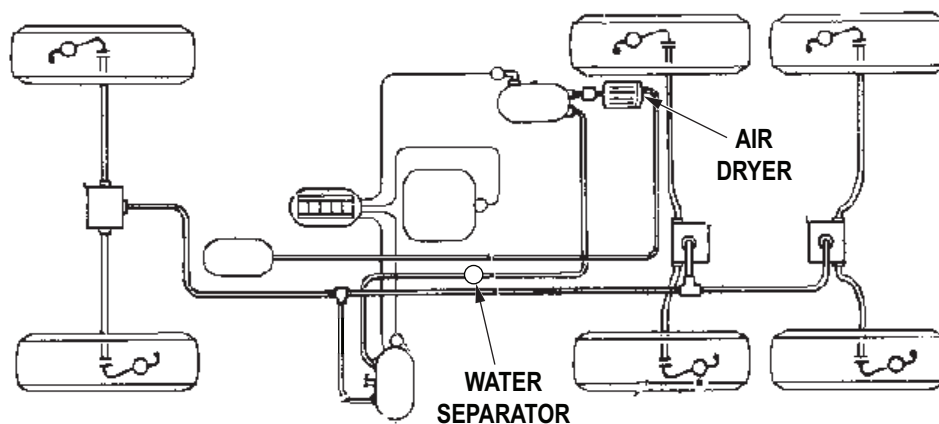

T0414DAA

Figure 4. Air Dryer And Water Separator.

CONDITION/INDICATION

ARE THE AIR DRYER OR WATER SEPARATOR CLOGGED OR DAMAGED?

DECISION

YES - If air dryer is clogged or damaged, go to Air Dryer Kit Replacement (Volume 5, WP 0806).

YES - If water separator is clogged or damaged, go to Water Separator Replacement (Volume 5, WP 0811).

NO - Go to Step (7).

TWO PRESSURE MODES INDICATED WITH STEADY MODE LIGHTS - Continued**STEP**

7. DO AIR LINES BETWEEN QUICK RELEASE VALVES AND PNEUMATIC CONTROLLER HAVE CRACKS OR OTHER DAMAGE?
- a. Refer to point to point schematics.

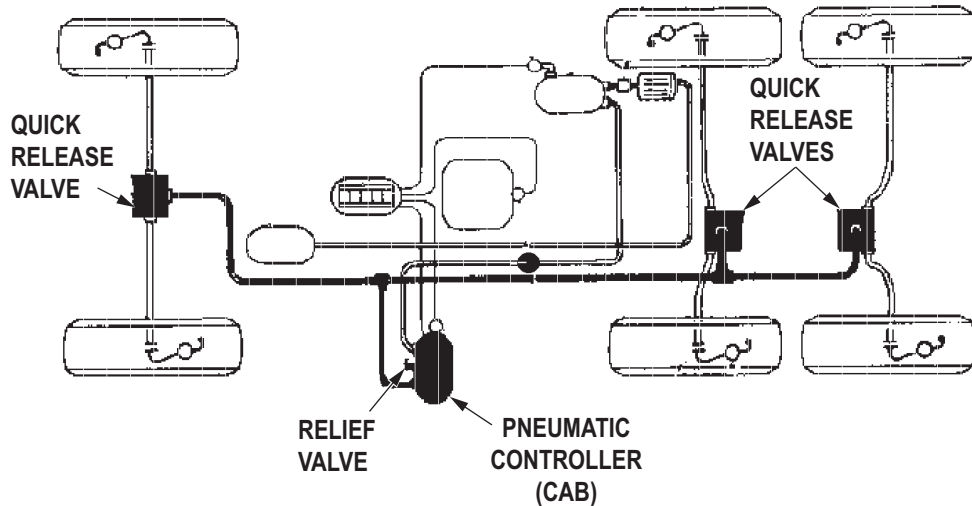

T0978DAA

Figure 5. Quick Release Valves And Pneumatic Controller.

WARNING

Air system components are subject to high pressure. Always relieve pressure before loosening or removing air system components. Failure to comply may result in injury or death to personnel.

- b. Inspect air lines between quick release valves and pneumatic controller for cracks and damage.

CONDITION/INDICATION

DO AIR LINES BETWEEN QUICK RELEASE VALVES AND PNEUMATIC CONTROLLER HAVE CRACKS OR OTHER DAMAGE?

DECISION

YES - Replace damaged air lines (Volume 5, WP 0805). Go to Step (23) to verify problem is solved.
NO - Go to Step (8).

TWO PRESSURE MODES INDICATED WITH STEADY MODE LIGHTS - Continued**STEP**

8. DO AIR LINES BETWEEN QUICK RELEASE VALVES AND PNEUMATIC CONTROLLER HAVE ANY AIR LEAKS?
 - a. Refer to point to point schematics.

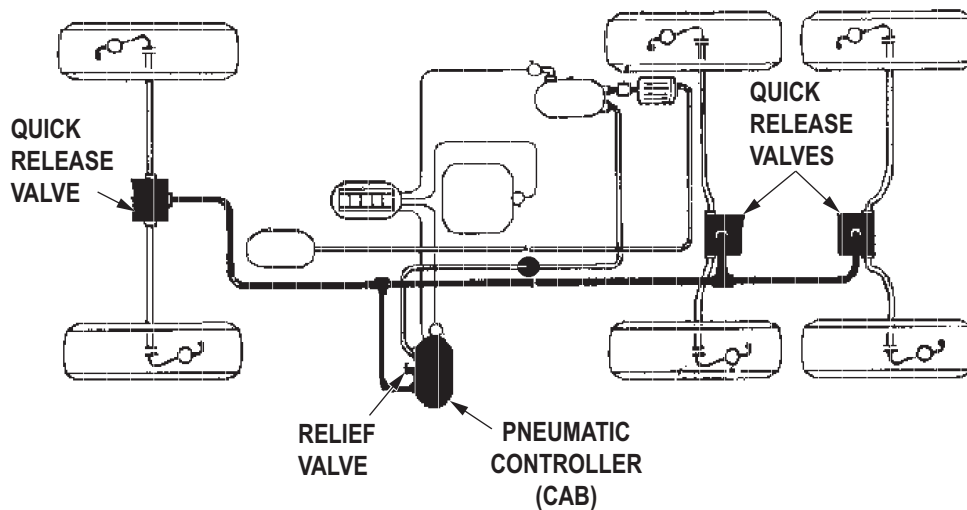

T0978DAA

Figure 6. Quick Release Valves And Pneumatic Controller.

- b. Use soapy water at connections to check for air leaks.

CONDITION/INDICATION

DO AIR LINES BETWEEN QUICK RELEASE VALVES AND PNEUMATIC CONTROLLER HAVE ANY AIR LEAKS?

DECISION

YES - Tighten loose tubing connections (Volume 5, WP 0805). Go to Step (23) to verify problem is solved.
 NO - Go to Step (9).

TWO PRESSURE MODES INDICATED WITH STEADY MODE LIGHTS - Continued

STEP

9. ARE AIR LINES BETWEEN QUICK RELEASE VALVES AND PNEUMATIC CONTROLLER RESTRICTED?
 - a. Refer to point to point schematics.

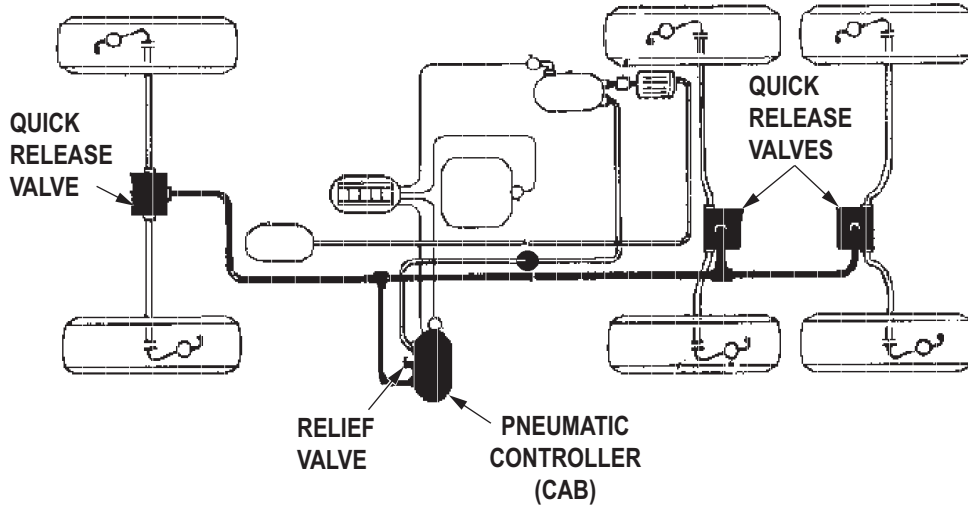

T0978DAA

Figure 7. Quick Release Valves And Pneumatic Controller.

WARNING

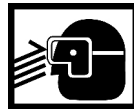

- Release all air pressure before loosening or removing air system component(s). Failure to comply may result in injury or death to personnel.
- Eyeshields must be worn when releasing compressed air. Failure to comply may result in injury or death to personnel.

- b. Disconnect air line at both ends.
- c. Check air line for restrictions.

CONDITION/INDICATION

ARE AIR LINES BETWEEN QUICK RELEASE VALVES AND PNEUMATIC CONTROLLER RESTRICTED?

DECISION

YES - Clear restriction, then reconnect air line (Volume 5, WP 0805). Go to Step (23) to verify problem is solved.
 NO - Go to Step (10).

TWO PRESSURE MODES INDICATED WITH STEADY MODE LIGHTS - Continued

STEP

10. DO AIR LINES BETWEEN QUICK RELEASE VALVES AND WHEEL VALVES HAVE CRACKS OR OTHER DAMAGE?
 - a. Refer to point to point schematics.

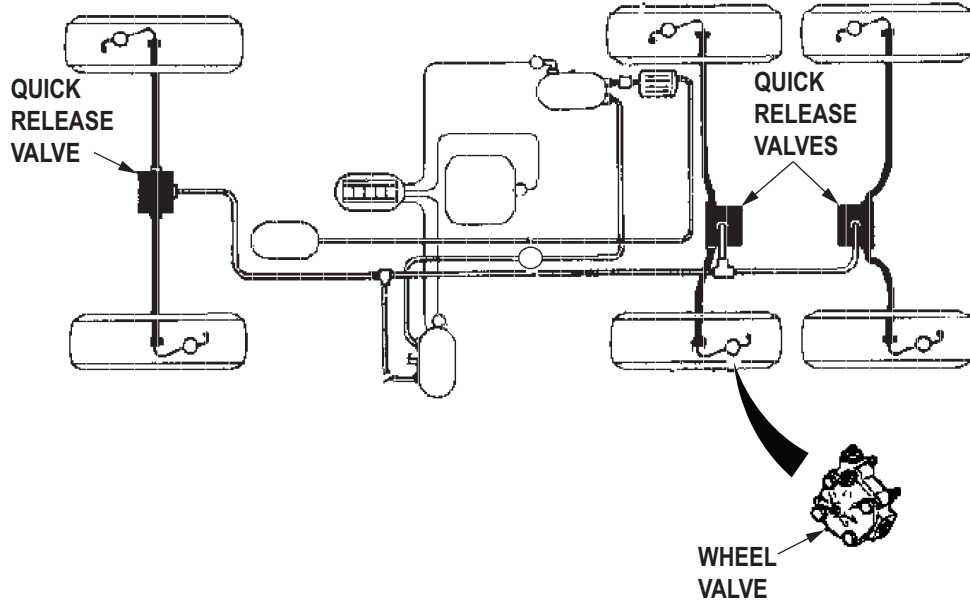

T0979DAA

Figure 8. Quick Release Valves And Wheel Valves.

WARNING

Air system components are subject to high pressure. Always relieve pressure before loosening or removing air system components. Failure to comply may result in injury or death to personnel.

- b. Inspect air lines between quick release valves and pneumatic controller for cracks and damage.

CONDITION/INDICATION

DO AIR LINES BETWEEN QUICK RELEASE VALVES AND WHEEL VALVES HAVE CRACKS OR OTHER DAMAGE?

DECISION

YES - Replace damaged air lines (Volume 5, WP 0805). Go to Step (23) to verify problem is solved.
 NO - Go to Step (11).

TWO PRESSURE MODES INDICATED WITH STEADY MODE LIGHTS - Continued

STEP

11. DO AIR LINES BETWEEN QUICK RELEASE VALVES AND WHEEL VALVES HAVE ANY AIR LEAKS?

a. Refer to point to point schematics.

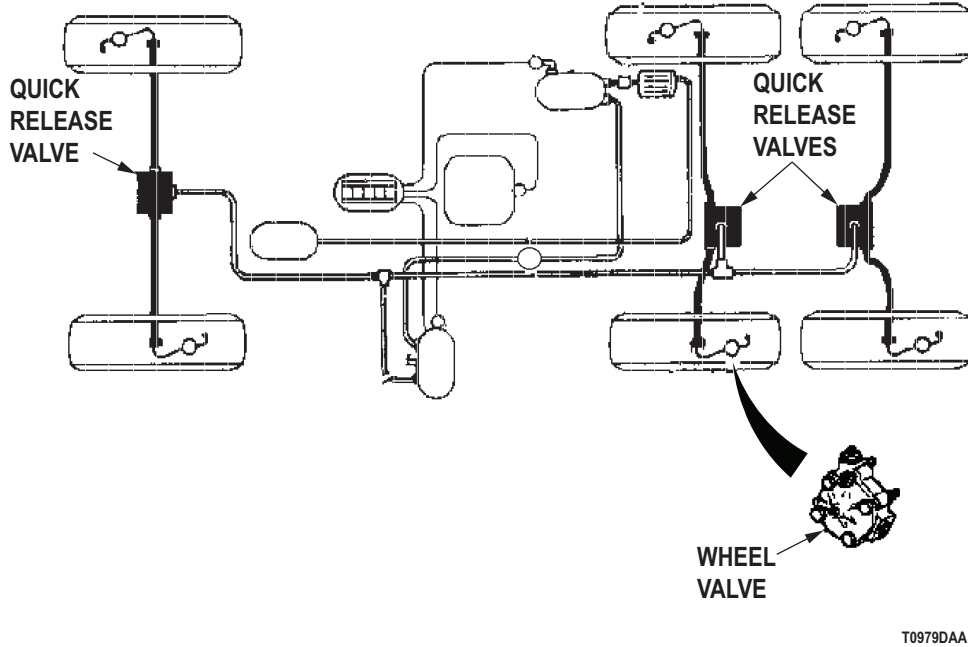

T0979DAA

Figure 9. Quick Release Valves And Wheel Valves.

b. Use soapy water at connections to check for air leaks.

CONDITION/INDICATION

DO AIR LINES BETWEEN QUICK RELEASE VALVES AND WHEEL VALVES HAVE ANY AIR LEAKS?

DECISION

YES - Tighten loose tubing connections (Volume 5, WP 0805). Go to Step (23) to verify problem is solved.

NO - Go to Step (12).

TWO PRESSURE MODES INDICATED WITH STEADY MODE LIGHTS - Continued**STEP**

12. ARE AIR LINES BETWEEN QUICK RELEASE VALVES AND WHEEL VALVES RESTRICTED?
- a. Refer to point to point schematics.

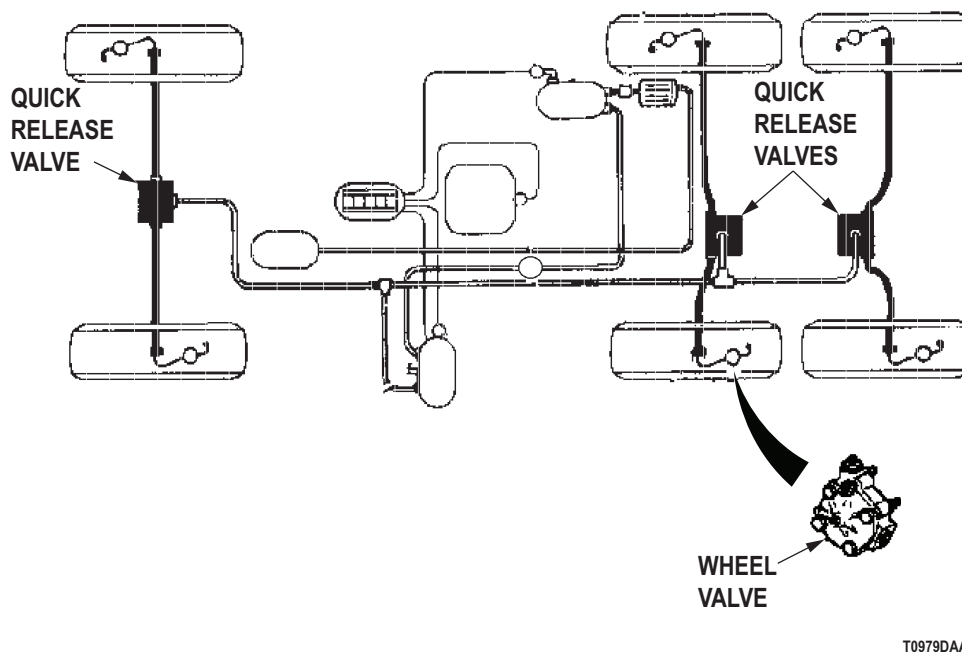

T0979DAA

Figure 10. Quick Release Valves And Wheel Valves.

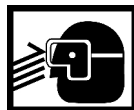
WARNING

- Release all air pressure before loosening or removing air system component(s). Failure to comply may result in injury or death to personnel.
- Eyeshields must be worn when releasing compressed air. Failure to comply may result in injury or death to personnel.

- b. Disconnect air line at both ends.
- c. Check air line for restrictions.

CONDITION/INDICATION

ARE AIR LINES BETWEEN QUICK RELEASE VALVES AND WHEEL VALVES RESTRICTED?

DECISION

YES - Clear restriction, then reconnect air line (Volume 5, WP 0805). Go to Step (23) to verify problem is solved.
 NO - Go to Step (13).

TWO PRESSURE MODES INDICATED WITH STEADY MODE LIGHTS - Continued**STEP****13. DO HUB AIR SEALS LEAK?**

Perform leak test (Volume 3, WP 0487) on hub air seals.

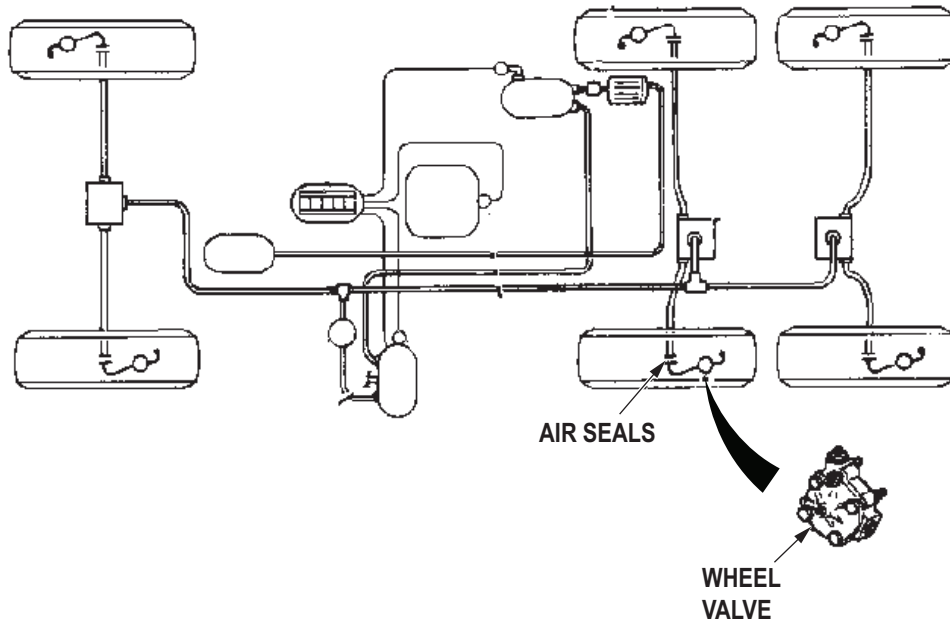

T0980DAA

Figure 11. Hub Air Seals.

CONDITION/INDICATION

DO HUB AIR SEALS LEAK?

DECISION

YES - Front air seals leak. Replace faulty seals (Volume 3, WP 0481). Go to Step (23) to verify problem is solved.

YES - Rear air seals leak. Replace faulty seals (Volume 3, WP 0482). Go to Step (23) to verify problem is solved.

NO - Go to Step (14).

TWO PRESSURE MODES INDICATED WITH STEADY MODE LIGHTS - Continued**STEP****14. IS THE PNEUMATIC CONTROLLER IN GOOD CONDITION?**

Listen for clicking noise while changing CTIS mode.

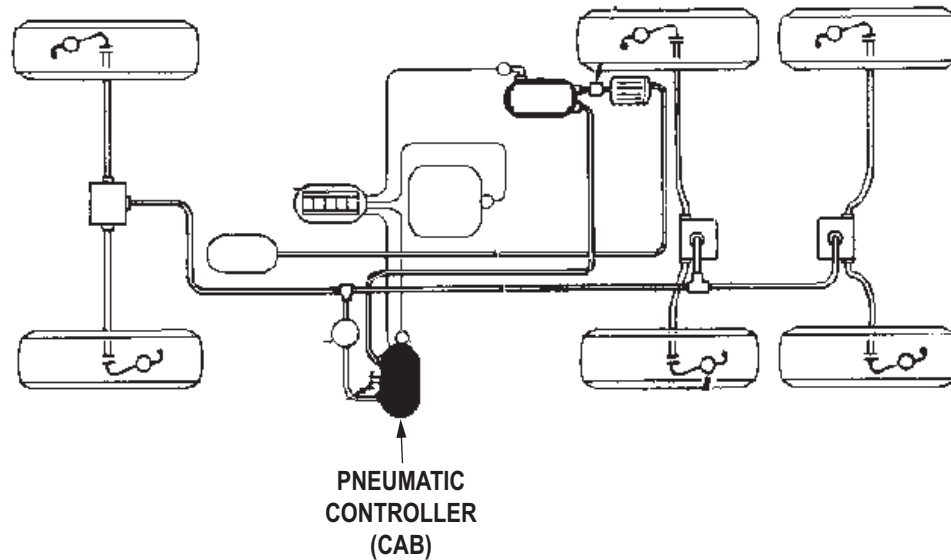

T0981DAA

Figure 12. Pneumatic Controller.

CONDITION/INDICATION

IS THE PNEUMATIC CONTROLLER IN GOOD CONDITION?

DECISION

YES - Clicking. Notify supervisor. Action may not be possible at this level of maintenance.

NO - Not clicking. Replace pneumatic controller (Volume 5, WP 0810). Go to Step (23) to verify problem is solved.

TWO PRESSURE MODES INDICATED WITH STEADY MODE LIGHTS - Continued

STEP

15. ARE THERE ANY CLOGGED QUICK RELEASE VALVES?

- a. Refer to point to point schematics.

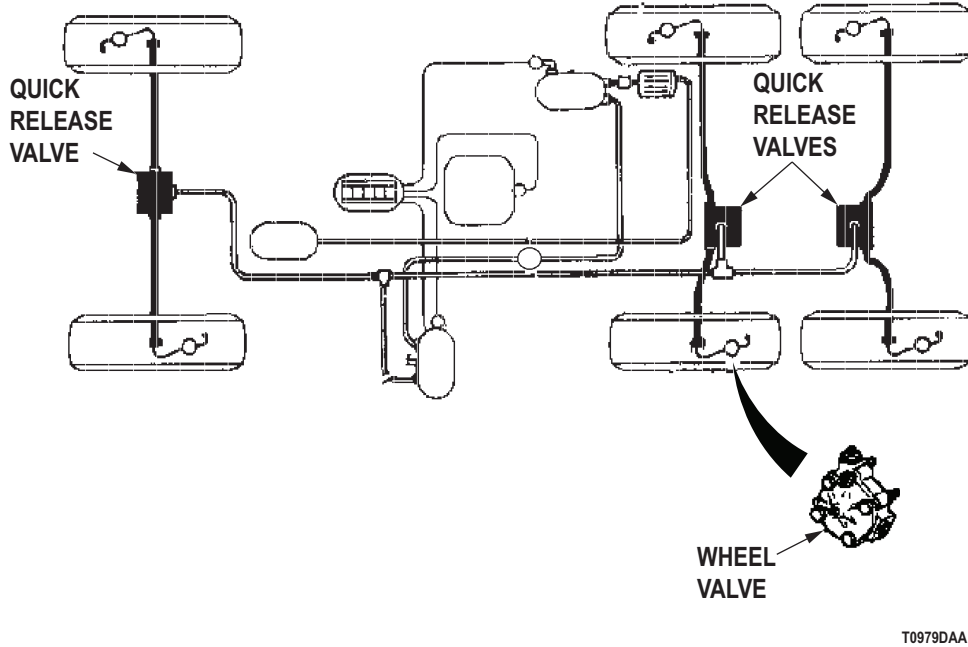
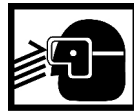

Figure 13. Quick Release Valves.

WARNING



- Release all air pressure before loosening or removing air system component(s). Failure to comply may result in injury or death to personnel.
- Eyeshields must be worn when releasing compressed air. Failure to comply may result in injury or death to personnel.

- b. Check quick release valves for obstructions.

CONDITION/INDICATION

ARE THERE ANY CLOGGED QUICK RELEASE VALVES?

DECISION

YES - Clear valves (Volume 5, WP 0809). Go to Step (23) to verify problem is solved.
 NO - Go to Step (16).

TWO PRESSURE MODES INDICATED WITH STEADY MODE LIGHTS - Continued

STEP

16. IS THERE AUDIBLE AIR FLOW FROM RELIEF VALVE ON PNEUMATIC CONTROLLER DURING DEFLATION?

- a. Refer to point to point schematics.

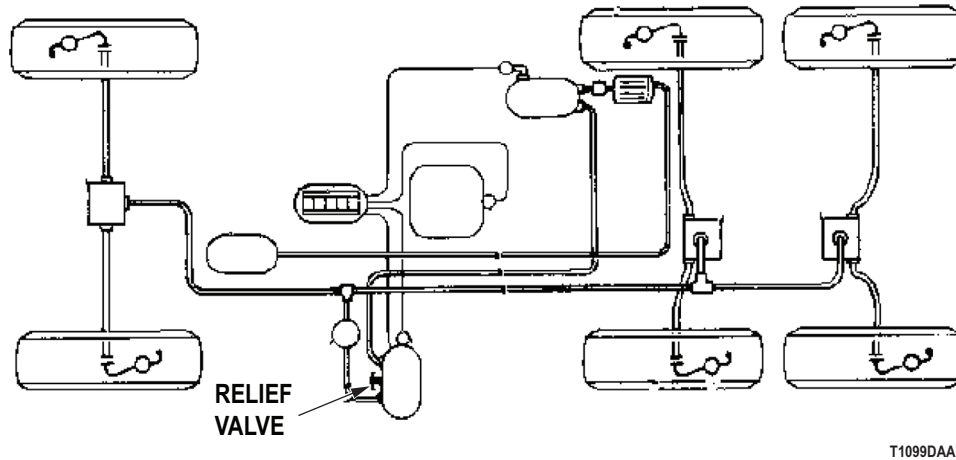

Figure 14. Relief Valve

- b. If air pressure is low, run engine at 1000 rpm for three to five minutes to build air supply to normal operating pressure.
- c. Stop engine.
- d. Check for continuous and audible air flow from relief valve on pneumatic controller during deflation.

CONDITION/INDICATION

IS THERE AUDIBLE AIR FLOW FROM RELIEF VALVE ON PNEUMATIC CONTROLLER DURING DEFLATION?

DECISION

YES - Go to Step (17).

NO - Replace faulty relief safety valve (Volume 5, WP 0810). Go to Step (23) to verify problem is solved.

TWO PRESSURE MODES INDICATED WITH STEADY MODE LIGHTS - Continued

STEP

17. IS THERE BATTERY VOLTAGE BETWEEN PINS X AND V ON CTIS WIRING HARNESS CANNON PLUG AT ECU?

- a. Turn battery switch to OFF position.

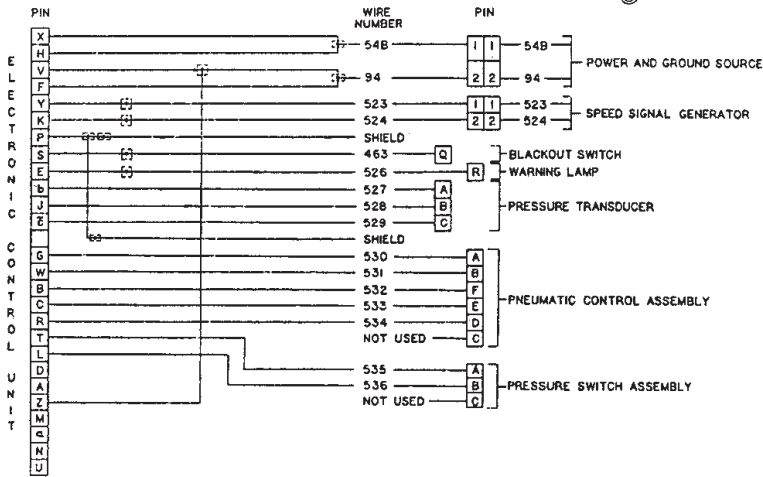
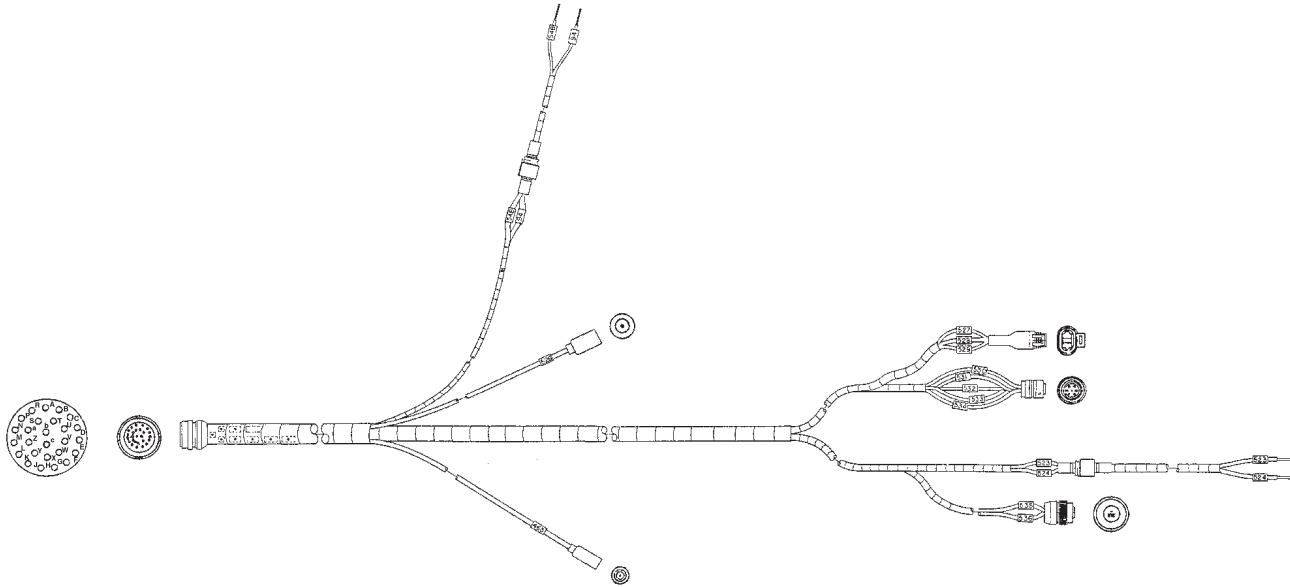

WIRING DIAGRAM

T0983DAA

Figure 15. CTIS Wiring Harness.

CAUTION

Turn battery switch to OFF position before disconnecting or connecting ECU wiring harness. Failure to do so may result in damage to ECU.

- b. Set multimeter to measure VDC.
- c. Disconnect CTIS wiring harness cannon plug at ECU.
- d. Turn battery switch to ON position.

TWO PRESSURE MODES INDICATED WITH STEADY MODE LIGHTS - Continued

- e. Connect multimeter red lead to CTIS wiring harness cannon plug pin X.
- f. Connect multimeter black lead to CTIS wiring harness cannon plug pin V.
- g. Meter reading should be between 18 and 26 VDC.

CONDITION/INDICATION

IS THERE BATTERY VOLTAGE BETWEEN PINS X AND V ON CTIS WIRING HARNESS CANNON PLUG AT ECU?

DECISION

- YES - Go to Step (18).
- NO - Perform Engine Fails To Crank troubleshooting (WP 0006).

STEP

- 18. DOES CTIS SYSTEM OPERATE CORRECTLY AFTER THE ELECTRICAL LEAD IS PROPERLY CONNECTED TO PRESSURE TRANSDUCER?
 - a. Turn battery switch to OFF position.

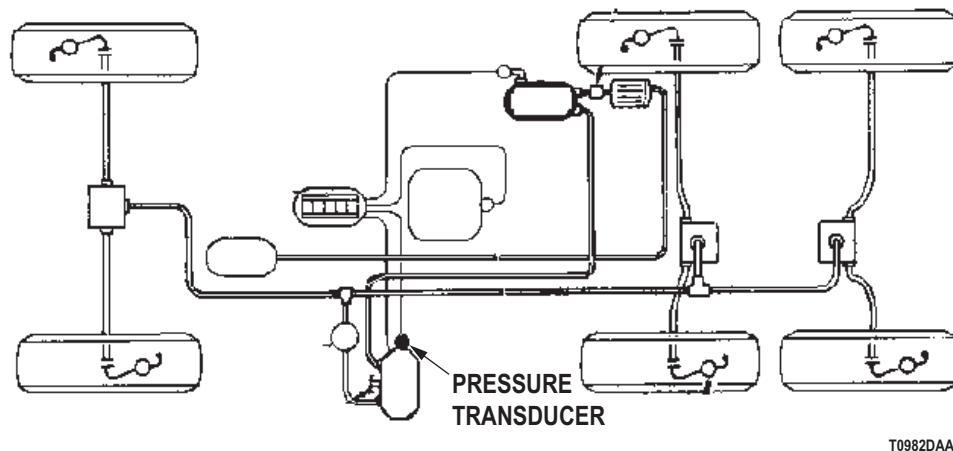

Figure 16. Pressure Transducer.

- b. Remove electrical lead from pressure transducer at pneumatic controller.
- c. Clean the connectors, then reconnect the lead.
- d. Check CTIS operation.

CONDITION/INDICATION

DOES CTIS SYSTEM OPERATE CORRECTLY AFTER THE ELECTRICAL LEAD IS PROPERLY CONNECTED TO PRESSURE TRANSDUCER?

DECISION

- YES - Go to Step (23) to verify problem is solved.
- NO - Go to Step (19).

TWO PRESSURE MODES INDICATED WITH STEADY MODE LIGHTS - Continued

STEP

19. IS THERE CONTINUITY BETWEEN PRESSURE TRANSDUCER AND ECU CANNON PLUG?

- a. Refer to point to point schematics.

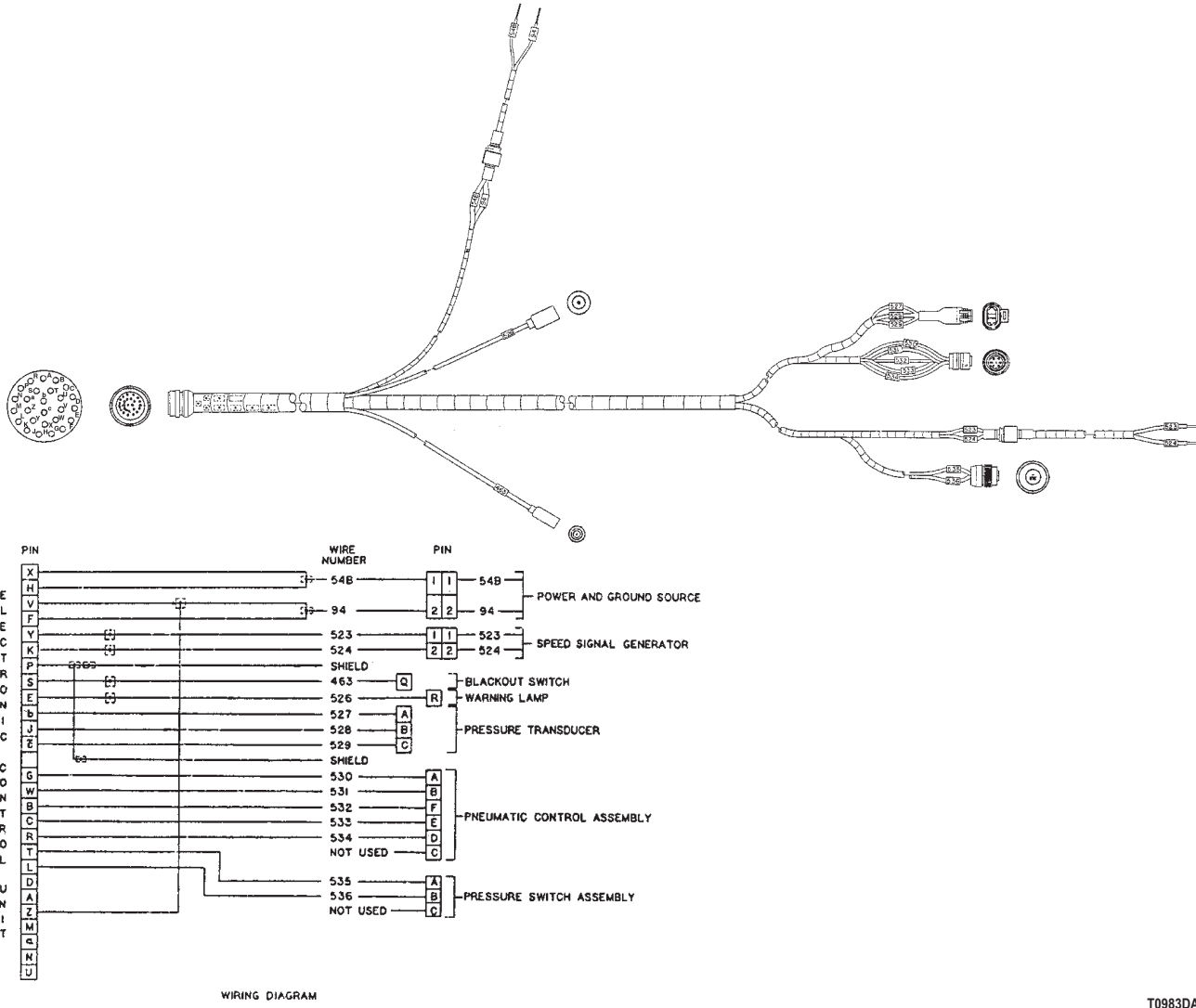

Figure 17. CTIS Wiring Harness.

- b. Connect CTIS wiring harness electrical lead to pressure transducer.
- c. Check connection of electrical lead at pressure transducer on pneumatic controller. Clean and tighten as needed.

CAUTION

Turn battery switch to OFF position before disconnecting or connecting ECU wiring harness. Failure to do so may result in damage to ECU.

TWO PRESSURE MODES INDICATED WITH STEADY MODE LIGHTS - Continued

- d. Turn battery switch to OFF position.
- e. Disconnect CTIS wiring harness cannon plug at ECU.
- f. Disconnect electrical lead at pressure transducer.
- g. Set multimeter to measure resistance.
- h. Connect multimeter red lead to pressure transducer.
- i. Connect multimeter black lead to pressure transducer lead at ECU cannon plug.
- j. Meter reading should be less than 200 ohms.

CONDITION/INDICATION

IS THERE CONTINUITY BETWEEN PRESSURE TRANSDUCER AND ECU CANNON PLUG?

DECISION

YES - Go to Step (20).

NO - Replace faulty CTIS wiring harness (Volume 2, WP 0322). Go to Step (23) to verify problem is solved.

TWO PRESSURE MODES INDICATED WITH STEADY MODE LIGHTS - Continued

STEP

20. IS THERE BATTERY VOLTAGE PRESENT AT PINS X AND V ON CTIS WIRING HARNESS CANNON PLUG AT ECU?

- a. Refer to point to point schematics.

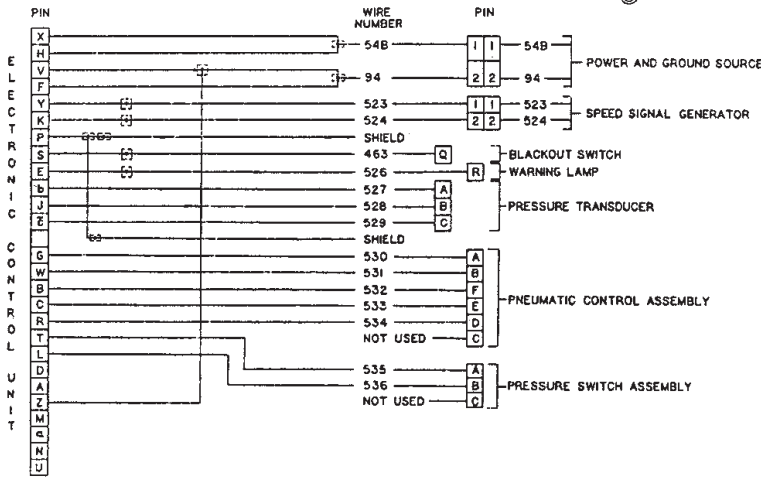
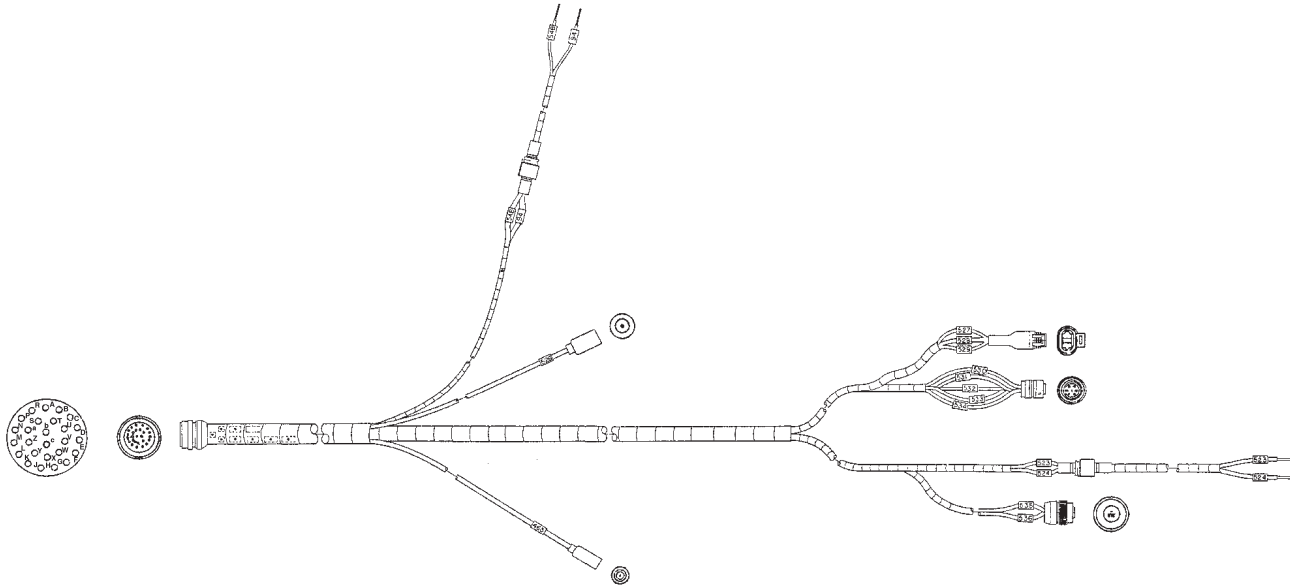

WIRING DIAGRAM

T0983DAA

Figure 18. CTIS Wiring Harness.

CAUTION

Turn battery switch to OFF position before disconnecting or connecting ECU wiring harness. Failure to do so may result in damage to ECU.

- b. Turn battery switch to OFF position.
- c. Disconnect CTIS wiring harness cannon plug at ECU.
- d. Set multimeter to measure VDC.

TWO PRESSURE MODES INDICATED WITH STEADY MODE LIGHTS - Continued

- e. Turn battery switch to ON position.
- f. Connect multimeter red lead to CTIS wiring harness cannon plug pin V.
- g. Connect multimeter black lead to CTIS wiring harness cannon plug pin X.
- h. Meter reading should be between 18 and 26 VDC.

CONDITION/INDICATION

IS THERE BATTERY VOLTAGE PRESENT AT PINS X AND V ON CTIS WIRING HARNESS CANNON PLUG AT ECU?

DECISION

YES - Go to Step (21).

NO - Perform Engine Fails To Crank troubleshooting (WP 0006).

TWO PRESSURE MODES INDICATED WITH STEADY MODE LIGHTS - Continued**STEP**

21. IS THERE 4.75 to 5.25 VDC PRESENT AT PRESSURE TRANSDUCER?

- a. Refer to point to point schematics.

CAUTION

Turn battery switch to OFF position before disconnecting or connecting ECU wiring harness. Failure to do so may result in damage to ECU.

- b. Turn battery switch to OFF position.
c. Connect CTIS wiring harness cannon plug at ECU.

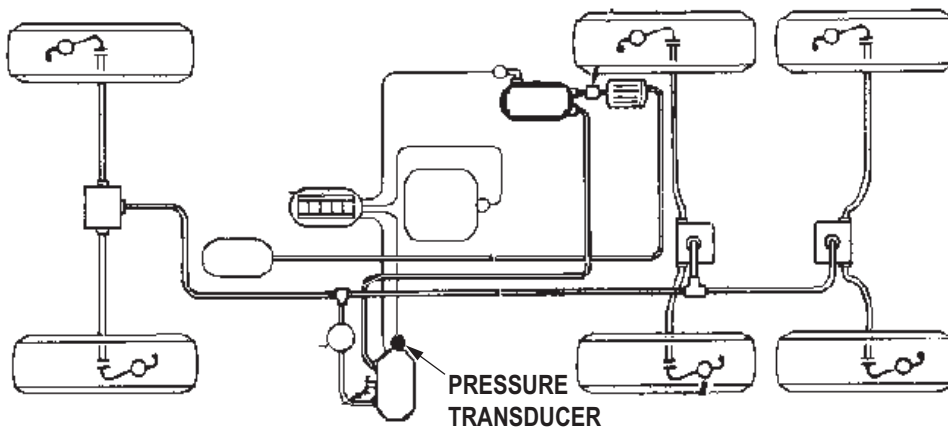

Figure 19. Pressure Transducer.

- d. Disconnect CTIS wiring harness electrical lead from pressure transducer.
e. Turn battery switch to ON position.
f. Connect multimeter red lead to wire at pressure transducer.
g. Connect multimeter black lead to a known good ground.
h. Meter reading should be between 4.75 and 5.25 VDC.

CONDITION/INDICATION

IS THERE 4.75 to 5.25 VDC PRESENT AT PRESSURE TRANSDUCER?

DECISION

YES - Replace pressure transducer (Volume 5, WP 0812). Go to Step (23) to verify problem is solved.
NO - Go to Step (22).

TWO PRESSURE MODES INDICATED WITH STEADY MODE LIGHTS - Continued

STEP

22. IS THE PNEUMATIC CONTROLLER IN GOOD CONDITION?

Listen for clicking noise while changing CTIS mode.

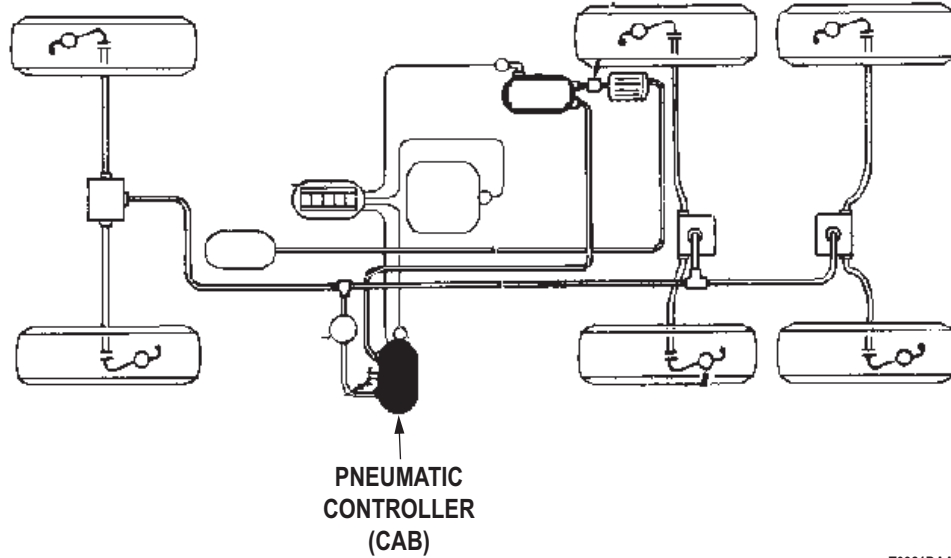

T0981DAA

Figure 20. Pneumatic Controller.

CONDITION/INDICATION

IS THE PNEUMATIC CONTROLLER IN GOOD CONDITION?

DECISION

- YES - Replace electronic control unit (Volume 5, WP 0813). Go to Step (23) to verify problem is solved.
- NO - Replace or repair pneumatic controller (Volume 5, WP 0810). Go to Step (23) to verify problem is solved.

STEP

23. IS YOUR ORIGINAL PROBLEM STILL PRESENT?

- a. Ensure vehicle is returned to normal operating condition.
- b. Check to see if your original problem still exists.

CONDITION/INDICATION

IS YOUR ORIGINAL PROBLEM STILL PRESENT?

DECISION

- YES - Notify supervisor.
- NO - Problem fixed.

END OF WORK PACKAGE

**FIELD MAINTENANCE
FOUR PRESSURE MODE LIGHTS FLASHING**

INITIAL SETUP:**Tools and Special Tools**

Tool Kit, General Mechanic's: Automotive
(Volume 5, WP 0826, Table 1, Item 56)
Goggles, Industrial
(Volume 5, WP 0826, Table 1, Item 20)
Multimeter
(Volume 5, WP 0826, Table 1, Item 34)
Soap Solution
Test Set, Electronic Systems
(Volume 5, WP 0826, Table 1, Item 51)

References (cont.)

TM 9-2320-272-10
Volume 3, WP 0481
Volume 3, WP 0482
Volume 3, WP 0487
Volume 3, WP 0490
Volume 3, WP 0491
Volume 5, WP 0805
Volume 5, WP 0810
Volume 5, WP 0813

Personnel Required

(2)

Equipment Condition

Vehicle parked and engine shut down.
(TM 9-2320-272-10)

References

Point to Point Schematics

TROUBLESHOOTING PROCEDURE**FOUR PRESSURE MODE LIGHTS FLASHING****NOTE**

Conduct these malfunction tests if four pressure mode lights flash. This procedure will check for a problem with air lines between wheel valves and wheel rims, and between quick release valves and pneumatic controller. It will also check for a faulty wheel valve, hub air seal, and pneumatic controller.

FOUR PRESSURE MODE LIGHTS FLASHING - Continued

STEP

1. DO AIR LINES BETWEEN WHEEL VALVE AND WHEEL RIM HAVE CRACKS OR OTHER DAMAGE?
 - a. Measure and record pressure of each tire (TM 9-2320-272-10).

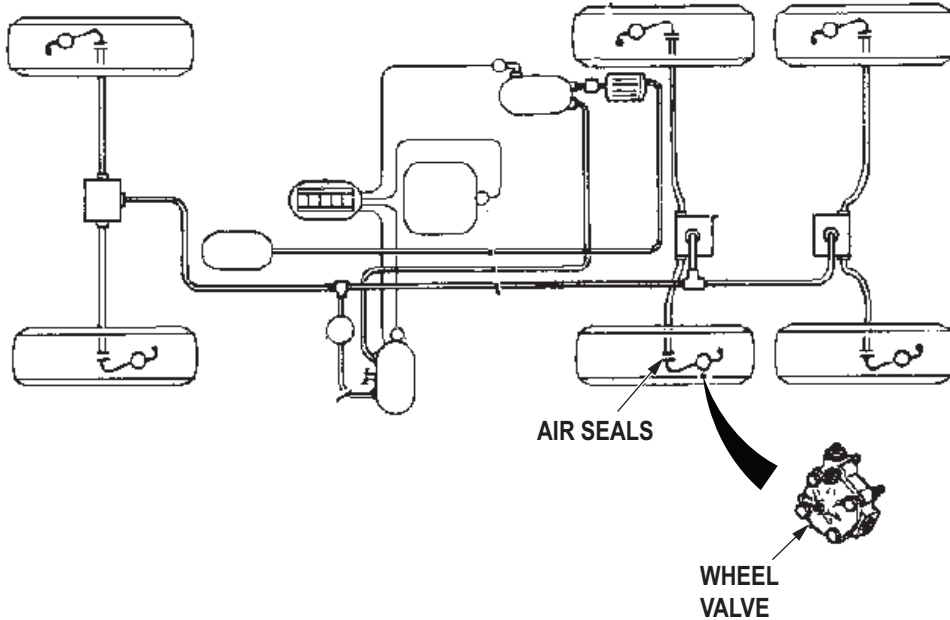

T0419DAA

Figure 1. Wheel Valve.

- b. Refer to point to point schematics.

WARNING

Air system components are subject to high pressure. Always relieve pressure before loosening or removing air system components. Failure to comply may result in injury or death to personnel.

- c. For all tires significantly outside pressure limits, inspect air lines between wheel valve and wheel rim for cracks and damage.

CONDITION/INDICATION

DO AIR LINES BETWEEN WHEEL VALVE AND WHEEL RIM HAVE CRACKS OR OTHER DAMAGE?

DECISION

- YES - Front air lines damaged. Replace damaged air line (Volume 3, WP 0490). Go to Step (10) to verify problem is solved.
- YES - Rear air lines are damaged. Replace damaged air line (Volume 3, WP 0491). Go to Step (10) to verify problem is solved.
- NO - Go to Step (2).

FOUR PRESSURE MODE LIGHTS FLASHING - Continued

STEP

2. DO AIR LINES BETWEEN WHEEL VALVE AND WHEEL RIM HAVE ANY AIR LEAKS?
 - a. Refer to point to point schematics.

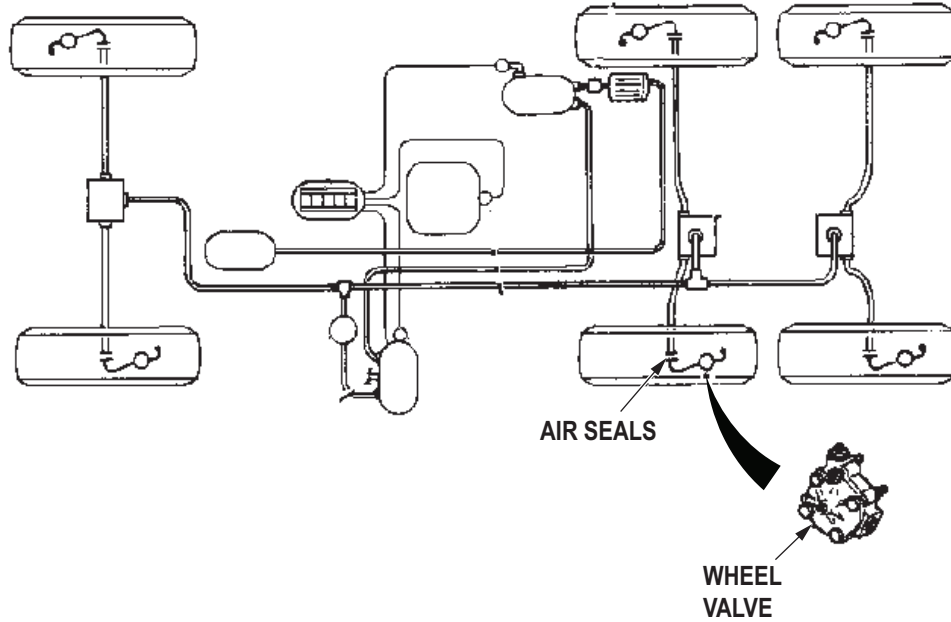

T0419DAA

Figure 2. Wheel Valve.

- b. For all tires previously found to be significantly outside pressure limits, use soapy water at air line wheel valve and wheel rim connections to check for leaks.

CONDITION/INDICATION

DO AIR LINES BETWEEN WHEEL VALVE AND WHEEL RIM HAVE ANY AIR LEAKS?

DECISION

- YES - Front air lines leak. Replace damaged air line (Volume 3, WP 0490). Go to Step (10) to verify problem is solved.
- YES - Rear air lines leak. Replace damaged air line (Volume 3, WP 0491). Go to Step (10) to verify problem is solved.
- NO - Go to Step (3).

FOUR PRESSURE MODE LIGHTS FLASHING - Continued**STEP****3. ARE AIR LINES BETWEEN WHEEL VALVE AND WHEEL RIM RESTRICTED?**

- a. Refer to point to point schematics.

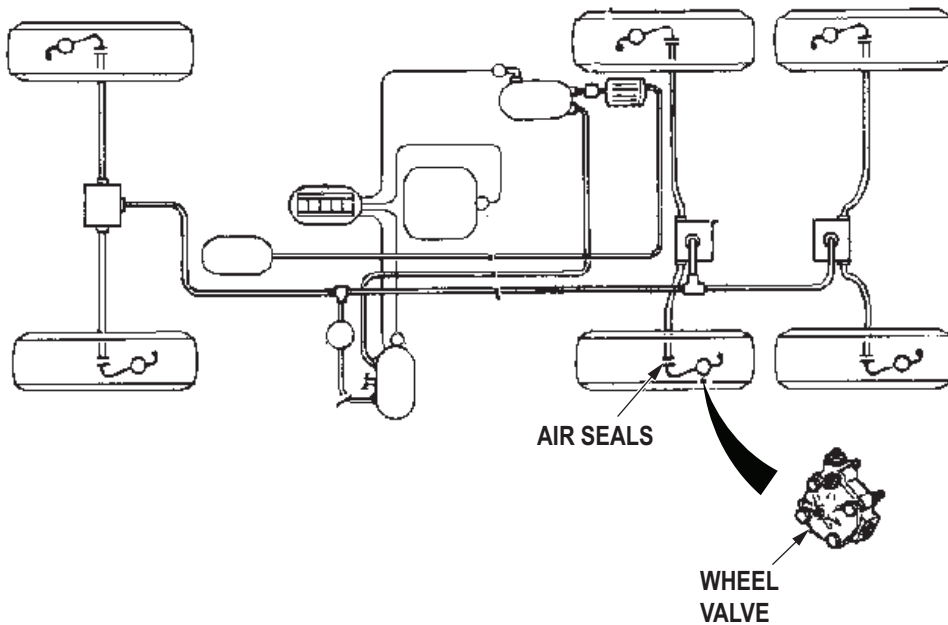

T0419DAA

Figure 3. Wheel Valve.

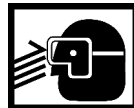
WARNING

- Release all air pressure before loosening or removing air system component(s). Failure to comply may result in injury or death to personnel.
 - Eyeshields must be worn when releasing compressed air. Failure to comply may result in injury or death to personnel.
- b. For all tires significantly outside pressure limits, inspect front wheel air lines and rear wheel air lines between wheel valve and wheel rim for restrictions.

FOUR PRESSURE MODE LIGHTS FLASHING - Continued**CONDITION/INDICATION**

ARE AIR LINES BETWEEN WHEEL VALVE AND WHEEL RIM RESTRICTED?

DECISION

YES - Front air lines restricted. Clear restrictions or replace damaged air line (Volume 3, WP 0490). Go to Step (10) to verify problem is solved.

YES - Rear air lines restricted. Clear restrictions or replace damaged air line (Volume 3, WP 0491). Go to Step (10) to verify problem is solved.

NO - Go to Step (4).

FOUR PRESSURE MODE LIGHTS FLASHING - Continued

STEP

4. DOES WHEEL VALVE LEAK AIR?

- a. Refer to point to point schematics.

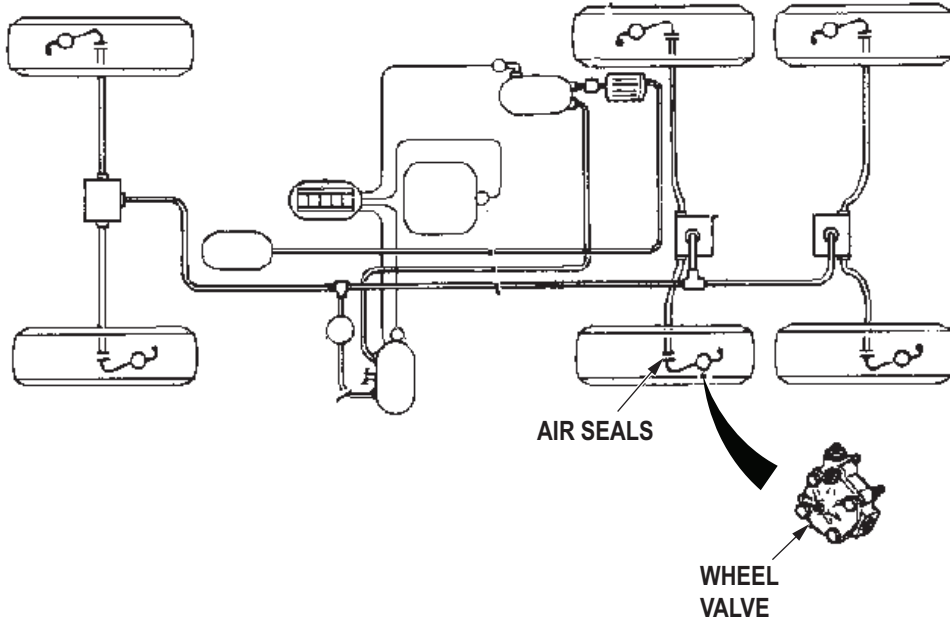

T0419DAA

Figure 4. Wheel Valve.

WARNING

Air system components are subject to high pressure. Always relieve pressure before loosening or removing air system components. Failure to comply may result in injury or death to personnel.

NOTE

To determine a wheel valve air leak, with wheel valve still connected to tire, check for air leak at quick release valves. Determine which valve is leaking, by disconnecting air line at quick release valve to either feel or listen for air escaping.

- b. Check for air leak at the quick release valves.

CONDITION/INDICATION

DOES WHEEL VALVE LEAK AIR?

DECISION

- YES - Front wheel valve leaks. Replace wheel valve (Volume 3, WP 0490). Go to Step (10) to verify problem is solved.
- YES - Rear wheel valve leaks. Replace wheel valve (Volume 3, WP 0491). Go to Step (10) to verify problem is solved.
- NO - Go to Step (5).

FOUR PRESSURE MODE LIGHTS FLASHING - Continued**STEP**

5. DO AIR LINES BETWEEN QUICK RELEASE VALVES AND PNEUMATIC CONTROLLER HAVE CRACKS OR OTHER DAMAGE?
 - a. Refer to point to point schematics.

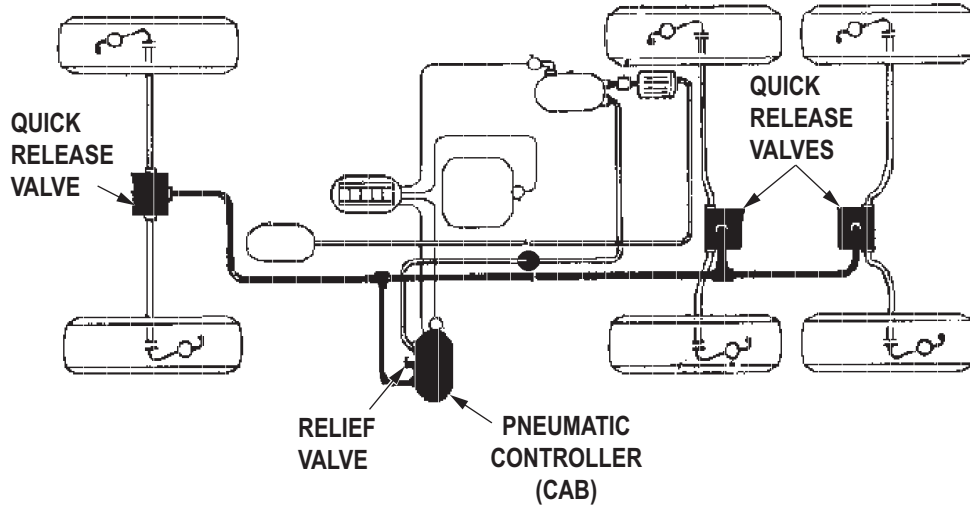

T0416DAA

Figure 5. Quick Release Valves And Pneumatic Controller.

WARNING

Air system components are subject to high pressure. Always relieve pressure before loosening or removing air system components. Failure to comply may result in injury or death to personnel.

- b. Inspect air lines between quick release valves and pneumatic controller for cracks and damage.

CONDITION/INDICATION

DO AIR LINES BETWEEN QUICK RELEASE VALVES AND PNEUMATIC CONTROLLER HAVE CRACKS OR OTHER DAMAGE?

DECISION

YES - Replace damaged air lines (Volume 5, WP 0805). Go to Step (10) to verify problem is solved.
 NO - Go to Step (6).

FOUR PRESSURE MODE LIGHTS FLASHING - Continued

STEP

6. DO AIR LINES BETWEEN QUICK RELEASE VALVES AND PNEUMATIC CONTROLLER HAVE ANY AIR LEAKS?
 - a. Refer to point to point schematics.

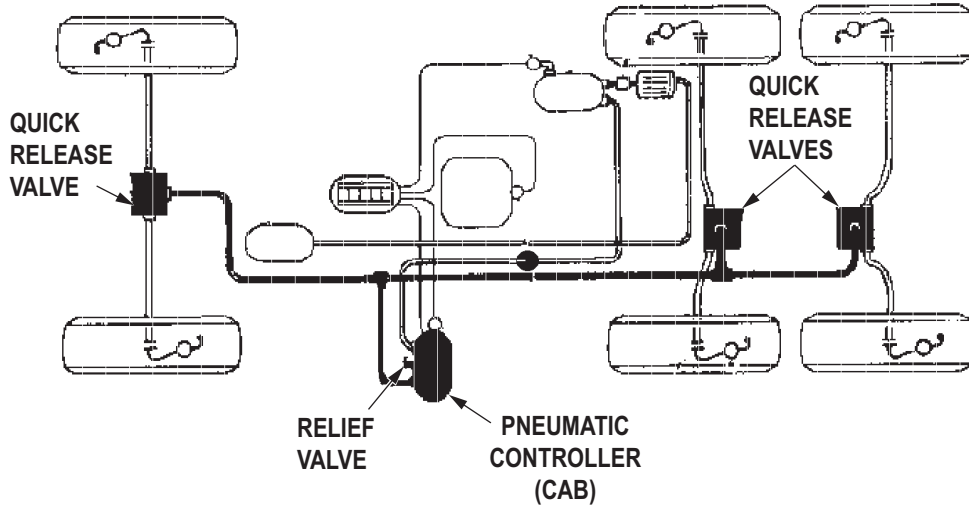

T0416DAA

Figure 6. Quick Release Valves And Pneumatic Controller.

- b. Use soapy water at connections to check for air leaks.

CONDITION/INDICATION

DO AIR LINES BETWEEN QUICK RELEASE VALVES AND PNEUMATIC CONTROLLER HAVE ANY AIR LEAKS?

DECISION

YES - Tighten loose tubing connections (Volume 5, WP 0805). Go to Step (10) to verify problem is solved.
 NO - Go to Step (7).

FOUR PRESSURE MODE LIGHTS FLASHING - Continued

STEP

7. ARE AIR LINES BETWEEN QUICK RELEASE VALVES AND PNEUMATIC CONTROLLER RESTRICTED?
 - a. Refer to point to point schematics.

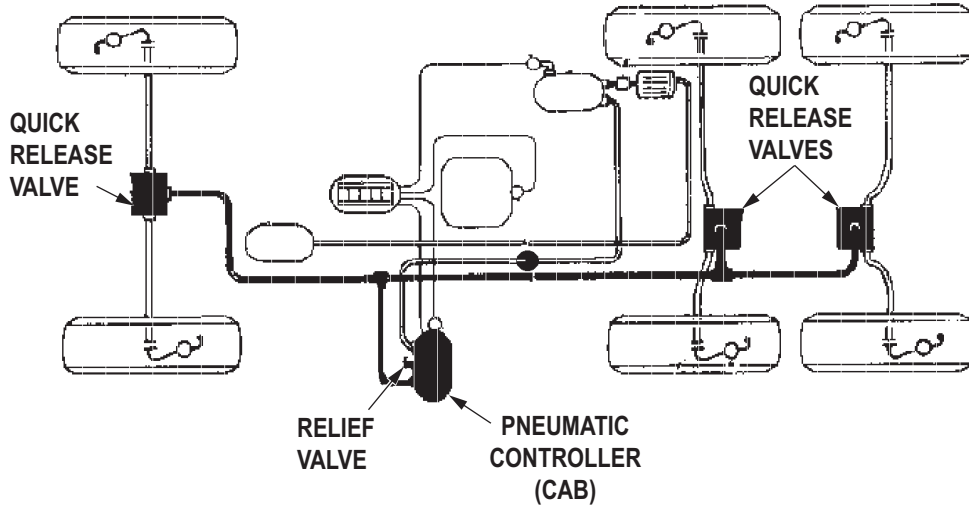

T0416DAA

Figure 7. Quick Release Valves And Pneumatic Controller.

WARNING

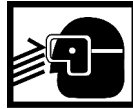

- Release all air pressure before loosening or removing air system component(s). Failure to comply may result in injury or death to personnel.
- Eyeshields must be worn when releasing compressed air. Failure to comply may result in injury or death to personnel.

- b. Disconnect air line at both ends.
- c. Check air line for restrictions.

CONDITION/INDICATION

ARE AIR LINES BETWEEN QUICK RELEASE VALVES AND PNEUMATIC CONTROLLER RESTRICTED?

DECISION

YES - Clear restriction, then reconnect air line (Volume 5, WP 0805). Go to Step (10) to verify problem is solved.
 NO - Go to Step (8).

FOUR PRESSURE MODE LIGHTS FLASHING - Continued

STEP

8. DO HUB AIR SEALS LEAK?

NOTE

In extreme cold temperature hub seals may leak. Drive vehicle to ensure hub seals are at operating temperature.

Perform leak test (Volume 3, WP 0487) on hub air seals.

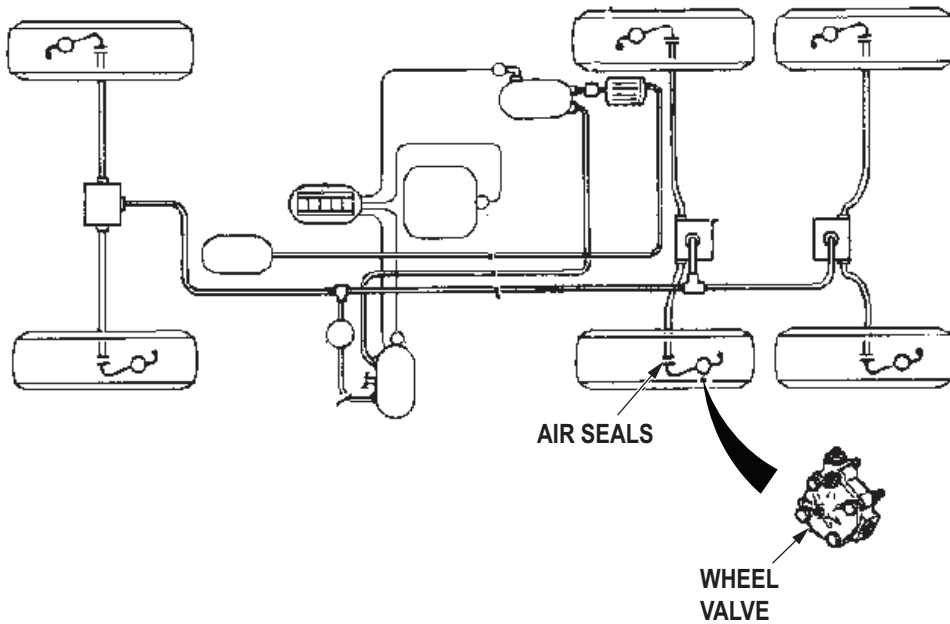

Figure 8. Hub Air Seals.

CONDITION/INDICATION

DO HUB AIR SEALS LEAK?

DECISION

YES - Front air seals leak. Replace faulty air seals (Volume 3, WP 0481). Go to Step (10) to verify problem is solved.

YES - Rear air seals leak. Replace faulty air seals (Volume 3, WP 0482). Go to Step (10) to verify problem is solved.

NO - Go to Step (9).

FOUR PRESSURE MODE LIGHTS FLASHING - Continued

STEP

9. IS THE PNEUMATIC CONTROLLER IN GOOD CONDITION?

Listen for clicking noise while changing CTIS mode.

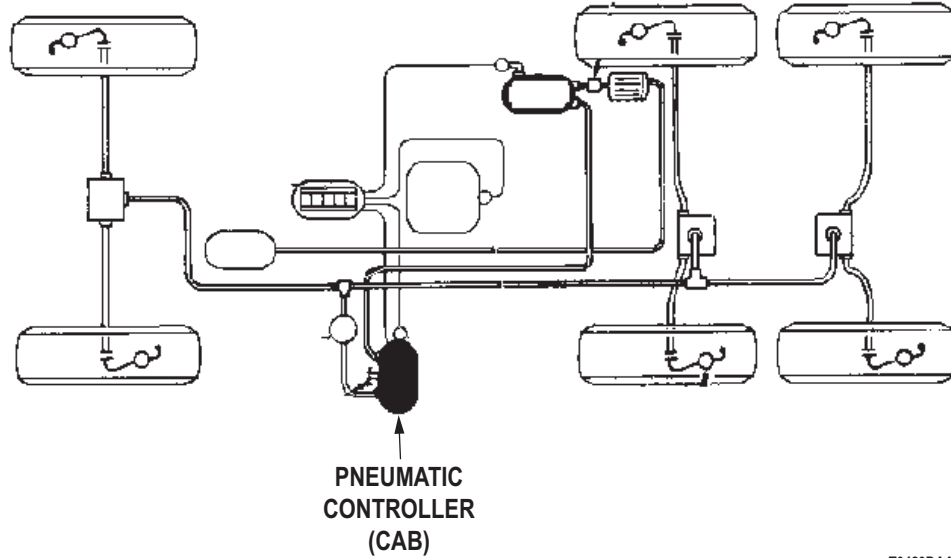

T0420DAA

Figure 9. Pneumatic Controller.

CONDITION/INDICATION

IS THE PNEUMATIC CONTROLLER IN GOOD CONDITION?

DECISION

YES - Replace electronic control unit (Volume 5, WP 0813). Go to Step (10) to verify problem is solved.
 NO - Replace pneumatic controller (Volume 5, WP 0810). Go to Step (10) to verify problem is solved.

STEP

10. IS YOUR ORIGINAL PROBLEM STILL PRESENT?

- a. Ensure vehicle is returned to normal operating condition.
- b. Check to see if your original problem still exists.

CONDITION/INDICATION

IS YOUR ORIGINAL PROBLEM STILL PRESENT?

DECISION

YES - Notify supervisor.
 NO - Problem fixed.

END OF WORK PACKAGE

**FIELD MAINTENANCE
FIVE INDICATOR LIGHTS FLASHING**

INITIAL SETUP:**Tools and Special Tools**

Tool Kit, General Mechanic's: Automotive
(Volume 5, WP 0826, Table 1, Item 56)
Goggles, Industrial
(Volume 5, WP 0826, Table 1, Item 20)
Multimeter
(Volume 5, WP 0826, Table 1, Item 34)
Soap Solution
Test Set, Electronic Systems
(Volume 5, WP 0826, Table 1, Item 51)

References (cont.)

WP 0006
Volume 2, WP 0322
Volume 2, WP 0324
Volume 5, WP 0813
Volume 5, WP 0810
Volume 5, WP 0812

Equipment Condition

Vehicle parked and engine shut down.
(TM 9-2320-272-10)

Personnel Required

(2)

References

Point to Point Schematics

TROUBLESHOOTING PROCEDURE**FIVE INDICATOR LIGHTS FLASHING****NOTE**

- Conduct these malfunction tests if five indicator lights flash. This procedure will check for a problem with air lines between quick release valves and pneumatic controller, and between wheel and quick release valves. It will also check for a faulty hub air seal, pneumatic controller, electrical lead on pressure switch at wet tank, CTIS wiring harness, pressure switch, ECU and pressure transducer.
- The ECU has a self-diagnostic capability which prevents operation of the CTIS when key elements or components of the system malfunction. When the ECU shuts down due to such system malfunction, the condition will be indicated by the flashing of all five mode lights on ECU selector panel. Since it is unlikely that the CTIS would operate properly, there is no option to override the ECU until the problem is corrected. An indication of five flashing lights can be caused by any of four conditions: 1) Faulty air line to tires; 2) Faulty pneumatic controller; 3) Faulty pressure switch circuit; 4) Faulty pressure transducer circuit.

FIVE INDICATOR LIGHTS FLASHING - Continued

STEP

1. DO AIR LINES BETWEEN QUICK RELEASE VALVES AND PNEUMATIC CONTROLLER HAVE CRACKS OR OTHER DAMAGE?
 - a. Refer to point to point schematics.

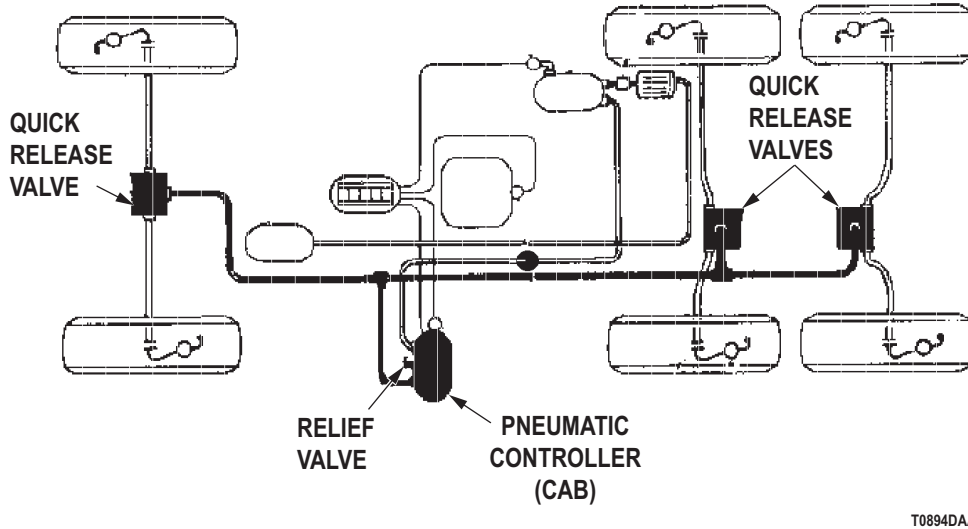

T0894DAA

Figure 1. Quick Release Valves And Pneumatic Controller.

WARNING

Air system components are subject to high pressure. Always relieve pressure before loosening or removing air system components. Failure to comply may result in injury or death to personnel.

- b. Inspect air lines between quick release valves and pneumatic controller for cracks and damage.

CONDITION/INDICATION

DO AIR LINES BETWEEN QUICK RELEASE VALVES AND PNEUMATIC CONTROLLER HAVE CRACKS OR OTHER DAMAGE?

DECISION

- YES - Replace damaged air lines (Volume 5, WP 0805). Go to Step (17) to verify problem is solved.
- NO - Go to Step (2).

FIVE INDICATOR LIGHTS FLASHING - Continued

STEP

2. DO AIR LINES BETWEEN QUICK RELEASE VALVES AND PNEUMATIC CONTROLLER HAVE ANY AIR LEAKS?
 - a. Refer to point to point schematics.

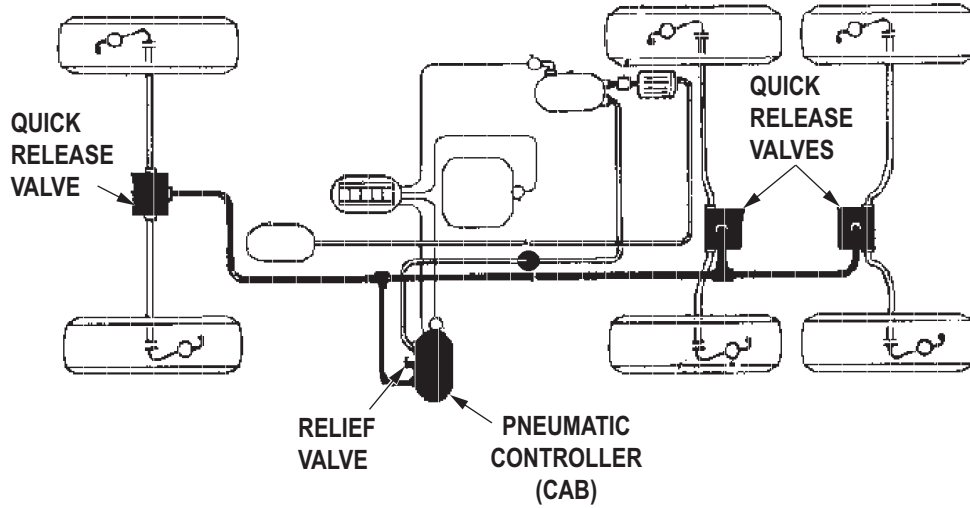

T0894DAA

Figure 2. Quick Release Valves And Pneumatic Controller.

- b. Use soapy water at connections to check for air leaks.

CONDITION/INDICATION

DO AIR LINES BETWEEN QUICK RELEASE VALVES AND PNEUMATIC CONTROLLER HAVE ANY AIR LEAKS?

DECISION

YES - Tighten loose tubing connections (Volume 5, WP 0805). Go to Step (17) to verify problem is solved.
 NO - Go to Step (3).

FIVE INDICATOR LIGHTS FLASHING - Continued

STEP

3. ARE AIR LINES BETWEEN QUICK RELEASE VALVES AND PNEUMATIC CONTROLLER RESTRICTED?
 - a. Refer to point to point schematics.

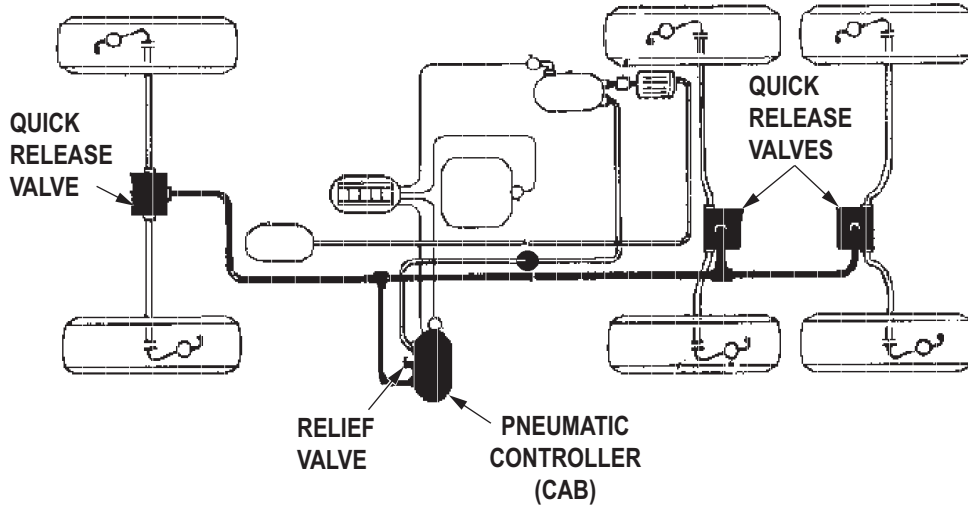

T0894DAA

Figure 3. Quick Release Valves and Pneumatic Controller.

WARNING

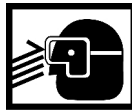

- Release all air pressure before loosening or removing air system component(s). Failure to comply may result in injury or death to personnel.
- Eyeshields must be worn when releasing compressed air. Failure to comply may result in injury or death to personnel.

- b. Disconnect air line at both ends.
- c. Check air line for restrictions.

CONDITION/INDICATION

ARE AIR LINES BETWEEN QUICK RELEASE VALVES AND PNEUMATIC CONTROLLER RESTRICTED?

DECISION

YES - Clear restriction, then reconnect air line (Volume 5, WP 0805). Go to Step (17) to verify problem is solved.
 NO - Go to Step (4).

FIVE INDICATOR LIGHTS FLASHING - Continued

STEP

4. DO AIR LINES BETWEEN QUICK RELEASE VALVES AND WHEEL VALVES HAVE CRACKS OR OTHER DAMAGE?
 - a. Refer to point to point schematics.

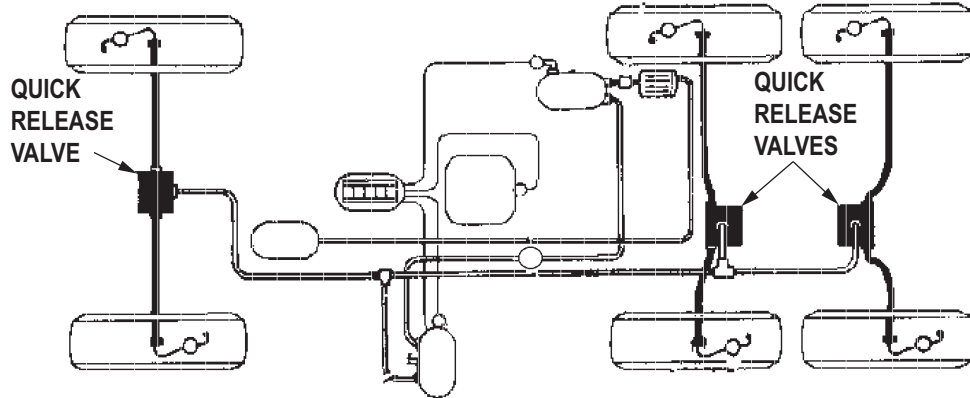

Figure 4. Quick Release Valves And Wheel Valves.

WARNING

Air system components are subject to high pressure. Always relieve pressure before loosening or removing air system components. Failure to comply may result in injury or death to personnel.

- b. Inspect air lines between quick release valves and pneumatic controller for cracks and damage.

CONDITION/INDICATION

DO AIR LINES BETWEEN QUICK RELEASE VALVES AND WHEEL VALVES HAVE CRACKS OR OTHER DAMAGE?

DECISION

- YES - Replace damaged air lines (Volume 5, WP 0805). Go to Step (17) to verify problem is solved.
 NO - Go to Step (5).

FIVE INDICATOR LIGHTS FLASHING - Continued**STEP**

5. DO AIR LINES BETWEEN QUICK RELEASE VALVES AND WHEEL VALVES HAVE ANY AIR LEAKS?
 - a. Refer to point to point schematics.

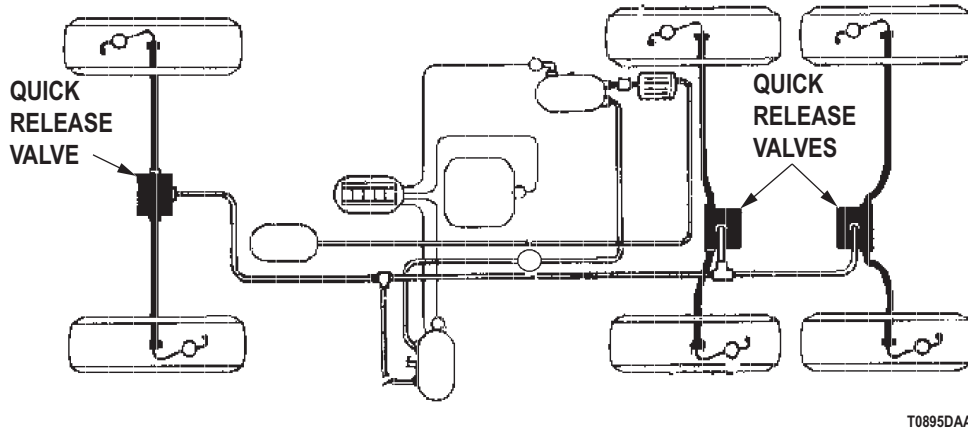

Figure 5. Quick Release Valves and Wheel Valves.

- b. Use soapy water at connections to check for air leaks.

CONDITION/INDICATION

DO AIR LINES BETWEEN QUICK RELEASE VALVES AND WHEEL VALVES HAVE ANY AIR LEAKS?

DECISION

YES - Tighten loose tubing connections (Volume 5, WP 0805). Go to Step (17) to verify problem is solved.
 NO - Go to Step (6).

FIVE INDICATOR LIGHTS FLASHING - Continued

STEP

6. ARE AIR LINES BETWEEN QUICK RELEASE VALVES AND WHEEL VALVES RESTRICTED?
 - a. Refer to point to point schematics.

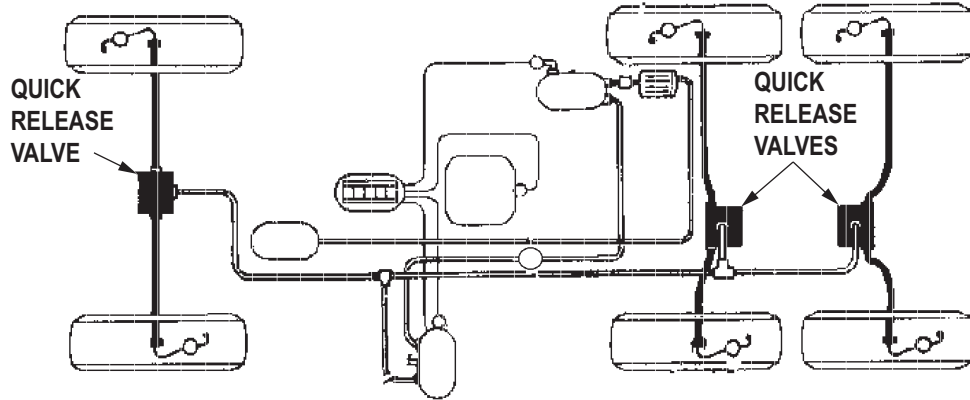

T0895DAA

Figure 6. Quick Release Valves and Wheel Valves.

WARNING

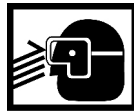

- Release all air pressure before loosening or removing air system component(s). Failure to comply may result in injury or death to personnel.
- Eyeshields must be worn when releasing compressed air. Failure to comply may result in injury or death to personnel.

- b. Disconnect air line at both ends.
- c. Check air line for restrictions.

CONDITION/INDICATION

ARE AIR LINES BETWEEN QUICK RELEASE VALVES AND WHEEL VALVES RESTRICTED?

DECISION

YES - Clear restriction, then reconnect air line (Volume 5, WP 0805). Go to Step (17) to verify problem is solved.
 NO - Go to Step (7).

FIVE INDICATOR LIGHTS FLASHING - Continued**STEP****7. IS THE PNEUMATIC CONTROLLER IN GOOD CONDITION?**

Listen for clicking noise while changing CTIS mode.

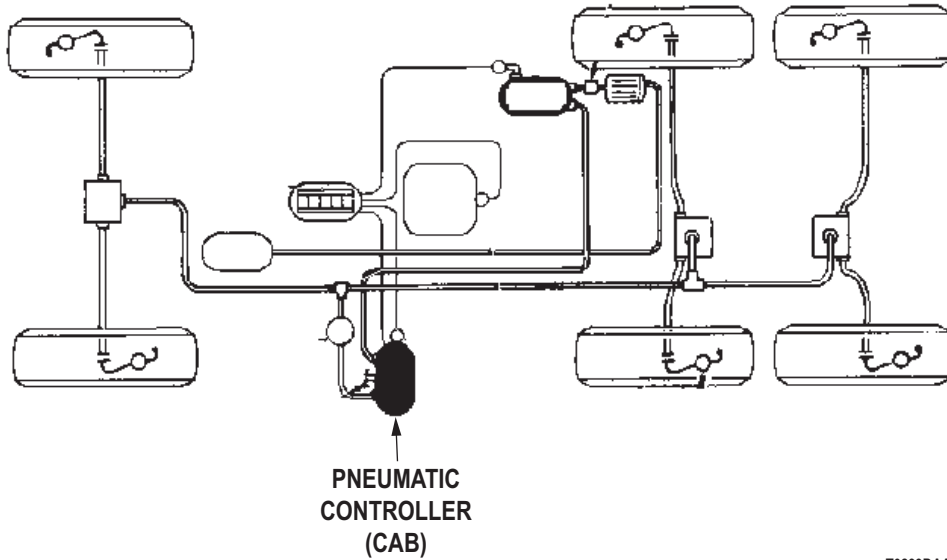

T0899DAA

Figure 7. Pneumatic Controller.

CONDITION/INDICATION

IS THE PNEUMATIC CONTROLLER IN GOOD CONDITION?

DECISION

YES - Go to Step (8).

NO - Replace pneumatic controller (Volume 5, WP 0810). Go to Step (17) to verify problem is solved.

FIVE INDICATOR LIGHTS FLASHING - Continued

STEP

8. DOES CTIS SYSTEM OPERATE CORRECTLY AFTER THE ELECTRICAL LEAD IS PROPERLY CONNECTED TO PRESSURE TRANSDUCER ON WET TANK?
 - a. Turn battery switch to OFF position.
 - b. Refer to point to point schematics.

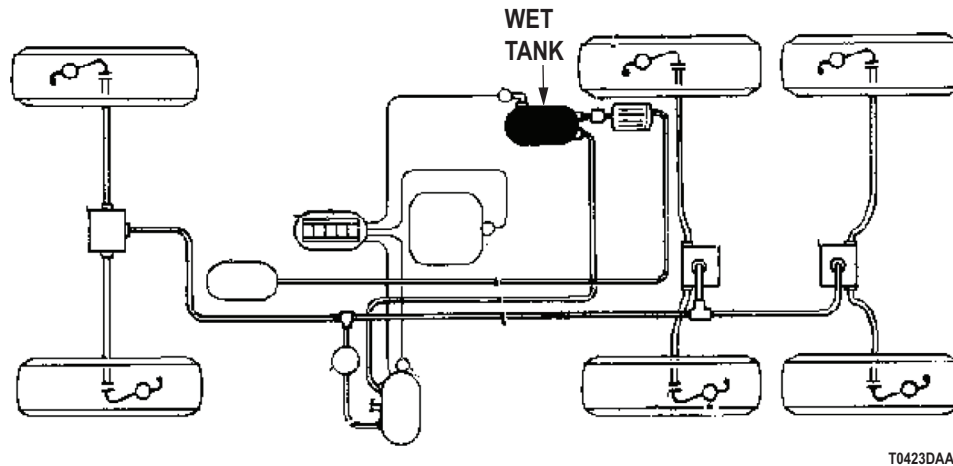

T0423DAA

Figure 8. Wet Tank.

- c. Remove electrical lead from pressure switch at wet tank.
- d. Clean the connectors, then reconnect electrical lead to pressure switch.
- e. Check CTIS operation.

CONDITION/INDICATION

DOES CTIS SYSTEM OPERATE CORRECTLY AFTER THE ELECTRICAL LEAD IS PROPERLY CONNECTED TO PRESSURE TRANSDUCER ON WET TANK?

DECISION

- YES - Go to Step (17) to verify problem is solved.
 NO - Go to Step (9).

FIVE INDICATOR LIGHTS FLASHING - Continued

STEP

9. IS THERE CONTINUITY BETWEEN PRESSURE SWITCH AND CTIS WIRING HARNESS CANNON PLUG AT ECU?

a. Refer to point to point schematics.

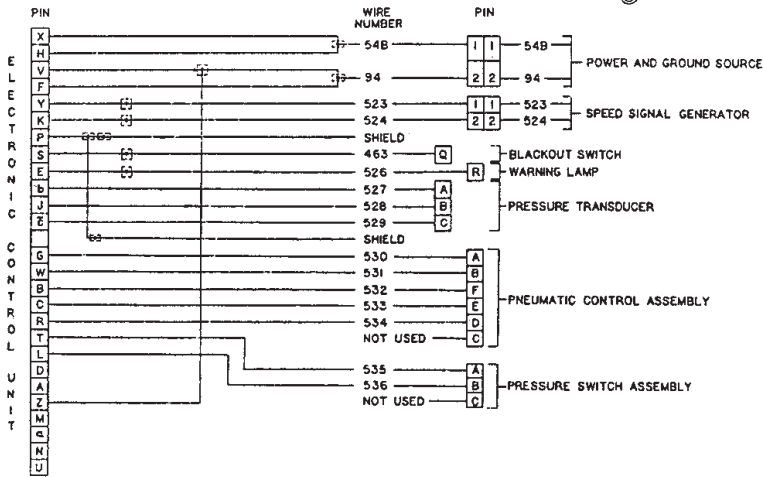
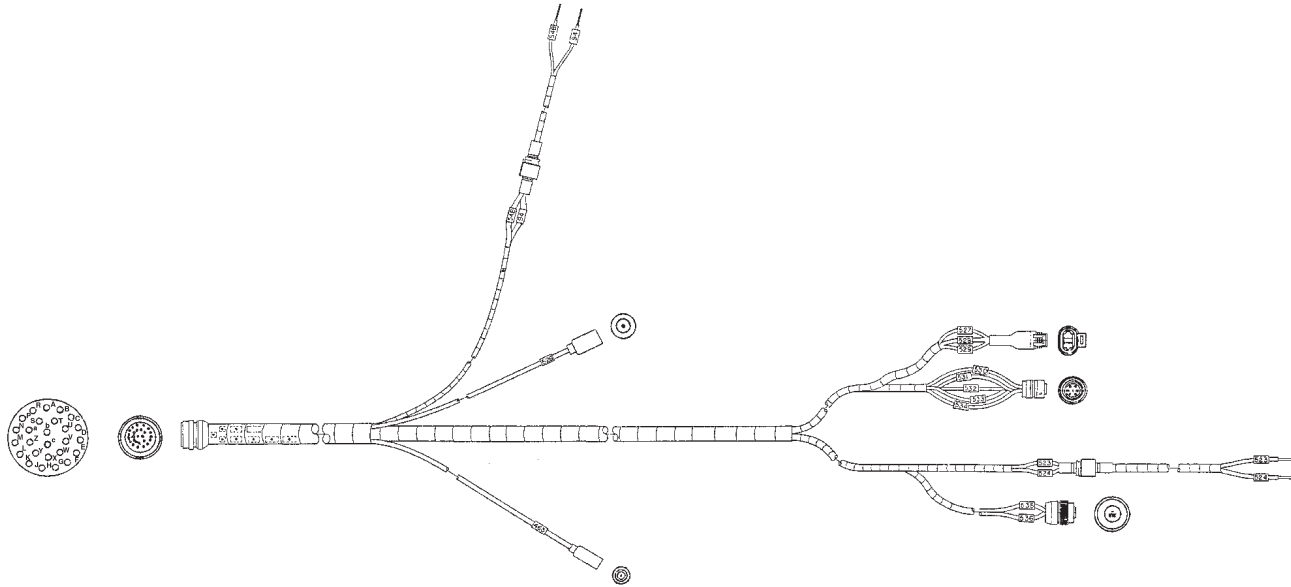

WIRING DIAGRAM

T0432DAA

Figure 9. CTIS Wiring Harness.

- b. Set multimeter to measure resistance.
- c. Connect multimeter red lead to CTIS wiring harness cannon plug.
- d. Connect multimeter black lead to electrical lead at pressure switch.
- e. Meter reading should be less than 200 ohms.

FIVE INDICATOR LIGHTS FLASHING - Continued

CONDITION/INDICATION

IS THERE CONTINUITY BETWEEN PRESSURE SWITCH AND CTIS WIRING HARNESS CANNON PLUG AT ECU?

DECISION

YES - Go to Step (10).

NO - Replace CTIS wiring harness (Volume 2, WP 0322). Go to Step (17) to verify problem is solved.

STEP

10. IS THERE CONTINUITY BETWEEN PRESSURE SWITCH PINS A AND B WHEN AIR SYSTEM IS AT NORMAL OPERATING PRESSURE?
 - a. Refer to point to point schematics.

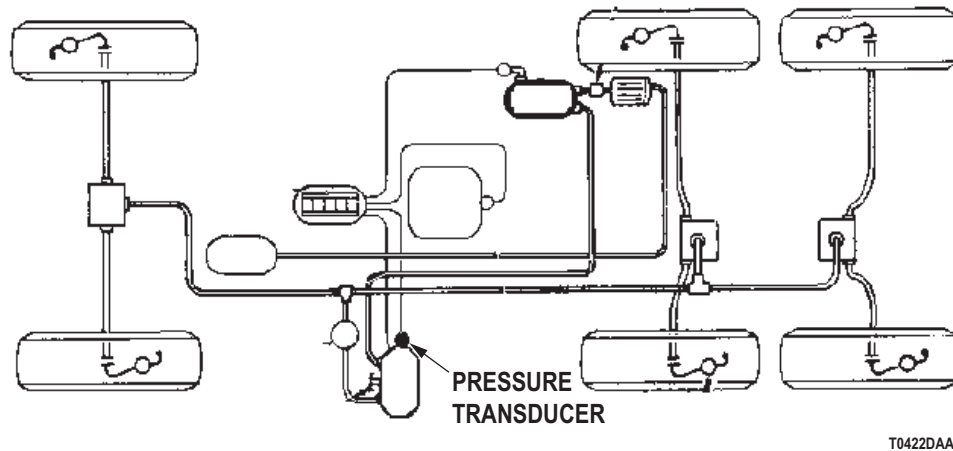

Figure 10. Pressure Transducer.

- b. Connect multimeter red lead to to pressure switch at pin A.
- c. Connect multimeter black lead to pressure switch at pin B.
- d. Use shop air pressure or start and run engine until air pressure reaches 112-120 psi while monitoring the instrument cluster air pressure gauge.
- e. Pressure switch should be closed.
- f. Meter reading should be less than 20 ohms.

CONDITION/INDICATION

IS THERE CONTINUITY BETWEEN PRESSURE SWITCH PINS A AND B WHEN AIR SYSTEM IS AT NORMAL OPERATING PRESSURE?

DECISION

YES - Go to Step (11).

NO - Replace pressure switch (Volume 2, WP 0324). Go to Step (17) to verify problem is solved.

FIVE INDICATOR LIGHTS FLASHING - Continued**STEP**

11. IS THERE NO CONTINUITY BETWEEN PRESSURE SWITCH PINS A AND B WHEN AIR SYSTEM IS BELOW OPERATING PRESSURE?

- a. Refer to point to point schematics.

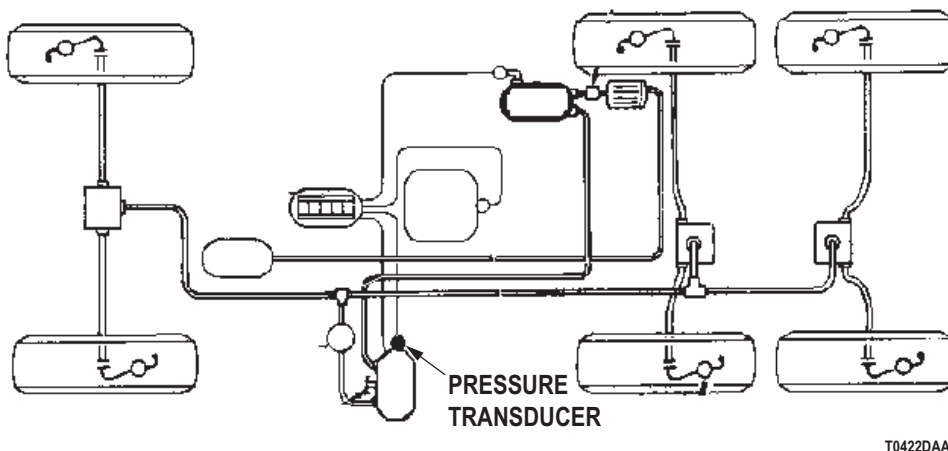

Figure 11. Pressure Transducer.

- b. Connect multimeter red lead to pressure switch at pin A.
 c. Connect multimeter black lead to pressure switch at pin B.
 d. Shut off air supply or engine.
 e. Drain secondary tank until air pressure gauge indicates less than 80 psi..
 f. Pressure switch should open.
 g. Meter reading should be greater than 90 ohms.

CONDITION/INDICATION

IS THERE NO CONTINUITY BETWEEN PRESSURE SWITCH PINS A AND B WHEN AIR SYSTEM IS BELOW OPERATING PRESSURE?

DECISION

YES - Go to Step (12).

NO - Replace pressure switch (Volume 2, WP 0324). Go to Step (17) to verify problem is solved.

FIVE INDICATOR LIGHTS FLASHING - Continued**STEP**

12. IS THE VOLTAGE FROM THE ECU TO THE PRESSURE SWITCH NORMAL?
- a. Start engine and run while monitoring the instrument cluster air pressure gauge.

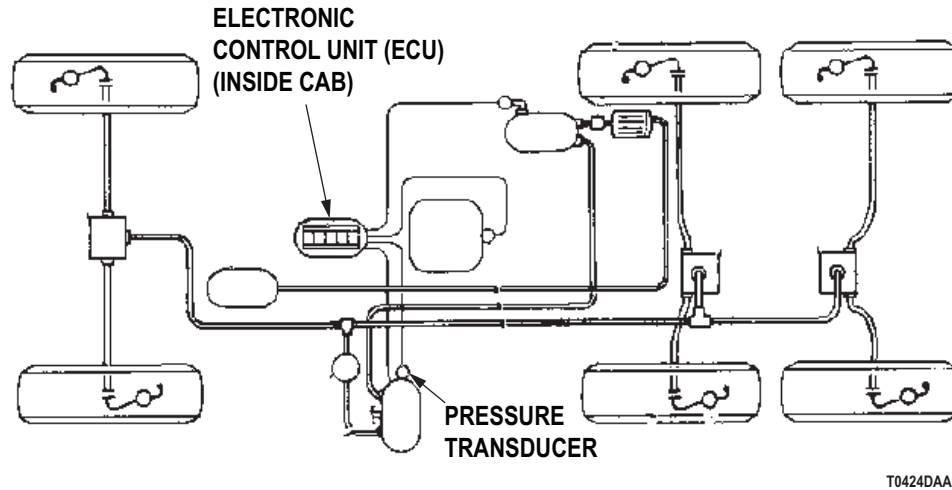

Figure 12. Electronic Control Unit .

- b. Operate until air pressure gauge indicates 112-120 psi. If gauge does not reach 112-120 psi or greater, adjust air governor.
- c. With engine running, drain secondary air tank until air pressure gauge indicates less than 80 psi.
- d. Set multimeter to measure VDC.
- e. Connect CTIS wiring harness cannon plug to ECU.
- f. Place battery switch to ON position.
- g. Connect multimeter red lead to pressure switch connector.
- h. Connect multimeter black lead to a known good ground.
- i. Meter reading should be greater than 18 VDC.

CONDITION/INDICATION

IS THE VOLTAGE FROM THE ECU TO THE PRESSURE SWITCH NORMAL?

DECISION

YES - Go to Step (13).

NO - Replace ECU (Volume 5, WP 0813). Go to Step (17) to verify problem is solved.

FIVE INDICATOR LIGHTS FLASHING - Continued

STEP

13. IS THERE CONTINUITY BETWEEN PRESSURE TRANSDUCER AND ECU CANNON PLUG?

- a. Refer to point to point schematics.
- b. Connect CTIS wiring harness electrical lead to pressure switch.
- c. Check connection of electrical lead at pressure transducer on pneumatic controller. Clean and tighten as needed.

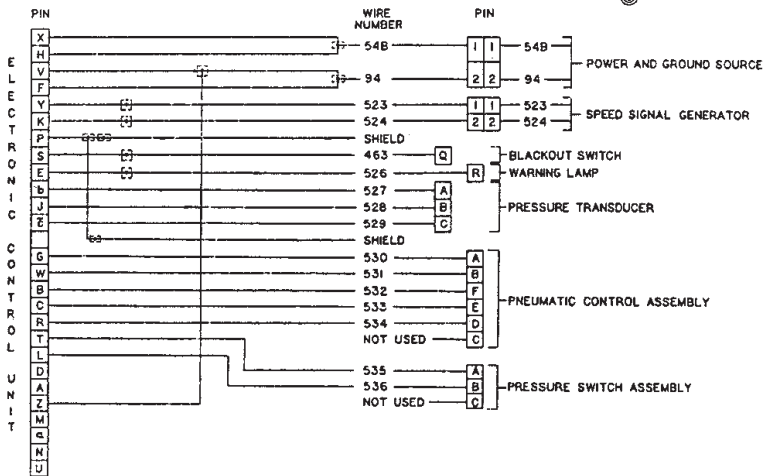
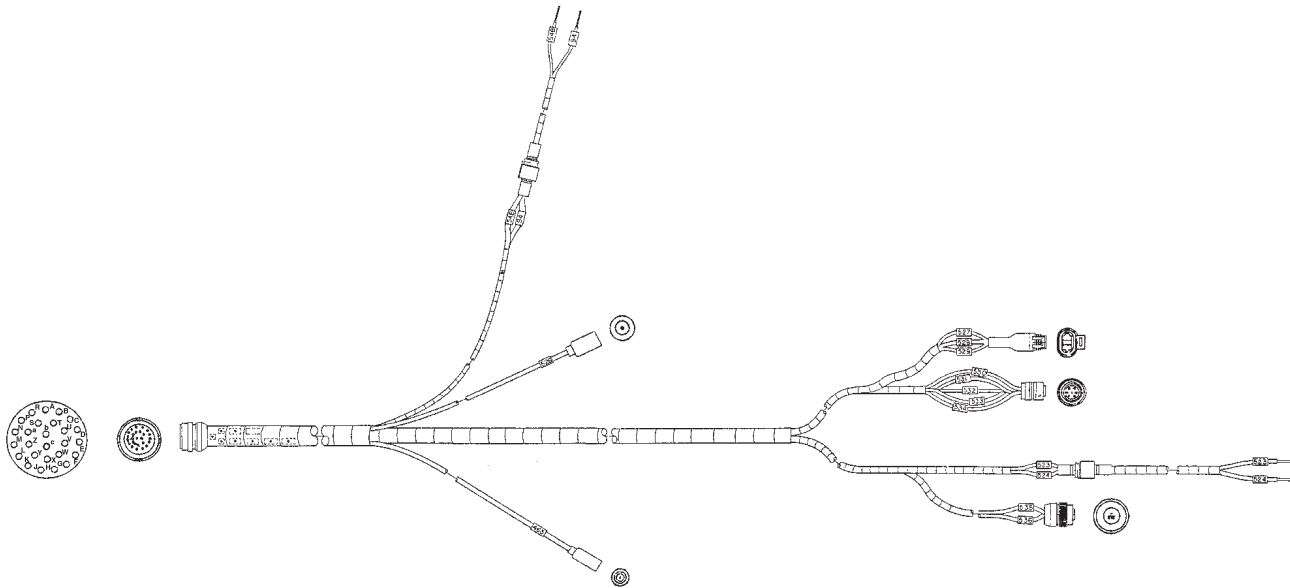

WIRING DIAGRAM

T0432DAA

Figure 13. CTIS Wiring Harness.

CAUTION

Turn battery switch to OFF position before disconnecting or connecting ECU wiring harness. Failure to do so may result in damage to ECU.

- d. Turn battery switch to OFF position.

FIVE INDICATOR LIGHTS FLASHING - Continued

- e. Disconnect CTIS wiring harness cannon plug at ECU.
- f. Disconnect electrical lead at pressure transducer.
- g. Set multimeter to measure resistance.
- h. Connect multimeter red lead to pressure transducer.
- i. Connect multimeter black lead to pressure transducer lead at ECU cannon plug.
- j. Meter reading should be less than 200 ohms.

CONDITION/INDICATION

IS THERE CONTINUITY BETWEEN PRESSURE TRANSDUCER AND ECU CANNON PLUG?

DECISION

YES - Go to Step (14).

NO - Replace CTIS Wiring Harness (Volume 2, WP 0322). Go to Step (17) to verify problem is solved.

FIVE INDICATOR LIGHTS FLASHING - Continued

STEP

14. IS THERE BATTERY VOLTAGE PRESENT AT PINS X AND V ON CTIS WIRING HARNESS CANNON PLUG AT ECU?

- a. Refer to point to point schematics.

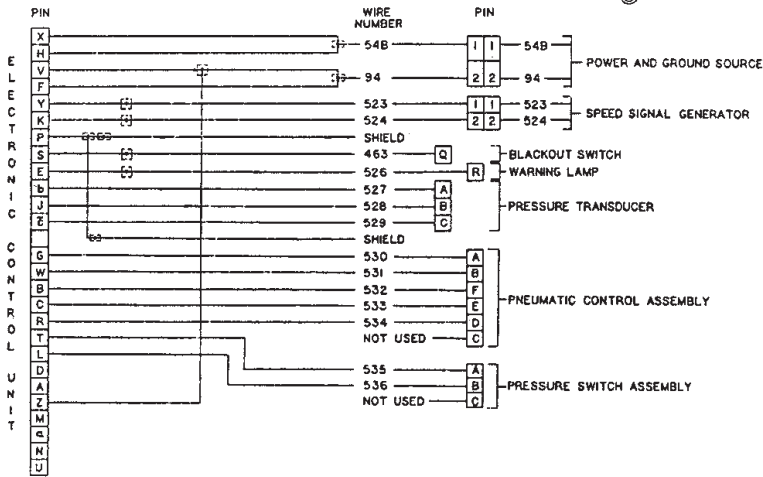
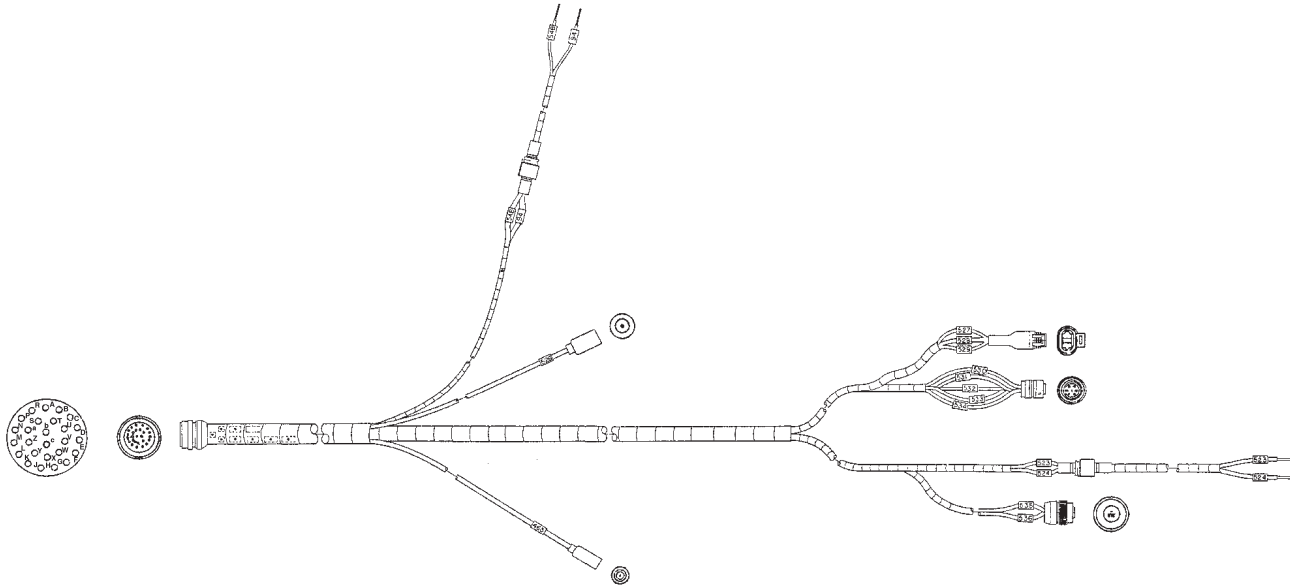

WIRING DIAGRAM

T0432DAA

Figure 14. CTIS Wiring Harness.

CAUTION

Turn battery switch to OFF position before disconnecting or connecting ECU wiring harness. Failure to do so may result in damage to ECU.

- b. Turn battery switch to OFF position.
- c. Disconnect CTIS wiring harness cannon plug at ECU.
- d. Set multimeter to measure VDC.

FIVE INDICATOR LIGHTS FLASHING - Continued

- e. Turn battery switch to ON position.
- f. Connect multimeter red lead to CTIS wiring harness cannon plug pin V.
- g. Connect multimeter black lead to CTIS wiring harness cannon plug pin X.
- h. Meter reading should be between 18 and 26 VDC.

CONDITION/INDICATION

IS THERE BATTERY VOLTAGE PRESENT AT PINS X AND V ON CTIS WIRING HARNESS CANNON PLUG AT ECU?

DECISION

YES - Go to Step (15).

NO - Perform Engine Fails To Crank troubleshooting (WP 0006).

FIVE INDICATOR LIGHTS FLASHING - Continued

STEP

15. IS THERE 4.75 to 5.25 VDC PRESENT AT PRESSURE TRANSDUCER?

- a. Refer to point to point schematics.

CAUTION

Turn battery switch to OFF position before disconnecting or connecting ECU wiring harness. Failure to do so may result in damage to ECU.

- b. Turn battery switch to OFF position.
- c. Connect CTIS wiring harness cannon plug at ECU.

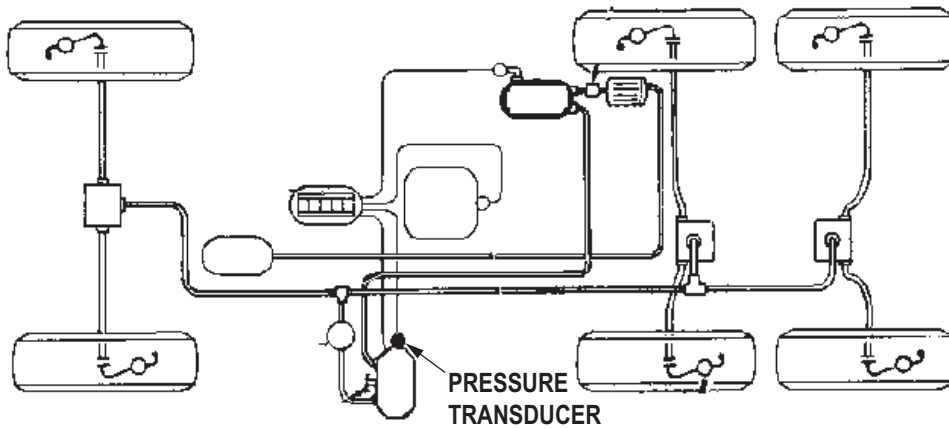

Figure 15. Pressure Transducer.

- d. Disconnect CTIS wiring harness electrical lead from pressure transducer.
- e. Turn battery switch to ON position.
- f. Connect multimeter red lead to wire at pressure transducer.
- g. Connect multimeter black lead to a known good ground.
- h. Meter reading should be between 4.75 and 5.25 VDC.

CONDITION/INDICATION

IS THERE 4.75-5.25 VDC PRESENT AT PRESSURE TRANSDUCER?

DECISION

YES - Replace pressure transducer (Volume 5, WP 0812). Go to Step (17) to verify problem is solved.
 NO - Go to Step (16).

FIVE INDICATOR LIGHTS FLASHING - Continued

STEP

16. IS THE PNEUMATIC CONTROLLER IN GOOD CONDITION?

Listen for clicking noise while changing CTIS mode.

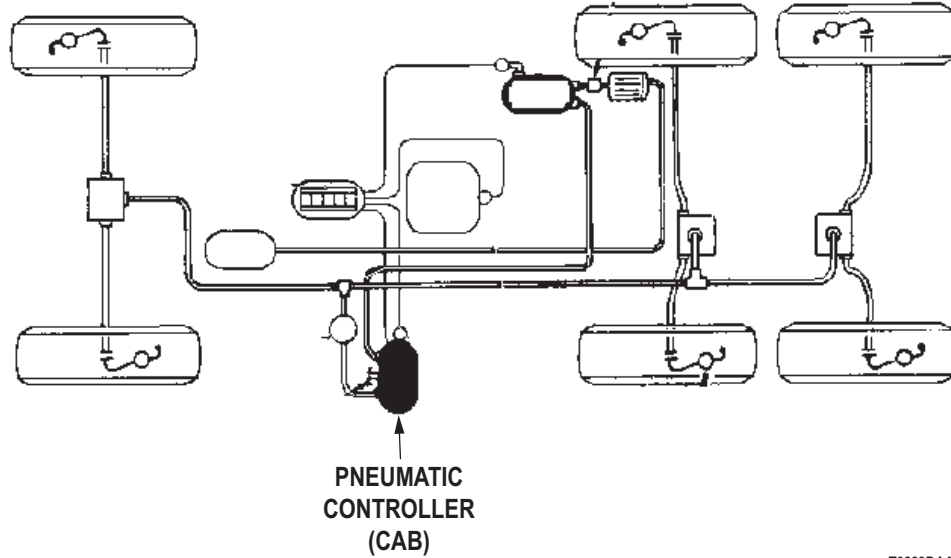

T0899DAA

Figure 16. Pneumatic Controller.

CONDITION/INDICATION

IS THE PNEUMATIC CONTROLLER IN GOOD CONDITION?

DECISION

- YES - Replace electronic control unit (Volume 5, WP 0813) . Go to Step (17) to verify problem is solved.
- NO - Replace pneumatic controller (Volume 5, WP 0810). Go to Step (17) to verify problem is solved.

STEP

17. IS YOUR ORIGINAL PROBLEM STILL PRESENT?

- a. Ensure vehicle is returned to normal operating condition.
- b. Check to see if your original problem still exists.

CONDITION/INDICATION

IS YOUR ORIGINAL PROBLEM STILL PRESENT?

DECISION

- YES - Notify supervisor.
- NO - Problem fixed.

END OF WORK PACKAGE

FIELD MAINTENANCE
SYSTEM REPEATEDLY RESUMES CYCLING 30 SECONDS AFTER MODE LIGHT STOPS FLASHING

INITIAL SETUP:**Tools and Special Tools**

Tool Kit, General Mechanic's: Automotive
(Volume 5, WP 0826, Table 1, Item 56)
Soap Solution
Test Set, Electronic Systems
(Volume 5, WP 0826, Table 1, Item 51)

References (cont.)

TM 9-2320-272-10
Volume 3, WP 0490
Volume 3, WP 0491

Equipment Condition

Vehicle parked and engine shut down.
(TM 9-2320-272-10)

Personnel Required

(2)

References

Point to Point Schematics

TROUBLESHOOTING PROCEDURE**SYSTEM REPEATEDLY RESUMES CYCLING 30 SECONDS AFTER MODE LIGHT STOPS FLASHING****NOTE**

- Conduct these malfunction tests if the system repeatedly resumes cycling 30 seconds after mode light stops flashing. This procedure will check for leaking air lines between wheel valves and wheels. It will also check for a faulty wheel valve.
- The ECU is programmed to check tire pressures 30 seconds after completing a pressure changing sequence. The ECU does this to verify that all wheel valves are properly closed before making pressure checks at fifteen minute intervals. If the ECU repeatedly checks pressure 30 seconds after a mode light stops flashing, it is indicative of one or more tires losing air.

SYSTEM REPEATEDLY RESUMES CYCLING 30 SECONDS AFTER MODE LIGHT STOPS FLASHING - Continued

STEP

1. DO AIR LINES BETWEEN WHEEL VALVE AND WHEEL RIM HAVE CRACKS OR OTHER DAMAGE?
 - a. Measure and record pressure of each tire (TM 9-2320-272-10).

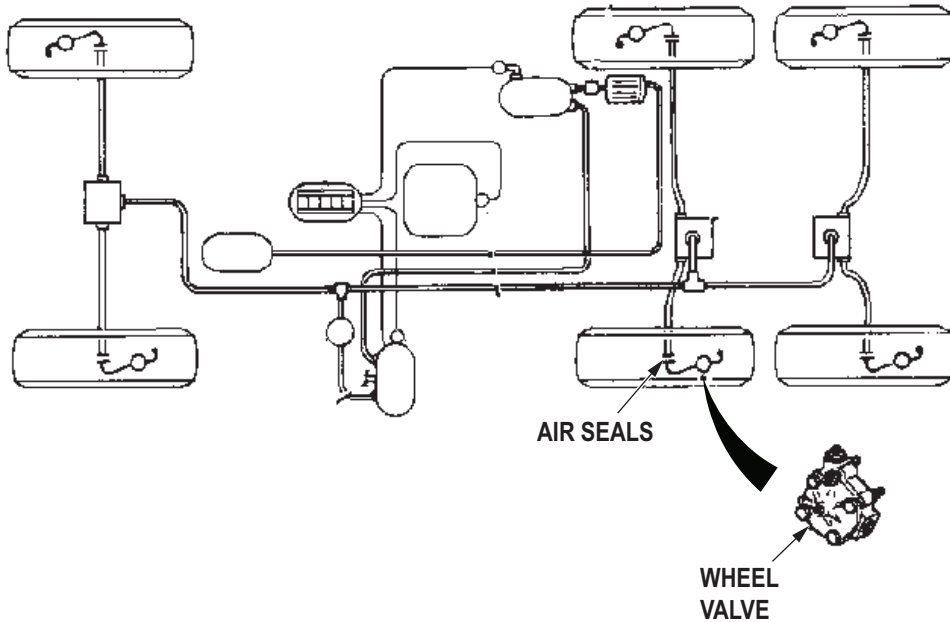

T0897DAA

Figure 1. Wheel Valve.

- b. Refer to point to point schematics.

WARNING

Air system components are subject to high pressure. Always relieve pressure before loosening or removing air system components. Failure to comply may result in injury or death to personnel.

- c. For all tires significantly outside pressure limits, inspect front wheel air lines and inspect rear wheel air lines between wheel valve and wheel rim for cracks and damage.

CONDITION/INDICATION

DO AIR LINES BETWEEN WHEEL VALVE AND WHEEL RIM HAVE CRACKS OR OTHER DAMAGE?

DECISION

- YES - Front air lines damaged M939A2. Replace damaged air line (Volume 3, WP 0490). Go to Step (4) to verify problem is solved.
- YES - Rear air lines are damaged M939A2. Replace damaged air line (Volume 3, WP 0491). Go to Step (4) to verify problem is solved.
- NO - Go to Step (2).

SYSTEM REPEATEDLY RESUMES CYCLING 30 SECONDS AFTER MODE LIGHT STOPS FLASHING - Continued

STEP

- 2. DO AIR LINES BETWEEN WHEEL VALVE AND WHEEL RIM HAVE ANY AIR LEAKS?
 - a. Refer to point to point schematics.

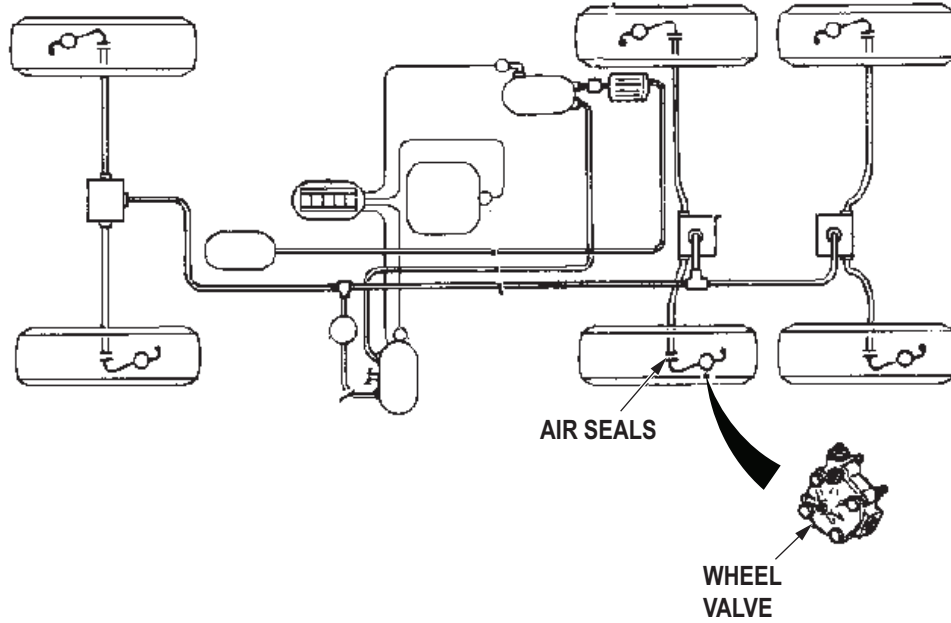

T0897DAA

Figure 2. Wheel Valve.

- b. For all tires previously found to be significantly outside pressure limits, use soapy water at air line wheel valve and wheel rim connections to check for leaks.

CONDITION/INDICATION

DO AIR LINES BETWEEN WHEEL VALVE AND WHEEL RIM HAVE ANY AIR LEAKS?

DECISION

- YES - Front air lines leak M939A2. Replace damaged air line (Volume 3, WP 0490). Go to Step (4) to verify problem is solved.
- YES - Rear air lines leak M939A2. Replace damaged air line (Volume 3, WP 0491). Go to Step (4) to verify problem is solved.
- NO - Go to Step (3).

**SYSTEM REPEATEDLY RESUMES CYCLING 30 SECONDS AFTER MODE LIGHT STOPS FLASHING -
Continued**

STEP

3. DOES WHEEL VALVE LEAK AIR?

- a. Refer to point to point schematics.

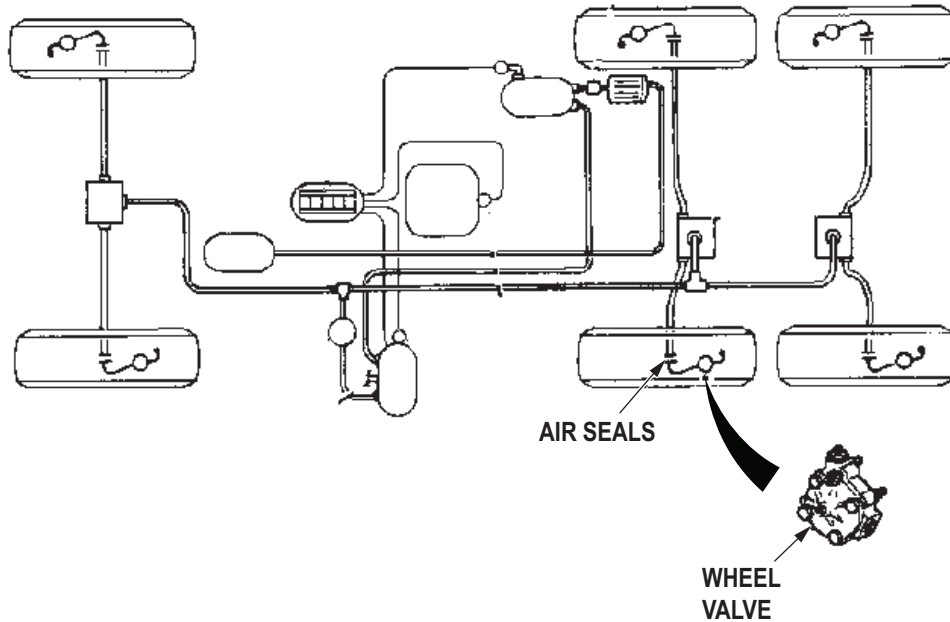

T0897DAA

Figure 3. Wheel Valve.

WARNING

Air system components are subject to high pressure. Always relieve pressure before loosening or removing air system components. Failure to comply may result in injury or death to personnel.

NOTE

To determine a wheel valve air leak, with wheel valve still connected to tire, check for air leak at quick release valves. Determine which valve is leaking, by disconnecting air line at quick release valve to either feel or listen for air escaping.

- b. Check for air leak at the quick release valves.

**SYSTEM REPEATEDLY RESUMES CYCLING 30 SECONDS AFTER MODE LIGHT STOPS FLASHING -
Continued****CONDITION/INDICATION**

DOES WHEEL VALVE LEAK AIR?

DECISION

YES - Front wheel valve leaks M939A2. Replace wheel valve (Volume 3, WP 0490). Go to Step (4) to verify problem is solved.

YES - Rear wheel valve leaks M939A2. Replace wheel valve (Volume 3, WP 0491). Go to Step (4) to verify problem is solved.

NO - Go to Step (4) to verify problem is solved.

STEP

4. IS YOUR ORIGINAL PROBLEM STILL PRESENT?
 - a. Ensure vehicle is returned to normal operating condition.
 - b. Check to see if your original problem still exists.

CONDITION/INDICATION

IS YOUR ORIGINAL PROBLEM STILL PRESENT?

DECISION

YES - Notify supervisor.

NO - Problem fixed.

END OF WORK PACKAGE

FIELD MAINTENANCE
SYSTEM FAILS TO DEFLATE, PARTIALLY DEFLATES, OR TIRE PRESSURES ARE IMBALANCED

INITIAL SETUP:**Tools and Special Tools**

Tool Kit, General Mechanic's: Automotive
(Volume 5, WP 0826, Table 1, Item 56)
Goggles, Industrial
(Volume 5, WP 0826, Table 1, Item 20)
Soap Solution
Test Set, Electronic Systems
(Volume 5, WP 0826, Table 1, Item 51)

References (cont.)

Volume 3, WP 0481
Volume 3, WP 0482
Volume 3, WP 0487
Volume 3, WP 0490
Volume 3, WP 0491
Volume 5, WP 0805
Volume 5, WP 0806
Volume 5, WP 0809
Volume 5, WP 0810

Personnel Required

(2)

References

Point to Point Schematics

Equipment Condition

Vehicle parked and engine shut down.
(TM 9-2320-272-10)

TROUBLESHOOTING PROCEDURE
SYSTEM FAILS TO DEFLATE, PARTIALLY DEFLATES, OR TIRE PRESSURES ARE IMBALANCED**NOTE**

- Conduct these malfunction tests if the system fails to deflate, partially deflates, or tire pressures are imbalanced. This procedure will check for excessive water in tire and faulty relief valve on pneumatic controller, quick release valves, pneumatic controller, air lines, hub air seals, wheel valve, and wheel valve filter.
- During deflation, all tires respond independently. Generally, failure of the entire system to deflate indicates a control problem. Failure of an individual tire to deflate indicates a problem at the wheel.

SYSTEM FAILS TO DEFLATE, PARTIALLY DEFLATES, OR TIRE PRESSURES ARE IMBALANCED - Continued

STEP

1. WHAT IS THE CONDITION OF THE PNEUMATIC CONTROLLER RELIEF VALVE POPPET?
 - a. Refer to point to point schematics.

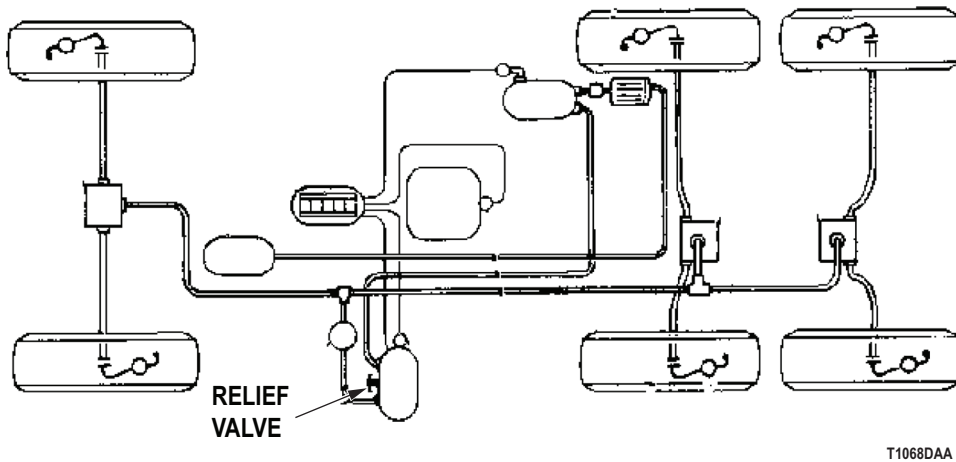

Figure 1. Relief Valve.

- b. Inspect relief valve poppet on pneumatic controller.

CONDITION/INDICATION

WHAT IS THE CONDITION OF THE PNEUMATIC CONTROLLER RELIEF VALVE POPPET?

DECISION

YES - Poppet in. Go to Step (2).

NO - Poppet out. Replace relief valve (Volume 5, WP 0810). Go to Step (11) to verify problem is solved.

SYSTEM FAILS TO DEFLATE, PARTIALLY DEFLATES, OR TIRE PRESSURES ARE IMBALANCED - Continued

STEP

2. ARE THERE ANY CLOGGED QUICK RELEASE VALVES?

- a. Refer to point to point schematics.

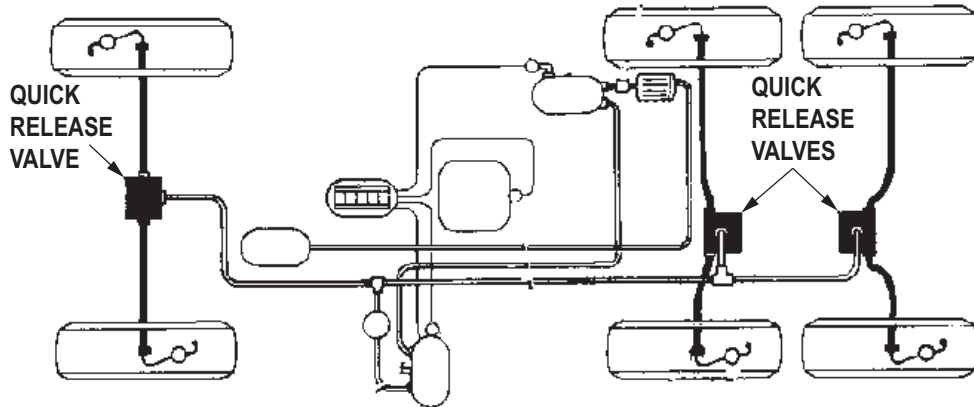

T0417DAA

Figure 2. Quick Release Valves.

WARNING

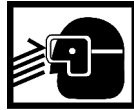

- Release all air pressure before loosening or removing air system component(s). Failure to comply may result in injury or death to personnel.
- Eyeshields must be worn when releasing compressed air. Failure to comply may result in injury or death to personnel.

- b. Check quick release valves for obstructions.

CONDITION/INDICATION

ARE THERE ANY CLOGGED QUICK RELEASE VALVES?

DECISION

- YES - Clear valves (Volume 5, WP 0809). Go to Step (11) to verify problem is solved.
- NO - Go to Step (3).

SYSTEM FAILS TO DEFLATE, PARTIALLY DEFLATES, OR TIRE PRESSURES ARE IMBALANCED - Continued

STEP

3. ARE THERE AIR LEAKS FROM PNEUMATIC CONTROLLER?

- a. Set CTIS switch to HWY and run engine at 1000 rpm for three to five minutes to build air supply to normal operating pressure.
- b. Stop engine.
- c. Turn battery switch to OFF position.
- d. Refer to point to point schematics.

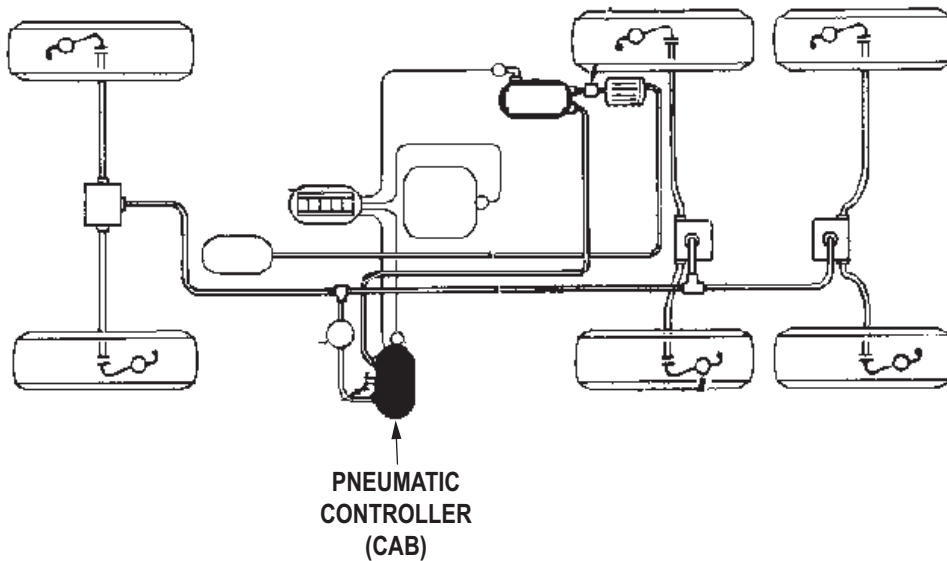

Figure 3. Pneumatic Controller.

- e. Check for air leaks from pneumatic controller.
- f. Use soapy water at connectors to check for leaks.

CONDITION/INDICATION

ARE THERE AIR LEAKS FROM PNEUMATIC CONTROLLER?

DECISION

YES - Repair or replace pneumatic controller (Volume 5, WP 0810). Go to Step (11) to verify problem is solved.
NO - Go to Step (4).

SYSTEM FAILS TO DEFLATE, PARTIALLY DEFLATES, OR TIRE PRESSURES ARE IMBALANCED - Continued

STEP

4. DO AIR LINES BETWEEN PNEUMATIC CONTROLLER, QUICK RELEASE VALVES, AND WHEELS HAVE CRACKS OR OTHER DAMAGE?
 - a. Refer to point to point schematics.

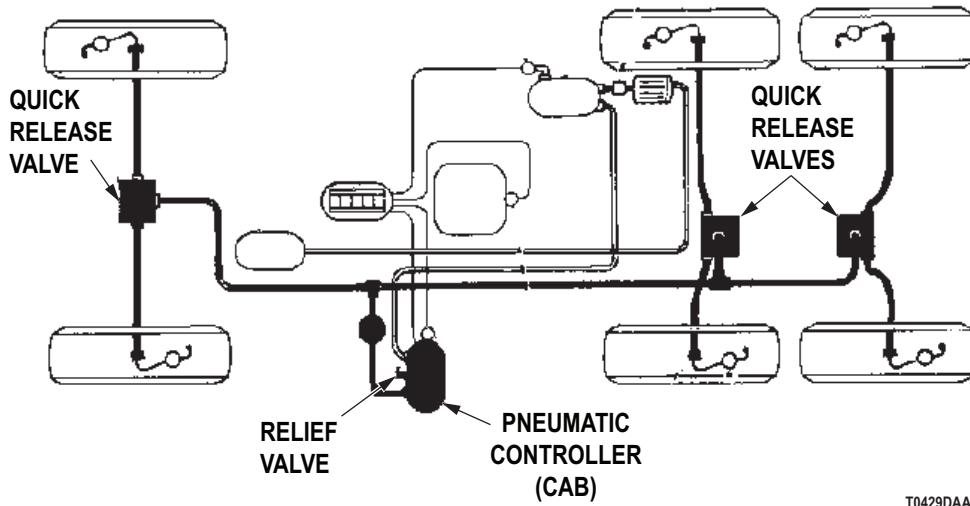

Figure 4. Air Lines.

WARNING

Air system components are subject to high pressure. Always relieve pressure before loosening or removing air system components. Failure to comply may result in injury or death to personnel.

- b. Inspect air lines between quick release valves and pneumatic controller for cracks and damage.

CONDITION/INDICATION

DO AIR LINES BETWEEN PNEUMATIC CONTROLLER, QUICK RELEASE VALVES, AND WHEELS HAVE CRACKS OR OTHER DAMAGE?

DECISION

YES - Replace damaged air lines (Volume 5, WP 0805). Go to Step (11) to verify problem is solved.
 NO - Go to Step (5).

**SYSTEM FAILS TO DEFLATE, PARTIALLY DEFLATES, OR TIRE PRESSURES ARE IMBALANCED -
Continued**

STEP

5. DO AIR LINES BETWEEN PNEUMATIC CONTROLLER, QUICK RELEASE VALVES, AND WHEELS HAVE ANY AIR LEAKS?
 - a. Refer to point to point schematics.

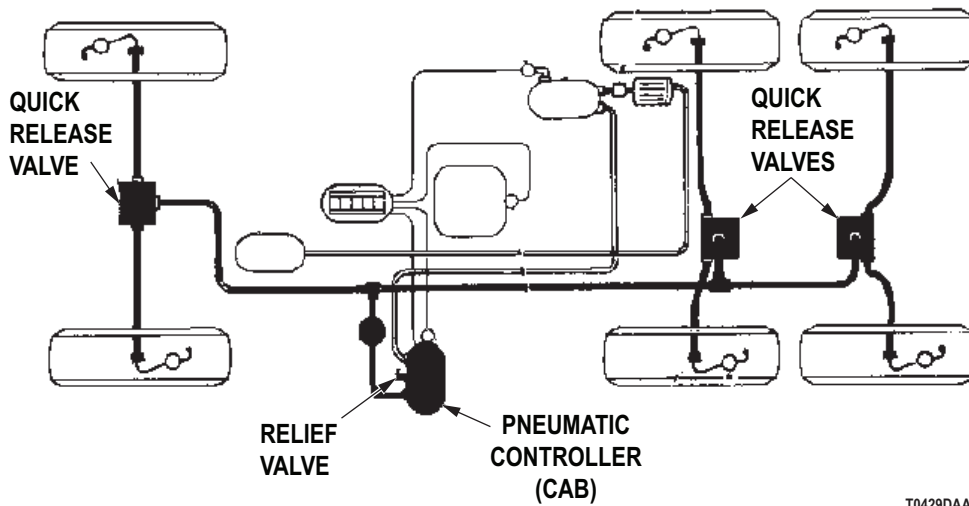

T0429DAA

Figure 5. Air Lines.

- b. Use soapy water at connections to check for air leaks.

CONDITION/INDICATION

DO AIR LINES BETWEEN PNEUMATIC CONTROLLER, QUICK RELEASE VALVES, AND WHEELS HAVE ANY AIR LEAKS?

DECISION

YES - Tighten loose tubing connections (Volume 5, WP 0805). Go to Step (11) to verify problem is solved.
NO - Go to Step (6).

SYSTEM FAILS TO DEFLATE, PARTIALLY DEFLATES, OR TIRE PRESSURES ARE IMBALANCED - Continued

STEP

6. ARE AIR LINES BETWEEN PNEUMATIC CONTROLLER, QUICK RELEASE VALVES, AND WHEELS RESTRICTED?
 - a. Refer to point to point schematics.

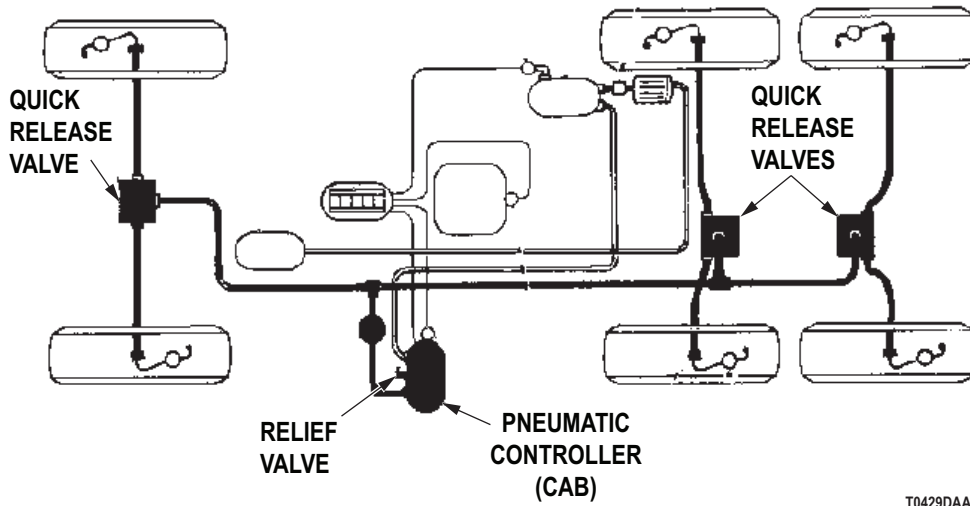
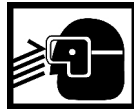

Figure 6. Air Lines.

WARNING



- Release all air pressure before loosening or removing air system component(s). Failure to comply may result in injury or death to personnel.
- Eyeshields must be worn when releasing compressed air. Failure to comply may result in injury or death to personnel.

- b. Disconnect air line at both ends.
- c. Check air line for restrictions.

CONDITION/INDICATION

ARE AIR LINES BETWEEN PNEUMATIC CONTROLLER, QUICK RELEASE VALVES, AND WHEELS RESTRICTED?

DECISION

YES - Clear restriction, then reconnect air line (Volume 5, WP 0805). Go to Step (11) to verify problem is solved.
 NO - Go to Step (7).

SYSTEM FAILS TO DEFLATE, PARTIALLY DEFLATES, OR TIRE PRESSURES ARE IMBALANCED - Continued

STEP

7. DO HUB AIR SEALS LEAK?

- a. Refer to point to point schematics.

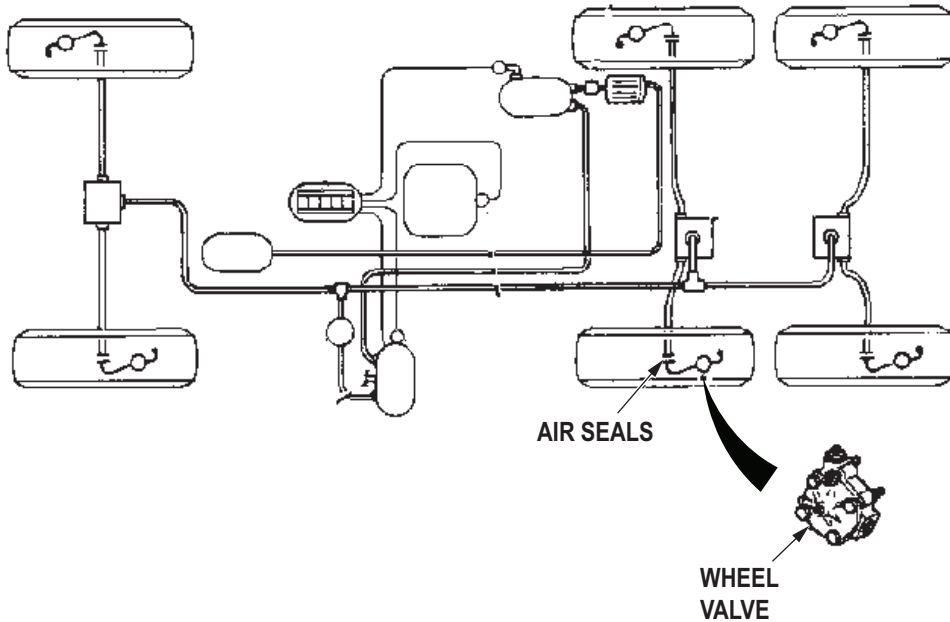

T0898DAA

Figure 7. Hub Air Seals.

- b. Perform leak test (Volume 3, WP 0487) on hub air seals.

CONDITION/INDICATION

DO HUB AIR SEALS LEAK?

DECISION

YES - Front air seals leak. Replace faulty seals (Volume 3, WP 0481). Go to Step (11) to verify problem is solved.

YES - Rear air seals leak. Replace faulty seals (Volume 3, WP 0482). Go to Step (11) to verify problem is solved.

NO - Go to Step (8).

SYSTEM FAILS TO DEFLATE, PARTIALLY DEFLATES, OR TIRE PRESSURES ARE IMBALANCED - Continued

STEP

8. IS THERE AUDIBLE AIR FLOW FROM RELIEF VALVE ON PNEUMATIC CONTROLLER DURING DEFLATION?
- a. Refer to point to point schematics.

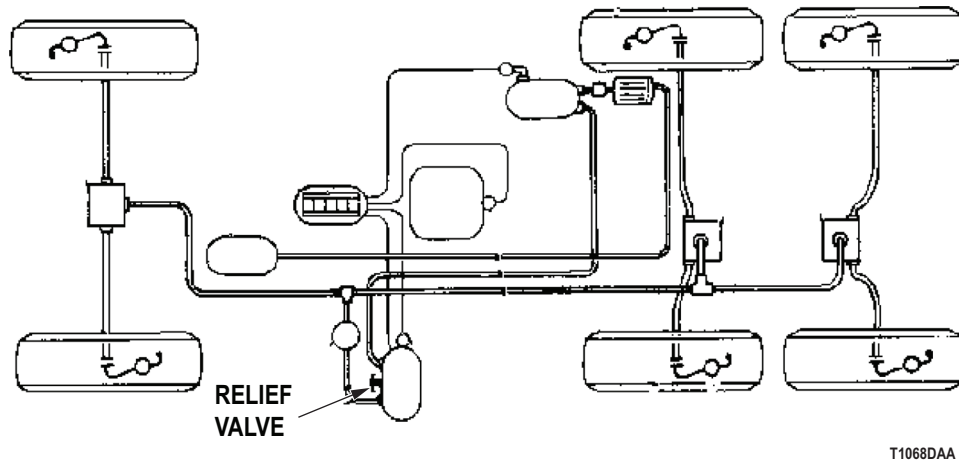

Figure 8. Relief Valve

- b. If air pressure is low, run engine at 1000 rpm for three to five minutes to build air supply to normal operating pressure.
- c. Stop engine.
- d. With the battery switch in the ON position, select a mode that will cause deflation.
- e. Check for continuous and audible air flow from relief valve on pneumatic controller during deflation.

CONDITION/INDICATION

IS THERE AUDIBLE AIR FLOW FROM RELIEF VALVE ON PNEUMATIC CONTROLLER DURING DEFLATION?

DECISION

YES - Go to Step (9).

NO - Replace faulty relief safety valve (Volume 5, WP 0810). Go to Step (11) to verify problem is solved.

SYSTEM FAILS TO DEFLATE, PARTIALLY DEFLATES, OR TIRE PRESSURES ARE IMBALANCED - Continued**STEP**

9. DOES AIR FLOW STEADILY FROM TIRE DURING DEFLATION?
 - a. Refer to point to point schematics.

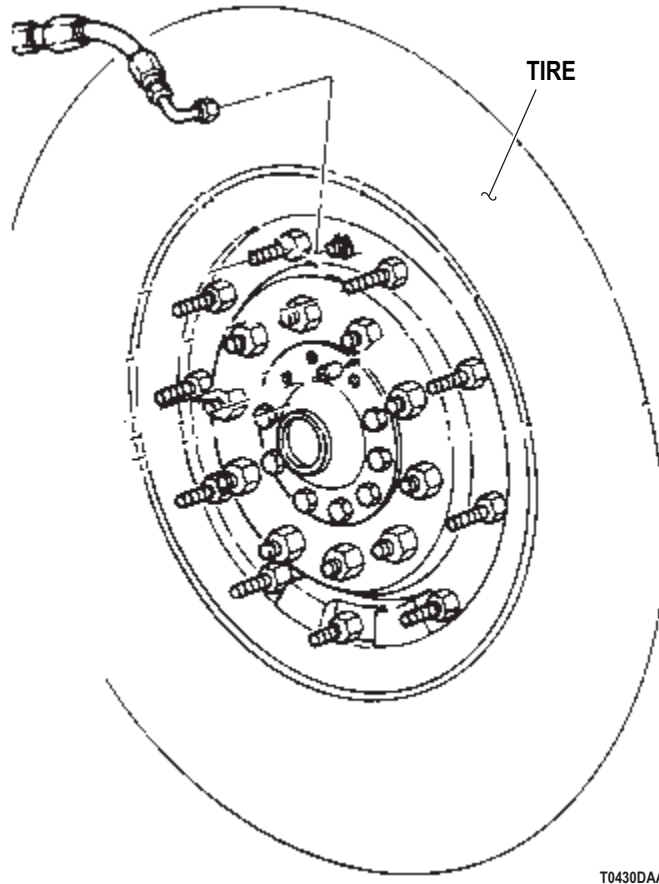

Figure 9. Tire

WARNING

Air system components are subject to high pressure. Always relieve pressure before loosening or removing air system components. Failure to comply may result in injury or death to personnel.

CAUTION

Ensure that external air source is as clean and dry as air supplied by vehicle. If in doubt, use the vehicle's air supply. Contamination may cause damage to CTIS.

NOTE

Varying or intermittent air flow identifies a tire as having collected sufficient water to cause icing of the air passage, even at temperatures above freezing.

SYSTEM FAILS TO DEFLATE, PARTIALLY DEFLATES, OR TIRE PRESSURES ARE IMBALANCED - Continued

- b. Identify any tire that does not deflate properly.
- c. Manually inflate tires identified in the previous step to 80 psi (552 kPa).
- d. For each tire inflated in the previous step, disconnect hose assembly from wheel valve and note consistency of air escaping from wheel.
- e. Repeatedly fill tire with dry air and deflate until air flow from hose connected to wheel is steady.

CONDITION/INDICATION

DOES AIR FLOW STEADILY FROM TIRE DURING DEFLATION?

DECISION

YES - Go to Step (11) to verify problem is solved.

NO - Go to Step (10).

**SYSTEM FAILS TO DEFLATE, PARTIALLY DEFLATES, OR TIRE PRESSURES ARE IMBALANCED -
Continued**

STEP

10. IS WHEEL VALVE FILTER OBSTRUCTED?

- a. Remove filter from wheel valve and inspect.

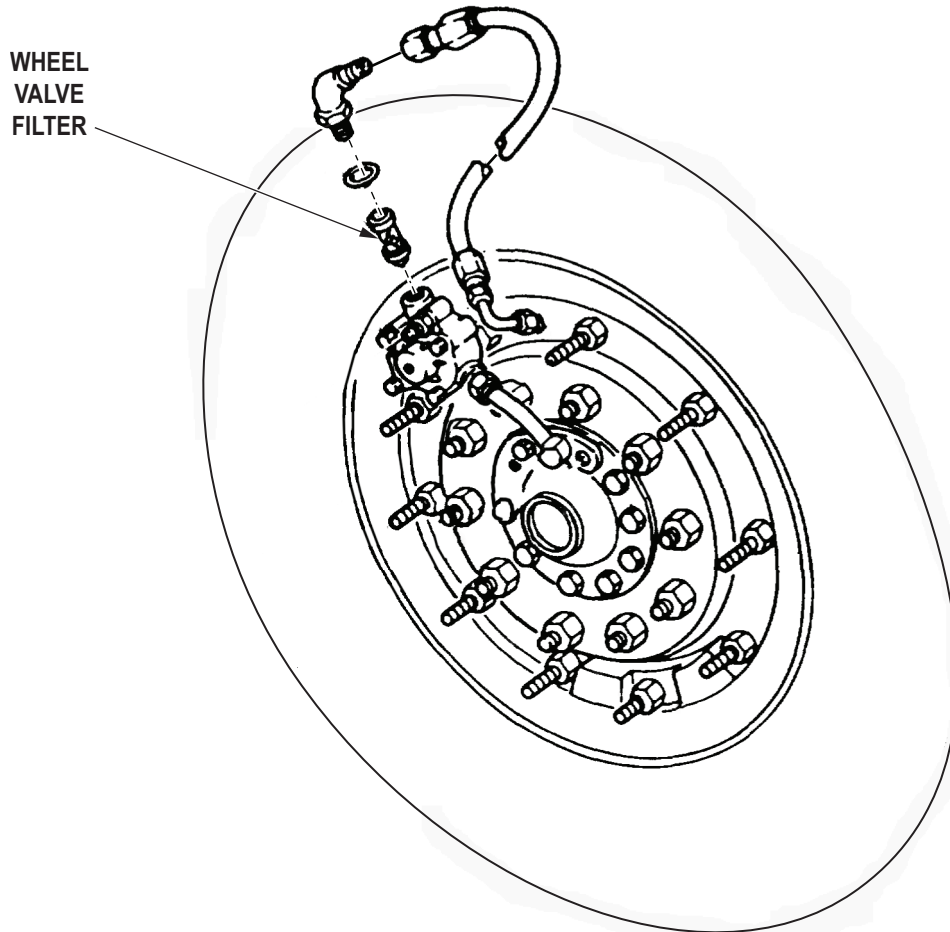

T1110DAA

Figure 10. Wheel Valve Filter.

- b. Connect hose assembly to wheel valve.

**SYSTEM FAILS TO DEFLATE, PARTIALLY DEFLATES, OR TIRE PRESSURES ARE IMBALANCED -
Continued**

CONDITION/INDICATION

IS WHEEL VALVE FILTER OBSTRUCTED?

DECISION

YES - Replace wheel valve filter (Volume 3, WP 0486). Go to Step (11) to verify problem is solved.

NO - Perform wheel valve maintenance front (Volume 3, WP 0490), rear (Volume 3, WP 0491). Go to Step (11) to verify problem is solved.

STEP

11. IS YOUR ORIGINAL PROBLEM STILL PRESENT?

- a. Ensure vehicle is returned to normal operating condition.
- b. Check to see if your original problem still exists.

CONDITION/INDICATION

IS YOUR ORIGINAL PROBLEM STILL PRESENT?

DECISION

YES - Notify supervisor.

NO - Problem fixed.

END OF WORK PACKAGE

FIELD MAINTENANCE
CONTROL PANEL LIGHTS WORK, SYSTEM FAILS TO INFLATE OR DEFLATE

INITIAL SETUP:**Tools and Special Tools**

Tool Kit, General Mechanic's: Automotive
(Volume 5, WP 0826, Table 1, Item 56)
Goggles, Industrial
(Volume 5, WP 0826, Table 1, Item 20)
Multimeter
(Volume 5, WP 0826, Table 1, Item 34)
Soap Solution
Test Set, Electronic Systems
(Volume 5, WP 0826, Table 1, Item 51)

References (cont.)

WP 0128
Volume 2, WP 0322
Volume 2, WP 0324
Volume 5, WP 0805
Volume 5, WP 0810

Equipment Condition

Vehicle parked and engine shut down.
(TM 9-2320-272-10)

Personnel Required

(2)

References

Point to Point Schematics

TROUBLESHOOTING PROCEDURE**CONTROL PANEL LIGHTS WORK, SYSTEM FAILS TO INFLATE OR DEFLATE****NOTE**

Conduct these malfunction tests if control panel lights work, but the system fails to inflate or deflate. This procedure will check for a problem with air lines between pneumatic controller and wet tank. It will also check for a faulty air supply from the vehicle air compressor, CTIS wiring harness, pneumatic controller, electrical lead at wet tank pressure switch, and pressure switch.

CONTROL PANEL LIGHTS WORK, SYSTEM FAILS TO INFLATE OR DEFLATE - Continued

STEP

1. DO AIR LINES BETWEEN WET TANK AND PNEUMATIC CONTROLLER HAVE CRACKS OR OTHER DAMAGE?
 - a. Refer to point to point schematics.

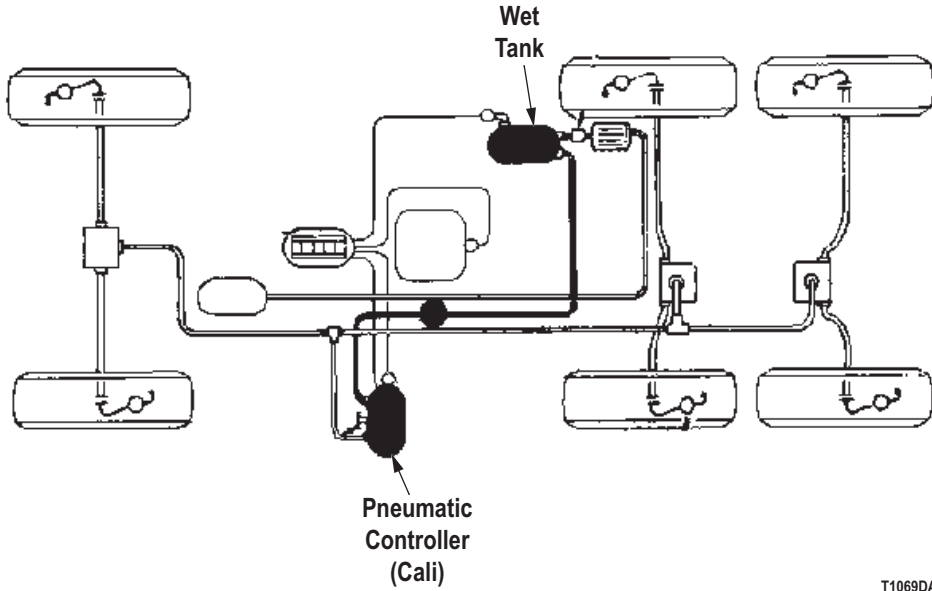

T1069DAA

Figure 1. Air Lines.

WARNING

Air system components are subject to high pressure. Always relieve pressure before loosening or removing air system components. Failure to comply may result in injury or death to personnel.

- b. Inspect air lines between wet tank and pneumatic controller for cracks and damage.

CONDITION/INDICATION

DO AIR LINES BETWEEN WET TANK AND PNEUMATIC CONTROLLER HAVE CRACKS OR OTHER DAMAGE?

DECISION

- YES - Replace damaged air lines (Volume 5, WP 0805). Go to Step (11) to verify problem is solved.
- NO - Go to Step (2).

CONTROL PANEL LIGHTS WORK, SYSTEM FAILS TO INFLATE OR DEFLATE - Continued**STEP**

2. DO AIR LINES BETWEEN WET TANK AND PNEUMATIC CONTROLLER HAVE ANY AIR LEAKS?
 - a. Refer to point to point schematics.

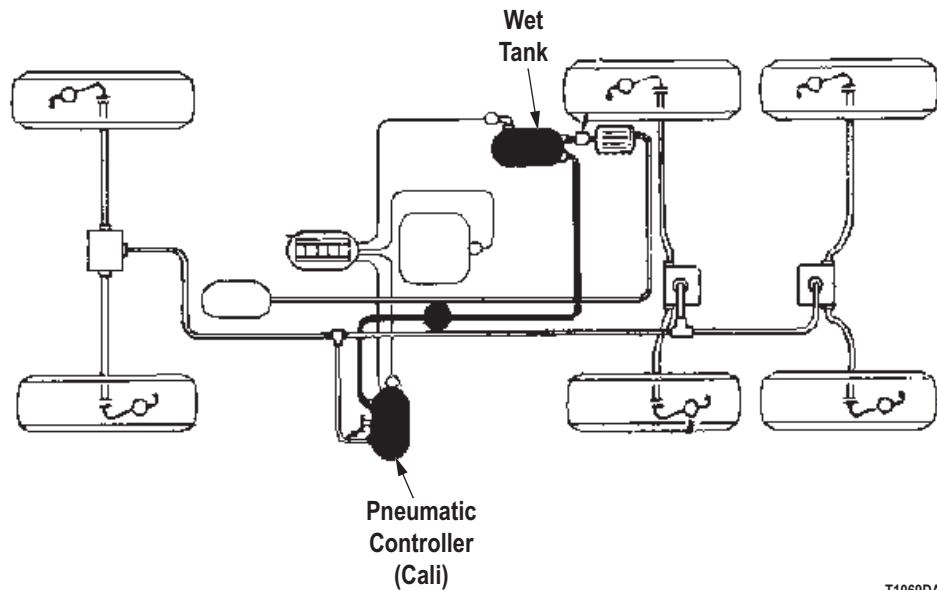

T1069DAA

Figure 2. Air Lines.

- b. Use soapy water at connections to check for air leaks.

CONDITION/INDICATION

DO AIR LINES BETWEEN WET TANK AND PNEUMATIC CONTROLLER HAVE ANY AIR LEAKS?

DECISION

YES - Replace damaged air lines (Volume 5, WP 0805). Go to Step (11) to verify problem is solved.
 NO - Go to Step (3).

CONTROL PANEL LIGHTS WORK, SYSTEM FAILS TO INFLATE OR DEFLATE - Continued

STEP

3. ARE AIR LINES BETWEEN WET TANK AND PNEUMATIC CONTROLLER RESTRICTED?
 - a. Refer to point to point schematics.

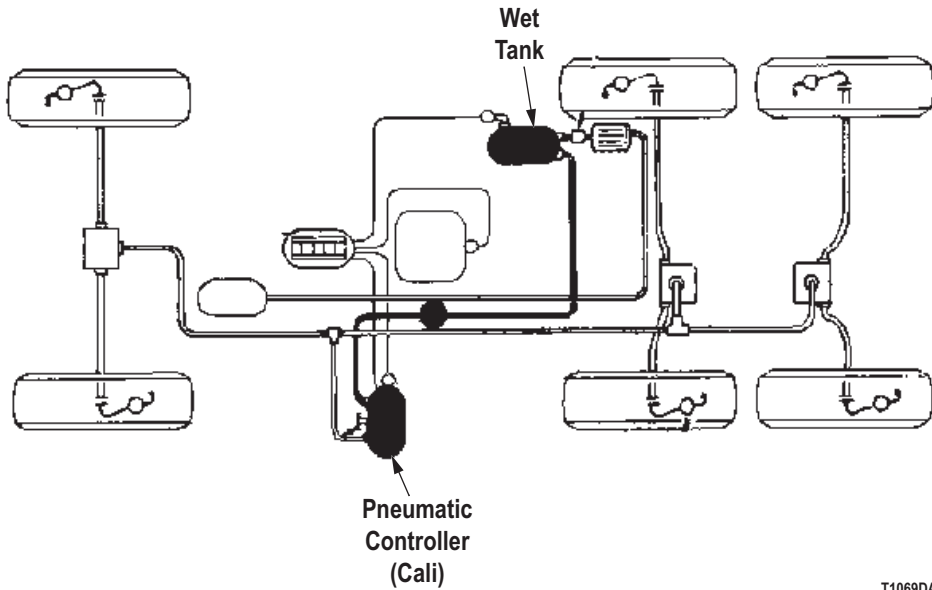

T1069DAA

Figure 3. Air Lines.

WARNING

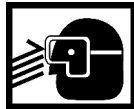

- Release all air pressure before loosening or removing air system component(s). Failure to comply may result in injury or death to personnel.
- Eyeshields must be worn when releasing compressed air. Failure to comply may result in injury or death to personnel.

- b. Disconnect air line at both ends.
- c. Check air line for restrictions.

CONDITION/INDICATION

ARE AIR LINES BETWEEN WET TANK AND PNEUMATIC CONTROLLER RESTRICTED?

DECISION

YES - Clear restriction, then reconnect air line (Volume 5, WP 0805). Go to Step (11) to verify problem is solved.
 NO - Go to Step (4).

CONTROL PANEL LIGHTS WORK, SYSTEM FAILS TO INFLATE OR DEFLATE - Continued**STEP**

4. IS THE AIR SUPPLY FROM THE VEHICLE AIR COMPRESSOR NORMAL?
 - a. Start engine.

NOTE

If steady mode lights extinguish, air supply is normal.

- b. Repeat inflation sequence with engine running at 1000 rpm for three to five minutes.

CONDITION/INDICATION

IS THE AIR SUPPLY FROM THE VEHICLE AIR COMPRESSOR NORMAL?

DECISION

YES - Two steady mode lights are extinguished, go to Step (5).

NO - Two steady mode lights persist. Perform Air Pressure Builds Slowly troubleshooting (WP 0128).

CONTROL PANEL LIGHTS WORK, SYSTEM FAILS TO INFLATE OR DEFLATE - Continued

STEP

5. IS THERE CONTINUITY BETWEEN PNEUMATIC CONTROLLER SOLENOIDS AND CTIS WIRING HARNESS CANNON PLUG AT ECU?
 - a. Refer to point to point schematics.
 - b. Turn battery switch to OFF position.

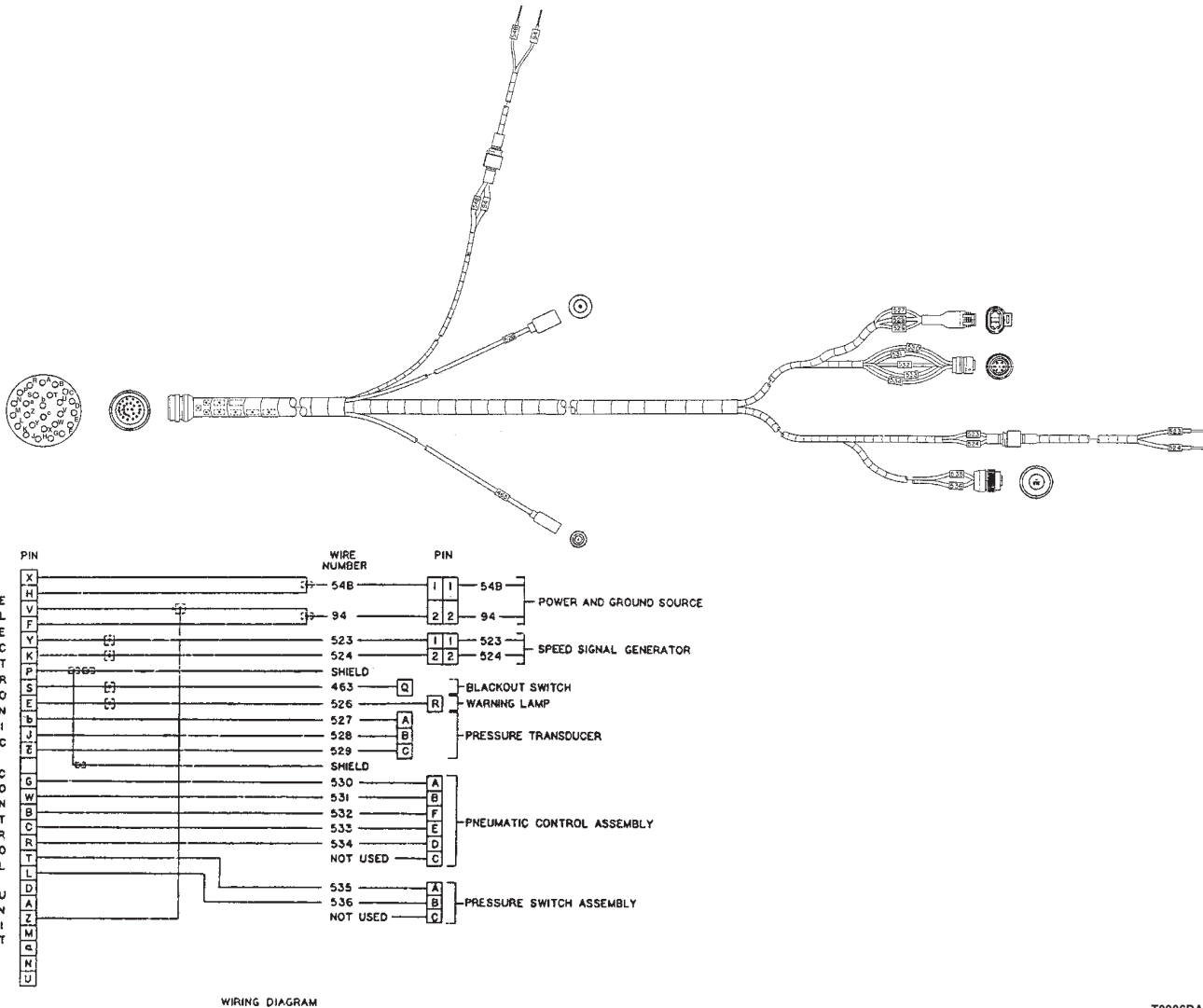

Figure 4. CTIS Wiring Harness.

CAUTION

Turn battery switch to OFF position before disconnecting ECU wiring harness. Failure to do so may result in damage to ECU

- c. Disconnect CTIS wiring harness cannon plug at ECU.
- d. Disconnect connector from pneumatic controller.

CONTROL PANEL LIGHTS WORK, SYSTEM FAILS TO INFLATE OR DEFLATE - Continued

- e. Set multimeter to measure resistance.
- f. Connect multimeter red lead to connector from pneumatic controller.
- g. Connect multimeter black lead to CTIS wiring harness cannon plug.
- h. Meter reading should be less than 200 ohms.

CONDITION/INDICATION

IS THERE CONTINUITY BETWEEN PNEUMATIC CONTROLLER SOLENOIDS AND CTIS WIRING HARNESS CANNON PLUG AT ECU?

DECISION

- YES - Go to Step (6).
- NO - Replace CTIS wiring harness (Volume 2, WP 0322). Go to Step (11) to verify problem is solved.

STEP

- 6. IS THE PNEUMATIC CONTROLLER IN GOOD CONDITION?

Listen for clicking noise while changing CTIS mode.

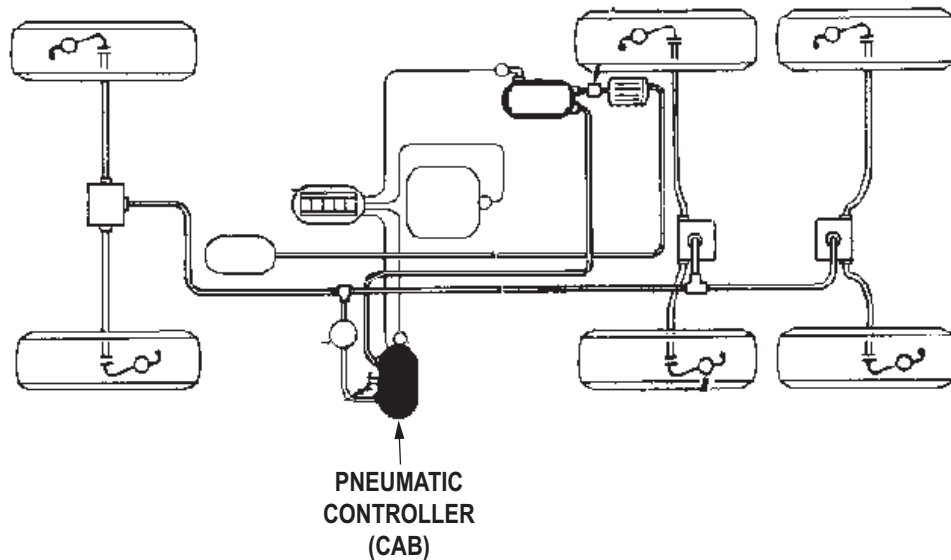

T0901DAA

Figure 5. Pneumatic Controller.

CONDITION/INDICATION

IS THE PNEUMATIC CONTROLLER IN GOOD CONDITION?

DECISION

- YES - Go to Step (7).
- NO - Replace pneumatic controller (Volume 5, WP 0810). Go to Step (11) to verify problem is solved.

CONTROL PANEL LIGHTS WORK, SYSTEM FAILS TO INFLATE OR DEFLATE - Continued

STEP

7. DOES CTIS SYSTEM OPERATE CORRECTLY AFTER THE ELECTRICAL LEAD IS PROPERLY CONNECTED TO PRESSURE SWITCH ON WET TANK?
 - a. Turn battery switch to OFF position.
 - b. Refer to point to point schematics.

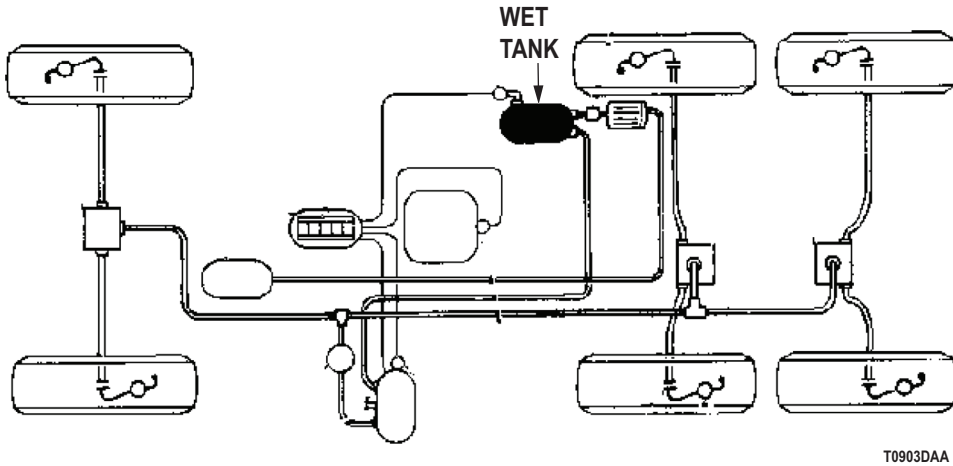

Figure 6. Wet Tank.

- c. Remove electrical lead from pressure switch at wet tank.
- d. Clean the connectors, then reconnect the lead.
- e. Check CTIS operation.

CONDITION/INDICATION

DOES CTIS SYSTEM OPERATE CORRECTLY AFTER THE ELECTRICAL LEAD IS PROPERLY CONNECTED TO PRESSURE SWITCH ON WET TANK?

DECISION

YES - Go to Step (11) to verify problem is solved.
 NO - Go to Step (8).

STEP

8. IS THERE CONTINUITY BETWEEN PRESSURE SWITCH AND CTIS WIRING HARNESS CANNON PLUG AT ECU?
 - a. Refer to point to point schematics.
 - b. Turn battery switch to OFF position.

CONTROL PANEL LIGHTS WORK, SYSTEM FAILS TO INFLATE OR DEFLATE - Continued

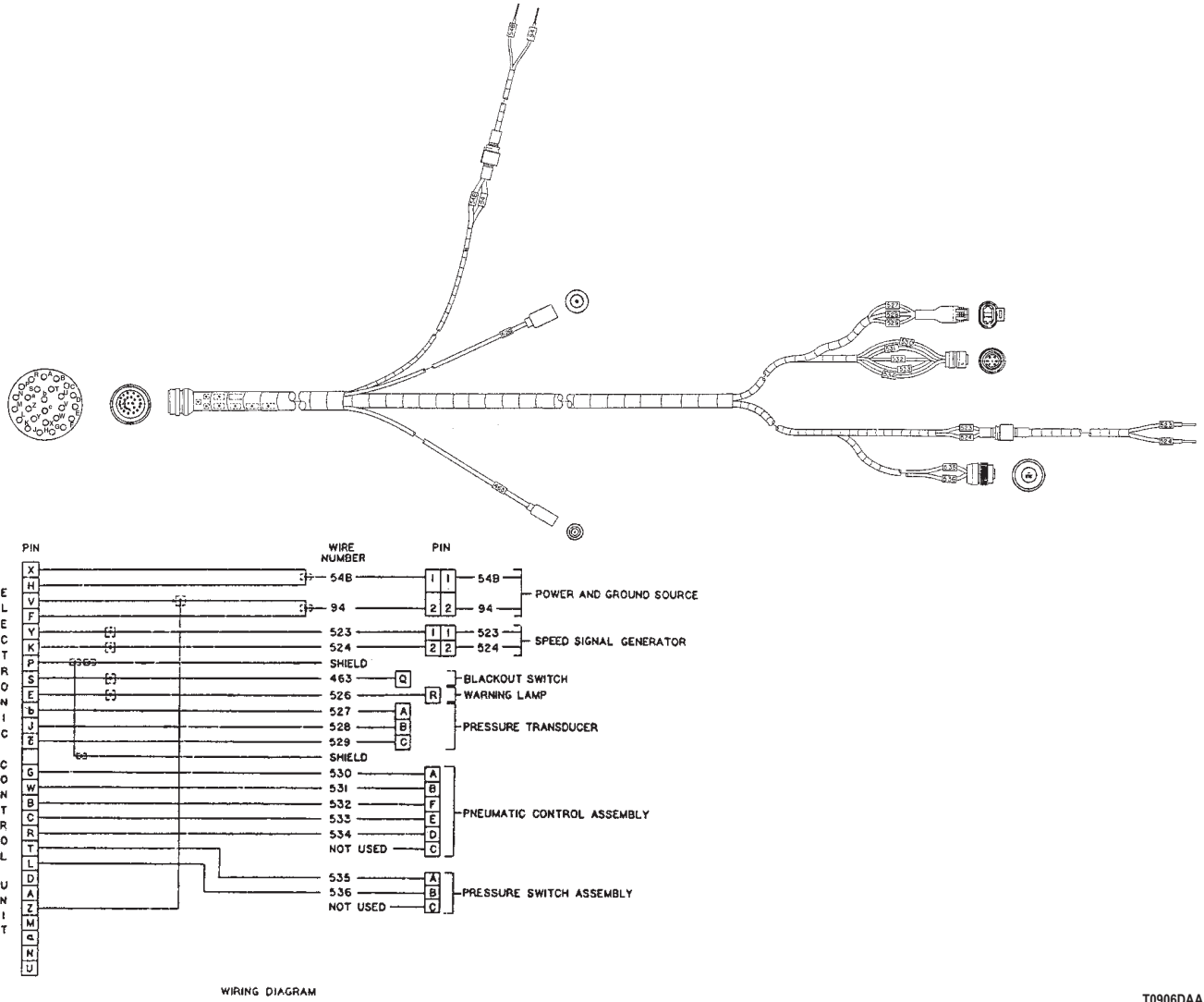

Figure 7. CTIS Wiring Harness.

- c. Connect multimeter red lead to CTIS wiring harness cannon plug.
- d. Connect multimeter black lead to electrical lead at pressure switch.
- e. Meter reading should be less than 200 ohms.

CONDITION/INDICATION

IS THERE CONTINUITY BETWEEN PRESSURE SWITCH AND CTIS WIRING HARNESS CANNON PLUG AT ECU?

DECISION

- YES - Go to Step (9).
- NO - Replace faulty CTIS wiring harness (Volume 2, WP 0322). Go to Step (11) to verify problem is solved.

CONTROL PANEL LIGHTS WORK, SYSTEM FAILS TO INFLATE OR DEFLATE - Continued

STEP

9. IS THERE CONTINUITY BETWEEN PRESSURE SWITCH PINS A AND B WHEN AIR SYSTEM IS AT NORMAL OPERATING PRESSURE?
 - a. Refer to point to point schematics.

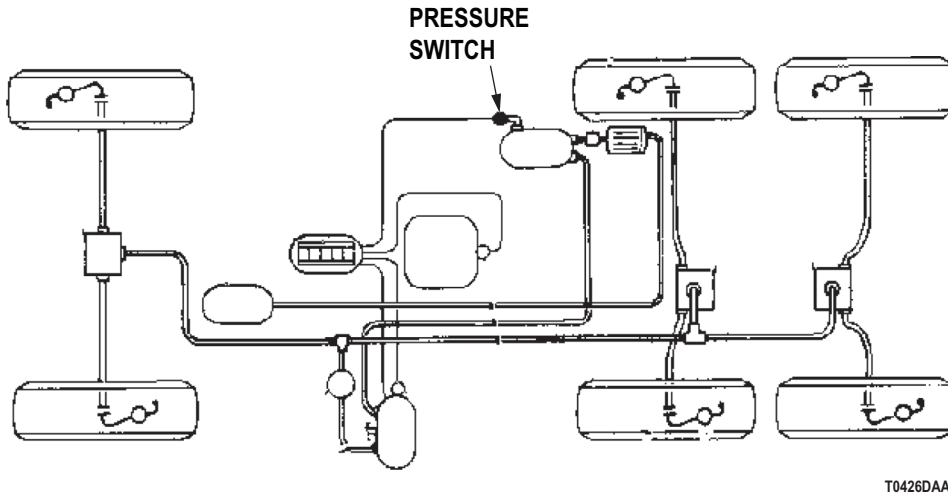

Figure 8. Pressure Switch.

- b. Connect multimeter red lead to pressure switch pin A.
- c. Connect multimeter black lead to pressure switch at pin B.
- d. Use shop air pressure or start and run engine until air pressure reaches 112-120 psi while monitoring the instrument cluster air pressure gauge.
- e. Pressure switch should close.
- f. Meter reading should be less than 20 ohms.

CONDITION/INDICATION

IS THERE CONTINUITY BETWEEN PRESSURE SWITCH PINS A AND B WHEN AIR SYSTEM IS AT NORMAL OPERATING PRESSURE?

DECISION

- YES - Go to Step (10).
 NO - Replace pressure switch (Volume 2, WP 0324). Go to Step (11) to verify problem is solved.

CONTROL PANEL LIGHTS WORK, SYSTEM FAILS TO INFLATE OR DEFLATE - Continued**STEP**

10. IS THERE NO CONTINUITY BETWEEN PRESSURE SWITCH PINS A AND B WHEN AIR SYSTEM IS BELOW NORMAL OPERATING PRESSURE?
- a. Refer to point to point schematics.

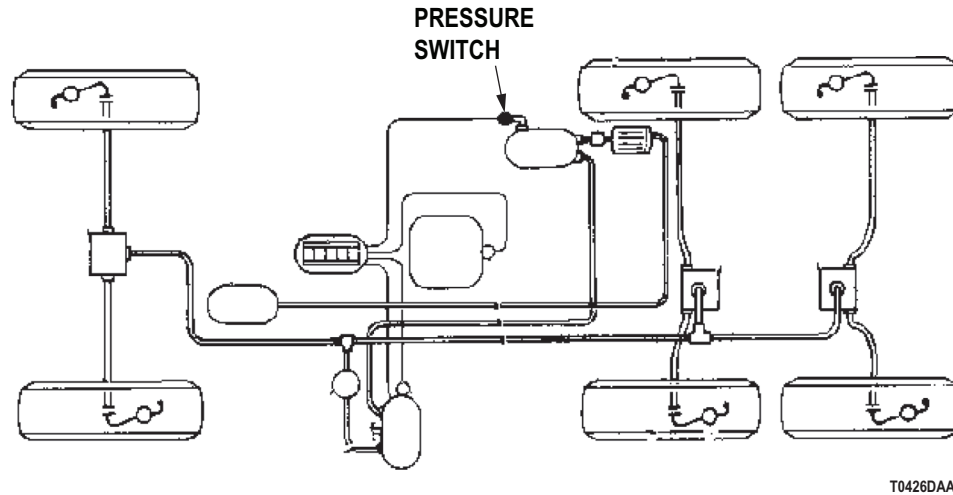

Figure 9. Pressure Switch.

- b. Connect multimeter red lead to pressure switch at pin A.
- c. Connect multimeter black lead to pressure switch at pin B.
- d. Shut off air supply or engine.
- e. Drain secondary tank until air pressure gauge indicates less than 80 psi.
- f. Pressure switch should open.
- g. Meter reading should be greater than 90 ohms.

CONDITION/INDICATION

IS THERE CONTINUITY BETWEEN PRESSURE SWITCH PINS A AND B WHEN AIR SYSTEM IS BELOW NORMAL OPERATING PRESSURE?

DECISION

YES - Go to Step (11) to verify problem is solved.

NO - Replace pressure switch (Volume 2, WP 0324). Go to Step (11) to verify problem is solved.

CONTROL PANEL LIGHTS WORK, SYSTEM FAILS TO INFLATE OR DEFLATE - Continued**STEP**

11. IS YOUR ORIGINAL PROBLEM STILL PRESENT?
- a. Ensure vehicle is returned to normal operating condition.
 - b. Check to see if your original problem still exists.

CONDITION/INDICATION

IS YOUR ORIGINAL PROBLEM STILL PRESENT?

DECISION

YES - Notify supervisor.
NO - Problem fixed.

END OF WORK PACKAGE

FIELD MAINTENANCE
LOSS OF AMBER WARNING LIGHT AND/OR OVERSPEED LIGHT

INITIAL SETUP:**Tools and Special Tools**

Tool Kit, General Mechanic's: Automotive
(Volume 5, WP 0826, Table 1, Item 56)
Multimeter
(Volume 5, WP 0826, Table 1, Item 34)
Test Set, Electronic Systems
(Volume 5, WP 0826, Table 1, Item 51)

References (cont.)

Volume 2, WP 0321
Volume 2, WP 0322
Volume 2, WP 0323
Volume 5, WP 0813

Equipment Condition

Vehicle parked and engine shut down.
(TM 9-2320-272-10)

Personnel Required

(2)

References

Point to Point Schematics

TROUBLESHOOTING PROCEDURE**LOSS OF AMBER WARNING LIGHT AND/OR OVERSPEED LIGHT****NOTE**

- Conduct these malfunction tests if there is a loss of amber warning light or overspeed light. This procedure will check for a faulty light bulb, Electronic Control Unit (ECU), CTIS wiring harness, vehicle wiring harness connections, and speed signal generator.
- The CTIS incorporates an over speed warning and an automatic pressure increase to prevent operation of the vehicle with insufficient tire pressure. This system incorporates a sensor to measure vehicle speed, a panel mounted flashing light, and a connection to the vehicle blackout lights to prevent flashing of the amber warning light when the vehicle is operating under blackout conditions. The ECU periodically measures the speed of the vehicle and compares the speed to programmed limits. If these limits are exceeded, the warning light and automatic pressure increase functions are actuated.

STEP

1. IS THE AMBER WARNING LIGHT OUT WHEN THERE IS AN OVERSPEED PRESSURE CHANGE?

Verify there was an overspeed pressure change.

CONDITION/INDICATION

IS THE AMBER WARNING LIGHT OUT WHEN THERE IS AN OVERSPEED PRESSURE CHANGE?

DECISION

YES - Amber light problem. Go to Step (2).
NO - Overspeed light problem. Go to Step (5).

LOSS OF AMBER WARNING LIGHT AND/OR OVERSPEED LIGHT - Continued**STEP**

2. DOES WARNING LIGHT FLASH WITH BLACKOUT LIGHT SWITCH OFF?
 - a. Ensure vehicle blackout light switch is OFF.

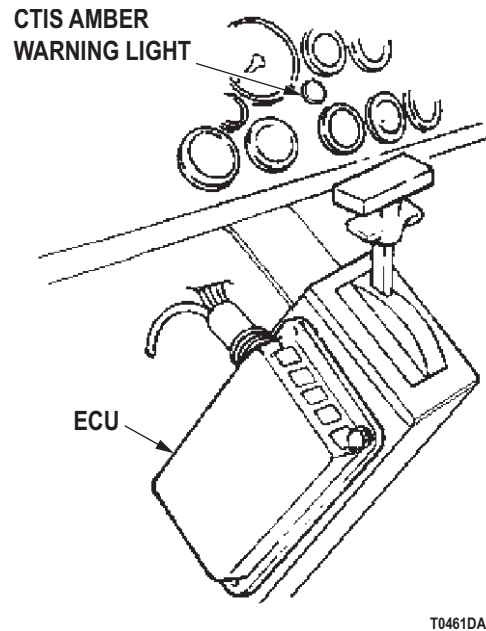

T0461DAA

Figure 1. CTIS Amber Warning Light.

- b. Check condition of warning light.

CONDITION/INDICATION

DOES WARNING LIGHT FLASH WITH BLACKOUT LIGHT SWITCH OFF?

DECISION

YES - Go to Step (3).

NO - Replace amber warning light bulb (Volume 2, WP 0321). Go to Step (7) to verify problem is solved.

LOSS OF AMBER WARNING LIGHT AND/OR OVERSPEED LIGHT - Continued**STEP**

3. DOES WARNING LIGHT FLASH CORRECTLY?
 - a. Select EMERGENCY on ECU to deflate CTIS.

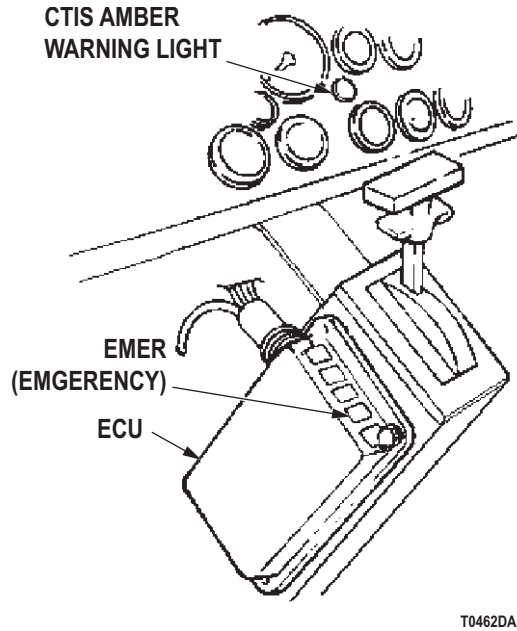

T0462DAA

Figure 2. CTIS Electronic Control Unit.

NOTE

The ECU limits time spent in the EMERGENCY mode to ten minutes. Emergency mode must be re-selected to maintain correct test conditions.

- b. Monitor amber warning light as air pressure is reduced. Verify warning light flashes when emergency pressure is obtained (steady emergency mode light).
- c. Turn on blackout light switch. Verify amber warning light goes out.

CONDITION/INDICATION

DOES WARNING LIGHT FLASH CORRECTLY?

DECISION

YES - Go to Step (7) to verify problem is solved.
 NO - Go to Step (4).

LOSS OF AMBER WARNING LIGHT AND/OR OVERSPEED LIGHT - Continued**STEP****4. DOES WARNING LIGHT FLASH?**

- a. Refer to point to point schematics.

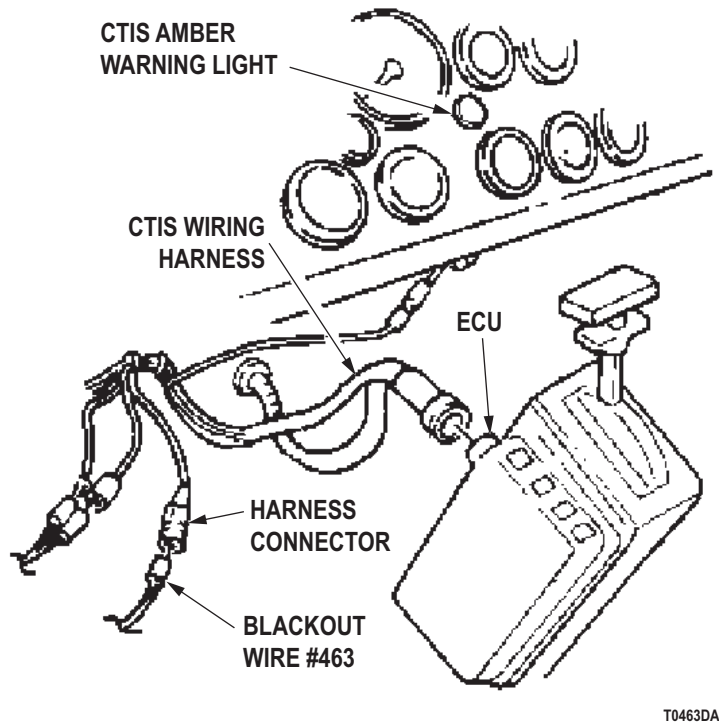

Figure 3. CTIS Wiring Harness.

CAUTION

Turn battery switch to OFF position before disconnecting or connecting ECU wiring harness. Failure to do so may result in damage to ECU.

- b. Turn battery switch OFF.
- c. Disconnect blackout wire #463 from CTIS wiring harness.

CONDITION/INDICATION

DOES WARNING LIGHT FLASH?

DECISION

YES - Go to Step (5).

NO - Replace faulty CTIS wiring harness (Volume 2, WP 0322). Go to Step (7) to verify problem is solved.

LOSS OF AMBER WARNING LIGHT AND/OR OVERSPEED LIGHT - Continued**STEP**

5. IS THERE CONTINUITY BETWEEN SPEED SIGNAL GENERATOR AND ECU CANNON PLUG?
 - a. Refer to point to point schematics.

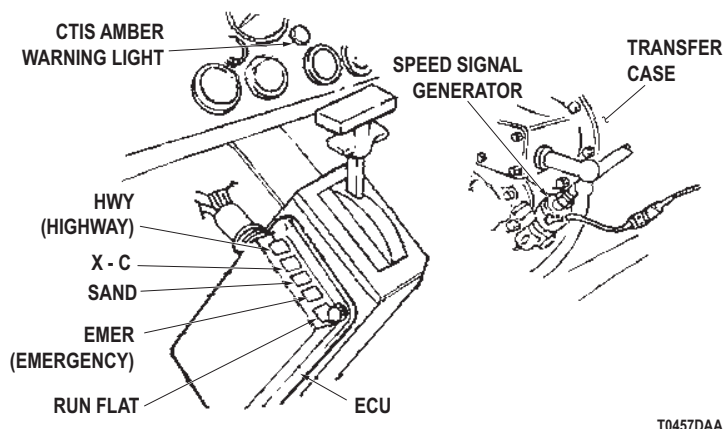

Figure 4. Speed Signal Generator and ECU.

- b. Check connection of electrical lead at speed signal generator on pneumatic controller. Clean and tighten as needed.

CAUTION

Turn battery switch to OFF position before disconnecting or connecting ECU wiring harness. Failure to do so may result in damage to ECU.

- c. Turn battery switch to OFF position.
 - d. Disconnect CTIS wiring harness cannon plug at ECU.
 - e. Disconnect electrical lead at signal generator.
 - f. Set multimeter to measure resistance.
 - g. Connect multimeter red lead to signal generator lead of wiring harness.
 - h. Connect multimeter black lead to harness connector at ECU cannon plug.
 - i. Meter reading should be less than 200 ohms.

CONDITION/INDICATION

IS THERE CONTINUITY BETWEEN SPEED SIGNAL GENERATOR AND ECU CANNON PLUG?

DECISION

YES - Go to Step (6).

NO - Replace faulty CTIS wiring harness (Volume 2, WP 0322). Go to Step (7) to verify problem is solved.

LOSS OF AMBER WARNING LIGHT AND/OR OVERSPEED LIGHT - Continued

STEP

- 6. IS THE SPEED SIGNAL GENERATOR WORKING PROPERLY?
 - a. Refer to point to point schematics.

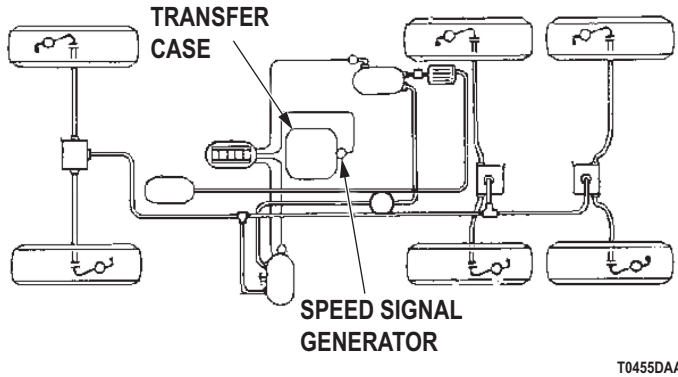

Figure 5. Speed Signal Generator.

- b. Replace the speed signal generator with a known good unit and retest CTIS operation. (Volume 2, WP 0323)
- c. Drive vehicle above 5 mph.
- d. Check CTIS operation.

CONDITION/INDICATION

IS THE SPEED SIGNAL GENERATOR WORKING PROPERLY?

DECISION

- YES - Go to Step (7) to verify problem is solved.
- NO - Replace the Electronic Control Unit (ECU) (Volume 5, WP 0813). Go to Step (7) to verify problem is solved.

STEP

- 7. IS YOUR ORIGINAL PROBLEM STILL PRESENT?
 - a. Ensure vehicle is returned to normal operating condition.
 - b. Check to see if your original problem still exists.

CONDITION/INDICATION

IS YOUR ORIGINAL PROBLEM STILL PRESENT?

DECISION

- YES - Notify supervisor.
- NO - Problem fixed.

END OF WORK PACKAGE

**FIELD MAINTENANCE
SOLID OVERSPEED WARNING LIGHT**

INITIAL SETUP:**Tools and Special Tools**

Tool Kit, General Mechanic's: Automotive
(Volume 5, WP 0826, Table 1, Item 56)
Multimeter
(Volume 5, WP 0826, Table 1, Item 34)
Test Set, Electronic Systems
(Volume 5, WP 0826, Table 1, Item 51)

References (cont.)

Volume 2, WP 0322
Volume 2, WP 0323
Volume 5, WP 0813

Equipment Condition

Vehicle parked and engine shut down.
(TM 9-2320-272-10)

Personnel Required

(2)

References

Point to Point Schematics

TROUBLESHOOTING PROCEDURE**SOLID OVERSPEED WARNING LIGHT****NOTE**

Conduct these malfunction tests if the system gives a solid overspeed warning light. This fault is set because the ECU has seen 25 to 50 ignition cycles without sensing any speed input. Move vehicle at greater than 5 MPH. If light does not go out, perform the following tests. This procedure will check for a faulty Speed Signal Generator, Electronic Control Unit (ECU), and CTIS wiring harness.

SOLID OVERSPEED WARNING LIGHT - Continued

STEP

1. IS THERE CONTINUITY BETWEEN SPEED SIGNAL GENERATOR AND ECU CANNON PLUG?
 - a. Refer to point to point schematics.

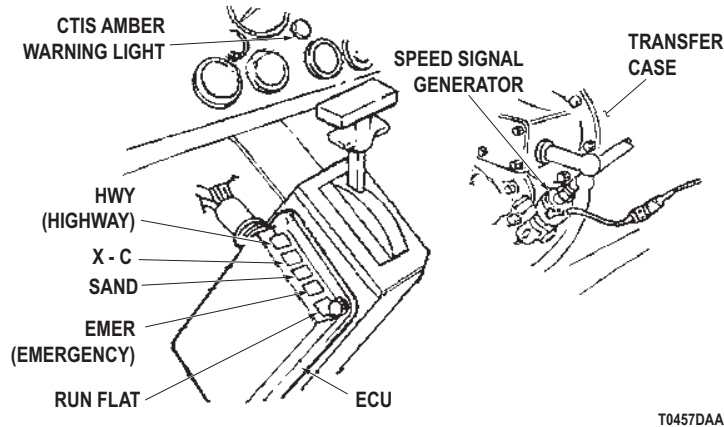

Figure 1. Speed Signal Generator and ECU.

- b. Check connection of electrical lead at speed signal generator on pneumatic controller. Clean and tighten as needed.

CAUTION

Turn battery switch to OFF position before disconnecting or connecting ECU wiring harness. Failure to do so may result in damage to ECU.

- c. Turn battery switch to OFF position.
 - d. Disconnect CTIS wiring harness cannon plug at ECU.
 - e. Disconnect electrical lead at signal generator.
 - f. Set multimeter to measure resistance.
 - g. Connect multimeter red lead to signal generator lead of wiring harness.
 - h. Connect multimeter black lead to harness connector at ECU cannon plug.
 - i. Meter reading should be less than 200 ohms.

CONDITION/INDICATION

IS THERE CONTINUITY BETWEEN SPEED SIGNAL GENERATOR AND ECU CANNON PLUG?

DECISION

- YES - Go to Step (2).
 NO - Replace faulty CTIS wiring harness (Volume 2, WP 0322). Go to Step (3) to verify problem is solved.

SOLID OVERSPEED WARNING LIGHT - Continued

STEP

2. IS THE SPEED SIGNAL GENERATOR WORKING PROPERLY?
 - a. Refer to point to point schematics.

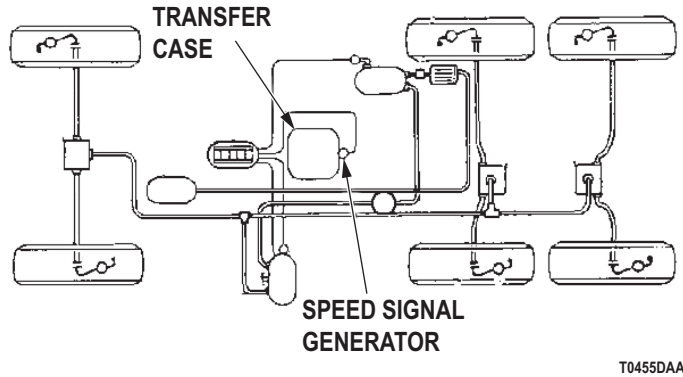

T0455DAA

Figure 2. Speed Signal Generator.

- b. Replace the speed signal generator with a known good unit and retest CTIS operation. (Volume 2, WP 0323)
- c. Drive vehicle above 5 mph.
- d. Check CTIS operation.

CONDITION/INDICATION

IS THE SPEED SIGNAL GENERATOR WORKING PROPERLY?

DECISION

- YES - Go to Step (3) to verify problem is solved.
- NO - Replace the electronic control unit (ECU) (Volume 5, WP 0813). Go to Step (3) to verify problem is solved.

STEP

3. IS YOUR ORIGINAL PROBLEM STILL PRESENT?
 - a. Ensure vehicle is returned to normal operating condition.
 - b. Check to see if your original problem still exists.

CONDITION/INDICATION

IS YOUR ORIGINAL PROBLEM STILL PRESENT?

DECISION

- YES - Notify supervisor.
- NO - Problem fixed.

END OF WORK PACKAGE

**FIELD MAINTENANCE
SYSTEM OVER-INFLATES TIRES**

INITIAL SETUP:**Tools and Special Tools**

Tool Kit, General Mechanic's: Automotive
(Volume 5, WP 0826, Table 1, Item 56)
Multimeter
(Volume 5, WP 0826, Table 1, Item 34)
Test Set, Electronic Systems
(Volume 5, WP 0826, Table 1, Item 51)

References (cont.)

WP 0006
Volume 2, WP 0322
Volume 5, WP 0812
Volume 5, WP 0813

Personnel Required

(2)

Equipment Condition

Vehicle parked and engine shut down.
(TM 9-2320-272-10)

References

Point to Point Schematics

TROUBLESHOOTING PROCEDURE**SYSTEM OVER-INFLATES TIRES****NOTE**

- Conduct these malfunction tests if the system over-inflates tires. This procedure will check for a faulty CTIS wiring harness, Electronic Control Unit (ECU), and pressure transducer.
- The ECU is programmed in conjunction with vehicle air compressor output. This procedure requires air source supplied by vehicle for accurate diagnosis.

SYSTEM OVER-INFLATES TIRES - Continued**STEP**

1. DO TIRE PRESSURES REMAIN THE SAME AFTER MANUALLY BALANCING TIRE PRESSURE?
 - a. Manually measure the pressure in each tire with a pressure gauge to locate all over-inflated tires and to determine the accuracy of system pressure reading.

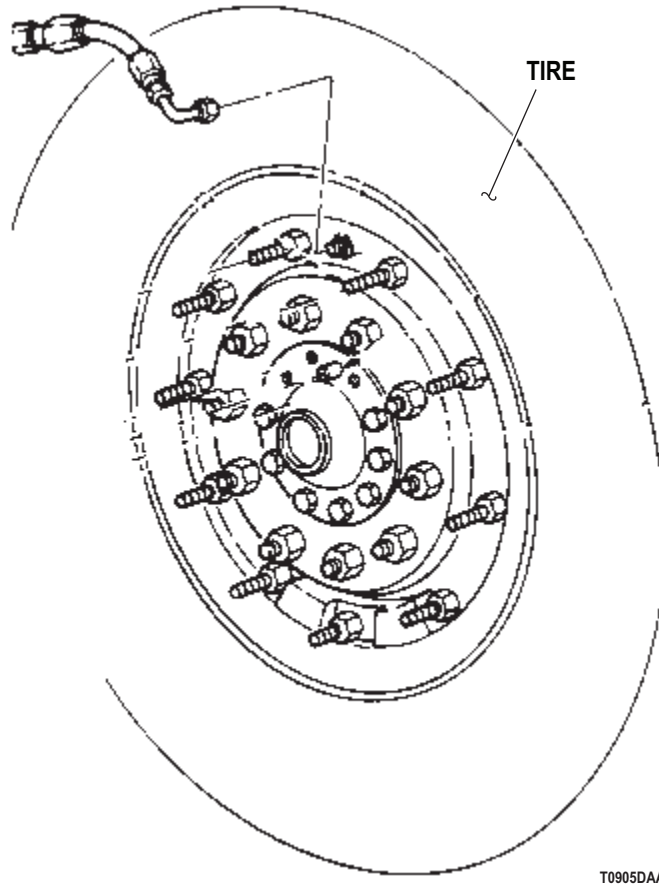

Figure 1. Tire.

CAUTION

When vehicle is connected to an external air source, ensure that air is clean and dry. Dirty and wet air may result in CTIS malfunctions.

- b. Manually balance tire pressures with external air source.

SYSTEM OVER-INFLATES TIRES - Continued**CAUTION**

Do not operate CTIS while vehicle is connected to an external air source. This may result in over-inflation or damage to tires.

- c. Remove external air source and run CTIS.
- d. Manually measure the pressure in each tire with a pressure gauge to locate all over-inflated tires and to determine the accuracy of system pressure reading.

CONDITION/INDICATION

DO TIRE PRESSURES REMAIN THE SAME AFTER MANUALLY BALANCING TIRE PRESSURE?

DECISION

- YES - Go to Step (5) to verify problem is solved.
- NO - Go to Step (2).

SYSTEM OVER-INFLATES TIRES - Continued

STEP

2. IS THERE CONTINUITY BETWEEN PRESSURE TRANSDUCER AND ECU CANNON PLUG?
 - a. Refer to point to point schematics.

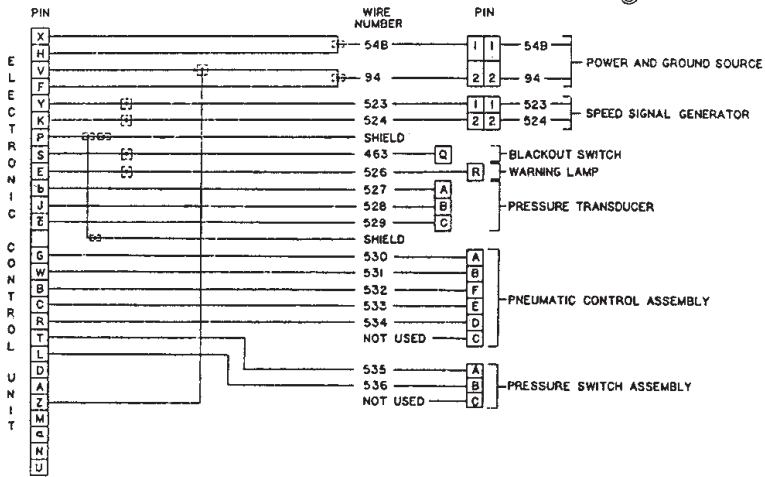
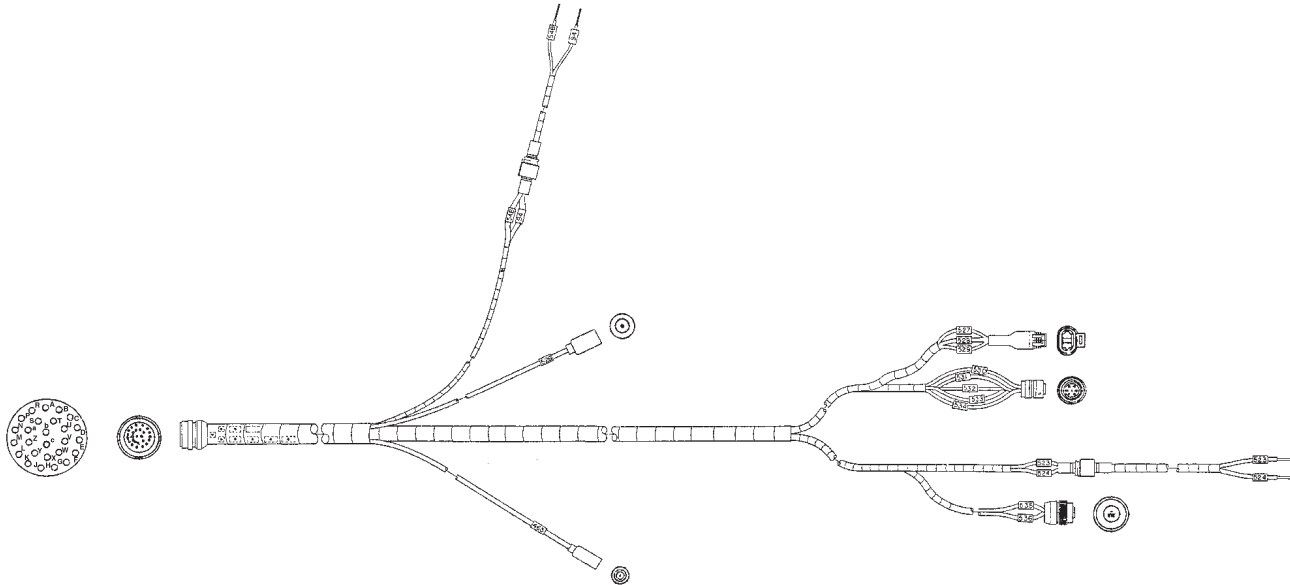

WIRING DIAGRAM

T0907DAA

Figure 2. CTIS Wiring Harness.

- b. Check connection of electrical lead at pressure transducer on pneumatic controller. Clean and tighten as needed.

SYSTEM OVER-INFLATES TIRES - Continued**CAUTION**

Turn battery switch to OFF position before disconnecting or connecting ECU wiring harness. Failure to do so may result in damage to ECU.

- c. Turn battery switch to OFF position.
- d. Disconnect CTIS wiring harness cannon plug at ECU.
- e. Disconnect electrical lead at pressure transducer.
- f. Set multimeter to measure resistance.
- g. Connect multimeter red lead to pressure transducer.
- h. Connect multimeter black lead to pressure transducer lead at ECU cannon plug.
- i. Meter reading should be less than 200 ohms.

CONDITION/INDICATION

IS THERE CONTINUITY BETWEEN PRESSURE TRANSDUCER AND ECU CANNON PLUG?

DECISION

YES - Go to Step (3).

NO - Replace faulty CTIS wiring harness (Volume 2, WP 0322). Go to Step (5) to verify problem is solved.

SYSTEM OVER-INFLATES TIRES - Continued

STEP

3. IS THERE BATTERY VOLTAGE PRESENT AT PINS X AND V ON CTIS WIRING HARNESS CANNON PLUG AT ECU?
 - a. Refer to point to point schematics.

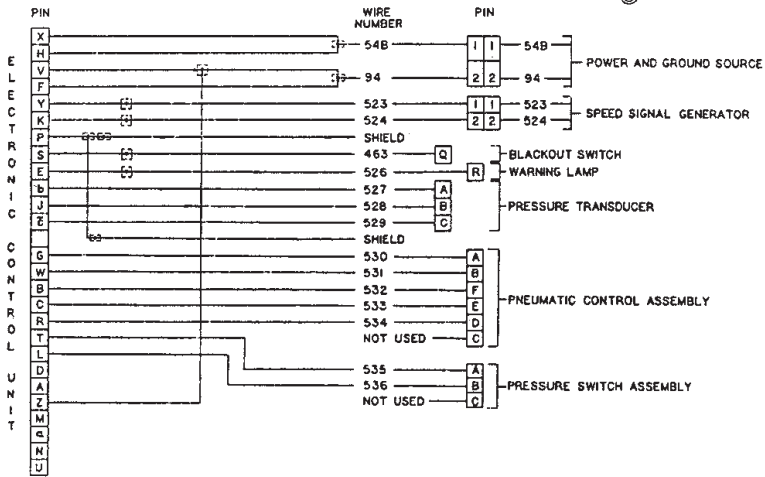
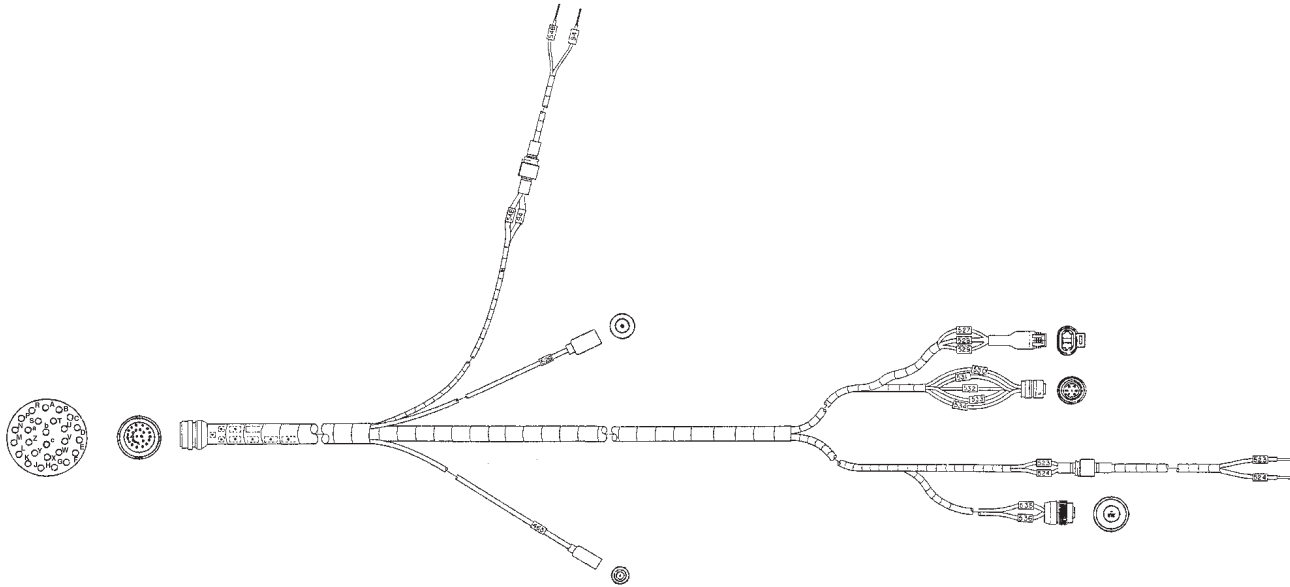

WIRING DIAGRAM

T0907DAA

Figure 3. CTIS Wiring Harness.

SYSTEM OVER-INFLATES TIRES - Continued**CAUTION**

Turn battery switch to OFF position before disconnecting or connecting ECU wiring harness. Failure to do so may result in damage to ECU.

- b. Turn battery switch to OFF position.
- c. Disconnect CTIS wiring harness cannon plug at ECU.
- d. Turn battery switch to ON position.
- e. Set multimeter to measure VDC.
- f. Connect multimeter red lead to CTIS wiring harness cannon plug pin V.
- g. Connect multimeter black lead to CTIS wiring harness cannon plug pin X.
- h. Meter reading should be between 18 and 26 VDC.

CONDITION/INDICATION

IS THERE BATTERY VOLTAGE PRESENT AT PINS X AND V ON CTIS WIRING HARNESS CANNON PLUG AT ECU?

DECISION

YES - Go to Step (4).

NO - Perform Engine Fails To Crank troubleshooting (WP 0006).

SYSTEM OVER-INFLATES TIRES - Continued**STEP**

4. IS THERE 4.75 to 5.25 VDC PRESENT AT PRESSURE TRANSDUCER?
 - a. Refer to point to point schematics.

CAUTION

Turn battery switch to OFF position before disconnecting or connecting ECU wiring harness. Failure to do so may result in damage to ECU.

- b. Turn battery switch to OFF position.
- c. Connect CTIS wiring harness cannon plug at ECU.

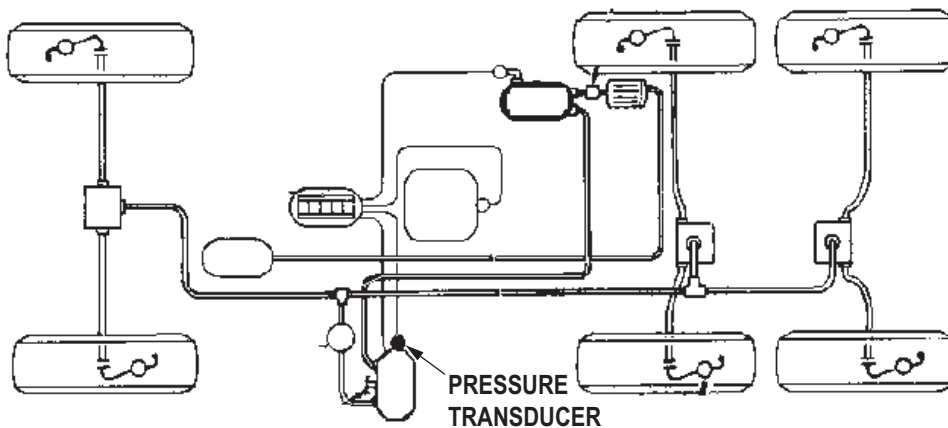

T0902DAA

Figure 4. Pressure Transducer.

- d. Disconnect CTIS wiring harness electrical lead from pressure transducer.
- e. Turn battery switch to ON position.
- f. Connect multimeter red lead to wire at pressure transducer.
- g. Connect multimeter black lead to a known good ground.
- h. Meter reading should be between 4.75 and 5.25 VDC.

SYSTEM OVER-INFLATES TIRES - Continued**CONDITION/INDICATION**

IS THERE 4.75 to 5.25 VDC PRESENT AT PRESSURE TRANSDUCER?

DECISION

NO - Replace electronic control unit (Volume 5, WP 0813). Go to Step (5) to verify problem is solved.

YES - Replace pressure transducer (Volume 5, WP 0812). Go to Step (5) to verify problem is solved.

STEP

5. IS YOUR ORIGINAL PROBLEM STILL PRESENT?
 - a. Ensure vehicle is returned to normal operating condition.
 - b. Check to see if your original problem still exists.

CONDITION/INDICATION

IS YOUR ORIGINAL PROBLEM STILL PRESENT?

DECISION

YES - Notify supervisor.

NO - Problem fixed.

END OF WORK PACKAGE

FIELD MAINTENANCE
SLOW AIR RECOVERY OR OCCASIONAL LOW AIR WARNING DURING BRAKING

INITIAL SETUP:**Tools and Special Tools**

Tool Kit, General Mechanic's: Automotive
(Volume 5, WP 0826, Table 1, Item 56)
Multimeter
(Volume 5, WP 0826, Table 1, Item 34)
Test Set, Electronic Systems
(Volume 5, WP 0826, Table 1, Item 51)

References (cont.)

Volume 2, WP 0322
Volume 2, WP 0324
Volume 5, WP 0813

Equipment Condition

Vehicle parked and engine shut down.
(TM 9-2320-272-10)

Personnel Required

(2)

References

Point to Point Schematics

TROUBLESHOOTING PROCEDURE**SLOW AIR RECOVERY OR OCCASIONAL LOW AIR WARNING DURING BRAKING****NOTE**

Conduct these malfunction tests if air recovery is slow, or there is an occasional low air warning during braking. This procedure will check for the pressure switch lead not making contact, and no continuity between pressure switch and CTIS wiring harness cannon plug at the Electronic Control Unit (ECU). It will also check for a faulty CTIS wiring harness, pressure switch, and ECU.

SLOW AIR RECOVERY OR OCCASIONAL LOW AIR WARNING DURING BRAKING - Continued**STEP**

1. DOES CTIS SYSTEM OPERATE CORRECTLY AFTER THE ELECTRICAL LEAD IS PROPERLY CONNECTED TO PRESSURE SWITCH ON WET TANK?
 - a. Refer to point to point schematics.

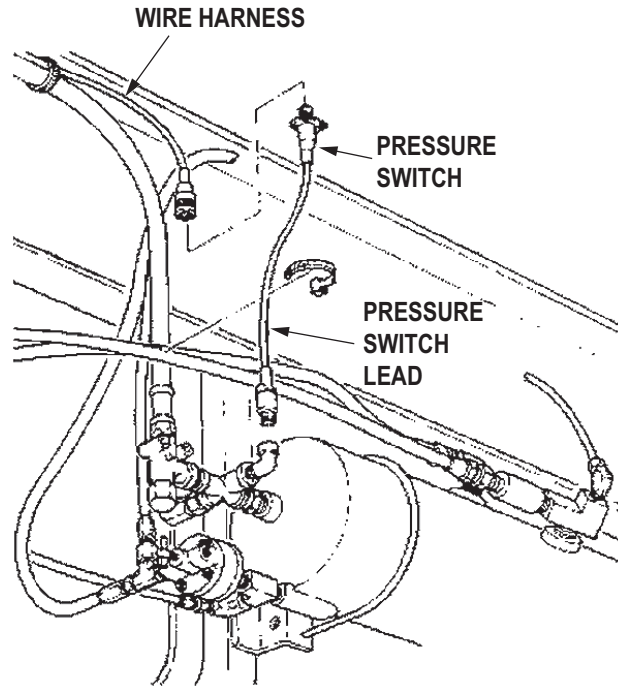

T0469DAA

Figure 1. Pressure Switch.

SLOW AIR RECOVERY OR OCCASIONAL LOW AIR WARNING DURING BRAKING - Continued

- b. Turn battery switch to "OFF" position.
- c. Remove electrical lead from pressure switch at wet tank.
- d. Clean the connectors, then reconnect the lead.
- e. Check CTIS operation.

CONDITION/INDICATION

DOES CTIS SYSTEM OPERATE CORRECTLY AFTER THE ELECTRICAL LEAD IS PROPERLY CONNECTED TO PRESSURE SWITCH ON WET TANK?

DECISION

- YES - Go to Step (6) to verify problem is solved.
- NO - Go to Step (2).

SLOW AIR RECOVERY OR OCCASIONAL LOW AIR WARNING DURING BRAKING - Continued

STEP

2. IS THERE CONTINUITY BETWEEN PRESSURE SWITCH AND CTIS WIRING HARNESS CANNON PLUG AT ECU?
 - a. Refer to point to point schematics.

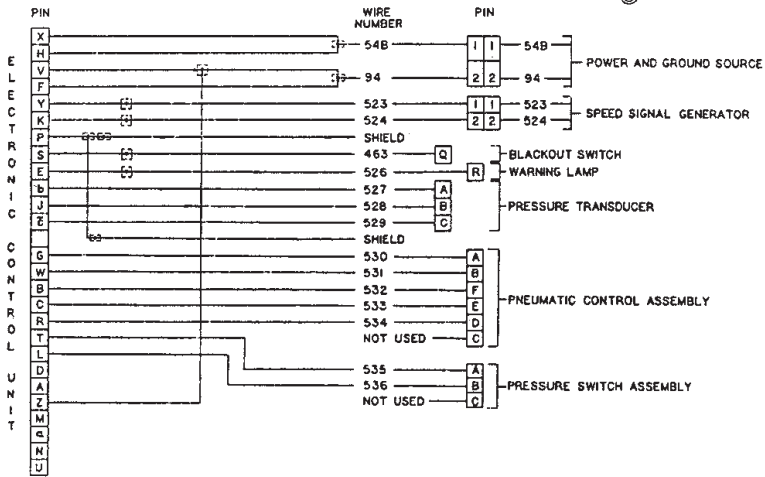
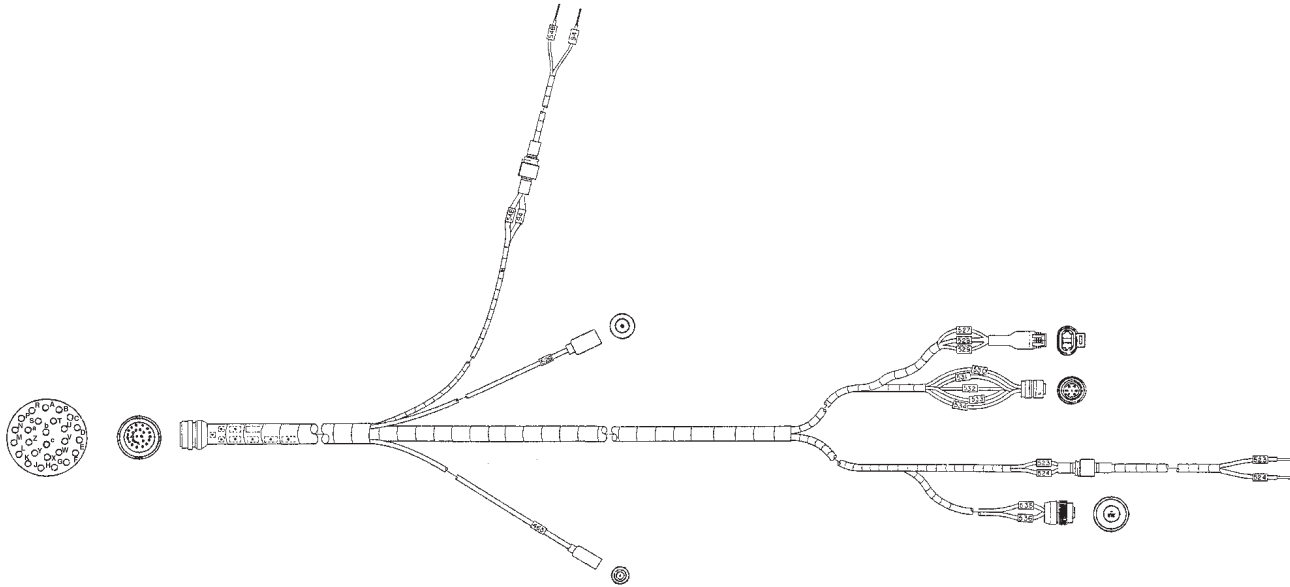

WIRING DIAGRAM

T0908DAA

Figure 2. CTIS Wiring Harness.

SLOW AIR RECOVERY OR OCCASIONAL LOW AIR WARNING DURING BRAKING - Continued

- b. Disconnect harness lead at the pressure switch.
- c. Set multimeter to measure resistance.
- d. Connect multimeter red lead to CTIS wiring harness cannon plug.
- e. Connect multimeter black lead to electrical lead at pressure switch.
- f. Meter reading should be less than 200 ohms.

CONDITION/INDICATION

IS THERE CONTINUITY BETWEEN PRESSURE SWITCH AND CTIS WIRING HARNESS CANNON PLUG AT ECU?

DECISION

YES - Go to Step (3).

NO - Replace faulty CTIS wiring harness (Volume 2, WP 0322). Go to Step (6) to verify problem is solved.

SLOW AIR RECOVERY OR OCCASIONAL LOW AIR WARNING DURING BRAKING - Continued**STEP**

3. IS THERE CONTINUITY BETWEEN PRESSURE SWITCH PINS A AND B WHEN AIR SYSTEM IS AT NORMAL OPERATING PRESSURE?
 - a. Refer to point to point schematics.

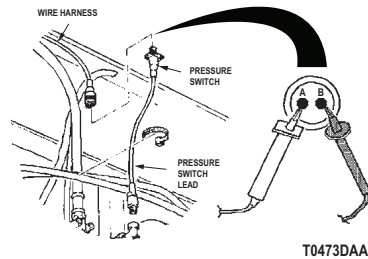

Figure 3. Pressure Switch.

- b. Connect multimeter red lead to pressure switch at pin A.
- c. Connect multimeter black lead to pressure switch at pin B.
- d. Use shop air pressure or start and run engine until air pressure reaches 112-120 psi while monitoring the instrument cluster air pressure gauge.
- e. Pressure switch should be closed.
- f. Meter reading should be less than 20 ohms.

CONDITION/INDICATION

IS THERE CONTINUITY BETWEEN PRESSURE SWITCH PINS A AND B WHEN AIR SYSTEM IS AT NORMAL OPERATING PRESSURE?

DECISION

YES - Go to Step (10).

NO - Replace pressure switch (Volume 2, WP 0324). Go to Step (11) to verify problem is solved.

SLOW AIR RECOVERY OR OCCASIONAL LOW AIR WARNING DURING BRAKING - Continued**STEP**

4. IS THERE NO CONTINUITY BETWEEN PRESSURE SWITCH PINS A AND B WHEN AIR SYSTEM IS BELOW NORMAL OPERATING PRESSURE?
 - a. Refer to point to point schematics.

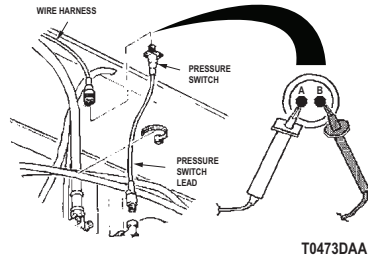

Figure 4. Pressure Switch.

- b. Connect multimeter red lead to pressure switch at pin A.
- c. Connect multimeter black lead to pressure switch at pin B.
- d. Shut off air supply or engine.
- e. Drain secondary tank until air pressure gauge indicates less than 80 psi.
- f. Pressure switch should read open (no continuity).
- g. Meter reading should be greater than 90 ohms.

CONDITION/INDICATION

IS THERE NO CONTINUITY BETWEEN PRESSURE SWITCH PINS A AND B WHEN AIR SYSTEM IS BELOW NORMAL OPERATING PRESSURE?

DECISION

YES - Go to Step (5).

NO - Replace pressure switch (Volume 2, WP 0324). Go to Step (6) to verify problem is solved.

SLOW AIR RECOVERY OR OCCASIONAL LOW AIR WARNING DURING BRAKING - Continued**STEP**

5. IS THE VOLTAGE FROM THE ECU TO THE PRESSURE SWITCH NORMAL?
 - a. Refer to point to point schematics.

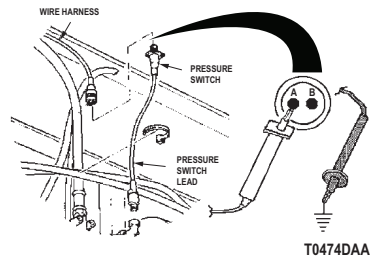

Figure 5. Pressure Switch.

- b. Connect CTIS wiring harness cannon plug to ECU.
- c. Place battery switch to ON position.
- d. Place CTIS switch to ON position.
- e. Set multimeter to measure VDC.
- f. Connect multimeter red lead to pressure switch connector.
- g. Connect multimeter black lead to a known good ground.
- h. Meter reading should be greater than 23 VDC.

CONDITION/INDICATION

IS THE VOLTAGE FROM THE ECU TO THE PRESSURE SWITCH NORMAL?

DECISION

YES - Notify supervisor. It is possible that another troubleshooting work package applies.
 NO - Replace ECU (Volume 5, WP 0813). Go to Step (6) to verify problem is solved.

SLOW AIR RECOVERY OR OCCASIONAL LOW AIR WARNING DURING BRAKING - Continued**STEP**

6. IS YOUR ORIGINAL PROBLEM STILL PRESENT?
 - a. Ensure vehicle is returned to normal operating condition.
 - b. Check to see if your original problem still exists.

CONDITION/INDICATION

IS YOUR ORIGINAL PROBLEM STILL PRESENT?

DECISION

YES - Notify supervisor.
NO - Problem fixed.

END OF WORK PACKAGE

INDEX

Subject

WP Sequence No.-Page No.

A

AIR PRESSURE BUILDS SLOWLY (TAKES EXCESSIVE AMOUNT OF TIME TO BUILD TO 100 PSI (690KPA).....	WP 0128-1
AIR PRESSURE DOES NOT BUILD TO NORMAL OPERATING PRESSURE (ABOVE 80 PSI [552 KPA]) ACCORDING TO GAUGES.....	WP 0127-1
AIR PRESSURE EXCEEDS MAXIMUM (GAUGES SHOW OVER 130 PSI [896 KPA]), SAFETY VALVE OPENS TO RELEASE PRESSURE.....	WP 0129-1
AIR PRESSURE GAUGE INOPERATIVE.....	WP 0102-1
ALL AIR-OPERATED ACCESSORIES DO NOT OPERATE (HORN, WINDSHIELD WIPERS, WINDSHIELD WASHERS, TRANSFER CASE CONTROLS), GAUGES AT NORMAL OPERATING PRESSURE.....	WP 0137-1
ALL GAUGES INOPERATIVE.....	WP 0104-1
ALL VEHICLE ELECTRICAL SYSTEMS INOPERATIVE.....	WP 0085-1
ALTERNATOR OVERCHARGING, BATTERY INDICATOR GAUGE IN RED POSITION.....	WP 0091-1
AUTOMATIC BRAKE OVERHEATS.....	WP 0063-1

B

BATTERY/ALTERNATOR GAUGE INOPERATIVE.....	WP 0108-1
BLACKOUT DRIVE OR BLACKOUT MARKER LIGHT INOPERATIVE.....	WP 0094-1
BRAKES SQUEAL.....	WP 0124-1

C

CENTRAL TIRE INFLATION SYSTEM (CTIS) TROUBLESHOOTING.....	WP 0142-1
CONTAMINATED COOLANT.....	WP 0030-1
CONTINUOUS AXLE OR WHEEL NOISE.....	WP 0045-1
CONTINUOUS WANDERING OR SWAYING (POOR CONTROL).....	WP 0056-1
CONTROL PANEL LIGHTS WORK, SYSTEM FAILS TO INFLATE OR DEFLATE.....	WP 0149-1
COOLING FAN DOES NOT OPERATE, ENGINE TEMPERATURE ABOVE 195°F (91°C) AS INDICATED BY TEMPERATURE GAUGE.....	WP 0138-1
COOLING FAN DOES NOT STOP RUNNING, ENGINE TEMPERATURE BELOW NORMAL OPERATING RANGE (OVERRIDE BOLT NOT INSTALLED).....	WP 0139-1
CTIS TROUBLESHOOTING INDEX.....	WP 0143-1

D

DIRT OR METAL PARTICLES IN TRANSMISSION OIL.....	WP 0037-1
DOOR LOCK WILL NOT OPERATE.....	WP 0082-1
DRAG BRAKE DOES NOT OPERATE.....	WP 0061-1
DUMP BODY WILL NOT HOLD IN RAISED POSITION.....	WP 0076-1
DUMP BODY WILL NOT LOWER.....	WP 0075-1
DUMP BODY WILL NOT RAISE.....	WP 0074-1
DUMP HYDRAULIC PUMP NOISY.....	WP 0077-1

E

ENGINE AND VEHICLE ELECTRICAL SYSTEMS MALFUNCTIONING.....	WP 0083-1
ENGINE CRANKS BUT DOES NOT START.....	WP 0007-1
ENGINE CRANKS BUT WILL NOT START IN COLD WEATHER (FUEL SYSTEM OPERATING PROPERLY).....	WP 0021-1
ENGINE DOES NOT REACH NORMAL OPERATING TEMPERATURE.....	WP 0027-1

<u>Subject</u>	<u>WP Sequence No.-Page No.</u>
ENGINE FAILS TO CRANK.....	WP 0006-1
ENGINE FAILS TO STOP.....	WP 0011-1
ENGINE IDLE ROUGH OR ERRATIC.....	WP 0013-1
ENGINE OIL CONTAMINATED.....	WP 0018-1
ENGINE OVERHEATS.....	WP 0028-1
ENGINE RUNS, BUT MISFIRES.....	WP 0012-1
ENGINE STOPS DURING NORMAL OPERATION.....	WP 0009-1
ENGINE STOPS WHEN ACCELERATOR IS RETURNED TO IDLE POSITION.....	WP 0010-1
ENGINE SURGES.....	WP 0015-1
ENGINE WILL NOT CRANK; SOME ELECTRICAL SYSTEMS INOPERATIVE OR WEAK.....	WP 0084-1
EQUIPMENT DESCRIPTION AND DATA.....	WP 0002-1
EXCESSIVE EXHAUST NOISE.....	WP 0025-1
EXCESSIVE FUEL CONSUMPTION.....	WP 0020-1
EXCESSIVE NOISE.....	WP 0042-1
EXCESSIVE NOISE DURING SHIFTING.....	WP 0031-1
EXCESSIVE OIL CONSUMPTION.....	WP 0016-1
EXCESSIVE PLAY IN STEERING WHEEL.....	WP 0054-1
EXCESSIVE PROPELLER AND DRIVE SHAFTS NOISE OR VIBRATION.....	WP 0044-1
EXCESSIVE VIBRATION.....	WP 0043-1
EXCESSIVE VIBRATION OR CLUNKING.....	WP 0019-1
EXCESSIVELY LOOSE LIFTING SHACKLE.....	WP 0048-1
EXHAUST COLOR BLACK DURING NORMAL OPERATION AND IDLE.....	WP 0024-1
EXHAUST COLOR BLUE DURING NORMAL OPERATION.....	WP 0022-1
EXHAUST COLOR WHITE DURING NORMAL OPERATION.....	WP 0023-1
EXHAUST FUMES IN CAB.....	WP 0026-1
F	
FIVE INDICATOR LIGHTS FLASHING.....	WP 0146-1
FOUR PRESSURE MODE LIGHTS FLASHING.....	WP 0145-1
FRONT WHEEL DRIVE DOES NOT ENGAGE (FRONT WHEEL DRIVE LOCK-IN SWITCH ENGAGED AND TRANSFER CASE SHIFT LEVER IN HIGH POSITION).....	WP 0140-1
FRONT WINCH OPERATES AT ONE SPEED ONLY.....	WP 0064-1
FUEL GAUGE INOPERATIVE.....	WP 0107-1
G	
GENERAL INFORMATION.....	WP 0001-1
GENERAL TROUBLESHOOTING.....	WP 0004-1
GENERAL TROUBLESHOOTING INDEX.....	WP 0005-1
H	
HARD SHIFTING OF TRANSFER CASE.....	WP 0040-1
HARD STEERING.....	WP 0052-1
HARSH OR HARD RIDE.....	WP 0057-1
HEADLAMP (BOTH SIDE) INOPERATIVE.....	WP 0093-1
HEADLAMP (ONE SIDE) INOPERATIVE.....	WP 0092-1
HEATER WILL NOT OPERATE IN LOW OR HIGH POSITION.....	WP 0116-1
HEATER WILL NOT OPERATE WITH SWITCH IN HIGH POSITION (LOW POSITION OPERATION NORMAL).....	WP 0115-1
HEATER WILL NOT OPERATE WITH SWITCH IN LOW POSITION (HIGH POSITION OPERATION NORMAL).....	WP 0114-1
HORN DOES NOT WORK (GAUGES AT NORMAL OPERATING PRESSURE, WARNING BUZZER NOT SOUNDING).....	WP 0141-1

<u>Subject</u>	<u>WP Sequence No.-Page No.</u>
HORN INOPERATIVE.....	WP 0109-1
I	
INDIVIDUAL LIGHTS DO NOT LIGHT WITH DIRECTIONAL SIGNAL LEVER IN ANY POSITION.....	WP 0097-1
INSUFFICIENT BRAKES (VEHICLE STOPPING DISTANCE TOO LONG, NO APPARENT AIR SYSTEM FAILURE WITH GAUGES AT NORMAL OPERATING PRESSURE, WARNING BUZZER NOT SOUNDING).....	WP 0120-1
L	
LOOSE SPARE TIRE CARRIER.....	WP 0049-1
LOSS OF AMBER WARNING LIGHT AND/OR OVERSPEED LIGHT.....	WP 0150-1
LOSS OF COOLANT.....	WP 0029-1
LOW AIR PRESSURE WARNING BUZZER WILL NOT SHUT OFF (AIR PRESSURE GAUGES AT NORMAL SYSTEM PRESSURE).....	WP 0110-1
LOW AIR PRESSURE WARNING BUZZER WILL NOT SHUT OFF AND PARKING BRAKE WARNING LIGHT FLASHES WITH HAND/PARKING BRAKE IN ANY POSITION (AIR PRESSURE NORMAL).....	WP 0111-1
LOW OIL PRESSURE.....	WP 0017-1
LOW TRANSMISSION OIL PRESSURE.....	WP 0032-1
N	
NO AIR PRESSURE (WARNING BUZZER SOUNDING, AIR PRESSURE NOT BUILDING TO NORMAL OPERATING RANGE AS INDICATED BY GAUGES).....	WP 0126-1
NO ALTERNATOR OUTPUT (100 AMP ALTERNATOR).....	WP 0090-1
NO CAB HEAT (COOLANT TEMPERATURE GAUGE READS NORMAL).....	WP 0117-1
NO LIGHTS OPERATE WITH DIRECTIONAL SIGNAL CONTROL LEVER IN ANY POSITION.....	WP 0098-1
NO OR LOW ALTERNATOR OUTPUT.....	WP 0089-1
NO RESPONSE TO SHIFT LEVER MOVEMENT.....	WP 0034-1
O	
OIL PRESSURE GAUGE INOPERATIVE (OIL LEVEL IS CORRECT).....	WP 0103-1
OIL THROWN FROM TRANSMISSION DIPSTICK TUBE.....	WP 0038-1
ONE OR MORE TRAILER LIGHTS INOPERATIVE.....	WP 0113-1
P	
PARKING BRAKE DOES NOT HOLD VEHICLE ON GRADE.....	WP 0118-1
PARKING BRAKE DRAGS, AS INDICATED BY SMOKING OR BURNING SMELL.....	WP 0119-1
PINTLE HOOK DOES NOT TURN.....	WP 0047-1
POOR ACCELERATION AND/OR LACK OF POWER.....	WP 0014-1
PRIMARY AIR SYSTEM FAILS TO MAINTAIN PRESSURE (NO MAJOR LEAKS, AIR CAN BE HEARD ESCAPING INTO AIR INTAKE STACK, PARKING BRAKE APPLIED).....	WP 0132-1
PRIMARY PRESSURE GAUGE READS NO PRESSURE, LOW PRESSURE, OR BUILDS TO NORMAL OPERATING PRESSURE SLOWLY. SECONDARY PRESSURE GAUGE READS NORMAL (ENGINE IDLING, BRAKE PEDAL NOT APPLIED).....	WP 0130-1
PROTECTIVE CONTROL BOX ASSEMBLY TEST.....	WP 0100-1
PTO EXCESSIVELY NOISY.....	WP 0067-1
PTO LEAKING LUBRICANT.....	WP 0069-1
PTO SHIFTS HARD.....	WP 0068-1

Subject

WP Sequence No.-Page No.

R

RADIO INTERFERENCE.....	WP 0070-1
REAR WINCH CABLE TENSIONER WILL NOT OPERATE.....	WP 0065-1
ROUGH SHIFTING.....	WP 0035-1

S

SECONDARY AIR SYSTEM FAILS TO MAINTAIN PRESSURE (NO MAJOR LEAKS, AIR CAN BE HEARD ESCAPING INTO AIR INTAKE STACK, PARKING BRAKE APPLIED).....	WP 0133-1
SECONDARY PRESSURE GAUGE READS NO PRESSURE, LOW PRESSURE, OR BUILDS TO NORMAL OPERATING PRESSURE SLOWLY. PRIMARY PRESSURE GAUGE READS NORMAL (ENGINE IDLING, BRAKE PEDAL NOT APPLIED).....	WP 0131-1
SHIMMY.....	WP 0055-1
SIDE PANEL CANNOT BE LOCKED IN RETRACT POSITION.....	WP 0080-1
SIDE PANELS HARD TO RETRACT OR EXPAND.....	WP 0079-1
SLOW AIR RECOVERY OR OCCASIONAL LOW AIR WARNING DURING BRAKING.....	WP 0153-1
SOLENOID OPERATES, STARTER OPERATES, BUT ENGINE CRANKS SLOWLY.....	WP 0087-1
SOLID OVERSPEED WARNING LIGHT.....	WP 0151-1
SPEEDOMETER OR TACHOMETER NOISY OR ERRATIC.....	WP 0101-1
SPRING BRAKE WARNING LIGHT INOPERATIVE WITH SPRING BRAKE OVERRIDE ENGAGED.....	WP 0112-1
SPRING BRAKES DO NOT RELEASE (VEHICLE BRAKES GRAB OR DRAG).....	WP 0135-1
SPRING BRAKES DO NOT SET (GAUGES AT NORMAL OPERATING PRESSURES, AIR EXHAUSTING NOT HEARD WHEN PARKING BRAKE APPLIED).....	WP 0136-1
SPRING LEAF DEFECT.....	WP 0058-1
STARTER CRANKS ENGINE SLOWLY, HARD TO START.....	WP 0008-1
STARTER MOTOR INOPERATIVE.....	WP 0086-1
STARTER MOTOR INOPERATIVE; NO SOLENOID THUMP.....	WP 0088-1
STOPLIGHT INOPERATIVE (SERVICE OR BLACKOUT).....	WP 0095-1
SYSTEM FAILS TO DEFLATE, PARTIALLY DEFLATES, OR TIRE PRESSURES ARE IMBALANCED.....	WP 0148-1
SYSTEM OPERATES INCORRECTLY IN ONE OR MORE POSITIONS OF DIRECTIONAL SIGNAL CONTROL LEVER.....	WP 0099-1
SYSTEM OVER-INFLATES TIRES.....	WP 0152-1
SYSTEM REPEATEDLY RESUMES CYCLING 30 SECONDS AFTER MODE LIGHT STOPS FLASHING.....	WP 0147-1

T

TAIL AND MARKER LIGHTS INOPERATIVE.....	WP 0096-1
TAILGATE WILL NOT OPEN.....	WP 0078-1
TEMPERATURE GAUGE INOPERATIVE (COOLANT).....	WP 0106-1
THEORY OF OPERATION.....	WP 0003-1
TOWING PINTLE DOES NOT LATCH OR LOCK.....	WP 0046-1
TRAILER WILL NOT HITCH TO FIFTH WHEEL.....	WP 0071-1
TRANSFER CASE LEAKING OIL.....	WP 0041-1
TRANSMISSION OIL DIRTY, FOAMY, AND/OR MILKY.....	WP 0039-1
TRANSMISSION OIL LEAKING.....	WP 0033-1
TRANSMISSION OVERHEATS AS INDICATED BY TRANSMISSION TEMPERATURE GAUGE.....	WP 0036-1
TRANSMISSION TEMPERATURE GAUGE INOPERATIVE.....	WP 0105-1

<u>Subject</u>	<u>WP Sequence No.-Page No.</u>
TWO PRESSURE MODES INDICATED WITH STEADY MODE LIGHTS.....	WP 0144-1
U	
UNEVEN TIRE WEAR.....	WP 0050-1
V	
VAN BODY NOT WATERPROOF OR LIGHT TIGHT.....	WP 0081-1
VEHICLE PULLS RIGHT OR LEFT WHEN APPLYING BRAKES.....	WP 0121-1
VEHICLE REAR BRAKES GRAB OR DRAG.....	WP 0122-1
VEHICLE ROLLS WHILE OPERATING REAR WINCH.....	WP 0066-1
VEHICLE VIBRATES, CHATTERS, OR BOUNCES WHEN BRAKES ARE APPLIED....	WP 0123-1
VEHICLE WANDERS OR PULLS TO ONE SIDE.....	WP 0053-1
W	
WARNING BUZZER FAILS TO SOUND OR FAILS TO SHUT OFF ON LOW PRESSURE (BELOW 55-65 PSI [379-448 KPA]), AIR PRESSURE SYSTEM OPERATING NORMALLY.....	WP 0134-1
WARNING BUZZER SOUNDS WHEN BRAKES ARE APPLIED (PRIMARY & SECONDARY GAUGE PRESSURE DROPS BELOW 55-65 PSI [379-448 KPA]).....	WP 0125-1
WHEEL SHIMMY OR WOBBLE.....	WP 0051-1
WINCH DOES NOT OPERATE.....	WP 0059-1
WINCH OPERATES IN ONE DIRECTION ONLY.....	WP 0060-1
WINCH WILL NOT HOLD LOAD.....	WP 0062-1
WRECKER HYDRAULIC PUMP NOISY.....	WP 0073-1
WRECKER HYDRAULIC SYSTEM DOES NOT OPERATE.....	WP 0072-1

RECOMMENDED CHANGES TO PUBLICATIONS AND BLANK FORMS						Use Part II (reverse) for Repair Parts and Special Tool Lists (RPSTL) and Supply Catalogs/Supply Manuals (SC/SM).	DATE <i>Date you filled out this form.</i>
For use of this form, see AR 25-30; the proponent agency is OAASA.							
TO (Forward to proponent of publication or form) (Include ZIP Code) U.S. Army TACOM Life Cycle Management Command ATTN: AMSTA-LCL-MPP/TECH PUBS 6501 E. 11 Mile Road, Warren, MI 48397-5000						FROM (Activity and location) (Include ZIP Code) <i>Your mailing address</i>	
PART I – ALL PUBLICATIONS (EXCEPT RPSTL AND SC/SM) AND BLANK FORMS							
PUBLICATION/FORM NUMBER <i>TM Number</i>						DATE <i>Date of the TM</i>	TITLE <i>Title of the TM</i>
ITEM	PAGE	PARA-GRAPH	LINE	FIGURE NO.	TABLE	RECOMMENDED CHANGES AND REASON (Exact wording of recommended change must be given)	
	0007-3					<i>Figure 2, Item 9 should show a lockwasher. Currently shows a flat washer.</i>	
	0018-2					<i>Cleaning and inspection, Step 6, reference to governor support pin (14) is wrong reference. Reference should be change to (12).</i>	
<h1>SAMPLE</h1>							
TYPED NAME, GRADE OR TITLE <i>Your Name</i>						TELEPHONE EXCHANGE/AUTOVON, PLUS EXTENSION <i>Your Phone Number</i>	SIGNATURE <i>Your Signature</i>

TO (Forward direct to addressee listed in publication) U.S. Army TACOM Life Cycle Management Command ATTN: AMSTA-LCL-MPP/TECH PUBS 6501 E. 11 Mile Road, Warren, MI 48397-5000	FROM (Activity and location) (Include ZIP Code) <i>Your Address</i>	DATE <i>Date you filled out this form</i>
--	---	---

PART II – REPAIR PARTS AND SPECIAL TOOL LISTS AND SUPPLY CATALOGS/SUPPLY MANUALS

PUBLICATION NUMBER <i>TM Number</i>	DATE <i>Date of the TM</i>	TITLE <i>Title of the TM</i>
--	-------------------------------	---------------------------------

PAGE NO.	COLM NO.	LINE NO.	NATIONAL STOCK NUMBER	REFERENCE NO.	FIGURE NO.	ITEM NO.	TOTAL NO. OF MAJOR ITEMS SUPPORTED	RECOMMENDED ACTION
<h1>SAMPLE</h1>								

PART III – REMARKS (Any general remarks, or recommendations, or suggestions for improvement of publications and blank forms. Additional blank sheets may be used if more space is needed.)

TYPED NAME, GRADE OR TITLE <i>Your Name</i>	TELEPHONE EXCHANGE/AUTOVON, PLUS EXTENSION <i>Your Phone Number</i>	SIGNATURE <i>Your Signature</i>
--	--	------------------------------------

RECOMMENDED CHANGES TO PUBLICATIONS AND BLANK FORMS						Use Part II (reverse) for Repair Parts and Special Tool Lists (RPSTL) and Supply Catalogs/Supply Manuals (SC/SM).	DATE
For use of this form, see AR 25-30; the proponent agency is OAASA							
TO (Forward to proponent of publication or form) (Include ZIP Code) U.S. Army TACOM Life Cycle Management Command ATTN: AMSTA-LCL-MPP/TECH PUBS 6501 E. 11 Mile Road, Warren, MI 48397-5000						FROM (Activity and location) (Include ZIP Code)	
PART I – ALL PUBLICATIONS (EXCEPT RPSTL AND SC/SM) AND BLANK FORMS							
PUBLICATION/FORM NUMBER TM 9-2320-272-1						DATE 10 September 2012	TITLE Truck, 5-Ton, 6X6, M939A1, And M939A2 Series Trucks (Diesel), Field Maintenance Manual
	PAGE	PARA-GRAPH	LINE	FIGURE NO.	TABLE	RECOMMENDED CHANGES AND REASON	
TYPED NAME, GRADE OR TITLE					TELEPHONE EXCHANGE/AUTOVON, PLUS EXTENSION		SIGNATURE

TO (Forward direct to addressee listed in publication) U.S. Army TACOM Life Cycle Management Command ATTN: AMSTA-LCL-MPP/TECH PUBS 6501 E. 11 Mile Road, Warren, MI 48397-5000	FROM (Activity and location) (Include ZIP Code)	DATE
--	--	-------------

PART II – REPAIR PARTS AND SPECIAL TOOL LISTS AND SUPPLY CATALOGS/SUPPLY MANUALS

PUBLICATION/FORM NUMBER TM 9-2320-272-1	DATE 10 September 2012	TITLE Truck, 5-Ton, 6X6, M939A1, And M939A2 Series Trucks (Diesel), Field Maintenance Manual
---	----------------------------------	--

PAGE NO.	COLM NO.	LINE NO.	NATIONAL STOCK NUMBER	REFERENCE NO.	FIGURE NO.	ITEM NO.	TOTAL NO. OF MAJOR ITEMS SUPPORTED	RECOMMENDED ACTION

PART III – REMARKS (Any general remarks, or recommendations, or suggestions for improvement of publications and blank forms. Additional blank sheets may be used if more space is needed.)

TYPED NAME, GRADE OR TITLE	TELEPHONE EXCHANGE/AUTOVON, PLUS EXTENSION	SIGNATURE
----------------------------	--	-----------

RECOMMENDED CHANGES TO PUBLICATIONS AND BLANK FORMS						Use Part II (reverse) for Repair Parts and Special Tool Lists (RPSTL) and Supply Catalogs/Supply Manuals (SC/SM).	DATE
For use of this form, see AR 25-30; the proponent agency is OAASA							
TO (Forward to proponent of publication or form) (Include ZIP Code) U.S. Army TACOM Life Cycle Management Command ATTN: AMSTA-LCL-MPP/TECH PUBS 6501 E. 11 Mile Road, Warren, MI 48397-5000						FROM (Activity and location) (Include ZIP Code)	
PART I – ALL PUBLICATIONS (EXCEPT RPSTL AND SC/SM) AND BLANK FORMS							
PUBLICATION/FORM NUMBER TM 9-2320-272-1						DATE 10 September 2012	TITLE Truck, 5-Ton, 6X6, M939A1, And M939A2 Series Trucks (Diesel), Field Maintenance Manual
ITEM	PAGE	PARA-GRAPH	LINE	FIGURE NO.	TABLE	RECOMMENDED CHANGES AND REASON	
TYPED NAME, GRADE OR TITLE					TELEPHONE EXCHANGE/AUTOVON, PLUS EXTENSION		SIGNATURE

TO <i>(Forward direct to addressee listed in publication)</i> U.S. Army TACOM Life Cycle Management Command ATTN: AMSTA-LCL-MPP/TECH PUBS 6501 E. 11 Mile Road, Warren, MI 48397-5000	FROM <i>(Activity and location) (Include ZIP Code)</i>	DATE
---	---	-------------

PART II – REPAIR PARTS AND SPECIAL TOOL LISTS AND SUPPLY CATALOGS/SUPPLY MANUALS

PUBLICATION/FORM NUMBER TM 9-2320-272-1	DATE 10 September 2012	TITLE Truck, 5-Ton, 6X6, M939A1, And M939A2 Series Trucks (Diesel), Field Maintenance Manual
---	----------------------------------	--

PAGE NO.	COLM NO.	LINE NO.	NATIONAL STOCK NUMBER	REFERENCE NO.	FIGURE NO.	ITEM NO.	TOTAL NO. OF MAJOR ITEMS SUPPORTED	RECOMMENDED ACTION

PART III – REMARKS *(Any general remark, or recommendations, or suggestions for improvement of publications and blank forms. Additional blank sheets may be used if more space is needed.)*

TYPED NAME, GRADE OR TITLE	TELEPHONE EXCHANGE/AUTOVON, PLUS EXTENSION	SIGNATURE
----------------------------	--	-----------

RECOMMENDED CHANGES TO PUBLICATIONS AND BLANK FORMS						Use Part II (reverse) for Repair Parts and Special Tool Lists (RPSTL) and Supply Catalogs/Supply Manuals (SC/SM).	DATE
For use of this form, see AR 25-30; the proponent agency is OAASA							
TO (Forward to proponent of publication or form) (Include ZIP Code) U.S. Army TACOM Life Cycle Management Command ATTN: AMSTA-LCL-MPP/TECH PUBS 6501 E. 11 Mile Road, Warren, MI 48397-5000						FROM (Activity and location) (Include ZIP Code)	
PART I – ALL PUBLICATIONS (EXCEPT RPSTL AND SC/SM) AND BLANK FORMS							
PUBLICATION/FORM NUMBER TM 9-2320-272-1						DATE 10 September 2012	TITLE Truck, 5-Ton, 6X6, M939A1, And M939A2 Series Trucks (Diesel), Field Maintenance Manual
ITEM	PAGE	PARA-GRAPH	LINE	FIGURE NO.	TABLE	RECOMMENDED CHANGES AND REASON	
TYPED NAME, GRADE OR TITLE					TELEPHONE EXCHANGE/AUTOVON, PLUS EXTENSION		SIGNATURE

TO <i>(Forward direct to addressee listed in publication)</i> U.S. Army TACOM Life Cycle Management Command ATTN: AMSTA-LCL-MPP/TECH PUBS 6501 E. 11 Mile Road, Warren, MI 48397-5000	FROM <i>(Activity and location) (Include ZIP Code)</i>	DATE
---	---	-------------

PART II – REPAIR PARTS AND SPECIAL TOOL LISTS AND SUPPLY CATALOGS/SUPPLY MANUALS

PUBLICATION/FORM NUMBER TM 9-2320-272-1	DATE 10 September 2012	TITLE Truck, 5-Ton, 6X6, M939A1, And M939A2 Series Trucks (Diesel), Field Maintenance Manual
---	----------------------------------	--

PAGE NO.	COLM NO.	LINE NO.	NATIONAL STOCK NUMBER	REFERENCE NO.	FIGURE NO.	ITEM NO.	TOTAL NO. OF MAJOR ITEMS SUPPORTED	RECOMMENDED ACTION

PART III – REMARKS *(Any general remarks, recommendations, or suggestions for improvement of publications and blank forms. Additional blank sheets may be used if more space is needed.)*

TYPED NAME, GRADE OR TITLE	TELEPHONE EXCHANGE/AUTOVON, PLUS EXTENSION	SIGNATURE
----------------------------	--	-----------

RECOMMENDED CHANGES TO PUBLICATIONS AND BLANK FORMS						Use Part II (reverse) for Repair Parts and Special Tool Lists (RPSTL) and Supply Catalogs/Supply Manuals (SC/SM).	DATE
For use of this form, see AR 25-30; the proponent agency is OAASA							
TO (Forward to proponent of publication or form) (Include ZIP Code) U.S. Army TACOM Life Cycle Management Command ATTN: AMSTA-LCL-MPP/TECH PUBS 6501 E. 11 Mile Road, Warren, MI 48397-5000						FROM (Activity and location) (Include ZIP Code)	
PART I – ALL PUBLICATIONS (EXCEPT RPSTL AND SC/SM) AND BLANK FORMS							
PUBLICATION/FORM NUMBER TM 9-2320-272-1						DATE 10 September 2012	TITLE Truck, 5-Ton, 6X6, M939A1, And M939A2 Series Trucks (Diesel), Field Maintenance Manual
ITEM	PAGE	PARA-GRAPH	LINE	FIGURE NO.	TABLE	RECOMMENDED CHANGES AND REASON	
TYPED NAME, GRADE OR TITLE					TELEPHONE EXCHANGE/AUTOVON, PLUS EXTENSION		SIGNATURE

TO <i>(Forward direct to addressee listed in publication)</i> U.S. Army TACOM Life Cycle Management Command ATTN: AMSTA-LCL-MPP/TECH PUBS 6501 E. 11 Mile Road, Warren, MI 48397-5000	FROM <i>(Activity and location) (Include ZIP Code)</i>	DATE
---	---	-------------

PART II – REPAIR PARTS AND SPECIAL TOOL LISTS AND SUPPLY CATALOGS/SUPPLY MANUALS

PUBLICATION/FORM NUMBER TM 9-2320-272-1	DATE 10 September 2012	TITLE Truck, 5-Ton, 6X6, M939A1, And M939A2 Series Trucks (Diesel), Field Maintenance Manual
---	----------------------------------	--

PAGE NO.	COLM NO.	LINE NO.	NATIONAL STOCK NUMBER	REFERENCE NO.	FIGURE NO.	ITEM NO.	TOTAL NO. OF MAJOR ITEMS SUPPORTED	RECOMMENDED ACTION

PART III – REMARKS *(Any general remarks, recommendations, or suggestions for improvement of publications and blank forms. Additional blank sheets may be used if more space is needed.)*

TYPED NAME, GRADE OR TITLE	TELEPHONE EXCHANGE/AUTOVON, PLUS EXTENSION	SIGNATURE
----------------------------	--	-----------

By Order of the Secretary of the Army:

Official:



JOYCE E. MORROW
*Administrative Assistant to the
Secretary of the Army*

1220207

RAYMOND T. ODIERNO
*General, United States Army
Chief of Staff*

By Order of the Secretary of the Air Force:

DONALD J. HOFFMAN
*General, United States Air Force
Commander, AFMC*

NORTON A. SCHWARTZ
*General, United States Air Force
Chief of Staff*

Distribution:

To be distributed in accordance with the initial distribution number (IDN) 386968 requirements for TM 9-2320-272-23-1 .

THE METRIC SYSTEM AND EQUIVALENTS

LINEAR MEASURE

1 Centimeter=10 Millimeters=0.01 Meters=0.3937 Inches
 1 Meter=100 Centimeters=1000 Millimeters=39.37 Inches
 1 Kilometer=1000 Meters=0.621 Miles

WEIGHTS

1 Gram=0.001 Kilograms=1000 Milligrams=0.035 Ounces
 1 Kilogram=1000 Grams=2.2 Lb
 1 Metric Ton=1000 Kilograms=1 Megagram=1.1 Short Tons

LIQUID MEASURE

1 Milliliter=0.001 Liters=0.0338 Fluid Ounces
 1 Liter=1000 Milliliters=33.82 Fluid Ounces

SQUARE MEASURE

1 Sq Centimeter=100 Sq Millimeters=0.155 Sq Inches
 1 Sq Meter=10,000 Sq Centimeters=10.76 Sq Feet
 1 Sq Kilometer=1,000,000 Sq Meters=0.386 Sq Miles

CUBIC MEASURE

1 Cu Centimeter=1000 Cu Millimeters=0.06 Cu Inches
 1 Cu Meter=1,000,000 Cu Centimeters=35.31 Cu Feet

TEMPERATURE

$5/9 (^{\circ}\text{F} - 32) = ^{\circ}\text{C}$
 212°Fahrenheit is equivalent to 100°Celsius
 90°Fahrenheit is equivalent to 32.2°Celsius
 32°Fahrenheit is equivalent to 0°Celsius
 $9/5 (^{\circ}\text{C} + 32) = ^{\circ}\text{F}$

APPROXIMATE CONVERSION FACTORS

<u>TO CHANGE</u>	<u>TO</u>	<u>MULTIPLY BY</u>
Inches	Centimeters	2.540
Feet	Meters	0.305
Yards	Meters	0.914
Miles	Kilometers	1.609
Square Inches	Square Centimeters	6.451
Square Feet	Square Meters	0.093
Square Yards	Square Meters	0.836
Square Miles	Square Kilometers	2.590
Acres	Square Hectometers	0.405
Cubic Feet	Cubic Meters	0.028
Cubic Yards	Cubic Meters	0.765
Fluid Ounces	Milliliters	29.573
Pints	Liters	0.473
Quarts	Liters	0.946
Gallons	Liters	3.785
Ounces	Grams	28.349
Pounds	Kilograms	0.454
Short Tons	Metric Tons	0.907
Pound-Feet	Newton-Meters	1.356
Pounds/Sq Inch	Kilopascals	6.895
Miles per Gallon	Kilometers per Liter	0.425
Miles per Hour	Kilometers per Hour	1.609

<u>TO CHANGE</u>	<u>TO</u>	<u>MULTIPLY BY</u>
Centimeters	Inches	0.394
Meters	Feet	3.280
Meters	Yards	1.094
Kilometers	Miles	0.621
Sq Centimeters	Square Inches	0.155
Square Meters	Square Feet	10.764
Square Meters	Square Yards	1.196
Square Kilometers	Square Miles	0.386
Sq Hectometers	Acres	2.471
Cubic Meters	Cubic Feet	35.315
Cubic Meters	Cubic Yards	1.308
Milliliters	Fluid Ounces	0.034
Liters	Pints	2.113
Liters	Quarts	1.057
Liters	Gallons	0.264
Grams	Ounces	0.035
Kilograms	Pounds	2.205
Metric Tons	Short Tons	1.102
Newton-Meters	Pound-Feet	0.738
Kilopascals	Pounds per Sq Inch	0.145
Km per Liter	Miles per Gallon	2.354
Km per Hour	Miles per Hour	0.621

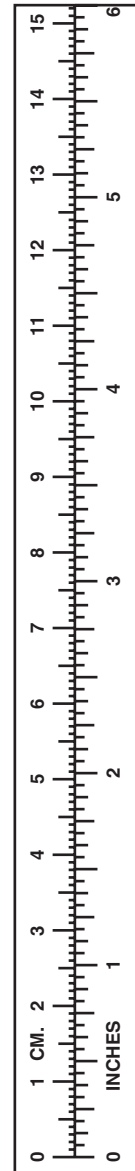

PIN: 087175-000