

Service Manual

Stereo Integrated Amplifier

Amplifier

SU-810

Color

(S) Silver Type
(K) Black Type

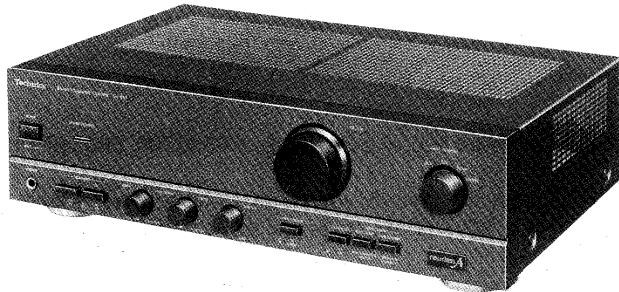

Area

Country Code	Area	Color
(E)	Continental Europe	(K) (S)
(E5)	Continental Europe	(K)
(EB)	Great Britain	(K)
(EG)	F.R. Germany & Italy	(K) (S)

SPECIFICATIONS (DIN 45 500)

20 Hz~20 kHz continuous power output both channels driven	2 × 40 W (8 Ω)
1 kHz continuous power output both channels driven (THD: 1%)	2 × 50 W (8 Ω) 2 × 75 W (4 Ω)
63 Hz~12.5 kHz continuous power output both channels driven (0.7%)	2 × 45 W (8 Ω) 2 × 65 W (4 Ω)
Total harmonic distortion	
rated power at 20 Hz~20 kHz	0.02% (8 Ω)
rated power at 1 kHz	0.007% (8 Ω)
half power at 20 Hz~20 kHz	0.02% (8 Ω)
half power at 1 kHz	0.007% (8 Ω)
Intermodulation distortion	
rated power at 50 Hz: 7 kHz = 4:1, SMPTE, 8 Ω	0.02%
Residual hum and noise	1 mV
Damping factor	60 (8 Ω), 30(4 Ω)
Headphones output level and impedance	450 mV/330 Ω
Load impedance	
A or B	4 Ω~16 Ω
A and B	8 Ω~16 Ω
Input sensitivity and impedance	
PHONO	2.5 mV/47 kΩ
TUNER, CD, AUX, TAPE 1/DAT, TAPE 2/ADAPT	150 mV/22 kΩ
Phono maximum input voltage (IHF '66, 1 kHz, RMS)	150 mV
S/N	
rated power (4 Ω)	
PHONO	76 dB (IHF '66: 79 dB)
TUNER, CD, AUX, TAPE 1/DAT, TAPE 2/ADAPT	91 dB (IHF '66: 99 dB)
-26 dB power (4 Ω)	
PHONO	68 dB
TUNER, CD, AUX, TAPE 1/DAT, TAPE 2/ADAPT	70 dB
50 mW power (4 Ω)	
PHONO	64 dB
TUNER, CD, AUX, TAPE 1/DAT, TAPE 2/ADAPT	64 dB

Frequency response

PHONO	RIAA standard curve ±1 dB (30 Hz~15 kHz)
TUNER, CD, AUX, TAPE 1/DAT, TAPE 2/ADAPT	3 Hz~80 kHz (-3 dB) +0 dB, -0.3 dB (20 Hz~20 kHz)

Tone controls

BASS	50 Hz, +10 dB, -10 dB
TREBLE	20 kHz, +10 dB, -10 dB
Loudness control (volume at -30 dB)	50 Hz, +9 dB

Output voltage

TAPE 1/DAT, TAPE 2/ADAPT REC OUT	150 mV
Channel balance, AUX 250 Hz~6,300 Hz	±1 dB
Channel separation, AUX 1 kHz	50 dB

■ GENERAL

Power consumption	380 W
Power supply	
For Great Britain	AC 50 Hz/60 Hz, 240 V
For Continental Europe, F.R. Germany & Italy	AC 50 Hz/60 Hz, 220 V
Dimensions (W × H × D)	430 × 125 × 320 mm (16-15/16" × 4-15/16" × 12-5/8")
Weight	6.8 kg (15 lb.)

Notes:

- Specifications are subject to change without notice.
Weight and dimensions are approximate.
- Total harmonic distortion is measured by the digital spectrum analyzer.

Technics

Matsushita Electric Industrial Co., Ltd.
Central P.O. Box 288, Osaka 530-91, Japan

■ CONTENTS

	Page		Page
BEFORE REPAIR	2	SCHEMATIC DIAGRAM	10~12
PROTECTION CIRCUITRY	2	PRINTED CIRCUIT BOARDS AND	
ACCESSORY	2	WIRING CONNECTION DIAGRAM	13~15
LOCATION OF CONTROLS	3	TERMINAL GUIDE OF IC'S,	
CONNECTIONS	4, 5	TRANSISTORS AND DIODES	16
DISASSEMBLY INSTRUCTIONS	6~8	REPLACEMENT PARTS LIST	17, 18, 21
BLOCK DIAGRAM	9	EXPLODED VIEW	19, 20

■ BEFORE REPAIR

- (1) Turn off the power supply. Using a 10Ω, 5 W resistor connect both ends of power supply capacitors (C705, C706, 6800 μF) in order to discharge the voltage.
- (2) Before turning the power supply on, after completion of repair, slowly apply the primary voltage by using a power supply voltage controller to make sure that the consumed current at 50 Hz/60 Hz in NO SIGNAL mode should be shown below with respect to supply voltage 220 V/240 V.

Power supply voltage	AC 220 V	AC 240 V
Consumed current 50 Hz	60~240 mA	55~220 mA
Consumed current 60 Hz	56~227 mA	52~208 mA

■ PROTECTION CIRCUITRY

The protection circuitry may have operated if either of the following conditions is noticed:

*No sound is heard when the power is switched ON.

*Sound stops during a performance.

The function of this circuitry is to prevent circuitry damage if, for example, the positive and negative speaker connection wires are "shorted", or if speaker systems with an impedance less than the indicated rated impedance of this unit are used.

If this occurs, follow the procedure outlined below:

1. Switch OFF the power.
2. Determine the cause of the problem and correct it.
3. Switch ON the power once again.

Note:

When the protection circuitry functions, the unit will not operate unless the power is first switched OFF and then ON again.

■ ACCESSORY

- AC power supply cord 1
Configuration of AC power supply cord differs according to area.

SJA193 (1.5 m) For (EB) area only.

SFDAC05E03 (1.5 m) For others.

■ LOCATION OF CONTROLS

●Front Panel

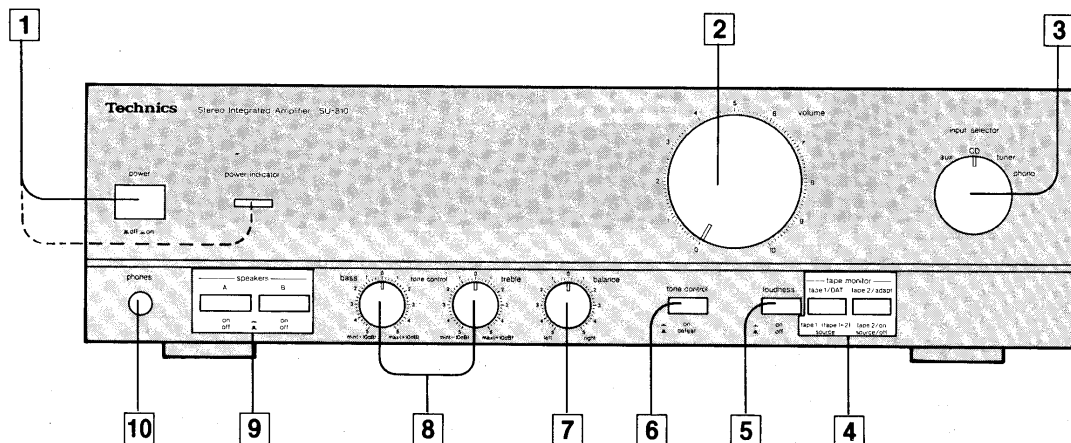

1 Power switch/indicator (power)

2 Volume control (volume)

3 Input selector (input selector)

This selector is used to select the sound source to be heard, such as a disc, radio broadcast, etc.

4 Tape-monitor selectors (tape monitor)

The left selector is used to playback or monitor the sound from a tape deck 1 (or DAT) or to record from tape deck 1 (or DAT) to 2.

The right selector is used to playback or monitor the sound from a tape deck 2 or to listen to the sound processed by a graphic equalizer.

5 Loudness switch (loudness)

This switch is used when listening to music at a low volume level. Auditory perception of sound in the low frequency range falls off at low volume, but when the switch is set to the "on" position, this deficiency is compensated for, so that the full impact of the musical performance can be enjoyed.

6 Tone control switch (tone control)

This switch is used to turn the tone control circuit (bass, treble) on or off.

7 Balance control (balance)

This control is used to adjust the left/right volume balance.

8 Tone controls (bass/treble)

The bass control is used to adjust the low-frequency sound range, and the treble control is used to adjust the high-frequency sound range.

9 Speaker selectors (speakers)

These selectors are used to turn the speaker systems on and off.

10 Headphones jack (phones)

●Rear Panel

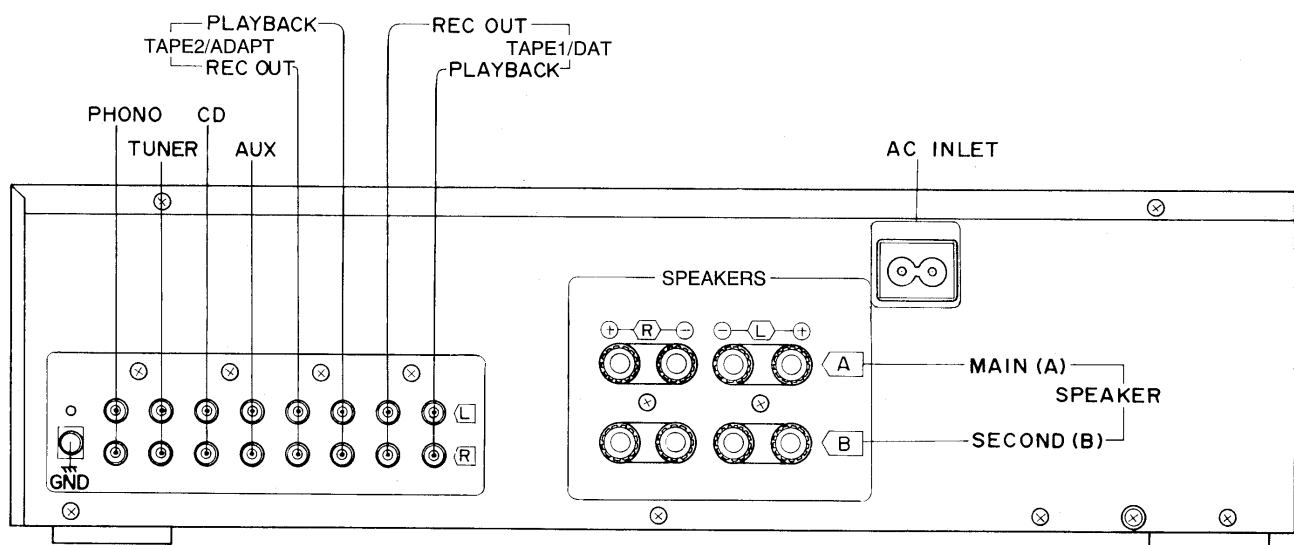

*Phono input capacitance is about 270 pF.

CONNECTIONS

System configurations

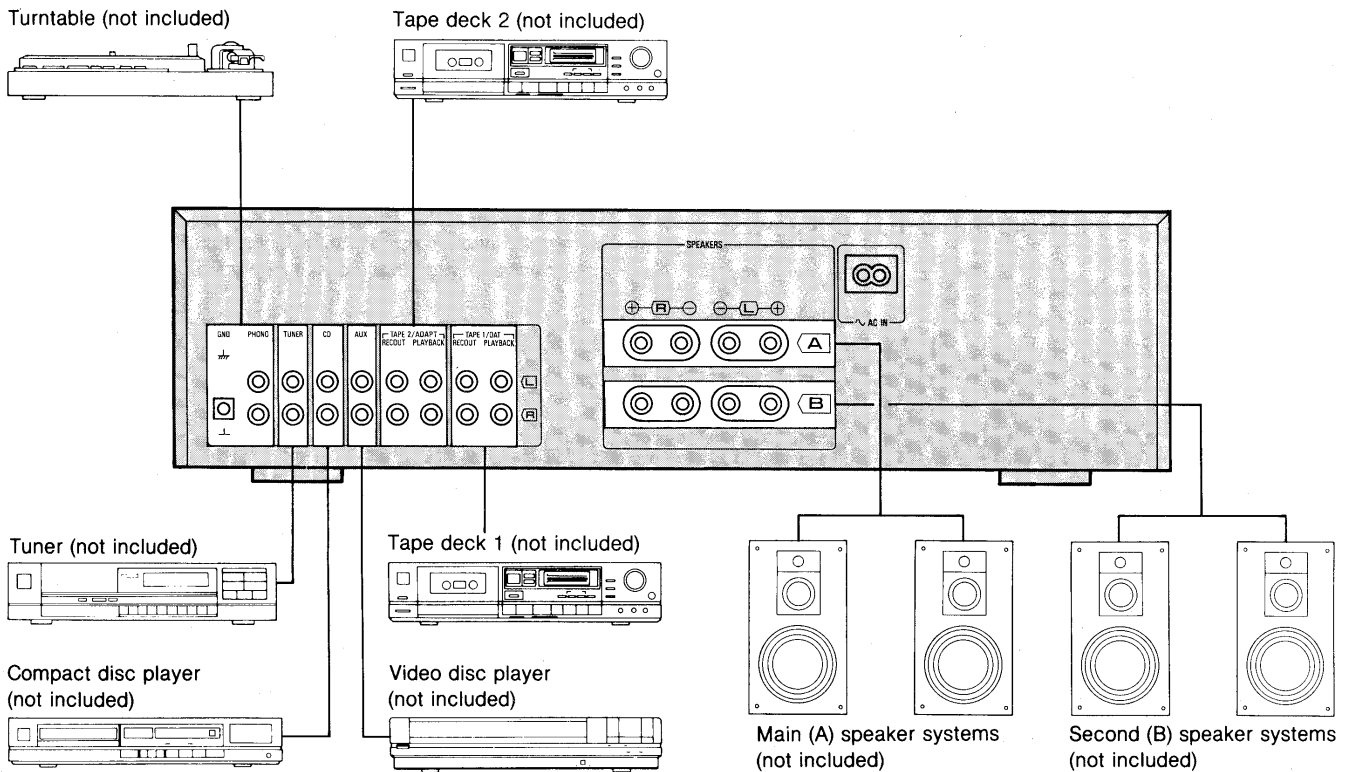

To connect to each terminals

Make connections to each component in the system by using stereo connection cables (not included).

“PHONO” terminals

Connect a turntable.

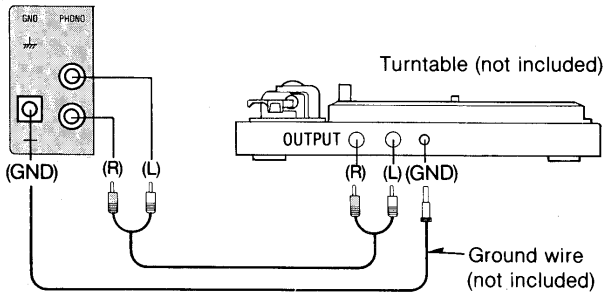

“CD” terminals

Connect a compact disc player.

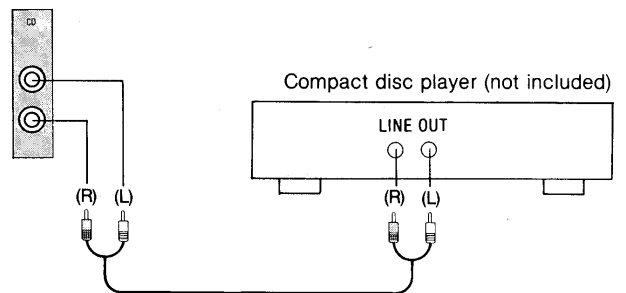

“TUNER” terminals

Connect a tuner.

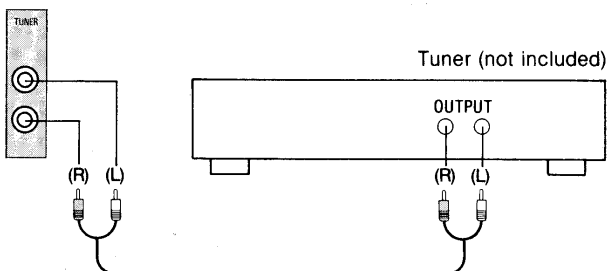

“AUX” terminals

Connect a component such as a video disc player (audio only connectable), etc.

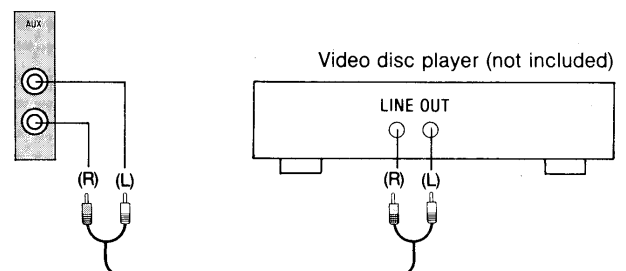

"TAPE 2/ADAPT" terminals

Connect a second tape deck or a graphic equalizer.

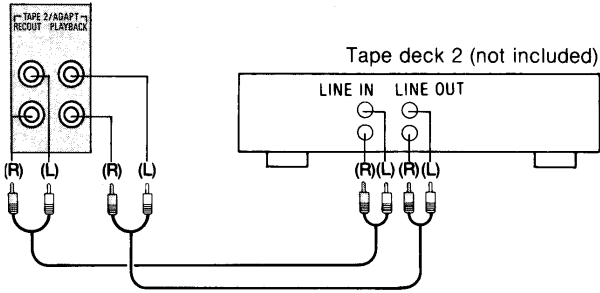

"TAPE 1/DAT" terminals

Connect a first tape deck or a digital audio tape deck (DAT).

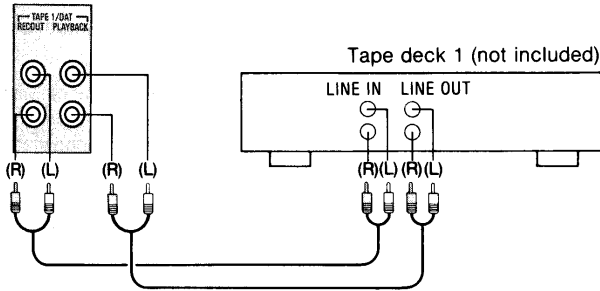

To connect the AC power supply cord (included)

Connect the AC power supply cord (included) after all other cables and cords are connected.

Note: Configuration of AC power supply cord differs according to area.

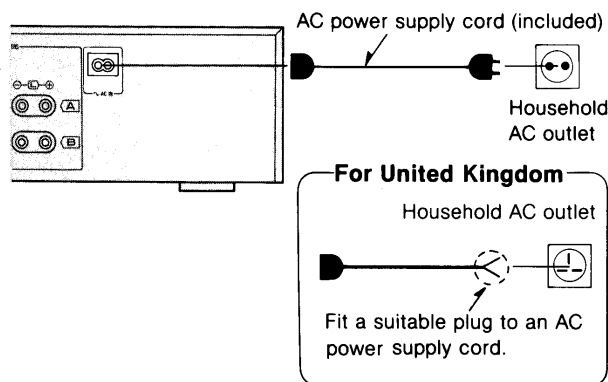

Connection to speaker systems

One pair of speaker systems can be connected to the "A" terminals of this unit and one pair to the "B" terminals.

Load impedance

- When only the "A" or only the "B" terminals are used: 4-16 ohms
- When both the "A" and the "B" terminals are used simultaneously: 8-16 ohms

To connect main (A) and/or second (B) speaker systems

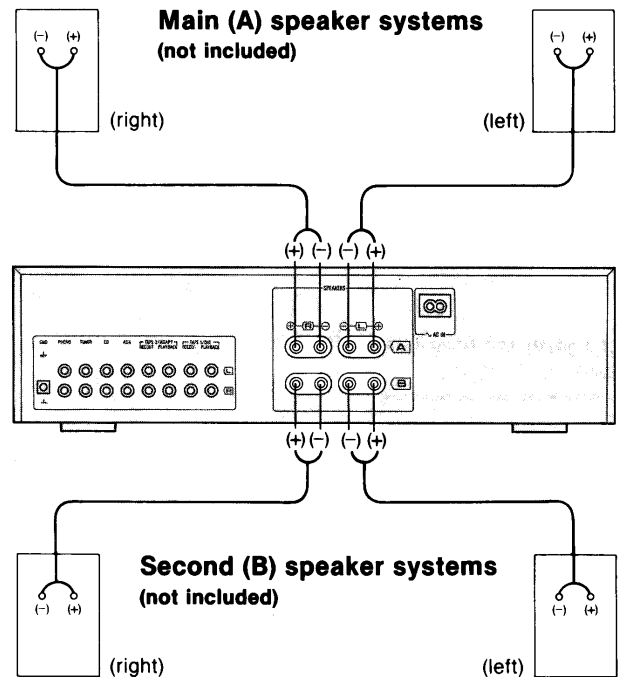

To connect cords to terminals

- ① Strip off the outer covering, and twist the center conductor. 10 mm (13/32") Twist.

- ② Turn 5 or 6 times.

- ③ Insert the wire and tighten screw completely. Pull the wire to assure a proper connection.

Note: Be sure to only connect positive (+) cords to positive (+) terminals, and negative (-) cords to negative (-) terminals.

Note: To prevent damage to circuitry, never short-circuit the plus (+) and minus (-) speaker terminals.

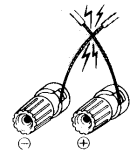

DISASSEMBLY INSTRUCTIONS

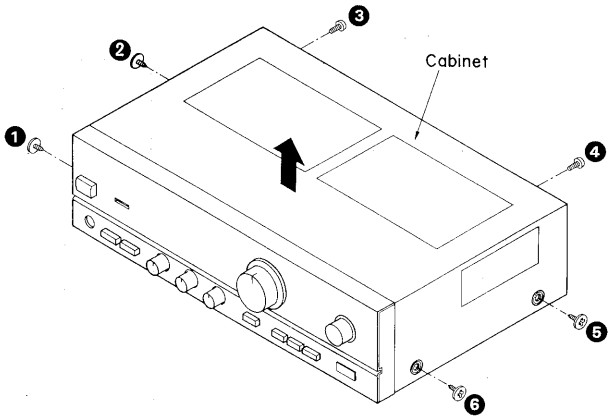
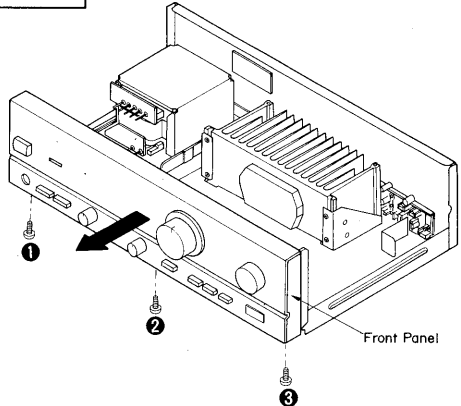
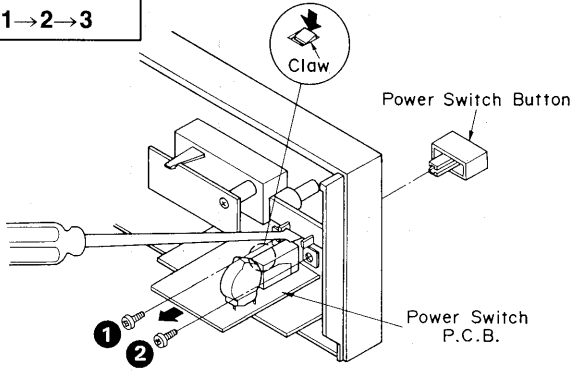
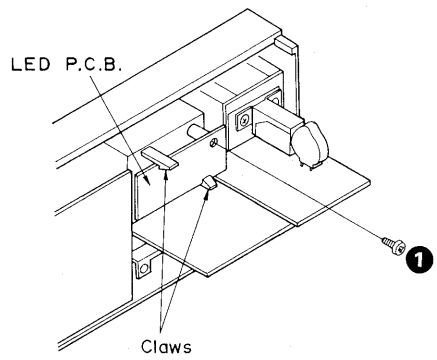
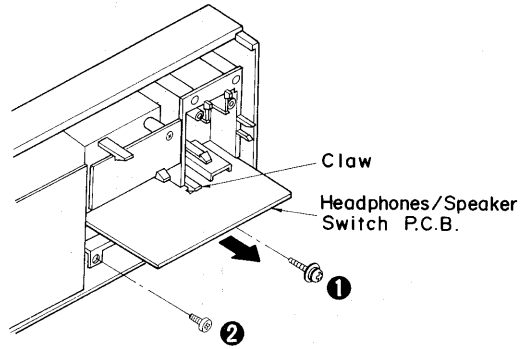
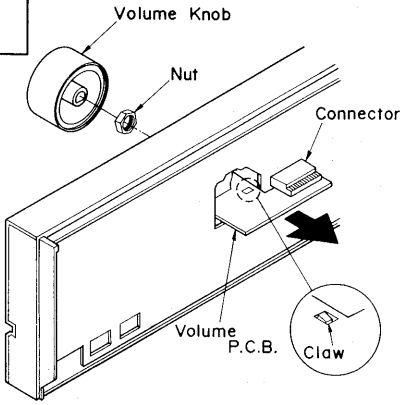
<p>Ref. No. 1</p>	<p>Removal of the cabinet</p>	<p>Ref. No. 2</p>	<p>Removal of the front panel</p>
<p>Procedure 1</p>		<p>Procedure 1→2</p>	
 <p>●Remove the 6 screws (①~⑥).</p>		 <ol style="list-style-type: none"> 1. Remove the 3 screws (①~③). 2. Remove the front panel in the direction of the arrow. 	
<p>Ref. No. 3</p>	<p>Removal of the power switch P.C.B.</p>	<p>Ref. No. 4</p>	<p>Removal of the LED P.C.B.</p>
<p>Procedure 1→2→3</p>		<p>Procedure 1→2→4</p>	
 <ol style="list-style-type: none"> 1. Remove the power switch button by pushing it from behind the front panel. 2. Remove the 2 screws (①, ②). 3. Release the 1 claw. 		 <ol style="list-style-type: none"> 1. Remove the 1 screw (①). 2. Release the 2 claws. 	
<p>Ref. No. 5</p>	<p>Removal of the headphones/speaker switch P.C.B.</p>	<p>Ref. No. 6</p>	<p>Removal of the volume P.C.B.</p>
<p>Procedure 1→2→3→5</p>		<p>Procedure 1→2→6</p>	
 <ol style="list-style-type: none"> 1. Remove the 2 screws (①, ②). 2. Release the 1 claw. 		 <ol style="list-style-type: none"> 1. Pull out the volume knob. 2. Remove the nut. 3. Release the 1 claw. 	

Ref. No.
7

Removal of the operation P.C.B.

Procedure
1→2→6→7

1. Pull out the 4 knobs (1~4).
2. Remove the 4 nuts (5~8).
3. Remove the 4 screws (9~13).

●Use a wrench of the dimensions shown in the illustration above to remove nuts.

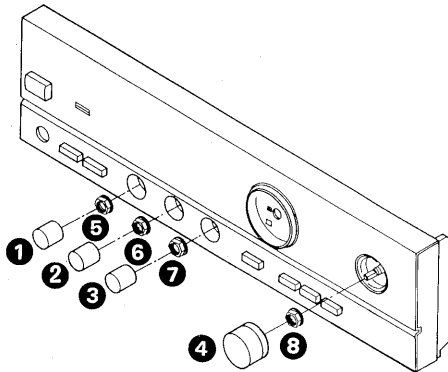
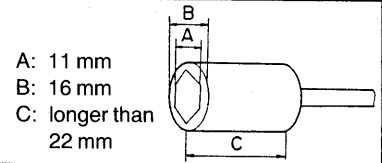

Operation P.C.B.

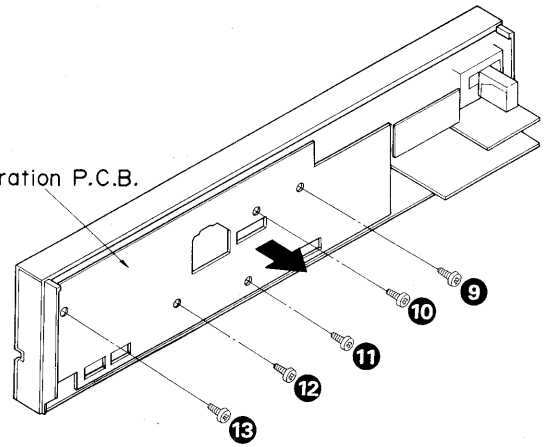

Ref. No.
8

Checking of the main P.C.B.

Procedure
1→8

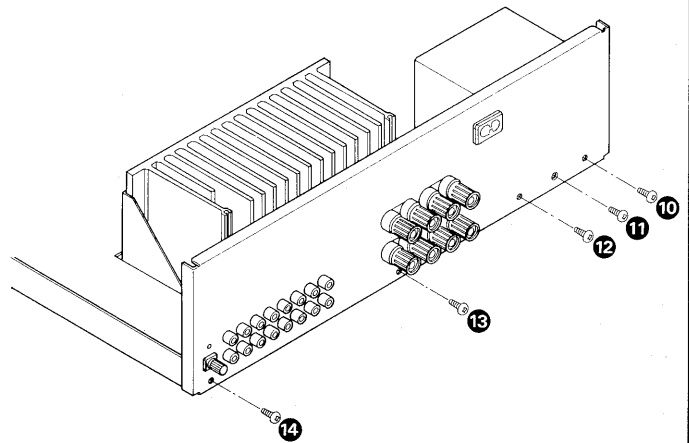
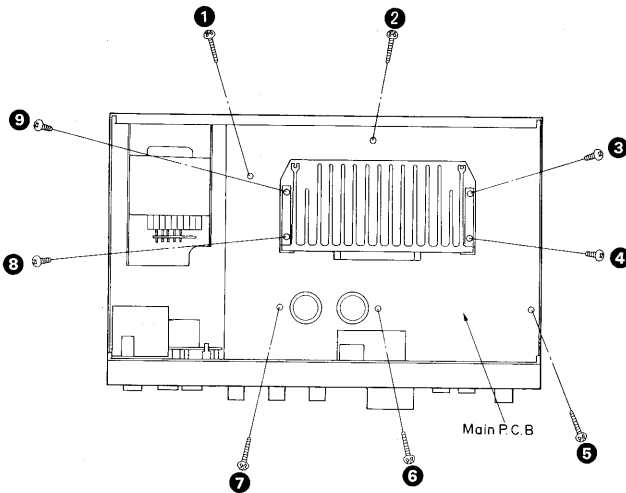

1. Remove the 9 screws (1~9).

2. Remove the 5 screws (10~14).

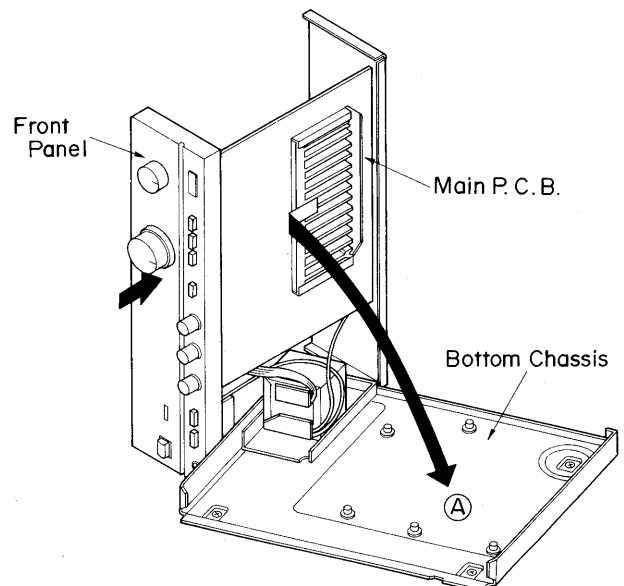
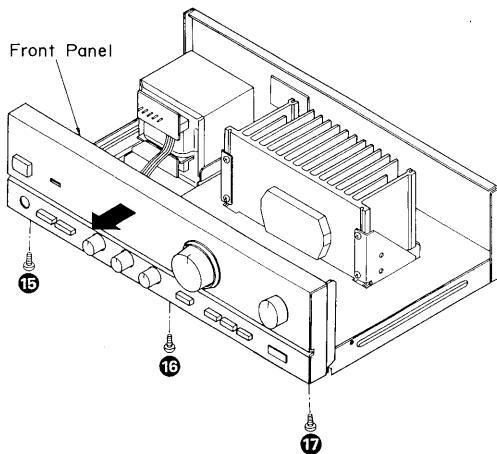

3. Remove the 3 screws (15~17).
4. Remove the front panel.

5. Remove the bottom chassis in the direction of the arrow (A).
6. Reinstall the front panel to the main P.C.B.

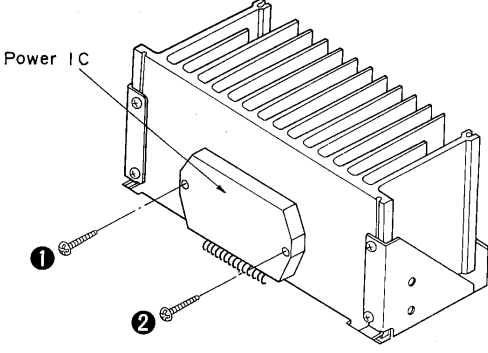
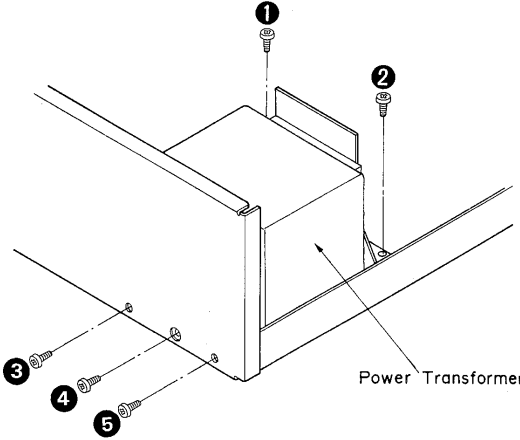
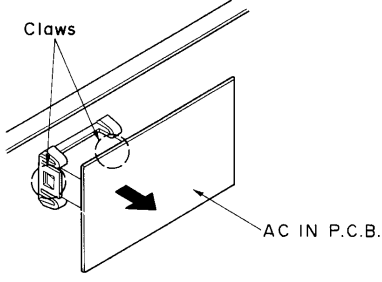
<p>Ref. No. 9</p>	<p>Removal of the power IC</p>	<p>Ref. No. 10</p>	<p>Removal of the power transformer</p>
<p>Procedure 1→8→9</p>			<p>Procedure 1→10</p>
 <p>1. Unsolder the power IC. 2. Remove the 2 screws (1, 2).</p> <p>●When mounting the power IC, apply silicon thermal compound (SZZ0L15 or equivalent) to the rear of the power IC.</p>		 <p>●Remove the 5 screws (1~5).</p>	
<p>Ref. No. 11</p>	<p>Removal of the AC IN P.C.B.</p>		
<p>Procedure 1→11</p>	<p>●Release the 2 claws.</p>		
			

“ATTENTION SERVICER”
Some chassis components may have sharp edges. Be careful when disassembling and servicing.

●Replacement of the Foot.

1. Remove the 4 heat melted posts on the chassis with a pair of diagonal pliers or similar tool.
2. To mount the foot (RKA0009-1) on the chassis, melt the 4 posts with a soldering iron.

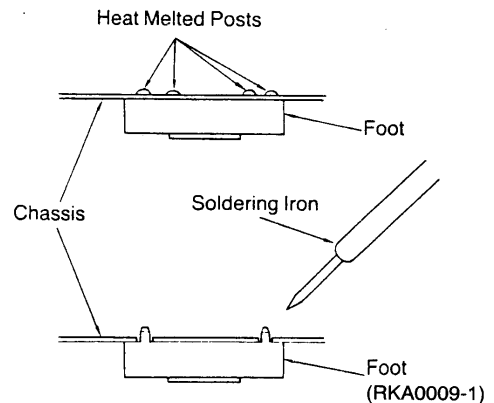

■ BLOCK DIAGRAM

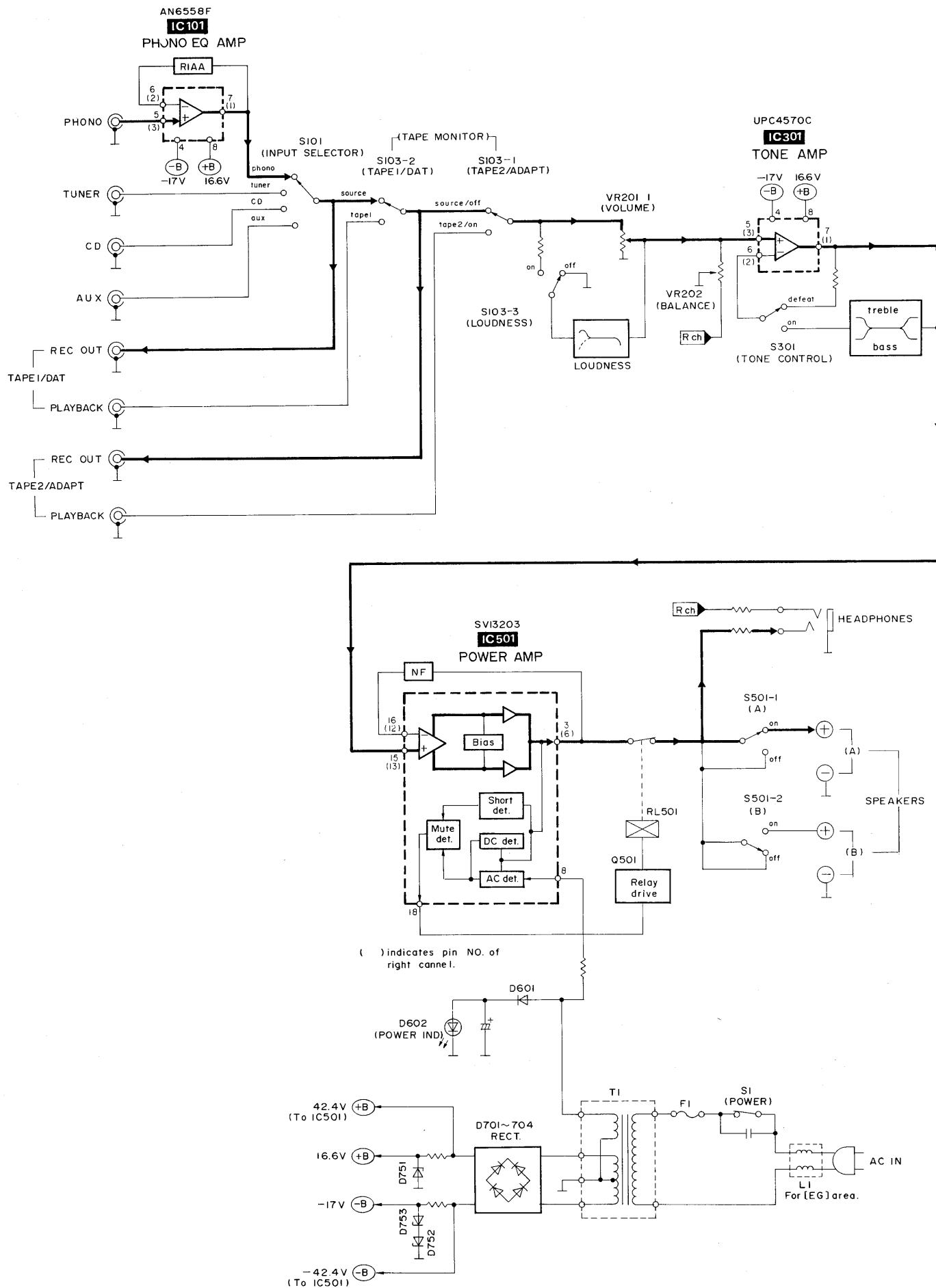

A INPUT SELECT / TONE AMP CIRCUIT

C VOLUME CIRCUIT

D LED CIRCUIT

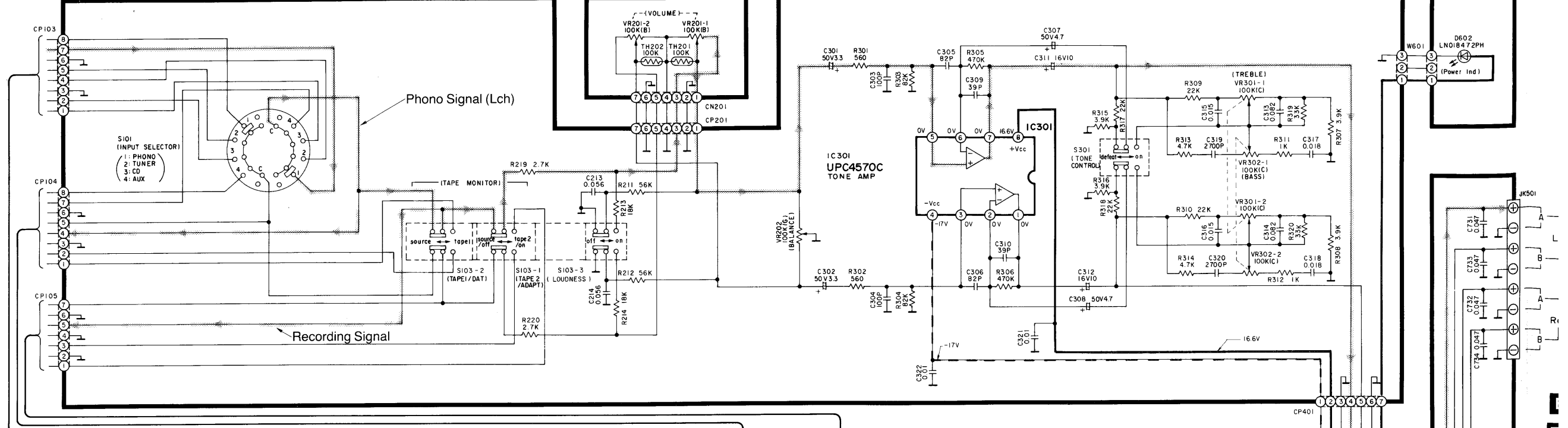

B MAIN CIRCUIT

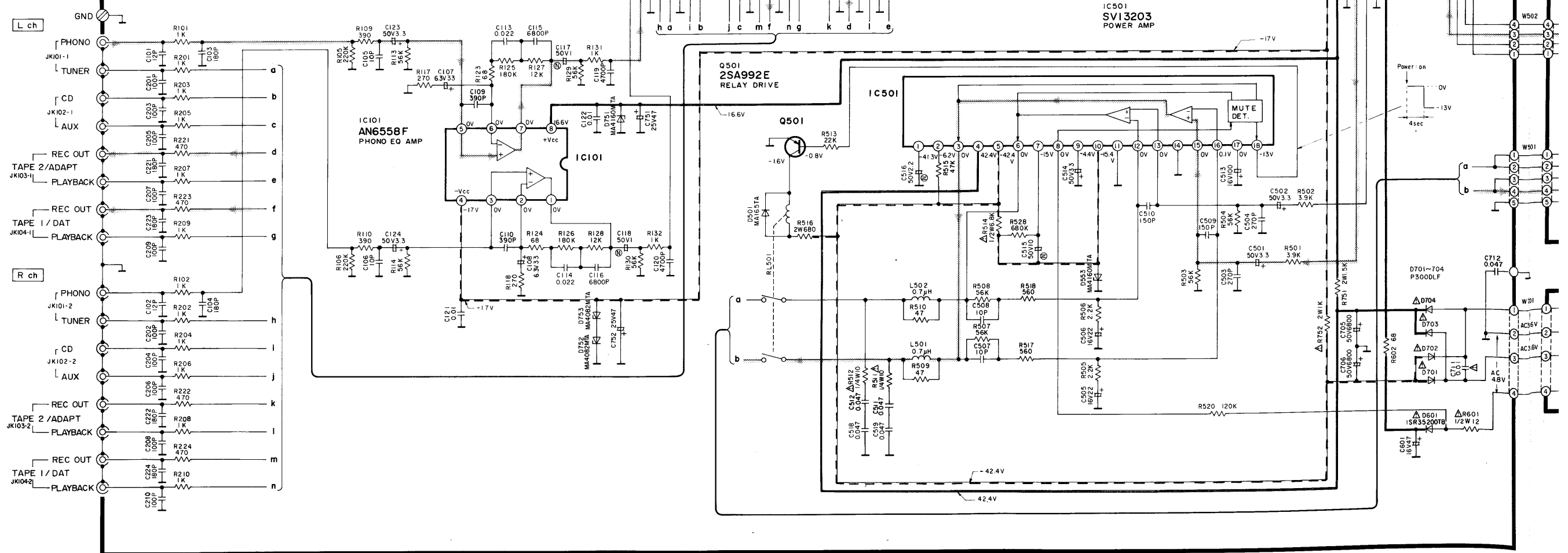

SCHEMATIC DIAGRAM

(Parts list on page 17, 18)

(This schematic diagram may be modified at any time with the development of new technology.)

Notes:

- S1 : Power switch in "on" position.
 - S101 : Input selector switch in "phono" position.
 - S103-1 : Tape-monitor select switch in "source/off" position. (tape 2/on-- source/off)
 - S103-2 : Tape-monitor select switch in "source" position. (tape 1/DAT-- source)
 - S103-3 : Loudness switch in "off" position.
 - S301 : Tone control switch in "defeat" position.
 - S501-1 : Speaker (A) switch in "on" position.
 - S501-2 : Speaker (B) switch in "off" position.
- : Positive voltage lines.
 - - - : Negative voltage lines.
 [Phono Signal (Lch)] : Phono Signal (Lch)
 [Recording Signal] : Recording Signal

•Indicated voltage values are the standard values for the unit measured by the DC electronic circuit tester (high-impedance) with the chassis taken as standard. Therefore, there may exist some errors in the voltage values, depending on the internal impedance of the DC circuit tester.

Important safety notice:

Components identified by Δ mark have special characteristics important for safety. When replacing any of these components, use only manufacturer's specified parts.

Caution!

- IC and LSI are sensitive to static electricity.
- Secondary trouble can be prevented by taking care during repair.
- *Cover the parts boxes made of plastics with aluminum foil.
- *Ground the soldering iron.
- *Put a conductive mat on the work table.
- *Do not touch the legs of IC or LSI with the fingers directly.

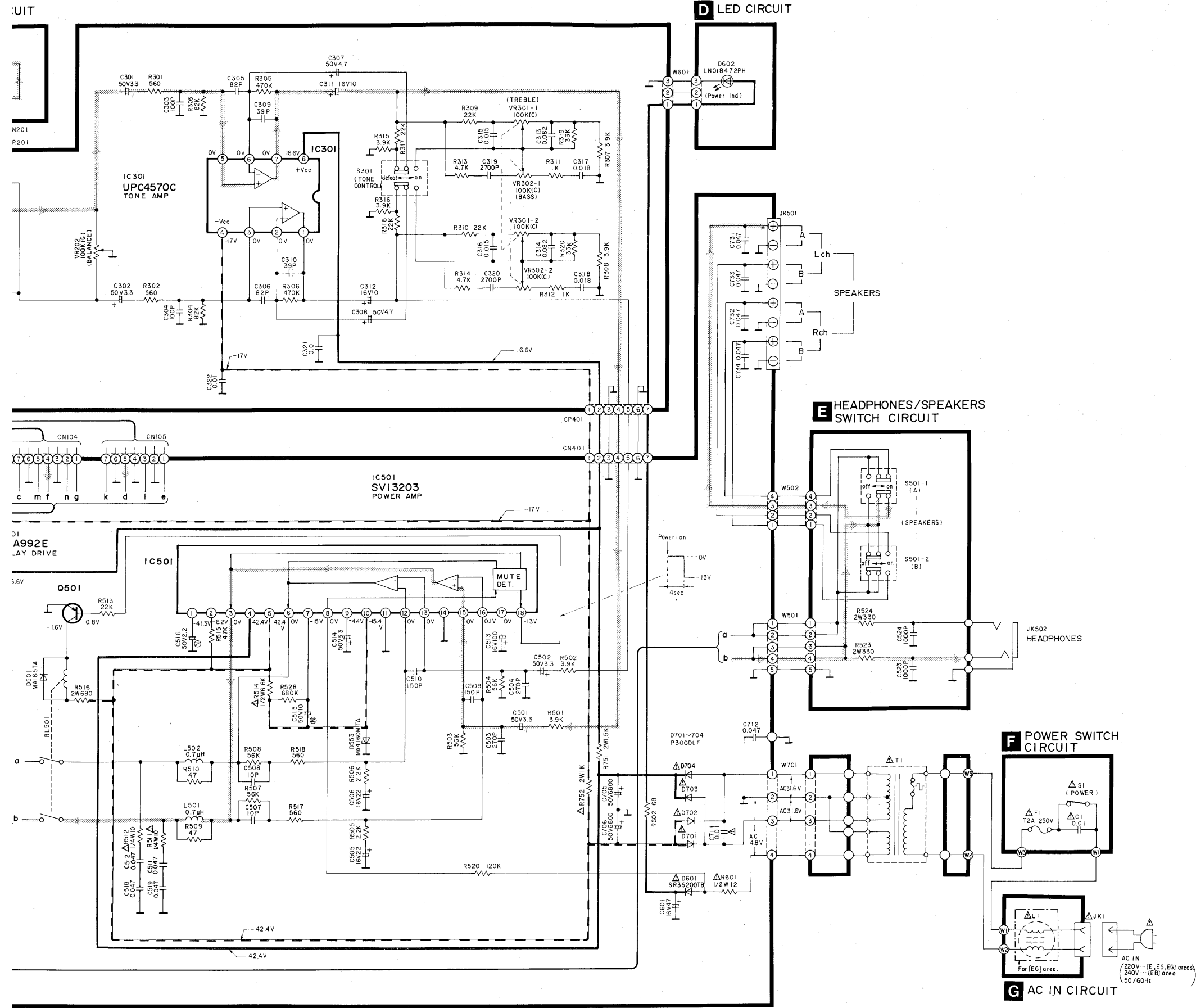

PRINTED CIRCUIT BOARDS AND WIRING CONNECTION DIAGRAM

(Parts list on page 17, 18)

A
B
C
D
E
F

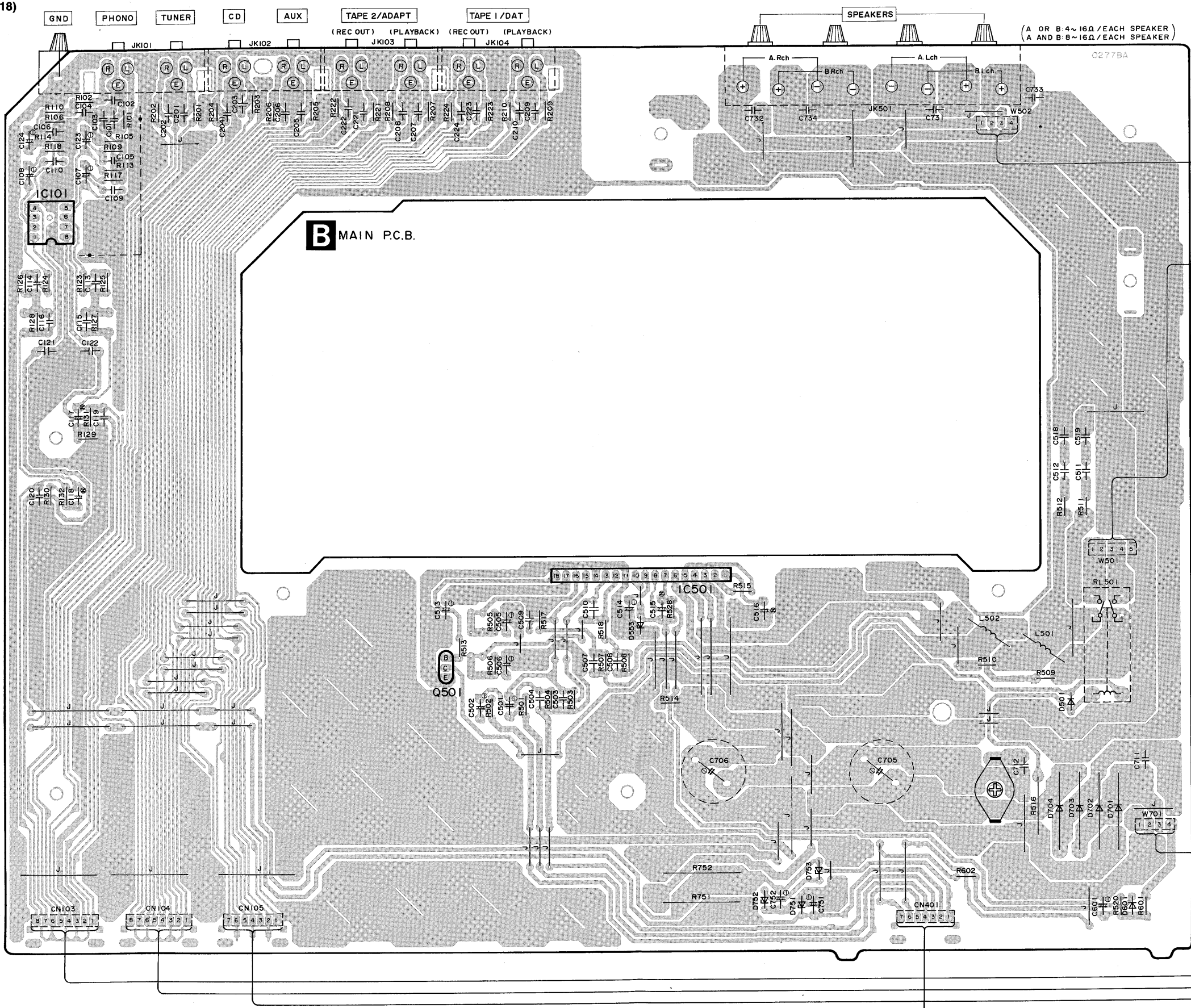

E HEADPHONES/SPEAKERS

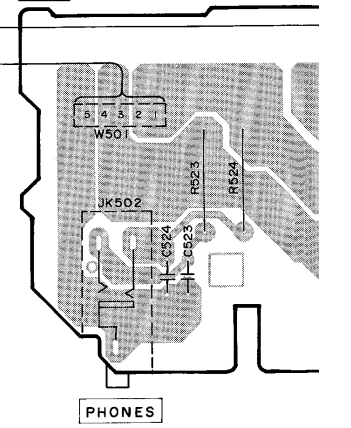

- 1...PHONO
- 2...TUNER
- 3...CD
- 4...AUX

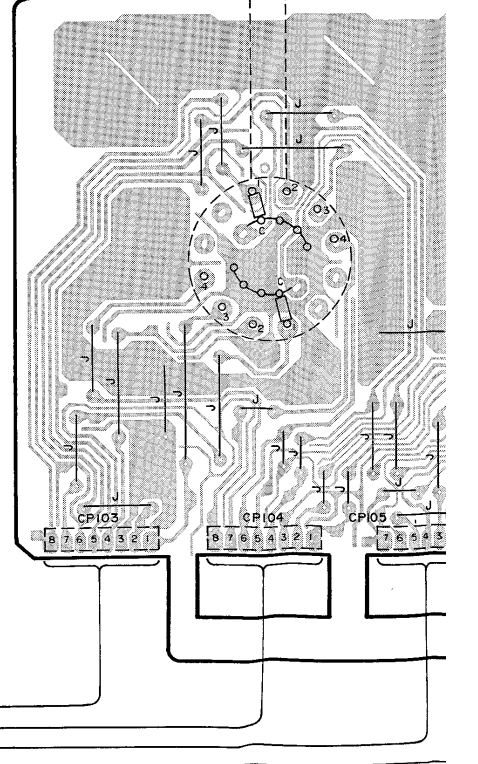

■ TERMINAL GUIDE OF IC'S, TRANSISTORS AND DIODES

<p>AN6558F UPC4570C</p>	<p>SVI3203</p>	<p>2SA992E</p>	<p>MA165TA 1SR35200TB</p>
<p>MA4082MTA</p>	<p>MA4160MTA</p>	<p>P300DLF</p>	<p>LN018472PH</p>

ES/SPEAKERS SWITCH P.C.B.

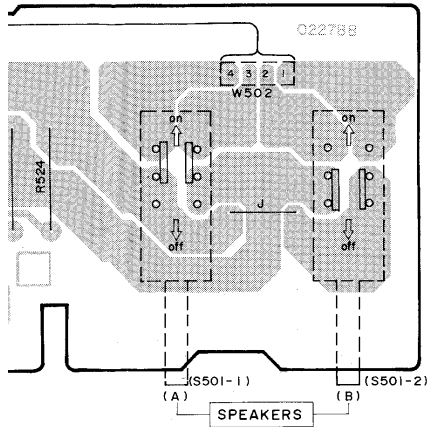

AC IN P.C.B.

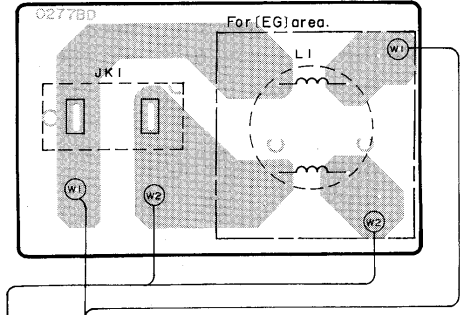

VOLUME P.C.B.

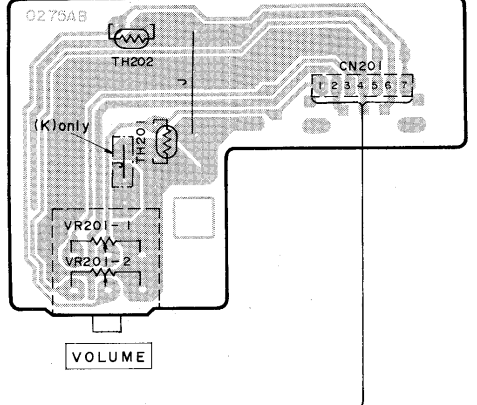

POWER SWITCH P.C.B.

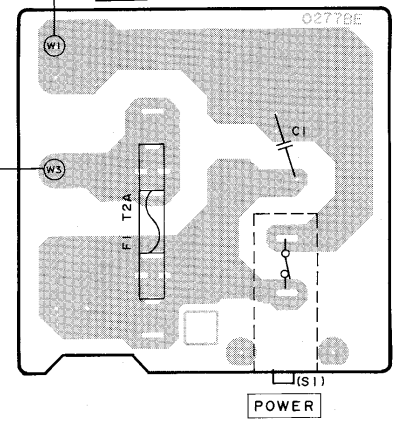

LED P.C.B.

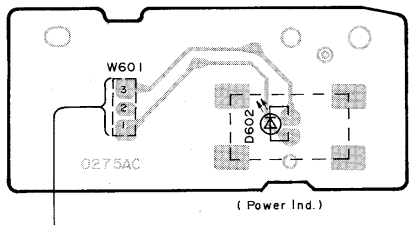

INPUT SELECT/TONE AMP P.C.B.

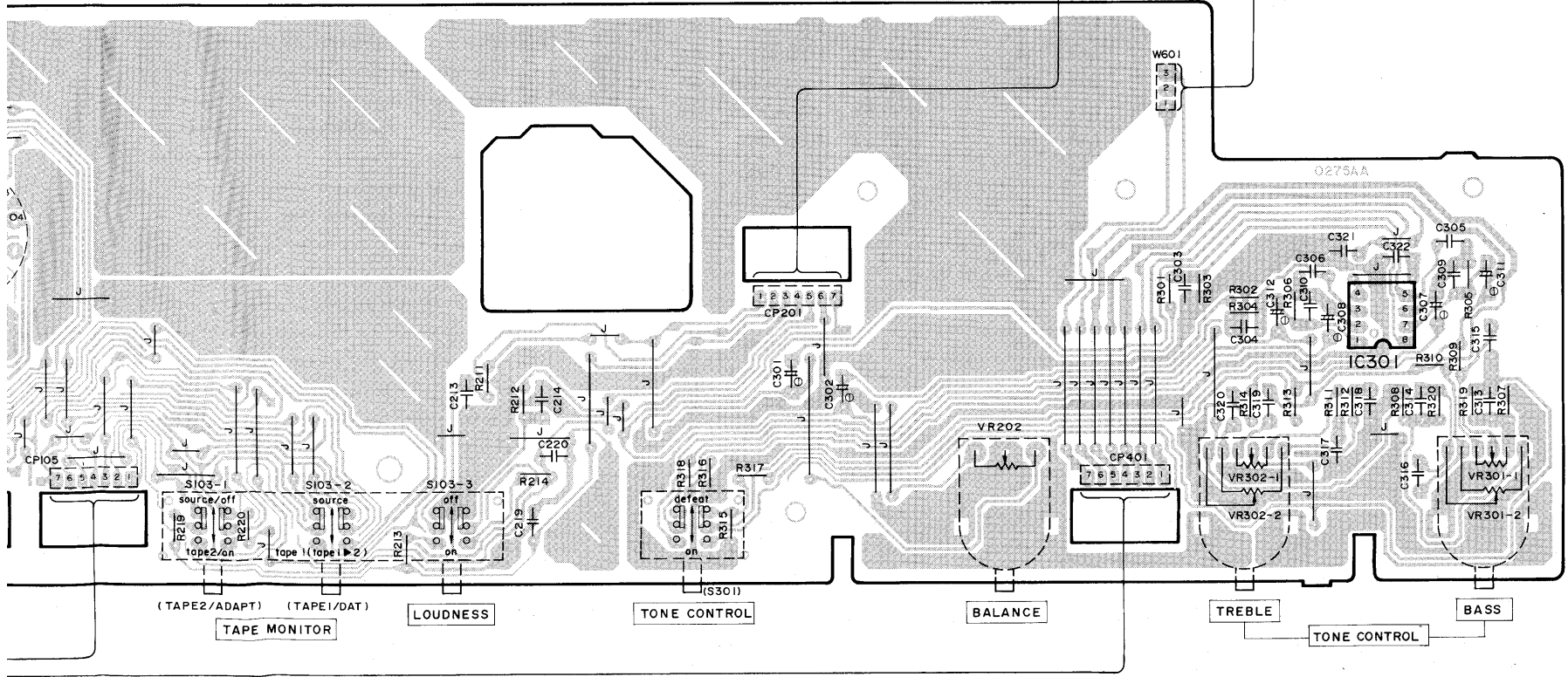

REPLACEMENT PARTS LIST

Notes: *Important safety notice:

Components identified by Δ mark have special characteristics important for safety. When replacing any of these components use only manufacturer's specified parts.

*The parenthesized indications in the Remarks columns specify the areas. (Refer to the first page for area.)

Parts without these indications can be used for all areas.

**"K" mark parts are used for black type only.

***"S" mark parts are used for silver type only.

Parts other than "K" and "S" marked are used for all color types.

Ref. No.	Part No.	Part Name & Description	Remarks	Ref. No.	Part No.	Part Name & Description	Remarks
		INTEGRATED CIRCUIT (S)				SWITCH (ES)	
IC101	AN6558F	IC, PHONO EQ AMP.		S1	ESB8249V	SW, POWEROR/LOUDNESS	Δ
IC301	UPC4570C	IC, TONE AMP.		S101	RSR4B003	SW, INPUT SELECTOR	
IC501	SVI3203	IC, POWER AMP.		S103	ESB68115	SW, TAPE MONITOR/LOUDNESS	
		TRANSISTOR (S)		S301	ESB68107	SW, TONE CONTROL	
				S501	RSP2002	SW, SPEAKER SELECTOR	
Q501	2SA92E	TRANSISTOR				JACK (S)	
		DIODE (S)		JK1	SJS9231-1B	AC INLET	Δ
D501	MA165TA	DIODE		JK101	SJF3067NJ	TUNER/PHONO/GND	
D553	MA4160MTA	DIODE		JK102	SJF3069N	CD/AUX	
D601	1SR35200TB	DIODE	Δ	JK103	SJF3069N	TAPE2/ADAPT	
D602	LN018472PH	L. E. D		JK104	SJF3069N	TAPE1/DAT	
D701-704	P300DLF	DIODE	Δ	JK501	SJF4819	SPEAKERS	
D751	MA4160MTA	DIODE		JK502	SJJD19	HEADPHONES	
D752, 753	MA4082MTA	DIODE		CN103, 104	SJS50880WL	SOCKET (8P)	
		VARIABLE RESISTOR (S)		CN105	SJS50780WL	SOCKET (7P)	
VR201	EWJKXA090B15	V. R. VOLUME CONTROL		CN201	SJS50780WL	SOCKET (7P)	
VR202	EWHFDA014G15	V. R. BALANCE CONTROL		CN401	SJS50780WL	SOCKET (7P)	
VR301	EWXC2XA000C15	V. R. TREBLE CONTROL		CP103, 104	SJT30847WL	CONNECTOR (8P)	
VR302	EWXC2XA000C15	V. R. BASS CONTROL		CP105	SJT30747WL	CONNECTOR (7P)	
		THERMISTOR (S)		CP201	SJT30747WL	CONNECTOR (7P)	
TH201, 202	ERTD2ZHL104T	THERMISTOR		CP401	SJT30747WL	CONNECTOR (7P)	
		COIL (S)				FUSE HOLDER	
L1	SLQZ650MH49	COIL	Δ (EG)	FC1, 2	SJT390	FUSE HOLDER	Δ
L501, 502	SLQY07G-30	COIL				RELAY	
		TRANSFORMER (S)		RL501	SSY126	RELAY	
T1	RTP1N5E004-V	POWER TRANSFORMER	Δ (E, E5, EG)				
T1	RTP1N5B003-V	POWER TRANSFORMER	Δ (EB)				
		FUSE (S)					
F1	XBA2C20TBO	FUSE 250V T2A	Δ				

Notes : * Capacity value are in microfarads (uF) unless specified otherwise, P=Pico-farads (pF) F=Farads (F)
 * Resistance values are in ohms, unless specified otherwise, 1K=1,000 (OHM) , 1M=1,000k (OHM)

Ref. No.	Part No.	Values & Remarks	Ref. No.	Part No.	Values & Remarks
		RESISTORS			CAPACITORS
R101, 102	ERDS2TJ102T	1/4W 1K	C1	ECKWNS103ZVS	500V 0.01U Δ
R105, 106	ERDS2TJ224T	1/4W 220K	C101, 102	ECBT1H120J	50V 12P
R109, 110	ERDS2TJ391T	1/4W 390	C103, 104	ECBT1H181KB5	50V 180P
R113, 114	ERDS2TJ563T	1/4W 56K	C105, 106	ECBT1H100J5	50V 10P
R117, 118	ERDS2TJ271T	1/4W 270	C107, 108	ECEA0JK330B	6.3V 33U
R123, 124	ERDS2TJ680T	1/4W 68	C109, 110	ECBT1H391KB5	50V 390P
R125, 126	ERDS2TJ184T	1/4W 180K	C113, 114	ECQM1H223KV3	50V 0.022U
R127, 128	ERDS2TJ123T	1/4W 12K	C115, 116	ECQM1H682KV3	50V 6800P
R129, 130	ERDS2TJ563T	1/4W 56K	C117, 118	ECEA1HKN010B	50V 1U
R131, 132	ERDS2TJ102T	1/4W 1K	C119, 120	ECQM1H472KV3	50V 4700P
R201-210	ERDS2TJ102T	1/4W 1K	C121, 122	ECKR1H103ZF5	50V 0.01U
R211, 212	ERDAS3G563T	1/4W 56K	C123, 124	ECEA1HPX3R3B	50V 3.3U
R213, 214	ERDS2TJ183T	1/4W 18K	C201-210	ECBT1H101KB5	50V 100P
R219, 220	ERDAS3G272T	1/4W 2.7K	C213, 214	ECQV1H563JZ3	50V 0.056U
R221-224	ERDS2TJ471T	1/4W 470	C221-224	ECBT1H181KB5	50V 180P
R301, 302	ERDAS3G561T	1/4W 560	C301, 302	ECEA1HPX3R3B	50V 3.3U
R303, 304	ERDS2TJ823T	1/4W 82K	C303, 304	ECBT1H101KB5	50V 100P
R305, 306	ERDS2TJ474T	1/4W 470K	C305, 306	ECBT1H820KB5	50V 82P
R307, 308	ERDS2TJ392T	1/4W 3.9K	C307, 308	ECEA1HPX4R7B	50V 4.7U
R309, 310	ERDS2TJ223T	1/4W 22K	C309, 310	ECBT1H390J5	50V 39P
R311, 312	ERDS2TJ102T	1/4W 1K	C311, 312	ECEA1CPX100B	16V 10U
R313, 314	ERDS2TJ472T	1/4W 4.7K	C313, 314	ECQV1H823JZ3	50V 0.082U
R315, 316	ERDAS3G392T	1/4W 3.9K	C315, 316	ECQM1H153KV3	50V 0.015U
R317, 318	ERDAS3G223T	1/4W 22K	C317, 318	ECQM1H183KV3	50V 0.018U
R319, 320	ERDS2TJ333T	1/4W 33K	C319, 320	ECQM1H272KV3	50V 2700P
R501, 502	ERDS2TJ392T	1/4W 3.9K	C321, 322	ECKR1H103ZF5	50V 0.01U
R503, 504	ERDS2TJ563T	1/4W 56K	C501, 502	ECEA1HPX3R3B	50V 3.3U
R505, 506	ERDS2TJ222T	1/4W 2.2K	C503, 504	ECBT1H271KB5	50V 270P
R507, 508	ERDS2TJ563T	1/4W 56K	C505, 506	ECEA1CK220B	16V 22U
R509, 510	ERDS2TJ470T	1/4W 47	C507, 508	ECCR1H100K5	50V 10P
R511, 512	ERD25FVJ100T	1/4W 10 Δ	C509, 510	ECBT1H151KB5	50V 150P
R513	ERDS2TJ223T	1/4W 22K	C511, 512	ECKR1H473ZF5	50V 0.047U
R514	ERDS1FVJ682T	1/2W 6.8K Δ	C513	ECEA1CU101B	16V 100U
R515	ERDS2TJ473T	1/4W 47K	C514	ECEA1HJ330B	50V 33U
R516	ERG2SJ681H	2W 680	C515	ECEA1HN100SB	50V 10U
R517, 518	ERDS2TJ561T	1/4W 560	C516	ECEA1HRN2R2B	50V 2.2U
R520	ERDS2TJ124T	1/4W 120K	C518, 519	ECKR1H473ZF5	50V 0.047U
R523, 524	ERG2SJ331H	2W 330	C523, 524	ECBT1H102KB5	50V 1000P
R528	ERDS2TJ684T	1/4W 680K	C601	ECEA1CU470B	16V 47U
R601	ERDS1FVJ120T	1/2W 12 Δ	C705, 706	ECEA1HV682UM	50V 6800U
R602	ERDS2TJ680T	1/4W 68	C711	ECKR2H103ZU	500V 0.01U Δ
R751	ERG2ANJP152S	2W 1.5K Δ	C712	ECKR1H473ZF5	50V 0.047U
R752	ERG2ANJP102S	2W 1K Δ	C731-734	ECQM1H473KV3	50V 0.047U
			C751, 752	ECEA1EPX470B	25V 47U

EXPLODED VIEW

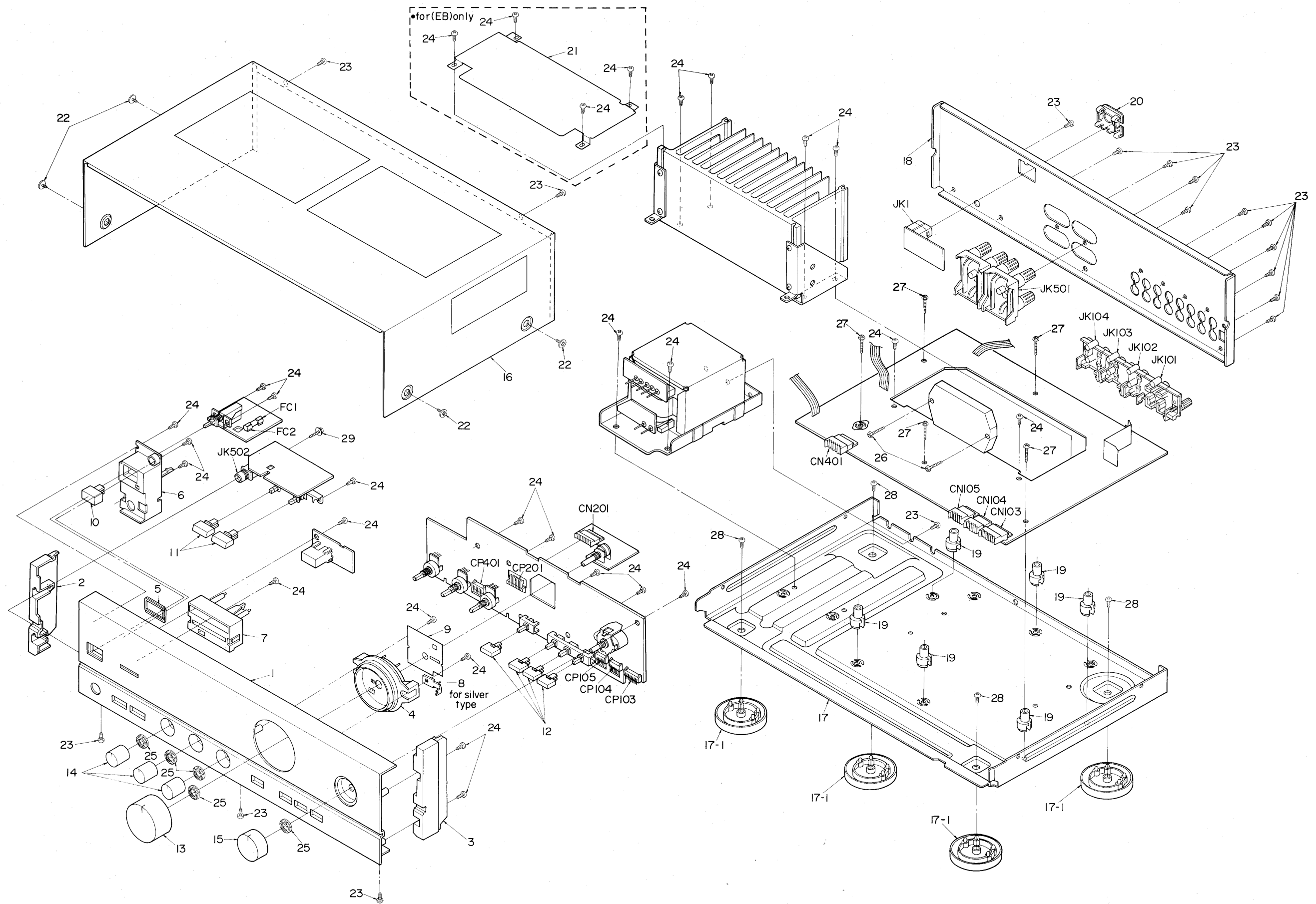

Ref. No.	Part No.	Part Name & Description	Remarks	Ref. No.	Part No.	Part Name & Description	Remarks
		CABINET PARTS				PACKING MATERIALS	
1	RFKGU810E-K	FRONT PANEL ASS'Y	K	P1	RPG0369	CARTON BOX	K
1	RFKGU810E-S	FRONT PANEL ASS'Y	S	P1	RPG0370	CARTON BOX	S
2	RGK0098-K	ORNAMENT (LEFT)	K	P2	SPS5185	PAD (AC CORD)	
2	RGK0098-S	ORNAMENT (LEFT)	S	P3	SPS5255	PAD (FRONT)	
3	RGK0099-K	ORNAMENT (RIGHT)	K	P4	SPS5256-1	PAD (REAR)	
3	RGK0099-S	ORNAMENT (RIGHT)	S	P5	SPP701	PROTECTION COVER	
4	RGK0212-K	ORNAMENT (VOLUME)	K			ACCESSORIES	
4	RGK0212-S	ORNAMENT (VOLUME)	S				
5	RGQ0006-1	ORNAMENT (POWER BUTTON)	K	A1	RFKSU810E-K	INSTRUCTIONS MANUAL	(E, E5)
5	RGQ0006-1S	ORNAMENT (POWER BUTTON)	S	A1	RQT0302-G	INSTRUCTIONS MANUAL	(EB)
6	RMRO136-K	HOLDER	K	A1	RQT0304-D	INSTRUCTIONS MANUAL	(EG)
6	RMRO136-S	HOLDER	S	A2	SFDAC05E03	AC POWER CORD	△ (E, E5, EG)
7	RFKNU810E-K	INDICATOR ASS'Y	K	A2	SJA193	AC POWER CORD	△ (EB)
7	RFKNU810E-S	INDICATOR ASS'Y	S	A3	RQAD013	WARRANTY CARD	
8	SUS800	EARTH SPRING	S	A4	RQCB0169	SERVICENTOR LIST	
9	SMC6407-2	SHIELD PLATE (VOLUME)					
10	RGU0030	PUSH BUTTON, POWER	K				
10	RGU0030-S	PUSH BUTTON, POWER	S				
11	RGU0118-K	PUSH BUTTON, SP. SELECT	K				
11	RGU0118-S	PUSH BUTTON, SP. SELECT	S				
12	RGU0120-K	PUSH BUTTON, TAPE/LOUD/TONE	K				
12	RGU0120-S	PUSH BUTTON, TAPE/LOUD/TONE	S				
13	RGW0025A-K	KNOB, VOLUME	K				
13	RGW0025A-S	KNOB, VOLUME	S				
14	RGW0028-K	KNOB, TONE	K				
14	RGW0028-S	KNOB, TONE	S				
15	RGW0063-K	KNOB, INPUT SELECTOR	K				
15	RGW0063-S	KNOB, INPUT SELECTOR	S				
16	RKMO036A-K	CABINET	K				
16	RKMO036A-S	CABINET	S				
17	RFKJU810E-K	BOTTOM BOARD					
17-1	RKA0009-1	FOOT					
18	RGRO019D-A	REAR PANEL	(E)				
18	RFKHU810E5-K	REAR PANEL ASS'Y	(E5)				
18	RGRO019D-C	REAR PANEL	(EB)				
18	RGRO019D-B	REAR PANEL	(EG)				
19	SHE187-2	SPACER					
20	SJS9231A	AC INLET COVER					
21	RMQ0069	COVER	(EB)				
22	SNE2129-1	SCREW	K				
22	SNE2129	SCREW	S				
23	XTBS3+8JFZ1	SCREW					
24	XTB3+8JFZ	SCREW					
25	SNE4021-1	NUT					
26	XTB3+16JFZ	SCREW					
27	XTB3+20J	SCREW					
28	XTB3+6J	SCREW					
29	XTWS3+8T	SCREW					