

Tecumseh Carburetor Picture Breakdown

This is a basic Tecumseh old-style float type carburetor.

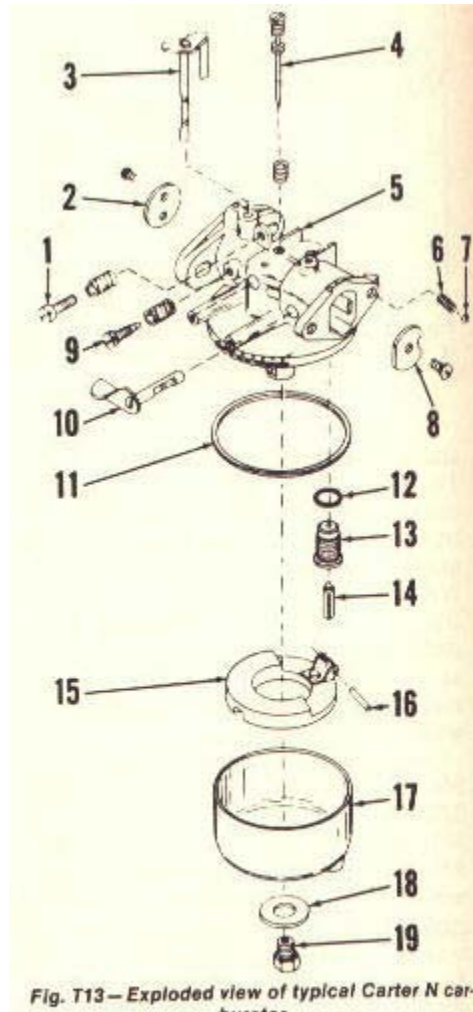

Fig. T13—Exploded view of typical Carter N carburetor.

- | | |
|-------------------------|----------------------|
| 1. Idle speed screw | 11. Bowl gasket |
| 2. Throttle plate | 12. Gasket |
| 3. Throttle shaft | 13. Inlet valve seat |
| 4. Main adjusting screw | 14. Inlet valve |
| 5. Carburetor body | 15. Float |
| 6. Choke shaft spring | 16. Float shaft |
| 7. Ball | 17. Fuel bowl |
| 8. Choke plate | 18. Gasket |
| 9. Idle mixture screw | 19. Bowl retainer |
| 10. Choke shaft | |

This is a basic Tecumseh new-style float type carburetor.

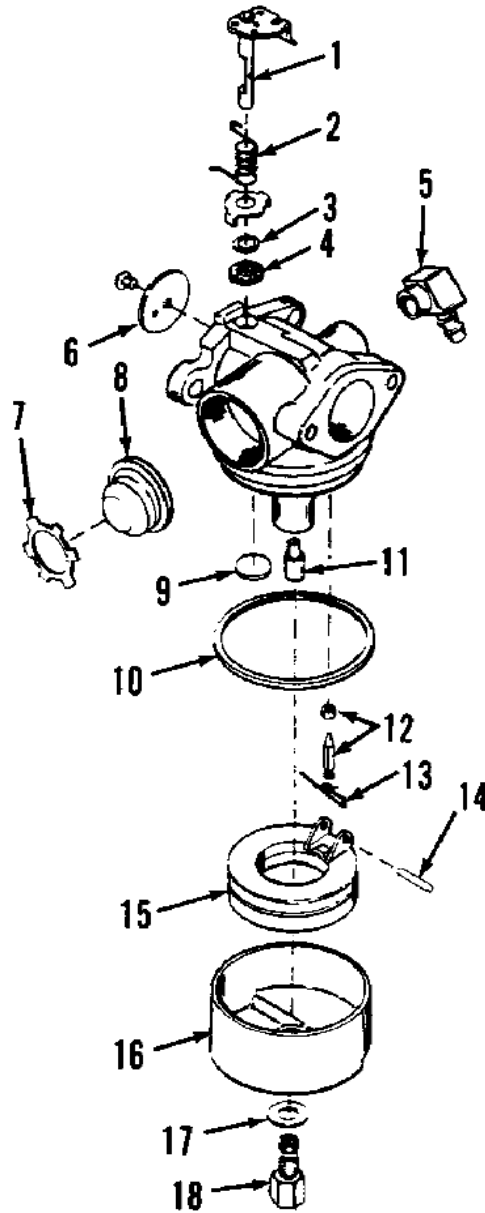

Fig. T17—Exploded view of Series VI carburetor. Dual System carburetor is similar.

- | | |
|-----------------------|------------------------------|
| 1. Throttle shaft | 10. Gasket |
| 2. Spring | 11. Fuel well spacer |
| 3. Washer | 12. Fuel inlet needle & seat |
| 4. Felt washer | 13. Clip |
| 5. Fuel inlet fitting | 14. Hinge pin |
| 6. Throttle plate | 15. Float |
| 7. Retainer | 16. Fuel bowl |
| 8. Primer bulb | 17. Washer |
| 9. Welch plug | 18. High speed bowl nut |

When installing the rubber seat for some of these carburetors be sure it is like this.

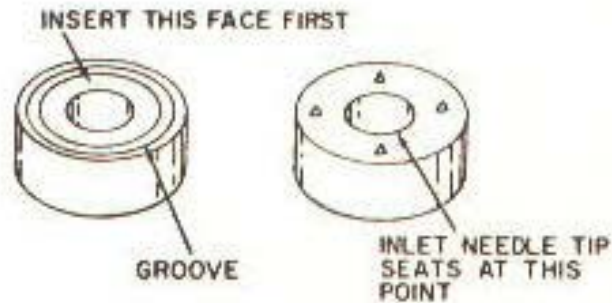
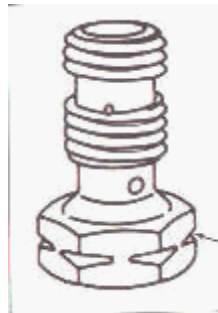

Fig. T7—The Viton seat used on some Tecumseh carburetors must be installed correctly to operate properly. All-metal needle is used with seat shown.

From, <http://www.repairfaq.org/sam/lmfaq.htm>, the following info was used.

The small hole in the hollow bolt on the bottom is most critical. Make sure it is cleaned down to the shiny brass and that this hole is unblocked and fully open:

I first use carburetor cleaner inside and out with cotton swabs to remove all traces of gunk from the inside. Use as many as needed till no more discoloration shows up. Then, use the broken end of a wooden toothpick or pop sickle stick to clear the .5 mm diameter hole in the side. In severe cases, this hole may not even be immediately visible due to the varnish and gunk buildup.



If this hole is narrowed or clogged, the engine may start but then die in a few seconds. Gas enters the reservoir in the nut slowly or is forced in by priming but the normal suction cannot replenish it quickly enough.

This was submitted by one of my readers:

The small hole in the hollow bolt on the bottom is most critical. There is one hole that passes through the bolt from side to side and one hole that extends up the center of the bolt from this hole and into the bottom of the well of the bolt.

From the Lawn Mower Repair Man's site: "Another tip that is just for Tecumseh is how the needle is hung from the float. The picture I took for this didn't come out clear and when I get one it will be added here as well. The wire clip that connects the float needle to the float is what is of concern here. The open end of the wire that hangs from the float must aim towards the air intake or air filter side of the carb. If it's pointing toward the engine side, the needle won't center correctly and may leak. This makes absolutely no sense to me but it's an advisory from Tecumseh I picked up on years ago. Once I started following their advise, the vast majority of un-explained flooding carbs (after being rebuilt) mysteriously ended. So although the reason isn't readily apparent, it does work."

The float setting should be like this.

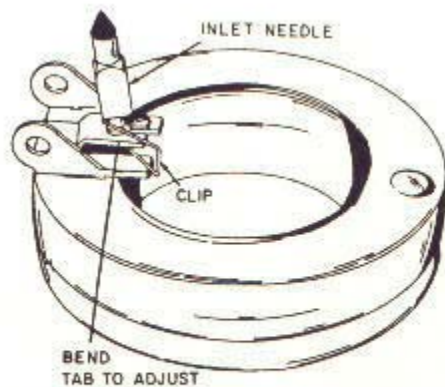

Fig. T5—View of float and fuel inlet valve needle. The valve needle shown is equipped with a resilient tip and a clip. Bend tab shown to adjust float height.

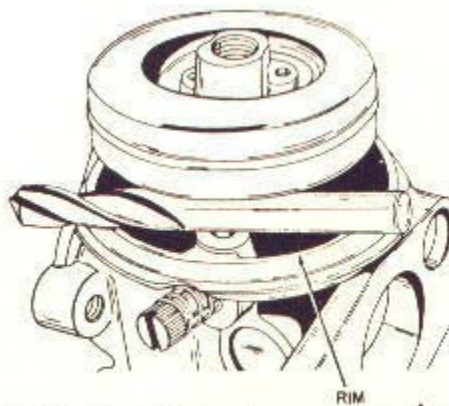

Fig. T8—Float height can be measured on some models by using a drill as shown. Refer to text for correct specifications.

The drill bit size is: 11/64. Also this distance can be measured and should be 0.200 to 0.220 inch or 5.1 to 5.6mm.

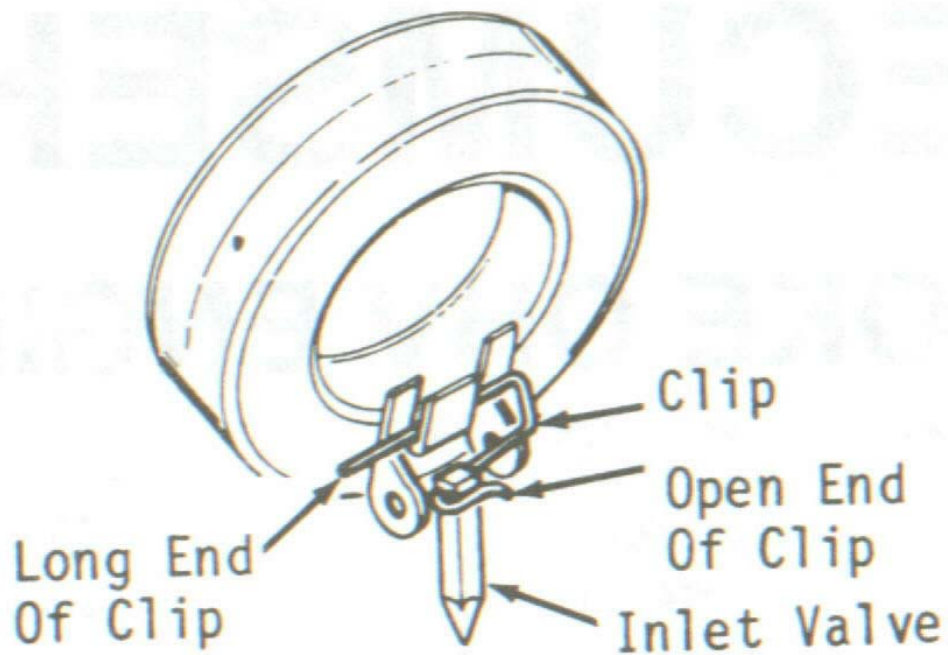

Fig. T303—Install inlet valve clip so long end points toward intake end of carburetor.

When checking a metal float be sure to shake it and listen for signs of gas inside the float. If you can feel or hear anything moving inside the float, the float should be replaced.

This is a basic Tecumseh diaphragm carb.

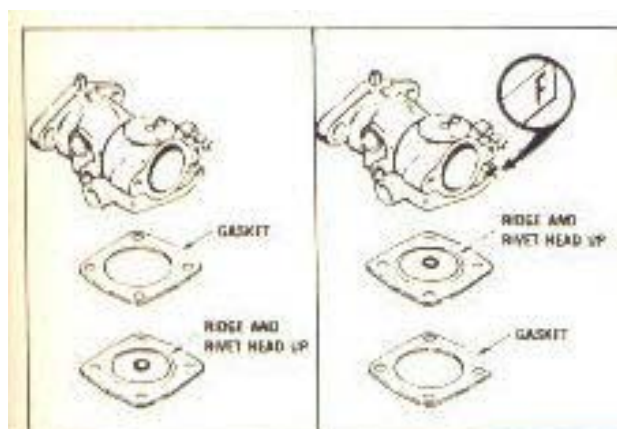

Fig. T2A—Illustration showing correct position of diaphragm on carburetors unmarked and marked with a "F".

Mechanical Governor. Some engines are equipped with a mechanical (flyweight) type governor. To adjust the governor linkage, loosen governor lever screw. Twist protruding end of governor shaft counter-clockwise as far as possible on vertical crankshaft engines, clockwise on horizontal crankshaft engines. On all models, move the governor lever until carburetor throttle shaft is in wide open position, then tighten governor lever clamp screw.

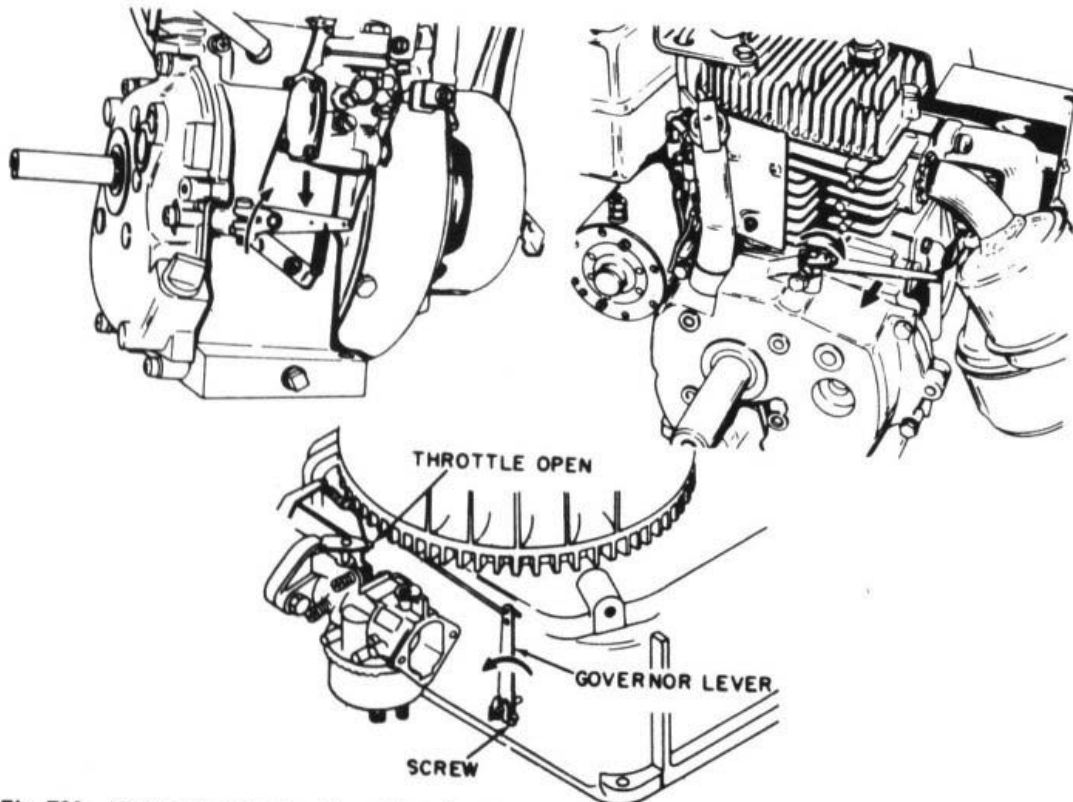

Fig. T28—Views showing location of mechanical governor lever and direction to turn when adjusting position on governor shaft.

Send comments or suggestions to:
JR Combs, okie48@hotmail.com

Copyright © 2002 JR Combs