

PRO50 Transom Closer

Instructions

Concealed Overhead Door Closer Centre Pivoted – Double or Single Action

IMPORTANT: This closer should be installed by a competent installer who must pass these instructions on to the site or maintenance manager once the closer has been satisfactorily installed.

No responsibility can be accepted by the manufacturers if these installation instructions are disregarded.

For front bracket, you have two options (1) or (2), depending on the fixing hole you used.

Door stops must be fitted to prevent door opening beyond 130°.

HOLD OPEN OPTIONS

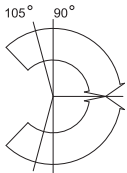

CLOSING RANGE AND ADJUSTMENT

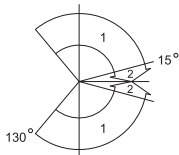

- 1. CLOSING RANGE
- 2. LATCHING RANGE

ADJUSTING VALVES FOR LATCHING & CLOSING SPEEDS

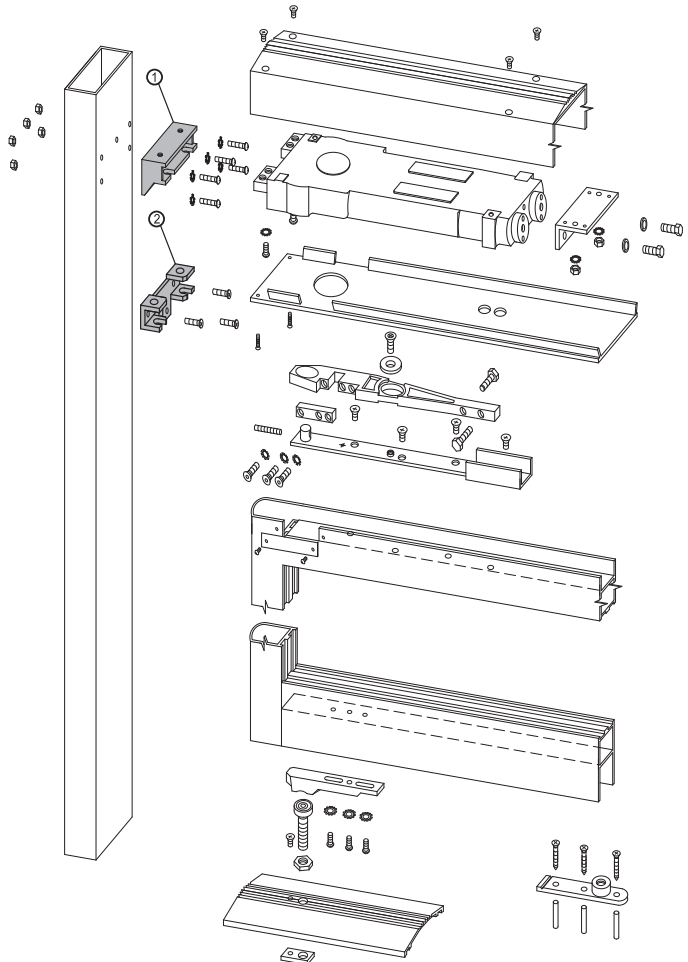
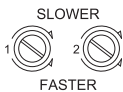

alpro® *First Choice for Locking Solutions*

T 01202 676262 **F** 01202 680101 **E** alpro@iecltd.co.uk **W** www.alpro.co.uk

PRO50 Transom Closer

Instructions

PREPARATION

Prepare transom and cover plate to accept closer mechanism as detailed.

Fix jamb bracket to side frame with 5 No. M5 screws, washers and nuts.

Fix angle bracket to inside of transom with 2 No. M6 csk screws provided.

Locate closer into jamb bracket and swing mechanism up into transom.

Secure mechanism to brackets with screw, bolts and washers provided.

Secure cover plate to transom.

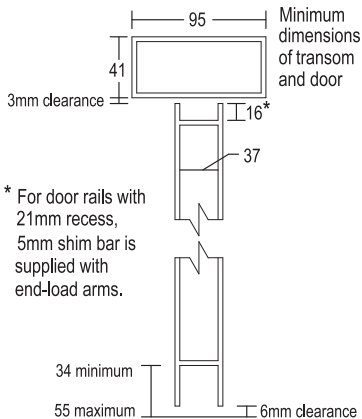

TRANSOM HEADER BAR, 70MM PIVOT HEAD

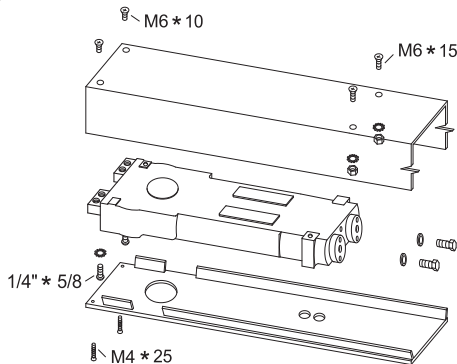
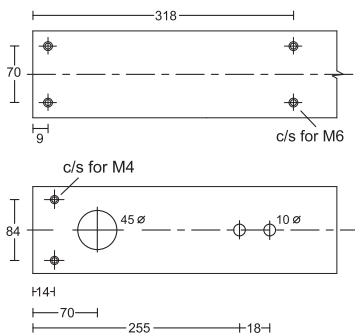

HINGE JAMB

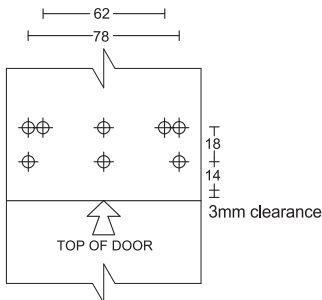

Select fixing holes most suitable for section and drill clearance size for M5 screws.

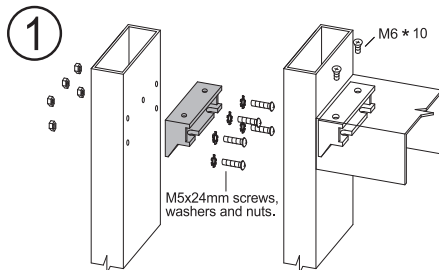

For front bracket, you have two option ① or ②, depend on the fixing hole you used.

PRO50 Transom Closer Instructions

PREPARATION

Prepare transom and cover plate to accept closer mechanism as detailed.

Fix jamb bracket to side frame with 3 No. M6 screws.

Fix angle bracket to inside of transom with 2 No. M6 csk screws provided.

Locate closer into jamb bracket and swing mechanism up into transom.

Secure mechanism to brackets with screw, bolts and washers provided.

Secure cover plate to transom.

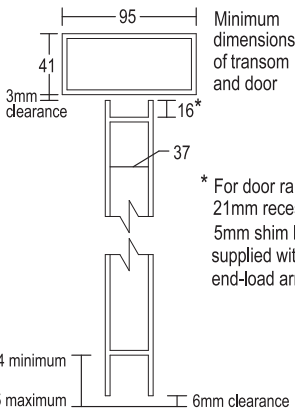

* For door rails with 21mm recess, 5mm shim bar is supplied with end-load arms.

TRANSOM HEADER BAR, 65MM PIVOT HEAD

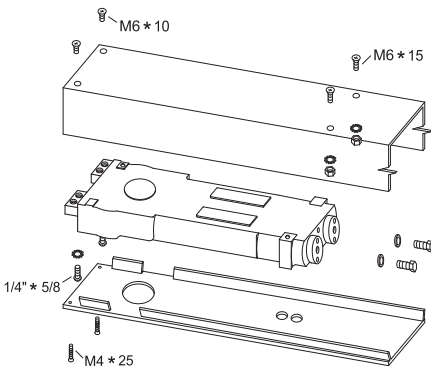
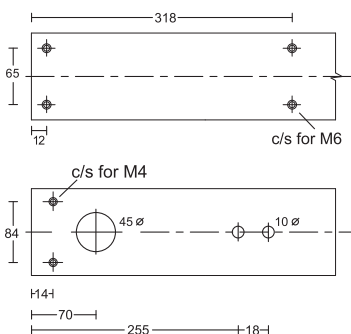

HINGE JAMB

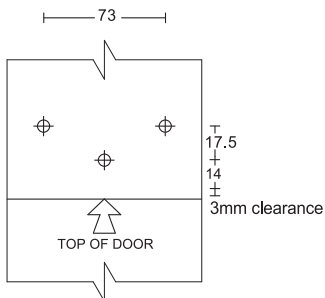

Select fixing holes most suitable for section and drill clearance size for M6 screws.

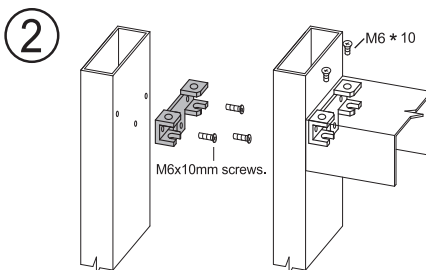

PRO50 Transom Closer Instructions

END LOAD – 70MM PIVOT POINT DOOR, STOP RAIL

Prepare the top rail of the door as detailed, ensuring heel of door is cut away to give access to spindle during door hanging.

Fix arm channel to top rail with 4 No. M6 csk screws (A). Insert arm into channel and secure with M6 csk socket head screw (B).

Insert M6 socket head alignment bolt, washer and locknut (C) into arm through slot in end of channel.

Adjust alignment bolts (D) on to side of channel.

Note: Datum hole indicating pivot point

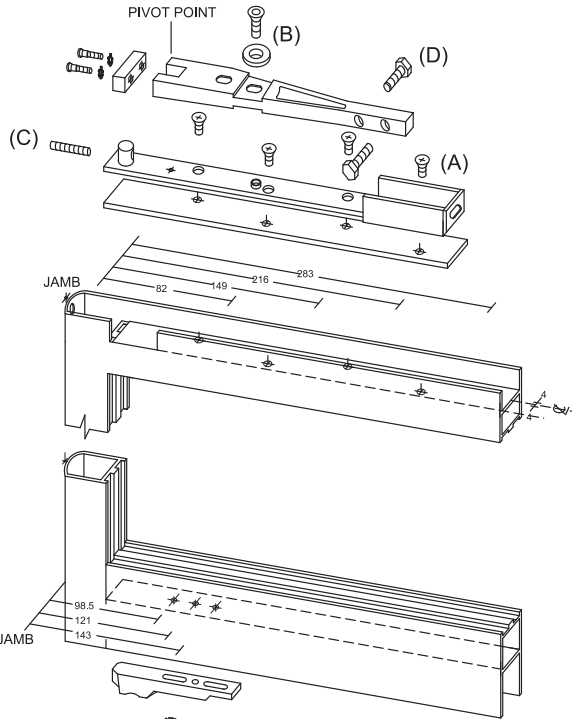

BOTTOM RAIL

Prepare the bottom rail of the door as detailed, ensuring heel of door is cut away to allow for loading of floor pivot.

Secure door plate of bottom pivot assembly to bottom rail of door with 2 No. M6x16mm long set screws and shakeproof washers (E) using only the slotted holes.

Check that projection of the bearing plate beyond the heel of the door gives the working clearance required.

Slacken the 2 fixed set screws and adjust if necessary. Finally drill and tap bottom rail for 3rd M6x16mm long set screw and fix screw to maintain this position. Tighten all screws.

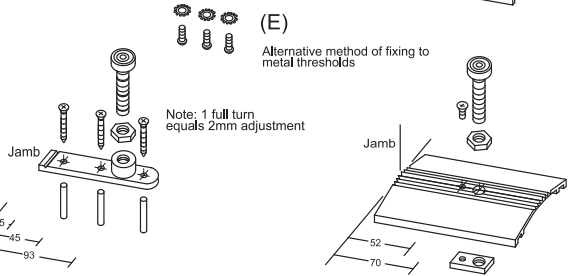

FLOOR PIVOT

Determine overall height of bottom pivot assembly, allowing desired clearance, and secure the locknut.

Cut off excess thread flush with underside of plate or recess flooring to accommodate.

Fix bearing plate on to the floor with the extended end against the face of the jamb.

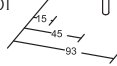

TO ERECT THE DOOR PAIRS OF DOORS

Slide heel end of first door on to top and bottom pivots. Open first door to 90° and wedge or hold open.

Fit and firmly secure clamp block to arm with 2 cap head screws and lockwashers. Slide second door over pivots and secure as first door.

Fix cover plates to heel cutouts.

SINGLE DOOR

Turn spindle to hold open position or in the case of no hold open closer, screw in door closing speed regulator and turn spindle through 90°.

Slow return of spindle will allow door to be slide on to pivots from the open position.

Fit and firmly secure clamp blocks to arm with 2 cap head screws and lockwashers. Fix cover plates to heel cutouts.

PRO50 Transom Closer

Instructions

SIDE LOAD, 70MM PIVOT POINT DOOR, STOP RAIL

Prepare the top rail of the door as detailed, ensuring that internal door face is cut away to give access to spindle during door hanging and hole to be drilled in heel of door to give access to adjustment screw (C).

Fix arm channel to top rail with 4 No. M6 csk screws (A). Insert arm into channel and secure with M6 csk socket head screw (B).

Insert M6 socket head alignment bolt, washer and locknut (C) into arm through slot in end of channel.

Adjust alignment bolts (D) on to side of channel.

Note: Datum hole indicating pivot point

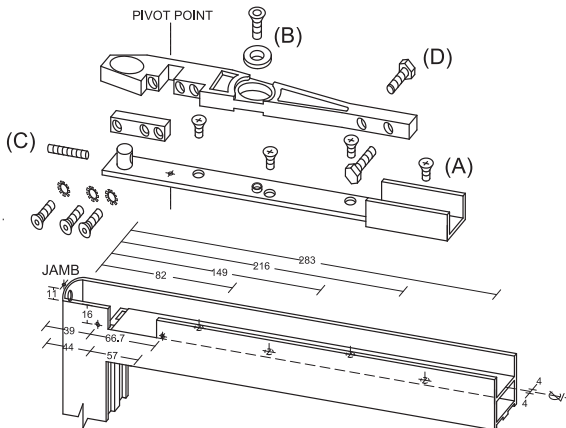

BOTTOM RAIL

Prepare the bottom rail of the door as detailed.

Secure door plate of bottom pivot assembly to bottom rail of door with 2 No. M6x16mm long set screws and shakeproof washers (E) using only the slotted holes.

Check that projection of the bearing plate beyond the heel of the door gives the working clearance required.

Slacken the 2 fixed set screws and adjust if necessary. Finally drill and tap bottom rail for 3rd M6x16mm long set screw and screw to maintain this position. Tighten all screws.

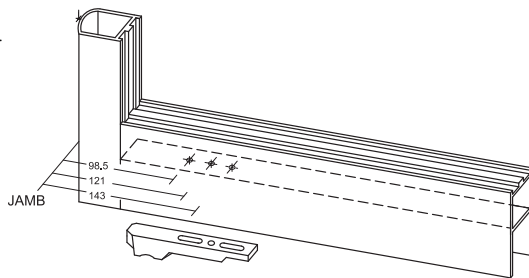

(E)
Alternative method of fixing to metal thresholds

FLOOR PIVOT

Determine overall height of bottom pivot assembly, allowing desired clearance, and secure the locknut.

Cut off excess thread flush with underside of plate or recess flooring to accommodate.

Fix bearing plate on to the floor with the extended end against the face of the jamb.

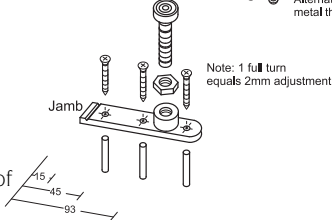

Note: 1 full turn equals 2mm adjustment

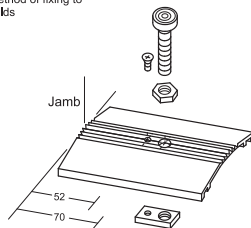

TO ERECT THE DOOR

Holding door at an angle of approx. 15°, lower on to bearing plate pivot and gradually swing door vertical until recess in top of door locates against closer spindle.

Note: To ease the hanging of single action doors, temporarily remove head stop if possible. Wedge door in the vertical position whilst spindle clamping block is located

against spindle and securely tighten clamping screws using wrench key provided. (Maximum tightness can be obtained by using the palm of the hand against the wrench key). Fit 'cut out' cover plate.

Check the door closes to a position that aligns with door frame or adjacent door leaf. Any correction is obtained by adjusting alignment bolts (D) and alignment screw (C).

IEC Limited Harwell Road Nuffield Estate Poole Dorset BH17 0BD Great Britain

T 01202 676262
F 01202 680101
E alpro@iecltd.co.uk
W www.alpro.co.uk

Registered in England & Wales 1925537
 © June 2009 IEC. All rights reserved.
 All dimensions are nominal and subject to tolerances