

# User Manual

## PowerWAVE 8000DPA ST

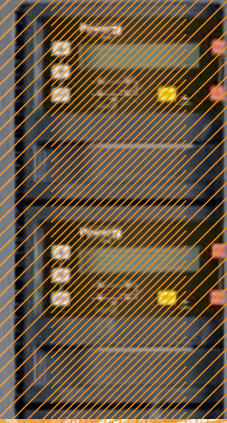

Pioneering solutions for  
total power protection



## Document Control

ISSUE	DATE	REVISION SUMMARY
Issue 1.0.0	09-09-09	Initial issue.
Issue 1.1.0	01-06-10	GENERAL: Style update to align with Kohler documentation.
Issue 1.2.0	18-11-11	Update illustrations, specification and general error corrections Part number changed to 454-01-00.
Issue 1.3.0	05-04-13	Updated contact details
Issue 1.3.1	28-05-13	Updated 24Hr contact details
Issue 1.4.0	20-12-13	Added ST-200 model details and updated layout.

Uninterruptible Power Supplies Ltd has taken every precaution to produce an accurate, complete and easy to understand manual and will therefore assume no responsibility nor liability for direct, indirect or accidental personal or material damage due to any misinterpretation of or accidental mistakes in this manual.

© 2005 **Uninterruptible Power Supplies Ltd**

This manual may not be copied nor reproduced without written permission of Uninterruptible Power Supplies Ltd.

# Table of Contents

<b>1: Safety</b>	<b>1</b>
1.1 Description of symbols used in this manual	1
1.2 User precautions	1
<b>2: General Description</b>	<b>2</b>
2.1 Reliability and Quality Standards	2
2.2 PW8000DPA ST System	2
2.3 System Configuration	2
2.4 Advanced Design Features	3
2.4.1 Input booster technology	3
2.4.2 Flexible battery management	4
2.4.3 Decentralized Parallel Architecture (DPA)	4
2.5 Warranty	4
2.5.1 Extended warranty	5
2.5.2 Additional service/maintenance support	5
2.6 Extended Service enquiry form	6
<b>3: Installation</b>	<b>7</b>
3.1 Introduction	7
3.2 Receipt of the UPS	7
3.2.1 Site transportation	7
3.3 Unpacking	8
3.3.1 Nameplate	8
3.4 Batteries	8
3.5 Storage	9
3.5.1 UPS	9
3.5.2 Battery	9
3.6 Positioning	9
3.6.1 Planning the installation	9
3.7 UPS Power Cabling (preparation and planning)	10
3.7.1 General requirements	10
3.8 Connecting the UPS input supply	16
3.8.1 Safety notes	16
3.8.2 Preparing the input cabling	16
3.8.3 Connecting the UPS input power cables	16
3.9 Connecting the UPS Output Supply	20
3.9.1 Safety notes	20
3.9.2 Preparation for the output cabling	20
3.9.3 Connecting the UPS output cables	20
3.10 Connecting the batteries	21
3.10.1 Safety Notes	21
3.10.2 Battery cabling	21
3.10.3 Connecting the battery cables	22
3.10.4 Internal battery for ST-40 and ST-60 cabinets	22
3.10.5 External battery enclosures	24

3.11	Module interfacing facilities	28
3.11.1	Smart Port JD1 (Serial RS 232) and USB Port	28
3.11.2	X1 & X2 Dry Port (volt-free contacts)	29
<b>4:</b>	<b>Operation</b>	<b>31</b>
4.1	Commissioning	31
4.2	UPS control panel	31
4.2.1	Power Management Display (PMD)	32
4.2.2	Mimic LED indicators	32
4.2.3	Operator keys	32
4.3	Description of the LCD display	33
4.3.1	Status screens	33
4.3.2	Main menu screen	34
4.3.3	Event log menu screen	34
4.3.4	Measurements menu screen	34
4.3.5	Commands menu screen	35
4.3.6	UPS Data menu screen	35
4.3.7	Set-Up Service menu screen	35
4.3.8	Set-up User menu screen	36
4.3.9	Set-Up Service menu screen	36
4.4	Operating modes	37
4.4.1	On-line (inverter) mode	37
4.4.2	On-bypass (line-interactive) mode	37
4.4.3	Maintenance bypass mode	37
4.5	Operating Instructions	38
4.5.1	Starting the UPS system from the maintenance bypass	38
4.5.2	Individual UPS module start/stop procedure	39
4.5.3	Transfer to maintenance bypass mode	40
4.5.4	Complete system shutdown	41
4.6	Replacing a UPS module in a single module system	42
4.6.1	Extracting the UPS module	42
4.6.2	Refitting the UPS module	42
4.7	Replacing a UPS module in a REDUNDANT multi-module system	42
4.7.1	Extracting the UPS module	43
4.7.2	Refitting the UPS module	43
4.8	Replacing a UPS module in a CAPACITY multi-module system	43
4.8.1	Extracting the UPS module	43
4.8.2	Refitting the UPS module	44
<b>5:</b>	<b>Maintenance</b>	<b>45</b>
5.1	Introduction	45
5.2	System calibration	45
5.3	User responsibilities	45
5.4	Routine maintenance	45
5.5	Battery testing	46
5.6	Battery maintenance	46
5.7	Battery disposal and recycling	46
<b>6:</b>	<b>Troubleshooting</b>	<b>47</b>
6.1	Alarms	47
6.2	Menu, Commands, Event Log, Measurements,	47
6.3	Fault Identification and Rectification Messages and Alarms	47
6.4	Contacting Service	48

<b>7: Options</b>	<b>49</b>
7.1 Introduction	49
7.2 Remote emergency stop	49
7.3 Generator ON facilities	50
7.4 UPS Monitoring and automated control software	50
7.4.1 SNMP Card slots	50
7.4.2 The importance of UPS management	51
7.4.3 WAVEMON Shutdown and Monitoring Software	51
7.4.4 Functional description	52
7.4.5 Licensing	52
7.4.6 RCCMD Server shutdown	52
7.5 PowerREPORTER™ management software	53
7.5.1 Functional description	53
<b>8: Specification</b>	<b>55</b>
8.1 Mechanical Characteristics – UPS Cabinet	55
8.2 Mechanical Characteristics – UPS Module	56
8.3 Input Characteristics	56
8.4 Battery Characteristics	56
8.5 Battery Capacity Usage	56
8.6 Heat Dissipation Per Module With Non-Linear Load	57
8.7 Output Characteristics	57
8.8 Standards	57
8.9 Environmental Characteristics	58
8.10 Communication Options	58
8.11 Fuses & Cables Quick Reference	59





# 1 Safety

## 1.1 Description of symbols used in this manual



**WARNING:** The warning symbol is used where there is danger of an electrical shock, equipment damage or personal-injury.



**CAUTION:** The caution symbol is used to highlight important information to avoid possible equipment malfunction or damage.

## 1.2 User precautions



**WARNING:** Keep this manual with the UPS for future reference.



**WARNING:** The UPS and peripheral equipment must be installed and commissioned by suitably qualified and trained personnel who are aware of the potential shock hazards.



**WARNING:** Do not attempt to install this UPS system until you are satisfied that ALL the safety instructions and hazard warnings contained in this manual are read and fully understood.



**WARNING:** High leakage current!  
Ensure that the UPS has been correctly earthed before you connect the mains power supply!



**WARNING:** This UPS must not be started-up or put into use without having first been commissioned by a fully trained engineer authorised by the manufacturer.



**WARNING:** All servicing must be performed by qualified personnel. Do not attempt to service the UPS yourself. You run risk of exposure to dangerous voltages by opening or removing the UPS-covers! Uninterruptible Power Supplies Ltd will assume no responsibility nor liability due to incorrect operation or manipulation of the UPS.



**WARNING:** The PW8000DPA ST is a Class A UPS product (according to BS EN 62040). In a domestic environment the UPS may cause radio interference. In such an environment the user may be required to undertake additional measures.

# 2 General Description

## 2.1 Reliability and Quality Standards

Congratulations on your purchase of the PW8000DPA ST.

Using a unique modular construction, the PW8000DPA ST represents a completely new generation of medium power, 3 phase UPS-Systems, incorporating the latest technological developments in power engineering. High reliability, upgrade ability, low operating costs and excellent electrical performance are only some of the highlights of this innovative UPS solution.

Uninterruptible Power Supplies Ltd specialises in the design, building, installation and maintenance of Uninterruptible Power Systems. This compact and powerful UPS is just one example of our wide range of state-of-the-art power protection devices and will provide your critical equipment with a steady and reliable power supply for many years.

The criteria and methods which are used in the design, manufacture, and maintenance of Uninterruptible Power Supply systems are certified to International Standard ISO 9001/EN 29001 and ISO 14001. A full UPS Specification is given in Chapter of this manual.

## 2.2 PW8000DPA ST System

PW8000DPA ST is a truly modular system based on 10kVA or 20kVA UPS modules which can be connected in parallel to form a redundant-module system.

The UPS modules are assembled in a range of purpose-designed free-standing cabinets containing up to six UPS modules, batteries and system switch-gear.

Cabinet-mounted systems are rated according to the maximum number of 20kVA modules that can be housed – i.e. 40kVA, 60kVA, 80kVA, 120kVA and 200kVA (see Figure 2.1). The 40kVA and 60kVA cabinets also contain the UPS batteries whereas these must be located externally in the 80kVA, 120kVA and 200kVA cabinets.



**Key Point:** All the modules fitted within a cabinet must be of the same rating – i.e. it is not possible to mix 10kVA and 20kVA modules in the same parallel system.

## 2.3 System Configuration

The illustrations in Figure 2.1 show the available cabinets fully populated with either 2, 3, 4, 6 or 10 UPS modules; however each of the systems shown can operate with as little as a single module fitted.

Thanks to the advanced PW8000DPA ST system design, if a cabinet is not fully populated it is possible to add further modules, as required, to increase the system capacity without the need to power-down the system or in any way disrupt the load. This 'hot-swappable' design also means that individual modules can be exchanged while the equipment is running without the need to transfer the load to the bypass supply (depending on system redundancy and demanded load).

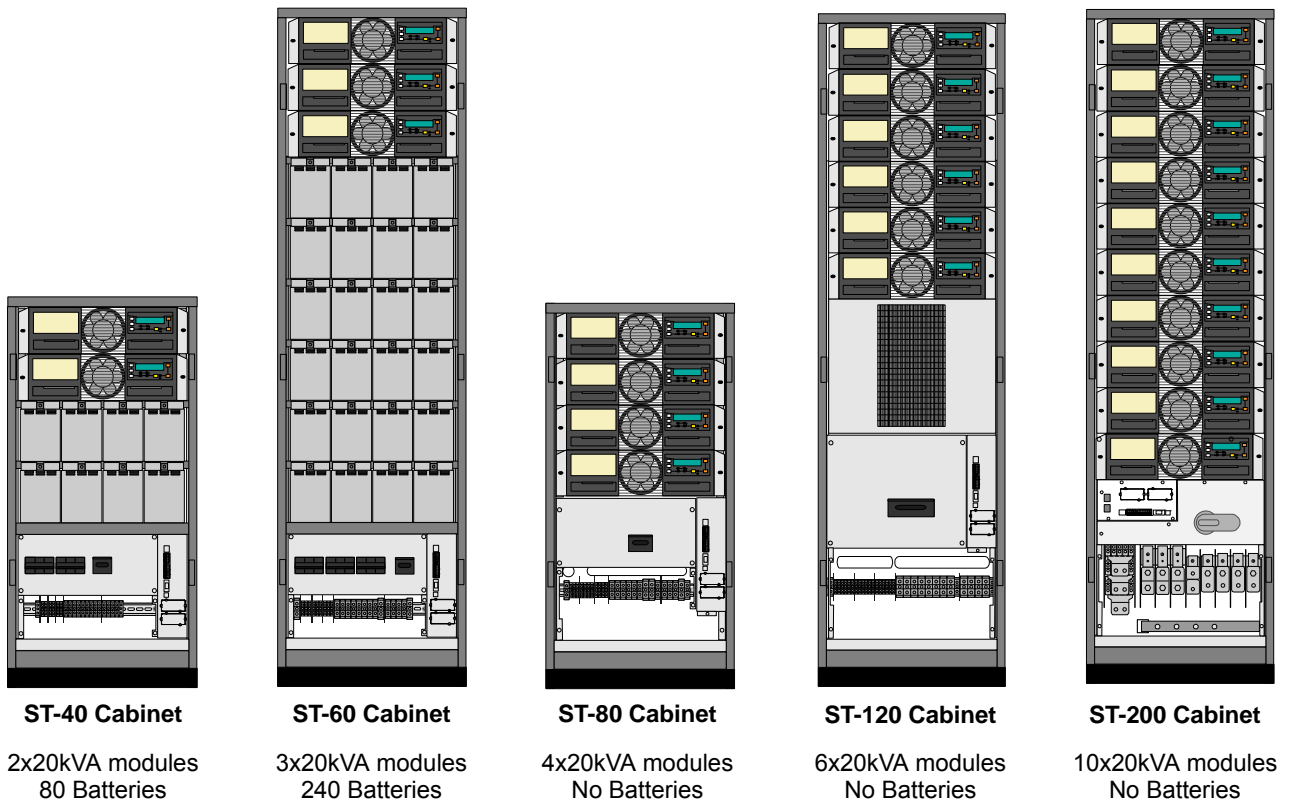

Figure 2.1 PW8000DPA ST module configuration

## 2.4 Advanced Design Features

### 2.4.1 Input booster technology

The UPS module's inbuilt advanced booster technology results in a perfect sinusoidal input power quality at 0.99 input power factor with a harmonic content of 3% THD(i). This leads to a more reliable total system operation and savings in generator and transformer sizing as losses in the windings are minimised. It also means that traditional harmonic filters are no longer required.

The high power factor presented by the UPS on the incoming mains supply minimises cabling and fusing costs due to the resulting lack of reactive power consumption. This, together with the accompanying low harmonic currents, provide the following benefits:

- No additional losses in wires and cables.
- No extra heating of transformers and generators.
- No over sizing of generators.
- No false circuit breaker tripping and malfunction.
- No erratic operation of computers, telecommunication, monitors, electronic test equipment etc.
- No resonance with power factor correction capacitors.

### 2.4.2 Flexible battery management

This equipment employs a flexible battery management which avoids premature deterioration of battery life by advanced management of battery charging and preventive failure diagnostics.

The major benefits are:

- AC-ripple free battery charging due to a dc-dc charger separated from the rectifier and inverter.
- Wide range of number of battery blocks (24-50 blocks of 12V; depending autonomy times).
- UPS's wide input voltage operating window extends the battery life due to fewer discharge cycles.
- Battery discharge protection caused by load jumps.
- Proactive battery protection from false manipulations and inadequate charging voltages.
- Proactive battery failure detection thanks to Advanced Battery Diagnosis (ABD) - Algorithm.
- User selectable battery tests.
- Optional temperature compensated charging to enhance battery life.

### 2.4.3 Decentralized Parallel Architecture (DPA)

The PW8000DPA ST system features DPA paralleling technology that provides n+x redundancy without introducing a single-point-of-failure. The modules utilizing the DPA technology are completely autonomous by means of individual power units, bypasses, CPUs, control panels and separate battery configuration.

## 2.5 Warranty

The PW8000DPA ST UPS is supplied with a limited warranty that the UPS and its component parts are free from defects in materials and workmanship for a period of one year from the date of commissioning, or fifteen months from the date of original delivery, whichever is the sooner.

This warranty is the only warranty given and no other warranty, express or implied, is provided.

This warranty is invalidated if the UPS is used without having been commissioned by a fully trained and authorised engineer.

The warranty does not apply to any losses or damages caused by misuse, abuse, negligence, neglect, unauthorised repair or modification, incorrect installation, inappropriate operating environment, accident, act of God, or inappropriate application.

If the UPS fails to conform to the above within the warranty period then Uninterruptible Power Supplies Ltd will, at its sole option, repair or replace the UPS. All replaced parts will remain the property of Uninterruptible Power Supplies Ltd.

As a general policy, Uninterruptible Power Supplies Ltd does not recommend the use of its products in:

- life support applications where failure or malfunction of the product can be reasonably expected to cause failure of the life support device, or to significantly affect its safety or effectiveness.
- applications concerned with direct patient care.

Uninterruptible Power Supplies Ltd will not knowingly sell its products for use in such applications unless it receives in writing assurances satisfactory to Uninterruptible Power Supplies Ltd that:

- the risks of injury or damage have been minimized.
- the customer assumes all such risks.
- the liability of Uninterruptible Power Supplies Ltd is adequately protected under the circumstances.



**CAUTION:** *The UPS contains batteries that must be re-charged for a minimum of 12 hours every six months (at 20°C) to prevent deep-discharging. Batteries that have been deep-discharged, for whatever reason, are not covered by this warranty.*

### 2.5.1 Extended warranty

The standard warranty may be enhanced by protecting the UPS with an extended warranty agreement (maintenance contract). An extended warranty agreement enhances the standard warranty by providing the following:

- Regular preventative maintenance inspections.
- Guaranteed speed of response to operational problems.
- 24 hour telephone support.
- Fully comprehensive cover (excluding batteries and capacitors).

Contact the Service Support Hotline on 0800 731 3269 for further details.

### 2.5.2 Additional service/maintenance support

In addition to providing support for the PW8000DPA ST UPS, Uninterruptible Power Supplies Ltd can provide maintenance and support on a wide range of different UPS products.

If you are interested in an extended warranty for your PW8000DPA ST UPS, or for any other UPS products you may have, please complete the enquiry form shown below and return or FAX it to:

Uninterruptible Power Supplies Ltd. Woodgate Bartley Wood Business Park Hook Hampshire RG27 9XA	Tel: 01256 386700 0800 731 3269 (24 Hr.) Fax: 01256 386701 Email: <a href="mailto:service@upspower.co.uk">service@upspower.co.uk</a>
--	---

## 2.6 Extended Service enquiry form

Fax to: 01256 386701

[www.upspower.co.uk](http://www.upspower.co.uk)

Uninterruptible Power Supplies Ltd.  
Woodgate  
Bartley Wood Business Park  
Hook  
Hampshire  
RG27 9XA  
Tel: 01256 386700

Name: .....  
Job Title: .....  
Company: .....  
Address: .....  
.....  
.....  
.....  
.....  
Post Code .....  
Tel. ....  
Fax. ....  
E-mail .....

Please contact me to discuss:

- Extended Warranty options for my PW8000DPA ST UPS
- Extended warranty options for my UPS System as below:
  - Manufacturer:.....
  - Model N°:.....
  - Rating kVA:.....
- Replacement Batteries.....
- Other .....(please specify)

Thank you for your enquiry, which will receive our prompt attention.  
If you need to contact us immediately call free on,  
Freefone 0800 731 3269  
or E-mail us on [service@upspower.co.uk](mailto:service@upspower.co.uk)  
[www.upspower.co.uk](http://www.upspower.co.uk)

# 3 Installation

## 3.1 Introduction

This chapter contains all the information necessary for the correct unpacking, positioning, cabling and installation of the PW8000DPA ST UPS cabinet.



**WARNING:** All the operations described in this section must be performed by authorised electricians or suitably qualified personnel.

Uninterruptible Power Supplies Ltd. will take no responsibility for any personal or material damage caused by incorrect cabling or operations, or activities which are not carried out in strict accordance with the instructions contained in this manual.

## 3.2 Receipt of the UPS

The UPS and accessories are delivered on a specifically designed pallet that is easy to move with a forklift or a pallet jack.



**CAUTION:** When off loading the UPS always keep it in an upright position.

*Do not drop the equipment.*

*Do not stack the pallets due to the high-energy batteries involved and the heavy weight.*

The packing container protects the UPS from mechanical and environmental damage. This protection is further increased by wrapping the PW8000DPA ST UPS with a plastic sheet.

Upon receiving the UPS, carefully examine the packing container and the UPS for any sign of physical damage. The outside 'Tip&Tel' ("FRAGILE" and "ARROW") indicator should be intact if the equipment has been transported in an upright position. In case of rupture (or if they are suspect) inform the carrier and Uninterruptible Power Supplies Ltd immediately.



**CAUTION:** Visible transport damages must be notified to the carrier immediately after receipt!

*Other claims for shipping damage must also be filed immediately and the carrier must be informed within 7 days of receipt of the equipment.*

*Packing materials should be stored for further investigation.*

Ensure that the received UPS corresponds to the description indicated in the delivery note.

### 3.2.1 Site transportation

If you transport the UPS equipment after it has been off-loaded (for example, for storage or moving to a different installation location) please observe the following precautions.



**CAUTION:** Transportation:

*To avoid the UPS cabinets and/or battery cabinet falling over, use the shipping brackets on the rear and front to secure the cabinets.*

*– Do not tilt the cabinets more than 10° from vertical.*



**CAUTION:** Potential dangers:

*– If the cabinet has been tilted it might damage the equipment and it should not therefore be connected to the mains electricity supply.*

*– The weight of the UPS system could cause serious injuries to persons or anything in the surrounding area.*



**CAUTION: Storage:**

- The UPS should be stored in the original packing and shipping carton.
- The recommended storing temperature for the UPS system and batteries is between +5 °C and +40°C.
- The UPS system and the battery sets must be protected from humidity < 90% RH (non-condensing).

### 3.3 Unpacking



**WARNING:** The UPS system, the battery cabinet (option) and the batteries are heavy and may tip during transportation causing serious injury if the unpacking instructions are not followed closely.

If the packages are received in good order (i.e. the 'tip & tell' "FRAGILE" and "ARROW" indications on the packing container are intact) then perform the following steps to unpack the UPS:

1. If the cabinet is shipped inside a wooden case, remove the screws at the base and sides of the case then carefully remove the case from the equipment.
2. Cut the wrappers and remove the packing container by pulling it upwards.
3. Remove the plastic sheeting covering the UPS.
4. Remove the UPS from the pallet.
5. Retain the packaging materials for future shipment of the UPS.
6. Examine the UPS for any sign of damage.  
Notify your supplier immediately if damage is apparent.
7. Open the cabinet door and ensure that all the UPS modules are correctly and securely fitted in their compartments.  
Ensure that a protection cover is fitted to the front of any empty UPS compartments.

#### 3.3.1 Nameplate

The technical specifications of the PW8000DPA ST are provided on the nameplate which is situated at the front (internal door) of the UPS.

Check that the details on the nameplate corresponds to the purchased material detailed on the delivery note.

### 3.4 Batteries

The standard batteries connected to the UPS are sealed, maintenance-free batteries which will be mounted either within the UPS cabinet or an external battery cabinet. The battery will usually be connected when the UPS is commissioned.

Battery life depends very much on the ambient temperature, and optimum battery life will be obtained if the batteries are operated at a temperature of 20°C.

If the UPS is delivered without batteries, Uninterruptible Power Supplies Ltd is not responsible for any damage or malfunctioning caused to the UPS by the incorrect storage, installation or connection of batteries by third parties.



## 3.5 Storage

### 3.5.1 UPS

If you plan to store the UPS prior to use, store it in a clean dry environment with a temperature between +5°C to +40°C and RH of less than 90%. If the packing container is removed, you must protect the UPS from dust.

### 3.5.2 Battery

The UPS utilizes sealed, maintenance-free batteries, whose storage capability depends on ambient temperature. It is therefore important not to store the UPS for longer than 6 months at 20°C, 3 months at 30°C or 2 months at 35°C storage temperature without recharging the batteries. For longer term storage the battery should be fully recharged every 6 months @20°C.



**CAUTION:** Sealed batteries must never be stored in a discharged or partially discharged state. Extreme temperature, under-charge, overcharge or over-discharge will destroy batteries!



**Key Point:** Note the following:

- Charge the battery both before and after storing.
- Always store the batteries in a dry, clean, cool environment in their original packaging.
- If the packaging is removed protect the batteries from dust and humidity.

## 3.6 Positioning

### 3.6.1 Planning the installation

A certain amount of pre-planning will help ensure smooth, trouble-free equipment installation. The following guidelines should be taken into account when planning a suitable UPS location and environment.

1. The equipment must be installed and transported in a upright position.
2. The floor at the installed location and en-route from the off-loading point must be able to safely take the weight of the UPS and battery equipment plus fork lift during transit.
3. The UPS cabinet requires space to bottom/front and back to enable cooling airflow. Suitable ventilation airflow must also be provided (See Figure 3.1). Allow a 200mm minimum clearance at the back of the cabinet.
4. All parts of the UPS required for maintenance, servicing and user operation are accessible from the front. Reserve a minimum of 900mm space at the front of the UPS cabinet.
5. An ambient temperature of 20°C is recommended to achieve a long battery life. The cooling air entering the UPS must not exceed +40°C.
6. Avoid high ambient temperature, moisture and humidity. The floor material should be non-flammable and strong enough to support the heavy load.
7. In summary, the UPS should be located where:
  - a) Humidity (< 90% non-condensing) and temperature (+15°C to +25°C) are within prescribed limits.
  - b) Fire protection standards are respected.
  - c) Cabling can be performed easily.
  - d) A minimum 900mm front accessibility is available for service or periodic maintenance.
  - e) Requested air cooling flow is available.
  - f) The air conditioning system can provide a sufficient amount of air cooling to keep the room at, or below, the maximum desired temperature.
  - g) No dust or corrosive/explosive gases are present.
  - h) The location is vibration free.
  - i) If the UPS will be installed in bayed enclosures, partition walls have to be installed.

### 3: Installation

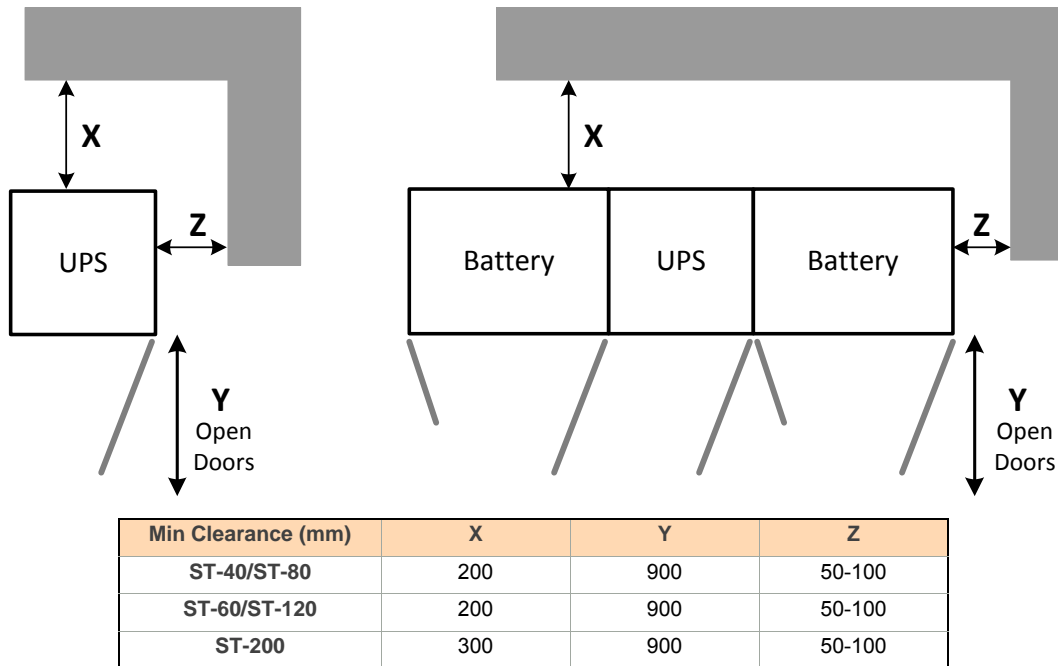

	ST-40	ST-60	ST-80	ST-120	ST-200
Dimensions (WxHxD) mm	550 x 1135 x 770	550 x 1975 x 770	550 x 1135 x 770	550 x 1975 x 770	550 x 1975 x 770
Accessibility	Totally front accessibility for service and maintenance (no side, top or rear access required)				
Positioning	Min. 200 mm rear space (required for ventilation)				300mm rear
Input/Output Power Cabling	From the bottom at the front				

Figure 3.1 UPS Space Recommendations

## 3.7 UPS Power Cabling (preparation and planning)

### 3.7.1 General requirements

It is the customer's responsibility to provide all external fuses, isolators and cables used to connect the UPS input and output power supplies. The information in this section should assist in the planning and preparation of the UPS power cabling.

The UPS input supply and bypass supply should be connected to the utility mains through a LV-Distribution board and protected by a circuit breaker or fuse. This provides overload protection and also a means of isolating the UPS from the mains supply when required. Similarly, the UPS output supply should be connected to the load equipment via a suitably fused output distribution panel.

The UPS can be wired with a 'single feed' input (standard), whereby the UPS input supply is connected internally to the UPS bypass circuit; or it can be wired with a 'dual feed' input, whereby the UPS bypass circuit is connected to a dedicated 'bypass' supply (See Figure 3.3).

Figure 3.3 identifies the UPS input/output cabling requirements and provides information regarding fuse ratings, cable ratings and cable sizing. This information is given for guidance only.



**Key Point:** This information is given for guidance only. All fuses, isolators and power cables must be rated and installed in accordance with the prescribed IEC standards or local regulations – e.g. BS7671:2008.

Figure 3.5 shows details of the power terminal connections with the UPS including connection sizes and recommended tightening torque. This illustration shows that the UPS unit requires the following power cables:

**Rectifier (In):**

- three-phase (1L1, 1L2, 1L3)
- neutral (1N)
- protective earth (PE) connection for the rectifier input

**Bypass (In):**

- three-phase (2L1, 2L2, 2L3)
- neutral (2N)
- protective earth (PE) connection for the bypass if used as 'Dual Feed' input

**Load (Out):**

- three-phase (3L1, 3L2, 3L3)
- neutral (3N)
- protective earth (PE) connection for the load output

**External Battery:**

- Plus (+)
- Common (N)
- Minus (-)
- protective earth (PE) connection for the external batteries

**Input neutral grounding**



**Key Point:** Input neutral is required to operate the rectifier.

In TN-S systems, no 4-pole input switches or circuit breakers should be used.  
 During battery operation the neutral must always be grounded.

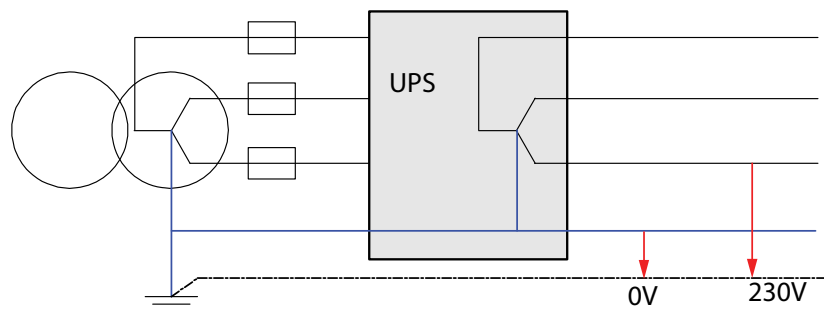
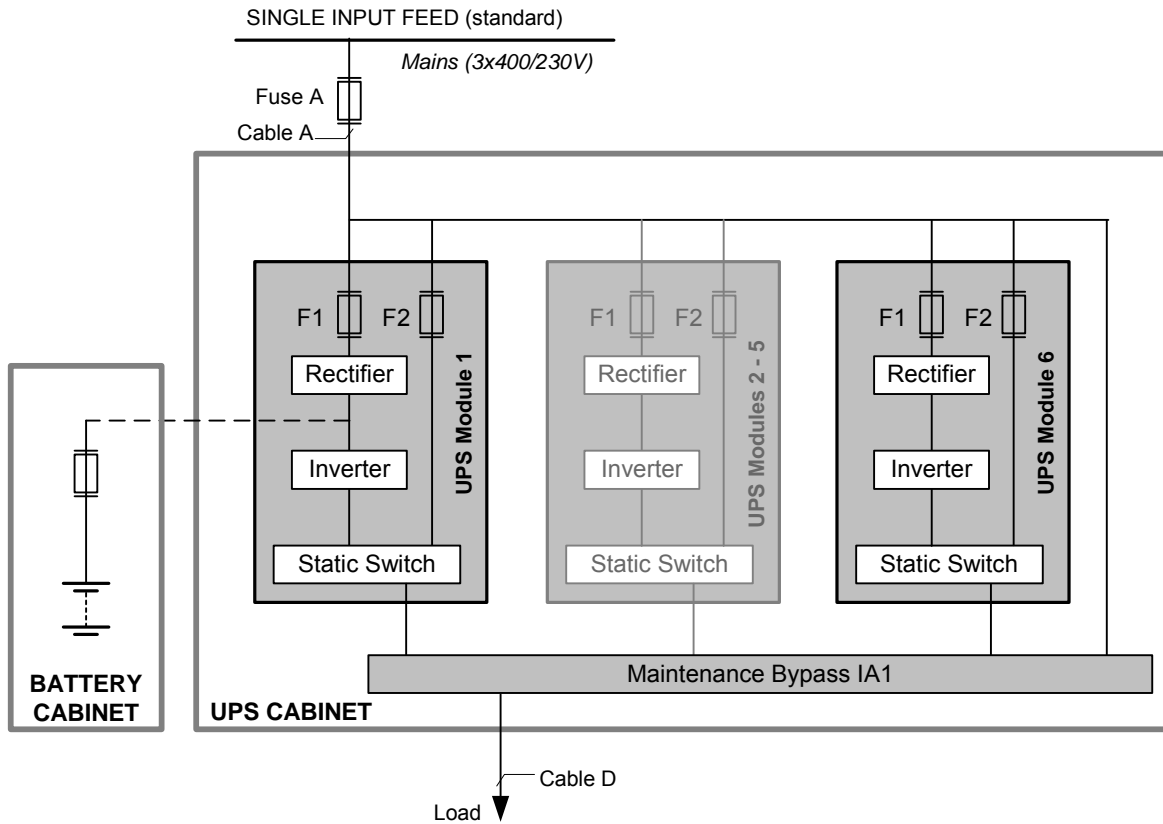

Figure 3.2 Input neutral grounding



**Cabinet Mounted – Single Input Feed**

	Input 3x400V/230V			Output 3x400V/230V	
	Fuse A (Ag/CB)	Cable A (mm <sup>2</sup> )	Max I/P Current	Cable D (mm <sup>2</sup> )	I(nom)
ST-40	3x80A	5x16	68A	5x16	58A
ST-60	3x125A	5x35	102A	5x35	87A
ST-80	3x160A	5x50	136A	5x50	116A
ST-120	3x224A	4x95 + 1x50(PE)	208A	5x70	174A
ST200	3x350A	5x185	333A	5x185	290A

**Notes:**

1. Fuse and Cable recommendations to IEC 60950-1:2001.
2. The fuse and cable rating details in the above tables are a recommendation only.
3. The UPS must be installed to prescribed IEC or local regulations (e.g. BS7671:2008).
4. DC Cables and Battery fuses are bespoke to the installation.

Figure 3.3 PowerWAVE 8000DPA ST fuse & cable rating for single input supply

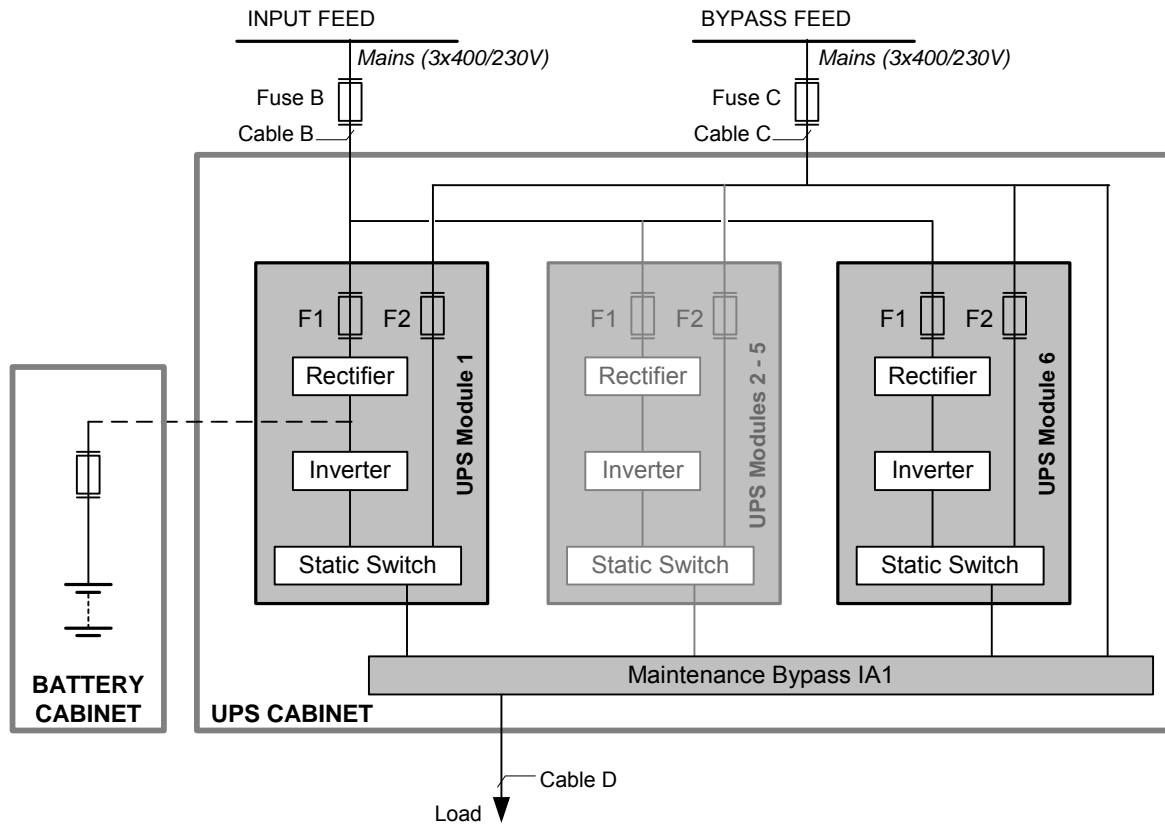

**Cabinet Mounted – Dual Input Feed**

	Input 3x400V/230V			Input 3x400V/230V		Output 3x400V/230V	
	Fuse B (Agl/CB)	Cable B (mm <sup>2</sup> )	Max I/P Current	Fuse C (Agl/CB)	Cable C (mm <sup>2</sup> )	Cable D (mm <sup>2</sup> )	I (nom)
ST-40	3x80A	5x16	68A	3x80A	4x16	5x16	58A
ST-60	3x125A	5x35	102A	3x125A	4x35	5x35	87A
ST-80	3x160A	5x50	136A	3x160A	4x50	5x50	116A
ST-120	3x224A	4x95 + 1x50(PE)	208A	3x224A	4x95	5x70	174A
ST200	3x250A	5x185	333A	3x350A	4x185	5x185	290A

**Notes:**

1. Fuse and Cable recommendations to IEC 60950-1:2001.
2. The fuse and cable rating details in the above tables are a recommendation only.
3. The UPS must be installed to prescribed IEC or local regulations (e.g. BS7671:2008).
4. DC Cables and Battery fuses are bespoke to the installation.

Figure 3.4 PowerWAVE 8000DPA ST fuse & cable rating for dual input supply

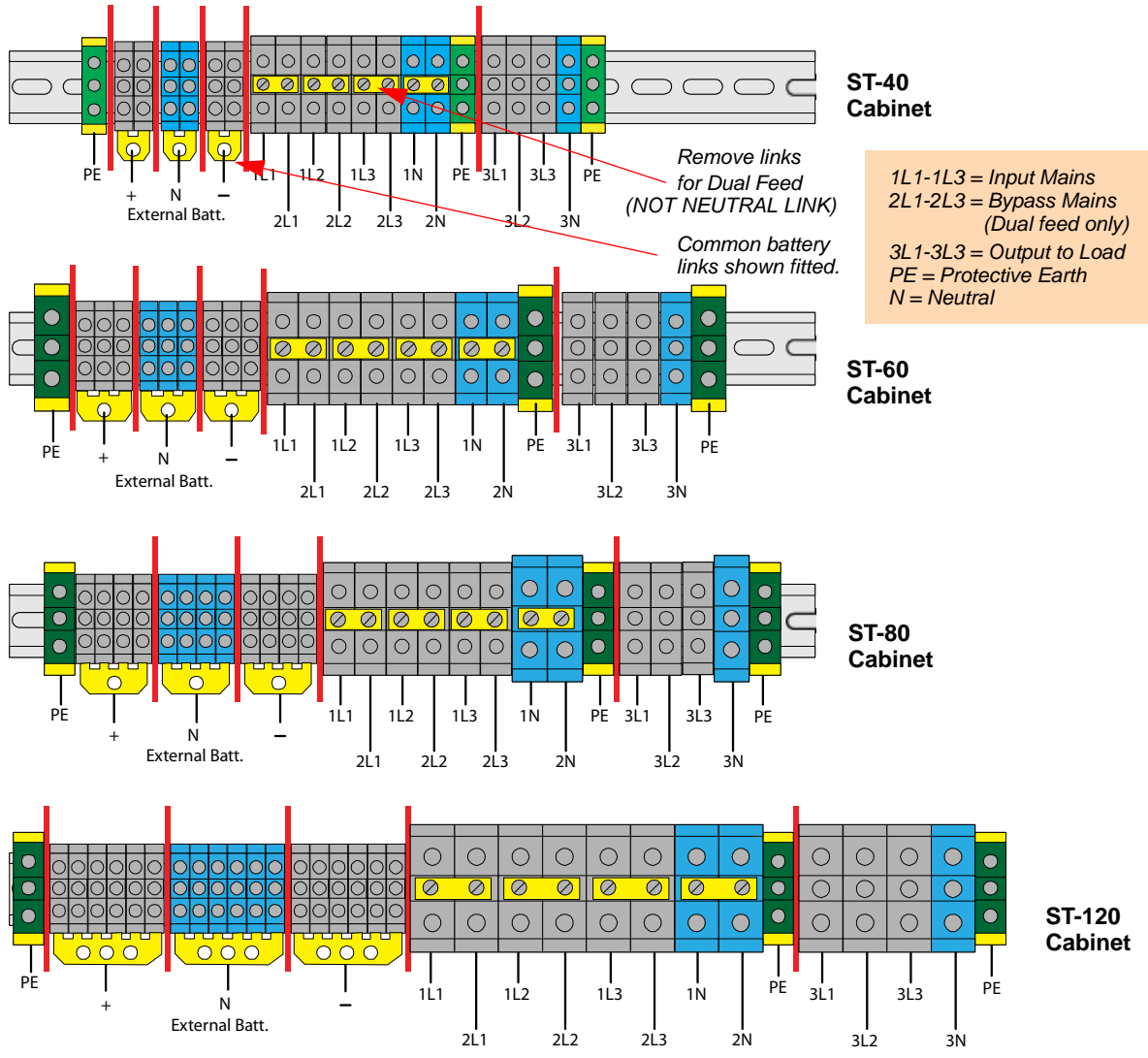

UPS Range	Common Battery (+ / N / -)	Input Bypass (3+N)	Input Rectifier (3+N+PE)	Output Load (3+N+PE)
ST-40	3 x M5 (B)	4 x 16/25mm <sup>2</sup> (T)	5 x 16/25mm <sup>2</sup> (T)	5 x 16/25mm <sup>2</sup> (T)
ST-60	3 x M6 (B)	4 x 35 <sup>2</sup> (T)	4 x 35 <sup>2</sup> (T) + PE 50 <sup>2</sup> (T)	4 x 35 <sup>2</sup> (T) + PE 50 <sup>2</sup> (T)
ST-80	3 x M6 (B)	4 x 50 <sup>2</sup> (T) + N 70/95mm <sup>2</sup> (T)	3 x 50 <sup>2</sup> (T) + N 70/95mm <sup>2</sup> (T) + PE 50mm <sup>2</sup> (T)	3 x 50 <sup>2</sup> (T) + N 70/95mm <sup>2</sup> (T) + PE 50 <sup>2</sup> (T)
ST-120	3 x 2xM5 (B) or 3 x M10 (B)	4 x 70/95mm <sup>2</sup> (T)	4 x 70/95mm <sup>2</sup> (T) + PE 50 <sup>2</sup> (T)	4 x 70/95mm <sup>2</sup> (T) + PE 50 <sup>2</sup> (T)

**Notes:**

1. Fuse and Cable recommendations to IEC 60950-1:2001.
2. The fuse and cable rating details in the above tables are a recommendation only.
3. The UPS must be installed to prescribed IEC or local regulations (e.g. BS7671:2008).
4. DC Cables and Battery fuses are bespoke to the installation.

Figure 3.5 ST-40, ST-60, ST-80, ST-120 Power cable and connection sizes

**ST-200  
Cabinet**

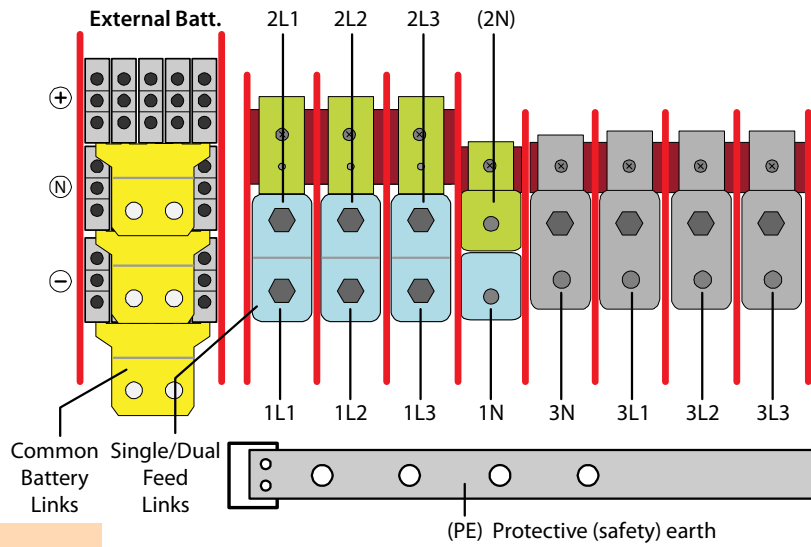

1L1-1L3 = Input Mains  
2L1-2L3 = Bypass Mains (Dual feed only)  
3L1-3L3 = Output to Load  
PE = Protective Earth  
N = Neutral

Remove links for separate battery installation and connect batteries to individual terminals.  
Note that when using individual batteries, each battery is connected to two UPS modules.

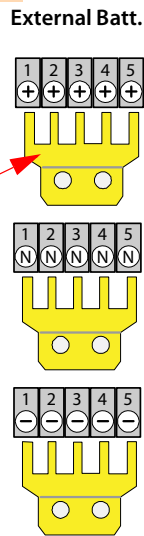

**Bypass Mains Supply (Dual input feed only)**

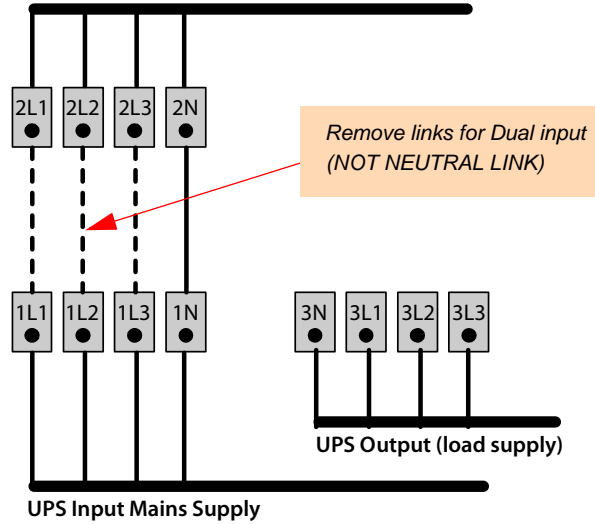

UPS Range	Separate Battery	Common Battery (+ / N / -)	Input Bypass (3+N)	Input Rectifier (3+N+PE)	Output Load (3+N+PE)
ST-200	5 x 35 <sup>2</sup> (T) 1 batt feeds 2 modules	3 x (2 x M10) (B) +PE 1 x M10 (B)	3 x M12 (B) +PE 1 x M12 (B)	4 x M12 (B) +PE 1 x M12 (B)	4 x M12 (B) +PE 1 x M12 (B)

**Notes:**

1. Fuse and Cable recommendations to IEC 60950-1:2001.
2. The fuse and cable rating details in the above tables are a recommendation only.
3. The UPS must be installed to prescribed IEC or local regulations (e.g. BS7671:2008).
4. DC Cables and Battery fuses are bespoke to the installation.

**Figure 3.6 ST-200 Power cable and connection sizes**

### 3.8 Connecting the UPS input supply



**WARNING:** Opening or removing the UPS enclosure covers will create the risk of exposure to dangerous voltages if power is connected to the UPS.

#### 3.8.1 Safety notes

Please ensure you read and understand the following safety notes before you begin the UPS electrical installation.

1. All operations detailed in this section must be performed by an authorised electrician or qualified personnel.
2. Once the electrical installation is completed the initial UPS start-up and commissioning must be performed by qualified personnel authorised by the manufacturer.
3. Do not operate the UPS if there is water or moisture present.
4. When carrying out any work on the UPS input power cables you must ensure that the UPS supplies are isolated at the supply distribution panel and, where possible, locked out. Warning notices should be posted where applicable to prevent inadvertent operation of the input supply isolators.

#### 3.8.2 Preparing the input cabling

Before you start connecting the UPS input cables:

- Ensure that the provided fuses and cables satisfy the ratings shown in Figures 3.3 to 3.5, and are in accordance with the prescribed IEC Standards or local regulations (e.g. BS7671:2008).
- Do not commence this procedure until the UPS is properly installed at its intended final location.

#### 3.8.3 Connecting the UPS input power cables

1. To protect personnel during the UPS installation ensure that the connections are performed under the following conditions:
  - a) No mains voltage is present.
  - b) Loads are shut down and disconnected.
  - c) The UPS is shut down and voltage-free.
  - d) The UPS Maintenance Bypass Isolator IA1 is OFF.
2. Gain internal access to the UPS and remove the UPS terminal cover.
3. Connect the earth cable from the LV-Distribution Board to the protective earth (PE) terminal in the UPS.
4. The PW8000DPA ST input supply can be wired for 'single feed' (standard) or 'dual feed' operation. Connect the input power cable coming from the LV-Distribution Board to the UPS input terminals following the appropriate instructions (single feed) or (dual feed) below.

##### Single Input Feed

Refer to the schematic drawing and connection table in Figure 3.7.

1. Connect the UPS input supply cables to terminals 1L1, 1L2, 1L3 and 1N on the UPS main terminal block (See Figure 3.5). Ensure correct (clockwise) phase rotation.



**CAUTION:** The input Neutral cable must ALWAYS be connected.

2. Secure the cables to the fixing rail located under the UPS connection terminals.



### Dual Input Feed

Refer to the schematic drawing and connection table in Figure 3.8.

1. The UPS is supplied (as standard) with facilities for a single cable feed for the rectifier and bypass supplies. For a dual feed configuration remove the links between 1L1 - 2L1; 1L2 - 2L2; and 1L3 - 2L3 on the Input Terminal Block (See Figure 3.5). Leave the Neutral link connected between 1N - 2N.
2. Connect the UPS input supply cables to terminals 1L1, 1L2, 1L3 and 1N on the UPS main terminal block (See Figure 3.5). Ensure correct (clockwise) phase rotation.



**CAUTION:** The input Neutral cable must ALWAYS be connected.

3. Connect the UPS bypass supply cables to terminals 2L1, 2L2, 2L3 and 2N on the UPS main terminal block (See Figure 3.5). Ensure correct (clockwise) phase rotation.



**CAUTION:** The bypass Neutral cable must ALWAYS be connected.

4. Secure the cables to the fixing rail located under the UPS connection terminals.

**Note:** The UPS commissioning engineer will configure the UPS system for a dual input operation at the time of commissioning.

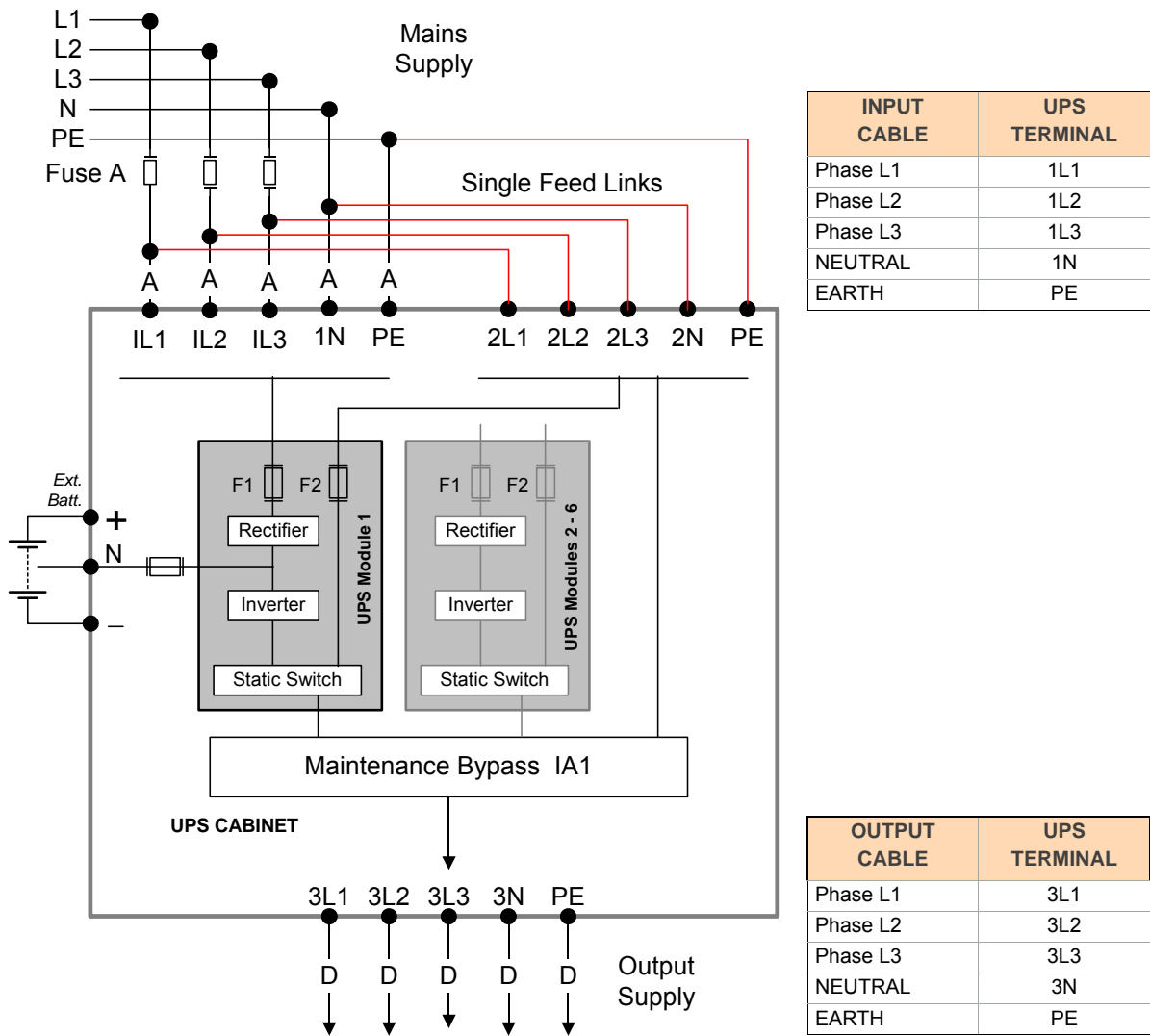

	Fuse A (A)	Cable A (mm <sup>2</sup> )	Cable D (mm <sup>2</sup> )
ST-40	3 x 80	5 x 16	5 x 16
ST-60	3 x 125	5 x 35	5 x 35
ST-80	3 x 160	5 x 50	5 x 50
ST-120	3 x 224	4x95 +1x50(PE)	5 x 70
ST200	3x350	5 x 185	5 x 185

Fuse and Cable recommendations to IEC 60950-1:2001  
 The fuse and cable rating details in the above tables are a recommendation only.  
 The UPS must be installed to prescribed IEC or local regulations (e.g. BS7671:2008)

Figure 3.7 UPS with Single Input Feed - Connection block diagram

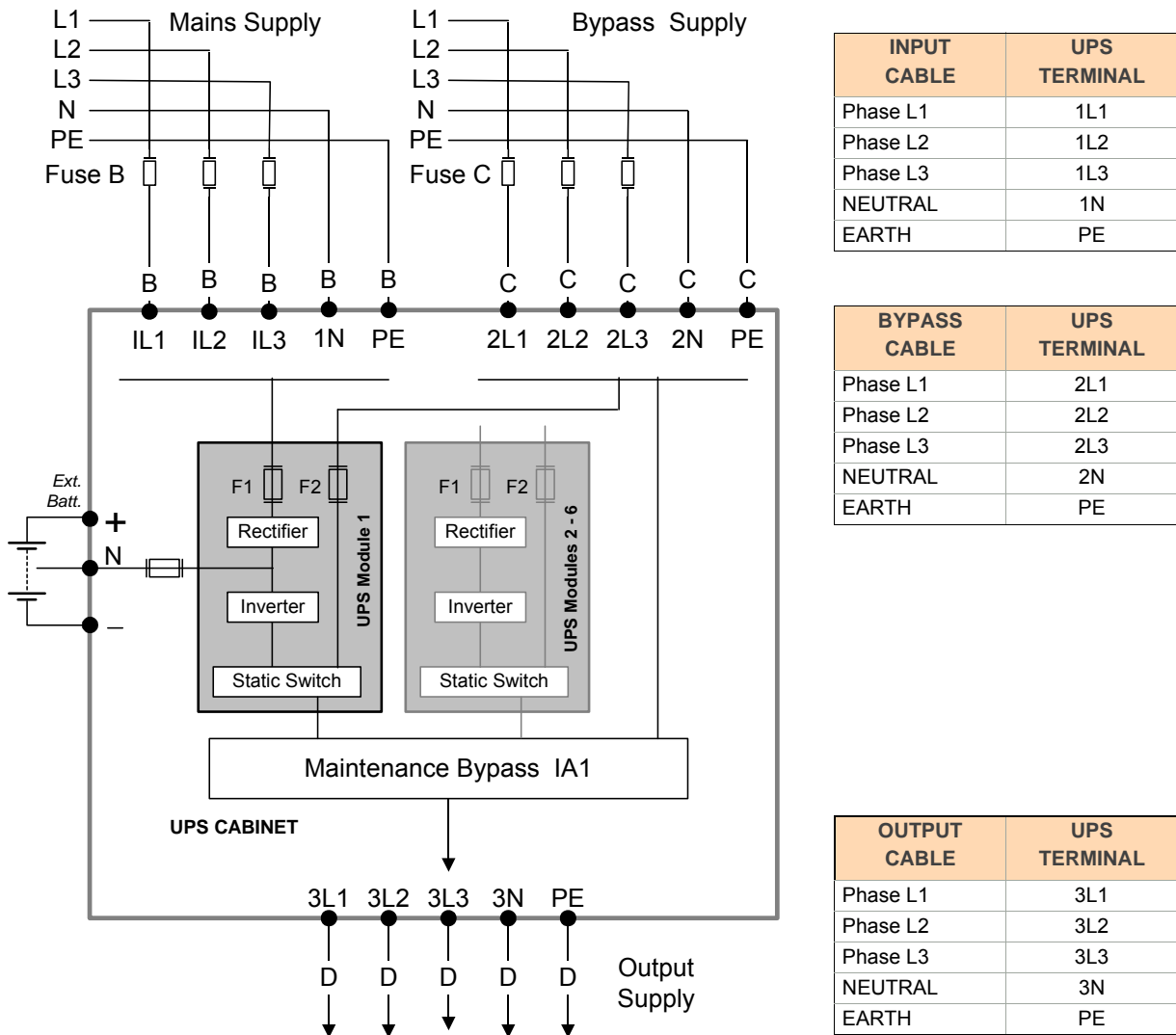

	Fuse B (A)	Cable B (mm <sup>2</sup> )	Fuse C (A)	Cable C (mm <sup>2</sup> )	Cable D (mm <sup>2</sup> )
ST-40	3 x 80	5 x 16	3 x 80	4 x 16	5 x 16
ST-60	3 x 125	5 x 35	3 x 125	4 x 35	5 x 35
ST-80	3 x 160	5 x 50	3 x 160	4 x 50	5 x 50
ST-120	3 x 224	4x95 +1x50(PE)	3 x 224	4 x 95	5 x 95
ST200	3 x 350	5 x 185	3 x 350	4 x 185	4 x 185

Fuse and Cable recommendations to IEC 60950-1:2001  
The fuse and cable rating details in the above tables are a recommendation only.  
The UPS must be installed to prescribed IEC or local regulations (e.g. BS7671:2008)

Figure 3.8 Dual Input Feed - Connection block diagram

### 3.9 Connecting the UPS Output Supply



**WARNING:** Opening or removing the UPS enclosure covers will create the risk of exposure to dangerous voltages if power is connected to the UPS.

#### 3.9.1 Safety notes

Ensure you read and understand the following safety notes before you begin the UPS electrical installation.

1. All operations detailed in this section must be performed by an authorised electrician or qualified personnel.
2. Once the electrical installation is completed the initial UPS start-up and commissioning must be performed by qualified personnel authorised by the manufacturer.
3. Do not operate the UPS if there is water or moisture present.
4. When carrying out any work on the UPS output power cables you must ensure that the UPS supplies are isolated at the supply distribution panel and, where possible, locked out. Warning notices should be posted where applicable to prevent inadvertent operation of the input supply isolators.

#### 3.9.2 Preparation for the output cabling

Circuit breakers (or equivalent protection) must be fitted between the UPS output and load equipment to provide additional protection to the UPS in the event of an overload or short circuit, and also provide a means of isolating individual loads if required.

Before you start connecting the UPS output cables to the load distribution panel:

- Ensure that the potential load does not exceed the UPS model output power rating (OUTPUT POWER) on the nameplate.
- Ensure the output circuit breakers are correctly sized with respect to the load rating and associated cabling.
- The maximum total load rating and maximum load rating of the individual load sockets should be indicated on the output distribution board.
- The circuit breakers must comply with the prescribed IEC Standards (e.g. BS7671:2008). It is recommended that a separate output distribution board is provided for the load.

#### 3.9.3 Connecting the UPS output cables

1. To protect personnel during the UPS installation ensure that the connections are performed under the following conditions:
  - a) No mains voltage is present.
  - b) Loads are shut down and disconnected.
  - c) The UPS is shut down and voltage-free.
  - d) The UPS Maintenance Bypass Isolator IA1 is OFF.
2. Gain internal access to the UPS and remove the UPS terminal cover.
3. Connect the protective earth cable from the Load Distribution Board to the output protective earth (PE) terminals, as shown in Figure 3.5.
4. Connect the UPS output supply cables to terminals 3L1, 3L2, 3L3 and 3N on the UPS main terminal block (See Figure 3.5). Ensure correct (clockwise) phase rotation.



**CAUTION:** The output Neutral cable must ALWAYS be connected.

5. Secure the cables to the fixing rail located under the UPS connection terminals.
6. Ensure the output cables are connected to the correct power terminals on the output (load) distribution panel.

### 3.10 Connecting the batteries

#### 3.10.1 Safety Notes



**WARNING:** Opening or removing the UPS enclosure covers will create the risk of exposure to dangerous voltages if power is connected to the UPS.

The final assembly and connection of the battery units must be carried out by the commissioning engineer. Do not attempt to complete the battery wiring or close the battery isolators before this system has been commissioned.

1. For personal protection, ensure that the battery cables are connected under the following conditions:
  - a) No mains voltage is present in the UPS.
  - b) All the loads are disconnected.
  - c) The UPS battery isolators are open and the external battery isolators are open in the external battery cabinet (where used) – i.e. the terminals to which the battery cables are to be fitted are electrically isolated.

#### 3.10.2 Battery cabling

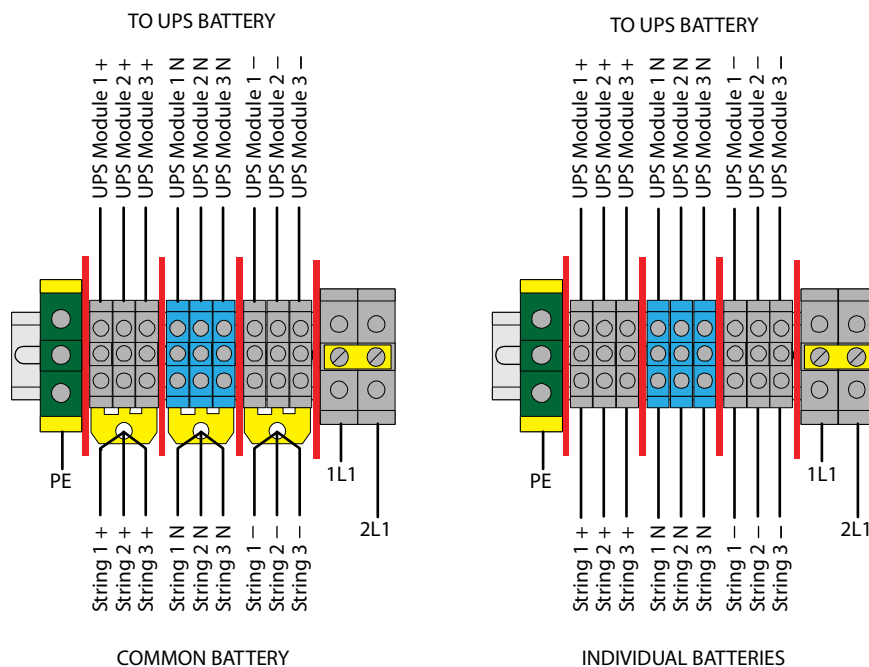

**Figure 3.9** Battery connections (ST-60 Cabinet shown)

In all modules, the batteries are connected to terminal blocks mounted on the left hand side of the power connection rail – as shown in Figure 3.5. There are three terminal block connections for each UPS module, annotated Battery + / N / –. The cables at the top of these terminal blocks are connected to the battery isolators associated with each individual UPS module. The battery strings are connected to the bottom of the terminal blocks, as shown in Figure 3.9.

*Note:* Figure 3.9 depicts the ST-60 Cabinet, which houses (up to) three UPS modules.

#### Battery configuration options

Several battery configurations are possible, depending on the required load power and battery autonomy time. Several examples are shown in the following diagrams.

#### Common battery configuration

Where a ‘common battery’ configuration is implemented, all the UPS modules are fed by a common battery source (which may comprise a number of parallel battery strings). Where this type of installation is used, ‘common battery’ links must fitted to the bottom of the battery connection terminal blocks as shown in the left-hand diagram of Figure 3.9.

### 3.10.3 Connecting the battery cables



**WARNING:** This procedure must be carried out by (or under the supervision of) the system commissioning engineer.

1. Ensure that the UPS input/bypass supply isolators/fuses are open on the input distribution board and verify that no power is being fed to the UPS.
2. Ensure that the MAINTENANCE BYPASS isolator (IA1) is open (OFF).
3. Ensure that the battery isolators within the UPS cabinet are open.
4. If connecting wiring to an external battery cabinet (or racks):
  - a) Ensure that the fused battery isolators in the external battery cabinet (or racks) are open.
  - b) Connect the protective earth cable (PE) between the UPS and external battery cabinet.
  - c) Connect the battery cables, ensuring the cables are connected to the corresponding + / N /- terminals.
5. If connecting the internal batteries (ST-40 and ST-60 cabinet):
  - a) Connect the batteries to the battery connection terminal blocks ensuring the cables are connected to the corresponding + / N /- terminals.

*Note: DC Cables and battery fuses are bespoke to the installation.*

### 3.10.4 Internal battery for ST-40 and ST-60 cabinets

The ST-40 and ST-60 cabinets are designed to house 80 and 240 internal 12V (7/9Ah) battery blocks respectively.

Different battery configurations are shown below.

For details of the battery connections see Figure 3.5 and Figure 3.9.

#### Important notes:

- When the cabinets are populated with 10kVA UPS modules the 12V batteries can be connected in strings of 24-50 (even numbers only), depending the power sourced on the output.
- When the cabinets are populated with 20kVA UPS modules the 12V batteries can be connected in strings of 36-50 (even numbers only), depending the power sourced on the output.
- The commissioning engineer will program the correct number of battery blocks into the UPS control system (using the control panel Service-Set-Up menu) when the system is commissioned.

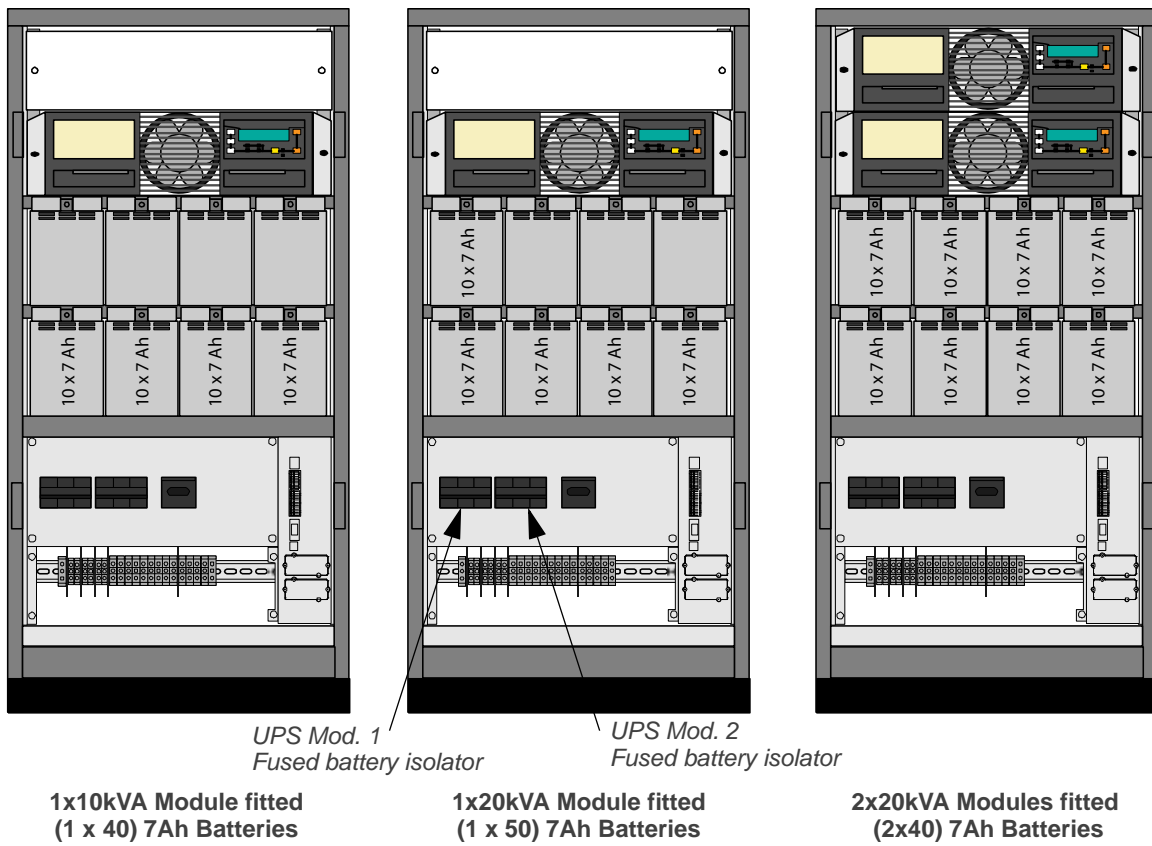

Figure 3.10 ST-40 Cabinet internal battery configuration

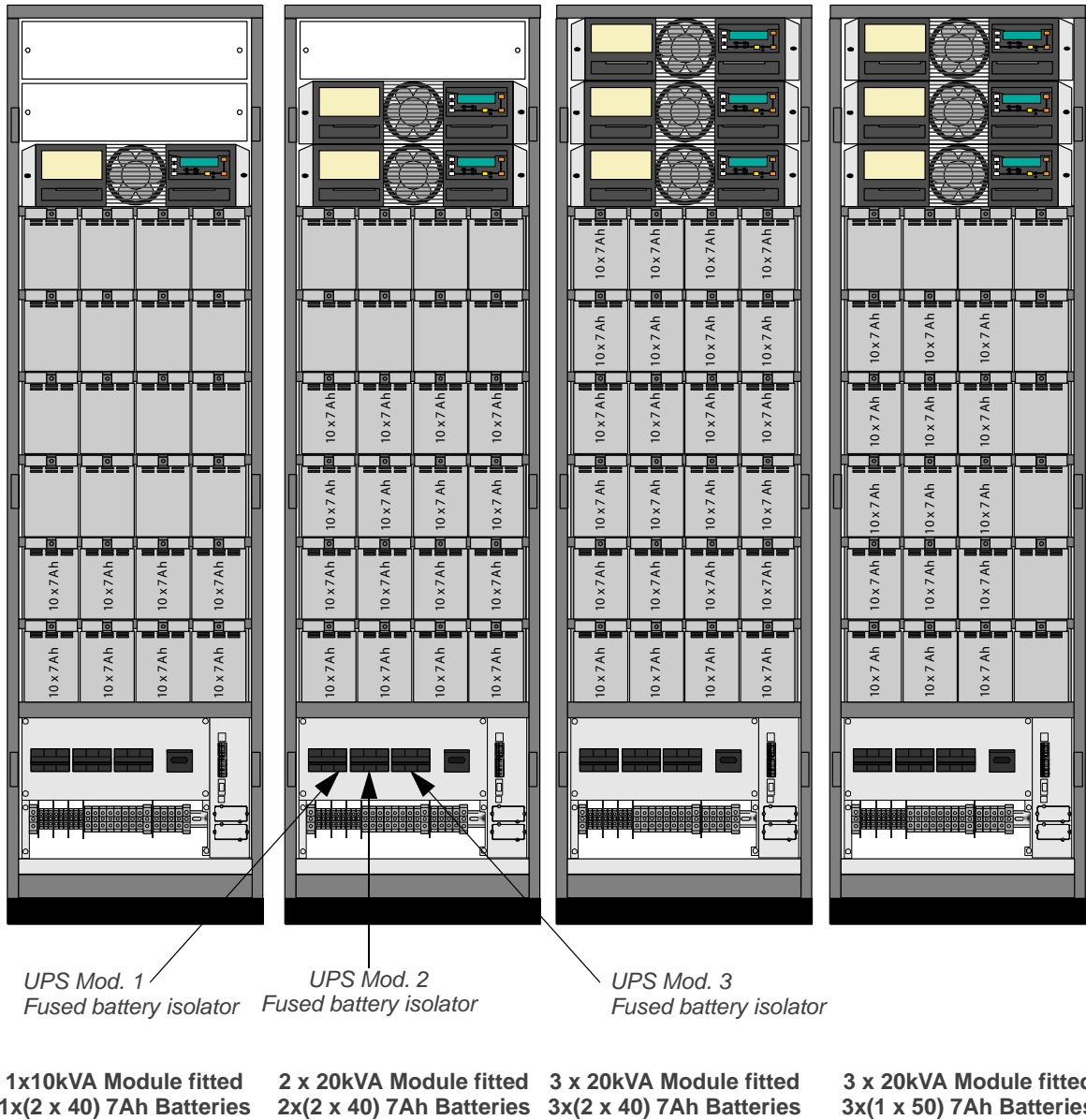

Figure 3.11 ST-60 Cabinet internal battery configuration

### 3.10.5 External battery enclosures

The ST-40 and ST-60 cabinets have integral battery storage; however this is not possible with the ST-80, ST-120 and ST-200 units due to the space required to house a battery of a suitable size. In the case of ST-80 and ST-120 systems the battery is either contained in an external battery cabinet, or rack-mounted.

A range of bespoke battery enclosures designed specifically to suit individual site requirements can be supplied for the ST-80 and ST-120 models – two typical examples are shown in Figure 3.12. In all cases, the battery enclosure is fitted with suitably rated fused isolators which are connected to the battery connection terminals inside the PW8000DPA ST as shown in Figure 3.5.

*Note: DC fuses and cables are bespoke to the installation.*



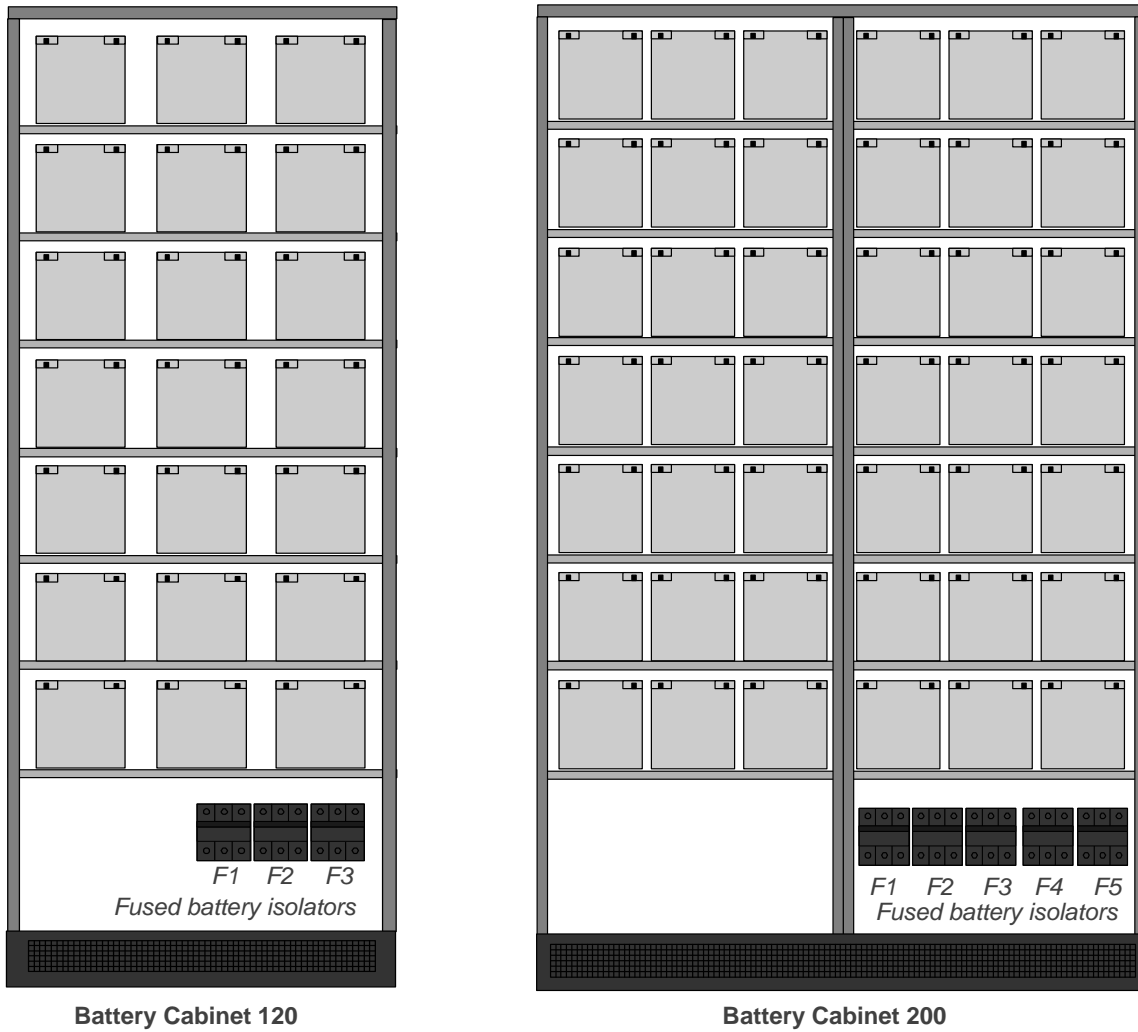
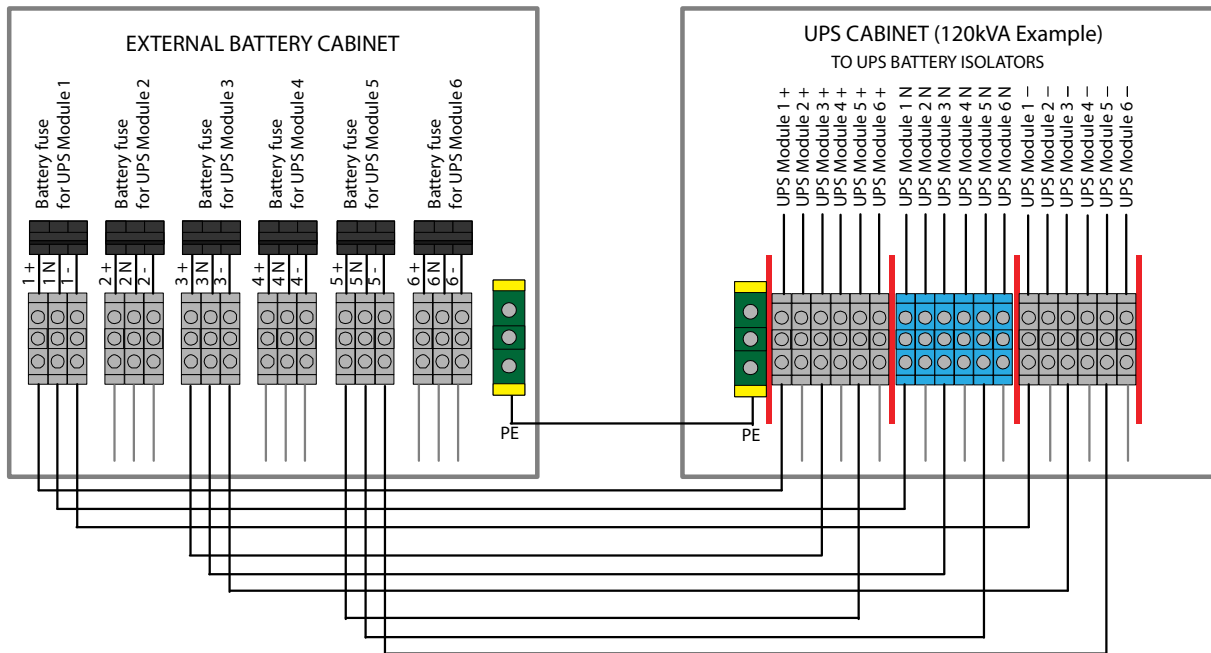
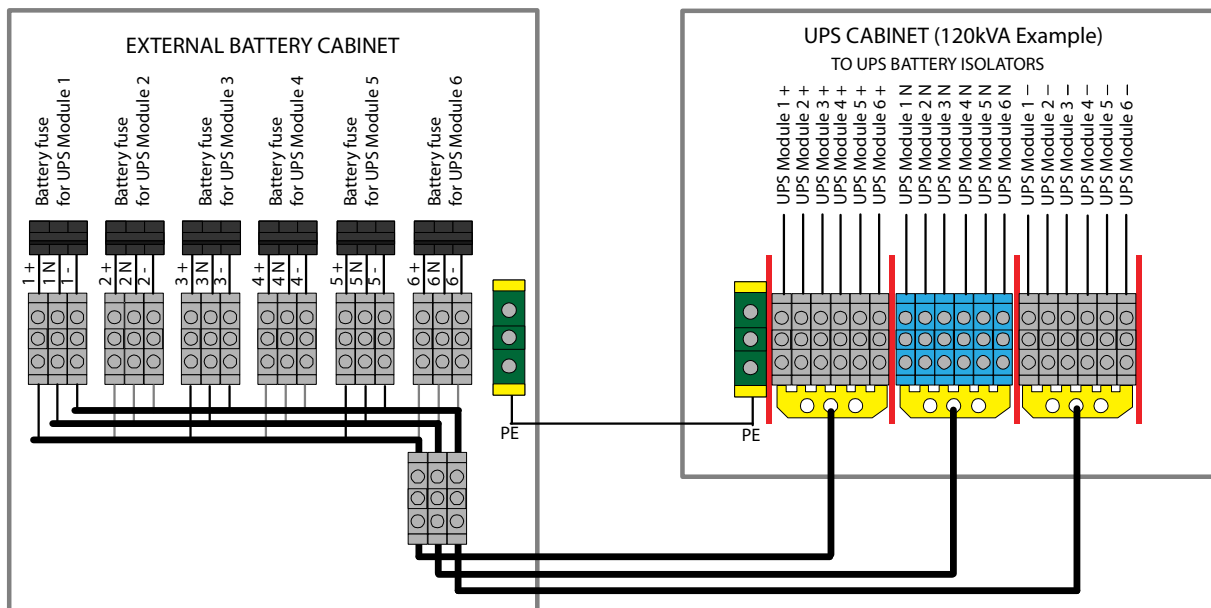

Figure 3.12 External battery cabinets

### 3: Installation



For reasons of clarity, the wiring for modules 1,3,5 only is shown in detail



**Figure 3.13 External battery cabinet connection (ST-120 Cabinet shown)**

Figure 3.13 shows typical methods for connecting the UPS cabinet (ST-120 in the example) to an external battery installation. The top diagram illustrates connection for an ‘individual battery’ installation, and the lower diagram shows a ‘common battery’ installation.

A similar connection diagram for the ST-200 cabinet is shown in Figure 3.14. Note that the ST-200 cabinet only contains connections for five external battery strings, however each connection is wired to the battery circuit breakers of two UPS modules. Therefore where an ‘individual battery’ configuration is used with the ST-200 each battery is in fact connected to 2 UPS modules, rather than an individual module as is the case for the lower powered cabinets.

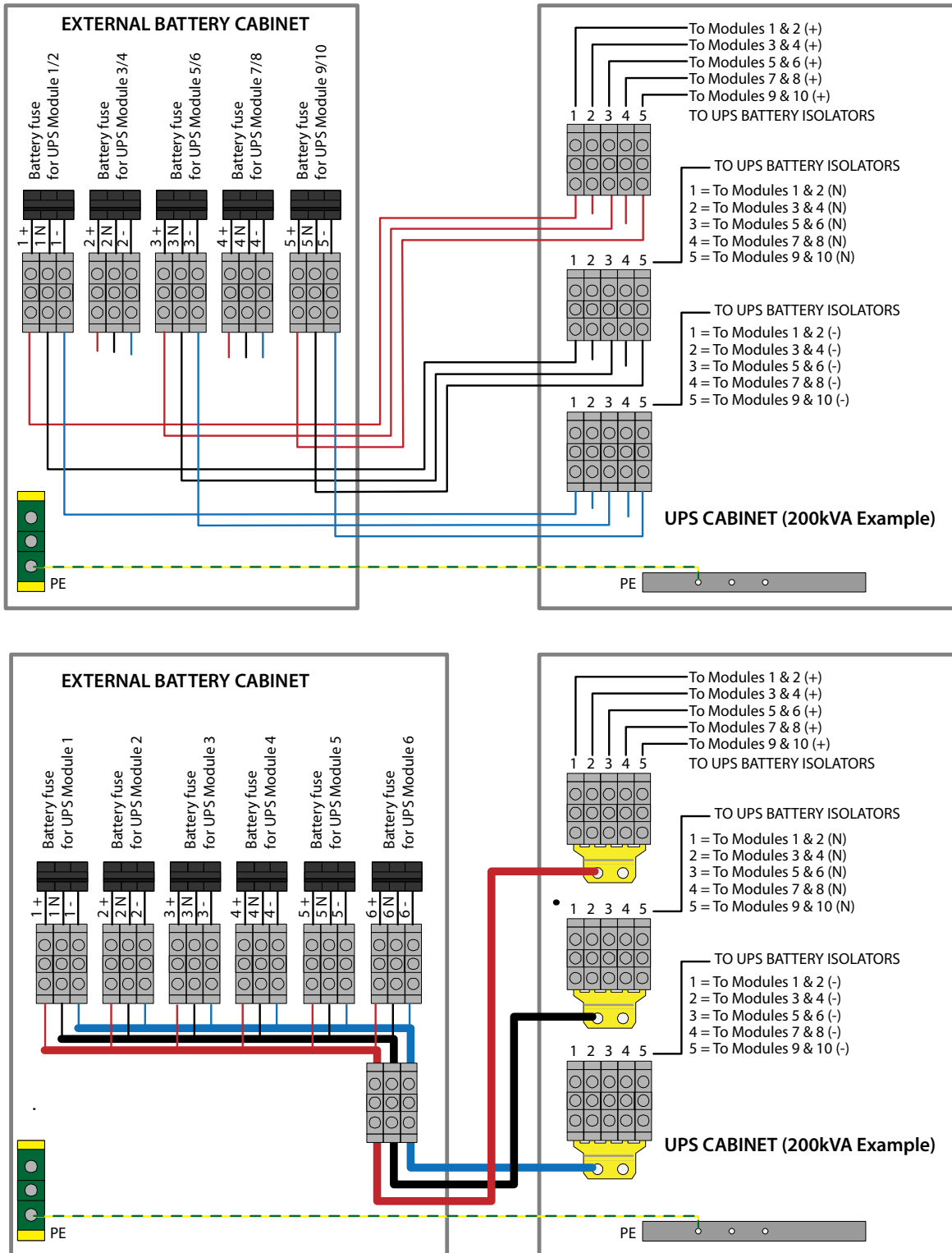
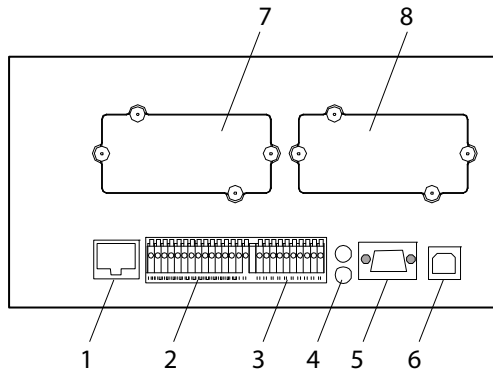

Figure 3.14 External battery cabinet connection for ST-200 cabinet

### 3.11 Module interfacing facilities



1	JR2 (RS485)	Not used.
2	X2	Customer interface on Phoenix Terminals (potential-free contacts).
3	X1	Customer inputs.
4	LEDs	Interface Board Status LEDs.
5	JD1 (RS232)	Sub D9 female, PC Interface.
6	USB	PC Interface.
7	SLOT 2	PowerReporter Slot for optional modem/ethernet card only.
8	SLOT 1	Slot for optional SNMP card only.

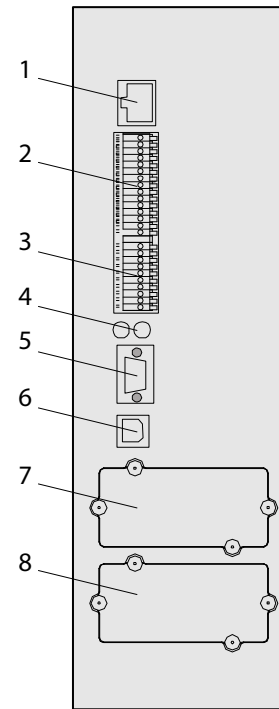

Figure 3.15 UPS Interfacing connectors (ST40 - ST120)

The PW8000DPA ST system contains a communications card which provides various I/O interface facilities. Two LEDs (4) located on the board provide indication of the board's status:

- Green LED – blinking twice per second indicates normal operation.
- Red LED – board alarm (indicates possible board replacement when lit).

#### 3.11.1 Smart Port JD1 (Serial RS 232) and USB Port

The SMART PORT is an intelligent RS 232 serial port that allows the UPS to be connected to a computer. The connector is a standard D-Type, 9-pin, female, and the USB is a standard USB port.

When installed, the optional SMART PORT software, WAVEMON, this connection allows the computer to monitor the mains voltage and the UPS-status continuously and display a message in the event of any UPS system changes.

Figure 3.16 and show the connection to a PC from the UPS for PC's with a 9 pin serial port and 25 pin serial port respectively.

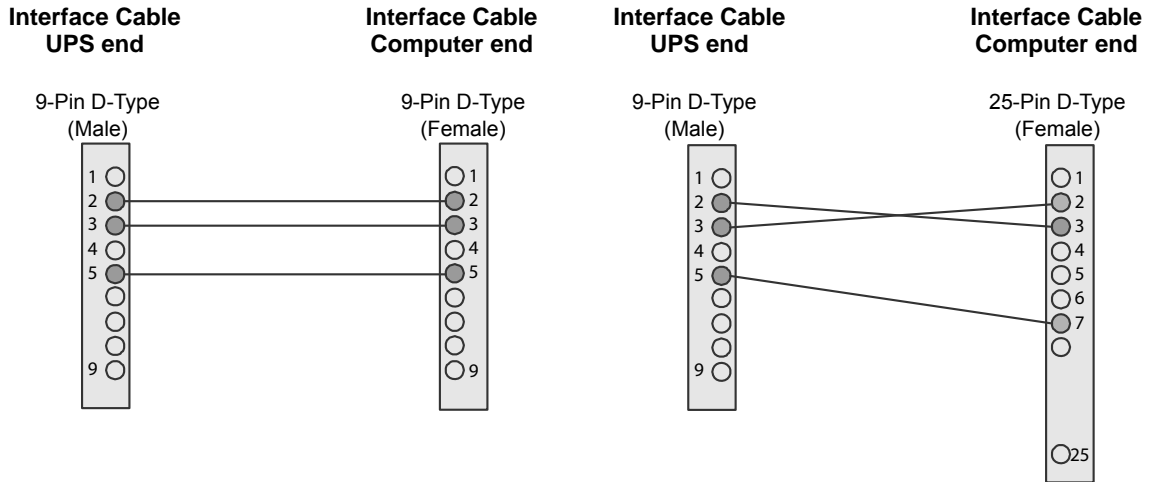

Figure 3.16 Connector Cable - PC Serial Port

### 3.11.2 X1 & X2 Dry Port (volt-free contacts)

All the Input and Output interfaces are connected to Phoenix terminals (cable 0.5 mm<sup>2</sup>)

#### Input Interfaces Terminal block X1

Connection of Remote Shut down facilities, Generator Operation, Customers specials (see also OPTIONS section).

Terminal	Contact	Signal	Function
X1/1	IN ← ○	+12Vdc	Customer IN 1 (default as ONGENERATOR operation) (NC = Generator ON)
X1/2	GND ● ○	Gnd	
X1/3	IN ← ○	+12Vdc	Customer IN 2 (Function on request, to be defined on purchase)
X1/4	GND ● ○	Gnd	
X1/5	IN ← ○	+3.3Vdc	Battery Temperature If connected, the battery charger current is temperature dependent
X1/6	GND ● ○	Gnd	
X1/7	IN ← ○	+12Vdc	Remote shutdown Do not remove the factory mounted bridge until an external remote shut down is connected
X1/8	GND ● ○	Gnd	
X1/9	OUT ○ →	+12Vdc	12Vdc source Max 200mA load
X1/10	GND ● ○	Gnd	

**Output Interfaces Terminal blocks X2 (DRY PORTS)**

Provision of signals for the automatic and orderly shutdown of servers, AS400 or Automation building systems. All voltage free contacts are rated 60 VAC max. and 500 mA max.:

Pin	Contact	Signal	Function
X2/1		Alarm	MAINS_OK
X2/2			Mains Present
X2/3			Mains Failure
X2/4		Message	LOAD_ON_INV
X2/5			Load On Inverter
X2/6			(Load on bypass)
X2/7		Alarm	BATT_LOW
X2/8			Battery Low
X2/9			Battery OK
X2/10		Message	LOAD_ON_MAINS
X2/11			Load On Mains (BYPASS-MODE)
X2/12			(Load on Inverter)
X2/13		Alarm	COMMON_ALARM
X2/14			Common Alarm
X2/15			No Alarm Condition
			Common

Figure 3.17 Dry Port (X2) Connections

# 4 Operation

## 4.1 Commissioning

The PW8000DPA ST UPS is a high quality, complex electronic system that must be commissioned by a fully trained and authorised Uninterruptible Power Supplies Ltd. field service engineer before it is put into use.

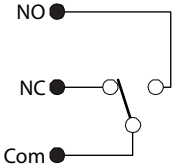
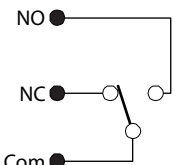
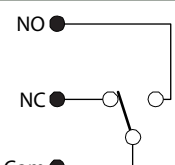
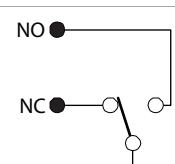
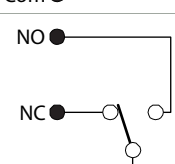
The commissioning engineer will:

- Connect the UPS battery.
- Check the UPS electrical installation and operating environment.
- Perform a controlled UPS start-up.
- Fully test the UPS system for correct operation and set-up.
- Carry out operator training.



**WARNING:** Any PW8000DPA ST UPS system not commissioned by an Uninterruptible Power Supplies Ltd approved engineer must be considered as an electrical hazard, and Uninterruptible Power Supplies Ltd. will accept no responsibility for its safe operation or the safety of any operating personnel. Furthermore, the manufacturer's warranty will be invalidated immediately if the UPS is powered-up or used before it has been correctly commissioned.

## 4.2 UPS control panel

Figure 4.1 illustrates the control panel located on the front of each UPS module.

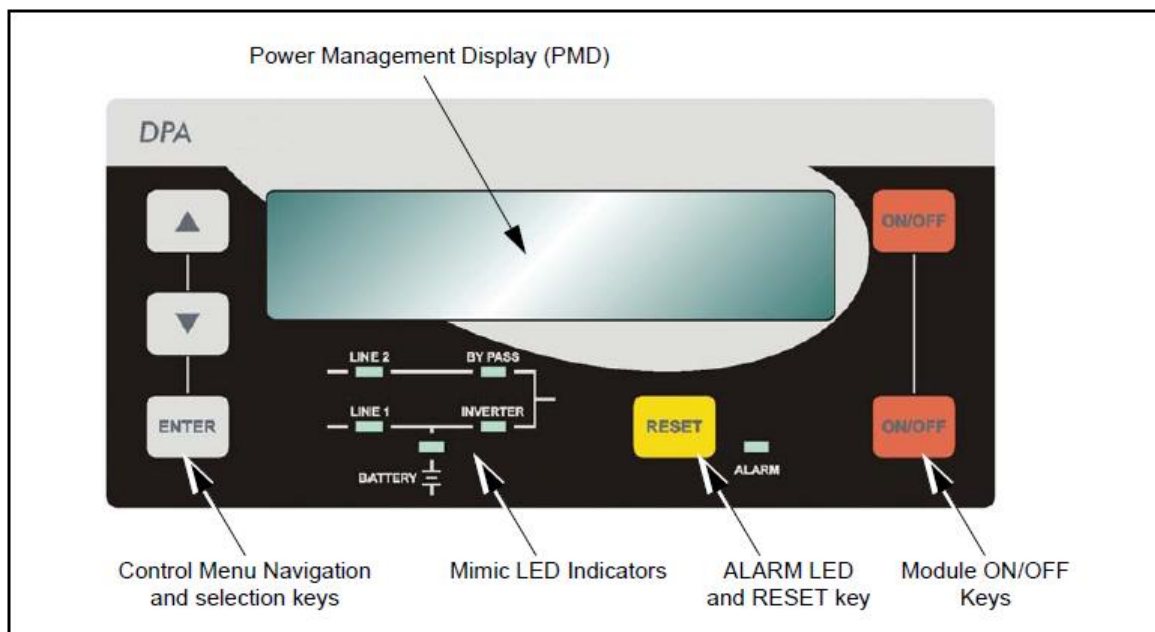

Figure 4.1 UPS control panel

### 4.2.1 Power Management Display (PMD)

The 2 x 20 character LCD Power Management Display simplifies communication with the UPS and also provides UPS monitoring information (See paragraph 4.3).

The menu driven LCD enables the operator to:

- Access the 'event register'.
- Monitor the input and output voltage, current, frequency & power.
- Monitor the battery run time.
- Perform commands such as UPS start-up and shut-down and transfer the load between INVERTER and BYPASS.
- Access diagnostic and test facilities (service mode).
- Adjust the UPS configuration and operating parameters (service mode).

### 4.2.2 Mimic LED indicators

The mimic diagram leds indicate the operational status of the UPS power blocks, and change colour between Green and Red (and OFF) to indicate the active power flow through the UPS.

LINE 1 (rectifier) and LINE 2 (bypass) indicate the availability of the UPS input mains (and bypass mains) power supply.

INVERTER and BYPASS, when green, indicates which of the two sources is supplying the critical load power.

The BATTERY LED indicator flashes when the battery is supplying the load – e.g. following a mains failure.

The ALARM LED is a visual indication of an internal or external alarm condition. When activated, it is accompanied by an audible warning.

#### LED Indication summary

Indicator	Status	Interpretation
LINE 1	GREEN RED	Mains available Mains not available
LINE 2	GREEN RED OFF	Mains bypass OK Mains bypass not OK or not present UPS is turned OFF
ALARM	OFF RED	No alarm condition Alarm condition (has been reset)
INVERTER	GREEN RED OFF	Load on inverter Inverter fault Inverter not operating (switched OFF)
BY-PASS	GREEN OFF	Load on bypass Bypass not operating (switched OFF)
BATTERY	GREEN RED Flashing GREEN	Battery OK Battery fault or discharged On Battery

### 4.2.3 Operator keys

The operator keys allow the user to:

- Make settings and adjustments via the menu driven LCD display.
- Start-up and shut-down the UPS and transfer the load between inverter and bypass.
- Monitor and display the UPS operating voltages, currents, frequencies and other values on the LCD display.



**Key function summary**

KEYS	FUNCTION
ON/OFF ON/OFF	Used to switch-on or switch-off the UPS. Both keys must be pressed simultaneously.
UP (▲)	Scroll upwards through a displayed menu.
DOWN (▼)	Scroll downwards through a displayed menu.
RESET	Cancels the audible alarm. If the alarm condition was transient the ALARM LED will also extinguish, otherwise it will remain ON (red).
ENTER	Confirms (selects) a chosen menu item.

**ON/OFF Start-up and shutdown buttons**

The UPS may be switched ON or OFF by simultaneously pressing both ON/OFF buttons on the control panel. The inclusion of two buttons is designed to prevent accidental UPS start-up or shutdown.

During normal operation, pressing the two *ON/OFF* keys will immediately shutdown the UPS module.

- In a single module installation this will disconnect the UPS from the load.
- In a parallel module system the UPS module will shutdown; however, the load may or may-not transfer to the bypass supply in the remaining module(s), depending on the prevailing load and available module redundancy.

**Note:** To shut down all the modules in a parallel system you must press both *ON/OFF* buttons on every module!



**CAUTION:** If the OFF buttons are operated on all the UPS module while the UPS is not on Maintenance Bypass it will interrupt the load power supply.

**4.3 Description of the LCD display**

**4.3.1 Status screens**

DESCRIPTION	LCD-DISPLAY
1. Load is protected by UPS power supplied by the inverter (normal operation). The batteries are connected and OK.	LOAD PROTECTED P05
2. Load is not protected. It is either supplied by mains power (load on bypass) or it is supplied by the inverter (normal operation) and the batteries are not OK.	LOAD NOT PROTECTED P01
3. Load supply interrupted. The UPS has been switched off by the ON/OFF buttons.	LOAD OFF SUPPLY FAILURE P04
4. The UPS module is not supplying load.	LOAD DISCONNECTED P06

**Note:** On the right hand side of the LCD there is a 3 digit indicator defining the module's position in a multi-module system. The maximum number of modules in a parallel system is ten.

### 4.3.2 Main menu screen

DESCRIPTION	LCD-DISPLAY
1. A log of the last 64 events is stored in the Power Management Display (See paragraph 4.3.3).	→ EVENT LOG MEASUREMENTS
2. Allows monitoring of voltages, power, frequencies, currents, autonomy etc (See paragraph 4.3.4)	→ MEASUREMENTS COMMANDS
3. Enables the commands "Load to inverter", "Load to bypass" and battery test to be executed (See paragraph 4.3.5).	→ COMMANDS UPS DATA
4. Allows the UPS personalized information (such as serial number) to be entered (See paragraph 4.3.6).	→ UPS DATA SET-UP USER
5. Allows user to set up Date/Time, automatic battery test, etc. (See paragraph 4.3.8)	→ SET-UP USER SET-UP SERVICE
6. Password-protected area for service engineer use only (See paragraph 4.3.8).	→ SET-UP SERVICE

### 4.3.3 Event log menu screen

DESCRIPTION	LCD-DISPLAY
1. Logging Control; a log of the last 64 events is stored in the Power Management Display.	01 05-10-08 14-38-56 LOAD TO INV.
2. Every stored event is identified with a sequential number and time stamp.	02 05-10-08 14-38-59 LOAD TO BYP.
3. All events and alarms are indicated with their date and time of appearance.	03 05-10-08 14-39-14 LOAD OFF

### 4.3.4 Measurements menu screen

DESCRIPTION	LCD-DISPLAY
1. Battery Runtime	BATT. RUN TIME (MIN) 00h 00mm
2. UPS-Output Frequency	OUTPUT FREQUENCY (HZ) 50.00
3. Bypass Frequency.	BYPASS FREQUENCY (HZ) 50.00
4. Battery Voltage	BATTERY VOLTAGE (V) +0.0 - 0.0
5. Battery Charger Current	BATT. CHARGE CUR. (A) + 0.0 - 0.0
6. Battery Discharge Current.	DISCHARGE CURRENT (A) 00.00
7. Rectifier Input Voltage (all three phases)	RECTIFIER VOLTAGE (V) 000 000 000
8. Bypass Input Voltage (all three phases)	BYPASS VOLTAGE (V) 000 000 000
9. Output Voltage (all three phases)	OUTPUT VOLTAGE (V)0 000 000 000
10. Output Current (all three phases)	OUTPUT CURRENT (A)0 0.00 00.00 00.00

DESCRIPTION	LCD-DISPLAY
11. Active Output Power (all three phases)	ACTIVE POWER (KW) 00.00 00.00 00.00
12. Reactive Output Power (all three phases)	REACTIVE POWER (kVAR) 00.00 00.00 00.00
13. Apparent Output Power (all three phases)	APPARENT POWER (KVA) 00.00 00.00 00.00
14. Output Power (all three phases)	OUTPUT POWER (%) 00.00 00.00 00.00
15. Battery capacity	BATT. CAPACITY (%) 00.00

#### 4.3.5 Commands menu screen

DESCRIPTION	LCD-DISPLAY
1. Transfer Load to inverter	→ LOAD TO INVERTER LOAD TO BYPASS
2. Transfer Load to bypass.	→ LOAD TO BYPASS PERFORM BATT. TEST
3. Battery Test	→ PERFORM BATT. TEST

#### 4.3.6 UPS Data menu screen

DESCRIPTION	LCD-DISPLAY
1. These general UPS Data are installed at the manufacturing plant.	UPS SERIAL NUMBER nn-nnnnnn
2. Manufacturing date	DATE OF MANUFACTURE 15-03-09
3. EPROM Version	EPROM VERSION V-000
4. Actual Date and Time	DATE                      TIME dd-mm-yyyy            hh:mm:ss

#### 4.3.7 Set-Up Service menu screen

DESCRIPTION	LCD-DISPLAY
1. This Menu is reserved for authorized service engineers only.	→ SET-UP SERVICE PASSWORD
2. Type in password	→ PASSWORD*

### 4.3.8 Set-up User menu screen

DESCRIPTION	LCD-DISPLAY
1. Set-up language	<div style="border: 1px solid black; padding: 2px;">           → SET LANGUAGE            SET DATE AND TIME            ENGLISH            FRANCAIS            DEUTCH            DUTCH            SPANISH            POLISH            PORTOGUESE         </div>
2. Set-up Date and Time	<div style="border: 1px solid black; padding: 2px;">           → SET-UP DATE/TIME            SET-UP BATT. TEST            DD-MM-YY HH-MM-SS         </div>
3. Set-up battery test	<div style="border: 1px solid black; padding: 2px;">           → SET-UP BATT. TEST            SET-UP GEN-SET OPER.            DAY OF MONTH            (1-31)            HOUR OF DAY            (0-23)            REPETITIVE (Y/N)            000         </div>
4. Set-up operation with Gen-Set	<div style="border: 1px solid black; padding: 2px;">           → SET-UP GEN-SET OPER.            BATT. CHARGE LOCK            (Y/N)            BYPASS LOCK            (Y/N)         </div>

### 4.3.9 Set-Up Service menu screen

DESCRIPTION	LCD-DISPLAY
1. This Menu is reserved for authorized service engineers only.	<div style="border: 1px solid black; padding: 2px;">           → SET-UP SERVICE            PASSWORD         </div>
2. Type in password	<div style="border: 1px solid black; padding: 2px;">           → PASSWORD*         </div>

## 4.4 Operating modes

### 4.4.1 On-line (inverter) mode

When the UPS is operating in the on-line mode, the load is supplied through the LINE 1 (RECTIFIER) and INVERTER. This provides the highest degree of protection, especially in the event of a mains disturbance or failure, and is always recommended if the critical load (e.g. computer systems) will not tolerate even very brief supply interruption.

In the event of an inverter fault, or overload condition, the UPS transfers the load to the bypass supply automatically and without interruption, (transfer time = 0).

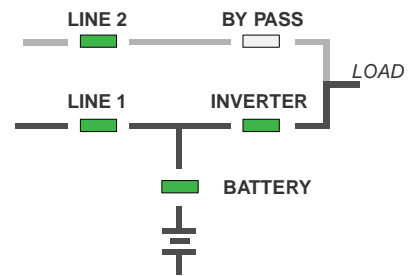

Figure 4.2 On-line mode

### 4.4.2 On-bypass (line-interactive) mode

In the on-bypass (line-interactive) mode the load is normally supplied from the bypass mains (LINE 2) and the static BYPASS. In the event of a bypass supply failure the load is automatically transferred to the inverter within 3 to 5 msec – this is valid for single and parallel module systems. The battery charger remains active in this mode.

Although the on-bypass mode offers greater efficiency than the on-line mode, it is recommended only if the load can tolerate interruptions of up to 3-5 ms, which is the transfer time taken when switching from the on-bypass mode to the on-line mode.

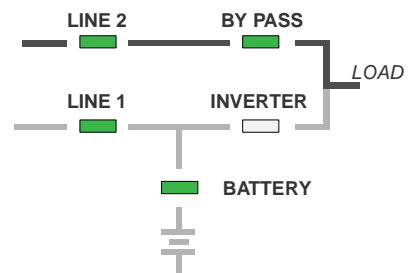

Figure 4.3 On-bypass mode

### 4.4.3 Maintenance bypass mode

Each cabinet is fitted with a maintenance bypass switch (IA1) which, when closed, connects the UPS module(s) output terminals directly to the UPS bypass mains supply. This facility allows the UPS system to be shut down for maintenance or repair whilst maintaining the load on the raw (unprotected) bypass supply.



**WARNING:** ALL the UPS modules in a parallel module system must be selected to on-bypass mode before the maintenance bypass switch is operated closed.

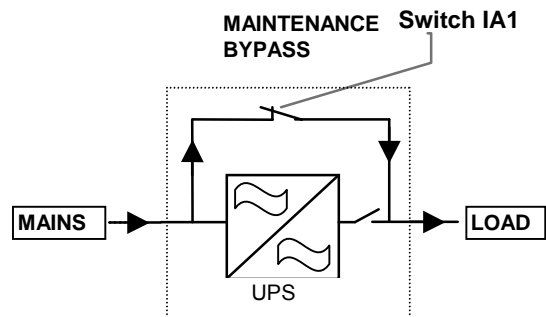

Figure 4.4 Maintenance bypass mode

#### Maintenance bypass switch (IA1)

The maintenance bypass mode is effected by means of the IA1 BYPASS SWITCH on the front of the UPS:

Switch IA1	Effect
ON (CLOSED)	Maintenance Bypass-Switch Closed (Load on bypass mains) LCD-indication: MAINTENANCE BYP CLOSED. LED Indicators will indicate as shown in the table below.
OFF (OPEN)	Bypass-Switch Open – Normal operating condition (Load on inverter) LCD-indication MAINTENANCE BYP OPEN. LED Indicators will indicate as shown in the table below.

LED Indicator	Switch IA1 ON	Switch IA1 OFF
LINE 1	Green	Green
LINE 2	Green	Green
BYPASS	Green	ON
INVERTER	RED	ON
BATTERY	Green	Green



**CAUTION:** When the UPS is operating on maintenance bypass the load is not protected in the event of a mains disturbance or failure, and we therefore strongly recommend that you switch over to the on-line or on-bypass mode as soon as possible.

## 4.5 Operating Instructions

Under normal operating conditions all the modules in a multi-module system are running and operating in the on-line mode (See paragraph 4.4.1).

The following procedures are provided in this section:

- How to start up the UPS system and transfer the load from the maintenance bypass to the on-line mode (See paragraph 4.5.1).
- How to stop/start one UPS module in a redundant multi-module system (See paragraph 4.5.2)
- How to transfer the load to the maintenance bypass – (See paragraph 4.5.3).
- How to shut down the entire UPS system (See paragraph 4.5.4).

### 4.5.1 Starting the UPS system from the maintenance bypass

This procedure describes the sequence of operations necessary to power-up the UPS module(s) whilst the load is connected to the Maintenance Bypass supply, and then transfer the load to the UPS Inverter(s) ('On-Line' mode).



**WARNING:** All the operations in this section must be performed by authorised and trained personnel.

Prior to powering-up the system, check and confirm the UPS system status:

- The load is supplied via the closed maintenance bypass switch (IA1).
- All UPS modules are powered down.

#### Powering up the UPS module(s):

Perform steps 1-3 below on each UPS module.

1. Close the fused battery isolator for the UPS module in the UPS cabinet, or in the external battery cabinet/rack, as applicable.
  - a) The UPS mimic panel LINE 1 LED will be permanent green.
  - b) The BATTERY LED will be flashing green.
  - c) The LCD display will indicate LOAD OFF, SUPPLY FAILURE.
2. On the UPS control panel press and release both ON/OFF buttons simultaneously then wait 60 seconds.
  - a) The UPS module will begin to power up.
  - b) Initially LINE 2 LED will be red, then change to green.
  - c) At this stage the LCD display will indicate LOAD NOT PROTECTED and the module mimic LED indications should be as illustrated here.
3. Ensure that ALL the UPS modules are in the state shown before continuing with this procedure.

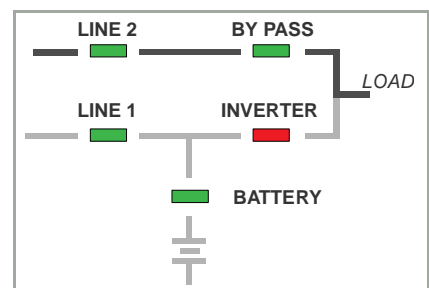
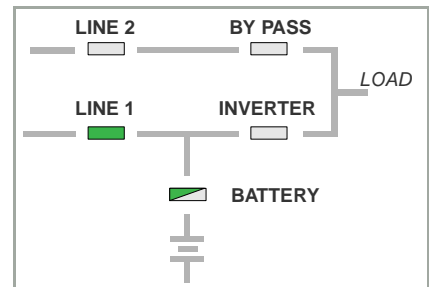

**Transferring the load to the UPS from the Maintenance Bypass:**

4. Ensure that the BYPASS LED is green (*on all UPS modules*).
5. Open the maintenance bypass switch (IA1).
  - a) The LCD panels will display MANUAL BYPASS OPEN.
  - b) The INVERTER LED will be extinguished.
  - c) An audible alarm will sound.
6. Press the RESET button to cancel the audible alarm (*on all UPS modules*).
  - a) The LCD display will now indicate LOAD NOT PROTECTED.
7. On the control panel (*of any one module* in a multi-module system):
  - a) Press the UP key once to access the menu system.
  - b) Use the UP/DOWN keys to move the cursor so that it is adjacent to COMMANDS and then press the ENTER key.
  - c) Use the UP/DOWN keys to move the cursor so that it is adjacent to LOAD TO INVERTER and then press the ENTER key.
8. The UPS system will transfer the load to the inverter (*on all UPS modules* in a multi-module system).
  - a) The LCD display(s) will now indicate LOAD PROTECTED.
  - b) Check and confirm that the LED displays are as illustrated here.
9. The UPS is now operating in its on-line mode. The load is protected and supplied by inverter power.

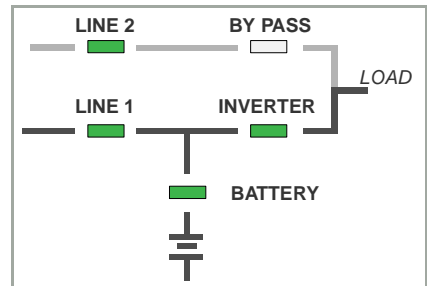
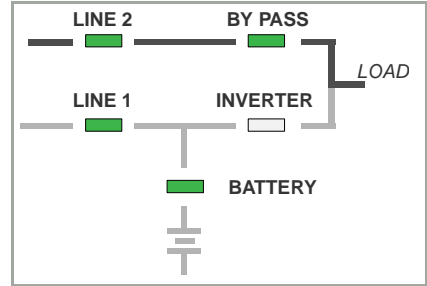

**4.5.2 Individual UPS module start/stop procedure**

If a multi-module system is designed with built-in redundancy, it is possible to stop and start one UPS module without affecting the operational status of the overall system – i.e. one UPS module can be taken off-line whilst the remaining modules remain operating in their on-line mode and maintain a protected load supply.



**WARNING:** All the operations in this section must be performed by authorised and trained personnel.

**UPS module shut-down:**

Use this procedure to power-down one module in a redundant module system.

1. Simultaneously press the two ON/OFF buttons on the UPS control panel.
  - a) The LED display will give the indications shown.
2. Open the fused battery isolator for the UPS module in the UPS cabinet or in the external battery cabinet/rack, as applicable.
3. The UPS module is now totally shut-down.



**WARNING:** Although the UPS module is shut-down it is still connected to the input/bypass mains.

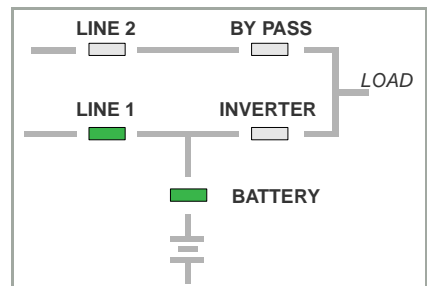

**UPS module start-up:**

Use this procedure to start a UPS module and connect it to a multi-module system that is already running.

1. Close the fused battery isolator for the UPS module in the UPS cabinet or in the external battery cabinet/rack, as applicable.

## 4: Operation

2. Simultaneously press the two ON/OFF push buttons on the UPS control panel.
  - a) The UPS will run through an automated start-up sequence accompanied by the following indications:  
 LINE 2 LED lights red then changes to green.  
 INVERTER LED lights green.  
 BATTERY LED lights green (constant).
  - b) LCD displays the LOAD PROTECTED message.
3. The UPS module is now on-line and connected to the parallel system.

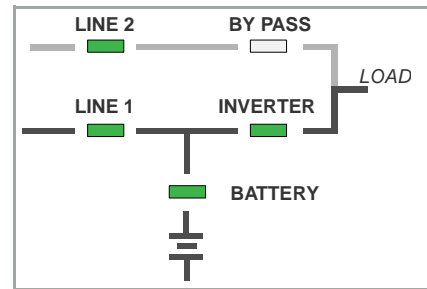

### 4.5.3 Transfer to maintenance bypass mode

If required, the load can be transferred to the maintenance bypass supply to enable the UPS module to be powered down for maintenance or servicing. This will connect the load to the unprotected bypass mains supply.



**WARNING:** Before you close the maintenance bypass switch (IA1) ensure that the UPS is operating in its on-bypass mode. All the operations in this section must be performed by authorised and trained personnel.

This procedure describes the sequence of operations to transfer the load to the maintenance bypass supply and then shut down the UPS module(s).

Prior to commencing this procedure, check and confirm the following UPS system status (*on all working UPS modules in a multi-module system*):

- The mimic panel LED indications should be as shown below (*on all working UPS modules*):

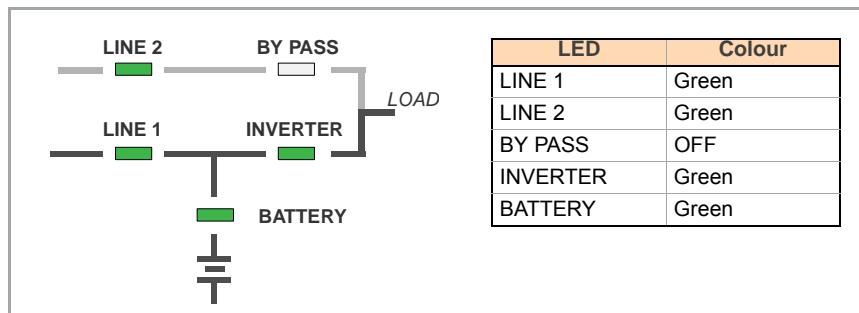

- The LCD panel should display LOAD PROTECTED. If anything other than LOAD PROTECTED is displayed then press the RESET button, and if LOAD PROTECTED is still not displayed there is a problem with the UPS system and you should seek assistance!

#### Transferring the UPS to the on-bypass mode:

1. On the control panel (*of any one module in a multi-module system*):
  - a) Press the UP key once to access the menu system.
  - b) Use the UP/DOWN keys to move the cursor so that it is adjacent to COMMANDS and then press the ENTER key.
  - c) Use the UP/DOWN keys to move the cursor so that it is adjacent to LOAD TO BYPASS then press the ENTER key.
2. The UPS system will transfer the load to static bypass – on all UPS modules in a parallel system.
3. *On all UPS module* check and confirm that:
  - a) The INVERTER LED has extinguished.
  - b) The BYPASS LED is green.
  - c) The LCD displays LOAD NOT PROTECTED.

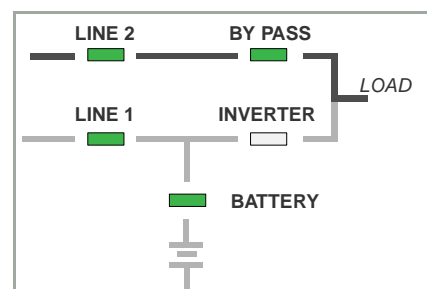



**Closing the maintenance bypass switch:**

4. Close the maintenance bypass switch (IA1).
5. On **all** UPS module check and confirm that:
  - a) The INVERTER LED has changed to red.
  - b) The BYPASS LED is green.
  - c) The LCD displays MANUAL BYP IS CLOSED.

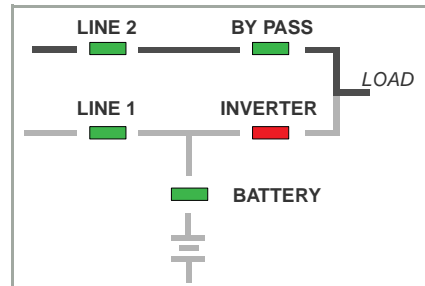

**Powering down a UPS module:**

When the load is connected to the maintenance bypass supply, as described above, the UPS module(s) can be totally powered down (for example, if required for maintenance/testing) using the following procedure:

*Note: Carry out the following procedure on each UPS module in a parallel system.*

6. On the UPS control panel simultaneously press both ON/OFF buttons.
  - a) The LCD panel will indicate: LOAD OFF , SUPPLY FAILURE.
7. Open the fused battery isolator for the UPS module in the UPS cabinet or in the external battery cabinet/rack, as applicable.



**WARNING:** The UPS module/cabinets are still live at the input and output power terminals due to the closure of maintenance bypass switch.

**WARNING:** The load is now supplied from the bypass mains and is not protected against power failure.

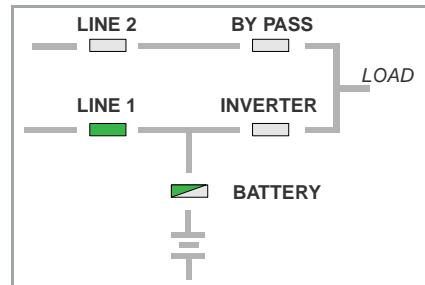

**4.5.4 Complete system shutdown**

If the load does not need power for an extended period of time the UPS system can be shutdown completely using the following procedure.



**WARNING:** All the operations in this section must be performed by authorised and trained personnel.



**CAUTION:** This procedure will totally disconnect load power. Ensure that it is safe to lose power to all the loads connected to the UPS system before you begin this process.

1. Isolate all load equipment connected to the UPS system by opening the fused isolators or circuit breakers in the UPS output load distribution board.



**WARNING:** Perform the following steps only after the load has been fully isolated.

2. On the UPS control panel simultaneously press both ON/OFF buttons.
  - a) The LCD panel will indicate: LOAD OFF , SUPPLY FAILURE.
3. Open the fused battery isolator for the UPS module(s) in the UPS cabinet or in the external battery cabinet/rack, as applicable.
  - a) The mimic indications should be as illustrated here.
4. Open the UPS Input isolators (and Bypass supply isolators in a dual feed system) at the building power distribution panel.
5. The UPS is now voltage free.

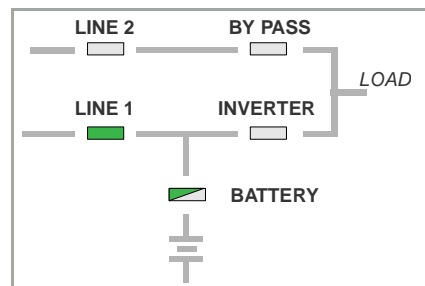

## 4.6 Replacing a UPS module in a single module system



**WARNING:** All the operations in this section must be performed by authorised and trained personnel.



**WARNING:**

A UPS module weighs up to 22kg. If the UPS module is handled inappropriately it might cause serious injury or damage. We recommend that the modules are handled by two persons at all times. Always employ suitable lifting aids and safety platforms where possible.

### 4.6.1 Extracting the UPS module

1. Transfer the load to the maintenance bypass supply (See paragraph 4.5.3).
2. Simultaneously press the two ON/OFF buttons on the UPS control panel.
  - a) The mimic indications should be as illustrated here.
3. Open the fused battery isolator for the UPS module in the UPS cabinet or in the external battery cabinet/rack, as applicable.
4. The UPS module is now totally shut-down.
5. Remove the two screws on the front of the UPS module that are securing it to the cabinet.
6. Using the two black handles, pull the UPS module forwards until the rear connectors are disconnected. DO NOT FULLY EXTRACT THE UNIT.

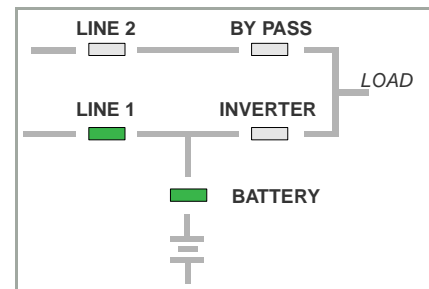

**WARNING:** Wait at least 2 minutes to allow the module's electrolytic capacitors time to discharge.

7. After two minutes, fully withdraw the UPS module from the cabinet by pulling it horizontally.
8. If you are not intending to replace the UPS module immediately, fit a blanking cover over the UPS compartment opening and secure it in place using the screws removed earlier.

### 4.6.2 Refitting the UPS module

1. Remove the blanking cover (if fitted).
2. Using two people, lift the UPS module and slide it two thirds of the way into the UPS compartment (make sure not to plug the UPS module into the rear connector).
3. Push UPS module firmly into its final position, to assure good contact on the rear plugs.
4. Secure the module in place using the screws removed earlier.
5. Start the UPS module and bring it on line (See paragraph 4.5.2).

## 4.7 Replacing a UPS module in a REDUNDANT multi-module system



**WARNING:** All the operations in this section must be performed by authorised and trained personnel.



**WARNING:** A UPS module weighs up to 22kg. If the UPS module is handled inappropriately it might cause serious injury or damage. We recommend that the modules are handled by two persons at all times. Always employ suitable lifting aids and safety platforms where possible.

If a UPS module is faulty in a redundant multi-module system, the load will continue to be protected by the remaining modules which will continue to operate in the on-line mode. Under these circumstances the faulty module may be replaced without having to transfer the load to bypass.

### 4.7.1 Extracting the UPS module

1. Identify the faulty UPS module with the alarm condition and RESET the alarm. The audible noise will stop. If the red ALARM LED remains on, there is a fault in the module.
2. Verify that load is being supplied by the other module(s) by checking that their LCD panels show LOAD PROTECTED.
3. On the UPS module to be replaced, simultaneously press the two ON/OFF buttons on the UPS control panel.

a) The mimic indications should be as illustrated here.

4. Open the fused battery isolator for the UPS module in the UPS cabinet or in the external battery cabinet/rack, as applicable.
5. The UPS module is now totally shut-down.
6. Remove the two screws on the front of the UPS module that are fixing it to the cabinet.
7. Using the two black handles, pull the UPS module forwards until the rear connectors are disconnected. DO NOT FULLY EXTRACT THE UNIT.

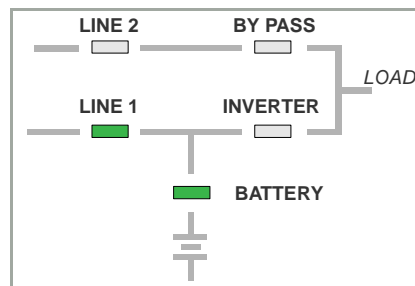

**WARNING:** Wait at least 2 minutes to allow the module's electrolytic capacitors time to discharge.

8. After two minutes, fully withdraw the UPS module from the cabinet by pulling it horizontally.
9. If you are not intending to replace the UPS module immediately, fit a blanking cover over the UPS compartment opening and secure it in place using the screws removed earlier.

### 4.7.2 Refitting the UPS module

1. Remove the blanking cover (if fitted).
2. Using two people, lift the UPS module and slide it two thirds of the way into the UPS compartment (make sure not to plug the UPS module into the rear connector).
3. Push UPS module firmly into its final position, to assure good contact on the rear plugs.
4. Secure the module in place using the screws removed earlier.
5. Start the UPS module and bring it on line (See paragraph 4.5.2).

## 4.8 Replacing a UPS module in a CAPACITY multi-module system



**WARNING:** All the operations in this section must be performed by authorised and trained personnel.



**WARNING:** A UPS module weighs up to 22kg. If the UPS module is handled inappropriately it might cause serious injury or damage. We recommend that the modules are handled by two persons at all times. Always employ suitable lifting aids and safety platforms where possible.

If a UPS module is faulty in a capacity parallel system, the load will automatically transfer to the modules' static bypass which will then operate in the on-bypass mode.

### 4.8.1 Extracting the UPS module

1. Identify the faulty UPS module with the alarm condition and RESET the alarm. The audible noise will stop. If the red ALARM LED remains on, there is a fault in the module.
2. Verify that load is supplied from the bypass supply.
3. Close the maintenance bypass switch (IA1).

## 4: Operation

4. On **all** UPS module check and confirm that:
  - a) The INVERTER LED has turned to red.
  - b) The BYPASS LED is green.
  - c) The LCD panel displays MANUAL BYP IS CLOSED.
5. Open the fused battery isolator for the UPS module in the UPS cabinet or in the external battery cabinet/rack, as applicable.
6. The UPS module is now totally shut-down.
7. Remove the two screws on the front of the UPS module that are fixing it to the cabinet.
8. Using the two black handles, pull the UPS module forwards until the rear connectors are disconnected. **DO NOT FULLY EXTRACT THE UNIT.**

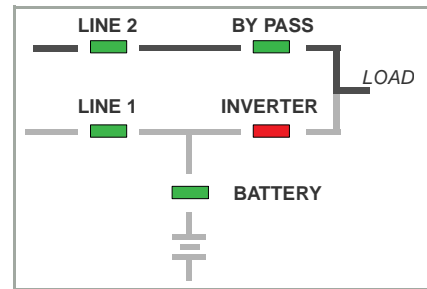

**WARNING:** Wait at least 2 minutes to allow the module's electrolytic capacitors time to discharge.

9. After two minutes, fully withdraw the UPS module from the cabinet by pulling it horizontally.
10. If you are not intending to replace the UPS module immediately, fit a blanking cover over the UPS compartment opening and secure it in place using the screws removed earlier.

### 4.8.2 Refitting the UPS module

1. Remove the blanking cover (if fitted).
2. Using two people, lift the UPS module and slide it two thirds of the way into the UPS compartment (make sure not to plug the UPS module into the rear connector).
3. Push UPS module firmly into its final position, to assure good contact on the rear plugs.
4. Secure the module in place using the screws removed earlier.
5. Start the UPS module and transfer the system from the maintenance bypass back to inverter (*See paragraph 4.5.1*).

# 5 Maintenance

## 5.1 Introduction



**WARNING:** All the operations described in this chapter must be performed by suitably qualified personnel.

## 5.2 System calibration

To ensure optimum UPS operation and efficient load protection we recommended that the system's operating parameters are checked every six months and recalibrated where necessary. The batteries should also be checked every six months, depending on the ambient temperature.

## 5.3 User responsibilities

There are no user-serviceable parts contained within the UPS so the maintenance requirements to be carried out by the user are minimal beyond ensuring that the local environment in which the UPS operates is kept cool, clean and dust free.

## 5.4 Routine maintenance

It is essential that the UPS system and batteries receive regular preventative maintenance inspection to maximise both the useful working life and system reliability. When the UPS is commissioned, the commissioning engineer will attach a service record book to the front of the UPS which will be used to log the full service history of the UPS.



**WARNING:** Preventative maintenance inspections involve working inside the UPS which contains hazardous AC and DC voltages, and should be performed only by an authorised engineer who has been trained by Uninterruptible Power Supplies Ltd.

During a preventative maintenance inspection the maintenance engineer will check:

- Site/environment conditions.
- Integrity of electrical installation.
- Cooling airflow.
- Rectifier operation and calibration.
- Inverter operation and calibration.
- Static switch operation.
- Battery status.
- Load characteristics.
- Integrity of alarm and monitoring systems.
- Operation of all installed options.

Preventative maintenance inspections form an integral part of all Extended Warranty Agreements (maintenance contracts) offered by Uninterruptible Power Supplies Ltd. For further details see Paragraph 2.6.

### 5.5 Battery testing

The battery test takes approximately 3 minutes to complete and should be performed only if:

- There are no alarm conditions.
- The battery is fully charged.
- The input mains supply is present.

The battery test procedure can be performed from the UPS front panel and can be carried out irrespective of the operating mode (off-line or on-line) and whether or not the load is connected.

### 5.6 Battery maintenance

The battery maintenance shall be done by an authorized Uninterruptible Power Supplies Ltd Service Partner.

### 5.7 Battery disposal and recycling

Batteries contain dangerous substances that can harm the environment if disposed of carelessly. If you have reason to change the batteries, always consult with your local environmental waste disposal organisations to obtain the recommended disposal and recycling information.

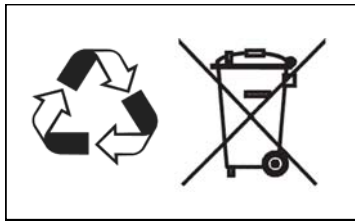

# 6 Troubleshooting

## 6.1 Alarms

If an alarm condition occurs, the red ALARM LED will illuminate on the UPS control panel and the audible alarm will sound. In this case proceed as follows:

1. Silence the audible alarm by pressing the RESET button.
2. Identify the cause of the alarm by viewing the events register in the main menu (*See paragraph 4.3.3*).
3. In case of doubt contact your nearest service agent or call Uninterruptible Power Supplies Ltd. on 0800 731 3269.

## 6.2 Menu, Commands, Event Log, Measurements,

A detailed description of the Menu, Commands, Event Log and Measurements that can be operated and displayed on the LCD panel can be found in paragraph 4.3.

## 6.3 Fault Identification and Rectification Messages and Alarms

Alarm Condition	Meaning	Suggested Solution
UPS FAULT	There is a fault in the UPS and therefore normal operation cannot be guaranteed.	Call the authorised service centre for assistance.
MAINS BYP/RECT FAULT	Mains power supply is outside prescribed tolerance.	The input power to UPS is high/low or missing. If site power appears to be OK, check the input circuit breakers etc. supplying the UPS.
OUTPUT SHORT	There is a short circuit at the UPS output.	Check all output connections and repair as required.
OVERLOAD	Load exceeds the UPS rated power.	Identify which piece of equipment is causing the overload and remove it from the UPS. Do not connect laser printers, photocopiers, electric heaters, kettles etc. to the UPS.
OVERTEMPERATURE	UPS temperature has exceeded the allowed value.	Check the ambient temperature of the UPS is less than 30° C. If the ambient temperature is normal call the authorised service centre for assistance.
BATTERY CHARGER OFF	The attached battery and the battery charger set-up do not correspond or battery charger fault.	Call the authorised service centre for assistance.
INVERTER FAULT	Inverter is faulty.	Call the authorised service centre for assistance.
SYNCHRON FAULT	The inverter and mains are not synchronised.	The frequency of the input voltage to the UPS is outside operational limits and the UPS static bypass has been temporarily disabled.
BATTERY IN DISCHARGE	Battery is near end of autonomy.	Shutdown load connected to UPS before the UPS switches itself off to protect its batteries.
MANUAL BYP IS CLOSED	Maintenance Bypass closed. Load supplied by raw bypass mains.	This alarm is only displayed if the UPS is on Maintenance Bypass.

## 6.4 Contacting Service

Uninterruptible Power Supplies Limited has a service department dedicated to providing routine maintenance and emergency service cover for your UPS.

If you have any queries regarding your UPS please contact us.

Uninterruptible Power Supplies Ltd.  
Woodgate  
Bartley Wood Business Park  
Hook  
Hampshire  
RG27 9XA

Tel: 01256 386700  
0800 731 3269 (24 Hr.)

Fax: 01256 386701

Email: [service@upspower.co.uk](mailto:service@upspower.co.uk)

We recommend that your UPS is protected by an Extended Warranty Agreement – see Section 2 for details. These agreements assist us in caring for your UPS correctly, ensuring that it is well maintained and attended to promptly should any problems occur.



# 7 Options

## 7.1 Introduction

The PW8000DPA ST UPS has the following available options:

- Remote emergency stop facilities
- Generator ON facilities
- 1 x Customer-input function (customer defined)
- WaveMON shutdown and management software
- SNMP Card for network management and remote monitoring
- Modem/Ethernet interface for PowerReporter™ management software

## 7.2 Remote emergency stop

The remote emergency stop facility takes the form of a normally-closed contact which opens to operate the emergency stop sequence.

On leaving the factory the remote emergency stop function is disabled and it must be activated by a hardware code on the SETUP SERVICE menu. Please contact your distributor to enable this operation if required.

The remote shutdown facility is connected to terminal port X1/7 – X1/8 on the communication card located on the PW8000DPA ST front frame.

In order to allow the safe removal, maintenance or testing of the remote emergency stop device, without affecting the UPS operation, it is recommended that a terminal block with linking facilities is installed between the UPS and the remote emergency stop mechanism.

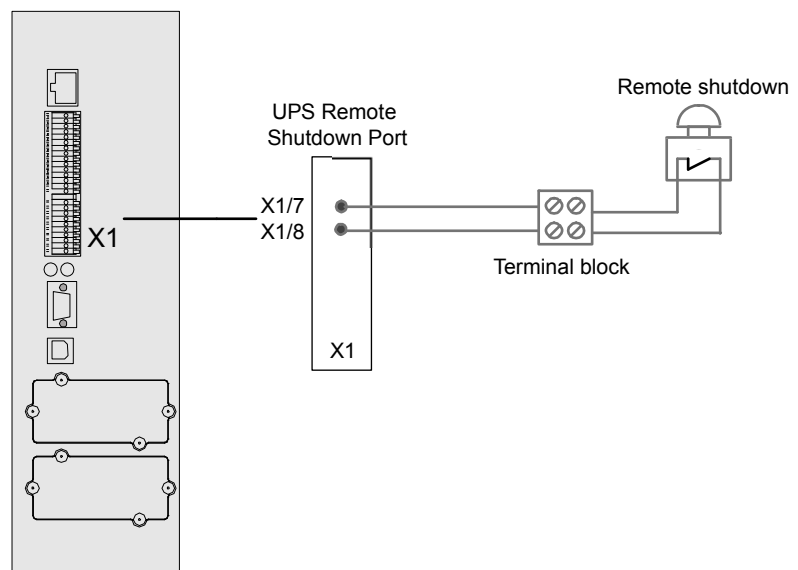

Figure 7.1 Remote emergency stop cabling

1. Use a screened cable with a single pair (0.6 mm<sup>2</sup>) and maximum length of 100 m.
2. Connect the cable as shown in Figure 7.1.

### 7.3 Generator ON facilities

The Generator ON facility must use a normally-open contact which closes to signal that a generator is running and supplying the UPS input power.

When used, this facility enables the option to inhibit the operation of the battery charger and/or static bypass. See “Set-up User menu screen” in section 4.3.8.

1. Use a screened cable with a single pair (0.6 mm<sup>2</sup>) and maximum length of 100 m.
2. Connect the cable as shown in Figure 7.2.

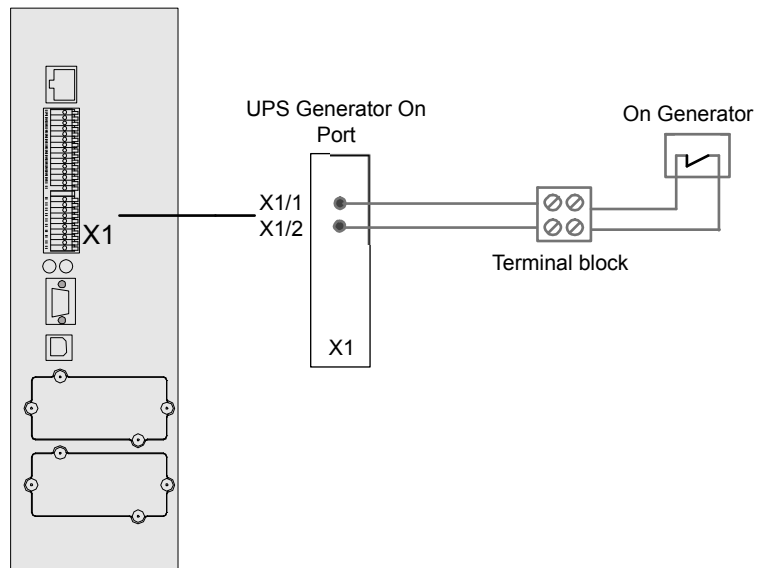

Figure 7.2 Generator ON Connection

### 7.4 UPS Monitoring and automated control software

#### 7.4.1 SNMP Card slots

Simple Network Management Protocol (SNMP) is a world-wide, standardised communication protocol that can be used to monitor any network-connected device via a simple control language and display the results in an application running within a standard web browser.

The PW8000DPA ST contains two SNMP slots; one is designed to house a Modem/Ethernet SNMP adapter card and the other a Modem/GSM adapter. Alternatively, SNMP connectivity can also be implemented using an external SNMP adapter connected to the UPS RS232 output (JD1).

An SNMP/Ethernet adapter contains an RJ-45 connector which allows it to be connected to the network using a standard network cable. Once connected, the UPS-Management software agent, which is already installed in the SNMP adapter, then monitors the UPS operating parameters and outputs its data in SNMP format to the connected network. In a multi-module UPS system the SNMP interface can communicate ‘system-wide’ data or data for an individual UPS module.

The SNMP adaptor requires a PC with terminal connections, and for normal operation at least one network connection (Ethernet) is also required.

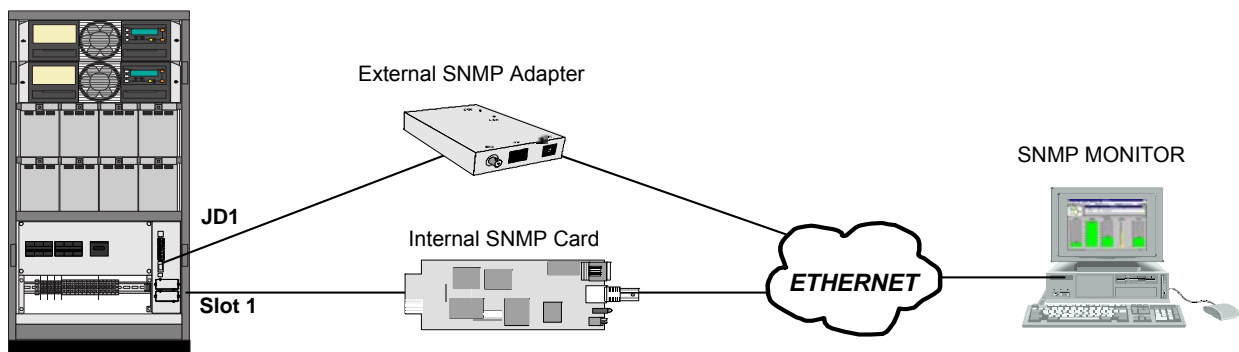

Figure 7.3 SNMP Internal and external adapters

### 7.4.2 The importance of UPS management

The utility supply is inevitably unreliable every now and then; and assuring continuous power to all the facilities connected to it can be a difficult task. The situation is further complicated if worldwide systems are managed via a Local Area Network (LAN) or Wide Area Network (WAN).

However, by using the PW8000DPA ST UPS system in conjunction with purpose-designed network management tools, a systems administrator can take measures to back-up data and prevent system errors or data loss even in the event of a relatively long utility supply outage. In the case of an abnormal utility supply, suitable UPS management software will also enable a system administrator to monitor all concerned networks from a central point and identify bottlenecks at an early stage.

In spite of extensive system monitoring, if an administrator fails to intervene in a timely manner serious damage can still occur. It is important therefore that the installed UPS software will react automatically in such a case and shut down the supplied system in a safe and controlled manner. Uninterruptible Power Supplies Ltd considers it important to have a complete solution for its UPS systems, and offers its customers a number of remote control and monitoring tools to provide optimum protection.

Two monitoring system options are available for use with the PW8000DPA ST UPS system:

#### SNMP monitoring software

The SNMP adapter described above requires a PC with terminal connections and, for normal operation, at least one Ethernet network connection. It also requires that the network operating system in use is SNMP-compatible. Uninterruptible Power Supplies Ltd offer suitable monitoring software with SNMP functionality for NetWare, OS/2, all Windows NT systems on INTEL and ALPHA network platforms.

#### WAVEMON UPS monitoring and control software

WAVEMON is designed to operate in conjunction with many of the systems supplied by Uninterruptible Power Supplies Ltd and features both UPS monitoring and automatic UPS/server shutdown facilities.

### 7.4.3 WAVEMON Shutdown and Monitoring Software

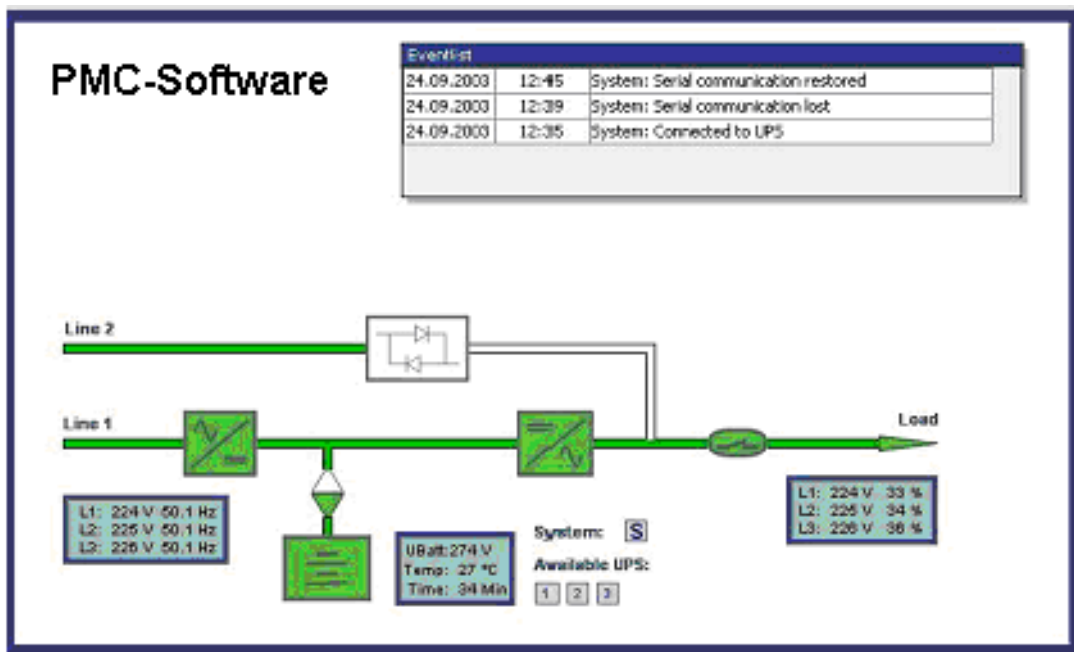

Figure 7.4 Monitoring screen image

WAVEMON comprises a bespoke software package which is installed on a local PC and communicates with the UPS via USB or a standard RS232 serial cable of up to 15m in length. It is only required when an SNMP card or adapter box is not purchased.

The main features of WAVEMON are:

- On-screen autonomy time/battery time countdown.
- On-screen server log-off and shutdown procedure.
- Time and date stamp event log.
- Extensive logging of all UPS activity and power quality data.
- Permits alarm warnings to be monitored remotely via email.
- Scheduled UPS service mode and other systems status.
- Graphical user interface for Windows-compatible platforms.
- Automatic unattended local shutdown.
- Special modules for MS-Office software to close and save open documents.
- Compatible with all optional modules like UPSDIALER, SNMP adaptors, temperature sensors, etc.

#### 7.4.4 Functional description

WAVEMON is a client/server software application for networks and local workstations. In general, it consists of two parts: the server module of the UPS management software is *UPSMAN*, which communicates with the UPS via an RS232/USB interface. Running as a background application, *UPSMAN* collects and interprets the messages received from the UPS and places them at the disposal of the client module *UPSMON*, as well as any connected SNMP-based instrumentation and control system.

If *UPSMAN* detects voltage variations or a power failure, it can execute various 'system event' routines, by means of which, for example, the server is switched off or a warning/alarm is sent to the connected users. These 'system event' routines are a part of the management software and can be configured in to suit local application requirements.

The software of your PW8000DPA ST UPS unit can be integrated into a network in two ways:

1. By the server which is supplied by the UPS itself and has been integrated into the network. In most cases this server is used as a sub-agent and you only need the WAVEMON software (without an SNMP adapter). You will also need to establish an RS232/USB connection between the UPS and computer/server.
2. In many cases the use of what is referred to as an 'SNMP adapter' is to be preferred in order to integrate the UPS into the network. In this case up to 50 computers can be shut down in one RCCMD environment. RCCMD (remote console command) is an additional software module that is used in order to execute a command (typically a shutdown command) in a remote system.

#### 7.4.5 Licensing

A licence is issued with every software serial number for use of what is known as the 'UPS service' on a single server in connection with one UPS and an unlimited number of connected WINDOWS workstations. For operation with two or more servers, a further licence is required for each additional server. In this case it is of no importance whether the UPS service on these servers is active or whether the server was stopped by a remote UPS service. The same applies to the use of RCCMD with the 'remote send/receive' modules for 'multi-server shutdown' under NT, UNIX and other operating systems.

The service programs are generally supplied as single licences. In order to use a single CD-ROM for several 'multi-server shut-down' units you must acquire additional licence codes.

#### 7.4.6 RCCMD Server shutdown

In order that remote shutdown of servers can take place, initiated by the SNMP card or WAVEMON software, further licenses must be purchased. The license s for the RCCMD client (or listening) software that resides in each target server.

## 7.5 PowerREPORTER™ management software

PowerREPORTER is a remote monitoring and management service which provides peace-of-mind protection by offering a continuous (24/7/365) watch over mission-critical facilities. Continuous monitoring is an affordable insurance policy to detect issues and provide an early warning before they develop into a crisis.

The main features and benefits offered by PowerREPORTER are:

- Real time email notification sent directly to UPSL Service Centre in response to alarm/critical events.
- Acquisition of key performance data and productivity information. Empowers you with the details needed to better understand machine performance and quickly troubleshoot downtime events.
- Combined with a service contract, PowerREPORTER improves service levels. The engineer can determine if site attendance is necessary and bring relevant spare parts.
- Monthly Status Report detailing trends and alarms.
- Optional battery analysis and care service; PowerNSURE - measures battery voltage, temperature, impedance and prolongs battery service life through the application of battery charge equalization.

### 7.5.1 Functional description

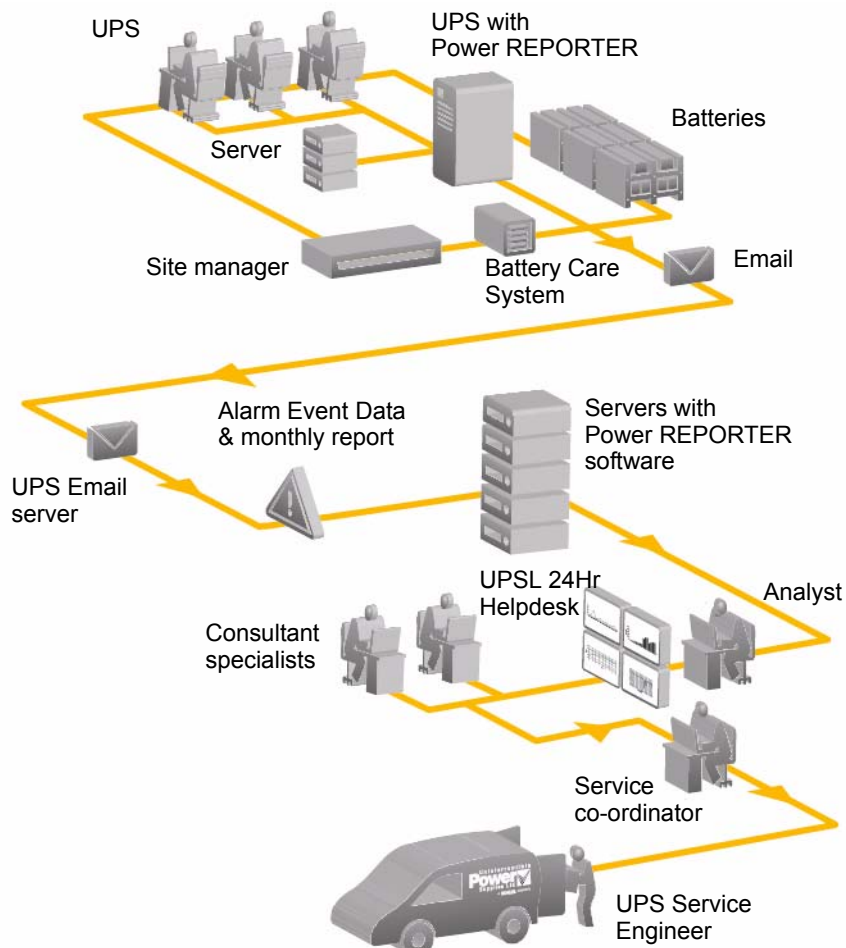

Figure 7.5 PowerREPORTER operation

PowerREPORTER communicates constantly with your UPS system in order to automatically detect any error or alarm messages. In the event of an incident being detected, PowerREPORTER automatically connects with UPSL's Service Centre via an email, transmitting a status message.

The email, which provides details relating to the fault, a snapshot of the UPS performance parameters and a device identification string, is automatically processed and UPSL's Service Centre personnel are alerted.

UPSL's Service Centre personnel are then able to liaise with the company's field service team and will remotely diagnose the UPS incident before reaching the facility with appropriate spare parts within the contracted service agreement timeframe.

# 8 Specification

## 8.1 Mechanical Characteristics – UPS Cabinet

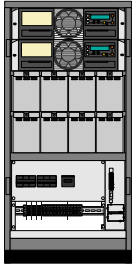
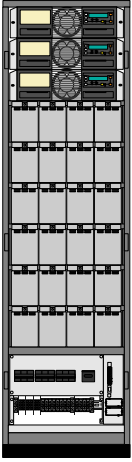
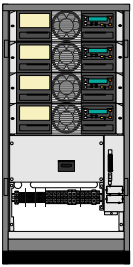
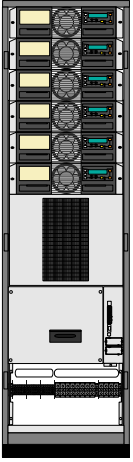
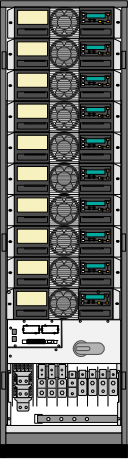
		ST-40	ST-60	ST-80	ST-120	ST-200
						
Maximum Configuration		2 module (10 or 20kVA) and 80 x 7/9Ah batteries	3 modules (10 or 20kVA) and 240 x 7/9Ah batteries	4 modules (10 or 20kVA) and NO batteries	6 modules (10 or 20kVA) and NO batteries	10 modules (10 or 20kVA) and NO batteries
Max. Power	kW	40	60	80	120	200
Dimensions (WxHxD)	mm	550x1135x770	550x1975x770	550x1135x770	550x1975x770	
Weight of Empty Cabinet	kg	92	173	82	133	174
Weight with modules and no batteries	kg	130 up to 136 (with 2 Modules)	229 up to 238 (with 3 Modules)	157 up to 169 (with 4 Modules)	245 up to 263 (with 6 Modules)	360 up to 389 (with 10 Modules)
Colours	Front: Graphite grey (Pulverlacke No. 4222903402 serie 09RCCAT1) Side walls: Graphite grey (Pulverlacke No. 4222903402 serie 09RCCAT1)					

## 8.2 Mechanical Characteristics – UPS Module

		10kVA UPS Module	20kVA UPS Module
Output Active Rated Power	kW	10	20
Number of 12V Battery Blocks	No.	24-50 *	36-50 *
Dimensions (WxHxD)	mm	488 x 132 x 540 (3 HU)	
Weight UPS Module	kg	18.6	21.5
Colours		Front: RAL 7016	
*Depending of the effective load in kW used by the module			

## 8.3 Input Characteristics

		10kVA UPS Module	20kVA UPS Module
Output Rated Power per Module $\cos\phi$ 0.8	kVA	10	20
Output Rated Power per Module $\cos\phi$ 1.0	KW	10	20
Nominal Input Voltage	V	3x380/220V+N, 3x400V/230V+N, 3x415/240V+N	
Input Voltage Tolerance (ref to 3x400/230V) for Loads in %:	V	(-23%/+15%) 3x308/177 V to 3x460/264 V for <100% load (-30%/+15%) 3x280/161 V to 3x460/264 V for < 80% load (-40%/+15%) 3x240/138 V to 3x460/264 V for < 60% load	
Input Frequency	Hz	35 – 70	
Input Power Factor		PF=0.99 @ 100% load	
Inrush Current	A	max. In	
Input Distortion THDI		Sine-wave THDi = 3% @ 100% load	
Max. Input Power with rated output power and charged battery per Module (output $\cos\phi$ = 1.0)	kW	10.5	21
Max. Input Current with rated output power and charged battery per Module (output $\cos\phi$ = 1.0)	A	15.2	30.4
Max. Input Power with rated output power and discharged battery per Module (output $\cos\phi$ = 1.0)	kW	11.5	23
Max. Input Current with rated output power and discharged battery per Module (output $\cos\phi$ = 1.0)	A	16.6	33.3

## 8.4 Battery Characteristics

		10kVA UPS Module	20kVA UPS Module
Variable Number of 12V Battery Blocks	No.	24-50 *	36-50 *
Maximum Battery Charger Current	A	4 A	4 A
Battery Charging Curve		Ripple free: IU (DIN 41773)	
Temperature compensation		Standard (temp. sensor optional)	
Battery Test		Automatic and periodically (adjustable)	
Battery Type		Maintenance free VRLA or NiCd	
* Depending of the effective load in kW used by the module			

## 8.5 Battery Capacity Usage

	10kVA UPS Module				20kVA UPS Module			
	24	28	30	34-50	36	40	40	48-50
Number of battery blocks	24	28	30	34-50	36	40	40	48-50
Max. Power in KW	8	8	10	10	16	20	16	20
Max. autonomy (min.)	5	999	5	999	5	5	999	999



## 8.6 Heat Dissipation Per Module With Non-Linear Load

		10kVA UPS Module	20kVA UPS Module
Heat dissipation with 100% non-linear load per module (EN 62040-1-1:2003)	W	550	1100
	BTU/h	1887	3745
Airflow (25° - 30°C) with non-linear load per module (EN 62040-1-1:2003)	m <sup>3</sup> /h	150	150
Dissipation at no load	W	130	170

## 8.7 Output Characteristics

		10kVA UPS Module	20kVA UPS Module
Output Rated Power per Module Cosφ 0.8	kVA	10	20
Output Rated Power per Module Cosφ 1.0	KW	10	20
Output Current In @ Cosφ 1.0 (400 V)	A	14.5	29
Output Rated Voltage	V	3x380/220V or 3x400/230V or 3x415/240V	
Output Voltage Stability	%	Static: < +/- 1% Dynamic (Step load 0%-100% or 100%-0%)< +/- 4%	
Output Voltage Distortion	%	With Linear Load< 1.5% With Non-linear Load (EN62040-3:2001)< 3%	
Output Frequency	Hz	50 Hz or 60 Hz	
Output Frequency Tolerance	%	Synchronized with mains < +/- 2% (selectable for bypass operation) or < +/- 4% Free running +/- 0.1%	
Bypass operation		At Nominal Input voltage of 3x400 V +/- 15% or 199 V to 264 V ph-N	
Permissible Unbalanced Load (All 3 phases regulated independently)	%	100%	
Phase Angle Tolerance (With 100% Unbalanced load)	Deg.	+/- 0 deg.	
Overload Capability on Inverter	%	125% load 10 min. 150% load 60 sec.	
Output short capability (RMS)	A	Inverter: 3 x In during 40 ms Bypass: 10 x In during 20 ms	
Crest - Factor		3: 1	

## 8.8 Standards

	10kVA UPS Module	20kVA UPS Module
Safety	EN 62040-1-1:2003, EN 60950-1:2001/A11:2004	
Electromagnetic Compatibility	EN 62040-2:2005, EN61000-3-2:2000, EN61000-3-3:1995/A1:2001, EN61000-6-2:2001	
Emission Class	C2	
Immunity Class	C3	
Performance	EN62040-3:2001	
Product certification	CE	
Degree of protection	IP 20	

## 8.9 Environmental Characteristics

		10kVA UPS Module	20kVA UPS Module
Audible Noise with 100% / 50% Load	dBA	55 / 49	57 / 49
Operation temperature	°C	0 – 40	
Ambient Temperature for Batteries (recommended)	°C	20	
Storage Temperature	°C	-25 - +70	
Battery Storage Time at Ambient Temperature		Max. 6 months	
Max. altitude (above sea level)	m	1000m (3300ft) without de-rating	
De-rating factor for use at altitudes above 1000m sea level according (IEC 62040-3)		Height above sea level (m / ft)	De-Rating Factor for Power
		1500 / 4850	0.95
		2000 / 6600	0.91
		2500 / 8250	0.86
		3000 / 9900	0.82
Relative Air-humidity		Max. 95% (non-condensing)	
Accessibility		Totally front accessibility for service and maintenance (no need for side, top or rear access)	
Positioning		Min. 20 cm rear space (required for fan)	
Input and Output Power Cabling		From the bottom on the front	
Efficiency AC-AC up to (at $\cos\phi$ 1.0) (depending on Module power)	%	Load: 100%75%50%25% 20kVA: 95.5% 95.5%95%94.5% 10kVA: 95.5% 95.5%95%94.5%	
Efficiency with Linear Load at $\cos\phi$ =0.8 lagging Efficiency Non-linear Load (EN 62040-1-1:2003)		Typically up to 1% higher of above values Typically up to 1% lower of above values	
Eco-Mode efficiency at 100% load	%	98%	

## 8.10 Communication Options

Power Management Display (PMD)	1 x LCD display for each module
RJ45 Plug (Not used)	RJ45 Plug (for future options)
Customer Interfaces: Outputs DRY PORT X2	5 Voltage free contacts For remote signalling and automatic computer shutdown
Customer Interfaces: Inputs DRY PORT X1	1 x Remote Shut-down [EMERGENCY OFF (normally closed)] 2 x Programmable Customer Inputs 1st. default as GEN-ON (normally open) 2nd. free (normally open) 1 x Temperature sensor for battery control 1 x 12Vdc output (max 200mA)
1 x Remote Shut down [EMERGENCY OFF (Normally closed)]	2 x Programmable Customer's Inputs (1 <sup>st</sup> default as GEN-ON (Normally open) (2 <sup>nd</sup> free Programmable Customer's Inputs (Normally open)
Serial ports RS232 on Sub-D9	1 x system frame For monitoring integration in network management and service
USB	1x For monitoring and software management
Slot for SNMP	SNMP card (optional) For monitoring and integration in network management
	For monitoring and integration in network management
Slot for PowerREPORTER	PowerREPORTER card (optional) for Premium Power Protection

## 8.11 Fuses & Cables Quick Reference

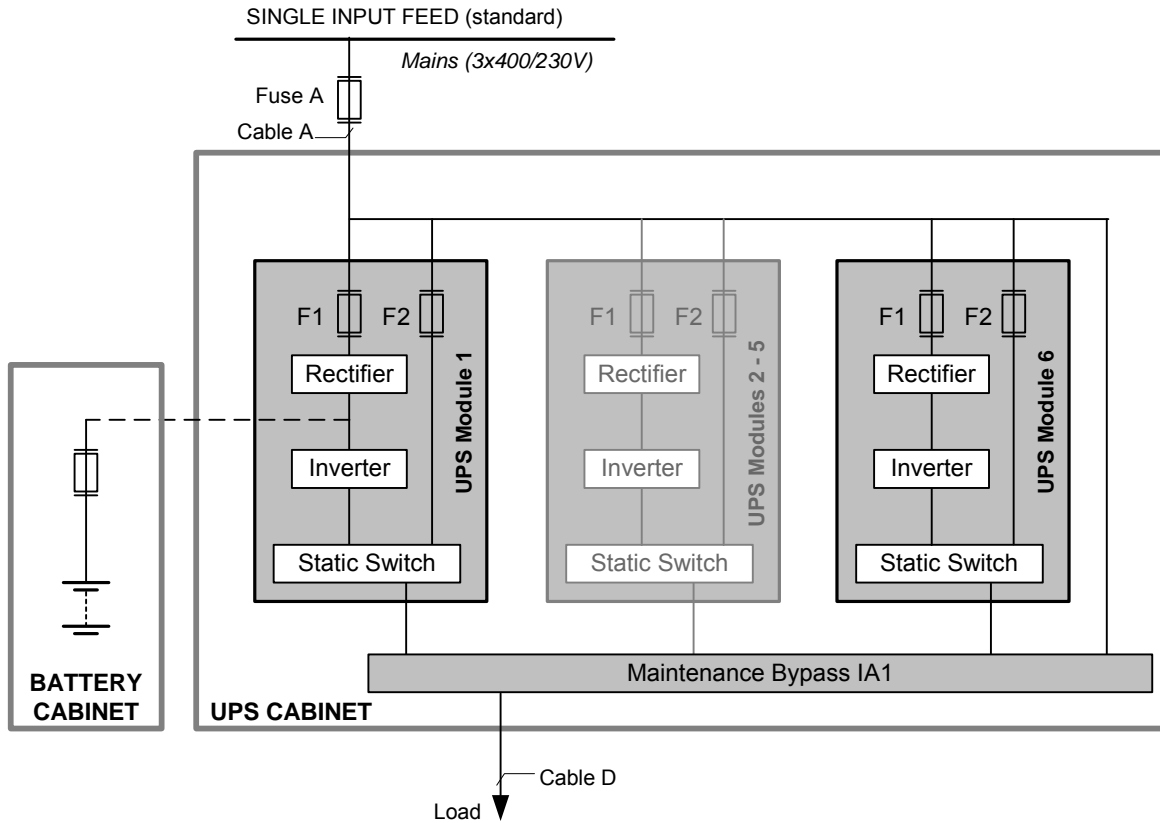

### Cabinet Mounted – Single Input Feed

	Input 3x400V/230V			Output 3x400V/230V	
	Fuse A (Agl/CB)	Cable A (mm <sup>2</sup> )	Max I/P Current	Cable D (mm <sup>2</sup> )	I(nom)
ST-40	3x80A	5x16	68A	5x16	58A
ST-60	3x125A	5x35	102A	5x35	87A
ST-80	3x160A	5x50	136A	5x50	116A
ST-120	3x224A	4x95 + 1x50(PE)	208A	5x70	174A
ST-200	3x350A	5x185	333A	5x185	200A

#### Notes:

1. Fuse and Cable recommendations to IEC 60950-1:2001
2. The fuse and cable rating details in the above tables are a recommendation only.
3. The UPS must be installed to prescribed IEC or local regulations (e.g. BS7671:2008).
4. DC Cables and Battery fuses are bespoke to the installation.

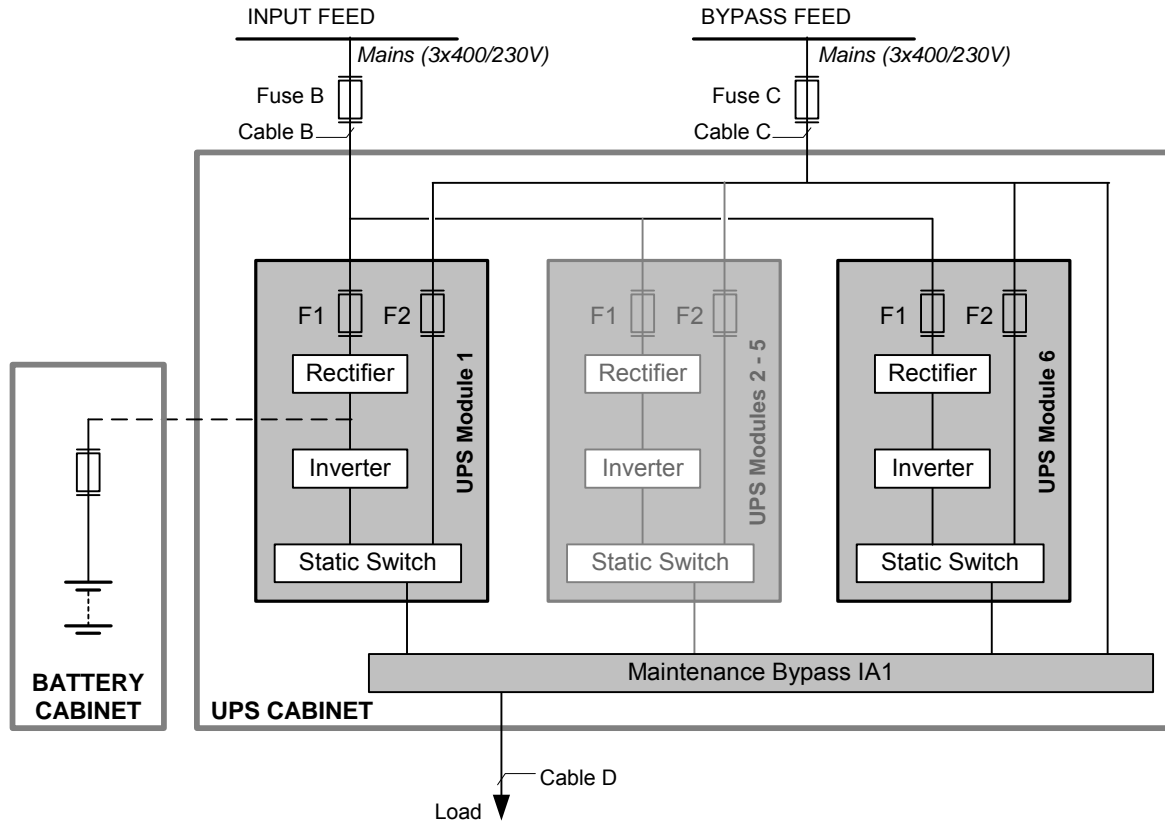

**Cabinet Mounted – Dual Input Feed**

	Input 3x400V/230V			Input 3x400V/230V		Output 3x400V/230V	
	Fuse B (Agl/CB)	Cable B (mm <sup>2</sup> )	Max I/P Current	Fuse C (Agl/CB)	Cable C (mm <sup>2</sup> )	Cable D (mm <sup>2</sup> )	I(nom)
ST-40	3x80A	5x16	68A	3x80A	4x16	5x16	58A
ST-60	3x125A	5x35	102A	3x125A	4x35	5x35	87A
ST-80	3x160A	5x50	136A	3x160A	4x50	5x50	116A
ST-120	3x224A	4x95 + 1x50(PE)	208A	3x224A	4x95	5x70	174A
ST-200	3x350A	5x185	333A	3x350A	4x185	5x185	290A

**Notes:**

1. Fuse and Cable recommendations to IEC 60950-1:2001
2. The fuse and cable rating details in the above tables are a recommendation only.
3. The UPS must be installed to prescribed IEC or local regulations (e.g. BS7671:2008).
4. DC Cables and Battery fuses are bespoke to the installation.