

# JVC

## SERVICE MANUAL

### MICRO COMPONENT SYSTEM

# UX-G38B, UX-G38E, UX-G38EN, UX-G38EV, UX-G39E, UX-G39EN, UX-G39EV, UX-G37B, UX-G37E, UX-G37EN, UX-G37EV

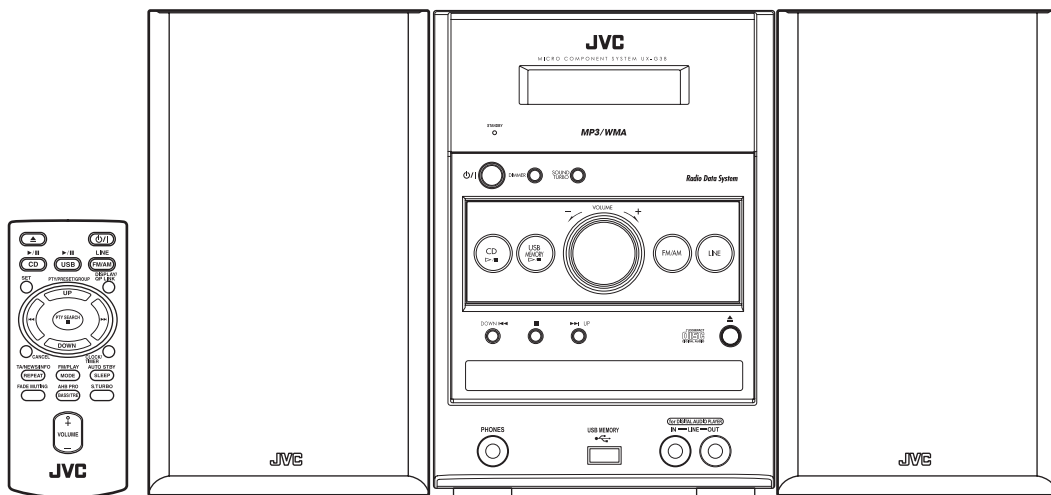

SP-UXG38  
SP-UXG38  
SP-UXG39

CA-UXG37  
CA-UXG38  
CA-UXG39

SP-UXG38  
SP-UXG38  
SP-UXG39



### MP3/WMA Radio Data System

UX-G39 is derivative model and different color model of UX-G38.  
UX-G37 is different color model of UX-G38.

Lead free solder used in the board (material : Sn-Ag-Cu, melting point : 219 Centigrade)  
Lead free solder used in the board (material : Sn-Cu, melting point : 230 Centigrade)

### TABLE OF CONTENTS

1	PRECAUTION	1-3
2	SPECIFIC SERVICE INSTRUCTIONS	1-7
3	DISASSEMBLY	1-8
4	ADJUSTMENT	1-19
5	TROUBLESHOOTING	1-19

## SPECIFICATION

Amplifier section	OUTPUT POWER	40 W (20 W + 20 W) at 6 $\Omega$ (10% THD)
	Speakers/Impedance	500 mV/47 k $\Omega$ (at "LINE IN LVL1")
	Audio input LINE IN	250 mV/47 k $\Omega$ (at "LINE IN LVL2") 125 mV/47 k $\Omega$ (at "LINE IN LVL3")
	Audio output LINE OUT	1.0 Vrms (47 k $\Omega$ ) (at "LINE OUT LVL1") 2.0 Vrms (47 k $\Omega$ ) (at "LINE OUT LVL2")
	Digital input	USB MEMORY
Tuner section	FM tuning range	87.50 MHz - 108.00 MHz
	AM (MW) tuning range	522 kHz - 1 629 kHz
CD player section	Dynamic range	88 dB
	Signal-to-noise ratio	85 dB
	Wow and flutter	Immeasurable
USB storage	USB specification	Compatible with USB 2.0 Full Speed
	Compatible device	Mass storage class
	Compatible file system	FAT16, FAT32
	Bus power supply	Max. 500 mA
Speakers	Speaker units	10 cm cone $\times$ 1
	Impedance	6 $\Omega$
	Dimensions (approx.)	145 mm $\times$ 251 mm $\times$ 162 mm (W/H/D)
	Mass (approx.)	1.6 kg each
General	Power requirements	AC 230 V , 50 Hz
	Power supply to USB mass storage class device	5 V/500 mA
	Power consumption	22 W (power on) 3.0 W (standby mode) 1.5 W or less (Save Mode)
	Dimensions (W $\times$ H $\times$ D)	175 mm $\times$ 251 mm $\times$ 247 mm
	Mass	2.6 kg

Specifications and appearance are subject to change without prior notice.

# SECTION 1 PRECAUTION

## 1.1 Safety Precautions

- (1) This design of this product contains special hardware and many circuits and components specially for safety purposes. For continued protection, no changes should be made to the original design unless authorized in writing by the manufacturer. Replacement parts must be identical to those used in the original circuits. Services should be performed by qualified personnel only.
- (2) Alterations of the design or circuitry of the product should not be made. Any design alterations of the product should not be made. Any design alterations or additions will void the manufacturer's warranty and will further relieve the manufacturer of responsibility for personal injury or property damage resulting therefrom.
- (3) Many electrical and mechanical parts in the products have special safety-related characteristics. These characteristics are often not evident from visual inspection nor can the protection afforded by them necessarily be obtained by using replacement components rated for higher voltage, wattage, etc. Replacement parts which have these special safety characteristics are identified in the Parts List of Service Manual. Electrical components having such features are identified by shading on the schematics and by ( $\Delta$ ) on the Parts List in the Service Manual. The use of a substitute replacement which does not have the same safety characteristics as the recommended replacement parts shown in the Parts List of Service Manual may create shock, fire, or other hazards.
- (4) The leads in the products are routed and dressed with ties, clamps, tubings, barriers and the like to be separated from live parts, high temperature parts, moving parts and/or sharp edges for the prevention of electric shock and fire hazard. When service is required, the original lead routing and dress should be observed, and it should be confirmed that they have been returned to normal, after reassembling.

### (5) Leakage shock hazard testing

After reassembling the product, always perform an isolation check on the exposed metal parts of the product (antenna terminals, knobs, metal cabinet, screw heads, headphone jack, control shafts, etc.) to be sure the product is safe to operate without danger of electrical shock. Do not use a line isolation transformer during this check.

- Plug the AC line cord directly into the AC outlet. Using a "Leakage Current Tester", measure the leakage current from each exposed metal part of the cabinet, particularly any exposed metal part having a return path to the chassis, to a known good earth ground. Any leakage current must not exceed 0.5mA AC (r.m.s.).
- Alternate check method  
Plug the AC line cord directly into the AC outlet. Use an AC voltmeter having, 1,000 $\Omega$  per volt or more sensitivity in the following manner. Connect a 1,500 $\Omega$  10W resistor paralleled by a 0.15 $\mu$ F AC-type capacitor between an exposed metal part and a known good earth ground. Measure the AC voltage across the resistor with the AC

voltmeter.

Move the resistor connection to each exposed metal part, particularly any exposed metal part having a return path to the chassis, and measure the AC voltage across the resistor. Now, reverse the plug in the AC outlet and repeat each measurement. Voltage measured any must not exceed 0.75 V AC (r.m.s.). This corresponds to 0.5 mA AC (r.m.s.).

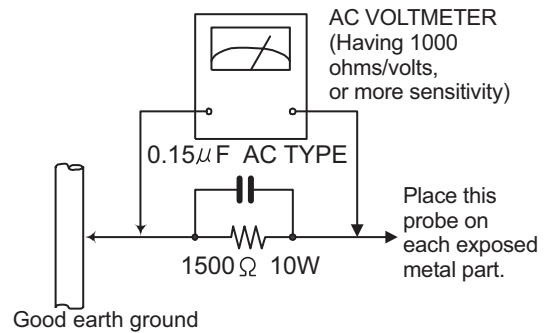

## 1.2 Warning

- (1) This equipment has been designed and manufactured to meet international safety standards.
- (2) It is the legal responsibility of the repairer to ensure that these safety standards are maintained.
- (3) Repairs must be made in accordance with the relevant safety standards.
- (4) It is essential that safety critical components are replaced by approved parts.
- (5) If mains voltage selector is provided, check setting for local voltage.

## 1.3 Caution

**Burrs formed during molding may be left over on some parts of the chassis.**

**Therefore, pay attention to such burrs in the case of pre-forming repair of this system.**

## 1.4 Critical parts for safety

In regard with component parts appearing on the silk-screen printed side (parts side) of the PWB diagrams, the parts that are printed over with black such as the resistor (■), diode (■) and ICP (●) or identified by the " $\Delta$ " mark nearby are critical for safety. When replacing them, be sure to use the parts of the same type and rating as specified by the manufacturer. (This regulation does not Except the J and C version)

## 1.5 Safety Precautions (U.K only)

- (1) This design of this product contains special hardware and many circuits and components specially for safety purposes. For continued protection, no changes should be made to the original design unless authorized in writing by the manufacturer. Replacement parts must be identical to those used in the original circuits.
- (2) Any unauthorised design alterations or additions will void the manufacturer's guarantee; furthermore the manufacturer cannot accept responsibility for personal injury or property damage resulting therefrom.
- (3) Essential safety critical components are identified by (  ) on the Parts List and by shading on the schematics, and must never be replaced by parts other than those listed in the manual. Please note however that many electrical and mechanical parts in the product have special safety related characteristics. These characteristics are often not evident from visual inspection. Parts other than specified by the manufacturer may not have the same safety characteristics as the recommended replacement parts shown in the Parts List of the Service Manual and may create shock, fire, or other hazards.
- (4) The leads in the products are routed and dressed with ties, clamps, tubings, barriers and the like to be separated from live parts, high temperature parts, moving parts and/or sharp edges for the prevention of electric shock and fire hazard. When service is required, the original lead routing and dress should be observed, and it should be confirmed that they have been returned to normal, after re-assembling.

### 1.5.1 Warning

- (1) Service should be performed by qualified personnel only.
- (2) This equipment has been designed and manufactured to meet international safety standards.
- (3) It is the legal responsibility of the repairer to ensure that these safety standards are maintained.
- (4) Repairs must be made in accordance with the relevant safety standards.
- (5) It is essential that safety critical components are replaced by approved parts.
- (6) If mains voltage selector is provided, check setting for local voltage.



**CAUTION** Burrs formed during molding may be left over on some parts of the chassis. Therefore, pay attention to such burrs in the case of preforming repair of this system.

## 1.6 Preventing static electricity

Electrostatic discharge (ESD), which occurs when static electricity stored in the body, fabric, etc. is discharged, can destroy the laser diode in the traverse unit (optical pickup). Take care to prevent this when performing repairs.

### 1.6.1 Grounding to prevent damage by static electricity

Static electricity in the work area can destroy the optical pickup (laser diode) in devices such as laser products.

Be careful to use proper grounding in the area where repairs are being performed.

(1) Ground the workbench

Ground the workbench by laying conductive material (such as a conductive sheet) or an iron plate over it before placing the traverse unit (optical pickup) on it.

(2) Ground yourself

Use an anti-static wrist strap to release any static electricity built up in your body.

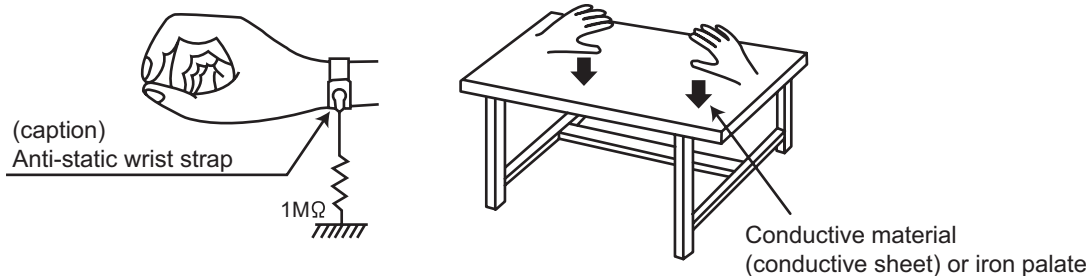

(3) Handling the optical pickup

- In order to maintain quality during transport and before installation, both sides of the laser diode on the replacement optical pickup are shorted. After replacement, return the shorted parts to their original condition. (Refer to the text.)
- Do not use a tester to check the condition of the laser diode in the optical pickup. The tester's internal power source can easily destroy the laser diode.

## 1.7 Handling the traverse unit (optical pickup)

- (1) Do not subject the traverse unit (optical pickup) to strong shocks, as it is a sensitive, complex unit.
- (2) Cut off the shorted part of the flexible cable using nippers, etc. after replacing the optical pickup. For specific details, refer to the replacement procedure in the text. Remove the anti-static pin when replacing the traverse unit. Be careful not to take too long a time when attaching it to the connector.
- (3) Handle the flexible cable carefully as it may break when subjected to strong force.
- (4) It is not possible to adjust the semi-fixed resistor that adjusts the laser power. Do not turn it.

## 1.8 Attention when traverse unit is decomposed

**\*Please refer to "Disassembly method" in the text for the pickup unit.**

- Apply solder to the short land sections before the card wire is disconnected from the connector on the servo board. (If the card wire is disconnected without applying solder, the pickup may be destroyed by static electricity.)
- In the assembly, be sure to remove solder from the short land sections after connecting the card wire.

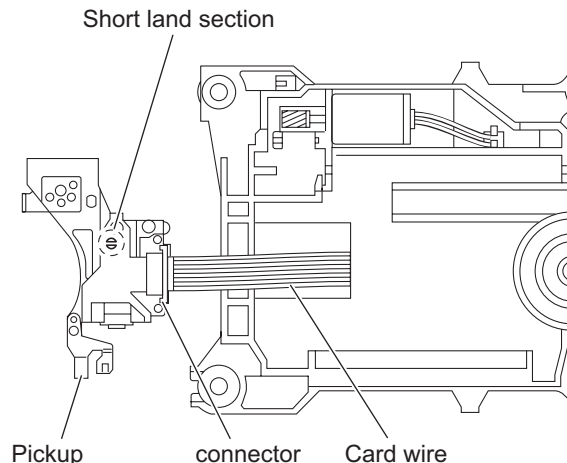

## 1.9 Important for laser products

### 1.CLASS 1 LASER PRODUCT

#### 2.CAUTION :

(For U.S.A.) Visible and/or invisible class II laser radiation when open. Do not stare into beam.

(Others) Visible and/or invisible class 1M laser radiation when open. Do not view directly with optical instruments.

**3.CAUTION :** Visible and/or invisible laser radiation when open and inter lock failed or defeated. Avoid direct exposure to beam.

**4.CAUTION :** This laser product uses visible and/or invisible laser radiation and is equipped with safety switches which prevent emission of radiation when the drawer is open and the safety interlocks have failed or are defeated. It is dangerous to defeat the safety switches.

(For U.S.A.)

**CAUTION :** Visible and/or invisible class II laser radiation when open. Do not stare into beam.

(Others)

**CAUTION :** Visible and/or invisible class 1M laser radiation when open. Do not view directly with optical instruments

**ACHTUNG:** Sichtbare und/oder unsichtbare Laserstrahlung der Klasse 1M bei offenen Abdeckungen. Nicht direkt mit optischen Instrumenten betrachten.

**ATTENTION:** Rayonnement laser visible et/ou invisible de classe 1M une fois ouvert. Ne pas regarder directement avec des instruments optiques.

**VOORZICHTIG:** Zichtbare en/of onzichtbare klasse 1M laserstralen indien geopend. Bekijk niet direct met optische instrumenten.

**ATTENZIONE:** Radiazione laser in classe 1M visibile e/o invisibile quando aperto. Non osservare direttamente con strumenti ottici.

**WARNING:** Synlig och/eller osynlig laserstrålning, klass 1M, när denna del är öppnad. Betrakta ej strålen med optiska instrument.

**VARO!** Avattaessa olet alttiina nakyyvalle ja/tai näkymättömälle luokan 1M lasersateilylle. Älä tarkastele sitä optisen laitteen läpi.

**ADVASEL:** Synlig og/eller usynlig klasse 1M-laserstrålning ved åbning. Se ikke direkte med optiske instrumenter.

**AVISO:** Radiación láser de clase 1M visible y/o invisible cuando está abierto. No mirar directamente con instrumental óptico.

**PRECAUÇÃO:** Radiação laser de classe 1M visível e/ou invisível quando aberto. Não olhe diretamente com instrumentos ópticos.

**5.CAUTION :** If safety switches malfunction, the laser is able to function.

**6.CAUTION :** Use of controls, adjustments or performance of procedures other than those specified here in may result in hazardous radiation exposure.



**CAUTION Please use enough caution not to see the beam directly or touch it in case of an adjustment or operation check.**

**PRECAUÇÃO:** Radiação laser de classe 1M visível e/ou invisível quando aberto. Não olhe diretamente com instrumentos ópticos.

**ПРЕДУПРЕЖДЕНИЕ:** В открытом состоянии происходит видимое и/или невидимое излучение лазера класса 1M. Не смотрите непосредственно в оптические инструменты.

**UWAGA:** Otwarcie spowoduje narażenie na widzialne i/lub niewidzialne promieniowanie lasera klasy 1M. Nie patrzeć bezpośrednio w przyrządy optyczne.

**UPOZORNĚNÍ:** Při otevření vydává viditelné popř. neviditelné laserové ozáření třídy 1M. Nedívejte se do otvoru přímo s optickými nástroji.

**FIGYELMEZTETÉS:** Látható és/vagy láthatatlan 1M osztályú sugárzás nyitott állapotban. Ne nézze közvetlenül optikai műszerekkel.

**注意:** 打開蓋板可能會產生可見或不可見的 1M 級鐳射。不要使用光學儀器直接進行窺視。

**注意:** 打开蓋板可能会产生可见或不可见的 1M 级辐射。不要使用光学仪器直接进行窥视。

**تنبيه:** يوجد إشعاع ليزري مرئي و/أو غير مرئي من الفئة 1M عندما يكون الجهاز مفتوحاً. تجنب النظر مباشرة داخل الجهاز باستخدام أدوات بصرية.

**احتياطات:** هنگامی که باز گردد، تشعشع مرئی و یا نامرئی کلاس 1M لیزر وجود دارد. با لوازم چشمی مستقیماً به آن نگاه نکنید.

**주의:** 개방하면 가시 및/또는 비가시 클래스 1M 레이저 방사선이 나옵니다. 광학 기구로 직접 들여다보지 마십시오.

## REPRODUCTION AND POSITION OF LABELS and PRINT WARNING LABEL and PRINT

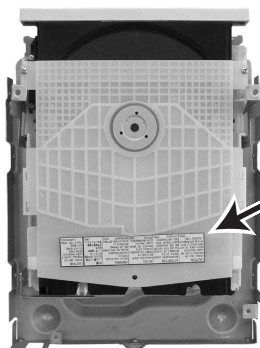

<b>CAUTION</b> VISIBLE AND/OR INVISIBLE CLASS 1M LASER RADIATION WHEN OPEN. DO NOT VIEW DIRECTLY WITH OPTICAL INSTRUMENTS. IEC60825-1:2001	<b>ATTENTION</b> RAYONNEMENT LASER VISIBLE ET/OU INVISIBLE DE CLASSE 1M UNE FOIS OUVERT. NE PAS REGARDER DIRECTEMENT AVEC DES INSTRUMENTS OPTIQUES.	<b>AVISO</b> RADIACIÓN LASER DE CLASE 1M VISIBLE Y/O INVISIBLE CUANDO ESTA ABIERTO. NO MIRAR DIRECTAMENTE CON INSTRUMENTAL OPTICO.	<b>WARNING</b> SYNLIG OCH/ELLER OSYNLIG LASERSTRÅLNING, KLASS 1M, NÄR DENNA DEL ÄR ÖPPNAD. BETRAKTA EJ STRÅLEN MED OPTISKA INSTRUMENT.	<b>注意</b> ニニを照くとき可視 及び/または不可視 のクラス1M レーザー放射が 出ます。 光学装置で直接 見ないでください。	<b>CAUTION</b> VISIBLE AND/OR INVISIBLE CLASS II LASER RADIATION WHEN OPEN. DO NOT STARE INTO BEAM. FDA 21 CFR (ENG) LV44603-003A
---	---	--	--	--	---

**SECTION 2**  
**SPECIFIC SERVICE INSTRUCTIONS**

This service manual does not describe SPECIFIC SERVICE INSTRUCTIONS.

## SECTION 3 DISASSEMBLY

### 3.1 Main body

#### 3.1.1 Removing the Metal cover (See Fig.1, 2)

- (1) Remove the six screws **A** attaching the metal cover. (See Fig.1)
- (2) Remove the two screws **B** attaching the both side of metal cover. (See Fig.2)

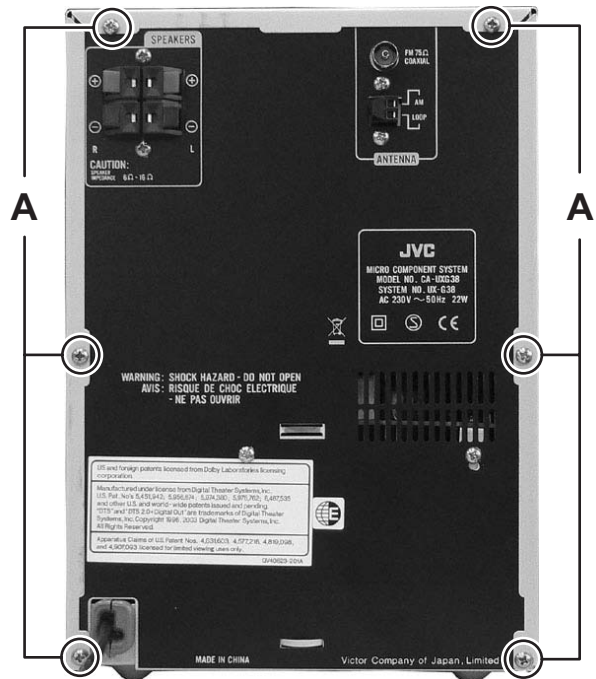

Fig.1

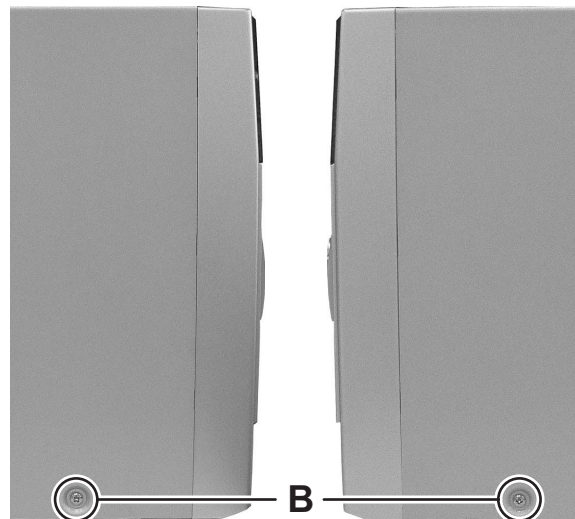

Fig.2

### 3.1.2 Removing the Front panel assembly (See Fig.3 to 5)

- (1) Disconnect the card wire from front panel assembly connected to connector [CN432](#) of the Main board assembly. (See Fig.3)
- (2) Remove the two screws **C** attaching the Front panel assembly. (See Fig.4)
- (3) Disengage the hook **a** engaged Front panel assembly. (See Fig.4)
- (4) Disengage the hook **b** engaged both side of Front panel assembly. (See Fig.5)

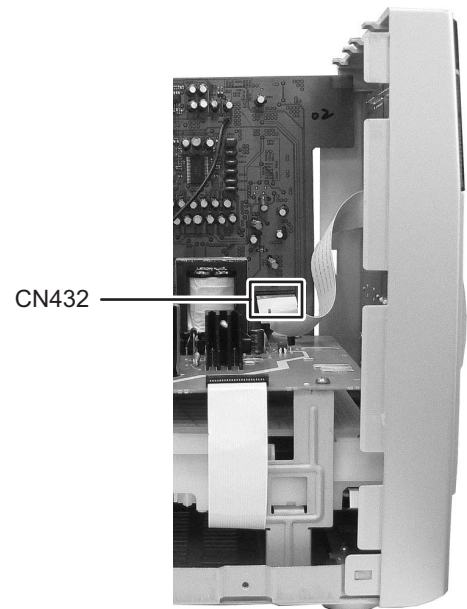

Fig.3

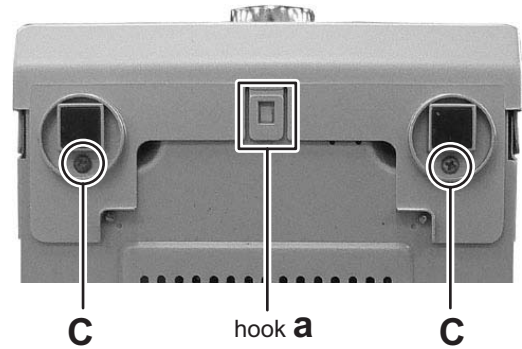

Fig.4

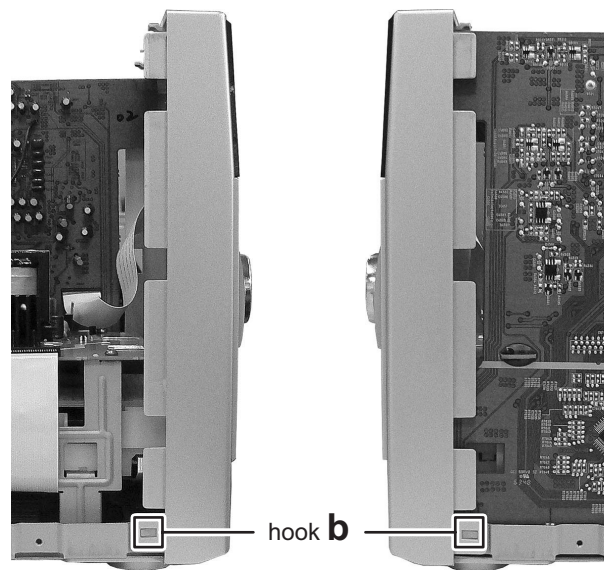

Fig.5

### 3.1.3 Removing the Tuner pack (See Fig.6, 7)

- (1) Disconnect the card wire from Tuner pack connected to connector **CN911** of the Main board assembly. (See Fig.6)
- (2) Remove the two screws **D** attaching the Tuner pack. (See Fig.7)

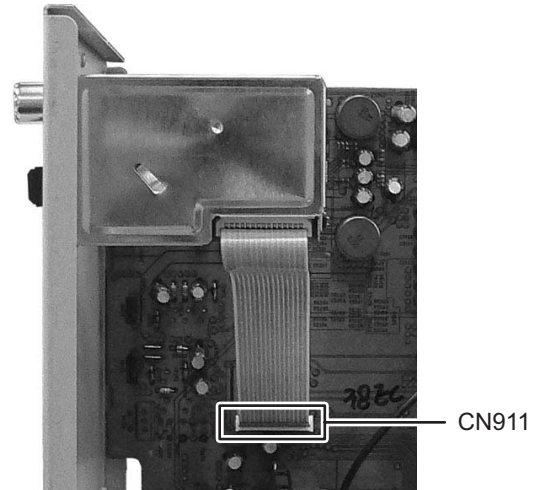

Fig.6

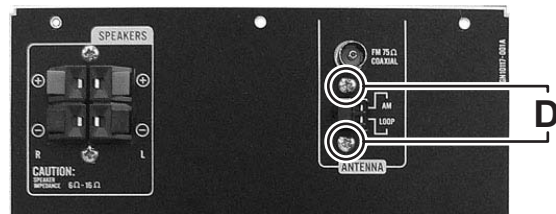

Fig.7

### 3.1.4 Removing the Rear Panel (See Fig.8, 9)

- (1) Remove the two screws **E** attaching the Speaker terminal. (See Fig.8)
- (2) Remove the two screws **F** attaching the Power board assembly. (See Fig.8)
- (3) Disengage the hook **c** engaged both side of Rear panel. (See Fig.9)

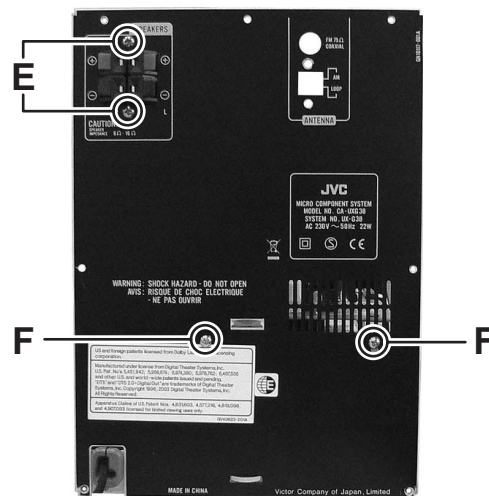

Fig.8

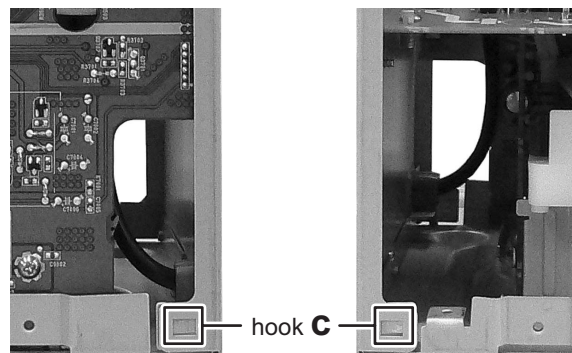

Fig.9

### 3.1.5 Removing the Main board assembly (See Fig.10)

- (1) Remove the one screw **G** attaching the Main board assembly.
- (2) Disconnect the connector **CN373** and **CN709** connected Main board assembly and Power board assembly.
- (3) Disconnect the connector **CN401** connected Main board assembly and Jack board assembly.
- (4) Disconnect the connector wire from CD mechanism assembly connected to connector **CN708** of the Main board assembly.

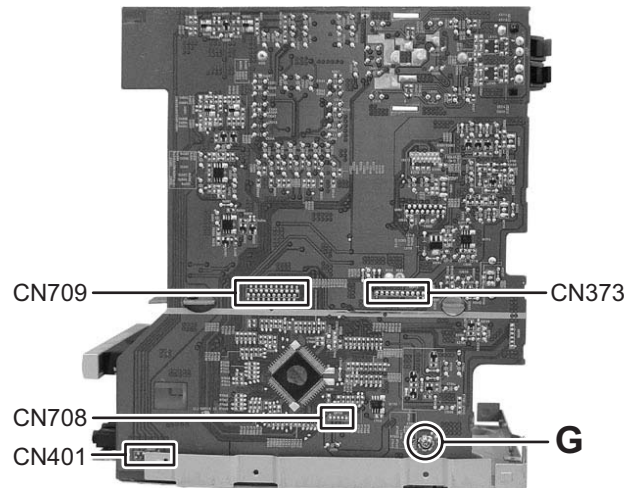

Fig.10

### 3.1.6 Removing the Power board assembly (See Fig.11)

- (1) Disconnect the card wire from DVD mechanism assembly connected to connector **CN701** of the Power board assembly.
- (2) Remove the two screws **H** attaching the Power board assembly.
- (3) The slide is done, and it pulls and it raises it in the direction of the arrow.

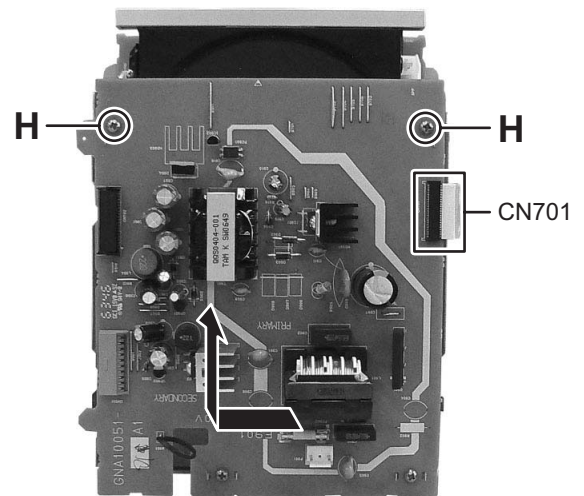

Fig.11

### 3.1.7 Removing the CD mechanism assembly (See Fig.12, 13)

- (1) Remove the one screw **J** attaching the CD mechanism assembly. (See Fig.12)
- (2) Turnover the CD mechanism, disconnect the connector wire from CD mechanism assembly connected to connector **CN104** of the Jack board assembly. (See Fig.13)

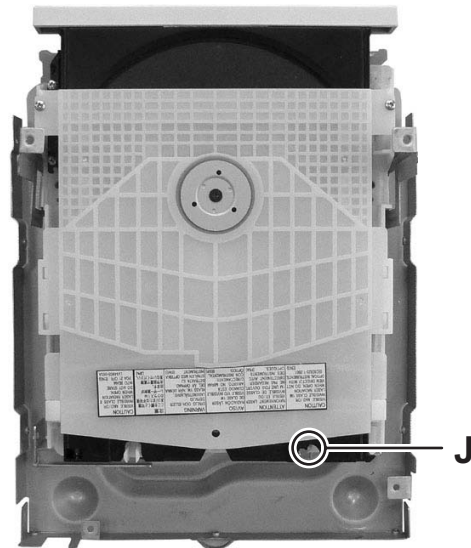

Fig.12

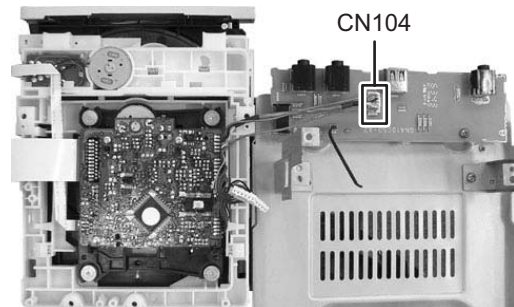

Fig.13

### 3.1.8 Removing the Front board assembly (See Fig.14)

- (1) Remove the volume knob.
- (2) Remove the eleven screws **K** attaching the Front board assembly.

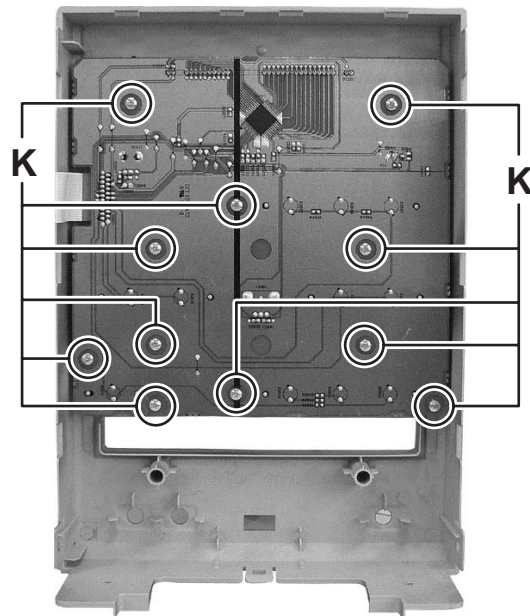

Fig.14

### 3.2 CD mechanism assembly

- Remove the CD mechanism assembly from main body.

#### 3.2.1 Removing the CD cover

(See Fig.1)

- (1) Remove the two screws **A** attaching the CD cover from bottom side of CD mechanism assembly.
- (2) Lift up the CD cover from disengage boss **a** of the CD mechanism assembly.
- (3) Slide the CD cover to direction of the arrow and remove the CD cover from fixing part **b**.
- (4) Remove the CD cover.

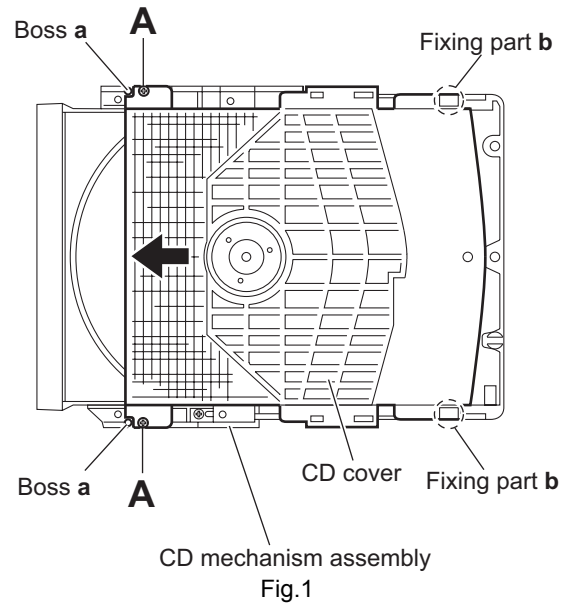

#### 3.2.2 Removing the tray assembly

(See Fig.2 and 3)

- Remove the CD cover.
- (1) Press slide cam and pull out the tray assembly to direction of the arrow from right side of CD mechanism assembly. (See Fig.2)
- (2) Remove the two screws **B** attaching the tray assembly from upper side of CD mechanism. (See Fig.3)
- (3) Remove the bussing of the tray assembly from boss **c** of the CD mechanism assembly and remove the tray assembly. (See Fig.3)

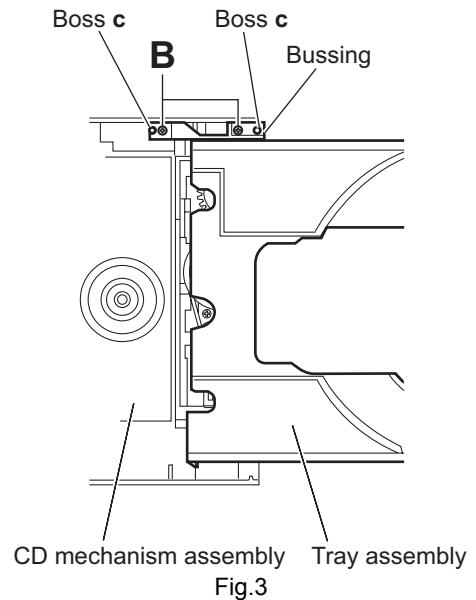
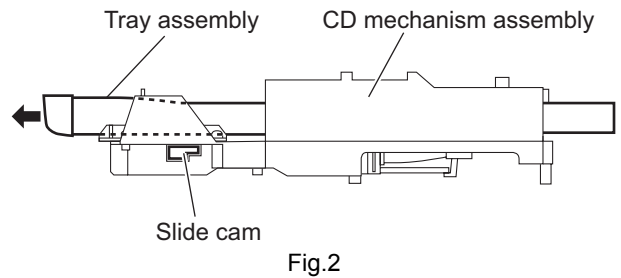

### 3.2.3 Removing the traverse mechanism assembly (See Fig.4)

- (1) Remove the four screws **C** attaching the traverse mechanism assembly from bottom side of CD mechanism assembly.
- (2) Disconnect the card wire from connector [CN602](#) of the CD servo board and then take out the traverse mechanism assembly and CD servo board together.

#### Reference:

When reattaching the traverse mechanism assembly, the card wire should through the part **d**.

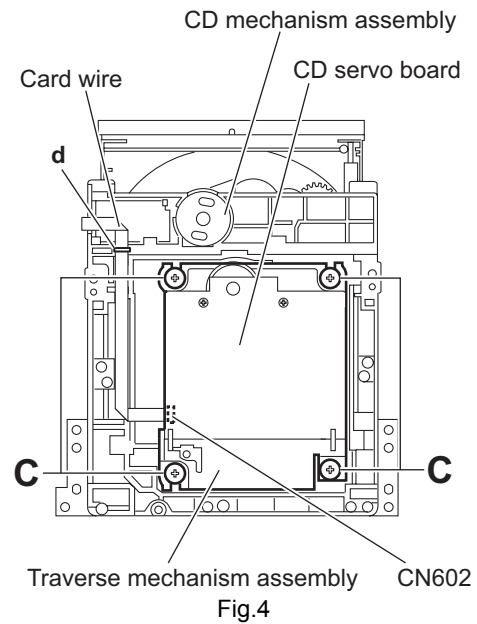

### 3.2.4 Removing the CD servo board (See Fig.5 and 6)

- Remove the traverse mechanism assembly.
  - (1) Remove the two screws **D** attaching the CD servo board from bottom side of traverse mechanism assembly. (See Fig.5)
  - (2) Remove the solder from solder part **e** of the CD servo board. (See Fig.5)
  - (3) Remove the yellow wire from solder part **f** of the CD servo board. (See Fig.5)
  - (4) Remove the white wire from solder part **h** of the CD servo board. (See Fig.5)
  - (5) Remove the CD servo board to upper side, disengage the hook **c** to direction of the arrow 1 then turn over the CD servo board. (See Fig.5)
  - (6) Solder to short land part **j** of pickup. (See Fig.6)
  - (7) Release the lock of connector **CN601** to direction of the arrow 2 and disengage the card wire. (See Fig.6)

#### Caution:

- Solder to short land part **j** of the pickup then disconnect the card wire from connector **CN601** of the CD servo board. If disconnect the card wire before soldering, pickup is make sure destroyed by static electricity. (See Fig.6)
- When reattaching the CD servo board, connect the card wire to connector **CN601** and then remove the solder of short land part **j** of the pickup.

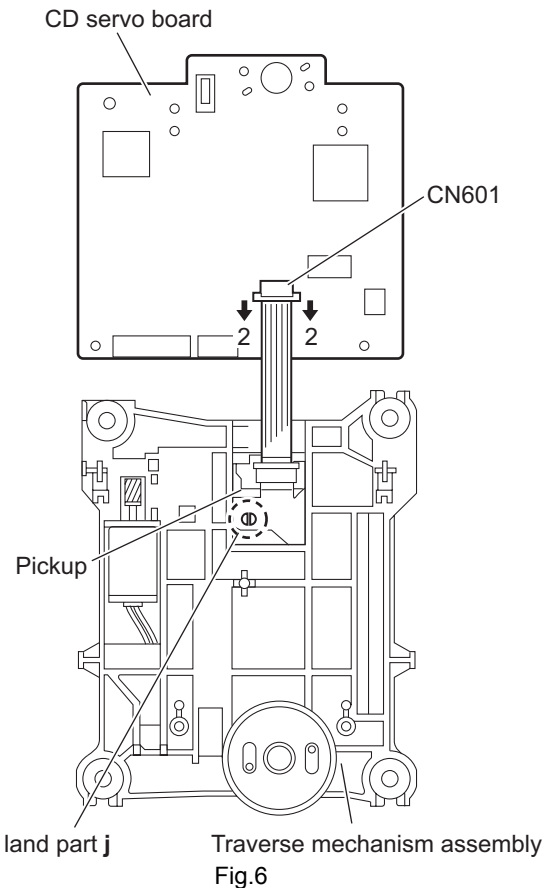
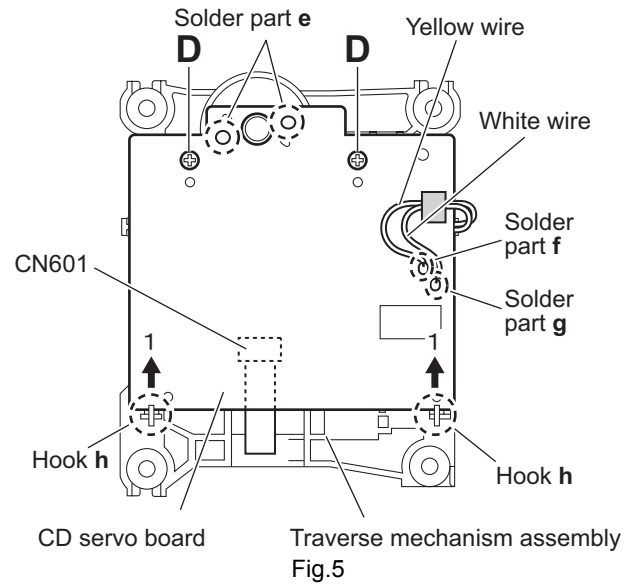

### 3.2.5 Removing the pickup (See Fig.7 to 9)

- Remove the traverse mechanism assembly.
  - (1) Remove the one screw **E** attaching the plate from upper side of traverse mechanism assembly. (See Fig.7)
  - (2) Remove the plate from fixing part **k** then take out the plate. (See Fig.7)
  - (3) Remove the two screws **F** attaching the LEAD spring and then take out the LEAD spring. (See Fig.8)
  - (4) Take out the feed gear, and then remove the shaft of pickup from part **m** of the traverse mechanism assembly. (See Fig.8)
  - (5) Remove the pickup from part **n** of the traverse mechanism assembly and then take out pickup with shaft. (See Fig.8)
  - (6) Release the shaft from pickup. (See Fig.8)
  - (7) Solder the short land part **p** of the pickup. (See Fig.9)
  - (8) Release the lock of the connector to direction of the arrow, and then disconnect the card wire. (See Fig.9)

#### Caution:

- Solder to short land part **p** of the pickup then disconnect the card wire from connector. If disconnect the card wire before soldering, pickup is make sure destroyed by static electricity. (See Fig.9)
- When reattaching the pickup, connect the card wire to connector and then remove the solder from short land part **p**. (See Fig.9)

### 3.2.6 Attaching the pickup (See Fig.7 to 10)

- Please refer the "Removing the pickup".
  - (1) Connect the card wire to connector of pickup, and then remove the solder from short land part **p** of the pickup. (See Fig.9)
  - (2) Attach the shaft to pickup. (See Fig.8)
  - (3) Fit the pickup to part **n** of the traverse mechanism and then attach the end of the shaft to part **k**. (See Fig.8)
  - (4) Attach the LEAD spring and feed gear. (See Fig.8)
  - (5) Attach the plate. (See Fig. 7)
  - (6) One turn the LEAD gear to direction of the arrow 1 and fully shift to direction of the arrow 2. (See Fig.10)

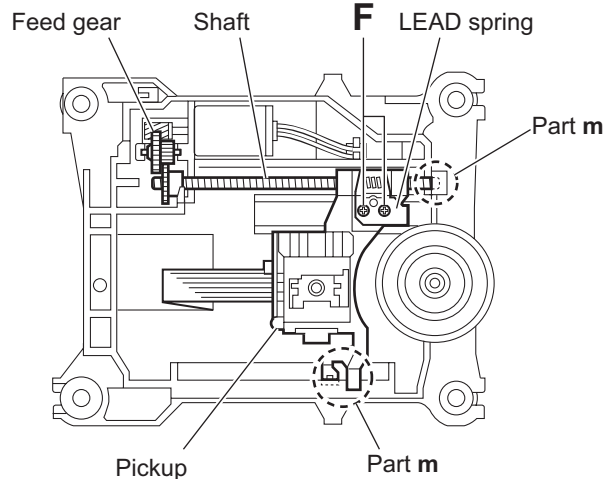

Fig.8

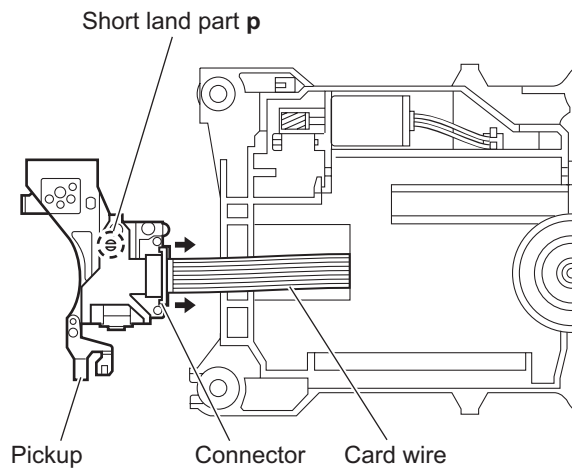
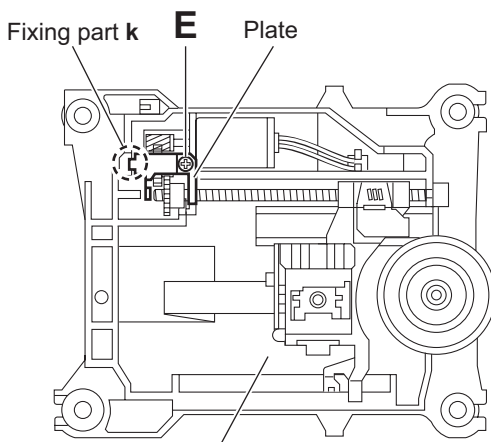

Fig.9



Traverse mechanism assembly  
Fig.7

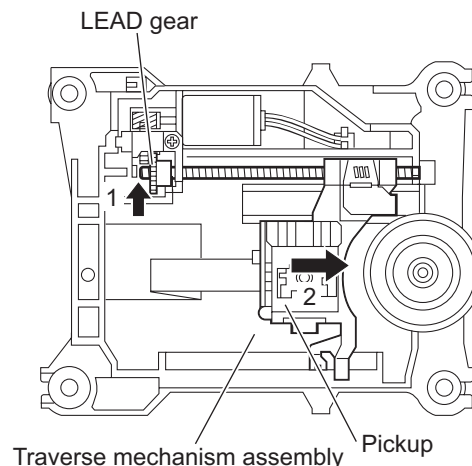

Fig.10

### 3.2.7 Removing the feed motor (See Fig.11 to 13)

- Remove the traverse mechanism.
  - (1) Remove the yellow wire from solder part **q** of the CD servo board from upper side of traverse mechanism. (See Fig.11)
  - (2) Remove the white wire from solder part **r** of the CD servo board. (See Fig.11)
  - (3) Remove the one screw **G** attaching the plate. (See Fig.12)
  - (4) Disengage the plate from fixing part **s** and take out the plate. (See Fig.12)
  - (5) Remove the feed gear and take out the feed motor. (See Fig.13)

#### Reference:

When attaching the feed motor, the wire has to through the part **t** of the traverse mechanism assembly. (See Fig.13)

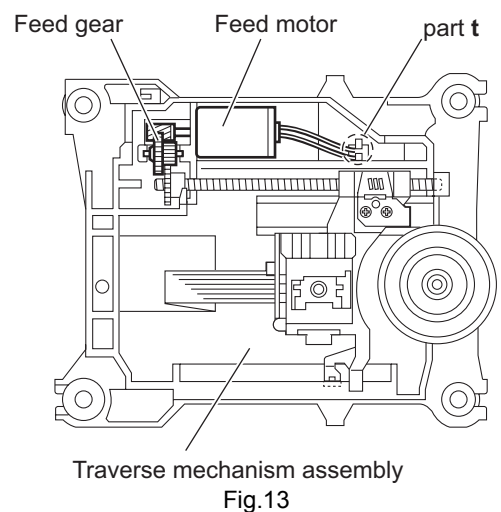
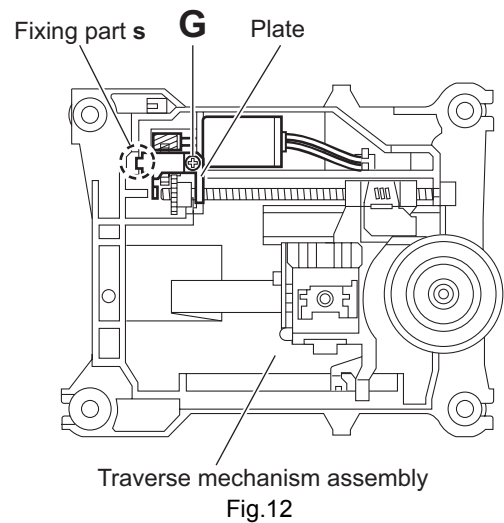
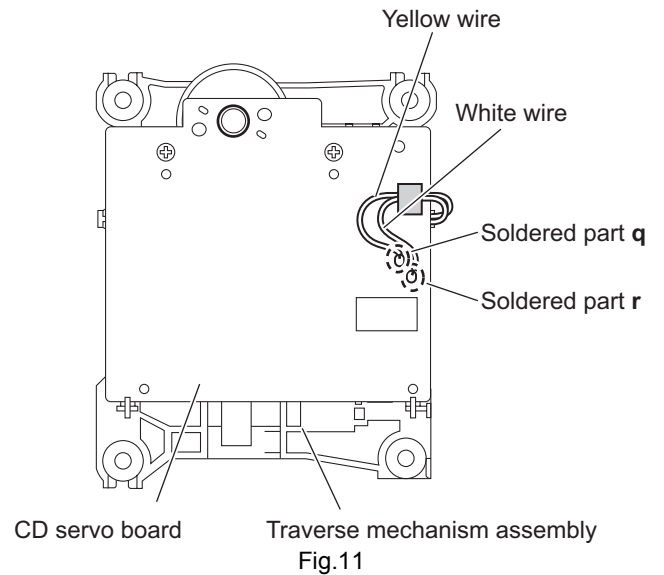

### 3.2.8 Removing the switch board (See Fig.14)

- (1) Disconnect the card wire from **CN1** of the switch board from bottom side of CD mechanism assembly.
- (2) Remove the wire from solder part **u** of the switch board.
- (3) Remove the one screw **H** attaching the switch board to CD mechanism assembly.
- (4) Lift up the switch board by pushing the hook **v** of CD mechanism assembly and take out it from part **w**.

#### Reference:

- After attach the switch board to CD mechanism assembly, wire hooked to part **x**.
- Hook **u** of the CD mechanism assembly, it have to bond lock.

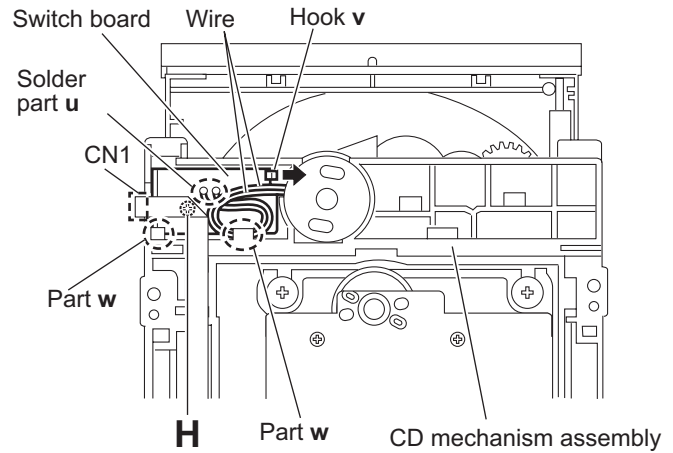

Fig.14

### 3.2.9 Removing the motor (See Fig.14 and 15)

- Remove the tray assembly.

- (1) Remove the wire from solder part **u** of the switch board from bottom side of CD mechanism assembly.
- (2) Remove the belt of motor pulley from upper side of CD mechanism assembly. (See Fig.15)

#### Caution:

Belt should not apply grease.

- (3) Remove the two screws **J** attaching the motor to CD mechanism assembly and take out the motor from bottom side of CD mechanism assembly. (See Fig.15)

#### Reference:

After motor attached to CD mechanism assembly, wire should hook to part **w**. (See Fig.14)

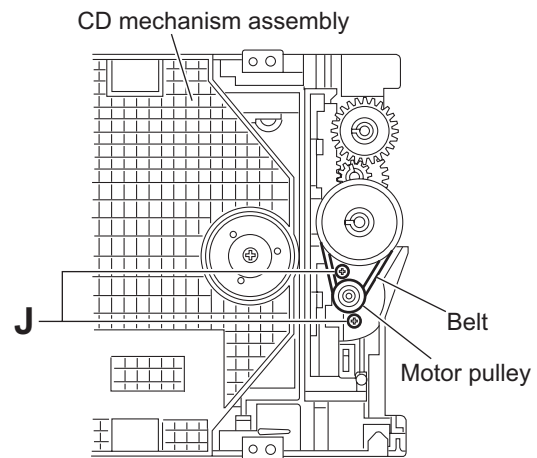

Fig.15

## SECTION 4 ADJUSTMENT

### 4.1 TEST MODE

BUTTON	INDICATION	FUNCTION
[POWER] + [SET] + [REPEAT]	COLD	COLD START (Initialization of set)
[POWER] + [SET] + [FM MODE/PLAY MODE]	V_E_RDS	Version indication
[POWER] + [SET] + [S.TURBO]	(FL ALL DISPLAY)	FL all display
[POWER] + [SET] + [FADE MUTING]	VOL MAX	Volume level to max by compulsion.
[POWER] + [SET] + [BASS/TREBLE]	V_E_RDS → MG38_256 → 1129B FF → R,1.29.00	Micon version indication Whenever the button is pushed, the display replaces it.
[POWER] + [SET] + [SLEEP]	(CLOCK FAST FORWARD)	Clock minute fast increase by 1 every seconds.

## SECTION 5 TROUBLESHOOTING

This service manual does not describe TROUBLESHOOTING.



# JVC

Victor company of Japan, Limited  
Audio/Video Systems category 10-1,1chome,Ohwatari-machi,Maebashi-city,Gumma-ken, 371-8543,Japan

---

(No.MB611)



In regard with component parts appearing on the silk-screen printed side (parts side) of the PWB diagrams, the parts that are printed over with black such as the resistor (■), diode (▣) and ICP (●) or identified by the "⚠" mark nearby are critical for safety.

# Block diagram

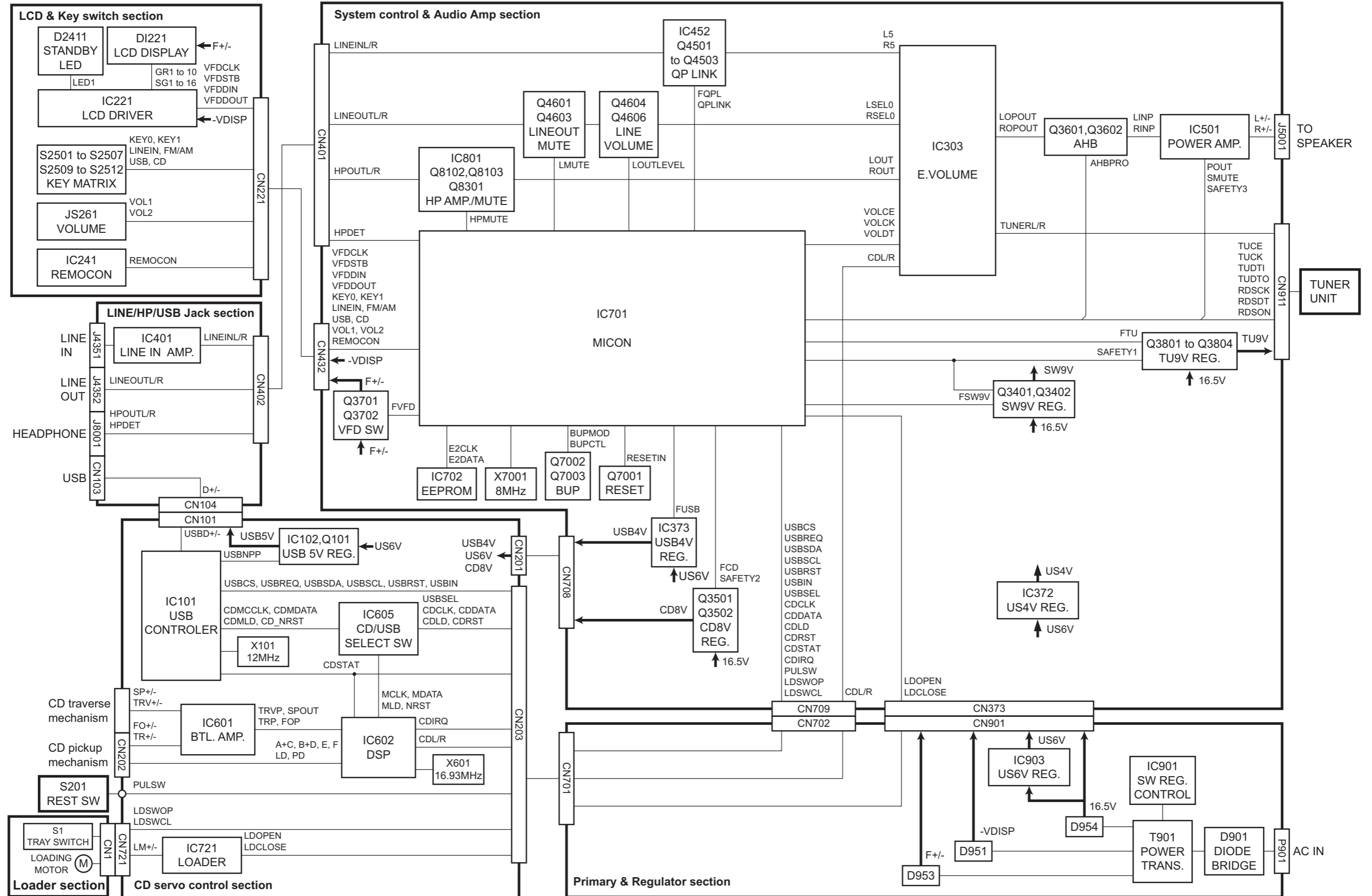

# Standard schematic diagrams

## Primary section

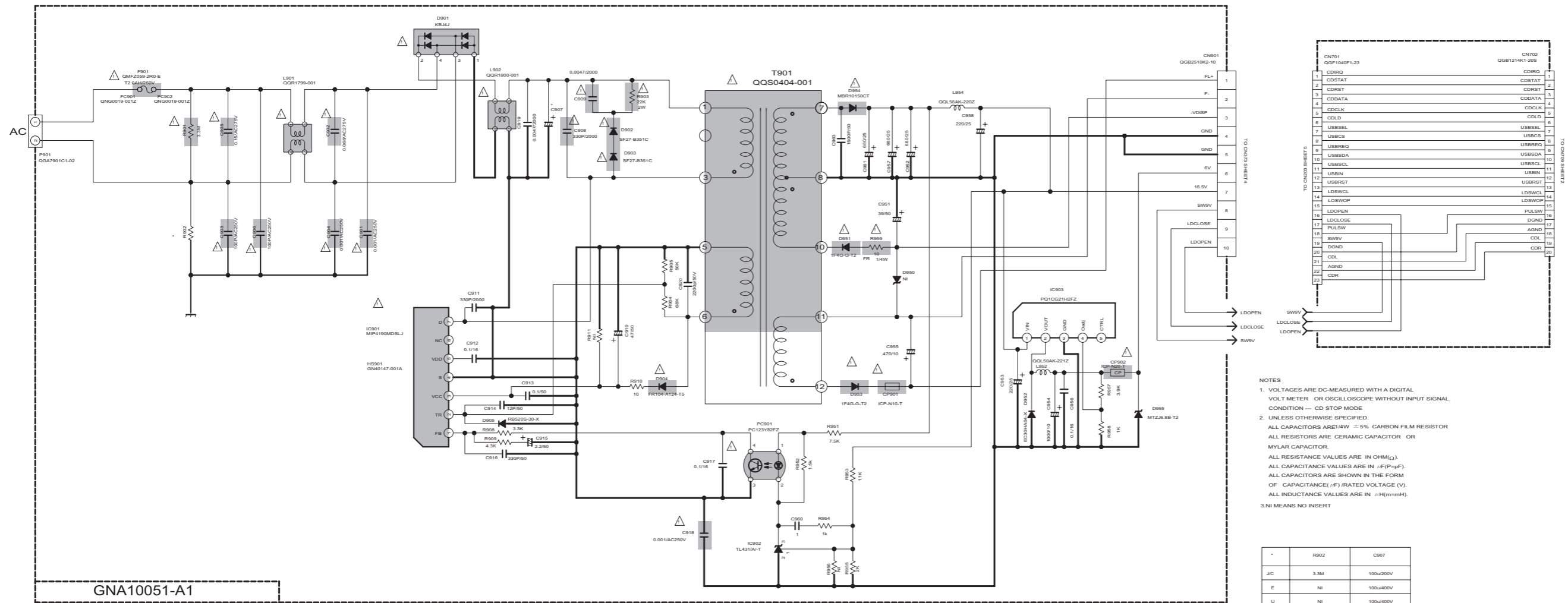

- NOTES
1. VOLTAGES ARE DC-MEASURED WITH A DIGITAL VOLT METER OR OSCILLOSCOPE WITHOUT INPUT SIGNAL. CONDITION — CD STOP MODE.
  2. UNLESS OTHERWISE SPECIFIED, ALL CAPACITORS ARE  $\pm 5\%$  CARBON FILM RESISTOR ALL RESISTORS ARE CERAMIC CAPACITOR OR MYLAR CAPACITOR. ALL RESISTANCE VALUES ARE IN  $\Omega$ (M), ALL CAPACITANCE VALUES ARE IN  $\mu$ (F)(P)(F). ALL CAPACITORS ARE SHOWN IN THE FORM OF CAPACITANCE(,F)/RATED VOLTAGE (V). ALL INDUCTANCE VALUES ARE IN  $\mu$ (H)(m-mH).
  3. NI MEANS NO INSERT

*	R902	C907
J/C	3.3M	100 $\mu$ 200V
E	NI	100 $\mu$ 400V
U	NI	100 $\mu$ 400V

⚠ Parts are safety assurance parts. When replacing those parts make sure to use the specified one.

Micon section

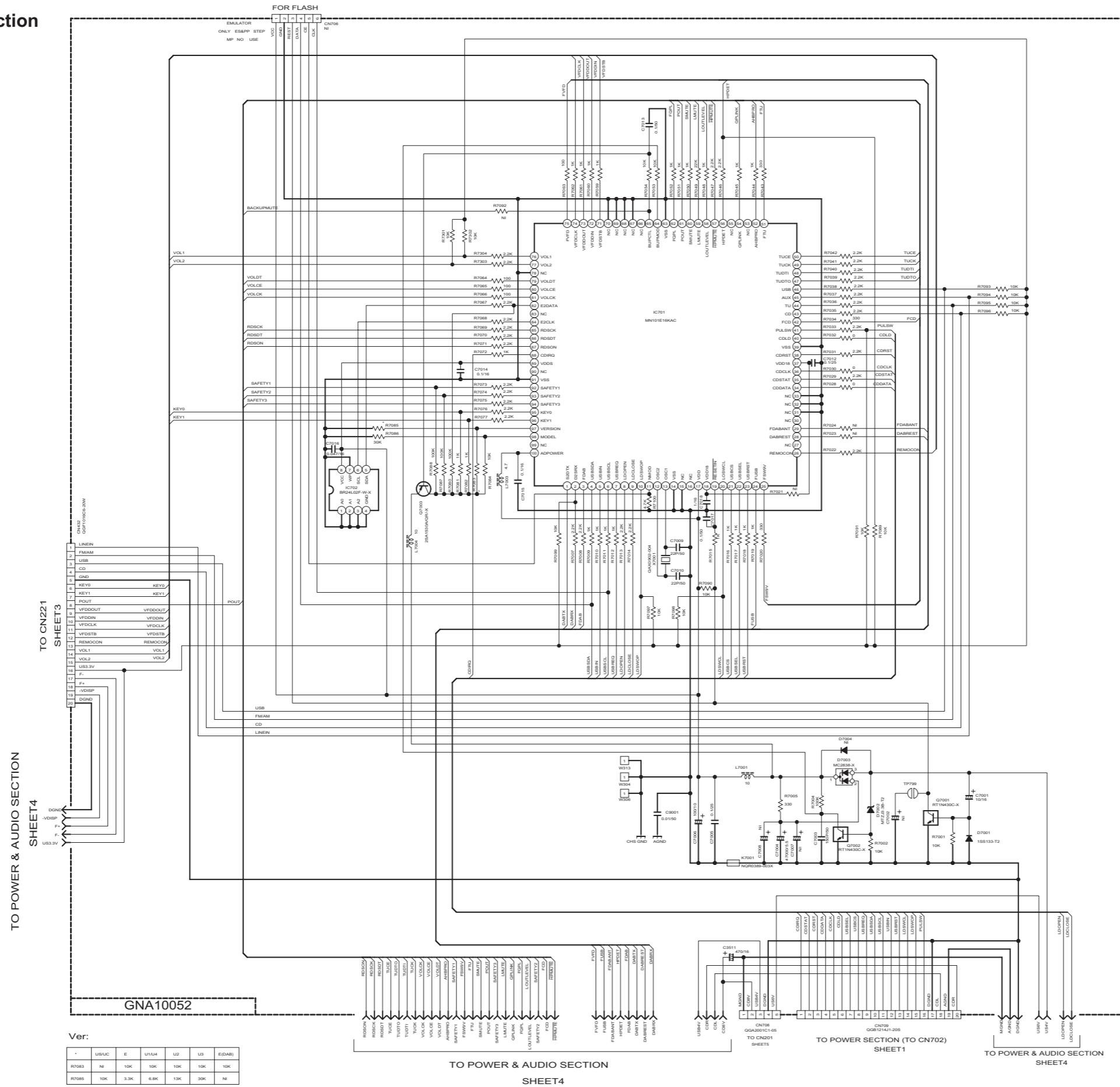

NOTES  
 1. VOLTAGES ARE DC-MEASURED WITH A DIGITAL VOLT METER OR OSCILLOSCOPE WITHOUT INPUT SIGNAL. CONDITION — CD STOP MODE.  
 2. UNLESS OTHERWISE SPECIFIED, ALL RESISTORS ARE 1/4W ±5% CARBON FILM RESISTOR. ALL CAPACITORS ARE CERAMIC CAPACITOR OR MYLAR CAPACITOR. ALL RESISTANCE VALUES ARE IN OHM(Ω). ALL CAPACITANCE VALUES ARE IN μF(μF). ALL CAPACITORS ARE SHOWN IN THE FORM OF CAPACITANCE(μF) RATED VOLTAGE (V). ALL INDUCTANCE VALUES ARE IN mH(mH).  
 3. NI MEANS NO INSERT.  
 4. DIGITAL TRANSISTOR



# Audio section

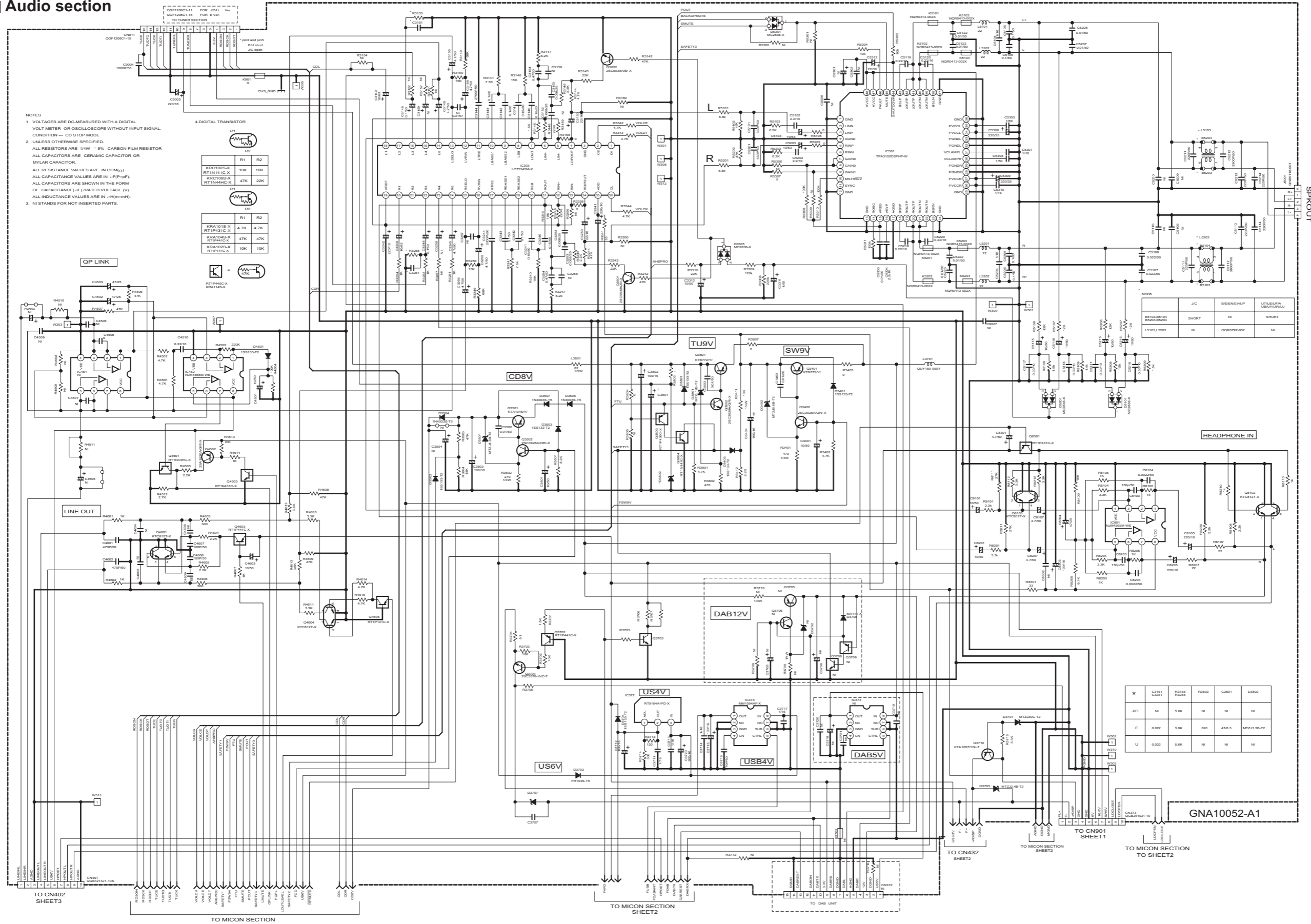

- NOTES
- VOLTAGES ARE DC-MEASURED WITH A DIGITAL VOLT METER OR OSCILLOSCOPE WITHOUT INPUT SIGNAL. CONDITION — CD STOP MODE.
  - UNLESS OTHERWISE SPECIFIED, ALL RESISTORS ARE 1/4W ±5% CARBON FILM RESISTOR. ALL CAPACITORS ARE CERAMIC CAPACITOR OR MYLAR CAPACITOR.
  - ALL RESISTANCE VALUES ARE IN OHM(Ω), ALL CAPACITANCE VALUES ARE IN pF(pF), ALL CAPACITORS ARE SHOWN IN THE FORM OF CAPACITANCE-(P) RATED VOLTAGE (V), ALL INDUCTANCE VALUES ARE IN mH(mH).
  - NI STANDS FOR NOT-INSERTED PARTS.

4-DIGITAL TRANSISTOR

R1	R2
KRC1023-X	10K 10K
RT1841C-X	4.7K 4.7K
KRA1048-X	47K 47K
RT1841C-X	10K 10K

R1	R2
KRA1018-X	4.7K 4.7K
RT1841C-X	4.7K 4.7K
KRA1048-X	47K 47K
KRA1028-X	10K 10K
RT1841C-X	10K 10K

MARK

JTC	BEENEVLP	LTUSLUPA
B3103.B3104	NI	SHORT
B3103.B3104	SHORT	NI
L3103.L3203	NI	GD09797-02

*	C301	R308	R303	C301	C302
JTC	NI	5.6K	NI	NI	NI
E	0.022	3.9K	800	476.3	MTZJ3.3B-T2
LI	0.022	5.6K	NI	NI	NI

CD section

Loader section

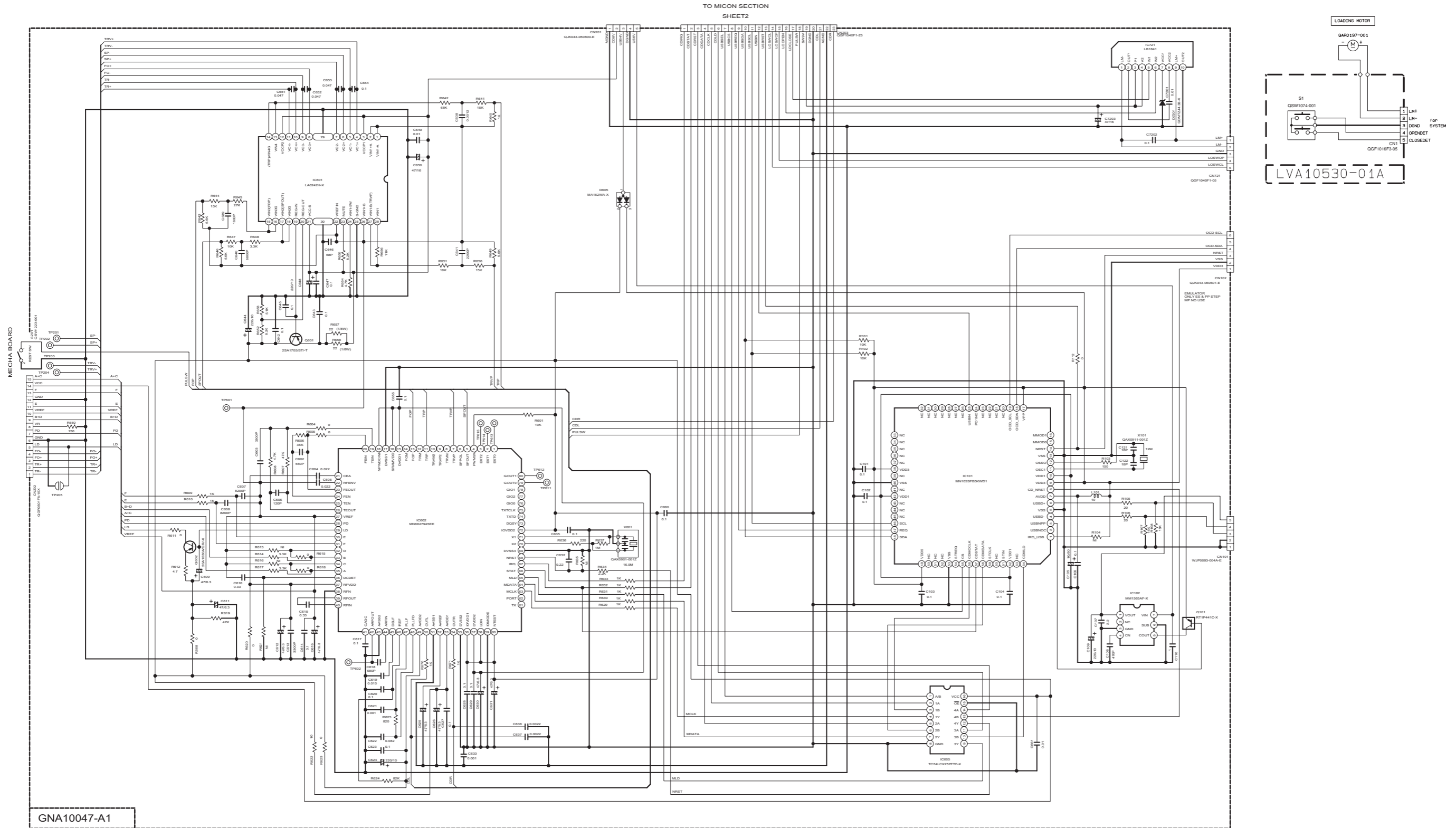

GNA10047-A1

- NOTES
- VOLTAGES ARE DC-MEASURED WITH A DIGITAL VOLT METER OR OSCILLOSCOPE WITHOUT INPUT SIGNAL. CONDITION --- CD STOP MODE
  - UNLESS OTHERWISE SPECIFIED, ALL RESISTORS ARE 1/4W ±5% CARBON FILM RESISTOR ALL CAPACITORS ARE CERAMIC CAPACITOR OR MYLAR CAPACITOR. ALL RESISTANCE VALUES ARE IN OHM(Ω). ALL CAPACITANCE VALUES ARE IN -F(P=PF). ALL CAPACITORS ARE SHOWN IN THE FORM OF CAPACITANCE(-F) RATED VOLTAGE (V). ALL INDUCTANCE VALUES ARE IN -H(M=MH). 3.NI MEANS NO INSERT
4. DIGITAL TRANSISTOR
- 47K
- 47K





■ **CD board** Lead free solder used in the board (material : Sn-Ag-Cu, melting point : 219 Centigrade)

Lead free solder used in the board (material : Sn-Cu, melting point : 230 Centigrade)

forward side

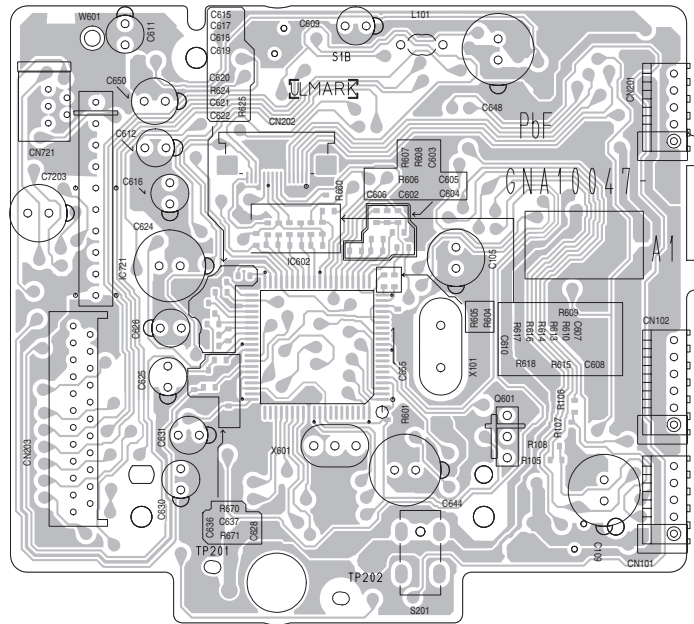

**JVC**

Victor Company of Japan, Limited

Audio/Video Systems Category 10-1, 1chome, Ohwatari-machi, Maebashi-city, 371-8543, Japan

(No.MB611SCH)



Printed in Japan  
VPT

# PARTS LIST

UX-G38B,UX-G38E,UX-G38EN  
UX-G38EV,UX-G39E,UX-G39EN  
UX-G39EV,UX-G37B,UX-G37E  
UX-G37EN,UX-G37EV

- \* All printed circuit boards and its assemblies are not available as service parts.
- \* UX-G39 is derivative model and different color model of UX-G38.
- \* UX-G37 is different color model of UX-G38.

## - Contents -

Exploded view of general assembly and parts list (Block No.M1) .....	3- 2
CD mechanism assembly and parts list (Block No.MB) .....	3- 5
CD loading base assembly and parts list (Block No.MD) .....	3- 7
Electrical parts list (Block No.01~04) .....	3- 9
Packing materials and accessories parts list (Block No.M3) .....	3-16

# Exploded view of general assembly and parts list

Block No. **M** **1** **M** **M**

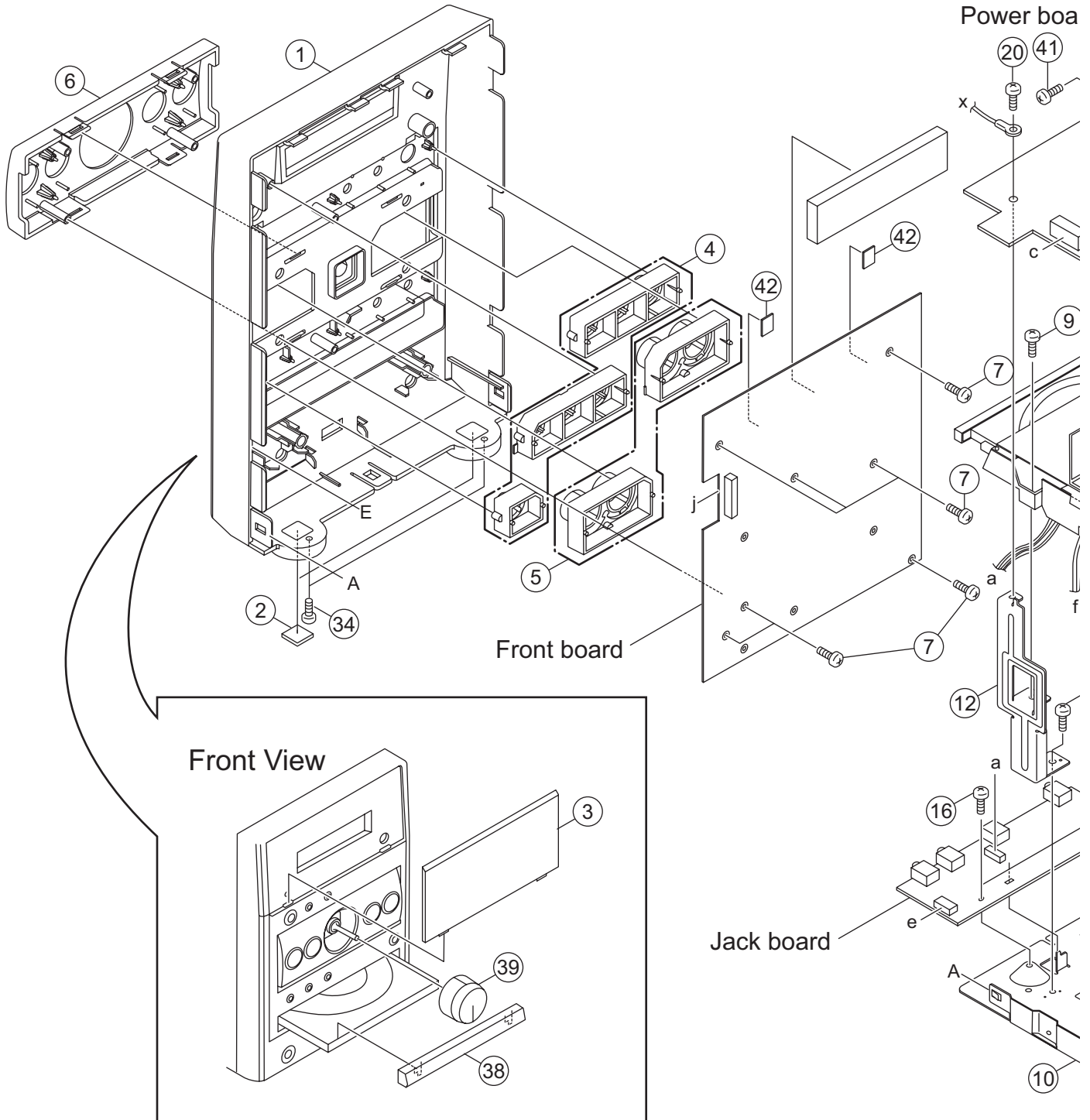

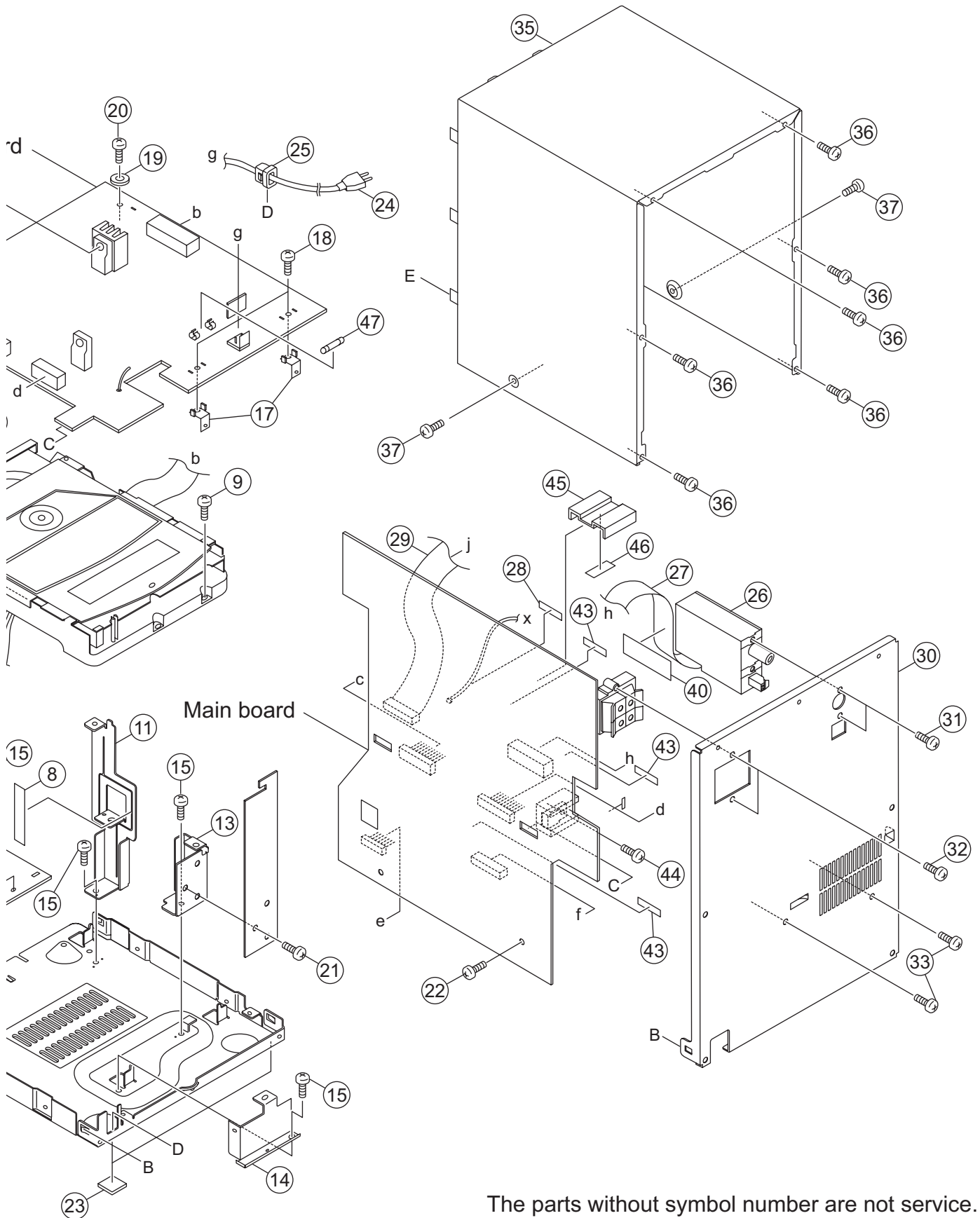

The parts without symbol number are not service.

# General Assembly

Block No. [M][1][M][M]

△	Symbol No.	Part No.	Part Name	Description	Local
	1	GN10115-002A	FRONT PANEL		G38B,G38E,G38EN,G38EV, G39E,G39EN,G39EV
	1	GN10115-006A	FRONT PANEL		G37B,G37E,G37EN,G37EV
	2	GV40780-001A	FELT SPACER	(x2)	
	3	GN20222-001A	WINDOW SCREEN		G38B,G38E,G38EN,G38EV
	3	GN20222-003A	WINDOW SCREEN		G39E,G39EN,G39EV
	3	GN20222-006A	WINDOW SCREEN		G37B,G37E,G37EN,G37EV
	4	GN20223-001A	PUSH BUTTON		G38B,G38E,G38EN,G38EV, G39E,G39EN,G39EV
	4	GN20223-002A	PUSH BUTTON		G37B,G37E,G37EN,G37EV
	5	GN20225-001A	PUSH BUTTON		G38B,G38E,G38EN,G38EV, G39E,G39EN,G39EV
	5	GN20225-005A	PUSH BUTTON		G37B,G37E,G37EN,G37EV
	6	GN20226-001A	ORNAMENT		G38B,G38E,G38EN,G38EV, G39E,G39EN,G39EV
	6	GN20226-002A	ORNAMENT		G37B,G37E,G37EN,G37EV
	7	QYSDSF2608ZA	TAP SCREW	(x7)	
	8	GV30349-050A	SPACER		
	9	QYSDSG3008ZA	TAP SCREW	(x2)	
	10	GN10116-002A	BOTTOM CHASSIS		
	11	GN30213-001A	BRACKET A		
	12	GN30214-001A	BRACKET B		
	13	GN30236-001A	BRACKET C		
	14	GN30235-001A	BRACKET D		
	15	QYSBSG3006EA	TAP SCREW	(x4)	
	16	QYSDSG3008ZA	TAP SCREW	(x2)	
	17	GN30237-001A	BRACKET E	(x2)	
	18	QYSDSG3008ZA	TAP SCREW	(x2)	
	19	GV30792-005A	SPACER PC		
	20	QYSDSG3008ZA	TAP SCREW	(x2)	
	21	QYSBSGY3008EA	TAP SCREW		
	22	QYSBSGY3008EA	TAP SCREW		
	23	GV40764-001A	FOOT SPACER	(x2)	
△	24	QMPN410-200-JD	POWER CORD(EU)	2m BLACK	G38B,G37B
△	24	QMPK200-200-JD	POWER CORD(EU)	2m BLACK	G38E,G38EN,G38EV,G39E,G39EN, G39EV,G37E,G37EN,G37EV
	25	QZW0033-001	STRAIN RELIEF		
	26	QAU0473-001	TUNER		
	27	QUQU12-1519BJ-E	FFC WIRE		
	28	GV30349-046A	SPACER		
	29	QUR110-2014AJ-E	FFC WIRE		
	30	GN10117-201A	REAR PANEL		G38B,G38E,G38EN
	30	GN10117-202A	REAR PANEL		G38EV
	30	GN10117-210A	REAR PANEL		G39E,G39EN
	30	GN10117-208A	REAR PANEL		G39EV
	30	GN10117-012A	REAR PANEL		G37B,G37E,G37EN
	30	GN10117-009A	REAR PANEL		G37EV
	31	QYSBSGY3008EA	TAP SCREW	(x2)	
	32	QYSBSGY3008EA	TAP SCREW	(x2)	
	33	QYSBSGY3008EA	TAP SCREW	(x2)	
	34	QYSDSG3008ZA	TAP SCREW	(x2)	
	35	GN20229-003A	METAL COVER		G38B,G38E,G38EN,G38EV, G39E,G39EN,G39EV
	35	GN20229-004A	METAL COVER		G37B,G37E,G37EN,G37EV
	36	QYSBSGY3008EA	TAP SCREW	(x6)	
	37	QYSDSG3008NA	TAP SCREW	(x2)	
	38	GN30216-001A	TRAY FITTING		G38B,G38E,G38EN,G38EV, G39E,G39EN,G39EV
	38	GN30216-002A	TRAY FITTING		G37B,G37E,G37EN,G37EV
	39	GN30217-001A	VOLUME KNOB		
	40	GV30349-084A	SPACER		
	41	QYSBSG3010ZA	TAP SCREW		
	42	GV30349-021A	SPACER	(x2)	
	43	GV30349-050A	SPACER	(x3)	
	44	QYSBST3008ZA	TAP SCREW		
	45	GV31088-001A	HEAT SINK		
	46	GV40791-001A	THERMAL SHEET		
△	47	QMFZ059-2R0-E	FUSE		

# CD mechanism assembly and parts list

Block No. **M** **B** **M** **M**

Grease	
★	JVG-31N
●	JVS-1003
▲	FL-7750E
■	E-460

GTU-MS1-12M

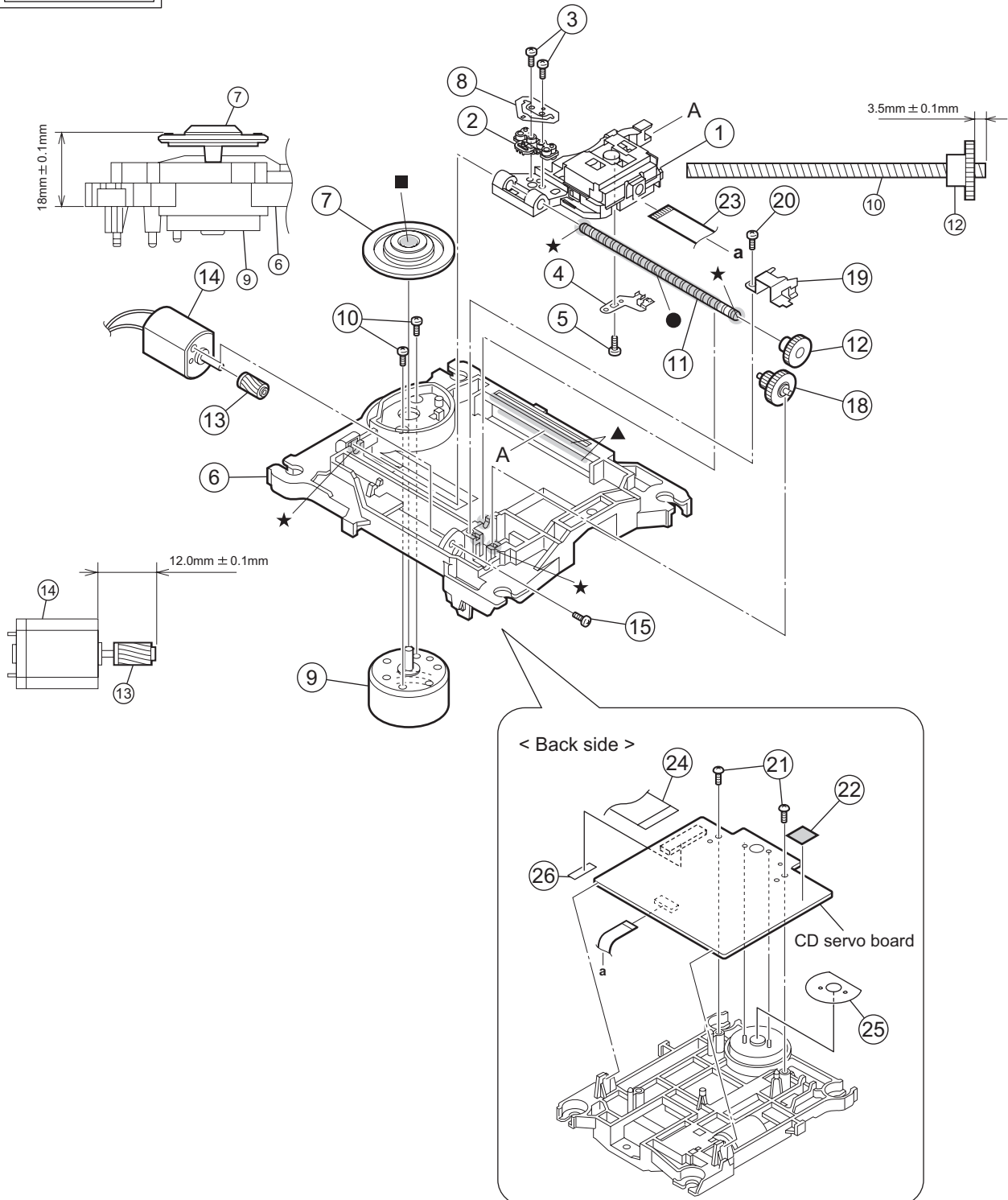

The parts without symbol number are not service.

## CD mechanism

Block No. [M][B][M][M]

△	Symbol No.	Part No.	Part Name	Description	Local
	1	QAL0844-001	PICK UP		
	2	LV22529-002A	RACK ARM		
	3	VKZ4777-012	MINI SCREW	(x2)	
	4	LV37574-001A	RACK ARM SPRING		
	5	QYSPSGT1425MA	TAP SCREW	M1.4 x 2.5mm	
	6	LV10855-004A	TM CHASSIS		
	7	LV43648-001A	TURN TABLE		
	8	LV31744-001A	P.S.SPRING		
	9	QAR0302-001	SPINDLE MOTOR	2.0V DC	
	10	VKZ4743-002	SPECIAL SCREW	(x2)	
	11	LV40157-001A	SCREW SHAFT		
	12	LV43651-001A	SS GEAR		
	13	LV43650-001A	F MOTOR GEAR		
	14	QAR0303-001	FEED MOTOR	2.0V DC	
	15	QYSPSPT2030MA	SCREW	M2 x 3mm	
	18	LV34565-003A	F MIDDLE GEAR		
	19	LV34563-001A	SHAFT HOLDER		
	20	QYSPSFT1740ZA	TAP SCREW	M1.7 x 4mm	
	21	QYSBSF2006ZA	TAP SCREW	M2 x 6mm(x2)	
	22	LV30225-073A	SPACER		
	23	QUQU05-1506BB-E	FFC WIRE	15pin 6cm	
	24	QUR110-2313BJ-E	FFC WIRE		
	25	GV40774-002A	COVER SHEET		
	26	LV30225-0F4A	SPACER		

# CD loading base assembly and parts list

GMU-MS1-12M

Block No. M D M M

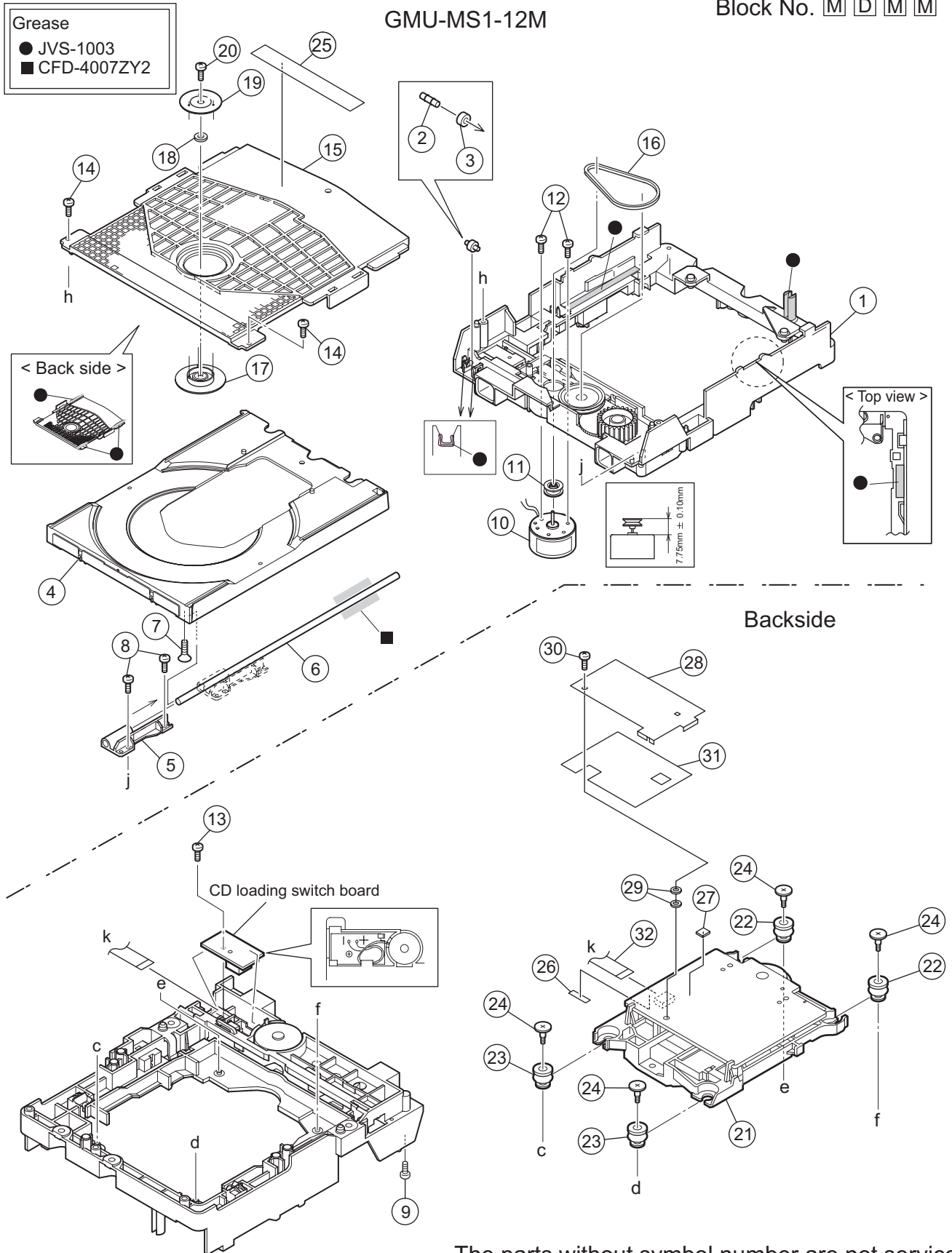

# CD loading base

Block No. [M][D][M][M]

△	Symbol No.	Part No.	Part Name	Description	Local
	1	LV11065-010A	LOADER SUB ASSY		
	2	E407140-001SS	C.D ROLLER		
	3	E407149-001SS	RUBBER TUBE		
	4	LV10979-003A	TRAY		
	5	LV35499-003A	SHAFT GUIDE		
	6	LV44022-001A	SHAFT		
	7	QYSSSF2008ZA	TAP SCREW	M2 x 8mm	
	8	QYSDSF2008ZA	TAP SCREW	M2 x 8mm(x2)	
	9	LV41741-004A	SPECIAL SCREW		
	10	QAR0197-001	MOTOR	2.0V DC	
	10	or QAR0450-001	MOTOR		
	11	LV43844-002A	MOTOR PULLEY		
	12	QYSPSPU1730ZA	SCREW	M1.7 x 3mm(x2)	
	13	QYSDSF2008ZA	TAP SCREW	M2 x 8mm	
	14	QYSDSF2008ZA	TAP SCREW	M2 x 8mm(x2)	
	15	LV21852-003A	CLAMPER BASE		
	16	LV43974-001A	BELT		
	17	LV34586-002A	CD CLAMPER		
	18	LV42930-003A	P.C.MAGNET		
	19	LV43848-001A	YOKE		
	20	LV43958-001A	SPECIAL SCREW		
	21	-----	CD TRAMECHA UNI		
	22	LV44043-001A	INSULATOR	(x2)	
	23	LV44043-002A	INSULATOR	(x2)	
	24	LV44044-001A	SPECIAL SCREW	(x4)	
	25	LV44603-003A	LASER CAUTION		
	26	LV30225-0V6A	SPACER		
	27	GV30349-081A	SPACER		
	28	GV40776-001A	BRACKET		
	29	GV30792-004A	SPACER	(x2)	
	30	QYSBSF2008ZA	TAP SCREW	M2 x 8mm	
	31	GV40789-002A	SPACER		
	32	LV43805-002A	FFC		

# Electrical parts list

## Power board

Block No. [0][1]

Symbol No.	Part No.	Part Name	Description	Local
	IC221	PT6315	IC	
	IC241	NJL23H380A-E	IC	
	IC401	NJM4565M-WE	IC	
△	IC901	MIP4190MDSLJ	IC	
	IC902	KIA431A-T	IC	
	IC903	PQ1CG21H2FZ	IC	
	D101	STZC6.8N-X	USB ESD DIODE	
△	D901	KBJ4J	BRIDGE DIODE	
△	D902	SF27-B351C	FR DIODE	
	D903	SF27-B351C	FR DIODE	
△	D904	FR104-A124-T5	FR DIODE	
	D905	RB520S-30-X	SB DIODE	
△	D951	FR104S-T5	FR DIODE	
	D952	EC30HA04-X	SB DIODE	
△	D953	FR104S-T5	FR DIODE	
△	D954	MBR10150CT	DIODE	
	D955	MTZJ6.8B-T2	Z DIODE	
	D2411	SLR-342VC-T	LED	
△	PC901	PC123Y22FZ	PHOTO COUPLER	
	C111	NCB31HK-182X	C CAPACITOR	
	C112	NCB31HK-182X	C CAPACITOR	
	C114	NDC31HJ-150X	C CAPACITOR	
	C115	NDC31HJ-150X	C CAPACITOR	
	C116	NRSA63J-0R0X	MG RESISTOR	
△	C901	QCZ9134-102	C CAPACITOR	
△	C902	QFZ9073-683	MM CAPACITOR	
△	C903	QCZ9134-101	C CAPACITOR	
△	C904	QCZ9134-102	C CAPACITOR	
△	C905	QFZ9073-154	MM CAPACITOR	
△	C906	QCZ9134-101	C CAPACITOR	
	C907	QEZ0827-107	E CAPACITOR	
△	C908	QCZ0131-331	C CAPACITOR	
△	C909	QCZ0131-472	C CAPACITOR	
	C910	QEZ0658-476Z	E CAPACITOR	
	C911	QCZ0131-331	C CAPACITOR	
	C912	NCB31CK-104X	C CAPACITOR	
	C913	NCB31CK-104X	C CAPACITOR	
	C914	NDC31HJ-120X	C CAPACITOR	
	C915	QETN1HM-225Z	E CAPACITOR	
	C916	NDC31HJ-331X	C CAPACITOR	
	C917	NCB31CK-104X	C CAPACITOR	
△	C918	QCZ9134-102	C CAPACITOR	
	C919	QCZ0131-472	C CAPACITOR	
	C920	NCB31HK-222X	C CAPACITOR	
	C951	QEZ0658-396Z	E CAPACITOR	
	C953	QETN1EM-227Z	E CAPACITOR	
	C954	QEZ0654-108Z	E CAPACITOR	
	C955	QETN1AM-477Z	E CAPACITOR	
	C956	NCB31CK-104X	C CAPACITOR	
	C957	QEZ0656-687Z	E CAPACITOR	
	C958	QETN1EM-227Z	E CAPACITOR	
	C960	NCB31CK-105X	C CAPACITOR	
	C961	QEZ0656-687Z	E CAPACITOR	
	C962	QEZ0656-687Z	E CAPACITOR	
	C2201	NCB31CK-104X	C CAPACITOR	
	C2204	NCB31CK-104X	C CAPACITOR	
	C2205	NCB31HK-223X	C CAPACITOR	
	C2207	NCF31AZ-105X	C CAPACITOR	
	C2209	QERF0JM-107Z	E CAPACITOR	
	C2210	NCB31HK-472X	C CAPACITOR	
	C2601	NCB31HK-103X	C CAPACITOR	
	C2602	NCB31HK-103X	C CAPACITOR	
	C2901	NCF31HZ-103X	C CAPACITOR	
	C4152	NDC31HJ-221X	C CAPACITOR	
	C4252	NDC31HJ-221X	C CAPACITOR	
	C4301	QETN1EM-476Z	E CAPACITOR	
	C4302	QETN1EM-476Z	E CAPACITOR	
	C4303	QETN1HM-225Z	E CAPACITOR	
	C4304	QETN1HM-225Z	E CAPACITOR	

Symbol No.	Part No.	Part Name	Description	Local
	C4305	NDC31HJ-101X	C CAPACITOR	
	C4306	NDC31HJ-101X	C CAPACITOR	
	C4351	NRSA63J-0R0X	MG RESISTOR	
	C4399	NRSA63J-0R0X	MG RESISTOR	
	C4651	NRSA63J-0R0X	MG RESISTOR	
	C8106	NCB31CK-104X	C CAPACITOR	
	C8206	NCB31CK-104X	C CAPACITOR	
	C8305	NCB20JK-155X	C CAPACITOR	
	C8306	NRSA63J-0R0X	MG RESISTOR	
	C8307	NCB31CK-104X	C CAPACITOR	
	C8351	NRSA63J-0R0X	MG RESISTOR	
△	R901	QRZ9037-335	COMP RESISTOR	
△	R903	QRL02DJ-223X	OMF RESISTOR	
	R904	NRSA63J-683X	MG RESISTOR	
	R905	NRSA63J-563X	MG RESISTOR	
	R908	NRSA63J-332X	MG RESISTOR	
	R909	NRSA63J-432X	MG RESISTOR	
	R910	QRE141J-100Y	C RESISTOR	
	R951	NRSA63J-752X	MG RESISTOR	
	R952	NRSA63J-152X	MG RESISTOR	
	R953	NRSA63J-113X	MG RESISTOR	
	R954	NRSA63J-102X	MG RESISTOR	
	R955	NRSA63J-202X	MG RESISTOR	
	R957	NRSA63J-392X	MG RESISTOR	
	R958	NRSA63J-102X	MG RESISTOR	
△	R959	QRZ9005-100X	FUSI RESISTOR	
	R2201	NRSA63J-0R0X	MG RESISTOR	
	R2203	NRSA63J-104X	MG RESISTOR	
	R2206	NRSA63J-103X	MG RESISTOR	
	R2207	NRSA63J-0R0X	MG RESISTOR	
	R2411	NRSA63J-240X	MG RESISTOR	
	R2501	NRSA63J-431X	MG RESISTOR	
	R2502	NRSA63J-511X	MG RESISTOR	
	R2503	NRSA63J-122X	MG RESISTOR	
	R2504	NRSA63J-431X	MG RESISTOR	
	R2505	NRSA63J-511X	MG RESISTOR	
	R4151	NRSA63J-133X	MG RESISTOR	
	R4152	NRSA63J-513X	MG RESISTOR	
	R4251	NRSA63J-133X	MG RESISTOR	
	R4252	NRSA63J-513X	MG RESISTOR	
	R4301	NRSA63J-473X	MG RESISTOR	
	R4302	NRSA63J-473X	MG RESISTOR	
	R4303	NRSA63J-104X	MG RESISTOR	
	R4304	NRSA63J-104X	MG RESISTOR	
	R4305	NRSA63J-102X	MG RESISTOR	
	R4306	NRSA63J-102X	MG RESISTOR	
	R8302	NRSA63J-102X	MG RESISTOR	
△	L901	QQR1799-001	LINE FILTER	
△	L902	QQR1800-001	LINE FILTER	
	L952	QQL50AK-221Z	COIL	
	L954	QQL56AK-220Z	COIL	
△	T901	QQS0404-001	SW TRANSF	
	CN103	or QNZ0926-001	USB CONNECTOR	
	CN103	QNZ0851-001	USB CONNECTOR	
	CN104	QGA2001C1-05	CONNECTOR	
	CN221	QGF1040F1-20	CONNECTOR	
	CN402	QGB1214K1-10S	CONNECTOR	
	CN701	QGF1040F1-23	CONNECTOR	
	CN702	QGB1214K1-20S	CONNECTOR	
	CN901	QGB2510K2-10	CONNECTOR	
△	CP901	ICP-N10-T	IC PROTECTOR	
△	CP901	or QMFZ050-1R5X-E	FUSE	
△	CP902	ICP-N20-T	IC PROTECTOR	
	DI221	QLF0186-001	FL TUBE	
	DI221	or QLF0190-001	FL TUBE	
	FC901	QNG0003-001Z	FUSE CLIP	
	FC902	QNG0003-001Z	FUSE CLIP	
	HS901	GN40147-001A	HEAT SINK	
	J4351	QNS0188-001	JACK	
	J4352	QNS0188-001	JACK	
	J8001	QNS0188-001	JACK	
	JS261	QSW1130-001	ROTARY ENCODER	
	K102	NQR0502-002X	FERRITE BEADS	

Symbol No.	Part No.	Part Name	Description	Local
K103	NQR0502-002X	FERRITE BEADS		
K105	NQR0022-002X	FERRITE BEADS		
K106	NQR0022-002X	FERRITE BEADS		
K4351	NRSA63J-0R0X	MG RESISTOR		
K4602	NRSA63J-0R0X	MG RESISTOR		
K8101	NQR0389-003X	FERRITE BEADS		
K8201	NQR0389-003X	FERRITE BEADS		
K8301	NQR0389-003X	FERRITE BEADS		
P901	QGA7901C1-02	CONNECTOR		
S2501	QSW0825-001Z	TACT SW		
S2502	QSW0825-001Z	TACT SW		
S2503	QSW0825-001Z	TACT SW		
S2504	QSW0825-001Z	TACT SW		
S2505	QSW0825-001Z	TACT SW		
S2506	QSW0825-001Z	TACT SW		
S2507	QSW0825-001Z	TACT SW		
S2509	QSW0825-001Z	TACT SW		
S2510	QSW0825-001Z	TACT SW		
S2511	QSW0825-001Z	TACT SW		
S2512	QSW0825-001Z	TACT SW		
W901	QZW0112-001	WIRE CLAMP		

Symbol No.	Part No.	Part Name	Description	Local
D3701	MTZJ30C-T2	Z DIODE		
D3703	FR104S-T5	FR DIODE		
D3704	1SS133-T2	SI DIODE		
D3705	MTZJ2.4B-T2	Z DIODE		
D3801	MTZJ12B-T2	Z DIODE		
D3802	MTZJ3.3B-T2	Z DIODE		
D3803	1SS133-T2	SI DIODE		
D4501	1SS133-T2	SI DIODE		
D5001	MC2838-X	DIODE		
D5101	MC2838-X	DIODE		
D5301	MC2838-X	DIODE		
D7001	1SS133-T2	SI DIODE		
D7002	MTZJ3.3B-T2	Z DIODE		
D7003	MC2838-X	DIODE		

## Input board

Block No. [0][2]

Symbol No.	Part No.	Part Name	Description	Local
IC303	LC75345M-X	IC		
IC372	RT9164A-PG-X	IC		
IC373	MM1594AF-X	IC		
IC452	NJM4565M-WE	IC		
IC452	or LM358DR-X	IC		
IC501	TPA3100D2PHP-W	IC		
IC701	MN101E16KAC	IC		
IC702	BR24L02F-W-X	IC(DIGITAL)		
IC801	NJM4565M-WE	IC		
Q3401	KTB772/Y/	TRANSISTOR		
Q3402	2SC3928A/QR/-X	TRANSISTOR		
Q3501	KTA1046/Y/	TRANSISTOR		
Q3502	2SC3928A/QR/-X	TRANSISTOR		
Q3601	2SC5938A/B/-X	TRANSISTOR		
Q3602	2SC5938A/B/-X	TRANSISTOR		
Q3701	2SC3576-JVC-T	TRANSISTOR		
Q3702	RT1P441C-X	DIGI TRANSISTOR		
Q3710	KTA1267/YG/T	TRANSISTOR		
Q3801	KTB772/Y/	TRANSISTOR		
Q3802	2SC3928A/QR/-X	TRANSISTOR		
Q3803	RT1P430C-X	TRANSISTOR		
Q3804	RT1N141C-X	DIGI TRANSISTOR		
Q4501	RT1N44HC-X	DIGI TRANSISTOR		
Q4502	2SA1530A/QR/-X	TRANSISTOR		
Q4503	RT1N431C-X	TRANSISTOR		
Q4601	KTC812T-X	IC		
Q4603	RT1P441C-X	DIGI TRANSISTOR		
Q4604	KTC812T-X	IC		
Q4606	RT1P141C-X	DIGI TRANSISTOR		
Q7001	RT1N430C-X	TRANSISTOR		
Q7002	RT1N430C-X	TRANSISTOR		
Q7003	2SA1530A/QR/-X	TRANSISTOR		
Q8102	KTC812T-X	IC		
Q8103	KTC812T-X	IC		
Q8301	RT1P431C-X	IC		
D3305	MC2838-X	DIODE		
D3401	1SS133-T2	SI DIODE		
D3402	MTZJ6.8B-T2	Z DIODE		
D3403	1SS133-T2	SI DIODE		
D3501	MTZJ4.3B-T2	Z DIODE		
D3502	1SS133-T2	SI DIODE		
D3503	1SS133-T2	SI DIODE		
D3504	1N4003S-T5	SI DIODE		
D3506	1N4003S-T5	SI DIODE		
D3507	1N4003S-T5	SI DIODE		

C3140	QFVF1HJ-154Z	MF CAPACITOR		
C3141	QFVF1HJ-154Z	MF CAPACITOR		
C3142	QFVF1HJ-104Z	MF CAPACITOR		
C3143	QFVF1HJ-104Z	MF CAPACITOR		
C3144	QFLC1HJ-272Z	M CAPACITOR		
C3145	QETN1HM-475Z	E CAPACITOR		
C3148	QETN1HM-104Z	E CAPACITOR		
C3149	QTE1J46-106Z	E CAPACITOR		
C3150	QETN1CM-226Z	E CAPACITOR		
C3151	NCB31HK-223X	C CAPACITOR		
C3152	NCB31EK-683X	C CAPACITOR		
C3153	NCB31EK-683X	C CAPACITOR		
C3154	QFVF1HJ-474Z	MF CAPACITOR		
C3155	QETN1HM-475Z	E CAPACITOR		
C3156	QETN1HM-475Z	E CAPACITOR		
C3240	QFVF1HJ-154Z	MF CAPACITOR		
C3241	QFVF1HJ-154Z	MF CAPACITOR		
C3242	QFVF1HJ-104Z	MF CAPACITOR		
C3243	QFVF1HJ-104Z	MF CAPACITOR		
C3244	QFLC1HJ-272Z	M CAPACITOR		
C3245	QETN1HM-475Z	E CAPACITOR		
C3248	QETN1HM-104Z	E CAPACITOR		
C3249	QTE1J46-106Z	E CAPACITOR		
C3250	QETN1CM-226Z	E CAPACITOR		
C3251	NCB31HK-223X	C CAPACITOR		
C3252	NCB31EK-683X	C CAPACITOR		
C3253	NCB31EK-683X	C CAPACITOR		
C3254	QFVF1HJ-474Z	MF CAPACITOR		
C3255	QETN1HM-475Z	E CAPACITOR		
C3256	QETN1HM-475Z	E CAPACITOR		
C3311	QETN1HM-105Z	E CAPACITOR		
C3312	QETN1HM-106Z	E CAPACITOR		
C3341	QETN1AM-227Z	E CAPACITOR		
C3342	QETN1AM-227Z	E CAPACITOR		
C3401	QETN1HM-106Z	E CAPACITOR		
C3402	NCB31HK-103X	C CAPACITOR		
C3404	QETN1CM-107Z	E CAPACITOR		
C3501	QETN1HM-106Z	E CAPACITOR		
C3502	NCB31HK-103X	C CAPACITOR		
C3503	QETN1CM-107Z	E CAPACITOR		
C3511	QETN1CM-477Z	E CAPACITOR		
C3711	NCB31CK-105X	C CAPACITOR		
C3712	QETN1CM-107Z	E CAPACITOR		
C3713	NCB31CK-105X	C CAPACITOR		
C3714	NCB31CK-105X	C CAPACITOR		
C3715	QETN1CM-107Z	E CAPACITOR		
C3716	NCB31HK-471X	C CAPACITOR		
C3717	NCB31CK-105X	C CAPACITOR		
C3723	QETN1CM-107Z	E CAPACITOR		
C3801	QETN0JM-476Z	E CAPACITOR		
C3802	QETN1CM-107Z	E CAPACITOR		
C3803	NCB31HK-103X	C CAPACITOR		
C4501	QETN1HM-106Z	E CAPACITOR		
C4502	QETN1EM-476Z	E CAPACITOR		
C4503	QETN1EM-476Z	E CAPACITOR		
C4510	NCB31CK-224X	C CAPACITOR		
C4601	NDC31HJ-471X	C CAPACITOR		
C4602	NDC31HJ-471X	C CAPACITOR		
C4603	QETN1HM-106Z	E CAPACITOR		
C4607	NDC31HJ-101X	C CAPACITOR		
C4608	NDC31HJ-101X	C CAPACITOR		
C5101	NDC31HJ-331X	C CAPACITOR		
C5102	NCB21AK-225X	C CAPACITOR		

△ Symbol No.	Part No.	Part Name	Description	Local	△ Symbol No.	Part No.	Part Name	Description	Local
C5103	QTE1J46-106Z	E CAPACITOR							
C5104	NCB21CK-105X	C CAPACITOR			R3140	NRSA63J-153X	MG RESISTOR		
C5105	NCB21HK-104X	C CAPACITOR			R3141	NRSA63J-752X	MG RESISTOR		
C5106	NCB21HK-104X	C CAPACITOR			R3142	NRSA63J-473X	MG RESISTOR		
C5107	NCB31HK-223X	C CAPACITOR			R3143	NRSA63J-223X	MG RESISTOR		
C5108	NCB31HK-223X	C CAPACITOR			R3144	NRSA63J-472X	MG RESISTOR		
C5111	NDC31HJ-221X	C CAPACITOR			R3145	NRSA63J-222X	MG RESISTOR		
C5112	NCB31HK-332X	C CAPACITOR			R3146	NRSA63J-182X	MG RESISTOR		
C5113	NDC31HJ-221X	C CAPACITOR			R3147	NRSA63J-622X	MG RESISTOR		
C5114	NDC31HJ-221X	C CAPACITOR			R3148	NRSA63J-224X	MG RESISTOR		
C5115	QETN1HM-106Z	E CAPACITOR			R3149	NRSA63J-683X	MG RESISTOR		
C5116	QETN1HM-106Z	E CAPACITOR			R3150	NRSA63J-153X	MG RESISTOR		
C5117	NCB31AK-334X	C CAPACITOR			R3152	NRSA63J-102X	MG RESISTOR		
C5118	NCB31AK-334X	C CAPACITOR			R3155	NRSA63J-392X	MG RESISTOR		
C5119	NCB31CK-224X	C CAPACITOR			R3158	NRSA63J-0R0X	MG RESISTOR		
C5120	NCB31CK-224X	C CAPACITOR			R3240	NRSA63J-153X	MG RESISTOR		
C5122	NCB31HK-103X	C CAPACITOR			R3241	NRSA63J-752X	MG RESISTOR		
C5123	NCB31HK-103X	C CAPACITOR			R3242	NRSA63J-473X	MG RESISTOR		
C5201	NDC31HJ-331X	C CAPACITOR			R3243	NRSA63J-223X	MG RESISTOR		
C5202	NCB21AK-225X	C CAPACITOR			R3244	NRSA63J-472X	MG RESISTOR		
C5203	QTE1J46-106Z	E CAPACITOR			R3245	NRSA63J-222X	MG RESISTOR		
C5204	NCB21CK-105X	C CAPACITOR			R3246	NRSA63J-182X	MG RESISTOR		
C5205	NCB21HK-104X	C CAPACITOR			R3247	NRSA63J-622X	MG RESISTOR		
C5206	NCB21HK-104X	C CAPACITOR			R3248	NRSA63J-224X	MG RESISTOR		
C5207	NCB31HK-223X	C CAPACITOR			R3249	NRSA63J-683X	MG RESISTOR		
C5208	NCB31HK-223X	C CAPACITOR			R3250	NRSA63J-153X	MG RESISTOR		
C5211	NDC31HJ-221X	C CAPACITOR			R3252	NRSA63J-102X	MG RESISTOR		
C5212	NCB31HK-332X	C CAPACITOR			R3255	NRSA63J-392X	MG RESISTOR		
C5213	NDC31HJ-221X	C CAPACITOR			R3258	NRSA63J-0R0X	MG RESISTOR		
C5214	NDC31HJ-221X	C CAPACITOR			R3308	NRSA63J-224X	MG RESISTOR		
C5215	QETN1HM-106Z	E CAPACITOR			R3309	NRSA63J-124X	MG RESISTOR		
C5216	QETN1HM-106Z	E CAPACITOR			R3310	NRSA63J-223X	MG RESISTOR		
C5217	NCB31AK-334X	C CAPACITOR			R3341	NRSA63J-330X	MG RESISTOR		
C5218	NCB31AK-334X	C CAPACITOR			R3342	NRSA63J-472X	MG RESISTOR		
C5219	NCB31CK-224X	C CAPACITOR			R3343	NRSA63J-472X	MG RESISTOR		
C5220	NCB31CK-224X	C CAPACITOR			R3344	NRSA63J-472X	MG RESISTOR		
C5222	NCB31HK-103X	C CAPACITOR			R3401	QRE141J-471Y	C RESISTOR		
C5223	NCB31HK-103X	C CAPACITOR			R3402	NRSA63J-472X	MG RESISTOR		
C5303	NCB31HK-103X	C CAPACITOR			R3411	NRSA63J-103X	MG RESISTOR		
C5304	NCB21AK-225X	C CAPACITOR			R3412	NRSA63J-222X	MG RESISTOR		
C5305	NCB31CK-105X	C CAPACITOR			R3501	NRSA63J-822X	MG RESISTOR		
C5306	QETN1EM-227Z	E CAPACITOR			R3502	QRE141J-271Y	C RESISTOR		
C5307	NCB31CK-105X	C CAPACITOR			R3503	NRSA63J-473X	MG RESISTOR		
C5308	NCB31CK-105X	C CAPACITOR			R3504	NRSA63J-133X	MG RESISTOR		
C5309	QETN1EM-227Z	E CAPACITOR			R3701	NRSA63J-152X	MG RESISTOR		
C5310	NCB31CK-105X	C CAPACITOR			R3702	NRSA63J-103X	MG RESISTOR		
C5312	QETN1HM-226Z	E CAPACITOR			R3703	NRSA63J-103X	MG RESISTOR		
C7001	QETN1CM-106Z	E CAPACITOR			R3704	QRE141J-5R1Y	C RESISTOR		
C7003	NDC31HJ-151X	C CAPACITOR			R3713	NRSA63F-121X	MG RESISTOR		
C7004	QEZO229-479Z	EDL CAPACITOR			R3714	NRSA63F-301X	MG RESISTOR		
C7005	NCB31CK-104X	C CAPACITOR			R3715	QRE141J-332Y	C RESISTOR		
C7006	QETN1AM-107Z	E CAPACITOR			R3801	NRSA63J-472X	MG RESISTOR		
C7009	NDC31HJ-220X	C CAPACITOR			R3802	NRSA63J-471X	MG RESISTOR		
C7010	NDC31HJ-220X	C CAPACITOR			R3803	QRE141J-821Y	C RESISTOR		
C7012	NCB31CK-104X	C CAPACITOR			R3804	NRSA63J-0R0X	MG RESISTOR		
C7013	NCB31CK-104X	C CAPACITOR			R3807	NRSA63J-0R0X	MG RESISTOR		
C7014	NCB31CK-104X	C CAPACITOR			R4501	NRSA63J-472X	MG RESISTOR		
C7015	NCB31CK-104X	C CAPACITOR			R4502	NRSA63J-472X	MG RESISTOR		
C7016	NCB31CK-473X	C CAPACITOR			R4503	NRSA63J-224X	MG RESISTOR		
C7017	NCB31CK-104X	C CAPACITOR			R4504	NRSA63J-104X	MG RESISTOR		
C7018	NCF31AZ-105X	C CAPACITOR			R4505	NRSA63J-222X	MG RESISTOR		
C8101	QETN1HM-106Z	E CAPACITOR			R4506	NRSA63J-473X	MG RESISTOR		
C8103	NDC31HJ-151X	C CAPACITOR			R4507	NRSA63J-473X	MG RESISTOR		
C8104	NCB31HK-222X	C CAPACITOR			R4512	NRSA63J-272X	MG RESISTOR		
C8105	QETN1AM-227Z	E CAPACITOR			R4513	NRSA63J-103X	MG RESISTOR		
C8107	QETN1HM-475Z	E CAPACITOR			R4514	NRSA63J-102X	MG RESISTOR		
C8201	QETN1HM-106Z	E CAPACITOR			R4601	NRSA63J-102X	MG RESISTOR		
C8203	NDC31HJ-151X	C CAPACITOR			R4602	NRSA63J-102X	MG RESISTOR		
C8204	NCB31HK-222X	C CAPACITOR			R4603	NRSA63J-301X	MG RESISTOR		
C8205	QETN1AM-227Z	E CAPACITOR			R4604	NRSA63J-222X	MG RESISTOR		
C8207	QETN1HM-475Z	E CAPACITOR			R4605	NRSA63J-222X	MG RESISTOR		
C8301	QETN1HM-475Z	E CAPACITOR			R4606	NRSA63J-301X	MG RESISTOR		
C8303	QETN1CM-107Z	E CAPACITOR			R4607	NRSA63J-102X	MG RESISTOR		
C8304	QETN1EM-476Z	E CAPACITOR			R4608	NRSA63J-473X	MG RESISTOR		
C9001	NCF31HZ-103X	C CAPACITOR			R4609	NRSA63J-473X	MG RESISTOR		
C9004	NCB31HK-102X	C CAPACITOR			R4610	NRSA63J-332X	MG RESISTOR		
C9005	QETN1CM-227Z	E CAPACITOR			R4611	NRSA63J-332X	MG RESISTOR		
C9007	NRSA63J-0R0X	MG RESISTOR			R4612	NRSA63J-362X	MG RESISTOR		

△ Symbol No.	Part No.	Part Name	Description	Local	△ Symbol No.	Part No.	Part Name	Description	Local
R4613	NRSA63J-362X	MG RESISTOR			R7067	NRSA63J-222X	MG RESISTOR		
R4614	NRSA63J-472X	MG RESISTOR			R7068	NRSA63J-222X	MG RESISTOR		
R4615	NRSA63J-472X	MG RESISTOR			R7069	NRSA63J-222X	MG RESISTOR		
R5101	NRSA63J-682X	MG RESISTOR			R7070	NRSA63J-222X	MG RESISTOR		
R5102	NRSA63J-473X	MG RESISTOR			R7071	NRSA63J-222X	MG RESISTOR		
R5103	NRSA63J-622X	MG RESISTOR			R7072	NRSA63J-102X	MG RESISTOR		
R5105	NRSA63J-0R0X	MG RESISTOR			R7073	NRSA63J-222X	MG RESISTOR		
R5106	NRSA63J-123X	MG RESISTOR			R7074	NRSA63J-222X	MG RESISTOR		
R5107	NRSA63J-123X	MG RESISTOR			R7075	NRSA63J-222X	MG RESISTOR		
R5108	NRSA63J-152X	MG RESISTOR			R7076	NRSA63J-222X	MG RESISTOR		
R5109	NRSA63J-152X	MG RESISTOR			R7077	NRSA63J-222X	MG RESISTOR		
R5201	NRSA63J-682X	MG RESISTOR			R7080	NRSA63J-104X	MG RESISTOR		
R5202	NRSA63J-473X	MG RESISTOR			R7081	NRSA63J-102X	MG RESISTOR		
R5203	NRSA63J-622X	MG RESISTOR			R7082	NRSA63J-102X	MG RESISTOR		
R5205	NRSA63J-0R0X	MG RESISTOR			R7083	NRSA63J-103X	MG RESISTOR		
R5206	NRSA63J-123X	MG RESISTOR			R7084	NRSA63J-103X	MG RESISTOR		
R5207	NRSA63J-123X	MG RESISTOR			R7085	NRSA63J-332X	MG RESISTOR		
R5208	NRSA63J-152X	MG RESISTOR			R7086	NRSA63J-303X	MG RESISTOR		
R5209	NRSA63J-152X	MG RESISTOR			R7087	NRSA63J-104X	MG RESISTOR		
R5301	NRSA63J-223X	MG RESISTOR			R7088	NRSA63J-104X	MG RESISTOR		
R5304	NRSA63J-103X	MG RESISTOR			R7089	NRSA63J-103X	MG RESISTOR		
R5305	NRSA63J-103X	MG RESISTOR			R7090	NRSA63J-103X	MG RESISTOR		
R5307	NRSA63J-0R0X	MG RESISTOR			R7091	NRSA63J-103X	MG RESISTOR		
R5308	NRSA63J-104X	MG RESISTOR			R7093	NRSA63J-103X	MG RESISTOR		
R5310	NRSA63J-104X	MG RESISTOR			R7094	NRSA63J-103X	MG RESISTOR		
R5311	NRSA63J-104X	MG RESISTOR			R7095	NRSA63J-103X	MG RESISTOR		
R7001	NRSA63J-103X	MG RESISTOR			R7096	NRSA63J-103X	MG RESISTOR		
R7002	NRSA63J-103X	MG RESISTOR			R7097	NRSA63J-103X	MG RESISTOR		
R7004	NRSA63J-104X	MG RESISTOR			R7098	NRSA63J-103X	MG RESISTOR		
R7005	NRSA63J-331X	MG RESISTOR			R7099	NRSA63J-103X	MG RESISTOR		
R7009	NRSA63J-102X	MG RESISTOR			R7100	NRSA63J-472X	MG RESISTOR		
R7010	NRSA63J-102X	MG RESISTOR			R7301	NRSA63J-103X	MG RESISTOR		
R7011	NRSA63J-102X	MG RESISTOR			R7302	NRSA63J-103X	MG RESISTOR		
R7012	NRSA63J-102X	MG RESISTOR			R7303	NRSA63J-222X	MG RESISTOR		
R7013	NRSA63J-222X	MG RESISTOR			R7304	NRSA63J-222X	MG RESISTOR		
R7014	NRSA63J-222X	MG RESISTOR			R8101	NRSA63J-332X	MG RESISTOR		
R7015	NRSA63J-102X	MG RESISTOR			R8104	NRSA63J-332X	MG RESISTOR		
R7016	NRSA63J-102X	MG RESISTOR			R8105	NRSA63J-102X	MG RESISTOR		
R7017	NRSA63J-102X	MG RESISTOR			R8106	NRSA63J-102X	MG RESISTOR		
R7018	NRSA63J-102X	MG RESISTOR			R8107	NRSA63J-220X	MG RESISTOR		
R7019	NRSA63J-102X	MG RESISTOR			R8108	NRSA63J-222X	MG RESISTOR		
R7020	NRSA63J-331X	MG RESISTOR			R8109	NRSA63J-103X	MG RESISTOR		
R7022	NRSA63J-222X	MG RESISTOR			R8110	NRSA63J-102X	MG RESISTOR		
R7028	NRSA63J-0R0X	MG RESISTOR			R8111	NRSA63J-273X	MG RESISTOR		
R7029	NRSA63J-222X	MG RESISTOR			R8112	NRSA63J-332X	MG RESISTOR		
R7030	NRSA63J-0R0X	MG RESISTOR			R8201	NRSA63J-332X	MG RESISTOR		
R7031	NRSA63J-222X	MG RESISTOR			R8204	NRSA63J-332X	MG RESISTOR		
R7032	NRSA63J-0R0X	MG RESISTOR			R8205	NRSA63J-102X	MG RESISTOR		
R7033	NRSA63J-222X	MG RESISTOR			R8206	NRSA63J-102X	MG RESISTOR		
R7034	NRSA63J-331X	MG RESISTOR			R8207	NRSA63J-220X	MG RESISTOR		
R7035	NRSA63J-222X	MG RESISTOR			R8208	NRSA63J-222X	MG RESISTOR		
R7036	NRSA63J-222X	MG RESISTOR			R8209	NRSA63J-912X	MG RESISTOR		
R7037	NRSA63J-222X	MG RESISTOR			R8210	NRSA63J-102X	MG RESISTOR		
R7038	NRSA63J-222X	MG RESISTOR			R8211	NRSA63J-273X	MG RESISTOR		
R7039	NRSA63J-222X	MG RESISTOR			R8212	NRSA63J-332X	MG RESISTOR		
R7040	NRSA63J-222X	MG RESISTOR			R8301	NRSA63J-330X	MG RESISTOR		
R7041	NRSA63J-222X	MG RESISTOR							
R7042	NRSA63J-222X	MG RESISTOR			L3801	QRL01DJ-820X	OMF RESISTOR		
R7043	NRSA63J-331X	MG RESISTOR			L5101	QQLZ037-220	COIL		
R7044	NRSA63J-102X	MG RESISTOR			L5102	QQLZ037-220	COIL		
R7045	NRSA63J-102X	MG RESISTOR			L5103	QQR0797-002	COIL		
R7046	NRSA63J-222X	MG RESISTOR			L5201	QQLZ037-220	COIL		
R7047	NRSA63J-222X	MG RESISTOR			L5202	QQLZ037-220	COIL		
R7048	NRSA63J-102X	MG RESISTOR			L5203	QQR0797-002	COIL		
R7049	NRSA63J-223X	MG RESISTOR			L7001	QQL231K-100Y	COIL		
R7050	NRSA63J-102X	MG RESISTOR			L7003	QQL231K-4R7Y	INDUCTOR		
R7051	NRSA63J-102X	MG RESISTOR			L7004	QQL231K-100Y	COIL		
R7052	NRSA63J-102X	MG RESISTOR							
R7053	NRSA63J-103X	MG RESISTOR			CN373	QGB2510J1-10	CONNECTOR		
R7054	NRSA63J-103X	MG RESISTOR			CN401	QGB1214J1-10S	CONNECTOR		
R7059	NRSA63J-102X	MG RESISTOR			CN432	QGF1016C6-20W	CONNECTOR		
R7060	NRSA63J-102X	MG RESISTOR			CN708	QGA2001C1-05	CONNECTOR		
R7061	NRSA63J-102X	MG RESISTOR			CN709	QGB1214J1-20S	CONNECTOR		
R7062	NRSA63J-102X	MG RESISTOR			CN911	QGF1208C1-15	CONNECTOR		
R7063	NRSA63J-102X	MG RESISTOR			HS351	GV40606-002A	HEAT SINK		
R7064	NRSA63J-101X	MG RESISTOR			J5001	QNB0118-001	SPK TERMINAL		
R7065	NRSA63J-101X	MG RESISTOR			K901	NRSA63J-0R0X	MG RESISTOR		
R7066	NRSA63J-101X	MG RESISTOR			K5101	NQR0413-002X	FERRITE BEADS		

△ Symbol No.	Part No.	Part Name	Description	Local	△ Symbol No.	Part No.	Part Name	Description	Local
K5102	NQR0413-002X	FERRITE BEADS			C631	QEKJ0JM-476Z	E CAPACITOR	47uF 6.3V M	
K5103	NQR0413-002X	FERRITE BEADS			C632	NCF31CZ-224X	C CAPACITOR	0.22uF 16V Z	
K5104	NQR0413-002X	FERRITE BEADS			C633	NCB31HK-102X	C CAPACITOR	1000pF 50V K	
K5201	NQR0413-002X	FERRITE BEADS			C635	NCF31EZ-104X	C CAPACITOR	0.1uF 25V Z	
K5202	NQR0413-002X	FERRITE BEADS			C636	NCB31HK-222X	C CAPACITOR	2200pF 50V K	
K5203	NQR0413-002X	FERRITE BEADS			C637	NCB31HK-222X	C CAPACITOR	2200pF 50V K	
K5204	NQR0413-002X	FERRITE BEADS			C638	NCB31HK-122X	C CAPACITOR	1200pF 50V K	
K7001	NQR0389-003X	FERRITE BEADS			C639	NCB31HK-182X	C CAPACITOR	1800pF 50V K	
W5001	QZW0112-001	WIRE CLAMP			C640	NCB31EK-682X	C CAPACITOR	6800pF 25V K	
X7001	QAX0902-001	CRYSTAL			C641	NCB31HK-222X	C CAPACITOR	2200pF 50V K	
X7001	or QAX0902-002	CRYSTAL			C642	NCB31CK-104X	C CAPACITOR	0.1uF 16V K	
X7001	or QAX0902-003	CRYSTAL			C643	NCB31CK-104X	C CAPACITOR	0.1uF 16V K	
X7001	or QAX0902-004	CRYSTAL			C644	QERF1AM-227Z	E CAPACITOR	220uF 10V M	

## CD servo board

Block No. [0][3]

△ Symbol No.	Part No.	Part Name	Description	Local	△ Symbol No.	Part No.	Part Name	Description	Local
IC101	MN103SFB5KWD3	IC			C651	NCB31CK-473X	C CAPACITOR	0.047uF 16V K	
IC102	MM1565AF-X	IC			C652	NCB31CK-473X	C CAPACITOR	0.047uF 16V K	
IC601	LA6242H-X	IC			C653	NCB31CK-473X	C CAPACITOR	0.047uF 16V K	
IC602	MN6627945EE	IC			C654	NCB31CK-104X	C CAPACITOR	0.1uF 16V K	
IC605	TC74LCX257FTF-X	IC			C655	NCF31EZ-104X	C CAPACITOR	0.1uF 25V Z	
IC721	LB1641	IC			C660	NCF31EZ-104X	C CAPACITOR	0.1uF 25V Z	
Q101	RT1P441C-X	DIGI TRANSISTOR			C661	NCB31HK-103X	C CAPACITOR	0.01uF 50V K	
Q601	2SA1705/ST-T	TRANSISTOR			C662	NCB31CK-104X	C CAPACITOR	0.1uF 16V K	
Q602	2SA1530A/QR-X	TRANSISTOR			C7201	NCB31HK-103X	C CAPACITOR	0.01uF 50V K	
D605	MC2836-X	DIODE			C7202	NCF31EZ-104X	C CAPACITOR	0.1uF 25V Z	
D7201	UDZW4.3B-X	DIODE			C7203	QERF1CM-476Z	E CAPACITOR	47uF 16V M	
C101	NCB31CK-104X	C CAPACITOR	0.1uF 16V K		R101	NRSA63J-103X	MG RESISTOR	10kΩ 1/16W J	
C102	NCB31CK-104X	C CAPACITOR	0.1uF 16V K		R102	NRSA63J-103X	MG RESISTOR	10kΩ 1/16W J	
C103	NCB31CK-104X	C CAPACITOR	0.1uF 16V K		R103	NRSA63J-151X	MG RESISTOR	150Ω 1/16W J	
C104	NCB31CK-104X	C CAPACITOR	0.1uF 16V K		R104	NRSA63J-103X	MG RESISTOR	10kΩ 1/16W J	
C105	QERF1HM-106Z	E CAPACITOR	10uF 50V M		R105	NRSA63J-200X	MG RESISTOR	20Ω 1/16W J	
C106	NCB31CK-104X	C CAPACITOR	0.1uF 16V K		R106	NRSA63J-200X	MG RESISTOR	20Ω 1/16W J	
C107	NCB21AK-225X	C CAPACITOR	2.2uF 10V K		R107	NRSA63J-153X	MG RESISTOR	15kΩ 1/16W J	
C108	NCB31HK-471X	C CAPACITOR	470pF 50V K		R108	NRSA63J-153X	MG RESISTOR	15kΩ 1/16W J	
C109	QERF1AM-227Z	E CAPACITOR	220uF 10V M		R112	NRSA63J-102X	MG RESISTOR	1kΩ 1/16W J	
C110	NCF31AZ-105X	C CAPACITOR	1uF 10V Z		R601	NRSA63J-103X	MG RESISTOR	10kΩ 1/16W J	
C121	NDC31HJ-180X	C CAPACITOR	18pF 50V J		R604	NRSA63J-0R0X	MG RESISTOR	0Ω 1/16W J	
C122	NDC31HJ-180X	C CAPACITOR	18pF 50V J		R605	NRSA63J-0R0X	MG RESISTOR	0Ω 1/16W J	
C602	NCB31HK-561X	C CAPACITOR	560pF 50V K		R606	NRSA63J-333X	MG RESISTOR	33kΩ 1/16W J	
C603	NCB31HK-332X	C CAPACITOR	3300pF 50V K		R607	NRSA63J-473X	MG RESISTOR	47kΩ 1/16W J	
C604	NCB31HK-223X	C CAPACITOR	0.022uF 50V K		R608	NRSA63J-472X	MG RESISTOR	4.7kΩ 1/16W J	
C605	NCB31HK-223X	C CAPACITOR	0.022uF 50V K		R609	NRSA63J-102X	MG RESISTOR	1kΩ 1/16W J	
C606	NDC31HJ-271X	C CAPACITOR	270pF 50V J		R610	NRSA63J-102X	MG RESISTOR	1kΩ 1/16W J	
C607	NCB31HK-822X	C CAPACITOR	8200pF 50V K		R611	NRSA63J-0R0X	MG RESISTOR	0Ω 1/16W J	
C608	NCB31HK-822X	C CAPACITOR	8200pF 50V K		R612	NRS181J-4R7X	MG RESISTOR	4.7Ω 1/8W J	
C609	QEKJ0JM-476Z	E CAPACITOR	47uF 6.3V M		R614	NRSA63J-332X	MG RESISTOR	3.3kΩ 1/16W J	
C610	NCB31AK-334X	C CAPACITOR	0.33uF 10V K		R615	NRSA63J-0R0X	MG RESISTOR	0Ω 1/16W J	
C611	QEKJ0JM-476Z	E CAPACITOR	47uF 6.3V M		R617	NRSA63J-332X	MG RESISTOR	3.3kΩ 1/16W J	
C612	QEKJ0JM-476Z	E CAPACITOR	47uF 6.3V M		R618	NRSA63J-0R0X	MG RESISTOR	0Ω 1/16W J	
C613	NCB31HK-332X	C CAPACITOR	3300pF 50V K		R619	NRSA63J-473X	MG RESISTOR	47kΩ 1/16W J	
C614	NCF31EZ-104X	C CAPACITOR	0.1uF 25V Z		R620	NRSA63J-0R0X	MG RESISTOR	0Ω 1/16W J	
C615	NCB31AK-334X	C CAPACITOR	0.33uF 10V K		R622	NRSA63J-100X	MG RESISTOR	10Ω 1/16W J	
C616	QEKJ0JM-476Z	E CAPACITOR	47uF 6.3V M		R623	NRSA63J-0R0X	MG RESISTOR	0Ω 1/16W J	
C617	NCF31EZ-104X	C CAPACITOR	0.1uF 25V Z		R624	NRSA63J-823X	MG RESISTOR	82kΩ 1/16W J	
C618	NCB31HK-681X	C CAPACITOR	680pF 50V K		R625	NRSA63J-821X	MG RESISTOR	820Ω 1/16W J	
C619	NCB31HK-153X	C CAPACITOR	0.015uF 50V K		R629	NRSA63J-102X	MG RESISTOR	1kΩ 1/16W J	
C620	NCF31EZ-104X	C CAPACITOR	0.1uF 25V Z		R630	NRSA63J-102X	MG RESISTOR	1kΩ 1/16W J	
C621	NCB31HK-102X	C CAPACITOR	1000pF 50V K		R631	NRSA63J-102X	MG RESISTOR	1kΩ 1/16W J	
C622	NCB31CK-823X	C CAPACITOR	0.082uF 16V K		R632	NRSA63J-102X	MG RESISTOR	1kΩ 1/16W J	
C623	NCF31EZ-104X	C CAPACITOR	0.1uF 25V Z		R633	NRSA63J-102X	MG RESISTOR	1kΩ 1/16W J	
C624	QERF1AM-227Z	E CAPACITOR	220uF 10V M		R634	NRSA63J-222X	MG RESISTOR	2.2kΩ 1/16W J	
C625	QEKJ0JM-476Z	E CAPACITOR	47uF 6.3V M		R636	NRSA63J-221X	MG RESISTOR	220Ω 1/16W J	
C626	QEKJ0JM-476Z	E CAPACITOR	47uF 6.3V M		R637	NRSA63J-105X	MG RESISTOR	1MΩ 1/16W J	
C627	NCF31EZ-104X	C CAPACITOR	0.1uF 25V Z		R640	NRSA63J-102X	MG RESISTOR	1kΩ 1/16W J	
C628	NCF31EZ-104X	C CAPACITOR	0.1uF 25V Z		R641	NRSA63J-153X	MG RESISTOR	15kΩ 1/16W J	
C629	NCF31EZ-104X	C CAPACITOR	0.1uF 25V Z		R642	NRSA63J-683X	MG RESISTOR	68kΩ 1/16W J	
C630	QEKJ0JM-476Z	E CAPACITOR	47uF 6.3V M		R643	NRSA63J-562X	MG RESISTOR	5.6kΩ 1/16W J	
					R644	NRSA63J-153X	MG RESISTOR	15kΩ 1/16W J	
					R645	NRSA63J-273X	MG RESISTOR	27kΩ 1/16W J	
					R646	NRSA63J-562X	MG RESISTOR	5.6kΩ 1/16W J	
					R647	NRSA63J-103X	MG RESISTOR	10kΩ 1/16W J	
					R648	NRSA63J-332X	MG RESISTOR	3.3kΩ 1/16W J	
					R649	NRSA63J-562X	MG RESISTOR	5.6kΩ 1/16W J	

Symbol No.	Part No.	Part Name	Description	Local
R650	NRSA63J-153X	MG RESISTOR	15kΩ 1/16W J	
R651	NRSA63J-183X	MG RESISTOR	18kΩ 1/16W J	
R652	NRSA63J-822X	MG RESISTOR	8.2kΩ 1/16W J	
R653	NRSA63J-512X	MG RESISTOR	5.1kΩ 1/16W J	
R654	NRSA63J-472X	MG RESISTOR	4.7kΩ 1/16W J	
R655	NRSA63J-822X	MG RESISTOR	8.2kΩ 1/16W J	
R656	NRSA63J-113X	MG RESISTOR	11kΩ 1/16W J	
R657	NRS181J-220X	MG RESISTOR	22Ω 1/8W J	
R658	NRS181J-220X	MG RESISTOR	22Ω 1/8W J	
R660	NRSA63J-151X	MG RESISTOR	150Ω 1/16W J	
R668	NRSA63J-0R0X	MG RESISTOR	0Ω 1/16W J	
R670	NRSA63J-102X	MG RESISTOR	1kΩ 1/16W J	
R671	NRSA63J-102X	MG RESISTOR	1kΩ 1/16W J	
R672	NRSA63J-0R0X	MG RESISTOR	0Ω 1/16W J	
L101	QLL232K-100Z	COIL	10uH K	
CN101	WJP0093-004A-E	USB CONNECTOR		
CN201	QJK043-050600-E	CONNECTOR		
CN202	QGF0501F8-15X	CONNECTOR	FFC/FPC (1-15)	
CN203	QGF1040F1-23	CONNECTOR	FFC/FPC (1-23)	
CN721	QGF1040F1-05	CONNECTOR	FFC/FPC (1-5)	
S201	QSW1223-001	TACT SW		
X101	QAX0724-001Z	CRYSTAL	12.000000MHz	
X601	QAX0714-001Z	C RESONATOR	16.000MHz	

## CD loading switch board

Block No. [0][4]

Symbol No.	Part No.	Part Name	Description	Local
CN1	QGF1016F9-05	CONNECTOR	FFC/FPC (1-5)	
S1	QSW1074-001	DETECT SWITCH		

**<MEMO>**

# Packing materials and accessories parts list

Block No. M 3 M M

No additional / supplemental order of WARRANTY CARDS are available.

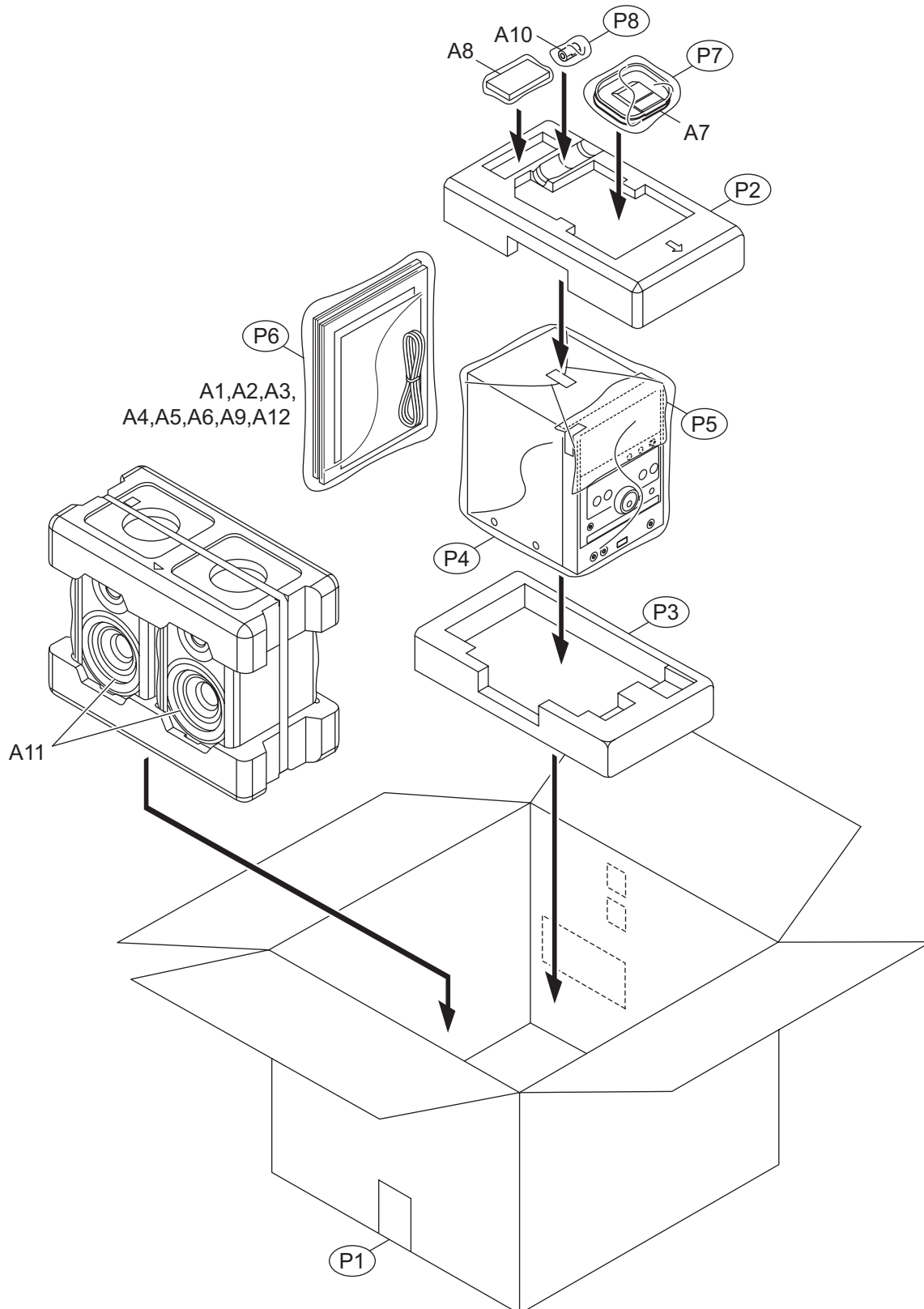

The parts without symbol number are not service.

# Packing and Accessories

Block No. [M][3][M][M]

△ Symbol No.	Part No.	Part Name	Description	Local
A 1	GNT0080-001A	INST BOOK	ENG	G38B,G37B
A 1	GNT0080-002A	INST BOOK	GER	G38E,G39E,G37E
A 1	GNT0080-006A	INST BOOK	SPA	G38EN,G39EN,G37EN
A 1	GNT0080-011A	INST BOOK	RUS	G38EV,G39EV,G37EV
A 2	GNT0080-003A	INST BOOK	FRE	G38E,G39E,G37E
A 2	GNT0080-007A	INST BOOK	POR	G38EN,G39EN,G37EN
A 2	GNT0080-012A	INST BOOK	POL	G38EV,G39EV,G37EV
A 3	GNT0080-004A	INST BOOK	DUT	G38E,G39E,G37E
A 3	GNT0080-008A	INST BOOK	SWE	G38EN,G39EN,G37EN
A 3	GNT0080-013A	INST BOOK	HUN	G38EV,G39EV,G37EV
A 4	GNT0080-005A	INST BOOK	ITA	G38E,G39E,G37E
A 4	GNT0080-009A	INST BOOK	FIN	G38EN,G39EN,G37EN
A 4	GNT0080-014A	INST BOOK	CZE	G38EV,G39EV,G37EV
A 5	GNT0080-010A	INST BOOK	DAN	G38EN,G39EN,G37EN
A 6	QAL0457-001	ANT.WIRE		
A 7	QAL0014-003	AM LOOP ANT		
A 8	RM-SUXG38R	REMCON UNIT		
A 9	-----	WARRANTY CARD	BT-54031-1	
A 10	QQR1607-001	FERRITE CLAMP		
A 11	SPUXG38E-SPBOX	SPEAKER BOX	(x2)	G38B, G38E, G38EN, G38EV, G37B, G37E, G37EN, G37EV
A 11	SPUXG39E-SPBOX	SPEAKER BOX	(x2)	G39E, G39EN, G39EV
A 12	VNA3000-204	REGIST CARD		G38B, G37B
P 1	GV31087-007A	CARTON BOX		G38B, G38E, G38EN, G38EV
P 1	GV31087-009A	CARTON BOX		G39E, G39EN, G39EV
P 1	GV31087-006A	CARTON BOX		G37B, G37E, G37EN, G37EV
P 2	GN10132-002A	CUSHION TOP		
P 3	GN10133-002A	CUSHION BOTTOM		
P 4	QPC05006515PB	POLY BAG		
P 5	GV40437-007A	CLOTH		
P 6	QPC02503515PB	POLY BAG		
P 7	QPA01702503PB	POLY BAG		
P 8	QPA00500805	POLY BAG		