



PRODUCT SPECIFICATION

Version 2.0

IEEE 802.11 b/g/n 1T/1R USB Module

Model Number: W7LM1110 / W7LM1110A

客户认可 Custom Approval Section	
Custom Name	
Department	
Approval	Date:

拟制 DESIGN	审核 CHECK	批准 APPROVAL
朱晓辉	陈宇科	熊运自
2016-11-24	2016-11-24	2016-11-24

制造商:惠州高盛达科技有限公司
Manufacturer: HUIZHOU GAOSHENGDA TECHNOLOGY CO.,LTD

中国惠州仲恺高新技术开发区华宇路 75 号
HUA YU RD., NO.75, ZHONGKAI HIGH-TECH DEVELOPMENT AREA, HUIZHOU, CHINA
TEL: (0752) 2096698 FAX: (0752) 2096628 E-mail: zhuxh@gaosd.cn

Document revision history

Revision	Date	Approved by	Remarks
Version 1.0	2016-09-23		Draft
Version 1.1	2016-09-29		Update: add Schematic diagram add label list & Package add Appendix 4
Version 1.2	2016-09-30		Update: add FCC ID/IC ID
Version 1.3	2016-09-30		Update: Operating Voltage Module label/picture
Version 1.4	2016-10-03		Update: Module picture
Version 1.5	2016-10-11		Update: Appendix 5: Reliability test report Appendix6: Salt spray test report Model test report
Version 1.6	2016-10-14		Update: add Appendix 7: PCB Information
Version 1.7	2016-10-20		Update: Mechanical Dimensions
Version 1.8	2016-10-27		Update: 1.25mm*8PIN SMT connector Part List Add IPEX Connector Module picture
Version 1.9	2016-11-01		Update: Mechanical Dimensions
Version 2.0	2016-11-24		Update: Package

1. General Description

This document is to specify the product requirements for 802.11 b/g/n USB Module. This Module is based on Media Tek MT7601U chipset that complied with IEEE 802.11g, IEEE 802.11b, IEEE 802.11n standard from 2.4G-2.5GHz, and it can be used to provide up to 54Mbps for 802.11g, 11Mbps for 802.11b and 150Mbps for 802.11n to connect your wireless LAN.

With seamless roaming, fully interoperability and advanced security with WEP standard, 802.11b/g/n USB Module offers absolute interoperability with different vendors 802.11 b, 802.11 g, 802.11n Access Points through the wireless LAN.

2. Features

- Compatible with IEEE 802.11b standard to provide wireless 11Mbps data rate.
- Compatible with IEEE 802.11g standard to provide wireless 54Mbps data rate.
- Compatible with IEEE 802.11n standard to provide wireless 150Mbps data rate.
- Operation at 2.4G-2.5GHz frequency band to meet worldwide regulations
- Supports WEP, WPA, WPA2, TKIP, AES enhanced security
- Drivers support Windows XP 32/64, 2000, 7, Vista 32/64, Linux OS
- High speed USB 2.0 interface
- RoHS compliant

3. Application Diagrams

3.1 Functional Block Diagram

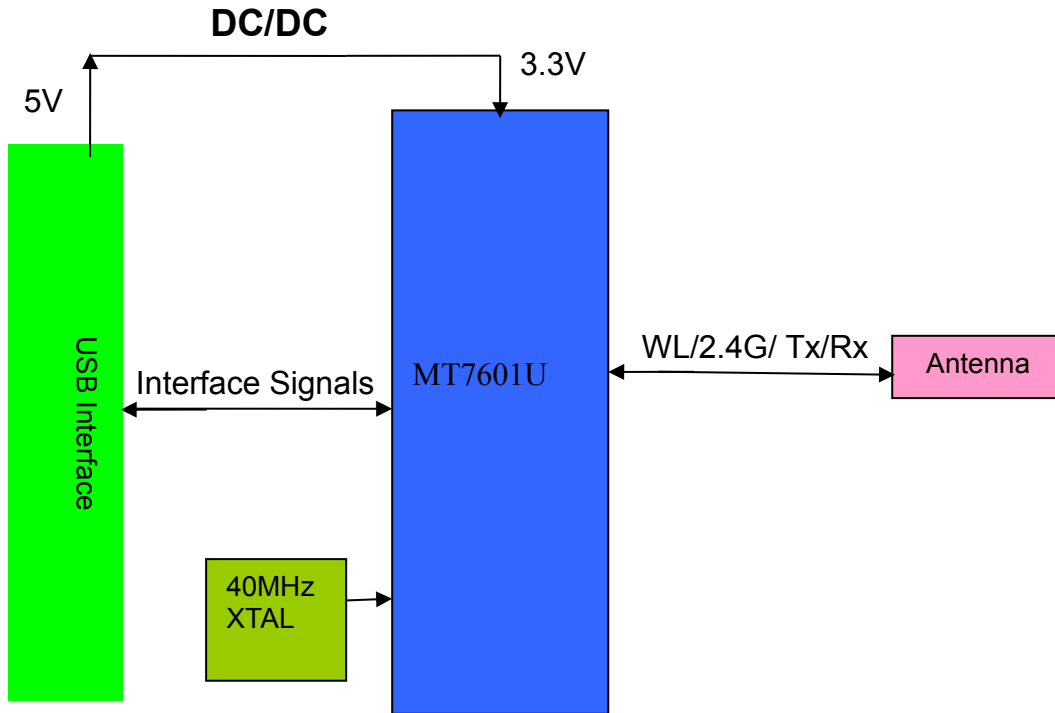

3.2 Schematic diagram

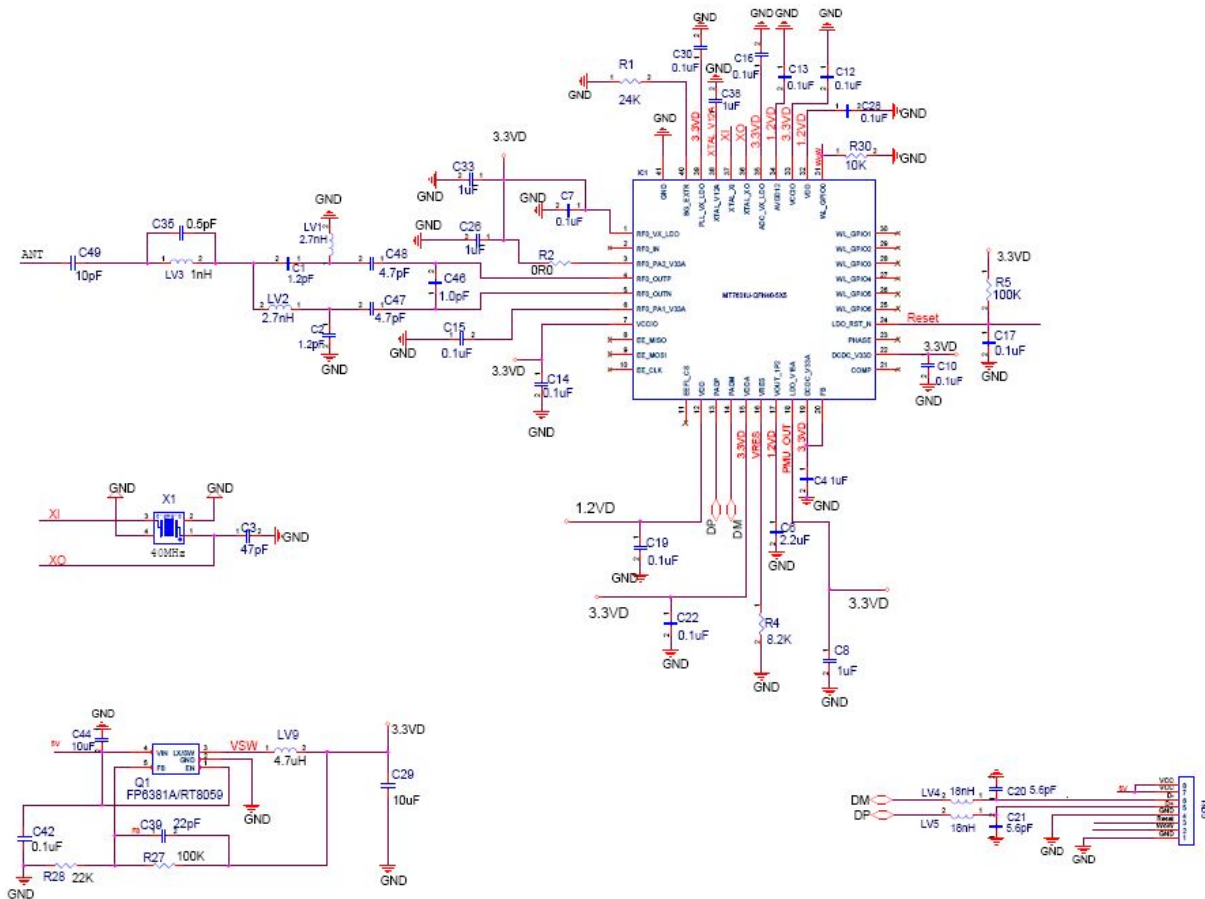

4. General Requirements

4.1 IEEE 802.11b Section

#	Feature	Detailed Description
4.1.1	Standard	<ul style="list-style-type: none"> IEEE 802.11b
4.1.2	Radio and Modulation Schemes	<ul style="list-style-type: none"> DQPSK , DBPSK , DSSS , and CCK
4.1.3	Operating Frequency	<ul style="list-style-type: none"> 2400 ~ 2497MHz ISM band
4.1.4	Channel Numbers	<ul style="list-style-type: none"> 11 channels for United States 13 channels for Europe Countries(Default) 14 channels for Japan
4.1.5	Data Rate	<ul style="list-style-type: none"> 11,5.5,2,and 1Mbps
4.1.6	Media Access Protocol	<ul style="list-style-type: none"> CSMA/CA with ACK
4.1.7	Transmitter Output Power at Antenna Connector	<ul style="list-style-type: none"> Typical RF Output Power at each RF chain,Data Rate and at room Temp. 25degree C 17±1.5dBm at 11Mbps
4.1.8	Receiver Sensitivity at Antenna Connector	<ul style="list-style-type: none"> Typical Sensitivity at Which Frame(1000-byte PDUs)Error Rate=8% at room Temp 25 degree C -90 dBm at 2Mbps -81 dBm for 11Mbps

4.2 IEEE 802.11g Section

#	Feature	Detailed Description
4.2.1	Standard	<ul style="list-style-type: none"> IEEE 802.11g
4.2.2	Radio and Modulation Type	<ul style="list-style-type: none"> QPSK , BPSK , 16QAM ,64QAM with OFDM
4.2.3	Operating Frequency	<ul style="list-style-type: none"> 2400 ~ 2483.5MHz ISM band
4.2.4	Channel Numbers	<ul style="list-style-type: none"> 11 channels for United States 13 channels for Europe Countries(Default) 13 channels for Japan
4.2.5	Data Rate	<ul style="list-style-type: none"> 6,9,12,18,24,36,48,54Mbps
4.2.6	Media Access Protocol	<ul style="list-style-type: none"> CSMA/CA with ACK
4.2.7	Transmitter Output Power at Antenna Connector	<ul style="list-style-type: none"> Typical RF Output Power(tolerance±1.5dBm) at each RF chain, Data Rate and at roomTemp. 25 degree C 14±1.5 dBm at 54Mbps
4.2.8	Receiver Sensitivity at Antenna Connector	<ul style="list-style-type: none"> Typical Sensitivity at each RF chain. Frame(1000-byte PDUs)Error Rate=10% at room Temp 25 degree C -87 dBm at 6Mbps -86 dBm at 9Mbps -84 dBm at 12Mbps -82 dBm at 18Mbps -80 dBm at 24Mbps -76 dBm at 36Mbps -72 dBm at 48Mbps -71 dBm at 54Mbps

4.3 IEEE 802.11n Section

#	Feature	Detailed Description																																																	
4.3.1	Standard	<ul style="list-style-type: none"> IEEE 802.11n 																																																	
4.3.2	Radio and Modulation Type	<ul style="list-style-type: none"> BPSK , QPSK , 16QAM ,64QAM with OFDM 																																																	
4.3.3	Operating Frequency	<ul style="list-style-type: none"> 2400 ~ 2483.5MHz 																																																	
4.3.4	Data Rate(Mbps)	<table border="1" style="width: 100%; border-collapse: collapse;"> <thead> <tr> <th rowspan="2">MCS</th> <th colspan="2">GI=800ns</th> <th colspan="2">GI=400ns</th> </tr> <tr> <th>20MHz</th> <th>40MH</th> <th>20Mz</th> <th>40MHz</th> </tr> </thead> <tbody> <tr> <td>0</td> <td>6.5</td> <td>1.5</td> <td>7.</td> <td>15</td> </tr> <tr> <td>1</td> <td>13</td> <td>27</td> <td>14.4</td> <td>3</td> </tr> <tr> <td>2</td> <td>19.5</td> <td>40.5</td> <td>21.7</td> <td>4</td> </tr> <tr> <td></td> <td>26</td> <td>54</td> <td>28.</td> <td>60</td> </tr> <tr> <td>4</td> <td>39</td> <td>81</td> <td>43.3</td> <td>90</td> </tr> <tr> <td>5</td> <td>52</td> <td>108</td> <td>57.8</td> <td>120</td> </tr> <tr> <td>6</td> <td>58.5</td> <td>121.5</td> <td>65.0</td> <td>135</td> </tr> <tr> <td>7</td> <td>65</td> <td>135</td> <td>72.2</td> <td>150</td> </tr> </tbody> </table>	MCS	GI=800ns		GI=400ns		20MHz	40MH	20Mz	40MHz	0	6.5	1.5	7.	15	1	13	27	14.4	3	2	19.5	40.5	21.7	4		26	54	28.	60	4	39	81	43.3	90	5	52	108	57.8	120	6	58.5	121.5	65.0	135	7	65	135	72.2	150
		MCS		GI=800ns		GI=400ns																																													
			20MHz	40MH	20Mz	40MHz																																													
		0	6.5	1.5	7.	15																																													
		1	13	27	14.4	3																																													
		2	19.5	40.5	21.7	4																																													
			26	54	28.	60																																													
		4	39	81	43.3	90																																													
		5	52	108	57.8	120																																													
6	58.5	121.5	65.0	135																																															
7	65	135	72.2	150																																															
4.3.5	Media Access Protocol	<ul style="list-style-type: none"> CSMA/CA with ACK 																																																	
4.3.6	Transmitter Output Power at Antenna Connector	<ul style="list-style-type: none"> Typical RF Output Power(tolerance±1.5dBm) at each RF chain,Data Rate and at roomTemp. 25degree C HT-20 <ul style="list-style-type: none"> 14±1.5dBm at MCS7 HT-40 <ul style="list-style-type: none"> 14±1.5dBm at MCS7 																																																	
4.3.7	Receiver Sensitivity at Antenna Connector	<ul style="list-style-type: none"> Typical Sensitivity at Which Frame(1000-byte PDUs)Error Rate=10% at roomTemp. 25degree C HT-20 <ul style="list-style-type: none"> -87dBm at MCS0/8 -84dBm at MCS1/9 -82dBm at MCS2/10 -79dBm at MCS3/11 -76dBm at MCS4/12 -72dBm at MCS5/13 -70dBm at MCS6/14 -69dBm at MCS7/15 HT-40 <ul style="list-style-type: none"> -84dBm at MCS0/8 -81dBm at MCS1/9 -80dBm at MCS2/10 -76dBm at MCS3/11 -73dBm at MCS4/12 -69dBm at MCS5/13 -68dBm at MCS6/14 -66dBm at MCS7/15 																																																	

5. Electrical and Thermal Characteristics

5.1 EEPROM Information

Reg Domain	Worldwide Configured by driver
	Offset 0x38 for 5G:0xFF Offset 0x39 for 2.4G:0xFF
Vendor ID	0x148F
Product ID	0x7601

5.2 Temperature Limit Ratings

Parameter	Minimum	Maximum
Storage Temperature	-40°C	+80°C
Storage Relative Humidity	5-90%(non-condensing)	
Operating ambient Temperature	0°C	+80°C
Operating Relative Humidity	5-95%(non-condensing)	

Note: The above temperature is the ambient temperature recommended modules run

5.3 General Section

#	Feature	Detailed Description
5.3.1	Antenna Type	<ul style="list-style-type: none"> PIFA antenna
5.3.2	Operating Voltage	<ul style="list-style-type: none"> 5.0V±5%
5.3.3	Form Factor and Interface	<ul style="list-style-type: none"> High Speed USB2.0 Interface
5.3.4	Connector	<ul style="list-style-type: none"> 1.25-8 pin connector (see appendix)

5.4 Software

Driver	Windows XP 32/64, 2000, 7,Vista 32/64, Linux OS
Security	WEP ,WPA ,WPA2,TKIP,AES

5.5 Power consumption

Power consumption	mode	Average	Max:1A
	TX	240mA	
	RX	200mA	
	Associated Idle mode	160mA	
	unassociated Idle mode	70mA	

Remarks: Strongly recommend TV platform has to fulfill output current at least 1A

5.6 Recommended operation conditions for module

Symbol	Rating	Min	Typ	Max	units
VCC	5V supply	4.75	5	5.25	V

5.7 DC characteristics

Symbol	Parameter	Min	Typ	Max	Units
V_{IL}	Input Low Voltage	-0.28	-	0.6	V
V_{IH}	Input High Voltage	2.0	-	3.63	V
V_{OL}	Output Low Voltage	-0.28	-	0.4	
V_{OH}	Output High Voltage	2.4	-	3.63	V

5.8 WoWLAN

Wake Up System Via WiFi, High Active

5.9 Reset Timing SPEC

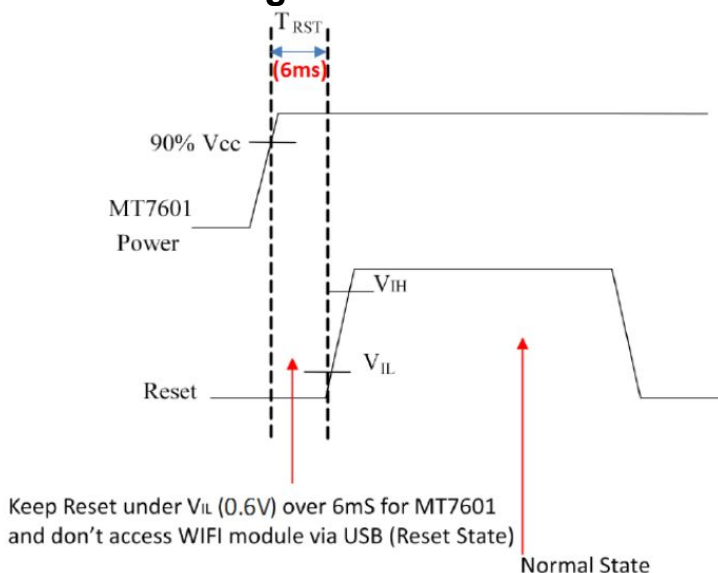

System Reset MT7601u ,Low Active

5.10 Mechanical Dimensions (unit:mm)

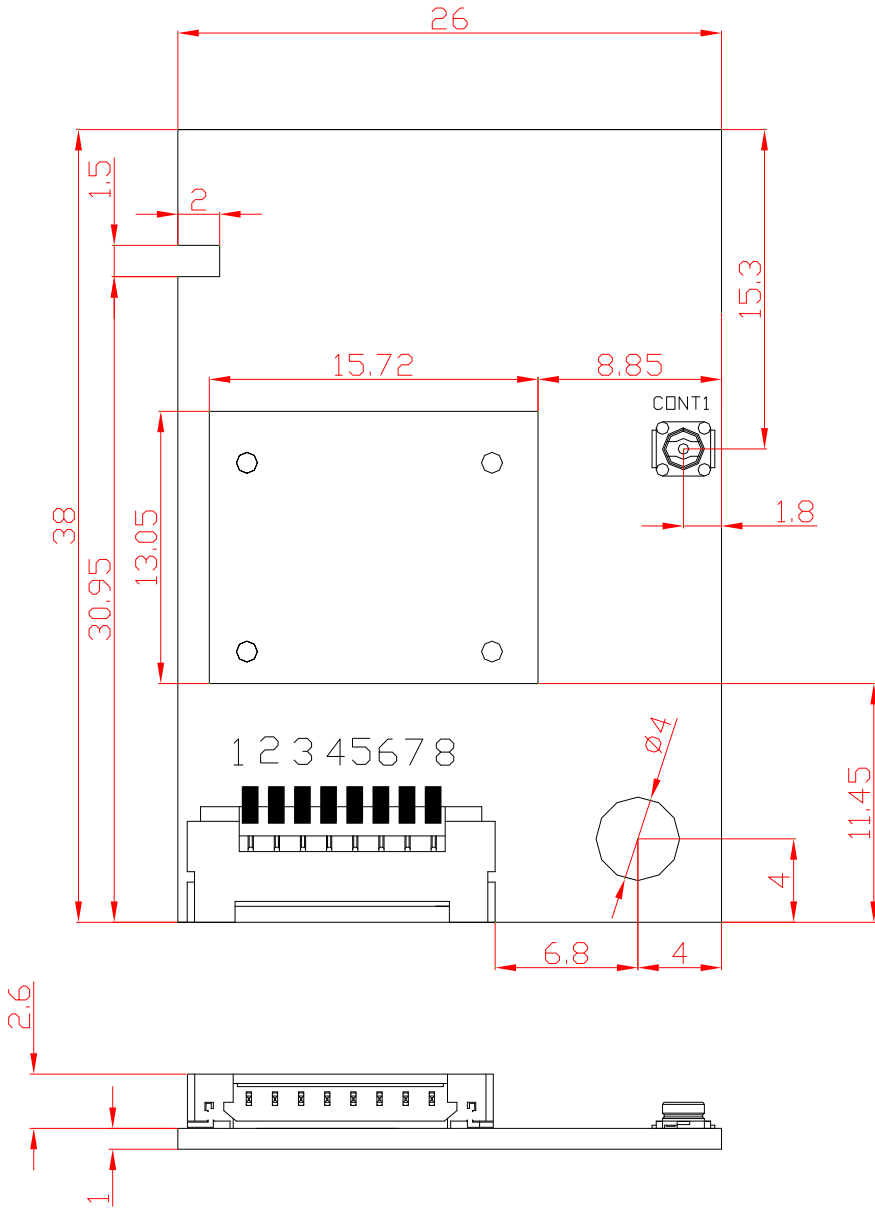

DIM (MM)	Tolerance (MM)
0-5	±0.15
5-10	±0.20
10-50	±0.30

5.11 Pin Description
1.25-8 Pin connector



PRODUCTS SPECIFICATION

W7LM1110

Pin	1	2	3	4	5	6	7	8
Pin Define	GND	WoW	RESET	GND	USB_D+	USB_D-	VCC	VCC
Description	GND	Wake WLAN	RESET	GND	USB Data+	USB Data-	5V	5V

Part List

序号	Type	Specification model	Number	Manufacturer P/N	Manufacturer
1	IC	MT7601U	1	MT7601U	MTK
2		FP6381A		FP6381A	FITI
3	DC-DC	RT8059GJ5/DC/DC converter,1.5MHz,1A,TSOT-23-5	1	RT8059	RICHTEK
4	Capacitance	0201/50V/1pF/±0.1pF/COG	1	GRM0335C1H1R0BA01D	MURATA
5	Capacitance	0201/50V/1.2pF/±0.1pF/COG	2	GRM0335C1H1R2BA01D	MURATA
6	Capacitance	0201/50V/4.7pF/±0.1pF/COG	2	GRM0335C1H4R7BA01D	MURATA
7	Capacitance	0201/50V/5.6pF/±0.25pF/COG	2	GRM0335C1H5R6CA01D	MURATA
8	Capacitance	0201/50V/22pF/±5%/COG	1	GRM0335C1H220JA01D	MURATA
9	Capacitance	0201/50V/47pF/±5%/COG	1	GRM0335C1H470JA01D	MURATA
10	Capacitance	0201/10V/0.1uF/±10%/X5R	13	GRM033R61A104KE15D	MURATA
11	Capacitance	0402/50V/0.5pF/±0.1pF/COG	1	GRM1555C1HR50BA01D	MURATA
12	Capacitance	0402/50V/10pF/±0.5pF/COG	1	GRM1555C1H100JA01D	MURATA
13	Capacitance	0402/10V/1uF/±10%/X5R	5	GRM155R61A105KE15D	MURATA
14	Capacitance	0402/6.3V/2.2uF/±20%/X5R	1	GRM155R60J225ME95D	MURATA
15	Capacitance	0603/6.3V/10uF/±20%/X5R	2	GRM188R60J106ME47D	MURATA
16	Resistance	0201 1/20W 0Ω ±5%	1	WR02X000 PAL / RC0201JR-070R	WALSIN/YAGEO
17	Resistance	0201 1/20W 8.2KΩ ±5%	1	WR02X103 JAL / RC0201JR-078K2	WALSIN/YAGEO
18	Resistance	0201 1/20W 10KΩ ±5%	1	WR02X103 JAL / RC0201JR-0710K	WALSIN/YAGEO
19	Resistance	0201 1/20W 100KΩ ±5%	1	WR02X104 JAL / RC0201JR-07100K	WALSIN/YAGEO
20	Resistance	0402 1/16W 22KΩ ±5%	1	WR04X223 JTL / RC0402JR-0722K	WALSIN/YAGEO
21	Resistance	0402 1/16W 24KΩ ±5%	1	WR04X243 JTL / RC0402JR-0724K	WALSIN/YAGEO
22	Resistance	0402 1/16W 100KΩ ±5%	1	WR04X104 JTL / RC0402JR-07100K	WALSIN/YAGEO
23	Inductance	0201/2.7nH/±0.1nH	2	LQP03TN2N7B02D	MURATA
24	Inductance	0201/18nH/±5%	2	LQP03TN18NJ02D	MURATA
25	Inductance	0402/1.0nH/±0.3nH	1	LQG15HN1N0S02D	MURATA
26	Inductance	0805/4.7uH/±20%/700mA	1	MPB201210T-4R7M-NA2	MURATA
27	Crystal oscillator	40MHz,CL=15pF, 10ppm, LF SMD/3.2X2.5	1	3225/40M	(H.ELE) (CREC)
28		W08-5801-002-00-810		W08-5801-002-00-810	(zhongjun)
29	IPEX	RMVRN-33300-TP00	1	RMVRN-33300-TP00	(youqun)
30	Shield	WF7E	1	WF7E	(RunDa)
31	Connector	1.25/WS/8/A1253WRA-S-08PNLBT1T00R	1	A1253WRA-S-08PNLBT1T00R	(canda)
32	PCB	W7L-2/155*137.6*1.0/20	1	W7L	(FuZhiXiang), (KeXiang)



PRODUCTS SPECIFICATION

W7LM1110

33	label	W7LM1110	1	15*12.5mm/ pet	(ZHONGSHAN FUZHOU ADHESIVE- PRODUCT CO.,LTD)
----	-------	----------	---	-------------------	--

PCB Information

PCB UL Certification



ONLINE CERTIFICATIONS DIRECTORY

ZPMV2.E198407 Wiring, Printed - Component

For enhanced search functionality, please visit UL's iQ™ Family of Databases.
Click on a product designation for complete information.

[Page Bottom](#)

Wiring, Printed - Component

[See General Information for Wiring, Printed - Component](#)

MILLION SOURCES CO LTD HK
ROOM 1401
CAMBRIDGE COMMERCIAL CENTRE
TSIM SHA TSUI, 26-28 CAMERON RD
KOWLOON, HONG KONG

E198407

	Cond Width		Cond	SS/ DSO	Max			Max			Meets	C
	Min	Edge			Area	Solder	Oper	Flame	UL796			
Type	mm(in)	mm(in)	Thk mic(mil)	DSO	mm(in)	C	sec	C	Class	DSR	I	
Mass laminated (multilayered) printed wiring boards.												
MS-M	0.06 (0.002)	0.18 (0.007)	17 (0.67) Int:102	DS	15.5 (0.6)	260	10	130	V-0	All	-	
Multilayer printed wiring boards.												
MS-H1%	0.10 (0.004)	0.10 (0.004)	17 (0.67) Int:170	DS	50.8 (2.0)	288	20	130	V-0	All	*	
MS-M1	0.10 (0.004)	0.20 (0.008)	17 (0.67) Int:102	DS	50.8 (2.0)	288	10	130	V-0	All	*	
Single Layer Metal Base Printed Wiring Board..												
MS-2	0.25 (0.010)	0.25 (0.010)	35 (1.38)	SS	25.4 (1.0)	270	15	125	V-0	-	-	
Single layer printed wiring boards.												
MS-1	0.05 (0.002)	0.15 (0.006)	16.5 (0.65)	DS	15.5 (0.6)	260	10	130	V-0	All	-	
MS-11	0.075 (0.003)	0.10 (0.004)	17 (0.67)	DS	50.8 (2.0)	288	10	130	V-0	All	*	
MS-H%	0.10 (0.004)	0.10 (0.004)	17 (0.67)	DS	50.8 (2.0)	288	20	130	V-0	All	*	

PCB gerber

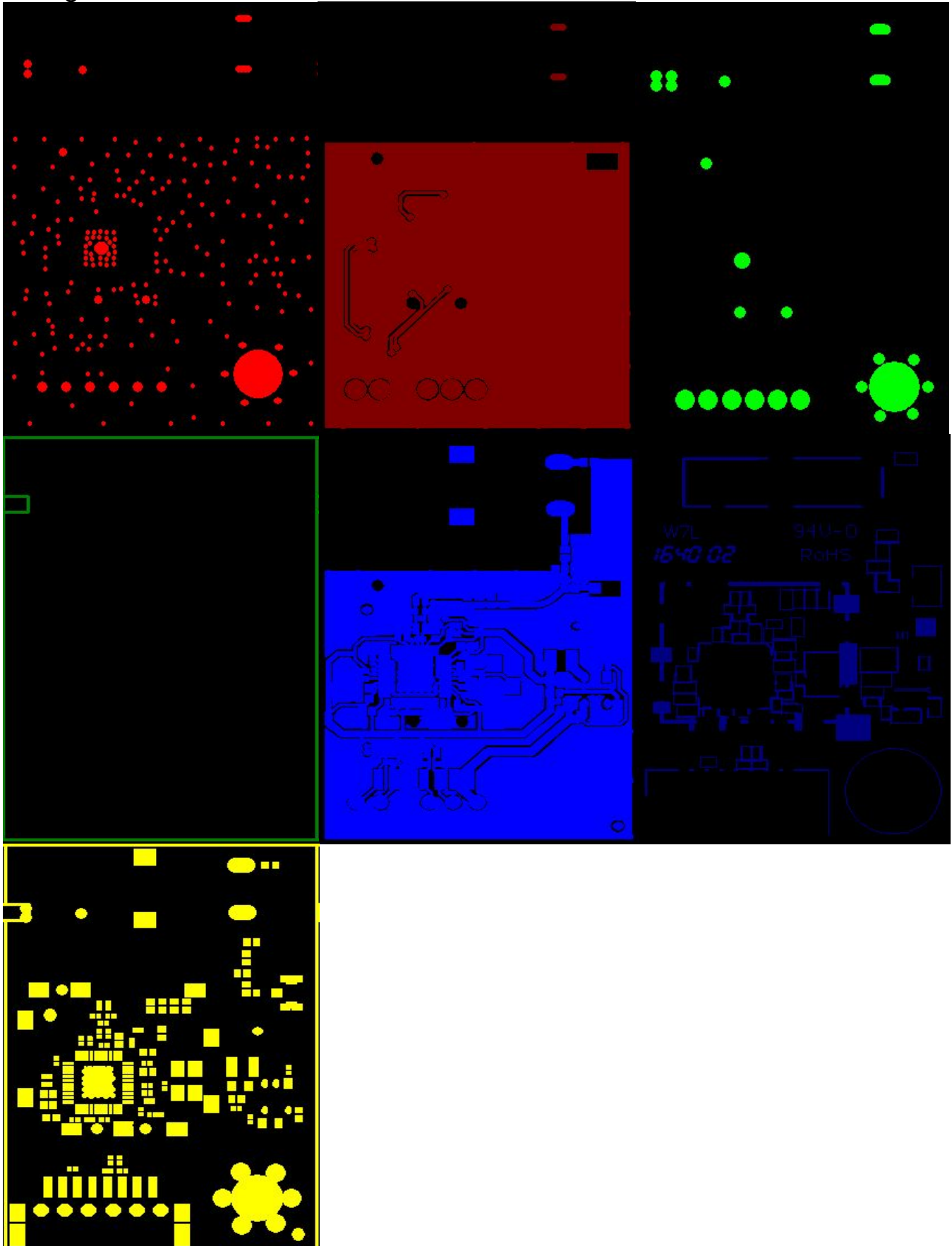

FCC Requirement

changes or modifications not expressly approved by the party responsible for compliance could void the user' s authority to operate the equipment.

This device complies with Part 15 of the FCC Rules. Operation is subject to the following two conditions:

- (1) this device may not cause harmful interference, and
- (2) this device must accept any interference received, including interference that may cause undesired operation.

Note: This equipment has been tested and found to comply with the limits for a Class B digital device, pursuant to Part 15 of the FCC Rules. These limits are designed to provide reasonable protection against harmful interference in a residential installation. This equipment generates, uses, and can radiate radio frequency energy, and if not installed and used in accordance with the instructions, may cause harmful interference to radio communications. However, there is no guarantee that interference will not occur in a particular installation. If this equipment does cause harmful interference to radio or television reception, which can be determined by turning the equipment off and on, the user is encouraged to try to correct the interference by one or more of the following measures:

- Reorient or relocate the receiving antenna.
- Increase the separation between the equipment and receiver.
- Connect the equipment into an outlet on a circuit different from that to which the receiver is connected.
- Consult the dealer or an experienced radio/TV technician for help.

Please notice that if the FCC identification number is not visible when the module is installed inside another device, then the outside of the device into which the module is installed must also display a label referring to the enclosed module. This exterior label can use wording such as the following: "Contains FCC ID: 2AC23-W7LM1110" any similar wording that expresses the same meaning may be used.

IC Requirement

This device complies with Industry Canada license-exempt RSS standard(s). Operation is subject to the following two conditions: (1) this device may not cause interference, and (2) this device must accept any interference, including interference that may cause undesired operation of the device.

Cet appareil est conforme aux CNR exempts de licence d'Industrie Canada. Le fonctionnement est soumis aux deux conditions suivantes:

- (1) Cet dispositif ne peut causer des interférences; et
- (2) Cet appareil doit accepter toute interférence, y compris les interférences qui peuvent causer un mauvais fonctionnement de l'appareil.

Please notice that if the IC identification number is not visible when the module is installed inside another device, then the outside of the device into which the module is installed must also display a label referring to the enclosed module. This exterior label can use wording such as the following: "Contains IC: 12290A-W7LM1110" any similar wording that expresses the same meaning may be used.

L'appareil hôte doit porter une étiquette donnant le numéro de certification du module d'Industrie Canada, précédé des mots « Contient un module d'émission », du mot « Contient » ou d'une formulation similaire exprimant le même sens, comme suit

This equipment should be installed and operated with a minimum distance of 20cm between the radiator and any part of your body.

(1) user manual Information:

The module is limited to OEM installation ONLY

The module is limited to installation in mobile or fixed applications.

The OEM integrator has to be aware not to provide information to the end user regarding how to install or remove this RF module in the user's manual of the end product which integrates this module. The end user manual shall include all required regulatory information/warning as show in this manual.

(2) Co-location Warning:

This device and its antenna(s) must not be co-located or operating in conjunction with any other antenna or transmitter.

(3) OEM integration instructions:

This device is intended only for OEM integrators under the following conditions:

The transmitter module may not be co-located with any other transmitter or antenna.

The module shall be only used with the integral antenna(s) that has been originally tested and certified with this module.

As long as 2 conditions above are met, further transmitter test will not be required. However, the OEM integrator is still responsible for testing their end-product for any additional compliance requirements required with this module installed (for example, digital device emissions, PC peripheral requirements, etc.).

In the event that these conditions cannot be met (for example certain laptop configuration or co-location with another transmitter), then the FCC authorization for this module in combination with the host equipment is no longer considered valid and the FCC ID of the module cannot be used on the final product. In these and circumstance, the OEM integrator will be responsible for re-evaluating. The end product (including the transmitter) and obtaining a separate FCC authorization.