

VS1STS

AC Microdrive

Any trademarks used in this manual are the property of their respective owners.

Important:

Be sure to check www.baldor.com for the latest software, firmware and drivers for your VS1STS product. Also you can download the latest version of this manual in Adobe Acrobat PDF format.

Table of Contents

Chapter 1

Introduction

1.1	Getting Assistance from Baldor	1-1
1.2	Safety Notices	1-1
1.3	Quick Start	1-3

Chapter 2

General Information and Rating

2.1	Identify the Drive by Model Number	2-1
2.2	Storage Guidelines	2-1
2.3	VS1STS Ratings, Model Numbers and Frame Sizes	2-2

Chapter 3

Installing the Drive

3.1	Receiving & Inspection	3-1
3.2	General Requirements for the Installation Site	3-1
3.2.1	Operating Conditions	3-1
3.3	Mounting the Drive	3-2
3.3.1	Enclosure Mounting	3-2
3.3.2	Mounting Clearances	3-3
3.4	Drive Dimensions	3-4

Chapter 4

Power Wiring

4.1	Overview of Power Connections	4-1
4.1.1	Safety Ground	4-1
4.1.2	Motor Ground	4-1
4.1.3	Shield Termination	4-1
4.1.4	RFI Filter Grounding	4-1
4.2	Power Disconnect	4-1
4.3	Protective Devices	4-2
4.4	Electrical Installation	4-2
4.4.1	Branch Circuit Protection	4-2
4.4.2	Single Phase Input Power Connections for 1 Phase Control	4-2
4.4.3	Three Phase Input Power Connections for 3 Phase Control	4-2
4.4.4	Optional Dynamic Brake Hardware Frame B Controls	4-3
4.4.5	Motor Connections	4-3
4.4.6	Long Motor Leads	4-3
4.4.7	M-Contactor Connections	4-3

Chapter 5

Control Wiring

5.1	Control Wiring Overview	5-1
5.2	RJ11 Communication Connection	5-2
5.3	Analog and Digital Input Configurations	5-3
5.3.1	Terminal Strip Mode	5-3
5.3.2	Keypad Mode	5-5
5.3.3	PI Control Mode	5-6
5.3.4	User PI Control Mode	5-7

Chapter 6

Using the Keypad

6.1	Keypad Overview	6-1
6.2	Changing Parameters	6-1
6.3	Reset Factory Default Settings	6-1
6.4	Advanced Keypad Operation Shortcuts	6-2
6.5	Terminal Control	6-3
6.6	Keypad Control	6-3
6.7	Motor Auto Tuning	6-4
6.7.1	AutoTune after Factory Reset or from Factory Set Parameters	6-4
6.7.2	User Selected Auto Tune	6-4
6.8	Operating in Sensorless Vector Speed Control Mode	6-4
6.9	Sensorless Vector Torque Control Mode	6-4

Chapter 7

Parameter Descriptions

7.1	Overview	7-1
7.2	Basic Parameters - Parameter Group 1	7-1
7.3	Extended Parameters	7-3
7.3.1	Parameter Group 2 – Extended Parameters	7-3
7.3.2	Parameter Group 3 – PID Control	7-8
7.3.3	Parameter Group 4 – How Performance Motor Control	7-9
7.3.4	Parameter Group 0 – Monitoring Parameters (Read Only)	7-10
7.4	Advanced Parameters	7-11
7.4.1	Advanced Parameters - Parameter Group 5	7-11
7.4.2	Application Specific Parameters - Parameter Group 6	7-13
7.4.3	Additional Parameter Group 0 – Monitoring Parameters	7-16

Chapter 8

Customizing Your Application

8.1	Simple Parameter Adjustments	8-1
-----	------------------------------	-----

Chapter 9

Troubleshooting

9.1	Fault Codes	9-1
9.2	Periodic Inspection	9-1

Appendix A	
Technical Specifications	A-1
Appendix B	
Parameter Tables	B-1
Appendix C	
CE Guidelines	
C.1 CE Declaration of Conformity	C-1
C.2 EMC - Conformity and CE - Marking	C-1
C.3 EMC Installation Options	C-2
C.4 Grounding for Wall Mounting (Class A) also see Chapters 4 and 5	C-2
C.5 Grounding for Enclosure Mounting (Class B) also see Chapters 4 and 5	C-2
C.6 Using CE approved components will not guarantee a CE compliant system.	C-2
C.7 EMC Wiring Technique	C-3
C.8 EMC Installation Instructions	C-4
Appendix D	
Options & Kits	
D.1 Accessories	D-1
Appendix E	
RS485/MODBUS Protocol	
E.1 Introduction	E-1
E.2 Installation	E-1
E.3 Operation	E-1
E.4 Performance Specifications	E-1
E.5 Hardware Specifications	E-2
E.6 Communication Specifications	E-2
E.7 Communications Protocol (MODBUS-RTU)	E-2
E.8 Modbus Register Map	E-3

Chapter 1

Introduction

This manual is intended for qualified electrical personnel familiar with installing, programming, and maintaining AC Drives. This manual contains information on:

- Installing and wiring the VS1STS drive
- Programming the drive
- Troubleshooting the drive

1.1 Getting Assistance from Baldor

For technical assistance, contact your Baldor District Office. Before calling, please review the troubleshooting section of this manual. You will be asked for the drive model number or catalog number that is located on the Nameplate along with the drive serial number.

1.2 Safety Notices

This equipment contains voltages that may be as high as 1000 volts! Electrical shock can cause serious or fatal injury. Only qualified personnel should attempt the start-up procedure or troubleshoot this equipment.

This equipment may be connected to other machines that have rotating parts or parts that are driven by this equipment. Improper use can cause serious or fatal injury. Only qualified personnel should attempt the start-up procedure or troubleshoot this equipment.

PRECAUTIONS: CLASSIFICATIONS OF CAUTIONARY STATEMENTS

WARNING: Indicates a potentially hazardous situation which, if not avoided, could result in injury or death.

CAUTION: Indicates a potentially hazardous situation which, if not avoided, could result in damage to property.

PRECAUTIONS

WARNING: Do not touch any circuit board, power device or electrical connection before you first ensure that power has been disconnected and there is no high voltage present from this equipment or other equipment to which it is connected. Electrical shock can cause serious or fatal injury. Only qualified personnel should attempt the start-up procedure or troubleshoot this equipment.

WARNING: Be sure that you are completely familiar with the safe operation of this equipment. This equipment may be connected to other machines that have rotating parts or parts that are controlled by this equipment. Improper use can cause serious or fatal injury. Only qualified personnel should attempt the start-up procedure or troubleshoot this equipment.

WARNING: Do not use motor overload relays with and automatic reset feature. These are dangerous since the process may injure someone is a sudden or unexpected automatic restart occurs. If manual reset relays are not available, disable the automatic restart feature using external control wiring.

WARNING: This unit has an automatic restart feature that will start the motor whenever input power is applied and a RUN (FWD or REV) command is issued. If an automatic restart of the motor could cause injury to personnel, the automatic restart feature of the VS1STS should be disabled.

WARNING: Be sure the system is properly grounded before applying power. Do not apply AC power before you ensure that all grounding guidelines have been followed. Electrical shock can cause serious or fatal injury.

WARNING: Do not remove cover for at least five (5) minutes after AC power is disconnected to allow capacitors to discharge. Dangerous voltages are present inside the equipment. Electrical shock can cause serious or fatal injury.

WARNING: Motor circuit may have high voltage present whenever AC power is applied, even when motor is not rotating. Electrical shock can cause serious or fatal injury.

WARNING: Improper operation of control may cause violent motion of the motor shaft and driven equipment. Be certain that unexpected motor shaft movement will not cause injury to personnel or damage to equipment. Certain failure modes of the control can produce peak torque of several times the rated motor torque.

WARNING: Dynamic brake resistors may generate enough heat to ignite combustible materials. Keep all combustible materials and flammable vapors away from brake resistors.

- WARNING:** The motor shaft will rotate during the auto tune procedure. Be certain that the unexpected motor shaft movement will not cause injury to personnel or damage to equipment.
- WARNING:** **MEDICAL DEVICE/PACEMAKER DANGER** - Magnetic and electromagnetic fields in the vicinity of current carrying conductors and industrial motors can result in a serious health hazard to persons with cardiac pacemakers, internal cardiac defibrillators, neurostimulators, metal implants, cochlear implants, hearing aids, and other medical devices. To avoid risk, stay away from the area surrounding a motor and its current carrying conductors.
- CAUTION:** Disconnect motor leads (U, V and W) from control before you perform a “Dielectric Withstand” test on the motor. Failure to disconnect motor from the control will result in extensive damage to the control. The control is tested at the factory for high voltage / leakage resistance as part of Underwriter Laboratory requirements.
- CAUTION:** Suitable for use on a circuit capable of delivering not more than the RMS symmetrical short circuit amperes listed here at rated voltage.
- | Horsepower | RMS Symmetrical Amperes |
|------------|-------------------------|
| 1 – 60 | 5,000 |
- CAUTION:** Do not connect AC power to the Motor terminals U, V and W. Connecting AC power to these terminals may result in damage to the control.
- CAUTION:** Baldor recommends not using “Grounded Leg Delta” transformer power leads that may create ground loops. Instead, we recommend using a four wire Wye.
- CAUTION:** If the DB hardware mounting is any position other than vertical, the DB hardware must be derated by 35% of its rated capacity.
- CAUTION:** Only Baldor cables should be used to connect the keypad and control. These are special twisted pair cables to protect the control and the keypad. Damage associated with other cable types are not covered by the Baldor warranty.
- CAUTION:** If an M-Contractor is installed, the control must be disabled for at least 200msec before the M-Contractor is opened. If the M-Contractor is opened while the control is supplying voltage and current to the motor, the control may be damaged. Before the control is enabled, the M-Contractor must be closed for at least 200msec.
- CAUTION:** Use of power correction capacitors on the output of the drive can result in erratic operation of the motor, nuisance tripping, and/or permanent damage to the drive. Remove power correction capacitors before proceeding. Failure to observe this precaution could result in damage to, or destruction of, the equipment.
- CAUTION:** Integral solid state short circuit protection does not provide branch circuit protection. Branch circuit protection must be provided in accordance with the National Electric Code and any additional local codes.
- CAUTION:** If the DB hardware mounting is any position other than vertical, the DB hardware must be derated by 35% of its rated capacity.
- CAUTION:** Only Baldor cables should be used to connect the keypad and control. These are special twisted pair cables to protect the control and the keypad. Damage associated with other cable types are not covered by the Baldor warranty.
- CAUTION:** If an M-Contactor is installed, the control must be disabled for at least 200msec before the M-Contactor is opened. If the M-Contactor is opened while the control is supplying voltage and current to the motor, the control may be damaged. Before the control is enabled, the M-Contactor must be closed for at least 200msec.
- CAUTION:** Use of power correction capacitors on the output of the drive can result in erratic operation of the motor, nuisance tripping, and/or permanent damage to the drive. Remove power correction capacitors before proceeding. Failure to observe this precaution could result in damage to, or destruction of, the equipment.
- CAUTION:** Integral solid state short circuit protection does not provide branch circuit protection. Branch circuit protection must be provided in accordance with the National Electric Code and any additional local codes.

1.3 Quick Start

Figure 1-1 Power & Motor Terminal Locations

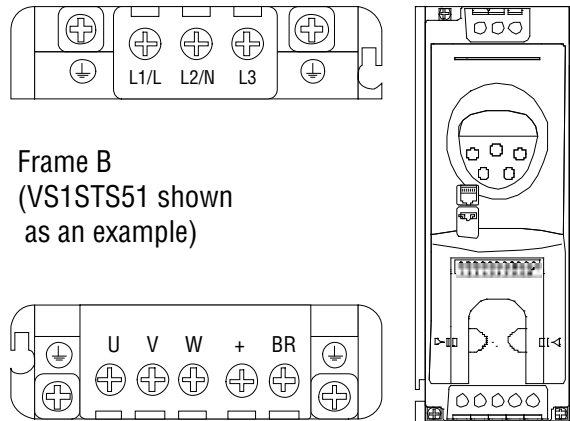

See Recommended Tightening
Torques in Table 4-1.

Power Up Procedure (Refer to Chapter 3, 4 and 5 for additional details.)

1. Remove all power from the control.
2. Couple the motor to its load.
3. Verify freedom of motion of motor shaft.
4. Verify the motor coupling is tight without backlash.
5. Connect input control wires and output control wires, See Figure 1-2.
6. Connect a control switch between terminals 1 and 2 ensuring that the contact is open (drive disabled).
7. Connect Power & Motor wires to the control, See Figure 1-1.
8. Turn power on. Be sure there are no faults.
9. Set the following parameters for the values displayed on the motor nameplate:
 - P1-01 Motor Rated Voltage
 - P1-02 Motor Rated Current
 - P1-03 Motor Rated Frequency
 - P1-04 Motor Rated Speed
10. Set P1-07 Start/Stop Source to 1 or 2
11. Verify the holding brakes if any, are properly adjusted to fully release and set to the desired torque.
12. Enable the drive by closing the switch between control terminals 1 & 2.
13. Press the START key. If this is the first enable from factory default parameters, the drive will carry out an Auto tune as described in Section 6.7. On completion of the Auto tune, the display shows $H \square \square$.
14. Select and program additional parameters to suit your application, see Chapter 7.

The control is now ready for use in the keypad mode. If a different operating mode is desired, refer to Chapter 7 Parameter Descriptions.

Figure 1-2 Input Connections

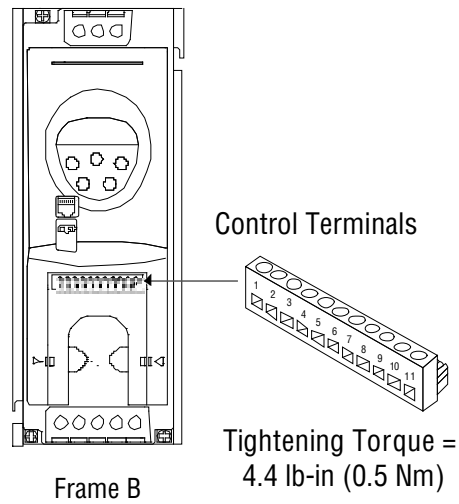

Table 1-1 Control Terminal Descriptions

Terminal	Signal Description
1	+24VDC @ 100mA
2	Digital Input 1 (8-30VDC)
3	Digital Input 2 (8-30VDC) / Digital Output 3 (24V, 10mA max.)
4	Digital Input 3 (8-30VDC) / Analog Input 2 (0-10VDC, 0-20mA or 4-20mA)
5	+24VDC @ 100mA Reference for Potentiometer (1kohm minimum)
6	Analog Input 1 (0-10VDC, 0-20mA or 4-20mA) / Digital Input 4 (8-30VDC)
7	Common (terminals 7 & 9 are connected)
8	Analog Output (0-10VDC @ 20mA max.) / Digital Output (0-24VDC @ 20mA max.)
9	Common (terminals 7 & 9 are connected)
10	Relay Common
11	Relay N.O. Contact (rated 250VAC@6A; 30VDC@5A)

General Information and Ratings

The VS1STS is an adjustable frequency PWM drive operating in V/Hz (volts per hertz) mode. This chapter contains information about the VS1STS drive, including how to identify the drive.

2.1 Identify the Drive by Model Number

Each drive can be identified by its model number, as shown in Figure 2-1. The model number is one the shipping label and the drive nameplate. The model number includes the drive and any options.

Figure 2-1 Drive Identification

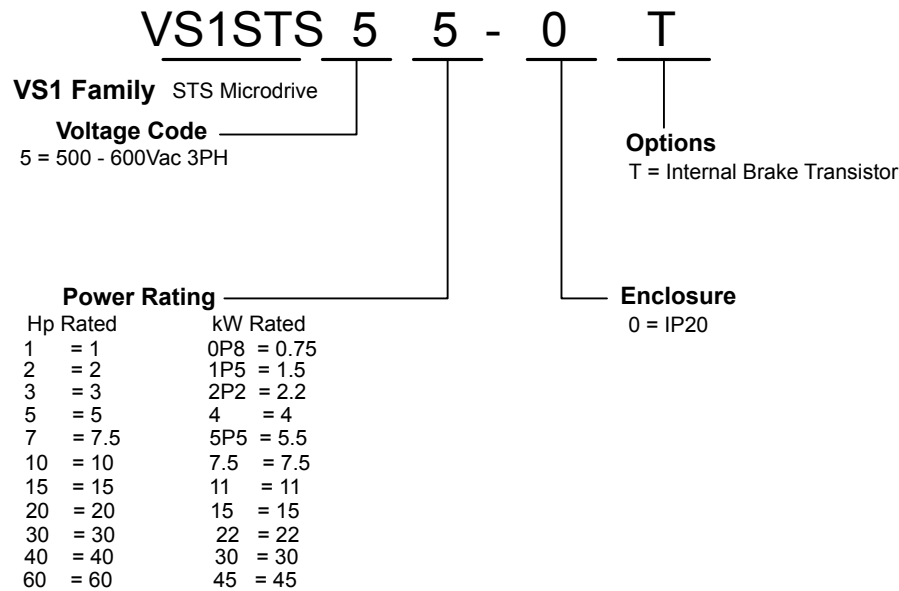

2.2 Storage Guidelines

Follow these recommendations to prolong drive life and performance if storing the drive:

1. Storage surrounding temperature is -40°C to 60°C.
2. Storage Humidity range 10% to 95% RH non-condensing.
3. Do not expose to corrosive atmosphere.

2.3 VS1STS Ratings, Model Numbers and Frame Sizes

Table 2-1 Drive Ratings

HP Model Number	HP	kW	Current (Amps)	
			Input	Output
500-600V +/-10% 3-Phase Input				
VS1STS51	1	0.75	2.2	1.7
VS1STS52	2	1.5	4.1	3.1
VS1STS53	3	2.2	5.4	4.1
VS1STS55	5	4	7.6	6.1
VS1STS57	7.5	5.5	11.7	9
VS1STS510	10	7.5	16.1	14
VS1STS515	15	11	17.3	18
VS1STS520	20	15	24.1	24
VS1STS530	30	22	46.6	39
VS1STS540	40	30	54.1	46
VS1STS560	60	45	69.6	62

Chapter 3

Installing the Drive

This chapter provides information that must be considered when planning a VS1STS drive installation and provides drive mounting information and installation site requirements.

3.1 Receiving & Inspection

When you receive your control, there are several things you should do immediately.

1. Observe the condition of the shipping container and report any damage immediately to the commercial carrier that delivered your control.
2. Remove the control from the shipping container and remove all packing materials from the control. The container and packing materials may be retained for future shipment.
3. Verify that the part number of the control you received is the same as the part number listed on your purchase order.
4. Inspect the control for external physical damage that may have been sustained during shipment and report any damage immediately to the commercial carrier that delivered your control.
5. If the control is to be stored for several weeks before use, make sure that it is stored in a location that conforms to published storage humidity and temperature specifications stated in this manual.

3.2 General Requirements for the Installation Site

It is important to ensure that the drive's environment and operating conditions are satisfactory. The area behind the drive must be kept clear of all control and power wiring. Power connections may create electromagnetic fields that may interfere with control wiring or components when run in close proximity to the drive. Read the recommendations in the following sections before continuing with the drive installation.

3.2.1 Operating Conditions

Before deciding on an installation site, consider the following guidelines:

- Operating surrounding temperature must be within 32°F (0°C) to 104°F (40°C).
If surrounding temperature exceeds 40°C, de-rate the output by 5% per °C above 40°C up to 55°C maximum surrounding temperature.
- Protect the cooling fan by avoiding dust or metallic particles.
- Do not expose the drive to a corrosive atmosphere.
- Protect the drive from moisture and direct sunlight.
- Verify that the drive location will meet the environmental conditions.

3.3 Mounting the Drive

For applications that require a higher IP rating than the IP20 offered by the standard drive, mount in an enclosure following the guidelines below.

- Mount the drive upright on a flat, vertical, level surface.
- Use Figure 3-4 for mounting hole locations.
- Any enclosure should be made from a thermally conductive material.
- When vented enclosures are used, there should be venting above the drive and below the drive to ensure good air circulation. Air should be drawn in below the drive and expelled above the drive.
- If the external environment contains contamination particles such as dust, a suitable particle filter should be fitted to the vents and forced ventilation implemented. The filter must be serviced / cleaned appropriately.
- High moisture, salt or chemical content environments should use a suitable sealed (non-ventilated) enclosure.

3.3.1 Enclosure Mounting

The enclosure design and layout should ensure that adequate ventilation paths and clearances are left to allow air to circulate. The following recommended cabinet sizes are provided for mounting in non-ventilated metallic enclosures.

Figure 3-1 Enclosure Mounting

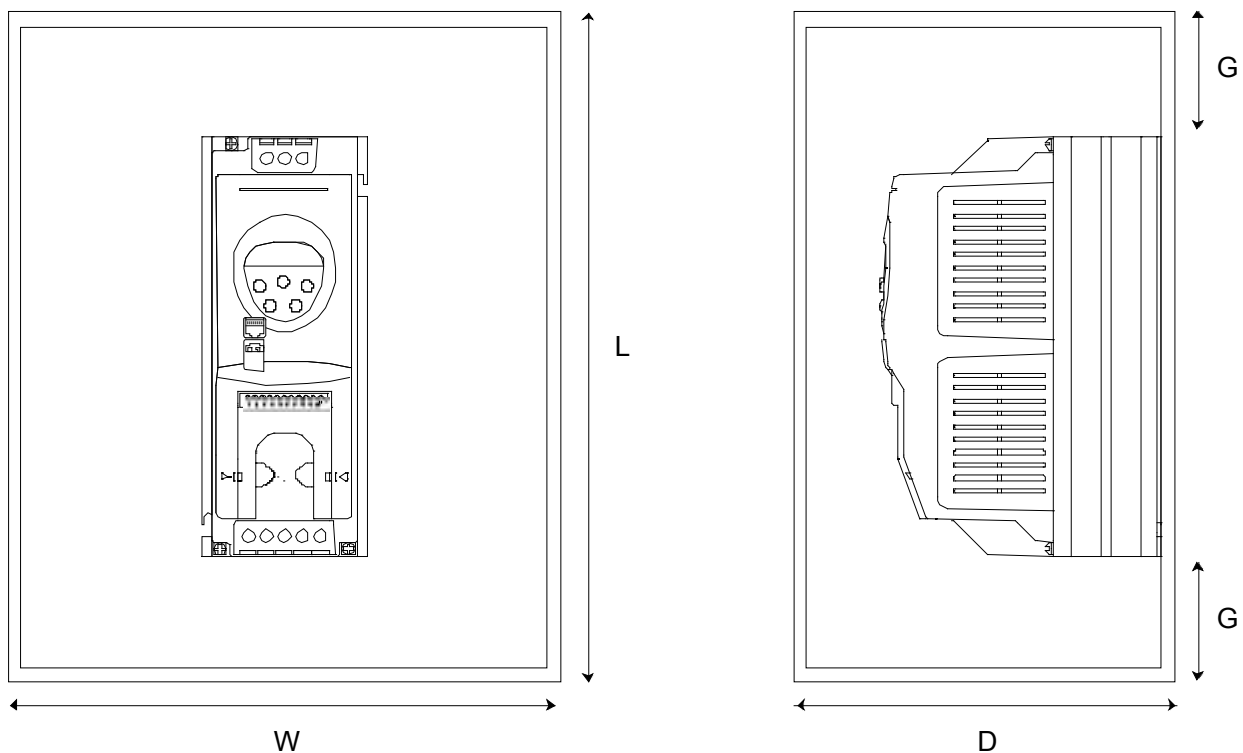

Table 3-1 Non-Ventilated Enclosure Mounting

Drive Rating		H		W		D		G	
		inch	mm	inch	mm	inch	mm	inch	mm
Frame B	2 Hp	15.8	400	11.8	300	11.8	300	2.4	60
Frame B	3 Hp	23.6	600	17.7	450	11.8	300	3.9	100

3.3.2 Mounting Clearances

For drives mounted in ventilated enclosures or force ventilated, the following cabinet sizes are recommended.

Table 3-2 Free-Ventilated Enclosure Mounting

Drive Rating		L		W		D		G	
		inch	mm	inch	mm	inch	mm	inch	mm
Frame B	5 Hp	23.62	600	15.75	400	9.84	250	3.94	100
Frame C	20 Hp	31.50	800	23.62	600	11.81	300	5.91	150
Frame D	30 Hp	39.37	1000	23.62	600	11.81	300	7.87	200

Table 3-3 Force Ventilated Enclosure Mounting

Drive Rating		L		W		D		G	
		inch	mm	inch	mm	inch	mm	inch	mm
Frame B	5 Hp	12.60	320	7.87	200	7.87	200	2.95	75
Frame C	20 Hp	15.75	400	9.84	250	7.87	200	3.94	100
Frame D	30 - 60 Hp	31.50	800	19.69	500	9.84	250	5.12	130

3.4 Drive Dimensions

Figure 3-2 IP20 Mounting Hole Locations

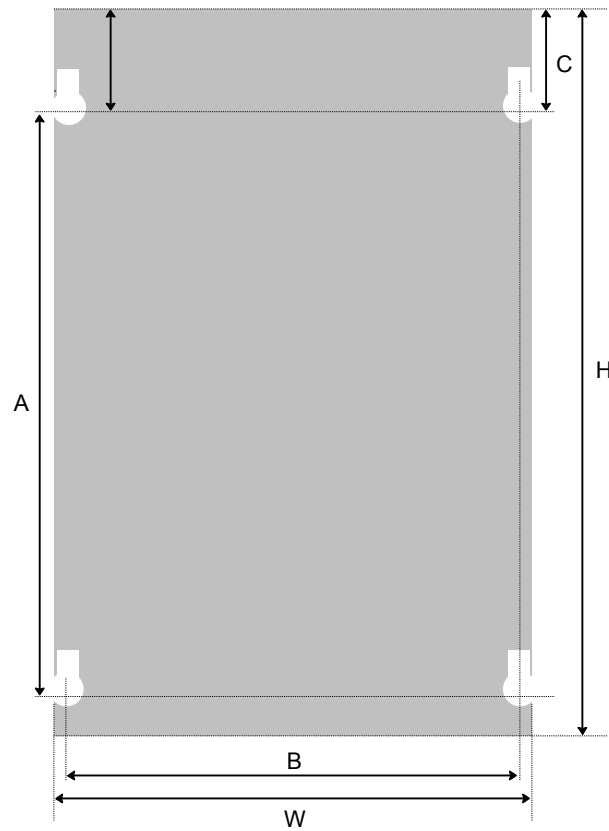

Table 3-4 IP20 Dimensions

Frame	Height		Width		Depth		A		B		C		Weight	
	in	mm	in	mm	in	mm	in	mm	in	mm	in	mm	lb	kg
B	10.24	260	3.94	100	6.89	175	8.27	210	3.62	92	0.98	25	5.73	2.6
C	10.24	260	6.73	171	6.89	175	8.27	210	6.42	163	0.98	25	7.28	5.3
D	20.47	520	13.39	340	8.66	220	16.54	420	12.6	320	1.97	50	61.73	28

Control Terminal Torque Settings of 4.5 lb-in (0.5 Nm)
 Power Terminal Torque Settings of 9 lb-in (1 Nm)

Chapter 4

Power Wiring

4.1 Overview of Power Connections

The recommended grounding method is shown in Figure 4-1.

4.1.1 Safety Ground - (G)

This is the safety ground for the drive that is required by code. One of these points must be connected to adjacent building steel (girder, joist), a floor ground rod, or bus bar. Grounding points must comply with national and local industrial safety regulations and/or electrical codes.

Figure 4-1 Recommended System Grounding

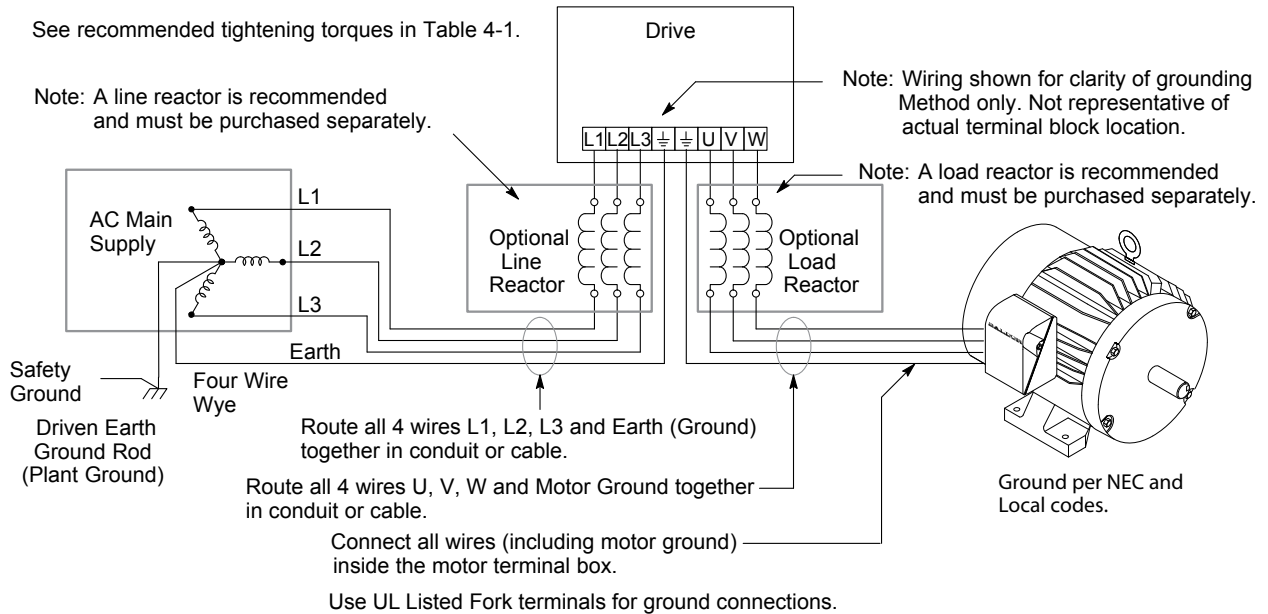

4.1.2 Motor Ground

The motor ground must be connected to one of the ground terminals on the drive. Use UL Listed Fork terminals for ground connections.

4.1.3 Shield Termination

Either of the safety ground terminals located on the power terminal block provides a grounding point for the motor cable shield. The motor cable shield connected to one of these terminals (drive end) should also be connected to the motor frame (motor end). Use a shield terminating or EMI clamp to connect the shield to the safety ground terminal. When shielded cable is used for control and signal wiring, the shield should be grounded at the drive end only, never at both ends.

4.1.4 RFI Filter Grounding

Using single-phase drives with integral filter, or an external filter with any drive rating, may result in relatively high ground leakage currents. Therefore, the filter must only be used in installations with grounded AC supply systems and be permanently installed and solidly grounded (bonded) to the building power distribution ground.

Ensure that the incoming supply neutral is solidly connected (bonded) to the same building power distribution ground. Grounding must not rely on flexible cables and should not include any form of plug or socket that would permit inadvertent disconnection. Some local codes may require redundant ground connections. The integrity of all connections should be checked periodically.

4.2 Power Disconnect

A power disconnect should be installed between the input power service and the drive for a fail safe method to disconnect power. The drive will remain in a powered-up condition until all input power is removed from the drive and the internal bus voltage is depleted.

4.3 Protective Devices

Recommended fuse sizes are based on the following:
115% of maximum continuous current for time delay.
150% of maximum continuous current for Fast or Very Fast action.

Note: These recommendations do not consider harmonic currents or surrounding temperatures greater than 45°C. Be sure a suitable input power protection device is installed. Use the recommended fuses and wire sizes shown in Table 4-1 is based on the use of copper conductor wire rated at 75°C. The table is specified for NEMA B motors.

Fast Action Fuses: 240VAC, Buss® KTN; 460VAC, Buss® KTS
Very Fast Action: 240VAC, Buss® JJN; 460VAC, Buss® JJS
Semiconductor: 240VAC, Ferraz Shawmut A50QS

Buss® is a trademark of Cooper Industries, Inc.

4.4 Electrical Installation

All interconnection wires between the drive, AC power source, motor, host control and any operator interface stations should be in metal conduits or shielded cable must be used. Use UL Listed Fork connectors that are of appropriate size for wire gauge being used. Connectors are to be installed using crimp tool specified by the manufacturer of the connector. Only Class 1 wiring should be used.

4.4.1 Branch Circuit Protection

These devices require branch circuit protection. Branch circuit protection shall be provided. The size of the Branch Circuit Protection Fuse shall be as shown in the ratings table or equivalent.

4.4.2 Single Phase Input Power Connections for 1 Phase Control

All cables must be shielded and the shields must be grounded at the enclosure cable entrance.

1. Connect the single phase input power wires to an appropriate interrupter and protection.
2. Connect the single phase AC input power leads to terminals L1/L and L2/N of the control (see Figure 4-2 for location).
3. Connect the power ground wire to the ground terminal. (See Figure 4-2.)

4.4.3 Three Phase Input Power Connections for 3 Phase Control

All cables must be shielded and the shields must be grounded at the enclosure cable entrance.

1. Connect the three phase input power wires to an appropriate interrupter and protection.
2. Connect the three phase AC input power leads to terminals L1/L, L2/N and L3 of the control (see Figure 4-2 for location).
3. Connect the power ground wire to the ground terminal (see Figure 4-2).

Figure 4-2 Wiring Locations

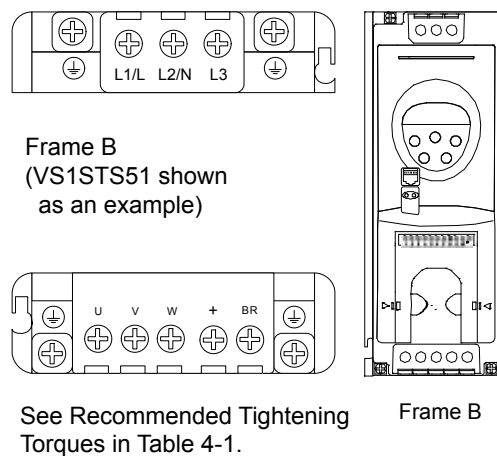

4.4.4 Optional Dynamic Brake Hardware Frame B Controls

If optional DB resistor is to be used, connect it to the + and BR terminals, see (see Figure 4-2). Dynamic Brake (DB) Hardware must be installed on a flat, non-flammable, vertical surface for effective cooling and operation. The DB Resistors get extremely hot during normal operation and must be mounted away from flammable surfaces and unsafe atmosphere.

4.4.5 Motor Connections

All cables must be shielded and the shields must be grounded at the enclosure cable entrance.

1. Connect the Motor leads to terminals U, V and W (see Figure 4-2 for location).
2. Connect the motor ground wire to the ground terminal (See Figure 4-2).

4.4.6 Long Motor Leads

The wire leads that connect the motor to the control are critical in terms of sizing, shielding and the cable characteristics. Short cable runs are usually trouble free but fault-monitoring circuitry can produce numerous faults when long cables are used. Refer to Table 4-1 for maximum cable lengths. Baldor recommends adding an optional load reactor to the output of the control. The load reactor and/or common mode choke should be placed in close physical proximity to the control.

Unexpected faults may occur due to excessive charging current required for motor cable capacitance. If you use long motor leads and experience unexpected trips due to current overload conditions and are not sure how to correctly size and connect the optional load reactors, please contact your Baldor District representative. Baldor is always glad to assist.

Table 4-1 Fuse & Wire size / Terminal Torque Specifications

Hp	kW	Nominal Input Current	Fuse or MCB	Supply Cable Size		Nominal Output Current	Motor Cable Size		Max Motor Cable Length		Min Brake Resistor Value
		amps	amps	AWG	mm2	amps	AWG	mm2	feet	meters	ohms
500-600V +/-10% 3-Phase Input											
1	0.75	2.2	3	16	1	1.7	16	1	164	50	47
2	1.5	4.1	6	16	1	3.1	16	1	328	100	47
3	2.2	5.4	6	16	1	4.1	16	1	328	100	47
5	4	7.6	10	14	1.5	6.1	14	1.5	328	100	47
7.5	5.5	11.7	16	12	2.5	9	12	2.5	328	100	47
10	7.5	16.1	20	12	2.5	14	12	2.5	328	100	22
15	11	17.3	20	10	4	18	12	2.5	328	100	22
20	15	24.1	25	10	4	24	10	4	328	100	22
30	22	46.6	63	6	10	39	6	10	328	100	12
40	30	54.1	63	4	16	46	6	10	328	100	12
60	45	69.6	80	3	25	62	4	16	328	100	12
Control Terminal Torque Settings of 4.5 lb-in (0.5 Nm) Power Terminal Torque Settings of 9 lb-in (1 Nm)											

For UL compliance Motor Cable to be Copper 75°C and Fuse current rating defined by ratings marked ()*. Wire size is based on 40°C surrounding temperature and fuses are based on 45°C surrounding temperature, max continuous output and no harmonic current.

4.4.7 M-Contactor Connections

If required by local codes or for safety reasons, an M-Contactor (motor circuit contactor) may be installed. However, incorrect installation or failure of the M-contactor or wiring may damage the control. If an M-Contactor is installed, the control must be disabled for at least 200msec before the M-Contactor is opened or the control may be damaged. M-Contactor connections are shown in Figure 4-3.

CAUTION: If an M-Contactor is installed, the control must be disabled for at least 200msec before the M-Contactor is opened. If the M-Contactor is opened while the control is supplying voltage and current to the motor, the control may be damaged. Before the control is enabled, the M-Contactor must be closed for at least 200msec.

Figure 4-3 Motor Connections and Optional Connections

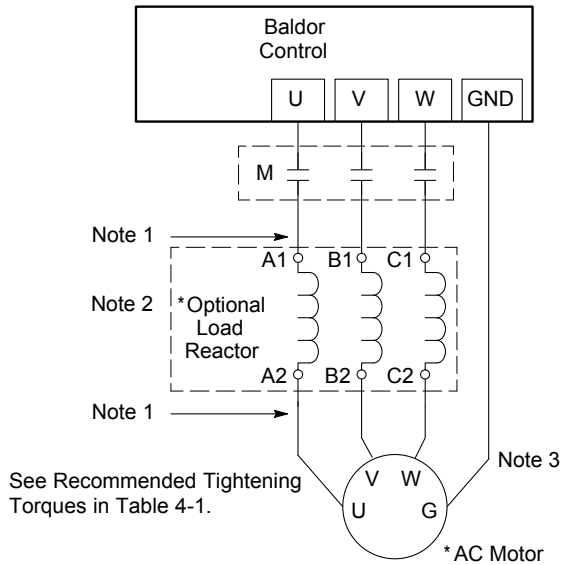

* Optional components not provided with control.

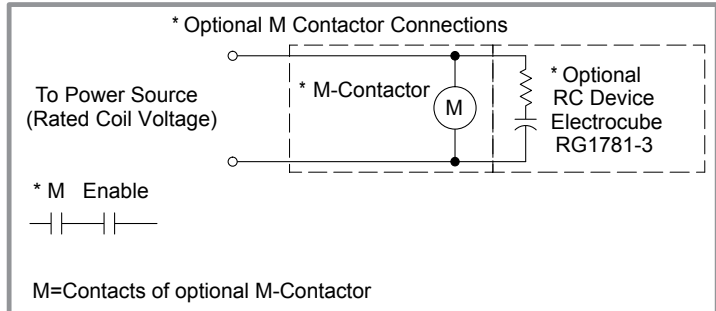

- Notes:
1. Metal conduit should be used. Connect conduits so the use of Load Reactor or RC Device does not interrupt EMI/RFI shielding.
 2. See Line/Load Reactors described previously in this section.
 3. Use same gauge wire for ground as for U, V and W.

Chapter 5

Control Wiring

5.1 Control Board Connections

Analog and Digital input and output connections are made at the Control Wiring Terminals shown in Figure 5-1.

Control wire connections can be made using shielded twisted pair #18 AWG (0.8mm²) wire minimum. The cable must also have an overall shield and not exceed 100 feet (30m) in length. Control wire cables must be separated from power wiring. Separate parallel runs of control cables and power cables by at least 3". Cross power wires at right angles only. Insulate or tape ungrounded end of shields to prevent contact with other conductors or ground.

Figure 5-1 Control Terminals

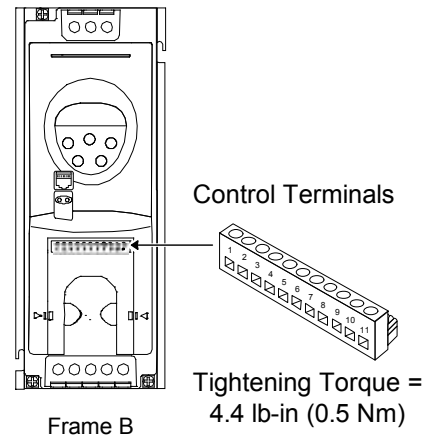

Table 5-1 Control Terminal Descriptions

Terminal	Signal Description
1	+24VDC (@ 100mA)
2	Digital In1 (8-30VDC)
3	Digital In2 (8-30VDC) / Digital Output 3 (24V, 10mA max.)
4	Digital In3 (8-30VDC) / Analog In2 (0-10VDC, 0-20mA or 4-20mA)
5	+24VDC (@ 100mA) Reference for Potentiometer (1kohm minimum)
6	Analog In1 (0-10VDC, 0-20mA or 4-20mA) / Digital In4 (8-30VDC)
7	Common (terminals 7 & 9 are connected)
8	Analog Output (0-10VDC @ 20mA max.) / Digital Output (0-24VDC @ 20mA max.)
9	Common (terminals 7 & 9 are connected)
10	Relay Common
11	Relay N.O. Contact (rated 250VAC@6A; 30VDC@5A)

5.2 RJ11 Communication Connection

The RJ11 Data Port can be used as a RS485 Serial interface using Modbus RTU protocol. Serial Modbus networks use the RS485 PIN connection; see Appendix E for the communication protocols.

Figure 5-2 RJ11 Data Connection

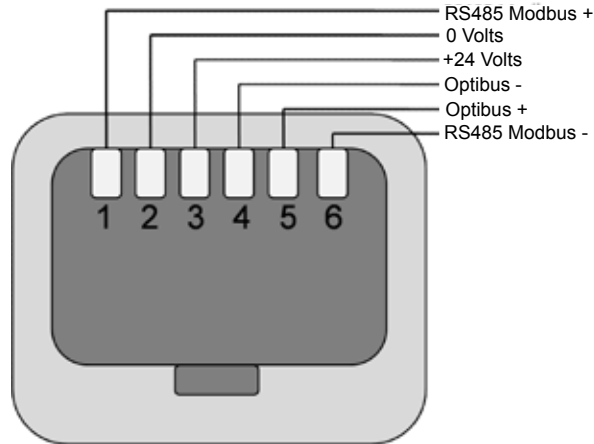

Table 5-2

Protocol	Modbus RTU
Error check	CRC
Baud rate	9600bps, 19200bps, 38400bps, 57600bps, 115200bps (default)
Data format	1 start bit, 8 data bits, 1 stop bits, no parity
Physical signal	RS485 (2-wire)

5.3 Analog and Digital Input Configurations

Parameters P-07 and P-08 can be set to allow various operating modes. Following are settings for these parameters.

5.3.1 Terminal Strip Mode (P1-07 = 0)

Table 5-3 Parameter P1-08 Control of Digital Inputs when P1-07=0

P1-08	Digital In 1 (Term 2)	Digital In 2 (Term 3)	Digital In 3 (Term 4)		Analog Input 1 (Term 6)
0	Open: Stop Closed: Run	Open: Bipolar Analog Speed Reference Closed: Preset Speed Reference	Open: Preset Speed 1 Closed: Preset Speed 2		Bipolar Analog Input 1
1	Open: Stop Closed: Run	Open: Preset Speed 1 Closed: Preset Speed 2	Open: Preset Speed 1/2 Closed: Preset Speed 3		Digital Input 4 (Term 6)
					Open: Preset Speed 1/2/3 Closed: Preset Speed 4
2	Open: Stop Closed: Run	Digital Input 2 (Term 3)	Digital Input 3 (Term 4)	Digital Input 4 (Term 6)	Speed Set point
		Open	Open	Open	Preset Speed 1
		Closed	Open	Open	Preset Speed 2
		Open	Closed	Open	Preset Speed 3
		Closed	Closed	Open	Preset Speed 4
		Open	Open	Closed	Preset Speed 5
		Closed	Open	Closed	Preset Speed 6
		Open	Closed	Closed	Preset Speed 7
Closed	Closed	Closed	Preset Speed 8		
3	Open: Stop Closed: Run	Open: Forward Closed: Reverse	Open: Bipolar Analog Ref Closed: Preset Speed 1		Bipolar Analog Input 1
4	Open: Stop Closed: Run	Open: Forward Closed: Reverse	Analog Input 2 (Speed Reference)		Bipolar Analog Input 1 (Torque reference)
5	Open: Stop Closed: Run	Open: Forward Closed: Reverse	Digital Input 3 (Term 4)	Digital Input 4 (Term 6)	Speed Set point
			Open	Open	Preset Speed 1
			Closed	Open	Preset Speed 2
			Open	Closed	Preset Speed 3
Closed	Closed	Preset Speed 4			
6	Open: Stop Closed: Run	Open: Forward Closed: Reverse	External trip input: Open: Trip Closed: No Trip		Bipolar Analog Input 1
7	Open: Stop Closed: Fwd Run	Open: Stop Closed: Rev Run	Open: Bipolar Analog Speed Ref Closed: Preset Speed 1		Bipolar Analog Input 1
8	Open: Stop Closed: Fwd Run	Open: Stop Closed: Rev Run	Open: Preset Speed 1 Closed: Bipolar Analog Speed Ref		Bipolar Analog Input 1
9	Open: Stop Closed: Run Fwd	Open: Stop Closed: Reverse Run	Digital Input 3 (Term 4)	Digital Input 4 (Term 6)	Preset Speed
			Open	Open	Preset Speed 1
			Closed	Open	Preset Speed 2
			Open	Closed	Preset Speed 3
Closed	Closed	Preset Speed 4			
10	Open: Stop Closed: Forward Run	Open: Stop Closed: Reverse Run	Open: Trip Closed: No Trip		Bipolar Analog Input 1

Table 5-3 Parameter P1-08 Control of Digital Inputs when P1-07=0 Continued

P1-08	Digital In 1 (Term 2)	Digital In 2 (Term 3)	Digital In 3 (Term 4)		Analog Input 1 (Term 6)
11	Open: Stop Closed: Run	Open: Bipolar Analog Speed Ref Closed: Preset Speed 1	Open: Trip Closed: No Trip		Bipolar Analog Input 1
12	Open: Stop Closed: Run	Open: Preset Speed 1 Closed: Bipolar analog speed ref	Open: Trip Closed: No Trip		Bipolar Analog Input 1
13	Normally Open (NO) Momentarily Close to Run	Normally Closed (NC) Momentarily Open to Stop	Open: Bipolar analog speed ref Closed: Preset Speed 1		Bipolar Analog Input 1
14	Normally Open (NO) Momentarily Close to Run Fwd	Normally Closed (NC) Momentarily Open to Stop	Normally Open (NO) Momentarily Close to Run Rev		Bipolar Analog Input 1
15	Open: Stop Closed: Run	Open: Forward Closed: Reverse	Open: Decel Ramp 1 (P1-11) Closed: Decel Ramp 2 (P2-25)		Bipolar Analog Input 1
16	Open: Stop Closed: Run	Open: Forward Closed: Reverse	Open: Decel Ramp 1 (P1-11) Closed: Decel Ramp 2 (P2-25)		Digital Input 4 (Term 6) Open: Preset Speed 1 Closed: Preset Speed 2
17	Normally Open (NO) Momentarily Close to Run Fwd	Normally Closed (NC) Momentarily Open to Stop	Normally Open (NO) Momentarily Close to Run Rev		Digital Input 4 (Term 6) Open: Preset Speed 1 Closed: Keypad Speed
18	Open: Stop Closed: Run	Digital Input 2 (Term 3)	Digital Input 3 (Term 4)	Preset Speed Ref	Digital Input 4 (Term 6)
		Open	Open	Preset Speed 1	Open: Preset Speed
		Closed	Open	Preset Speed 2	Closed: Keypad Speed
		Open	Closed	Preset Speed 3	
Closed	Closed	Closed	Preset Speed 4		
19	Open: Stop Closed: Run	Open : Bipolar Analog 1 Speed Ref Closed : Analog Input 2 Speed Ref	Analog Input 2		Bipolar Analog Input 1
20	Open: Stop Closed: Run	Digital Output: Drive Healthy = +24V	Open: Bipolar Analog Speed Ref Closed: Preset Speed 1		Bipolar Analog Input 1
21	Open: Stop Closed: Run	Digital Output: Drive Healthy = +24V	Open: Forward Closed: Reverse		Bipolar Analog Input 1
22	Open: Stop Closed: Run	Digital Output: Drive Healthy = +24V	Open: Trip Closed: No Trip		Bipolar Analog Input 1

Notes:

Negative Preset Speeds will be inverted if Run Reverse is selected.

The external trip input can be used to connect a motor thermistor between terminals 1 and 4.

When P1-07 = 0, P2-01 = 4 and P4-06 < > 2, Analog Input 2 is used for the speed reference.

When P1-07 = 0, P2-01 = 4 and P4-06 = 2, Bipolar Analog Input 1 is used for the speed reference and Analog Input 2 becomes the torque reference.

5.3.2 Keypad Mode (P1-07 = 1 or 2)

Table 5-4 Parameter P1-08 Control of Digital Inputs when P1-07=1 or 2

P1-08	Digital In 1 (Term 2)	Digital In 2 (Term 3)	Digital In 3 (Term 4)		Analog Input (Term 6)
0	Open: Stop	Closed: Remote UP Push-button	Closed: Remote DOWN Push-button		No Function
	Closed: Run	When stopped, closing inputs 2 & 3 starts the drive			
1	Open: Stop	Closed: Remote UP Push-button	External Trip Input :		Digital Input 4 Closed: Remote DOWN Push-button
	Closed: Run		Open: Trip Closed: No Trip		
2	Open: Stop	Closed: Remote UP Push-button	Open: Digital Speed Ref		Digital Input 4 Open: Forward Closed: Reverse
	Closed: Run		Closed: Preset Speed 1		
3, 9, 13, 14 & 16	Open: Stop	Closed: Remote UP Push-button	Closed: Remote DOWN Push-button		Digital Input 4 Open: Forward Closed: Reverse
	Closed: Run		When stopped, closing inputs 2 & 3 starts the drive		
10	Open: Stop	Open: Digital Speed Ref	External Trip Input		Bipolar Analog Input 1
	Closed: Run	Closed: Bipolar Analog Speed Ref	Open: Trip Closed: No Trip		
11	Open: Stop	Open: Digital Speed Ref	External Trip Input		Digital Input 4 Open: Forward Closed: Reverse
	Closed: Run	Closed: Preset Speed 1	Open: Trip Closed: No Trip		
12	Open: Stop	Open: Preset Speed 1	External Trip Input		Digital Input 4 Open: Forward Closed: Reverse
	Closed: Run	Closed: Digital Speed Ref	Open: Trip Closed: No Trip		
15	Open: Stop	Open: Digital Speed Ref	Open: Decel Ramp 1 (P1-11)		Digital Input 4 Open: Forward Closed: Reverse
	Closed: Run	Closed: Preset Speed 1	Closed: Decel Ramp 2 (P2-25)		
17	Open: Stop	Open: Digital Speed Ref	Open : Digital / Analog ref		Bipolar Analog Input 1
	Closed: Run	Closed: Bipolar Analog Speed Ref	Closed : Preset Speed 1		
18	Open: Stop Closed: Run	Open: Digital Speed Ref Closed: Preset Speed Ref	Digital Input 3 (Term 4)	Digital Input 4 (Term 6)	Preset Reference Preset Speed 1 Preset Speed 2 Preset Speed 3 Preset Speed 4
			Open	Open	
			Closed	Open	
			Open	Closed	
19	Open: Stop	Open: Digital Speed Ref	Analog Input 2		Digital Input 4 Open: Forward Closed: Reverse
	Closed: Run	Closed: Analog Input 2 Ref			
20, 21	Open: Stop	Digital Output:	Open: Digital Speed Ref		Digital Input 4 Open: Forward Closed: Reverse
	Closed: Run	Drive Healthy = +24V	Closed: Preset Speed 1		
22	Open: Stop	Digital Output:	External Trip Input		Digital Input 4 Open: Forward Closed: Reverse
	Closed: Run	Drive Healthy = +24V	Open: Trip Closed: No Trip		

Notes: By default, if the enable signal is present the drive will not Enable until the START button is pressed. To automatically enable the drive when the enable signal is present set P2-19 = 2 or 3. This then disables the use of the START & STOP buttons.

In keypad mode, the speed can be adjusted using the UP & DOWN keys on the built in keypad, or a remote mounted keypad, in addition to push buttons connected to the digital inputs.

The reverse input only functions under the following conditions:

- P1-07 = 1, P2-19 = 2 or 3. P2-35 must not be 2 or 3.
- P1-07 = 2. P 2-35 must not be 2 or 3.

The external trip input can be used to connect a motor thermistor by connecting between terminals 1 and 4

When P1-07 = 2 , the direction of motor can be reversed by:

- pressing the START button.
- closing the reverse input (When using a setting of P1-08 that includes this function).
- using a negative speed reference (e.g. select a preset speed of -10Hz).

Since all of these functions can be active at once, care must be taken to ensure the motor always turns in the correct direction.

5.3.3 PI Control Mode (P1-07 = 3)

Table 5-5 Parameter P1-08 Control of Digital Inputs when P1-07 = 3

P1-08	Digital In 1 (Term 2)	Digital In 2 (Term 3)	Digital In 3 (Term 4)	Analog Input 1 (Term 6)
0, 10, 13, 16, 18	Open: Stop Closed: Run	No Function	Analog Input 2	Bipolar Analog Input 1
11	Open: Stop Closed: Run	Open: PID control Closed: Preset Speed 1	External Trip Input Open: Trip Closed: No Trip	Bipolar Analog Input 1
12	Open: Stop Closed: Run	Open: Preset Speed 1 Closed: PID control	External Trip Input Open: Trip Closed: No Trip	Bipolar Analog Input 1
17	Open: Stop Closed: Run	Open: PID control Closed: Bipolar analog ref	Analog Input 2	Bipolar Analog Input 1
19	Open: Stop Closed: Run	Open: PID control Closed: Analog input 2	Analog Input 2	Bipolar Analog Input 1
20, 21	Open: Stop Closed: Run	Digital Output: Drive Healthy = +24V	Analog Input 2	Bipolar Analog Input 1
22	Open: Stop Closed: Run	Digital Output: Drive Healthy = +24V	External Trip Input Open: Trip Closed: No Trip	Bipolar Analog Input 1

Note: When P3-05 = 1, Bipolar analog input controls PID set point. The feedback must then be connected to Analog input 2 and P3-10 must be set to 0 (Default setting). The external trip input only functions when the feedback source is the Bipolar analog input (P3-10 = 1).

5.3.4 User PI Control Mode (P1-07 = 4)

Table 5-6 Parameter P1-08 Control of Digital Inputs when P1-07=4

P1-08	Digital In 1 (Term 2)	Digital In 2 (Term 3)	Digital In 3 (Term 4)		Analog Input 1 (Term 6)
0, 2, 4, 6, 9, 13, 16, 18	Open: Stop Closed: Run	No Function	No Function		Bipolar Analog Input 1
3	Open: Stop Closed: Run	Open: Forward Closed: Reverse	Open: Modbus Speed ref Closed: Preset Speed 1 ref		(No Function)
5	Open: Stop Closed: Run	Open: Modbus Speed Closed: Preset Speed	Digital Input 3 (Term 4) Open Closed Open Closed	Digital Input 4 (Term 6) Open Open Closed Closed	Preset Speed Preset Speed 1 Preset Speed 2 Preset Speed 3 Preset Speed 4
10	Open: Stop Closed: Run	Open: Master Speed ref Closed: Digital Speed ref	External trip input Open: Trip Closed: No Trip		Bipolar Analog Input 1 (No Function)
11	Open: Stop Closed: Run	Open: Master Speed ref Closed: Preset Speed 1	External trip input Open: Trip Closed: No Trip		Bipolar Analog Input 1 (No Function)
12	Open: Stop Closed: Run	Open: Master Speed ref Closed: Bipolar Analog ref	External trip input Open: Trip Closed: No Trip		Bipolar Analog Input 1 (No Function)
17	Open: Stop Closed: Run	Open: Master Speed ref Closed: Bipolar Analog ref	Open: Modbus / Analog Ref Closed: Preset Speed 1		Bipolar analog input (No Function)
19	Open: Stop Closed: Run	Open: Master Speed ref Closed: Analog Input 2 ref	Analog Input 2		Bipolar Analog Input 1 (No Function)
20, 21	Open: Stop Closed: Run	Digital Output: Drive Healthy = +24V	Open: Master Speed ref Closed: Preset Speed 1		Bipolar Analog Input 1 (No Function)
22	Open: Stop Closed: Run	Digital Output: Drive Healthy = +24V	External trip input Open: Trip Closed: No Trip		Bipolar Analog Input 1 (No Function)







Chapter 6

Using the Keypad

6.1 Keypad Components



This chapter provides an overview of the integrated keypad and how to use it to program the VS1STS drive. The controls are shown in Table 6-1.

Table 6-1 Operator Interface Description

Key	Name	Description
	Display	6 Digit seven segment display. Display of parameter numbers, values, error messages and other information.
	Start	Starts motor if Direction command and Speed reference are set. Only active if P1-07 is set to allow keypad control and when P2-19 is not set for 2 or 3. Programmable to change the motor direction if pressed while running.
	Stop / Reset	Stops the drive when in Keypad mode only. Active when P1-07=1 or 2 and when P2-19 is not set to 2 or 3. Resets any active faults, if fault condition has been cleared.
	Enter / Program	Momentarily press to view available displays. Pressing and holding the ENT Key for approximately 2 Seconds or more will enter the programming mode or escape back out of the programming mode.
	Increase	During operation increases the speed reference. (Active in keypad mode). Pressing for a period of time will increase the reference value rate of change. In edit mode, navigates between parameters and increments parameter values.
	Decrease	During operation decreases the speed reference. (Active in keypad mode). Pressing for a period of time will increase the reference value rate of change. In edit mode, navigates between parameters and decrements parameter values.

6.2 Changing Parameters

To change a parameter value press and hold the  ENT/PROG key for > 2 seconds while the drive displays *StoP*. The display changes to *P 1-01*, indicating parameter 01. Press and release the ENT/PROG key to display the value of this parameter.

























Use the  UP and  DOWN arrow keys to change to the required value. Press and release the ENT/PROG key once more to store the change. Press and hold the ENT/PROG key for > 2 second to return to operational mode. The display shows *StoP* if the drive is stopped or the real-time information (for example speed) if the drive is running.

6.3 Reset Factory Default Settings

Press the  UP,  DOWN,  STOP and  START keys simultaneously for > 2 seconds. The display shows *P-dEF* indicating the drive has reset itself to factory default parameters. Press the STOP button to acknowledge and reset the drive.

6.4 Advanced Keypad Operation Short Cuts

Table 6-2 Advanced Keypad Short Cuts

Function	Display shows	Press	Result	Example
Fast Selection of Parameter Groups Note: Parameter Group Access must be enabled (P1-14=101)	Px-xx	 + 	The next highest Parameter group is selected	Display shows P 1-10 Press  +  Display shows P 2-01
	Px-xx	 + 	The next lowest Parameter group is selected	Display shows P 2-26 Press  +  Display shows P 1-01
Select lowest Group Parameter	Px-xx	 + 	The first Parameter of a group is selected	Display shows P 1-10 Press  +  Display shows P 1-01
Set Parameter to minimum value	Any numerical value (While editing a parameter value)	 + 	The Parameter is set to the minimum value	When editing P1-01 Display shows 50_0 Press  +  Display shows 0_0
Adjusting individual digits within a parameter value	Any numerical value (While editing a parameter value)	 + 	Individual Parameter digits can be adjusted	When editing P1-10 Display shows 0 Press  +  Display shows _0 Press  Display shows 10 Press  +  Display shows _10 Press  Display shows 1 10 Etc...

6.5 Terminal Control

When delivered, the VS1STS is set to operate in terminal control mode and all parameters (P-xx) have the default values as indicated in Chapter 7 Parameters. Connect the motor to the drive, checking star/delta connection for the voltage rating.

1. Remove all power from the control.
2. Connect a control switch between the control terminals 1 and 2 ensuring that the contact is open (drive disabled).
3. Connect a potentiometer (1k Ω min to 10 k Ω max) between terminals 5 and 7, and the wiper to terminal 6.
4. With the potentiometer set to zero, switch on the power supply to the drive.
The display will show *StoP*.
5. Enter motor data from motor nameplate:
 - P1-01 = motor rated voltage
 - P1-02 = motor rated current
 - P1-03 = motor rated frequency
 - P1-04 = motor rated speed
6. Close the control switch between terminals 1-2. The drive is now 'enabled' and the output frequency/speed are controlled by the potentiometer.
7. On first enable from factory default parameters, the VS1STS will carry out an Auto tune (as described in Section 6.7), and the display shows *Auto-t*. Leave the control switch closed and allow this to complete.
8. Following completion of the Auto tune, the display shows zero speed in Hertz (*H 0.0*) with the potentiometer turned to minimum.
9. Turn the potentiometer to maximum. The motor will accelerate to 60Hz (the default value of P1-06) under the control of the accelerating ramp time P1-10. The display shows 60Hz (*H 60.0*) at max speed.
10. To display motor current (A), briefly press the ENT/PROG key.
11. Press ENT/PROG again to return to speed display.
12. To stop the motor, either turn the potentiometer back to zero or disable the drive by opening the control switch (terminals 1-2).
13. If the enable/disable switch is opened the drive will decelerate to stop at which time the display will show *StoP*. If the potentiometer is turned to zero with the enable / disable closed the display will show *H 0.0*. (0.0Hz), if left like this for 20 seconds the drive will go into standby mode, display shows *Stndby*, waiting for a speed reference signal.

6.6 Keypad Control

To allow the VS1STS to be controlled from the keypad in a forward direction only, set P1-07 =1:

1. Connect Motor as for terminal control above.
2. Enable the drive by closing the switch between control terminals 1 & 2. The display will show *StoP*.
3. Press the START key. If this is the first enable from factory default parameters, the drive will carry out an Auto tune as described in section 6.7. On completion of the Auto tune, the display shows *H 0.0*.
4. Press the UP arrow to increase speed.
5. The drive will run forward, increasing speed until the UP arrow is released. The rate of acceleration is controlled by the setting of P1-10, check this before starting.
6. Press the DOWN arrow to decrease speed. The drive will decrease speed until DOWN is released. The rate of deceleration is limited by the setting in P1-11.
7. Press the STOP key. The drive will decelerate to rest at the rate set in P1-11.
8. The display will finally show *StoP* at which point the drive is disabled.
9. To preset a target speed prior to enable, press the DOWN arrow key while the drive is stopped. The display will show the target speed, use the UP & DOWN arrow keys to adjust as required then press the STOP key to return the display to *StoP*.
10. Pressing the START key will start the drive accelerating to the target speed.
Setting P1-07=2 allows the VS1STS to be controlled in a forward and reverse direction from the keypad.
11. Operation is the same as when P1-07=1 for start, stop and changing speed.
12. Press the START key. The display changes to *H 0.0*.
13. Press the UP arrow to increase speed the drive will run forward, increasing speed until the UP arrow is released.
Acceleration is limited by the setting in P1-10. The maximum speed is the speed set in P1-06.
14. To reverse the direction of rotation of the motor, press the START key again.

6.7 Motor Auto tuning

The VS1STS uses a sophisticated Voltage Vector Control Method as the factory default setting to ensure best possible motor operation. This control method requires the VS1STS to carry out an auto tune to measure certain motor parameters prior to operation, to ensure this function operates correctly, and reduce the risk of nuisance tripping. While the auto tune procedure does not drive or spin the motor, the motor shaft may still turn. It is not normally necessary to uncouple the load from the motor; however the user should ensure that no risk arises from the possible movement of the motor shaft.

6.7.1 Auto tune after Factory Reset or from Factory Set Parameters

Following a factory reset (See Section 6.3), the correct data from the motor nameplate should be entered in P1-01 (Motor Rated Voltage), P1-02 (Motor Rated Current) and P1-03 (Motor Rated Frequency). Providing that P1-02 is adjusted from the factory default setting, the drive will automatically carry out an auto tune on the motor the first time it is enabled. During the auto tune, the display will show Auto-t. The test procedure may take several minutes to complete depending on the motor. Once the auto tune is completed, the drive will operate as normal, and no further auto tuning will be required unless the motor or drive control mode is changed (P4-01).

6.7.2 User Selected Auto tune

The user can program the drive to carry out an auto tune if required, as follows:

Ensure the motor nameplate values are correctly entered as described above.

Set P1-14 = 101 to allow access to Parameter Groups 2, 3 and 4.

Set P4-02 = 1 and press the button.

The auto tune will begin immediately when P4-02 is set to 1, and no external enable signal is required. During the auto tune procedure, the motor shaft may turn. It is not normally necessary to uncouple the load from the motor; however the user should ensure that no risk arises from the possible movement of the motor shaft.

6.8 Operating in Sensorless Vector Speed Control Mode

The VS1STS can be programmed by the user to operate in Sensorless Vector mode, which provides enhanced low speed torque, optimum motor speed regulation regardless of load and accurate control of the motor torque. In most applications, the default Voltage Vector control mode will provide adequate performance, however if Sensorless Vector operation is required, the following procedure should be followed:

Ensure the motor nameplate values are correctly entered in P1-01 (Motor Rated Voltage), P1-02 (Motor Rated Current) and P1-03 (Motor Rated Frequency)

Set P1-14 = 101 to allow access to parameter groups 2, 3 and 4.

The Motor Rated Power Factor from the motor nameplate **MUST** be entered in P4-05. If this data is not available, consult the motor manufacturer for guidance.

Set P4-01 = 0 to select Sensorless Vector Speed Control.

Set P4-02 = 1 to carry out an motor auto tune.

Parameters P4-03 and P4-04 have a significant effect on the behavior of the motor when operating in vector mode.

The auto tune will begin immediately when P4-02 is set to 1, and no external enable signal is required. During the auto tune procedure, the motor shaft may turn. It is not normally necessary to uncouple the load from the motor; however the user should ensure that no risk arises from the possible movement of the motor shaft.

6.9 Sensorless Vector Torque Control Mode

For applications which require the drive to control motor torque as opposed to motor speed, the drive can be programmed to operate in Torque Control mode. When operating this way, the drive internal ramp times (P1-10 and P1-11) are disabled except during starting and stopping.

Chapter 7

Parameter Descriptions

7.1 Overview

Parameters are presented in this Chapter and each setting is explained. Selecting P00 and pressing ENT/PROG accesses a read-only menu to monitor internal drive values. Once in the display view, the UP and DOWN arrows will scroll between the read only variables shown in Tables 7-5 and 7-8.

7.2 Basic Parameters - Parameter Group 1

Table 7-1 Basic Parameters - Parameter Group 1

Par No.	Description	Range	Units	Default	Explanation
P1-01	Motor Rated Voltage	0, 20 to 600	Volts	575	Rated (nameplate) voltage of the motor (Volts).
P1-02	Motor Rated Current	25% -100% of drive rated current	Amps	Drive rating	Enter the rated (nameplate) current of the motor. This value is used for overload protection.
P1-03	Motor Rated Frequency	25Hz to 2000Hz	Hz	60	Enter the rated (nameplate) frequency of the motor.
P1-04	Motor Rated Speed	0 to 60000 rpm	Rpm	0	When non-zero, all speed related parameters are displayed in rpm. Enter the motor rated (nameplate) speed if this is required.
P1-05	Minimum Frequency / Speed	0.0 to P1-06	Hz or Rpm	0.0	Minimum speed limit – Hz or rpm. If P1-04 >0, the value entered is in Rpm.
P1-06	Maximum Frequency / Speed	P1-05 to 5*P1-03 (max 2000Hz)	Hz or Rpm	60.0	Maximum speed limit – Hz or rpm. If P1-04 >0, the value entered is in Rpm.
P1-07	Terminal / Keypad / PID / Drive Control Mode Selection	0: Terminal control 1: Keypad control – fwd only 2: Keypad control – fwd and rev 3: PID Control 4: Modbus RTU Control	-	0	Primary Control Mode of the drive. 0: Terminal control 1: Uni-directional keypad control. Keypad START button does not reverse direction. 2: Bi-directional keypad control. Keypad START button toggles between forward and reverse. 3: User PID control with external feedback signal. 4: Modbus RTU Control.
P1-08	Digital Input Function Select	0 to 22	-	0	Defines the function of the digital inputs depending on the control mode setting in P1-07. See Tables 5-3, 5-4, 5-5 and 5-6 for more information.

Table 7-1 Basic Parameters - Parameter Group 1 Continued

Par No.	Description	Range	Units	Default	Explanation
P1-09	Stop Mode Select	0: Ramp to stop with power loss ride through 1: Coast to stop 2: Ramp to stop with 'fast stop' on input power loss	-	0	0: When the drive enable signal is removed, the drive will ramp to stop at the rate set in P1-11. If the mains supply is lost, the drive will try to continue running by reducing the speed of the load using the load as a generator. 1: When the enable signal is removed from the drive, the motor will coast (freewheel) to stop. 2: When the drive enable signal is removed, the drive will ramp to stop at the rate set in P1-11. If the mains supply is lost, the drive will ramp to stop using the P2-25 deceleration ramp time.
P1-10	Acceleration Ramp Time	0.0 to 3000.0	Seconds	5.0	Acceleration ramp time from 0 to base speed (P1-03) in seconds
P1-11	Deceleration Ramp Time	0.0 to 3000.0	Seconds	5.0	Deceleration ramp time from base speed (P1-03) to standstill in seconds. When set to zero, fastest possible ramp time without trip is activated.
P1-12	Energy Optimizer	0: Disabled 1: Enabled	-	0	When enabled, automatically reduces applied motor voltage on light load. Minimum value is 50% of nominal rated voltage (P1-01).
P1-13	Trip Log	Last four trips stored	-	Read only	Previous 4 trips stored in order of occurrence, the most recent first. Press UP or DOWN to step through all four. The most recent trip is displayed first. UV trip is only stored once.
P1-14	Extended Menu Access	Code 0 to 30000	-	0	Set to "101" (default) for extended menu access. Change code in P2-37 to prevent unauthorized access to the Extended Parameter Set.

7.3 Extended Parameters

7.3.1 Parameter Group 2 – Extended Parameters

Table 7-2 Parameter Group 2 - Extended Parameters

Par No.	Description	Range	Units	Default	Explanation
P2-01	Preset Speed 1	-P1-06 to P1-06	Hz / Rpm	50.0 (60.0)	Sets the speed the drive runs at when Preset Speed 1 is selected.
P2-02	Preset Speed 2	-P1-06 to P1-06	Hz / Rpm	0.0	Sets jog / preset speed 2
P2-03	Preset Speed 3	-P1-06 to P1-06	Hz / Rpm	0.0	Sets jog / preset speed 3
P2-04	Preset Speed 4	-P1-06 to P1-06	Hz / Rpm	0.0	Sets jog / preset speed 4
P2-05	Preset Speed 5	-P1-06 to P1-06	Hz / Rpm	0.0	Sets jog / preset speed 5
P2-06	Preset Speed 6	-P1-06 to P1-06	Hz / Rpm	0.0	Sets jog / preset speed 6
P2-07	Preset Speed 7	-P1-06 to P1-06	Hz / Rpm	0.0	Sets jog / preset speed 7
P2-08	Preset Speed 8	-P1-06 to P1-06	Hz / Rpm	0.0	Sets jog / preset speed 8
P2-09	Skip Frequency	P1-05 to P1-06	Hz / Rpm	0.0	Center point of skip frequency band set up in conjunction with P2-10
P2-10	Skip Frequency Band	0 to P1-06	Hz / Rpm	0.0	Width of skip frequency band centered on frequency set in P2-09
P2-11	Analog Output / Digital Output 1 Function Select	Digital Output Mode 0: Drive Enabled 1: Drive Healthy 2: Motor at Target Speed 3: Motor Speed >0 4: Motor Speed >= Limit 5: Motor Torque >= Limit 6: 2nd Analog Input >= Limit Analog Output Mode 7: Motor Speed 8: Motor Torque 9: Motor Power 10: Motor Current		7	Digital Output Mode Logic 1 = +24V DC 0: Logic 1 when the drive is enabled (Running) 1: Logic 1 When no Fault condition exists on the drive 2: Logic 1 when the motor speed matches the set point speed 3: Logic 1 when the motor runs above zero speed Options 4 to 6: the Digital output is enabled using the level set in P2-12h and P2- 12L Analog Output Mode 7: Motor Speed, 0 to 10V = 0 to P1-06 8: Motor torque, 0 to 10V = 0 to 200% of motor rated torque 9: Motor power, 0 to 10V = 0 to 150% of drive rated power 10: Motor Current, 0 to 10V = 0 to 200% of P1-02

Table 7-2 Parameter Group 2 - Extended Parameters Continued

Par No.	Description	Range	Units	Default	Explanation
P2-12h	Digital Output Control High Limit	0.0 to 200.0	%	100.0	With P2-11 = 4 to 6, Digital Output 1 is set to Logic 1 (+24V DC) when the value set in P2-12h is exceeded, and returns to Logic 0 (0V) when the selected value reduces below the limit set in P2-12L
P2-12L	Digital Output Control Low Limit	0.0 to P2-12h	%	100.0	
P2-13	User Relay Output Function Select	0: Drive Enabled 1: Drive Healthy 2: Motor at Target Speed 3: Motor Speed >0 4: Motor Speed >= Limit 5: Motor Torque >= Limit 6: 2nd Analog Input >= Limit		1	Selects the function assigned to the relay output. 0: Logic 1 when the drive is enabled (Running) 1: Logic 1 When no Fault condition exists on the drive 2: Logic 1 when the motor speed matches the set point speed 3: Logic 1 when the motor runs above zero speed Options 4 to 6 : the Digital output is enabled using the level set in P2-14h and P2-14L
P2-14h	Relay Output Control High Limit	0.0 to 200.0	%	100.0	With P2-13 = 4 to 6, the User Relay Output is set to Logic 1 (+24V DC) when the value set in P2-14h is exceeded, and returns to Logic 0 (0V) when the selected value reduces below the limit set in P2-12L
P2-14L	Relay Output Control Low Limit	0.0 to P2-14h	%	100.0	
P2-15	Relay Output Mode	0: Normally Open 1: Normally Closed	-	0	Inverts the operating status of the User Relay 0: Logic 1 = Relay Contacts Closed 1: Logic 1 = Relay Contacts Open The drive must be powered for the contacts to close
P2-16	Zero Speed Holding Time	0.0 to 60.0	Seconds	0.2	Determines the time for which the drive output is held at zero speed when stopping, before the drive output is disabled.
P2-17	Start Mode Select	Edge-r Auto-0 Auto-1 to 5	-	Auto-0	Edge-r: Following Power on or reset, the drive will not start if Digital Input 1 remains closed. The Input must be closed following a power on or reset to start the drive. Auto-0: Following a Power On or Reset, the drive will automatically start if Digital Input 1 is closed. Auto 1 to 5: Following a Fault, the drive will make up to 5 attempts to restart at 20 second intervals. The drive must be powered down to reset the counter.

Table 7-2 Parameter Group 2 - Extended Parameters Continued

Par No.	Description	Range	Units	Default	Explanation
P2-18	Spin Start Enable	0: Disabled 1: Enabled	-	0	When enabled, on start up the drive will attempt to determine if the motor is already rotating, and will begin to control the motor from its current speed. A short delay may be observed when starting motors which are not turning.
P2-19	Keypad Restart Mode	0: Minimum Speed, Edge-r 1: Previous Speed, Edge-r 2: Minimum Speed, Auto-r 3: Previous Speed, Auto-r Note: If set to 2 or 3, the status of Digital Input 1 controls drive to Start or Stop (overrides Parameter P1-07). The Stop and Start button on the drive will not operate in this case.	-	1	Active when P1-07 = 1 or 2 0: Following a stop and restart, the drive will run at minimum speed. 1: Following a stop and restart, the drive will run at the last set point speed. 2: As per setting 0, except that the Run command will be determined by the status of Digital Input 1, and the user is not required to press the keypad start button. 3: As per setting 1, except that the Run command will be determined by the status of Digital Input 1, and the user is not required to press the keypad start button.
P2-20	Standby Mode	0.0: Disabled 0.1 to 60.0	Seconds	0.0	When P2-20 >0, the drive enters standby mode if the minimum speed is maintained for the time period set in P2-20. Note: P2-16 must be set to zero for standby mode to operate.
P2-21	Display Scaling Factor	0.000 to 30.000	-	0.000	Disabled if P2-21 is set to 0. If P2-21 is set >0, the variable selected in P2-22 is multiplied by the factor entered in P2-21, and displayed while the drive is running.
P2-22	Display Scaling Source	0: 2nd Analog Input 1: Motor Speed 2: Motor Torque 3: Motor Current	-	0	
P2-23	Brake Circuit Enable	0: Disabled 1: Enabled, Low Duty 2: Enabled, High Duty 3: Enabled, No Protection	-	0	Enables the internal brake chopper. Settings 1 and 2 provide software monitoring of the braking power consumption. Setting 3 disables the protection, and externally monitoring must be used.
P2-24	Effective Switching Frequency	4 to 16 / 24 / 32 / Auto Drive Power Rating Dependent	KHz	16 8 4	Effective power stage switching frequency. Higher frequencies reduce the audible 'ringing' noise from the motor, and improve the output current waveform, at the expense of increased drive losses.

Table 7-2 Parameter Group 2 - Extended Parameters Continued

Par No.	Description	Range	Units	Default	Explanation
P2-25	2nd Deceleration Ramp Time	0.0 to 3000.0	Seconds	0.0	Deceleration 2nd ramp down time Selected Automatically on mains power loss if P1-09 = 2 Can also be selected by digital inputs, dependent on P2-01 setting. When set to 0, the drive decelerates as quickly as possible, while preventing an over voltage trip.
P2-26	Modbus Communication Baud Rate	t9.6, t19.2, t38.4, t57.6, t115.2 r9.6, r19.2, r38.4, r57.6, r115.2	Kbaud	t115.2	Modbus RTU serial data link communication Baud Rate. A 't' Prefix indicates the drive will trip if communication with the network master is lost, after a preset time period. An 'r' Prefix indicates that the VS1STS will Ramp to stop in the event of a loss of communication with the network master, after a preset time period.
P2-27	Drive Communication Address	0: Disabled 1 to 63	-	1	Sets the communication address for the drive when connected on a Modbus Network.
P2-28	Master / Slave Mode Select	0: Slave Mode 1: Master Mode	-	0	When in Master Mode, the drive transmits its operational status via the serial data link. All drives on the data link must have unique addresses. Only one drive can be programmed as a Master.
P2-29	Master / Slave Speed Reference Scaling Factor	0 to 500.0	%	100.0	Scaling factor applied to any speed reference on the serial data link, e.g. in Master / Slave operation, a Slave drive will apply this scaling factor to the transmitted Master speed reference.
P2-30	Bipolar Analog Input Format	U 0-24 = 0 - 24VDC U 0-10 = 0 - 10VDC -10 -10 = -10 to + 10VDC -24 -24 = -24 to + 24VDC	-	U 0-24	Configures the analog input signal to match the reference connected to terminal 6. Only voltage signals can be directly connected, mA reference signals require an external 500R resistor connection.
P2-31	Bipolar Analog Input Scaling	0.0 to 500.0	%	100.0	Scales the analog input by this factor, e.g. if P2-30 is set for 0 – 10V, and the scaling factor is set to 200.0%, a 5 volt input will result in the drive running at maximum speed (P1-06).
P2-32	Bipolar Analog Input Offset	-500.0 to 500.0	%	0.0	Sets an offset, as a percentage of the full scale range of the input, which is applied to the analog input signal.

Table 7-2 Parameter Group 2 - Extended Parameters Continued

Par No.	Description	Range	Units	Default	Explanation
P2-33	2nd Analog Input Format	<i>d</i> 0-24 = Digital <i>U</i> 0-10 = 0 to 10VDC <i>R</i> 4-20 = 4 to 20mA <i>R</i> 0-20 = 0 to 20mA	-	<i>d</i> 0-24	Selects the format for the 2nd analog input. Selecting <i>d</i> 0-24 sets the input up as a digital input.
P2-34	2nd Analog Input Scaling	0 to 500.0	%	100.0	Scales the 2nd analog input by the factor set in this parameter.
P2-35	Digital Speed Reference Scaling Control	0: Disabled (No Scaling) 1: Scaled by P2-29 2: Scaled by P2-29, then bipolar analog input added as an offset 3: Scaled by P2-29 and by bipolar analog input	-	0	Active in Keypad mode (P1-07 = 1 or 2) and Master / Slave mode only. 1: Actual Speed = Digital Speed x P2-29 2: Actual Speed = (Digital Speed x P2-29) + bipolar analog reference 3: Actual Speed = Digital Speed x P2-29 x bipolar analog reference
P2-36	Analog Output Format	<i>U</i> 0-10 = 0 to 10V <i>R</i> 4-20 = 4 to 20mA <i>U</i> 10-0 = 10 to 0V <i>R</i> 20-4 = 20 to 4mA	-	<i>U</i> 0-10	Selects the analog output signal format.
P2-37	Extended Menu Access Code	0 to 9999	-	101	Defines the access code which must be entered in P1-14 to access parameter groups above Group 1.
P2-38	Parameter Lock	0: Unlocked 1: Locked	-	0	When locked, all parameter changes are prevented.
P2-39	Hours Run Counter	0 to 99999	Hours	Read Only	Indicates the number of hours for which the drive has run.
P2-40	Drive Type / Rating	N/A	-	Read Only	Read only parameter, showing the drive type and power rating.

7.3.2 Parameter Group 3 – PID Control

Table 7-3 Parameter Group 3 - PID Control

Par No.	Description	Range	Units	Default	Explanation
P3-01	Proportional Gain	0.1 to 30.0	-	2.0	PID Controller Proportional Gain. Higher values provide a greater change in the drive output frequency in response to small changes in the feedback signal. Too high a value can cause instability.
P3-02	Integral Time Constant	0.0 to 30.0	Seconds	1.0	PID Controller Integral Time. Larger values provide a more damped response for systems where the overall process responds slowly.
P3-03	Differential Time Constant	0.00 to 1.0	Seconds	0.00	PID Differential Time Constant
P3-04	PID Operating Mode	0: Direct 1: Inverse	-	0	Direct operation – Motor speed increases with an increase in the feedback signal Inverse Operation – Motor speed decreases with an increase in the feedback signal.
P3-05	PID Set Point / Reference Select	0: Digital 1: Analog	-	0	Selects the source for the PID Reference / Setpoint 0: P3-06 is used 1: Bipolar analog input is used
P3-06	PID Digital Reference	0.0 to 100.0	%	0.0	Sets the preset digital PID reference / set point.
P3-07	PID controller high limit output	P3-08 to 100.0	%	100	Limits the maximum value output from the PID controller.
P3-08	PID Controller Low Limit Output	0 to P3-07	%	0	Limits the minimum output from the PID controller
P3-09	User PID Output Limit / Function Control	0: Digital output limits 1: Analog Upper Limit 2: Analog Lower Limit 3: PID added to Bipolar analog input reference	-	0	0: PID output range limited by P3-07 & P3-08 1: PID maximum output limited by the signal applied to the bipolar analog input 2: PID minimum output limited by the signal applied to the bipolar analog input 3: PID output is added to the speed reference applied to the bipolar analog input
P3-10	PID Feedback Source Select	0: 2nd Analog Input 1: Bipolar analog input	-	0	Selects the source of the PID feedback signal.

7.3.3 Parameter Group 4 – How Performance Motor Control

Table 7-4 Parameter Group 4 - How Performance Motor Control

Par No.	Description	Range	Units	Default	Explanation
P4-01	Control Mode	0: Vector Speed Control 1: Vector Torque Control 2: V/f Speed Control	-	2	Selects the motor control method. An auto tune must be performed following a change.
P4-02	Motor Parameter Auto Tune	0: Disabled 1: Enabled	-	0	When set to 1, the drive immediately carries out a non-rotating auto tune to measure the motor parameters for optimum control and efficiency.
P4-03	Speed Controller Proportional Gain	1 to 4096	-	300	Sets the proportional gain value for the speed controller. Too high a value may cause overshoot when accelerating to set point speed, or instability of the motor output speed.
P4-04	Speed Controller Integral Time	0.010 to 1.000	Seconds	0.050	Set the integral time for the speed controller. Smaller values provide a faster response in reaction to motor load changes, at the risk of introducing instability.
P4-05	Motor Power Factor	0, 0.50 to 1.00	-	-	Motor nameplate power factor, which must be entered for Vector operation (P4-01 = 0 or 1).
P4-06	Torque Reference Source Select	0: Preset Value 1: Bipolar analog input 2: 2nd analog input 3: Modbus RTU 4: Master / Slave	-	0	When operating in vector mode (P4-01 = 0 or 1), selects the source of the torque reference.
P4-07	Maximum Torque Limit / Torque Reference	0.0 to 200.0	%	200.0	If P4-01 = 1 and P4-06 = 0, sets the preset torque reference If P4-01 = 0, sets the maximum torque limit.
P4-08	Minimum Torque Limit	0.0 to 150.0	%	0.0	Sets a minimum torque limit, see the warning below.
P4-09	V/F Characteristic Adjustment Frequency	0 to P1-03	Hz	0.0	When operating in V/f mode (P4-01 = 2), sets a frequency point at which the voltage applied in P4-10 is applied to the motor. Care must be taken to avoid overheating and damaging the motor when using this feature.
P4-10	V/F Characteristic Adjustment Voltage	0 to P1-01	-	0	In conjunction with P4-09, in V/f mode (P4-01 = 2), sets the voltage applied to the motor at the adjustment frequency set in P4-09.

7.3.4 Parameter Group 0 – Monitoring Parameters (Read Only)

Table 7-5 Parameter Group 0 – Monitoring Parameters (Read Only)

Par No.	Description	Range	Units	Default
P0-01	Bipolar Analog Input Value	-100 to 100	%	100% = max input voltage
P0-02	2nd Analog Input Value	0 to 100	%	100% = max input voltage
P0-03	Post Ramp Speed Reference	-500 to 500	%	100% = P1-03
P0-04	Digital Speed Reference	-P1-06 to P1-06	Hz / Rpm	Digital speed reference
P0-05	Torque Controller Reference	0 to 200	%	Torque reference set point
P0-06	PID Reference	0 to 100	%	PID reference / set point
P0-07	PID Feedback	0 to 100	%	PID controller feedback value
P0-08	PID Error	0 to 100	%	Actual PID error
P0-09	PID P Term	0 to 100	%	Proportional component
P0-10	PID I Term	0 to 100	%	Integral component
P0-11	PID D Term	0 to 100	%	Differential component
P0-12	PID Output	0 to 100	%	Output from PID controller
P0-13	Output Torque	0 to 200	%	100% = motor rated torque
P0-14	Magnetizing Current	Drive dependent	A	Motor RMS magnetizing current
P0-15	Rotor Current	Drive dependent	A	Rotor RMS current
P0-16	Field Strength	0 to 100	%	Magnetic field strength
P0-17	Stator Resistance	Drive dependent	Ohms	Phase to phase stator resistance
P0-18	Stator Inductance	Drive dependent	H	Stator inductance
P0-19	Rotor Resistance	Drive dependent	Ohms	Calculated rotor resistance
P0-20	DC Bus Voltage	0 to 1000	Volts	Internal DC Bus voltage
P0-21	Drive Temperature	0 to 120	°C	Measured heat sink temperature
P0-22	Supply Voltage L1 – L2	Drive dependent	Volts	Phase to phase supply voltage
P0-23	Supply Voltage L2 – L3	Drive dependent	Volts	Phase to phase supply voltage
P0-24	Supply Voltage L3 – L1	Drive dependent	Volts	Phase to phase supply voltage
P0-25	Estimated Rotor Speed	Drive dependent	Hz / Rpm	Vector mode, estimated motor speed
P0-26	kWh Meter	0 to 999.9	kWh	Cumulative energy consumption
P0-27	MWh Meter	0 to 60,000	MWh	Cumulative energy consumption
P0-28	Software ID – IO Processor	Drive dependent	-	Version number & checksum
P0-29	Software ID – Motor Control	Drive dependent	-	Version number & checksum
P0-30	Drive Serial Number	Drive dependent	-	Unique drive serial number

7.4 Advanced Parameters

The VS1STS contains advanced parameters described in this section. These parameters are not visible to end users unless P1-14 is set to a value of '702'. The parameters are list below.

7.4.1 Advanced Parameters - Parameter Group 5

Table 7-6 Advanced Parameters - Parameter Group 5

Par No.	Description	Range	Units	Default	Explanation
P5-01	Motor Stator Resistance (Rs)	Drive dependent	Ω	-	During an auto tune, the drive measures / calculates these parameters to optimize the motor control performance. The values can be adjusted by the user, however this may have a negative effect on the motor behavior, or cause unexpected results, and this is not recommended.
P5-02	Motor Rotor resistance (Rr)	Drive dependent	Ω	-	When set to 1, the drive immediately carries out a non-rotating auto tune to measure the motor parameters for optimum control and efficiency.
P5-03	Stator Inductance (Ls)	Drive dependent	-	-	
P5-04	Magnetizing Current (Id rms)	10% to 80% of motor rated current	A	-	
P5-05	Leakage coefficient (Sigma)	0.025 to 0.250	-	-	
P5-06	Reserved		-	-	
P5-07	Quick Rs Measurement Enable	0: Disable 1: Enable	-	1	<p>This parameter enables (1) or disables (0) the motor stator resistance measurement when the drive run signal is given. Since an auto-tune is usually carried out during the commissioning process, the motor is cold. Temperature dependent parameters (i.e. stator resistance) can vary significantly during operation.</p> <p>Whenever the drive is enabled from a stopped condition, the drive will start from the Auto-tuned (cold) parameters. To adjust for variance in stator resistance, the drive can perform a measurement on enable.</p> <p>A delay of one magnetization time constant (typically 100 – 200 ms) can be added before start up. This function is only active when the drive is in vector control mode.</p>

Table 7-6 Advanced Parameters - Parameter Group 5 Continued

Par No.	Description	Range	Units	Default	Explanation
P5-08	Reserved		-	-	
P5-09	Over Voltage Current Limit	0 to 100% of motor rated current	%	0	<p>This parameter is only valid in vector speed control mode. This parameter will come into function once the drive DC bus voltage increase over certain limit. This voltage limit is set internally just below the over voltage trip level. This parameter will effectively limit the output torque current in order to prevent large current going back to the drive, which may cause over voltage trip.</p> <p>A small value in this parameter will limit the motor control torque once drive DC bus over this control level. A higher value may cause big distortion on the motor current, which may cause an aggressive behavior of the motor.</p>
P5-10	Re-Generation Current Limit	0.0 to 200% of motor rated current	%	100.0	<p>This parameter defines the control current limit when motor in regenerating mode. The value in this parameter represents the percentage value of motor rated current that is defined in P1-08. The current limit that defined in this parameter will override the normal torque producing current limit when motor goes into regeneration mode.</p> <p>Too high a value may cause big motor current distortion and the motor may behavior aggressively once motor goes into regeneration mode. The output torque of the motor may reduce during regeneration if the value in this parameter is too small.</p>
P5-11	Pulse Width Limitation	0...500 (Time = value *16.67ns)	Ms	-	<p>This parameter is used to limit the minimum output pulse width, which can be used for long cable applications. Increasing the value of this parameter will reduce the risk of over-current trips on long motor cables, but will also reduce the maximum available output motor voltage for a given input voltage.</p>
P5-12	V/F Mode Magnetizing Period	0...2000ms	ms	-	<p>This parameter is used to set up a minimum delay time for the magnetizing current control in V/F mode when drive run signal is given. Too small a value may cause the drive to trip on over-current if the acceleration ramp is very short.</p>

7.4.2 Application Specific Parameters

Table 7-7 Application Specific Parameters

Par No.	Description	Range	Units	Default	Explanation
P6-01	Software Upgrade Enable	0: Disable 1: I/O En 2: DSP En	-	0	Enables the Application Macro loading / firmware upgrade process.
P6-02	Thermal Management Enable	0: Disable 1: Enable	-	0	When set to 1, the drive will automatically reduce the output switching frequency with increasing heat sink temperature, to reduce the risk of an over temperature trip.
P6-03	Auto-Reset Delay Time	1s...60	s	20	Sets the delay time allowed between consecutive reset attempts when Auto Reset is enabled (see P2-17).
P6-04	User Relay Speed Hysteresis Band	0.0 ... 25.0	%	0.3	This parameter defines a band around zero speed as a percentage of P1-03. When P2-11 or P2-13 = 2 or 3, output frequencies below this value are treated as 'zero speed'. This function is used to prevent "chatter" on the output if the operating speed coincides with the level at which the digital / relay output changes state. E.g. if P2-13 = 3, P1-06 = 50Hz and P6-04 = 5%, the relay contacts close above 2.5Hz.
P6-05	Encoder Feedback Enable	0: Disabled 1: Enabled	-	0	Enables Encoder Feedback.
P6-06	Encoder PPR	0 .. 10000	-	0	Sets the number of Pulses Per Revolution for the encoder
P6-07	Encoder Speed Error Limit	0.0 ... 50.0	%	5.0	This parameter defines the allowed speed error between the encoder feedback and the VS1STS own estimated rotor speed. When set to zero, the protection is disabled.

Table 7-7 Application Specific Parameters Continued

Par No.	Description	Range	Units	Default	Explanation
P6-08	Modbus Communication Loss Timer	0: disabled 1..60	s	2	<p>This parameter controls the behavior of the drive in the event of a loss of communication between drive and Modbus Network Master while the drive is operating. When set to zero, the drive will continue running if communication with the Modbus master is lost. When set to a value larger than zero, the drive will trip after the number of seconds specified in this parameter.</p> <p>This parameter is active regardless of the setting of P1-07; hence even if the Modbus Network Master is being used to monitor the drive rather than control it, a loss of communication will still cause the drive to trip.</p>
P6-09	Speed Droop Control	0.0 ...25.0% of P1-03	Hz	0	<p>This parameter only applies when the drive is in vector speed control mode. (P4-01=0) When set to zero, the speed droop control function is disabled. If P6-09 > 0, this parameter effectively defines a slip speed at motor rated output torque.</p> <p>The droop speed is the percentage value of P1-03. Depending on the motor load condition, the reference speed will be reduced by a certain droop value before going into the speed controller.</p> <p>See equations below: Droop speed = P6-09 * P1-03 Droop value = Droop speed * (Motor real torque / Motor rated torque) Speed controller input = Speed reference – Droop value</p>

Table 7-7 Application Specific Parameters Continued

Par No.	Description	Range	Units	Default	Explanation
P6-10	Brake Chopper Duty Cycle when Under Temperature	0.0...20.0	%	2.0	<p>This parameter defines the duty cycle applied to the brake chopper while the drive is in an under temperature trip state. A Brake resistor can be mounted to the drive heat sink, and used to warm the drive until the correct operating temperature is reached.</p> <p>This parameter should be used with extreme care, as incorrect adjustment may result in exceeding the rated power capacity of the resistor. External thermal protection for the resistor should always be used to avoid this risk.</p>
P6-11	Preset Speed Run Time On Enable	0.0..600.0	S	0.0	<p>Defines a time period for which, following an enable signal being applied to the drive, the drive will run at the speed programmed in Preset Speed 7 (P2-07). This feature can be used on pumps to provide a reverse spin on start up, to avoid potential blockages.</p>
P6-12	Preset Speed Run Time on Disable	0.0..600.0	S	0.0	<p>Defines a time period for which, following removal of the enable (Run) signal and the drive ramping to standstill, the drive will then operate at the speed set in Preset Speed 8 (P2-08). This feature can be used in applications such as underground PCP pumps to provide unwind of the driveshaft on stopping.</p>

7.4.3 Additional Parameter Group 0 – Monitoring Parameters

Table 7-8 Additional Parameter Group 0 - Monitoring Parameters

Par No.	Description	Range	Units	Default	Explanation
P0-31	Drive Serial Number #2				
P0-32	DSP Bootloader Version	E.g. “ 1.00”			
P0-33	Measured Cos phi	E.g. 0.78			
P0-34	Comms Error Count (DSP)	0 ... 65535			
P0-35	Configuration Register Value	Internal value			
P0-36	Digital Input Status	Internal value			
P0-37	Analog Out Internal Value	Internal value			
P0-38	Current Phase U Offset	Internal value			
P0-39	Current Phase U Ref	Internal value			
P0-40	Current Phase V Offset	Internal value			
P0-41	Current Phase V Ref	Internal value			
P0-42	Brake Resistor Max on Time	Time in milliseconds			
P0-43	Brake Resistor Duty Cycle	Internal value			
P0-44	Uq Internal Ref Value	Internal value			
P0-45	Ud Internal Ref Value	Internal value			
P0-46	Measured Spin Start Speed	Internal value			
P0-47	Calculated Slip Speed Value	Internal value (V/F mode only)			
P0-48	Hoist Boost Speed	Internal value			
P0-49	Rated Iq Internal Value	Internal value			
P0-50	Motor Voltage	V ph-ph (rms)			
P0-51	Switching Frequency Internal	Internal value			
P0-52	Speed Hysteresis Value	Internal value			
P0-53	PID DC Bus Feedback Value	0..4096			
P0-54	Modbus Comms Error	0 ... 65535			
P0-55	Modbus Speed Reference	Internal value			
P0-56	Droop Speed	Internal value			
P0-57	Encoder Speed	-P1-06 to P1-06	Hz / Rpm		Displays the encoder speed
P0-58	Speed Jump Zone	Internal value			
P0-59	Modbus Write Command Data Value	Register dependent			
P0-60	Motor Control Loop ID	0 ... 65535			

Chapter 8

Customizing Your Application

8.1 Simple Parameter Adjustments

Factory settings may give satisfactory performance, however certain adjustments may be beneficial.

Table 8-1

Adjustment	Parameter	Parameter Name
Motor Rated Volts	P1-01	The factory default setting P1-01 = 575 should be used unless voltage compensation is required.
Motor Rated Current	P1-02	Must be set to the value on the motor nameplate. P1-04 is optional. If this parameter is set to zero (default state), speed is displayed in Hz (otherwise, RPM).
Motor Rated Frequency	P1-03	
Motor Rated Speed	P1-04	
Minimum Speed	P1-05	Set P1-06 to the maximum speed and P1-05 to the minimum speed. These limits can also be negative for reverse speeds. If a non-zero minimum speed is set in P1-05, the motor will ramp to this minimum speed at the rate set in P1-10 as soon as the drive is enabled. Note: If P1-04 is set to a value other than "0", the value displayed will be in RPM.
Maximum Speed	P1-06	
Start/Stop Source	P1-07	Set as required by the application.
Speed Ref Source	P1-08	Set as required by the application.
Stop Mode	P1-09	Select method of stopping required when drive is disabled.
Acceleration Ramp	P1-10	Adjust as need for your application. Short Acceleration or Deceleration times may cause excess motor current and may result in it tripping or the motor stalling.
Deceleration Ramp	P1-11	
Analog Input Format	P2-30	Set as required by the application (0-10V, 10-0V, 4-20mA)

Chapter 9

Troubleshooting

The VS1STS constantly monitors its status and provides the following ways to determine the status of the drive and to troubleshoot problems that may occur:

- LED's on the drive
- Fault Codes displayed on seven segment display
- Drive monitor and status parameters
- Entries in the fault queue

9.1 Fault Codes

Fault codes indicate conditions within the drive that require immediate attention. The drive responds to a fault by initiating a coast-to-stop sequence and turning off motor power.

1. Note the fault code on the display. See Table 9-1 for a description of the fault and corrective actions. The cause must be corrected before the fault can be cleared.
2. Remove the condition which caused the trip and press the STOP key or re-enable the drive.
3. The drive will restart according to the mode selected by P2-19.
4. If the motor is stopped and the display shows STOP, there is no fault; the drive output is disabled and the drive is ready to run.

Read fault log as follows:

1. Press and hold the Enter/Program Key to enter program mode.
2. Use the Up / Down arrow keys to select P1-13 - Trip Log.
3. Press Enter/Program Key to access the fault log. The last four faults can be monitored using the Up / Down arrow keys to view.
4. The codes appear in the order they occurred with the first fault displayed being the most recent.

9.2 Periodic Inspection

A periodic inspection schedule for the drive and driven equipment promotes proper operation and reduces down time. The frequency of inspections depends on operating environment. Inspections should be conducted more frequently in hostile conditions where there might be high vibration, dust, dirt, high humidity, or corrosive atmosphere.

- Check for any loose mounting hardware and tighten to specified torque value.
- Check electrical connections are tight and secure.
- Check the cooling fan and heatsink for debris. Remove obstructions as necessary.

Table 9-1 Fault Descriptions and Corrective Actions

Fault Code	Description	Corrective Action
P-dEF	Factory Default Parameters Have Been Loaded	Press STOP key, drive is ready to configure for particular application.
O-I hO-1	Instantaneous Over Current on Drive Output Excess Load on the Motor Over Temperature on the Drive Heatsink	<p>If the fault occurs immediately when enabling the drive, disconnect the motor cable from the output terminals of the drive and restart the drive. If the fault re-occurs with no motor connected, contact your Baldor District Office. If the drive runs correctly without motor connected, check the motor, motor cable and any connections or junction boxes for phase – phase and phase – earth short circuits. Wherever possible, motors and connection cables should be checked with a high voltage insulation tester (Megga) prior to connection to the drive.</p> <p>Ensure that no switching devices, such as contactors or local isolators are switching during operation of the drive.</p> <p>Check the motor cable length does not exceed the specified maximum.</p> <p>Ensure the motor nameplate parameters are correctly entered, P1-01, P1-02, P1-03. If operating in Vector mode (P4-01 – 0 or 1), also check the motor power factor in P4-05.</p> <p>Ensure an autotune has been successfully completed for the connected motor.</p> <p>Check the load mechanically for a jam or stalled condition, or shock loads.</p> <p>Increase the ramp up time in P1-10.</p> <p>If operating in Vector mode (P4-01 – 0 or 1), reduce the speed loop gain in P4-03.</p>
I-L-trP	Drive Has Tripped on Overload After Delivering >100% of Value in P1-02 for a Period of Time	Check to see when the decimal points are flashing (drive in overload) and either increase acceleration rate or reduce the load. Check motor cable length is within spec. Ensure the motor nameplate parameters are correctly entered, P1-01, P1-02, and P1-03. If operating in Vector mode (P4-01 – 0 or 1), also check the motor power factor in P4-05. Ensure an autotune has been successfully completed for the connected motor. Check the load mechanically to ensure it is free, and no jams, blockages or other mechanical faults exist.
OI-b	Brake Circuit Over Current	Check the cabling to the brake resistor. Check the brake resistor value. Ensure minimum resistance values from the rating tables are observed.
OL-br	Brake Resistor Overload	Brake resistor overload. Increase deceleration time, reduce load inertia or add further brake resistors in parallel, observing the minimum resistance value for the drive in use.
PS-trP	Fast Over Current Trip	Check wiring to motor, look for Phase to Phase or Phase to Earth short circuit. Check drive temperature, additional space or cooling needed? Check drive is not forced into overload.
O_Uo It	Over Voltage on DC Bus	Supply problem, or increase decel ramp time P1-11.
U_Uo It	Under Voltage on DC Bus	This occurs routinely when power is switched off. If it occurs during running, check power supply voltage.
O-t	Heatsink Over Temperature	Check drive ambient temp. Additional space or cooling required.
U-t	Under Temperature	Trip occurs when ambient temperature is less than -10°C. Temperature must be raised over -10°C in order to start the drive.

Table 9-1 Fault Descriptions and Corrective Actions Continued

<i>th-FLt</i>	Faulty Thermistor on Heatsink	Refer to your Baldor District Office.
Fault Code	Description	Corrective Action
<i>E-trIP</i>	External Trip (on Digital Input 3)	E-trip requested on digital input 3. Normally closed contact has opened for some reason. If motor thermistor is connected check if the motor is too hot.
<i>SC-trP</i>	Comms Loss Trip	Check communication link between drive and external devices. Make sure each drive in the network has its unique address.
<i>P-LOSS</i>	Input Phase Loss Trip	Drive intended for use with a 3 phase supply has lost one input phase. Check incoming supply and fuses.
<i>Ph-IB</i>	Phase Imbalance	Mains incoming supply voltage has an imbalance of >3% for over 30 seconds. Check incoming supply and fuses.
<i>dRAM-F</i>	Internal Memory Fault	Parameters not saved, defaults reloaded. Try again. If the problem re-occurs, refer to your Baldor District Office.
<i>RE-F01</i>	Autotune Failed	Measured motor stator resistance varies between phases. Ensure the motor is correctly connected and free from faults. Check the windings for correct resistance and balance.
<i>RE-F02</i>		Measured motor stator resistance is too large. Ensure the motor is correctly connected and free from faults. Check that the power rating corresponds to the power rating of the connected drive.
<i>RE-F03</i>		Measured motor inductance is too low. Ensure the motor is correctly connected and free from faults.
<i>RE-F04</i>		Measured motor inductance is too large. Ensure the motor is correctly connected and free from faults. Check that the power rating corresponds to the power rating of the connected drive.
<i>RE-F05</i>		Measured motor parameters are not convergent. Ensure the motor is correctly connected and free from faults. Check that the power rating corresponds to the power rating of the connected drive.
<i>SPIN-F</i>	Spin Start Failure	Spin start function (P2-18=1) failed to detect motor speed Check motor and connections. Ensure motor speed is less than maximum speed (P1-06). Make sure motor base frequency (P1-03) is <100Hz.
<i>tor-OL</i>	Over Torque Trip	The user programmable torque limit has been exceeded. Refer to the Baldor District Office for further information.
<i>4-20 F</i>	4-20mA Input Signal Loss	The level of the 4-20mA signal applied to analog input 2 (Terminal 4) has dropped below the minimum threshold of 3mA. Check for wiring or signal transducer faults.

Appendix A

Technical Specifications

Table A-1 VS1STS Specifications

Input Ratings	Voltage	600VAC
	Voltage Range	450-660VAC
	Phase	Three Phase
	Frequency	50/60Hz \pm 5%
	Impedance	1% minimum from mains connection

Output Ratings	Horsepower	1-60HP, 600VAC, 3PH
	Overload Capacity	150% for 1 minute; 175% for 2 seconds
	Frequency	0-500Hz
	Voltage	0 to maximum input voltage (RMS)

Protective Features	Trip	Missing control power, over current, over voltage, under voltage, over temperature (motor or control), output shorted or grounded, motor overload
	Stall Prevention	Over voltage suppression, over current suppression
	External Output	LED trip condition indicators, 4 assignable logic outputs, 2 assignable analog outputs
	Short Circuit	Phase to phase, phase to ground
	Electronic Motor Overload	Meets UL508C (I ² T)

Environmental Conditions	Temperature	-10°C to 50°C De-rate 3% per degree C above 50°C to 55°C maximum surrounding temperature
	Cooling	Forced air
	Enclosure	IP20
	Altitude	Sea level to 3300 Feet (1000 Meters) De-rate 2% per 1000 Feet (303 Meters) above 3300 Feet
	Humidity	10 to 90% RH Non-Condensing
	Shock	1G
	Vibration	0.5G at 10Hz to 60Hz
	Storage Temperature	-20°C to +65°C
Duty Cycle	1.0	

Control Specifications	Control Method	V/Hz inverter, Sensorless vector
	PWM Frequency	Adjustable 4, 8, 16 or 32kHz
	Speed Setting	0-10VDC, 0-20mA; digital (keypad)
	Accel/Decel	0-3000 seconds
	Velocity Loop Bandwidth	Adjustable to 180Hz (Control only)
	Current Loop Bandwidth	Adjustable to 1200Hz (Control only)
	Analog Output	0-10VDC or 10-0VDC @ 20mA max.; 4-20mA or 20-4mA
	Relay Output	30VDC@5A, 250VAC@6A

Appendix B

Parameter Tables

B.1 Parameters Sorted by Parameter Number

Table B-1 Parameters Sorted by Parameter Number

Param #	Access	Parameter Name	Description (Range)	Factory Setting	User Setting
P0-01	RO	Bipolar Analog Input Value	-100 to 100	Read Only	
P0-02	RO	2nd Analog Input Value	0 to 100	Read Only	
P0-03	RO	Post Ramp Speed Reference	-500 to 500	Read Only	
P0-04	RO	Digital Speed Reference	-P1-06 to P1-06	Read Only	
P0-05	RO	Torque Controller Reference	0 to 200	Read Only	
P0-06	RO	PID Reference	0 to 100	Read Only	
P0-07	RO	PID Feedback	0 to 100	Read Only	
P0-08	RO	PID Error	0 to 100	Read Only	
P0-09	RO	PID P Term	0 to 100	Read Only	
P0-10	RO	PID I Term	0 to 100	Read Only	
P0-11	RO	PID D Term	0 to 100	Read Only	
P0-12	RO	PID Output	0 to 100	Read Only	
P0-13	RO	Output Torque	0 to 200	Read Only	
P0-14	RO	Magnetizing Current	Drive dependent	Read Only	
P0-15	RO	Rotor Current	Drive dependent	Read Only	
P0-16	RO	Field Strength	0 to 100	Read Only	
P0-17	RO	Stator Resistance	Drive dependent	Read Only	
P0-18	RO	Stator Inductance	Drive dependent	Read Only	
P0-19	RO	Rotor Resistance	Drive dependent	Read Only	
P0-20	RO	DC Bus Voltage	0 to 1000	Read Only	
P0-21	RO	Drive Temperature	0 to 120	Read Only	
P0-22	RO	Supply Voltage L1 – L2	Drive dependent	Read Only	
P0-23	RO	Supply Voltage L2 – L3	Drive dependent	Read Only	
P0-24	RO	Supply Voltage L3 – L1	Drive dependent	Read Only	
P0-25	RO	Estimated Rotor Speed	Drive dependent	Read Only	

Table B-1 Parameters Sorted by Parameter Number (Cont.)

Param #	Access	Parameter Name	Description (Range)	Factory Setting	User Setting
P0-26	RO	kWh Meter	0 to 999.9	Read Only	
P0-27	RO	MWh Meter	0 to 60,000	Read Only	
P0-28	RO	Software ID – IO Processor	Drive dependent	Read Only	
P0-29	RO	Software ID – Motor Control	Drive dependent	Read Only	
P0-30	RO	Drive Serial Number	Drive dependent	Read Only	
P0-31	RO	Drive Serial Number #2		Read Only	
P0-32	RO	DSP Bootloader Version	E.g. “ 1.00”	Read Only	
P0-33	RO	Measured Cos phi	E.g. 0.78	Read Only	
P0-34	RO	Comms Error Count (DSP)	0 ... 65535	Read Only	
P0-35	RO	Configuration Register Value	Internal value	Read Only	
P0-36	RO	Digital Input Status	Internal value	Read Only	
P0-37	RO	Analog Out Internal Value	Internal value	Read Only	
P0-38	RO	Current Phase U Offset	Internal value	Read Only	
P0-39	RO	Current Phase U Ref	Internal value	Read Only	
P0-40	RO	Current Phase V Offset	Internal value	Read Only	
P0-41	RO	Current Phase V Ref	Internal value	Read Only	
P0-42	RO	Brake Resistor Max on Time	Time in milliseconds	Read Only	
P0-43	RO	Brake Resistor Duty Cycle	Internal value	Read Only	
P0-44	RO	Uq Internal Ref Value	Internal value	Read Only	
P0-45	RO	Ud Internal Ref Value	Internal value	Read Only	
P0-46	RO	Measured Spin Start Speed	Internal value	Read Only	
P0-47	RO	Calculated Slip Speed Value	Internal value (V/F mode only)	Read Only	
P0-48	RO	Hoist Boost Speed	Internal value	Read Only	
P0-49	RO	Rated Iq Internal Value	Internal value	Read Only	
P0-50	RO	Motor Voltage	V ph-ph (rms)	Read Only	
P0-51	RO	Switching Frequency Internal	Internal value	Read Only	

Table B-1 Parameters Sorted by Parameter Number (Cont.)

Param #	Access	Parameter Name	Description (Range)	Factory Setting	User Setting
P0-52	RO	Speed Hysteresis Value	Internal value	Read Only	
P0-53	RO	PID DC Bus Feedback Value	0..4096	Read Only	
P0-54	RO	Modbus Comms Error	0 ... 65535	Read Only	
P0-55	RO	Modbus Speed Reference	Internal value	Read Only	
P0-56	RO	Droop Speed	Internal value	Read Only	
P0-57	RO	Encoder Speed	-P1-06 to P1-06	Read Only	
P0-58	RO	Speed Jump Zone	Internal value	Read Only	
P0-59	RO	Modbus Write Command Data Value	Register dependent	Read Only	
P0-60	RO	Motor Control Loop ID	0 ... 65535	Read Only	
P1-01	RW	Motor Rated Voltage	0, 20 to 600	575	
P1-02	RW	Motor Rated Current	25% -100% of drive rated current	Drive rating	
P1-03	RW	Motor Rated Frequency	25Hz to 2000Hz	60	
P1-04	RW	Motor Rated Speed	0 to 60000 rpm	0	
P1-05	RW	Minimum Frequency / Speed	0.0 to P1-06	0.0	
P1-06	RW	Maximum Frequency / Speed	P1-05 to 5*P1-03 (max 2000Hz)	60.0	
P1-07	RW	Terminal / Keypad / PID Drive Control Mode Selection	0: Terminal Control 1: Keypad Control – fwd only 2: Keypad Control – fwd and rev 3: PID Control 4: Modbus RTU Control	0	
P1-08	RW	Digital Input Function Select	0 to 22	0	
P1-09	RW	Stop Mode Select	0: Ramp to Stop 1: Coast to Stop 2: Ramp to Stop with 'Fast Stop'	0	
P1-10	RW	Acceleration Ramp Time	0.0 to 3000.0	5.0	
P1-11	RW	Deceleration Ramp Time	0.0 to 3000.0	5.0	
P1-12	RW	Energy Optimizer	0: Disabled 1: Enabled	0	
P1-13	RO	Trip Log	Last four trips stored	Read only	
P1-14	RW	Extended Menu Access	Code 0 to 30000	0	
P2-01	RW	Preset Speed 1	-P1-06 to P1-06	50.0 (60.0)	
P2-02	RW	Preset Speed 2	-P1-06 to P1-06	0.0	
P2-03	RW	Preset Speed 3	-P1-06 to P1-06	0.0	
P2-04	RW	Preset Speed 4	-P1-06 to P1-06	0.0	
P2-05	RW	Preset Speed 5	-P1-06 to P1-06	0.0	
P2-06	RW	Preset Speed 6	-P1-06 to P1-06	0.0	
P2-07	RW	Preset Speed 7	-P1-06 to P1-06	0.0	
P2-08	RW	Preset Speed 8	-P1-06 to P1-06	0.0	
P2-09	RW	Skip Frequency	P1-05 to P1-06	0.0	

Table B-1 Parameters Sorted by Parameter Number (Cont.)

Param #	Access	Parameter Name	Description (Range)	Factory Setting	User Setting
P2-10	RW	Skip Frequency Band	0 to P1-06	0.0	
P2-11	RW	Analog Output / Digital Output 1 Function Select	Digital Output Mode 0: Drive Enabled 1: Drive Healthy 2: Motor at Target Speed 3: Motor Speed >0 4: Motor Speed >= Limit 5: Motor Torque >= Limit 6: 2nd Analog Input >= Limit Analog Output Mode 7: Motor Speed 8: Motor Torque 9: Motor Power 10: Motor Current	7	
P2-12h	RW	Digital Output Control High Limit	0.0 to 200.0	100.0	
P2-12L	RW	Digital Output Control Low Limit	0.0 to P2-12h	100.0	
P2-13	RW	User Relay Output Function Select	0: Drive Enabled 1: Drive Healthy 2: Motor at Target Speed 3: Motor Speed >0 4: Motor Speed >= Limit 5: Motor Torque >= Limit 6: 2nd Analog Input >= Limit	1	
P2-14h	RW	Relay Output Control High Limit	0.0 to 200.0	100.0	
P2-14L	RW	Relay Output Control Low Limit	0.0 to P2-14h	100.0	
P2-15	RW	Relay Output Mode	0: Normally Open 1: Normally Closed	0	
P2-16	RW	Zero Speed Holding Time	0.0 to 60.0	0.2	
P2-17	RW	Start Mode Select	Edge-r Auto-0 Auto-1 to 5	Auto-0	
P2-18	RW	Spin Start Enable	0: Disabled 1: Enabled	0	
P2-19	RW	Keypad Restart Mode	0: Minimum Speed, Edge-r 1: Previous Speed, Edge-r 2: Minimum Speed, Auto-r 3: Previous Speed, Auto-r	1	
P2-20	RW	Standby Mode	0.0 : Disabled 0.1 to 60.0	0.0	
P2-21	RW	Display Scaling Factor	0.000 to 30.000	0.000	
P2-22	RW	Display Scaling Source	0: 2nd Analog Input 1: Motor Speed 2: Motor Torque 3: Motor Current	0	
P2-23	RW	Brake Circuit Enable	0: Disabled 1: Enabled, Low Duty 2: Enabled, High Duty 3: Enabled, No Protection	0	
P2-24	RW	Effective Switching Frequency	4 to 16 / 24 / 32 / Auto Drive Power Rating Dependent	16 8 4	
P2-25	RW	2nd Deceleration Ramp time	0.0 to 3000.0	0.0	
P2-26	RW	Modbus Communication Baud Rate	t9.6, t19.2, t38.4, t57.6, t115.2 r9.6, r19.2, r38.4, r57.6, r115.2	t115.2	

Table B-1 Parameters Sorted by Parameter Number (Cont.)

Param #	Access	Parameter Name	Description (Range)	Factory Setting	User Setting
P2-27	RW	Drive Communication Address	0: Disabled 1 to 63	1	
P2-28	RW	Master / Slave Select	0: Slave Mode 1: Master Mode	0	
P2-29	RW	Master / Slave Speed Reference Scaling Factor	0 to 500.0	100.0	
P2-30	RW	Bipolar Analog Input Format	U 0-24 = 0 - 24VDC U 0-10 = 0 - 10VDC -10 -10 = -10 to + 10VDC -24 -24 = -24 to + 24VDC	U 0-24	
P2-31	RW	Bipolar Analog Input Scaling	0.0 to 500.0	100.0	
P2-32	RW	Bipolar Analog Input Offset	-500.0 to 500.0	0.0	
P2-33	RW	2nd Analog Input Format	d 0-24 = Digital U 0-10 = 0 to 10VDC A 4-20 = 4 to 20mA A 0-20 = 0 to 20mA	d 0-24	
P2-34	RW	2nd Analog Input Scaling	0 to 500.0	100.0	
P2-35	RW	Digital Speed Reference Scaling Control	0: Disabled (No Scaling) 1: Scaled by P2-29 2: Scaled by P2-29, bipolar analog input added as an offset 3: Scaled by P2-29 and by bipolar analog input	0	
P2-36	RW	Analog Output Format	U 0-10 = 0 to 10V A 4-20 = 4 to 20mA U 10-0 = 10 to 0V A 20-4 = 20 to 4mA	U 0-10	
P2-37	RW	Extended Menu Access Code	0 to 9999	101	
P2-38	RW	Parameter Lock	0 : Unlocked 1 : Locked	0	
P2-39	RO	Hours Run Counter	0 to 99999	Read Only	
P2-40	RO	Drive Type / Rating	-	Read Only	
P3-01	RW	Proportional Gain	0.1 to 30.0	2.0	
P3-02	RW	Integral Time Constant	0.0 to 30.0	1.0	
P3-03	RW	Differential Time Constant	0.00 to 1.0	0.00	
P3-04	RW	PID Operating Mode	0: Direct 1: Inverse	0	
P3-05	RW	PID Set Point / Reference Select	0: Digital 1: Analog	0	
P3-06	RW	PID Digital Reference	0.0 to 100.0	0.0	
P3-07	RW	PID Controller High Limit	P3-08 to 100.0	100	
P3-08	RW	PID Controller Low Limit	0 to P3-07	0	
P3-09	RW	User PID Output Limit / Function Control	0: Digital Output Limits 1: Analog Upper Limit 2: Analog Lower Limit 3: PID + Bipolar Analog Reference	0	
P3-10	RW	PID Feedback Source Select	0: 2nd Analog Input 1: Bipolar Analog Input	0	
P4-01	RW	Control Mode	0: Vector Speed Control 1: Vector Torque Control 2: V/F Speed Control	2	
P4-02	RW	Motor Parameter Auto Tune	0: Disabled 1: Enabled	0	

Table B-1 Parameters Sorted by Parameter Number (Cont.)

Param #	Access	Parameter Name	Description (Range)	Factory Setting	User Setting
P4-03	RW	Speed Controller Proportional Gain	1 to 4096	300	
P4-04	RW	Speed Controller Integral Time	0.010 to 1.000	0.050	
P4-05	RW	Motor Power Factor	0, 0.50 to 1.00	-	
P4-06	RW	Torque Reference Source Select	0: Preset Value 1: Bipolar Analog Input 2: 2nd Analog Input 3: Modbus RTU 4: Master / Slave	0	
P4-07	RW	Maximum Torque Limit / Torque Reference	0.0 to 200.0	200.0	
P4-08	RW	Minimum Torque Limit	0.0 to 150.0	0.0	
P4-09	RW	V/F Characteristic Adjustment Frequency	0 to P1-03	0.0	
P4-10	RW	V/F Characteristic Adjustment Voltage	0 to P1-01	0	
P5-01	RW	Motor Stator Resistance (Rs)	Drive dependent	-	
P5-02	RW	Motor Rotor Resistance (Rr)	Drive dependent	-	
P5-03	RW	Stator Inductance (Ls)	Drive dependent	-	
P5-04	RW	Magnetizing Current (Id rms)	10% to 80% of motor rated current	-	
P5-05	RW	Leakage Coefficient (Sigma)	0.025 to 0.250	-	
P5-06	RW	Reserved		-	
P5-07	RW	Rs Measurement Enable	0: Disable 1: Enable	1	
P5-08	RW	Reserved		-	
P5-09	RW	Over Voltage Current Limit	0 to 100% of motor rated current	0	
P5-10	RW	Re-Generation Current Limit	0.0 to 200% of motor rated current	100.0	
P5-11	RW	Pulse Width Limitation	0..500 (Time = value *16.67ns)	-	
P5-12	RW	V/F Mode Magnetizing Period	0...2000ms	-	
P6-01	RW	Software Upgrade Enable	0: Disable 1: I/O En 2: DSP En	0	
P6-02	RW	Thermal Management Enable	0: Disable 1: Enable	0	
P6-03	RW	Auto-Reset Delay Time	1s...60	20	
P6-04	RW	User Relay Speed Hysteresis Band	0.0 ... 25.0	0.3	
P6-05	RW	Encoder Feedback Enable	0: Disabled 1: Enabled	0	
P6-06	RW	Encoder PPR	0 .. 10000	0	
P6-07	RW	Encoder Speed Error Limit	0.0 ... 50.0	5.0	
P6-08	RW	Modbus Communication Loss Timer	0: Disabled 1..60	2	
P6-09	RW	Speed Droop Control	0.0 ...25.0% of P1-03	0	
P6-10	RW	Brake Chopper Duty Cycle when Under Temperature	0.0...20.0	2.0	
P6-11	RW	Preset Speed Run Time On Enable	0.0..600.0	0.0	
P6-12	RW	Preset Speed Run Time on Disable	0.0..600.0	0.0	

Appendix C

CE Guidelines

C.1 CE Declaration of Conformity

Baldor indicates that the products are only components and not ready for immediate or instant use within the meaning of "Safety law of appliance", "EMC Law" or "Machine directive". The final mode of operation is defined only after installation into the user's equipment. It is the responsibility of the user to verify compliance.

C.2 EMC - Conformity and CE Marking

The information contained herein is for your guidance only and does not guarantee that the installation will meet the requirements of the council directive 89/336/EEC.

The purpose of the EEC directives is to state a minimum technical requirement common to all the member states within the European Union. In turn, these minimum technical requirements are intended to enhance the levels of safety both directly and indirectly. Council directive 89/336/EEC relating to Electro Magnetic Compliance (EMC) indicates that it is the responsibility of the system integrator to ensure that the entire system complies with all relative directives at the time of installing into service.

Motors and controls are used as components of a system, per the EMC directive. Hence all components, installation of the components, interconnection between components, and shielding and grounding of the system as a whole determines EMC compliance.

The CE mark does not inform the purchaser which directive the product complies with. It rests upon the manufacturer or his authorized representative to ensure the item in question complies fully with all the relative directives in force at the time of installing into service, in the same way as the system integrator previously mentioned. Remember, it is the instructions of installation and use, coupled with the product, that comply with the directive.

Note that this drive is commercial in design; not for residential environments.

Wiring of Shielded (Screened) Cables

Figure C-1

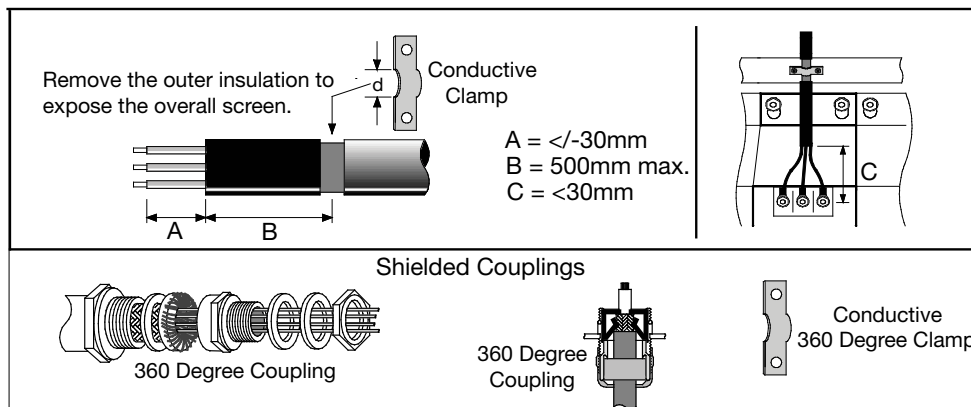

C.3 EMC Installation Options

When installed for Class A or Class B operation, the control is compliant with EN55011 (1991)/ EN55022 (1994) for radiated emissions as described.

C.4 Grounding for Wall Mounting (Class A) also see Chapters 4 and 5

Top cover must be installed.

- A single-star point (earth) is required.
- The protective earth connection (PE) to the motor must be run inside the screened cable or conduit between the motor and control and be connected to the protective earth terminal at the control.
- The internal/external AC supply filter must be permanently earthed.
- The signal/control cables must be screened.

C.5 Grounding for Enclosure Mounting (Class B) also see Chapters 4 and 5

- The unit is installed for Class B operation when mounted inside an enclosure that has 10dB attenuation from 30 to 100MHz (typically the attenuation provided by a metal cabinet with no opening greater than 0.15m), using the recommended AC supply filter and having met all cable requirements.

Note: Radiated magnetic and electric fields inside the cubicle will be high and components installed inside must be sufficiently immune.

- The control, external filter and associated equipment are mounted onto a conducting, metal panel. Do not use enclosures that use insulating mounting panels or undefined mounting structures. Cables between the control and motor must be screened or in conduit and terminated at the control.

C.6 Using CE approved components will not guarantee a CE compliant system!

1. The components used in the drive, installation methods used, materials selected for interconnection of components are important.
2. The installation methods, interconnection materials, shielding, filtering and grounding of the system as a whole will determine CE compliance.
3. The responsibility of CE mark compliance rests entirely with the party who offers the end system for sale (such as an OEM or system integrator).

Baldor products which meet the EMC directive requirements are indicated with a “CE” mark. A signed CE declaration of conformity is provided in this section.

C.7 EMC Wiring Technique

Figure C-2

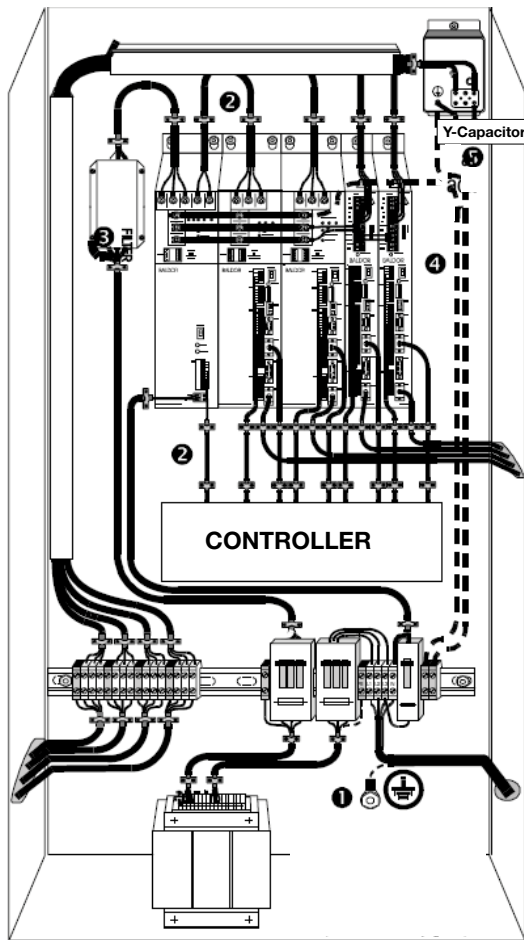

1 CABINET

The drawing shows an electroplated zinc coated enclosure, which is connected to ground.

This enclosure has the following advantages:

- All parts mounted on the back plane are connected to ground.
 - All shield (screen) connections are connected to ground.
- Within the cabinet there should be a spatial separation between power wiring (motor and AC power cables) and control wiring.

2 SCREEN CONNECTIONS

All connections between components must use shielded cables. The cable shields must be connected to the enclosure. Use conductive clamps to ensure good ground connection. With this technique, a good ground shield can be achieved.

3 EMC - FILTER

The EMI or main filter should be mounted next to the power supply (here BPS). For the connection to and from the main filter, screened cables should be used. The cable screens should be connected to screen clamps on both sides. (Exception: Analog Command Signal).

4 GROUNDING (EARTH)

For safety reasons (VDE0160), all Baldor components must be connected to ground with a separate wire. The diameter of the wire must be at minimum AWG#6 (10mm²). Ground connections (dashed lines) must be made from the central ground to the regen resistor enclosure and from the central ground to the Shared Power Supply.

5 Y-CAPACITOR

The connection of the regeneration resistor can cause RFI (radio frequency interference) to be very high. To minimize RFI, a Y-capacitor is used. The capacitor should only be connected between the dynamic brake resistor housing and terminal pin R1.

Attention: The drawing shows only the principle of an EMC wiring. The installation shown can be different to any national standard (e.g. VDE).

C.8 EMC Installation Instructions

To ensure electromagnetic compatibility (EMC), the following installation instructions should be completed. These steps help to reduce interference.

Consider the following:

- Grounding of all system elements to a central ground point
- Shielding of all cables and signal wires
- Filtering of power lines

A proper enclosure should have the following characteristics:

- A) All metal conducting parts of the enclosure must be electrically connected to the back plane. These connections should be made with a grounding strap from each element to a central grounding point. [1]
- B) Keep the power wiring (motor and power cable) and control wiring separated. If these wires must cross, be sure they cross at 90 degrees to minimize noise due to induction.
- C) The shield connections of the signal and power cables should be connected to the screen rails or clamps. The screen rails or clamps should be conductive clamps fastened to the cabinet. [2]
- D) The cable to the regeneration resistor must be shielded. The shield must be connected to ground at both ends.
- E) The location of the AC mains filter has to be situated close to the drive so the AC power wires are as short as possible.
- F) Wires inside the enclosure should be placed as close as possible to conducting metal, cabinet walls and plates. It is advised to terminate unused wires to chassis ground. [1]
- G) To reduce ground current, use at least a 10mm² (6 AWG) solid wire for ground connections.

[1] Grounding in general describes all metal parts which can be connected to a protective conductor, e.g. housing of cabinet, motor housing, etc. to a central ground point. This central ground point is then connected to the main plant (or building) ground.

[2] Or run as twisted pair at minimum.

Example Cable Screens Grounding

Figure C-3

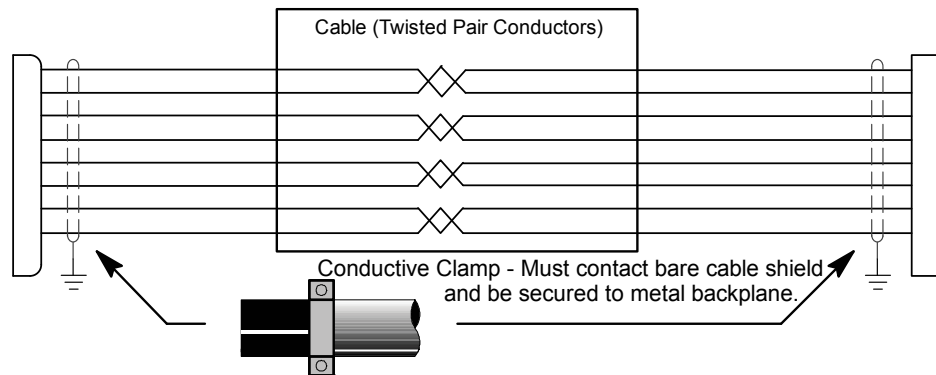

Appendix D

Options and Kits

D.1 Accessories

The VS1STS Remote Keypad can be panel mounted for remote control or display of the drive. The remote keypad comes with a standard 3.0 meter cable.

Table D-1 Remote Keypad

Catalog Number	Description
VS1STS-RKEY3	VS1STS and VS1MXS Remote Keypad with 3m cable

Optional Cables for VS1STS

Option cable assemblies for setting up and connecting a simple serial network.

Table D-2 Option Cables

Catalog Number	Description
VS1STS-J11SP	RJ11 Cable Splitter
VS1STS-USBPC	RS485 to USB Cable
VS1STS-CBL0P3	0.3m RJ11 Cable
VS1STS-CBL1	1m RJ11 Cable
VS1STS-CBL3	3m RJ11 Cable

Option Cards for VS1STS

Provides additional relay outputs for signal and control.

Table D-3 Option Cards

Catalog Number	Description
VS1ST-2ROUT	Provides one additional relay output for the drive
VS1ST-3ROUT	Provides 2 relays for drive running & drive tripped indicators

VS1STS Field Bus Gateways

Connects the VS1STS Modbus RTU RS485 communication interface to the field bus gateway.

Table D-4 Field Bus Gateways

Catalog Number	Description
VS1ST-PBUS	Profibus Gateway
VS1ST-DNET	DeviceNet Gateway
VS1ST-ENET	Ethernet Gateway

Appendix E

RS485/MODBUS Protocol

E.1 Introduction

The VS1STS AC Drive is supplied with imbedded RS485 communications that supports the Modbus-RTU protocol. This allows the user to set up a multi-drop communications network between multiple VS1STS drives and a PLC or host computer without the requirement of option boards for the drives. This is a master-slave architecture where the master (e.g. PLC) can monitor and control multiple VS1STS drives on the same network with other Modbus-RTU slaves. This appendix defines the specifics needed to set up a VS1STS on an RS485 network running the Modbus-RTU protocol and documents the function codes and exception codes supported by the VS1STS. For a complete definition of the Modbus-RTU protocol and the content of specific messages see www.modbus.org.

E.2 Installation

1. Connect the RS485 communication line to RJ11 connector, (see Chapter 5).
2. Check the connections and turn ON the inverter.
3. Table E-1 documents the parameters within the VS1STS that are related to communications:

Table E-1 Communication Parameters

Number	Name	Comments
P1-07	Start/Stop Source	Set to 4 for applications that require network control to start and stop the drive over the network
P2-26	Baud Rate	Select the baud rate utilized by the master device on the network. All devices on the network must utilize the same baud rate.
P2-27	Drive Address	Set to the desired Modbus-RTU address (note that each device on the network must have a unique address).
P2-28	Master/Follower	Select drive to be the master line reference or a follower section.
P2-29	Follower Reference Scale Factor	Set a percentage scale factor for the follower drive to proportionally run faster or slower than the master reference.

4. Make connection to the master and other slave devices. The maximum number of drives that can be connected is 31. Maximum length of communication line is 2300 ft (700m).

E.3 Operation

1. Remove all power from the VS1STS control.
2. Disconnect the motor load from the control (terminals U, V and W). (Do not connect the motor load until stable communication between the master controller and the inverter are verified.)
3. Verify master controller and the inverter connections.
4. Turn ON the inverter.
5. Start the communications program on the master controller.
6. Verify proper communications and that the VS1STS is controlled as desired.
7. Remove all power from the VS1STS control.
8. Connect the motor load to the control (terminals U, V and W).
9. Turn ON the inverter.
10. Verify proper operation. See Troubleshooting at the end of this section to aid in resolving any remaining problems.

E.4 Performance Specifications

Table E-2 Communication Performance

Communication Method	RS485 Hardware specification, MODBUS protocol
Transmission Form	Bus method, Multi drop Master/Slave architecture
Applicable inverter	VS1STS series
Connectable drives	Max 31
Transmission distance	Max. 2,300 ft (Repeater may be required for high noise environments.)

E.5 Hardware Specifications

Table E-3 Communication Hardware

Installation	Use RJ11 connector on control (see chapter 5)
Power Supply	Provided by isolated power from the inverter power supply

E.6 Communication Specifications

Table E-4 Communication Specifications

Communication Speed	115200 bps (default), 57600, 38400, 19200, 9600
Error Check	CRC
Data Format	1 start bit, 8 data bits, 1 stop bits, no parity
Physical Signal	RS 485 (2 wire)
User Interface	RJ11
Protocol	Modbus RTU

E.7 Communications Protocol (MODBUS-RTU)

The VS1STS supports Master / Follower Modbus RTU communications, using the 03 Read Holding Registers and 06 Write Single Holding Register commands. Many Master devices treat the first Register address as Register 0, therefore it may be necessary to convert the Register Numbers detail in section 0 by subtracting 1 to obtain the correct Register address. The telegram structure is as follows:

Table E-5 Command 03 – Read Holding Registers

Master Telegram	Length		Follower Response	Length
Follower Address	1 Byte		Follower Address	1 Byte
Function Code (03)	1 Byte		Starting Address	1 Byte
1st Register Address	2 Byte		1st Register Value	2 Bytes
No. Of Registers	2 Byte		2nd Register Value	2 Bytes
CRC Checksum	2 Byte		Etc.	2 Bytes
			CRC Checksum	2 Bytes

Table E-6 Command 06 – Write Single Holding Register

Master Telegram	Length		Follower Response	Length
Follower Address	1 Byte		Follower Address	1 Byte
Function Code (06)	1 Byte		Function Code (06)	1 Byte
Register Address	2 Byte		Register Address	2 Bytes
Value	2 Byte		Register Value	2 Bytes
CRC Checksum	2 Byte		CRC Checksum	2 Bytes

E.8 Modbus Register Map

Table E-7

Reg. No.	Par.	Type	Supported Commands	Function		Range	Explanation
				Low Byte	High Byte		
1	-	R/W	03,06	Drive Control Command		0..3	16 Bit Word. Bit 0: Low = Stop High = Run Enable Bit 1: Low = No Function, High = Fault Reset Bit 2: Low = Decel Ramp 1 (P1-11), High = Decel Ramp 2
2	-	R/W	03,06	Modbus Speed Reference Setpoint		0..20000	Setpoint frequency x 10, e.g. 100 = 10.0Hz
3	-	R/W	03,06	Torque Reference		0..2000	Torque Setpoint % x 10, e.g. 1000 = 100.0%
4	-	R/W	03,06	Acceleration and Deceleration Time		0..255	Ramp time in seconds x 10, e.g. 250 = 25 seconds
5	-	R	03	Reserved			
6	-	R	03	Error Code	Drive Status		Low Byte = Drive Error Code, see table below High Byte = Drive Status as follows: 0: Drive Stopped 1: Drive Running 2: Drive Tripped
7		R	03	Output Motor Frequency		0..20000	Output frequency in Hz x 10, e.g. 100 = 10.0Hz
8		R	03	Output Motor Current		0..6000	Output Motor Current in Amps x 10, e.g. 10 = 1.0 Amps
9	P0-13	R	03	Output Motor Torque		0..2000	Output Motor Torque % x 10, e.g. 1000 = 100.0%
10		R	03	Output Motor Power		0..3200	Output Motor Power in kW x 10, e.g. 100 = 10.0kW
11	-	R	03	Digital Input Status		0..15	Indicates the status of the 4 digital inputs, Lowest Bit = 1 Input 1
21	P0-01	R	03	Bipolar Analog Input Value		0..1000	Analog input % of full scale x 10, e.g. 1000 = 100%
22	P0-02	R	03	2nd Analog Input Value		0..1000	Analog input % of full scale x 10, e.g. 1000 = 100%
40	P0-20	R	03	DC Bus Voltage		0..1000	DC Bus Voltage in Volts
41	P0-21	R	03	Drive Temperature		0..100	Drive heatsink temperature in °C
42	P0-22	R	03	Supply Voltage L1		0..660	L1 – L2 Supply Voltage
43	P0-23	R	03	Supply Voltage L2		0..660	L2 – L3 Supply Voltage
44	P0-24	R	03	Supply Voltage L3		0..660	L3 – L1 Supply Voltage
45	P0-25	R	03	Estimated Rotor Speed			Internal Speed Value
46	P0-26	R	03	kWh Meter		0..1000	Energy consumed in kWh
47	P0-27	R	03	MWh Meter		0..65535	Energy consumed in MWh

Baldor Sales Offices

UNITED STATES

ARIZONA

PHOENIX

4211 S 43RD PLACE
PHOENIX, AZ 85040
PHONE: 602-470-0407
FAX: 602-470-0464

ARKANSAS

CLARKSVILLE

1001 COLLEGE AVENUE
CLARKSVILLE, AR 72830
PHONE: 479-754-9108
FAX: 479-754-9205

CALIFORNIA

LOS ANGELES

6480 FLOTILLA STREET
COMMERCE, CA 90040
PHONE: 323-724-6771
FAX: 323-721-5859

HAYWARD

21056 FORBES AVENUE
HAYWARD, CA 94545
PHONE: 510-785-9900
FAX: 510-785-9910

COLORADO

DENVER

3855 FOREST STREET
DENVER, CO 80207
PHONE: 303-623-0127
FAX: 303-595-3772

CONNECTICUT

WALLINGFORD

65 SOUTH TURNPIKE ROAD
WALLINGFORD, CT 06492
PHONE: 203-269-1354
FAX: 203-269-5485

FLORIDA

TAMPA/PUERTO RICO/ VIRGIN ISLANDS

3906 EAST 11TH AVENUE
TAMPA, FL 33605
PHONE: 813-248-5078
FAX: 813-247-2984

GEORGIA

ATLANTA

62 TECHNOLOGY DRIVE
ALPHARETTA, GA 30005
PHONE: 770-772-7000
FAX: 770-772-7200

ILLINOIS

CHICAGO

340 REMINGTON BLVD.
BOLINGBROOK, IL 60440
PHONE: 630-296-1400
FAX: 630-226-9420

INDIANA

INDIANAPOLIS

5525 W. MINNESOTA STREET
INDIANAPOLIS, IN 46241
PHONE: 317-246-5100
FAX: 317-246-5110

IOWA

DES MOINES

1800 DIXON STREET, SUITE C
DES MOINES, IA 50316
PHONE: 515-263-6929
FAX: 515-263-6515

MARYLAND

BALTIMORE

6660 SANTA BARBARA RD.
SUITES 22-24
ELKRIDGE, MD 21075
PHONE: 410-579-2135
FAX: 410-579-2677

MASSACHUSETTS

BOSTON

6 PULLMAN STREET
WORCESTER, MA 01606
PHONE: 508-854-0708
FAX: 508-854-0291

MICHIGAN

DETROIT

5993 PROGRESS DRIVE
STERLING HEIGHTS, MI 48312
PHONE: 586-978-9800
FAX: 586-978-9969

MINNESOTA

MINNEAPOLIS

21080 134TH AVENUE NORTH
ROGERS, MN 55374
PHONE: 763-428-3633
FAX: 763-428-4551

MISSOURI

ST LOUIS

13678 LAKEFRONT DRIVE
EARTH CITY, MO 63045
PHONE: 314-373-3032
FAX: 314-373-3038

KANSAS CITY

1501 BEDFORD AVENUE
NORTH KANSAS CITY, MO 64116
PHONE: 816-587-0272
FAX: 816-587-3735

NEW YORK

AUBURN

ONE ELLIS DRIVE
AUBURN, NY 13021
PHONE: 315-255-3403
FAX: 315-253-9923

NORTH CAROLINA

GREENSBORO

1220 ROTHERWOOD ROAD
GREENSBORO, NC 27406
PHONE: 336-272-6104
FAX: 336-273-6628

OHIO

CINCINNATI

2929 CRESCENTVILLE ROAD
WEST CHESTER, OH 45069
PHONE: 513-771-2600
FAX: 513-772-2219

CLEVELAND

8929 FREEWAY DRIVE
MACEDONIA, OH 44056
PHONE: 330-468-4777
FAX: 330-468-4778

OKLAHOMA

TULSA

7170 S. BRADEN, SUITE 140
TULSA, OK 74136
PHONE: 918-366-9320
FAX: 918-366-9338

OREGON

PORTLAND

20393 SW AVERY COURT
TUALATIN, OR 97062
PHONE: 503-691-9010
FAX: 503-691-9012

PENNSYLVANIA

PHILADELPHIA

1035 THOMAS BUSCH
MEMORIAL HIGHWAY
PENNSAUKEN, NJ 08110
PHONE: 856-661-1442
FAX: 856-663-6363

PITTSBURGH

159 PROMINENCE DRIVE
NEW KENSINGTON, PA 15068
PHONE: 724-889-0092
FAX: 724-889-0094

TENNESSEE

MEMPHIS

4000 WINCHESTER ROAD
MEMPHIS, TN 38118
PHONE: 901-365-2020
FAX: 901-365-3914

TEXAS

DALLAS

2920 114TH STREET SUITE 100
GRAND PRAIRIE, TX 75050
PHONE: 214-634-7271
FAX: 214-634-8874

HOUSTON

10355 W. LITTLE YORK ROAD
SUITE 300
HOUSTON, TX 77041
PHONE: 281-977-6500
FAX: 281-977-6510

UTAH

SALT LAKE CITY

2230 SOUTH MAIN STREET
SALT LAKE CITY, UT 84115
PHONE: 801-832-0127
FAX: 801-832-8911

WISCONSIN

MILWAUKEE

1960 SOUTH CALHOUN ROAD
NEW BERLIN, WI 53151
PHONE: 262-784-5940
FAX: 262-784-1215

INTERNATIONAL SALES

FORT SMITH, AR

P.O. BOX 2400
FORT SMITH, AR 72902
PHONE: 479-646-4711
FAX: 479-648-5895

CANADA

EDMONTON, ALBERTA

4053-92 STREET
EDMONTON, ALBERTA T6E 6R8
PHONE: 780-434-4900
FAX: 780-438-2600

TORONTO

OAKVILLE, ONTARIO

2750 COVENTRY ROAD
OAKVILLE, ONTARIO L6H 6R1
PHONE: 905-829-3301
FAX: 905-829-3302

MONTREAL, QUEBEC

5155 J-ARMAND BOMBARDIER
SAINT-HUBERT, QUÉBEC
CANADA J3Z 1G4
PHONE: 514-933-2711
FAX: 514-933-8639

VANCOUVER,

BRITISH COLUMBIA

1538 KEBET WAY
PORT COQUITLAM,
BRITISH COLUMBIA V3C 5M5
PHONE 604-421-2822
FAX: 604-421-3113

WINNIPEG, MANITOBA

54 PRINCESS STREET
WINNIPEG, MANITOBA R3B 1K2
PHONE: 204-942-5205
FAX: 204-956-4251

AUSTRALIA

UNIT 3, 6 STANTON ROAD
SEVEN HILLS, NSW 2147, AUSTRALIA
PHONE: (61) (2) 9674 5455
FAX: (61) (2) 9674 2495

UNIT 8, 5 KELLETTS ROAD

ROWVILLE, VICTORIA, 3178 AUSTRALIA
PHONE: (61) (3) 9753 4355
FAX: (61) (3) 9753 4366

EL SALVADOR

RESIDENCIAL PINARES DE SUIZA
POL. 15 #44,
NVA. SAN SALVADOR, EL SALVADOR
PHONE: +503 2288-1519
FAX: +503 2288-1518

CHILE

LUIS THAYER OJEDA 166,
OF 402 - PROVIDENCIA
SANTIAGO, CHILE
PHONE: +56 2 964-3210

CHINA

160 SONG SHENG ROAD
SONGJIANG INDUSTRY ZONE
SHANGHAI 201613, CHINA
PHONE: +86 21 5760 5335
FAX : +86 21 5760 5336

GERMANY

HERMANN-HEINRICH-GOSSEN-STRASSE 3
KÖLN, D-50858 GERMANY
PHONE: +49 2234 37941-0
FAX: +49 2234 3794164

DIESELSTRASSE 22

KIRCHHEIM, D-85551
MUNICH, GERMANY
PHONE: +49 89 90508-0
FAX: +49 89 9050886

INDIA

OFFICE NO 517 & 518,
5TH FLOOR, SIDDHARTH TOWERS,
CTS NO. 421 (1), SURVEY NO 12,
KOTHRUD, PUNE 411 038,
MAHARASHTRA, INDIA
PHONE: + 91 20 25 45 27 17
FAX: + 91 20 25 45 27 19

INDONESIA

TALavera OFFICE PARK,
28TH FLOOR, SUITE M18
JI. T.B. SIMATUPANG, KAV. 22-26
CILANDAK, JAKARTA SELATAN, 12430
INDONESIA
PHONE: +62 21 75 999 879
FAX: + 62 21 75 999 878

ITALY

VIA SOTTOBISIO 30
CH-6828 BALERNA
SWITZERLAND
PHONE: +41 91 683 6161
FAX: +41 91 630 2633

JAPAN

DIA BLDG 802,
2-21-1 TSURUYA-CHO,
KANAGAWA-KU
YOKOHAMA, 221-0835, JAPAN
PHONE: 81-45-412-4506
FAX: 81-45-412-4507

KOREA

RM#1715, SUSEO TOWER, 725,
SUSEO-DONG, GANGNAM-GU,
SEOUL 135-757 KOREA
PHONE: (82) 2 2226 9369
FAX: (82) 2 2226 9368

MEXICO

LEON, GUANAJUATO

KM. 2.0 BLVD. AEROPUERTO
LEÓN 37545, GUANAJUATO, MÉXICO
PHONE: (82) 2 2226 9369
FAX: +52 477 761 2010

MIDDLE EAST & NORTH AFRICA

VSE INTERNATIONAL CORP.
3233 N ARLINGTON HEIGHTS ROAD
SUITE 100W
ARLINGTON HEIGHTS, IL 60004 USA
PHONE: 847 590 5547
FAX: 847 590 5587

PANAMA

AVE. RICARDO J. ALFARO
EDIFICIO SUN TOWERS MALL
PISO 2, LOCAL 55
CIUDAD DE PANAMÁ, PANAMÁ
PHONE: +507 236-5155
FAX: +507 236-0591

SINGAPORE

18 KAKI BUKIT ROAD 3, #03-09
ENTREPRENEUR BUSINESS CENTRE
SINGAPORE 415978
PHONE: (65) 6744 2572
FAX: (65) 6747 1708

SWITZERLAND

POST FACH 73
SCHUETZENSTRASSE 59
FEUERTHALEN, CH-8245
SWITZERLAND
PHONE: +41 52 647 4700
FAX: +41 52 659 2394

TAIWAN

1F, NO 126 WENSHAN 3RD STREET,
NANTUN DISTRICT,
TAICHUNG CITY 408
TAIWAN R.O.C
PHONE: (886) 4 238 04235
FAX: (886) 4 238 04463

UNITED KINGDOM

6 BRISTOL DISTRIBUTION PARK
HAWKLEY DRIVE
BRISTOL BS32 0BF U.K.
PHONE: +44 1454 850000
FAX: +44 1454 859001

VENEZUELA

AV. ROMA. QTA EL MILAGRO. URB.
CALIFORNIA NORTE
CARACAS, 1070
VENEZUELA
PHONE/FAX: +58 212 272 7343
MOBILE: +58 414 114 8623



BALDOR[®]
A MEMBER OF THE ABB GROUP

P.O. Box 2400, Fort Smith, AR 72902-2400 U.S.A., Ph: (1) 479.646.4711, Fax (1) 479.648.5792, International Fax (1) 479.648.5895

Baldor - Dodge

6040 Ponders Court, Greenville, SC 29615-4617 U.S.A., Ph: (1) 864.297.4800, Fax: (1) 864.281.2433

www.baldor.com