



VIBE X2

USAGE INFORMATION
SUPPLEMENT TO LANZAR
SIGNAL PROCESSOR MANUAL

INTRODUCTION

FEATURES:

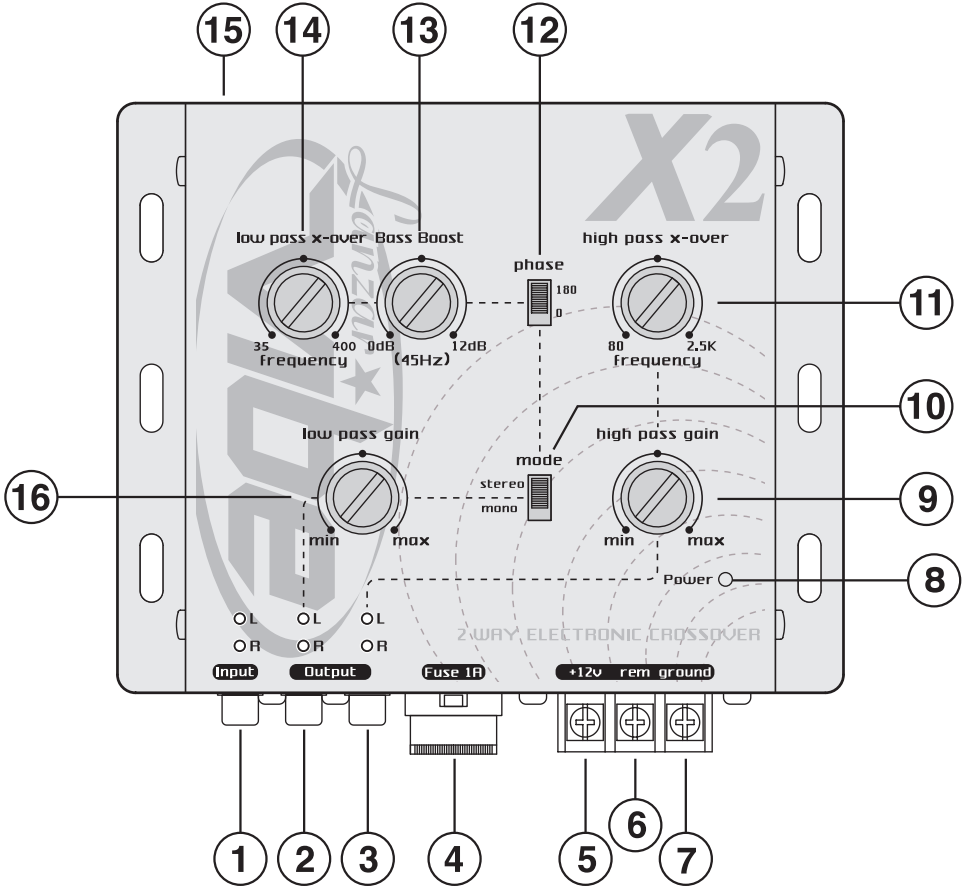

FUNCTIONS

1. SIGNAL INPUTS

To be connected to the output of the source unit.

2. LOW PASS SUBWOOFER OUTPUT TERMINALS

To be connected to the subwoofer channel amplifier left/right inputs.

3. HIGH PASS CHANNEL OUTPUT TERMINALS

To be connected to the channel amplifier left/right inputs.

4. FUSE

This crossover uses a 1-amp, blade-type fuses for protection from power surges or a short circuit.

5. POWER INPUT TERMINAL (12V)

To be connected to the positive terminal of your vehicle battery or other constant +12V source.

6. REMOTE TURN-ON INPUT TERMINAL (REMOTE)

To be connected to the remote control wire or antenna lead of the source unit for remote ON/OFF.

7. GROUND INPUT TERMINAL

To be wired to the vehicle's chassis ground.

8. POWER INDICATOR

This indicator lights up when the internal switching power supply is activated and the unit is operational.

FUNCTIONS

9. HIGH PASS GAIN CONTROL

For adjusting the channel output signal level.

10. SUBWOOFER STEREO/MONO SWITCH

For selection of stereo or mono mode subwoofer output.

11. HIGH-PASS FREQUENCY SELECTOR

For selection of high-pass crossover frequency between 80 Hz and 2.5KHz

12. PHASE INVERTER

Position the switch to the "180" position shifts the subwoofer output signals 180 degrees out-of-phase relative to the front and rear output signals.

13. BASS-BOOST LEVEL CONTROL (45Hz)

For increasing the Bass boost level up to +12dB.

14. LOW PASS SUBWOOFER FREQUENCY SELECTOR

For selection of the low-pass crossover frequency for the subwoofer channel between 35 Hz and 400 Hz.

15. SUBWOOFER OUTPUT LEVEL REMOTE CONTROL TERMINAL.

To be connected to the remote control for exclusive maneuver of the subwoofer output level, and the subwoofer output level control on the unit ("16" below) is bypassed.

16. LOW PASS SUBWOOFER OUTPUT GAIN CONTROL

For adjusting the subwoofer channel output signal level.

ELECTRICAL & AUDIO CONNECTIONS

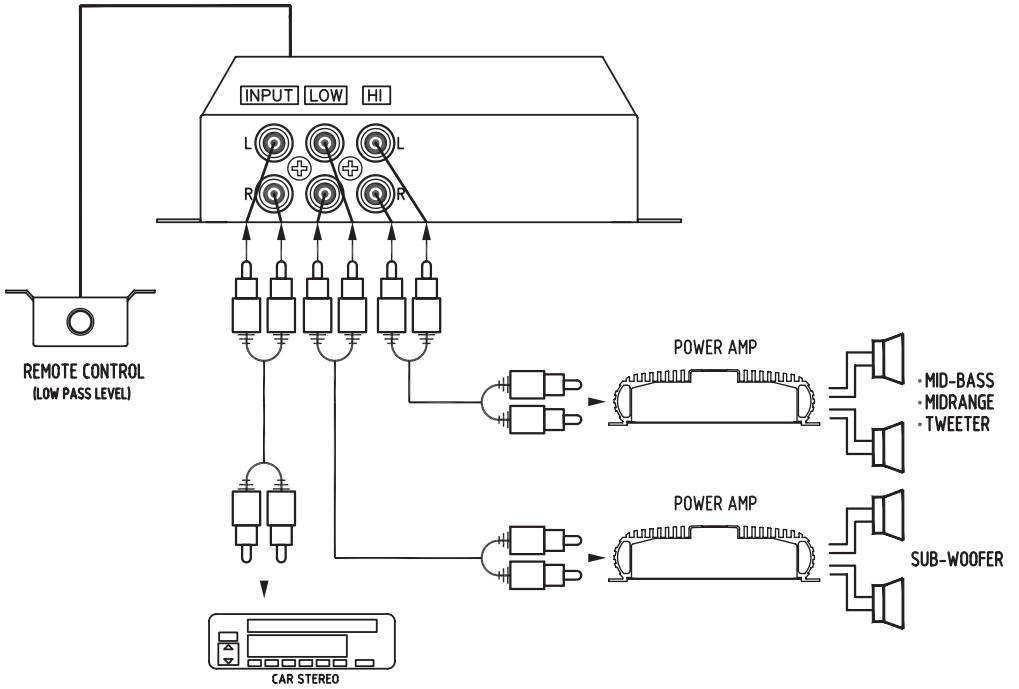

ELECTRICAL & AUDIO CONNECTIONS

Precautions

1. To prevent short circuits, be sure to disconnect the negative battery ground lead before wiring the system up.
2. When you finish the installation, be sure to make one more check to be sure everything is done correctly.
3. Reinstall all car parts that were removed.
4. Reconnect the negative battery ground lead.

Primary Wiring Descriptions

ELECTRICAL	PRIME CONNECTION	DESCRIPTION
12V	BATTERY +	Connect to the positive battery terminal (constant + 12V source)
GROUND	GROUND -	Connect to the vehicle's chassis ground (check for good ground)
REMOTE	REMOTE B+(12V)	Connect to the remote control wire (or the electrical antenna) of the car radio/cassette deck
INPUT	RADIO/TAPE PLAYER TO CROSSOVER MODULE	Connect from pre-amp output of radio/tape player (or CD) into
HIGH PASS OUTPUT	CROSSOVER MODULE TO ANY AMPLIFIER	Connect from "high-pass output" of CROSSOVER module to any amplifier input.
LOW PASS OUTPUT	CROSSOVER MODULE TO SUB-WOOFER AMPLIFIER	Connect from low-pass sub-woofer output of CROSSOVER to sub-woofer amplifier input.

NOISE CHECK & SYSTEM ADJUSTMENT

NOISE CHECK

Check the entire audio system for noise before permanently securing the CROSSOVER mounting

1. Start the engine.
2. Turn the audio system on.
3. Rev the engine and vary the VOLUME of the audio system to determine if there is any unwanted noise.

If so, turn both the audio system and the engine off. Do not secure the CROSSOVER mounting screws. Refer to the "Trouble Shooting Guide" at this manual.

4. If the audio system does not have any noise, securely tighten the CROSSOVER mounting screws and double check the wiring cables for safe placement.

SYSTEM ADJUSTMENT

Preliminary Adjustments

Pre-setting the system provides a necessary starting point for fine-tuning the entire audio system to maximum performance.

NOTE: DO NOT MOUNT CROSSOVER UNTIL THE FOLLOWING PROCEDURES HAVE BEEN COMPLETED.

1. Preset each amplifier input gain adjustment at the amplifier to half of maximum.
2. Before turning the audio system on, preset-adjust the high-pass and low-pass sub-woofer output level controls, as well as the high-pass and sub-woofer channel low-pass crossover points.
3. Slowly turn the volume up and listen carefully for: Obvious trouble in sound (distortion, no sound, no hiss, total silence). Turn the system off refer to "Trouble Shooting Guide" at this manual.

Caution

DO NOT ROUTE AUDIO CABLES AND POWER CABLES TOGETHER! THIS CAN CAUSE ENGINE NOISE IN YOUR AUDIO SYSTEM. ALWAYS DISCONNECT THE SYSTEM FROM THE BATTERY BEFORE ATTEMPTING TO MAKE OR ALTER ANY CONNECTIONS. THIS PRODUCT IS DESIRED FOR USE IN ANY 12 VOLTS NEGATIVE GROUND ELECTRICAL SYSTEM ONLY. INSTALLING THIS PRODUCT IN ANY POSITIVE GROUND ELECTRICAL SYSTEM COULD SERIOUSLY DAMAGE THE AUDIO SYSTEM.

TROUBLE SHOOTING GUIDE

PROBLEM	POSSIBLE CAUSE
1. There is an audible distortion at a low volume level.	Output levels NOT set correctly.
2. A whining sound can be heard through the speakers when the audio system is at low volume with the engine running. The whining noise remains unchanged or seems to disappear when the volume level is increased.	Check the red power wire. it must be connected directly to the battery. Check the system's ground point. it must make good contact with chassis ground (bare metal). The radio and the CROSSOVER must be grounded at the same reference point.
3. There is a "motorboating" type of sound when the engine is running and the audio system volume is set at a reasonably high level.	Check the red power wire, it must be connected directly to the battery. Check the system's ground point, it must make good contact with chassis ground (bare metal).

INSTALLATION

INSTALLATION

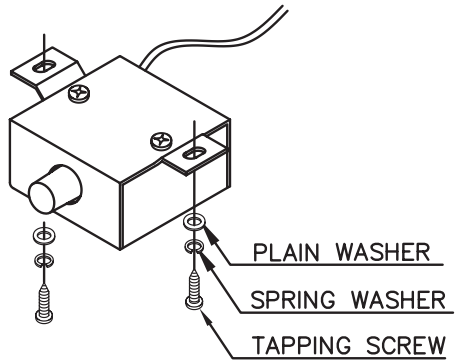
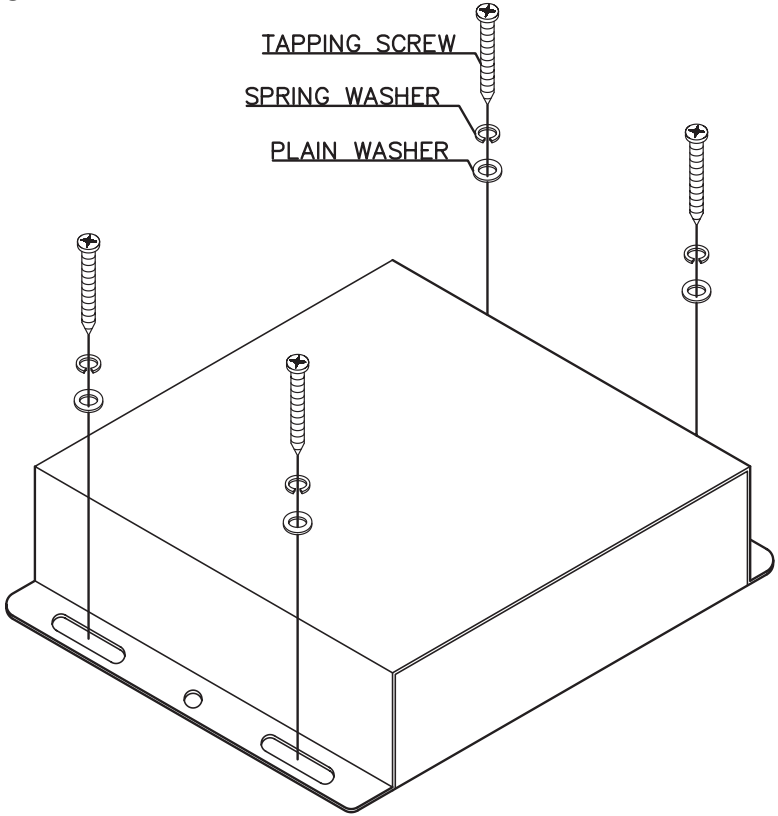

SPECIFICATIONS

SPECIFICATIONS

Power source:	14.4 volts DC negative ground
Input current	0.5 amp max
Distortion:	0.01% THD at 1 V output level
Frequency response:	10Hz-30KHz ± 3 dB
S/N ratio (A weighted):	>95dB
Separation:	60 dB
Crossover frequencies (continuously variable):	
Low-pass:	35-400 Hz
High-pass:	80-2.5KHz
Crossover slope rate:	12 dB per octave 2nd Order Butter worth
Subwoofer boost:	Single octave + 12dB at 45 Hz
Input impedance :	> 10K Ohms
Output impedance	<1K Ohms
Output voltage level:	5 volts max
Dimensions:	160mm (W) x 130mm (D) x 37mm (H)

FEATURES AND SPECIFICATIONS SUBJECT TO CHANGE AND / OR IMPROVEMENT WITHOUT NOTICE.