



revision B1 february 2007



# installation instructions and safety information



vehicular gate operator

# F-1



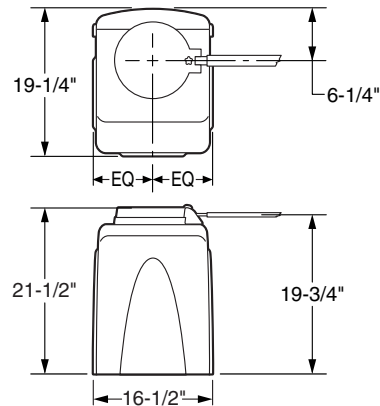
LISTED 18TC  
UL 325  
UL 991

CLASS I, CLASS II, CLASS III and CLASS IV

# PARTS DIAGRAM

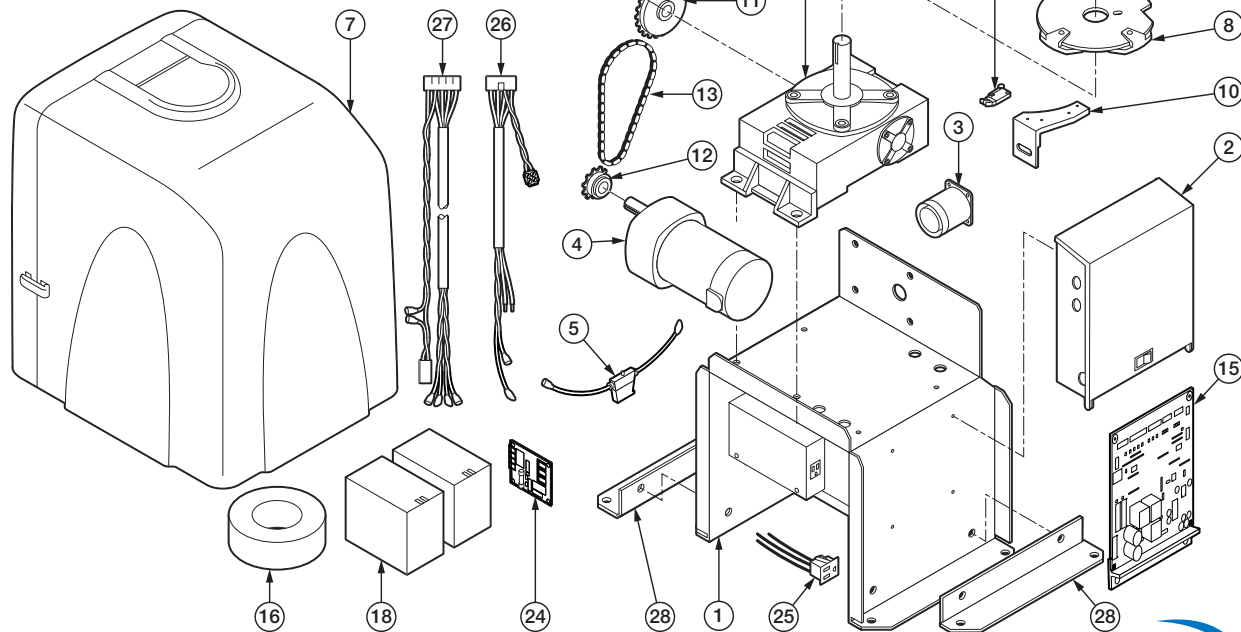
Item Description	Part No.
1 Chassis	DWCH10
2 Electric Box	DUEB10
3 Alarm	DUAL10
4 24V 1/2 HP DC Motor/Gear Assembly	DWMO10
5 Battery Fuse Holder	VABFH
6 Worm Gear #70 10:1	DWGB70
7 Operator Cover	DWCO10
8 Limit Cam & Holder	DWLC10
9 Limit switch (2)	DULS10
10 Limit switch Holder	DWLH10
11 Sprocket	DWSP30
12 Sprocket	DWSP10
13 Endless #40x46 Pitches	DWCA10
14 Clutch Key	VAWRCK
15 Control Board	DUPCB10
16 Toroid Transformer	DUTT10
17 Output Shaft Knob	DWOUK10
18 Battery (2)	DUBA10
19 Output Shaft	DWOP10
20 Clutch and Handle	DWCL10
21 Output Shaft Cover	DWOC10
22 Output Arm	DWAR10
23 Spacer	DWSPA10
24 EMI Board	DUEMI10
25 120V Receptacle	VA120PL
26 Power Harness	VAF1PHA
27 Limit Switch Harness	VALSWHA
28 Chassis Reinforcement Bracket (2)	DWCHRB
29 Warning Placard	DUWPA

## Overall Dimensions



## Weight

100 lb.



**WARNING - For Installation By Qualified Personnel Only.**



# TABLE OF CONTENTS

Parts Diagram/Parts List .....	i
<b>Important Safety Information</b>	
Important Safety Instructions .....	2
Important Installation Instructions .....	2-3
Maintenance/General Safety Precautions .....	4
Terminology .....	5
Photo Beam (non-contact sensor) Installation .....	6
Edge Sensor (contact sensor) Installation .....	7
Manual Release .....	7
Audible Alarm Reset Switch Installation .....	8
Warning Placard Installation .....	8
Important Installation Information .....	9
Specifications .....	9
<b>Plans of Installation .....</b>	<b>10</b>
<b>Plan of Installation – Concrete Pads .....</b>	<b>11</b>
<b>Gate Operator Installation</b>	
Step 1 through 5 – Operator Installation .....	12-13
<b>Electrical Installation</b>	
Electrical Installation .....	14
Single Unit Connections .....	15
<b>Gate Operator Installation</b>	
Step 6 – Limit Switch Setup .....	16-17
Limit Switch Connections .....	17
<b>Electrical Installation</b>	
Battery & EMI Borad Location .....	18
Master/Slave Connections .....	19
<b>Vehicular Loop Detector Installation</b>	
Loop Layout Diagrams .....	20
Installation Guidelines .....	21
<b>Accessory Connections</b>	
Open Commands; Safety Connections .....	22
Radio Receiver .....	23
Viking Electromagnetic Lock .....	24
Magnetic Lock; Solenoid Connection; Guard Station .....	25
<b>Special Features</b>	
Intelligent Obstruction Sensor (Primary Entrapment Protection) .....	26
Fail Safe/Fail Secure Operation; Hold Open Timer .....	27
Gate Overlap Setting .....	28
<b>Solar Panel Installation .....</b>	<b>29</b>
<b>Troubleshooting .....</b>	<b>31-33</b>



# **IMPORTANT SAFETY INFORMATION**

**WARNING - Not following these instructions may cause severe injury or death to persons.**

## **IMPORTANT SAFETY INSTRUCTIONS**

WARNING – To reduce the risk of severe injury or death:

1. READ AND FOLLOW ALL INSTRUCTIONS.
2. Never let children operate or play with gate controls. Keep the remote control away from children.
3. Always keep people and objects away from the gate. **NO ONE SHOULD CROSS THE PATH OF THE MOVING GATE.**
4. Test the gate operator monthly. The gate **MUST** reverse on contact with a rigid object or when an object activates the non-contact sensors. After adjusting the force or the limit of travel, retest the gate operator. Failure to adjust and retest the gate operator properly can increase the risk of injury or death.
5. Use the manual release only when the gate is not moving.
6. **KEEP GATES PROPERLY MAINTAINED.** Read the owner's manual. Have a qualified service person make repairs to gate hardware.
7. The entrance is for vehicles only. Pedestrians must use separate entrance.
8. **Every gate operator installation MUST have secondary protection devices against entrapment, such as edge sensors and photo beams more in particularly in places where the risk of entrapment is more likely to occur.**
9. SAVE THESE INSTRUCTIONS.

## **IMPORTANT INSTALLATION INSTRUCTIONS**

1. Install the gate operator only when:
  - a) The operator is appropriate for the construction of the gate and the usage Class of the gate (refer to page 5),
  - b) All openings of a horizontal slide gate are guarded or screened from the bottom of the gate to a minimum of 4 feet (1.22 m) above the ground to prevent a 2-1/4 inch (57.2 mm) diameter sphere from passing through the openings anywhere in the gate, and in that portion of the adjacent fence that the gate covers in the open position,
  - c) **ALL EXPOSED PINCH POINTS ARE ELIMINATED OR GUARDED, AND**
  - d) **GUARDING IS SUPPLIED FOR EXPOSED ROLLERS.**
2. The operator is intended for installation only on gates used for vehicles. Pedestrians must be supplied with a separate access opening. The pedestrian access opening shall be designed to promote pedestrian usage. Locate the gate such that persons will not come in contact with the vehicular gate during the entire path of travel of the vehicular gate.
3. The gate must be installed in a location so that enough clearance is supplied between the gate and adjacent structures when opening and closing to reduce the risk of entrapment. Swinging gates shall not open into public access areas.
4. The gate must be properly installed and work freely in both directions prior to the installation of the gate operator. Do not over-tighten the operator clutch or pressure relief valve to compensate for a damaged gate.
5. The gate operator controls must be placed so that the user has full view of the gate area when the gate is moving **AND AWAY FROM THE GATE PATH PERIMETER,**



# IMPORTANT SAFETY INFORMATION

**WARNING - Not following these instructions may cause severe injury or death to persons.**

## IMPORTANT INSTALLATION INSTRUCTIONS Continued

6. Controls intended for user activation must be located at least six feet (6') away from any moving part of the gate and where the user is prevented from reaching over, under, around or through the gate to operate the controls. Outdoor or easily accessible controls shall have a security feature to prevent unauthorized use.
7. The Stop and/or Reset button must be located in the line-of-sight of the gate. Activation of the reset control shall not cause the operator to start.
8. All warning signs and placards must be installed where visible in the area of the gate. A minimum of two placards shall be installed. A placard is to be installed in the area of each side of the gate and be visible to persons located on the side of the gate on which the placard is installed.
9. **For gate operators utilizing a non-contact sensor (Photo beam or like) in accordance with section 31.1.1 of the UL325 standard:**
  - a) **See instructions on the placement of non-contact sensors for each Type of application (refer to page 6),**
  - b) **Care shall be exercised to reduce the risk of nuisance tripping, such as when a vehicle, trips the sensor while the gate is still moving, and**
  - c) **One or more non-contact sensors shall be located where the risk of entrapment or obstruction exists, such as the perimeter reachable by a moving gate or barrier (refer to page 6).**
  - d) **Use only Omron E3K-R10K4 photoelectric eye to comply with UL325**
10. **For a gate operator utilizing a contact sensor (Edge sensor or like) in accordance with section 31.1.1 of the UL325 standard:**
  - a) **One or more contact sensors shall be located where the risk of entrapment or obstruction exists, such as at the leading edge, trailing edge, and post mounted both inside and outside of a vehicular horizontal slide gate (refer to page 7).**
  - b) **One or more contact sensors shall be located at the bottom edge of a vehicular vertical lift gate.**
  - c) **One or more contact sensors shall be located at the pinch point of a vehicular vertical pivot gate.**
  - d) **A hardwired contact sensor shall be located and its wiring arranged so that the communication between the sensor and the gate operator is not subjected to mechanical damage.**
  - e) **A wireless contact sensor such as one that transmits radio frequency (RF) signals to the gate operator for entrapment protection functions shall be located where the transmission of the signals are not obstructed or impeded by building structures, natural landscaping or similar obstruction. A wireless contact sensor shall function under the intended end-use conditions.**
  - f) **One or more contact sensors shall be located on the inside and outside leading edge of a swing gate. Additionally, if the bottom edge of a swing gate is greater than 6 inches (152 mm) above the ground at any point in its arc of travel, one or more contact sensors shall be located on the bottom edge (refer to page 7).**
  - g) **One or more contact sensors shall be located at the bottom edge of a vertical barrier (arm).**
  - h) **Use only Miller Edge Model MGR20 or MGS20 edge sensor to comply with UL325**



# IMPORTANT SAFETY INFORMATION

**WARNING - Not following these instructions may cause severe injury or death to persons.**

## MAINTENANCE

Remove the Power Harness from the Control Board (refer to page 15)

- Clean and lubricate the turning pins and gate hinges using the recommended lubricant.
- Check that all mounting hardware of the gate operator is properly tighten.
- Ensure that the gate moves freely.
- Check for corroded parts and replace if necessary.
- Check the battery for the following:
  - Battery connections must be free of corrosion.
  - Battery voltage must be 26 VDC (fully charged battery).

Reconnect the Power Harness for the Control Board (refer to page 15)

- Check and confirm the proper operation of all safety devices (photoelectric eye, edge sensors or like).
- Check and confirm the operation of all installed accessories.
- Check and confirm the operation of all special features such as the Intelligent Obstruction Sensor, Hold Open Timer (refer to page 22 to 28)
- Check and confirm the operation of the manual release (refer to page 7)
- Verify battery backup functionally by turning off the power source (120 VAC and 220 VAC). **DO NOT FORGET TO TURN ON THE POWER SOURCE AFTER VERIFICATION.**

## GENERAL SAFETY PRECAUTIONS

The following precautions are an integral and essential part of the product and must be supplied to the user. Read them carefully as they contain important indications for the safe installation, use and maintenance.

- These instruction must be kept and forwarded to all possible future users of the system.
- This product must be used only for that which it has been expressly designed.
- Any other use is to be considered improper and therefore dangerous.
- The manufacturer cannot be held responsible for possible damage caused by improper, erroneous or unreasonable use.
- Avoid operating in the proximity of the hinges or moving mechanical parts.
- Do not enter the path of the moving gate while in motion.
- Do not obstruct the motion of the gate as this may cause a situation of danger.
- Do not allow children to play or stay within the the path of the moving gate.
- Keep remote control or any other control devices out of the reach of children, in order to avoid possible involuntary activation of the gate operator.
- In case of break down or malfunctioning of the product, disconnect from the main power source. Do not attempt to repair or intervene directly, contact only qualified personnel for repair.
- Failure to comply with the above may create a situation of danger.
- All cleaning, maintenance or repair work must be carried out by qualified personnel.
- In order to guarantee that the system works efficiently and correctly it is important to have the manufacturer's instructions on maintenance of the gate and operator carried out by qualified personnel.
- In particular, regular checks are recommended in order to verify that the safety devices are operating correctly.

All installation, maintenance and repair work must be documented and made available to the user.

Installer:

Signature \_\_\_\_\_

Date \_\_\_\_\_

Contact: \_\_\_\_\_



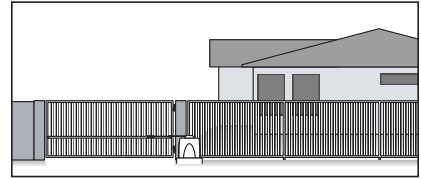
# TERMINOLOGY

## UL325 Gate Operator Classification

### GLOSSARY

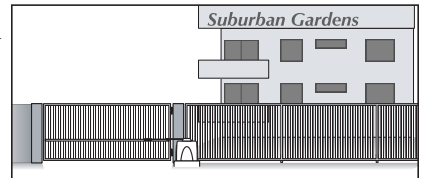
#### RESIDENTIAL VEHICULAR GATE OPERATOR

CLASS I – A vehicular gate operator (or system) intended for use in a home of one-to four single family dwelling, or a garage or parking area associated therewith.



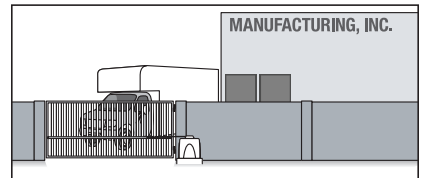
#### COMMERCIAL/GENERAL ACCESS VEHICULAR GATE OPERATOR

CLASS II – A vehicular gate operator (or system) intended for use in a commercial location or building such as a multi-family housing unit (five or more single family units), hotel, garages, retail store, or other building servicing the general public.



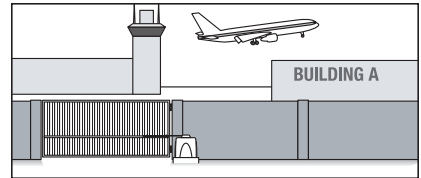
#### INDUSTRIAL/LIMITED ACCESS VEHICULAR GATE OPERATOR

CLASS III – A vehicular gate operator (or system) intended for use in an industrial location or building such as a factory or loading dock area or other locations not intended to service the general public.



#### RESTRICTED ACCESS VEHICULAR GATE OPERATOR

CLASS IV – A vehicular gate operator (or system) intended for use in a guarded industrial location or building such as an airport security area or other restricted access locations not servicing the general public, in which unauthorized access is prevented via supervision by security personnel.



Install the gate operator only when:

The operator is appropriate for the construction of the gate and the Usage Class of the gate.



# IMPORTANT SAFETY INFORMATION

**WARNING - Not following these instructions may cause severe injury or death to persons.**

**NOTE - This type of installation DOES NOT reverse the gate all the way back to its limits when the photo-beam is obstructed. This installation is only to protect against entrapment and to comply with UL325.**

## Photo Beam (non-contact sensor) Installation

### Secondary Entrapment Protection

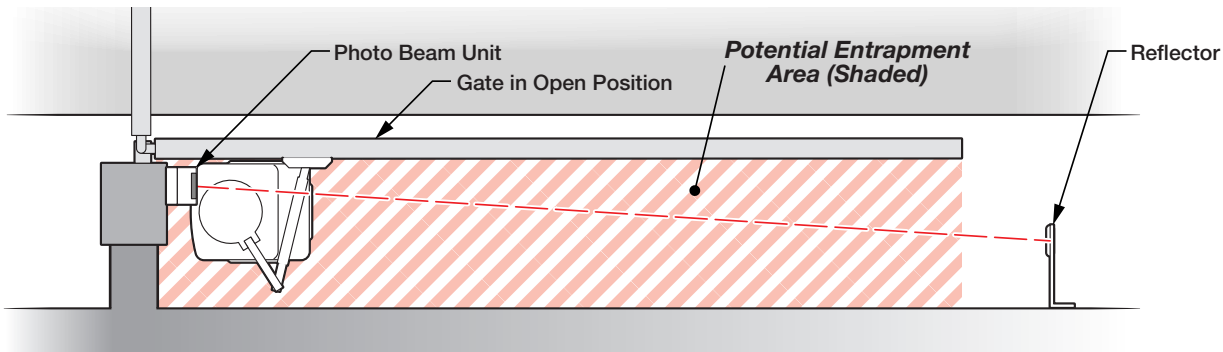
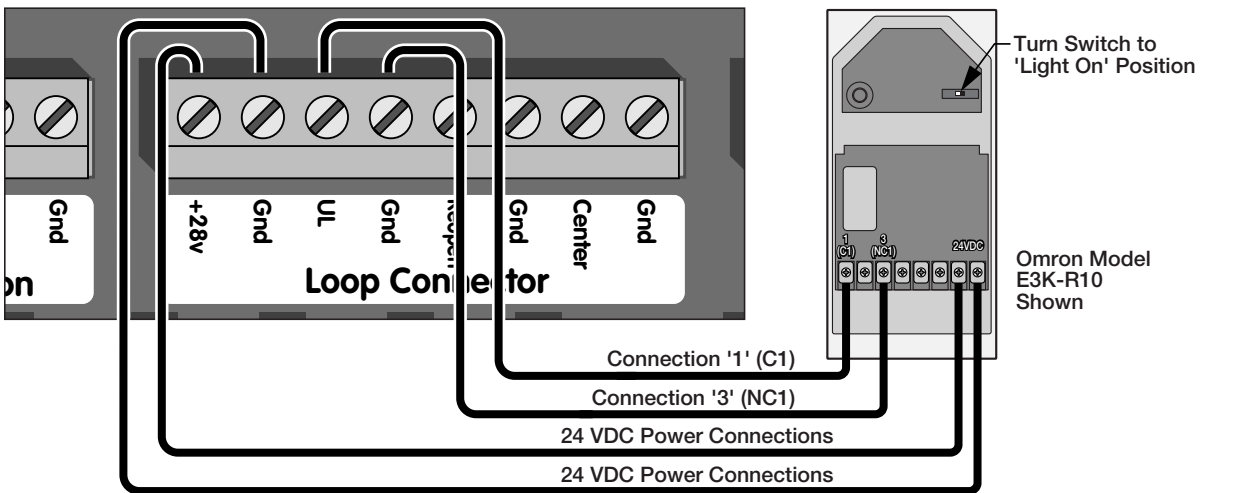
**Photo beams or like must be installed to reduce the risk of entrapment.**

Use only Omron E3K-R10K4 photoelectric eye to comply with UL325

Make the electrical connections of the photoelectric sensor as described here in this page.

Care shall be exercised to reduce the risk of nuisance tripping, such as when a vehicle, trips the sensor while the gate is still moving, and

One or more non-contact sensors shall be located where the risk of entrapment or obstruction exists, such as the perimeter reachable by a moving gate or barrier.



One or more non-contact sensors shall be located where the risk of entrapment or obstruction exists, such as the perimeter reachable by a moving gate or barrier.

Consult the installation manual for the UL325 device (photo beam or like) for detail information about the usage, installation and maintenance.



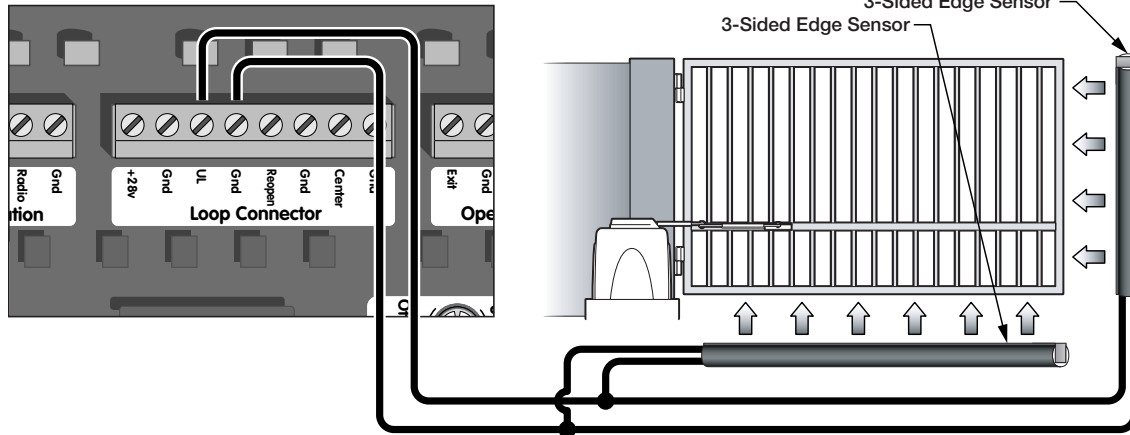


# IMPORTANT SAFETY INFORMATION

**WARNING - Not following these instructions may cause severe injury or death to persons.**

## Edge Sensor (contact sensor) Installation

### Secondary Entrapment Protection

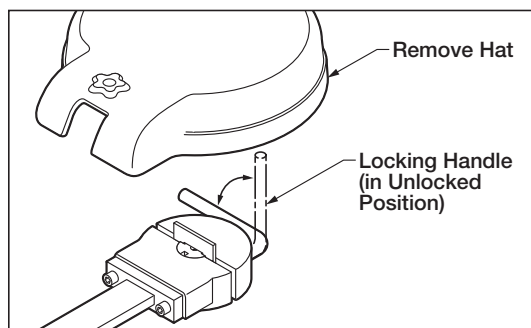


#### Edge sensor or like must be installed to reduce the risk of entrapment.

Use only Miller Edge 3-sided activation type MGR20 or MDS20 to comply with UL325. One or more contact sensors shall be located on the inside and outside leading edge of a swing gate. Additionally, if the bottom edge of a swing gate is greater than 6 inches (152 mm) above the ground at any point in its arc of travel, one or more contact sensors shall be located on the bottom edge.

1. A hardwired contact sensor shall be located and its wiring arranged so that the communication between the sensor and the gate operator is not subjected to mechanical damage.
2. A wireless contact sensor such as one that transmits radio frequency (RF) signals to the gate operator for entrapment protection functions shall be located where the transmission of the signals are not obstructed or impeded by building structures, natural landscaping or similar obstruction. A wireless contact sensor shall function under the intended end-use conditions.

## Manual Release



#### When manual operation is required:

1. Remove the Hat
2. Lift the Locking Handle.
3. Remove the Clutch Key

#### To reengage the gate operator:

1. Align the Clutch and the notches on the Output Shaft.
2. Insert the Clutch Key.
3. Push down the Locking Handle.
4. Reattach the Hat.

**Attention: Lock and release operations MUST be performed with motor NOT RUNNING.**



# IMPORTANT SAFETY INFORMATION

**WARNING - Not following these instructions may cause severe injury or death to persons.**

## Audible Alarm Reset Switch Installation

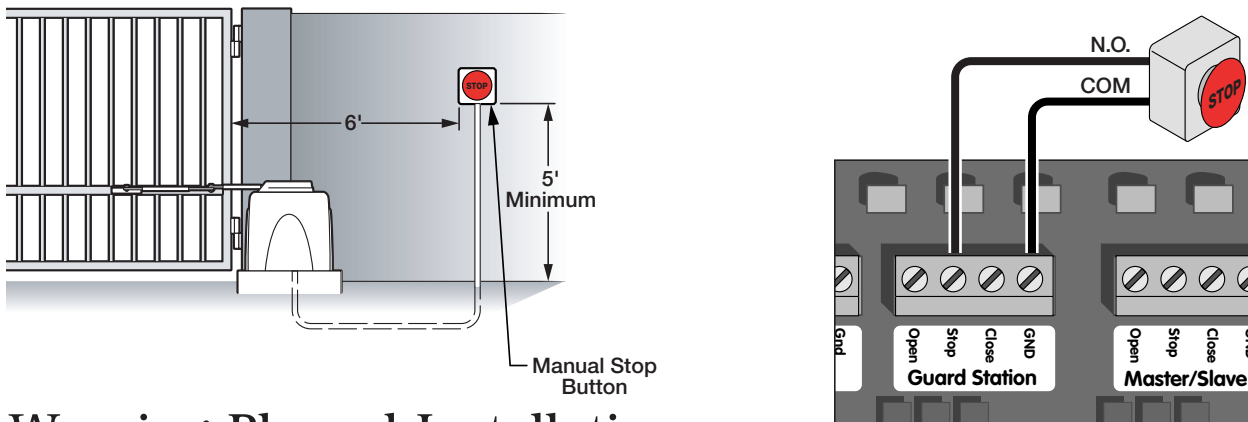
### Manual Reset for the Audible Alarm

UL325 standard requires an audible alarm to go off after two consecutive events detected by the primary entrapment protection of the gate operator (obstruction sensor).

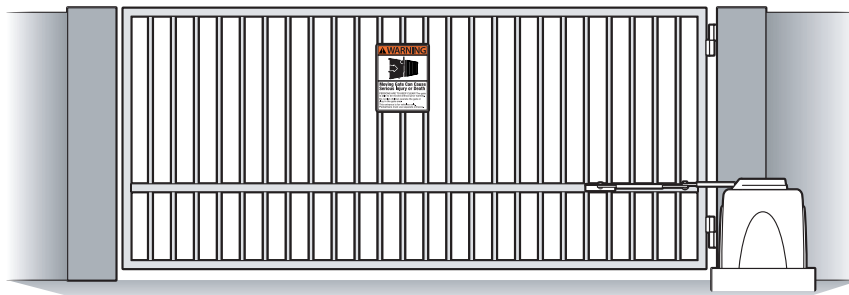
The audible alarm will continue to sound for 5 minutes or until a stop command gets actuated.

The Stop command can be actuated in two different forms

1. Using the Built in Stop switch on the Control Box or
2. Using an External Stop button within the sight of the gate, away from moving parts of the gate and out of reach of children.
3. Controls intended for user activation must be located at least six feet (6') away from any moving part of the gate and where the user is prevented from reaching over, under, around or through the gate to operate the controls. Outdoor or easily accessible controls shall have a security feature to prevent unauthorized use.
4. The Stop and/or Reset button must be located in the line-of-sight of the gate. Activation of the reset control shall not cause the operator to start.



## Warning Placard Installation



All Warning Signs and Placards must be installed where visible in the area of the gate. A minimum of two placards shall be installed. A placard is to be installed in the area of each side of the gate and be visible.

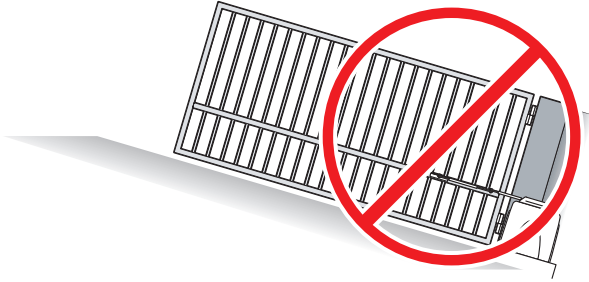


# IMPORTANT INSTALLATION INFORMATION

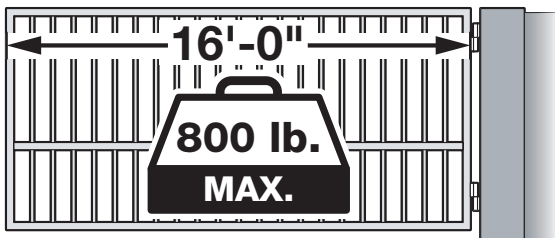
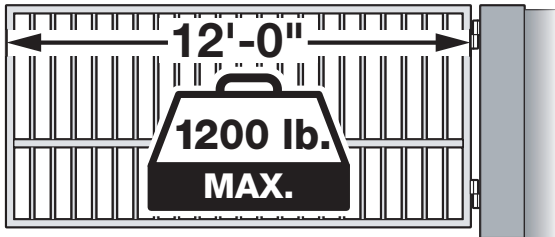
**CAUTION - FOR USE WITH GATES OF A MAXIMUM OF 12 FT IN LENGTH AND 1200 LBS. IN WEIGHT OR 16 FT IN LENGTH AND 800 LBS. IN WEIGHT.**  
**WARNING - TO REDUCE THE RISK OF SEVERE INJURY OR DEATH TO PERSONS:**



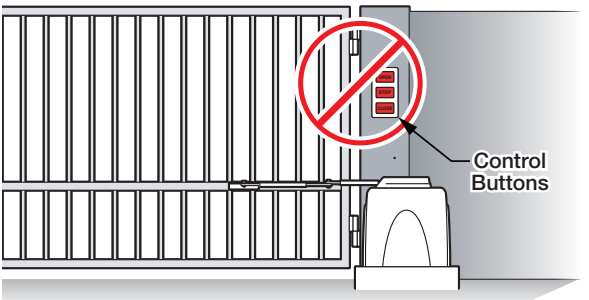
This is NOT a pedestrian gate operator



Do NOT Install the gate operator to lift gates



1200 pounds maximum gate weight at 12' maximum gate length.  
800 pounds maximum gate weight at 16' maximum gate length



Locate Control Buttons:

1. Within sight of the gate,
2. At a minimum height of 5 feet so small children are not able to reach it, and
3. Away from all moving parts of the gate.

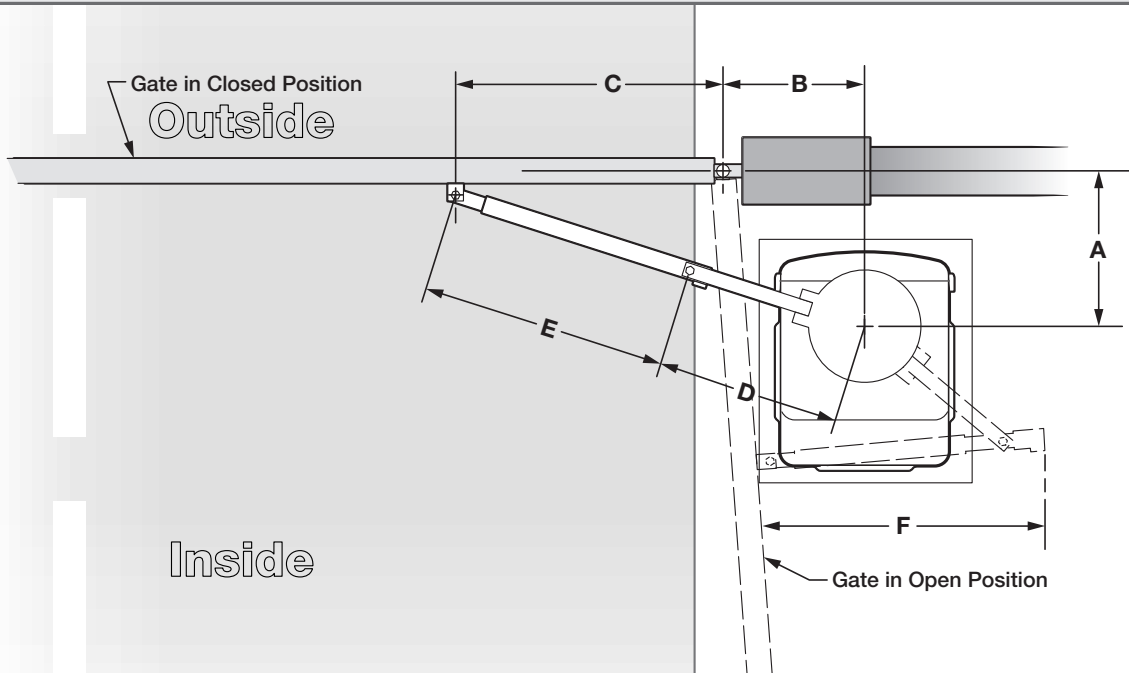
## Specifications

Maximum Gate Length:	16 feet at 800 lbs., 12 feet at 1200 lbs.
Maximum Gate Weight:	1200 lbs. at 12 feet, 800 lbs. at 16 feet
Maximum Aperture Angle:	120 deg.
Power Requirements:	120 VAC Single Phase at 2 Amps Or 220 VAC Single Phase at 1 Amp
Operating Temperature:	-20°C (-4°F) to 70°C (158°F)



# PLANS OF INSTALLATION

The gate must be installed in a location so that enough clearance is supplied between the gate and adjacent structures when opening and closing to reduce the risk of entrapment. Swinging gates shall not open into public access areas.



Dimensional Formula					
A	B	C	D	E	F
(min= 11.5)	(min= 9.5)	A + 12	*	D x 1.45	approx. E + 5

\* Set D and E such that the arm is straight when the gate is closed.

The installation shown using the Straight Arm Secondary Extension can NOT be back-driven. If a back-driven installation is required, an Elbow Arm Secondary Extension can be used. Contact Viking Access for availability.

The following are some examples:

NORMAL INSTALLATION					
A	B	C	D	E	F
13.75	10.5	22	14.75	21.5	23.25
13.75	10.5	26.5	14.75	23.5	24.25
13.75	10.5	26.5	17.75	23.5	25
13.75	10.5	39.5	22.5	33.5	30.5

LONG DISTANCE OR RETROFIT INSTALLATION					
A	B	C	D	E	F
27	10.5	35	22.5	29.5	30
27	10.5	39.5	22.5	33.5	32

\*Note: The dimensions provided are just a guideline. Each site may have different geometries or possibilities of installation. The key for installation is to have "E" longer than "D" and to adjust the arms such that the arm is straight at the closed position.

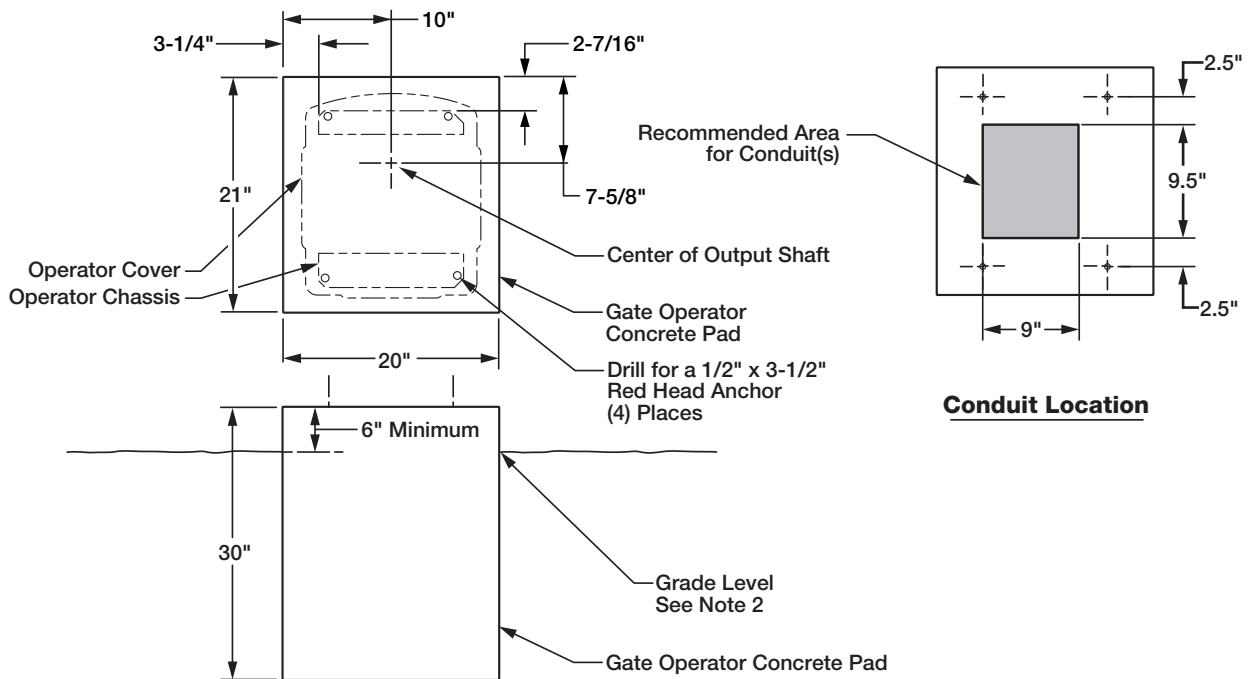
COMPACT INSTALLATION					
A	B	C	D	E	F
11.5	9.5	18.75	12	17.25	19.25
11.5	9.5	22	13.75	19.5	21
11.5	9.5	22	13.75	20	21.25
11.5	9.5	22	14.75	21.5	23.5

Figure A  
Plan of Installation



# PLAN OF INSTALLATION – DETAILS

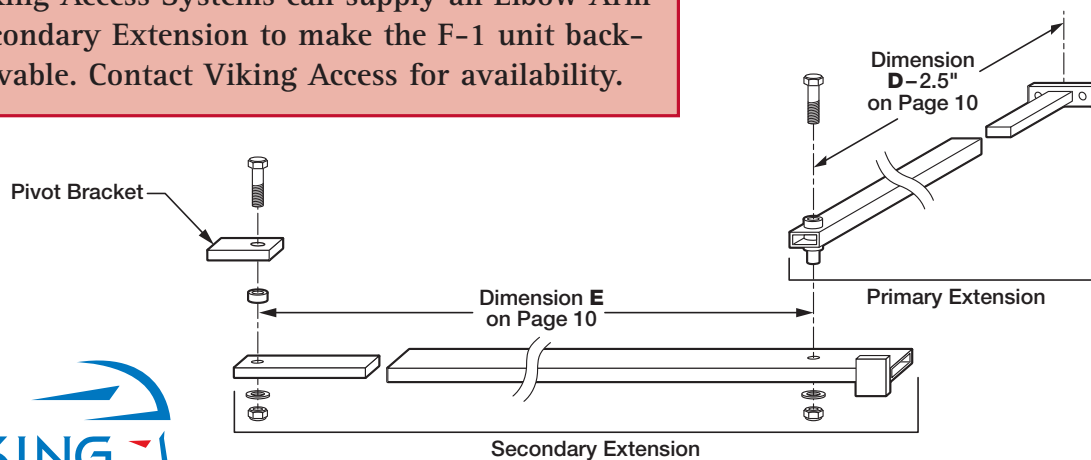
## Concrete Pad



1. Follow the local building code to determine the required depth of the concrete pad.
2. Pad measurements recommended by Viking Access Systems are at least 20" long, 20" wide and 30" deep to ensure the stable operation of the operator, and a minimum of 6" above level grade to avoid any flooding of the machinery.
4. Provide a sufficient number of conduit pathways for all low power accessories such as loop detector leads, maglock, non-contact sensors, contact sensors, safety and other commands. Also provide conduit for the power supply (either 110 or 220 VAC). Extend the conduit the recommended height of 1" above the level of the concrete pad. Install all conduit in the shaded area shown above.

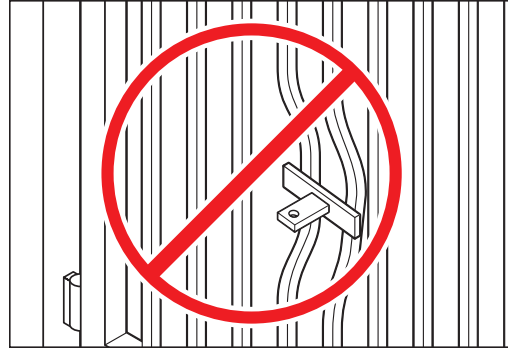
## Arm Assembly

Viking Access Systems can supply an Elbow Arm Secondary Extension to make the F-1 unit back-drivable. Contact Viking Access for availability.



# GATE OPERATOR INSTALLATION

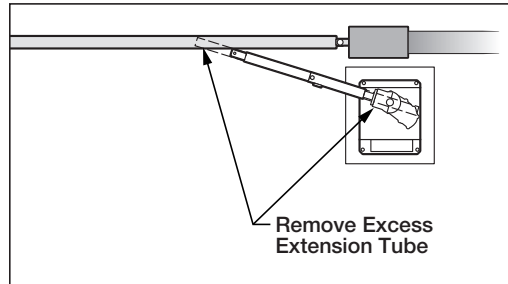
**CAUTION** - If mounting bar is not welded to a frame member that runs the full length of the gate, the gate operator may damage the gate. Do not weld the bar or backing plate to a few pickets.



## STEP 1

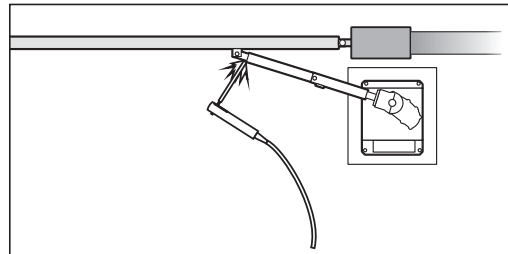
Release the clutch (see page 7). Cut the extension arms according to the desired plan of installation (Figure A on page 10).

Note: Leave some additional material when cutting the extension arms to allow for additional adjustment.



## STEP 2

Position the pieces of the articulated arm with the gate in the closed position. Ensure that the dimensions correspond to the chosen plan of installation. Use C-clamps or tack-weld pieces to aid in the pre-installation process.

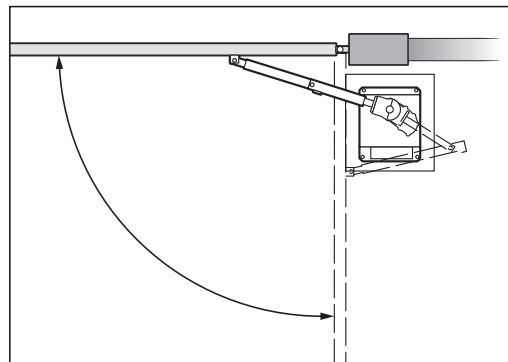


## STEP 3

With the clutch released, move the gate manually from the completely open to the completely closed position. Verify that:

- A. The gate and arm combination can provide the desired operation.
- B. The arm does not bind in its movement, especially in the open position.

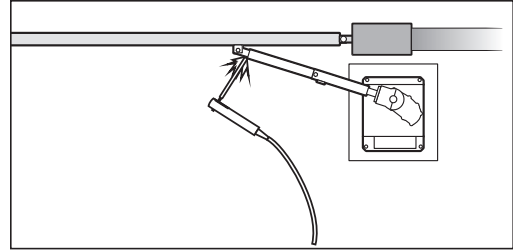
Note: The total travel angle of the primary arm on the output shaft determines the speed of the gate operation. The smaller the travel angle, the quicker the gate will open and close.



# GATE OPERATOR INSTALLATION

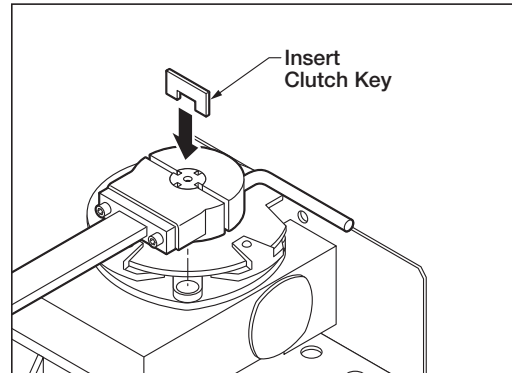
## Step 4

Upon observation of the satisfactory arrangement of the articulated arm and bracket, weld all pieces securely. Paint the arm to protect it from rusting.



## STEP 5

Upon test of the installation, loosen the clutch and rotate it until it lines up with the notches in the Output Shaft. Insert the Clutch Key.

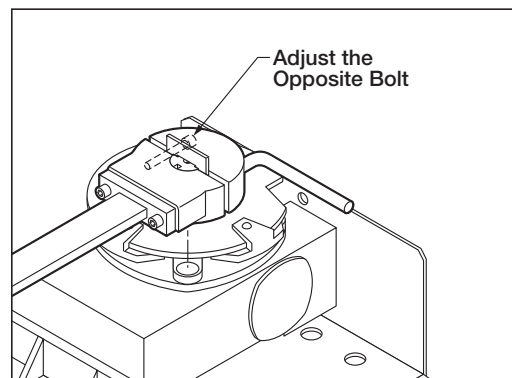
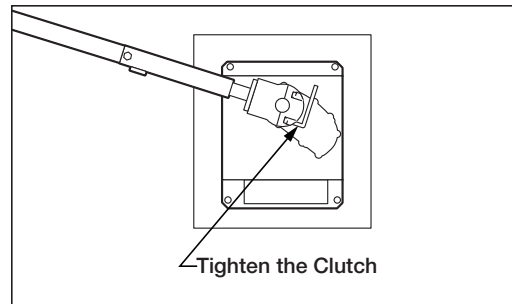


## STEP 6

Check the Clutch adjustment. The Clutch is shipped factory adjusted. The clutch must be tight enough to prevent slippage in normal operation.

Check the tightness of the Clutch:

- A. Remove the Clutch Key from the clutch.
- B. Attempt to move the gate by hand.
- C. If slippage occurs:
  1. Loosen the Locking Handle 180°
  2. Tighten the opposite bolt.
  3. Tighten the Locking Handle 180°
  4. Check the tightness of the clutch again.

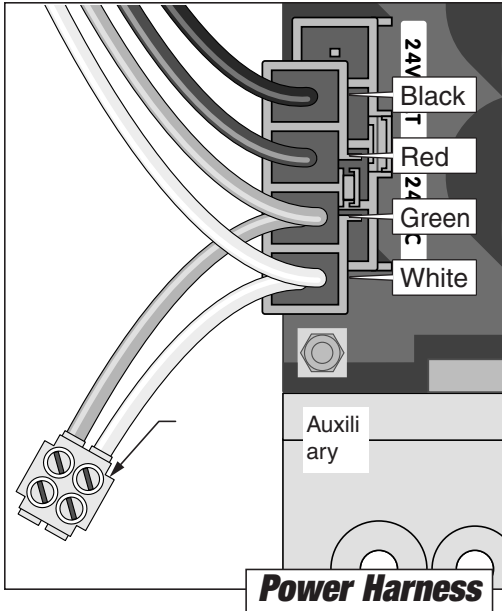


**NOTE** – For proper operation of the Clutch, keep the gap between the Clutch halves even when adjusting (the Clutch will have to be removed from the Output Shaft in order to adjust the Release Handle bolt).



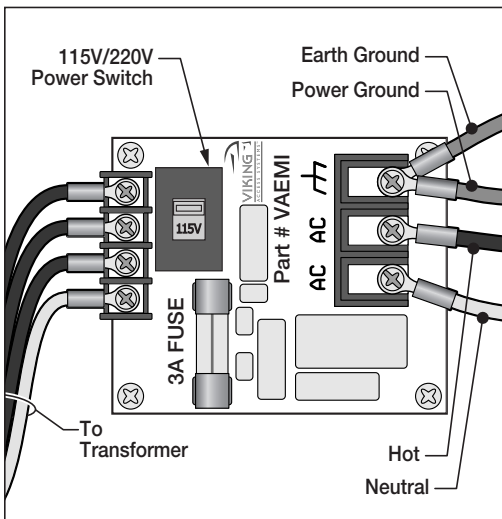
# ELECTRICAL INSTALLATION

**Caution – Do not connect the power harness to the board until the installation is ready for verification.**



The Gate Operator requires a single phase AC line to operate and charge the batteries.

1. Turn off the main switch or breaker for the power line being used.
2. Move the selector switch on the Incoming Voltage Selector to the proper position (115 for 110 to 120VAC, 230 for 200 to 240VAC).
3. Connect the incoming power wires to the terminals as shown in the illustration.
4. Turn on the main switch or breaker once the installation is ready for final adjustments.
5. To verify that there is AC power to the system, check that the 'Charger' LED on the Control Board is on.

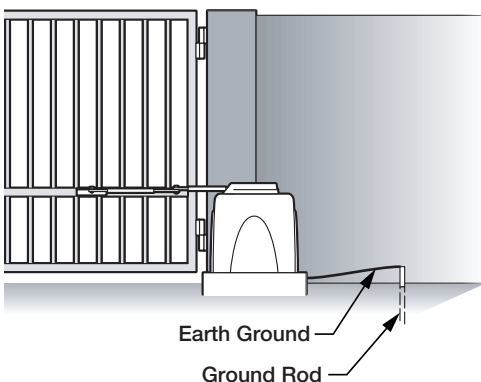


## Tips for proper ground installation

A good ground in a gate operator installation will minimize or prevent damage to the operator cause by natural events such as lightning strikes.

The following will provide a guideline for proper grounding:

1. Use a ground rod to provide a ground reference.
2. Consult your city code and be aware of under-ground services in the site of the gate operator to prevent inconveniences.
3. Use always a single bonding point for grounding.
4. All ground wires must be as short and as thick as possible.
5. Prevent unnecessary turns or loops in all ground wires.

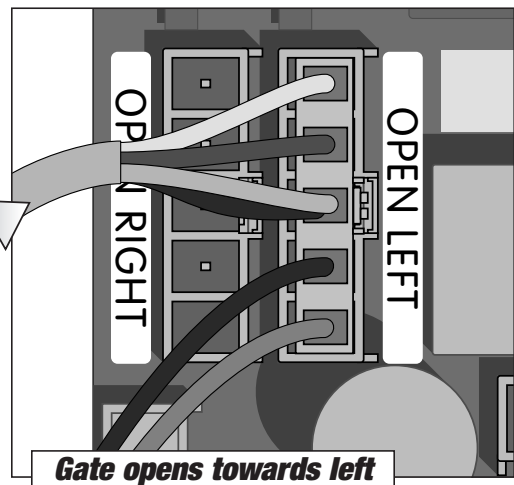
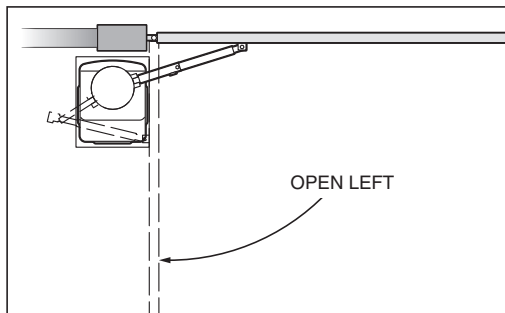
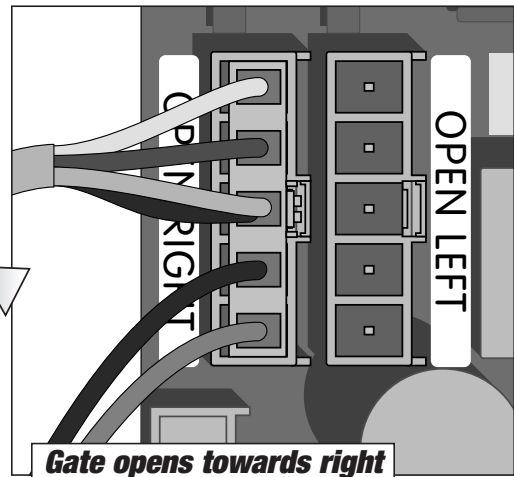
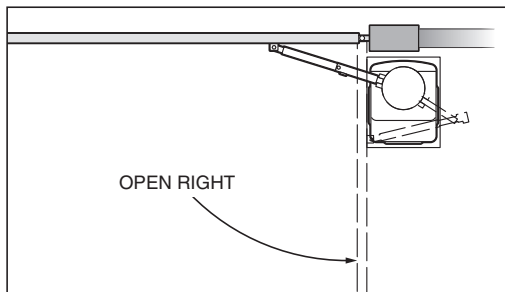




# ***ELECTRICAL INSTALLATION – SINGLE UNIT***

## Power Connections

Connect the wire harness to the “OPEN RIGHT” connector if the gate opens to the right.  
Connect the wire harness to the “OPEN LEFT” connector if the gate opens to the left.



# LIMIT SWITCH SET-UP

## Limit Switch Setup

### STEP 7

- Loosen the screws on the Limit Switch Cams.
- With the operator cover still off, remount the articulated arm, making sure the cam wheel pin is engaged with the clutch.
- Move the gate manually to the closed position.
- Move the Limit Switch Cams on the Cam Wheel to actuate each limit switch.

#### **Gate Opens to Right**

Left Limit Switch	Open limit
-------------------	------------

Right Limit Switch	Close limit
--------------------	-------------

#### **Gate Opens to Left**

Left Limit Switch	Close limit
-------------------	-------------

Right Limit Switch	Open limit
--------------------	------------

(see diagram on right to determine which direction to move the cams)

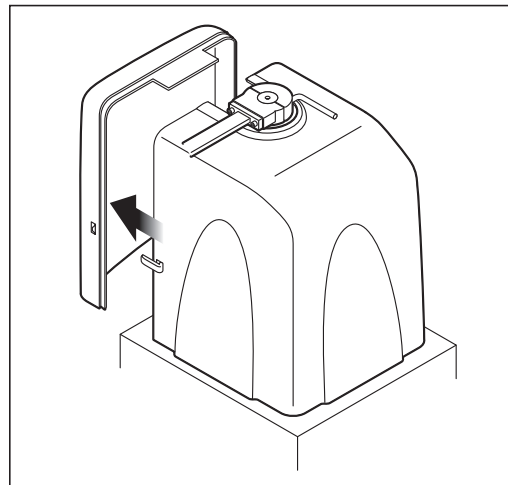
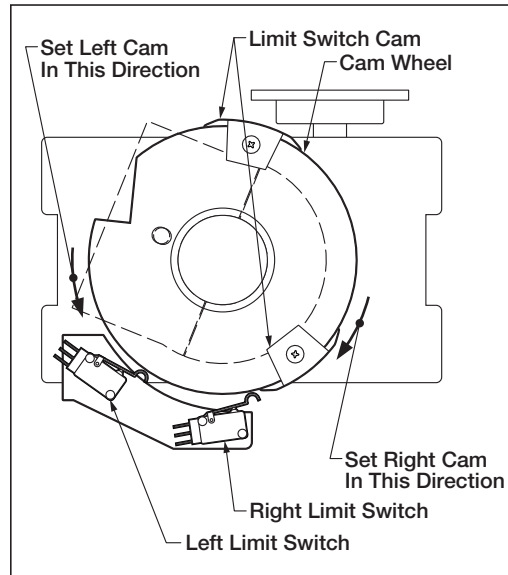
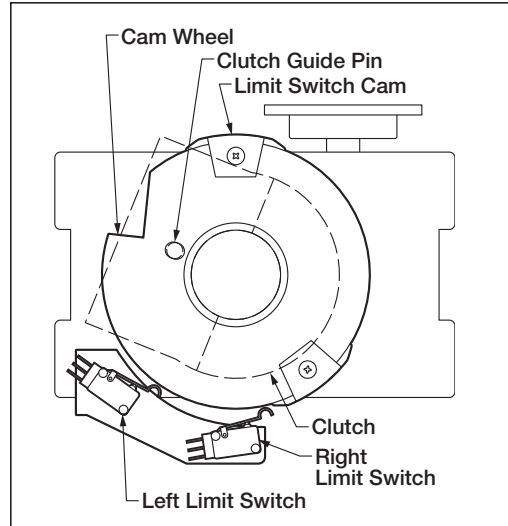
- Slightly tighten the screw on the Limit Switch Cam.
- Move the gate manually to the open position. Repeat steps a, b and c for the other cam.
- Run the unit 2 full cycles without interruption (from limit to limit) to execute a "Learn Cycle."
- Fine-tune the adjustment of the Limit Switch Cams.

Note:

Ensure that the cams move without restriction through the course of the arm's movement.

### Step 8

Install the Clamshell Cover by carefully slipping the front half over the Limit Switches and Cam Wheel., then fitting the back cover in place. Latch the hasps on both sides of the Cover.



# LIMIT SWITCH SET-UP

## Opening/Closing Setup

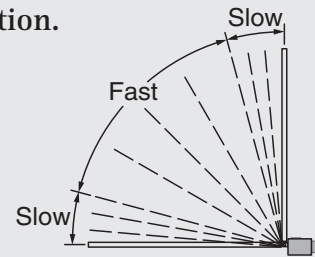
1. Setup the limit switches manually at the desired open and close position.
2. Allow the gate operator to run a full open and close cycle (from limit to limit) without interruption.

Note: During the first full open and close cycle: The gate operator doesn't slow down prior to reaching its limits. During subsequent cycles: The gate operator will slow down prior to reaching its limits.

3. Verify that the gate opens and closes to the desired position.

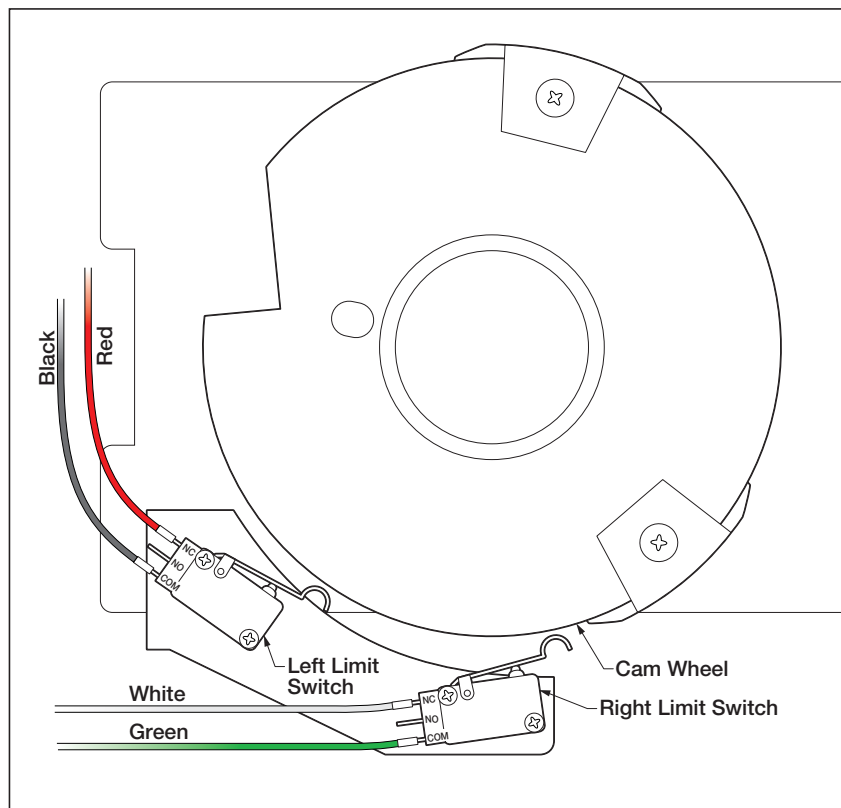
To change the open or close limit position(s) the following steps MUST BE taken:

- A. Reset the gate operator by actuating both limit switches at the same time
- B. Repeat steps 1,2 and 3.

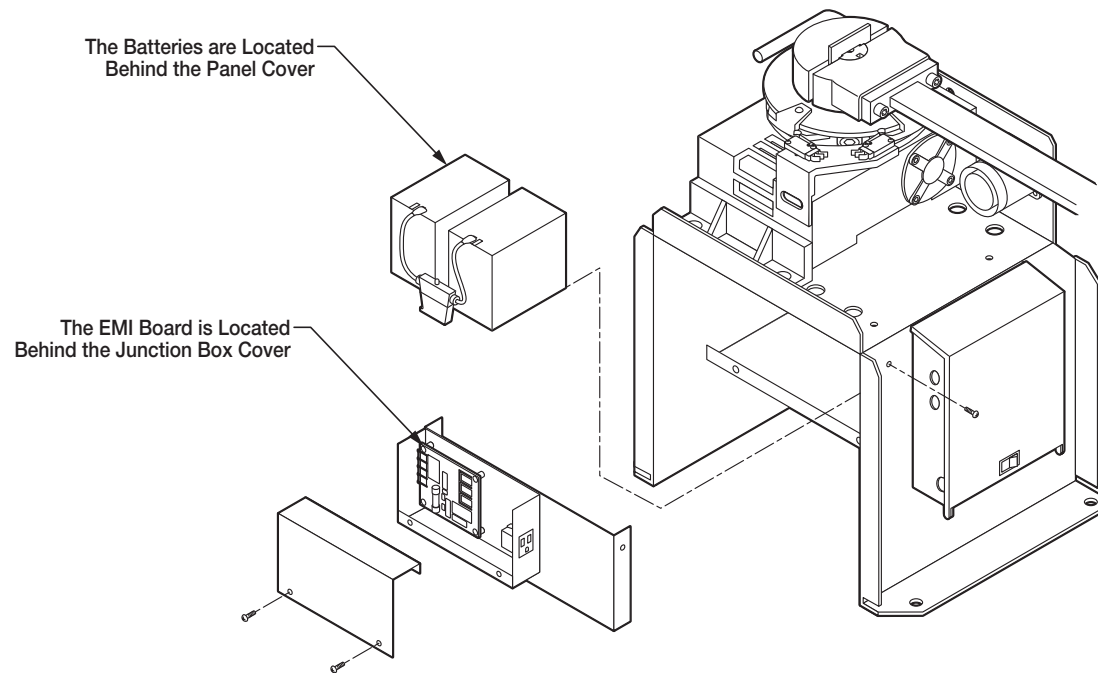


## Limit Switch Connections

The Limit Switches are wired as shown

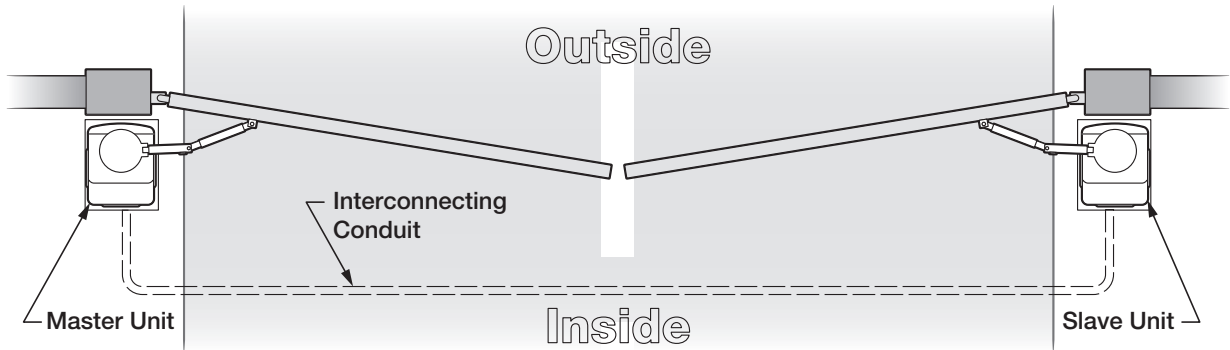


# BATTERY & EMI BOARD LOCATION

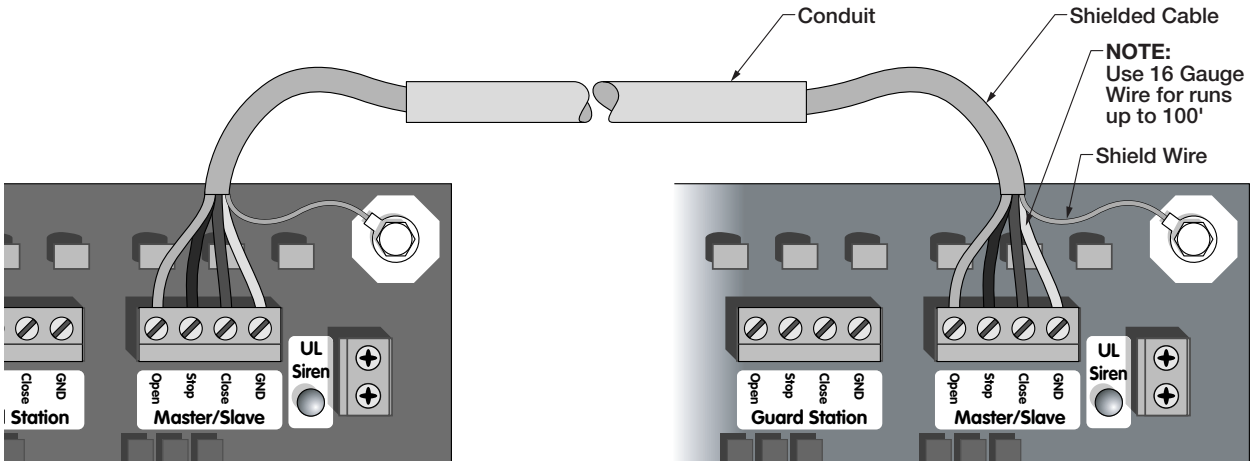


# ELECTRICAL INSTALLATION – MASTER/SLAVE

## Master/Slave Connections



**Caution – Do not run Master/Slave communication cable in the same conduit as the power supply (120-220V) cable.**



The control board provides a connector for master/slave connectivity. This connector will allow synchronized operation with a second gate operator.

Wire the operators as shown above and interconnect the two operators as follows:

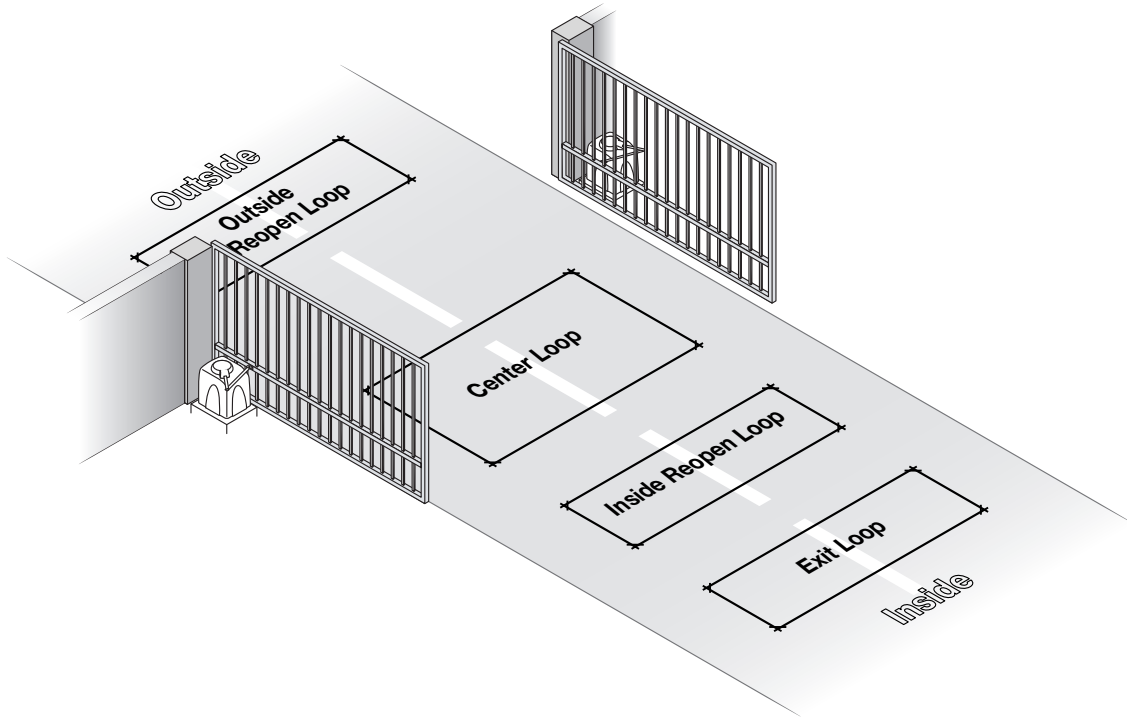
Master Board	Slave Board	Purpose
GND	.GND	Reference
Close	.Close	Close Command
Stop	.Stop	Stop Command
Open	.Open	Open Command
Shield (to Earth)	Shield (to Earth)	

For Overlap Delay see page 28.

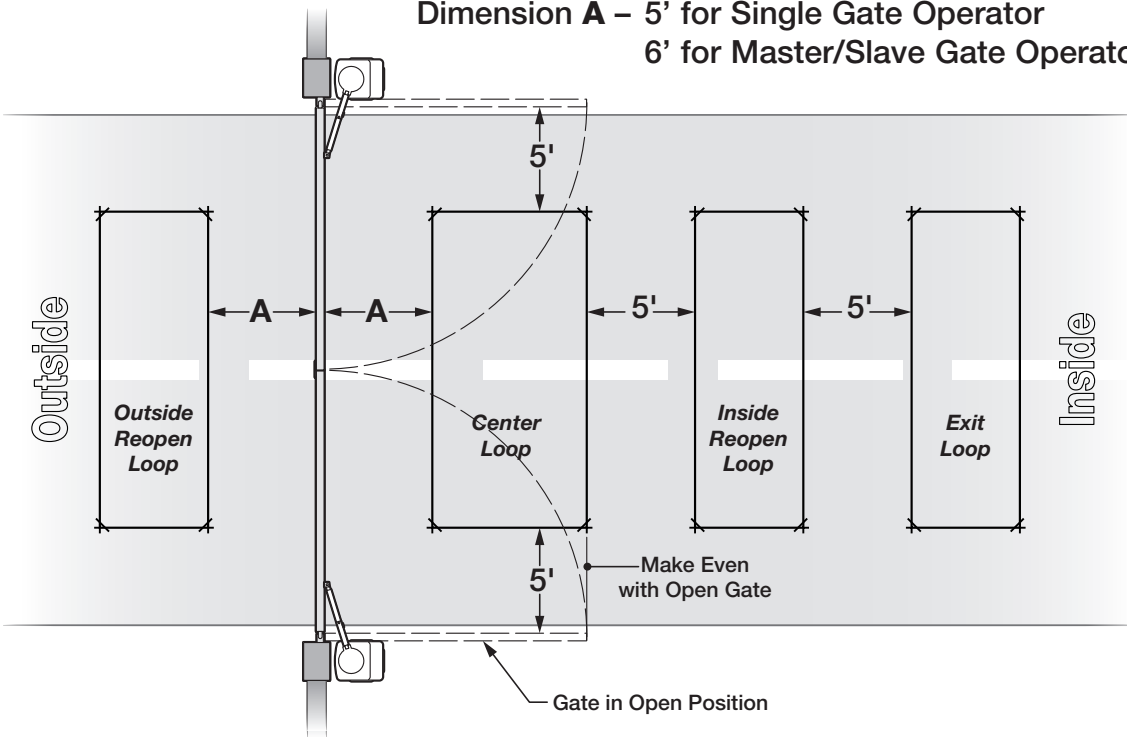
Note: It is recommended to connect all external devices and set timer and overlap delay control on the master unit. Ensure Slave Control Board has timer set to 'OFF' to allow the Master to control the timer.



# VEHICULAR LOOP DETECTOR INSTALLATION



Dimension A – 5' for Single Gate Operator  
6' for Master/Slave Gate Operator



# VEHICULAR LOOP DETECTOR INSTALLATION

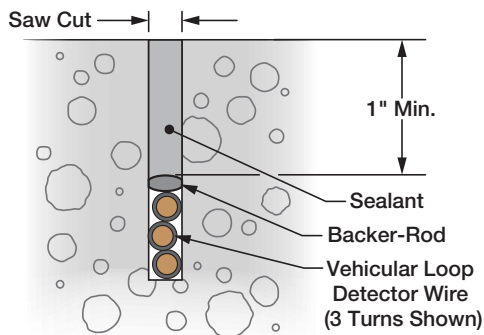
**WARNING** – Consult the installation instructions from the loop detector manufacturer. The following statements are provided as a guide but different requirements may be required by the vehicular loop detector manufacturer.

## Guidelines for Vehicular Loop Detector Installation

1. Prevent sharp corners in the geometry of the loop sensor.
2. Install the appropriate number of turns for your loop geometry based on the loop perimeter. Use Table C (below) as a guide.
3. Use XLP (cross-linked-polyethylene) type of wire. This wire reduces the effects of moisture and other environmental events in altering the functionality of the vehicular loop detector.
4. Twist the lead wire at least 6 turns per foot.
5. Use BACKER-ROD to minimize damage to the loop detector wire prior to using the sealant.
6. Place the loop detector wire and adjust the sensitivity of the vehicular loop detector unit in a way to minimize the effects of the gate over the loop detector wire.

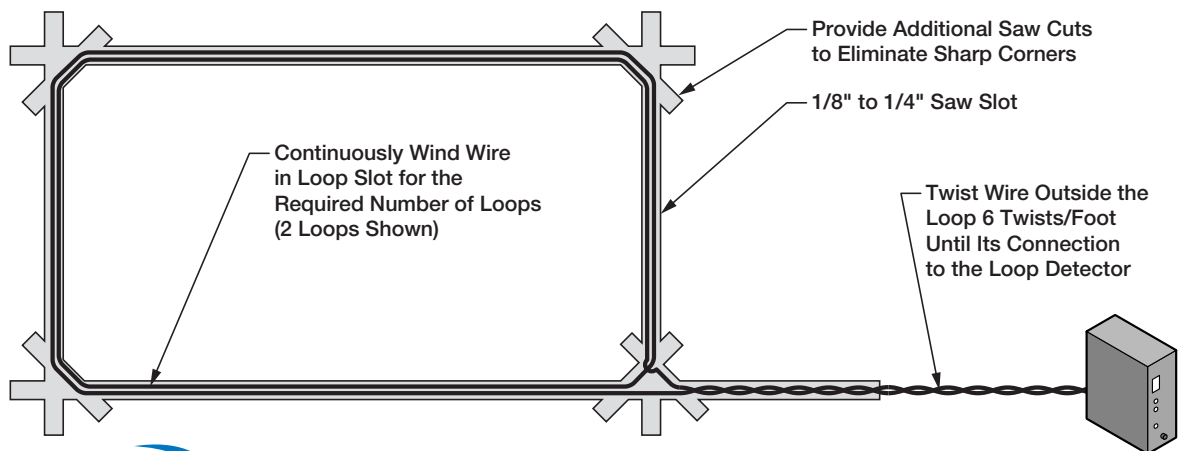
**IMPORTANT** – Some of the following parameters may affect the proper functionality of the vehicular loop detector (consult the installation manual and the manufacturer of the vehicular loop detector).

- Gate size,
- Number of turns in the loop sensor wire;
- Distance from the loop sensor wire to the gate either at the open or close position.

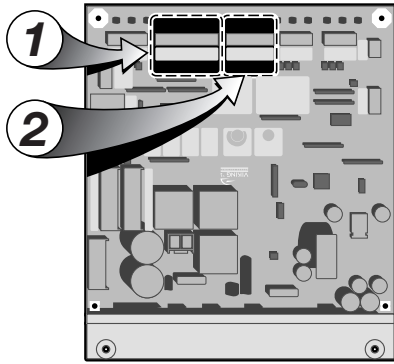


**Table C – Recommended Number of Turns**

Perimeter in Feet	Number of Turns
10	5
20	4
30-40	3
50-100	2



# ACCESSORY CONNECTIONS



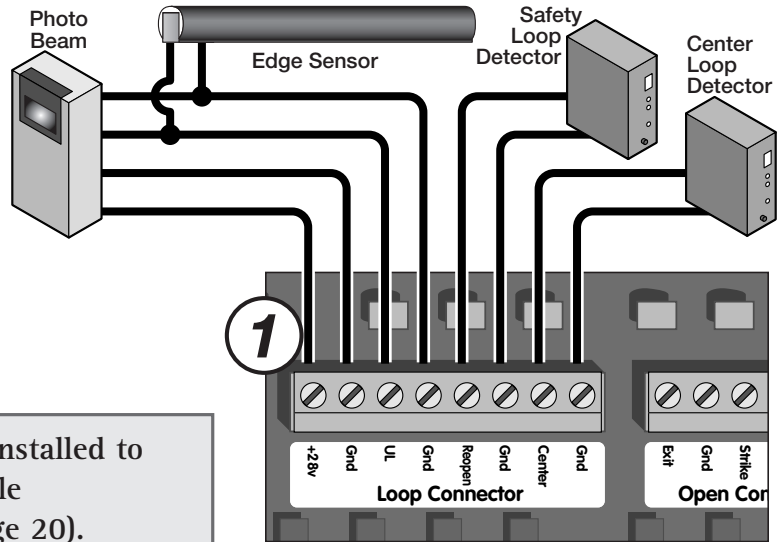
Connection Locations

Vehicle loop detectors must be installed to decrease the possibility of vehicle entrapment on the gate (see page 20).

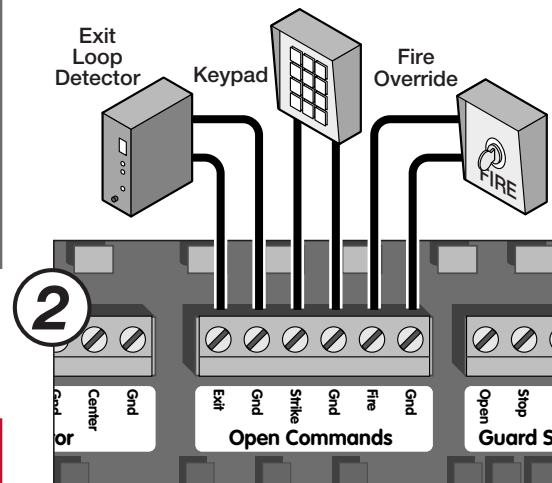
The SECONDARY ENTRAPMENT PROTECTION like the edge sensor and the photoelectric beam MUST BE PART OF EVERY SINGLE INSTALLATION to prevent pedestrian or animal entrapment (see pages 6 and 7).

The edge sensor and/or the photoelectric beam must be UL325 compliant devices.

## Safety Connections



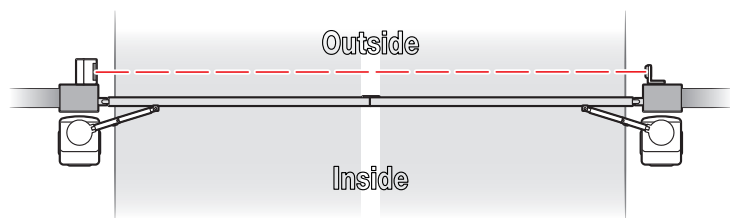
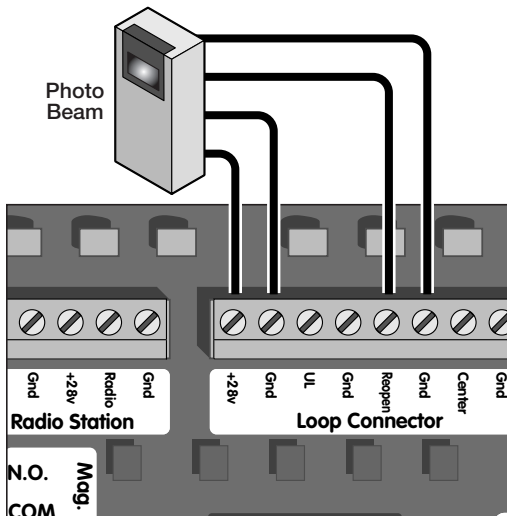
## Open Commands



## Reopen Photo Beam

Note: Installing the photo beam in this way, allows the gate to re-open all the way upon obstruction of the photo-beam.

As an alternative to the Outside Reopen Loop, a photo beam unit can be used as shown.





# ACCESSORY CONNECTIONS

## Radio Receiver

When connecting the Radio Receiver carefully verify the proper connections.

The maximum voltage that the control board provides for external accessories is the maximum voltage of the battery, which is about 28 volts.

In the event of an electrical short in the power to the accessories, the board will protect itself by shutting down and will remain shut down until the short is corrected.

The control board provides two modes of operation that a radio receiver can control the gate:

### **Open-Stop-Close**

1. By having the radio receiver connected as illustrated and with the Hold Open Timer OFF (see page 27):

Every command of the radio transmitter will control the gate as follow:

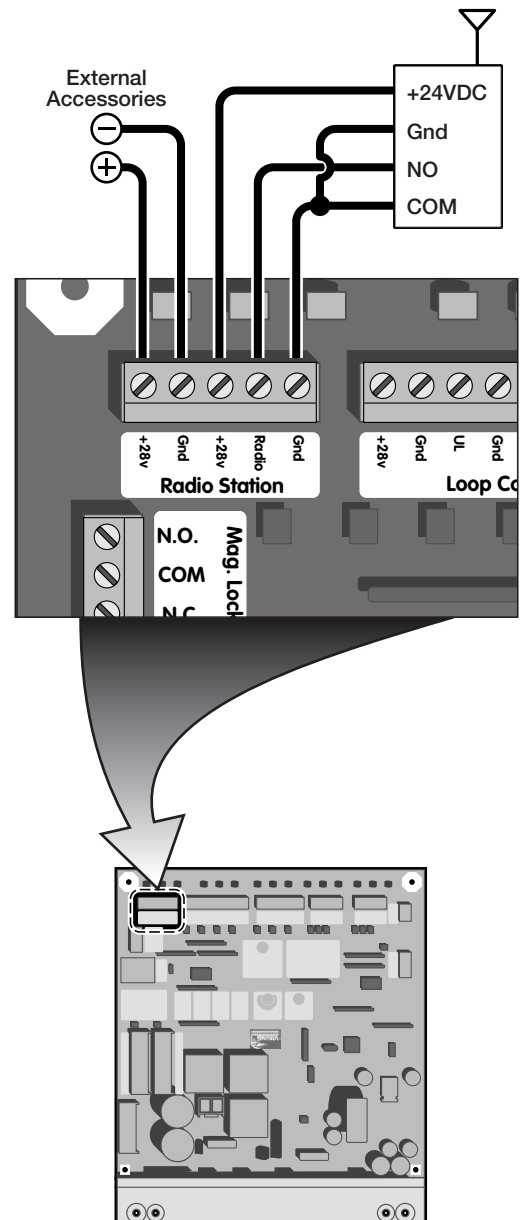
- a) First command opens the gate,
- b) Second command stops the gate and
- c) Third command closes the gate
- d) Any subsequent commands will continue in the same order to control the gate.

This type of configuration is not recommended for a commercial installations.

### **Open Only**

2. By having the radio receiver connected as illustrated and with the Hold Open Timer ON (see page 27):

Each command of the radio transmitter is ALWAYS AN OPEN COMMAND to the gate.

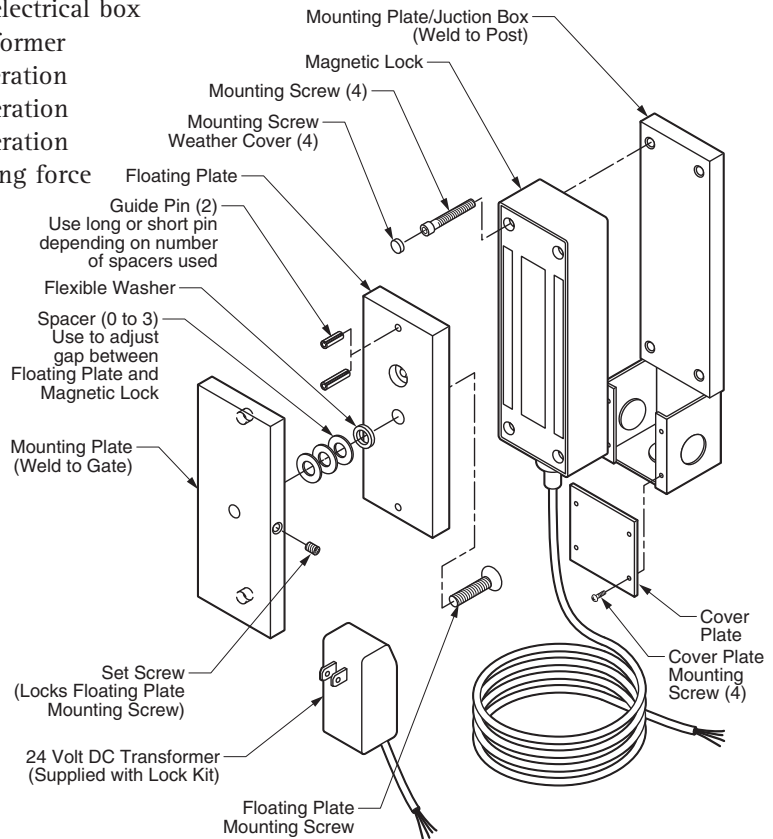
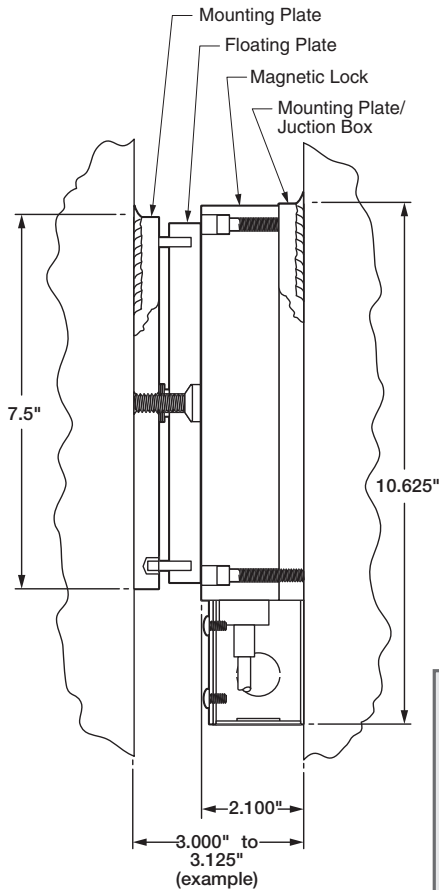




# VIKING ELECTROMAGNETIC LOCK

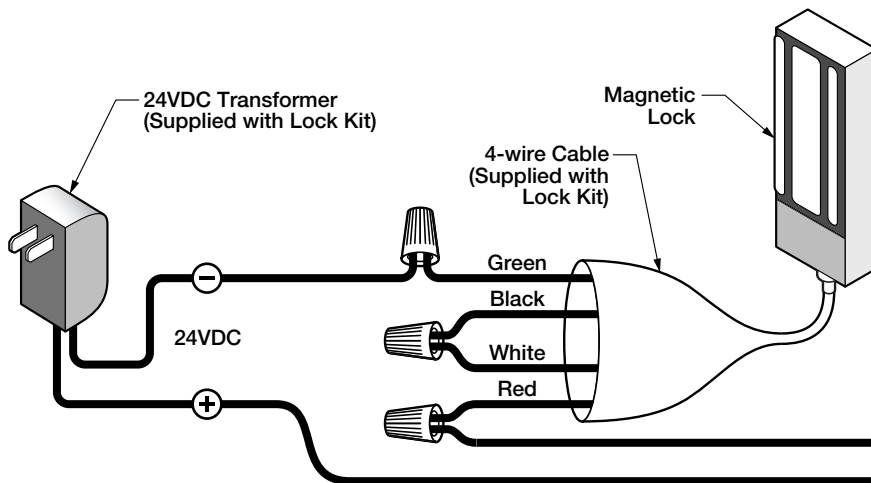
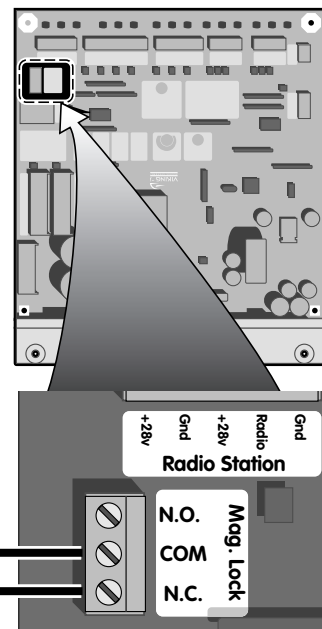
## Standard Features

- Mounting base with electrical box
- 24VDC Plug-in transformer
- 12VDC or 24VDC operation
- 500mA at 12VDC operation
- 250mA at 24VDC operation
- 1300 pounds of holding force



External supply for the magnetic lock must be provided. This will prevent rapid drainage of the battery in the event of power failure.  
Relay Contact 10A-250VAC

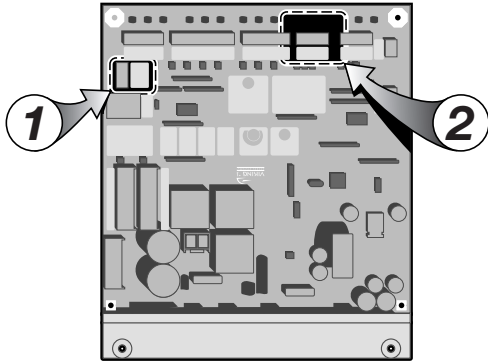
### Connection Location



This Magnetic Lock is an **OPTIONAL ACCESORY** available from Viking Access Systems. Please order part number VA-MAG13.



# ACCESSORY CONNECTIONS



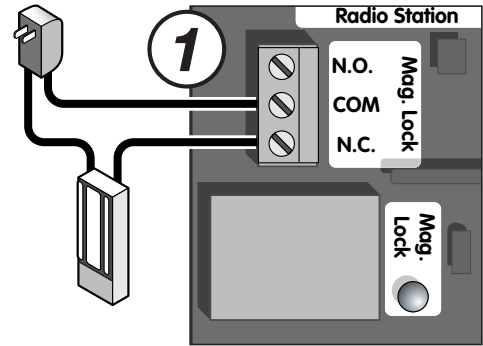
Connection Locations

Viking Access Systems can supply an excellent Magnetic Lock unit (part number VA-MAG13). See page 24 for more details.

## Magnetic Lock

External supply for the magnetic lock must be provided. This will prevent rapid drainage of the battery in the event of power failure.

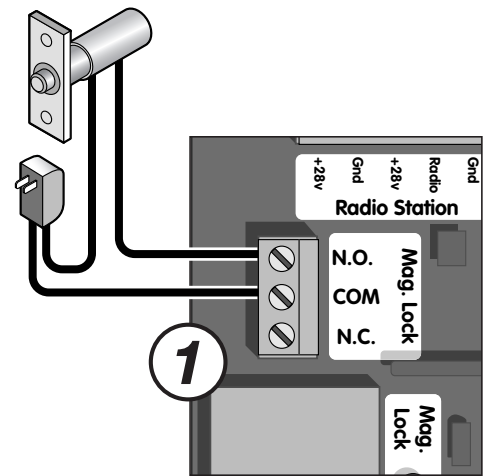
Relay Contact 10A-250VAC



## Solenoid Connection

External supply for the solenoid connection must be provided. This will prevent rapid drainage of the battery in the event of power failure.

Relay Contact 10A-250VAC

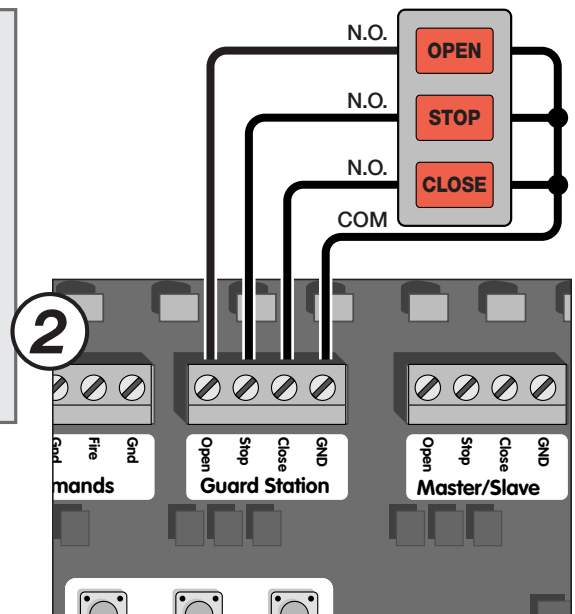


## Guard Station

The guard station provides control of the gate operator to open, stop and close the gate.

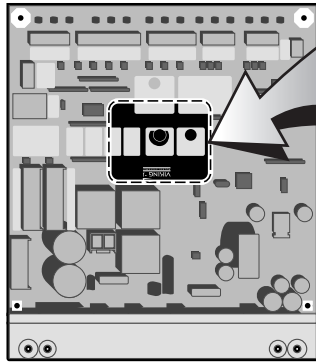
All three switches must be Normally Open type of switch, and can share the same common (ground).

Place the control switch box within sight of the gate, away from moving parts of the gate and out of reach of children.



# SPECIAL FEATURES

## Intelligent Obstruction Sensor (Primary Entrapment Protection)



Trim Pot Location



The Obstruction Sensor detects obstructions in the path of the traveling gate. The Trim Pot for the Obstruction Sensor adjusts the sensitivity level that triggers the Sensor.

When the Obstruction Sensor detects an obstruction it will:

1. Stop the gate's movement and reverse it momentarily.
2. Bring the gate to a resting position.
3. Disable the Hold Open Timer feature until the Gate Operator receives a new command.

If another obstruction is detected before the gate reaches either limit it will:

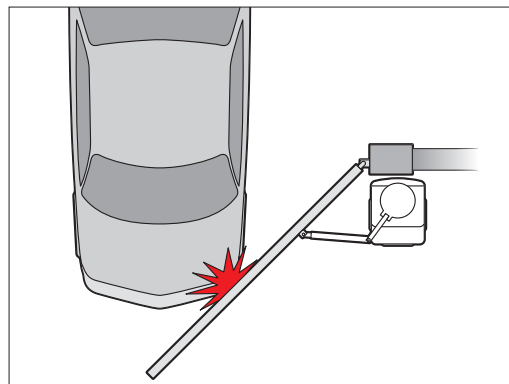
1. Stop the gate's movement.
2. Bring the gate to a resting position.
3. Disable the Gate Operator.

UL325 standard requires an audio alarm to go off after two consecutive entrapment events sensed by the Inherent Entrapment Protection of the Gate Operator.

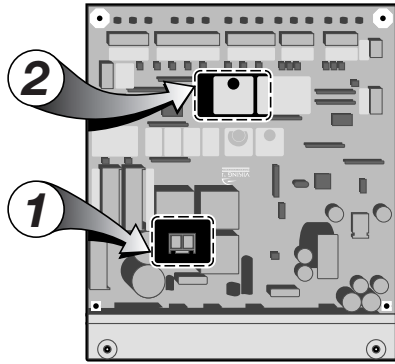
The audio alarm will sound for a period of 5 minutes or until the "Stop" Button is pressed (see page 8 for remote installation of a "Stop" Button).

Turning the Trim Pot clockwise increases the sensitivity.

Turning the Trim Pot counter-clockwise decreases the sensitivity.



# SPECIAL FEATURES



Connection Locations

## Fail Safe/Fail Secure Operation

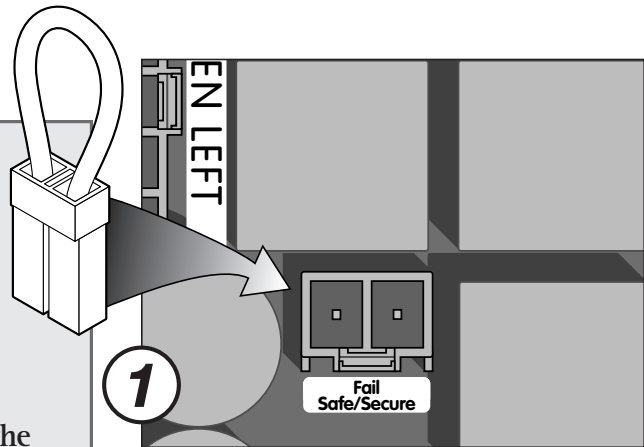
The gate operator contains a unique design that allows the user to move the gate manually in case of power failure.

### Fail Safe:

By removing the wire-jumper plug from the “Fail Safe/Secure” connector:  
The gate can be move manually with relative low amount of force.

### Fail Secure:

By inserting the wire-jumper plug into the “Fail Safe/Secure” connector:  
The gate can still be move by hand with relative high amount of force.

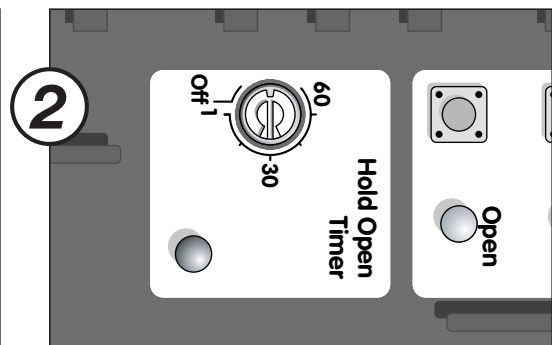


## Hold Open Timer

The Hold Open Timer function holds the gate at the open position for a predetermined amount of time, prior to closing automatically. Set the Timer to the desired time, from 1 to 60 seconds.

If this feature is not needed, turn the Trim Pot clockwise to the “off” position.

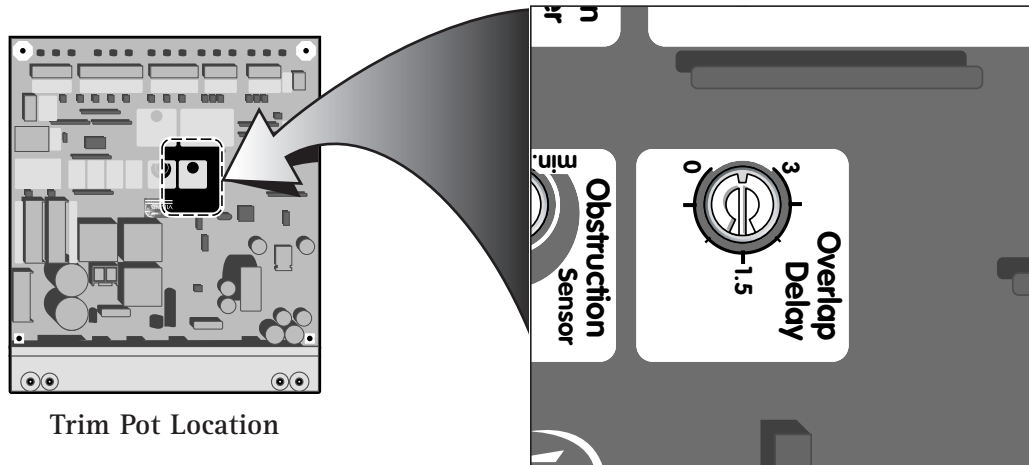
Note: The Hold Open Timer affects the “radio receiver command” and the sequence of operation for the gate (see page 23).



# SPECIAL FEATURES

## Gate Overlap Setting

Setting the Overlap Delay Pot to “0” will cause the master and the slave units to open and close at the same time

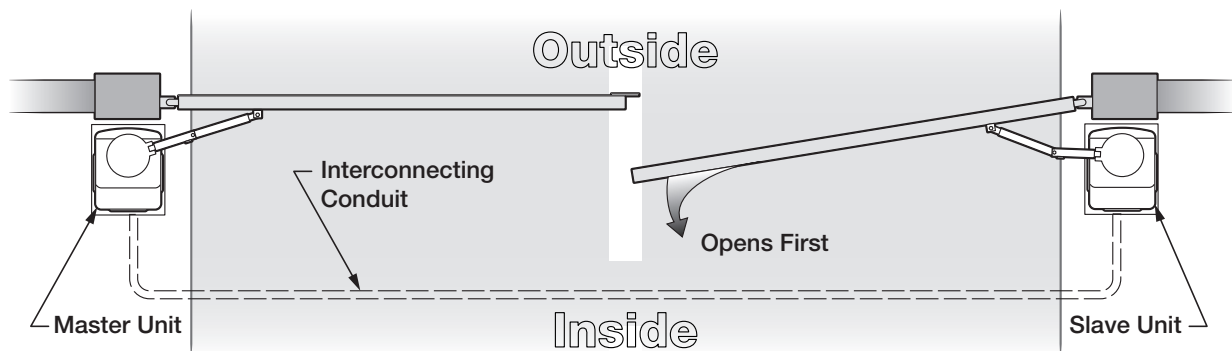


Setting the Overlap Delay Pot to any value other than zero will cause the master unit to delay in opening.

The time delay can be set for up to 3 seconds.

The Master Board sets the overlap delay for the system.

The Slave Board must have its overlap delay set to zero. This setting prevents conflict of commands between master and slave control boards.

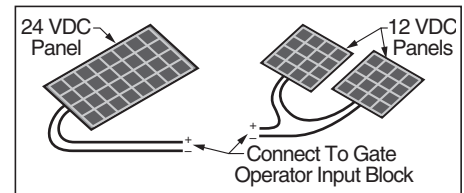


# SOLAR PANEL INSTALLATION

## For Viking Vehicular Gate Operators

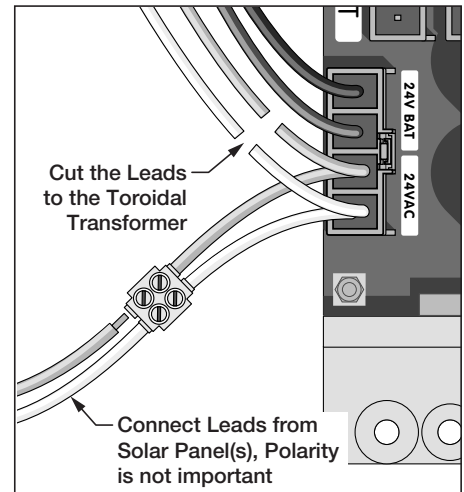
### STEP 1

Use a 24V solar panel or two solar panels of 12V in series with a total capacity of 40 Watts..



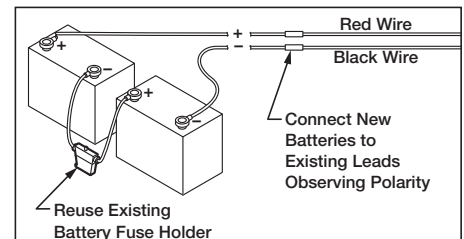
### STEP 2

Connect the solar panel cables to the power harness as shown. Make sure you cut the wires coming from the toroidal transformer.



### STEP 3

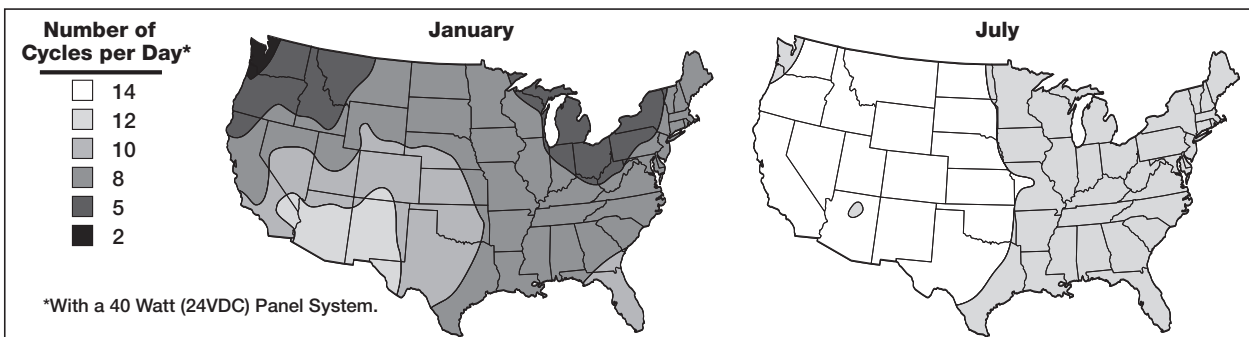
Replace the existing batteries with a battery pack of 33Ahr or greater.



### STEP 4

Refer to the maps provided to get an idea about the number of cycles the gate will be operated per day. This figure is for a single gate operator with just:

- One Radio reiver,
- One low voltage low current loop detector and
- One low voltage, low current photo cell



### NOTE -

- Remember that the sun is your only source of energy.
- The greater capacity of the batteries, the longer the system will operate on cloudy days.
- If more specific information is needed, please consult with Viking Access Systems. For more information regarding solar energy refer to <http://www.nrel.gov>.

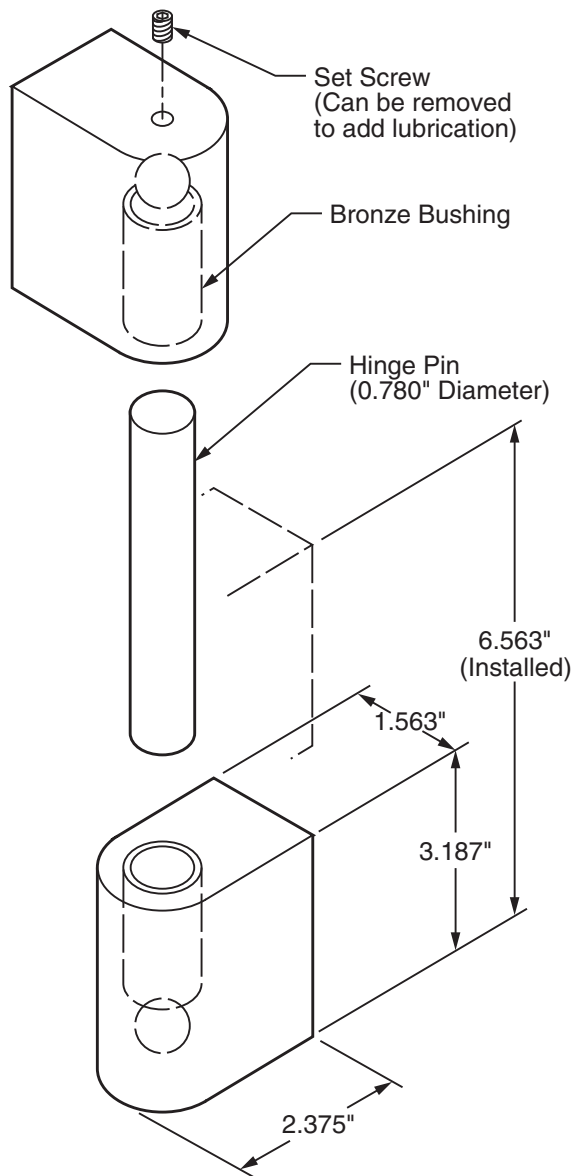




These Hinges are **OPTIONAL ACCESORIES** available from Viking Access Systems. Please order part number VA-HD.

### Standard Features

- Self-lubricating oil impregnated bronze bushing
- Port for adding a Zirk fitting
- 3000 lbs. capacity per pair
- Heat-treated stainless steel pin





# TROUBLESHOOTING

## Gate does not run – Motor Sensor indicator comes ON

Check all motor connections to be fully engaged. Refer to page 15.

Check the 15 Amp fuse in the control board.

Check that the reset switch is set in the “Reset” position.

## Gate does not run – Motor Sensor indicator is OFF

Check all motor connections to be fully engaged. Refer to 15.

Check that limit switches are connected to the common and the normally close position refer to page 17.

Check that the stop command is not active. Refer to page 8 and 25.

Check that the UL command (photo beam and/or edge sensor) is not active. Refer to page 6, 7 and 22.

Check that the vehicular loop detectors are working properly. Refer to page 20, 21 and 22.

Check that the radio command is not active. Refer to page 23.

Ensure that you external accessories are working properly.

Check the 4 Amps fuse in the control board.

Ensure that you power cables are adequate in voltage and properly connected. Refer to page 15.

## Gate does not run – Power failure

Check the 15 Amp battery fuse. Refer to page 18.

Check the battery connections and cables. Refer to page 14 and 18.

Check the voltage of the battery.

## Gate does not run – Obstruction sensor ON and audio alarm is SOUNDING

Ensure that the gate path is clear of obstructions.

Note: To stop the audio alarm, use the stop command. Refer to page 8 and 25.

Adjust the trim pot of the obstruction sensor. Refer to page 26.

## Gate runs, stops and reverse momentarily – Obstruction sensor ON and audio alarm OFF

Ensure that the gate path is clear of obstructions.

Check for proper functionality and lubrication of the gate and hardware (hinges and the like).

Adjust the trim pot of the obstruction sensor. Refer to page 26.

## Gate ignores the limit switches

Check that the open limit switch and close limit switch are in the corresponding place. Refer to page 16.

Check that all motor cable connections, junctions and extensions are properly connected and color-coded. Refer to 15.

Ensure that the motor cable is away from sources of electrical interference, such as

- Electric motors
- Electric fences
- Power lines.

Check that the limit switch is not faulty.

Check that wires to the limit switch are not shorted.

Note: To minimize effects cause by electrical interference use twisted pairs of cables with the shield grounded.



# TROUBLESHOOTING

## Gate does not open or close

Check all motor connections to be fully engaged. Refer to page 15.

Check that limit switches are connected to the common and the normally close position. Refer to page 17.

Check that the stop command is not active. Refer to page 8 and 25.

Check that the UL command (photo beam and/or edge sensor) is not active. Refer to page 6, 7 and 22.

Check that the vehicular loop detectors are working properly. Refer to page 20, 21 and 22.

Check that the radio command is not active. Refer to page 23.

Ensure that you external accessories are working properly.

## Automatic close does not function

Check that the trim pot of the hold open timer is set to the proper time delay. Refer to page 27.

Note: Hold open timer closes the gate automatically once the gate reaches the limit open. The time delay to close is set by the trim pot. To turn this system off turn the trim pot all the way clockwise.

## Gate opens in the opposite desired direction

Verify your motor cable is connected to the proper connector. Refer to page 15.

## “Open” and “Close” LEDs blinking

Check all the limit switch connections. Check that both limit switches are not being actuated at the same time. Refer to page 17.

Check that both limit switches are not disconnected. Refer to page 17.

## On a Master/Slave installation, one gate runs in the opposite direction

Check the motor and limit switch wiring. Refer to pages 15 and 16.

Verify that one unit is connected as open-left and one unit is connected as open-right. Refer to page 15.



# TROUBLESHOOTING

## Gate opens after few second delay

Set the overlap delay trim pot to 0. Refer to page 28.

Note: Overlap trim pot is normally recommended to use in overlapping gates. Refer to page 28.

## Gate opens. Closes or stops on its own

Ensure that the key for manual release is in the lock position. Refer to page 7.

Make sure that the 'Charger' LED is on, indicating that there is AC power.

Check that your wires from your accessories are:  
a) Not shorting together  
b) Not shorting a power line  
c) Not shorting to metal or earth ground.

## F-1 unit runs slower than normal

Set the overlap delay trim pot to 0. Refer to page 28.

Note: Overlap trim pot is normally recommended to use in overlapping gates. Refer to page 28.

## 'Charger' LED off. Gate does not run - alarm sounds upon any input command

Check the 4 Amp fuse on the control board.

Check the 3 Amp fuse on the EMI board. Refer to page 14.

Make sure the incoming AC line is properly connected. Refer to page 14.

Check the incoming high voltage power supply.

Check the proper selection of power supply (120/220 VAC). Refer to page 14.

Verify the EMI board by reading high voltage across the (4) blue and red wires at the terminal block connections.

## Battery voltage reads zero or very low

Ensure the batteries are connected as follows:

- a) Left battery - Black terminal connected to the black wire from the harness (jacketed wire)
- b) Left battery - Red terminal connected to the red wire from fuse holder
- c) Right battery - Black terminal connected to the red wire from fuse holder
- d) Right battery - Red terminal connected to the red wire from the harness (jacketed wire)



UL325 and UL991 Listed by Underwriter Laboratories (UL)

Accessible manual and electrical emergency releases.

Fail-Safe option sets the gate to automatically transfer to a fail-safe mode in the event of a power failure, allowing the gate to be pushed open without the use of special knowledge of the equipment.

Fail-Secure option sets the gate to mechanically lock in the event of a power failure, allowing no manual movement without the use of the manual release.

Elegant design, appealing to any architectural project.

Powder coated aluminum chassis.

Opening up to 120°.

Operation speed of 13 to 16 seconds per 90°.

100% duty cycle under very wide temperature range.

Very low power consumption.

300 cycles of operation on backup battery (600 lb. gate and 12' length).

Intelligent speed control with smooth start and stop, self-adjust system.

Modulated speed regulator prevents exceeding operating speed that may reduce the service life of the gate operator and/or installation.

Intelligent obstruction detection with adjustable sensitivity.

Overlap delay that holds one gate momentarily by an adjustable time while the other gate is operating (Master/Slave installation with overlap gates).

Built-in protection against lightning strikes or similar electrical surges  
Inherent overload protection in the regulated power supply for external accessories with multiple devices of protection.

Modular connectors for easy installation.

Solar panel and low voltage wiring compatibility.

LED indicators for verification of operation.



Viking Access Systems  
T 800.908.0884 • F 949.753.1640  
631 Wald - Irvine, CA 92618

[vikingaccess.com](http://vikingaccess.com)