

# Price Book

January 2018

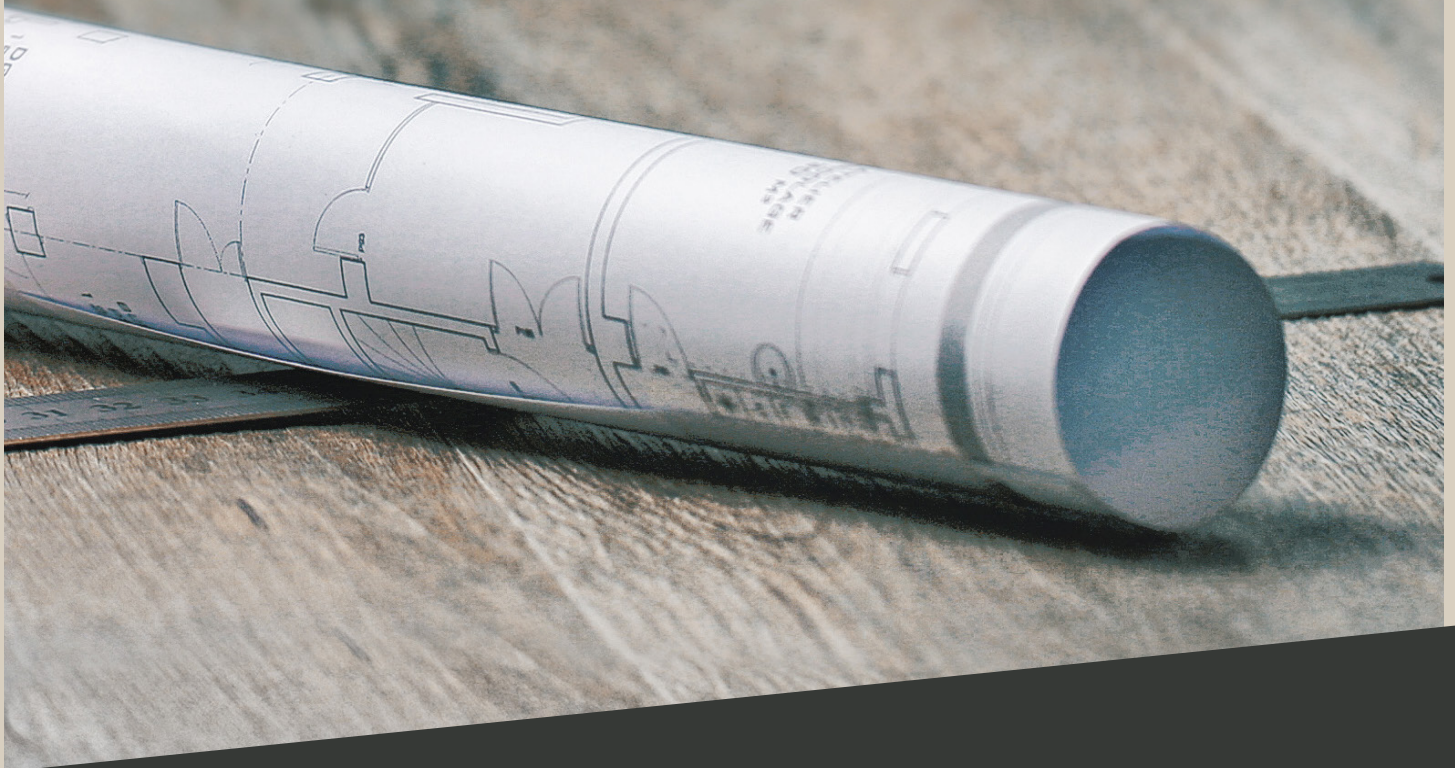

**Warmup**<sup>®</sup>

The world's **best-selling** floor heating brand™

# What floor heating product should I use?



I'm interested in a Floor Heating System

Under Tile or Stone

Over a Concrete Slab

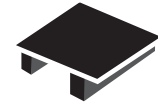
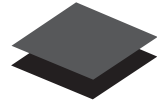

Over Plywood or Concrete Boards

Under Laminate or Floating Wood

Under Solid Hardwood or Bamboo

Under Carpet





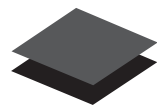



Under Sheet Vinyl or LVTs

Over a Concrete Slab



Over Plywood or Concrete Boards

In a concrete slab

			PAGE
		<b>NEW</b> Use NADCM-PRO Cable at 2" spacing with Self-Leveler.	10
		Use NADWM mats, with WIB insulation boards.	16, 27
		Use NADWM mats	16
		<b>NEW</b> Use NADCM-PRO Cable and Membrane at 3" spacing.	10
		Use FOIL over WIU insulation.	20, 27
		<b>NEW</b> Use NADCM-PRO Cable with 3" or 4" spacing using the sleepers method.	10
		Use FOIL between the pad and the carpet.	20
		<b>NEW</b> Use NADCM-PRO Cable at 2" spacing with Self-Leveler.	10
		Use NADWM mats with WIB insulation boards.	16, 27
		<b>NEW</b> Use NADCM-PRO Cable and Membrane at 3" spacing.	10
		Use WODH cable on wire mesh at 4" spacing.	24

# Who is Warmup

More than 23 years ago, Warmup set out to become the world's most trusted provider of innovative underfloor heating solutions.

Our strategy focuses on the creation of the best products, best service, best warranties and the harnessing of the most advanced information on product safety and capabilities through proprietary research & development.

The combination of heating wire with fluoropolymer coating (on the inner wires and the outer protective jacket) and thermostats are patented, trademark protected, designed and owned by Warmup.

We now occupy a world leading position in our field, selling more than 2.1 million systems in over 70 countries.



# Getting Started with Warmup

Be the one to promote the heated floors option. Warmup offers solutions from comfort heat to primary heating. If you don't ask, they won't buy. Rest assured, we'll make it an easy process.



## Quote

In the USA: (888) 927-6333 / [ussales@warmup.com](mailto:ussales@warmup.com)

In Canada: (888) 592-7687 / [ca@warmup.com](mailto:ca@warmup.com)

FAX: (888) 927-4721

You can submit a fax or email us with anything good enough to describe your project. From a set of blueprints to a few notes on a napkin, we've seen it all. Don't be shy, send it over.

We'll complete a detailed installation plan for you within 24 hours. Just let us know whether you want a quick price over the phone, or a detailed review of your project.



## Ask

Call us. We don't have a fancy answering service, but we have real friendly people. They'll answer your questions or connect you with your local sales person right away. Email us about your project and we'll connect you straight to your local Warmup office.



## Order

Email or fax us. We're never too busy to take your order. If it's your first time, we'll get you set-up same day and make sure your order is dispatched promptly. Please note that all orders need to be in writing.

# Common Questions

## Can I cut the cable if it is too long?

NO: space the cable tighter (minimum spacing allowed: 2"). If it is still too long then you must choose a smaller size.

## Which spacing for the cable?

2": 20W/sqft

3": 14W/sqft

4": 11W/sqft

On Mats, cables are spaced at 3".

With the use of our Warmup Insulation Boards, you will reduce heat loss and improve results even at wider spacings. You will also reduce operating costs. Check page 27 for more information.

## Can I install the cable directly on top of the plywood ?

YES: wood is a natural insulator, no need of extra insulation.

Exception: if this is a non-insulated crawl space under the plywood, we would recommend the use of insulation boards prior to the installation.

## Can I connect more than one cable to the thermostat ?

YES: if the total load of the cables does not exceed 15 amps.

## Can I connect one cable to another (series connection) ?

NO: each cable must be individually connected to the thermostat (connection in parallel).

## How do you stick the insulation boards to the concrete slab ?

You can stick the insulation boards to the concrete slab using regular modified or pre-mixed thinset. We recommend a 1/4 or 3/8" trowel.

## Should I use self-leveler or thinset ?

While you can technically thinset and tile directly over the mats and cables, we do not recommend it as it is not practical. There is no better option between a scratch coat, thinset or a thin self-leveler pour. Select the best option for your floor covering installation.

## Can I install a wooden floating floor directly on top of the cable ?

NO: cable must be embedded in thinset or self-leveling compound. Once dry, the floating wooden floor will be installed on top. Alternatively, select the FOIL heating mats which can be installed without thinset (p.20).

## Can I use any thinset mortar ?

We highly recommend the use of polymer-modified adhesives, also known as "modified thinset". Both self-leveling compounds and modified thinsets are suitable with embedded products.

## How do I check if the cable is working ?

The only way to see if the cable is going to work and is not damaged is to use an ohmmeter to check the resistance between the heating conductors matches what it should be in the manual or on the box. Need also to check and make sure that there is no resistance to ground.



More information on

[warmupedia.warmup.com](http://warmupedia.warmup.com)

Warmupedia documents installation tips and troubleshooting guides for all Warmup products.



# Warmup General Terms

## PAYMENT TERMS

Orders placed prior to credit approval will be subject to full prepayment. Warmup standard payment terms are net 30 days from date of invoice. Special terms and conditions can be negotiated and discussed with your Key Account Manager. A credit application with signed business terms must be on file with Warmup. Please include a copy of your Resale Certificate.

## REMIT PAYMENTS

In the USA:

Warmup, Inc  
52 Federal Rd, Unit 1F  
Danbury, CT, 06810

In Canada:

Warmup, Inc  
C/O TH1067  
PO Box 4283  
Postal Station A  
Toronto, ON, M5W 5W6

Shipping and handling will be invoiced with the products purchased. All standard orders carry a flat \$25 freight charge and are shipped UPS Ground. Expedited shipments are invoiced 'at cost' based on Warmup's discounted rate. Oversized SKU's carry additional costs such as WIB insulation boards (\$25 each) and DCM-PRO membrane boxes and rolls (\$25 each). All palletized shipments are invoiced at \$250/pallet flat fee instead.

## RETURNS

Returns, in resalable condition, are allowed within 30 days of purchase for a full refund. You must request an RGA from Warmup. Returns received without RGA cannot be refunded. After 30 days of purchase, or after expiration of the RGA, Warmup will only issue credit notes on future orders and apply a 20% re-stocking fee.

## ORDERS MUST BE SUBMITTED IN WRITING

Fax: (888) 927-4721

In the USA: [us@warmup.com](mailto:us@warmup.com)

In Canada: [ca@warmup.com](mailto:ca@warmup.com)

Orders placed before 1:30PM (EST) will be shipped same-day, UPS. Orders placed after the deadline will be shipped promptly the following business day.

## ONLINE POLICY

The Warmup brand is exclusive to established and approved brick & mortar resellers. The Warmup products cannot be sold online through third-party resellers such as Amazon or eBay. Warmup resellers may post product on their websites following the MAP policy. To obtain a copy and offer our products on your company website, please contact [us@warmup.com](mailto:us@warmup.com).

For complete and up-to-date Warmup Inc. Terms and Conditions, visit [warmup.com](http://warmup.com) or [warmup.ca](http://warmup.ca).

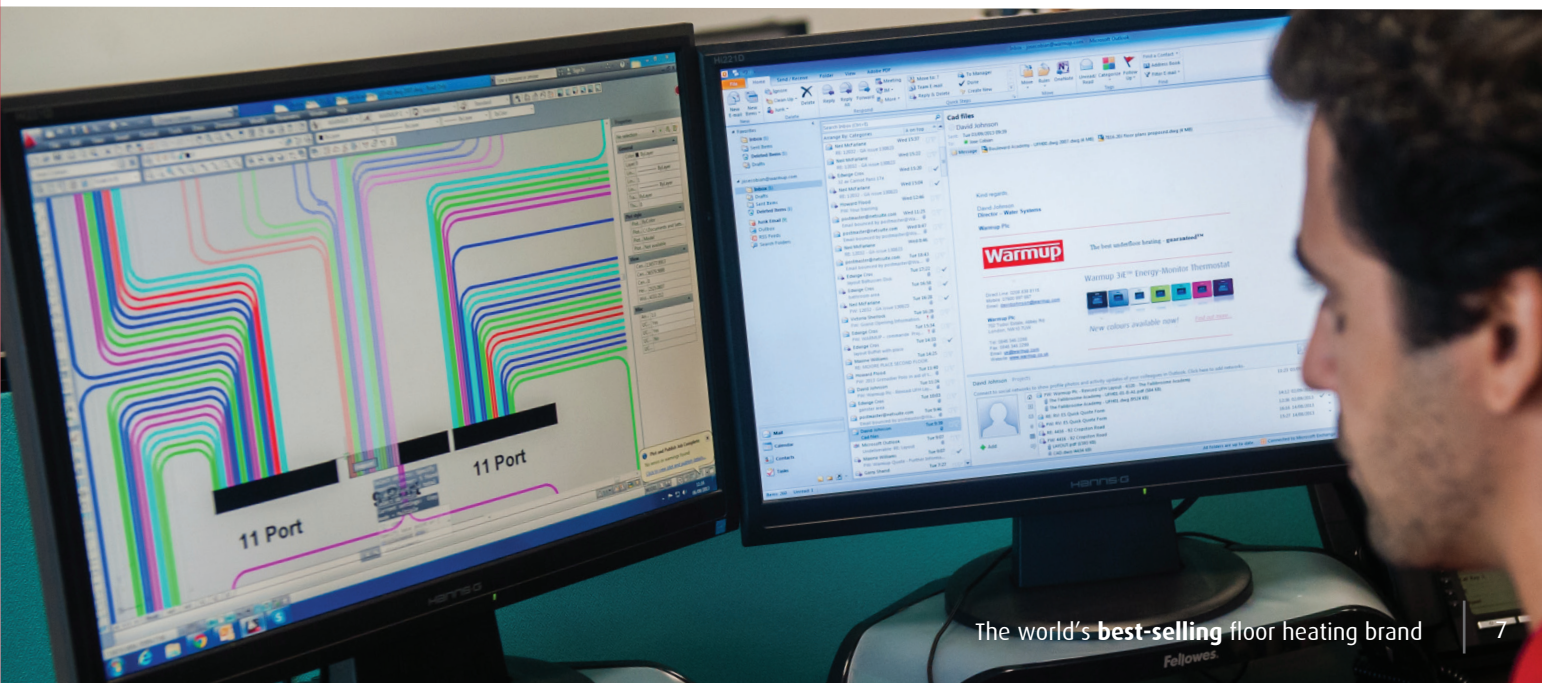

Bring warmth & comfort to  
your floors with Warmup®





Install a Warmup floor heating system to heat your whole house or to take the chill off stone and tiled floors!

Warmup can be used as the primary heat source and bring comfortable radiant heat in bathrooms, kitchens and other tiled/stone areas of the home.

Electric floor heating from Warmup is easy to specify and install. With

ready-made sizes and field-modifiable mats or cables to fit any room and layout, you are well on your way to a successful project. Warmup provides all the assistance, controls and optional insulation to make your heated floors cost-efficient to operate. With the thinnest profile wire and the fastest heat-up times, it is no surprise Warmup is the world's best-selling electric floor heating brand.

# DCM-PRO Cable and Uncoupling Membrane

## Use under tile & stone, LVT's and glued-down wood floors

The Warmup DCM-PRO Cable is a custom designed cable compatible with all uncoupling membranes.

The cable can be spaced at 3 or 4" for the highest flexibility in heat outputs, from Comfort Heating to Primary Heating.

It is guaranteed 30-years.

Even better results when used with Warmup 4iE Smart thermostat (page 26) and lowest consumption cost when installed with 1/4" Warmup Insulation Boards (page 27).

Thickness	3/16" (4.5mm - +/- 0.2mm)
Output	Varies with spacing from 11w/sqft to 20w/sqft
Construction	Multi-stranded, dual wire
Inner insulation	ETFE
Outer jacket	PVC
Ground braid	85% min copper
Cold lead	10ft (3m) long, 2 core braided

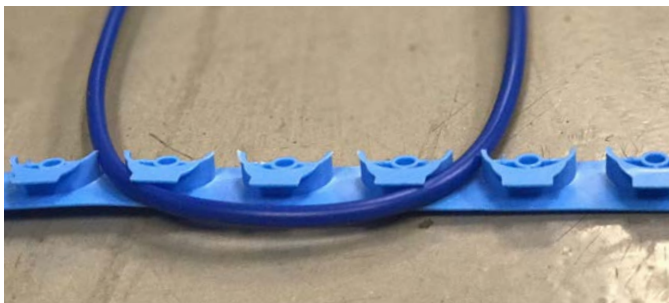

Plastic fixing strips (PLG-DCM-12) holding the DCM-PRO Cable.

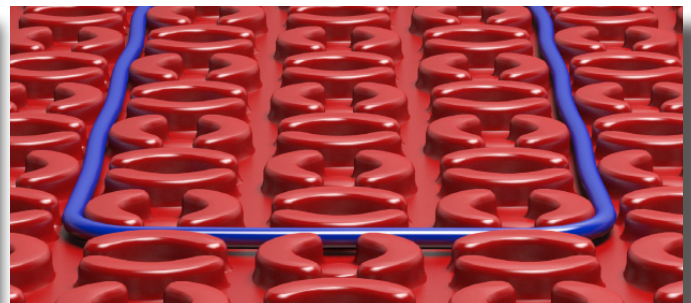

DCM-PRO Cable fitted in the DCM-PRO Membrane.



Code	Length (ft)	Resistance (Ω)	Amps	Membrane Spacing			Canada	USA
				2 pegs	3 pegs	4 pegs		
				Cable spaced at gives sq ft coverage of				
NADCM-C-120-65	16.7	221.5	0.5	3	5	7	\$180.00	\$157.00
NADCM-C-120-130	33.1	110.8	1.1	7	10	13	\$209.00	\$181.00
NADCM-C-120-195	49.9	73.8	1.6	10	15	20	\$235.00	\$204.00
NADCM-C-120-260	66.3	55.4	2.2	13	20	27	\$266.00	\$231.00
NADCM-C-120-325	83.0	44.3	2.7	17	25	33	\$293.00	\$254.00
NADCM-C-120-390	99.4	36.9	3.3	20	30	40	\$303.00	\$263.00
NADCM-C-120-525	132.9	27.4	4.4	27	40	53	\$356.00	\$309.00
NADCM-C-120-655	166.0	22.0	5.5	33	50	67	\$409.00	\$355.00
NADCM-C-120-785	199.1	18.3	6.5	40	60	80	\$459.00	\$399.00
NADCM-C-120-920	232.3	15.6	7.7	47	70	93	\$511.00	\$444.00
NADCM-C-120-1050	265.4	13.7	8.8	53	80	107	\$565.00	\$491.00
NADCM-C-120-1180	298.6	12.2	9.8	60	90	120	\$619.00	\$538.00
NADCM-C-120-1315	331.7	11.0	11	67	100	133	\$670.00	\$582.00
NADCM-C-120-1445	364.8	10.0	12	73	110	147	\$723.00	\$628.00
NADCM-C-120-1575	398.0	9.1	13.1	80	120	160	\$776.00	\$674.00
NADCM-C-240-325	83.0	177.2	1.4	17	25	33	\$293.00	\$254.00
NADCM-C-240-390	99.4	147.7	1.6	20	30	40	\$303.00	\$263.00
NADCM-C-240-525	132.9	109.7	2.2	27	40	53	\$356.00	\$309.00
NADCM-C-240-655	166.0	87.9	2.8	33	50	67	\$409.00	\$355.00
NADCM-C-240-785	199.1	73.4	3.3	40	60	80	\$459.00	\$399.00
NADCM-C-240-920	232.3	62.6	3.9	47	70	93	\$511.00	\$444.00
NADCM-C-240-1050	265.4	54.9	4.5	53	80	107	\$565.00	\$491.00
NADCM-C-240-1180	298.6	48.8	5	60	90	120	\$619.00	\$538.00
NADCM-C-240-1310	331.7	44	5.6	67	100	133	\$670.00	\$582.00
NADCM-C-240-1640	414.7	35.1	7	83	125	167	\$800.00	\$695.00
NADCM-C-240-1970	497.7	29.2	8.4	100	150	200	\$915.00	\$871.00
NADCM-C-240-2300	580.7	25.0	9.8	117	175	233	\$1,006.00	\$958.00
NADCM-C-240-2630	663.4	21.9	11.2	133	200	266	\$1,044.00	\$994.00
NADCM-C-240-2955	746.4	19.5	12.6	150	225	300	\$1,118.00	\$1,064.00
NADCM-C-240-3240	829.4	17.8	13.5	167	250	333	\$1,229.00	\$1,170.00

Code	Optional Insulation	Canada	USA	See Page
WIB-4X2-1/4*	6 insulation boards per box. Total coverage 48 sq ft - board size: 2'x4'x1/4"	\$219.00	\$219.00	27

\* for mounting accessories, see page 27

Code	Thermostats	Max Load	Canada	USA	See Page
TEMPO	Programmable thermostat	15A	\$165.00	\$145.00	31
4iE-03BL	Warmup 4iE Thermostat, 120V/240V with sensor and Class A GFCI, black	15A	\$239.00	\$216.00	
4iE-03WH	Warmup 4iE Thermostat, 120V/240V with sensor and Class A GFCI, white	15A	\$239.00	\$216.00	
4iE-04BL	Warmup WiFi 4iE Thermostat, with sensor and Class A GFCI, black	15A	\$299.00	\$279.00	
4iE-04WH	Warmup WiFi 4iE Thermostat, with sensor and Class A GFCI, white	15A	\$299.00	\$279.00	

Code	Accessories	Canada	USA
M-DGMTR	The Alligator Tester - Digital Multimeter	\$23.00	\$20.00
REPAIR-INDOORS	Repair kit for 120/240V systems: REPAIR-ENDCAP, REPAIR-JOINT	\$12.00	\$10.00
DCM-SP-10K	Additional Floor Sensor for the 4iE®.	\$23.00	\$20.50
RELAY-25	General purpose 25A/240V relay used to expand the switching capability of the 4iE thermostat series. Mounts in single gang box.	\$96.00	\$80.00
PLG-DCM-12	Plastic fixing strips - Strips are 12" long with spacing available on 1" increments. Approximately 3/16" thick. Box of 40.	\$53.00	\$44.00

# DCM-PRO Membrane & Uncoupling System

Use under tile & stone, LVT's and glued-down wood floors.

The TCNA-tested DCM-PRO anti-fracture Membrane can be installed on wood and cement subfloors using any tile adhesive.

The patented DCM-PRO design allows for more adhesive to connect with

the cable thereby distributing the heat more evenly.

There is no waiting required after installation so you can begin laying the flooring immediately.

Installers can use either modified or unmodified adhesives over the membrane to suit their installation needs. The DCM-PRO Membrane can even be covered with self-levelling mortars (SLU's) to allow installation of small format tiles and other floor types such as glue-down wood and LVT's, to be laid on top of the DCM-PRO System.

The unique design of the DCM-PRO Membrane protects the cable from installation damage leading to a reduced risk of cable failures.

The membrane has been successfully tested to ANSI A118.12 standards and performed well on the Robinson test (ASTM C-627). It is the highest-rated membrane for floor heating systems.

## Features

- Under 6mm – 1/4" thick
- Rated as Anti-Fracture membrane as tested by the TCNA against ANSI A118-12
- Installs with regular or modified thinsets
- Ready to tile over
- Use any adhesives or SLU's on top
- Highest heating outputs with DCM-PRO Cable (page 10)
- Lowest running costs with 1/4" Warmup Insulation Boards (page 26)
- Smart operation with 4iE-04 Smart WiFi Thermostat (page 31)





	Code	Description	Dimensions of each sheet /roll	Canada	USA
NEW!	NADCM-M-80	Box of 10 sheets, covering 81.6sqft in total.	3'3" x 2'7"	\$244.00	\$197.00
NEW!	NADCM-M-150	Roll of membrane, covering 150 sqft in total.	3'3" x 47'2"	\$398.00	\$319.00

## Application

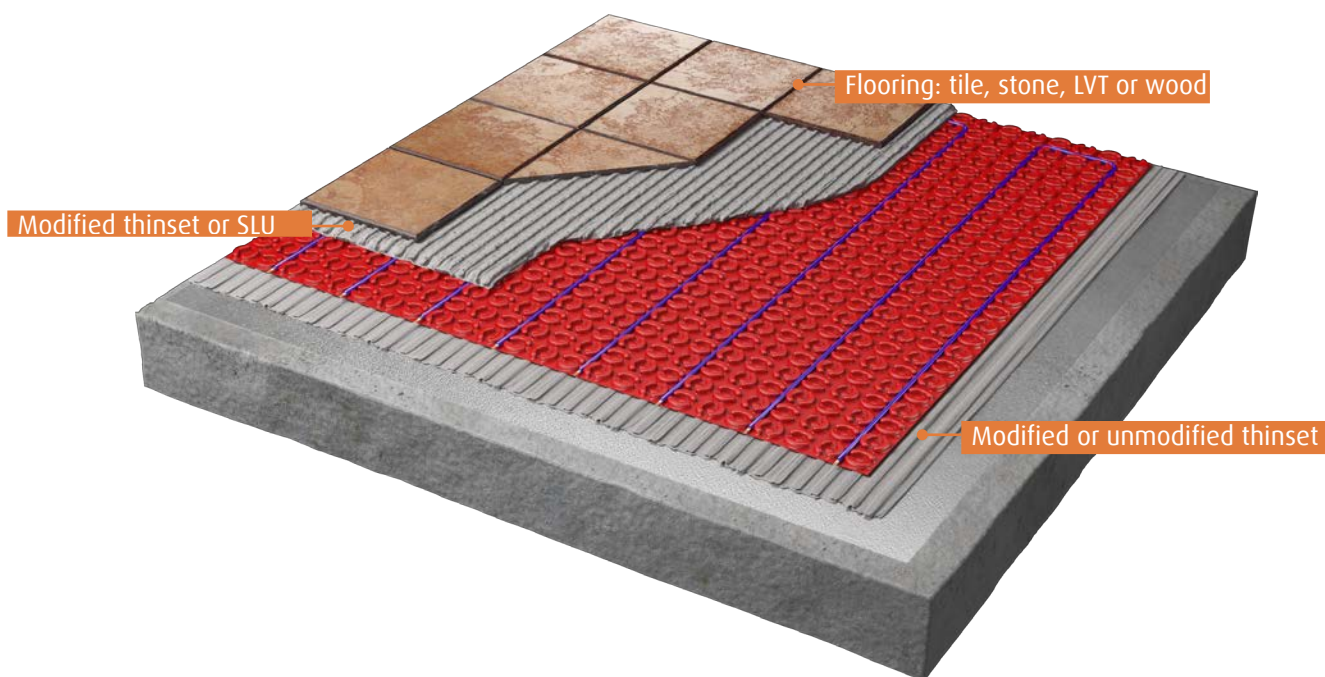

### ANSI A118.12: High Performance

The Warmup DCM-PRO showed no sign of movement at 1/8" subfloor gaps on all three tests performed by the TCNA.

It is entirely mold proof and reached over 100 PSI bond strength at the 7-day shear strength test (high performance is >50 PSI).

### ASTM C627

The Warmup DCM-PRO Membrane completed all 14 cycles with no visible damage over a wood subfloor mounted on 19" o/c beams.



Robinson Test: EXTRA HEAVY Rating

# Loose Cable System

Use under tile & stone.

The Warmup NADWS Cable System is designed for use within the adhesive layer under tiles or within a leveling compound under other floor finishes.

The variable spacing of the cable, available during design and installation, allows the system power to be tailored to the properties requirements.

The Loose Cable System is ideal for installation within small or irregularly shaped areas.

In a bathroom, the cable can be easily installed around the fixtures and within rooms with curved features, it can easily follow the contours.

The variable spacing of the cable also allows the heat output to be matched to requirements.

For regularly shaped rooms the Sticky Mat system offers a quick and precise installation alternative to the Loose Wire System.

Alternatively, for floor finishes other than tiles, the FOIL heating System offers a completely dry construction that does not require a leveling compound, thinsets or adhesives.

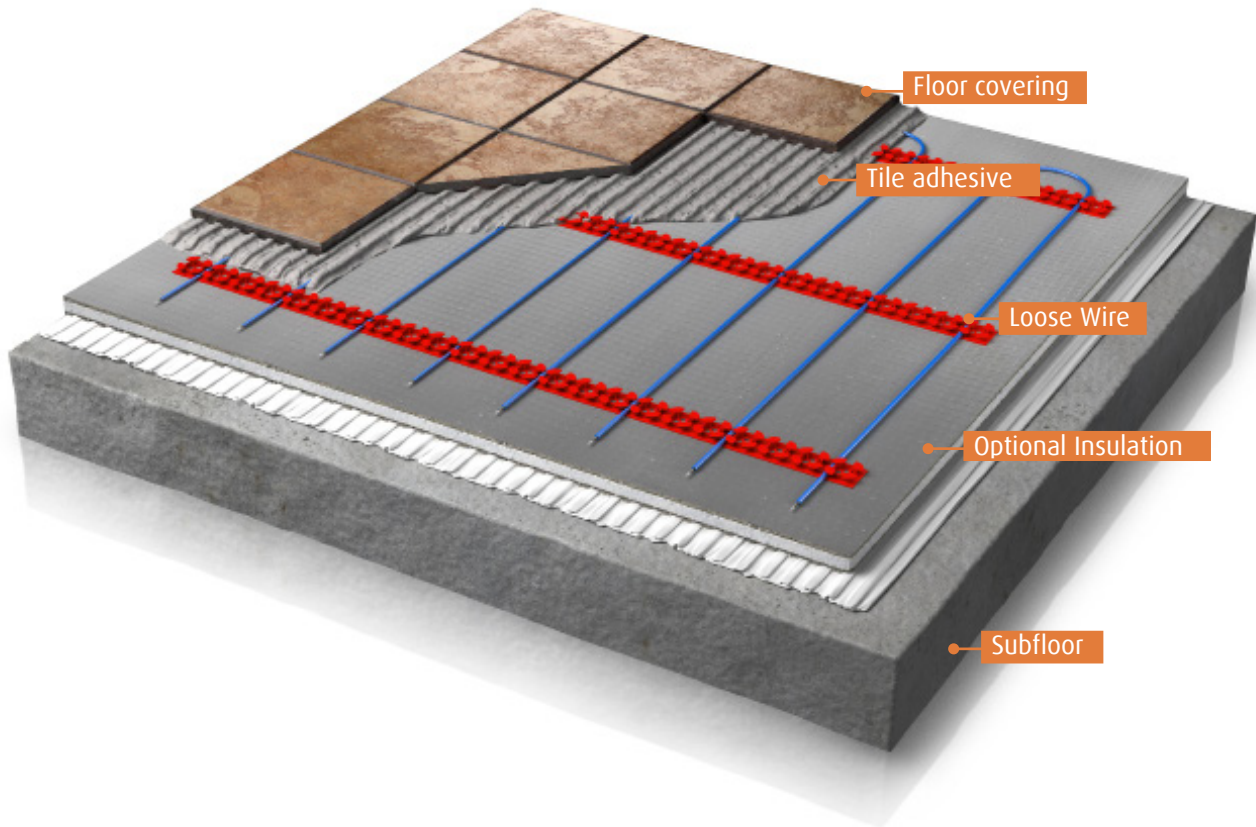



Code	Cable spaced at			Length (ft)	Wattage	Amps	Resistance (Ω)	Canada	USA
	2"	3"	4"						
NADWS-120-140	6	10	13	40	140	1.2	102.9	\$208.00	\$196.00
NADWS-120-210	10	15	20	60	210	1.8	68.6	\$233.00	\$219.50
NADWS-120-280	13	20	27	80	280	2.3	51.4	\$259.50	\$244.50
NADWS-120-350	16	25	33	100	350	2.9	41.1	\$295.00	\$278.00
NADWS-120-420	20	30	40	120	420	3.5	34.3	\$331.00	\$312.00
NADWS-120-560	26	40	53	160	560	4.7	25.7	\$402.50	\$379.00
NADWS-120-700	33	50	67	200	700	5.8	20.6	\$457.50	\$430.50
NADWS-120-840	40	60	80	240	840	7.0	17.1	\$510.50	\$480.00
NADWS-120-1050	50	75	100	300	1050	8.8	13.7	\$592.00	\$557.50
NADWS-120-1260	60	90	120	360	1260	10.5	11.4	\$688.50	\$648.00
NADWS-120-1540	73	110	147	440	1540	12.8	9.4	\$771.00	\$725.50
NADWS-120-1620	80	120	160	480	1620	13.5	8.9	\$830.50	\$781.50
NADWS-240-350	16	25	33	100	350	1.5	164.6	\$295.00	\$278.00
NADWS-240-560	26	40	53	160	560	2.3	102.9	\$402.50	\$379.00
NADWS-240-700	33	50	67	200	700	2.9	82.3	\$457.50	\$430.50
NADWS-240-1050	50	75	100	300	1050	4.4	54.9	\$592.00	\$557.50
NADWS-240-1260	60	90	120	360	1260	5.3	45.7	\$688.50	\$648.00
NADWS-240-1540	73	110	147	440	1540	6.4	37.4	\$771.00	\$725.50
NADWS-240-2100	100	150	200	600	2100	8.8	27.4	\$949.50	\$893.00
NADWS-240-2520	120	180	240	720	2520	10.5	22.9	\$1,068.00	\$1,005.50
NADWS-240-3080	146	220	293	880	3080	12.8	18.7	\$1,305.50	\$1,229.00
NADWS-240-3240	160	240	320	960	3240	13.5	17.8	\$1,425.50	\$1,341.50

Code	Optional Insulation	Canada	USA	See Page
WIB-4X2-1/4*	6 insulation boards per box. Total coverage 48 sq ft - board size: 2'x4'x1/4"	\$219.00	\$219.00	27

\* for mounting accessories, see page 27

Code	Thermostats	Max Load	Canada	USA	See Page
TEMPO	Programmable thermostat	15A	\$165.00	\$145.00	31
4iE-03BL	Warmup 4iE Thermostat, 120V/240V with sensor and Class A GFCI, black	15A	\$239.00	\$216.00	
4iE-03WH	Warmup 4iE Thermostat, 120V/240V with sensor and Class A GFCI, white	15A	\$239.00	\$216.00	
4iE-04BL	Warmup WiFi 4iE Thermostat, with sensor and Class A GFCI, black	15A	\$299.00	\$279.00	
4iE-04WH	Warmup WiFi 4iE Thermostat, with sensor and Class A GFCI, white	15A	\$299.00	\$279.00	

Code	Accessories	Canada	USA
M-DGMTR	The Alligator Tester - Digital Multimeter	\$23.00	\$20.00
REPAIR-INDOORS	Repair kit for 120/240V systems: REPAIR-ENDCAP, REPAIR-JOINT	\$12.00	\$10.00
DCM-SP-10K	Additional Floor Sensor for the 4iE®.	\$23.00	\$20.50
RELAY-25	General purpose 25A/240V relay used to expand the switching capability of the 4iE thermostat series. Mounts in single gang box.	\$96.00	\$80.00
PLG-E-12	Plastic fixing strips for NADWS Cable System spacing. Strips are 12" long with spacing available on 1" increments. Approximately 5/16" thick. Sold in box of 50 strips.	\$49.00	\$39.00

# NADWM Self-adhesive Heating Mats

Use under tile, stone & LVT.

The Warmup mat is designed for use within the adhesive layer under tiles or within a leveling compound under other floor finishes.

The fixed spacing and self-adhesive mat makes installation of regularly shaped rooms quick and easy, whilst ensuring precision is maintained.

The Mat System is ideal for installations within regularly shaped areas, where 20" wide mats can be quickly rolled out across the floor in parallel runs, cut and turned.

For floors using a vinyl, carpet, timber or other UFH compatible floor finishes including tiles,

the system can be covered with a leveling compound to provide a flat and level floor surface.

Alternatively, the Foil Heater System (p.20) offers a completely dry construction that does not require a leveling compound.

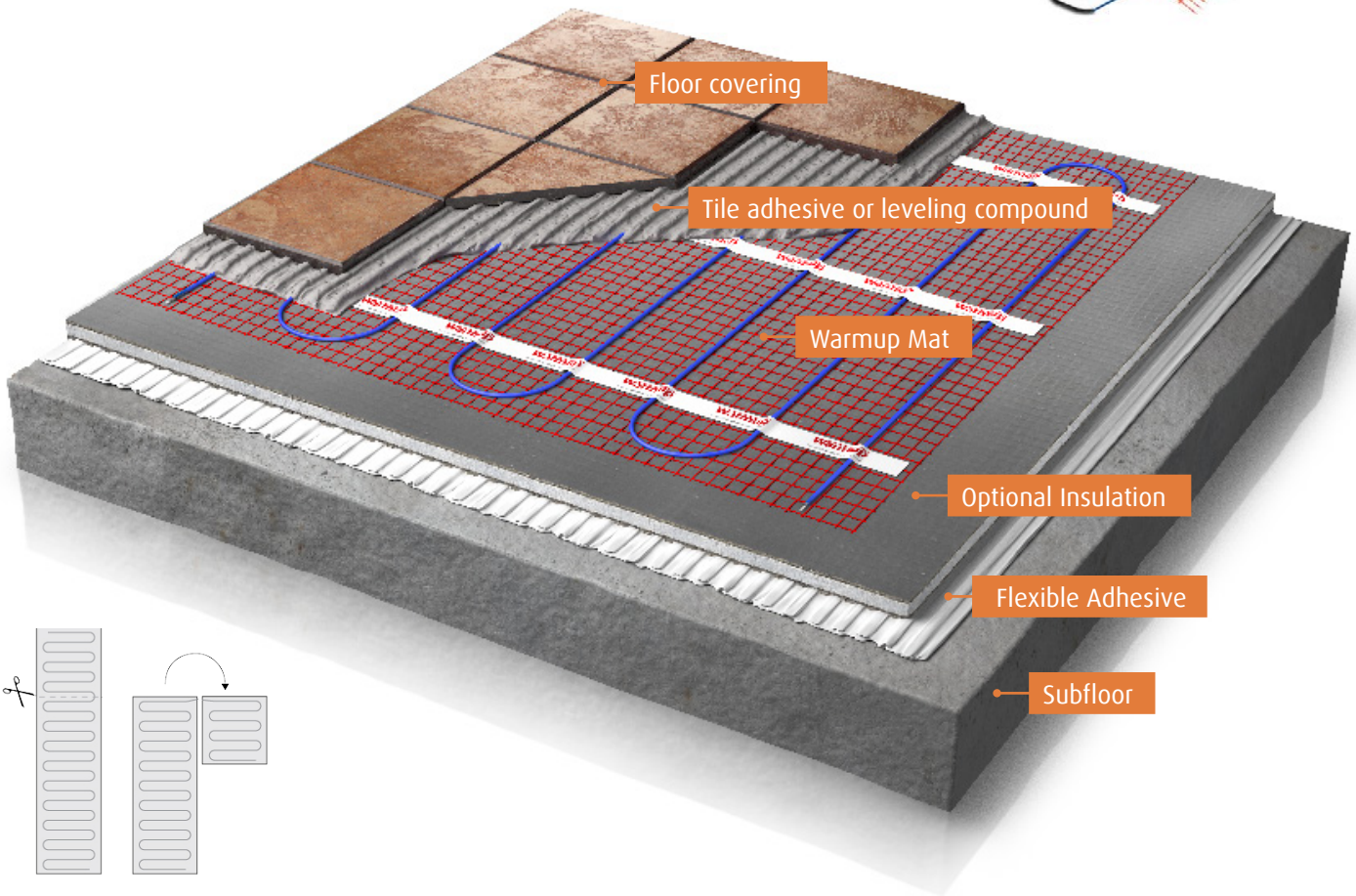





Area (sqft)	Code	Mat Length (ft) (20" wide)	Wattage	Amps	Resistance (Ω)	Canada	USA
10	NADWM-120-140	6'	140	1.2	102.8	\$242.50	\$211.00
15	NADWM-120-210	9'	210	1.8	68.5	\$307.00	\$267.00
20	NADWM-120-280	12'	280	2.3	51.4	\$345.00	\$300.00
25	NADWM-120-350	15'	350	2.9	41.2	\$384.00	\$334.00
30	NADWM-120-420	18'	420	3.5	34.3	\$423.00	\$368.00
40	NADWM-120-560	24'	560	4.7	25.7	\$525.50	\$457.50
50	NADWM-120-700	30'	700	5.8	20.6	\$629.00	\$547.00
60	NADWM-120-840	37'	840	7.0	17.1	\$731.50	\$636.00
75	NADWM-120-1050	46'	1050	8.8	13.7	\$885.50	\$770.50
90	NADWM-120-1260	55'	1260	10.5	11.4	\$1,027.00	\$893.00
110	NADWM-120-1540	67'	1540	12.8	9.4	\$1,195.00	\$1,061.50
120	NADWM-120-1620	73'	1620	13.5	8.9	\$1,284.50	\$1,117.50
25	NADWM-240-350	15'	350	1.5	164.6	\$384.00	\$334.00
40	NADWM-240-560	24'	560	2.3	102.9	\$525.50	\$457.50
50	NADWM-240-700	30'	700	2.9	82.3	\$629.00	\$547.00
75	NADWM-240-1050	46'	1050	4.4	54.9	\$885.50	\$781.50
90	NADWM-240-1260	55'	1260	5.3	45.7	\$1,027.00	\$893.00
110	NADWM-240-1540	67'	1540	6.4	37.4	\$1,220.00	\$1,039.50
150	NADWM-240-2100	91'	2100	8.8	27.4	\$1,542.00	\$1,341.50
180	NADWM-240-2520	110'	2520	10.5	22.9	\$1,799.50	\$1,565.00
220	NADWM-240-3080	134'	3080	12.8	18.7	\$2,057.50	\$1,789.00
240	NADWM-240-3240	146'	3240	13.5	17.8	\$2,186.00	\$1,901.00

Code	Optional Insulation	Canada	USA	See Page
WIB-4X2-1/4*	6 insulation boards per box. Total coverage 48 sq ft - board size: 2'x4'x1/4"	\$219.00	\$219.00	27

\* for mounting accessories, see page 27

Code	Thermostats	Max Load	Canada	USA	See Page
TEMPO	Programmable thermostat	15A	\$165.00	\$145.00	31
4iE-03BL	Warmup 4iE Thermostat, 120V/240V with sensor and Class A GFCI, black	15A	\$239.00	\$216.00	
4iE-03WH	Warmup 4iE Thermostat, 120V/240V with sensor and Class A GFCI, white	15A	\$239.00	\$216.00	
4iE-04BL	Warmup WiFi 4iE Thermostat, with sensor and Class A GFCI, black	15A	\$299.00	\$279.00	
4iE-04WH	Warmup WiFi 4iE Thermostat, with sensor and Class A GFCI, white	15A	\$299.00	\$279.00	

Code	Accessories	Canada	USA
M-DGMTR	The Alligator Tester - Digital Multimeter.	\$23.00	\$20.00
REPAIR-INDOORS	Repair kit for 120/240V systems.	\$12.00	\$10.00
DCM-SP-10K	Additional Floor Sensor for the 4iE®.	\$23.00	\$20.50
RELAY-25	General purpose 25A/240V relay used to expand the switching capability of the 4iE thermostat series. Mounts in single gang box.	\$96.00	\$80.00

# StickyMat™

## For fast installations in bathrooms

The Warmup StickyMat™ System is designed for use within the adhesive layer under tiles or within a leveling compound under other floor finishes.

The fixed spacing and self-adhesive mat makes installation of regularly shaped rooms quick and easy whilst ensuring precision is maintained.

The StickyMat™ range is ideal for small-to-medium sized bathrooms where our 3ft-wide mats can cover your open traffic area in one go.

The pressure sensitive adhesive securely binds the mats to the subfloor, keeping them flat and ensuring the application of tile adhesive allows a low-profile installation.

Offering the same high heat output as our traditional NADWM mats, the StickyMats can be combined on a single thermostat to cover an L-shape or a larger room.

They are suitable for installation under Tile & Stone and LVTs.

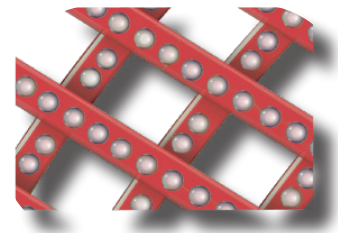

Close-up of the pressure-sensitive adhesive.

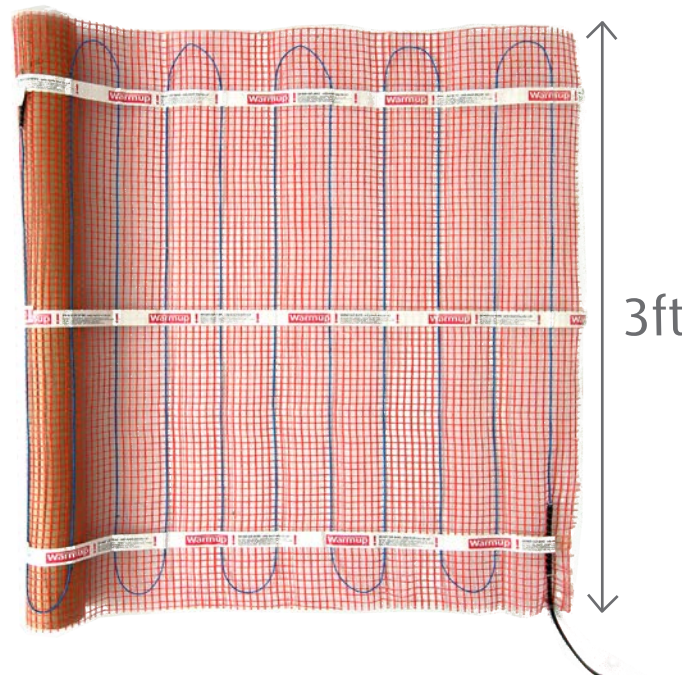



Mat Size (ft)	Code	Amps	Resistance ( $\Omega$ )	Canada	USA
3 x 3	NADWM-09-120	1.05	114.3	\$240.50	\$192.50
3 x 5	NADWM-15-120	1.75	68.5	\$295.50	\$257.00
3 x 6	NADWM-18-120	2.10	57.1	\$333.50	\$290.00
3 x 8	NADWM-24-120	2.80	42.9	\$402.50	\$322.00
3 x 10	NADWM-30-120	3.50	34.3	\$407.00	\$354.00

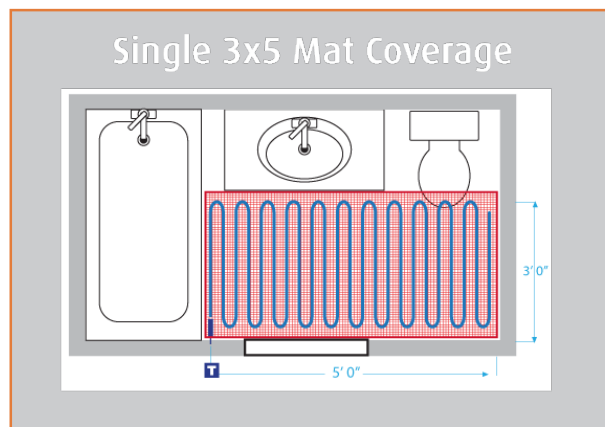
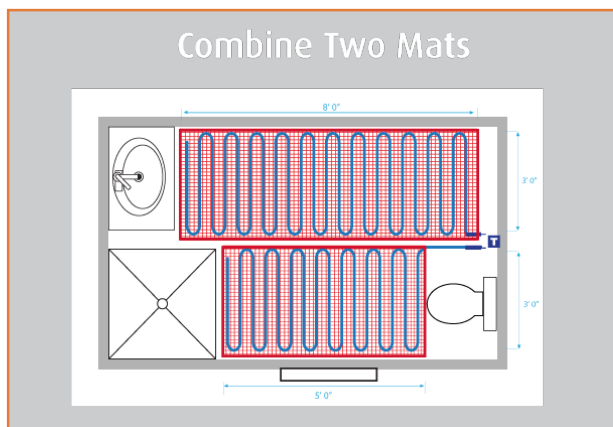

# FOIL System

For use under Carpet, Laminate and Floating Engineered Wood Floors.

The Warmup FOIL system is an electric mat for floating floors. It can be shaped to customize the installation under carpet and wood floors. The FOIL is installed between the pad and the floor covering, either carpet or wood planks.

All tested carpet pads are suitable under the FOIL heating mats. For laminate and wood installations, Warmup recommends the WIU insulation (p.27) to replace the typical polyurethane pad in order to provide better heat outputs and faster heat-up times.

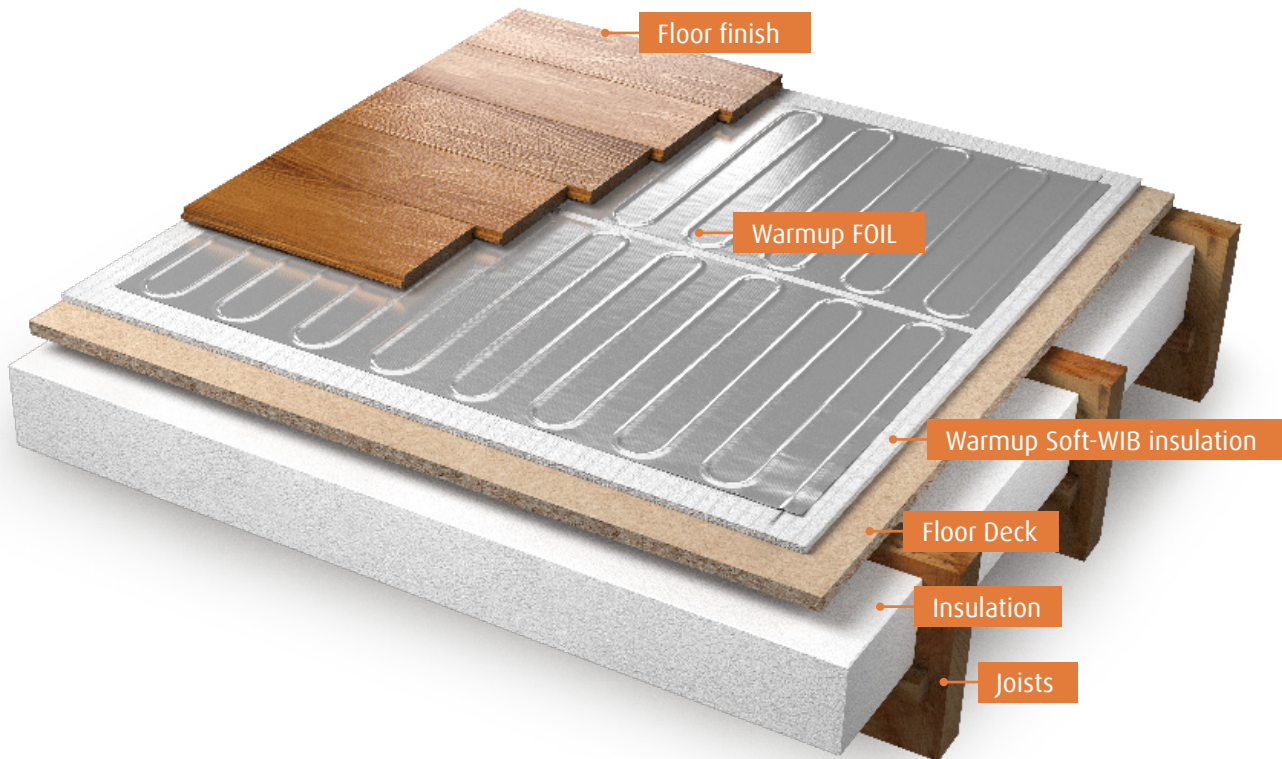



Area (sqft)	Code	Mat length (20" wide)	Wattage	Amps	Resistance ( $\Omega$ )	Canada	USA
20	FOIL-20-240	12'	240	1.0	240	\$226.00	\$215.50
25	FOIL-25-240	15'	300	1.3	192	\$283.50	\$270.00
40	FOIL-40-240	24'	480	2.0	120	\$431.50	\$431.50
50	FOIL-50-240	30'	600	2.5	96	\$539.50	\$539.50
60	FOIL-60-240	36'	720	3.0	80	\$646.50	\$646.50
70	FOIL-70-240	42'	840	3.5	69	\$754.50	\$754.50
95	FOIL-95-240	57'	1140	4.8	51	\$923.00	\$1,025.50
115	FOIL-115-240	69'	1380	5.8	42	\$1,146.00	\$1,146.00
130	FOIL-130-240	78'	1560	6.5	37	\$1,295.50	\$1,295.50
140	FOIL-140-240	84'	1680	7.0	34	\$1,395.50	\$1,395.50

Code	Optional Insulation	Canada	USA	See Page
SOFT-WIB-1/4	Warmup Insulation Underlay 270 sqft rolls	\$587.00	\$489.50	27

Code	Thermostats	Max Load	Canada	USA	See Page
TEMPO	Programmable thermostat	15A	\$165.00	\$145.00	31
4iE-03BL	Warmup 4iE Thermostat, 120V/240V with sensor and Class A GFCI, black	15A	\$239.00	\$216.00	
4iE-03WH	Warmup 4iE Thermostat, 120V/240V with sensor and Class A GFCI, white	15A	\$239.00	\$216.00	
4iE-04BL	Warmup WiFi 4iE Thermostat, with sensor and Class A GFCI, black	15A	\$299.00	\$279.00	
4iE-04WH	Warmup WiFi 4iE Thermostat, with sensor and Class A GFCI, white	15A	\$299.00	\$279.00	

Code	Accessories	Canada	USA
M-DGMTR	The Alligator Tester - Digital Multimeter	\$23.00	\$20.00
RELAY-25	General purpose 25A/240V relay used to expand the switching capability of the 4iE thermostat. Mounts in single gang box.	\$96.00	\$80.00
DCM-SP-10K	Additional Floor Sensor for the 4iE®.	\$23.00	\$20.50
TAPE-AL	Aluminum Foil Tape for grounding. Sold in 90ft roll.	\$24.50	\$20.50



# Loose Cable System for nailed-down Wood Floors

Use under nailed hardwood floors.

The Warmup loose cable for hardwood has been tested by many wood suppliers and is the ideal solution for radiant heating under solid wood floors. Installed at 3" to 4" spacing between sleepers about 10" to 16" on center, it allows for a nailing surface to protect the cable from damage. Filling the gaps between sleepers with thinset or drypack creates the

heat mass necessary to provide gradual and safe heating throughout the hardwood floors.

Electric floor heating systems do not affect moisture and will not impact your wood, unlike hydronic systems. It does not leak or freeze and is a tried and true solution in kitchens, basements, dining rooms and more.



Read more about the 4iE® Smart Thermostat, pre-programmed for wood floors and locked at 81°F.

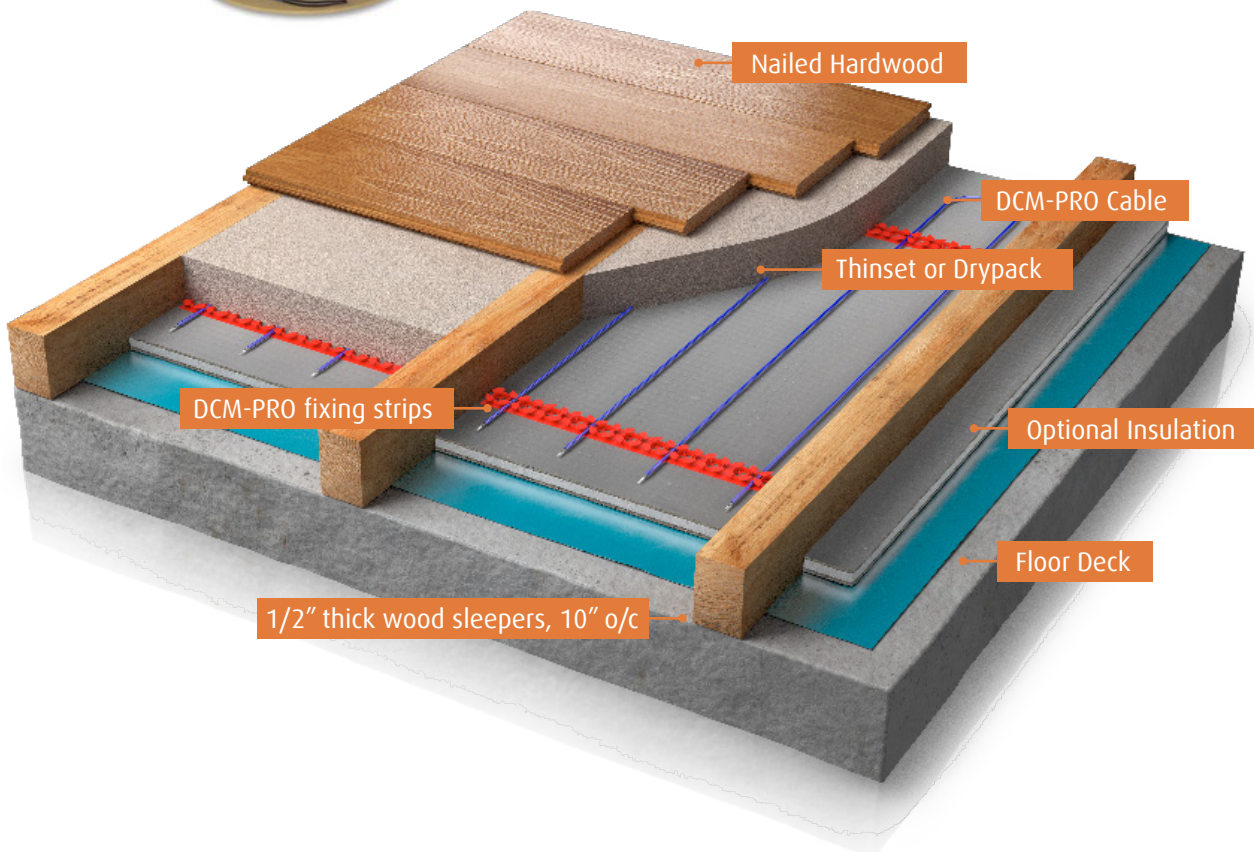



Code	Length (ft)	Resistance (Ω)	Amps	Membrane Spacing			Canada	USA
				2 pegs	3 pegs	4 pegs		
Cable spaced at gives sq ft coverage of								
NADCM-C-120-65	16.7	221.5	0.5	3	5	7	\$180.00	\$157.00
NADCM-C-120-130	33.1	110.8	1.1	7	10	13	\$209.00	\$181.00
NADCM-C-120-195	49.9	73.8	1.6	10	15	20	\$235.00	\$204.00
NADCM-C-120-260	66.3	55.4	2.2	13	20	27	\$266.00	\$231.00
NADCM-C-120-325	83.0	44.3	2.7	17	25	33	\$293.00	\$254.00
NADCM-C-120-390	99.4	36.9	3.3	20	30	40	\$303.00	\$263.00
NADCM-C-120-525	132.9	27.4	4.4	27	40	53	\$356.00	\$309.00
NADCM-C-120-655	166.0	22.0	5.5	33	50	67	\$409.00	\$355.00
NADCM-C-120-785	199.1	18.3	6.5	40	60	80	\$459.00	\$399.00
NADCM-C-120-920	232.3	15.6	7.7	47	70	93	\$511.00	\$444.00
NADCM-C-120-1050	265.4	13.7	8.8	53	80	107	\$565.00	\$491.00
NADCM-C-120-1180	298.6	12.2	9.8	60	90	120	\$619.00	\$538.00
NADCM-C-120-1315	331.7	11.0	11	67	100	133	\$670.00	\$582.00
NADCM-C-120-1445	364.8	10.0	12	73	110	147	\$723.00	\$628.00
NADCM-C-120-1575	398.0	9.1	13.1	80	120	160	\$776.00	\$674.00
NADCM-C-240-325	83.0	177.2	1.4	17	25	33	\$293.00	\$254.00
NADCM-C-240-390	99.4	147.7	1.6	20	30	40	\$303.00	\$263.00
NADCM-C-240-525	132.9	109.7	2.2	27	40	53	\$356.00	\$309.00
NADCM-C-240-655	166.0	87.9	2.8	33	50	67	\$409.00	\$355.00
NADCM-C-240-785	199.1	73.4	3.3	40	60	80	\$459.00	\$399.00
NADCM-C-240-920	232.3	62.6	3.9	47	70	93	\$511.00	\$444.00
NADCM-C-240-1050	265.4	54.9	4.5	53	80	107	\$565.00	\$491.00
NADCM-C-240-1180	298.6	48.8	5	60	90	120	\$619.00	\$538.00
NADCM-C-240-1310	331.7	44	5.6	67	100	133	\$670.00	\$582.00
NADCM-C-240-1640	414.7	35.1	7	83	125	167	\$800.00	\$695.00
NADCM-C-240-1970	497.7	29.2	8.4	100	150	200	\$915.00	\$871.00
NADCM-C-240-2300	580.7	25.0	9.8	117	175	233	\$1,006.00	\$958.00
NADCM-C-240-2630	663.4	21.9	11.2	133	200	266	\$1,044.00	\$994.00
NADCM-C-240-2955	746.4	19.5	12.6	150	225	300	\$1,118.00	\$1,064.00
NADCM-C-240-3240	829.4	17.8	13.5	167	250	333	\$1,229.00	\$1,170.00

Code	Thermostats	Max Load	Canada	USA	See Page
TEMPO	Programmable thermostat	15A	\$165.00	\$145.00	31
4iE-03BL	Warmup 4iE Thermostat, 120V/240V with sensor and Class A GFCI, black	15A	\$239.00	\$216.00	
4iE-03WH	Warmup 4iE Thermostat, 120V/240V with sensor and Class A GFCI, white	15A	\$239.00	\$216.00	
4iE-04BL	Warmup WiFi 4iE Thermostat, with sensor and Class A GFCI, black	15A	\$299.00	\$279.00	
4iE-04WH	Warmup WiFi 4iE Thermostat, with sensor and Class A GFCI, white	15A	\$299.00	\$279.00	

Code	Accessories	Canada	USA
M-DGMTR	The Alligator Tester - Digital Multimeter	\$23.00	\$20.00
REPAIR-INDOORS	Repair kit for 120/240V systems: REPAIR-ENDCAP, REPAIR-JOINT	\$12.00	\$10.00
DCM-SP-10K	Additional Floor Sensor for the 4iE®.	\$23.00	\$20.50
RELAY-25	General purpose 25A/240V relay used to expand the switching capability of the 4iE thermostat series. Mounts in single gang box.	\$96.00	\$80.00
PLG-DCM-12	Plastic fixing strips - Strips are 12" long with spacing available on 1" increments. Approximately 3/16" thick. Box of 40.	\$53.00	\$44.00

# WODH In-slab cable

## Cable System for Slab Pours up to 6".

The Warmup In-slab Cable System is designed for use within a slab floor construction. The cable spacing can be tailored to the heat requirements of the space and the thickness of the slab.

Warmup in-slab cables provide 20W per sqft or up to 70 BTUs

per hour and easily replace water-based applications. With an electric system there is no boiler, no pump, no manifolds and no maintenance.

It is the ideal solution for builders and remodelers in basements and room additions.

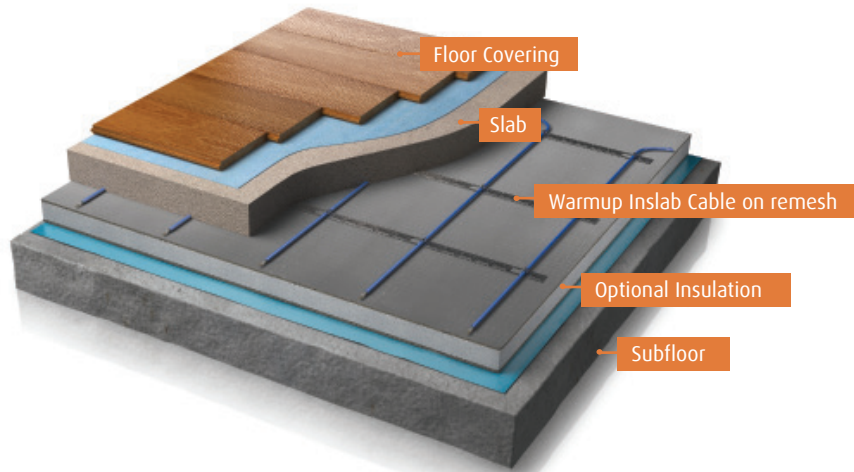

Cable length	Code	Cable spaced at 3" 4" 5" gives sq ft coverage of			Wattage	Amps	Resistance (Ω)	Canada	USA
93	WODH-D-240V-18W/500	24	30	39	500	2.1	114.30	\$319.00	\$266.50
176	WODH-D-240V-18W/950	44	59	74	950	4.0	60.00	\$487.00	\$406.50
250	WODH-D-240V-18W/1300	62	84	104	1300	5.4	44.40	\$561.50	\$468.50
315	WODH-D-240V-18W/1700	76	104	130	1700	7.1	33.80	\$710.50	\$592.50
437	WODH-D-240V-18W/2400	105	146	182	2400	10.0	24.00	\$953.00	\$794.00
625	WODH-D-240V-18W/3400	155	210	260	3400	14.2	16.90	\$1,141.00	\$951.50

Code	Thermostats	Max Load	Canada	USA	See Page
TEMPO	Programmable thermostat	15A	\$165.00	\$145.00	31
4iE-03BL	Warmup 4iE Thermostat, 120V/240V with sensor and Class A GFCI, black	15A	\$239.00	\$216.00	
4iE-03WH	Warmup 4iE Thermostat, 120V/240V with sensor and Class A GFCI, white	15A	\$239.00	\$216.00	
4iE-04BL	Warmup WiFi 4iE Thermostat, with sensor and Class A GFCI, black	15A	\$299.00	\$279.00	
4iE-04WH	Warmup WiFi 4iE Thermostat, with sensor and Class A GFCI, white	15A	\$299.00	\$279.00	

Code	Accessories	Canada	USA
M-DGMTR	The Alligator Tester Digital Multimeter	\$23.00	\$20.00
REPAIR-OUTDOORS	Repair kit for 120/240V systems: REPAIR-ENDCAP, REPAIR-JOINT	\$12.00	\$10.00
DCM-SP-10K	Additional Floor Sensor for the 4iE®	\$23.00	\$20.50
RELAY-25	General purpose 25A/240V relay used to expand the switching capability of the 4iE thermostat series. Mounts in single gang box.	\$96.00	\$80.00
USF-MB1	Metal fixing strips to fix the heating cable - 83 ft long	\$99.00	\$86.00



Insulation is the key to an  
efficient Primary Heat Source.

# Insulation Boards Under Tile

Warmup coated Insulation Boards are an important element when installing underfloor heating. They provide the foundation to lay the heating system.

The insulation improves the response time and heat retention within the room, reducing energy consumption and carbon emissions.

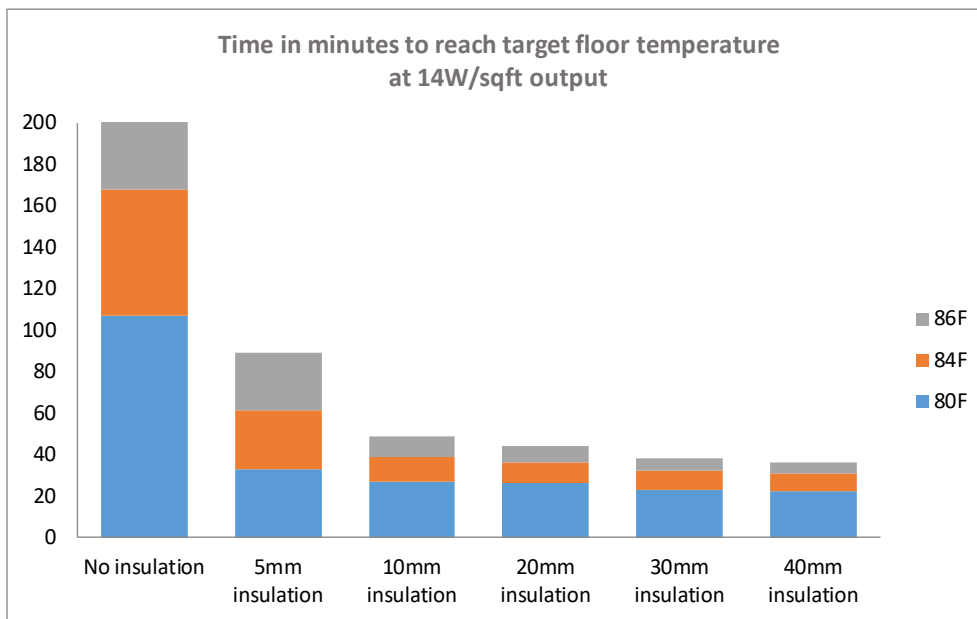

**78% FASTER**

**71% COST SAVINGS**



# Insulation Underlay For Wood Floors

Warmup Insulation Underlay is a thin polystyrene insulation barrier with effective acoustic properties to reduce contact noise.

It sits between the cold subfloor and Warmup FOIL Heating System, prevents heat loss and makes the underfloor heating system more efficient and effective. The Foil backing acts as an effective moisture barrier.

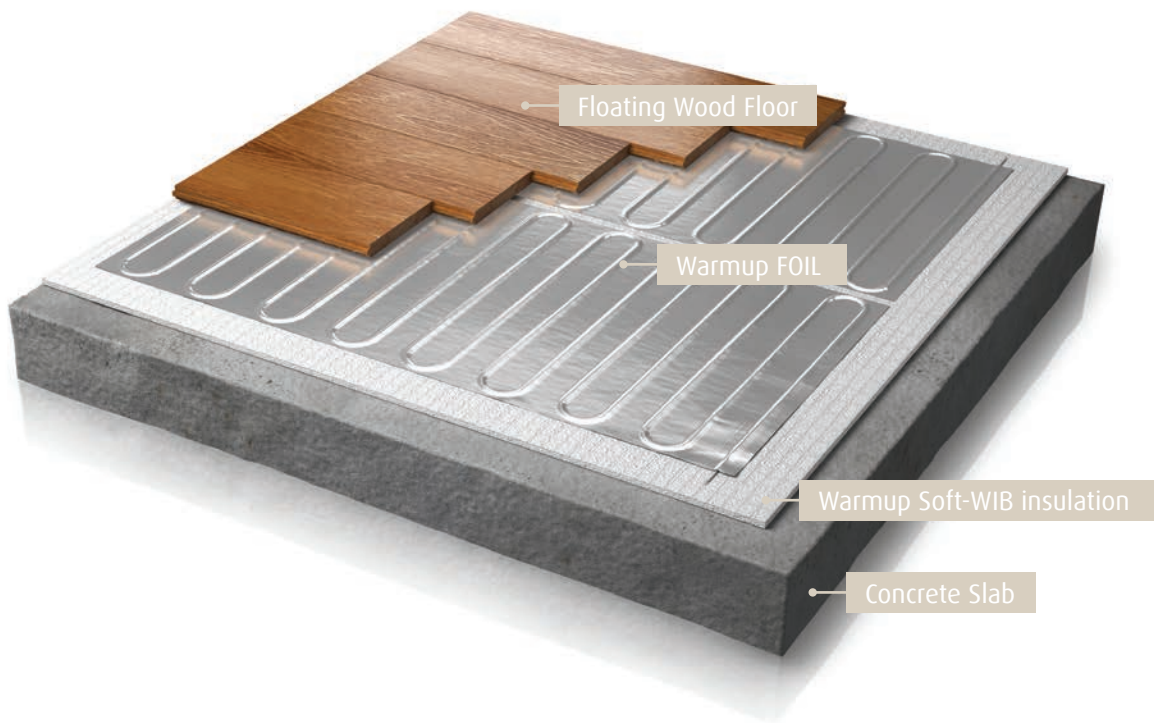

Code	Description	Canada	USA
WIB-4x2-1/4	Insulated Backer Board 1/4" Th, 4' x 2' (8 sqft). Minimum order of 6 boards.	\$219.00	\$219.00
WIB-S5/8	5/8" screws for WIB Installation. Sold in box of 100/ct.	N/A	\$30.00
WIB-W1/4	Washers w/o tabs for 1/4" WIB Installation. Sold in box of 100/ct.	N/A	\$30.00
WIB-SEALANT	Sealant for WIB seams and screws/washers. Required in wet areas only. One tube covers 6 boards.	N/A	\$19.00
SOFT-WIB-1/4	Warmup Insulation Underlay 270 sqft rolls	\$587.00	\$489.50

# Smart Devices



## 4iE® Smart WiFi Thermostat

For Electric Radiant Heating and Baseboard applications

Always at the right temperature, home or away

The 4iE® does not require programming. It works with your smartphone to ensure your home is always at the temperature you want, just as you arrive and uses more efficient temperatures when you are away.

If you want to use a conventional program or just want to make a quick change, the MyHeating app is simple and easy to use.

The most efficient settings for your home

The 4iE® learns how you use your heating and the unique way that your home responds to changes in temperature to calculate more efficient settings.

You will get tips with advice on comfortable temperatures that use less energy and the optimal times to turn the heating off early and still stay warm, **saving up to 25% on your heating usage.**

NEW!

## Tempo® Programmable Thermostat - Non GFCI



- **Simplicity:** Enables you to choose the time as easily as they would with a watch or clock and quickly set programs - heat on when you want it and off when you don't need it.
- **Compatibility** with all of Warmup's 120/240V range
- Clear screen displaying program details
- Easy control with dial and sliders



Tempo®  
An intuitive design for heating efficiency and simplicity.

## WUDG: Programmable Thermostat with GFCI



- Simple user interface
- Pre-programmed for quick set-up
- Multi voltage: 120-240V (incl. 208V)

# Thermostat Pricing

Code	Description	Max Load	Canada	USA
4iE-03BL	No WiFi 4iE® Thermostat, 120V/240V with sensor and Class A GFCI, black	15A	\$239.00	\$216.00
4iE-03WH	No WiFi 4iE® Thermostat, 120V/240V with sensor and Class A GFCI, white	15A	\$239.00	\$216.00
4iE-04BL	4iE® Smart WiFi Thermostat, with sensor and Class A GFCI, black	15A	\$299.00	\$279.00
4iE-04WH	4iE® Smart WiFi Thermostat, with sensor and Class A GFCI, white	15A	\$299.00	\$279.00
DCM-SP-10K	Additional Floor Sensor for the 4iE®	N/A	\$23.00	\$20.50
WUDG	Dual Voltage 120/240 Programmable Thermostat, w/ GFCI and Floor Sensor	15A	\$199.00	\$189.00
TEMPO	Programmable thermostat	15A	\$165.00	\$145.00

\*all thermostats include one floor sensor.

**DID YOU KNOW?**  
Our thermostats can be calibrated to suit the floor covering, to protect your wood floor covering and carpet.

## Thermostat installation

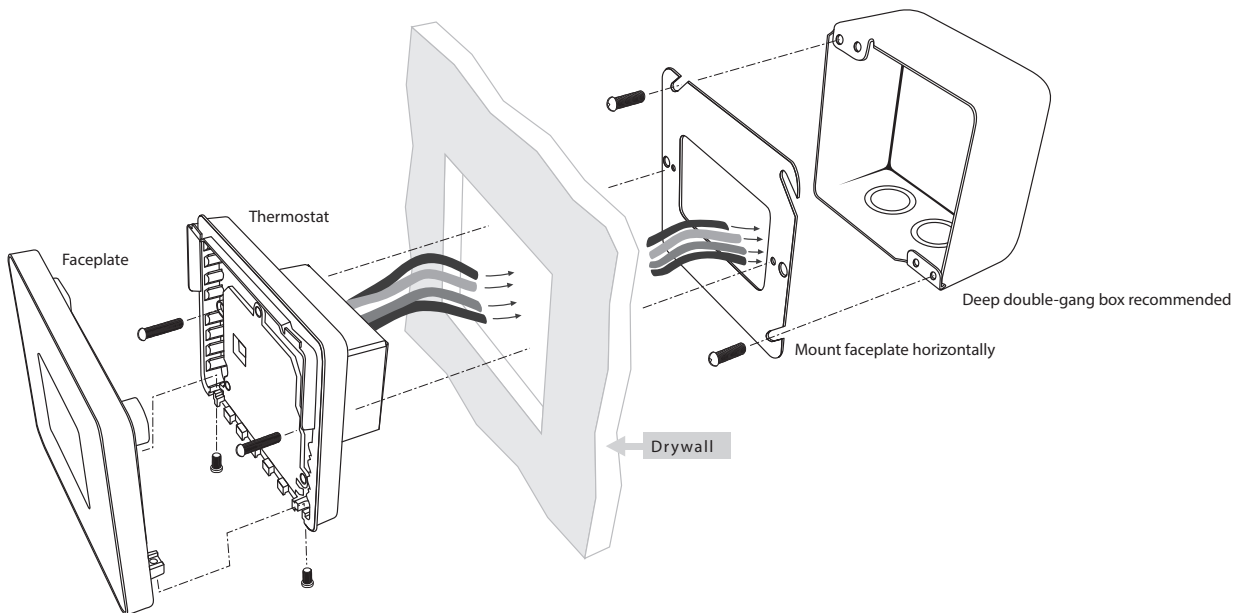

Close-up of the double-gang box with faceplate

# Bathroom Collection

Turn Your Bathroom into a Spa™





# Mirror defoggers

Little things that make all the difference.

- Available in 6 sizes
- Adhesive backed
- Easy to install
- Fog free mirror in seconds
- Fits most mirrors
- Low running cost
- Connects to existing lighting circuit



Product Code	Description	Shape	Wattage	Canada	USA
MD1624	Mirror Defogger Pads 16 x 24	Rectangular	80W	\$85.00	\$71.00
MD1826	Mirror Defogger Pads 18 x 26	Rectangular	80W	\$99.50	\$83.00
MD2432	Mirror Defogger Pads 24 x 32	Rectangular	80W	\$142.00	\$118.50
MD15	Mirror Defogger Pads 15"	Circular	40W	\$56.50	\$47.00
MD20	Mirror Defogger Pads 20"	Circular	40W	\$99.50	\$83.00
MD25	Mirror Defogger Pads 25"	Circular	40W	\$135.00	\$112.50



# Electric Towel Warmers

## Liberty Single bars

Available in Polished Stainless (round) and Brushed Stainless (square)

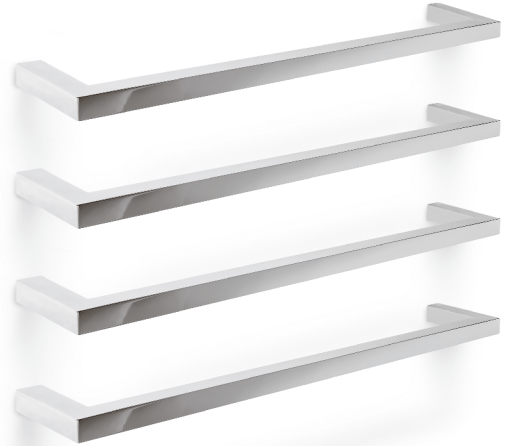

- 600mm wide / 24 inches
- All bars 110mm deep / 4 inches
- Round tubes: TW001
- Square tubes: TW002
- Select number of bars, minimum of 4.



1

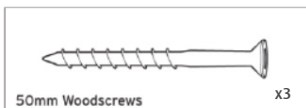

2

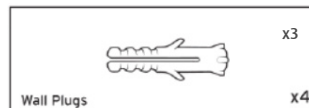

TW00X single bar fixing kit

### Liberty Single bars

Code	Description	Tube Shape	Bars	Width in mm	Depth in mm	Width centres in mm	Wattage	Canada	USA
TW001	Single bar	Round	1	600	110	575	9W	\$133.00	\$111.00
TW002	Single bar	Square	1	600	110	575	9W	\$147.50	\$123.00
TW00X	Single bar fixing kit	Order with each set of 4 bars.							

# Designer Square

Available in Polished Stainless Steel

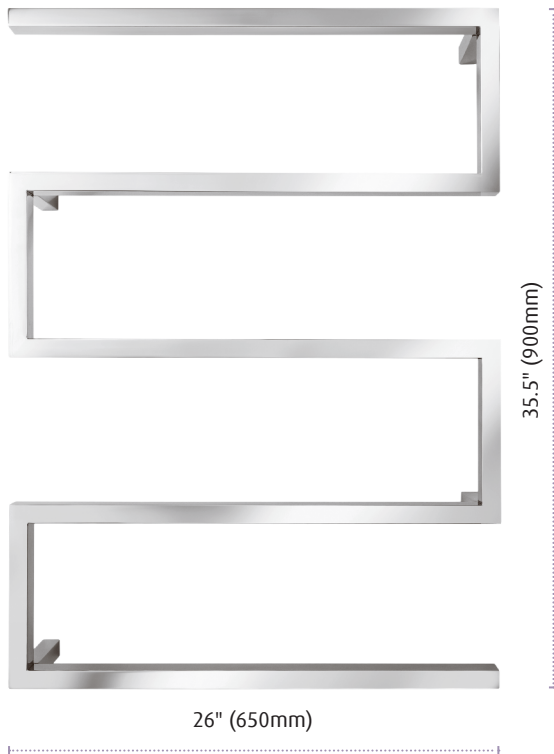

Model S - square tubes  
TW082

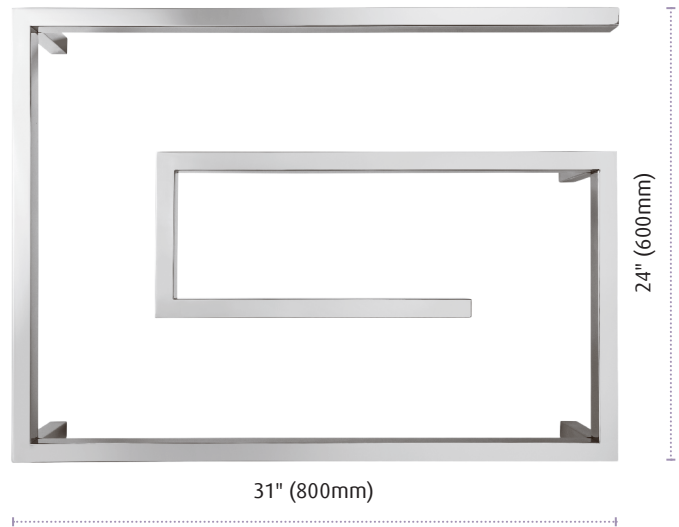

Model G - square tubes  
TW081

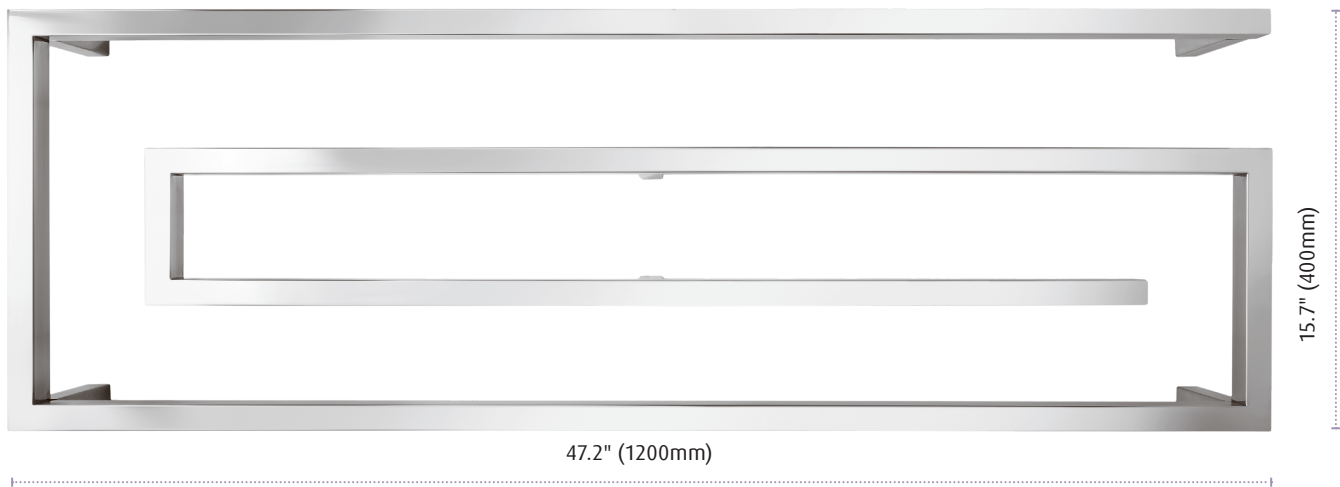

Paperclip / Square tubes  
TW080

## Designer Square

Code	Description	Tube Shape	Bars	Height in mm	Width in mm	Depth in mm	Width centres in mm	Vertical centres in mm	Wattage	Canada	USA
TW080	Paper clip	Square	4	600	800	115	765	575	60W	\$1,116.00	\$930.00
TW081	Model G	Square	4	400	1200	115	1165	255	80W	\$959.00	\$799.00
TW082	Model S	Square	5	900	650	115	-	-	60W	\$1,014.00	\$845.00

# Chelsea Round

Available in Polished Stainless Steel

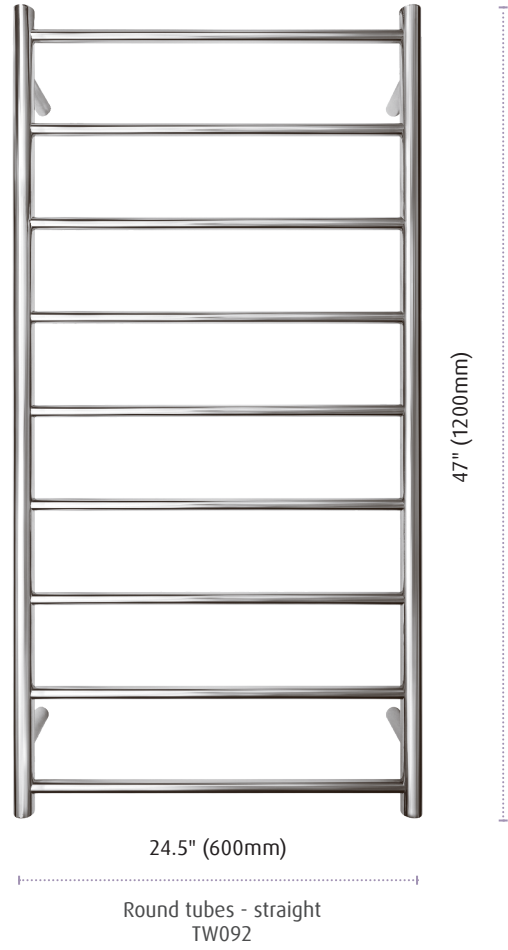
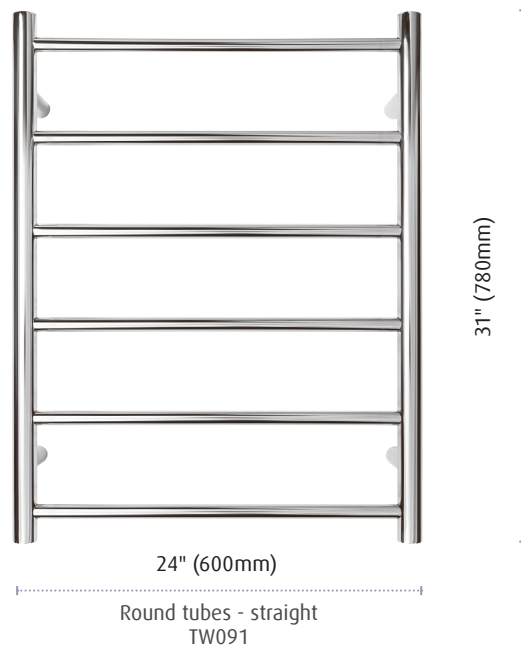
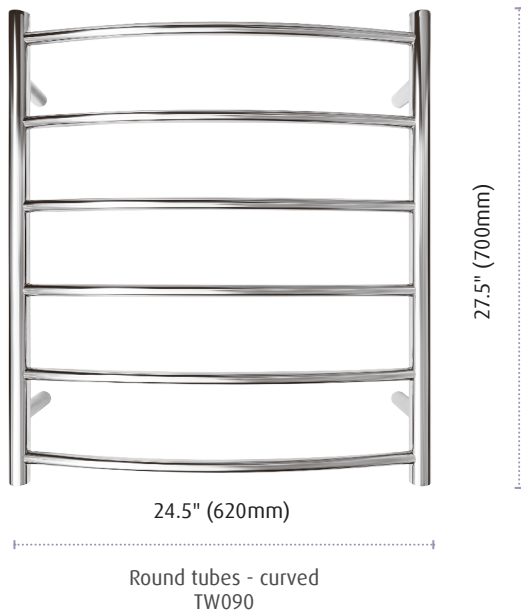

Chelsea Round											
Code	Description	Tube Shape	Bars	Height in mm	Width in mm	Depth in mm	Width centres in mm	Vertical centres in mm	Wattage	Canada	USA
TW090	Curved	Round	6	700	620	150	590	500	60W	\$515.00	\$429.00
TW091	Straight	Round	6	780	600	120	570	1000	60W	\$429.50	\$358.00
TW092	Straight	Round	9	1200	600	120	570	550	90W	\$558.00	\$465.00

# Times Square

Available in Brushed Stainless Steel



Times Square										
Code	Tube shape	Bars	Height in mm	Width in mm	Depth in mm	Width Centres	Vertical Centres	Wattage	Canada	USA
TW107	Square	7	920	620	120	595	720	80W	\$539.00	\$449.00
TW110	Square	10	1340	620	120	595	1140	110W	\$695.00	\$579.00

# Outdoor Heating

Snow Melting

Roof and Gutter De-icing

Pipe Freeze Control



Heating Cables and Mats from Warmup are very simple and cost-effective solutions to melt the snow on steps, walkways and driveways.

Whether for convenience or protection against liability, Warmup can help clear snow and ice with a very simple combination of heating cables and controls. Warmup systems can be installed under concrete, pavers or asphalt.

# Snow Melting Mats

Warmup systems are ideal to provide snow-free access to the house and prevent injuries on stairs and walkways.

They are commonly used in concrete pours, asphalt driveways and paved walkways.

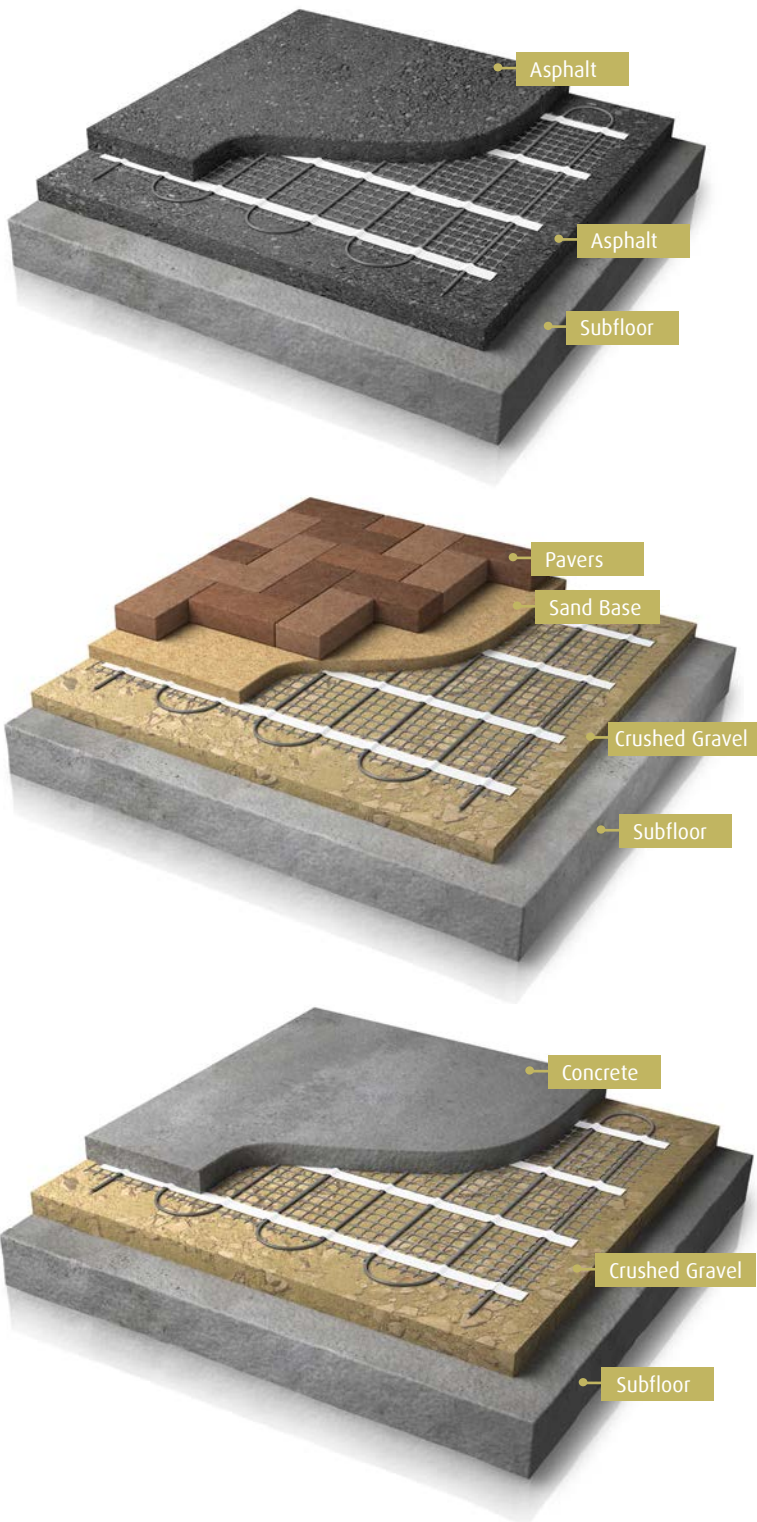

Mats are 2ft or 3ft wide and with a cable spacing providing 50w/sqft for optimum results under even the harshest conditions.

## FEATURES & BENEFITS

- Versatile installation in asphalt, concrete or under pavers
- Flexible cable: quick and easy to install in every configuration
- Dual conductor cable, one-point connection
- Available in a wide range of lengths to suit your requirements

## TECHNICAL DATA

- Operating voltage: 208, 240 and 480V
- Output rating: 50W / sq ft at 240V
- Energy efficient twin-conductor heating cable of 1/4"
- Rated to a maximum temperature of 464°F (240°C) under asphalt pours
- Cold tail length: 16'.4"
- 10-Year Warranty

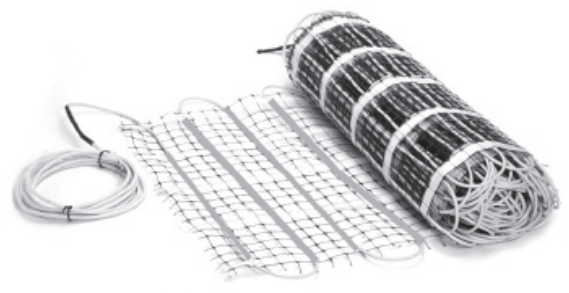





Voltage	Area (sqft)	Code	Mat Length (ft)	Wattage	Amps	Resistance (Ω)	Canada	USA
240V*	10	WSMM-D-240V-540W/500	5	500	2.1	115.20	\$253.00	\$211.00
	20	WSMM-D-240V-540W/1000	10	1000	4.2	57.60	\$348.00	\$290.00
	30	WSMM-D-240V-540W/1500	15	1500	6.3	38.40	\$467.50	\$389.50
	40	WSMM-D-240V-540W/2000	20	2000	8.3	28.80	\$534.50	\$445.50
	50	WSMM-D-240V-540W/2500	25	2500	10.4	23.00	\$569.50	\$513.50
	60	WSMM-D-240V-540W/3000	30	3000	12.5	19.20	\$697.00	\$581.00
	70	WSMM-D-240V-540W/3500	35	3500	14.6	16.46	\$800.00	\$666.50
	80	WSMM-D-240V-540W/4000	40	4000	16.7	14.40	\$903.00	\$752.50
	90	WSMM-D-240V-540W/4500	45	4500	18.8	12.80	\$980.50	\$817.00
	100	WSMM-D-240V-540W/5000	50	5000	20.8	11.50	\$1,113.50	\$928.00
	120	WSMM-D-240V-540W/6000	60	6000	25.0	9.60	\$1,183.00	\$1,073.50

\*all mats can be connected to 208V and 240V, single phase and 3 phase power.

Voltage	Area (sqft)	Code	Mat Length (ft)	Wattage	Amps	Resistance (Ω)	Canada	USA
240V*	30	WSMM-D-240V/3x10	10	1500	6.3	19.20	\$467.50	\$389.50
	60	WSMM-D-240V/3x20	20	3000	12.5	16.46	\$697.00	\$581.00
	75	WSMM-D-240V/3x25	25	3750	15.6	15.38	\$825.50	\$688.00
	90	WSMM-D-240V/3x30	30	4500	18.8	14.40	\$980.50	\$817.00
	120	WSMM-D-240V/3x40	40	6000	25.0	12.80	\$1,183.00	\$1,073.50

\*all mats can be connected to 208V and 240V, single phase and 3 phase power.

Voltage	Area (sqft)	Code	Mat Length (ft)	Wattage	Amps	Resistance (Ω)	Canada	USA
480V	30	WSMM-D-480V-540W/1500	15	1500	3.12	153.84	\$467.50	\$389.50
	40	WSMM-D-480V-540W/2000	20	2000	4.16	115.38	\$534.50	\$445.50
	60	WSMM-D-480V-540W/3000	30	3000	6.25	76.8	\$697.00	\$581.00
	80	WSMM-D-480V-540W/4000	40	4000	8.33	57.62	\$903.00	\$752.50
	120	WSMM-D-480V-540W/6000	60	6000	12.50	38.40	\$1,183.00	\$1,073.50

Code	Accessories	Canada	USA
NAMEPLATE-4x6	Branded Name Plate for use with Warmup Snow Melt Heater installations (NEC426-13)	\$45.50	\$38.00
M-DGMTR	The Alligator Tester - Digital Multimeter	\$23.00	\$20.00
REPAIR-OUTDOORS	Repair kit for 120/240V systems	\$12.00	\$10.00

For controls, see page 50.

# Snow Melting Cables

For custom layouts and spacing under concrete, pavers and asphalt pours.

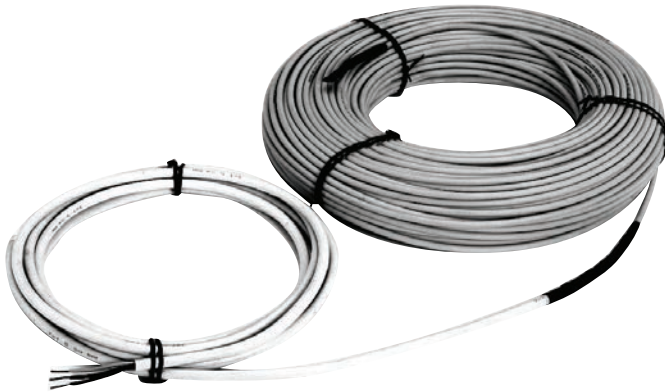

Snow Melting Cables are the loose equivalent of the Mats. The cables are reinforced with advanced fluoropolymer coatings to form a cable jacket that can withstand traffic and setting material.

Warmup's Cables are completely grounded and safe for installation under asphalt, pavers and concrete.

Choose the loose format for stairs and off-shaped areas, and combine with Mats wherever necessary.

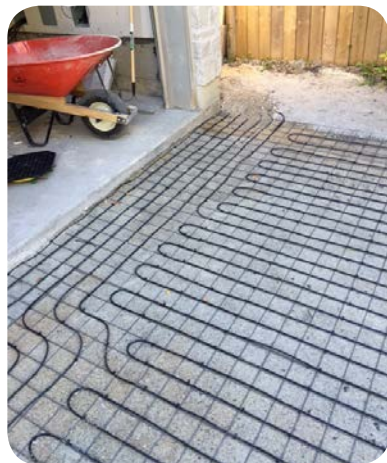

## FEATURES & BENEFITS

- Versatile installation in asphalt, concrete or under pavers
- Flexible cable: quick and easy to install in every configuration
- Dual conductor cable, one-point connection
- Available in a wide range of lengths to suit your requirements

## TECHNICAL DATA

- Operating voltage: 208, 240 and 480V
- Output rating: 12W / linear foot at 240V
- Energy efficient twin-conductor heating cable of 1/4"
- Rated to a maximum temperature of 464°F (240°C) for asphalt pours
- Cold tail length: 16'.4"
- 10-Year Warranty





Voltage	Length (ft)	Code	Cable spaced at			Wattage	Amps	Resistance (Ω)	Canada	USA
			3"	4"	5"					
240V**	84	WSM-D-240V-40W/1000	20	27	34	1000	4.2	57.1	\$265.00	\$221.50
	168	WSM-D-240V-40W/2000	43	57	72	2000	8.3	28.9	\$441.50	\$368.00
	209	WSM-D-240V-40W/2500	51	67	84	2500	10.4	23.1	\$509.00	\$424.50
	251	WSM-D-240V-40W/3000	62	84	104	3000	12.5	19.2	\$534.00	\$445.50
	330	WSM-D-240V-40W/4000	85	110	135	4000	16.7	14.2	\$683.00	\$569.50
	420	WSM-D-240V-40W/5000	100	140	170	5000	20.8	11.5	\$841.00	\$701.50
	500	WSM-D-240V-40W/6000	122	181	200	6000	25.0	9.6	\$979.00	\$816.00

\*all cables can be connected to 208V and 240V, single phase and 3 phase power.

Voltage	Length (ft)	Code	Wattage	Amps	Resistance (Ω)	Canada	USA
480V	84	WSM-D-480V-40W/1000	1000	2.08	230.77	\$265.00	\$221.50
	209	WSM-D-480V-40W/2500	2500	5.20	92.30	\$509.00	\$424.50
	342	WSM-D-480V-40W/4000	4000	8.33	57.62	\$683.00	\$569.50
	500	WSM-D-480V-40W/6000	6000	12.50	38.4	\$979.00	\$816.00

Code	Accessories	Canada	USA
NAMEPLATE-4x6	Branded Name Plate for use with Warmup Snow Melt Heater installations (NEC426-13)	\$45.50	\$38.00
REPAIR-OUTDOORS	Repair kit for 120/240V systems	\$12.00	\$10.00
M-DGMTR	The Alligator Tester - Digital Multimeter	\$23.00	\$20.00
USF-MB1	Metal fixing strips to fix the heating cable - 83 ft long	\$99.00	\$86.00

For controls, see page 50.

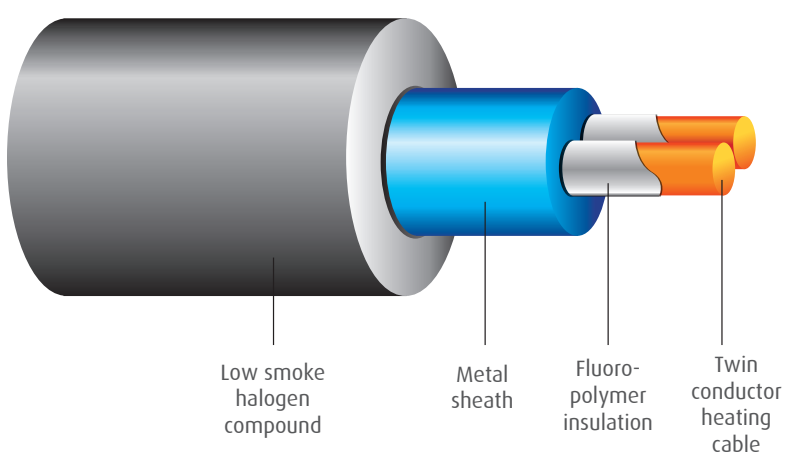

NAMEPLATE-4x6

# Roof and Gutter De-Icing Systems

## Self-regulating Cable.

Warmup's self-regulating roof deicing cables are heavy-duty cables that will ensure performance under the most challenging conditions. Ice dams can lead to water seeping and interior damage, falling ice and snow on sidewalks.

We have designed the right systems to protect your roofs, gutters and downspouts from damage or injury caused by falling ice.

Our self-regulating cable will vary its output based on ambient temperature. This reduces consumption costs by requiring just the amount of heat needed to get the job done.

With simple plug-in kits for residential use and large spools for engineered systems and commercial buildings, we look forward to being a part of your project.

### FEATURES & BENEFITS

- Self-regulating cable for cost-efficient operation
- Automatic controls to trigger heating only when needed
- Fits on all roof types with a full range of accessories
- Carries a 10-year warranty

### TECHNICAL DATA

- Commercial Grade, 16 AWG Buss Wire
- Standard Braid with Overjacket for Wet & Dry locations
- Circuit Lengths up to 540 Feet
- 5W/ft at 50°F output and 8W at 32°F
- Available in 120V and 208-277 Volts

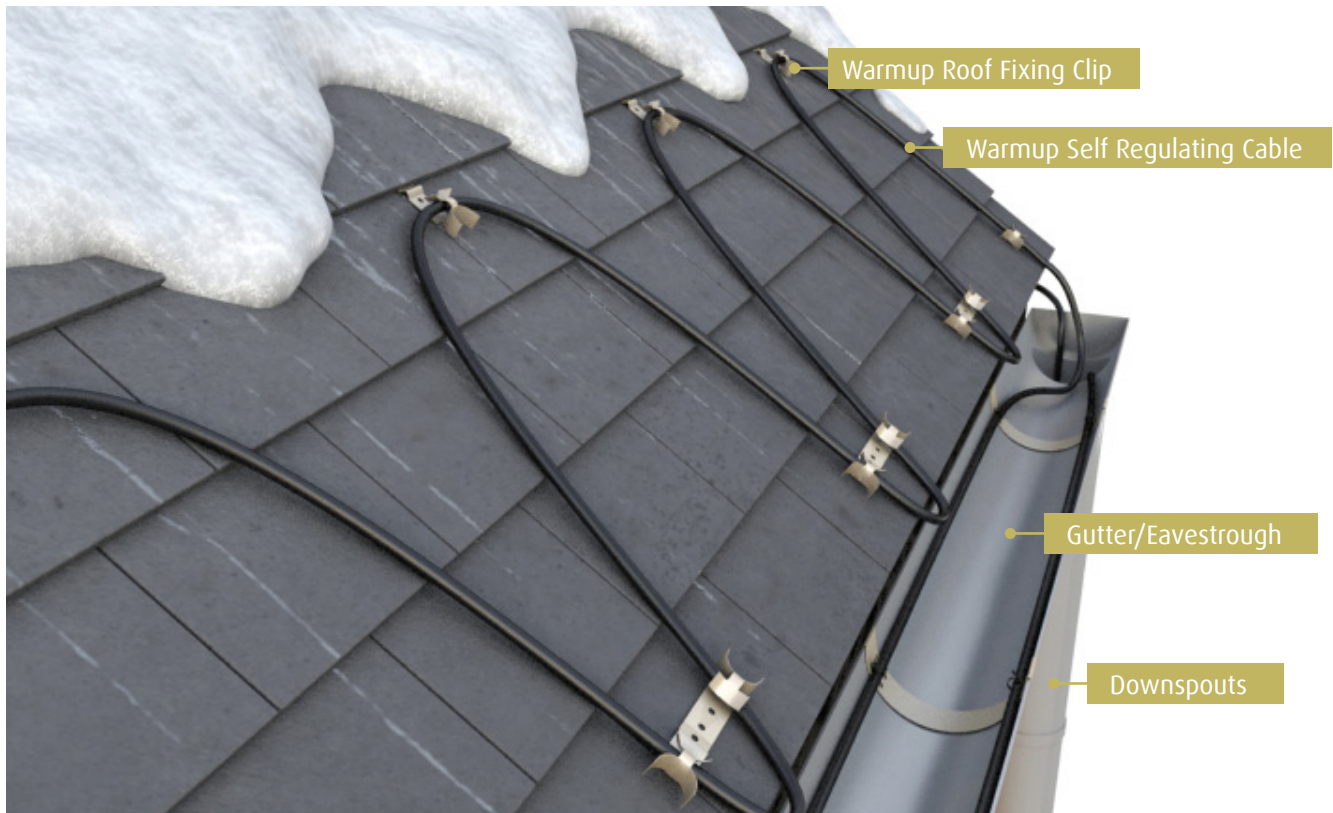



	Code	Description	Canada	USA
120V	NAMSR-5W-120-250	Self-Regulated 16GA Cable, 120V, 5W/linear foot. Sold in 250' length spools.	\$1,934.30	\$1,682.00
	NAMSR-8W-120-250	Self-Regulated 16GA Cable, 120V, 8W/linear foot. Sold in 250' length spools.	\$1,934.30	\$1,682.00
	NAMSR-5W-120-1000	Self-Regulated 16GA Cable, 120V, 5W/linear foot. Sold in 1000' length spools.	\$7,736.63	\$6,727.50
	NAMSR-8W-120-1000	Self-Regulated 16GA Cable, 120V, 8W/linear foot. Sold in 1000' length spools.	\$7,736.63	\$6,727.50
240V	NAMSR-5W-240-250	Self-Regulated 16GA Cable, 208-277V, 5W/linear foot. Sold in 250' length spools.	\$1,934.30	\$1,682.00
	NAMSR-8W-240-250	Self-Regulated 16GA Cable, 208-277V, 8W/linear foot. Sold in 250' length spools.	\$1,934.30	\$1,682.00
	NAMSR-5W-240-1000	Self-Regulated 16GA Cable, 208-277V, 5W/linear foot. Sold in 1000' length spools.	\$7,736.63	\$6,727.50
	NAMSR-8W-240-1000	Self-Regulated 16GA Cable, 208-277V, 8W/linear foot. Sold in 1000' length spools.	\$7,736.63	\$6,727.50
120V	NAMSRK-6FT	Self Regulating Kit with Plug, 6ft	\$89.00	\$74.50
	NAMSRK-12FT	Self Regulating Kit with Plug, 12ft	\$114.00	\$95.50
	NAMSRK-18FT	Self Regulating Kit with Plug, 18ft	\$140.50	\$117.50
	NAMSRK-24FT	Self Regulating Kit with Plug, 24ft	\$165.50	\$138.50
	NAMSRK-50FT	Self Regulating Kit with Plug, 50ft	\$295.00	\$246.50
	NAMSRK-75FT	Self Regulating Kit with Plug, 75ft	\$386.50	\$322.00
	NAMSRK-100FT	Self Regulating Kit with Plug, 100ft	\$476.50	\$397.00

Code	Description	Canada	USA
HANGER-KIT	Downspout Hanger for Self-Regulating Cable and Roof/Gutter heaters	\$24.00	\$20.50
NAM-POWER-KIT	Power Connection Kit for Self-Regulating Cable. Includes 2 warning labels	\$58.00	\$49.00
ROOF-CLIP	Metal single roof clips packaged and sold 50 per pkg. Secure to roof with screws or Everseal SB-190 adhesive or similar.	\$127.00	\$106.50
SB-190	Versatile adhesive to apply the Warmup ROOF-CLIP on a variety of roof structures. It is water and weather proof with a 2,000 lbs tensile strength.	\$37.00	\$31.00
NAM-SPLICE-KIT	Splice/Tee Kit for Self-Regulating Cable	\$48.00	\$40.00
NAM-END-KIT	End Seal Kit for Self-Regulating Cable	\$24.00	\$20.50
CRDS-15-GFI	6ft lead with GFCI 3-prong molded plug, NEMA 5-15,15 amp, 14/3	\$103.00	\$86.00
SPEEDFIT-BOX	Power connection junction box (6x6x3) with Pipe-Mounting Bracket for Self-Reg connections.	\$246.00	\$214.00
SPEEDFIT-SPLICE	In-line splicing box for fast and weathertight connections in the field	\$64.00	\$55.00
SPEEDFIT-TEE	3-Way T-splice box for fast and weathertight connections in the field	\$64.00	\$55.00

For controls, see page 52.

# Roof & Gutter De-icing Systems

## WRGH Constant Wattage Kits.

The Warmup WRGH is a constant wattage roof de-icing system supplied in pre-terminated plug-in kits.

It is offered in sizes from 30ft to 240ft, from 150W to 1,200W. It is supplied with roof clips and spacers.

WRGH kits are sold pre-assembled with a 3-prong plug in order to provide a simple, DIY solution to resolve ice dams and snow accumulation on roof lines.

For heavy-duty and commercial applications, please refer to the NAMS product range (p.45) from Warmup.

While spacing will impact the eventual output, the WRGH cables are designed for residential use.

An optional WRS-2 Controller can be purchased to reduce usage and electrical draw when temperatures are above 40°F. It is highly recommended, to increase product life and to reduce risk of fires or burn outs.



WRS-2 Controller

### TECHNICAL DATA

- Not suitable for Pipe Freeze Protection
- Do not overlap or terminate cable
- Turn system off after the snow season
- Must be connected to GFCI protected outlet or breaker.



Code	Length in Feet	Wattage	Voltage	W/lin. ft	Canada	USA
WRGH-120-150	30	150	120	5	\$105.50	\$88.00
WRGH-120-300	60	300	120	5	\$135.50	\$113.00
WRGH-120-400	80	400	120	5	\$173.00	\$144.00
WRGH-120-500	100	500	120	5	\$191.50	\$159.50
WRGH-120-600	120	600	120	5	\$242.50	\$202.00
WRGH-120-800	160	800	120	5	\$283.00	\$236.00
WRGH-120-1000	200	1000	120	5	\$341.50	\$284.50
WRGH-120-1200	240	1200	120	5	\$371.50	\$309.50

Code	Description	Canada	USA
WRS-2	Moisture & Temperature Controller for Warmup WRGH Roof & Gutter De-icing Kits	\$155.50	\$129.50

# SPEEDFIT Connections for Self-Regulating Cable

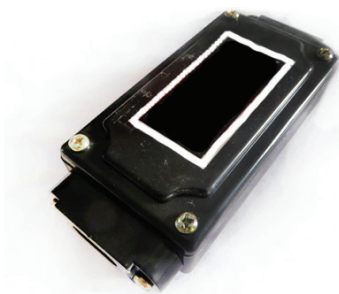

Speedfit Splice Kit (SPEEDFIT-SPLICE)

This Low-Profile Speedfit Splice Kit is suitable for use with Warmup NAMSRS self-regulating cable, to make splice and end seal connections. The kit contains materials for one splice kit. This kit does not provide a power connection: use WARMUP power connection kit for a complete installation (NAM-POWER-KIT).

**MSRP: \$55.00**



Speedfit Tee Kit (SPLICE-TEE)

This Low-Profile Speedfit Tee Kit is suitable for use with Warmup NAMSRS self-regulating cable. The Speedfit Tee is used to create a "T" connection with 3 self-regulating cables. This application is found on tracing runs for water lines as well as a replacement for downspout runs in roof and gutter applications.

**MSRP: \$55.00**

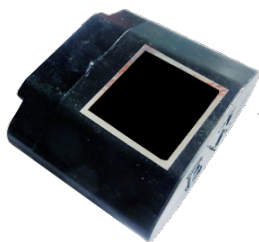

End Seal Kit (NAM-END-KIT)

The Warmup End Seal Kit is a solid termination kit for NAMSRS self-regulating cables. Used on both Roof & Gutter and for Pipe-Freeze Protection applications, the End Seal Kit provides the installer with a solid, mechanical cable termination. It saves time and materials over traditional heat-shrinking techniques.

**MSRP: \$20.50**

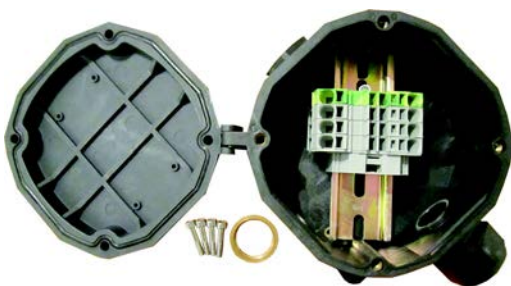

Speedfit Box (SPEEDFIT-BOX)

As standard, robust and corrosion resistant polyamide enclosures are supplied for use in safe (non-hazardous) or hazardous (Class1,Div.2) areas. When used in hazardous areas, the enclosures provide type EExe protection (increased safety) in "Electrical Apparatus for Potentially Explosive Atmospheres".

**MSRP: \$214.00**

These connection kits must be installed according to NAMSRS guidelines and minimum installation temperatures.

# Pipe Freeze Protection

Self-regulating cable for indoor and outdoor application.

Available in cut-to-length spools or plug-in kits, the Warmup Cable is applicable on metal, PVC and ceramic pipes, sprinkler systems and sewer drains.

causes its output of 5 or 8 W/lin ft to vary automatically with the outside conditions, thereby guaranteeing the safeguard of ducts and pipes.

The nature of the Self-regulating Cable

## TECHNICAL DATA

- Self-Regulating, Energy Efficient
- Output increases as temperature drops
- Commercial Grade, 16 AWG Buss Wire
- Approved for Wet and Dry locations
- Standard Braid with Overjacket
- Circuit lengths up to 540 feet
- 5 and 8 Watts per lin ft @ 50°F
- 120, 208-277 Volts available from stock

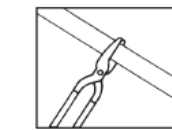

Cut to any length in field

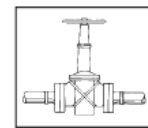

Can be single overlapped

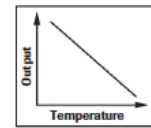

Self Regulating

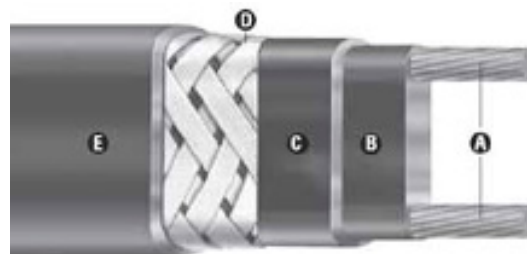

## CONSTRUCTION

- A. Buss Wires
- B. Matrix
- C. Jacket
- D. Tinned Copper Braid
- E. Overjacket







	Code	Description	Canada	USA
120V spools	NAMSR-5W-120-250	Self-Regulated 16GA Cable, 120V, 5W/linear foot. Sold in 250' length spools.	\$1,934.30	\$1,682.00
	NAMSR-8W-120-250	Self-Regulated 16GA Cable, 120V, 8W/linear foot. Sold in 250' length spools.	\$1,934.30	\$1,682.00
	NAMSR-5W-120-1000	Self-Regulated 16GA Cable, 120V, 5W/linear foot. Sold in 1000' length spools.	\$7,736.63	\$6,727.50
	NAMSR-8W-120-1000	Self-Regulated 16GA Cable, 120V, 8W/linear foot. Sold in 1000' length spools.	\$7,736.63	\$6,727.50
240V spools	NAMSR-5W-240-250	Self-Regulated 16GA Cable, 208-277V, 5W/linear foot. Sold in 250' length spools.	\$1,934.30	\$1,682.00
	NAMSR-8W-240-250	Self-Regulated 16GA Cable, 208-277V, 8W/linear foot. Sold in 250' length spools.	\$1,934.30	\$1,682.00
	NAMSR-5W-240-1000	Self-Regulated 16GA Cable, 208-277V, 5W/linear foot. Sold in 1000' length spools.	\$7,736.63	\$6,727.50
	NAMSR-8W-240-1000	Self-Regulated 16GA Cable, 208-277V, 8W/linear foot. Sold in 1000' length spools.	\$7,736.63	\$6,727.50
120V Kits	NAMSRK-6FT	Self Regulating Kit with Plug, 6ft	\$89.00	\$74.50
	NAMSRK-12FT	Self Regulating Kit with Plug, 12ft	\$114.00	\$95.50
	NAMSRK-18FT	Self Regulating Kit with Plug, 18ft	\$140.50	\$117.50
	NAMSRK-24FT	Self Regulating Kit with Plug, 24ft	\$165.50	\$138.50
	NAMSRK-50FT	Self Regulating Kit with Plug, 50ft	\$295.00	\$246.50
	NAMSRK-75FT	Self Regulating Kit with Plug, 75ft	\$386.50	\$322.00
	NAMSRK-100FT	Self Regulating Kit with Plug, 100ft	\$476.50	\$397.00

Code	Description	Canada	USA
TAPE-AL	Aluminum Foil Tape for Self-Regulating Cable. Sold in 90ft roll.	\$24.50	\$20.50
NAM-POWER-KIT	Power Connection Kit for Self-Regulated Cable. Includes 2 warning labels.	\$58.00	\$49.00
NAM-SPLICE-KIT	Splice/Tee Kit for Self-Regulating Cable.	\$48.00	\$40.00
NAM-END-KIT	End Seal Kit for Self-Regulating Cable.	\$24.00	\$20.50
SPEEDFIT-BOX	Power connection junction box (6x6x3) with Pipe-Mounting Bracket for Self-Reg connections.	\$246.00	\$214.00
SPEEDFIT-SPLICE	In-line splicing box for fast and weathertight connections in the field.	\$64.00	\$55.00
SPEEDFIT-TEE	3-Way T-splice box for fast and weathertight connections in the field.	\$64.00	\$55.00

For controls, see page 53.

# Residential Snow Melting Controls

Code	Description	Max amp.	Canada	USA
ASE-DS2	Snow/Ice Melt All-In-One Control Unit, 1 Zone control, ground and roof, 115/230VAC, 30 amps.	30A	\$773.00	\$644.00
ASE-DS5	Snow/Ice Melt All-In-One Control Unit, 2 Zone control, ground and roof, 115/230VAC, 2 x 30 amps.	2 x 30A	\$835.00	\$696.00
CDP-2	Indoor Control Panel for DS series. Fits any standard Single Gang electrical enclosure.	N/A	\$252.00	\$210.00
USETO3	Snow Melt controller 3x30A with GFEP. Compatible with ETOG	N/A	\$913.00	\$761.00



DS-2C



DS-5C

These controllers are for smaller projects up to 250 sqft. By combining controller and sensor all in one device, they are a simple addition to the Warmup heating system.



CDP-2

Code	Description	Max amp.	Canada	USA
WSM-63	Versatile panel to switch loads from Snow Melting and Roof De-icing applications. Also available for 3-phase wiring from 100-600V.	252A at 240V	\$2,019.00	\$1,615.20
USETO2-4550	Programmable controller for roof and pavement applications, 2 zone control, 115/230VAC, 3*15 amp contacts.	3x15A	\$768.00	\$640.00
USETOG-56	Snow/Ice Melt Pavement Sensor for use with USETO2-4550 Control	N/A	\$486.00	\$405.00





# Commercial Snow Melting Controls

Code	Description	Max Amperage	Canada	USA
COMMBOX-600	Plug-and-Play outdoor controller with 4 x 50A/3 pole contactors allowing for a total load of 600A with a minimum power supply of 60A. Comes in LED enclosure with GFEP protection, built-in Digital controller and ground temperature sensor.	600A	\$6,519.60	\$5,433.00
AIRsense	Outdoor moisture and temperature sensor, supplied with mounting bracket.	N/A	\$939.00	\$782.50
APS-3C	Snow Melting Controller with incl. slab sensor and built-in dry contacts for EMC and remote control. Rated 208-277V single phase.	N/A	N/A	\$2,496.50
CIT-1	The maintenance-free CIT sensors activate snow melting systems below 38°F and provide automatic triggering of APS series panels. Mast or roof mounting.	N/A	N/A	\$869.50
GIT-1	GIT-1 gutter sensor for APS-3C panel. Measures moisture & temperature. Active below 38°F.	N/A	N/A	\$1,247.00
GF-PRO	Automatic Controller with GFEP and GF Load.	30A	N/A	\$ \$1,746.50



COMMBOX-600

This control panel includes everything. With built-in relay contactors and GFEP protection, these panels can switch up to 4 times the supplied voltage. This means you can create up to 4 zones but power them one at a time, thereby reducing the amount of amperage needed to run the system.

Ideal for larger projects over 1,000 sqft.



GF-PRO

The GF-PRO can be mounted outdoors and switch up to 120 sqft of mats and cables. It is triggered by external roof or slab sensors for a more accurate reading of the weather conditions. Use with CIT-1, GIT-1 or SIT-6E sensors

# Roof and Gutter De-icing Controls

Code	Description	Max Amp.	Canada	USA
ASE-DS8	Automatic controller with remote moisture sensor and 30A relay.	30A	\$872.50	\$727.00
CDP-2	Indoor Control Panel for DS series. Fits any standard Single Gang electrical enclosure.	N/A	\$252.00	\$220.00
WRS-2	Roof and Gutter Heating Cable Controller (works with WRGH, see page 46).	15A	\$155.50	\$129.50



ASE-DS8



CDP-2



WRS-2

The DS-8C offers installation convenience, with the relay and sensor all mounted on one single enclosure. It is mounted outside and its sensor dropped inside the gutter for accurate readings. It can control up to 30 amps of roof cable, usually enough for a couple of faces of a typical suburban home. Optional CDP-2 remote control.





# Freeze Protection Controls

Code	Controls	Max Amp.	Canada	USA
TF115-001	Line voltage controller 120v - 277v, NEMA 4X enclosure with remote temperature sensor.	N/A	\$222.00	\$185.00
CRDS-15-GFI	6ft lead with GFCI 3-prong molded plug, NEMA 5-15, 15 amp, 14/3.	15A	\$103.00	\$86.00
SST-2	Electronic Thermostat with GFEP for Freeze Protection - 30A w/ GFEP.	30A	\$2,238.00	\$1,865.00



CRDS -15-GFI



SST-2



TF115-001

The TF115 will switch up to 22 amps or about 500ft of cable and will only activate based on temperature.

You set a temperature between 30F and 40F and the system will trigger, whether it snows or not. Not the most accurate, but the best value at under \$200.



NEW!

# Snow Melting and Roof De-icing Relay Timer Panel WSM-63

Warmup's very own WSM-63 panel is a versatile panel to switch loads from Snow Melting and Roof De-icing applications.

It can be used by itself with the integrated timer module or connected to a third-party sensor mounted outside.

## Features & Benefits

- Operate as Timer panel without sensor
- Connects to third-party sensors
- On/Off indicator on enclosure
- Timer trigger on enclosure door
- Suitable for 120-208-240-277-347-480 volts applications



## Technical Data

<b>Enclosure</b>	NEMA 1
<b>Relay</b>	2 x 63A/4-pole relay contactor 100-600V relay voltage
<b>Sensor</b>	120V coil for sensor connections
<b>Amps capacity</b>	Total capacity of 252 Amps at 240V/2-phase Total Capacity of 378 Amps at 277V/3-phase
<b>Approval</b>	UL-approved components

## Application

<b>Operate</b>	WSM/WSMM snow melting installations outdoors WODH in-slab applications indoors NAMSRS cables on pipes and roofs
----------------	---

Code	Description	Max amp.	Canada	USA
WSM-63	Versatile panel to switch loads from Snow Melting and Roof De-icing applications. Also available for 3-phase wiring from 100-600V.	252A at 240V	\$2,019.00	\$1,615.20

Add optional sensor activation with USASE-DS2 or USET02/USETOG combination. See page 50.

VISIT WARMUPEDIA.WARMUP.COM

SHOP OUR SELECTION OF SHOWROOM DISPLAYS, SAMPLES AND MORE!

Warmup

Floor Heating ▾ Thermostats ▾ Snow and Ice Melting ▾ Outdoor Controllers ▾ Bathroom Collection ▾ Shop 🛒 🔍

## Shop

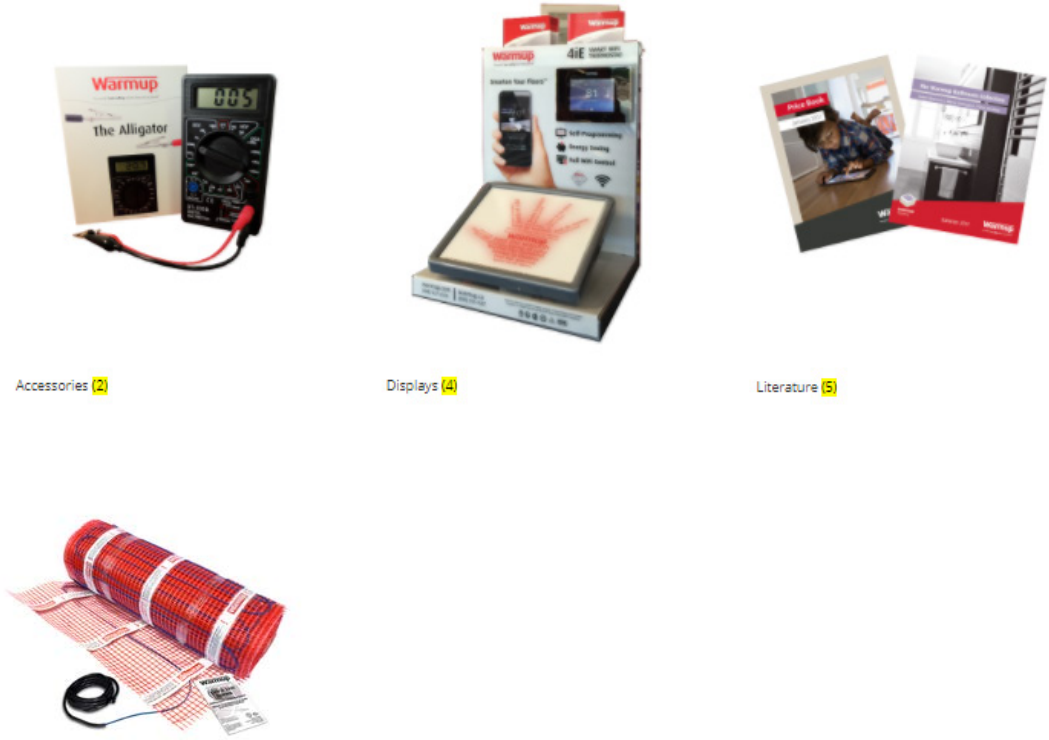

Accessories **(2)**

Displays **(4)**

Literature **(5)**

Product Samples **(4)**

The image shows a screenshot of the Warmup website's 'Shop' page. At the top, there is a navigation bar with the Warmup logo and several menu items: 'Floor Heating', 'Thermostats', 'Snow and Ice Melting', 'Outdoor Controllers', 'Bathroom Collection', and 'Shop'. Below the navigation bar, the word 'Shop' is displayed in a large font. The main content area features four product categories, each with a representative image and a count in parentheses: 'Accessories (2)' with an image of a multimeter and its packaging; 'Displays (4)' with an image of a digital display unit showing a handprint; 'Literature (5)' with an image of several brochures; and 'Product Samples (4)' with an image of a roll of red heating mat and a sample card.

# Warmup

The world's **best-selling** floor heating brand™



Warmup Inc.  
52 Federal Road, Unit 1F  
Danbury, CT 06810  
USA

T: (888) 927-6333  
F: (888) 927-4721

[www.warmup.com](http://www.warmup.com)  
[us@warmup.com](mailto:us@warmup.com)



Warmup Inc.  
C/O TH 1067  
PO BOX 4283 | Postal Station A  
Toronto ON M5W 5W6

T: (888) 592-7687  
F: (888) 927-4721

[www.warmup.ca](http://www.warmup.ca)  
[ca@warmup.com](mailto:ca@warmup.com)



Warmup Inc.  
Mexico

T: +52 (55) 8114 0145  
o +52 (55) 8114 0146

[www.warmup.com.mx](http://www.warmup.com.mx)  
[mexico@warmup.com](mailto:mexico@warmup.com)

More information on  
[\*\*warmupedia.warmup.com\*\*](http://warmupedia.warmup.com)

Warmupedia documents  
installation tips and  
troubleshooting guides for  
all Warmup products.