

WOODS BRUSHBULL™ ROTARY CUTTER

BB48

BB60

BB72

BB84

S/N 994127 & AFTER
Includes Service & Parts Information
for S/N 994126 & Prior

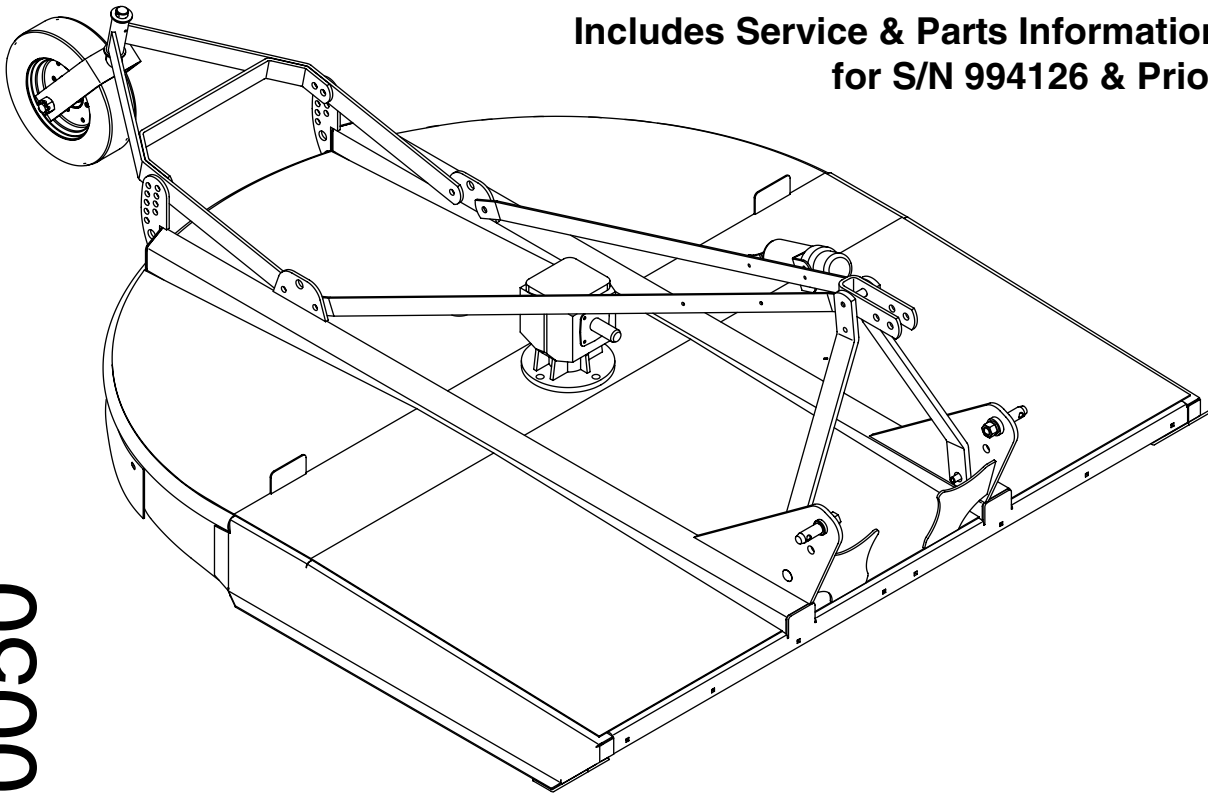

MAN0050

Rev. 10/27/2006

WOODS®
Tested. Proven. Unbeatable.

OPERATOR'S MANUAL

TO THE DEALER:

Assembly and proper installation of this product is the responsibility of the Woods® dealer. Read manual instructions and safety rules. Make sure all items on the Dealer's Pre-Delivery and Delivery Check Lists in the Operator's Manual are completed before releasing equipment to the owner.

The dealer must complete the Product Registration included with the Operator's Manual. The customer must sign the registration which certifies that all Dealer Check List items have been completed. The dealer is to return the prepaid postage portion to Woods, give one copy to the customer, and retain one copy. **Failure to complete and return this card does not diminish customer's warranty rights.**

TO THE OWNER:

Read this manual before operating your Woods equipment. The information presented will prepare you to do a better and safer job. Keep this manual handy for ready reference. Require all operators to read this manual carefully and become acquainted with all adjustment and operating procedures before attempting to operate. Replacement manuals can be obtained from your dealer. To locate your nearest dealer, check the Dealer Locator at www.WoodsEquipment.com, or in the United States and Canada call 1-800-319-6637.

The equipment you have purchased has been carefully engineered and manufactured to provide dependable and satisfactory use. Like all mechanical products, it will require cleaning and upkeep. Lubricate the unit as specified. Observe all safety information in this manual and safety decals on the equipment.

For service, your authorized Woods dealer has trained mechanics, genuine Woods service parts, and the necessary tools and equipment to handle all your needs.

Use only genuine Woods service parts. Substitute parts will void the warranty and may not meet standards required for safe and satisfactory operation. Record the model number and serial number of your equipment in the spaces provided:

Model: _____ **Date of Purchase:** _____

Serial Number: (see Safety Decal section for location) _____

Provide this information to your dealer to obtain correct repair parts.

Throughout this manual, the term **IMPORTANT** is used to indicate that failure to observe can cause damage to equipment. The terms **CAUTION**, **WARNING**, and **DANGER** are used in conjunction with the Safety-Alert Symbol (a triangle with an exclamation mark) to indicate the degree of hazard for items of personal safety.



This Safety-Alert Symbol indicates a hazard and means **ATTENTION! BECOME ALERT! YOUR SAFETY IS INVOLVED!**



DANGER

Indicates an imminently hazardous situation that, if not avoided, will result in death or serious injury.



WARNING

Indicates a potentially hazardous situation that, if not avoided, could result in death or serious injury, and includes hazards that are exposed when guards are removed.



CAUTION

Indicates a potentially hazardous situation that, if not avoided, may result in minor or moderate injury.

IMPORTANT

Indicates that failure to observe can cause damage to equipment.

NOTE

Indicates helpful information.

WOODS®

ALITEC™

BMP®

CENTRAL FABRICATORS®

GANNON®

GILL®

WAIN-ROY®

WOODS®

TABLE OF CONTENTS

INTRODUCTION.....	INSIDE FRONT COVER
SPECIFICATIONS.....	2
GENERAL INFORMATION.....	2
SAFETY VIDEO ORDER FORM.....	3A
SAFETY RULES.....	3-5
SAFETY DECALS.....	6-7
OPERATION.....	8
OWNER SERVICE.....	12
TROUBLE SHOOTING.....	17
DEALER SERVICE.....	18
DEALER CHECK LISTS.....	27
ASSEMBLY INSTRUCTIONS.....	28
INDEX TO PARTS LISTS.....	35
BOLT TORQUE CHART.....	50
BOLT SIZE CHART & ABBREVIATIONS.....	51
INDEX.....	52
PRODUCT WARRANTY.....	INSIDE BACK COVER
REPLACEMENT PARTS WARRANTY.....	BACK COVER

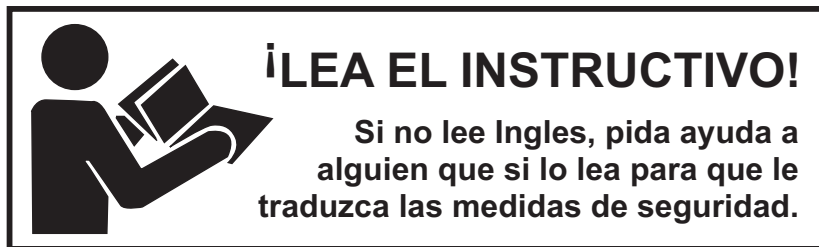

This Operator's Manual should be regarded as part of the machine. Suppliers of both new and second-hand machines must make sure that this manual is provided with the machine.

SPECIFICATIONS

3-Point Hitch	BB48, BB60, BB72; Category 1 or BB84; Category 2
Cutting Height	1" - 9"
Blade Spindle	1
Number of Blades	2
Blades	Heat Treated Alloy Steel
Blade Rotation	CCW
Tractor PTO RPM	540
Universal Drive	Category 3 or 4
Side Frame Thickness	10 Ga or 11 Ga
Tailwheel	4" x 16"

	<u>BB48</u>	<u>BB60</u>	<u>BB72</u>	<u>BB84</u>
Cutting Width	48"	60"	72"	84"
Overall Width	51.5"	63.5"	75.5"	87.5"
Weight (Approximate lbs.)	456 lbs	554 lbs	702 lbs	1000 lbs
Blade Speed (Feet per minute)	13,000	14,335	14,963	14,963
Gearbox	1:1.92	1:1.69	1:1.47	1:1.26
Recommended Maximum Tractor HP	15 - 50	25 - 50	30 - 65	35 - 90

GENERAL INFORMATION

WARNING

■ **Some illustrations in this manual show the cutter with safety shields removed to provide a better view. The cutter should never be operated with any safety shielding removed.**

The purpose of this manual is to assist you in operating and maintaining your cutter. Read it carefully. It furnishes information and instructions that will help you achieve years of dependable performance. These instructions have been compiled from extensive field experience and engineering data. Some information may be general in nature due to unknown and varying operating conditions. However, through experience and these instructions, you should be able to develop procedures suitable to your particular situation.

The illustrations and data used in this manual were current at the time of printing, but due to possible inline production changes, your machine may vary slightly in detail. We reserve the right to redesign and change the machines as may be necessary without notification.

Throughout this manual, references are made to right and left direction, These are determined by standing behind the equipment facing, the direction of forward travel. Blade rotation is counterclockwise as viewed from the top of the cutter.

BE SAFE!

BE ALERT!

BE ALIVE!

BE TRAINED

Before Operating Mowers!



ASSOCIATION OF
EQUIPMENT
MANUFACTURERS

*Safety Training
Does Make a Difference.*

Free Mower Safety Video

Fill out and return the order form and we will send you a FREE VHS or DVD video outlining ***Industrial and Agricultural Mower Safety Practices***. The 22 minute video, developed in cooperation with AEM (Association of Equipment Manufacturers), reinforces the proper procedures to follow while operating your Woods mowing equipment. The video does not replace the information contained in the Operator's Manual, so please review this manual thoroughly before operating your new mowing equipment.

Also, available from the Association of Equipment Manufacturers:

A large variety of training materials (ideal for groups) are available for a nominal charge from AEM. Following is a partial list:

- **Training Package for Rotary Mowers/Cutters-English**
Contains: DVD & VHS (English)
 Guidebook for Rotary Mowers/Cutters (English)
 AEM Industrial/Agricultural Mower Safety Manual (English)
 AEM Agricultural Tractor Safety Manual (English)

- **Training Package for Rotary Mowers/Cutters-English/Spanish**
Contains: DVD & VHS (English/Spanish)
 Guidebook for Rotary Mowers/Cutters (English/Spanish)
 AEM Industrial/Agricultural Mower Safety Manual (English/Spanish)
 AEM Agricultural Tractor Safety Manual (English/Spanish)

AEM training packages are available through:

AEM at: *www.aem.org*
or
Hubbard Publishing
800-369-2310 tel
608-846-3398 fax



Free Mower/Cutter Safety Video Order Form

Please send me (Select one)
 VHS Format - VHS01052 Safety Video
 DVD Format - DVD01052 Safety Video

Name: _____ Phone: _____

Address: _____

Mower/Cutter Model: _____ Serial #: _____

Send to: ATTENTION: DEALER SERVICES
 WOODS EQUIPMENT COMPANY
 PO BOX 1000
 OREGON IL 61061-1000

SAFETY RULES



ATTENTION! BECOME ALERT! YOUR SAFETY IS INVOLVED!



Safety is a primary concern in the design and manufacture of our products. Unfortunately, our efforts to provide safe equipment can be wiped out by an operator's single careless act.

In addition to the design and configuration of equipment, hazard control and accident prevention are dependent upon the awareness, concern, judgement, and proper training of personnel involved in the operation, transport, maintenance, and storage of equipment.

It has been said, "The best safety device is an informed, careful operator." We ask you to be that kind of operator.

TRAINING

- Safety instructions are important! Read all attachment and power unit manuals; follow all safety rules and safety decal information. (Replacement manuals and safety decals are available from your dealer. To locate your nearest dealer, check the Dealer Locator at www.WoodsEquipment.com, or in the United States and Canada call 1-800-319-6637.) Failure to follow instructions or safety rules can result in serious injury or death.
- If you do not understand any part of this manual and need assistance, see your dealer.
- Know your controls and how to stop engine and attachment quickly in an emergency.
- Operators must be instructed in and be capable of the safe operation of the equipment, its attachments, and all controls. Do not allow anyone to operate this equipment without proper instructions.
- Never allow children or untrained persons to operate equipment.

PREPARATION

- Check that all hardware is properly installed. Always tighten to torque chart specifications unless instructed otherwise in this manual.
- Always wear relatively tight and belted clothing to avoid getting caught in moving parts. Wear sturdy, rough-soled work shoes and protective equipment for eyes, hair, hands, hearing, and head; and respirator or filter mask where appropriate.
- Make sure attachment is properly secured, adjusted, and in good operating condition.

- Make sure spring-activated locking pin or collar slides freely and is seated firmly in tractor PTO spline groove.

- Make sure driveline guard tether chains are attached to the tractor and equipment as shown in the pamphlet that accompanies the driveline. Replace if damaged or broken. Check that driveline guards rotate freely on driveline before putting equipment into service.

- Before starting power unit, check all equipment driveline guards for damage. Replace any damaged guards. Make sure all guards rotate freely on all drivelines. If guards do not rotate freely on drivelines, repair and replace bearings before putting equipment into service.

- Power unit must be equipped with ROPS or ROPS cab and seat belt. Keep seat belt securely fastened. Falling off power unit can result in death from being run over or crushed. Keep foldable ROPS system in "locked up" position at all times.

- Inspect chain, rubber, or steel band shielding before each use. Replace if damaged.

- Remove accumulated debris from this equipment, power unit, and engine to avoid fire hazard.

- Make sure all safety decals are installed. Replace if damaged. (See Safety Decals section for location.)

- Make sure shields and guards are properly installed and in good condition. Replace if damaged.

- A minimum 20% of tractor and equipment weight must be on the tractor front wheels when attachments are in transport position. Without this weight, tractor could tip over, causing personal injury or death. The weight may be attained with a loader, front wheel weights, ballast in tires or front tractor weights. Weigh the tractor and equipment. Do not estimate.

- Inspect and clear area of stones, branches, or other hard objects that might be thrown, causing injury or damage.

OPERATION

- Do not allow bystanders in the area when operating, attaching, removing, assembling, or servicing equipment.

(Safety Rules continued on next page)



SAFETY RULES

ATTENTION! BECOME ALERT! YOUR SAFETY IS INVOLVED!



(Safety Rules continued from previous page)

- Full chain, rubber, or steel band shielding, designed to reduce the possibility of thrown objects, must be installed when operating in populated areas or other areas where thrown objects could injure people or damage property. If this machine is not equipped with full chain, rubber, or steel band shielding, operation must be stopped when anyone comes within several hundred feet.
- Never direct discharge toward people, animals, or property.
- Do not operate or transport equipment while under the influence of alcohol or drugs.
- Operate only in daylight or good artificial light.
- Keep hands, feet, hair, and clothing away from equipment while engine is running. Stay clear of all moving parts.
- Always comply with all state and local lighting and marking requirements.
- Never allow riders on power unit or attachment.
- Power unit must be equipped with ROPS or ROPS cab and seat belt. Keep seat belt securely fastened. Falling off power unit can result in death from being run over or crushed. Keep foldable ROPS system in “locked up” position at all times.
- Always sit in power unit seat when operating controls or starting engine. Securely fasten seat belt, place transmission in neutral, engage brake, and ensure all other controls are disengaged before starting power unit engine.
- Operate tractor PTO at 540 RPM. Do not exceed.
- Do not operate PTO during transport.
- Look down and to the rear and make sure area is clear before operating in reverse.
- Do not operate or transport on steep slopes.
- Do not stop, start, or change directions suddenly on slopes.
- Use extreme care and reduce ground speed on slopes and rough terrain.
- Watch for hidden hazards on the terrain during operation.
- Stop power unit and equipment immediately upon striking an obstruction. Turn off engine, remove key, inspect, and repair any damage before resuming operation.

- Leak down or failure of mechanical or hydraulic system can cause equipment to drop.

- Before performing any service or maintenance, disconnect driveline from tractor PTO.

MAINTENANCE

- Before performing any service or maintenance, disconnect driveline from tractor PTO.

- Before working underneath, disconnect driveline, raise cutter, and block cutter securely. Hydraulic system leak down and failure of mechanical or hydraulic system can cause equipment to drop.

- Do not modify or alter or permit anyone else to modify or alter the equipment or any of its components in any way.

- Always wear relatively tight and belted clothing to avoid getting caught in moving parts. Wear sturdy, rough-soled work shoes and protective equipment for eyes, hair, hands, hearing, and head; and respirator or filter mask where appropriate.

- Make sure attachment is properly secured, adjusted, and in good operating condition.

- Do not allow bystanders in the area when operating, attaching, removing, assembling, or servicing equipment.

- Keep all persons away from operator control area while performing adjustments, service, or maintenance.

- Make certain all movement of equipment components has stopped before approaching for service.

- Frequently check blades. They should be sharp, free of nicks and cracks, and securely fastened.

- Do not handle blades with bare hands. Careless or improper handling may result in serious injury.

- Your dealer can supply genuine replacement blades. Substitute blades may not meet original equipment specifications and may be dangerous.

- Tighten all bolts, nuts, and screws to torque chart specifications. Check that all cotter pins are installed securely to ensure equipment is in a safe condition before putting unit into service.

- Make sure all safety decals are installed. Replace if damaged. (See Safety Decals section for location.)

SAFETY RULES



ATTENTION! BECOME ALERT! YOUR SAFETY IS INVOLVED!



- Make sure shields and guards are properly installed and in good condition. Replace if damaged.
- Leak down or failure of mechanical or hydraulic system can cause equipment to drop.

- Disconnect cutter driveshaft and secure up off ground. Raise cutter with 3-point hitch. Place blocks under cutter side skids. Lower cutter onto blocks. Disconnect cutter from tractor 3-point hitch and carefully drive tractor away from cutter.

STORAGE

- Keep children and bystanders away from storage area.



SAFETY & INSTRUCTIONAL DECALS



ATTENTION! BECOME ALERT! YOUR SAFETY IS INVOLVED!



Replace Immediately If Damaged!

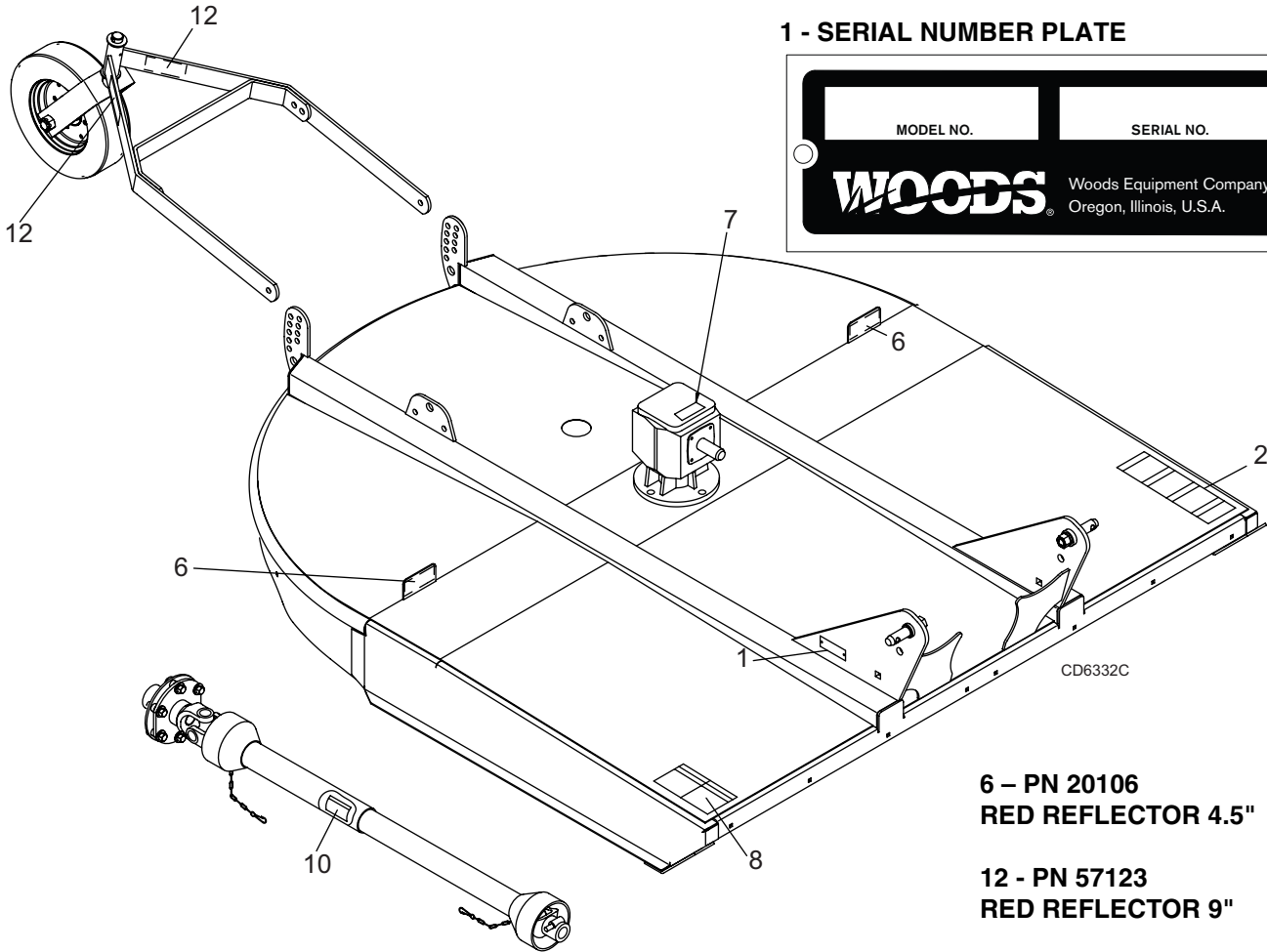

1 - SERIAL NUMBER PLATE



CD6332C

6 - PN 20106
RED REFLECTOR 4.5"

12 - PN 57123
RED REFLECTOR 9"

8 - PN 1006682

! DANGER

**ROTATING BLADES AND
THROWN OBJECTS**

- Do not put hands or feet under or into mower when engine is running.
- Before mowing, clear area of objects that may be thrown by blade.
- Keep bystanders away.
- Keep guards in place and in good condition.

**BLADE CONTACT OR THROWN OBJECTS CAN CAUSE
SERIOUS INJURY OR DEATH.**

! DANGER

**ROTATING DRIVELINE
CONTACT CAN CAUSE DEATH
KEEP AWAY!**

DO NOT OPERATE WITHOUT -

- All driveline guards, tractor and equipment shields in place
- Drivelines securely attached at both ends
- Driveline guards that turn freely on driveline

1006682-A

SAFETY & INSTRUCTIONAL DECALS



ATTENTION! BECOME ALERT! YOUR SAFETY IS INVOLVED!



Replace Immediately If Damaged!

BE CAREFUL!

Use a clean, damp cloth to clean safety decals.

Avoid spraying too close to decals when using a pressure washer; high-pressure water can enter through very small scratches or under edges of decals causing them to peel or come off.

Replacement safety decals can be ordered free from your Woods dealer. To locate your nearest dealer, check the Dealer Locator at www.WoodsEquipment.com, or in the United States and Canada call 1-800-319-6637.

7 - PN 1004114

⚠ DANGER
If shaft connection is visible, shield is missing. Replace shield before operating equipment. 1004114

10 - PN 33347

⚠ DANGER

GUARD MISSING. DO NOT OPERATE.
⚠ DANGER

GUARD MISSING. DO NOT OPERATE. 33347E
⚠ DANGER

2 - 1006681

⚠ WARNING

CRUSHING AND PINCHING HAZARD
<ul style="list-style-type: none"> ■ Be extremely careful handling various parts of the machine. They are heavy and hands, fingers, feet, and other body parts could be crushed or pinched between tractor and implement. ■ Operate tractor controls from tractor seat only. ■ Do not stand between tractor and implement when tractor is in gear. ■ Make sure parking brake is engaged before going between tractor and implement. ■ Stand clear of machine while in operation or when it is being raised or lowered. <p style="text-align: center;">FAILURE TO FOLLOW THESE INSTRUCTIONS COULD RESULT IN SERIOUS INJURY OR DEATH.</p>

⚠ WARNING
TO AVOID SERIOUS INJURY OR DEATH:
<ul style="list-style-type: none"> ■ Read Operator's Manual (available from dealer) and follow all safety precautions. ■ Keep all shields in place and in good condition. ■ Operate mower from tractor seat only. ■ Lower mower, stop engine and remove key before dismantling tractor. ■ Allow no children or untrained persons to operate equipment. ■ Do not transport towed or semi-mounted units over 20 mph. <p style="text-align: center;">FAILURE TO OPERATE SAFELY CAN RESULT IN INJURY OR DEATH.</p>

⚠ WARNING

FALLING OFF CAN RESULT IN BEING RUN OVER.
<ul style="list-style-type: none"> ■ Tractor must be equipped with ROPS (or ROPS CAB) and seat belt. Keep foldable ROPS systems in "locked up" position at all times. ■ Buckle Up! Keep seat belt securely fastened. ■ Allow no riders. <p style="text-align: center;">RAISED EQUIPMENT CAN DROP AND CRUSH.</p> <ul style="list-style-type: none"> ■ Before working underneath, follow all instructions and safety rules in operator's manual and securely block up all corners of equipment with jack stands. ■ Securely blocking prevents equipment from dropping from hydraulic leakdown, hydraulic system failures or mechanical component failures. <p style="text-align: center;">FALLING OFF OR FAILING TO BLOCK SECURELY CAN RESULT IN SERIOUS INJURY OR DEATH.</p>

⚠ WARNING
DO NOT EXCEED PTO SPEED OF 540 RPM
PTO speeds higher than 540 RPM can cause equipment failure and personal injury. 1006681

OPERATION

The operator is responsible for the safe operation of the cutter. The operator must be properly trained. Operators should be familiar with the cutter, the tractor, and all safety practices before starting operation. Read the safety rules and safety decals on pages 3 to 7.

This standard-duty cutter is designed for grass and weed mowing and shredding.

Recommended mowing speed for most conditions is from 2 to 5 mph.

! DANGER

■ Full chain, rubber, or steel band shielding, designed to reduce the possibility of thrown objects, must be installed when operating in populated areas or other areas where thrown objects could injure people or damage property. If this machine is not equipped with full chain, rubber, or steel band shielding, operation must be stopped when anyone comes within several hundred feet.

! WARNING

- Never allow riders on power unit or attachment.
- Keep bystanders away from equipment.
- Make sure spring-activated locking pin or collar slides freely and is seated firmly in tractor PTO spline groove.
- Operate tractor PTO at 540 RPM. Do not exceed.

! CAUTION

- Stop power unit and equipment immediately upon striking an obstruction. Turn off engine, remove key, inspect, and repair any damage before resuming operation.
- Always wear relatively tight and belted clothing to avoid getting caught in moving parts. Wear sturdy, rough-soled work shoes and protective equipment for eyes, hair, hands, hearing, and head; and respirator or filter mask where appropriate.

TRACTOR STABILITY

! WARNING

■ A minimum 20% of tractor and equipment weight must be on the tractor front wheels when attachments are in transport position. Without this weight, tractor could tip over, causing personal injury or death. The weight may be attained with a

loader, front wheel weights, ballast in tires or front tractor weights. Weigh the tractor and equipment. Do not estimate.

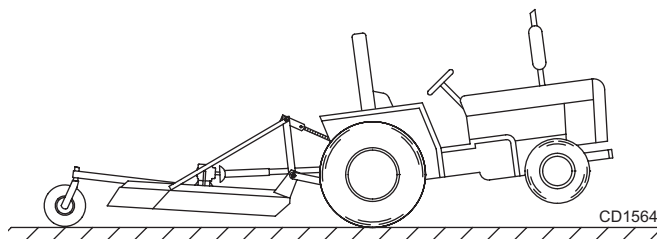

Figure 1. Tractor Stability

ATTACH CUTTER TO TRACTOR

! WARNING

- Make sure spring-activated locking pin or collar slides freely and is seated firmly in tractor PTO spline groove.
- Make sure driveline will not bottom out at the shortest length and that it has at least 1/3 overlap at the longest length.
- With cutter adjusted to transport position, set upper stop on tractor lift quadrant to prevent cutter from contacting the driveline when being raised.
- Select a top link mounting pin (maximum length 3-5/8") that will allow floating link to swing freely through the cutter A-frame bars.
 1. Attach tractor 3-point lift arms to the cutter hitch pins and secure.
 2. Attach tractor top link to cutter clevis using forward hole. Select a top link mounting pin that will allow floating link to swing freely through the cutter A-frame bars.

NOTE: You will need to adjust the top link; refer to **Adjust Top Link, page 9.**
 3. Connect driveline to tractor PTO shaft.

NOTE: The standard 1-3/8" 6B spline driveline with a QD yoke is used to connect the cutter to the tractor.
 4. Adjust the tractor lower 3-point arm anti-sway devices to prevent cutter from swinging side to side during transport.
 5. Adjust tractor drawbar so that it will not interfere with cutter or driveline.
 6. Slowly raise and lower cutter to check driveline length.

SHREDDING MATERIAL

For shredding, set the cutter lower at rear. Determine how much lower to set the rear by experimenting in different situations.

ADJUST CUTTING HEIGHT

! WARNING

■ **Keep all persons away from operator control area while performing adjustments, service, or maintenance.**

■ **Avoid low cutting heights. Striking the ground with blades produces one of the most damaging shock loads a cutter can encounter. Allowing blades to contact ground repeatedly will cause damage to cutter and drive.**

1. Level cutter from side to side. Check by measuring from cutter frame to the ground at each deck rail.

2. Adjust, using tractor 3-point arm leveling device.

NOTE: Keep the front of cutter slightly lower than rear for best mowing.

3. Control cutting height with tractor 3-point arms, rear tailwheel adjustment, or optional check chains.

4. To raise rear of cutter, move tailwheel arm down.

5. To raise front of cutter, raise tractor 3-point arms or shorten optional check chains.

The cutting height is the distance between the blade and the ground. The blades are approximately 8.5" below the deck. To check cutting height, do the following:

a) Place a straight edge along top edge of deck.

b) Select a cutting height; as an example, for an approximate cutting height of 3", set the center of the deck 11.5" above the ground:

$$\begin{array}{r} 3" \text{ Desired cutting height} \\ + 8.5" \text{ Distance blade cutting edge is below deck} \\ \hline = 11.5" \end{array}$$

c) Adjust the front-to-rear attitude from 1/2" to 3/4" higher than the front.

ADJUST TOP LINK

Refer to Figure 2.

IMPORTANT

■ **When cutter is adjusted to transport position, set upper stop on tractor lift quadrant to prevent cutter from contacting the driveline when being raised.**

IMPORTANT

■ **Select a top link mounting pin (maximum length 3-5/8") that will allow floating link to swing freely through the cutter A-frame bars.**

1. Attach tractor top link (1) to lowest hole provided in the tractor's top link bracket (6).

2. Attach rear portion of tractor top link to the first hole on the cutter floating link (3). Select a top link mounting pin that will allow the floating link to swing freely through the cutter A-frame bars (5).

3. Raise cutter to transport position and adjust tractor top link until cutter is level in the raised position.

NOTE: If you cannot level the cutter using the lowest hole in the tractor's top link bracket, move top link to the next hole and level the cutter.

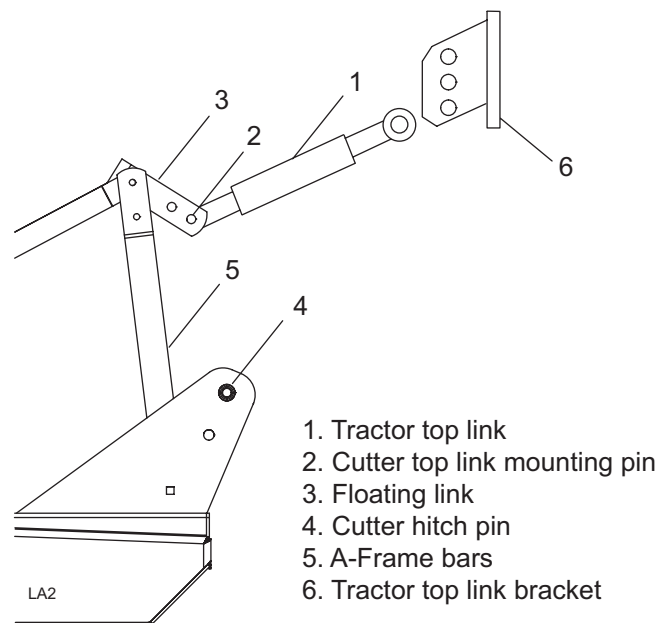

Figure 2. Top Link Adjustment (BB72 and BB84 Shown)

ATTACH QUICK HITCH

Refer to Figure 4.

IMPORTANT

■ **When cutter is adjusted to transport position, set upper stop on tractor lift quadrant to prevent cutter from contacting the driveline when being raised.**

1. Remove brace arms (6), floating link (3), cap screw (11), spacer (7), and flange lock nut (9) from upper hole on A-frame bars (5) as shown in Figure 4.

NOTE: A-frame bar(s) are installed to mast plates with carriage bolts through the square holes.

2. Attach open end of floating link (3) to the bottom hole of A-frame bars (5). Secure using cap screw (11), sleeve (10), and flange lock nut (9).
 3. Attach closed end of floating link (3) to diagonal braces (6). Secure using cap screw (8), spacer (7), and flange lock nut (9) supplied in hardware bag.
- NOTE:** Quick hitch top hook will pick up on sleeve (10). Lower quick hitch hook will attach to cutter hitch pins.
4. Raise cutter to transport position and adjust tractor top link until cutter is level in the raised position.

INSTALLATION AND REMOVAL OF DRIVELINE (TRACTOR PTO)

To Install:

Pull locking collar back and at the same time push driveline onto tractor PTO shaft until locking device engages.

To Remove:

Hold driveline into position, pull locking collar back, and slide driveline off tractor PTO shaft.

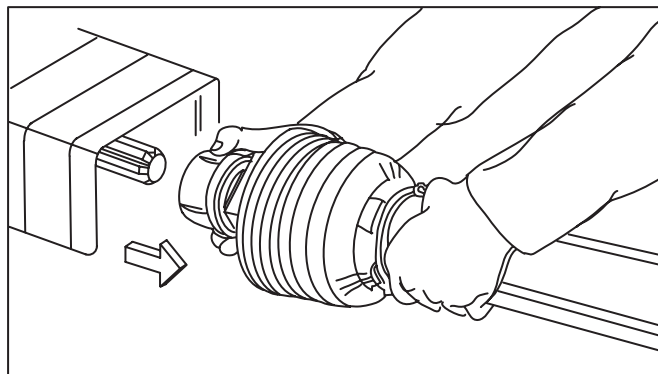
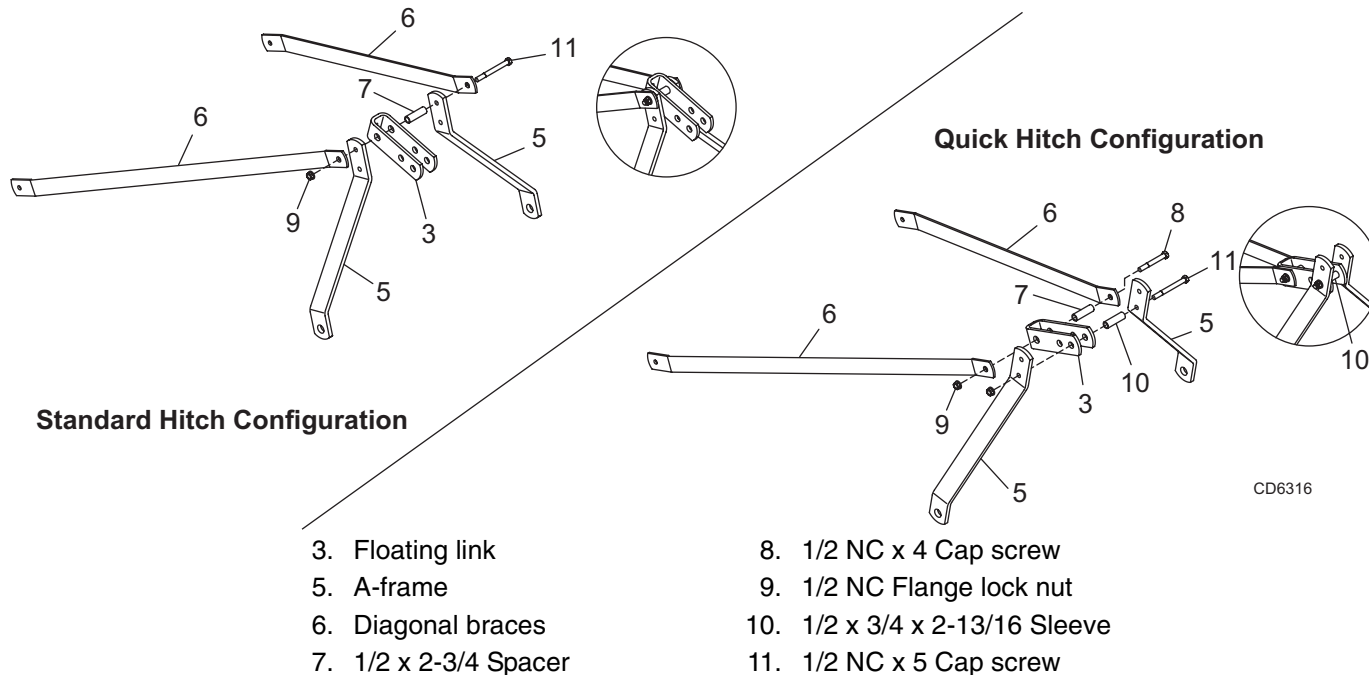

Figure 3. Lock Collar



CD6316

Figure 4. Standard Hitch and Quick Hitch Configuration

ADJUST CHECK CHAINS

1. Refer to **Install Optional Check Chains, page 33** for check chain installation.
2. After making cutting height adjustment, adjust both chains (3) in check chain bracket (2) so you have the same number of links on each side. This will keep cutting level.

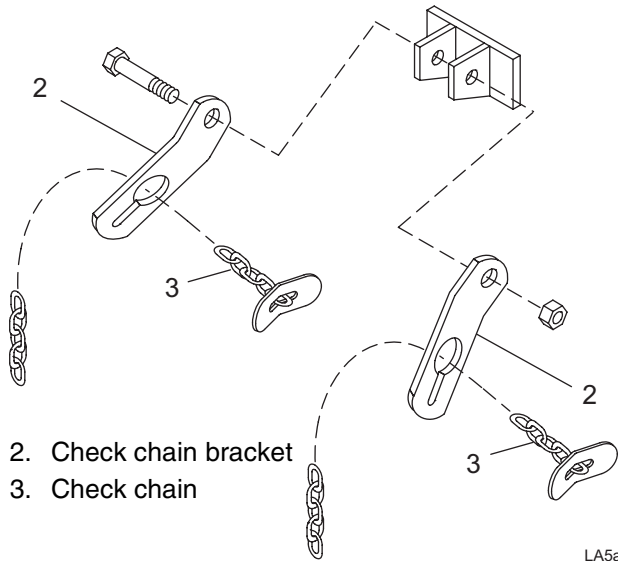

Figure 5. Check Chain Adjustment

OPERATING TECHNIQUE

1. Power for operating the cutter is supplied by the tractor PTO. Operate PTO at 540 rpm. Know how to stop the tractor and cutter quickly in an emergency.
2. Engage PTO at a low engine rpm to minimize stress on the drive system and gearbox. With PTO engaged, raise PTO speed to 540 rpm and maintain throughout cutting operation.

Gearbox protection is provided by a slip clutch with replacement fiber disc or a shear bolt. The slip clutch is designed to slip and the shear bolt will shear when excessive torsion loads occur.

3. Move slowly into material. Adjust tractor ground speed to provide a clean cut without lugging the tractor engine. Use a slow ground speed for better shredding.

Proper ground speed will depend on the terrain and the material's height, type, and density.

Normally, ground speed will range from 2 to 5 mph. Tall, dense material should be cut at a low speed; thin, medium-height material can be cut at a faster ground speed.

4. Always operate tractor PTO at 540 rpm to maintain proper blade speed and to produce a clean cut.
5. Under certain conditions tractor tires may roll down some grass and prevent cutting at the same height as the surrounding area. When this occurs, reduce your ground speed but maintain PTO at 540 rpm. The lower ground speed will permit grass to rebound partially.

STORAGE

⚠ WARNING

■ **Disconnect cutter driveshaft and secure up off ground. Raise cutter with 3-point hitch. Place blocks under cutter side skids. Lower cutter onto blocks. Disconnect cutter from tractor 3-point hitch and carefully drive tractor away from cutter.**

■ **Keep children and bystanders away from storage area.**

PRE-OPERATION CHECK LIST **OWNER'S RESPONSIBILITY**

- ___ Review and follow all safety rules and safety decal instructions on pages 3 through 7.
- ___ Check that equipment is properly and securely attached to tractor.
- ___ Make sure driveline spring-activated locking pin or collar slides freely and is seated firmly in tractor PTO spline groove.
- ___ Set tractor PTO at 540 rpm.
- ___ Lubricate all grease fitting locations. Make sure PTO shaft slip joint is lubricated.
- ___ Check to be sure gear lube runs out the small check plug on side of gearbox.
- ___ Check that all hardware is properly installed and secured.
- ___ Check that blades are sharp and secure and cutting edge is positioned to lead in a counter-clockwise rotation.
- ___ Check that shields and guards are properly installed and in good condition. Replace if damaged.
- ___ Check cutting height, front-to-rear attitude, and top link adjustment.
- ___ Place tractor PTO and transmission in neutral before starting engine.
- ___ Inspect area to be cut and remove stones, branches, or other hard objects that might be thrown and cause injury or damage.

OWNER SERVICE

The information in this section is written for operators who possess basic mechanical skills. If you need help, your dealer has trained service technicians available. For your protection, read and follow the safety information in this manual

WARNING

■ **Keep all persons away from operator control area while performing adjustments, service, or maintenance.**

CAUTION

■ **If you do not understand any part of this manual and need assistance, see your dealer.**

■ **Always wear relatively tight and belted clothing to avoid getting caught in moving parts. Wear sturdy, rough-soled work shoes and protective equipment for eyes, hair, hands, hearing, and head; and respirator or filter mask where appropriate.**

BLOCKING METHOD

WARNING

■ **Before performing any service or maintenance, disconnect driveline from tractor PTO.**

■ **Never go underneath equipment (lowered to the ground or raised) unless it is properly blocked and secured. Never place any part of the body underneath equipment or between moveable parts even when the engine has been turned off. Hydraulic system leak down, hydraulic system failures,**

mechanical failures, or movement of control levers can cause equipment to drop or rotate unexpectedly and cause severe injury or death. Follow Operator's Manual instructions for working underneath and blocking requirements or have work done by a qualified dealer.

To minimize the potential hazards of working underneath the cutter, follow these procedures.

1. Jackstands with a load rating of 1000 lbs. or more are the only approved blocking device for this cutter. Install a minimum of four jackstands (shown by Xs in Figure 5) under the cutter before working underneath unit.

Do not position jackstands under wheels, axles, or wheel supports. Components can rotate and cause cutter to fall.

2. Consider the overall stability of the blocked unit. Just placing jackstands underneath will not ensure your safety.

The working surface must be level and solid to support the weight on the jackstands. Make sure jackstands are stable, both top and bottom. Make sure cutter is approximately level.

3. With full cutter weight lowered onto jackstands, test blocking stability before working underneath.
4. If cutter is attached to tractor when blocking, set the brakes, remove key, and block cutter before working underneath.
5. Securely block rear tractor wheels, in front and behind. Tighten tractor lower 3-point arm anti-sway mechanism to prevent side-to-side movement.

LUBRICATION INFORMATION

1. Do not let excess grease collect on or around parts, particularly when operating in sandy areas.
2. See Figure 5 for lubrication points and frequency of lubrication based on normal operating conditions. Severe or unusual conditions may require more frequent lubrication.
3. Use a lithium grease of #2 consistency with a MOLY (molybdenum disulfide) additive for all locations unless otherwise noted. Be sure to clean fittings thoroughly before attaching grease gun. One good pump of most guns is sufficient when the lubrication schedule is followed.

Gearbox Lubrication

4. For gearbox, use a high quality gear oil with a viscosity index of 80W or 90W and an API service rating of GL-4 or -5 in gearboxes.

5. Fill gearbox until oil runs out the side plug on gearbox. Check gearbox daily for evidence of leakage, and contact your dealer if leakage occurs.

Driveline Lubrication

1. Lubricate the driveline slip joint every eight operating hours. Failure to maintain proper lubrication could result in damage to U-joints, gearbox, and driveline.
2. Lower cutter to ground, disconnect driveline from tractor PTO shaft, and slide halves apart but do not disconnect from each other.
3. Apply a bead of grease completely around male half where it meets female half. Slide drive halves over each other several times to distribute grease.

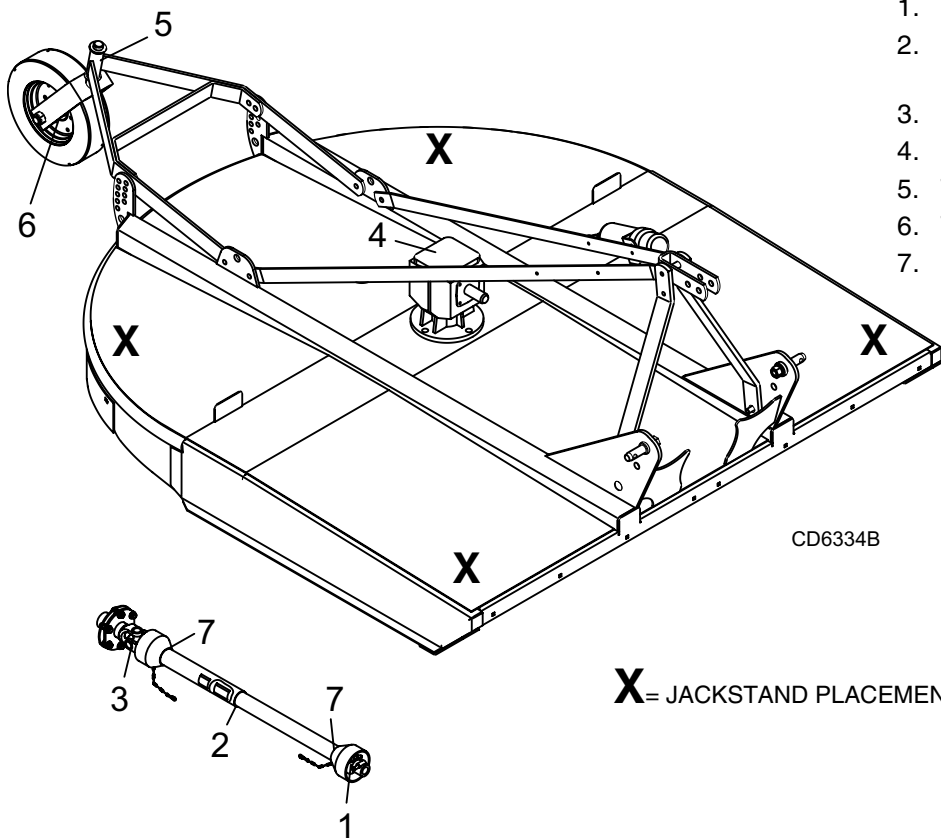

1. Front U-joint - - - - - 8 hrs.
2. Slip joint (apply grease to square shaft) - 8 hrs.
3. Rear U-joint - - - - - 8 hrs.
4. Gearbox - - - - - Daily
5. Tailwheel pivot tube - - - - 8 hrs.
6. Tailwheel - - - - - 8 hrs.
7. Plastic shield bearings - - 8 hrs.

CD6334B

X = JACKSTAND PLACEMENT

Figure 5. Jackstand Placement and Lubrication Points

SERVICE BLADES

Remove Blades

IMPORTANT

■ If blade pin (1) is seized in crossbar and extreme force will be needed to remove it, support crossbar from below to prevent gearbox damage.

1. Disconnect driveline from tractor PTO.
2. Raise cutter and block securely (see Figure 5).
3. Align crossbar (3) with blade access hole in the cutter frame. Remove nut (5) and lock washer (4) using a 1-11/16" socket. Carefully drive pin (1) out of crossbar.

4. Rotate crossbar (3) and repeat for opposite blade.

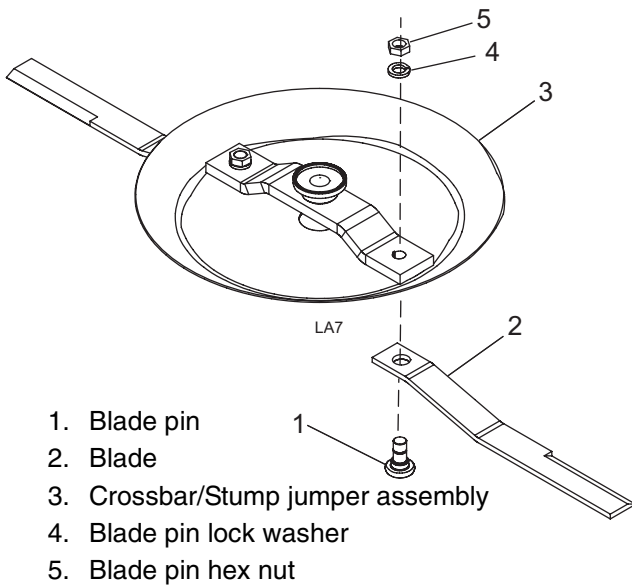

Figure 6. Blade Assembly

Install Blades

Refer to Figure 6.

CAUTION

■ Your dealer can supply genuine replacement blades. Substitute blades may not meet original equipment specifications and may be dangerous.

■ Crossbar rotation is counterclockwise when looking down on cutter. Be sure to install blade cutting edge to lead in counterclockwise rotation.

IMPORTANT

■ Always replace or sharpen both blades at the same time.

1. Inspect blade pin (1) for nicks or gouges, and if you find any replace the pin.
2. Insert pin through the blade. Blade should swivel on bolt; if it doesn't determine the cause and correct.
3. Align crossbar (3) with blade access hole in cutter frame. Apply a liberal coating of Never-Seez® or equivalent to blade pin and crossbar hole. Make sure blade offset is away from cutter.
4. Insert blade pin (1) through blade. Align key on blade pin with keyway in crossbar and push blade pin through crossbar.
5. Insert lock washer (4) and nut (5) through blade access hole in the cutter frame. Install on blade pin (1) and tighten to 450 lbs-ft using a 1-11/16" socket.

Sharpen Blades

IMPORTANT

■ When sharpening blades, grind the same amount on each blade to maintain balance. Replace blades in pairs. Unbalanced blades will cause excessive vibration, which can damage gearbox bearings. Vibration may also cause structural cracks to cutter.

1. Sharpen both blades at the same time to maintain balance. Follow original sharpening pattern.
2. Do not sharpen blade to a razor edge—leave at least a 1/16" blunt edge.
3. Do not sharpen back side of blade.

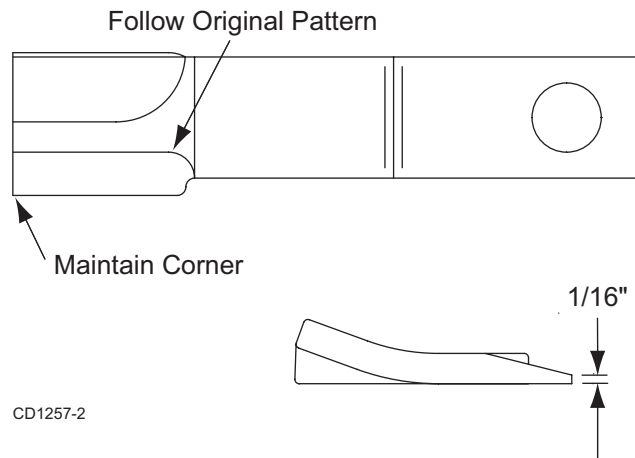

Figure 7. Sharpen Blade

ADJUST SLIP CLUTCH

The slip clutch is designed to slip so that the gearbox and driveline are protected if the cutter strikes an obstruction.

A new slip clutch or one that has been in storage over the winter may seize. Before operating the cutter, make sure it will slip by performing the following operation:

(Walterschied)

1. Turn off tractor engine and remove key.
2. Remove driveline from tractor PTO.
3. Loosen six 10 mm cap screws (6) to remove all tension from Belleville spring plate (5).
4. Hold clutch hub (3) solid and turn shaft to make sure clutch slips.
5. If clutch does not slip freely, disassemble and clean the thrust plate faces (4), flange yoke (1), and clutch hub (3).
6. Reassemble clutch.
7. Tighten Belleville spring (5) until it is against the thrust plate (4) of the clutch, and then back off each

of the six nuts by two full revolutions. The gap between Belleville spring and thrust plate should be 1/8" as shown in Figure 8.

8. If a clutch continues to slip when the spring is compressed to 1/8", check friction discs (2) for excessive wear. Discs are 1/8" when new. Replace discs after 1/16" wear. Minimum disc thickness is 1/16".

(Comer)

1. Turn off tractor engine and remove key.
2. Loosen nuts on springs until the springs can rotate freely, yet remain secure on the bolts.
3. Mark outer plates of slip-disc clutch as shown in Figure 8.
4. Securely attach implement to the tractor and start the tractor.

5. Engage PTO for several seconds then quickly disengage it.
6. Turn tractor off and remove key.
7. The friction lining plates should have "slipped". Check the marks placed on the outer plates of the slip-disc clutch in step 3 to make sure this is the case.
8. If clutch does not slip check assembly for oil, grease and debris. Clean if necessary.
9. Reassemble clutch and tighten bolts no more than 1/8 of a turn at a time until desired setting of 1.26" as shown in Figure 8.
10. If excessive slippage continues check lining plates for excessive wear. They are 1/8" thick when new and should be replaced after 1/32" of wear to ensure proper operation.

Walterschied

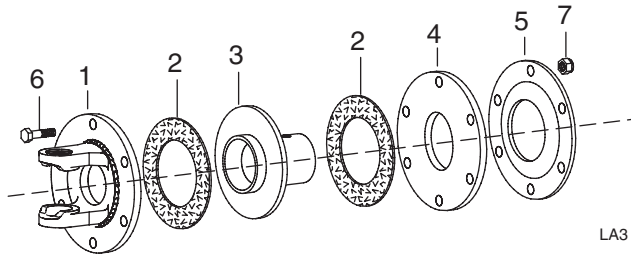

1. Flange yoke
2. Friction disc
3. Hub, 1-3/8 round bore
4. Thrust plate
5. Belleville spring plate
6. 10 mm x 1.35P x 50 mm Cap screw
7. 10 mm x 1.5P Hex nut

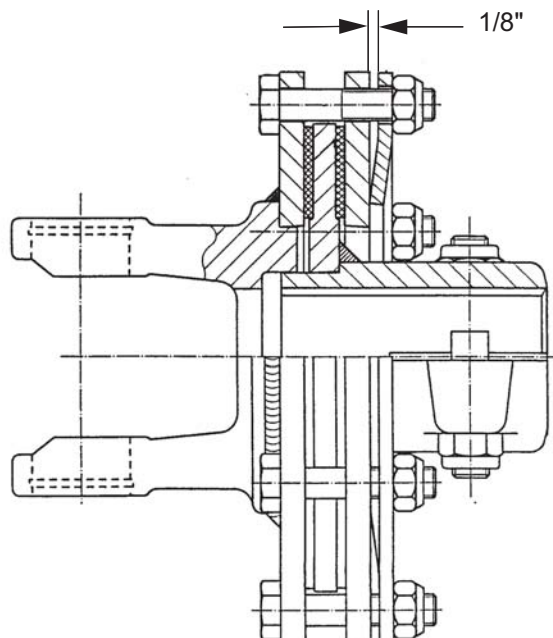

Comer

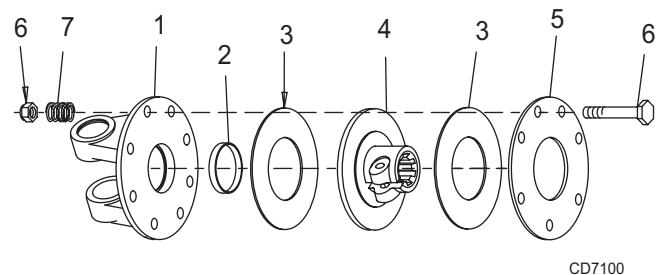

1. Flange yoke
2. Bushing
3. Lining ring
4. Flanged hub F12
5. Pressure plate
6. Bolt and nut M10 x 80
7. Spring

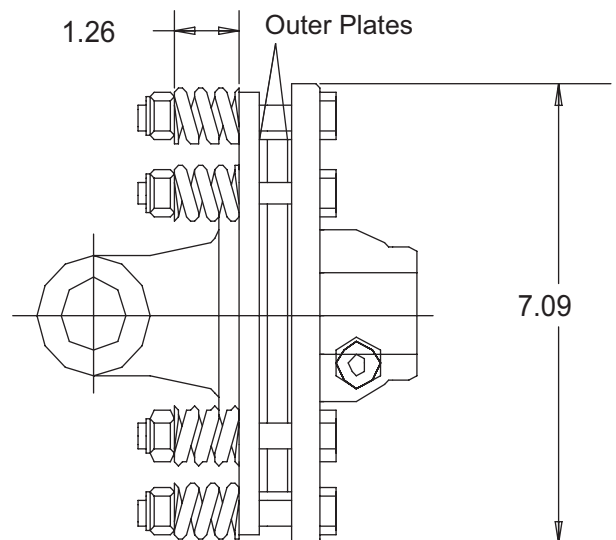

Figure 8. Slip Clutch Assembly

REPLACE DRIVELINE SHEAR BOLTS

IMPORTANT

■ Always use approved 1/2" NC x 3" grade 2 shear bolt as a replacement part. Using a hardened bolt or shear pin may result in damage to driveline or gearbox.

1. Remove driveline shield bell (1).
2. Remove damaged shear bolt (4).
3. Rotate driveline to align holes in yoke and shaft. Install shear bolt and secure with lock nut. Replace driveline shield bell.

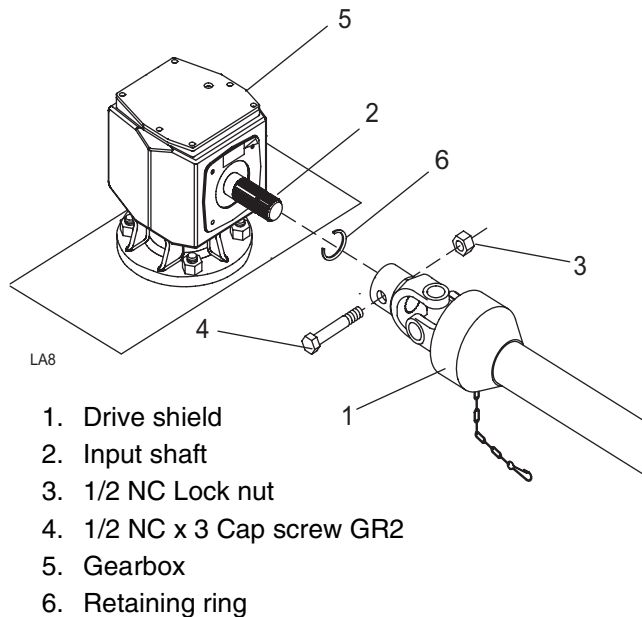

Figure 9. Shear Bolt Driveline Assembly

REPAIR SHIELDING

⚠ DANGER

■ Full chain, rubber, or steel band shielding, designed to reduce the possibility of thrown objects, must be installed when operating in populated areas or other areas where thrown objects could injure people or damage property. If this machine is not equipped with full chain, rubber, or

steel band shielding, operation must be stopped when anyone comes within several hundred feet.

Repair Rear Band

Inspect rear band each day of operation and replace if bent, cracked or broken.

Repair Optional Rubber Shielding

Inspect rubber shielding each day of operation and replace if cracked or broken.

Repair Optional Chain Shielding

Inspect chain shielding each day of operation and replace any broken or missing chains as required.

CLEANING

After Each Use

- Remove large debris such as clumps of dirt, grass, crop residue, etc. from machine.
- Inspect machine and replace worn or damaged parts.
- Replace any safety decals that are missing or not readable.

Periodically or Before Extended Storage

- Clean large debris such as clumps of dirt, grass, crop residue, etc. from machine.
- Remove the remainder using a low-pressure water spray.
 1. Be careful when spraying near scratched or torn safety decals or near edges of decals as water spray can peel decal off surface.
 2. Be careful when spraying near chipped or scratched paint as water spray can lift paint.
 3. If a pressure washer is used, follow the advice of the pressure washer manufacturer.
- Inspect machine and replace worn or damaged parts.
- Sand down scratches and the edges of areas of missing paint and coat with Woods spray paint of matching color (purchase from your Woods dealer).
- Replace any safety decals that are missing or not readable (supplied free by your Woods dealer). See Safety Decals section for location drawing.

TROUBLE SHOOTING

MOWING CONDITIONS

PROBLEM	POSSIBLE CAUSE	SOLUTION
Grass cut lower in center of swath than at edge	Height of cutter lower at rear or front	Adjust cutter height and attitude so that cutter rear and front are within 1/2" of same height.
Streaking conditions in swath	Conditions too wet for mowing	Allow grass to dry before mowing.
	Blades unable to cut that part of grass pressed by path of tractor tires	Slow ground speed of tractor but keep engine running at full PTO RPM. Cutting lower will help.
	Dull blades	Sharpen or replace blades.
Material discharges from cutter unevenly; bunches of material along swath	Material too high and too much material	Reduce ground speed but maintain 540 RPM at tractor PTO or make two passes over material. Raise cutter for the first pass and lower to desired height for the second and cut at 90° to first pass. Raise rear of cutter high enough to permit material to discharge but not so high as to cause conditions listed above.
	Grass wet	Allow grass to dry before mowing. Slow ground speed of tractor but keep engine running at full PTO RPM. Cutting lower will help.
	Rear of cutter too low, trapping material under cutter	Adjust cutter height and attitude.
Cutter will not cut (Shear bolt drive only)	Shear bolt sheared	Install new shear bolt.
Cutter will not cut all the time (Slip clutch drive only)	Slip clutch slipping	Adjust slip clutch according to instructions in Adjust Slip Clutch, page 14.

DEALER SERVICE

The information in this section is written for dealer service personnel. The repair described here requires special skills and tools. If your shop is not properly equipped or your mechanics are not properly trained in this type of repair, you may be time and money ahead to replace complete assemblies.

⚠ WARNING

■ Before working underneath, disconnect driveline, raise cutter, lock in transport position, and block cutter securely. Hydraulic system leak down and failure of mechanical or hydraulic system can cause equipment to drop.

■ Keep all persons away from operator control area while performing adjustments, service, or maintenance.

⚠ CAUTION

■ Always wear relatively tight and belted clothing to avoid getting caught in moving parts. Wear sturdy, rough-soled work shoes and protective equipment for eyes, hair, hands, hearing, and head; and respirator or filter mask where appropriate.

GEARBOX MAINTENANCE

NOTE: Read this entire section before starting any repair. Many steps are dependent on each other.

1. Fill gearbox with SAE 80W or 90W gear lube until it runs out the side level plug.

NOTE: Repair to this gearbox is limited to replacing bearings, seals, and gaskets. Replacing gears, shafts, and a housing is not cost effective. Purchasing a complete gearbox is more economical.

2. Inspect gearbox for leakage and bad bearings. Leakage is a very serious problem and must be corrected immediately. Bearing failure is indicated by excessive noise and side-to-side or end-play in gear shafts.

Seal Replacement

Recommended sealant for gearbox repair is Permatex® Aviation 3D Form-A-Gasket or equivalent.

Leakage can occur at the vertical or horizontal gaskets and shaft seals.

Leakage at the horizontal gasket or seal can be repaired without removing the gearbox from the cutter.

Seal Installation

NOTE: Proper seal installation is important. An improperly installed seal will leak.

1. Clean area in housing where seal outer diameter (OD) seats. Apply a thin coat of Permatex.
2. Inspect area of shaft where seal seats. Remove any burrs or nicks with an emery cloth.
3. Lubricate gear shaft and seal lips.
4. Place seal squarely on housing, spring-loaded lip toward housing. Select a piece of pipe or tubing with an OD that will sit on the outside edge of the seal but will clear the housing. Tubing with an OD that is too small will bow seal cage and ruin seal.
5. Carefully press seal into housing, avoiding distortion to the metal seal cage.

1. Seal
2. Pipe or tube
3. Seal seat
4. Casting

Pipe or tube must press at outer edge of seal.

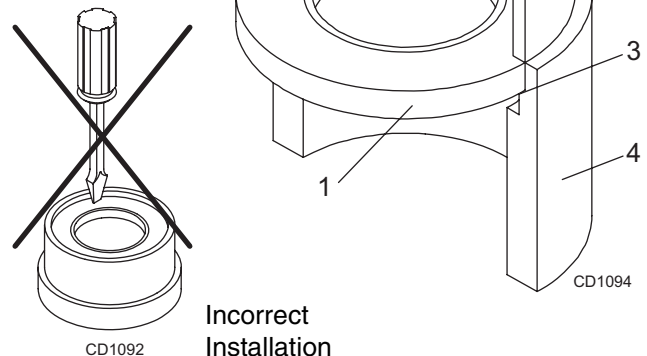

Figure 10. Seal Installation

Vertical Shaft Repair

**(BB48, BB60, BB72, all Serial Numbers)
(BB84 - S/N 827627 and after)**

Refer to Figure 11.

1. Disconnect and remove the rear driveline from the gearbox.
2. Remove vent plug (27) and siphon gear lube from housing through this opening.
3. Remove crossbar (see **Remove Crossbar, page 24**).

4. Remove vertical shaft seal (21). Replace with new seal (see **Seal Installation, page 18**).

Vertical seal should be recessed in housing. Horizontal seal should be pressed flush with outside of housing.

NOTE: Distortion to seal cage or damage to seal lip will cause seal to leak.

5. Fill gearbox with SAE 80W or 90W gear lube until it runs out the level plug.
6. Remove and replace any seal damaged in installation.

Horizontal Leak Repair

**(BB48, BB60, BB72, all Serial Numbers)
(BB84 - S/N 827627 and after)**

Refer to Figure 11.

1. Disconnect and remove the rear driveline from the gearbox.
2. Remove vent plug (27) and siphon gear lube from housing through this opening.
3. If the leak occurred at either end of horizontal shaft, remove oil cap (23) and/or oil seal (22). Replace with new one (refer to **Seal Installation, page 18**).
4. Fill gearbox with SAE 80W or 90W gear lube until it runs out the level plug.

GEARBOX REPAIR

**(BB48, BB60, BB72, all Serial Numbers)
(BB84 - S/N 827627 and after)**

NOTE: Repair to this gearbox is limited to replacing bearings, seals, and gaskets. Replacing gears, shafts, and a housing is not cost effective. Purchasing a complete gearbox is more economical.

Remove Gearbox from Cutter

Refer to Figure 11.

1. Disconnect and remove the rear driveline from the gearbox.
2. Remove vent plug (27) and siphon gear lube from housing through this opening.
3. Remove cotter pin, washer, and nut from vertical shaft and remove crossbar (see **Remove Crossbar, page 24**).

4. Remove the four bolts that attach gearbox to cutter and remove gearbox.

Disassemble Gearbox

Refer to Figure 11.

1. Remove 3/8" plug from side of gearbox and pour out gear oil.
2. Remove oil cap (23) (to be replaced).
3. Remove snap ring (12) and shim (15) from input shaft (3).
4. Support gearbox in hand press and push on input shaft (3) to remove bearing (9) and spacer (14).
5. Remove top cover (25) from housing. Remove gear (1) from inside housing.
6. Remove oil seal (22) from front of housing (to be replaced).
7. Remove snap ring (12) and shim (15) from front of housing (2).
8. Remove input bearing (8) by using a punch and hammer from outside of housing.
9. Support housing in vise in a horizontal position.
10. The castle nut (17), cotter pin (28), washer (18), and hub (24) are already removed with the stump jumper/crossbar. Remove the snap ring (10), washer (19), and seal (21).
11. Remove cotter pin (11), castle nut (16), and washer (20) from output shaft (4).
12. Remove output shaft (4) by using a punch and hammer and tap on top to drive down.
13. Remove gear (5) and shim (15) from inside housing.
14. Remove bearing (7) by using a punch and hammer from the top, outside the housing.
15. Support housing upside down (top cover surface) and remove bearing (6) by using a punch and hammer from the bottom side of the housing.
16. Inspect gears for broken teeth and wear. Some wear is normal and will show on loaded side. Forged gear surfaces are rough when new. Check that wear pattern is smooth.
17. Inspect vertical and horizontal shafts for grooves, nicks, or bumps in the areas where the seals seat. Resurface any damage with emery cloth.
18. Inspect housing and caps for cracks or other damage.

Reassemble Gearbox

Refer to Figure 11.

1. Clean housing, paying specific attention to areas where gaskets will be installed.
2. Wash housing and all components thoroughly. Select a clean area for gearbox assembly. Replace all seals, bearings, and gaskets. All parts must be clean and lightly oiled before reassembling.
3. Insert output bearings (6 & 7) in the housing, using a round tube of the correct diameter and a hand press.
4. Slide output shaft (4) through both bearings (6 & 7) until it rests against bearing (6).
5. Slide shim (15) over output shaft (4).
6. Press gear (5) onto output shaft (4) and secure with washer (20), castle nut (16), and cotter pin (11).
7. Apply grease to lower seal lips (21) and press seal (21) over output shaft (4), using a tube of the correct diameter. Be sure not to damage the seal lip.

Press in housing so that seal is recessed. Insert protective washer (19) by hand. Install snap ring (10) and position it together with dual lip seal (21) by pressing it into position. Verify that snap ring is seated correctly.
8. Press bearing (8) into the housing, using a round tube of the correct diameter and a hand press. Secure with shim (15) and snap ring (12).
9. Secure snap ring (13) on input shaft (3) if not already secure.
10. Place gear (1) through top of housing and align gear (1) and gear (5) so that gear teeth are a match.
11. While holding gear (1) in place, slide input shaft (3) through gear (1) and bearing (8). Align splines on shaft (3) and gear (1).

12. Slide spacer (14) over input shaft (3) and press bearing onto input shaft (3), using a round tube of the correct diameter and a hand press.
13. Slide shim (15) over input shaft (3) and secure with snap ring (12).
14. Check input shaft end float by moving the input shaft (3) by hand. If end float is higher than 0.012", insert shim between input shaft (3) and rear bearing (8). Repeat until end float is less than 0.012". Check rotational torque by hand. The torque should be less than 2.2 lbs-inch.
15. Check that the gear backlash is between 0.006" and 0.016". You should not have to adjust the backlash.
16. Press in input oil seal (22), using tube of correct diameter. Be careful not to damage seal lip.
17. Press oil cap (23) on to cover the rear of housing, using a tube of the correct diameter.
18. Check gearbox housing for leaks by plugging all holes except one. Apply 4 psi compressed air and immerse the gearbox in water to verify that there are no leaks.
19. Remove gearbox from water and dry off with compressed air. Add SAE 80W or 90W EP oil until it runs out of side level hole. Tighten all plugs.

Reinstall Gearbox

NOTE: Gearbox is heavy: do not attempt to move without mechanical assistance.

1. Set gearbox on cutter and fasten with bolts and nuts. Torque bolts as follows:

BB48, BB60, BB72	175 lbs-ft
BB84	300 lbs-ft
2. Attach crossbar (see **Remove Crossbar on page 24**).

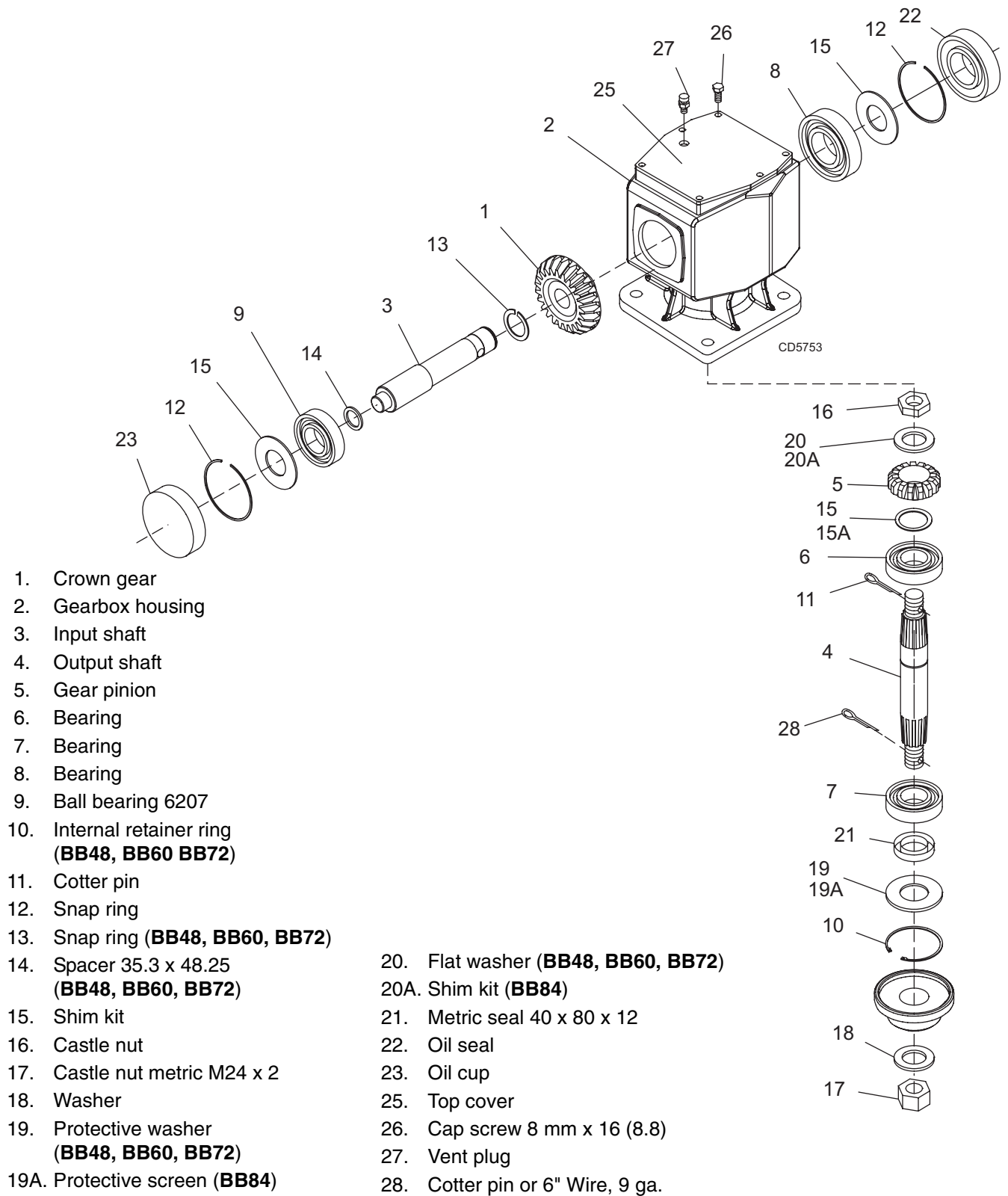

Figure 11. Gearbox Assembly
(BB48, BB60, BB72 All Serial Numbers)
(BB84–S/N 827627 & After)

GEARBOX REPAIR

(BB84 S/N 827626 & Prior)

Disassemble Gearbox

Refer to Figure 12.

1. Drain oil from gearbox.
2. Remove cover bolts (21) and lock washers (23).
3. Remove front cover plate (16). Remove bearing (13), gasket (15), and seal (14) from cover plate.
4. Remove shaft (11) along with gear (12) and bearing (10).
5. Remove lower cover bolts (22) and lock washers (17) from lower cover plate (1). Remove gasket (2) and seal (3) from bottom cover plate.
6. Remove output shaft along with bearings, gears, and castle nut from gearbox housing.
7. Remove cotter pin (18) and castle nut (24). Remove gear (8). Remove upper bearing cone (5), spacer (6), and lower bearing (5).
8. Remove bearing cone (5) and shims (7) from gear (8).

Reassemble Gearbox

Refer to Figure 12.

NOTE: Replace all seals, bearings, and gaskets. All parts must be clean and lubricated before assembling.

1. Insert bearing (10) into gearbox.
2. Reassemble output shaft (4) with bearings (5), spacer (6), gear (8), shims (7), and castle nut (24).

Insert output shaft with bearings into gearbox housing.

3. Tighten castle nut until shaft rolling torque is 5.5 to 13 lbs-inch. Insert cotter pin (18) through nut and shaft.
4. Insert seal (3) into lower cover (1). Place gasket (2) on cover (1), being careful to prevent cutting seal lip. Install lower cover output shaft. Install lock washers (17) and bolts (22). Shaft should not have any axial play.
5. Install gear (12) onto shaft (11). Install shim (26) on rear of shaft (11). Insert shaft (11) into gearbox housing.
6. Install seal (14) and bearing (13) in front of cover (16). Place shims (25) on shaft (11). Install gasket (15) on front cover (16). Install front cover over input shaft (11). Taking care not to damage seal, insert bolts (21) and lock washers (23).
7. Check end of shaft (11). Maximum play allowed is .008". Do not preload ball bearings (10 & 13). Gear backlash should be .006" to .017" at outer tooth.

Reinstall Gearbox

NOTE: Gearbox is heavy: do not attempt to move without assistance.

1. Set gearbox on cutter and fasten gearbox to cutter, using bolts and nuts. Torque hardware to 300 lbs-ft.
2. Attach crossbar (**see Install Crossbar on page 25**).
3. Fill housing to shaft center line with gear lube.

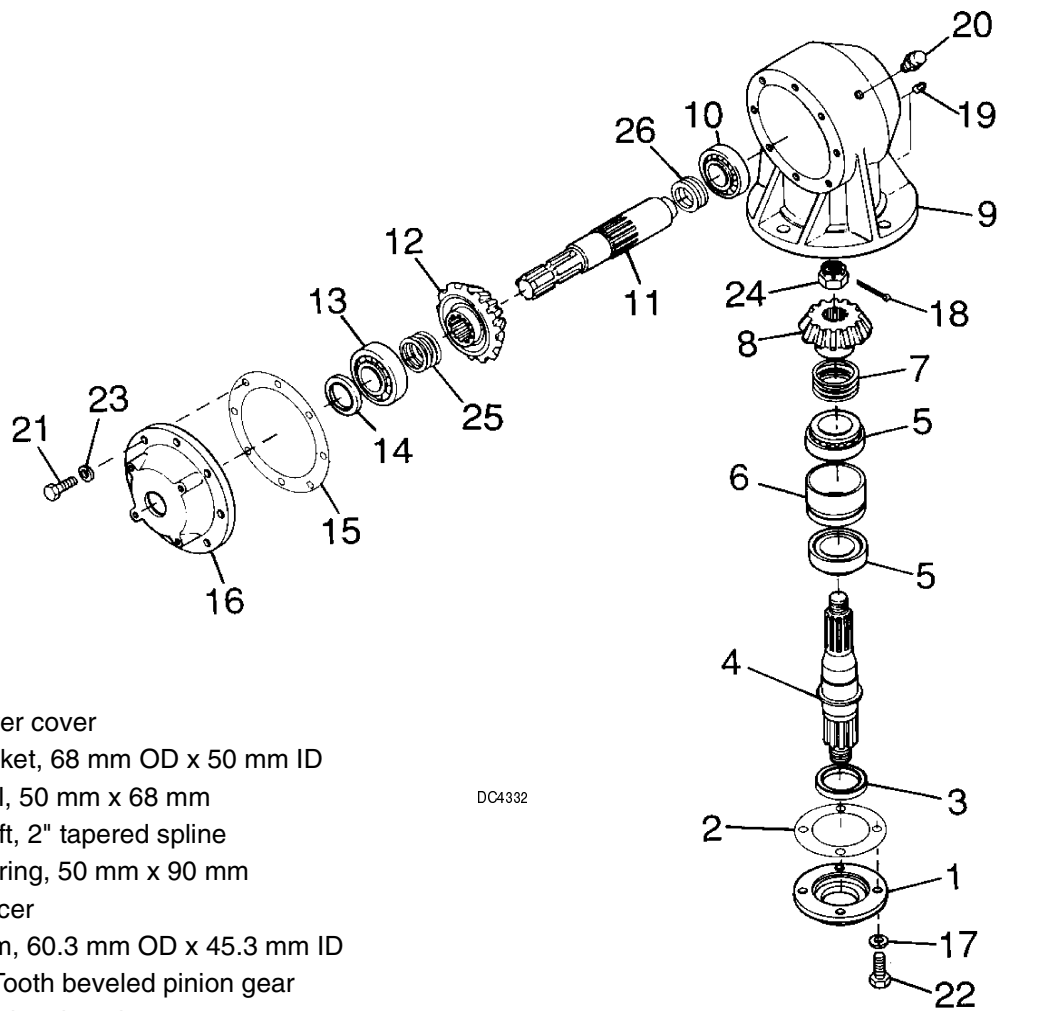

- | | | |
|-----|-------------------------------|--|
| 1. | Lower cover | |
| 2. | Gasket, 68 mm OD x 50 mm ID | |
| 3. | Seal, 50 mm x 68 mm | |
| 4. | Shaft, 2" tapered spline | |
| 5. | Bearing, 50 mm x 90 mm | |
| 6. | Spacer | |
| 7. | Shim, 60.3 mm OD x 45.3 mm ID | |
| 8. | 15-Tooth beveled pinion gear | |
| 9. | Gearbox housing | |
| 10. | Bearing, 35 mm x 80 mm | |
| 11. | Splined gear shaft | |
| 12. | 19-Tooth beveled gear | |
| 13. | Bearing, 40 mm x 90 mm | |
| 14. | Seal, 56 mm OD x 40 mm ID | |
| 15. | Gasket | |
| 16. | Front cover | |
| 17. | Lock washer, 10 mm | |
| 18. | Cotter pin, 5/32 x 1" | |
| 19. | 3/8 NPT Pipe plug | |
| 20. | Vent plug, 3/8 NPT | |
| 21. | Bolt, 8 mm x 20 mm | |
| 22. | Bolt, 10 mm x 25 mm | |
| 23. | Lock washer 5/16 | |
| 24. | Hex castle nut | |
| 25. | Shim, 51.5 mm OD x 40.3 mm ID | |
| 26. | Shim, 43 mm OD x 35.3 mm ID | |

Figure 12. Gearbox Assembly (BB84 S/N 827626 & Prior)

REMOVE CROSSBAR

1. It is necessary to gain access to bottom side of cutter for crossbar removal. See **Blocking Method**, page 12.

NOTE: You will need to use either the puller screw (Item 6, Figure 14) or a small hydraulic jack to remove the crossbar.

2. To make crossbar removal easier, remove blades as shown in Figure 13.

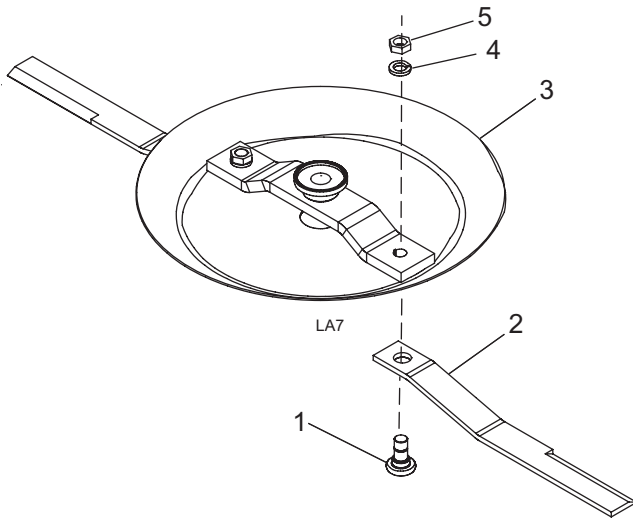

Figure 13. Blade Removal (BB84 Shown)

3. Refer to Figure 14. Remove retaining wire from bottom of crossbar and remove nut and washer.
4. Attach a clevis (1) to each end of crossbar, using blade pins, spacers, keyhole plates, and blade pin clips.
5. Position tube assembly (5) with threaded nut toward crossbar for puller screw removal or down for hydraulic jack removal.
6. For removal with puller screw, attach tube (5) to each clevis with bolts (2) and nuts (3). Place pad (4) in nut and thread puller screw (6) into nut from bottom. Tighten until pad is solid against gearbox shaft. For best results, strike head of puller screw with a hammer while tightening with a wrench.
7. For removal with a jack, attach tube to each clevis with puller links (7), bolts (2), and nuts (3). Place jack on tube with end of jack pressing against gearbox shaft. Slowly apply force with jack.

NOTE: Hydraulic jack will not operate if tipped more than 90-degrees. Use care to prevent bending crossbar during removal.

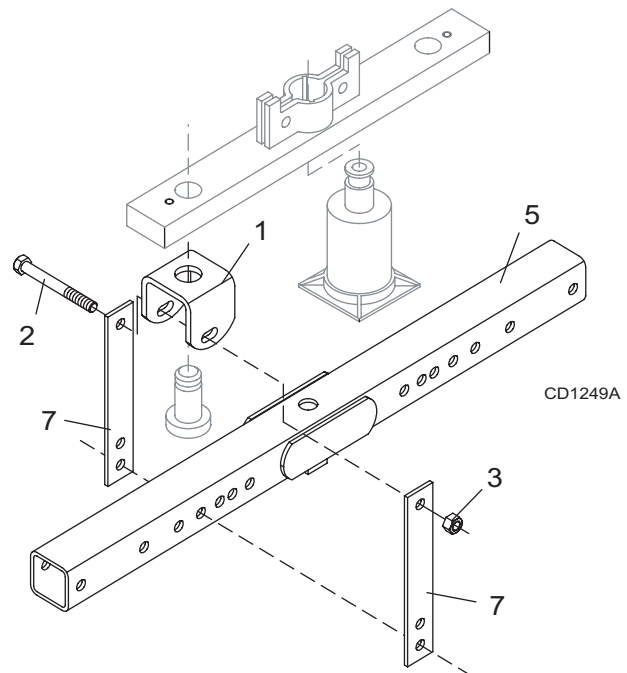
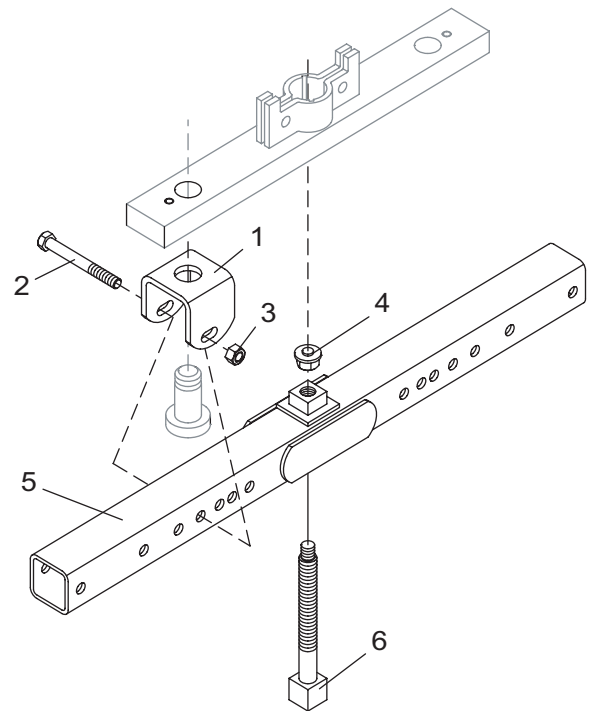

Figure 14. Crossbar Removal

INSTALL CROSSBAR

1. Using emery cloth (220 or finer), remove surface rust, Loctite and foreign material from hub, splined gearbox, vertical shaft, and crossbar as shown in Figure 15.

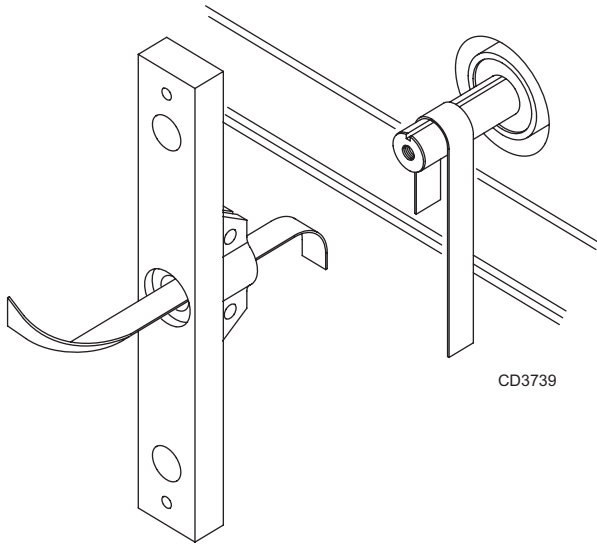

Figure 15.

2. Install crossbar (2) on splined shaft. Install washer (3) and nut (4). Torque nut:

BB48, BB60, BB72	200 lbs-ft
BB84	300 lbs-ft

3. Install 6" section of 9 gauge wire (not supplied) through gearbox shaft and slots in nuts. Twist ends of wire together.
4. Install blades, reinstall them using existing hardware. Torque blade pin nut to 450 lbs-ft.

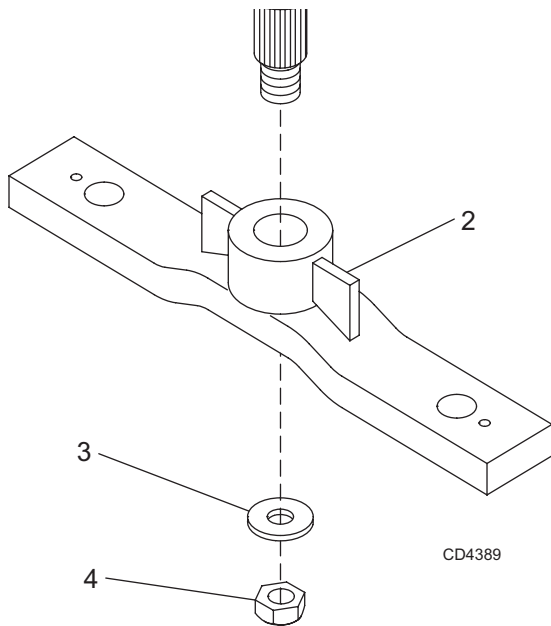

Figure 16

UNIVERSAL JOINT REPAIR

1. Yoke
2. Cup and bearing
3. Snap ring
4. Journal cross

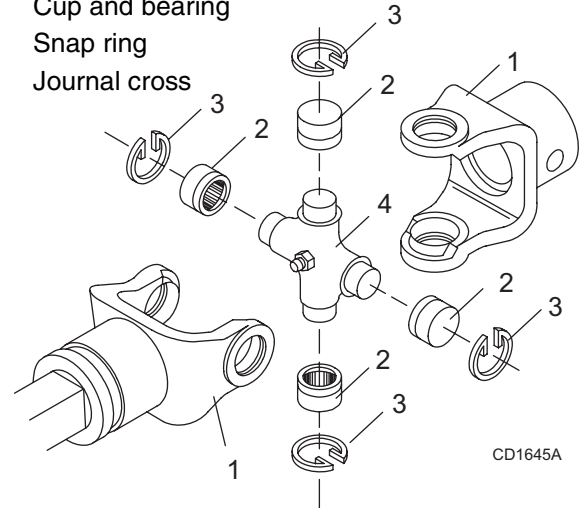

Figure 17. Universal Joint Parts Breakdown

U-Joint Disassembly

1. Remove external snap rings from yokes in four locations as shown in Figure 18.

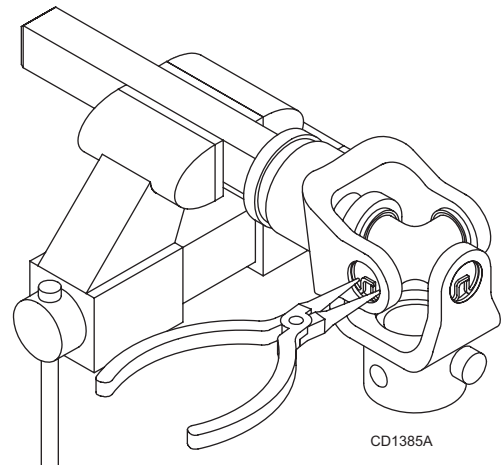

Figure 18. Remove Snap Ring

2. With snap rings removed, support drive in vise, hold yoke in hand and tap on yoke to drive cup up out of yoke. See Figure 19.

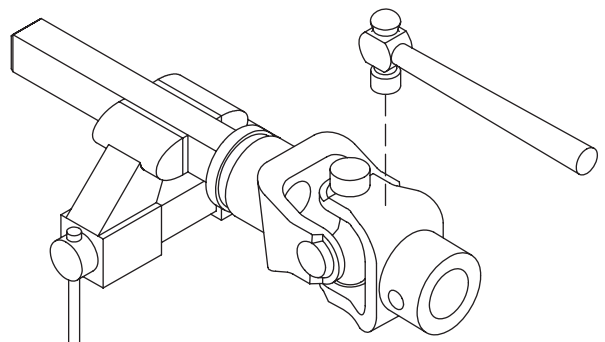

Figure 19. Remove Cups

3. Clamp cup in vise as shown in Figure 20 and tap on yoke to completely remove cup from yoke. Repeat Step 2 and Step 3 for opposite cup.

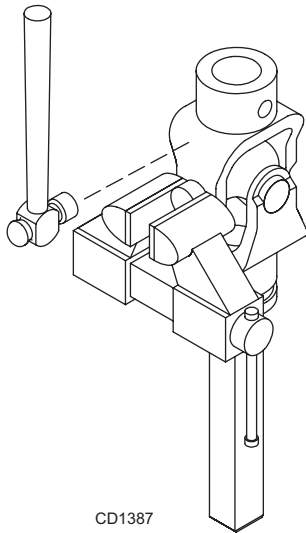

Figure 20. Remove Cups

4. Place universal cross in vise as shown in Figure 21 and tap on yoke to remove cup. Repeat Step 3 for final removal. Drive remaining cup out with a drift and hammer.

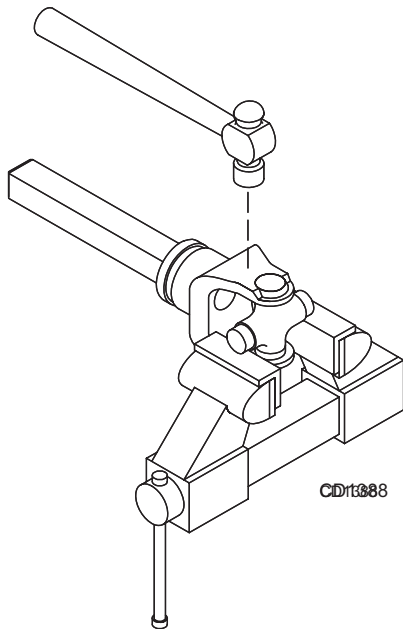

Figure 21. Remove Cups

U-Joint Assembly

1. Place seals securely on bearing cups. Insert cup into yoke from outside and press in with hand pressure as far as possible. Insert journal cross into bearing cup with grease fitting away from shaft. Be careful not to disturb needle bearings. Insert another bearing cup directly across from first cup and press in as far as possible with hand pressure. Trap cups in vise and apply pressure. Be sure journal cross is started into bearings and continue pressure with vise, squeezing in as far as possible. Tapping the yoke will help.
2. Seat cups by placing a drift or socket (slightly smaller than the cup) on cup and rap with a hammer. See Figure 22. Install snap ring and repeat on opposite cup
3. Repeat Step 1 and Step 2 to install remaining cups in remaining yoke.
4. Move both yokes in all directions to check for free movement. If movement is restricted, rap on yokes sharply with a hammer to relieve any tension. Repeat until both yokes move in all directions without restriction.

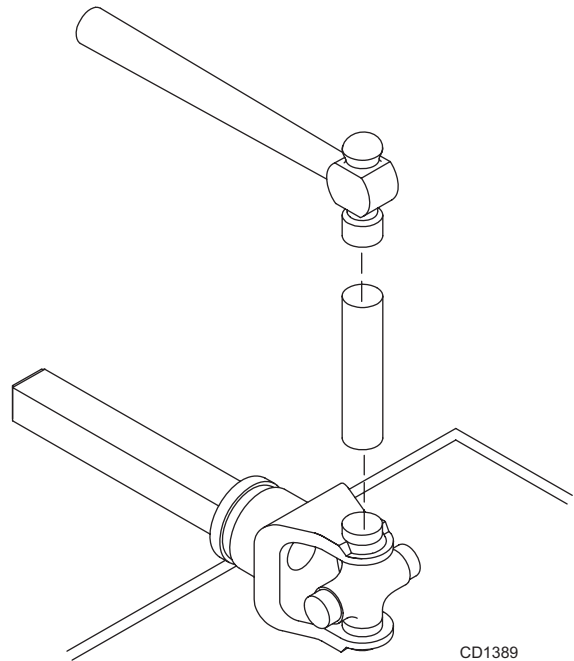

Figure 22. Install Cups

DEALER CHECK LISTS

PRE-DELIVERY CHECK LIST (DEALER'S RESPONSIBILITY)

IMPORTANT

■ **Gearbox was not filled at the factory. It must be serviced before operating cutter. (See Fill Gearbox, page 32). Failure to service will result in damage to gearbox.**

Inspect cutter thoroughly after assembly to make sure it is set up properly before delivering it to the customer. The following check list is a reminder of points to inspect. Check off each item as it is found satisfactory, corrections are made, or services are performed.

- ___ Check all bolts to be sure they are properly torqued.
- ___ Check that all cotter pins are properly installed and secured.
- ___ Check that PTO shaft is properly installed.
- ___ Check that gearbox is properly serviced and seals are not leaking.
- ___ Check and grease all lubrication points as identified in, **Lubrication Information, page 13.**
- ___ Check that blades have been properly installed.

DELIVERY CHECK (DEALER'S RESPONSIBILITY)

- ___ Show customer how to make adjustments. Describe the options available for this cutter and explain their purpose.
- ___ Explain importance of lubrication to customer and point out lubrication points on cutter.
- ___ Present Operator's Manual and request that customer and all operators read it before operating equipment. Point out the manual safety rules, explain their meanings and emphasize the increased safety hazards that exist when safety rules are not followed.
- ___ Point out all guards and shielding. Explain their importance and the safety hazards that exist when not kept in place and in good condition. For mounted units, add wheel weights, ballast in front tires, and/or front tractor weight to enhance front end stability. A minimum 20% of tractor and equipment gross weight must be on front tractor wheels. When adding weight to attain 20% of tractor and equipment weight on front tractor wheels, you must not exceed the ROPS weight certification. Weigh the tractor and equipment. Do not estimate!
- ___ Explain to customer that when equipment is transported on a road or highway, safety devices should be used to give adequate warning to operators of other vehicles.

ASSEMBLY

DEALER SET-UP INSTRUCTIONS

Assembly of this cutter is the responsibility of the Woods dealer. It should be delivered to the owner completely assembled, lubricated, and adjusted for normal cutting conditions.

The cutter is shipped partially assembled. Assembly will be easier if aligned and loosely assembled before tightening hardware. Recommended torque values for hardware are located in the **Bolt Torque Chart, page 46**.

Complete **Dealer Check Lists, page 27** when you have completed the assembly.

⚠ DANGER

■ Full chain, rubber, or steel band shielding, designed to reduce the possibility of thrown objects, must be installed when operating in populated areas or other areas where thrown objects could injure people or damage property. If this

machine is not equipped with full chain, rubber, or steel band shielding, operation must be stopped when anyone comes within several hundred feet.

⚠ WARNING

- Make sure spring-activated locking pin or collar slides freely and is seated firmly in tractor PTO spline groove.
- Operate tractor PTO at the rpm speed stated in "Specifications" section.

⚠ CAUTION

- Always wear relatively tight and belted clothing to avoid getting caught in moving parts. Wear sturdy, rough-soled work shoes and protective equipment for eyes, hair, hands, hearing, and head; and respirator or filter mask where appropriate.

1. Mounting pin hardware
2. A-frame bar
3. Upper mounting hardware (under clutch shield)
4. Diagonal brace
- 5A. Diagonal brace bar mounting hole
- 5B. Tailwheel pivot hole
6. Tailwheel bracket
7. PTO Hanger
9. Tailwheel
10. Height adjustment
12. Bag of hardware
13. Driveline (Shear bolt)
14. Clutch shield

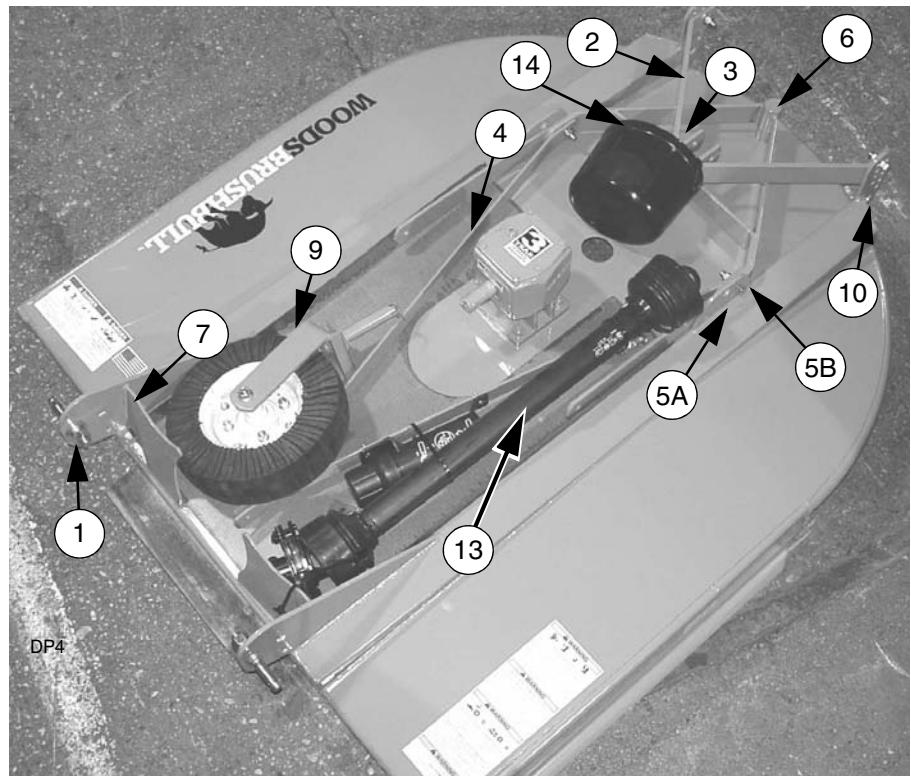

Figure 23. BB48 & BB60 Shipping Configuration

1. Mounting pin hardware
2. A-frame bar
3. Upper mounting hardware
4. Diagonal brace
- 5A. Diagonal brace bar mounting hole
- 5B. Tailwheel pivot hole
6. Tailwheel bracket
7. PTO Hanger
9. Tailwheel
10. Height adjustment
12. Bag of hardware
13. Driveline (Slip clutch)
14. Clutch shield

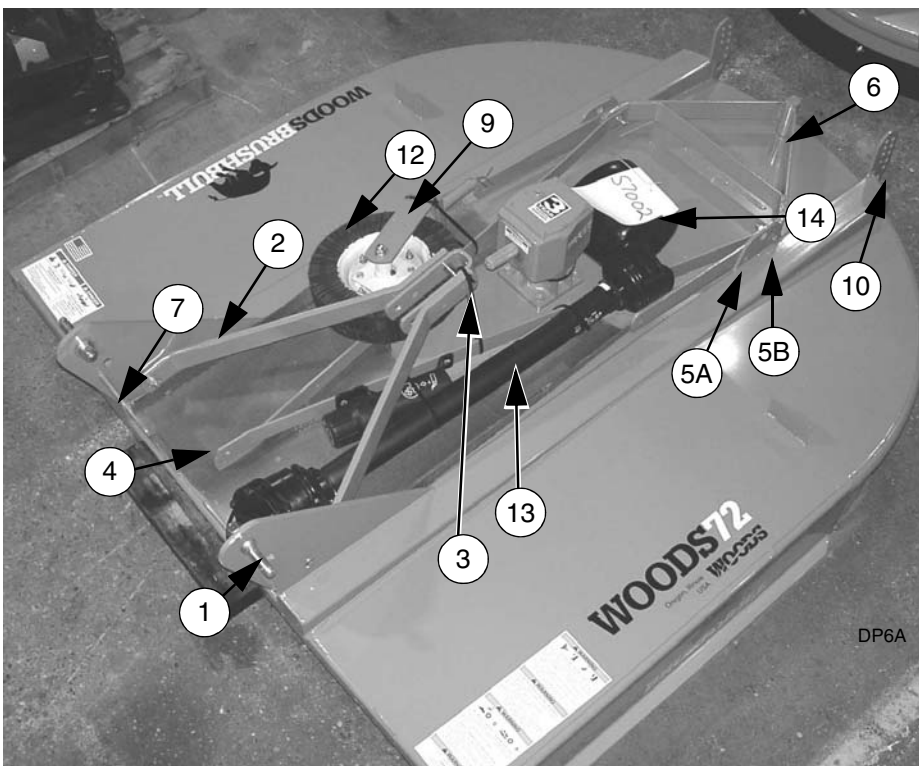
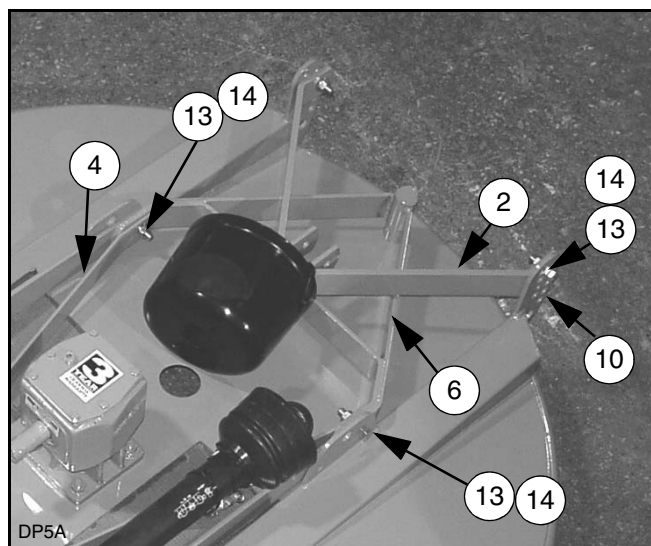

Figure 24. BB72 & BB84 Shipping Configuration

ASSEMBLE CUTTER

Disassemble Shipping Unit

1. Remove all parts that are wired and strapped to cutter.
2. Remove cap screws (13) and flange lock nuts (14) that are securing A-frame bars (2) to the cutting height adjustment holes (10).
3. Remove cap screws (13) and flange lock nuts (14) that are securing tailwheel bracket (6) and diagonal brace bars (4) to cutter. See Figure 25.



2. A-frame bar
4. Diagonal brace bar
6. Tailwheel bracket
10. Height adjustment
13. 5/8 NC x 2 Cap screw
14. 5/8 NC Flange lock nut

Figure 25. BB60 Shown

Install Tailwheel

1. Attach tailwheel bracket (6) to cutter at the tailwheel pivot holes (5B) using cap screw (13) and flange lock nut (14) previously removed.

NOTE: Make sure grease fitting on tube is on top when installing tailwheel.

2. Select desired height adjustment holes (10), and secure tailwheel bracket with cap screws (13) and flange lock nuts (14). Cutting height adjustment will be necessary when cutter is fully assembled. See page 9.
3. Raise rear of cutter and insert tailwheel assembly (9) into tailwheel bracket (6). Secure with washer (37) and spiral pin (28).
4. Place diagonal brace bars (4) on the inside of frame rails and attach to diagonal brace mounting holes (5A). Secure using cap screws (13) and flange lock nuts (14).

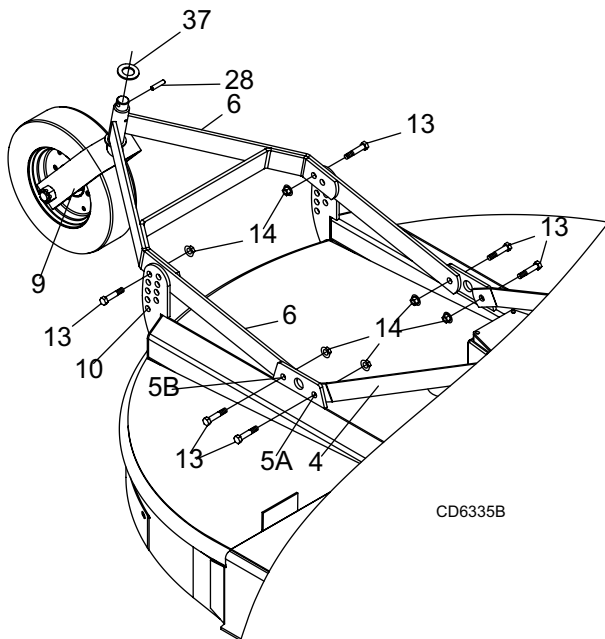

4. Diagonal brace bar
- 5A. Diagonal brace mounting hole
- 5B. Tailwheel pivot hole
6. Tailwheel bracket
9. Tailwheel assembly
10. Cutting height bracket
13. 5/8 NC x 2 Cap screw
14. 5/8 NC Flange lock nut
28. Spirol pin
37. 33 mm Flat washer

Figure 26. Tail Wheel Installation

Install A-Frame

BB48 & BB60 Cutters: Attach A-frame bars (2) to the inside of front mast plates. Secure into position using carriage bolts (15), sleeves (16), flat washers (17), and flange lock nuts (14).

2. A-frame bar
14. 5/8 NC Flange lock nut
15. 5/8 NC x 2 Carriage bolt
16. 5/8 x 1-9/16 Sleeve
17. 5/8 Flat washer

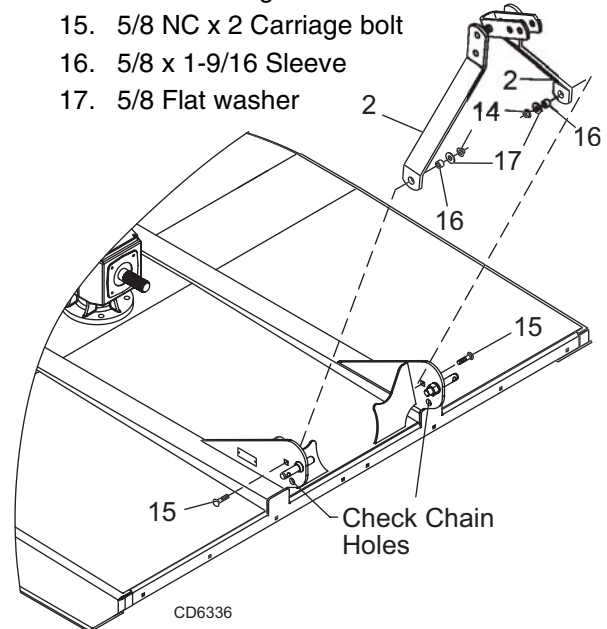

Figure 27. BB48 and BB60 Only Assembly

BB72 & BB84 Cutters: A-frame bars (2) are already attached to the front mast plates. Rotate up for connection to diagonal brace bars.

2. A-frame bar
14. 5/8 NC Flange lock nut
15. 5/8 NC x 2 Carriage bolt
16. 5/8 x 1-9/16 Sleeve
17. 5/8 Flat washer

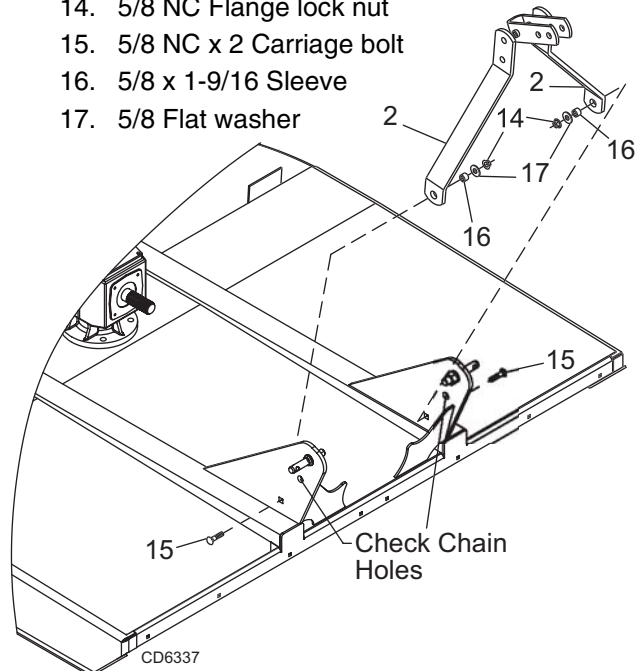
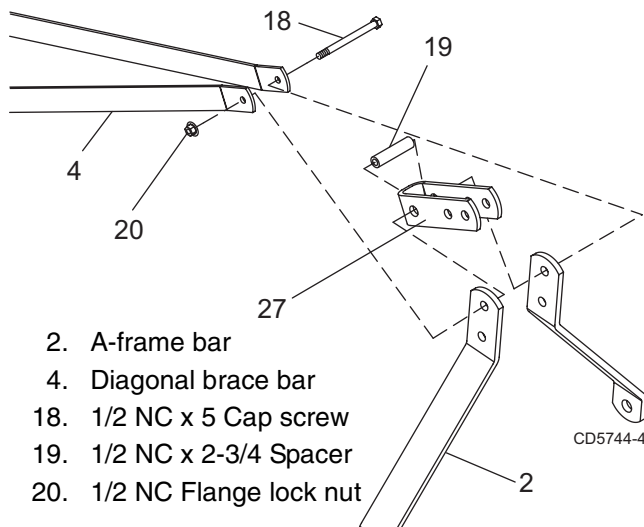

Figure 28. BB72 and BB84 Only Assembly

Install A-Frame to Diagonal Brace Bars

1. Remove cap screw (18) and flange lock nut (20) from top hole on A-frame bars. Leave spacer (19) and float link (27) together.
2. Position diagonal brace bars (4) on the outside of A-frame bars (3).
3. Align diagonal brace bars with top hole in A-frame bars, float link, and spacer. Secure with cap screw (18) and flange lock nut (20) that were previously removed.



- 2. A-frame bar
- 4. Diagonal brace bar
- 18. 1/2 NC x 5 Cap screw
- 19. 1/2 NC x 2-3/4 Spacer
- 20. 1/2 NC Flange lock nut

Figure 29. Diagonal Brace Bars to A-Frame Connection

Quick Hitch Set-Up

An optional Quick Hitch attachment may be used on this cutter. Install A-frame as shown below (Figure 30).

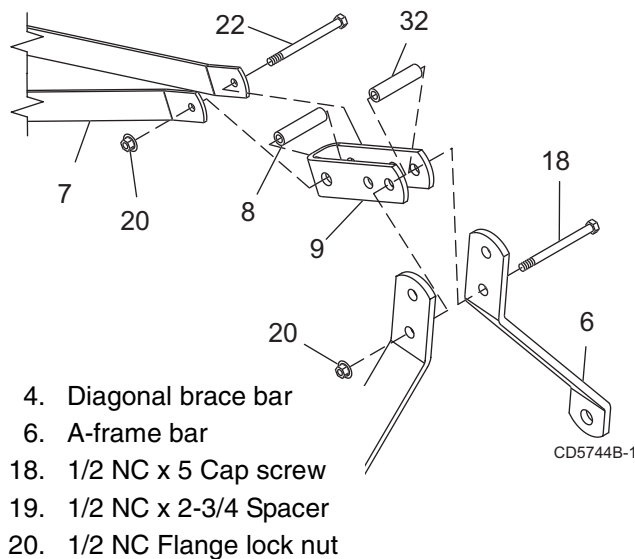

- 4. Diagonal brace bar
- 6. A-frame bar
- 18. 1/2 NC x 5 Cap screw
- 19. 1/2 NC x 2-3/4 Spacer
- 20. 1/2 NC Flange lock nut

Figure 30. Diagonal Brace Bars to A-Frame Connection for Quick Hitch

INSTALL DRIVELINE

Select either the standard shear bolt or optional slip clutch driveline.

Install Driveline Shear Bolt BB48 & BB60 Only

IMPORTANT

■ A grade 2 bolt must be used for the shear bolt to provide gearbox protection.

1. Remove rear drive shield (1) from driveline.
2. Position clutch shield (5) against gearbox. Secure using cap screw (7), lock washers (8), and flat washers (9). Torque hardware to 12 lbs-ft.
3. To prevent seal damage, carefully push driveline onto gearbox input shaft until it contacts the gearbox housing.
4. Place retaining ring (6) in slot on input shaft and snap into place.
5. Align the holes in the driveline yoke and gearbox input shaft. Install and tighten shear bolt (4) and nut (3).
6. Install rear drive shield to driveline.
7. Lubricate rear driveline half and install front driveline half.
8. Attach tether chain to diagonal brace bar.

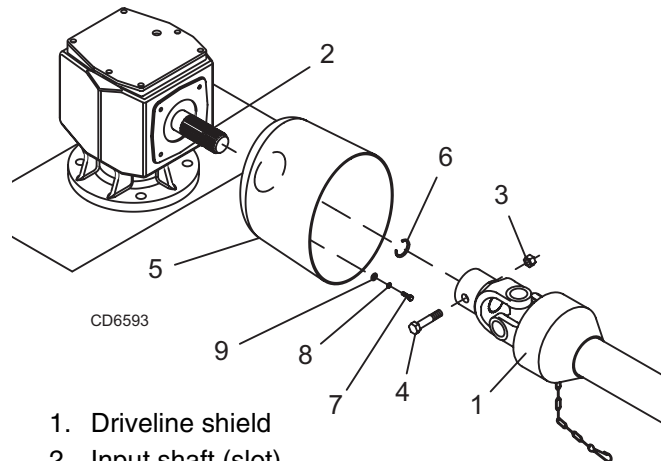

1. Driveline shield
2. Input shaft (slot)
3. 1/2 NC Lock nut
4. 1/2 NC x 3 Cap screw GR2 (Shear Bolt)
5. Clutch shield
6. Retaining ring
7. M8 x 1.25P x 20 mm Cap screw
8. 5/16 Lock washer
9. 5/16 Flat washer

Figure 31. Shear Bolt Driveline Assembly

Install Driveline Slip Clutch (Optional on BB48 and BB60)

IMPORTANT

■ A grade 8 bolt must be used to attach clutch driveline to gearbox.

A new slip clutch, or one that has been in storage over the winter, may seize.

1. Before operating slip clutch, make sure it will slip. Refer to **Adjust Slip Clutch, page 15**.
2. Position clutch shield (3) against gearbox. Secure using cap screw (4), lock washers (5), and flat washers (6). Torque hardware to 12 lbs-ft.
3. Install driveline onto gearbox input shaft and secure with bolt (1) and nut (2).
4. Secure driveline with bolt (1) and nut (2).
5. Lubricate rear driveline half and install front driveline half.
6. Attach tether chain to diagonal brace bar.

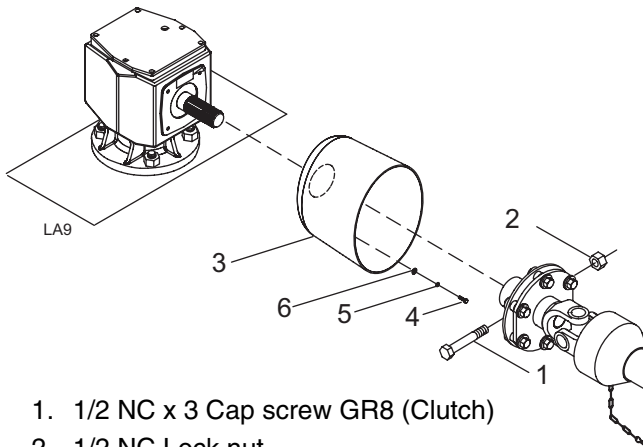

1. 1/2 NC x 3 Cap screw GR8 (Clutch)
2. 1/2 NC Lock nut
3. Clutch shield
4. M8 x 1.25P x 20 mm Cap screw
5. 5/16 Lock washer
6. 5/16 Flat washer

Figure 32. Optional Slip Clutch Driveline Assembly
BB48 and BB60

Install Driveline Slip Clutch (BB72 and BB84)

1. Before operating slip clutch, make sure it will slip. Refer to **Adjust Slip Clutch, page 15**.
2. Position clutch shield (3) against gearbox. Secure using cap screw (4), lock washers (5), and flat washers (6). Torque hardware to 12 lbs-ft.
3. Install driveline onto gearbox input shaft and secure with bolt (1) and nut (2).

4. Secure drive by releasing lock collar slide onto the gearbox shaft and release lock collar when balls are seated into groove. Pull on drive to insure drive is secure.

INSTALL SAFETY SHIELDING

Install Optional Chain Shielding

! DANGER

■ Full chain, rubber, or steel band shielding, designed to reduce the possibility of thrown objects, must be installed when operating in populated areas or other areas where thrown objects could injure people or damage property. If this machine is not equipped with full chain, rubber, or steel band shielding, operation must be stopped when anyone comes within several hundred feet.

The optional chain shielding assemblies are ready for installation when you receive them.

1. Refer to **Front & Rear Chain Shielding, page 48** and attach as shown by inserting the bolts from inside the cutter frame out through the shielding.
2. Install hardware as shown in the parts drawing.

Install Optional Rubber Deflector

Attach rubber deflector (45) and link (2) to front of cutter using carriage bolts (16) and flange lock nuts (17).

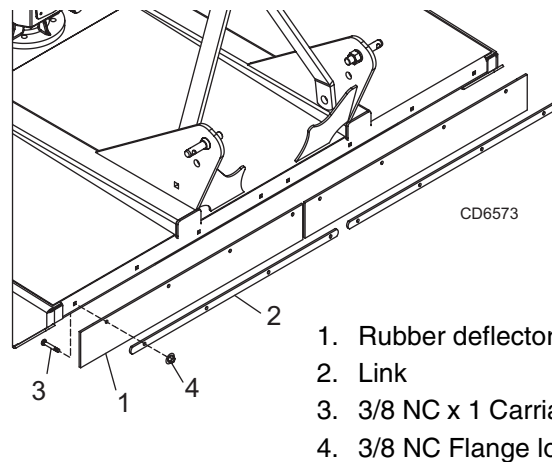

1. Rubber deflector
2. Link
3. 3/8 NC x 1 Carriage bolt
4. 3/8 NC Flange lock nut

Figure 33. Optional Rubber Deflector Installation

FILL GEARBOX

IMPORTANT

■ Gearbox is not filled at the factory. Prior to delivery to customer, make sure gearbox is filled only half-full with 80W or 90W API GL-4 or GL-5 gear lube. Use side plug to remove any excess oil.

1. Remove solid plug and discard.
2. Make sure vent plug hole is clear.
3. Fill gearbox until oil runs out the side plug on gearbox. Use a high quality gear oil with a viscosity index of 80W or 90W and an API service rating of GL-4 or GL-5.
4. Install vent plug. Use pipe sealant or thread tape on threads.

INSTALL OPTIONAL CHECK CHAINS

Check chains are used to carry the front of cutter at a set height.

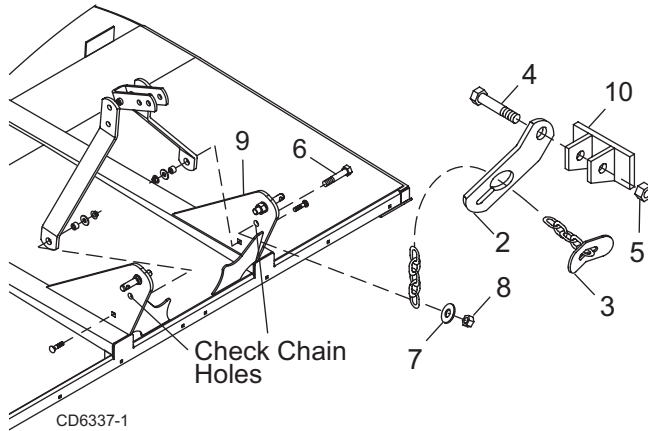

BB72 or BB84 Check Chain Installation

1. Check chain complete
2. Check chain bracket, lower
3. 3/8 Chain, 32-link and check lug
4. 3/4 NC x 6 Cap screw GR5
5. 3/4 NC Hex lock nut
6. 5/8 NC x 2-1/4 Cap screw GR5
7. 5/8 Flat washer, standard
8. 5/8 NC Hex nut
9. Mast Plate BB72 or BB84
10. Tractor top link bracket

1. Thread check chains (3) through check chain bracket (2).
2. Attach lower end of check chain (3) to mast plate (9 or 11) with bolt (6), washer (7), and nut (8).
3. Attach keyhole brackets (2) to each side of tractor top link bracket (10) with bolt (4) and nut (5).
4. Insert check chains through keyhole brackets and set cutter height.

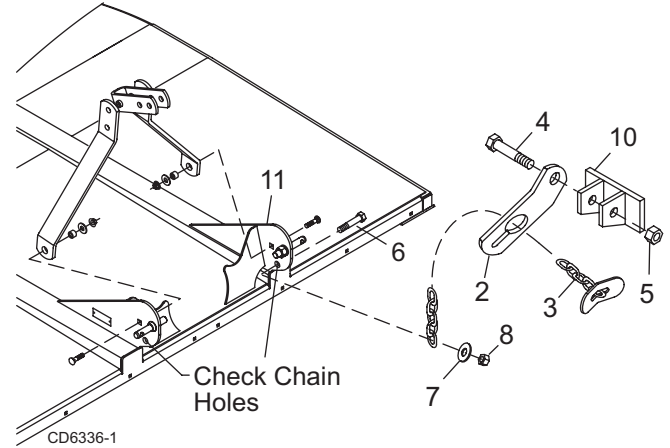

BB48 or BB60 Check Chain Installation

1. Check chain complete
2. Check chain bracket, lower
3. 3/8 Chain, 32-link and check lug
4. 3/4 NC x 6 Cap screw GR5
5. 3/4 NC Hex lock nut
6. 5/8 NC x 2-1/4 Cap screw GR5
7. 5/8 Flat washer, standard
8. 5/8 NC Hex nut
10. Tractor top link bracket
11. Mast Plate BB48 or BB60

Figure 34. Check Chain Installation

NOTE

BRUSHBULL™

Rotary Cutters:

BB48

BB60

BB72

BB84

BRUSHBULL™ STANDARD-DUTY ASSEMBLY	36-37
GEARBOX ASSEMBLY & PARTS LIST (BB48, BB60, BB72; BB84–S/N 827627 & AFTER)	38-39
CHECK CHAIN ASSEMBLY (OPTIONAL)	39
GEARBOX ASSEMBLY (BB84–S/N 827626 & PRIOR)	40
BB72 COMER SLIP CLUTCH DRIVELINE ASSEMBLY	41
BB72 & BB84 WALTERSCHIED SLIP CLUTCH DRIVELINE ASSEMBLY ...	42
BB48 COMER STANDARD DRIVELINE ASSEMBLY	43
BB60 COMER STANDARD DRIVELINE ASSEMBLY	44
BB48 & BB60 WALTERSCHIED STANDARD DRIVELINE ASSEMBLY	45
BB48 & BB60 COMER SLIP CLUTCH DRIVELINE ASSEMBLY (OPTIONAL)	46
BB48 & BB60 WALTERSCHIED SLIP CLUTCH DRIVELINE ASSEMBLY (OPTIONAL)	47
FRONT & REAR CHAIN SHIELDING	48
RUBBER SHIELDING (OPTIONAL)	49

BRUSHBULL STANDARD DUTY ASSEMBLY BB48, BB60, BB72 & BB84 (BB84 SHOWN)

Units with Serial Number 994126 & prior include tail wheel with fabricated steel hub. Units with Serial Number 994127 & after include tail wheel with cast iron hub. Item 14 (4 x 15 Notat Tire/Wheel) includes cast iron hub.

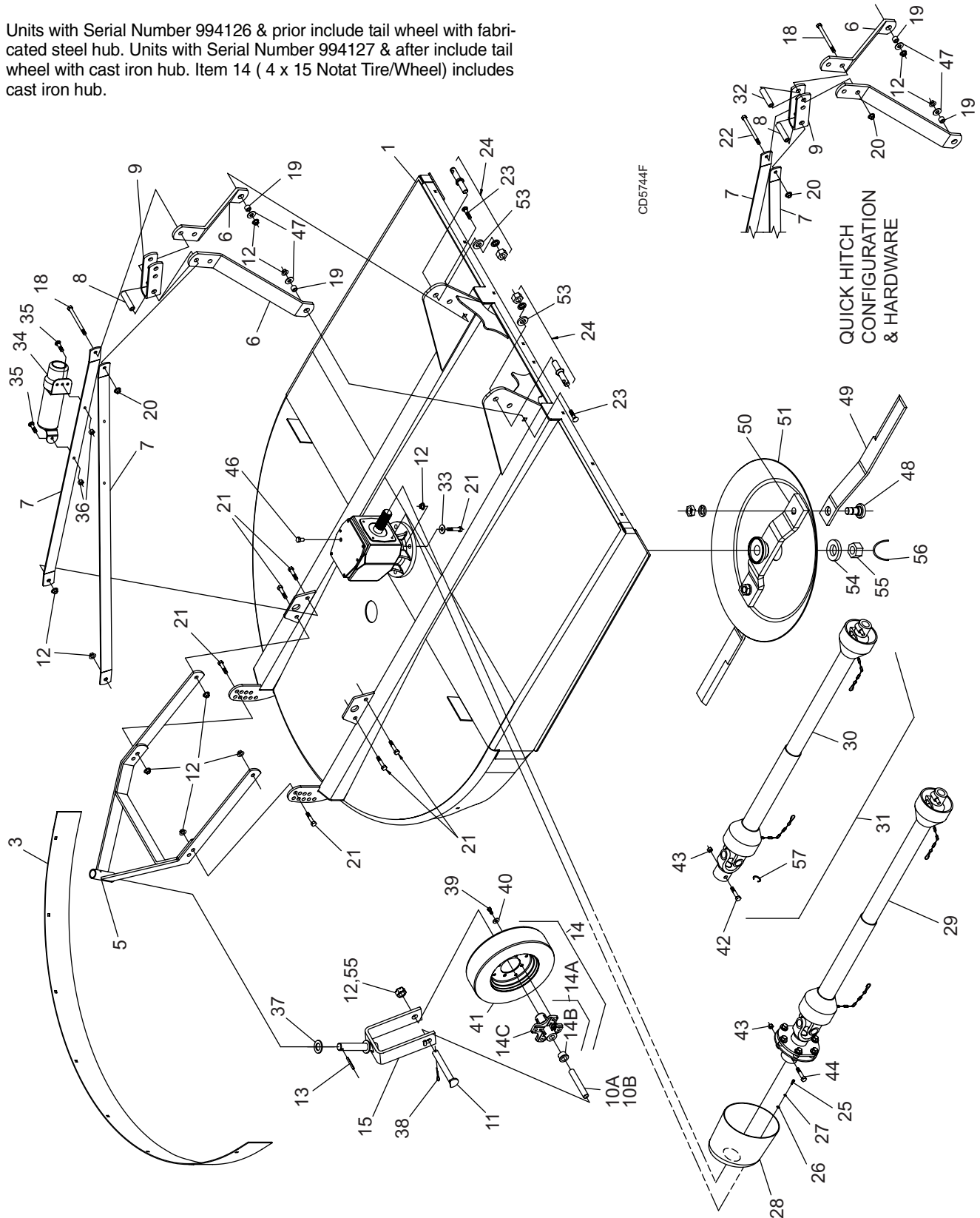

36 Parts

(Rev. 10/27/2006)
MAN0050 (Rev. 1/21/2005)

BB48, BB60, BB72 & BB84 PARTS LIST

REF	PART	QTY	DESCRIPTION	REF	PART	QTY	DESCRIPTION
3	57236	1	Rear band - BB48	30	57409	1	Complete drive asy - BB84
3	57210	1	Rear band - BB60	30	40554	1	Complete drive asy - BB48
3	57183	1	Rear band - BB72	30	40555	1	Complete drive asy - BB60
3	57184	1	Rear band - BB84	30	1009509	1	Complete drive asy - BB48
5	57162	1	Tailwheel assembly	30	1009510	1	Complete drive asy - BB60
6	57238	2	Link, offset - (A-frame bar) BB48 & 60	31	————	1	BB48 & BB60 Standard drive or BB48 & BB60 Slip clutch drive
6	57223	2	Link, offset - (A-frame bar) BB72 & 84	32	33657	1	1/2 x 3/4 x 2-13/16 Sleeve (used for quick hitch only)
7	57239	2	Link, offset - (Diagonal brace) BB48	33	57817	4	5/8 Flat washer, hardened (BB48, BB60, BB72)
7	57220	2	Link, offset - (Diagonal brace) BB60	33	57798	4	3/4 Flat washer, hardened BB84
7	57153	2	Link, offset - (Diagonal brace) BB72	34	1003828	1	Manual tube
7	57199	2	Link, offset - (Diagonal brace) BB84	35	24409	*2	5/16 NC x 1 Carriage bolt
8	64814	1	Spacer 1/2 x 2-3/4	36	4529	*2	5/16 NC Hex nut
9	15321	1	Link, bent .38 x 2.5 x 9.13	37	*	1	Washer, 33 mm x 56 mm x 4 mm (S/N 994127 & after)
10	57182	1	Sleeve, .656 x .997 x 5.39	38	*	1	Cotter pin (S/N 994127 & after)
10B	1013219	1	Sleeve, .656 x .985 x 5.24 (S/N 994126 & prior / cast iron hub)	39	23029	4	M12-1.75P x 25 Cap screw (S/N 994127 & after)
11	23638	1	5/8 NC x 7 Cap screw GR5	40	*	4	M12 Flat washer (S/N 994127 & after)
11	1013878	1	M24 x 2 x 192 Spindle bolt (S/N 994127 & after)	41	4676	1	4 x 15 Notat tire & rim (S/N 994127 & after)
12	19025	13	5/8 NC Flange lock nut	42	15349	1	1/2 NC x 3 Shear bolt GR2
13	13853	1	Spirol pin 3/8 x 1-3/4	43	765	*2	1/2 NC Lock nut - BB48 & BB60
13	40775	1	Spirol pin 10 mm x 65 mm (S/N 994127 & after)	44	1024632	1	1/2 NC x 3 Cap screw GR8 - Clutch
14	15373	1	4 x 16 Solid core tire - BB48	46	57076	1	Vent plug, (See page 38)
14	1013222	1	4 x 15 Notat tire / wheel (S/N 994126 & prior)(includes 10B)	47	692	*2	5/8 Flat washer
14A	1009091	1	Wheel hub assembly (Notat tire only)	48	15331	2	Blade pin - BB48 & BB60 (includes washer & nut)
14B	1009090	2	Bushing Flange 1.00 x 1.37 x 1.00 (Notat tire only)	48	57093	2	Blade pin - BB72 & BB84 (includes washer & nut)
14B	1013880	2	Bushing, flanged .984 x 1.378 x .98 (For cast iron hub only)	49	30310KT	1	Blade 3/8 x 3 x 16 CCW - BB48
14C	1013879	1	Cast iron wheel hub (S/N 994127 & after)	49	15326KT	1	Blade 3/8 x 3 x 20.50 CCW - BB60
15	15314	1	Tail wheel clevis	49	57189KT	1	Blade 1/2 x 3 x 26.5 CCW BB72 & BB84
15	1013220	1	Tail wheel clevis (S/N 994127 & after)	50	1013200	1	Crossbar and hub - BB48, BB60, BB72
16	6697	*8	3/8 NC x 1 Carriage bolt GR5	50	57190	1	Crossbar asy (BB84 - S/N 827626 & prior)
17	14350	8	3/8 NC Flange lock nut	50	1004127	1	Crossbar asy (BB84 -S/N 827627 & after)
18	23479	*1	1/2 NC x 5 Cap screw GR5	51	15330	1	Stump jumber - (BB48, BB60, BB72)
19	1791	2	Sleeve 5/8 x 1 x 9/16 HT	53	1001521	2	Washer, .880 x 1.88 x .50
20	11900	2	1/2 Flange lock nut	54	20893	1	Washer, 25 x 44 x 4 mm (BB48, BB60, BB72)
21	902	*10	5/8 x 2 Cap screw GR5	54	39322	1	Washer, 31 x 56 x 4 mm BB84
22	10380	*1	1/2 NC x 4 Cap screw GR5 (used for quick hitch only)	55	20892	2	Castle nut metric, M24 x 2 (BB48, BB60, BB72)(S/N 994127 & after)
23	2855	*2	5/8 x 2 Carriage bolt GR5	55	39323	1	Castle nut metric M30 x 2 BB84
24	33661	2	Cat. 1 Mounting pin (with nut & lock washer; does not include 53) (BB48, BB60, BB72)	56	*	*1	6" Wire, 9 gauge
24	30006	2	Cat. 2 Mounting pin (with nut & lock washer; Does not include 53) (BB84)	57	15345	1	Retaining ring, .05 x 1.38
25	24801	4	M8 x 1.25P x 20 mm Cap screw	NS	15358	1	Safety decal set
26	35155	*4	5/16 Flat washer	NS	1000624	1	Complete decal set
27	2472	*4	5/16 Lock washer			*	Standard hardware, obtain locally
28	1002048	1	Clutch shield, 100 & 143 mm BC			NS	Not Shown
29	57403	1	Complete drive asy - BB72 (page 42)				
29	1020901	1	Complete drive asy - BB72				

**GEARBOX ASSEMBLY
(BB48, BB60, BB72 ALL SERIAL NUMBERS)
(BB84-S/N 827627 & AFTER)**

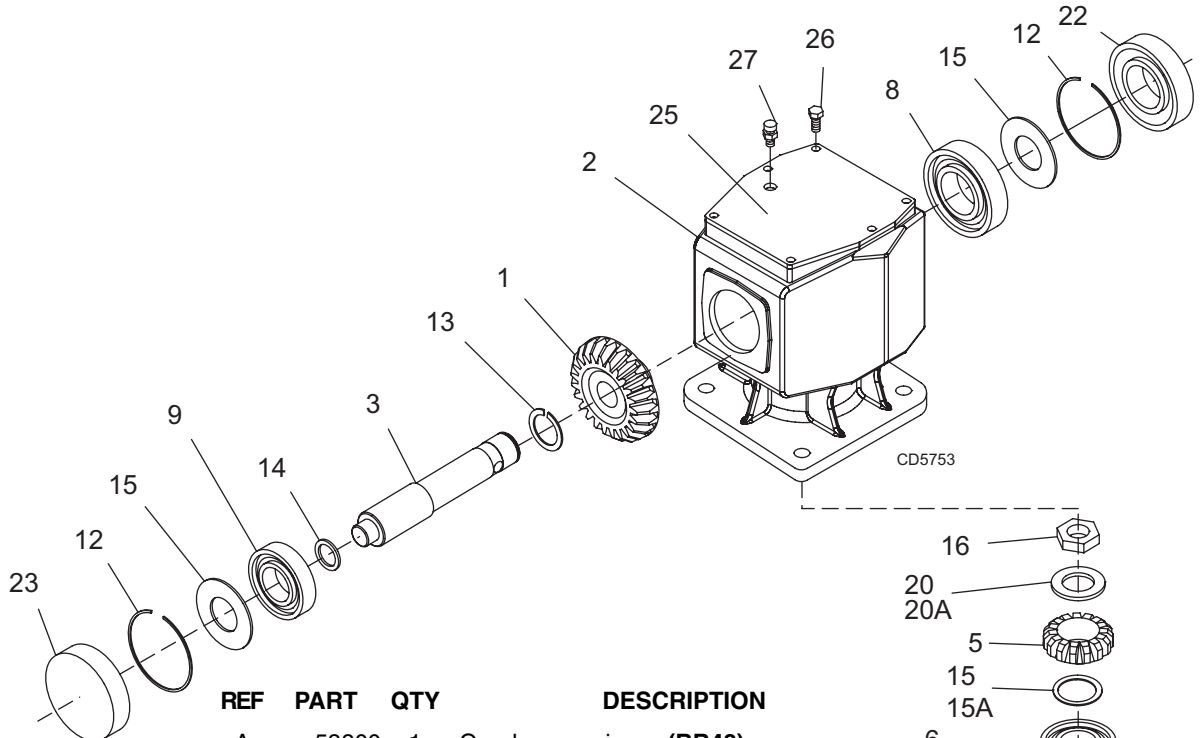

REF	PART	QTY	DESCRIPTION
A	58800	1	Gearbox repair asy. (BB48)
A	58801	1	Gearbox repair asy. (BB60)
A	58802	1	Gearbox repair asy. (BB72)
A	58803	1	Gearbox repair asy. (BB84)
1	57458	1	Gear crown 25T (BB48)
1	57459	1	Gear crown 24T (BB60)
1	57460	1	Gear crown 22T (BB72)
1	39424	1	Gear crown 19T (BB84)
2	NS	1	Gearbox housing
3	57464	1	Input shaft 1-3/8 smooth shaft (BB48 & 60)
3	57465	1	Input shaft 1-3/8 - 6 spline (BB72)
3	57147	1	Input shaft 1-3/8 - 6 spline (BB84)
4	57489	1	Output shaft (BB48 & 60)
4	57490	1	Output shaft (BB72)
4	57191	1	Output shaft (BB84)
5	57491	1	Gear pinion 13T M5.3 (BB48)
5	57497	1	Gear pinion 14T M5.3 (BB60)
5	57498	1	Gear pinion 15T M5.7 (BB72)
5	39418	1	Gear pinion 15T M6.5 (BB84)
6	57476	1	Bearing cup & cone (BB48 & 60)
6	39257	1	Bearing cup & cone (BB72)
6	39263	1	Bearing cup & cone (BB84)
7	57478	1	Bearing cup & cone (BB48, BB60, BB72)
7	39263	1	Bearing cup & cone (BB84)
8	57462	1	Bearing cup & cone

GEARBOX ASSEMBLY PARTS LIST (CONT'D)

REF	PART	QTY	DESCRIPTION	REF	PART	QTY	DESCRIPTION
9	20890	1	Bearing-Ball 6207	20A	57094	1	Shim kit 44 x 30.3 x 1 (BB84)
10	20897	1	Ring retainer 81mm internal (BB48, BB60, BB72)	20	57473	1	Flat washer 21 x 37 x 3 (BB48 & BB60)
11		*1	Cotter pin	20	57474	1	Flat washer 25 x 48 x 2.5 (BB72)
12	57466	2	Snap ring	21	20900	1	Seal, metric 40 x 80 x 12 (BB48, BB60, BB72)
13	57467	1	Snap ring (BB48, BB60, BB72)	21	39289	1	Dust lip 50 x 90 x 10 (BB84)
14	57373	1	Spacer 35.3 x 48 x 2.5 (BB48, BB60, BB72)	22	57463	1	Oil seal 35 x 72 x 10
15	57328	2	Gearbox shim kit	23	57374	1	Oil cap
15A	57471	1	Shim kit 50.3 x 70.3 (BB84)	25	57375	1	Top cover (BB48 & 60)
16	57468	1	Castle nut (BB48 & BB60)	25	57376	1	Top cover (BB72)
16	57469	1	Castle nut (BB72)	25	57139	1	Top cover (BB84)
16	39261	1	Castle nut (BB84)	26		*6	M8 x 16 Hex head cap screw CL8.8 (BB48, BB60, BB72)
17	20892	1	Castle nut metric M24 x 2 (BB48, BB60, BB72)	26		*6	M8 x 14 Hex head cap screw CL8.8 (BB84)
17	39323	1	Castle nut metric M30 x 2 (BB84)	27	57076	1	Vent plug 1/2 NPT
18	20893	1	Washer 25 x 44 x 4 mm (BB48, BB60, BB72)	28		*1	6" Wire, 9 gauge - or -
18	39322	1	Washer 31 x 56 x 4 mm (BB84)	28		1	Cotter pin
19	57475	1	Protective washer(BB48, BB60, BB72)				NS = Not Serviced
19A	57338	1	Screen protection (BB84)			*	Standard hardware, obtain locally

CHECK CHAIN ASSEMBLY (OPTIONAL)

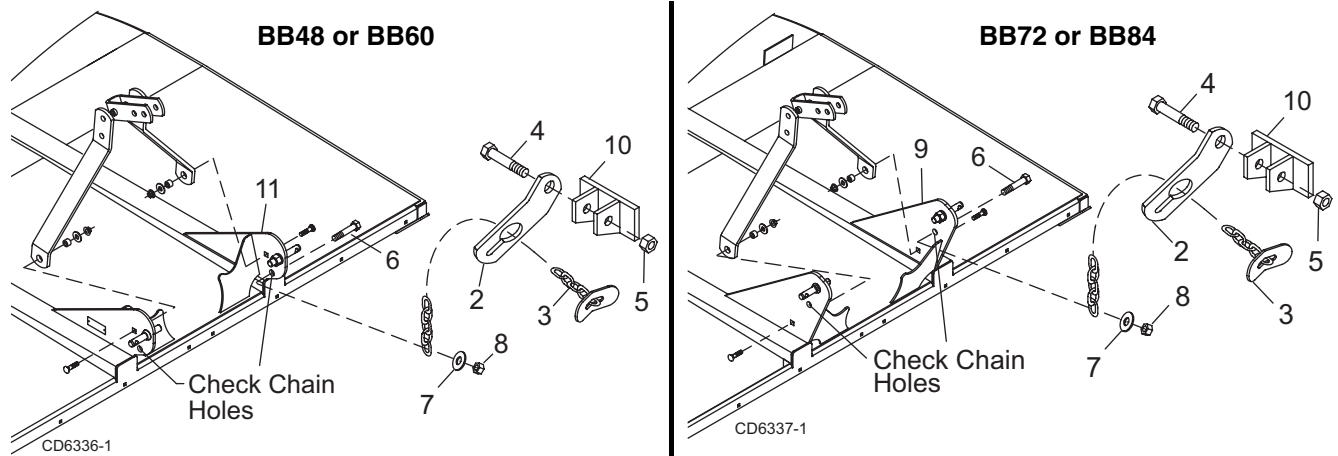

REF	PART	QTY	DESCRIPTION	REF	PART	QTY	DESCRIPTION
	10521	1	Check chain complete	7	3632	*	5/8 Standard flat washer
2	7906	2	Check chain bracket, lower	8	6239	*	5/8 NC Hex nut
3	18048	2	3/8 Chain, 32-Link and check lug	9			Mast plate BB48 or BB60
4	2377	*	3/4 NC x 6 Hex head cap screw GR5	10			Tractor top link bracket
5	2371	*	3/4 NC Hex lock nut	11			Mast plate BB72 or BB84
6	12274	*	5/8 NC x 2-1/4 Hex head cap screw GR5			*	Standard hardware, obtain locally

GEARBOX ASSEMBLY (BB84-S/N 827626 & PRIOR)

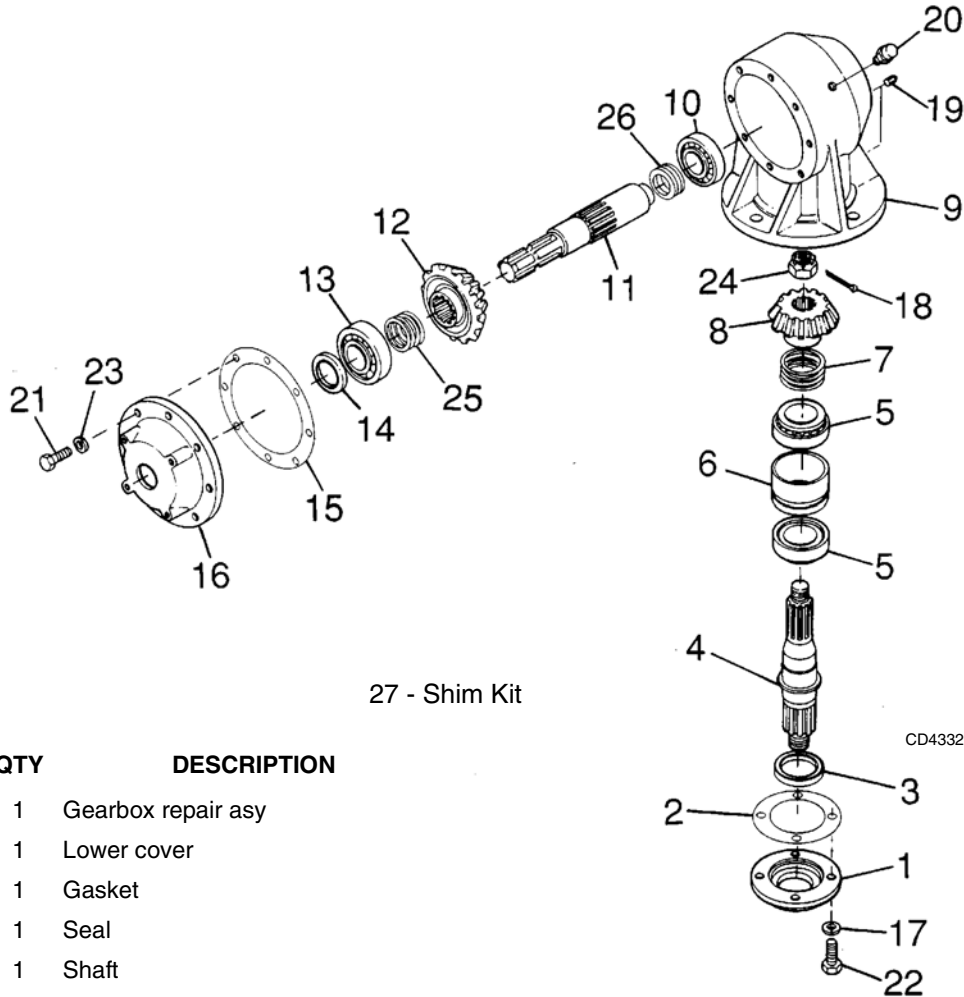

27 - Shim Kit

REF	PART	QTY	DESCRIPTION
A	39124	1	Gearbox repair asy
1	39421	1	Lower cover
2	39323	1	Gasket
3	39420	1	Seal
4	39416	1	Shaft
5	39263	2	Bearing
6	39417	1	Spacer
7	—	A/R	Shim, 45.3 mm ID x 65.3 mm OD
8	39418	1	Pinion gear, 15-tooth
9	—		Gearbox housing (not sold separately)
10	39414	1	Bearing
11	39415	1	Shaft
12	39424	1	Gear, 19-tooth
13	39425	1	Bearing
14	39427	1	Seal
15	39426	1	Gasket
16	39428	1	Front cover
17	39422	4	10 mm Lock washer
18	64291	1	5/32 x 1 Cotter pin
19	65294	1	3/8 NPT Square head pipe plug
20	39325	1	3/8 NPT Vented plug

REF	PART	QTY	DESCRIPTION
21	24801	8	8 mm x 1.25P x 20 mm Hex head cap screw
22	24802	4	10 mm x 1.25P x 25 mm Hex head cap screw
23	2472	8	5/16 Standard lock washer
24	39261	1	30 mm x 1.50 Hex castle nut
25	—	A/R	Shim, 40.3 mm ID x 51.5 mm OD
26	—	A/R	Shim, 35.3 mm ID x 43.0 mm OD
27	39413	A/R	Shim kit (includes items 7, 25, 26)

A/R = As Required

CD4332

BB72 COMER SLIP CLUTCH DRIVELINE ASSEMBLY

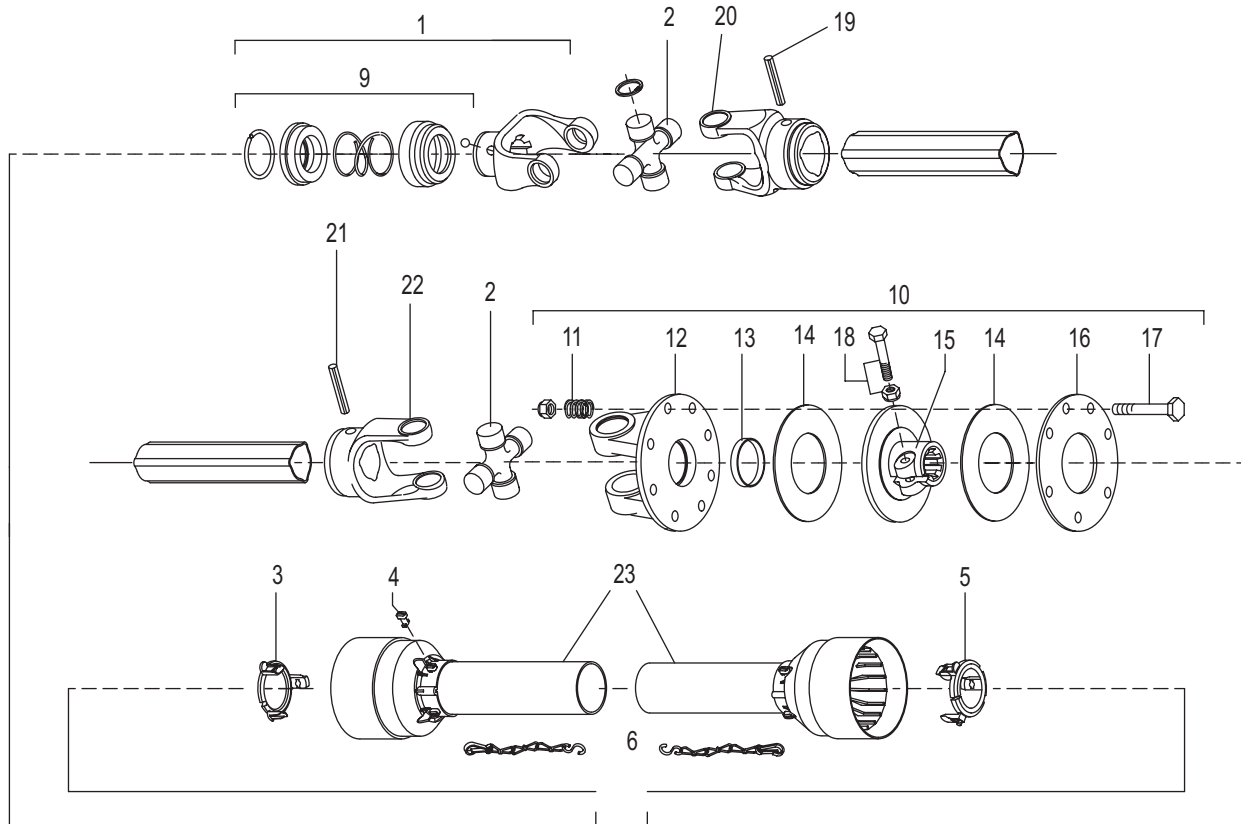

NOTE: EXAMINE THE DRIVELINE PROFILE TO DETERMINE THE CORRECT REPAIR PARTS FOR THE UNIT

CD6937

WALTERSCHIED
PROFILE

COMER
PROFILE



PG 42

PG 41

REF	PART	QTY	DESCRIPTION	REF	PART	QTY	DESCRIPTION
-	1020901	1	Complete 540 driveline asy	13	1001313	1	Bushing
1	1001300	2	Complete collar yoke C12 1-3/8 - 6	14	1001314	2	Lining ring
2	38478	2	Cross and bearing kit	15	1001316	1	Flanged hub F12
3	1019442	1	Outer cone fix ring	16	1001317	1	Pressure plate
4	30922	6	Protection fixing screw	17	1001318	8	Bolt & nut M10 x 80
5	1019444	1	Inner cone fix ring	18	1001315	1	Bolt & nut M12 x 1.25 x 65
6	30917	2	Chain-shield tether	19	1001302	1	Flexible pin
9	1001340	1	Lock collar repair kit	20	1001301	1	Outer yoke tube
10	1019449	1	Friction clutch	21	1001305	1	Flexible pin
11	1001311	8	Spring	22	1001306	1	Inner tube yoke
12	1001312	1	Flanged yoke	23	1021552	1	Shield, complete

BB72 & BB84 WALTERSCHIED SLIP CLUTCH DRIVELINE ASSEMBLY

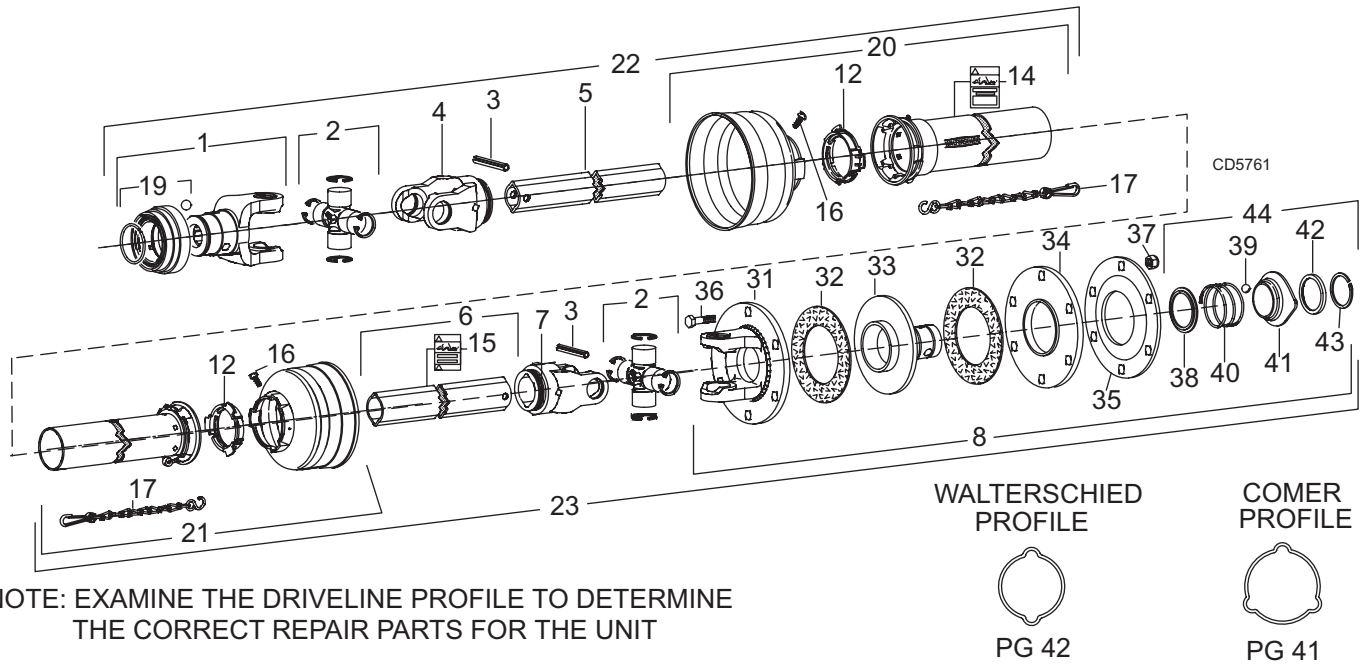

NOTE: EXAMINE THE DRIVELINE PROFILE TO DETERMINE THE CORRECT REPAIR PARTS FOR THE UNIT

REF	QTY	PART BB72	PART BB84	DESCRIPTION
	1	57403	57409	Complete 540 driveline assembly
1	1	40571	40574	Yoke 1-3/8 - 6 spline
2	2	154	110	Cross & bearing kit
3	2	40775	40764	Spring pin 10 x 65
4	1	40572	40575	Inboard yoke
5	1	40583	40587	Inner profile
6	1	40592	40588	Outer profile
7	1	40573	40576	Inboard yoke
8	1	57405	57412	Friction slip clutch
12	2	40776	40766	Bearing ring SC25
14	1	18864	18864	Danger decal, rotating driveline
15	1	33347	33347	Danger decal, shield missing
16	2	40778	40778	Screw, included in items 9 & 13
17	2	40777	40777	Anti-rotation chain
19	1	40589	40589	Slide collar kit
20	1	40759	40590	Outer guard half
21	1	40760	40591	Inner guard half
22	1	40736	57410	Shaft assembly, male (complete with guard)
23	1	57404	57411	Shaft assembly, female (complete with guard)
31	1	57431	57438	Flange yoke
32	2	57432	57432	Friction disc
33	1	57436	57436	Hub, 1-3/8" spline
34	1	57434	57434	Thrust plate
35	1	57435	57439	Belleville spring plate
36	6	57259	57259	10 mm x 1.5P x 50 mm Cap screw
37	6	57260	57260	10 mm x 1.5P Hex lock nut
38	1	---	---	Back-up ring
38	3	---	---	Ball
40	1	---	---	Compression spring
41	1	---	---	Lock collar
42	1	---	---	Back-up ring
43	1	---	---	Snap ring
44	1	57437	57437	QD flange service kit (items 38-43)

BB48 COMER STANDARD DRIVELINE ASSEMBLY

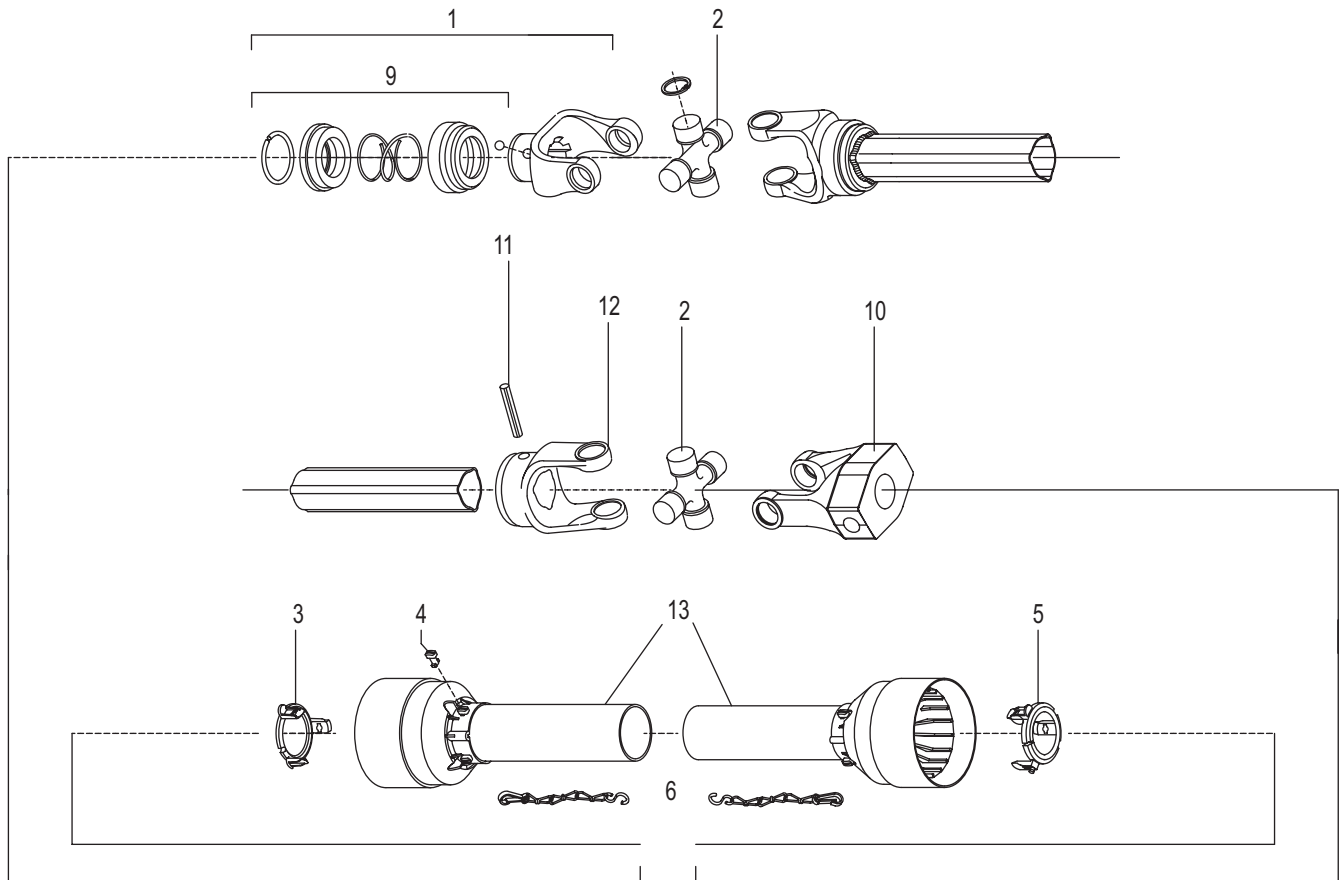

NOTE: EXAMINE THE DRIVELINE PROFILE TO DETERMINE THE CORRECT REPAIR PARTS FOR THE UNIT

CD6934

WALTERSCHIED
PROFILE



PG 45

COMER
PROFILE



PG 43

REF	PART	QTY	DESCRIPTION	REF	PART	QTY	DESCRIPTION
-	1009509	1	Complete 540 driveline asy	6	30917	2	Chain shield tether
1	1001300	2	Complete collar yoke C12 1-3/8 - 6	9	1001340	1	Lock collar repair kit
	38478	2	Cross & bearing kit	10	1019445	1	Special drive yoke
3	1019442	1	Outer cone fix ring	11	1001305	1	Flexible pin
4	30922	6	Protection fixing screw	12	1001306	1	Inner tube yoke
5	1019444	1	Inner cone fix ring	13	1021324	1	Shield, complete

BB60 COMER STANDARD DRIVELINE ASSEMBLY

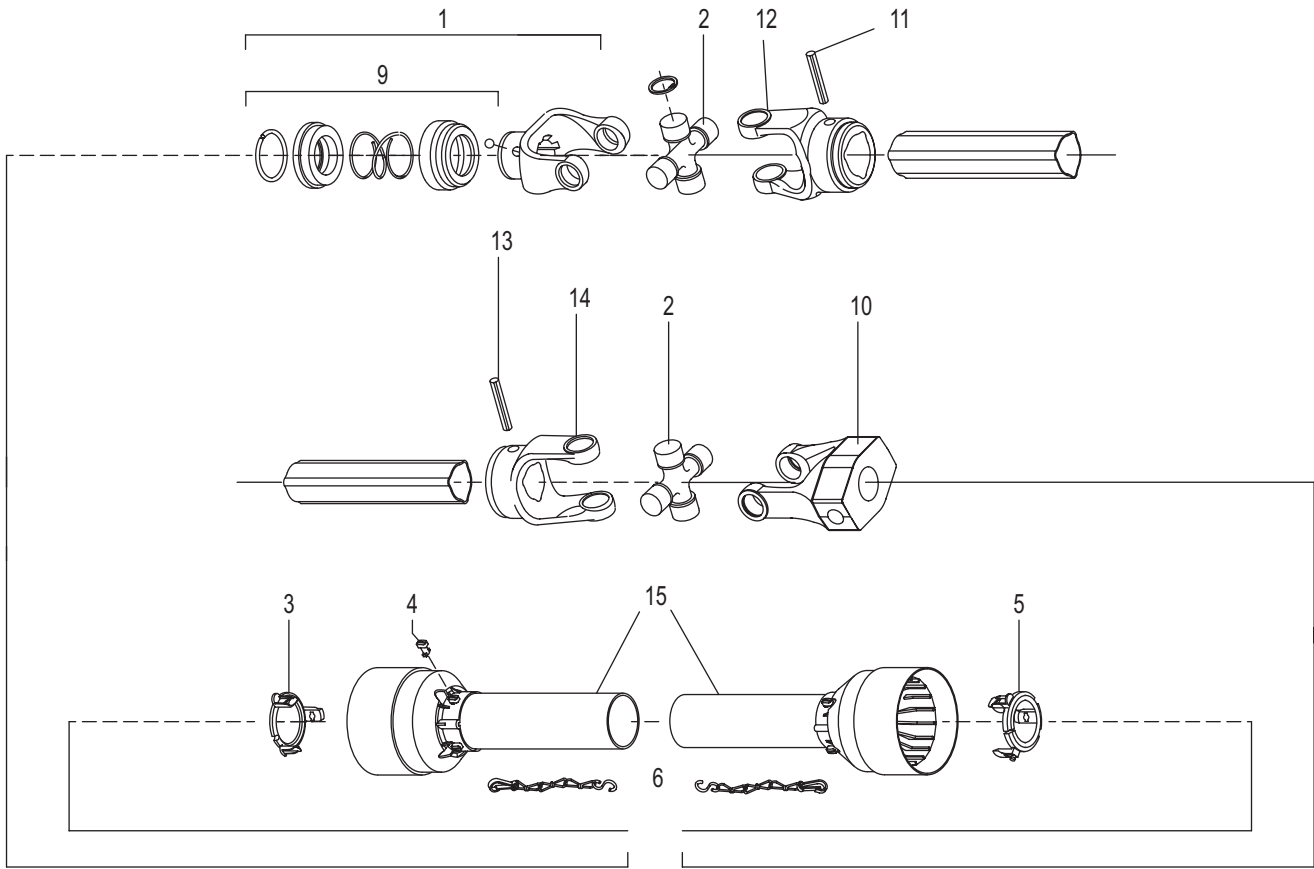

CD6935

WALTERSCHIED
PROFILE



PG 45

COMER
PROFILE



PG 44

REF	PART	QTY	DESCRIPTION	REF	PART	QTY	DESCRIPTION
-	1009510	1	Complete 540 driveline	9	1001340	1	Lock collar repair kit
1	1001300	2	Complete collar yoke C12 1-3/8 - 6	10	1019445	1	Special drive yoke
2	38478	2	Cross & bearing kit	11	1001302	1	Flexible pin
3	1019442	1	Outer cone fix ring	12	1001301	1	Outer yoke tube
4	30922	6	Protection fixing screw	13	1001305	1	Flexible pin
5	1019444	1	Inner cone fix ring	14	1001306	1	Inner tube yoke
6	30917	2	Chain shielding tether	15	1021550	1	Shield, complete

44 Parts

(Rev. 10/27/2006)
MAN0050 (Rev. 1/21/2005)

BB48 & BB60 WALTERSCHEID STANDARD DRIVELINE ASSEMBLY

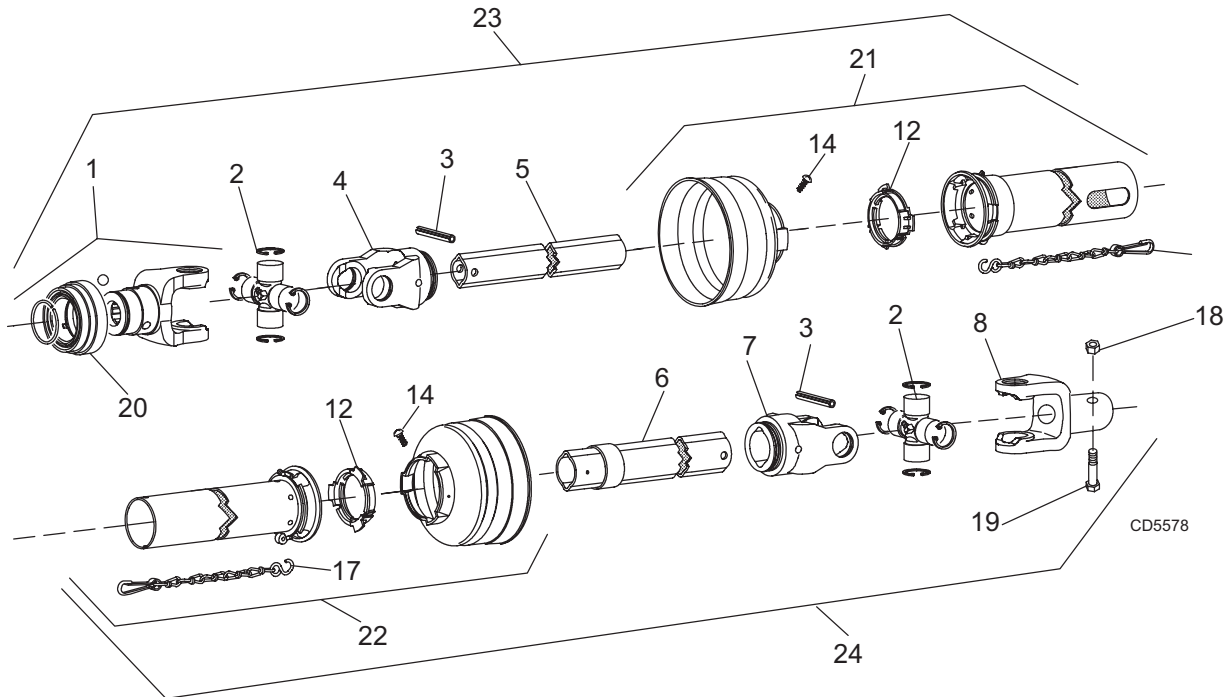

NOTE: EXAMINE THE DRIVELINE PROFILE TO DETERMINE THE CORRECT REPAIR PARTS FOR THE UNIT

WALTERSCHEID
PROFILE

COMER
PROFILE



PG 45



PG 43 & 44

REF	PART	QTY	DESCRIPTION	REF	PART	QTY	DESCRIPTION
	40554	1	Complete 540 driveline assembly (shear bolt) BB48 only	17	40777	2	Anti-rotation chain
	40555	1	Complete 540 driveline assembly (shear bolt) BB60 only	18	765	1	1/2 NC Lock nut
1	40571	1	Yoke, 1-3/8 - 6 SP (complete with lock collar)	19	15349	1	1/2 NC x 3 Shear bolt
2	154	2	Cross and bearing kit	20	40589	2	Lock collar repair kit (without yoke)
3	40775	2	Spring pin 10 mm x 65 mm (pkg. of 10)	21	40759	1	Guard, outer half, includes items 12, 13, and 14 (cut to length)
4	40572	1	Inboard yoke (male drive tube)	22	40761	1	Guard, inner half includes items 12, 13, and 17
5	40583	1	Inner profile (cut to length)	23	40739	1	BB48 Shaft assembly, male half (complete with guard)
6	40592	1	Outer profile (cut to length)	23	40733	1	BB60 Shaft assembly, male half (complete with guard)
7	40573	1	Inboard yoke (female drive tube)	24	40740	1	BB48 Shaft assembly, female half, (complete with guard and shear bolt yoke)
8	40580	1	Yoke, shear bolt	24	40734	1	BB60 Shaft assembly, female half, (complete with guard and shear bolt yoke)
12	40776	2	Bearing ring (pkg. of 2)				
14	40778	2	Screw (pkg. of 2)				

BB48 & BB60 COMER SLIP CLUTCH DRIVELINE ASSEMBLY (OPTIONAL)

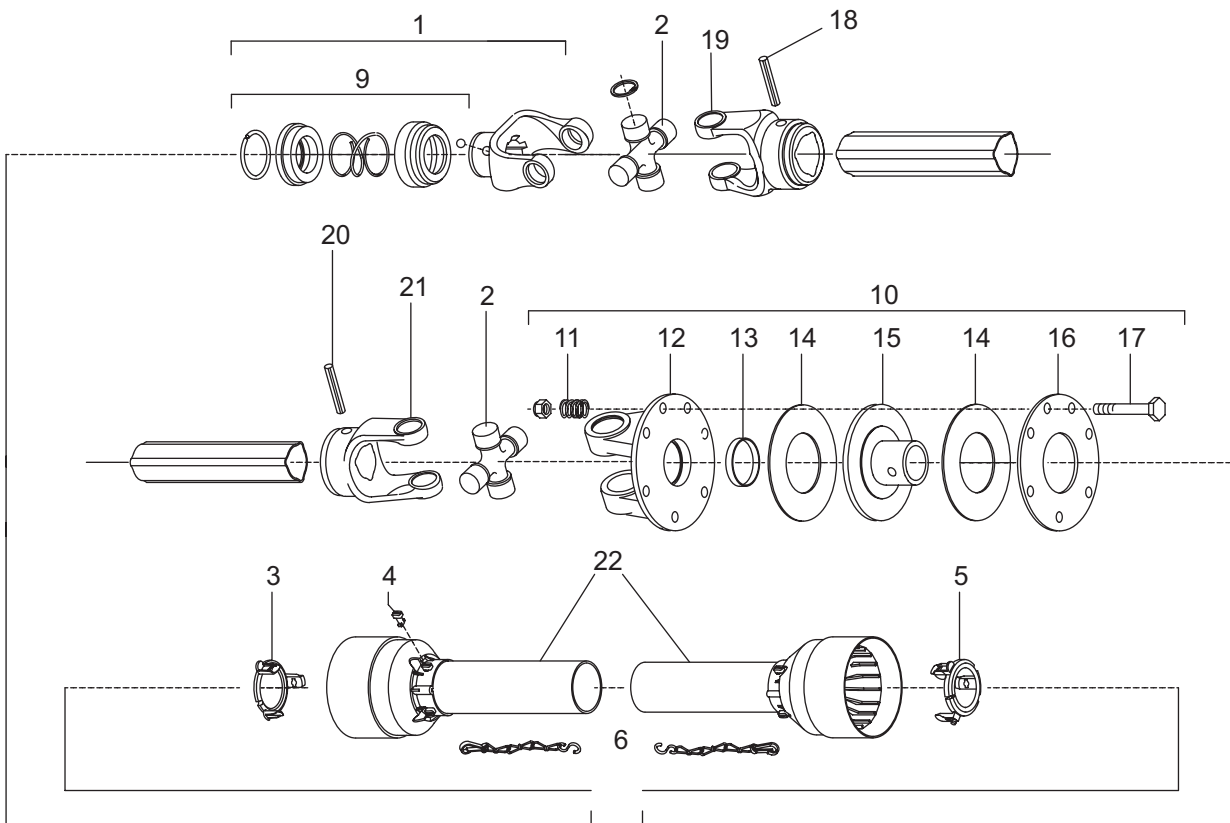

NOTE: EXAMINE THE DRIVELINE PROFILE TO DETERMINE THE CORRECT REPAIR PARTS FOR THE UNIT

CD6936

WALTERSCHIED
PROFILE

COMER
PROFILE



PG 47

PG 46

REF	PART	QTY	DESCRIPTION	REF	PART	QTY	DESCRIPTION
-	1020900	1	Complete 540 driveline assembly	12	1019447	1	Flanged yoke
1	1001300	2	Complete collar yoke C12 1-3/8 - 6	13	1001313	1	Bushing
2	38478	2	Cross & bearing kit	14	1001314	2	Lining ring
3	1019442	1	Outer cone fix ring	15	1019448	1	Special hub F10
4	30922	6	Protection fixing ring	16	1001317	1	Pressure plate
5	1019444	1	Inner come fix ring	17	1001318	8	Bolt & nut M10 x 80
6	30917	2	Chain shield tether	18	1001302	1	Flexible pin
9	1001340	1	Lock collar repair kit	19	1001301	1	Outer yoke tube
10	1019446	1	Special friction clutch	20	1001305	1	Flexible pin
11	1001311	8	Spring	21	1001306	1	Inner tube yoke
				22	1021551	1	Shield, complete

46 Parts

(Rev. 10/27/2006)
MAN0050 (Rev. 1/21/2005)

BB48 & BB60 WALTERSCHIED SLIP CLUTCH DRIVELINE ASSEMBLY (OPTIONAL)

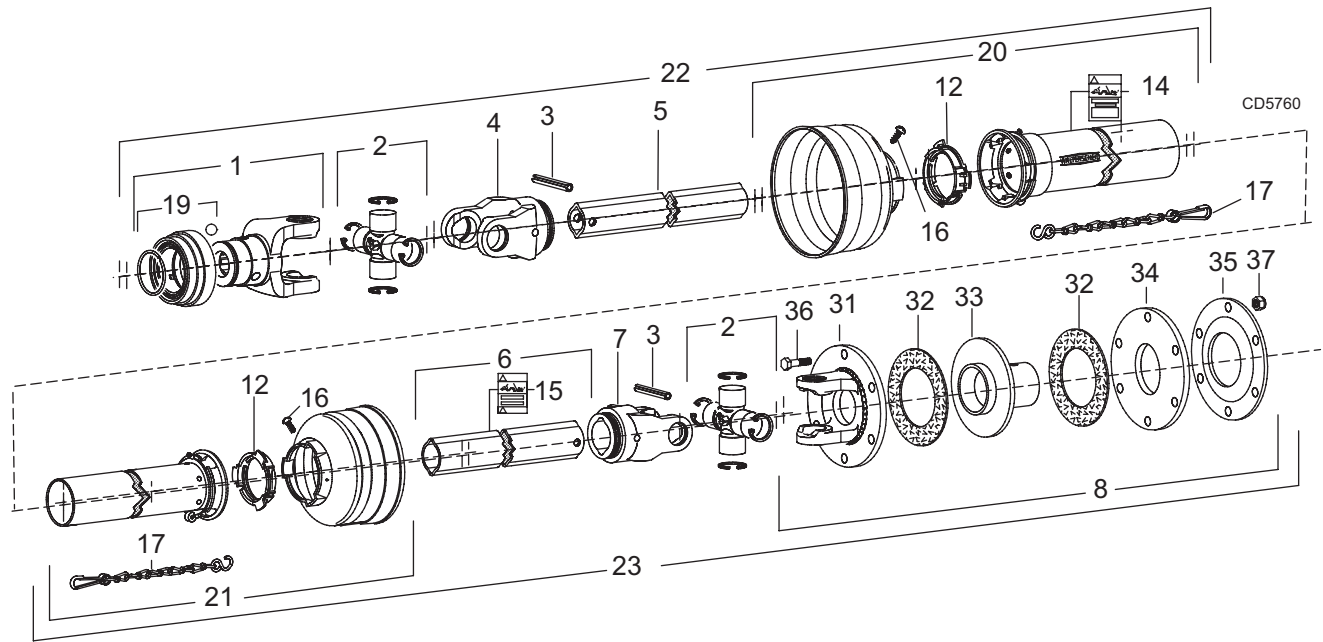

NOTE: EXAMINE THE DRIVELINE PROFILE TO DETERMINE THE CORRECT REPAIR PARTS FOR THE UNIT

WALTERSCHIED PROFILE

COMER PROFILE



PG 47



PG 46

REF	PART	QTY	DESCRIPTION	REF	PART	QTY	DESCRIPTION
	57400	1	Complete 540 driveline assembly	20	40759	1	Outer guard half
1	40571	1	Yoke 1-3/8 - 6 spline	21	40760	1	Inner guard half
2	154	2	Cross & bearing kit	22	40733	1	Shaft assembly, male (complete with guard)
3	40775	2	Spring pin 10 mm x 65 mm	23	57401	1	Shaft assembly, female (complete with guard)
4	40572	1	Inboard yoke	31	57431	1	Flange yoke
5	40583	1	Inner profile	32	57432	2	Friction disc
6	40592	1	Outer profile	33	57433	1	Hub, 1-3/8" round bore
7	40573	1	Inboard yoke	34	57434	1	Thrust plate
8	57402	1	Friction slip clutch	35	57435	1	Belleville spring plate
12	40776	2	Bearing ring SC15	36	57259	6	10 mm x 1.5P x 50 mm Cap screw GR 8.8
14	18864	1	Decal, danger rotating driveline	37	57260	6	10 mm x 1.5P Hex lock nut (w/nylon insert)
15	33347	1	Decal, danger guard missing				
16	40778	2	Screw, included in items 9 & 13				
17	40777	2	Anti-rotation chain				
19	40589	1	Slide collar kit				

FRONT & REAR CHAIN SHIELDING (OPTIONAL)

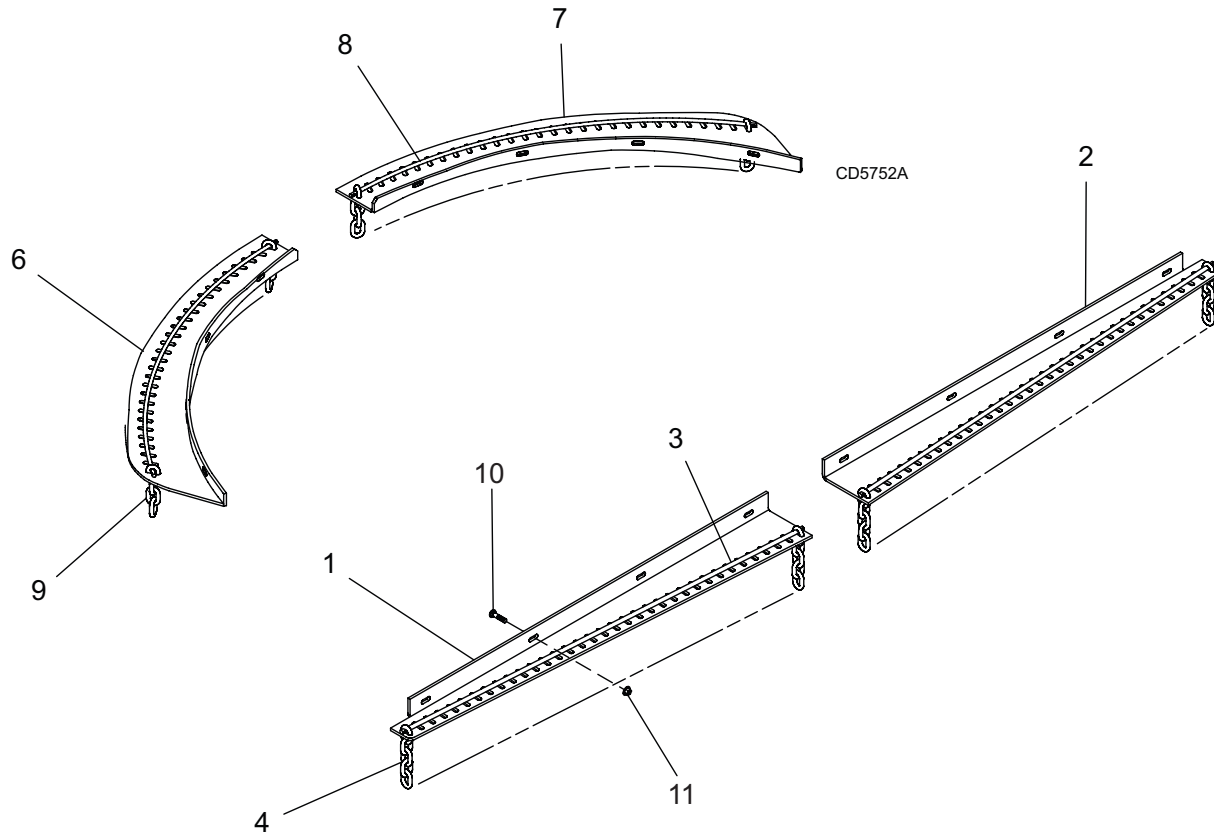

REF	QTY	PART BB48	PART BB60	PART BB72	PART BB84	DESCRIPTION
1	1	57246	57143	57090	57128	Right front chain plate
2	1	57254	57144	57091	57127	Left front chain plate
3	2	1003643	1003645	1007850	1007851	.243 Dia. bent pin (front)
4	AR	5496	5496	5496	5496	5/16 - 7 Link chain (front)
6	1	57248	57142	57088	57125	Right rear chain plate
7	1	57247	57141	57089	57149	Left rear chain plate
8	2	57249	57138	57085	57146	.243 Dia. rolled bent pin (rear)
9	AR	4069	4069	4069	4069	5/16 - 4 Link chain (rear)
10	16	6697*	6697*	6697*	6697*	3/8 NC x 1 Carriage bolt
11	16	14350	14350	14350	14350	3/8 NC Flange hex nut

AR = As Required

* Standard hardware, obtain locally

48 Parts

(Rev. 10/27/2006)
MAN0050 (Rev. 1/21/2005)

RUBBER SHIELDING (OPTIONAL)

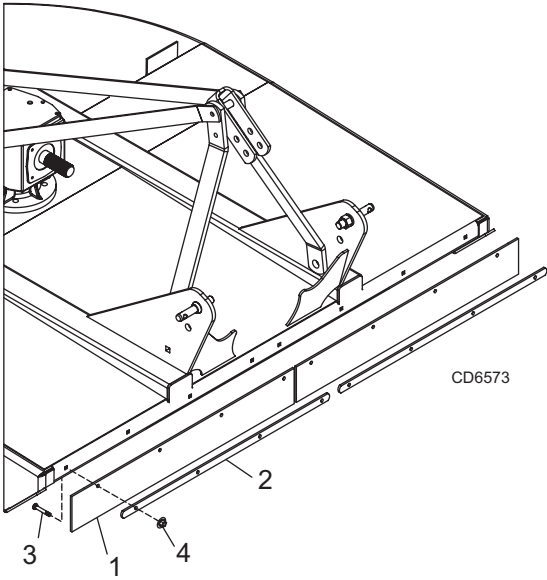

REF	PART	QTY	DESCRIPTION
	1013207	1	Rubber shield kit - BB48 (includes items 1-4)
	1013208	1	Rubber shield kit 5 ft - BB60 (includes items 1-4)
	1013209	1	Rubber shield kit 6 ft - BB72 (includes items 1-4)
	1013210	1	Rubber shield kit 7 ft - BB84 (includes items 1-4)
1	1004128	2	Rubber deflector 25.25 - BB48
1	1004129	2	Rubber deflector 31.25 - BB60
1	1004130	2	Rubber deflector 37.25 - BB72
1	1004131	2	Rubber deflector 43.25 - BB84
2	1013213	2	Link .25 x 1.00 x 21.50 - BB48
2	1013214	2	Link .25 x 1.00 x 28.75 - BB60
2	1013215	2	Link .25 x 1.00 x 34.75 - BB72
2	1013216	2	Link .25 x 1.00 x 40.50 - BB84
3	6697*	8	3/8NC x 1 Carriage bolt
4	14350	8	3/8NC Flange hex nut

* Standard Hardware - Obtain Locally

BOLT TORQUE CHART

Always tighten hardware to these values unless a different torque value or tightening procedure is listed for a specific application.

Fasteners must always be replaced with the same grade as specified in the manual parts list.

Always use the proper tool for tightening hardware: SAE for SAE hardware and Metric for metric hardware.

Make sure fastener threads are clean and you start thread engagement properly.

All torque values are given to specifications used on hardware defined by SAE J1701 MAR99 & J1701M JUL96.

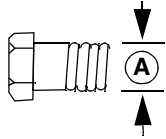

SAE SERIES TORQUE CHART

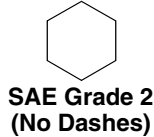

SAE Bolt Head Identification



A Diameter (Inches)	Wrench Size	MARKING ON HEAD					
		SAE 2		SAE 5		SAE 8	
		lbs-ft	N-m	lbs-ft	N-m	lbs-ft	N-m
1/4"	7/16"	6	8	10	13	14	18
5/16"	1/2"	12	17	19	26	27	37
3/8"	9/16"	23	31	35	47	49	67
7/16"	5/8"	36	48	55	75	78	106
1/2"	3/4"	55	75	85	115	120	163
9/16"	13/16"	78	106	121	164	171	232
5/8"	15/16"	110	149	170	230	240	325
3/4"	1-1/8"	192	261	297	403	420	569
7/8"	1-5/16"	306	416	474	642	669	907
1"	1-1/2"	467	634	722	979	1020	1383

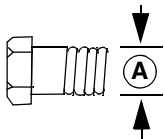

METRIC SERIES TORQUE CHART

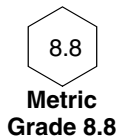

Metric Bolt Head Identification

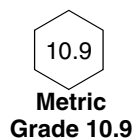

A Diameter & Thread Pitch (Millimeters)	Wrench Size	COARSE THREAD				FINE THREAD				A Diameter & Thread Pitch (Millimeters)
		MARKING ON HEAD				MARKING ON HEAD				
		Metric 8.8		Metric 10.9		Metric 8.8		Metric 10.9		
		N-m	lbs-ft	N-m	lbs-ft	N-m	lbs-ft	N-m	lbs-ft	
6 x 1.0	10 mm	8	6	11	8	8	6	11	8	6 x 1.0
8 x 1.25	13 mm	20	15	27	20	21	16	29	22	8 x 1.0
10 x 1.5	16 mm	39	29	54	40	41	30	57	42	10 x 1.25
12 x 1.75	18 mm	68	50	94	70	75	55	103	76	12 x 1.25
14 x 2.0	21 mm	109	80	151	111	118	87	163	120	14 x 1.5
16 x 2.0	24 mm	169	125	234	173	181	133	250	184	16 x 1.5
18 x 2.5	27 mm	234	172	323	239	263	194	363	268	18 x 1.5
20 x 2.5	30 mm	330	244	457	337	367	270	507	374	20 x 1.5
22 x 2.5	34 mm	451	332	623	460	495	365	684	505	22 x 1.5
24 x 3.0	36 mm	571	421	790	583	623	459	861	635	24 x 2.0
30 x 3.0	46 mm	1175	867	1626	1199	1258	928	1740	1283	30 x 2.0

Typical Washer Installations

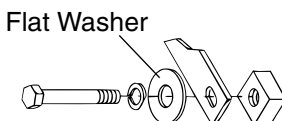
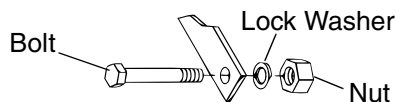

8/9/00

BOLT SIZE CHART

NOTE: Chart shows bolt thread sizes and corresponding head (wrench) sizes for standard SAE and metric bolts.

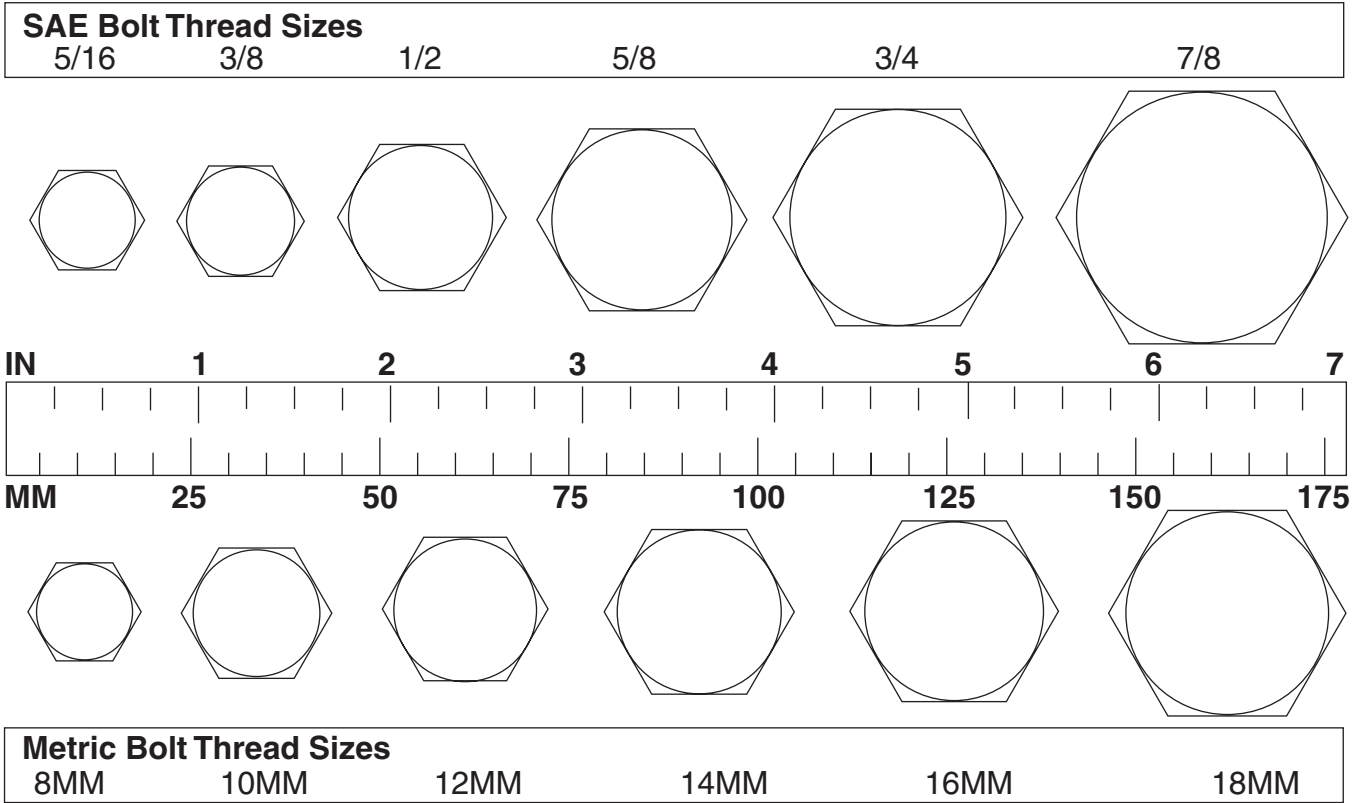

ABBREVIATIONS

AG.....	Agriculture	NC.....	National Coarse
ATF.....	Automatic Transmission Fluid	NF.....	National Fine
BSPP.....	British Standard Pipe Parallel	NPSM.....	National Pipe Straight Mechanical
BSPTM.....	British Standard Pipe Tapered Male	NPT.....	National Pipe Tapered
CV.....	Constant Velocity	NPT SWF.....	National Pipe Tapered Swivel Female
CCW.....	Counter-Clockwise	ORBM.....	O-Ring Boss - Male
CW.....	Clockwise	P.....	Pitch
F.....	Female	PBY.....	Power-Beyond
GA.....	Gauge	psi.....	Pounds per Square Inch
GR (5, etc.).....	Grade (5, etc.)	PTO.....	Power Take Off
HHCS.....	Hex Head Cap Screw	QD.....	Quick Disconnect
HT.....	Heat-Treated	RH.....	Right Hand
JIC.....	Joint Industry Council 37° Degree Flare	ROPS.....	Roll-Over Protective Structure
LH.....	Left Hand	RPM.....	Revolutions Per Minute
LT.....	Left	RT.....	Right
m.....	Meter	SAE.....	Society of Automotive Engineers
mm.....	Millimeter	UNC.....	Unified Coarse
M.....	Male	UNF.....	Unified Fine
MPa.....	Mega Pascal	UNS.....	Unified Special
N.....	Newton		

INDEX

ASSEMBLY

- Assemble Cutter 29
 - Disassemble Shipping Unit 29
 - Install A-Frame 30
 - Install A-Frame to Diagonal Brace Bars 31
 - Install Tailwheel 30
 - Quick Hitch Set-Up 31
- Dealer Set-up Instructions 28
- Fill Gearbox 32
- Install Driveline 31
 - Install Driveline Shear Bolt BB48 & BB60 Only 31
 - Install Driveline Slip Clutch 32
- Install Optional Check Chains 33
- Install Safety Shielding
 - Install Rubber Deflector & Foot Guard 32

DEALER CHECK LIST

- Delivery Check (Dealer's Responsibility) 27
- Pre-Delivery Check List (Dealer's Responsibility) 27

DEALER SERVICE

- Crossbar
 - Install Crossbar 25
 - Remove Crossbar 24
- Gearbox Maintenance 18
 - Horizontal Leak Repair
 - (BB48, BB60, BB72, all Serial Numbers) 19
 - (BB84 - S/N 827627and after) 19
 - Seal Installation 18
 - Seal Replacement 18
 - Vertical Shaft Repair
 - (BB48, BB60, BB72, all Serial Numbers) 18
 - (BB84 - S/N 827627and after) 18
- Gearbox Repair
 - Disassemble Gearbox
 - (BB48, BB60, BB72, all Serial Numbers) 19
 - (BB84 - S/N 827627and after) 19
 - (BB84 S/N 827626 & Prior) 22
 - Reassemble Gearbox
 - (BB48, BB60, BB72, all Serial Numbers) 20
 - (BB84 - S/N 827627and after) 20
 - (BB84 S/N 827627 & Prior) 22
 - Reinstall Gearbox
 - (BB48, BB60, BB72, all Serial Numbers) 20
 - (BB84 - S/N 827627and after) 20
 - (BB84 S/N 827626 & Prior) 22
 - Remove Gearbox
 - (BB48, BB60, BB72, all Serial Numbers) 19
 - (BB84 - S/N 827627and after) 19
- Universal Joint
 - Assembly 26
 - Disassembly 25
 - Repair 25

GENERAL

- Abbreviations 51
- Bolt Size Chart 51
- Bolt Torque Chart 50

- General Information 2
- Introduction, Inside Front Cover
- Obtaining Replacement Manuals, Inside Front Cover
- Specifications 2
- Table of Contents 1
- Warranty
 - Product 54
 - Replacement Parts 53

OPERATION

- Adjust Check Chains 11
- Adjust Cutting Height 9
- Adjust Top Link 9
- Attach Cutter to Tractor 9
- Attach Quick Hitch 10
- Install and Removal of Driveline 10
- Operating Technique 11
- Pre-Operation Check List
 - (Owner's Responsibility) 11
- Shredding Material 9
- Storage 11
- Tractor Stability 8

OWNER SERVICE

- Adjust Slip Clutch 15
- Blocking Method 12
- Cleaning
 - After Each Use 16
 - Periodically or Before Extended Storage 16
- Lubrication Information 13
 - Driveline Lubrication 13
 - Gearbox Lubrication 13
- Repair Shielding
 - Repair Front Guard and Rear Band 16
 - Repair Optional Chain Shielding 16
 - Repair Optional Rubber Shielding 16
- Replace Driveline Shear Bolt 16
- Service Blades
 - Install Blades 14
 - Remove Blades 14
 - Sharpen Blades 14
- Trouble Shooting 17

PARTS

- Index to Parts Lists 35

SAFETY

- Delivery Check List (Dealer's Responsibility) 27
- Pre-Delivery Check List (Dealer's Responsibility) 27
- Pre-Operation Check List
 - (Owner's Responsibility) 11
- Safety & Instructional Decals 6, 7
- Safety Rules 3, 4, 5
- Safety Symbols explained, Inside Front Cover
- Safety Video Order Form 3a



WARRANTY

(All Models Except Mow'n Machine™ Zero-Turn Mowers and Woods Boundary™ Utility Vehicles)

Please Enter Information Below and Save for Future Reference.

Date Purchased: _____

From (Dealer): _____

Model Number: _____

Serial Number: _____

Woods Equipment Company ("WOODS") warrants this product to be free from defect in material and workmanship. Except as otherwise set forth below, the duration of this Warranty shall be for TWELVE (12) MONTHS COMMENCING ON THE DATE OF DELIVERY OF THE PRODUCT TO THE ORIGINAL PURCHASER.

Woods backhoe models BH70-X, BH80-X, and BH90-X are warranted for two (2) years from the date of delivery to the original purchaser.

The warranty periods for specific parts or conditions are listed below:

Model Number	Part or Condition Warranted	Duration (from date of delivery to the original purchaser)
PHD25, PHD35, PHD65, PHD95, 1260, 2162, 3240, BB48, BB60, BB72, BB84, BB600, BB720, BB840, BB6000, BB7200, BB8400, BW180-2, BW1800, DS96, DS120, RCC42, RM550-2, RM660-2, RM990-3, PRD6000, PRD7200, PRD8400, 7144RD-2, 9180RD-2, 9204RD-2, S15CD, S20CD, S22CD, S25CD, S27CD	Gearbox components	5 years
RDC54, RD60, RD72	Gearbox components	3 years (1 year if used in rental or commercial applications)
RM550-2, RM660-2, RM990-3, PRD6000, PRD7200, PRD8400, 7144RD-2, 9180RD-2, 9204RD-2	Blade spindles	3 years
BB600, BB720, BB840, BB6000, BB7200, BB8400, BW126, BW180, BW1260, BW1800, 1260, 2162, 3240	Rust-through	10 years

Under no circumstances will this Warranty apply in the event that the product, in the good faith opinion of WOODS, has been subjected to improper operation, improper maintenance, misuse, or an accident. This Warranty does not apply in the event that the product has been materially modified or repaired by someone other than WOODS, a WOODS authorized dealer or distributor, and/or a WOODS authorized service center. This Warranty does not cover normal wear or tear, or normal maintenance items. This Warranty also does not cover repairs made with parts other than those obtainable through WOODS.

This Warranty is extended solely to the original purchaser of the product. Should the original purchaser sell or otherwise transfer this product to a third party, this Warranty does not transfer to the third party purchaser in any way. There are no third party beneficiaries of this Warranty.

WOODS makes no warranty, express or implied, with respect to engines, batteries, tires or other parts or accessories not manufactured by WOODS. Warranties for these items, if any, are provided separately by their respective manufacturers.

WOODS' obligation under this Warranty is limited to, at WOODS' option, the repair or replacement, free of charge, of the product if WOODS, in its sole discretion, deems it to be defective or in noncompliance with this Warranty. **The product must be returned to WOODS with proof of purchase within thirty (30) days after such defect or noncompliance is discovered or should have been discovered, routed through the dealer and distributor from whom the purchase was made, transportation charges prepaid.** WOODS shall complete such repair or replacement within a reasonable time after WOODS receives the product. THERE ARE NO OTHER REMEDIES UNDER THIS WARRANTY. THE REMEDY OF REPAIR OR REPLACEMENT IS THE SOLE AND EXCLUSIVE REMEDY UNDER THIS WARRANTY.

THERE ARE NO WARRANTIES WHICH EXTEND BEYOND THE DESCRIPTION ON THE FACE OF THIS WARRANTY. WOODS MAKES NO OTHER WARRANTY, EXPRESS OR IMPLIED, AND WOODS SPECIFICALLY DISCLAIMS ANY IMPLIED WARRANTY OF MERCHANTABILITY AND/OR ANY IMPLIED WARRANTY OF FITNESS FOR A PARTICULAR PURPOSE.

WOODS shall not be liable for any incidental or consequential losses, damages or expenses, arising directly or indirectly from the product, whether such claim is based upon breach of contract, breach of warranty, negligence, strict liability in tort or any other legal theory. Without limiting the generality of the foregoing, Woods specifically disclaims any damages relating to (i) lost profits, business, revenues or goodwill; (ii) loss of crops; (iii) loss because of delay in harvesting; (iv) any expense or loss incurred for labor, supplies, substitute machinery or rental; or (v) any other type of damage to property or economic loss.

This Warranty is subject to any existing conditions of supply which may directly affect WOODS' ability to obtain materials or manufacture replacement parts.

No agent, representative, dealer, distributor, serviceperson, salesperson, or employee of any company, including without limitation, WOODS, its authorized dealers, distributors, and service centers, is authorized to alter, modify, or enlarge this Warranty.

Answers to any questions regarding warranty service and locations may be obtained by contacting:

Woods Equipment Company

2606 South Illinois Route 2
Post Office Box 1000
Oregon, Illinois 61061

800-319-6637 tel
800-399-6637 fax
www.WoodsEquipment.com



ALITEC™

BMP®

CENTRAL FABRICATORS®

GANNON®

GILL®

WAIN-ROY®

WOODS®



WARRANTY

(Replacement Parts For All Models Except Mow'n Machine™
Zero-Turn Mowers and Woods Boundary™ Utility Vehicles)

Woods Equipment Company ("WOODS") warrants this product to be free from defect in material and workmanship for a period of ninety (90) days from the date of delivery of the product to the original purchaser with the exception of V-belts, which will be free of defect in material and workmanship for a period of 12 months.

Under no circumstances will this Warranty apply in the event that the product, in the good faith opinion of WOODS, has been subjected to improper operation, improper maintenance, misuse, or an accident. This Warranty does not cover normal wear or tear, or normal maintenance items.

This Warranty is extended solely to the original purchaser of the product. Should the original purchaser sell or otherwise transfer this product to a third party, this Warranty does not transfer to the third party purchaser in any way. There are no third party beneficiaries of this Warranty.

WOODS' obligation under this Warranty is limited to, at WOODS' option, the repair or replacement, free of charge, of the product if WOODS, in its sole discretion, deems it to be defective or in noncompliance with this Warranty. **The product must be returned to WOODS with proof of purchase within thirty (30) days after such defect or noncompliance is discovered or should have been discovered, routed through the dealer and distributor from whom the purchase was made, transportation charges prepaid.** WOODS shall complete such repair or replacement within a reasonable time after WOODS receives the product. THERE ARE NO OTHER REMEDIES UNDER THIS WARRANTY. THE REMEDY OF REPAIR OR REPLACEMENT IS THE SOLE AND EXCLUSIVE REMEDY UNDER THIS WARRANTY.

THERE ARE NO WARRANTIES WHICH EXTEND BEYOND THE DESCRIPTION ON THE FACE OF THIS WARRANTY. WOODS MAKES NO OTHER WARRANTY, EXPRESS OR IMPLIED, AND WOODS SPECIFICALLY DISCLAIMS ANY IMPLIED WARRANTY OF MERCHANTABILITY AND/OR ANY IMPLIED WARRANTY OF FITNESS FOR A PARTICULAR PURPOSE.

WOODS shall not be liable for any incidental or consequential losses, damages or expenses, arising directly or indirectly from the product, whether such claim is based upon breach of contract, breach of warranty, negligence, strict liability in tort or any other legal theory. Without limiting the generality of the foregoing, Woods specifically disclaims any damages relating to (i) lost profits, business, revenues or goodwill; (ii) loss of crops; (iii) loss because of delay in harvesting; (iv) any expense or loss incurred for labor, supplies, substitute machinery or rental; or (v) any other type of damage to property or economic loss.

This Warranty is subject to any existing conditions of supply which may directly affect WOODS' ability to obtain materials or manufacture replacement parts.

No agent, representative, dealer, distributor, service person, salesperson, or employee of any company, including without limitation, WOODS, its authorized dealers, distributors, and service centers, is authorized to alter, modify, or enlarge this Warranty.

Answers to any questions regarding warranty service and locations may be obtained by contacting:

WOODS®

ALITEC™
BMP®
CENTRAL FABRICATORS®
GANNON®
GILL®
WAIN-ROY®
WOODS®