

# SERVICE MANUAL

**AKAI TAPE RECORDER**

**MODEL X-360**

ALSO APPLICABLE FOR MODEL X-360D

## TABLE OF CONTENTS

I	SPECIFICATIONS . . . . .	1
II	MEASURING METHODS . . . . .	2
III	CONTROL LOCATIONS . . . . .	4
IV	DISMANTLING OF TAPE TRANSPORT UNIT & AMPLIFIERS . . . . .	5
V	MAGNETIC HEADS ADJUSTMENT . . . . .	8
VI	AMPLIFIER ADJUSTMENT . . . . .	9
VII	MECHANISM ADJUSTMENT . . . . .	15
VIII	TRANSPORT MECHANISM . . . . .	20
IX	MAINTENANCE PROCEDURES . . . . .	33
X	TROUBLE SHOOTING CHART . . . . .	34
XI	REPLACEMENT PARTS TABLE . . . . .	38
XII	SCHEMATIC DIAGRAM NUMBER CLASSIFICATION . . . . .	74
XIII	SCHEMATIC DIAGRAM	

# I. SPECIFICATIONS

POWER SUPPLY : AC 100 to 240 V, 50 or 60 Hz

RECORDING SYSTEM : In-line 4-track stereo, monaural recording by using Cross-field Bias Head.

TAPE SPEED : 1-7/8, 3-3/4, 7-1/2 and 15 ips.

TAPE SPEED DEVIATION : Within  $\pm 0.5\%$  at 7-1/2 ips  
Within  $\pm 1.0\%$  at 3-3/4 ips  
Within  $\pm 1.0\%$  at 1-7/8 ips

WOW AND FLUTTER : Less than 0.10% r.m.s. at 7-1/2 ips  
Less than 0.13% r.m.s. at 3-3/4 ips  
Less than 0.25% r.m.s. at 1-7/8 ips

FREQUENCY RESPONSE : 30 to 21,000 Hz  $\pm 3$  dB at 7-1/2 ips  
30 to 18,000 Hz  $\pm 3$  dB at 3-3/4 ips  
40 to 9,000 Hz  $\pm 4$  dB at 1-7/8 ips

SIGNAL TO NOISE RATIO (at Line Output) : Greater than 48 dB at 7-1/2 ips  
Greater than 45 dB at 3-3/4 ips  
Greater than 48 dB at 1-7/8 ips

TOTAL HARMONIC DISTORTION (at Line Output, 1,000 Hz 0 VU Rec/PB) : Within 1.7% at 7-1/2 ips  
Within 3.0% at 3-3/4 ips  
Within 3.0% at 1-7/8 ips

RECORDING INPUTS

MICROPHONE : Above 0.7 mV

LINE INPUT : Above 70 mV  
Impedance . . . 166 K ohms

DIN INPUT : High : 70 mV 166 K ohms  
Low : 7 mV 16 K ohms

OUTPUTS

LINE OUTPUT : Required Load Impedance : more than 50,000 ohms  
1.23 V (+4 db  $\pm 1.5$  db) at 7-1/2 ips  
1.03 V (+2.5 db  $\pm 1.5$  db) at 3-3/4 ips  
0.82 V (+0.5 db  $\pm 1.5$  db) at 1-7/8 ips

POWER OUTPUT: External Speaker Jack  
More than 10 W at 8 ohms Non-inductive resistance

NOISE : Less than 5 mV at 8 ohms at External Speaker Jack  
(Volume Control at "Minimum" position)

FAST FORWARD AND REWIND TIME : 75 seconds for a full 1,200 foot tape at 50 Hz  
60 seconds for a full 1,200 foot tape at 60 Hz

CROSS-TALK : Less than -70 dB (Monaural)  
Less than -43 dB (Stereo)

ERASE RATIO : More than 70 dB

INSULATION DURABILITY : 500 V AC for more than one minute duration

BIAS FREQUENCY: 100 KHz

MAIN MOTOR : Hysteresis Synchronous 3 speeds (2-4-8 pole) motor.  
Condenser Capacity 3  $\mu$ F (50 Hz), 2  $\mu$ F (60 Hz)  
Revolutions :  
3,000-1,500-750 r.p.m. (50 Hz)  
3,600-1,800-900 r.p.m. (60 Hz)

REEL MOTOR : Two 6-pole eddy current outer-rotor motors  
Revolutions :  
930 r.p.m. at 50 Hz, 100 V  
1,120 r.p.m. at 60 Hz, 120 V

HEADS

PLAYBACK HEAD : In-line 4-track stereo and monaural  
Impedance . . . 5,000 ohms at 1,000 Hz  
Gap . . . 2 microns

RECORDING HEAD : In-line 4-track stereo and monaural  
Impedance . . . 45 ohms at 1,000 Hz  
Gap . . . 2 microns

ERASE HEAD : In-line 4-track stereo and monaural  
Impedance . . . 380 ohms at 100 KHz  
Gap . . . 0.4 mm

CROSS-FIELD BIAS HEAD : In-line 4-track stereo and monaural  
Impedance . . . 430 ohms at 100 KHz  
Gap . . . 0.4 mm

INTERNAL SPEAKERS : 2 4-inch Round Speakers  
Nominal Power Input . . . 3 W, 16 ohms

TRANSISTORS USED : 15 2SC458LG (B)/(C)  
15 2SC372  
1 2SC828 (J)  
3 2SC538A (Q)  
2 2SC650 (B)  
1 2SC728  
1 2SB75A  
1 2SB77A (B)  
4 2SD157  
1 2SD147  
6 2SC828R  
2 2SC538RQ  
4 2SC696EB  
4 2SD130R  
9 IN34A  
2 10D2  
12 10D4  
1 10D6  
1 5B2  
2 SL-150  
2 SL-150d  
2 IN759A  
1 RD-24A

X-360D (without Main Amplifier) 44 ea.

Main Amplifier 16 ea.

## II. MEASURING METHOD

### TAPE SPEED DEVIATION

1. Method involving use of pre-recorded tape.

Playback on the tape recorder to be tested tape pre-recorded at  $1,000 \text{ Hz} \pm 0.1\%$  for measuring tape speed deviation. Connect the appropriate output to a frequency counter meter in order to measure the tape speed deviation from the resulting deviation of the measured frequency.

2. Method involving use of timing tape  
(designed for tape speed measurement)

This method utilizes a timing tape marked at intervals of  $7\text{-}1/2''$ . The running time of the tape over 60 marked section is measured in order to calculate the deviation of the tape speed. In applying this method, however, it should be born in mind that the timing tape stretch or contract, measurement error is inevitable, so that it is necessary to measure the total length of the tape in advance.

### WOW AND FLUTTER

Playback the 3,000 Hz pre-recorded tape whose wow and flutter level is guaranteed to be smaller than 0.07% for measurement by means of a wow meter. It is also possible for a 3,000 Hz sine wave to be recorded and played for measurement by means of the wow meter. In this case, however, the wow meter indicates a value as much as twice the value given in the specifications on the first page.

### FREQUENCY RESPONSE

#### RECORD:

- 1) Give a sine wave of 1,000 Hz to the Line Input of the recorder to be tested through an attenuator from an audio frequency generator.
- 2) Push the "Source Button" and adjust the line input volume so that the VU meter needle indicates "0" VU.
- 3) Under the condition described in (2), lower the input level 20 db by means of the attenuator.
- 4) Connect a microphone to the Microphone Input. Push the tape speed selector in  $7\text{-}1/2''$  position.
- 5) Start recording. Control the microphone input level and the spot frequency in the range of 30 Hz to 25,000 Hz from the audio frequency generator and record by talking.

\* Remarks: After announcing the frequency of each point, the the microphone volume should immediately be rotated back to minimum.

#### PLAYBACK:

- 6) Push the "Tape Monitor Button" and "Forward Button".
- 7) Set the Tape Speed Selector in  $7\text{-}1/2''$  position.
- 8) Connect a Vacuum Tube Volt Meter to the line output jack (V.T.V.M. with milli volt scale).
- 9) Playback the recorded tape.
- 10) Playback the recorded spot frequencies and make a memo of output level and plot the value on a graph.

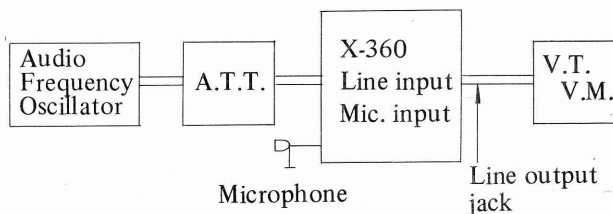

### TOTAL HARMONIC DISTORTION FACTOR

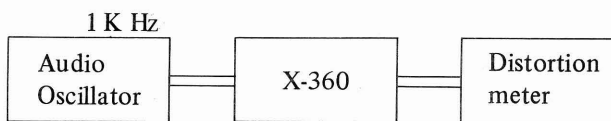

Connect the measuring instrument as shown above, and record the 1,000 Hz sine wave at "0" VU. Playback the resultant signal and measure the overall distortion factor. Measure the noise level of the tape recorder with the tape removed; connect the audio oscillator directly to the distortion meter for measurement of the distortion factor of the oscillator.

The required distortion factor may be obtained from the results of the above measurement by the following formula:

$$d_0 = d - d_1 - d_2$$

where,  $d_0$  = Required  
 $d$  = Overall distortion factor  
 $d_1$  = Noise level  
 $d_2$  = Distortion factor of the oscillator

(Note: New tape of particularly good quality should be used for measurement of the distortion factor).

### SIGNAL TO NOISE RATIO

Set the tone Switch on "Flat" position and Playback a tape containing a 1,000 Hz sine wave recorded at "0" VU level on a standard recorder. Connect a high sensitivity V.T.V.M. to the line output jack and measure its output.

Then remove the tape and measure the noise level under the same conditions. Convert into decibels each of the measured values.

## POWER OUTPUT

Playback a tape containing a sine wave of 1,000 Hz recorded at 0 VU on a standard recorder. Measure the voltage at the output of the recorder to be tested when terminated with 8 ohms resistance.

Then use the following formula:

$$P = \frac{E^2}{R} \quad \left\{ \begin{array}{l} P = \text{Desired output (watts)} \\ E = \text{Measured voltage (R.M.S.)} \\ R = 8 \end{array} \right.$$

## CROSS TALK (Cross talk between the tracks)

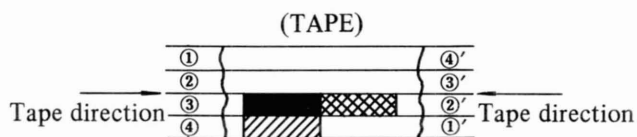

As shown in the figure, first record a 1,000 Hz sine wave on track No. 3 at + 3 VU level. Next, remove the 1,000 Hz input signal and record under a non-input condition. Then, playback the tape on track No. 3 and No. 1 (reversed condition of tape) through the 1,000 Hz B.P.F. (Band Pass Filter, Sensitivity . . . 1:1) and obtain a ratio between the two from the following formula.

$$C = 20 \log \frac{E_0}{E_2 - E_1} \text{ (db)}$$

C = Desired cross talk ratio (db)

$E_0$  = 1,000 Hz signal output level

$E_2$  = 1,000 Hz cross talk output level

$E_1$  = Non-input signal record level



### III. LOCATION OF CONTROLS

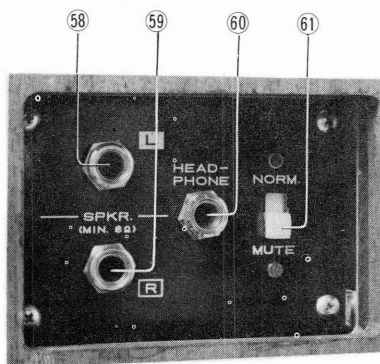
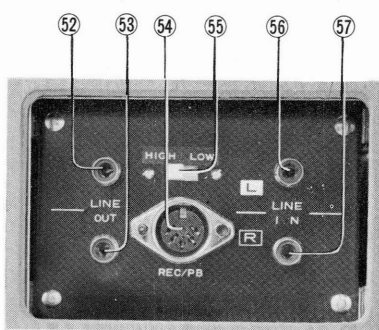
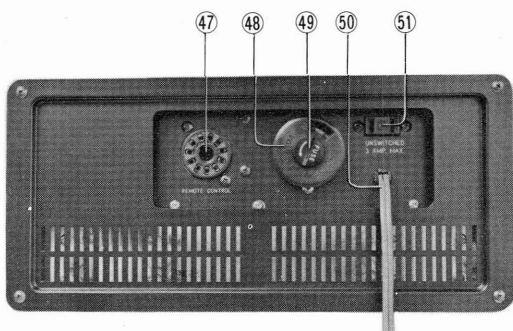
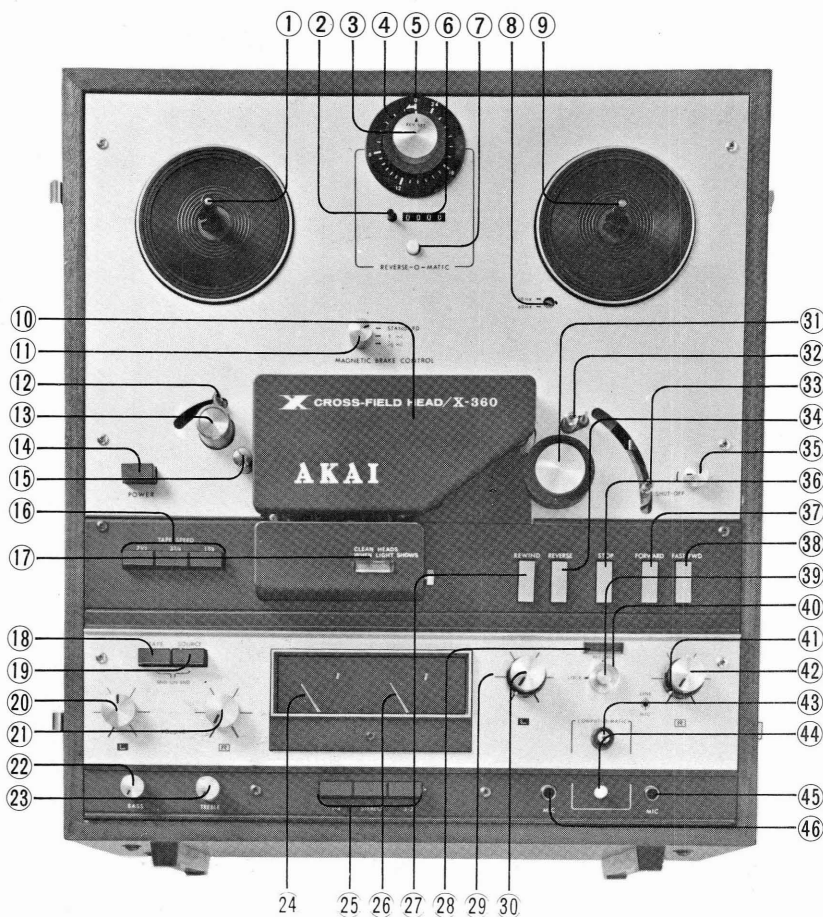

- ① Supply Reel Shaft
- ② Reset Button
- ③ Set Dial
- ④ Tape Count Meter
- ⑤ Tape Count Scale
- ⑥ Tape Counter
- ⑦ REVERSE-O-MATIC Set Button
- ⑧ Cycle Change Switch
- ⑨ Take-up Reel Shaft
- ⑩ Head Cover
- ⑪ Brake Control
- ⑫ Tension Arm
- ⑬ Impedance Roller
- ⑭ Power Switch
- ⑮ Tape Cleaner
- ⑯ Tape Speed Selectors
- ⑰ Indicator Lamp of Dust Minder
- ⑱ "TAPE" Button
- ⑲ "SOURCE" Button
- ⑳ Volume Control (Left)
- ㉑ Volume Control (Right)
- ㉒ Bass Control
- ㉓ Treble Control
- ㉔ VU Meter (Left)
- ㉕ Track Selectors
- ㉖ VU Meter (Right)
- ㉗ Rewind Button
- ㉘ Record Indicator Lamp
- ㉙ Line Record Level Control (Left)
- ㉚ Microphone Record Level Control (Left)
- ㉛ Pinch Wheel (Roller)
- ㉜ Reverse Pins
- ㉝ Take-up Tension Arm
- ㉞ Reverse Button
- ㉟ Shut off Switch
- ㊱ Stop Button
- ㊲ Forward Button
- ㊳ Fast Forward Button
- ㊴ Record Interlock Button
- ㊵ Record Safety Lock
- ㊶ Line Record Level Control (Right)
- ㊷ Microphone Record Level Control (Right)
- ㊸ COMPUT-O-MATIC Record Level Indicator
- ㊹ COMPUT-O-MATIC Set Button
- ㊺ Microphone Jack (Right)
- ㊻ Microphone Jack (Left)
- ㊼ Remote Control Socket
- ㊽ Voltage Selector
- ㊾ Fuse Post
- ㊿ AC Cord
- 1 AC Outlet
- 2 Line Output Jack (Left)
- 3 Line Output Jack (Right)
- 4 DIN Jack
- 5 HIGH/LOW Change Switch
- 6 Line Input Jack (Left)
- 7 Line Input Jack (Right)
- 8 External Speaker Jack (Left)
- 9 External Speaker Jack (Right)
- 0 Stereo Headphone Jack
- 1 Speaker Switch

## IV. DISMANTLING OF TAPE TRANSPORT UNIT & AMPLIFIERS



1) Remove CONTROL KNOBS (Volume, Line Record Level, Microphone Record Level, Bass & Treble which are marked (A) to (H) ) with taking off their RETAINING SCREWS by using a Philips-head screw driver.



2) Remove RETAINING SCREWS (marked (a) to (f) ) by using a Philips-head screw driver and remove the AMPLIFIER COVER PANEL (A).

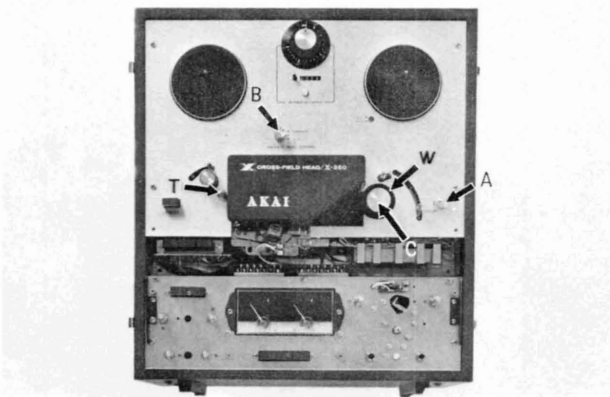

3) Remove KNOBS (BRAKE CONTROL & SHUT OFF SWITCH marked (A) and (B) ) with taking off the RETAINING SCREWS. PINCH WHEEL (W) is removed with taking off the PINCH WHEEL CAP (C) by hand. Remove TAPE CLEANER (T) by using minus head driver.

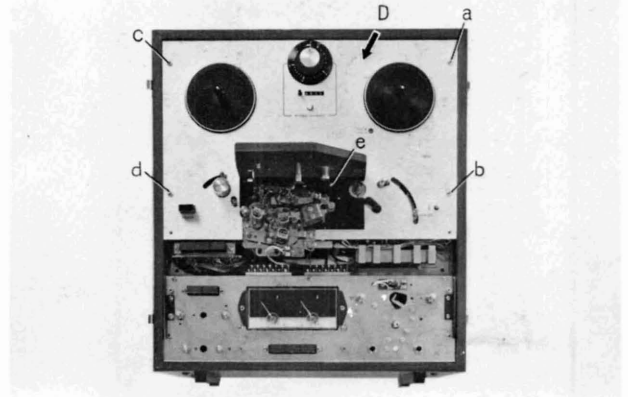

4) Remove SCREWS (marked (a) to (d) ) by using a Philips-head screw driver, and NUT (e) by using a box head driver, and remove the DECK COVER PANEL (D) along with MAIN HEAD COVER.



5) This picture shows all top cover panels removed making front mechanism control adjustment accessible.

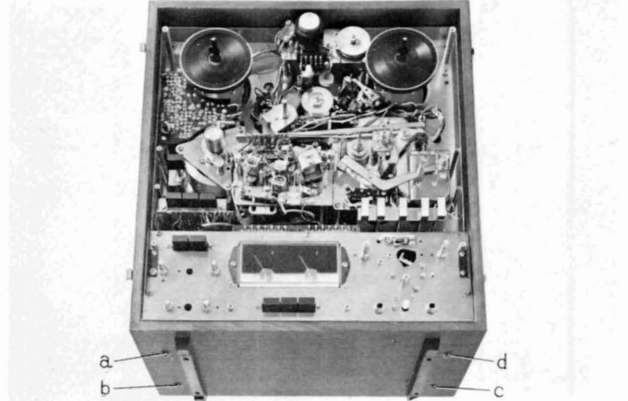

6) Remove RETAINING SCREWS (marked (a) to (d) ) by using a Philips-head screw driver.

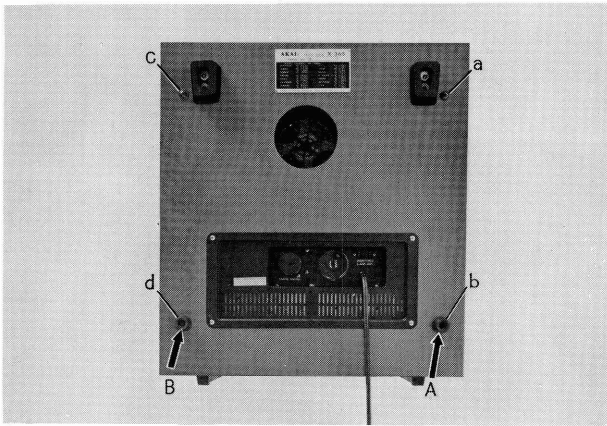

7) Remove RETAINING SCREWS (marked (a) to (d) ) by using a Philips-head screw driver and remove the RUBBER FEET (A) and (B).

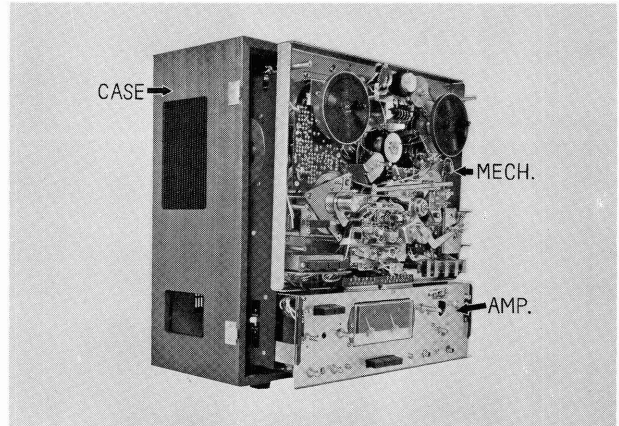

8) This picture shows all components removed from the case. The upper part houses the mechanism, the lower part the amplifiers.

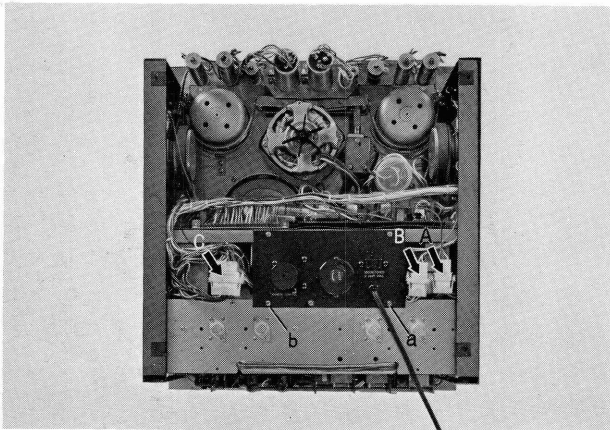

9) Carefully disconnect PLUGS (marked (A) to (C) ) and remove RETAINING SCREWS (marked (a) and (b) ).

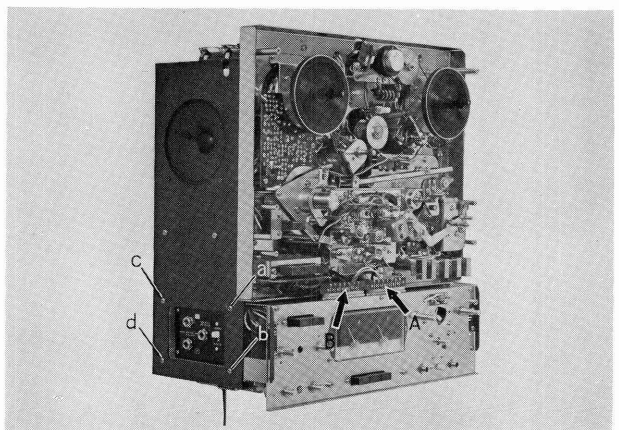

10) Carefully disconnect PLUGS (marked (A) and (B) ) and remove SELF TAPPING SCREWS (marked (a) to (d) ) by using a Philips-head screw driver.

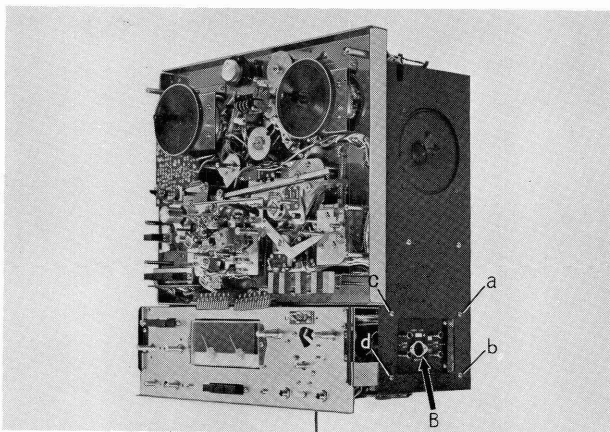

11) Remove SELF TAPPING SCREWS (marked (a) to (d) ) by using a Philips-head screw driver. The machine may then be separated into two parts.

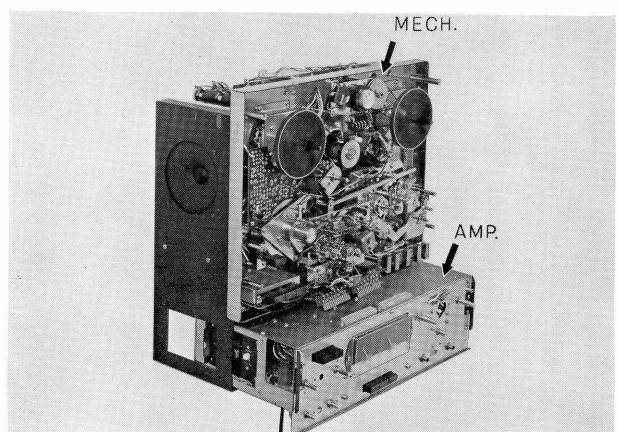

12) The amplifiers can now be removed.



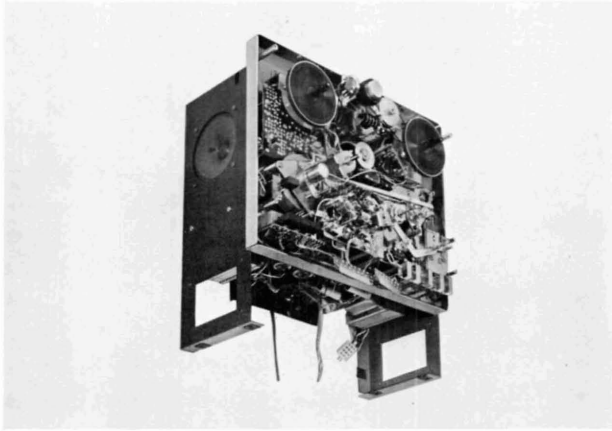

13) This picture shows the entire mechanical assembly. Any mechanical adjustment is now possible.

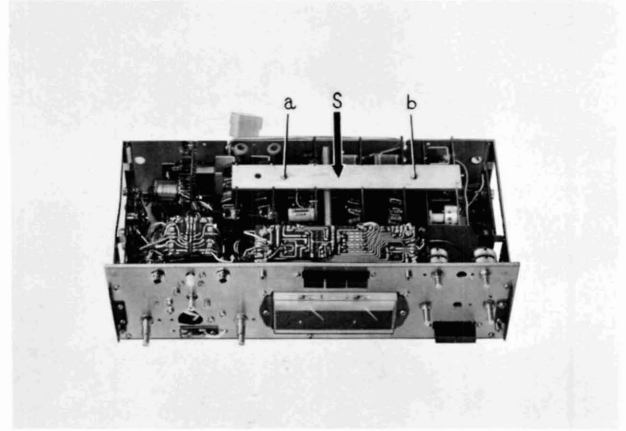

14) This picture shows the entire amplifier assembly, including PRE-AMPLIFIER & MAIN AMPLIFIER CARD BLOCKS. Remove RETAINING SCREWS ( a ) and ( b ) in order to remove the supporting plate ( S ).

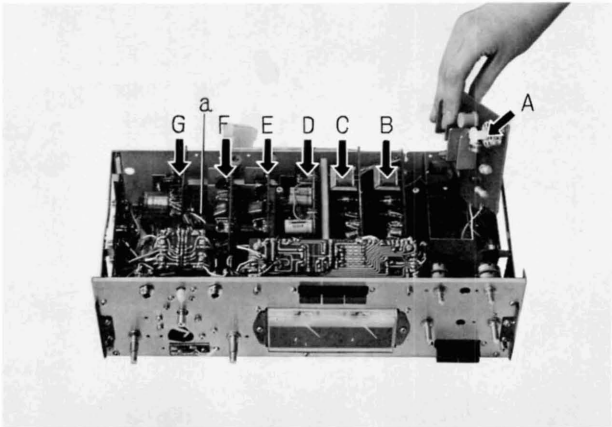

15) CARDS (marked from (A) to (F) ) are now available to be withdrawn. COM DETECTOR CARD BLOCK (G) will be withdrawn with removing screw (a) by using a Philips-head screw driver.

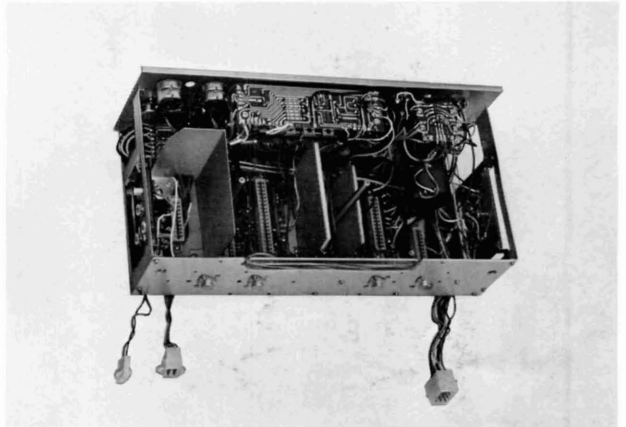

16) This picture shows the AMPLIFIER CHASSIS after all card blocks have been removed.

# V. MAGNETIC HEADS ADJUSTMENT

## 1. Adjustment of Magnetic Heads

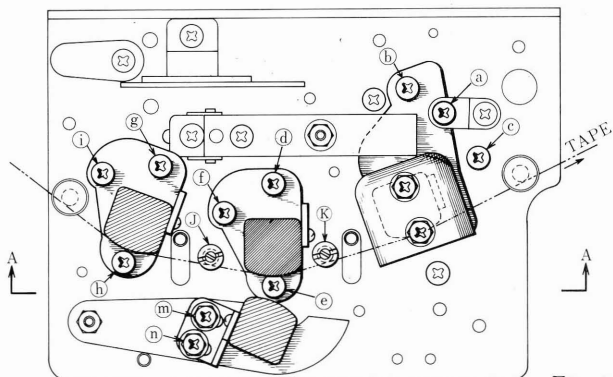

Fig. 1

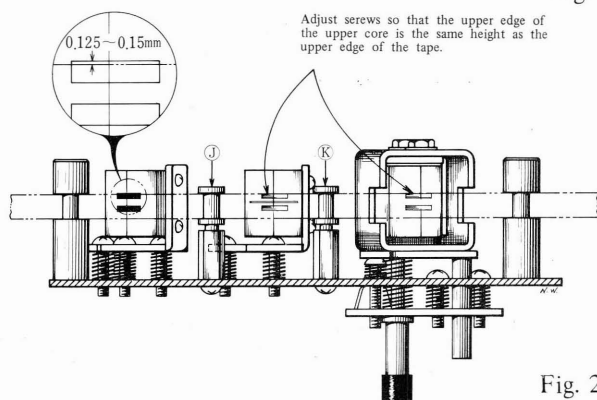

Fig. 2

the upper edge of the upper core is 0.125 to 0.15 mm higher than the upper edge of the tape. (Precaution)

In adjusting Head Height, make sure that the front of the Head is at right angles to the Chassis and that the upper and lower part of the Head firmly contact the tape.

### 1.2 Adjustment of Azimuth Alignment

#### 1) Playback Head

Use a Pre-recorded tape (16 KHz, 7-1/2 ips), and connect a highly sensitivity V.T.V.M. to the line output jack. Adjust Screw (C) (Figure 1) so that line output voltage is maximum.

#### 2) Recording Head

Connect an Audio Oscillator to the line input jack and record 16 KHz Signals at a -10db recording level and depress the Monitor "TAPE" Button. Adjust Screw (f) (Figure 1) so that the indicated V.T.V.M. value applied to the line output jack is maximum.

#### 3) Erasing Head

Visually check to assure that the centerline of the Erasing Head, is at right angles to the Head Chassis.

#### 4) Bias Head

Loosen Screws (m) and (n) (Figure 1), adjust angulation and clearance of the Bias and Recording Heads, as subsequently described in paragraph 2-5 (Adjustment of Recording Equalization (Balance) Characteristics).

Since adjustment of the Heads critically affects tape recorder performance, it is essential that Heads be carefully adjusted with precision measuring equipment and a suitable recorded tape.

### 1.1 Adjustment of Head Height (See Figures 1 and 2)

Whenever replacing the Head Assembly, adjust the Tape Guides (J) and (K) so that they do not contact the edge of the tape, then proceed with Head height adjustment.

#### 1) Playback Head

To adjust, turn Screw (a) (Figure 1) during "Normal Play" position so that the upper edge of the upper core of the Playback Head is the same height as the upper edge of the tape. Adjust by turning Screw (b) (Figure 1) during "Reverse Play" position so that the lower edge of the lower core of the Playback Head is the same height as the lower edge of the tape.

#### 2) Recording Head

Adjust with Screws (d), (e) and (f) (Figure 1) so that the upper edge of the upper core is the same height as the upper edge of the tape.

#### 3) Erasing Head

Adjust Screws (g), (h) and (i) (Figure 1) so that

## VI. AMPLIFIER ADJUSTMENT

### 1. PLAYBACK OUTPUT LEVEL (Pre-amplifier) ADJUSTMENT

- a) Connect a High-sensitivity V.T.V.M. to the Line Output Jack
- b) Set the Tape Speed Selector Switch to the "7-1/2" position.
- c) Playback a 250 Hz pre-recorded tape.
- d) Adjust the VR29-1 (semi-fixed resistor, 50 K-B) of the Pre-amplifier so that Line Output Voltage indicates 1.228 V (+4 dbm).

### 2. VU METER SENSITIVITY ADJUSTMENT

After the above adjustment, adjust the VR26-1 (semi-fixed resistor 2 K-B) of Chassis Print Board (RD-526) so that the VU meter needles indicate exactly 0 VU, denoted by dot.

### 3. MAIN AMPLIFIER ADJUSTMENT

- a) As shown in Fig. 1, connect the AM Meter (100 mA–150 mA scale) and a resistor ( $8\Omega$  20W) to the External Speaker Jack.
- b) Set the Main Amplifier Volume Control to minimum so that VR31-1 and VR31-2 (semi-fixed resistor 200 $\Omega$ -B) are wound counterclockwise.
- c) Set the Power Switch to the "ON" position. Adjust VR31-1 and VR31-2 so that the AM meter needle indicates "0".
- d) The foregoing should accomplish adjustment. In this condition Collector Voltage of 2SD130 (Power Output Transistor) should read 26 to 27 V, with Collector Current at 70 to 100 mA.

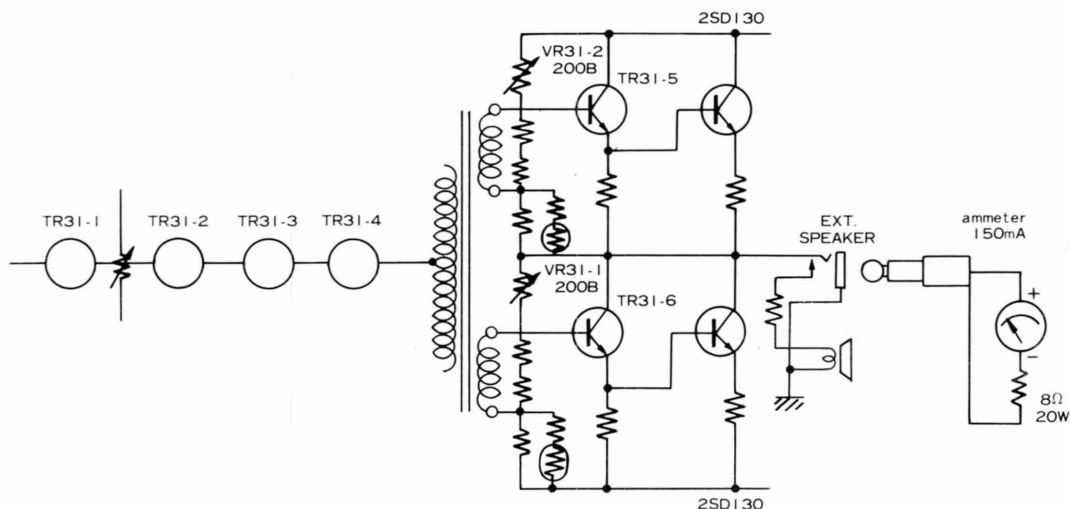

Fig. 1

#### 4. RECORDING AMPLIFIER ADJUSTMENT

Recording Amplifier Adjustment should be made only after Head Adjustment (vertical and horizontal azimuth) and Playback Amplifier Adjustments have been performed.

- Load a blank test tape (Scotch No. 150) on the Tape Recorder.
- As shown in Fig. 2, connect an Audio Oscillator and Attenuator to the Line Input. Connect a High-sensitivity V.T.V.M. to the Line Output.
- Set the Tape Speed Selector to "7-1/2" and the Monitor Switch to "TAPE" position.
- By using the Audio Oscillator, supply a 1,000 Hz signal. Set the tape to transport, and the Record Interlock Button to recording mode.
- Adjust the Line Level Control so that the VU meter needle indicates "0" (white dot).
- Set the Monitor Switch to "SOURCE" position. Adjust the VR28-1 (semi-fixed resistor, 20 K-B) of Recording Amplifier Board (RD-528) so that the VU meter needle indicates "0" (white dot).

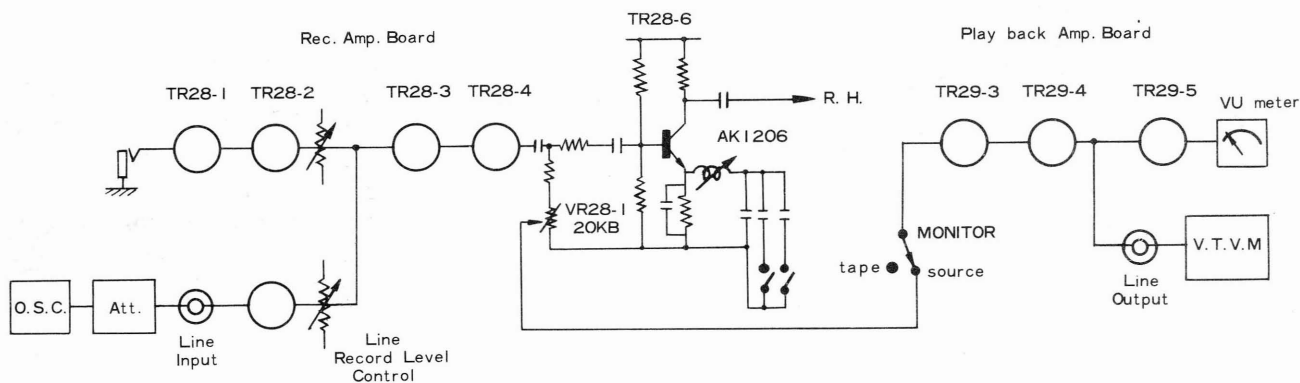

Fig. 2

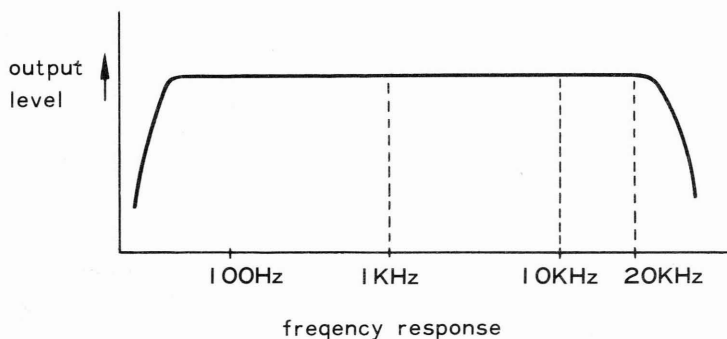

Fig. 3

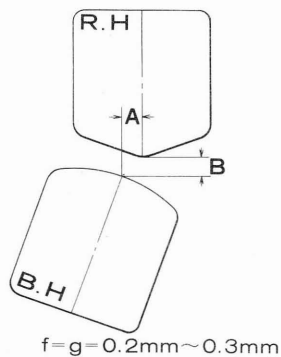

Fig. 4

## 5. RECORDING EQUALIZATION CHARACTERISTICS ADJUSTMENT

- For tape and meters, follow the procedure used for the adjustment of the recording amplifier.
- Adjust the Recording Level Control by setting the Monitor Switch to "SOURCE" position so that the VU meter needle indicates "0" (white dot).
- Attenuate the Audio Oscillator signal by 20 db.
- Start the tape, by pushing the Forward Button then press the Record Button to record. The Monitor Switch must be set to "TAPE" position.
- As shown in Fig. 3, increase the frequency of the Audio Frequency Oscillator by steps from 1 KHz to 10 KHz. Adjust Bias Voltage and Bias Head angle including the gap between Bias and Recording heads. The V.T.V.M. which is connected to the Line Output, should indicate the same voltage when using 1 KHz to 10 KHz.
- During 7-1/2" operation, the Bias Voltage may be adjusted by turning the white knob VR30-1 (semi-fixed resistor 2K-B) of Bias Oscillator Board (RD-530) clockwise.

This adjustment should begin when VR30-1 is fully wound in the clockwise position.

- As shown in Fig. 4, Gaps A and B, which are between the Recording and Bias Heads, should be about 0.2 mm.
- After completion of the foregoing, observe the Recording Playback Output Voltage at 1 KHz and 10 KHz. If this voltage remains constant, change the frequency response of Audio Oscillator continuously. Check to see that the Output Voltages are within  $\pm 3$  dB at any condition up to 20 KHz. If the response around 20 KHz reads more than  $\pm 3$  dB difference when compared with response at 10 KHz, adjust the Peaking Coil (AK1206) of the Recording Amplifier to match the High-range response.
- If the frequency response is gained as specified, reset the Attenuator Dial to read "0" VU. Follow the operation as detailed in 4 (e) & (f), and re-adjust the Recording Level of the Recording Amplifier to 0 VU at 1,000 Hz.

- Set the Tape Speed Selector to "3-3/4" and attenuate the Input signal to -20 dB. Adjust the VR30-2 (semi-fixed resistor 5 K-B) of Bias Oscillator Board (RD-530) so that the responses at 1 KHz and 10 KHz in Recording/Playback condition, are at the same level.
- After the same response at 1 KHz and 10 KHz has been gained, increase the Input signal to 18 KHz by steps. Check whether 18 KHz is within -6dB.
- Distortion level at 7-1/2" should be within 2% and 3% at "3-3/4".

## 6. DM DETECTOR SENSITIVITY ADJUSTMENT

- Before adjustment, remove the solder at point P (Time Delay circuit of 15 seconds) which is shown in Figs. 5 and 6.
- Turn the Microphone Record Level Control (left channel) slightly clockwise from the medium level position. Then, record the non-input signal for 15 seconds.
- Playback that signal. Adjust VR71-1 (semi-fixed resistor 10 K-B) of DM Detector Card so that DM indicator lamp is extinguished.
- Playback a new blank tape. Adjust VR71-1 so that the Indicator lamp lights.
- Check to see that the lamp is lighted when the tape is off the Playback Head during playback operation.
- Solder Point P as shown in Figs. 5 and 6. After soldering, the DM Indicator Lamp should light after 15 seconds following the stoppage of input signal to the DM Detector circuit.

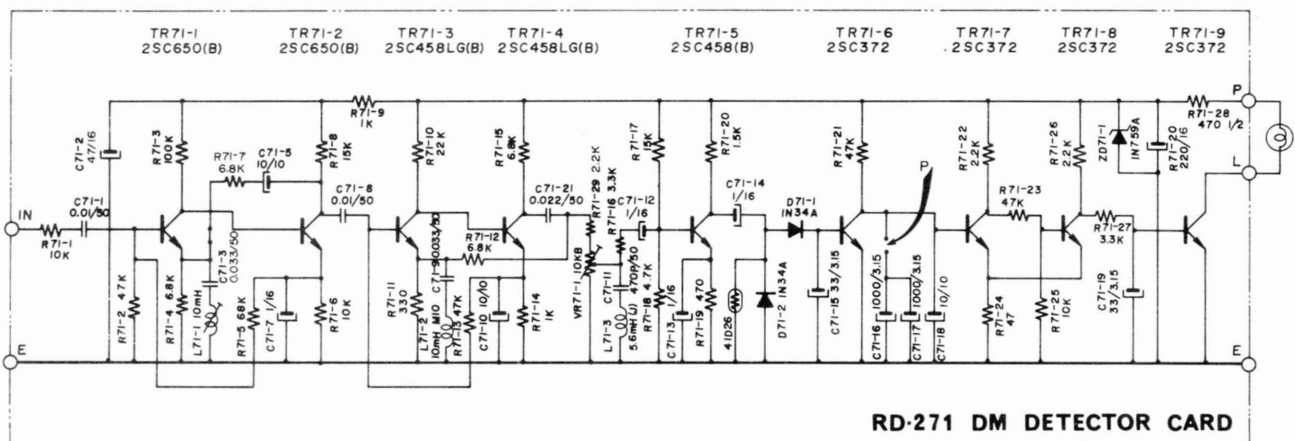

Fig. 5

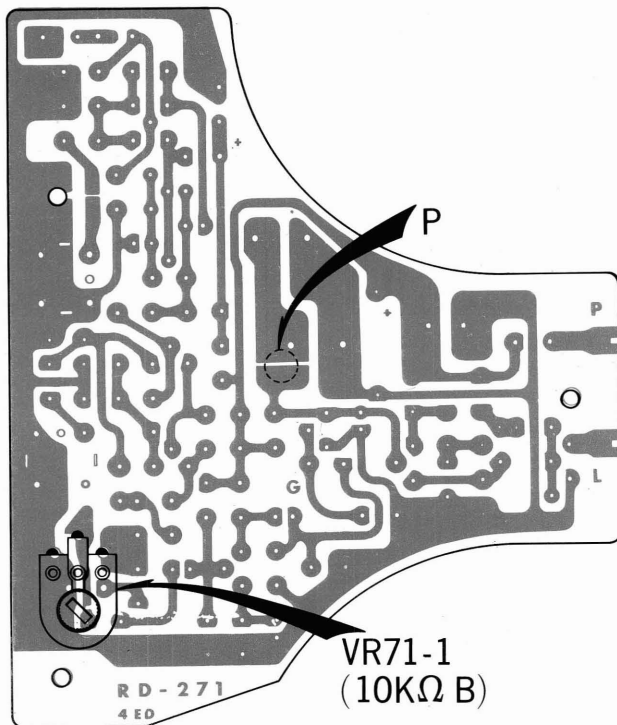

Fig. 6

## 7. ADJUSTMENT OF COMPUT-O-MATIC RECORDING LEVEL SENSITIVITY

- a) As shown in Fig. 7, connect an Audio Oscillator to the Left Line Input Jack (56) of the tape recorder, and supply a 1,000 Hz signal.
- b) Push the "SOURCE" Monitor Button. Set the Track Selector to "STEREO".
- c) Turn the Line Record Level Control Knob (19) so that the left channel VU meter needle indicates "O" VU (white mark). The COMPUT-O-MATIC should be set to the "OFF" position.
- d) Push the COMPUT-O-MATIC Button to the "ON" position, and the Indicator needle automatically moves from maximum to "O" VU level.
- e) Adjust the semi-fixed resistor VR70-1 (100KB) of COM DETECTOR CARD (RD-570) so that VU meter needle indicates exactly "O" VU.
- f) If the VU meter needle indicates lower than "O" VU, reset the COMPUT-O-MATIC Button to "OFF" position. Readjust the VR70-1 to an increased value, push the button to "ON" and recheck.

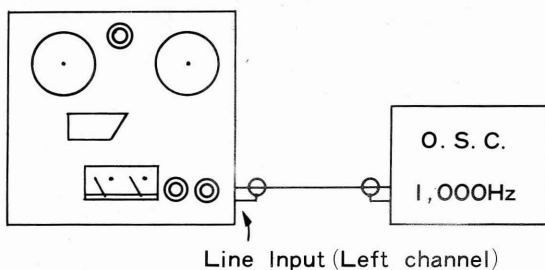

Fig. 7

## VII. MECHANISM ADJUSTMENT

### 6. Mechanism Adjustment

#### 6.1 Alignment of Capstan Drive Mechanism

The Capstan Drive Belt should run in the center of the Motor Pulley and Flywheel, as shown in Figure 1. To position the Capstan Drive Belt, with proper clearance between the Motor Mounting Plate and the Chassis use adjusting Screws (C) and (A), shown in Figure 2. After adjustment, tighten Lock Screws (B) and (D).

- 1) With Motor rotating in the Normal direction, loosen Screws (B) and (D) and adjust Belt position by turning Screw (C).
- 2) With Motor rotating in the Reverse direction, adjust Belt position by turning Screw (A). After Drive Belt position has been properly adjusted to run in the center of the Motor Pulley and Flywheel (according to direction of motor rotation), lock by tightening Screws (B) and (D).

- 3) With the Motor rotating and with the recorder switched from 50 to 60 Hz, verify that the Drive Belt does not contact the Belt Shift Lever.
- 4) If the Drive Belt contacts the Belt Shift Lever, loosen Screw (E), and move the Belt Shift Lever Stopper so that the Belt does not contact the Shift Lever.

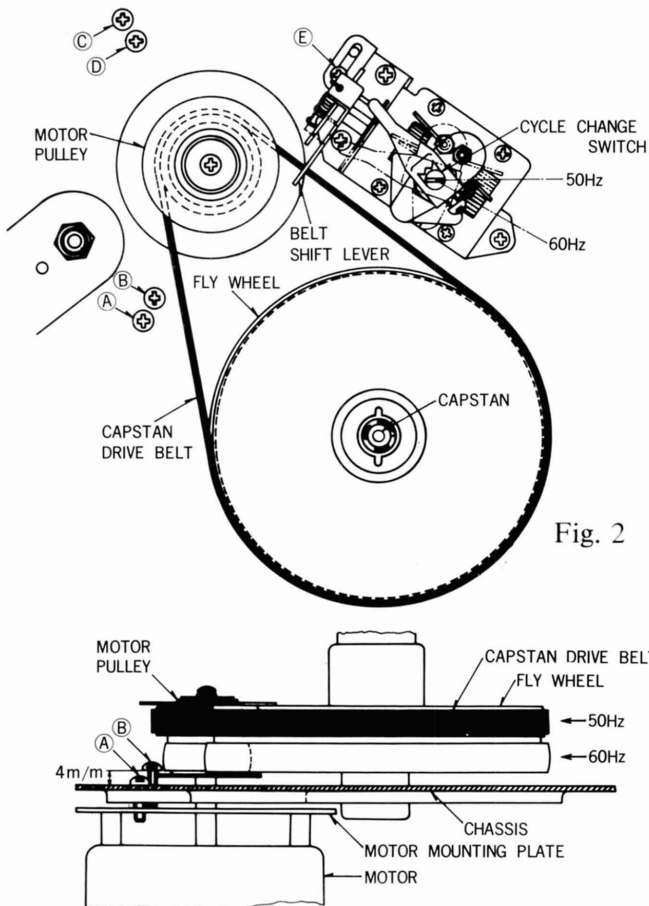

Fig. 1

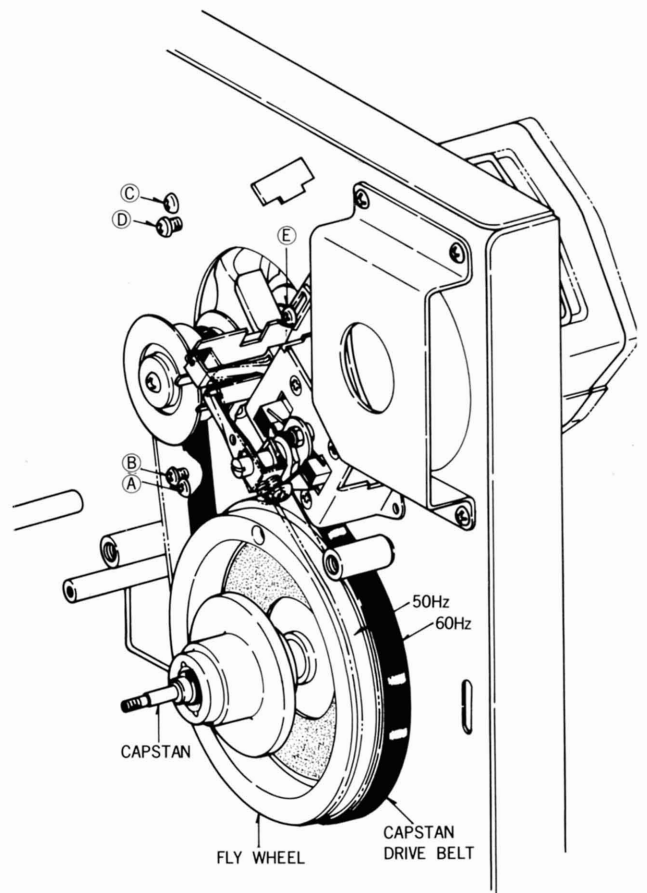

Fig. 1,2

2. Adjustment of Pinch Roller Mechanism

- 1) Pinch Roller Solenoid Position—Set the Solenoid so that there is approximately 0.3 mm clearance between the end of Plunger (b) and the bottom of the Solenoid when the Pinch Roller Shaft is depressed with your finger, and then tighten Screw (a). (See Figure 3a)
- 2) Pinch Roller Pressure—Apply a Tension Gauge to the Pinch Roller Shaft, and adjust Nut (C1) so that pressure is 1.8 kg/cm when set for Playback. Then tighten Nut (C2) and secure with Nut (C1).

- 3) Adjust Nut (e) so that there is approximately 0.5 mm clearance between Shifter Pin (d) and the upper edge of the hole in the Head Mounting Plate when set for Playback.
- 4) Set to Playback with the Pinch Roller contacting the Capstan and verify that the Tape Shifter Lever depresses Microswitch SW-210 and SW-211 Pins, as shown in Figure 3b, and make sure that switches operate correctly. To adjust positions of Microswitches SW-210 and SW-211, loosen Screws (f) and (g).

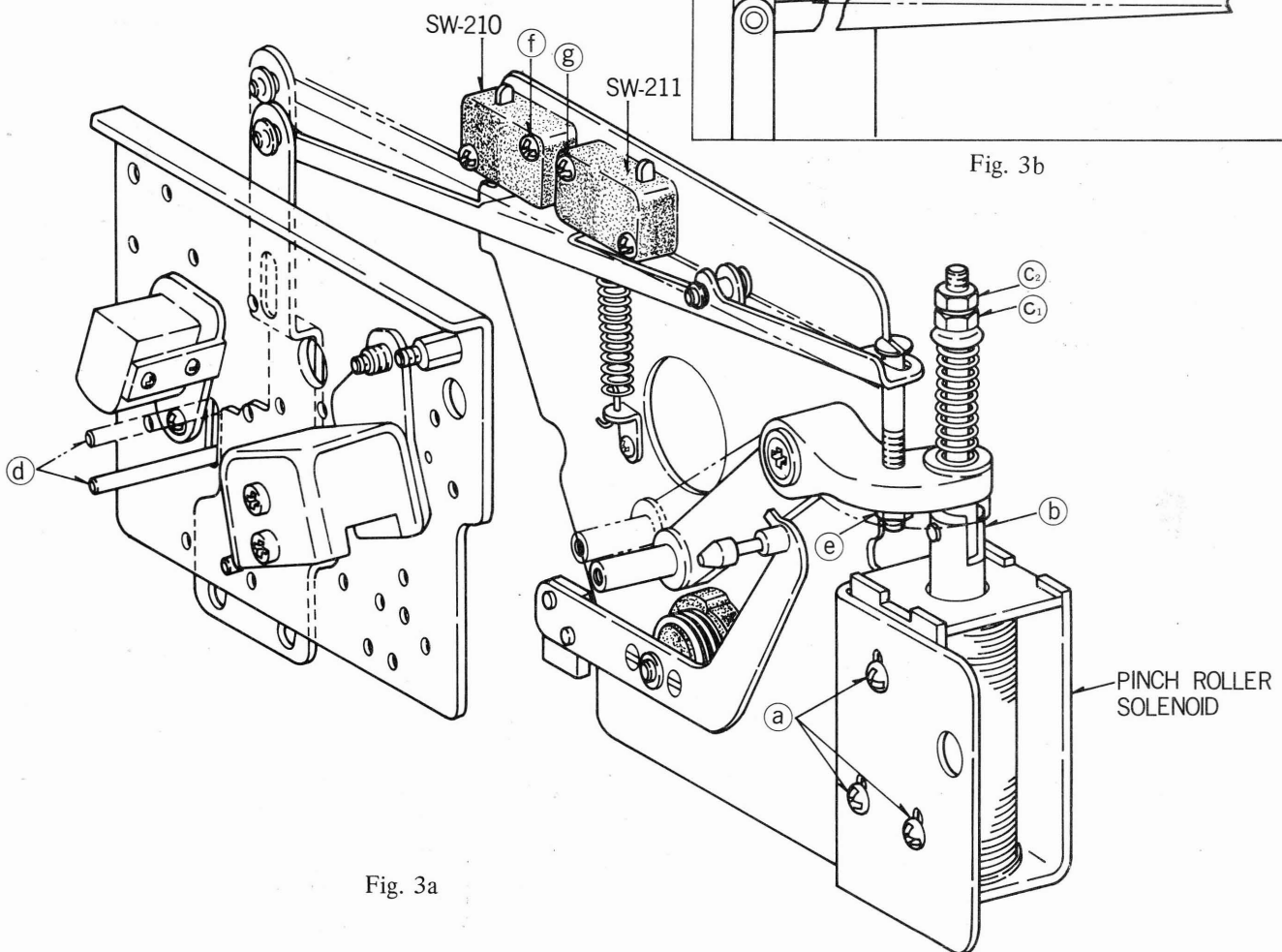

Fig. 3a

Fig. 3b



### 3. Adjustment Brake Mechanism

- 1) To adjust Brake Solenoid position, align the Left and Right Brake Levers when the Solenoid Plunger is retracted.
- 2) One end of the Brake Band is centered in the elliptical hole in the Brake Band, as shown by (a) (a') in Figure 4a.
- 3) For metal Brake Band Retainer, adjust Screw (b), so that the clearance between the Brake Band and motor circumference is uniform, as shown in Figure 4B.
- 4) Adjust the set position of the Brake Band Spring so that Brake tension is 150 grams (using 60 mm diameter tape and measuring with a Tension Gauge) (See Figure 4a (c) (c')).

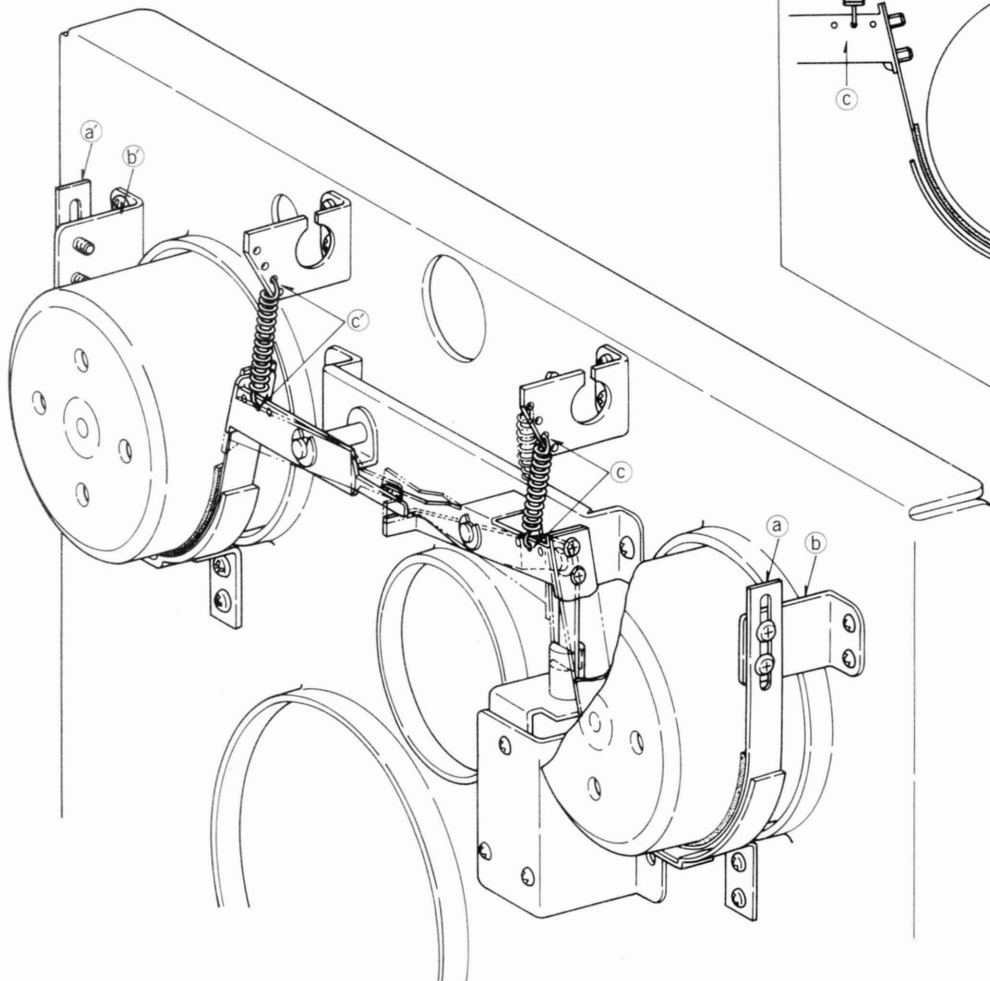

Fig. 4a

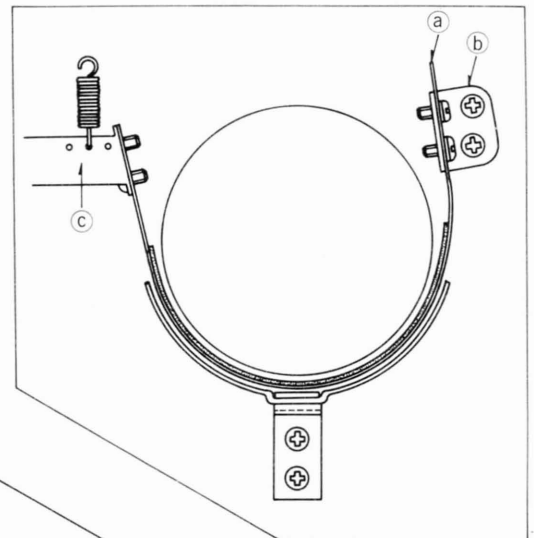

Fig. 4b

#### 4. Adjustment of Tape

For all measurements, use 60 mm diameter tape, and measure tape tension with a Tension Gauge.

Set the Magnetic Brake Control Switch to STANDARD.

- 1) Back tension for "Reverse Play" depends upon the torque of Motor B, as shown in Figure 6. Adjust back tension to 60 grams adjusting the 230  $\Omega$  Resistor (F), as shown in Figure 5. At this tension setting, voltage applied to Motor B is approximately 29 V.
- 2) Take-Up tension for "Normal Play" depends upon the torque of Motor B, as shown in Figure 6. Adjust take-up tension to 100 grams by adjusting the 120  $\Omega$  Resistor (A), as shown in Figure 5. At this tension setting, voltage applied to Motor B is approximately 41 V.

- 3) Back tension for "Normal Play" depends upon the torque of Motor A, as shown in Figure 6. Adjust back tension to 60 grams by adjusting the 230  $\Omega$  Resistor (F), as shown in Figure 5. At this tension setting, voltage applied to Motor A is approximately 29V.
- 4) Take-up tension for "Reverse Play" depends upon the torque of Motor A, as shown in Figure 6. Adjust Take-up tension to 220 grams by adjusting the 120  $\Omega$  Resistor (A), as shown in Figure 5. At this tension setting, voltage applied to Motor A is approximately 62V.

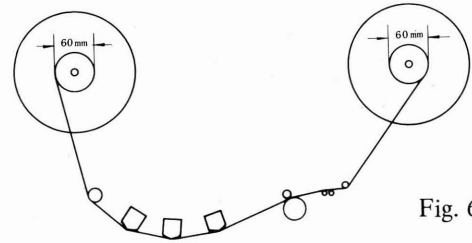

Fig. 6

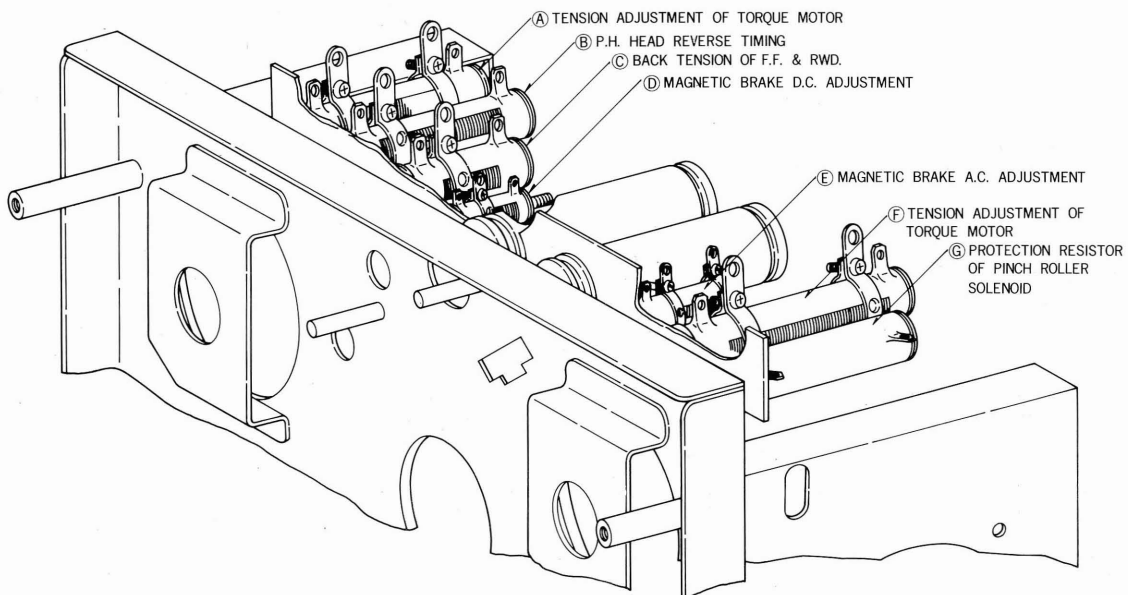
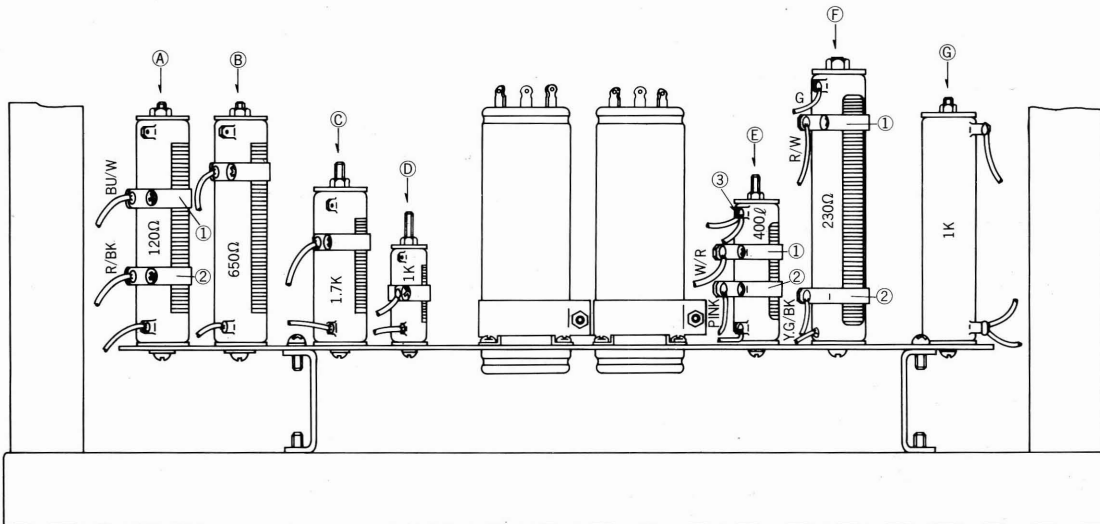

Fig. 5

---

5. Adjustment of Playback Head Reverse Timing

The Playback Head reproduces on Tracks 1-3 for "Normal Play" and on Tracks 2-4 for "Reverse Play" when using Stereo Tape.

The Playback Head lowers to Track 2-4 position, when switched from Normal to Reverse Play. If the Playback Head lowers with the tape contacting the Head, a loud noise will be heard from the speaker. The Tape Shifter releases the tape from contact with the Playback Head before the Head lowers.

Adjust the 650  $\Omega$  Resistor (B), as shown in Figure 5, so that 38 Volts is applied between the terminals (white and gray wire) (Reverse Head Solenoid Coil).

6. Adjustment of Magnetic Brake

1) Adjust the 400  $\Omega$  Resistor (E) (in Figure 5) so that the terminals on each end of the Resistor are equidistant.

2) Center the Slider of the 1K  $\Omega$  Resistor (D), as shown in Figure 5. (D.C. Brake)

3) Set the Magnetic Brake Control Switch to STANDARD. Depress the STOP Button near the outer end of a 7" reel of tape at FAST FORWARD to determine whether the tape turns in the rewind direction.

4) If the tape turns in the rewind direction, increase D.C. Brake voltage by adjusting the Slider (1) of the 1K  $\Omega$  Resistor (D) to decrease resistance or adjust slider (1) toward terminal (3) of the 400  $\Omega$  Resistor (E), as shown in Figure 5. Also verify that Brake Band tension is accurately adjusted to 150 grams.

5) Set the Magnetic Brake Control Switch to 1.0 or 0.5 mil and check the following: FAST FORWARD  $\rightarrow$  STOP, REWIND  $\rightarrow$  STOP. If the tape loses its tension and becomes slack at STOP, move the Slider (2) of 400  $\Omega$  Resistor (E) toward Slider (1), as shown in Figure 5.

After the foregoing adjustments, verify (with the Magnetic Brake operating) that torque motor tension is as follows:

Standard : approx. 300 ~ 330 gram.  
1.0 or 1/2 mil : approx. 250 gram.

7. Adjustment of Back Tension for FAST FORWARD and REWIND.

1) Adjust the slider of the 1.7 K $\Omega$  Resistor (C), shown in Figure 5, so that overall resistance is 1.3 K $\Omega$ . If Resistor (C) itself is 1.3 K $\Omega$ , no adjustment is required.

8. Adjustment of Reel Table Height

To adjust Reel height, loosen the two screws on the bottom of the Reel Table and adjust so that height from the Chassis to the upper edge of the Reel Table is 53.5 mm.

## VIII. TRANSPORT MECHANISM

---

Explanation of Relays and Solenoids included in X-360.

- REC 2 : Recording Relay 2  
Actuated by REC Relay 1.  
Switches Recording Head to ON/OFF.
- RT : Reverse Timing Relay  
Charges at 220  $\mu$  when changing from  
Reverse to Normal operation.
- REV H : Head Reverse Solenoid  
Depresses Playback Head to Reverse  
position in the reverse mode.
- REV 1 : Reverse Relay 1  
Reverses motor rotation. Locks Reverse  
circuit. Controls PLY Relay.
- REV 2 : Reverse Relay 2  
Switches the Reel Motor Tension  
during Reverse operation.
- REV 3 : Reverse Relay 3  
Switches the Playback Head connection  
(L.ch. R.ch.) during Reverse operation.
- PT : Pinch Roller Timing  
Stops tape in 4 seconds while changing  
Normal and Reverse.
- PLY : Play Relay  
Locks BRK., QT., PR. control & PLY  
circuit.
- PR : Pinch Roller Solenoid
- REC 1 : Recording Relay 1  
Locks REC Relay 2 control and  
Recording circuit.
- BIAS : Bias Head Control Solenoid
- QT : Quick Tension  
Used under all operations and at starting  
time, operates to provide Reel. Motor a  
high force.
- BRK : Brake Solenoid
- MAG : Magnetic Brake Relay  
Constantly ON during normal operation.  
In Off position Magnetic Brake circuit  
operates.
- TIM : Time Constant Relay  
ON during Fast Forward and Rewind  
operations. Controls Magnetic Brake  
operation.
- RWD : Rewind Relay
- FF : Fast Forward
- DS : Direction Switch Relay  
Operates only during Rewind mode.  
Controls the direction of the Magnetic  
Brake operation.
- SENS : Sensing Relay  
Operated by Sensing Tape or Reverse  
Dial. Also sets Reverse circuit to ON.

# SYSTEM CONTROL BOARD (RD-144) BLOCK DIAGRAM

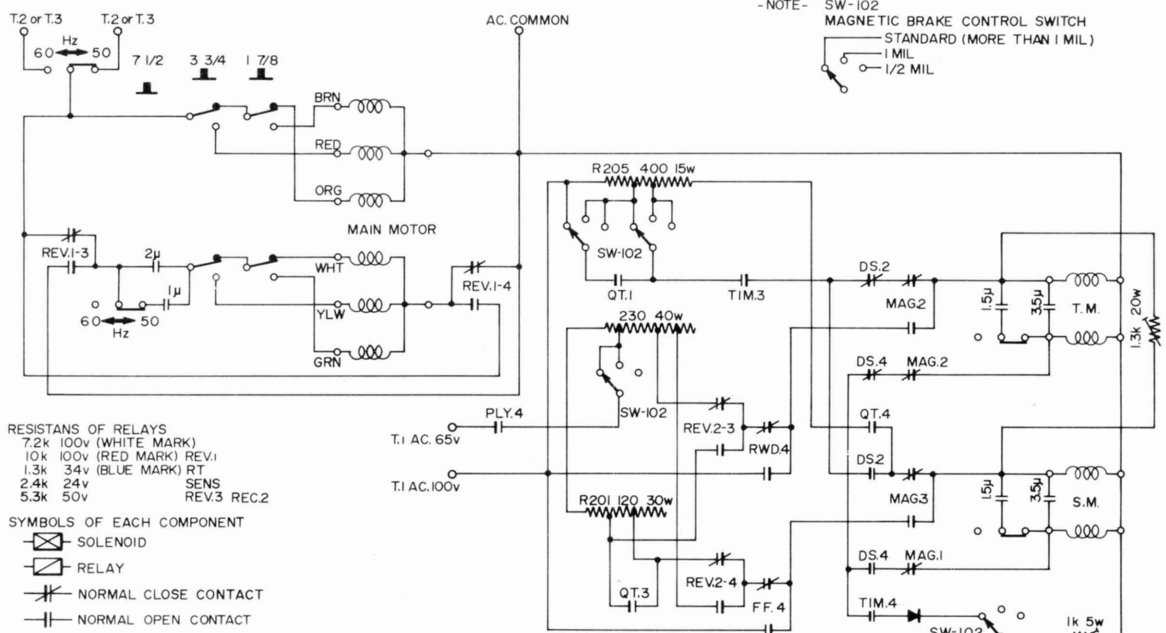
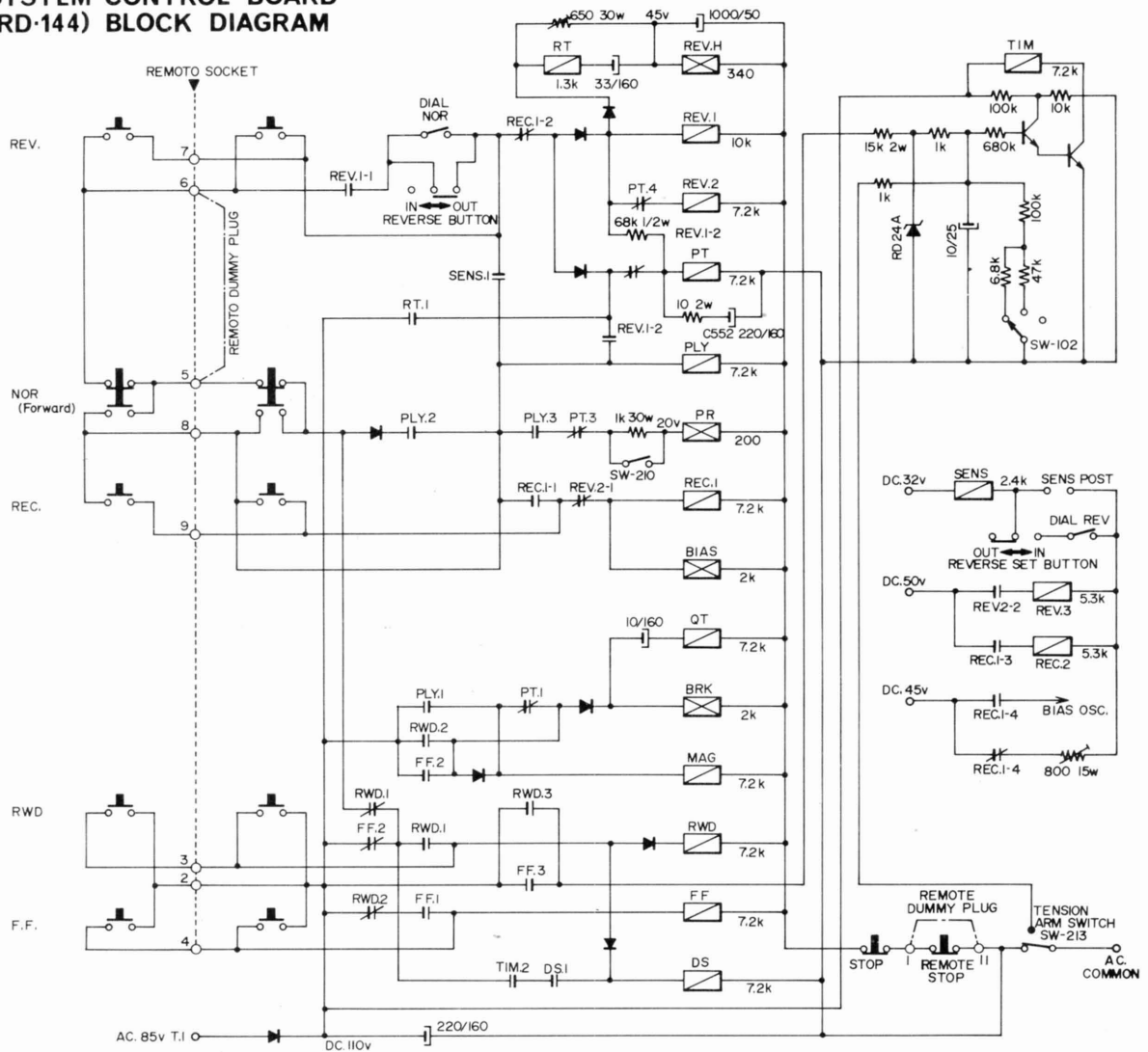

- RESISTANS OF RELAYS  
 7.2k 100v (WHITE MARK)  
 10k 100v (RED MARK) REV.1  
 1.3k 34v (BLUE MARK) RT  
 2.4k 24v SENS  
 5.3k 50v REV.3 REC.2
- SYMBOLS OF EACH COMPONENT  
 [Solenoid Symbol] SOLENOID  
 [Relay Symbol] RELAY  
 [Normal Close Contact Symbol] NORMAL CLOSE CONTACT  
 [Normal Open Contact Symbol] NORMAL OPEN CONTACT

- NOTE - SW-102  
 MAGNETIC BRAKE CONTROL SWITCH  
 STANDARD (MORE THAN 1 MIL)  
 1 MIL  
 1/2 MIL

## 1. Relays & Solenoids Actuated for Each Operation

Function	R.T.	REV1	REV2	REV3	P.T.	PLY	REC1	REC2	SENS	Q.T	MAG.	RWD.	F.F.	DS	TIM.	Solenoid			
																REV.H	PR	BIAS	BRK
Normal Play						○				○	○							○	
Reverse Play	○	○	○	○	○	○			○	○	○					○	○		○
Recording						○	○	○		○	○							○	○
Fast Forward										○	○		○		○				○
Rewind										○	○	○		○	○				○

○ mark indicates "engaged".

Fig. 1

### 2. STOP

Load a tape and depress the Power Switch. Current flows as indicated by the red line in Figure 2, driving the Main Motor in the normal direction, and lights the VU Meter Lamp.

### 3. PLAY

With the Recorder set to STOP, depress the FORWARD Button. Current flows as indicated in Figure 3, actuating the PLY, QT, and MAG Relays and the P.R. and BRK Solenoids. Tape is fed in the normal (forward) direction at a constant speed as current is supplied through R201 and R206 to Left and Right Reel Motors. To provide increased starting torque for the Reel Motors, the QT Relay is actuated approximately 0.2 second after the FORWARD Button is depressed, partially shorting R201 and applying higher voltage to the Take-up Motor. The Block Diagram clearly show the operation of the individual relays.

### 4. FAST FORWARD

When the FAST FORWARD Button is depressed, current flows as indicated in Figure 4, actuating the FF, MAG, QT, and TIM Relays and the BRK Solenoid. 100V is supplied to the Take-up Motor, and 13V is fed to the Supply Motor through R203, for back tension application during FAST FORWARD feed.

### 5. REWIND

When the REWIND Button is depressed, current flows as indicated in Figure 5, actuating the RWD, QT, MAG, DS, and TIM Relays and the BRK Solenoid. 100V is supplied to the Supply Motor and 13V is fed to the Take-up Motor through R203, for back tension application during REWIND.

### 6. Magnetic Brake

When the STOP Button is depressed during FAST FORWARD or REWIND, the Magnetic Brake smoothly and quickly stops the fast moving tape.

a) When the STOP Button is depressed during REWIND, Condenser C44-7 (10  $\mu$ F) is discharged through VR44-1 (100K  $\Omega$ ) and R44-4 (6.8K  $\Omega$ ), as shown in Figure 6.

Discharge Time Constant is 2 seconds with SW102 set to STANDARD, or 4 seconds when set to 1 or 1/2 mil. During discharge Tr44-1 (2SC372) and Tr44-2(2SC728), as well as TIM and DS Relays remain engaged. 65V AC is supplied to the Take-up Motor through R205 (400  $\Omega$ ) and DC current is supplied to the Take-up Motor Sub Coil through R205(1K  $\Omega$ ) and Diode (10D4), allowing the Take-up Motor to serve as a Brake.

b) When the STOP Button is depressed during FAST FORWARD, the TIM Relay remains engaged, and supplies both AC and DC to the Supply Motor which serves as a Brake for the fast moving tape. When the Magnetic Brake Control Switch SW-102 is set to 1 or 1/2 mil, D44-11 and R204 are cut out from the circuit and AC only is supplied to the Motor.

Because the Brake Band only assists the Magnetic Brake, Brake Tension (Braking Power) applied by the Brake Band can be of a comparatively smaller value than usual.

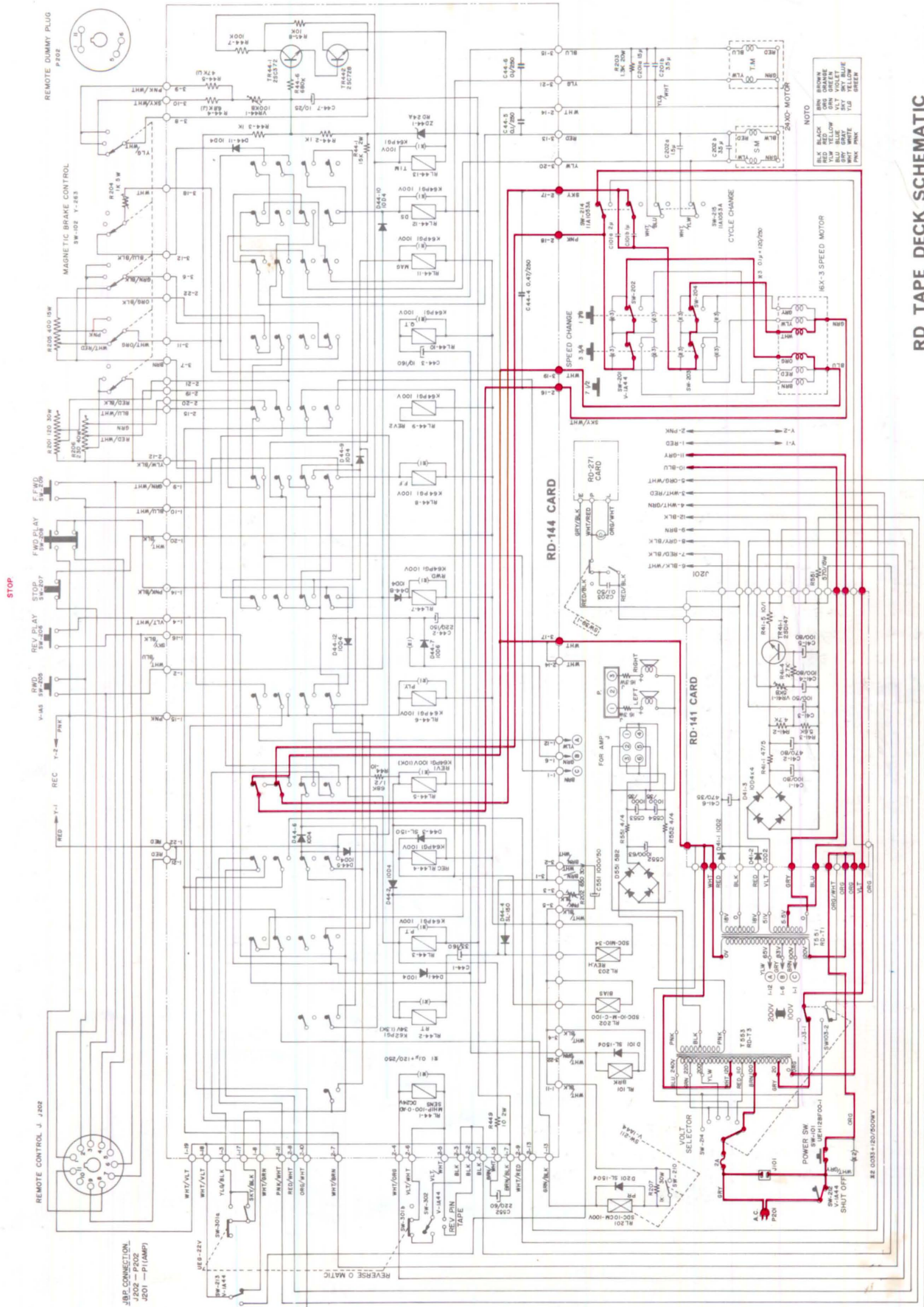

RD TAPE DECK SCHEMATIC

Fig. 2





# FAST FORWARD

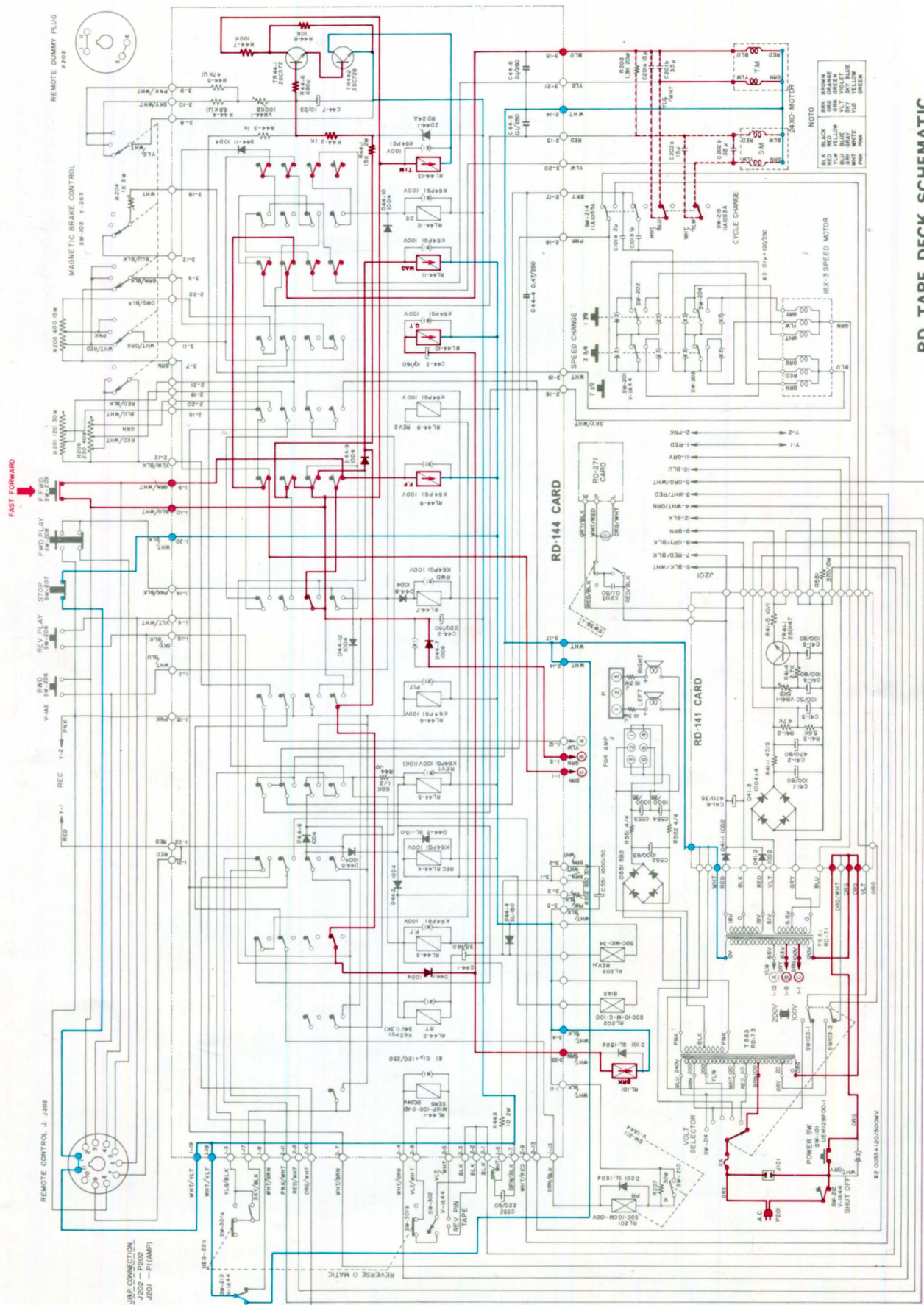

RD TAPE DECK SCHEMATIC

Fig. 4

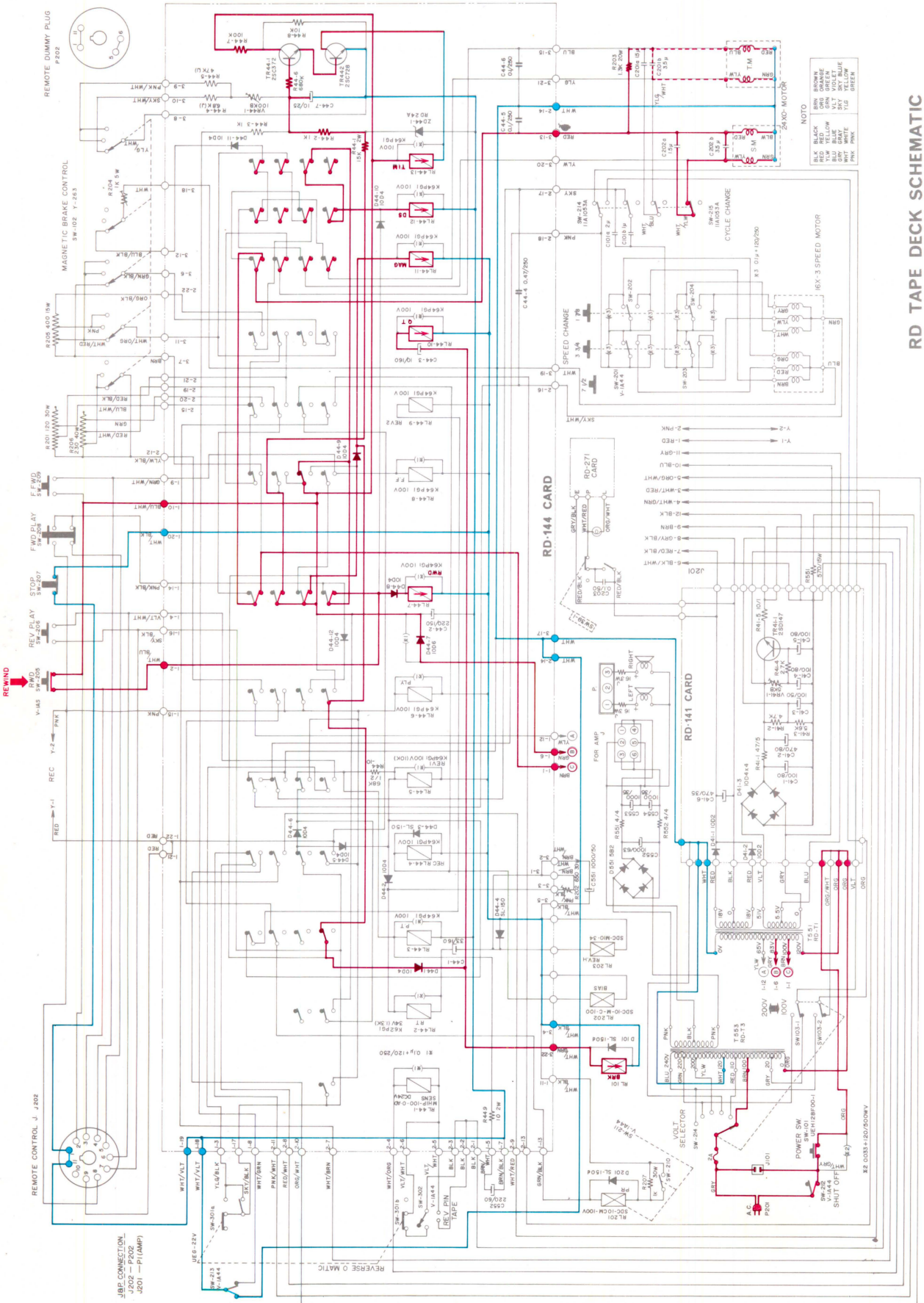

RD TAPE DECK SCHEMATIC

Fig. 5

# MAGNETIC BRAKE

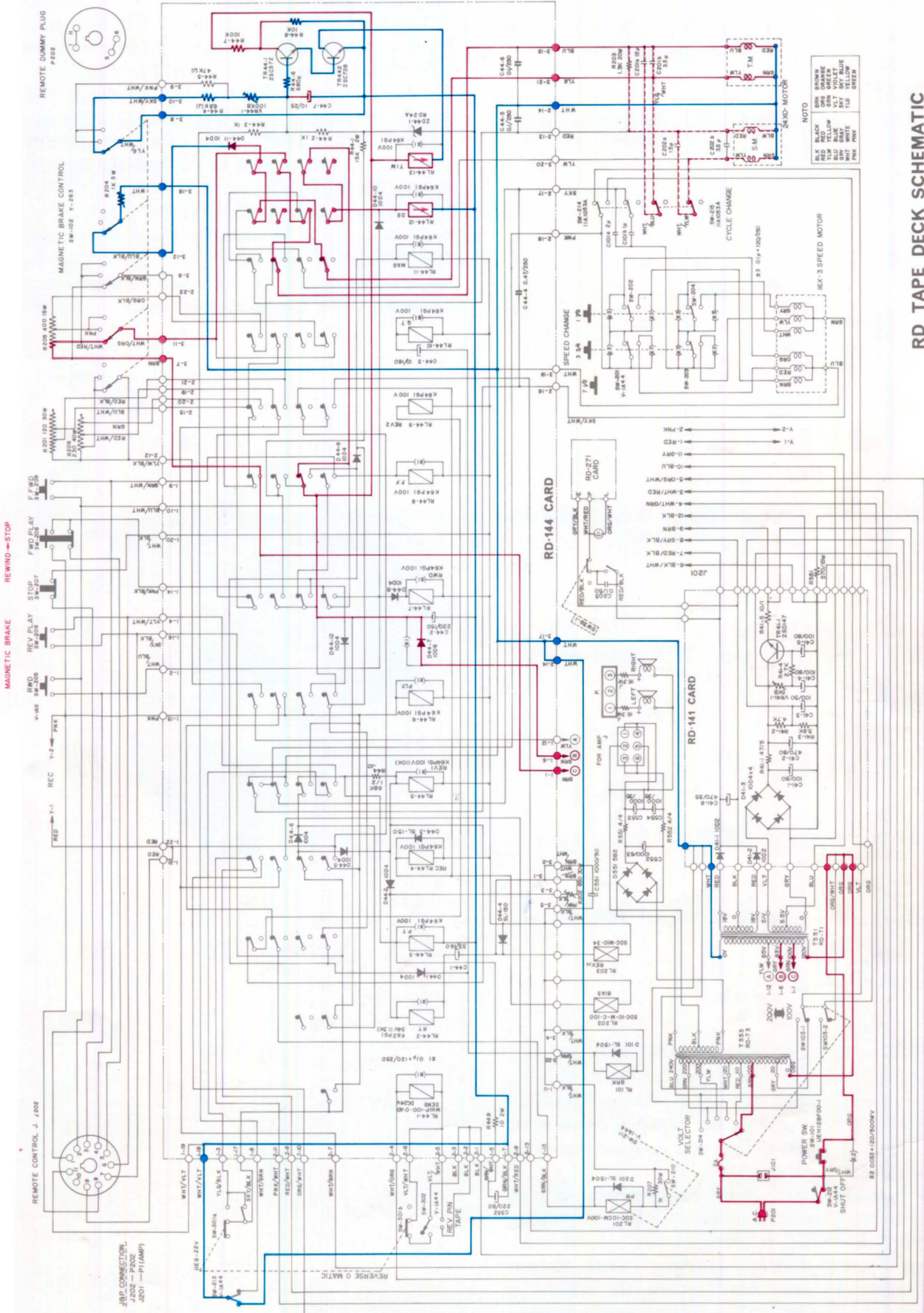

RD TAPE DECK SCHEMATIC

Fig. 6

## 7. REVERSE PLAY

a) Normal-----Reverse

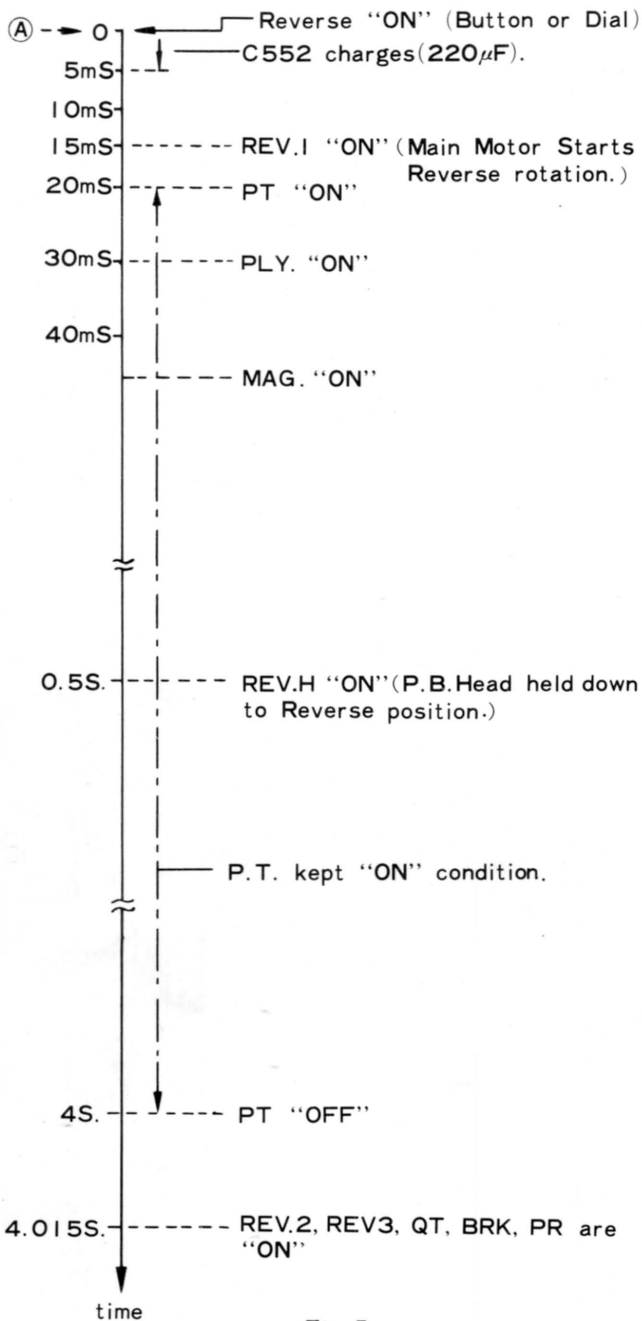
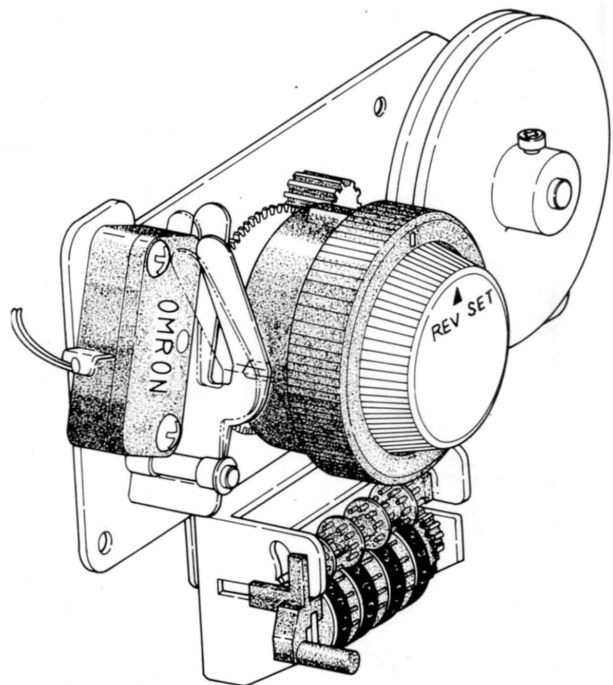

Fig. 7

15 milliseconds later, REV1 Relay is actuated ("ON") and the normally closed contact of REV1-2, is opened, 220  $\mu$ F is discharged through the 10  $\Omega$  Resistor and the PT Relay. The PT Relay remains engaged and the pinch roller disengages during the 4-second Discharge Time. The REV1 Relay is actuated ("ON") during this 4 seconds, starting the Main Motor rotating in the reverse direction. PLY and MAG Relays are actuated ("ON"), permitting current to flow to the Left and Right Reel Motors. The REV. H Solenoid is actuated ("ON"), the Playback Head lowers to its REVERSE position. The PT Relay is now cut off, and the pinch roller engages. Approximately 15 milliseconds later the REV2, REV3, and QT Relays and the BRK and PR Solenoids are actuated ("ON"), causing the tape travel to REVERSE.



Sequence of operation when the REVERSE Button is depressed, or when the White Mark on the Tape Count Meter reaches the Black Arrow of the Reverse Set Dial as follows for Automatic Reverse. Assuming this is point (A), Figure 7 shows Relay and Solenoid operating sequence beginning at this point.

Relay operation can be clearly understood by referring to the System Control Board Block Diagram (Figure 8.). As soon as REVERSE is actuated ("ON") at point (A), current begins to flow in the Reverse Circuit. Since it takes about 15 milliseconds before the contact is operative, C552 (220  $\mu$ F) is charged within approximately 5 milliseconds through REV1-2 (normally closed contact).

# REVERSE PLAY

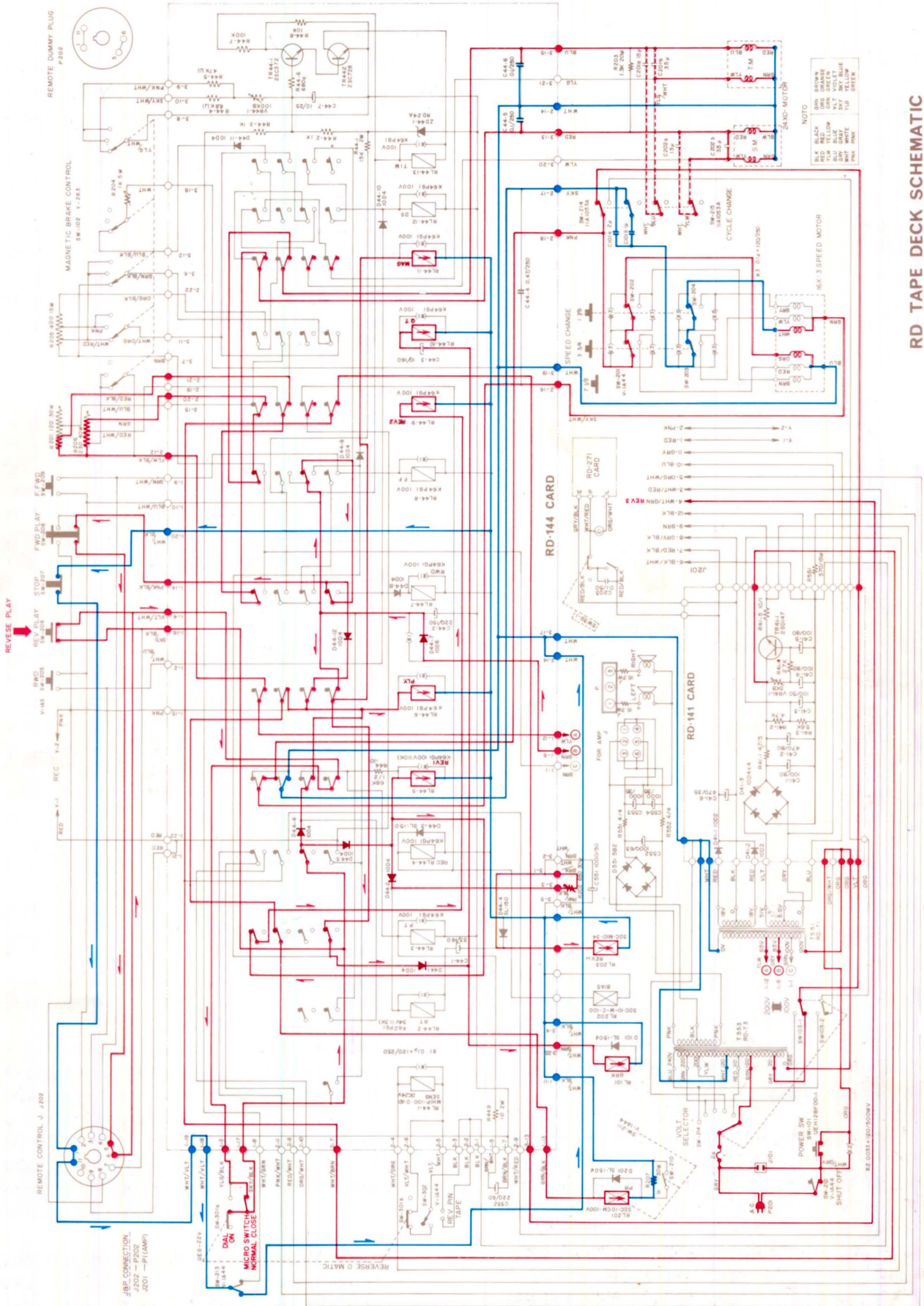

RD TAPE DECK SCHEMATIC

Fig. 8

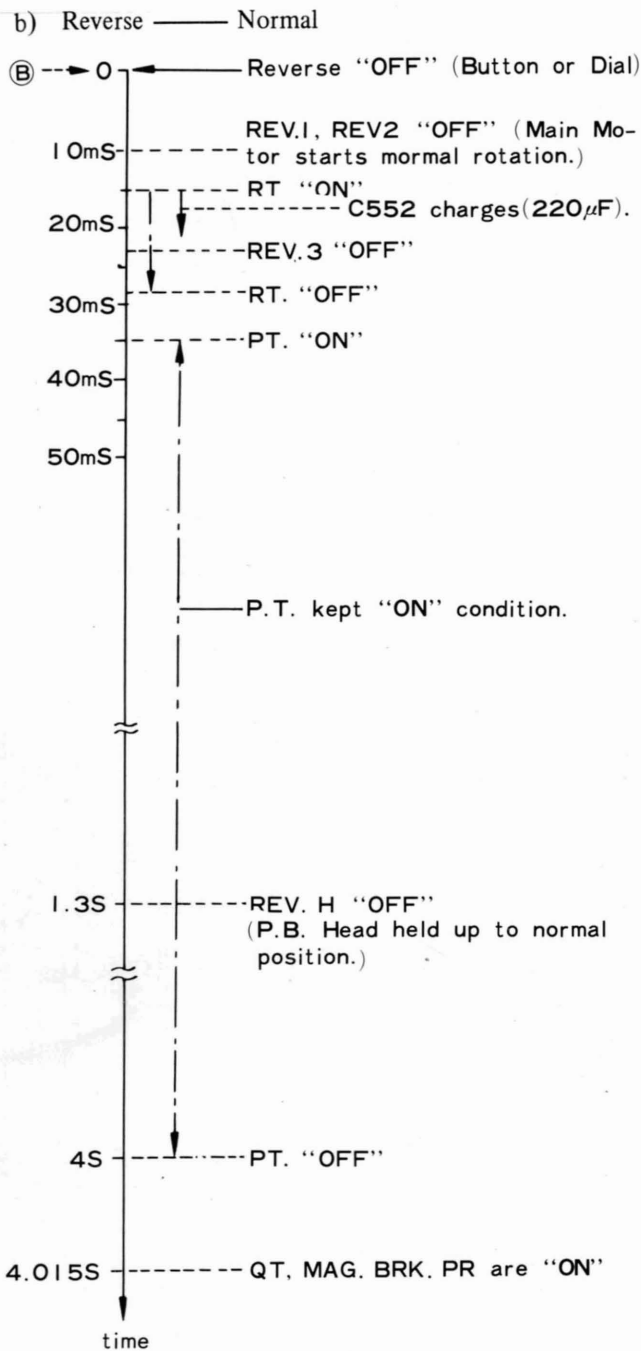

Fig. 9

Sequence of operation when the FORWARD Button is depressed during REVERSE PLAY, or when the White Mark on the Tape Count Meter reaches the "O" Mark on the Tape Count Scale used for Automatic Reverse is as follows, assuming this is point "B".

Reverse Circuit current is cut off at point(B), but REV1 and REV2 remain engaged for approximately 10 milliseconds. As REV1 is disengaged, the Main Motor starts rotating in the Normal direction. When the current in the Reverse Circuit is cut off, the 33 µF Condenser, which is series connects to the RT Relay and charged during Reverse Play, is discharged through the RT Relay Coil and the 650 Ω Resistor. The Discharge Time is about 28 milliseconds. Thus, the RT Relay remains engaged approximately 13 milliseconds. (See Figure 9)

RT1 normally open contact is closed and Condenser C552 (220 µF) is charged in approximately 5 milliseconds.

As RT1 closes, current starts flowing to the PT Relay Coil. As RT1 opens, C552 discharges and the PT Relay is engaged 35 milliseconds later, and continues to be operative for about 4 seconds, after which it is engaged. C551 (1000 µF) discharges current to the REV.H Solenoid Coil. in approximately 1.3 seconds after point (B), the REV.H is disengaged and the Playback Head raises to its Normal Play position.

As the PT Relay is disengaged, current flows to QT and MAG Relays and to BRK and PR Solenoids through the normally closed contacts. After approximately 15 milliseconds, the QT and MAG Relays and the BRK and PR Solenoids are actuated ("ON"), and tape travel starts in the Normal direction.

#### 8. Comput-O-matic

a) By depressing the Set Button (SW25-1) with no input signal applied to Line Input or Microphone Jacks, current flows to the Comput-O-Matic Motor through the Relay (MH2PM-0) (a normally closed contact) and the Microswitch (SW92-1), causing the Motor to rotate in the direction indicated by the blue line in Figure 10.

The Motor Shaft is connected to the Comput-O-Matic Volume Control Shaft by gear mechanism. When the Motor rotates in the direction indicated by the blue line, the Volume Control turns toward the upper limit (maximum). When the Volume Control reaches the upper limit, Microswitch SW92-1 is cut off by the cam attached to the Volume Control Shaft, cutting the flow of current to the Motor, thus, stopping the Motor.

As current is cut off, Bias Voltage is applied to Transistor TR70-8, through R70-23 and R70-22, actuating TR70-8. As TR70-8 is actuated ("ON") collector current flows through the Relay Coil MH2PM-0, engaging the Relay. However, when no input signal is applied, current does not flow to the Motor because Transistor TR70-7 is inoperative (OFF), as shown in Figure 10.

b) Under conditions as described above, but when input signals are applied to the Line Input or Microphone Input Jacks (for input signals level of 0 VU or greater) the function of Transistors are as shown by the red print in Figure 10. As TR70-7 is actuated, TR70-7 collector current flows through the Motor, causing the Motor to rotate in the direction indicated by the red arrow in Figure 10.

As the Motor rotates in the direction indicated by the red arrow, the Volume Control rotates from the upper limit toward the lower limit (minimum). The input signals applied to the

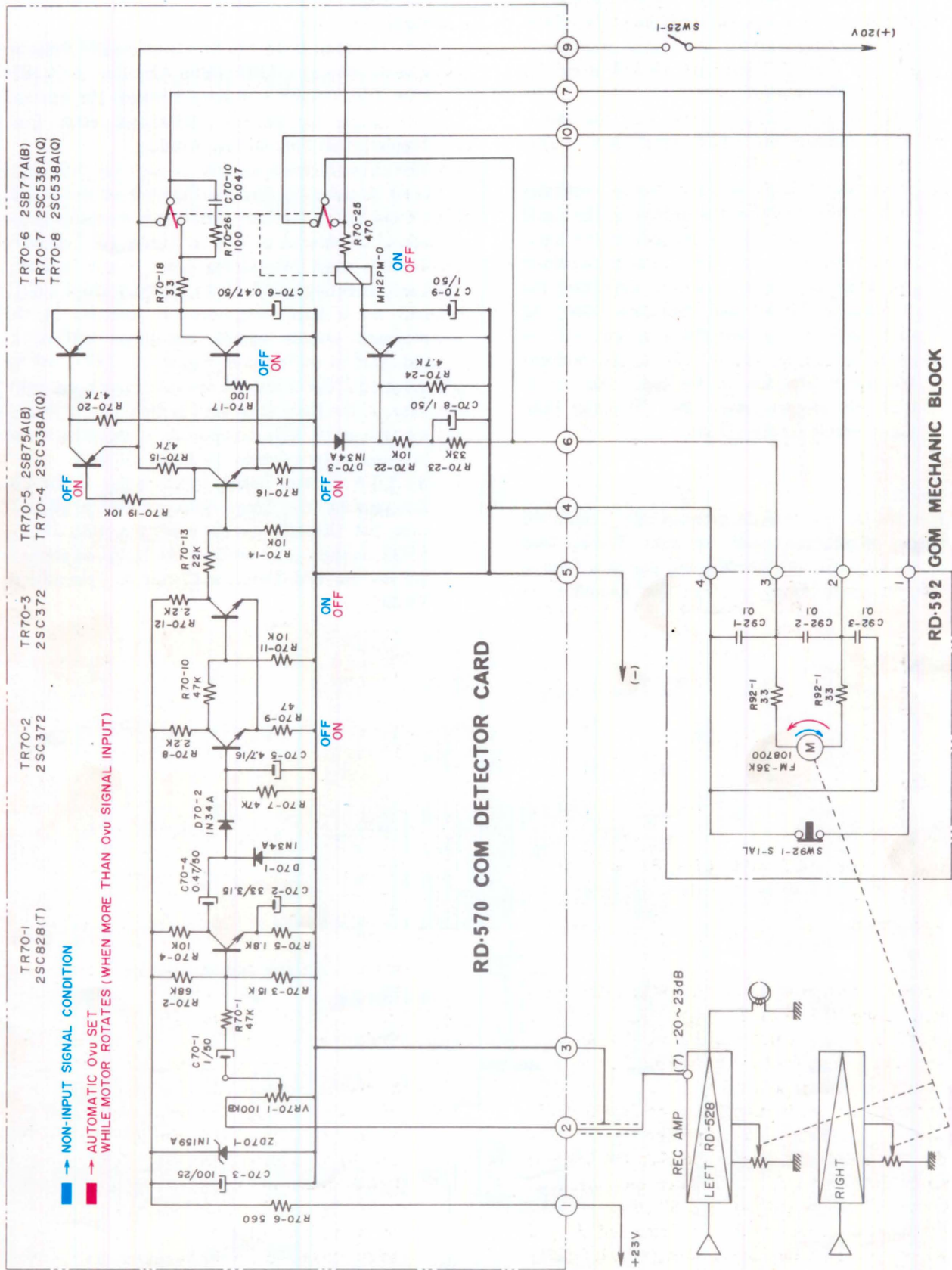

Fig. 10

Recording Amplifier are decreased by the Volume Control, and the COM Detector Card input signal level is reduced accordingly.

When the signal level to the Recording Amplifier is reduced to 0 VU, the conditions of the COM Detector Card Transistors are again as indicated in blue print in Figure 10, TR70-7 is cut off and the Motor stops.

TR70-5 and TR70-6 insure that the Motor stops immediately when signal level reaches 0 VU.

- c) Since the Comput-O-Matic Motor operates only in the direction for decreasing the signal level (with input signals applied), if the input signal becomes too low, Comput-O-Matic recording level must be reset by depressing the Set Button "OFF" and then back "ON". At this time, Relay MH2PM-0 is cut off (as described in (a) above). Thus, the Volume Control rotates toward the upper limit, automatically stopping when the VU Meter Indicator Needle registers 0 VU.

#### 9. DM Detector

The DM Detector Circuit automatically detects the quality of recorded sound, and when Playback level deteriorates during recording and playback (due to dirt, magnetic oxide, etc. on the Recording or

Playback Heads), the D.M. Indicator Lamp lights.

9 KHz is used as a drive signal for the DM Detector Circuit. The DM Detector Card is connected to the 1st Stage of the Playback Amplifier, as shown in Figure 11.

The 1st through the 5th Stages of the DM Detector Circuit serve as a 9 KHz Filter Amplifier. A 90 KHz Bias Trap Circuit is inserted between the 4th and 5th Stages to prevent operational error from Magnetic Bias Flux during recording.

The circuitry from the 6th through the 9th Stages serve as switching circuits. Presence of the 9 KHz component in Playback output signals results in the condition printed in blue in Figure 11, Transistor TR71-9 stops functioning and the DM Indicator Lamp is extinguished. If the Playback Head is dirty and no 9 KHz component is included in the playback output signals, conditions will be as indicated in red print in Figure 11, TR1-9 will be actuated ("ON") and the Indicator Lamp will light. Also, if the Recording Head is dirty during recording and no 9 KHz component is included in the playback output signals, the Lamp will light.

At 1-7/8 ips tape speed, power is cut to the DM Detector by the Speed Selector Switch SW39-1, thus DM Detector circuit won't function. During STOP, as there is no need for the Lamp, so power is cut to the DM Detector Circuit by Microswitch SW207.

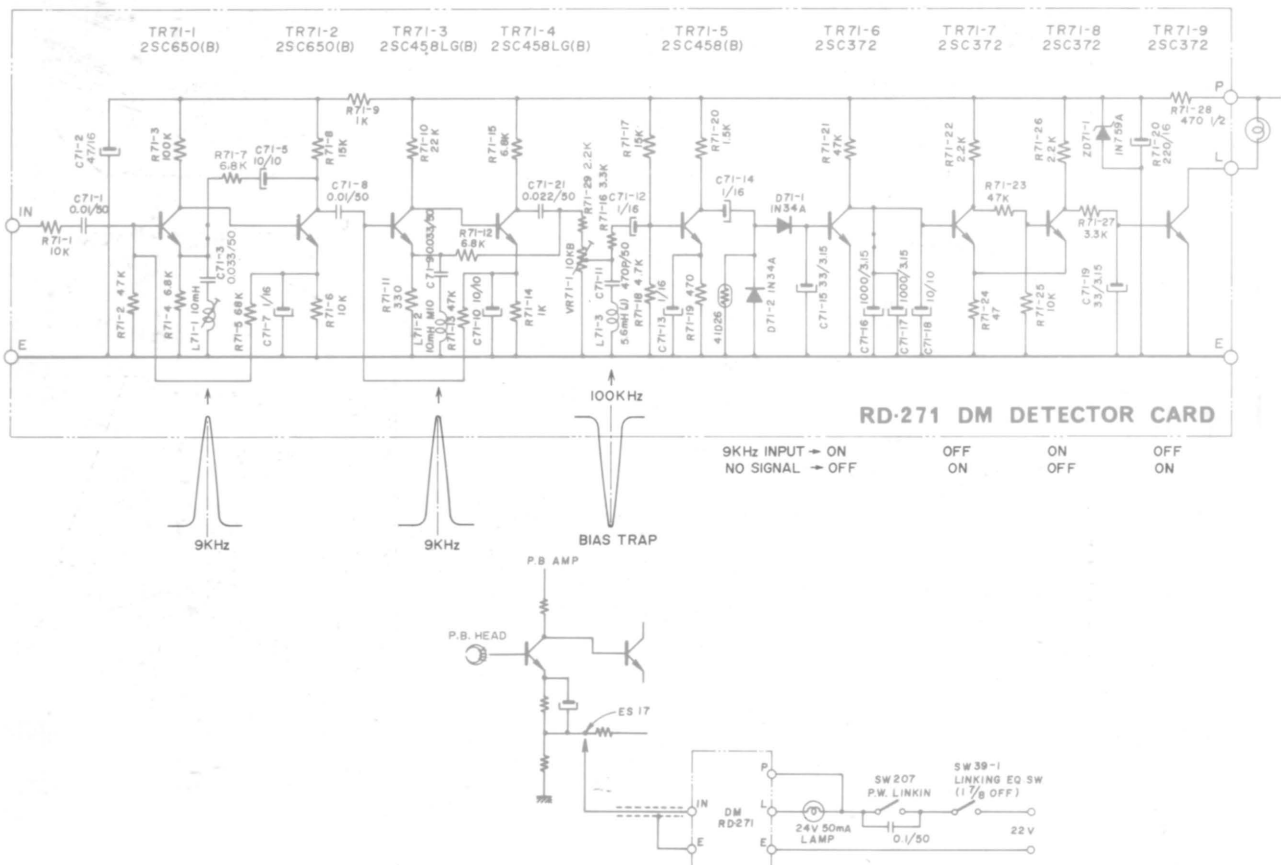

Fig. 11



# IX. MAINTENANCE PROCEDURES

## 1. LUBRICATION INSTRUCTION

For maximum service life and optimum performance, lubricate the parts identified below after each 1,000 ~ 1,500 hours of operation. Use only light machine oil of good quality.

- Main Motor
- Capstan Shaft
- Pinch Wheel Shaft
- Tape Counter

Also apply a liberal film of light machine grease to each roller surface of all levers and cams.

**CAUTION: DO NOT OVER-LUBRICATE, AND WIPE OFF EXCESS OIL WITH A COTTON SWAB SOAKED IN ALCOHOL. OTHERWISE, EXCESS LUBRICANT MAY BE SCATTERED DURING OPERATION. AND THE RUBBER COMPONENT PARTS WILL DETERIORATE.**

## 2. CLEANING TAPE HEADS AND OTHER

Wipe surface of tape heads, guide roller bearing, capstan bushing and pinch wheel periodically with a soft cloth soaked in alcohol or carbon-tet.

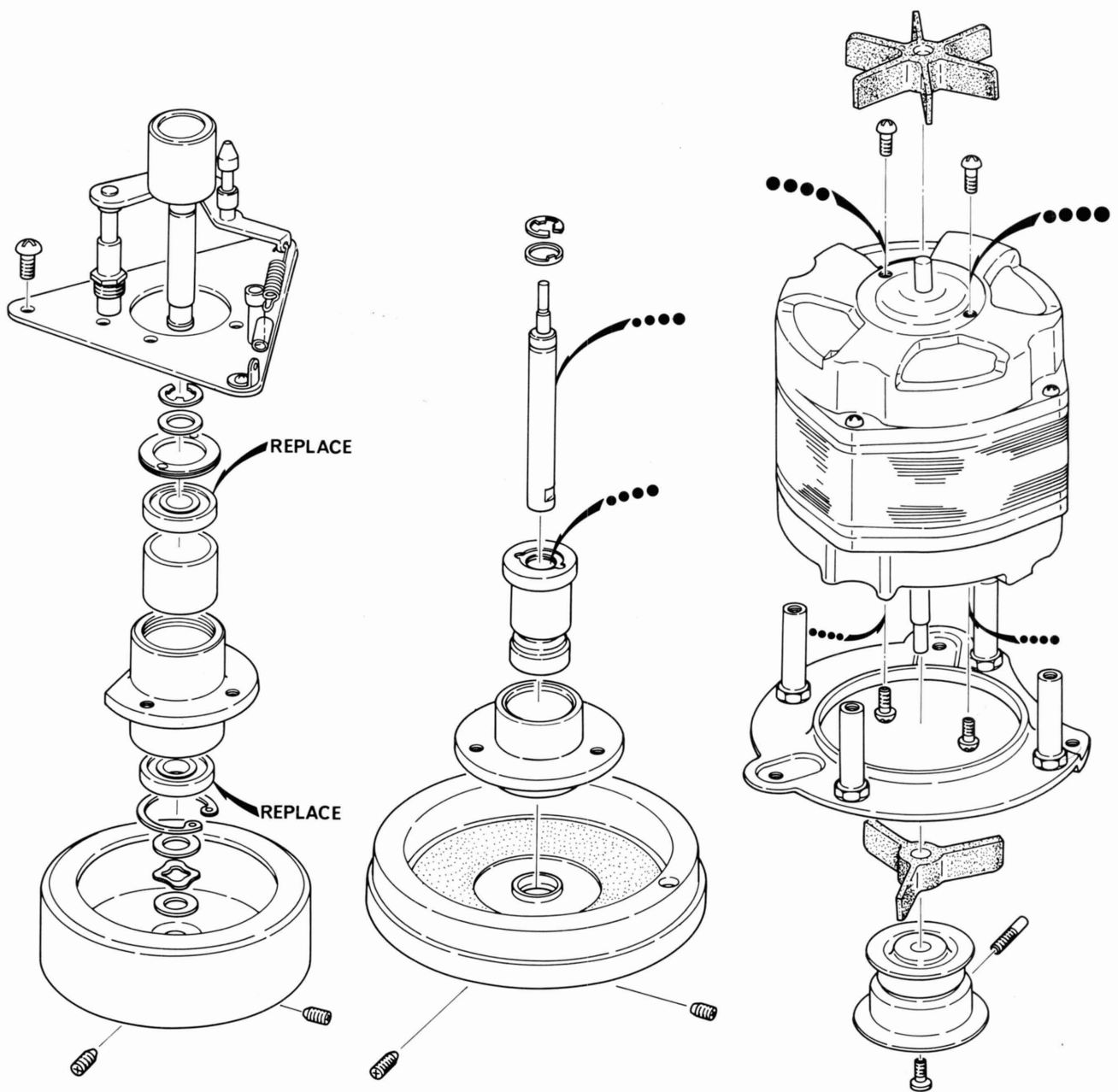

# X. TROUBLE SHOOTING CHART

## SECTION "A" TAPE TRANSPORT MECHANISM TROUBLES

- \* If all relays do not operate, first, check the REMOTE DUMMY PLUG (P202).
- \* Next, check D10D (D44-7) (Relay, Power Supply) and Condenser 220  $\mu$ F or 100  $\mu$ F 150V.
- \* Check the Relay Print Circuit Board as shown in Fig. First, check each connection point (blank point).
- \* When there are no troubles that relays and diodes have the normal resistances and distortions.

### 1. Capstan fails to rotate.

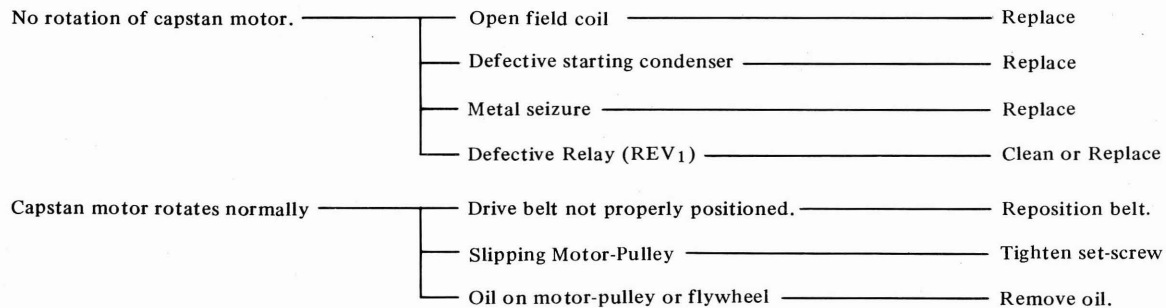

### 2. No tape movement in "Play" mode.

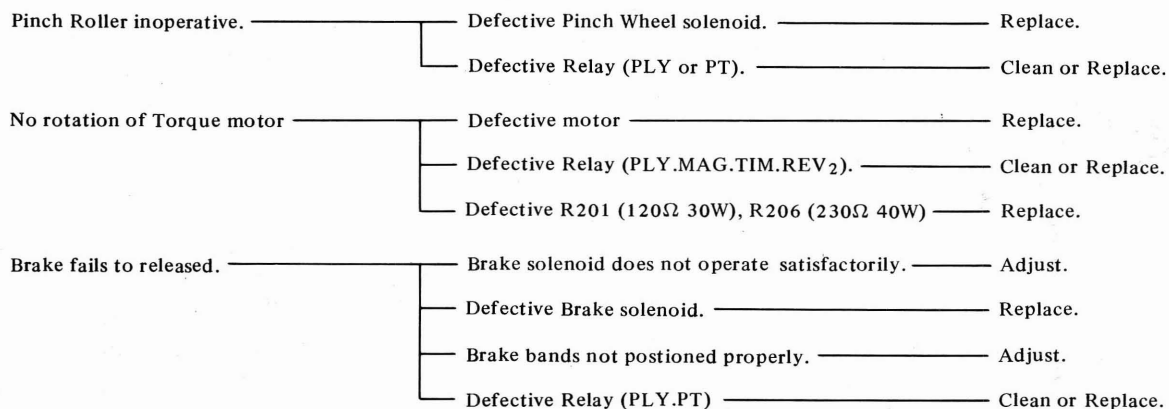

### 3. No "Reverse Play"

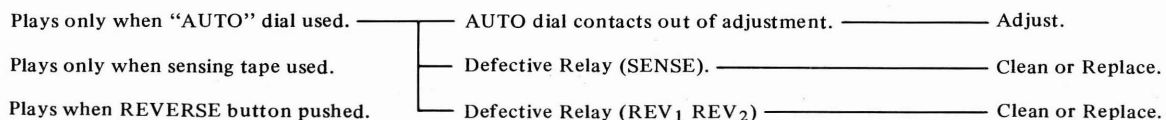

### 4. Inproper Reverse Operation

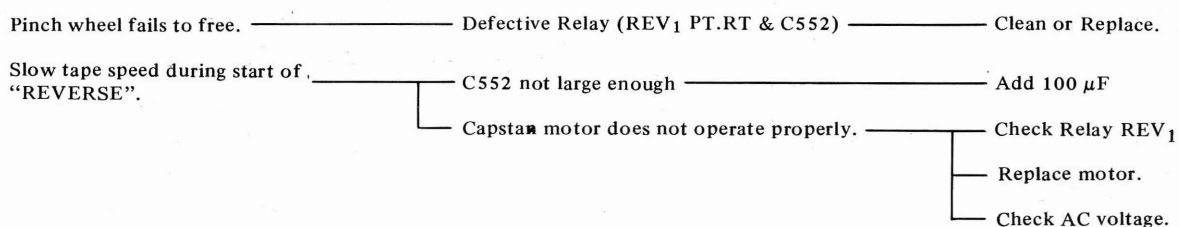

### 5. No rewind.

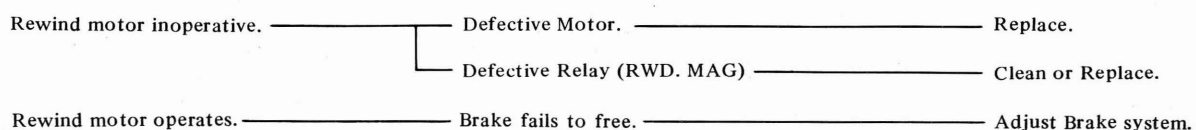

6. No "Fast FWD"

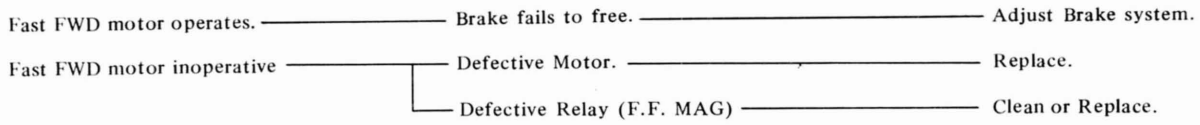

7. Improper Brake operation.

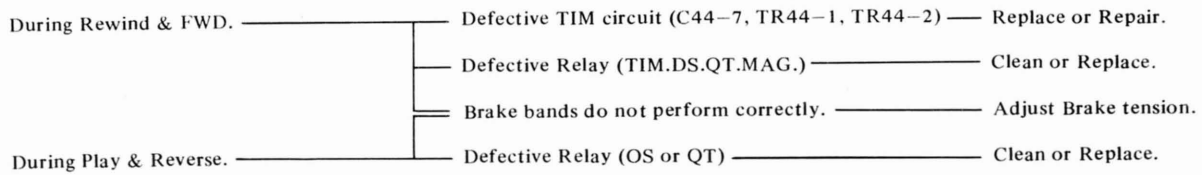

8. Wow, Flutter excessive.

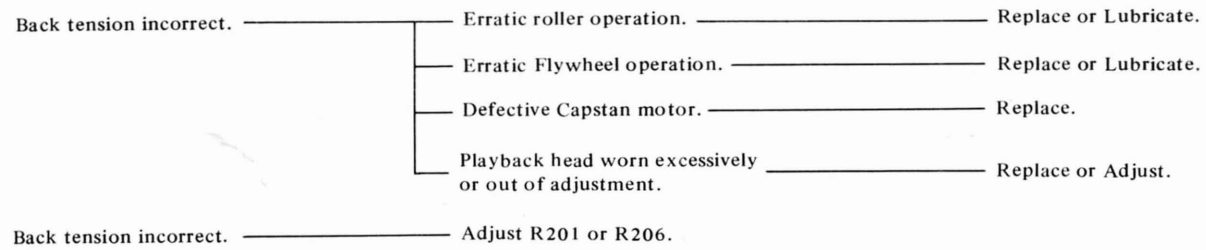

9. Tape speed too slow.

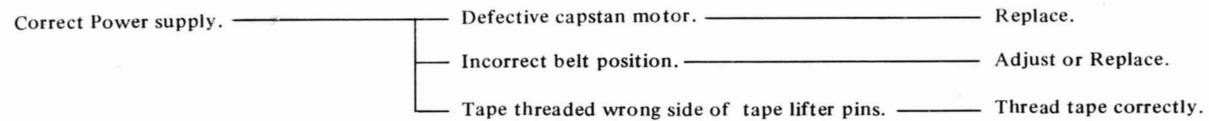

## SECTION "B" TROUBLES WITH AMPLIFIER

### A. Playback system troubles.

1. No sound from loud speaker.

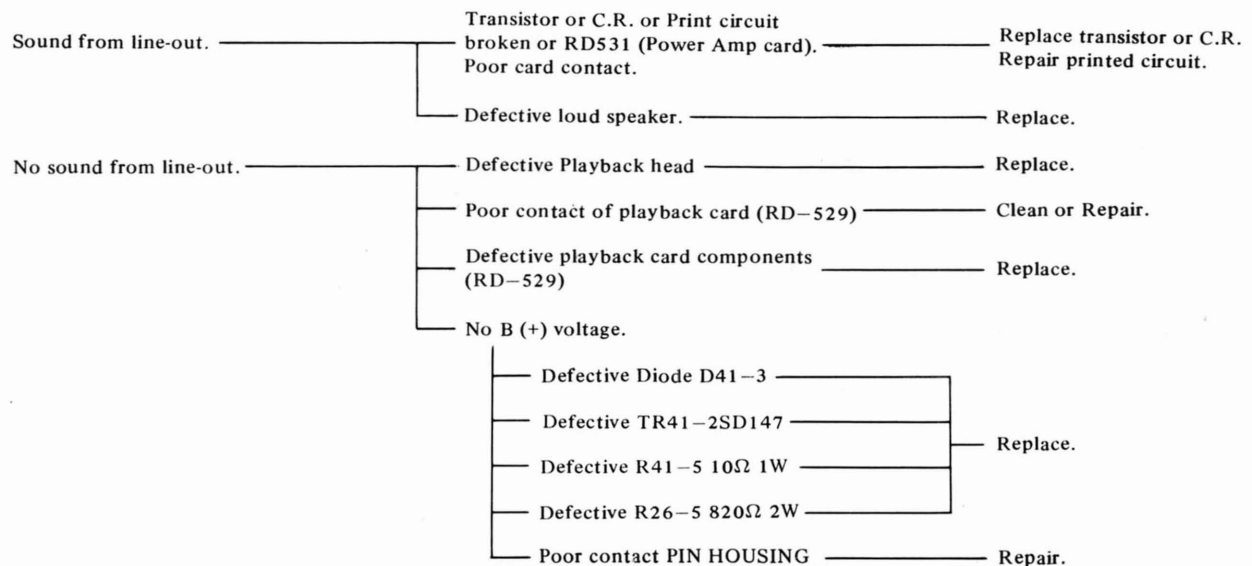

Intermittent sound cut out. ————— Defective Relay (REV. PL22-2) ————— Clean or Replace.  
 ————— Poor contact on Track Selector Card (RD-522) ————— Repair

2. Distorted sound

Satisfactory sound from Line-out. ————— Defective transistor or C.R. on RD-531. ————— Replace.

Sound distorted from Line-out. ————— Defective playback card components (RD-529). ————— Replace.  
 ————— Excessive playback head wear. ————— Replace.

3. Excessive Hum.

Hum decreased when playback head shorted. ————— Defective playback head. ————— Replace.

Hum not due to playback head. ————— Defective power supply circuit parts. ————— Replace.  
 ————— Broken or disconnected ground wire. ————— Repair.

4. Scratching or cracking sounds.

Noise during tape operation. ————— Magnetized head. ————— Demagnetize head.  
 ————— Noisy tape. ————— Replace tape.

Not due to tape. ————— Defective transistors on the playback card. ————— Replace.

5. Normal Reverse sound unequal

Head alignment. Incorrect height. adjustment. ————— Readjust or Replace head.

6. Improper function of dust minder

Lamp keeps lighting or remains lit. ————— Transistor or C7-2 defective on the Detector Card ————— Replace.

————— Incorrect adjustment of VR71-1 10K ————— Readjust.

Lamp fails to light. ————— Defective lamp ————— Replace.

**B. Recording system troubles.**

\* Before any trouble shootings, clean and demagnetize heads first.

1. Recording not possible.

Recording lamp fails to light. (OSC does not work.) ————— Defective relay RL-44-4 (REC<sub>1</sub>) ————— Clean or Replace.  
 ————— Defective transistors or the OSC card (RD-530) ————— Replace.

Recording lamp lights. ————— Defective relay RL2201 (REC<sub>2</sub>) ————— Clean or Replace.  
 ————— Bias head does not shift to correct position. ————— Replace or Adjust bias solenoid.  
 ————— VU meter indicates normal. ————— Defective head. ————— Replace.  
 ————— Defective transistors on the record card. ————— Replace.  
 ————— No VU meter indication. ————— Defective transistors on the record card (RD-528) ————— Replace.

---

2. No VU meter indication.

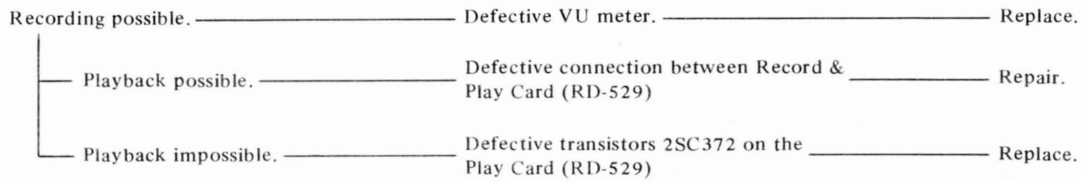

3. Distorted sound.

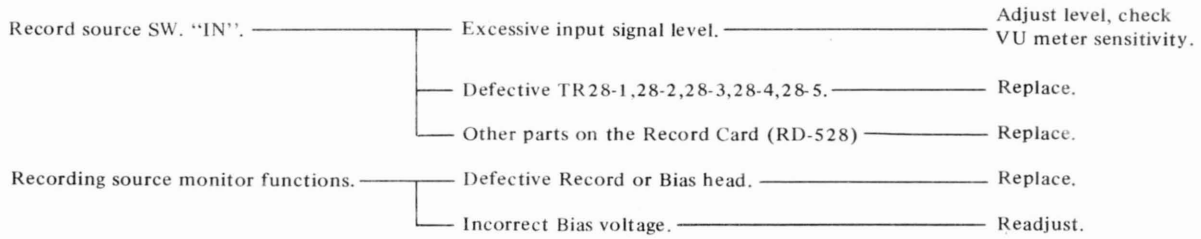

4. Faulty Erasing

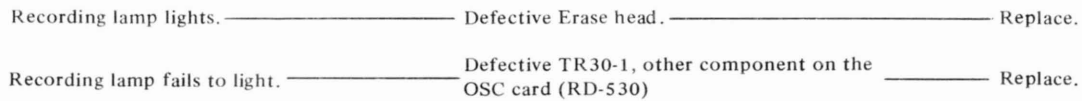

5. Improper function of Auto VR

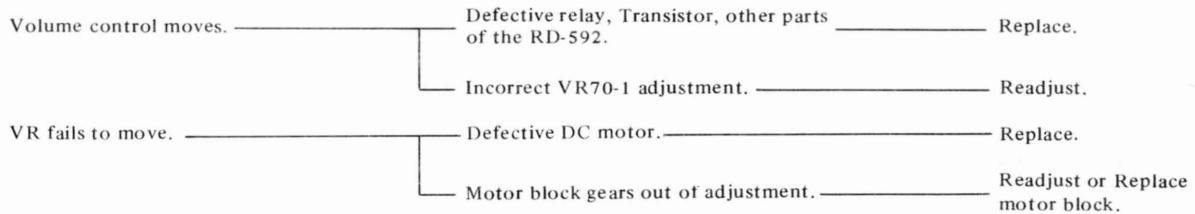

---

**MEMO**

# XI. REPLACEMENT PARTS TABLE

---

## X-360 PARTS LIST

	<b>Page</b>
HEAD BLOCK	RD-1100 ..... 38
CAPSTAN & PINCH WHEEL BLOCK	RD-1200 ..... 41
STABILIZER BLOCK	RD-1300 ..... 41
CYCLE CHANGE BLOCK	RD-1700 ..... 43
MECHANISM CHASSIS	RD-2000 ..... 43
REEL MOTOR & TABLE BLOCK	RD-1400 ..... 45
REVERSE MECHANISM BLOCK	RD-1600 ..... 45
MAIN MOTOR BLOCK	RD-1500 ..... 47
BRAKE BLOCK	RD-1800 ..... 47
RESISTOR BLOCK	RD-1900 ..... 47
RELAY BOARD BLOCK	RD-144 ..... 48
POWER SOURCE BLOCK	RD-2100 ..... 50
POWER SOURCE PRINTED BOARD	RD-141 ..... 52
OSCILLATOR BOARD	RD-530 ..... 53
DM DETECTOR BOARD	RD-271 ..... 54
PLAYBACK PRE-AMPLIFIER BOARD	RD-529 ..... 56
RECORDING AMPLIFIER BOARD	RD-528 ..... 58
MAIN AMPLIFIER BOARD	RD-531 ..... 60
MONITOR SWITCH BOARD	RD-523 ..... 62
TRACK SELECTOR BOARD	RD-522 ..... 63
C.O.M. DETECTOR BOARD	RD-570 ..... 64
C.O.M. SET SWITCH BLOCK	RD-525 ..... 66
C.O.M. MECHANIC BLOCK	RD-2200 ..... 67
SPARK QUENCHER & SWITCH BLOCK	RD-150B ..... 68
SPEED SELECTOR SWITCH BLOCK	RD-139B ..... 69
AMPLIFIER CHASSIS BLOCK	RD-2300 ..... 70
CASE & PANEL BLOCK	RD-2500 ..... 72
HEADPHONE CONNECTION BOARD (X-360D only)	RD-524 ..... 74
CHASSIS PRINTED BOARD	RD-526 ..... 75
MAIN AMPLIFIER SOCKET BOARD	RD-532 ..... 75

PARTS TABLE 1

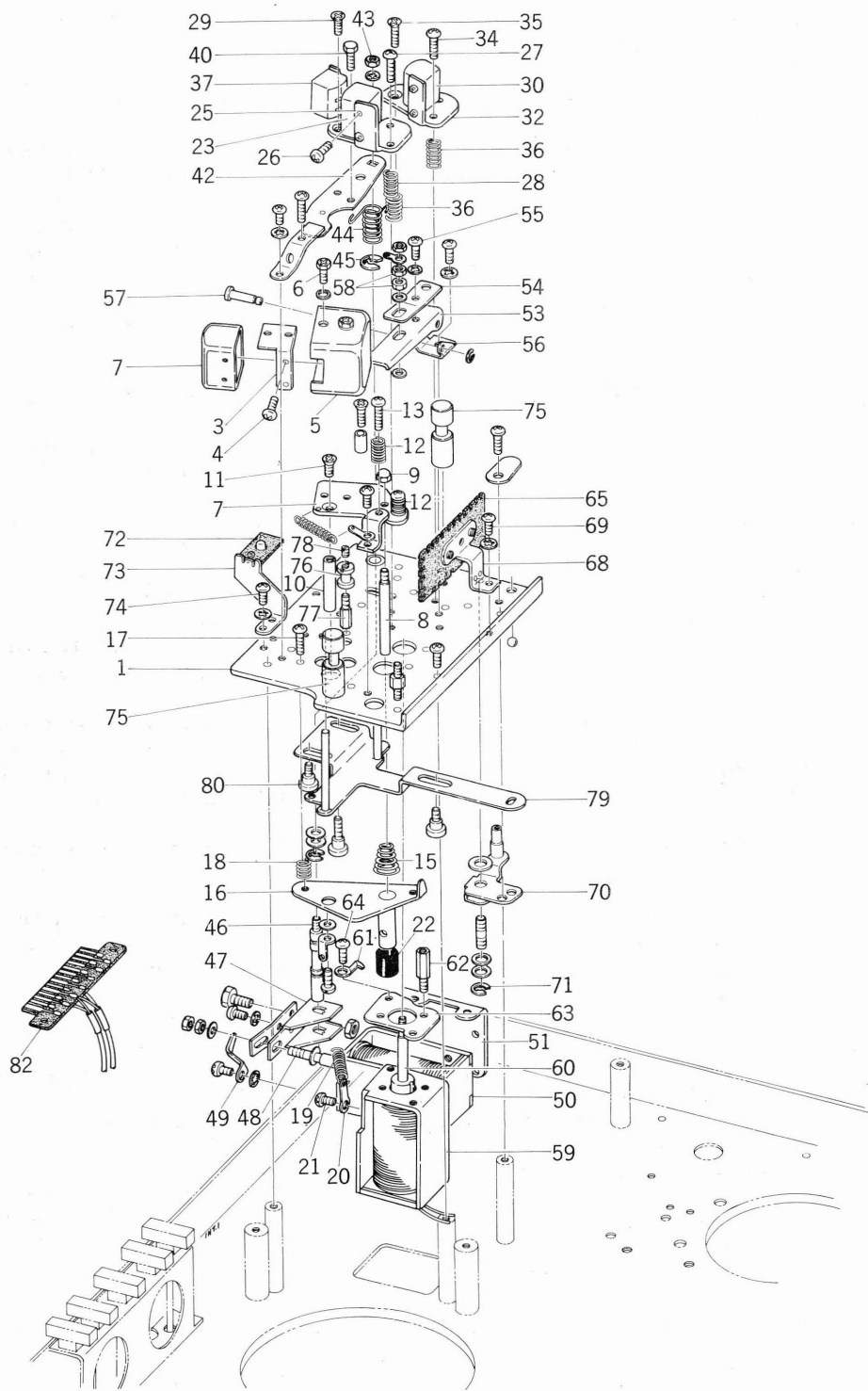

HEAD BLOCK (RD-1100)

Ref. No.	Parts No.	Nomenclature	Quantity	Ref. No.	Parts No.	Nomenclature	Quantity
0	RD-1100	Head Assembly Complete	1	6	RD-1106	Hexagon Head Screw (Bracket Mounting)	2
1	RD-1101	Chassis, Head Assembly	1	7	RD-1107	Plate, Shielded Case Mounting	1
2	RD-1102	Playback Head	1	8	RD-1108	Shaft, Playback Head Mounting	1
3	RD-1103	Bracket, P.B. Head Mounting	1	9	RD-1109	Cap Nut, 3 mm, Shaft Mounting	1
4	RD-1104	Screw, pan head 2 x 3 mm (Head Mounting)	2	10	RD-1110	Guide prop, Playback Head	1
5	RD-1105	Shielded Case, Playback Head	1	11	RD-1111	Screw, flat head 3 x 6 mm	1



PARTS TABLE 1

Ref. No.	Parts No.	Nomenclature	Quantity	Ref. No.	Parts No.	Nomenclature	Quantity
12	RD-1112	Spring, Head Height Adjustment	1	45	RD-1145	"U" Ring	1
13	RD-1113	Screw, round head 3 x 10 mm	1	46	RD-1146	Prop, Bias Head Activating	1
14	RD-1114	Screw, round head 3 x 4 mm	2	47	RD-1147	Solenoid Link, Bias Head Activating	1
15	RD-1115	Spider Spring, Head up-down	1	48	RD-1148	Link, Solenoid Plunger	1
16	RD-1116	Plate, P.B. Head Angle Adjustment	1	49	RD-1149	Solenoid Stopper	1
17	RD-1117	Screw, round head 3 x 15 mm	3	50	RD-1150	Solenoid (SDC-10-M-C-100), Bias Head Activating	
18	RD-1118	Spring, P.B. Head Angle Adjustment	3	51	RD-1151	Bracket, Solenoid Mounting	1
19	RD-1119	Spring, P.B. Head Tension	1	52	RD-1152	Screw, binding head 3 x 5 mm	3
20	RD-1120	4 mm Lug Plate	1	53	RD-1153	Lever, Playback Head Activating	1
21	RD-1121	Screw, round head, Lug Plate Mounting 3 x 5 mm	1	54	RD-1154	Bar Spring	1
22	RD-1122	Dust Cover Cap	1	55	RD-1155	Screw, binding head 3 x 5 mm	1
23	RD-1123	Recording Head	1	56	RD-1156	Bracket, Lever Mounting	1
24	RD-1124	Spacer Metal, Recording Head Mounting	1	57	RD-1157	Prop, Lever Mounting	1
25	RD-1125	Bracket, Recording Head Mounting	1	58	RD-1158	Nut 3 mm	3
26	RD-1126	Screw, pan head 2 x 4 mm (Head Mounting)	2	59	RD-1159	Solenoid SDC-M-10D-34, Playback Head Activating	
27	RD-1127	Screw, round head 3 x 12 mm (Bracket Mounting)	1	60	RD-1160	Link, Solenoid Plunger	1
28	RD-1128	Spring, Head Angle Adjustment	3	61	RD-1161	Solenoid Stopper	1
29	RD-1129	Screw, counter sunk head 3 x 12 mm (Bracket Mounting)	1	62	RD-1162	Hexagonal Prop, Solenoid Mounting	2
30	RD-1130	Erase Head	1	63	RD-1163	Plate, Solenoid Mounting	1
31	RD-1131	Spacer Metal, Erase Head Mounting	1	64	RD-1164	Screw, binding head 3 x 5 mm	2
32	RD-1132	Bracket, Erase Head Mounting	1	65	RD-1165	Printed Board, RD-43 (Head Connection)	1
33	RD-1133	Screw, pan head 2 x 4 mm (Head Mounting)	2	66	RD-1166	Capacitor, C3-1 330P/35V	1
34	RD-1134	Screw, round head 3 x 12 mm (Bracket Mounting)	1	67	RD-1167	Capacitor, C3-2 330P/35V	1
35	RD-1135	Screw, counter sunk head 3 x 12 mm (Bracket Mounting)	1	68	RD-1168	Bracket, Printed Board Mounting	1
36	RD-1136	Spring, Head Angle Adjustment	3	69	RD-1169	Screw, binding head 3 x 5 mm with washer	3
37	RD-1137	Bias Head	1	70	RD-1170	Tape Cleaner Lever	1
38	RD-1138	Bracket, Bias Head Mounting	1	71	RD-1171	"U" Ring, Cleaner Lever Mounting	1
39	RD-1139	Screw, pan head 2 x 4 mm (Head Mounting)	2	72	RD-1172	Printed Board (RD-53, DM Lamp Mounting)	1
40	RD-1140	Screw, hexagonal head 3 x 4 mm (Bracket Mounting)	2	73	RD-1173	Bracket, Printed Board Mounting	1
41	RD-1141	Washer 7.8 x 0.5 mm	2	74	RD-1174	Screw, binding head 3 x 5 mm with washer	1
42	RD-1142	Lever, Bias Head Activating	1	75	RD-1175	Tape Guide A	2
43	RD-1143	Nut 3 mm (lever Mounting)	1	76	RD-1176	Tape Guide B	2
44	RD-1144	Spring, Bias Head hold-down	1	77	RD-1177	Hexagonal Prop, Tape Guide Mounting	2
				78	RD-1178	Set Screw 3 x 5 mm	2
				79	RD-1179	Tape Shifter Lever	1
				80	RD-1180	Guide Screw, flat head 3 x 5 mm (Tape Shifter Mounting)	2
				81	RD-1181	Screw, round head 3 x 12 mm	1
				82	RD-1182	Printed Plug, 14 P	1

PARTS TABLE 2

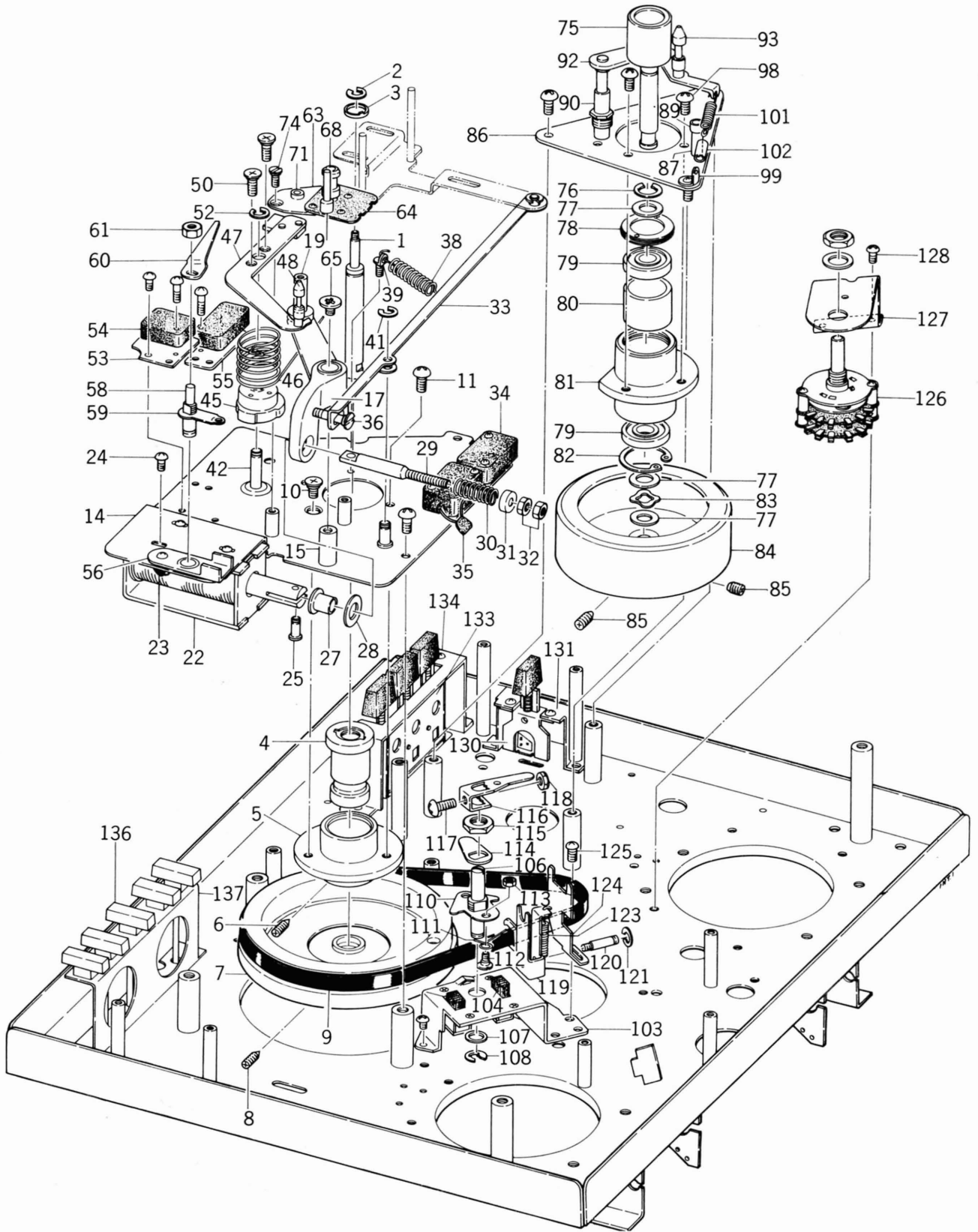

PARTS TABLE 2

**CAPSTAN & PINCH ROLLER BLOCK (RD-1200)**

Ref. No.	Parts No.	Nomenclature	Quantity
0	RD-1200	Capstan Flywheel Assembly Complete	1
1	RD-1201	Capstan Shaft	1
2	RD-1202	"E" Ring, Capstan Shaft	1
3	RD-1203	Nylon Washer, Capstan Shaft (Claw washer)	1
4	RD-1204	Bearing, Capstan	1
5	RD-1205	Bearing Case, Capstan	1
6	RD-1206	Set Screw 4 x 6 mm, Bearing Mounting	2
7	RD-1207	Flywheel, Capstan	1
8	RD-1208	Set Screw, 5 x 6 mm, Flywheel Mounting	2
9	RD-1209	Capstan Drive Belt (diameter 120 mm)	1
10	RD-1210	Screw, counter sunk head 4 x 8 mm (Flywheel Mounting)	1
11	RD-1211	Screw, pan head 4 x 8 mm, Flywheel Mounting	2
12	RD-1212	Pinch Roller (for 7.5 ips)	1
13	RD-1213	Pinch Roller Cap	1
14	RD-1214	Chassis, Flywheel Mounting	1
15	RD-1215	Shaft, Pinch Roller Lever	1
16	RD-1216	Washer 13 x 0.2 mm, Pinch Roller Lever	1
17	RD-1217	Lever, Pinch Roller Activating	1
18	RD-1218	Screw, flat head 4 x 6 mm	1
19	RD-1219	Shaft, Pinch Roller Mounting	1
20	RD-1220	Washer 10.3 x 0.8 mm, Pinch Roller Shaft	1
21	RD-1221	Nut 4 mm	1
22	RD-1222	Solenoid SDC-10CM-100V, Pinch Roller Activating	1
23	RD-1223	Diode SL-150	1
24	RD-1224	Screw, pan head 3 x 5 mm, Solenoid Mounting	3
25	RD-1225	Connection Pin 3 x 15.5 mm	1
26	RD-1226	"E" Ring, 1.9 mm (for Connection Pin)	1
27	RD-1227	Metal Sleeve	1
28	RD-1228	Washer 16 x 1 mm	1
29	RD-1229	Shaft, Solenoid Link	1
30	RD-1230	Spring, Pinch Roller Tension	1
31	RD-1231	Spring Stopper	1
32	RD-1232	Cap, Nut 4mm	2
33	RD-1233	Lever, Tape Shifter Activating	1
34	RD-1234	Micro Switch V-1A44	2
35	RD-1235	Capacitor 0.1µF 50V	1
36	RD-1236	Screw 4 x 20 mm, Lever Mounting	1
37	RD-1237	Nut 4 mm	1
38	RD-1238	Spring, Tape Shifter Lever Tension	1

Ref. No.	Parts No.	Nomenclature	Quantity
39	RD-1239	Bracket, Spring Holder	1
40	RD-1240	Screw, pan head 4 x 6 mm	1
41	RD-1241	"U" Ring	2
42	RD-1242	Shaft, Tension Arm	1
43	RD-1243	Nut 4 mm	1
44	RD-1244	Washer	1
45	RD-1245	Cam, Shut-off Switch Activating	1
46	RD-1246	Spring, Tension Arm	1
47	RD-1247	Tension Arm	1
48	RD-1248	Tape Guide C, Tension Arm	1
49	RD-1249	Screw, counter sunk head 3 x 6 mm	1
50	RD-1250	Screw, counter sunk head 2.3 x 12 mm	2
51	RD-1251	Nut 2.3 mm	2
52	RD-1252	"U" Ring	1
53	RD-1253	Plate A, Micro Switch Mounting	1
54	RD-1254	Micro Switch V-1A44	2
55	RD-1255	Plate B, Micro Switch Mounting	1
56	RD-1256	Plate, Tension Arm Stop Lever Mounting	1
57	RD-1257	Screw, pan head 3 x 5 mm	1
58	RD-1258	Shaft, Stop Lever	1
59	RD-1259	Leaf Spring, Stop Lever	1
60	RD-1260	Stop Lever, Tension Arm	1
61	RD-1261	Nut 6 mm (special)	1
62	RD-1262	"E" Ring 4 mm	1
63	RD-1263	Plate, Printed Board Mounting	1
64	RD-1264	Printed Board, Reverse Pin	1
65	RD-1265	Reverse Pin	1
66	RD-1266	Nut 2.3 mm	1
67	RD-1267	Prop, Reverse Tape Guide	1
68	RD-1268	Reverse, Tape Guide	1
69	RD-1269	Set Screw, 4 x 5 mm	1
70	RD-1270	Nut 3 mm	1
71	RD-1271	Cushion, Rubber Sleeve	1
72	RD-1272	Screw, round head 3 x 4 mm	3
73	RD-1273	Screw, pan head 3 x 8 mm	1
74	RD-1274	Screw, counter sunk head 3 x 6 mm	1

**STABILIZER BLOCK (RD-1300)**

Ref. No.	Parts No.	Nomenclature	Quantity
	RD-1300	Stabilizer Assembly Complete	1
75	RD-1301	Stabilizer Shaft	1
76	RD-1302	"E" Ring 7 mm	1
77	RD-1303	SVS Washer 15.8 x 0.25 mm	1
78	RD-1304	Stopper Ring (Bearing Mount)	1
79	RD-1305	Bearing 608VVC2EL	2
80	RD-1306	Spacer Collar	1

PARTS TABLE 2

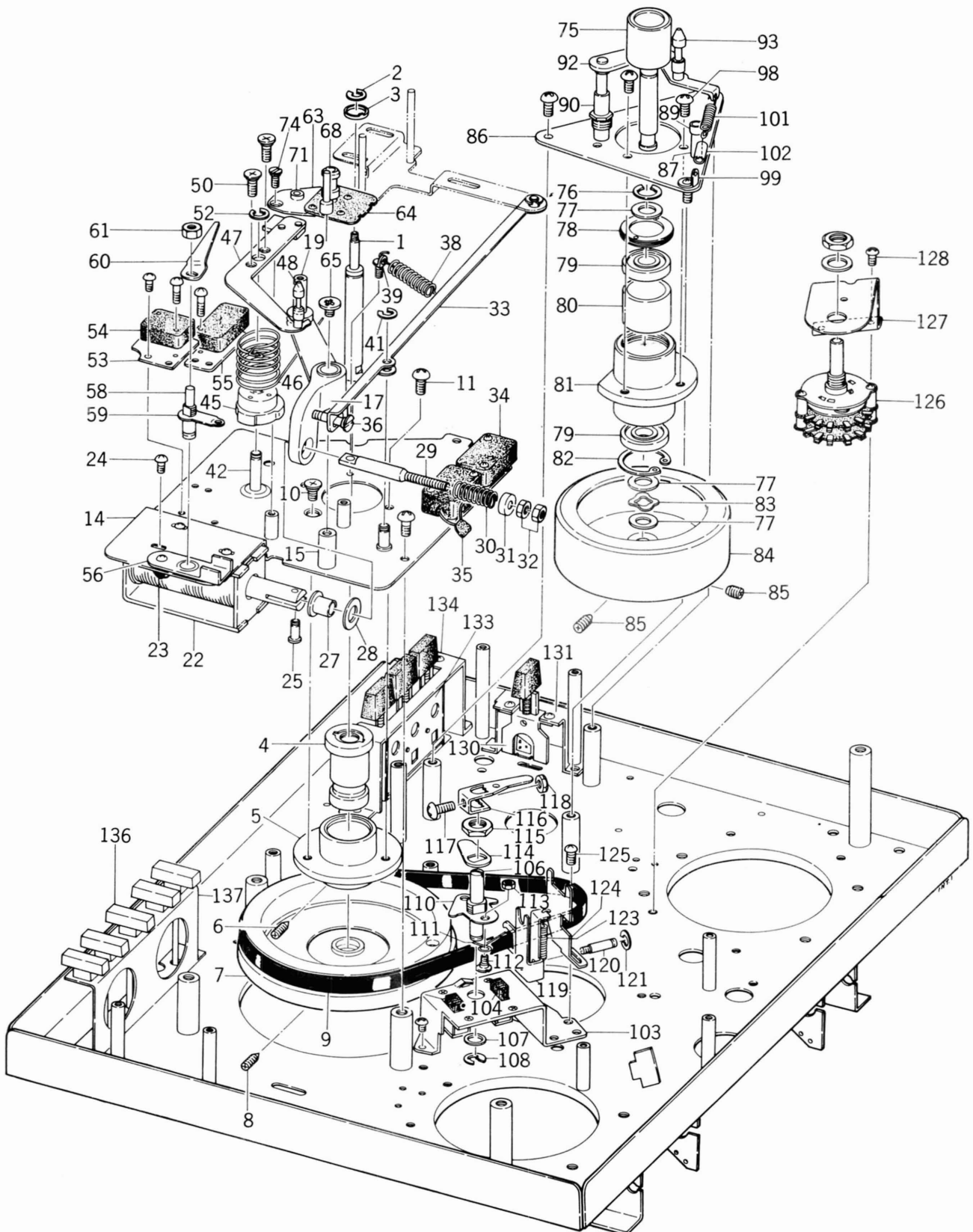

PARTS TABLE 2

Ref. No.	Parts No.	Nomenclature	Quantity	Ref. No.	Parts No.	Nomenclature	Quantity
81	RD-1307	Bearing Case	1	120	RD-1718	Shaft, Cycle Change Lever	1
82	RD-1308	"C" Ring 22 mm (Bearing Hold)	1	121	RD-1719	"C" Ring	1
83	RD-1309	Spring Washer	1	122	RD-1720	Nut 3 mm, Shaft Mounting	1
84	RD-1310	Stabilizer Wheel	1	123	RD-1721	Spring, Cycle Change Lever	1
85	RD-1311	Set Screw 5 x 5 mm	2	124	RD-1722	Stopper Metal (Cycle Change Lever)	1
86	RD-1312	Plate, Stabilizer Mounting	1	125	RD-1723	Screw, binding head 3 x 5 mm	1
87	RD-1313	Prop, Stopper for Tension Arm	1	<b>MECHANISM CHASSIS (RD-2000)</b>			
88	RD-1314	Screw, binding head	1	126	RD-2001	Magnetic Brake Control Switch (Y263)	1
89	RD-1315	Rubber Cushion	1	127	RD-2002	Bracket, Brake Control Switch Mounting	1
90	RD-1316	Bearing, Tension Arm	1	128	RD-2003	Screw, binding head 3 x 5 mm	1
91	RD-1317	Nut 9 mm	1	129	RD-2004	Silicon Diode 10D4	1
92	RD-1318	Tension Arm	1	130	RD-2005	Power Switch Complete UEH12BF00-1	1
93	RD-1319	Tape Guide C, Tension Arm	1	131	RD-2006	Bracket, Power Switch Mounting	1
94	RD-1320	Metal Washer 8 x 0.2 mm	1	132	RD-2007	Spark Quencher (0.033 $\mu$ F + 120 $\Omega$ 500V)	1
95	RD-1321	Screw, counter sunk head 3 x 5 mm	1	133	RD-2008	Speed Selector Switch Assembly Complete (RD-139B)	1
96	RD-1322	Metal Washer, 7.8 x 0.5 mm	1	134	RD-2009	Bracket, Speed Selector Switch Mounting	1
97	RD-1323	Nut 3 mm	1	135	RD-2010	Screw, pan head 3 x 5 mm	2
98	RD-1324	Screw, pan head 4 x 8 mm	3	136	RD-2018	Knob, Function Switch	5
99	RD-1325	Lug Plate 4 mm	1	137	RD-2019	Bracket, Knob Mounting	1
100	RD-1326	Screw, pan head 4 x 8 mm	3				
101	RD-1327	Spring, Tension Arm	1				
102	RD-1328	Nylon Tube 5 x 18 mm (for Tension Spring)	1				
<b>CYCLE CHANGE BLOCK (RD-1700)</b>							
	RD-1700	Cycle Change Block Assembly Complete	1				
103	RD-1701	Bracket, Cycle Change Switch Mounting	1				
104	RD-1702	Slide Switch 11A-1053A	2				
105	RD-1703	Screw, counter sunk head No.4-40 x 6 (inch size)	4				
106	RD-1704	Shaft, Cycle Change Switch	1				
107	RD-1705	Nylon Washer 10 x 1 mm	1				
108	RD-1706	"U" Ring 4 mm	1				
109	RD-1707	Steel Ball 4 mm	1				
110	RD-1708	Plate, Cycle Change Switch	1				
111	RD-1709	Spring, Plate Activating	1				
112	RD-1710	Screw, flat head 3 x 6 mm (Spring Mount)	1				
113	RD-1711	Nut 3 mm	1				
114	RD-1712	Bar Spring (Steel Ball Stopper)	1				
115	RD-1713	Nut	1				
116	RD-1714	Shifter Lever, Cycle Change	1				
117	RD-1715	Screw, pan head 4 x 8 mm	1				
118	RD-1716	Nut 4 mm	1				
119	RD-1717	Cycle Change Lever	1				

PARTS TABLE 3

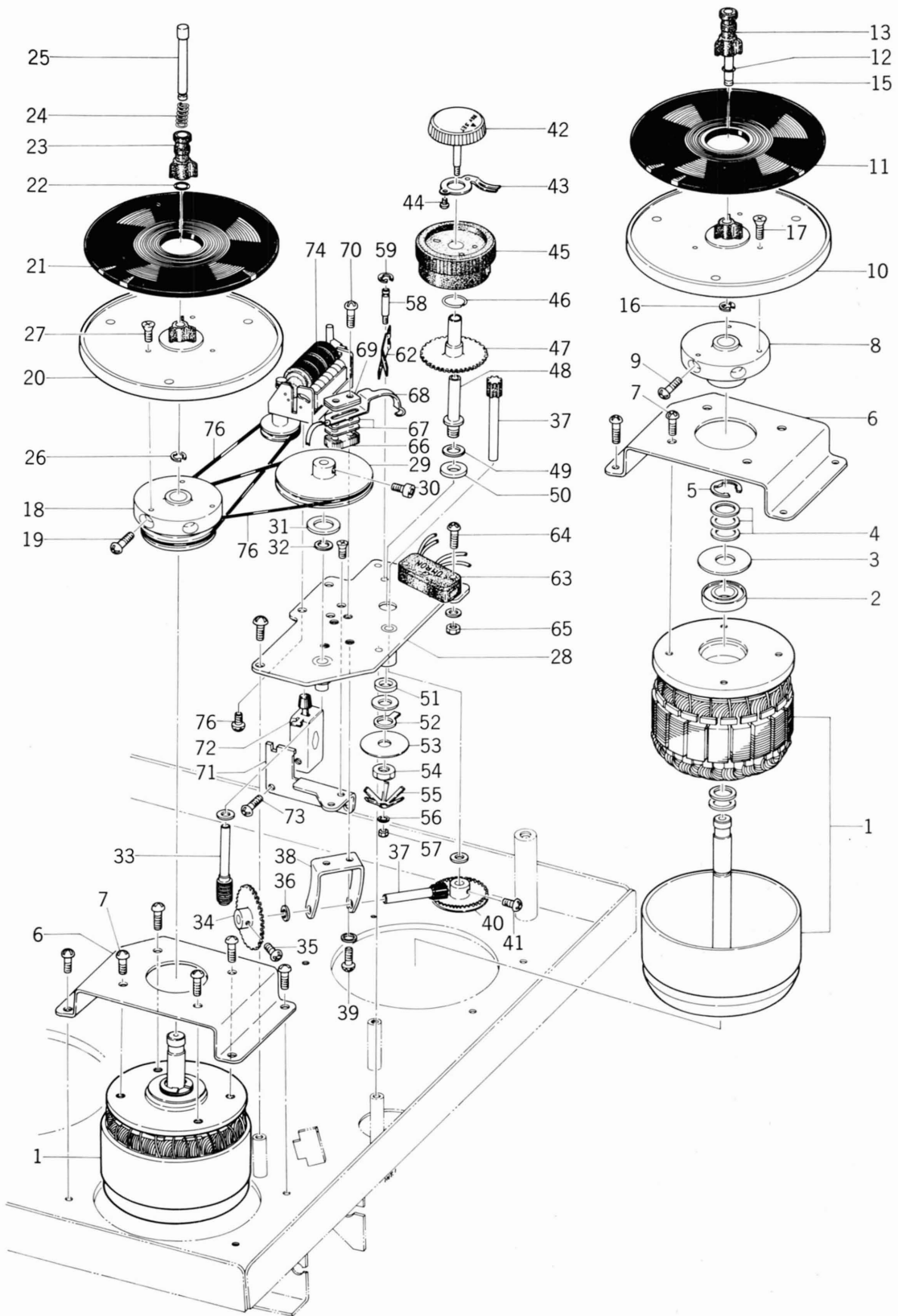

## PARTS TABLE 3

REEL MOTOR & REEL TABLE BLOCK  
(RD-1400)

Ref. No.	Parts No.	Nomenclature	Quantity
	RD-1400	Reel Motor Assembly Complete (24XO)	2
1	RD-1401	Reel Motor	1
2	RD-1402	Bearing 608VVC2EL	1
3	RD-1403	Nylon Washer 24 x 2 mm	1
4	RD-1404	Bronze Washer 13 x 0.1 mm	1~3
5	RD-1405	"E" Ring 7 mm (Rotor Shaft Hold)	1
6	RD-1406	Plate, Motor Mounting	1
7	RD-1407	Screw, pan head 4 x 6 mm	4
	RD-1408	Supply Reel Table Complete	1
8	RD-1409	Pulley, Supply Reel	1
9	RD-1410	Screw, pan head 4 x 8 mm	2
10	RD-1411	Reel Table	1
11	RD-1412	Rubber Plate, Reel Table	1
12	RD-1413	Rubber Ring 6 mm	1
13	RD-1414	Reel Retainer	1
14	RD-1415	Spring, Reel Retainer Shaft	1
15	RD-1416	Shaft, Reel Retainer	1
16	RD-1417	"E" Ring 1.9 mm	1
17	RD-1418	Screw, counter sunk head 3 x 10 mm	3
	RD-1419	Take-up Reel Complete	1
18	RD-1420	Pulley, Take-up Reel Complete	1
19	RD-1421	Screw, pan head 4 x 8 mm (Pulley Mounting)	2
20	RD-1422	Reel Table	1
21	RD-1423	Rubber Plate, Reel Table	1
22	RD-1424	Rubber Ring 6 mm	1
23	RD-1425	Reel Retainer	1
24	RD-1426	Spring, Reel Retainer Shaft	1
25	RD-1427	Shaft, Reel Retainer	1
26	RD-1428	"E" Ring 1.9 mm	1
27	RD-1429	Screw, counter sunk head 3 x 10 mm	3

## REVERSE MECHANISM BLOCK (RD-1600)

	RD-1600	Reverse Mechanism Assembly Complete	1
28	RD-1601	Chassis, Reverse Mechanism	1
29	RD-1602	Pulley (Belt Driven)	1
30	RD-1603	Screw, Cylinder Head 3 x 5 mm (Pulley Mounting)	1
31	RD-1604	Felt Washer 13 x 1 mm	1
32	RD-1605	Nylon Washer 7 x 0.25 mm	2
33	RD-1606	Worm Gear with Shaft	1
34	RD-1607	Spur Gear	1
35	RD-1608	Screw, round head 3 x 4 mm	1
36	RD-1609	Nylon Washer 7 x 0.025 mm	2
37	RD-1610	Pinion Gear with Shaft	2

Ref. No.	Parts No.	Nomenclature	Quantity
38	RD-1611	Bracket, Gear Mounting	1
39	RD-1612	Screw, round head 3 x 4 mm	2
40	RD-1613	Link Gear	1
41	RD-1614	Screw, round head 3 x 4 mm	1
42	RD-1615	Reverse Set Dial	1
43	RD-1616	Contact Pin (Reverse)	1
44	RD-1617	Screw, binding head 2.3 x 3 mm	2
45	RD-1618	Tape Count Meter Dial	1
46	RD-1619	Metal Ring (for Tape Count Meter)	1
47	RD-1620	Spur Gear	1
48	RD-1621	Dial Shaft	1
49	RD-1622	Metal Washer 13 x 0.3 mm	1
50	RD-1623	Insulator (Nylon Bush)	1
51	RD-1624	Nylon Washer 10.3 x 0.5 mm	1
52	RD-1625	Lug Terminal	1
53	RD-1626	Metal Washer 22 x 0.5 mm	1
54	RD-1727	Nut 6 mm	1
55	RD-1628	Clutch Spring	1
56	RD-1629	Toothed Lock Washer 3 mm	1
57	RD-1630	Nut 2.3 mm	1
58	RD-1631	Prop, (Actuator Mounting)	1
59	RD-1632	"E" Ring 1.9 mm	1
60	RD-1633	Toothed Lock Washer 3 mm	1
61	RD-1634	Nut 2.3 mm	1
62	RD-1635	Actuator (Micro Switch)	1
63	RD-1636	Micro Switch V-1A44	1
64	RD-1637	Screw, round head 3 x 15 mm	2
65	RD-1638	Nut 3 mm	2
66	RD-1639	Insulator (Contact-maker)	1
67	RD-1640	Spacer, (Contact-maker)	3
68	RD-1641	Contact-maker (metal)	1
69	RD-1642	Metal Plate	1
70	RD-1643	Screw, round head 3 x 15 mm	2
71	RD-1644	Bracket, Reverse-o-matic Set Switch Mounting	1
72	RD-1645	Reverse-O-matic Set Switch (UEG-22V)	1
73	RD-1646	Screw, binding head 3 x 5 mm	1
74	RD-1747	Tape Counter Complete	1
75	RD-1648	Screw, binding head 3 x 5 mm	2
76	RD-1649	Counter Belt (75 mm)	2

PARTS TABLE 4

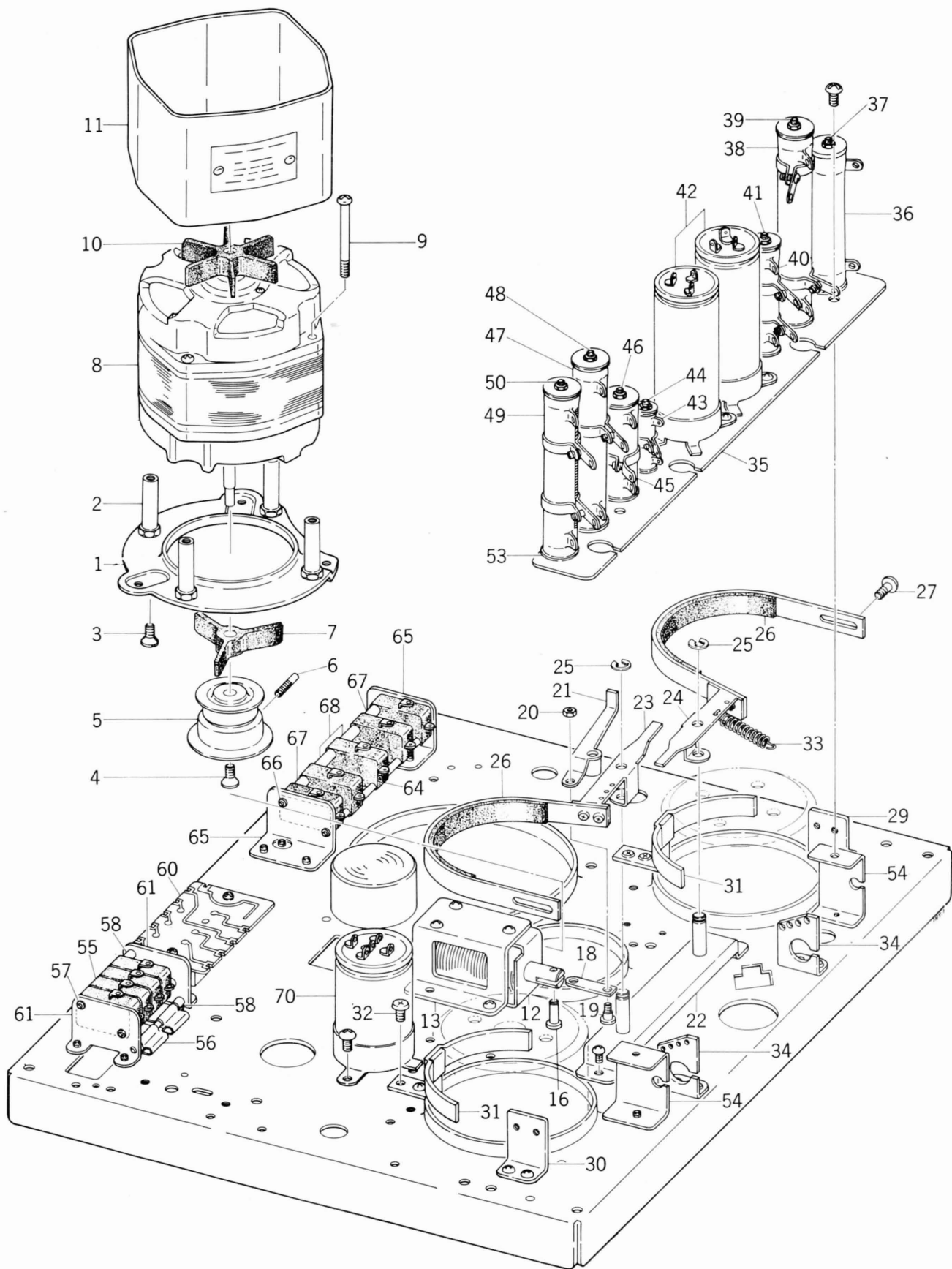



## PARTS TABLE 4

## MAIN MOTOR BLOCK (RD-1500)

Ref. No.	Parts No.	Nomenclature	Quantity	Ref. No.	Parts No.	Nomenclature	Quantity
				41	RD-1907	Screw, round head 3 x 60 mm	1
	RD-1500	Main Motor Assembly Complete (16X)	1	42	RD-1908	Metallized Paper Capacitor (Lug Tubular Type)	2
1	RD-1501	Plate, Motor Mounting	1	43	RD-1909	Resistor, 1K $\Omega$ (K) 5H	1
2	RD-1502	Prop, Motor Mounting	4	44	RD-1910	Screw, round head 3 x 50 mm	1
3	RD-1503	Screw, counter sunk head 4 x 10 mm	4	45	RD-1911	Resistor, 1.7K $\Omega$ (K) 20H	1
4	RD-1504	Screw, oval counter sunk head 3 x 15 mm	1	46	RD-1912	Screw, round head 3 x 65 mm	1
5	RD-1505	Motor Pulley	1	47	RD-1913	Resistor, 650 $\Omega$ (K) 30H	1
6	RD-1506	Set Screw 3 x 7.5 mm (Motor Pulley Mounting)	1	48	RD-1914	Screw, round head 3 x 85 mm	3
7	RD-1507	Motor Fan (Rubber)	1	49	RD-1915	Resistor, 120 $\Omega$ (K) 30H	1
8	RD-1508	Main Motor	1	50	RD-1916	Screw, round head 3 x 85 mm	3
9	RD-1509	Screw, pan head 4 x 50 mm	4	51	RD-1917	Nut 3 mm	6
10	RD-1510	Motor Fan (Rubber)	1	52	RD-1918	Nut 4 mm	1
11	RD-1511	Shield Case	1	53	RD-1919	Insulation Washer 18 x 1 mm	10

## BRAKE BLOCK (RD-1800)

12	RD-1801	Solenoid SDCM10-C	1	54	RD-1920	Bracket, (Resistor Plate Mounting)	2
13	RD-1802	Bracket, Solenoid Mounting	1	55	RD-2011	Micro Switch V-1A44	4
14	RD-1803	Screw, binding head 3 x 5 mm	3	56	RD-2012	Actuator for Micro Switch	2
15	RD-1804	Diode SL-150	1	57	RD-2013	Shaft 3 x 55 mm (Micro Switch Mounting)	3
16	RD-1805	Connection Pin 3 x 15.5 mm	1	58	RD-2014	Metal Sleeve, Micro Switch Mounting 6 x 7 mm	2
17	RD-1806	"E" Ring 1.9 mm	1	59	RD-2015	"E" Ring 1.9 mm	6
18	RD-1807	Solenoid Ring	1	60	RD-2016	Spurk Quencher Block (RD-150)	1
19	RD-1808	Screw, flat head 3 x mm	1	61	RD-2017	Bracket, Micro Switch Mounting	2
20	RD-1809	Nut 3 mm	1	62	RD-2020	Spring (Function Switch Knob Tension)	5
21	RD-1810	Bracket Lever A	1	63	RD-2021	"E" Ring 3.2 mm	5
22	RD-1811	Bracket, Brake Lever Mounting	1	64	RD-2022	Micro Switch V-1A44 (Function Switch)	5
23	RD-1812	Braker Lever B	1	65	RD-2023	Bracket, Micro Switch Mounting	2
24	RD-1813	Braker Lever C	1	66	RD-2024	Shaft, Micro Switch Mounting 3 x 107 mm	2
25	RD-1814	"C" Ring 2.85 mm	2	67	RD-2025	Metal Sleeve 5 x 8.6 mm	2
26	RD-1815	Brake Band with Felt	2	68	RD-2026	Metal Sleeve 5 x 15.6 mm	2
27	RD-1816	Screw, binding head 3 x 5 mm	8	69	RD-2027	"E" Ring 1.9 mm	4
28	RD-1817	Spring Washer 3 mm	8	70	RD-2027	Metallized Paper Capacitor 2 $\mu$ F + 1 $\mu$ F 250 WV (for Main Motor)	1
29	RD-1818	Bracket A, Brake Band Mounting	1				
30	RD-1819	Bracket B, Brake Band Mounting	1				
31	RD-1820	Bracket, Brake Band Guide	2				
32	RD-1821	Screw	4				
33	RD-1822	Brake Tension Spring	2				
34	RD-1823	Bracket, Brake Spring Mounting	2				

## RESISTOR BLOCK (RD-1900)

	RD-1900	Resistor Block Assembly Complete	1
35	RD-1901	Plate, Resistor and Capacitor Mounting	1
36	RD-1902	Resistor, 1K $\Omega$ (J) 30H	1
37	RD-1903	Screw, round head 3 x 85 mm	3
38	RD-1904	Resistor, 230 $\Omega$ (K) 40H	1
39	RD-1905	Screw, round head 4 x 100 mm	1
40	RD-1906	Resistor, 400 $\Omega$ (K) 15H	1

## SYSTEM CONTROL BLOCK (RD-144)

Ref. No.	Parts No.	Nomenclature	Quantity
	RD-144	System Control Block	1
		<b>Transistor</b>	
1	TR44-1	2SC372	1
2	TR44-2	2SC728	1
		<b>Carbon Resistor with Stopper</b>	
3	R44-2,3	1/4 watt 1K (K)	2
4	R44-4	1/4 watt 6.8K (J)	1
5	R44-8	1/4 watt 10K (K)	1
6	R44-5	1/4 watt 47K (J)	1
7	R44-7	1/4 watt 100K (K)	1
8	R44-6	1/4 watt 680K (K)	1
9	R44-1	Metal Oxide Film Resistor 2W 15K (K)	1
10	R44-9	Wired Resistor 2W 10Ω	1
11	R44-10	Solid Resistor 68K 1/2W	1
		<b>Electrolytic Vertical Mounting Type Capacitor</b>	
12	C44-7	10 μ 25V	1
13	C44-3	10 μ 160V	1
14	C44-1	33 μ 160V	1
15	C44-2	220 μ 160V	1
		<b>Metallized Paper Capacitor Tublar Type</b>	
16	C44-5,6	0.1 μ 250V (M)	2
17	C44-4	0.47 μ 250V (M)	1
18	VR44-1	100K B Variable Resistor	1
19	ZD44-1	Zener Diode RD-24A	1
		<b>Silicon Diode</b>	
20	D44-1,2,5,6,8~12	10D4	9
21	D44-7	10D6	1
22	D44-3,4	SL-150	2
		<b>Relay</b>	
23	RL44-3~13	K6-4P DC 100V	10
24	RL44-2	K6-2P DC 34V	1
25	RL44-1	MHIP-100-0 DC 24V	1
26	SK44-1	Spark-killer Compound 0.1 μ + 120 Ω 250V	12

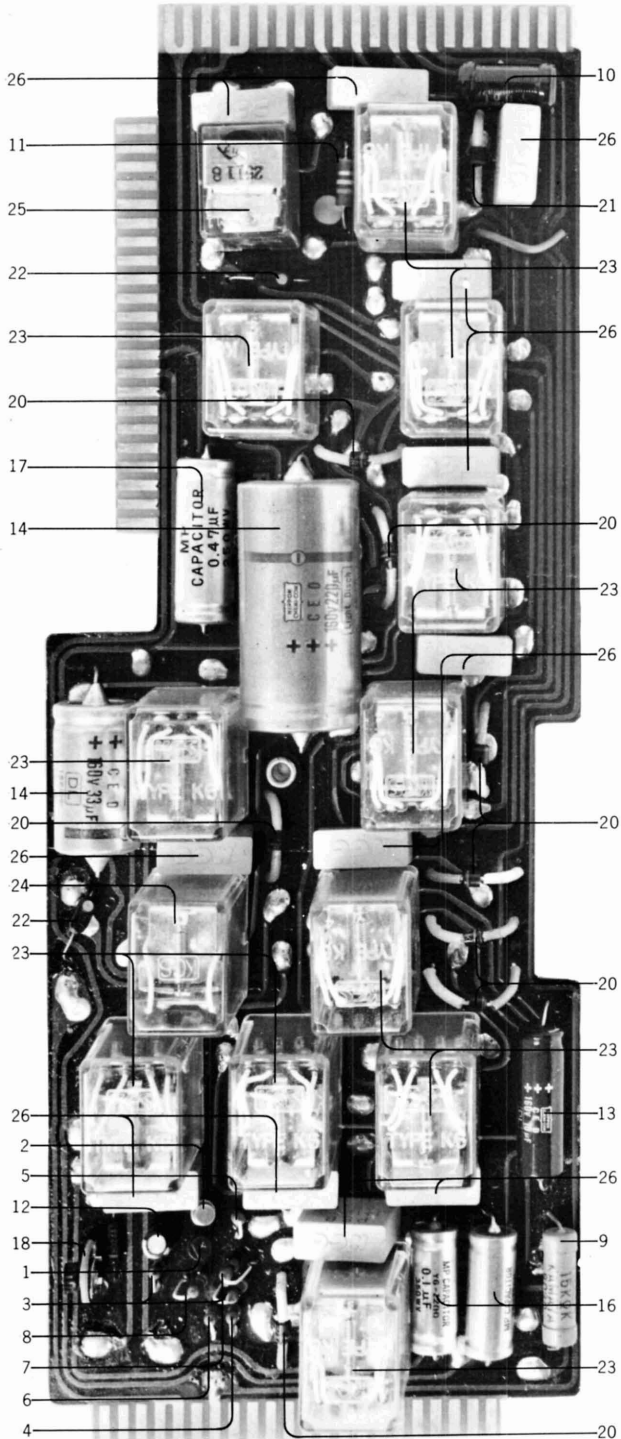

SYSTEM CONTROL BLOCK (RD-144)

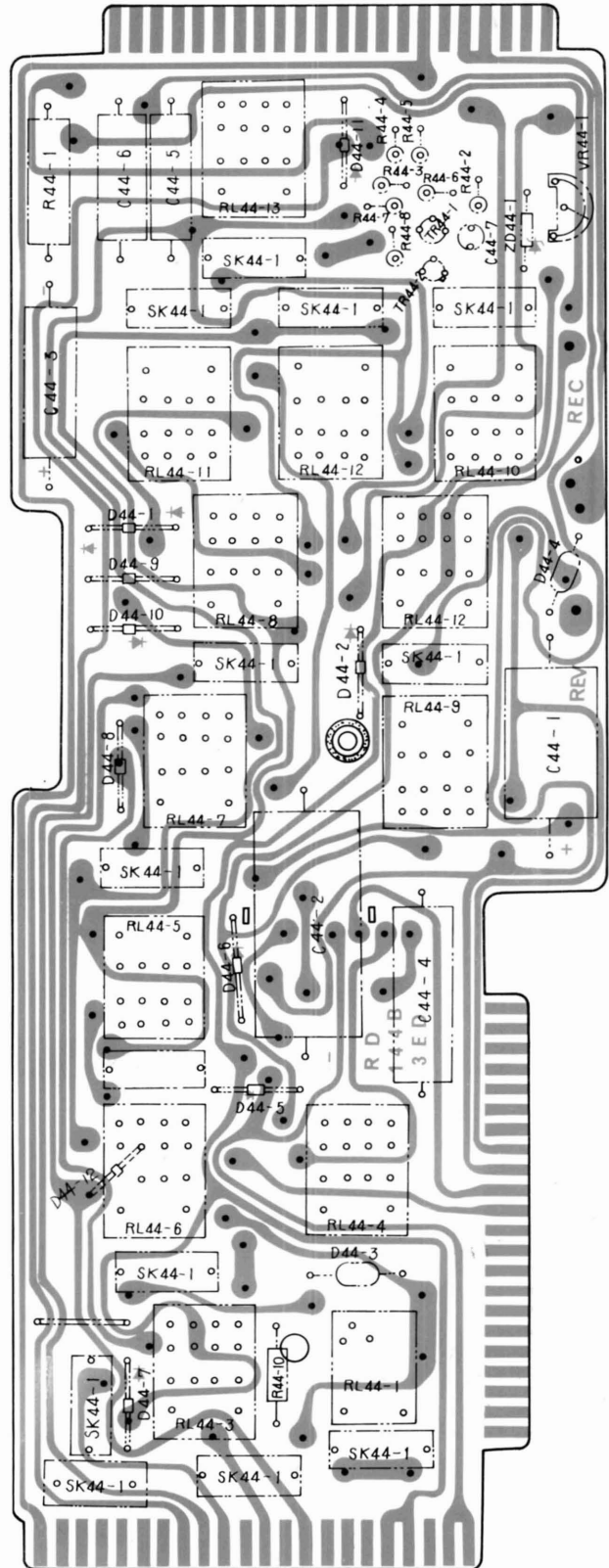
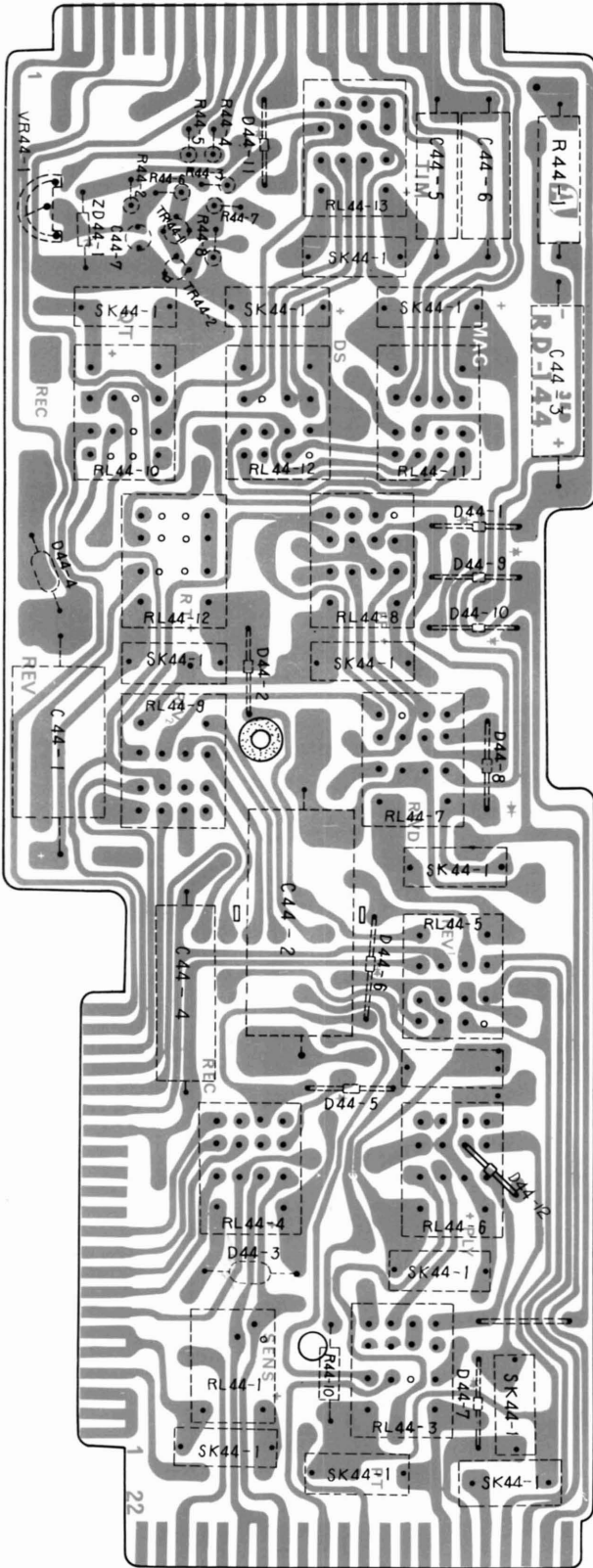

POWER SOURCE BLOCK (RD-2100)

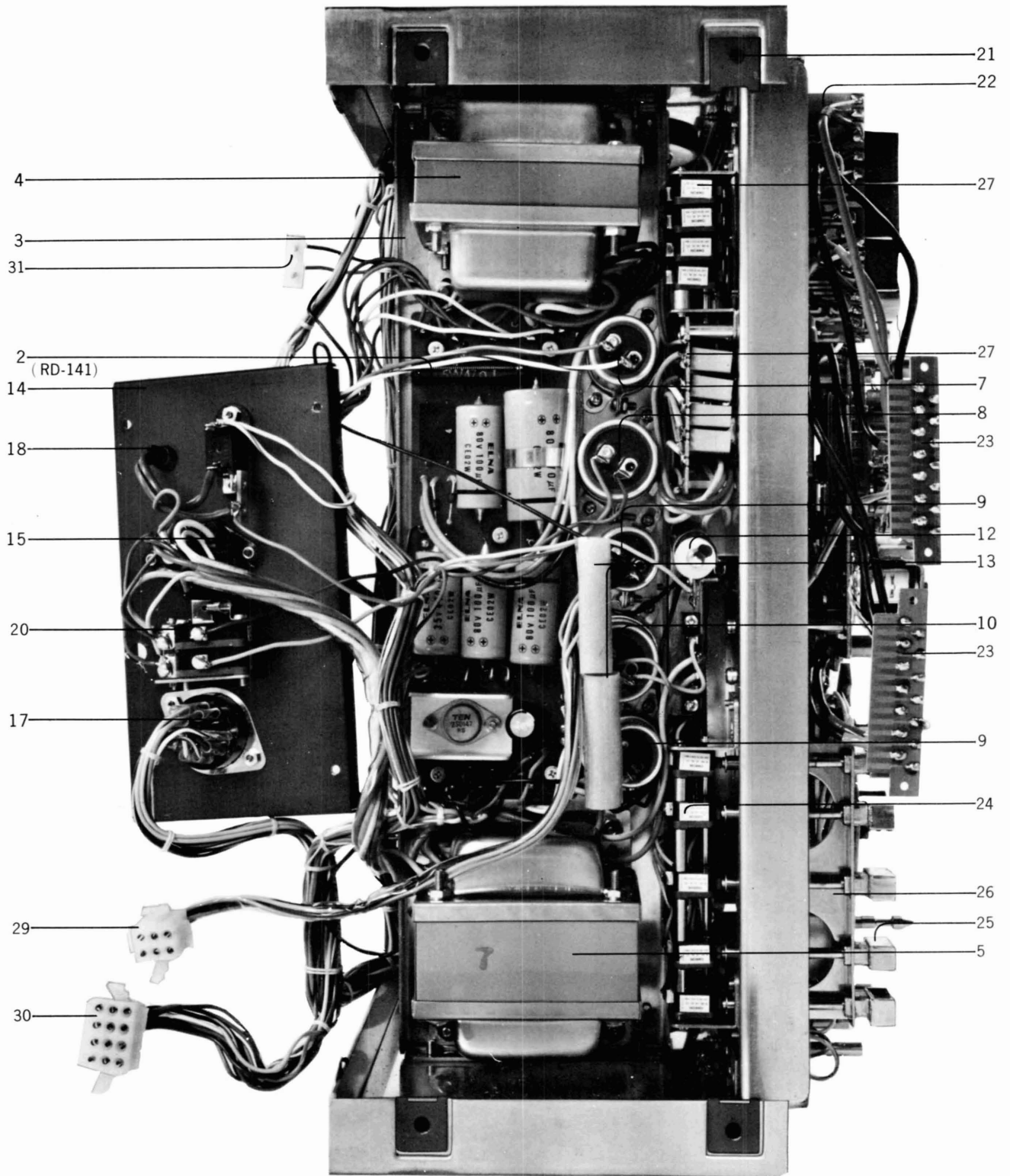

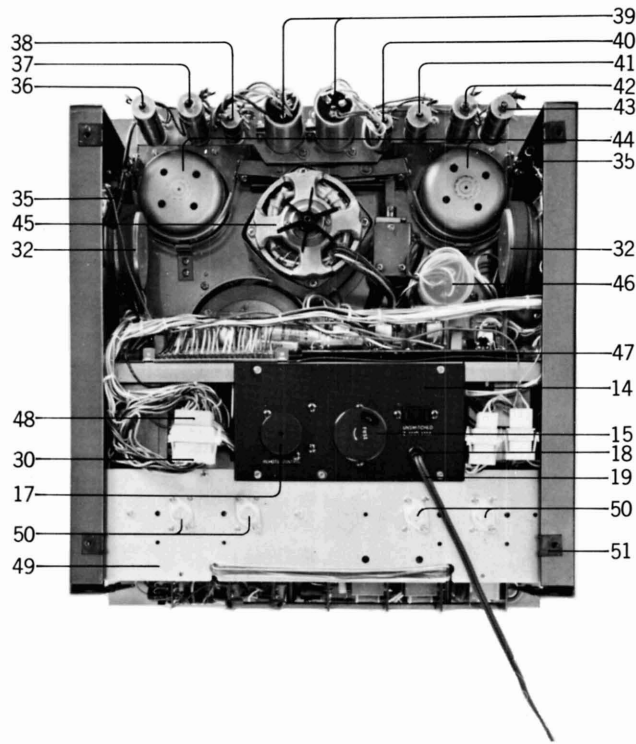

Ref. No.	Parts No.	Nomenclature	Quantity
10	RD-2109	1000 $\mu$ 63V (C55-5)	1
11	RD-2110	Screw, round head 3 x 3 mm	10
12	RD-2111	Wire Wound Fixed Power Resistor 15H 570 $\Omega$	1
13	RD-2112	Wire Wound Resistor 4 W 4 $\Omega$ (J)	2
14	RD-2113	Plate, Voltage Change	1
15	RD-2114	Receptacle Socket (Voltage Selector)	1
16	RD-2115	Screw, truss head 3 x 8 mm	2
17	RD-2116	Socket, Remote Control	1
18	RD-2117	Strain Bushing for AC Cord (SR-2P-1)	1
19	RD-2118	AC Supply Cord	1
20	RD-2119	Micro Switch, Voltage Change (V-1A44)	2
21	RD-2120	Speed Nut	8
22	RD-2008	Speed Selector Switch Assy. Comp. (RD-139B)	1
23	RD-1182	Printed Plug 14P	2
24	RD-2022	Micro Switch (V-1A44)	5
25	RD-2018	Knob, Function Switch	5
26	RD-2019	Bracket, Knob Mounting	1
27	RD-2011	Micro Switch (V-1A44)	4
28	RD-2016	Spark Quencher Block (RD-150)	1
29	RD-2121	6P Socket	1
30	RD-2122	12P Socket	1
31	RD-2123	3P Socket	1
32	RD-2124	Speaker	2
33	RD-2126	Screw, binding head 3 x 12 mm	8
34	RD-2127	Lug Plate KPL1	2
35	RD-2128	Wire wound Resistor 3W 16 $\Omega$	2
36	RD-1902	Resistor, 30H 1K (J)	1
37	RD-1904	Resistor, 40H 230 $\Omega$ (K)	1
38	RD-1906	Resistor, 15H 400 $\Omega$ (K)	1
39	RD-1908	Metalized Paper Capacitor (Lug Tublar Type)	2
40	RD-1909	Resistor, 5H 1K (K)	1
41	RD-1911	Resistor, 20H 1.7K (K)	1
42	RD-1913	Resistor, 30H 650 $\Omega$ (K)	1
43	RD-1915	Resistor 30H 120 $\Omega$ (K)	1
44	RD-1400	Reel Motor Assy. Comp. (24XO)	2
45	RD-1500	Main Motor Assy. Comp. (16X)	1
46	RD-2028	Metalized Paper Capacitor 2 $\mu$ F + 1 $\mu$ F 250V	1
47	RD-144	System Control Block	1
48	RD-2341	12P Plug	1
49	RD-2331	Plate, Heat Sink	1
50	RD-2329	Transistor 2SD-130R	4
51	RD-2120	Speed Nut	8
52	RD-212	Plate, Diode Mounting	1
53	RD-2122	Screw, binding head 3 x 5 mm	2
54	RD-2123	Silicon Diode 5B2	1
55	RD-2124	Screw, binding head 3 x 8 mm	2

### POWER SOURCE BLOCK (RD-2100)

Ref. No.	Parts No.	Nomenclature	Quantity
	RD-2100	Power Source Assembly Complete	1
1	RD-2101	Power Source Chassis Assy. Comp.	1
2	RD-141	Power Source Printed Board Complete	1
3	RD-2102	Chassis, Power Source	1
4	RD-2103	Power Transformer (RD-T1)	1
5	RD-2104	Power Transformer (RD-T3)	1
6	RD-2105	Screw, pan head 4 x 8 mm	8
7	RD-2106	Electrolytic Capacitor 1000 $\mu$ 50V (C55-1)	1
8	RD-2107	Electrolytic Capacitor 220 $\mu$ 160V (C55-2)	1
9	RD-2108	Electrolytic Capacitor 1000 $\mu$ 35V (C55-3,4)	2

# POWER SOURCE PRINTED BOARD (RD-141)

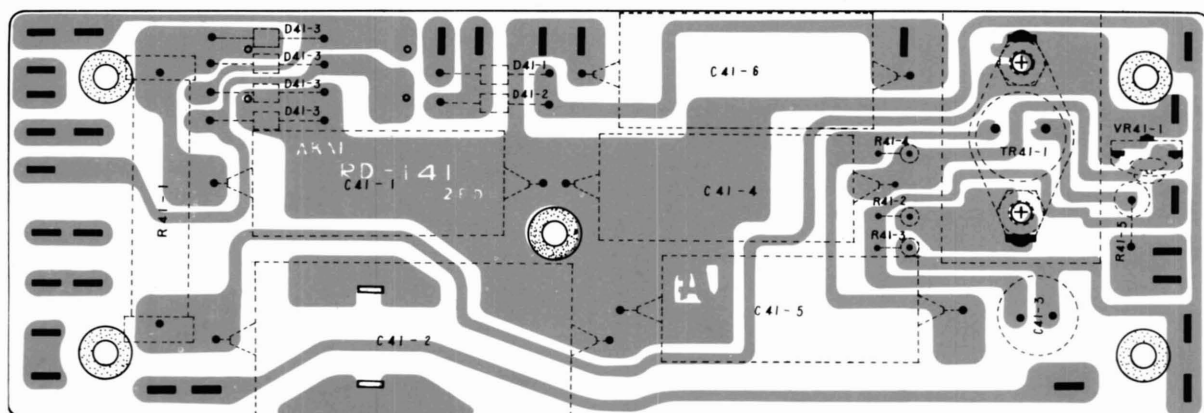
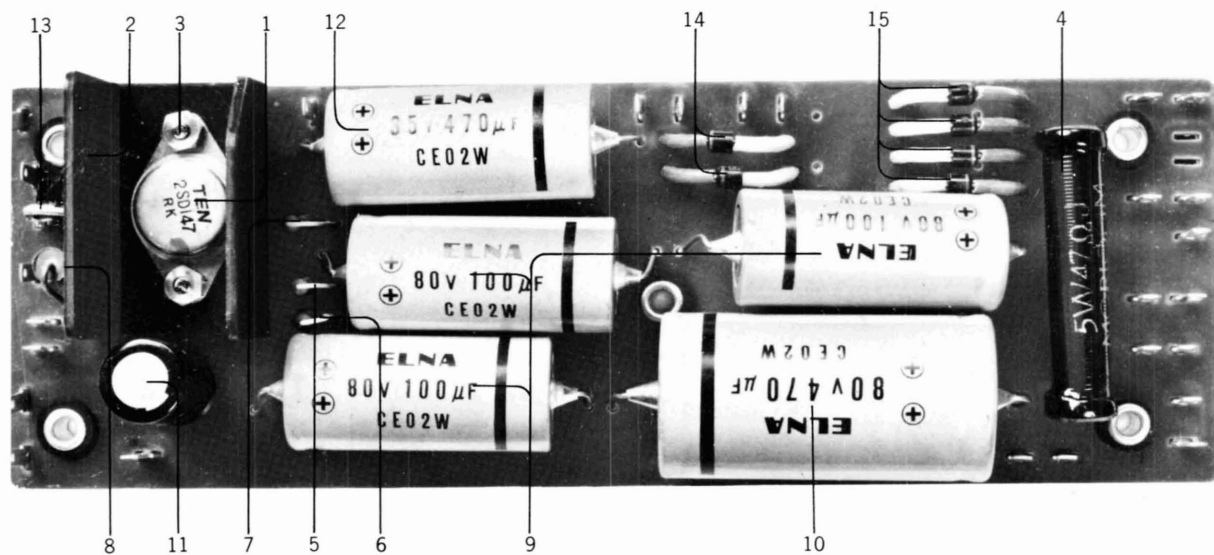

# POWER SOURCE PRINTED BOARD (RD-141)

Ref. No.	Parts No.	Nomenclature	Quantity	Ref. No.	Parts No.	Nomenclature	Quantity
	RD-141	Power Source Printed Board Complete	1				
1	TR41-1	Transistor 2SD147	1	9	C41-1,4,5	Electrolytic, Tubular Type Capacitor 100 μ 80V	3
2	H41-1	Transistor Cooler for 2SD147	1	10	C41-2	470 μ 80V	1
3	S41-1	Screw, binding head 3 x 8 mm	2	11	C41-3	100 μ 50V	1
4	R41-1	Wire wound resistor 5W 47 Ω	1	12	C41-6	470 μ 35V	1
		<b>Carbon Resistor with stopper</b>		13	VR41-1	5KB Semi-variable Resistor	1
5	R41-2	1/4 watt 4.7K (K)	1	14	D41-1,2	Silicon Diode SW-05-02	2
6	R41-3	1/4 watt 5.6K (K)	1	15	D41-3	10D4	4
7	R41-4	1/4 watt 2.7K (K)	1		S41-2	Screw, flat head 3 x 12mm	5
8	R41-5	Solid Resistor 1 watt 10 Ω (K)	1				

OSC PRINTED  
CIRCUIT BOARD  
(RD-530)

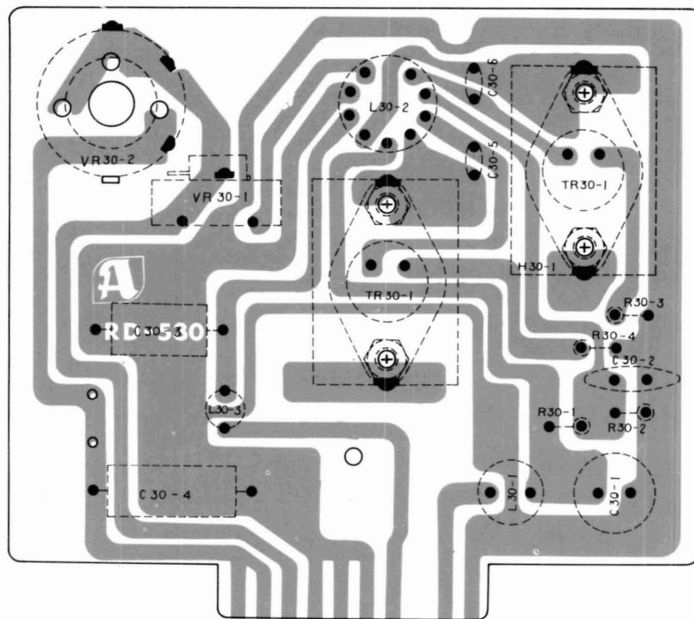
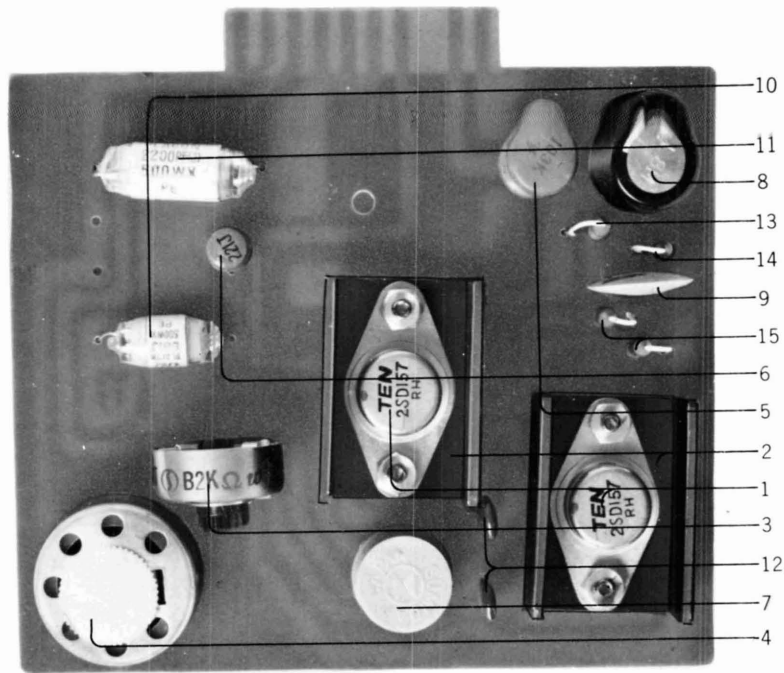

OSC PRINTED CIRCUIT BOARD (RD-530)

Ref. No.	Parts No.	Nomenclature	Quantity	Ref. No.	Parts No.	Nomenclature	Quantity
	RD-530	OSC Printed Circuit Board Complete	1	9	C30-2	Ceramic Condenser vertical mounting type 0.1 $\mu$ 50V	1
1	TR30-1	Transistor 2SD157	2	10	C30-3	Plastic Film Condenser 680P 500V	1
2	H30-1	Transistor Cooler for 2SD157	2	11	C30-4	2200P 500V	1
		<b>Wire wound semi-variable Resistor</b>		12	C30-5,6	Mylar Condenser, tublar type 0.0056 $\mu$ (K) 100V	2
3	VR30-1	1.5W 2KB WR185-2K(PH)	1	13	R30-1	Carbon Resistor with Stopper 1/4 watt 22K	1
4	VR30-2	1.5W 5KB WR241-5K (PVB)	1	14	R30-2	1/4 watt 1K	1
		<b>Inductive Coil</b>		15	R30-3,4	1/4 watt 10 $\Omega$	2
5	L30-1	FL11H 10mH	1				
6	L30-3	FL-7H 220 $\mu$ H	1				
7	L30-2	OSC Coil MC-152	1				
8	C30-1	Electrolytic Capacitor, vertical mounting type 100 $\mu$ 50V	1				

AUTOMATIC DUST MINDER PRINTED CIRCUIT BOARD (RD-271)

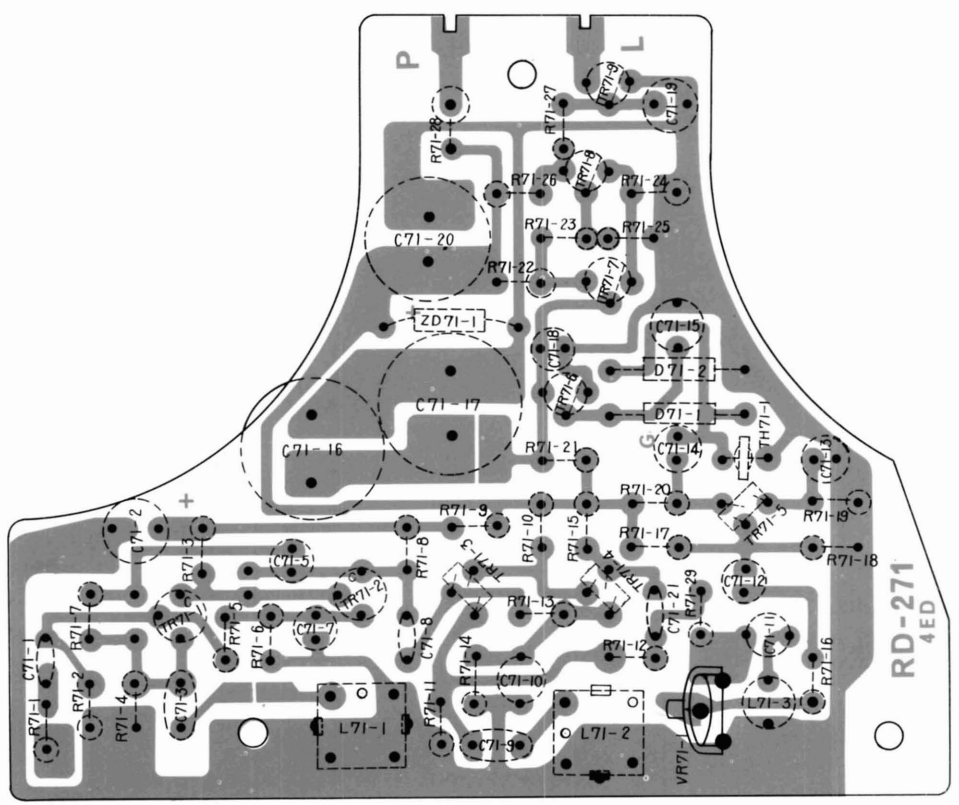
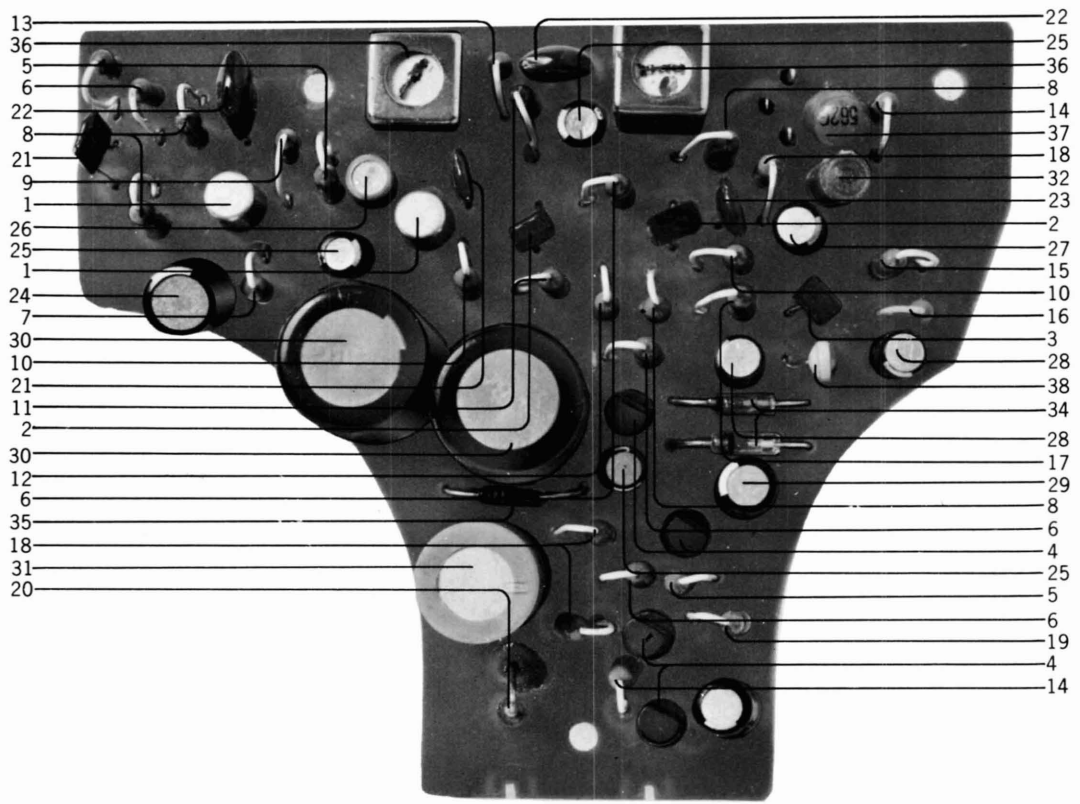



## AUTOMATIC DUST MINDER PRINTED CIRCUIT BOARD (RD-271)

Ref. No.	Parts No.	Nomenclature	Quantity
	RD-271	<b>Automatic Dust Minder Printed Circuit Board Complete</b>	1
		<b>Transistor</b>	
1	TR71-1,2	2SC650 (B)	2
2	TR71-3,4	2SC458 LG(B)	2
3	TR71-5	2SC458 (B)	1
4	TR71-6~9	2SC372	4
		<b>Carbon Resistor with Stopper</b>	
5	R71-1,6,25	1/4 watt 10K (K)	2
6	R71-2,13, 21,23	1/4 watt 47K (K)	4
7	R71-3	1/4 watt 100K (K)	1
8	R71-4,7, 12,15	1/4 watt 6.8K (K)	4
9	R71-5	1/4 watt 68K (K)	1
10	R71-8,17	1/4 watt 15K (K)	2
11	R71-9,14	1/4 watt 1K (K)	2
12	R71-10	1/4 watt 22K (K)	1
13	R71-11	1/4 watt 330 $\Omega$	1
14	R71-16,27	1/4 watt 3.3K (K)	2
15	R71-18	1/4 watt 5.7K (K)	1
16	R71-19	1/4 watt 470 $\Omega$ (K)	1
17	R71-20	1/4 watt 1.5K (K)	1
18	R71-22, 26,29	1/4 watt 2.2K (K)	3
19	R71-24	1/4 watt 47 $\Omega$ (K)	1
20	R71-28	<b>Solid Resistor</b> 1/2 watt 470 $\Omega$ (K)	1
		<b>Mylar Condenser, vertical mounting type</b>	
21	C71-1,8	0.01 $\mu$ 50V	2
22	C71-3,9	0.033 $\mu$ 50V	2
23	C71-21	0.022 $\mu$ 50V	1
		<b>Electrolytic Capacitor, vertical mounting type</b>	
24	C71-2	47 $\mu$ 16V	1
25	C71-5,10,18	10 $\mu$ 10V	3
26	C71-7	1 $\mu$ 17V	1
27	C71-12	1 $\mu$ 10V	1
28	C71-13,14	1 $\mu$ 16V	2
29	C71-15,19	33 $\mu$ 3.15V	2
30	C71-16,17	1000 $\mu$ 3.15V	2
31	C71-20	220 $\mu$ 16V	1
32	C71-11	<b>Styrol Capacitor</b> 470P 50V	1
33	VR71-1	10K (B) Semi-variable Resistor	1
34	D71-1	<b>Germanium Diode</b> IN34A	2
35	ZD71-1	Zener Diode IN759A	1
36	L71-1,2	DM Coil, 100mH	2
37	L71-3	Inductive Coil FL-7H 5.6mH	1
38	TH71-1	Thermister 41D26	1

PLAYBACK PRINTED CIRCUIT BOARD (RD-529)

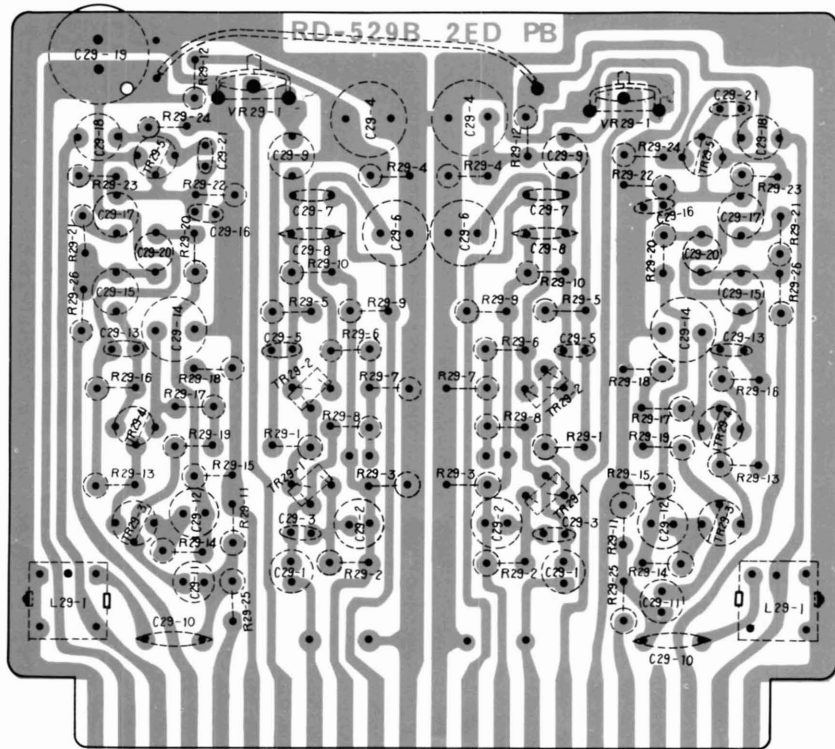
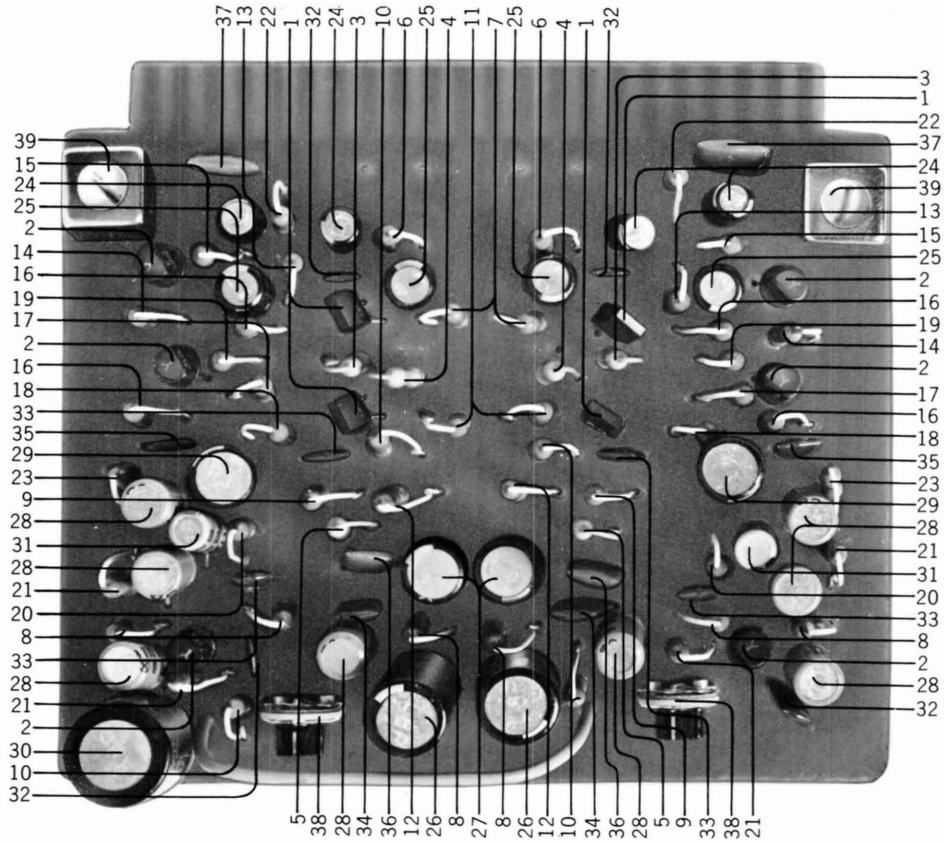

## PLAYBACK PRINTED CIRCUIT BOARD (RD-529)

Ref. No.	Parts No.	Nomenclature	Quantity
	RD-529	Playback Printed Circuit Board Complete	1
		<b>Transistor</b>	
1	TR29-1,2	2SC458LG ©	4
2	TR29-3,4,5	2SC372	6
		<b>Carbon Resistor with Stopper (Noiseless)</b>	
3	R29-1	1/4 watt 180K	2
4	R29-8	1/4 watt 270K	2
5	R29-10	1/4 watt 220K	2
		<b>Carbon Resistor with Stopper</b>	
6	R29-2	1/4 watt 10K	2
7	R29-3	1/4 watt 270 Ω	2
8	R29-4,22, 23	1/4 watt 100K	6
9	R29-5	1/4 watt 18K	2
10	R29-6,12	1/4 watt 6.8K	4
11	R29-7	1/4 watt 3.9K	2
12	R29-9	1/4 watt 12K	2
13	R29-11	1/4 watt 47K	2
14	R29-13	1/4 watt 15K	2
15	R29-14	1/4 watt 220 Ω	2
16	R29-15,16	1/4 watt 1.5K	4
17	R29-17	1/4 watt 180 Ω	2
18	R29-18	1/4 watt 390 Ω	2
19	R29-19	1/4 watt 68K	2
20	R29-20	1/4 watt 6.2K	2
21	R29-21,24	1/4 watt 3.3K	4
22	R29-25	1/4 watt 2.2K	2
23	R29-26	1/4 watt 1K	2
		<b>Electrolytic Capacitor, Vertical Mounting Type</b>	
24	C29-1,11	10 μ 10V	4
25	C29-2,12	22 μ 6.3V	4
26	C29-4	100 μ 25V	2
27	C29-6	47 μ 6.3V	2
28	C29-9,15, 17,18	10 μ 25V	8
29	C29-14	100 μ 10V	2
30	C29-19	100 μ 50V	1
31	C29-20	0.001 μ 50V	2
		<b>Mylar Condenser Vertical Mounting Type</b>	
32	C29-3,21	0.001 μ 50V	4
33	C29-5,16	0.0022 μ 50V	4
34	C29-7	0.01 μ 50V (J)	2
35	C29-13	0.01 μ 50V	2
		<b>Minature Film Mica Condenser</b>	
36	C29-8	150P 50V	2
37	C29-10	270P 50V	2
38	VR29-1	50KB Semi-variable Resistor	2
39	L29-1	DM Coil 100mH (J) (Inductive Coil FL9H 10mH (J))	2

RECORD PRINTED CIRCUIT BOARD (RD-528)

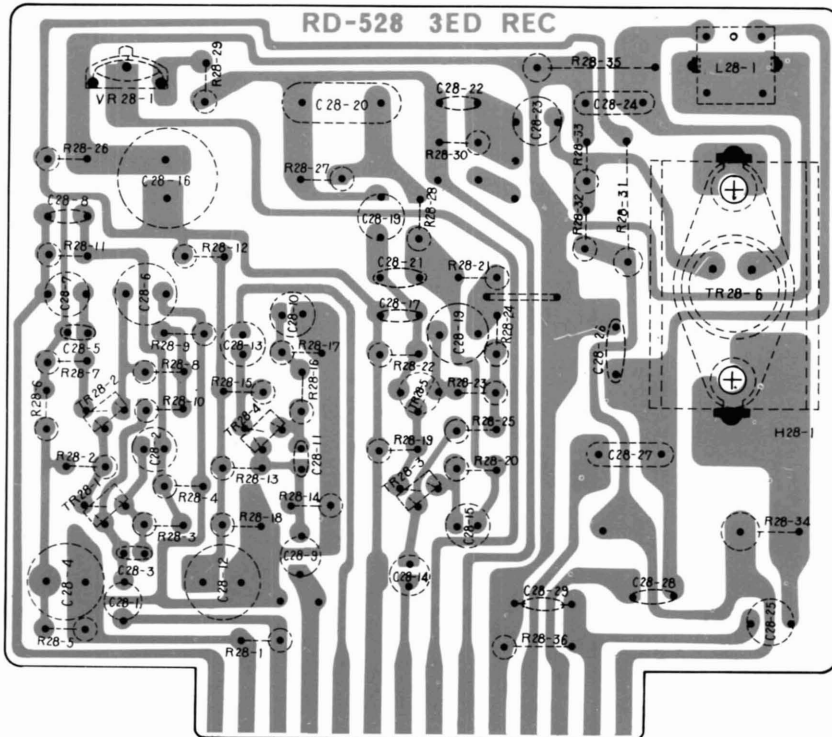
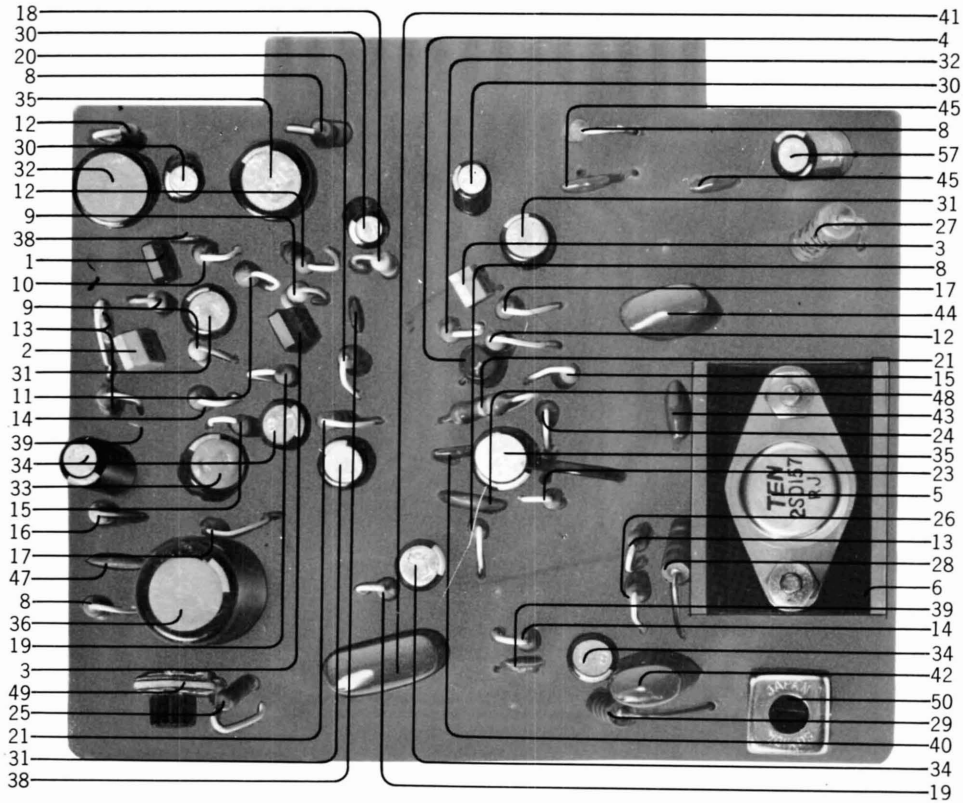

## RECORD PRINTED CIRCUIT BOARD (RD-528)

Ref. No.	Parts No.	Nomenclature	Quantity	Ref. No.	Parts No.	Nomenclature	Quantity
	RD-528	Record Printed Circuit Board Complete	1	50	L28-1	Inductor Coil P-10L	1
		Transistor					
1	TR28-1	2SC-458LG(B)(C)	1				
2	TD28-2	2SC-458(C)	1				
3	TR28-3,4	2SC-458(B)	2				
4	TR28-5	2SC-372	1				
5	TR28-6	2SD-157	1				
6	H28-1	Transistor Cooler for 2SD-157	1				
7	S28-1	Screw, round head 3 x 8 mm	2				
		<b>Carbon Resistor with Stopper</b>					
8	R28-1,26,28,36	1/4 watt 10K	4				
9	R28-2,10,13	1/4 watt 180K	3				
10	R28-3,37	1/4 watt 8.2K	2				
11	R28-4	1/4 watt 330 Ω	1				
12	R28-5,18,25	1/4 watt 100K	3				
13	R28-6,7,32	1/4 watt 18K	3				
14	R28-8,30	1/4 watt 4.7K	2				
15	R28-9,23	1/4 watt 1.8K	2				
16	R28-11	1/4 watt 27K	1				
17	R28-12,20	1/4 watt 5.6K	2				
18	R28-14	1/4 watt 47K	1				
19	R28-15,27	1/4 watt 12K	2				
20	R28-16	1/4 watt 1K	1				
21	R28-17,22	1/4 watt 3.9K	2				
22	R28-19	1/4 watt 120K	1				
23	R28-21	1/4 watt 390 Ω	2				
24	R28-24	1/4 watt 560 Ω	1				
25	R28-29	1/4 watt 22K	1				
26	R28-33	1/4 watt 3K (J)	1				
27	R28-34	Metal Oxide Film Resistor 2W 1K	2				
28	R28-31	Solid Resistor 1/2 watt 2.7K	1				
29	R28-35	Solid Resistor 1/2 watt 270 Ω	1				
		<b>Electrolytic Capacitor, Vertical Mounting Type</b>					
30	C28-1,9,14	10 μ 10V	3				
31	C28-2,10,15	22 μ 6.3V	3				
32	C28-4	33 μ 25V	1				
33	C28-6	47 μ 6.3V	1				
34	C28-7,13,19,23	10 μ 25V	4				
35	C28-12,18	47 μ 25V	2				
36	C28-16	100 μ 50V	1				
37	C28-25	4.7 μ 50V	1				
		<b>Mylar Condenser, Vertical Mounting Type</b>					
38	C28-3,11	0.001 μ 50V	2				
39	C28-5,22	0.0022 μ 50V	2				
40	C28-17	47 μ 10V	1				
41	C28-20	0.47 μ 35V	1				
42	C28-24	0.12 μ 50V	1				
43	C28-26	0.068 μ 50V	1				
44	C28-27	0.22 μ 35V	1				
45	C28-28,29	0.012 μ 50V	2				
46	C28-30	0.022 μ 50V	1				
47	C28-8	Film Mica Condenser 150P 50V	1				
48	C28-21	Minature Film Mica Condenser 150P 50V	1				
49	VR28-1	20KB Semi-variable Resistor	1				

# MAIN AMPLIFIER PRINTED CIRCUIT BOARD (RD-531)

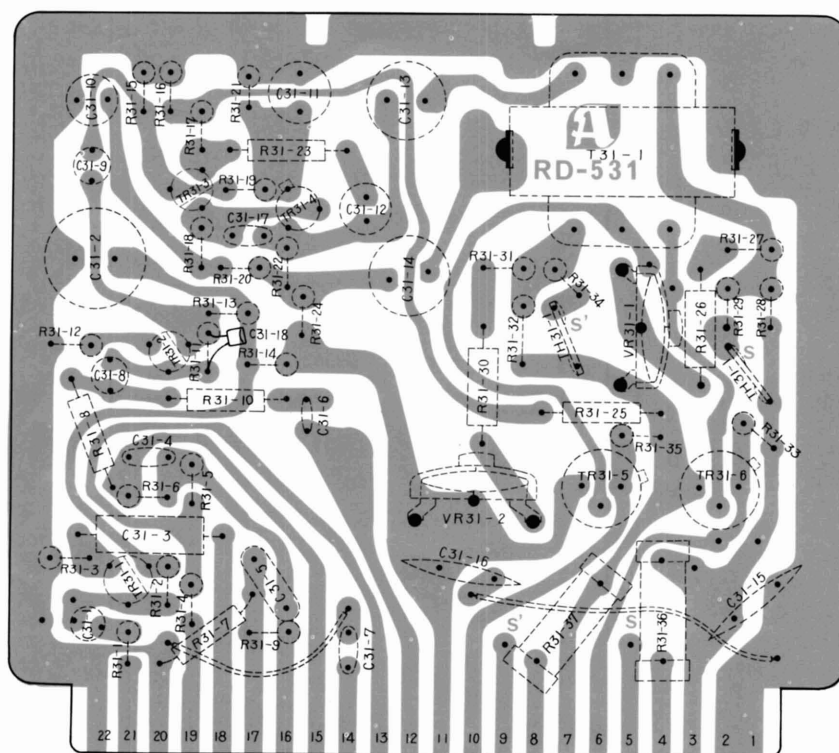
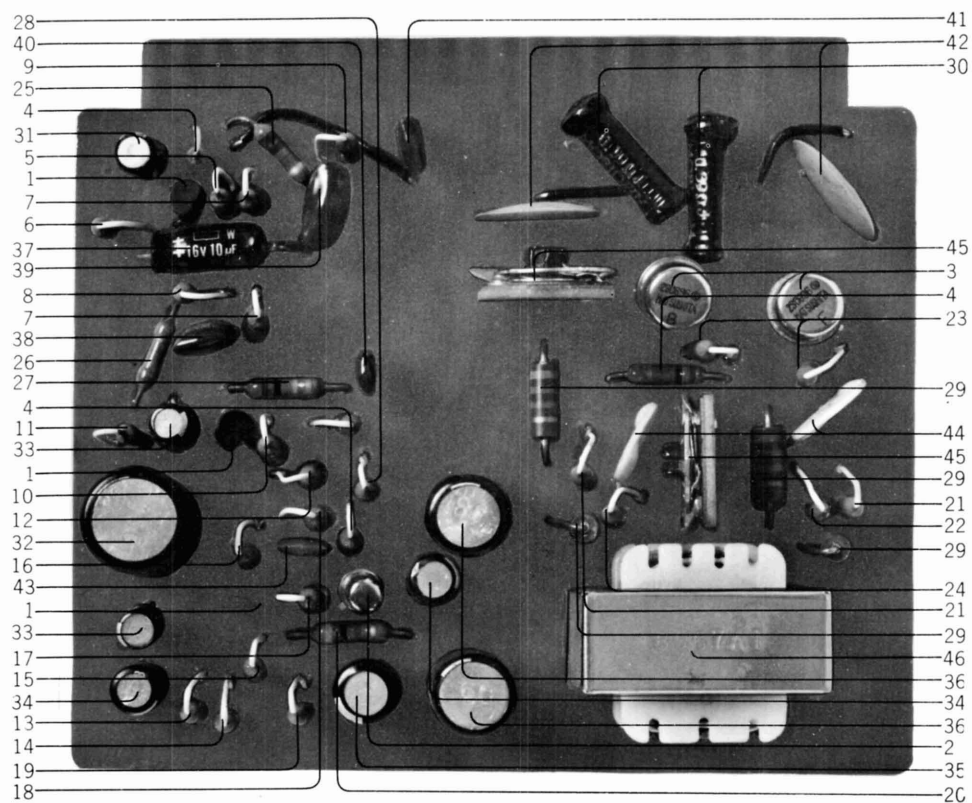

## MAIN AMPLIFIER PRINTED CIRCUIT BOARD (RD-531)

Ref. No.	Parts No.	Nomenclature	Quantity
	RD-531	Main Amplifier Printed Circuit Board Complete	1
		<b>Transistor</b>	
1	TR31-1,2,3	2SC828-R	3
2	TR31-4	2SC538-R.O.	1
3	TR31-5,6	2SC696-E.B.	2
		<b>Carbon Resistor with Stopper</b>	
4	R31-1,14, 22,25	1/4 watt 1 K	4
5	R31-2	1/4 watt 220K	1
6	R31-3	1/4 watt 2.2K	1
7	R31-4,5	1/4 watt 5.6K	2
8	R31-6	1/4 watt 130K	1
9	R31-9	1/4 watt 3.6K	1
10	R31-11	1/4 watt 470K	1
11	R31-12	1/4 watt 750 $\Omega$	1
12	R31-13	1/4 watt 5.6K	1
13	R31-15	1/4 watt 39K	1
14	R31-16	1/4 watt 56 $\Omega$	1
15	R31-17	1/4 watt 110 $\Omega$	1
16	R31-18	1/4 watt 33K	1
17	R31-19	1/4 watt 120K	1
18	R31-20	1/4 watt 12K	1
19	R31-21	1/4 watt 510 $\Omega$	1
20	R31-23	1/4 watt 3K	1
21	R31-28,32	1/4 watt 150 $\Omega$	2
22	R31-29	1/4 watt 100 $\Omega$	1
23	R31-33,35	1/4 watt 680 $\Omega$	2
24	R31-34	1/4 watt 100 $\Omega$	1
		<b>Carbon Resistor</b>	
25	R31-7	1/4 watt 1.1K	1
26	R31-8	1/4 watt 6.8K	1
27	R31-10	1/4 watt 10K	1
28	R31-24	1/4 watt 1K	1
		<b>Solid Resistor</b>	
29	R31-26,27, 30,31	1/2 watt 750 $\Omega$	4
		<b>Wire wound Resistor</b>	
30	R31-36,37	1 watt 0.39 $\Omega$	2
		<b>Electrolytic Capacitor, Vertical Mounting Type</b>	
31	C31-1	1 $\mu$ 16V	1
32	C31-2	220 $\mu$ 25V	1
33	C31-8,9	22 $\mu$ 25V	2
34	C31-10,12	10 $\Omega$ 25V	2
35	C31-11	100 $\mu$ 6.3V	1
36	C31-13,14	100 $\mu$ 25V	2
		<b>Electrolytic Capacitor, Tublar Type</b>	
37	C31-3	10 $\mu$ 16V	1
		<b>Mylar Condenser</b>	
38	C31-4	0.022 $\mu$ 50V	1
39	C31-5	0.22 $\mu$ 35V	1
40	C31-6	0.0022 $\mu$ 50V	1
41	C31-7	0.027 $\mu$ 50V	1
42	C31-15,16	Styrol Condenser 0.1 $\mu$ 50V	2
43	C31-17,18	Film Condenser 100P 50V	2
44	TH31-1	Thermister D41A	2
45	VR31-1,2	200 $\Omega$ B Semi-variable Resistor	2
46	T31-1	In-put Transformer N28-6067AT	1

MONITOR SWITCH PRINTED CIRCUIT BOARD (RD-523)

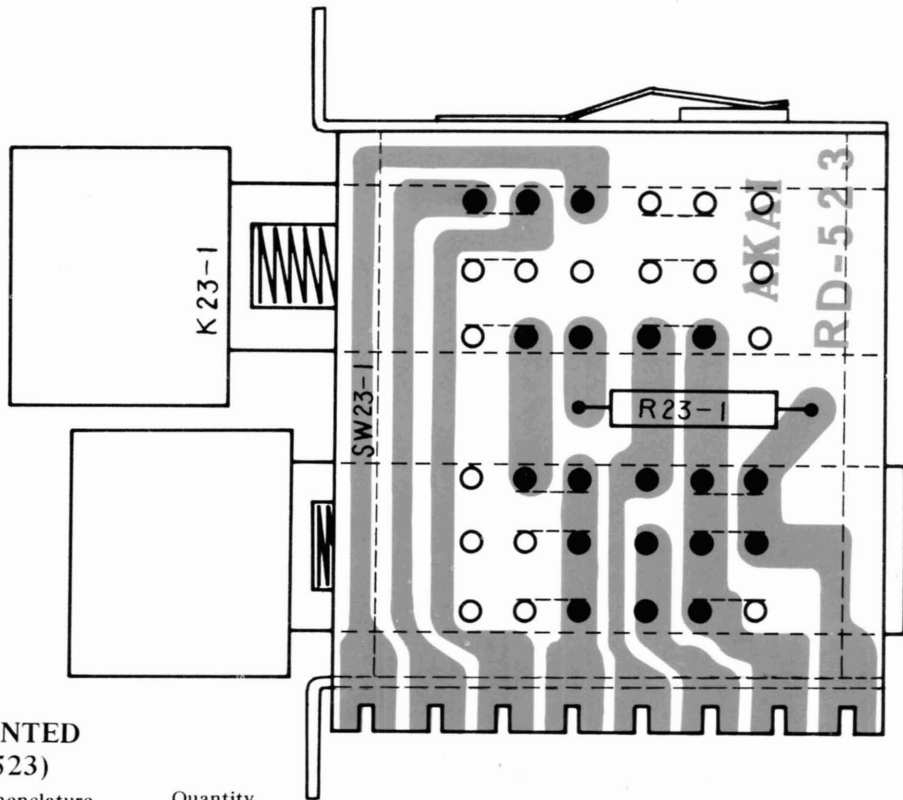
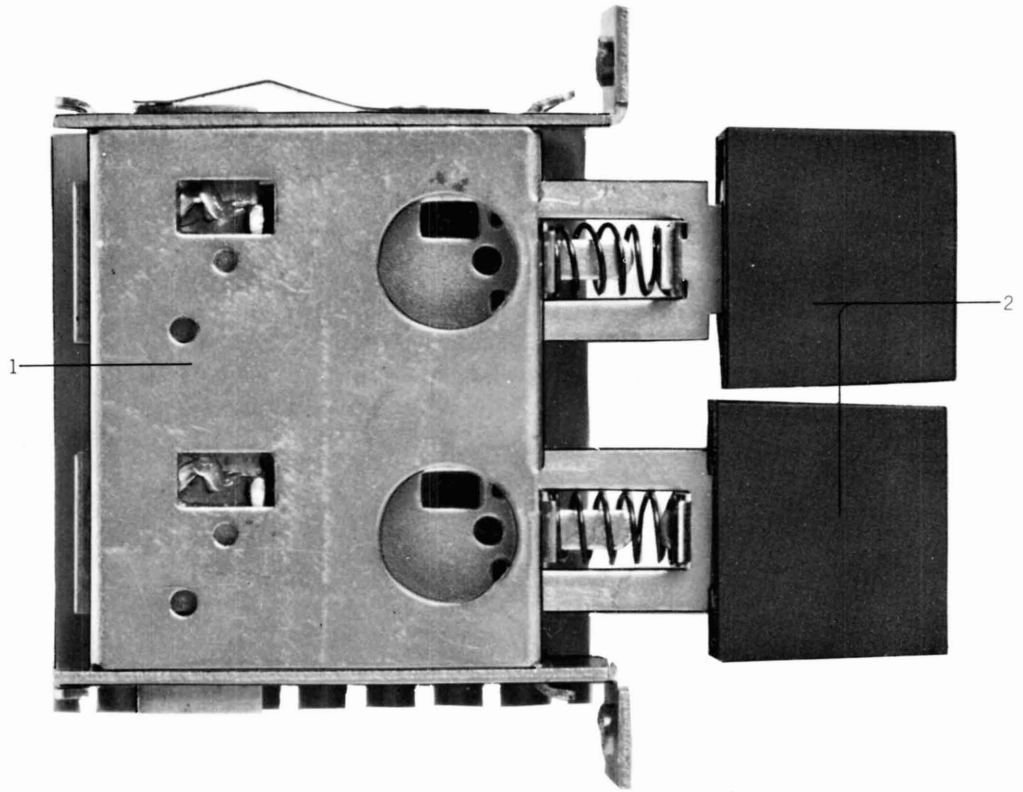

MONITOR SWITCH PRINTED CIRCUIT BOARD (RD-523)

Ref. No.	Parts No.	Nomenclature	Quantity
	RD-523	Monitor Switch Printed Circuit Board Assembly Complete	1
1	SW23-1	Monitor Push Switch UM21220J	1
2	K23-1	Knob, Monitor Switch	2
3	R23-1	Carbon Resistor 1/4 watt 68K	1



## TRACK SELECTOR PRINTED CIRCUIT BOARD (RD-522)

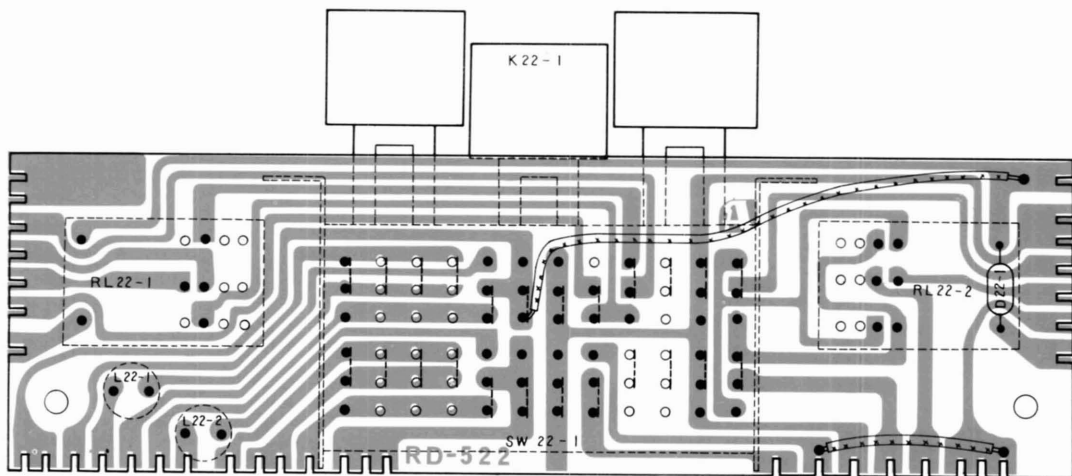
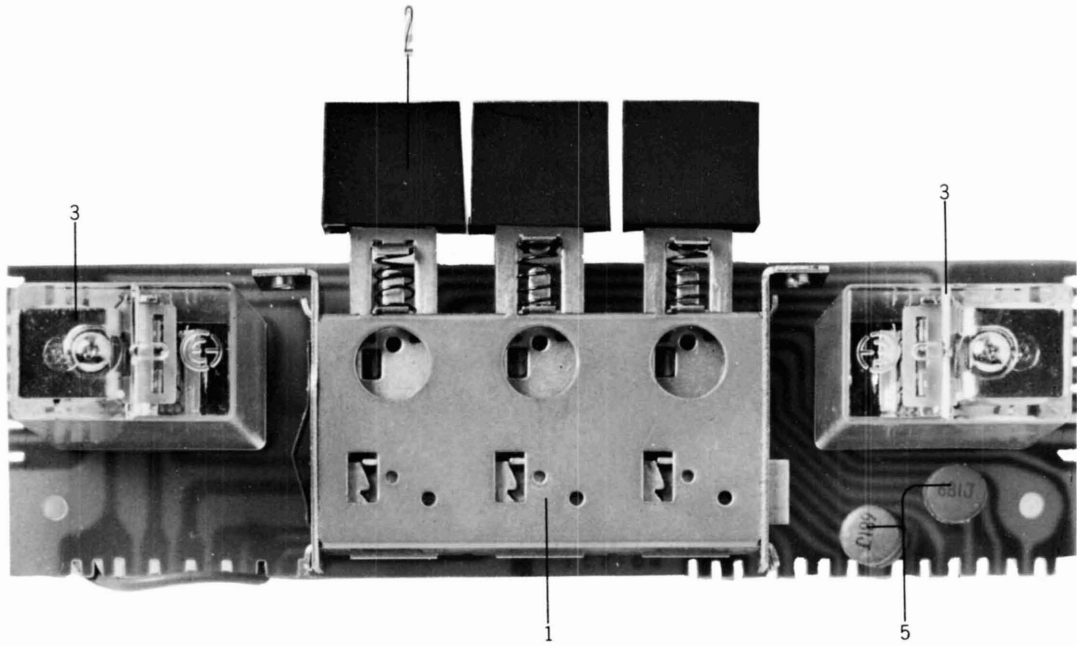

## TRACK SELECTOR PRINTED CIRCUIT BOARD (RD-522)

Ref. No.	Parts No.	Nomenclature	Quantity	Ref. No.	Parts No.	Nomenclature	Quantity
	RD-522	Track Selector Printed Circuit Board Assembly Complete	1	3	RL22-1,2	Relay, MQ-1395	2
1	SW22-1	Track Selector Switch UM32420C	1	4	D22-1	Silicon Diode SL-150	1
2	K22-1	Knob, Track Selector Switch	3	5	L22-1,2	Inductive Coil FL-9H 680mH	2

COM PRINTED CIRCUIT BOARD BLOCK (RD-570)

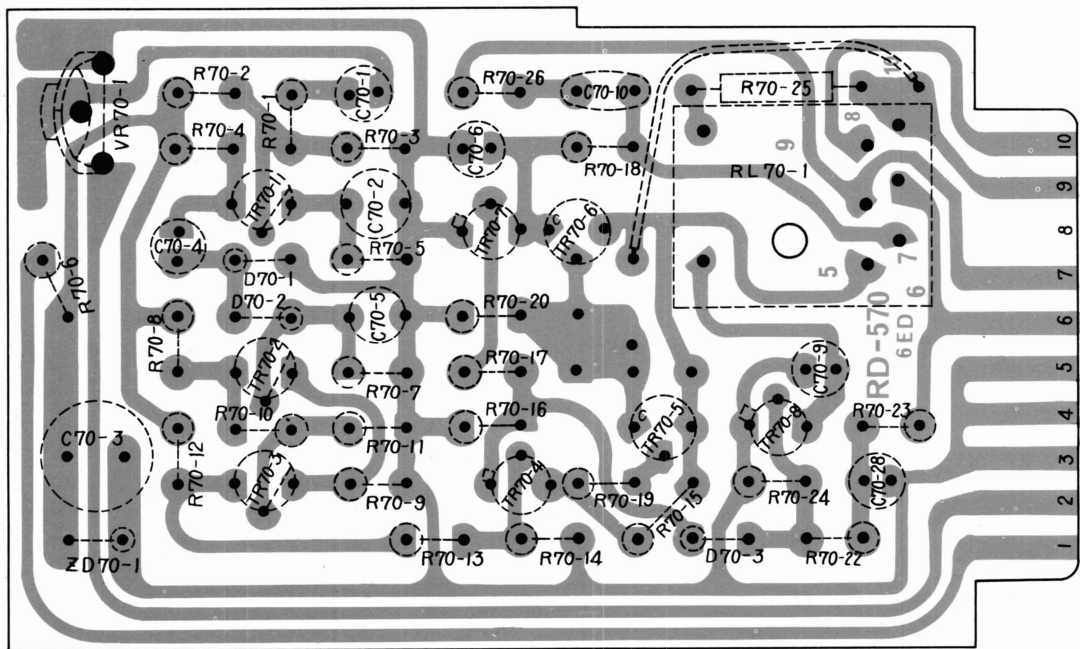
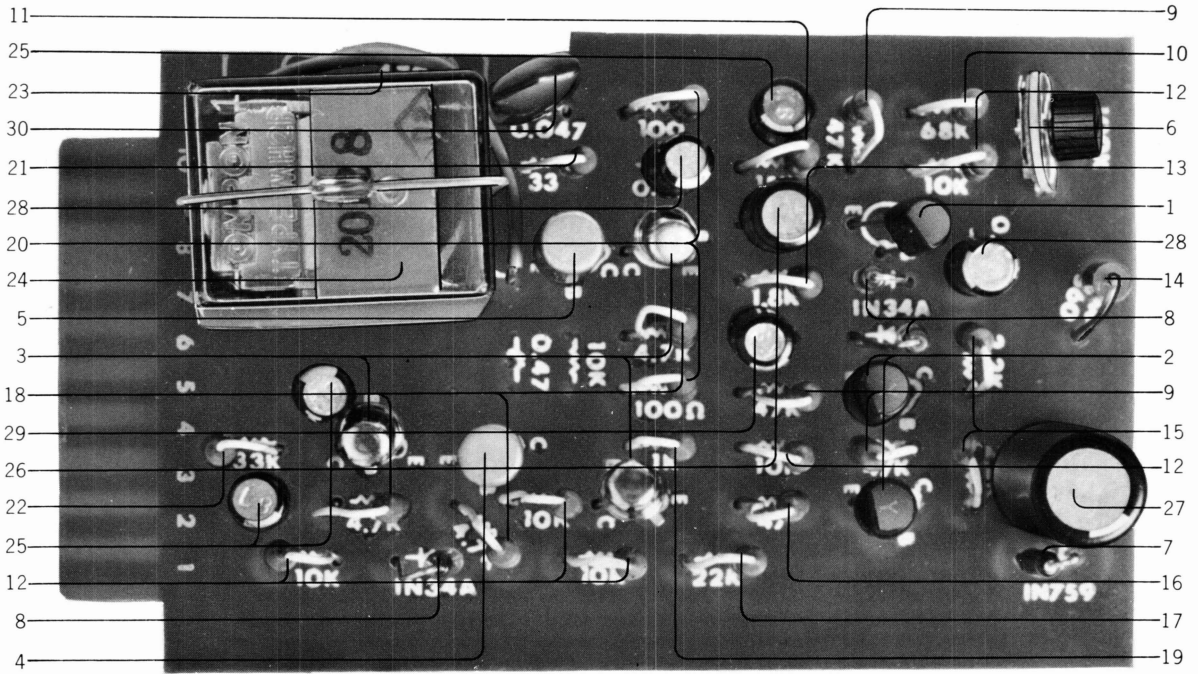

## COM PRINTED CIRCUIT BOARD BLOCK (RD-570)

Ref. No.	Parts No.	Nomenclature	Quantity
	RD-570	COM Printed Circuit Board Complete	1
		<b>Transistor</b>	
1	TR70-1	2SC828 (T)	1
2	TR70-2,3	2SC372	2
3	TR70-4,7,8	2SC538A (Q)	3
4	TR70-5	2SB75A (B)	1
5	TR70-6	2SB77A (B)	1
6	VR70-1	100K (B) Semi-variable Resistor	1
7	ZD70-1	Zener Diode IN 759A	1
8	D70-1,2,3	Germanium Diode IN34A	3
		<b>Carbon Resistor with Stopper</b>	
9	R70-1,7,10	1/4 watt 47K	3
10	R70-2	1/4 watt 68K	1
11	R70-3	1/4 watt 15K	1
12	R70-4,11, 14,19,22	1/4 watt 10K	5
13	R70-5	1/4 watt 1.8K	1
14	R70-6	1/4 watt 560 $\Omega$	1
15	R70-8,12	1/4 watt 2.2K	2
16	R70-9	1/4 watt 47 $\Omega$	1
17	R70-13	1/4 watt 22K	1
18	R70-15, 20,24	1/4 watt 4.7K	3
19	R70-16	1/4 watt 1K	1
20	R70-17,26	1/4 watt 100 $\Omega$	2
21	R70-18	1/4 watt 33 $\Omega$	1
22	R70-23	1/4 watt 33K	1
23	R70-25	1/4 watt 470 $\Omega$	1
24	RL70-1	Relay MH2PM-0 with socket	1
		<b>Electrolytic Capacitor, vertical mounting type</b>	
25	C70-1,8,9	1 $\mu$ 50V	3
26	C70-2	33 $\mu$ 3.15V	1
27	C70-3	100 $\mu$ 25V	1
28	C70-4,6	0.47 $\mu$ 50V	2
29	C70-5	4.7 $\mu$ 16V	1
		<b>Mylar Condenser, vertical mounting type</b>	
30	C70-10	0.047 $\mu$ 50V	1

C.O.M. SET SWITCH PRINTED CIRCUIT BOARD (RD-525)

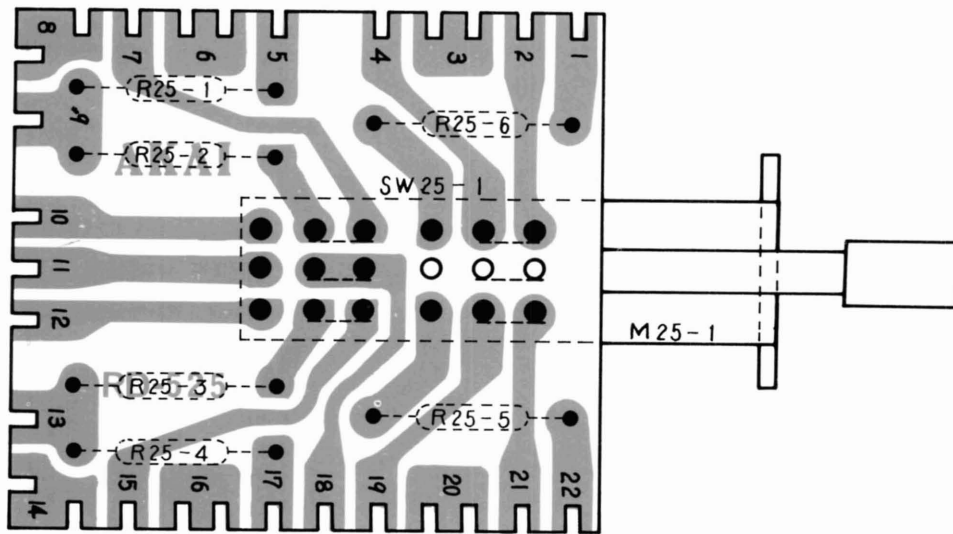
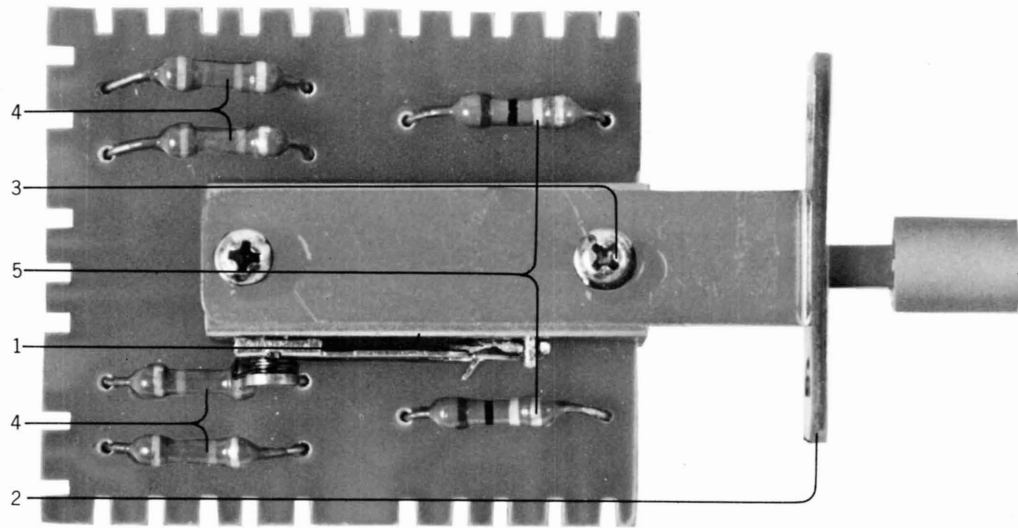

C.O.M. SET SWITCH PRINTED CIRCUIT BOARD (RD-525)

Ref. No.	Parts No.	Nomenclature	Quantity	Ref. No.	Parts No.	Nomenclature	Quantity
	RD-525	C.O.M. Set Switch Printed Circuit Assembly Complete	1	3	S25-1	Screw, round head 2.6 x 4 mm	2
1	SW25-1	C.O.M. Set Switch UEG-62	1	4	R25-1,2,3,4	Carbon Resistor 1/4 watt 47K	4
2	M25-1	Bracket, C.O.M' Set Switch Printed Circuit Board Mounting	1	5	R25-5,6	Carbon Resistor 1/4 watt 100K	2

C.O.M. MECHANIC BLOCK (RD-2200)

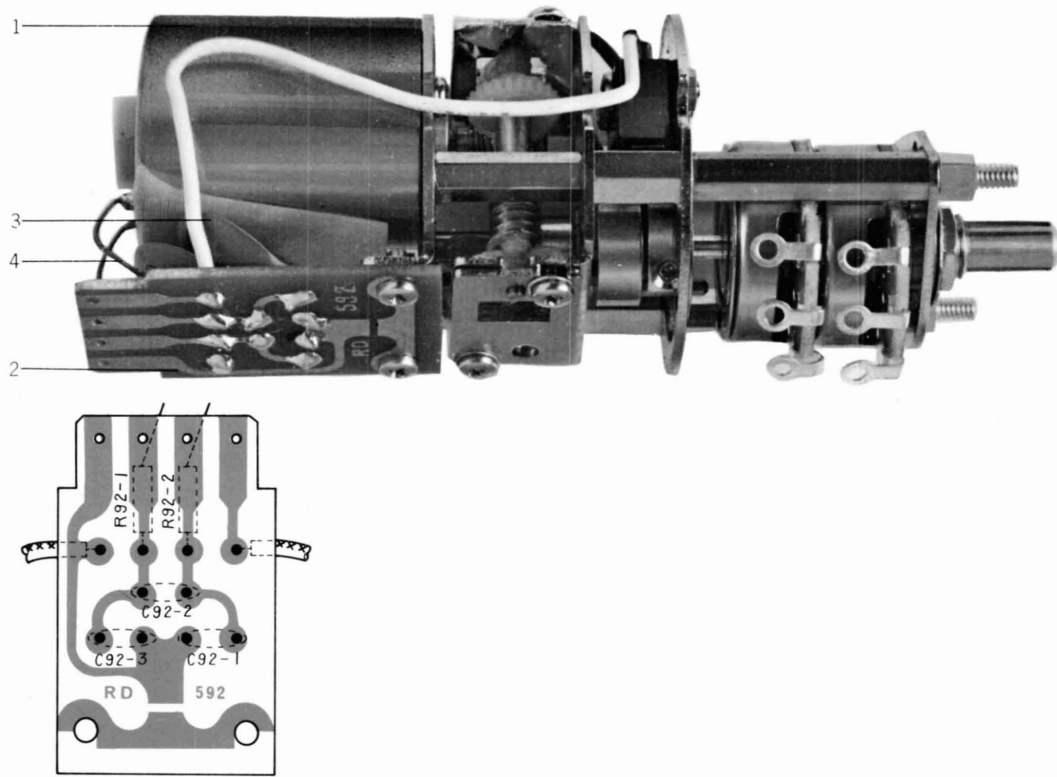

C.O.M. MECHANIC BLOCK (RD-2200)

Ref. No.	Parts No.	Nomenclature	Quantity	Ref. No.	Parts No.	Nomenclature	Quantity
	RD-2200	C.O.M. Volume Assy. with Micro Motor (FM-36K) contained in Rubber Cover	1	3	C92-1,2,3	Ceramic Condenser 0.1 $\mu$ 50V	3
1	RD-2201	Micro Motor (FM-36K)	1	4	R92-1,2	Solid Resistor 1/4 watt 33 $\Omega$ (K)	2
2	RD-2202	C.O.M. Terminal Circuit Board Comp. (RD-592) without Resistor	1				

## SPARK QUENCHER & MICRO SWITCH BLOCK (RD-150B)

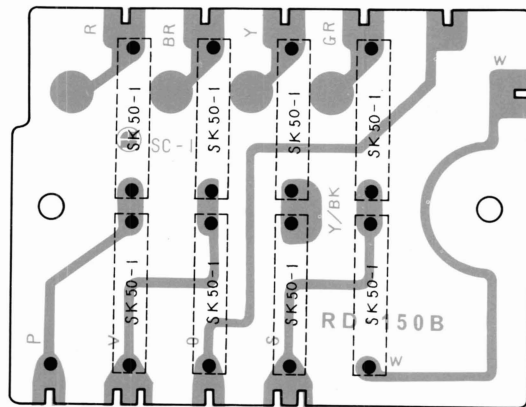
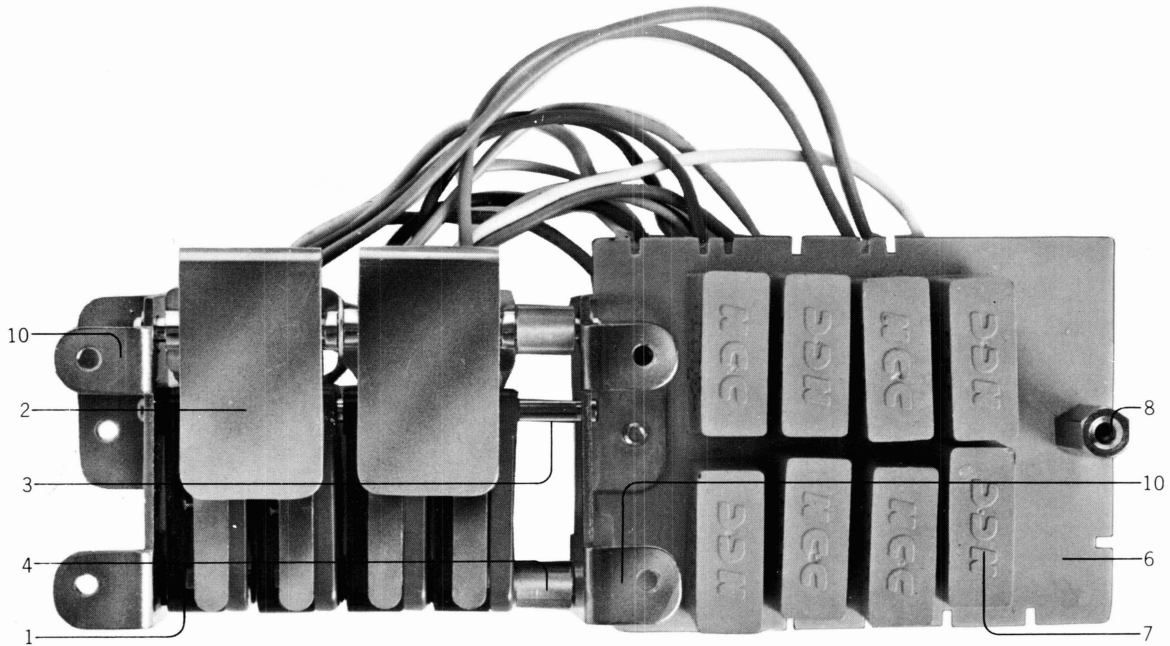

## SPARK QUENCHER & MICRO SWITCH BLOCK (RD-150B)

Ref. No.	Parts No.	Nomenclature	Quantity	Ref. No.	Parts No.	Nomenclature	Quantity
	RD-150B	Spark Quencher and Micro Switch Assembly Complete	1	6	RD-2016	Spurk Quencher Block (RD-150)	1
1	RD-2011	Micro Switch V-1A44	4	7	SK50-1	Spark Quencher Compound	8
2	RD-2012	Actuator for Micro Switch	2	8	P50-1	Prop (hex.) for Printed Circuit Board	1
3	RD-2013	Shaft 3 x 55 mm (Micro Switch Mounting)	3	9	S50-1	Screw, binding head 3 x 5 mm	2
4	RD-2014	Metal Sleeve, Micro Switch Mounting 6 x 7 mm	2	10	RD-2017	Bracket, Micro Switch Mounting	3
5	RD-2015	"E" Ring 1.9 mm	6				

**SPEED SELECTOR SWITCH BLOCK (RD-139B)**

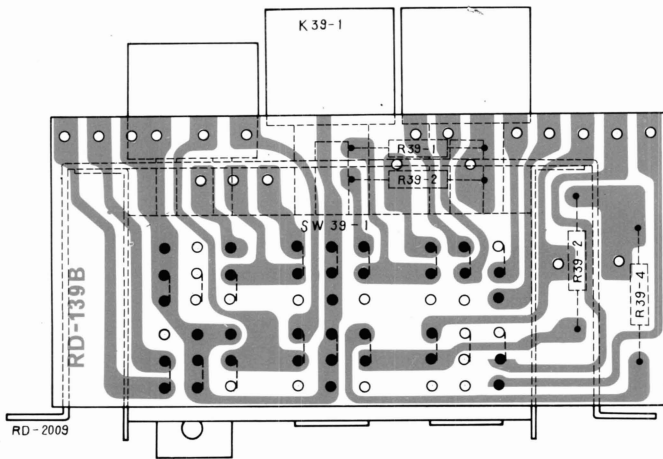
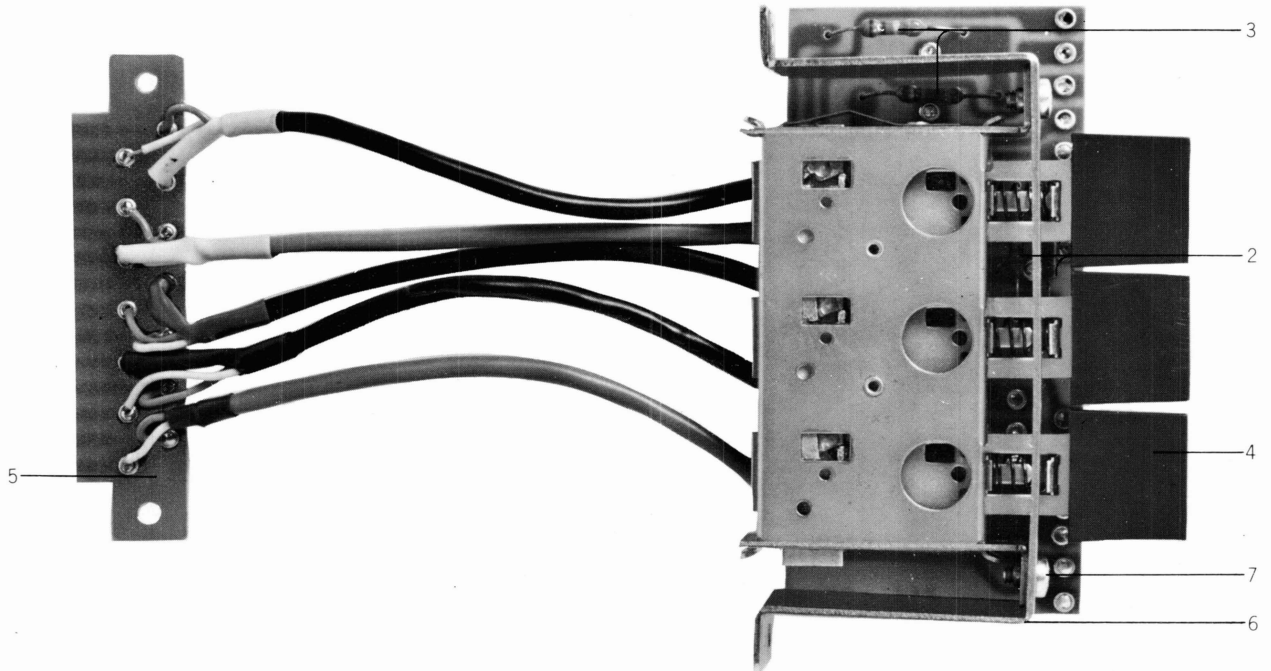

**SPEED SELECTOR SWITCH BLOCK (RD-139B)**

Ref. No.	Parts No.	Nomenclature	Quantity	Ref. No.	Parts No.	Nomenclature	Quantity
1	RD-2008	Speed Selector Switch Assembly Complete (RD-139B)	1	4	K39-1	Knob, Speed Selector Switch	3
2	RD39-1,2	Carbon Resistor 1/4 W 36K (J)	2	5	P39-1	Printed Plug 14P	1
3	RD39-3,4	Carbon Resistor 1/4 w 11K (J)	2	6	RD-2009	Bracket, Speed Selector Switch Mounting	1
				7	RD-2010	Screw, pan head 3 x 5 mm	2

AMPLIFIER CHASSIS BLOCK (RD-2300)

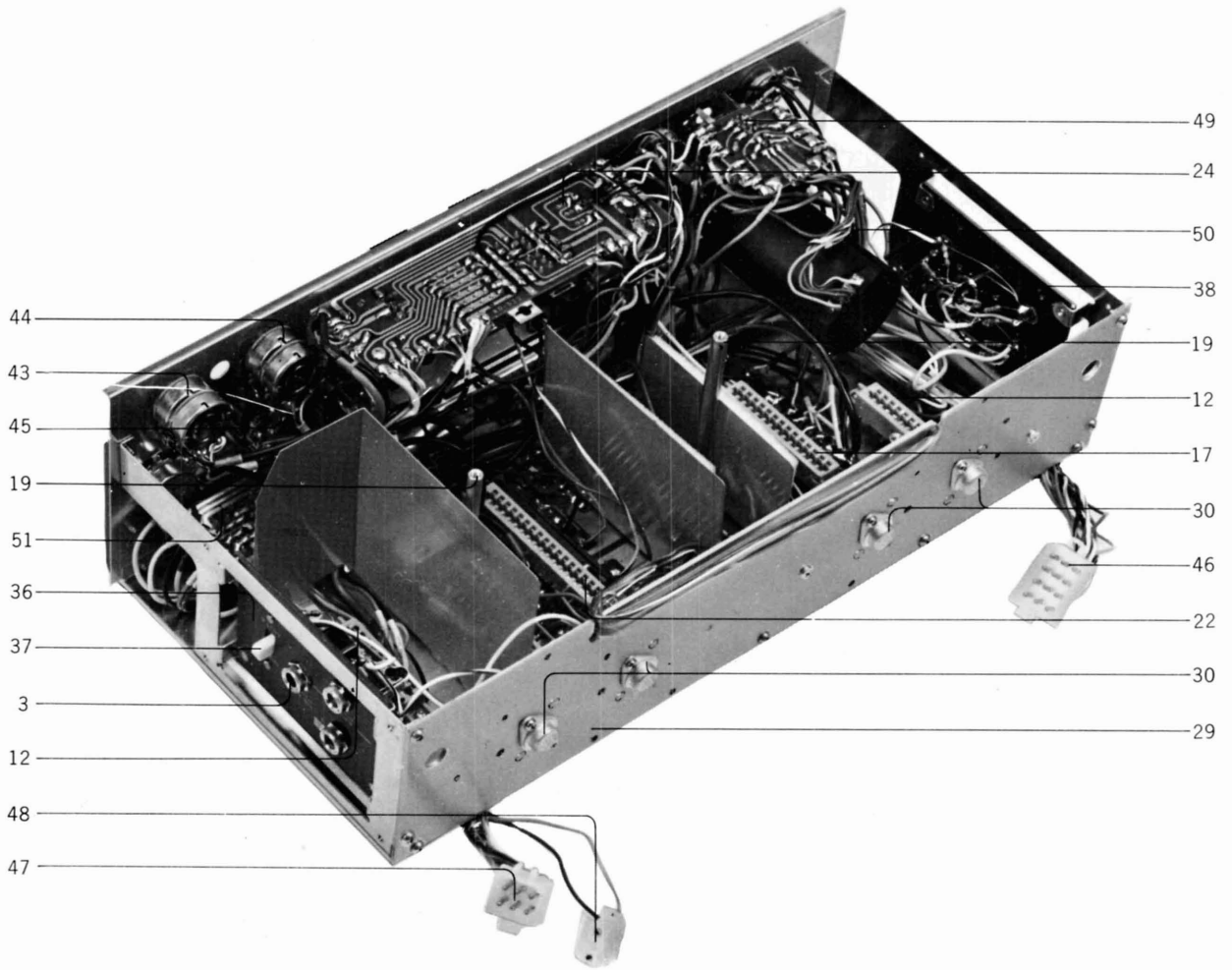
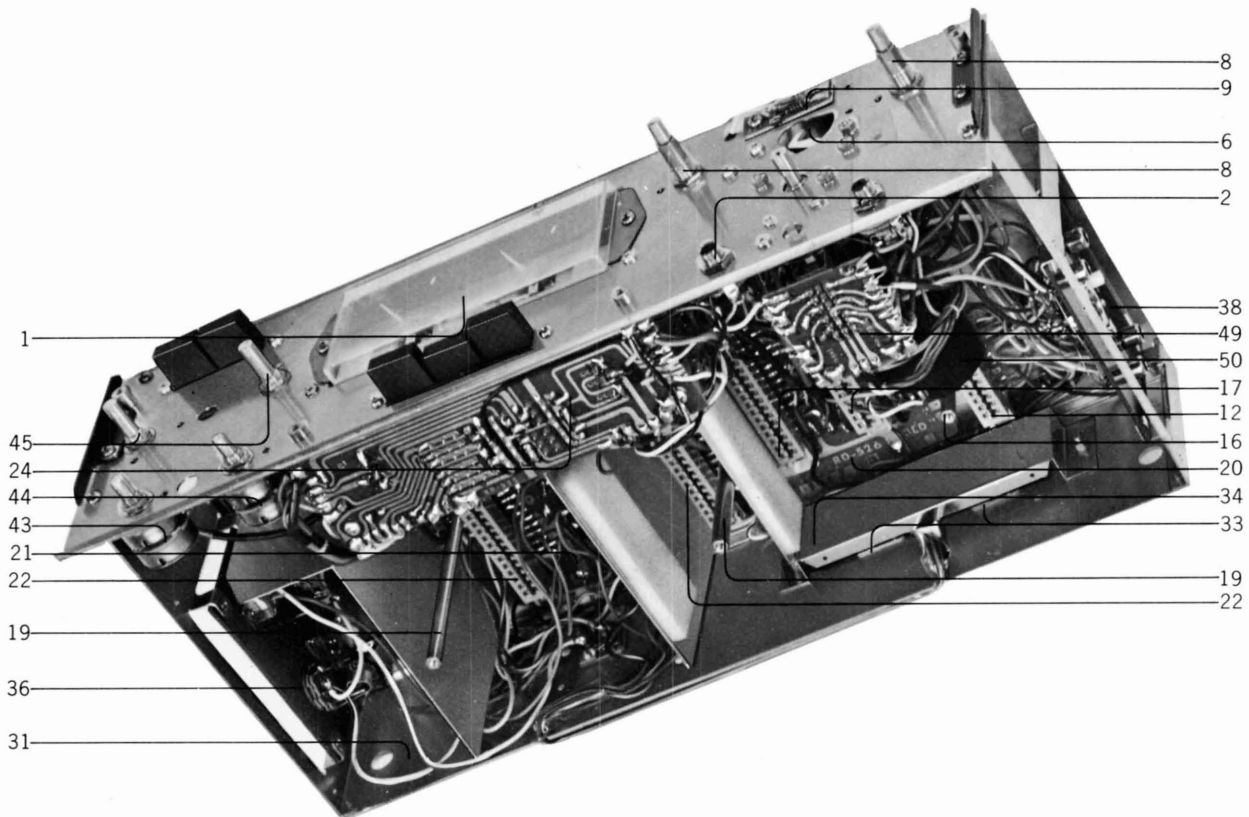



## AMPLIFIER CHASSIS BLOCK (RD-2300)

Ref. No.	Parts No.	Nomenclature	Quantity	Ref. No.	Parts No.	Nomenclature	Quantity
1	RD-2301	VU Meter (twin Type)	1	36	RD-2335	Speaker Jack Plate	
2	RD-2302	Mic. Jack (2-conductor "E" Type)	2			Assembly Complete	1
3	RD-2303	Headphone Jack (3-conductor "E" type)	1	37	RD-2336	Speaker Switch	1
4	RD-2304	Bracket, Recording Switch Mounting	1	38	RD-2337	Line Jack Plate Assembly Complete	1
5	RD-2305	Screw, binding head 3 x 5 mm (with washer)	2	39	RD-R3,4	Carbon Resistor 1/4 W 33K (K)	2
6	RD-2306	Micro Switch (VV-15-3A) for Recording	1	40	RD-R5,6	Carbon Resistor 1/4 W 150K (K)	2
7	RD-2307	Screw, round head 3 x 15 mm (for micro switch)	2	41	RD-R7,8	Carbon Resistor 1/4 W 22K (K)	2
8	RD-2308	Mic. Volume Control with Tone (D24N 50KA/100KA)	2	42	RD-R9,10	Carbon Resistor 1/4 W 10K (K)	2
9	RD-2309	Indicator Lamp Printed Board	1	43	RD-2338	Volume, Bass Control 50KAx2 (VR-4a)	1
10	RD-2310	Lamp (NE-2Q)	1	44	RD-2339	Volume, Treble Control 50KA x 2	1
11	RD-2311	Solid Resistor 1/4 watt 33K	1	45	RD-2340	Volume Control, left and right (VR-3)	2
12	RD-2312	10P Printed Circuit Connector	2	46	RD-2341	12P Plug,	1
13	RD-2313	Screw, round head 3 x 6 mm	10	47	RD-2342	6P Plug	1
14	RD-2314	Prop A, Connector Mounting	8	48	RD-2343	3P Plug	1
15	RD-2315	Screw, binding head 3 x 5 mm	13	49	RD-525	C.O.M. Set Switch, Printed Circuit Assy. Comp.	1
16	RD-2316	Prop B, Printed Circuit Retaining	1	50	RD-2200	C.O.M. Volume Assy. with Micro Motor	1
17	RD-2317	14P Printed Circuit Connector	2	51	RD-523	Monitor Switch, Printed Circuit Board Assy. Comp.	1
18	RD-2318	Screw, round head 3 x 12 mm	4				
19	RD-2319	Prop, Printed Circuit Retaining	2				
20	RD-2320	Printed Circuit Board (RD-526)	1				
21	RD-2321	Printed Circuit Board (RD-532)	1				
22	RD-2322	22P Printed Circuit Connector	3				
23	RD-2323	Prop C, Connector Mounting	6				
24	RD-522	Track Selector Board	1				
25	RD-2324	Bucking, for Retaining Track Selector Switch	2				
26	RD-2325	Screw, binding head 3 x 8 mm	2				
27	RD-2326	Bracket, Printed Board Mounting	2				
28	RD-2327	Screw, binding head 3 x 5 mm	4				
29	RD-2328	Heat Sink Block	1				
30	RD-2329	Transistor 2SD-130R	4				
31	RD-2330	Plate, Heat Sink	1				
32	RD-2331	Set Screw 3 x 8 mm	8				
33	RD-2332	Socket, Transistor Mounting	4				
34	RD-2333	Transistor Cover	1				
35	RD-2334	Screw, binding head 3 x 8 mm	2				

CASE & TOP PANEL (RD-2500)

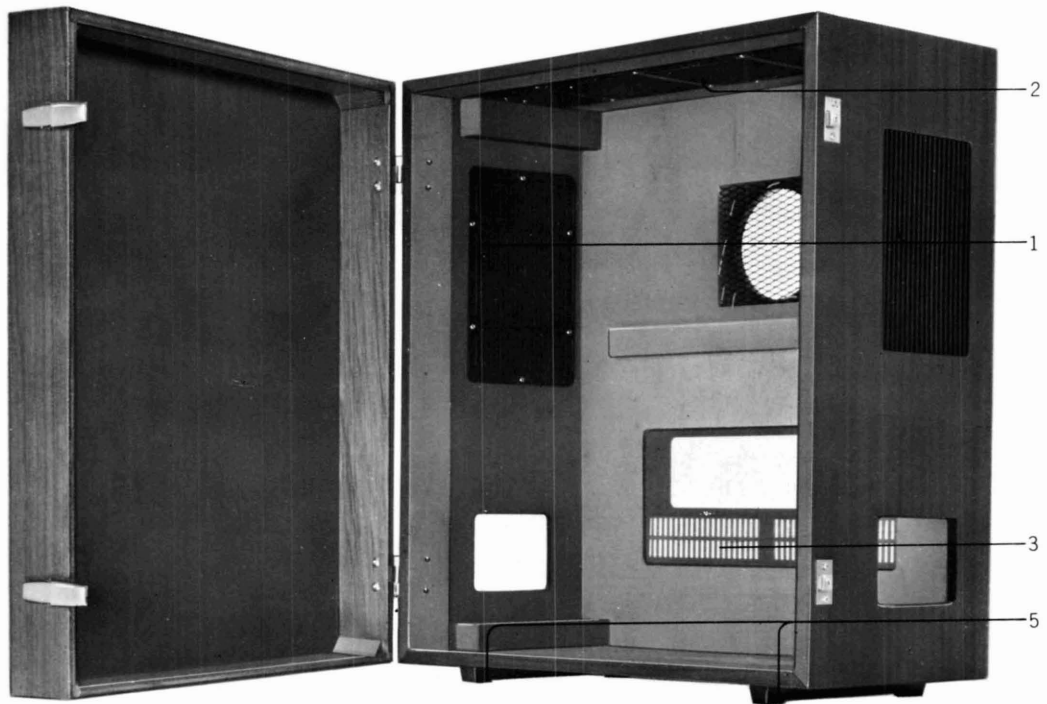

## CASE & TOP PANEL (RD-2500)

Ref. No.	Parts No.	Nomenclature	Quantity	Ref. No.	Parts No.	Nomenclature	Quantity
	RD-2500	Case Complete	1	50	K23-1	Knob, Monitor, Switch	2
1	RD-2501	Escutcheon, Speaker	2	51	K22-1	Knob, Track Selector	
2	RD-2502	RD Escutcheon	1			Switch	3
3	RD-2503	Ventilator	1	52	RD-2018	Knob, Function Switch	5
4	RD-2504	Screw, truss head 3 x 6 mm	4				
5	RD-2505	Oblong Foot	2				
6	RD-2506	Screw, flat head 4 x 15 mm	4				
7	RD-2507	Rubber Foot	2				
8	RD-2508	Tapping Screw 4 x 25 mm	4				
9	RD-2509	Panel, Deck Cover	1				
10	RD-2510	Screw, truss head 3 x 6 mm	4				
11	RD-2511	Main Head Cover A	1				
12	RD-2512	Head Cover B	1				
13	RD-2513	Set Screw (Head Cover B)	1				
14	RD-2514	Knob, Brake Control	1				
15	RD-2515	Screw, with head 3 x 4 mm	1				
16	RD-2516	Knob, Shut off Switch	1				
17	RD-2517	Screw, without head 3 x 5 mm	1				
18	RD-1212	Pinch Wheel 7.5 inch	1				
19	RD-1213	Pinch Wheel Cap	1				
20	RD-2520	Pinch Wheel 15 inch	1				
21	RD-2521	Capstan for 15 inch	1				
22	RD-2522	Bracket, Tape Cleaner	1				
23	RD-2523	Set Screw (Minus head)	1				
24	RD-2524	Panel, Amplifier Cover with Meter Escutcheon	1				
25	RD-2525	Screw, truss head 3 x 8 mm (BNI)	4				
26	RD-2526	Meter Escutcheon	1				
27	RD-2527	Screw, oval counter sunk head 2.3 x 4 mm	1				
28	RD-2528	Recording Safety Escutcheon	1				
29	RD-2529	Knob, Line Record Level Control	2				
30	RD-2530	Set Screw, 4 x 7 mm	2				
31	RD-2531	Knob, microphone Record Level Control	2				
32	RD-2532	Set Screw 4 x 6.5 mm	2				
33	RD-2533	Knob, Volume Control	2				
34	RD-2534	Set Screw 4 x 6.5 mm	2				
35	RD-2535	Knob, Recording Safety	1				
36	RD-2536	Clip, Retaining	1				
37	RD-2537	Lever, Recording Safety Locking	1				
38	RD-2538	Guide Screw	1				
39	RD-2539	Tension Spring	1				
40	RD-2540	Knob, Bass Control	1				
41	RD-2541	Set Screw 3 x 4 mm	2				
42	RD-2542	Knob, Treble Control	1				
43	RD-1615	Reverse Set Dial	1				
44	RD-1618	Tape Count Meter Dial	1				
45	RD-1408	Supply Reel Table Complete	1				
46	RD-1419	Take-up Reel Table Complete	1				
47	RD-1747	Tape Counter Complete	1				
48	RD-1301	Stabilizer Shaft	1				
49	K39-1	Knob, Speed Selector Switch	3				

HEADPHONE PRINTED CIRCUIT BOARD (RD-524)

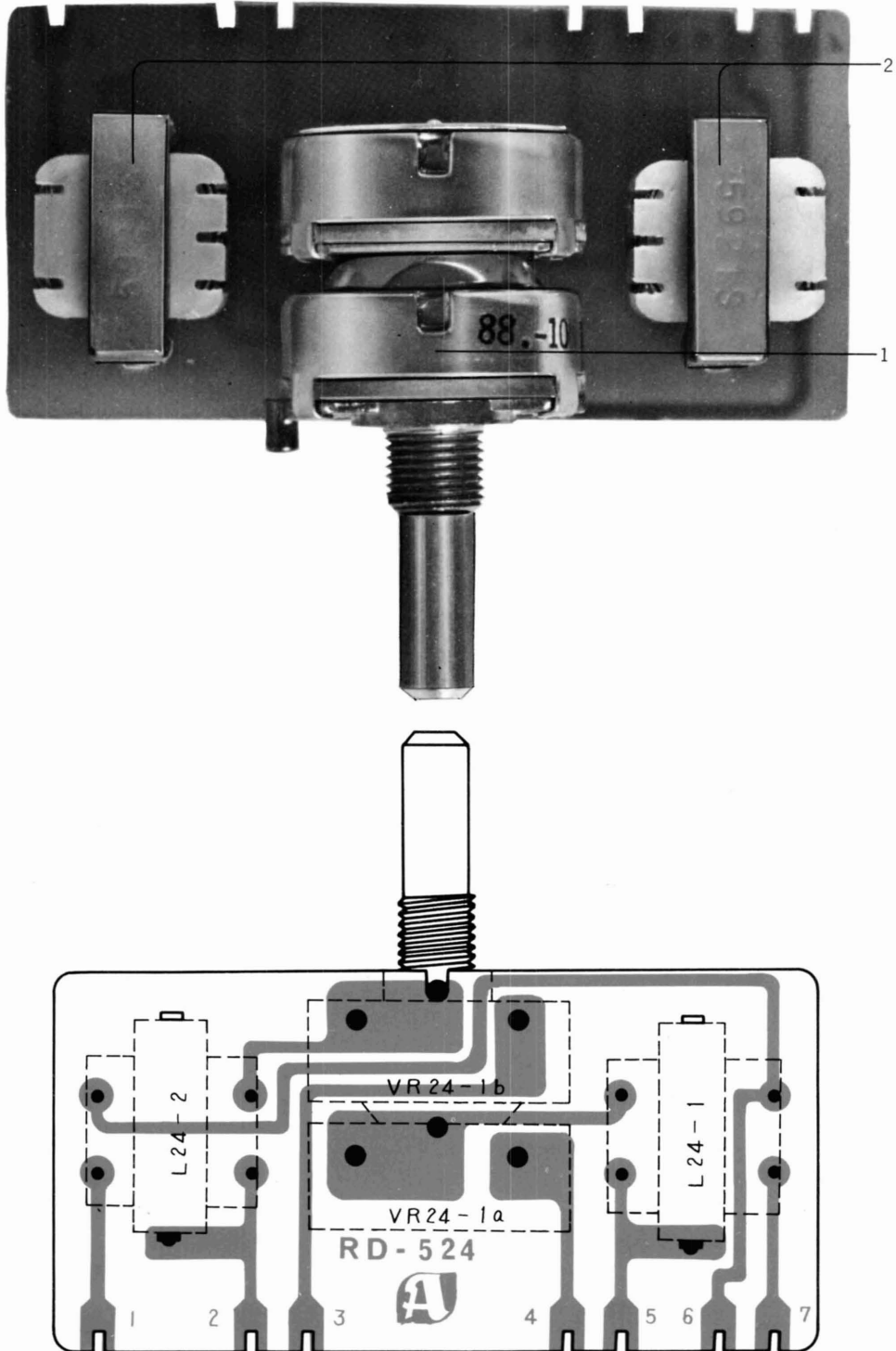

HEADPHONE PRINTED CIRCUIT BOARD (RD-524)

Ref. No.	Parts No.	Nomenclature	Quantity
	RD-524	Headphone Printed Circuit Board Assembly Complete	1
1	VR24-1	Headphone Volume Control 10KAx2	1
2	L24-1,2	Transformer, N19-5921S	2

### CHASSIES PRINTED BOARD (RD-526)

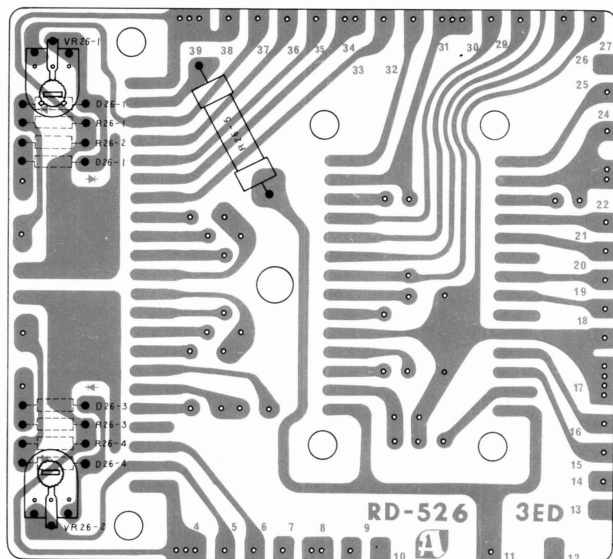

### MAIN AMPLIFIER SOCKET BOARD (RD-532)

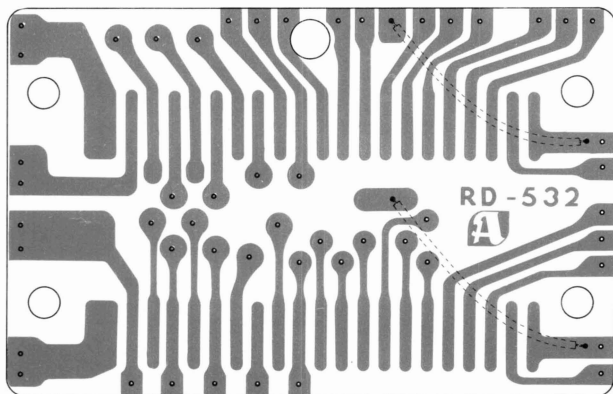

Ref. No.	Parts No.	Nomenclature	Quantity
	RD-526	Chassis Printed Board Assy. Comp.	1
1	D26-1~4	Germanium Diode IN34A	4
2	R26-1~4	Solid Resistor 1/4 watt 1K (K)	4
3	R26-5	Solid Resistor 2 Watt 820Ω (K)	1
4	VR26-1,2	2KB Semi-variable Resistor	2
5	RD-532	Main Amplifier Socket Board	1

### X-360D is not provided the parts listed below:

Parts No.	Nomenclature
RD-531	Main Amplifier Printed Circuit Board Complete
RD-2328	Heat Sink Block
RD-2123	3P Socket
RD-2343	3P Plug
RD-2335	Speaker Jack Plate Assembly Complete
RD-2338	Volume, Bass Control 50K $\times$ 2 (VR-4a)
RD-2540	Knob, Bass Control
RD-2541	Set Screw 3 x 4 mm
RD-2339	Volume, Treble Control 50KA x 2
RD-2542	Knob, Treble Control
RD-2541	Set Screw 3 x 4 mm
RD-2340	Volume Control, left and right (VR-3)
RD-2533	Knob, Volume Control
RD-2534	Set Screw 4 x 6.5 mm

#### Power Source Block

RD-2104	Power Transformer (RD-T3)
RD-2121	Plate, Diode Mounting
RD-2122	Screw, binding head 3 x 5 mm
RD-2123	Silicon Diode 5B2
RD-2124	Screw, binding head 3 x 8 mm
RD-2108	Electrolytic Capacitor 1000 $\mu$ 35V
RD-2109	Electrolytic Capacitor 1000 $\mu$ 63V
RD-2110	Screw, round head 3 x 3 mm
RD-2112	Wire Wound Resistor 4W 4 $\Omega$ (J)
RD-2121	6P Socket
RD-2342	6P Plug

\*Case Complete have to be changed.

RD-2501	Escutcheon, Speaker
RD-2124	Speaker
RD-2126	Screw, binding head 3 x 12 mm
RD-2127	Lug Plate (KPL-1)
RD-2128	Wire Wound Resistor 3 W 16 $\Omega$

### X-360 is not provided next parts listed below:

RD-524	Headphone Printed Circuit Board Assy. Comp.
VR24-1	Headphone Volume Control 10K $\times$ 2
L24-1,2	Transformer N19-5921S

## XII. SCHEMATIC DIAGRAM NUMBER CLASSIFICATION

Schematic Diagram Number Classification according to Serial Numbers.

### X-360

Serial Number	REC. RD528	P.B. RD529	OSC. RD530	DM RD271	COM RD570	PWR/AMP RD531	SYSCON RD144	AMP CHASSIS
710-0001 – 710-0500	R-1	P-1	O-1	D-1	C-1	W-1	S-1	A-1
808-0001 – 808-0700	↓	↓	↓	↓	↓	↓	↓	↓
808-0701 – 808-1000	↓	↓	↓	D-2	↓	↓	↓	↓
808-1001 – 808-2000	R-2	↓	↓	↓	↓	↓	S-2	A-2
1204-0001 – 1204-1000	↓	↓	↓	↓	↓	↓	S-3	↓
103-0001 – 103-0800	R-3	P-2	O-2	↓	↓	↓	S-4	↓

### X-360D

Serial Number	REC. RD528	P.B. RD529	OSC. RD530	DM RD271	COM RRD570	SYSCON RD144	AMP CHASSIS	
704-0001 – 704-0500	R-1	P-1	O-1	D-1	C-1	S-1	A-1	
807-0001 – 807-1500	↓	↓	↓	↓	↓	↓	↓	
904-0001 – 904-0440	↓	↓	↓	D-2	↓	↓	↓	
1006-0001 – 1006-0200	↓	↓	↓	↓	↓	↓	↓	
1102-0001 – 1102-0500	↓	↓	↓	↓	↓	↓	↓	
1203-0001 – 1203-1000	R-2	↓	↓	↓	↓	S-3	A-2	
102-0001 – 102-1200	R-3	P-2	O-2	↓	↓	S-4	↓	

#### \* NOTE

#### INTERCHANGEABILITY

1. There are three types of Recording Amplifier Boards (RD-528). They are no interchangeable.
2. The SYSCON board (RD-144) is interchangeable only when the new board is installed on an old tape recorder.
3. All other boards are interchangeable.
4. Amp. Chassis is no interchangeable.

# REFERENCE FOR THE REPAIR I RD-144 System Control Board (New Type)

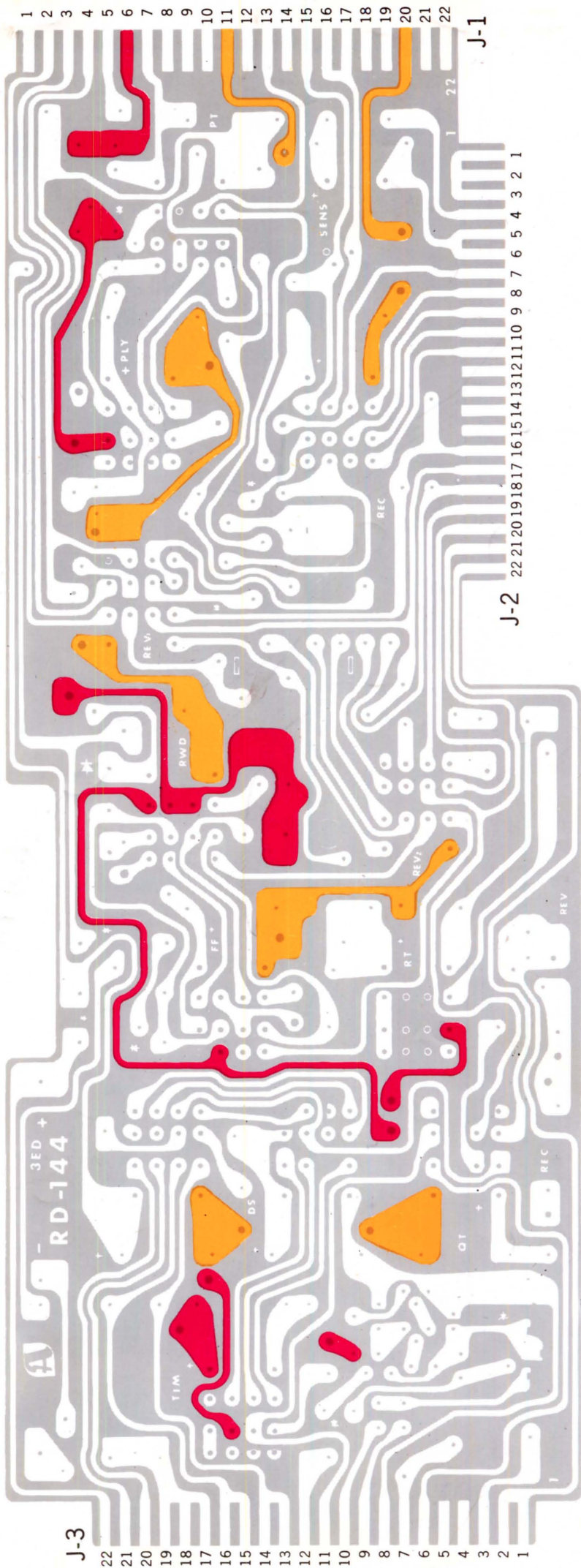

YELLOW...NEGATIVE, RED...POSITIVE (STOP CONDITION) BLACK POINT...CONNECTING POINT (CONNECTING BOTH SIDES OF THE BOARD)

check for Brake if want hold in Forward Bleg.

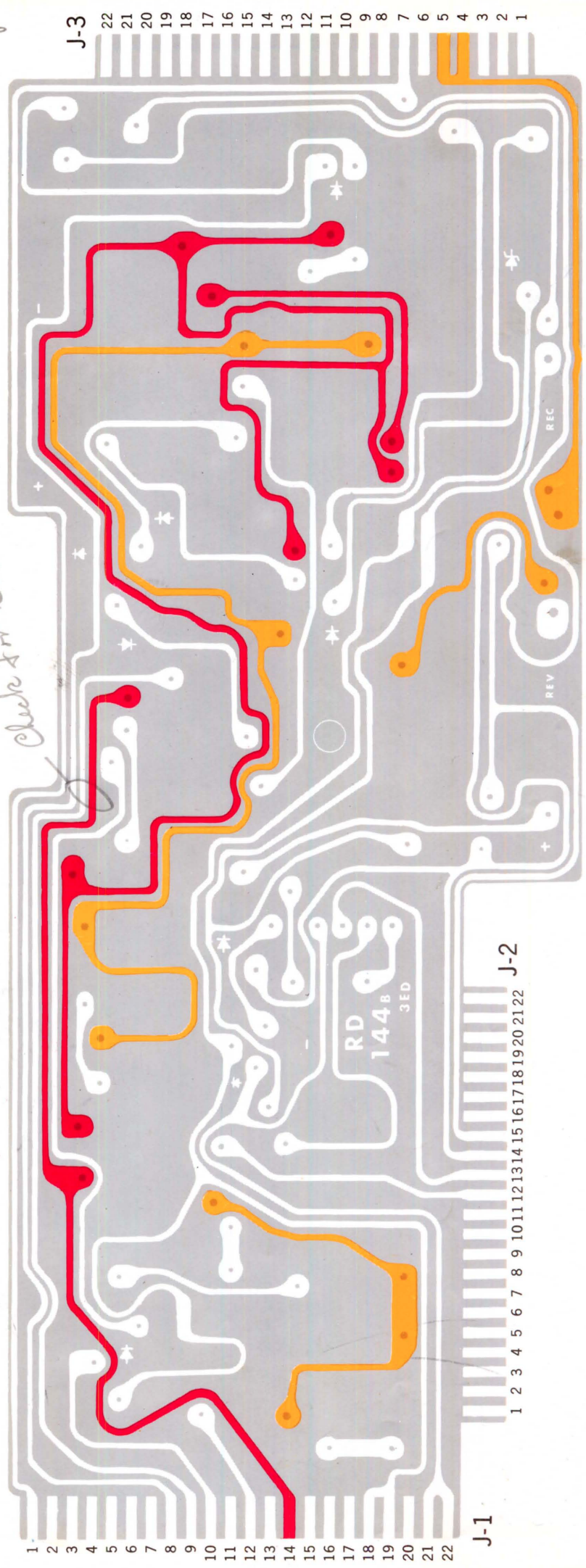

YELLOW...NEGATIVE.RED...POSITIVE(STOP CONDITION) BLACK POINT...CONNECTING POINT (CONNECTING BOTH SIDES OF THE BOARD)



REFERENCE FOR THE REPAIR II RD-144 System Control Board (Old Type)

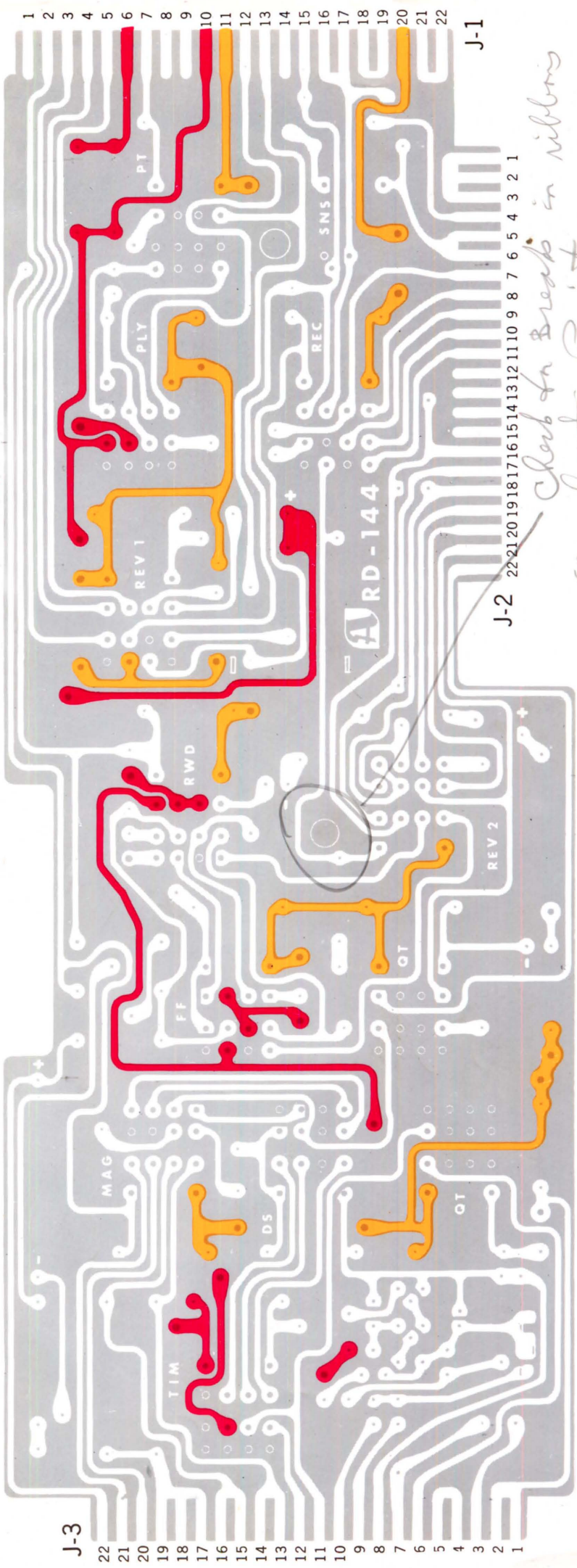

J-2 22 21 20 19 18 17 16 15 14 13 12 11 10 9 8 7 6 5 4 3 2 1

J-1

Check for Breaks in ribbons  
around this point

J-3

22

21

20

19

18

17

16

15

14

13

12

11

10

9

8

7

6

5

4

3

2

1

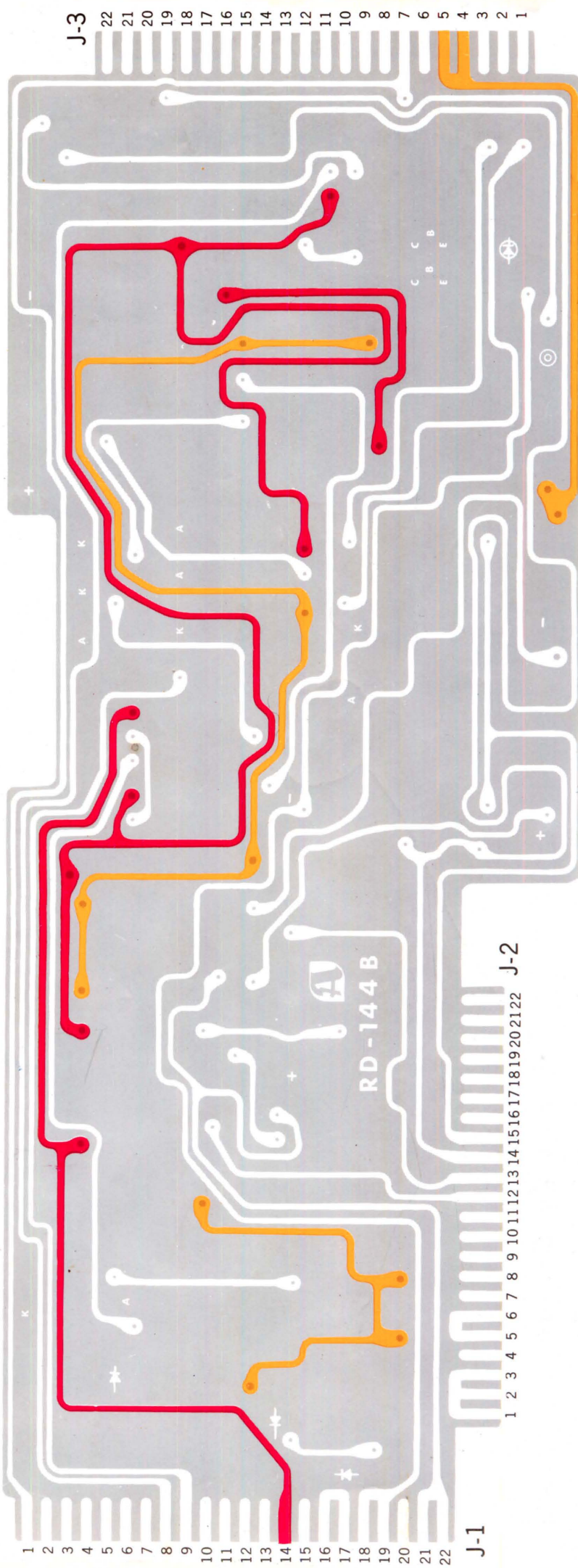

J-3

22  
21  
20  
19  
18  
17  
16  
15  
14  
13  
12  
11  
10  
9  
8  
7  
6  
5  
4  
3  
2  
1

1  
2  
3  
4  
5  
6  
7  
8  
9  
10  
11  
12  
13  
14  
15  
16  
17  
18  
19  
20  
21  
22

J-1

J-2

1 2 3 4 5 6 7 8 9 10 11 12 13 14 15 16 17 18 19 20 21 22

RD-144 B

C  
B  
E  
F

A

K

A

K

K

\*

+

\*

+

-

+

⊖

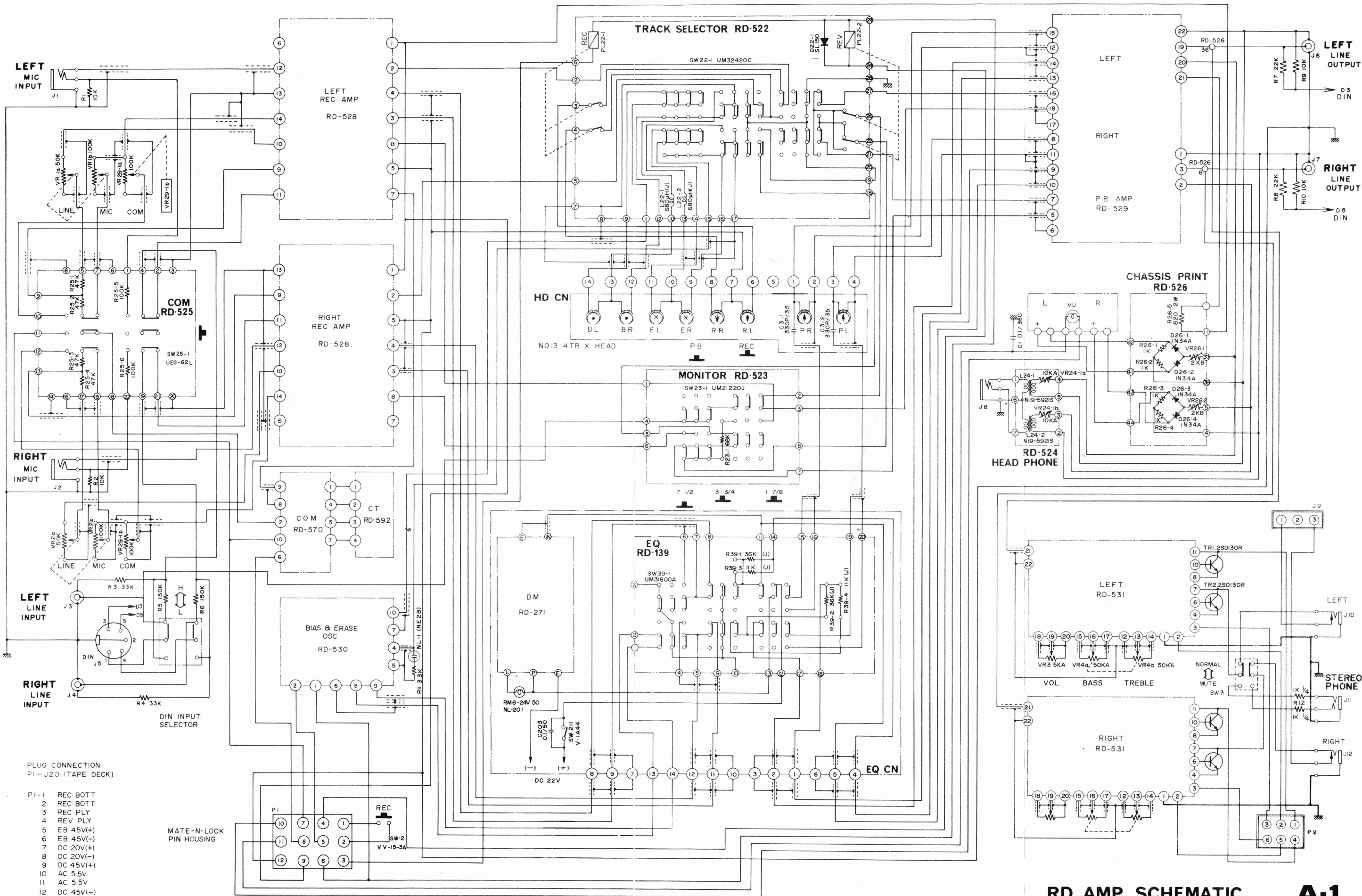

PLUG CONNECTION  
 P1-J201(TAPE DECK)

- P1-1 REC BOTT
- 2 REC BOTT
- 3 REC PLY
- 4 REV PLY
- 5 EB 45V(+)
- 6 EB 45V(-)
- 7 DC 20V(+)
- 8 DC 20V(-)
- 9 DC 45V(+)
- 10 AC 55V
- 11 AC 55V
- 12 DC 45V(-)

MATE-N-LOCK  
 PIN HOUSING

1-4 STEREO 3-2

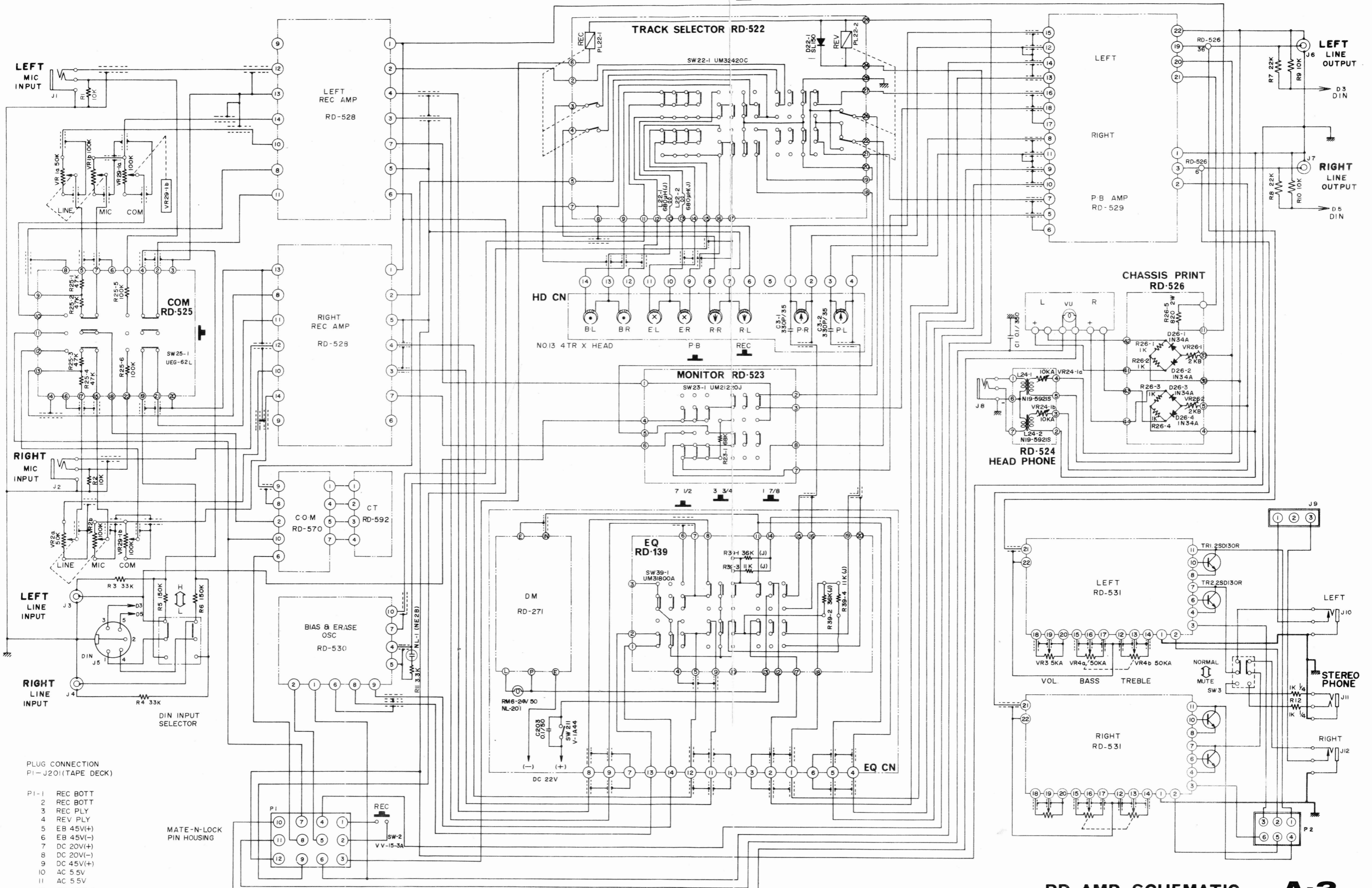

PLUG CONNECTION  
P1-J20(TAPE DECK)

- P1-1 REC BOTT
- 2 REC BOTT
- 3 REC PLY
- 4 REV PLY
- 5 EB 45V(+)
- 6 EB 45V(-)
- 7 DC 20V(+)
- 8 DC 20V(-)
- 9 DC 45V(+)
- 10 AC 55V
- 11 AC 55V
- 12 DC 45V(-)

MATE-N-LOCK  
PIN HOUSING

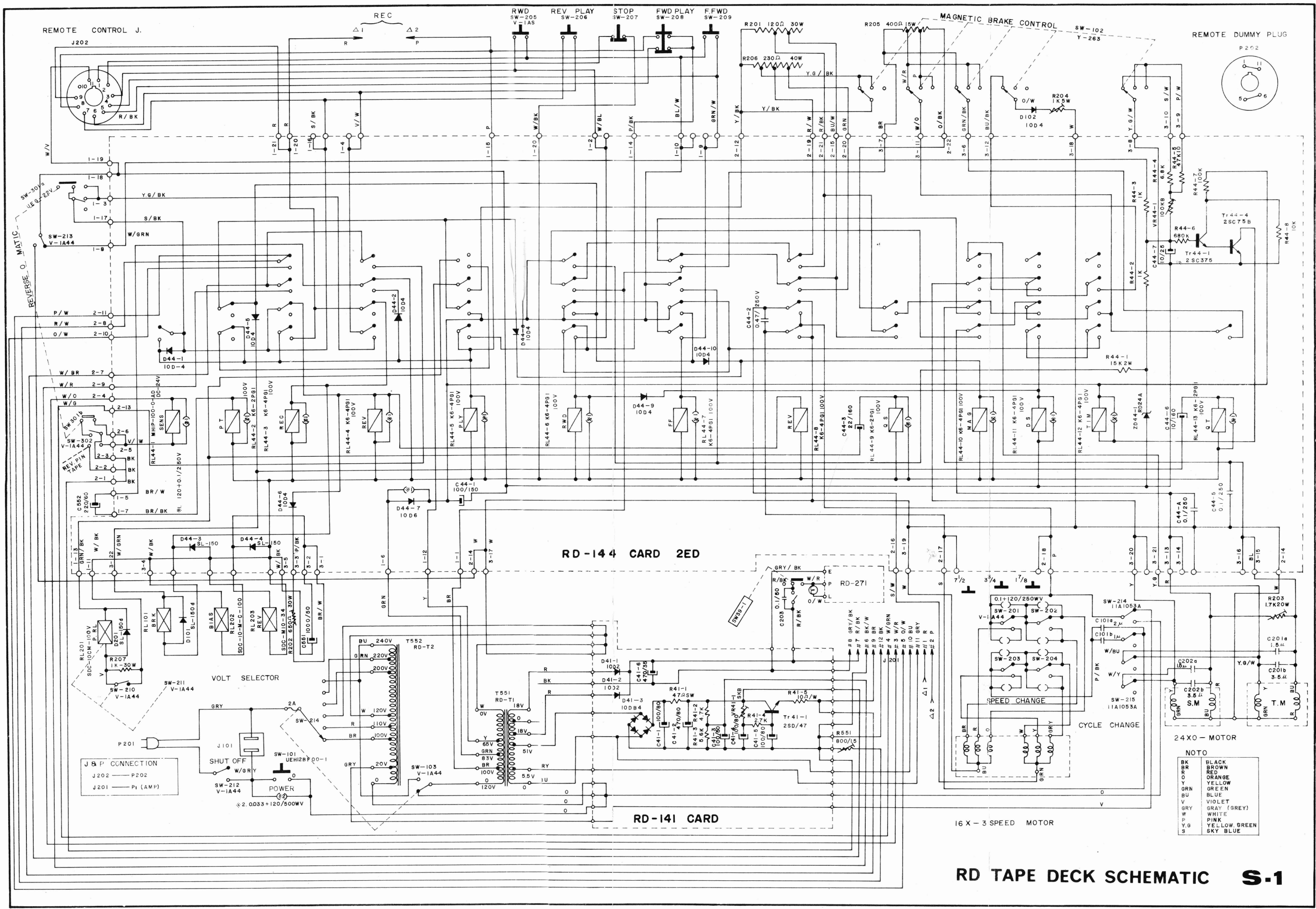

RD-144 CARD 2ED

RD-141 CARD

NOTE

BK	BLACK
BR	BROWN
DR	RED
OR	ORANGE
Y	YELLOW
GRN	GREEN
BU	BLUE
V	VIOLET
GRY	GRAY (GREY)
W	WHITE
P	PINK
Y/G	YELLOW GREEN
S	SKY BLUE

RD TAPE DECK SCHEMATIC S-1

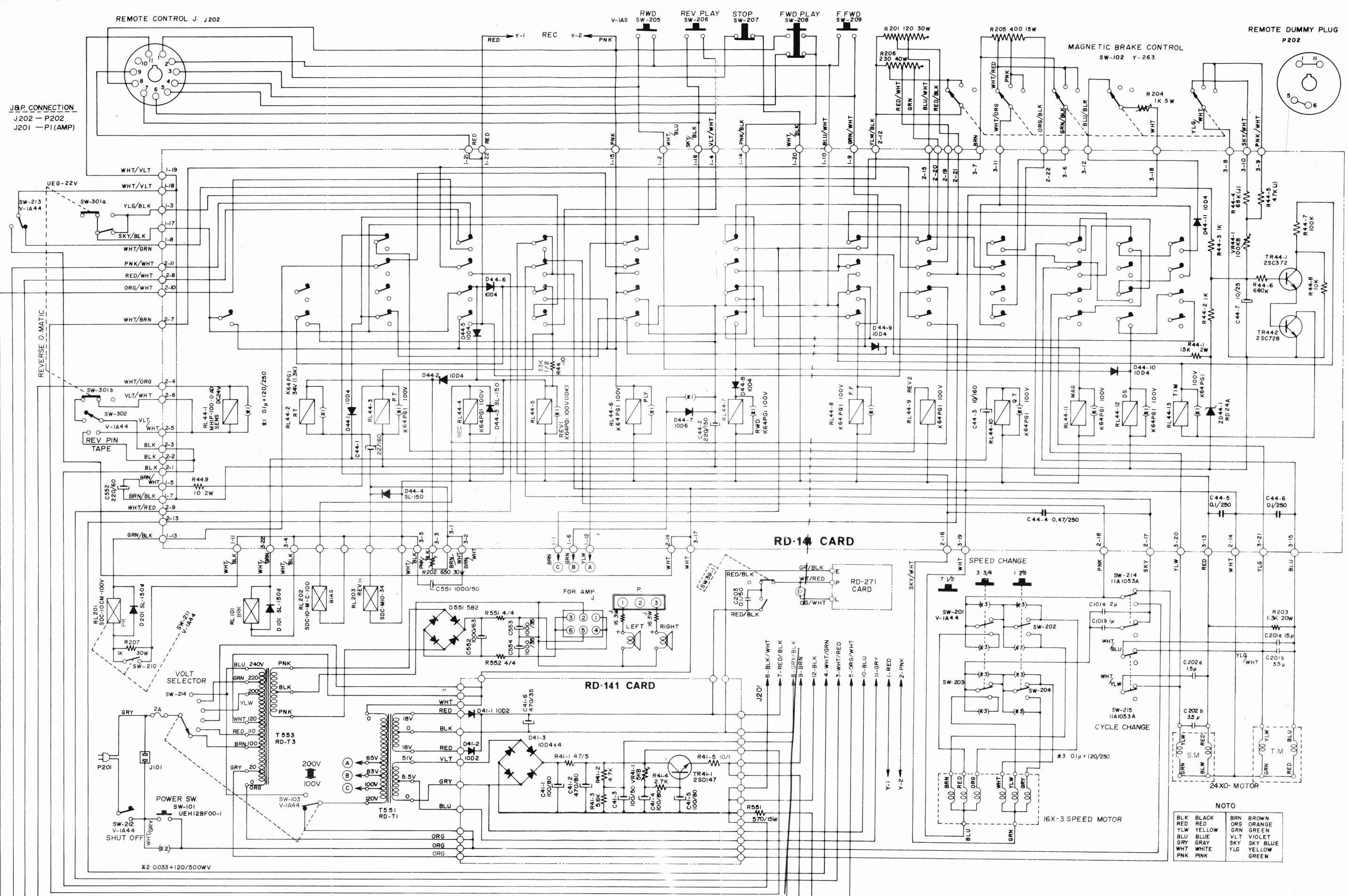

J&P CONNECTION  
 J202 - P202  
 J201 - P1 (AMP)

NOTE

BLK	BLACK	BRN	BROWN
RED	RED	ORG	ORANGE
YLG	YELLOW	GRN	GREEN
BLU	BLUE	VLT	VIOLET
GRY	GRAY	SKY	SKY BLUE
WHT	WHITE	YLG	YELLOW
PNK	PINK		

RD TAPE DECK SCHEMATIC S-2

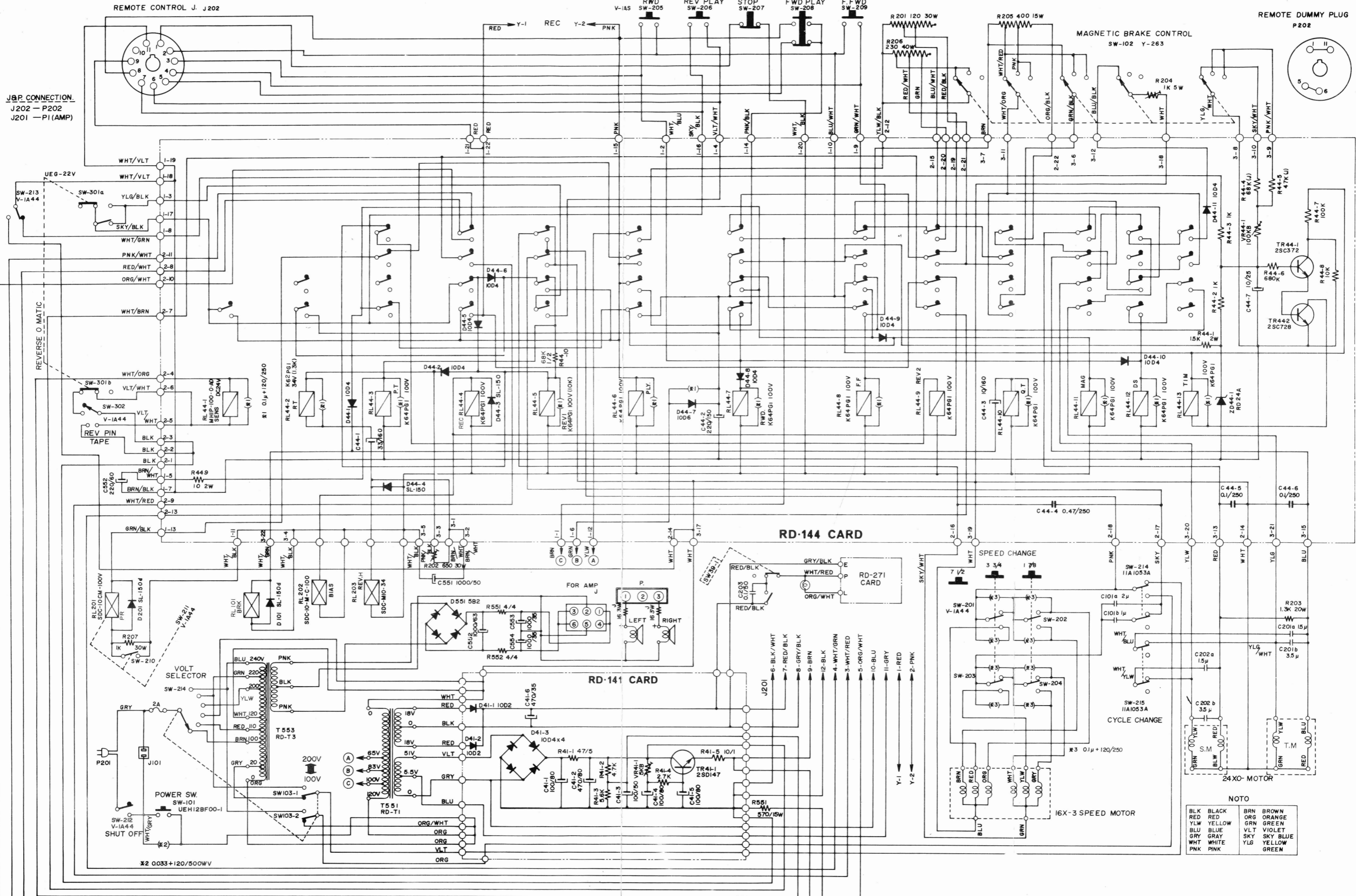

J&P CONNECTION  
 J202 - P202  
 J201 - PI (AMP)

NOTO

BLK	BLACK	BRN	BROWN
RED	RED	ORG	ORANGE
YLW	YELLOW	GRN	GREEN
BLU	BLUE	VLV	VIOLET
GRY	GRAY	SKY	SKY BLUE
WHT	WHITE	YLG	YELLOW GREEN
PNK	PINK		

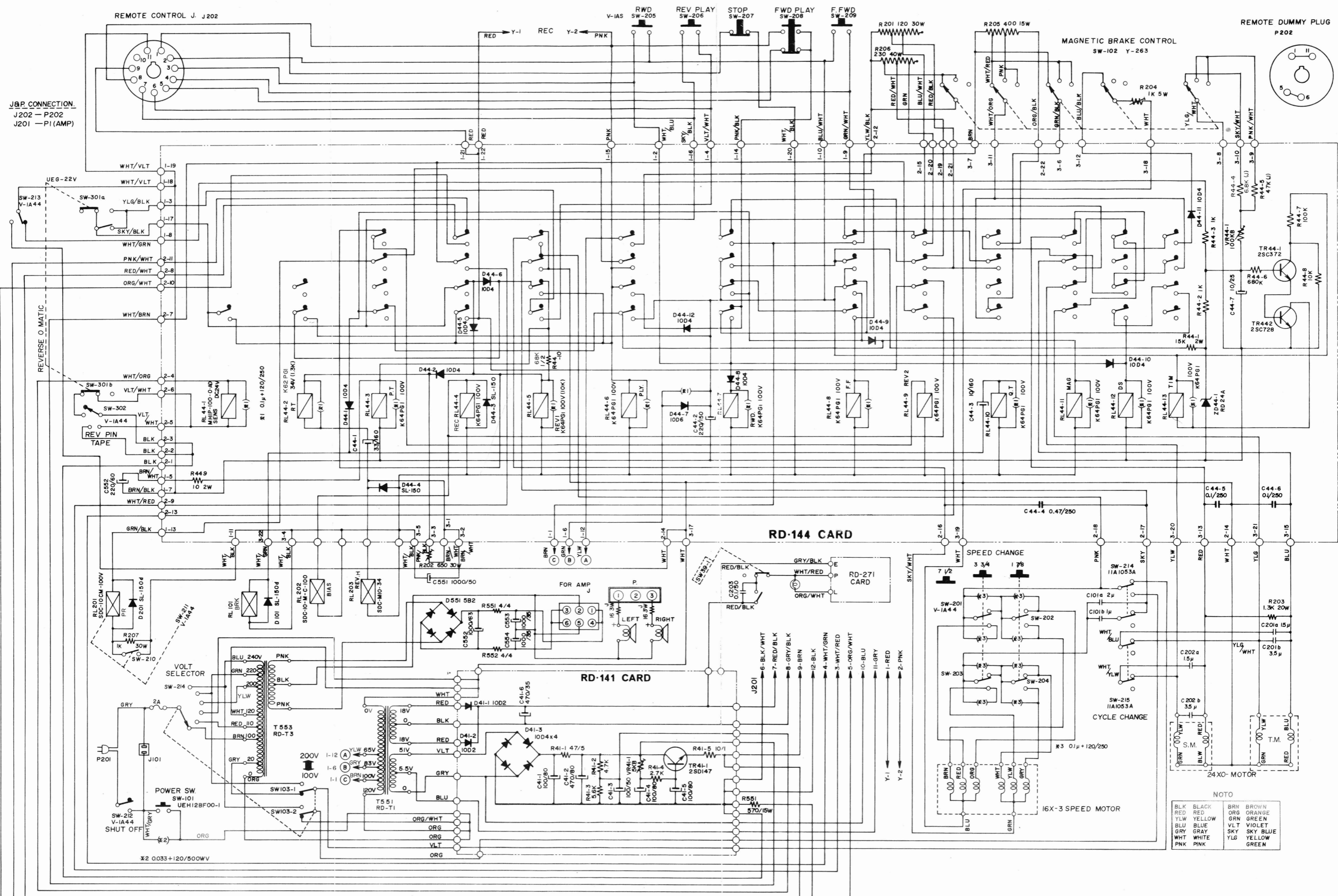

J&P CONNECTION  
 J202 - P202  
 J201 - P1 (AMP)

REMOTE DUMMY PLUG  
 P202

RD-144 CARD

RD-141 CARD

SPEED CHANGE

CYCLE CHANGE

NOTO

BLK	BLACK	BRN	BROWN
RED	RED	ORG	ORANGE
YLG	YELLOW	GRN	GREEN
BLU	BLUE	VLT	VIOLET
GRY	GRAY	SKY	SKY BLUE
WHT	WHITE	YLS	YELLOW GREEN
PNK	PINK		

RD TAPE DECK SCHEMATIC S-4



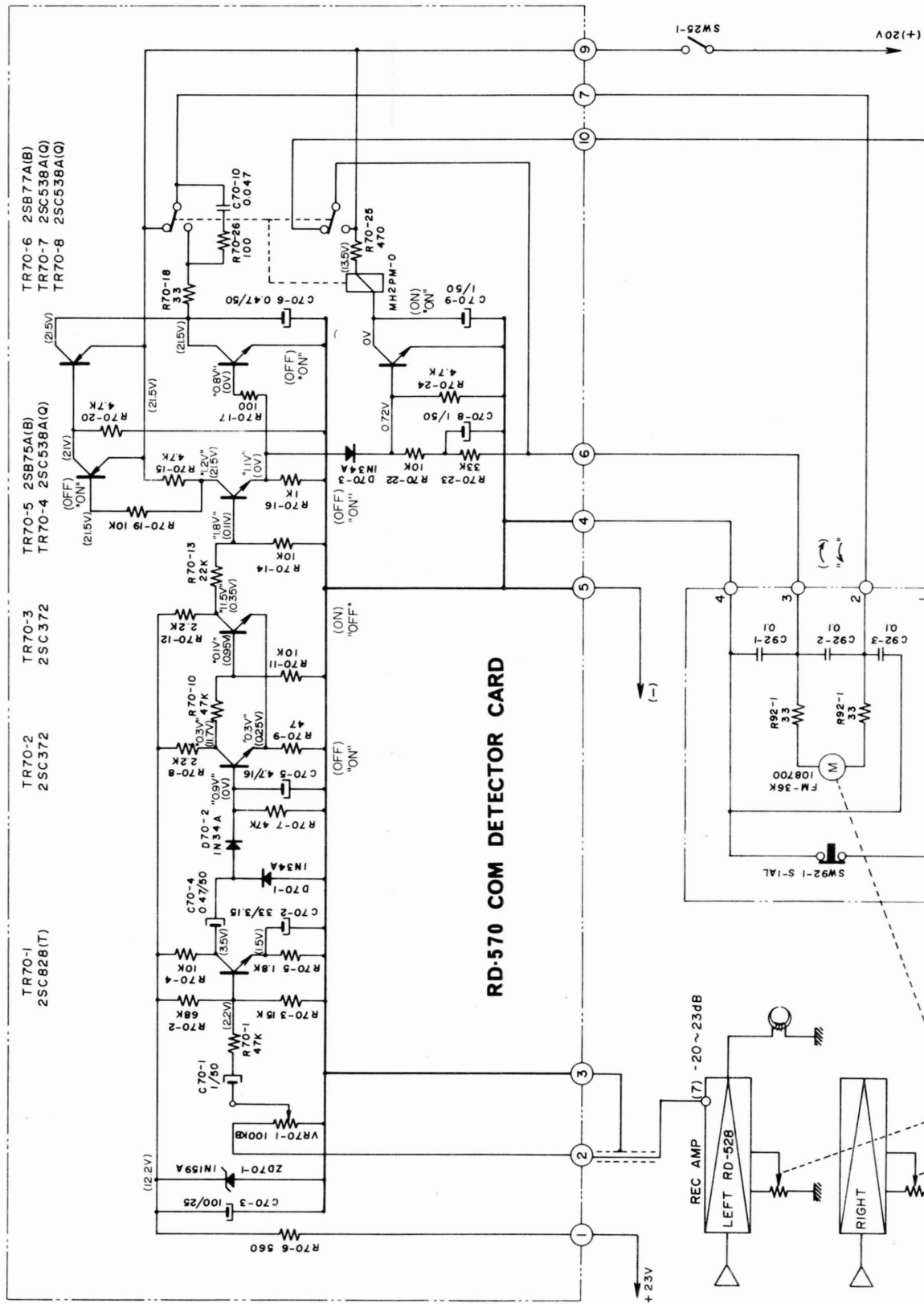

**RD-570 COM DETECTOR CARD**

**RD-592 COM MECHANIC BLOCK**

( ) SHOWING NON-INPUT SIGNAL CONDITIO  
 " " SHOWING AUTOMATIC O VU SET  
 WHILE MOTOR ROTATES (when more than Ovu signal input)



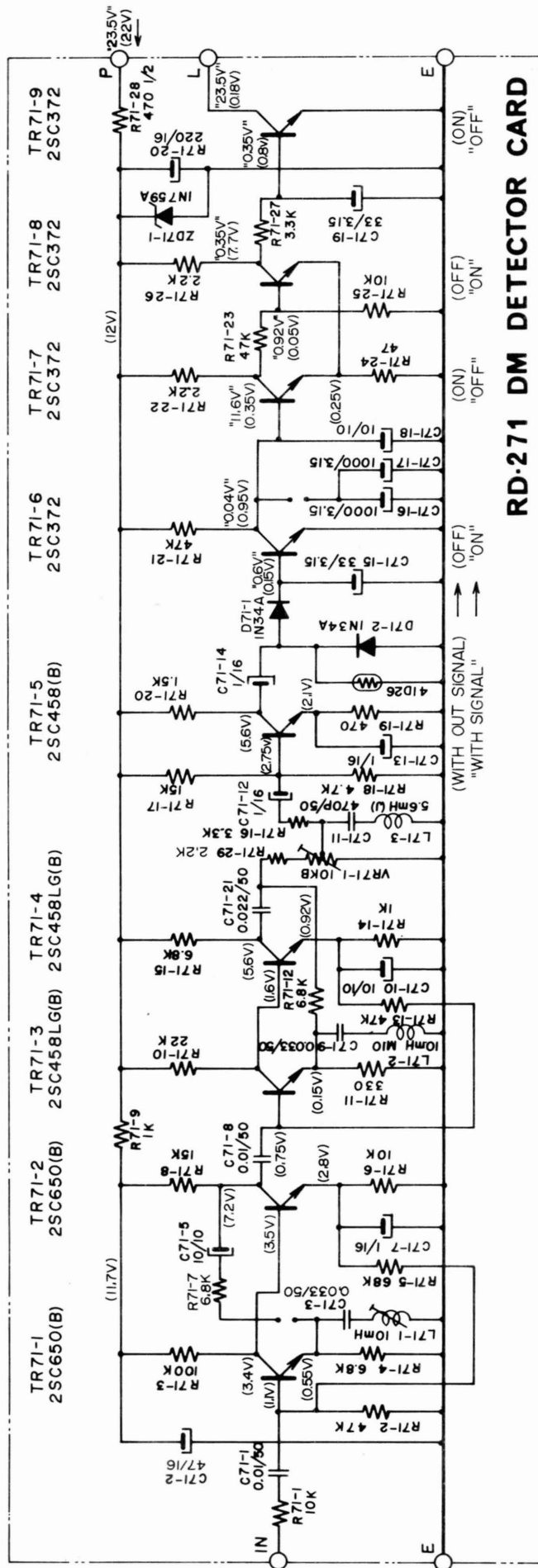

**RD-271 DM DETECTOR CARD**

( ) SHOWING LAMP IS ON  
 " " SHOWING LAMP IS OFF

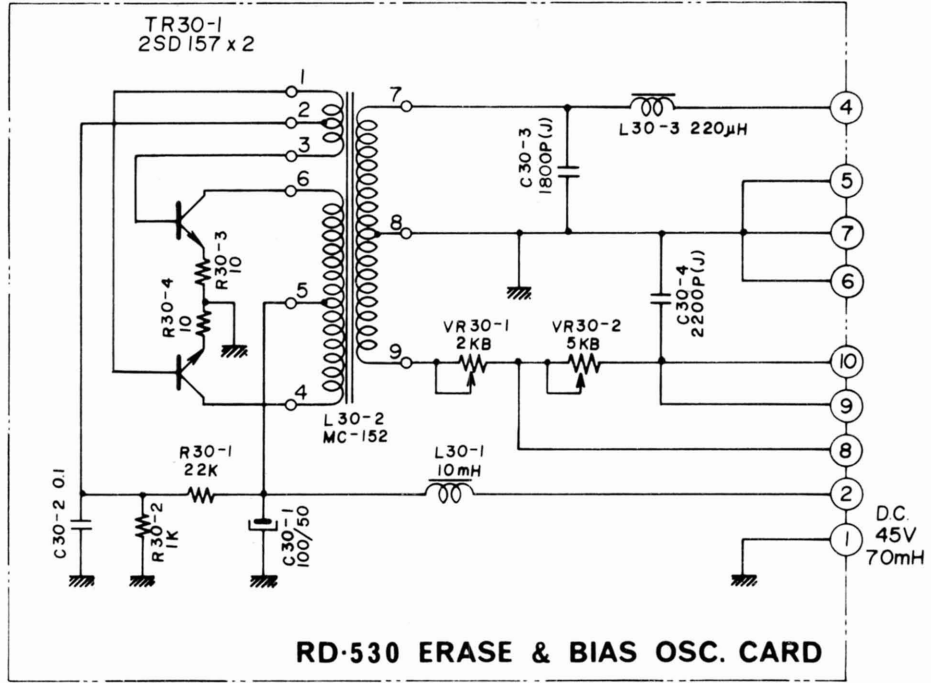

**O-1**

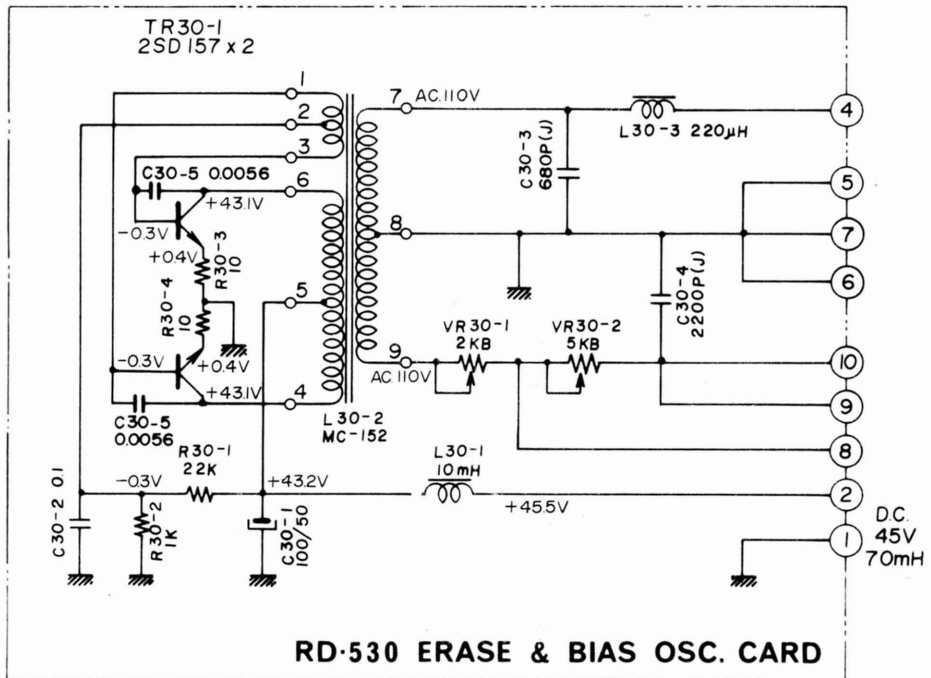

**O-2**

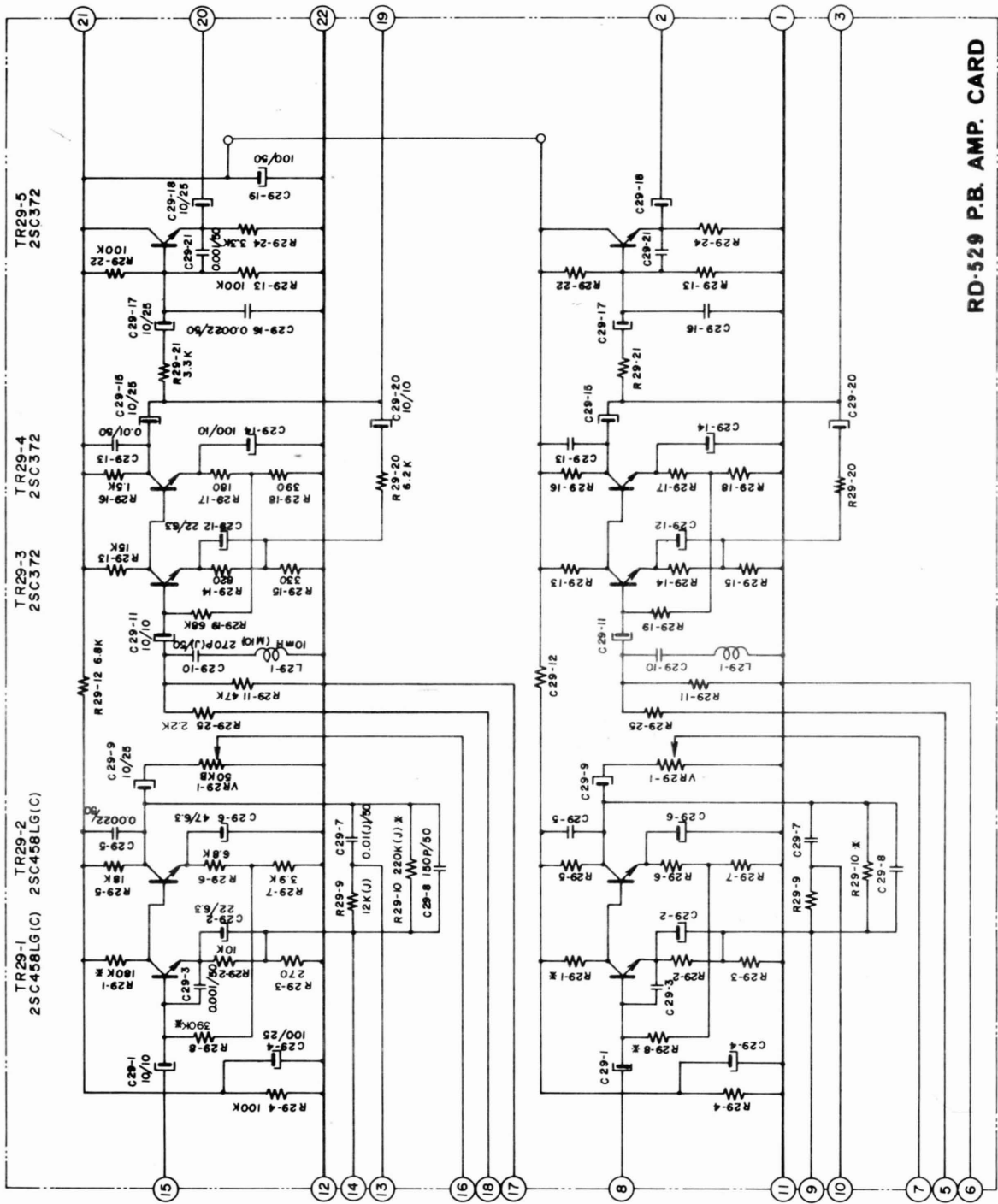

RD-529 P.B. AMP. CARD

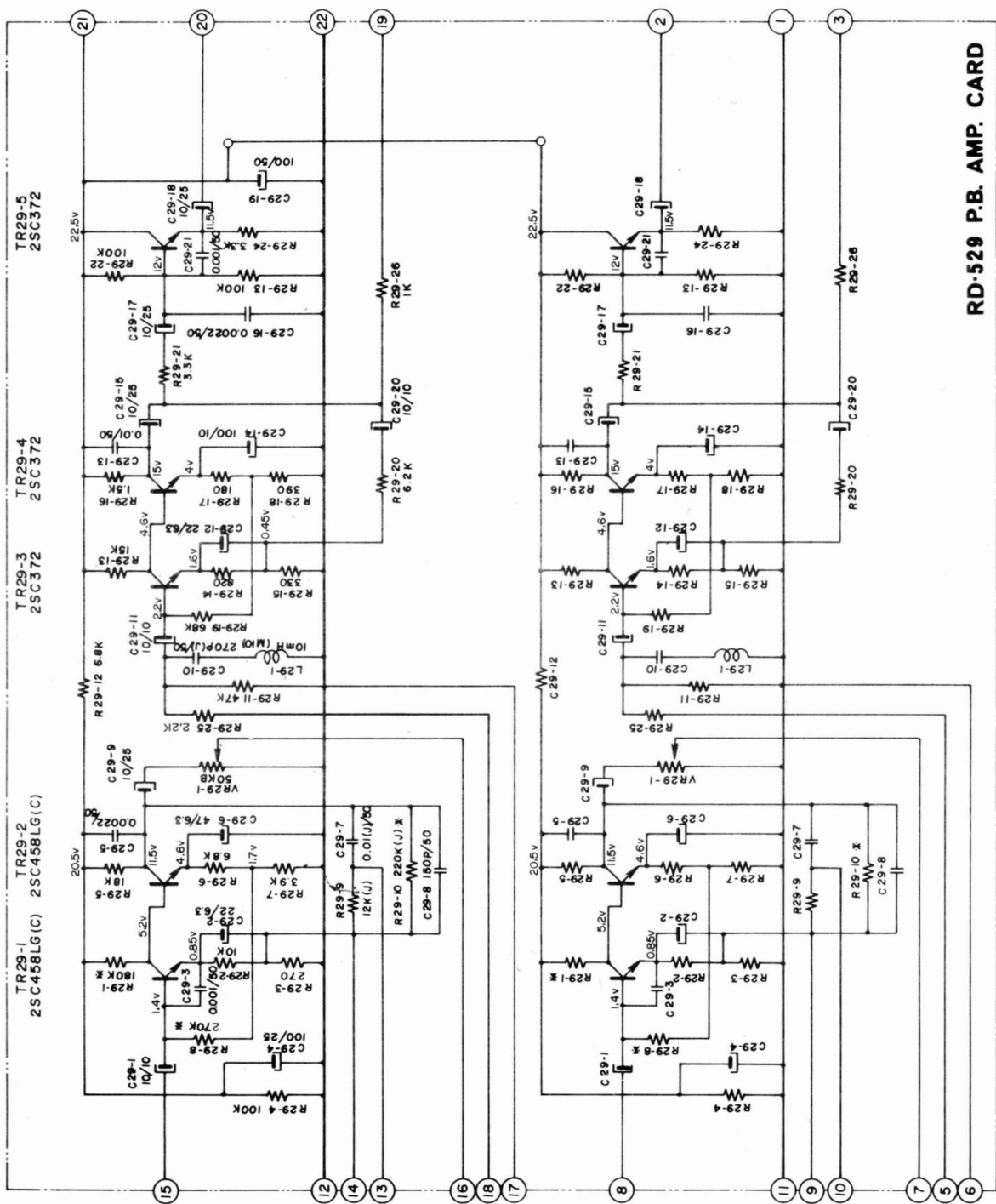

RD-529 P.B. AMP. CARD

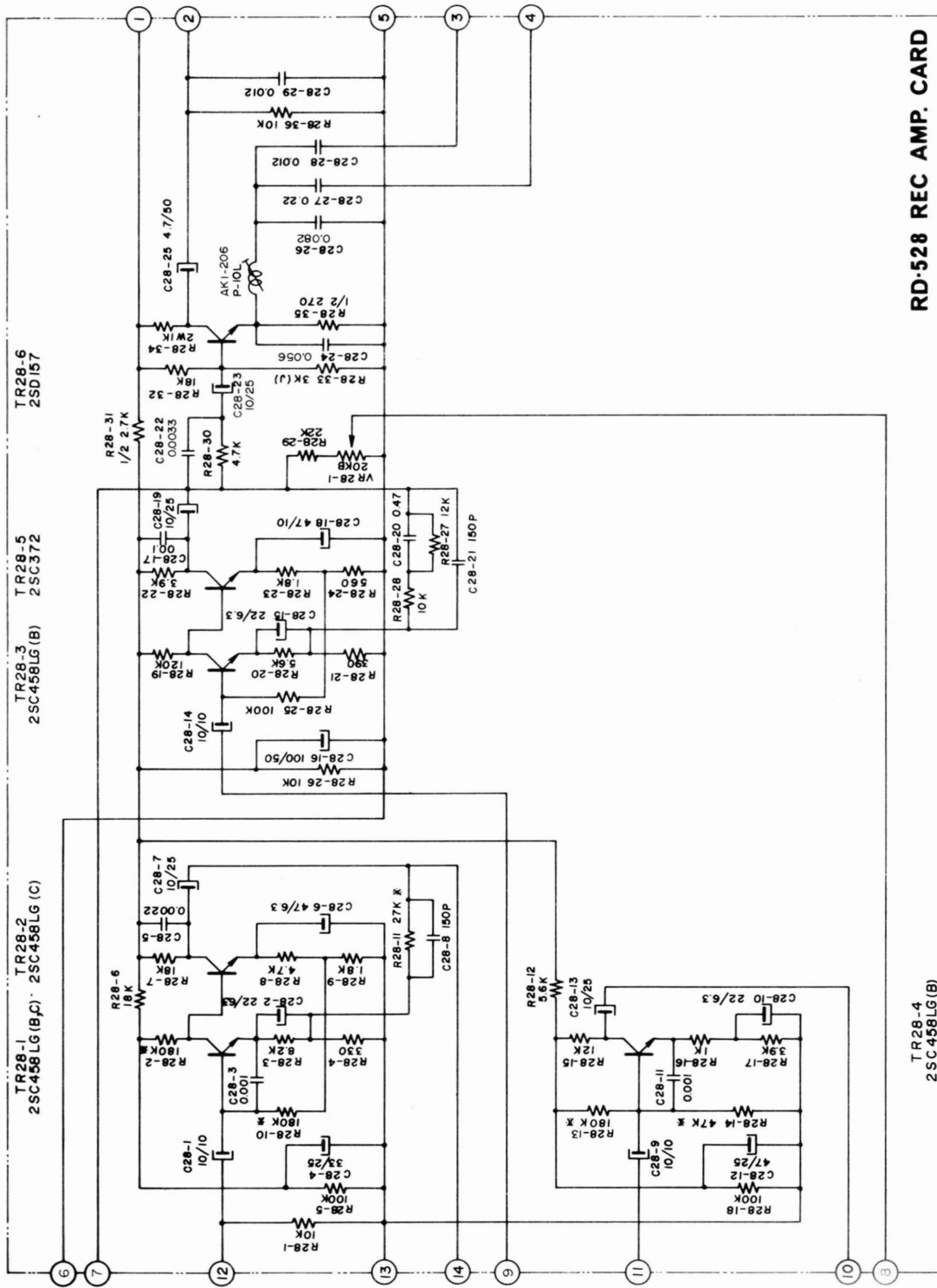

RD-528 REC AMP. CARD

TR28-4  
2SC458LG(B)

R-1

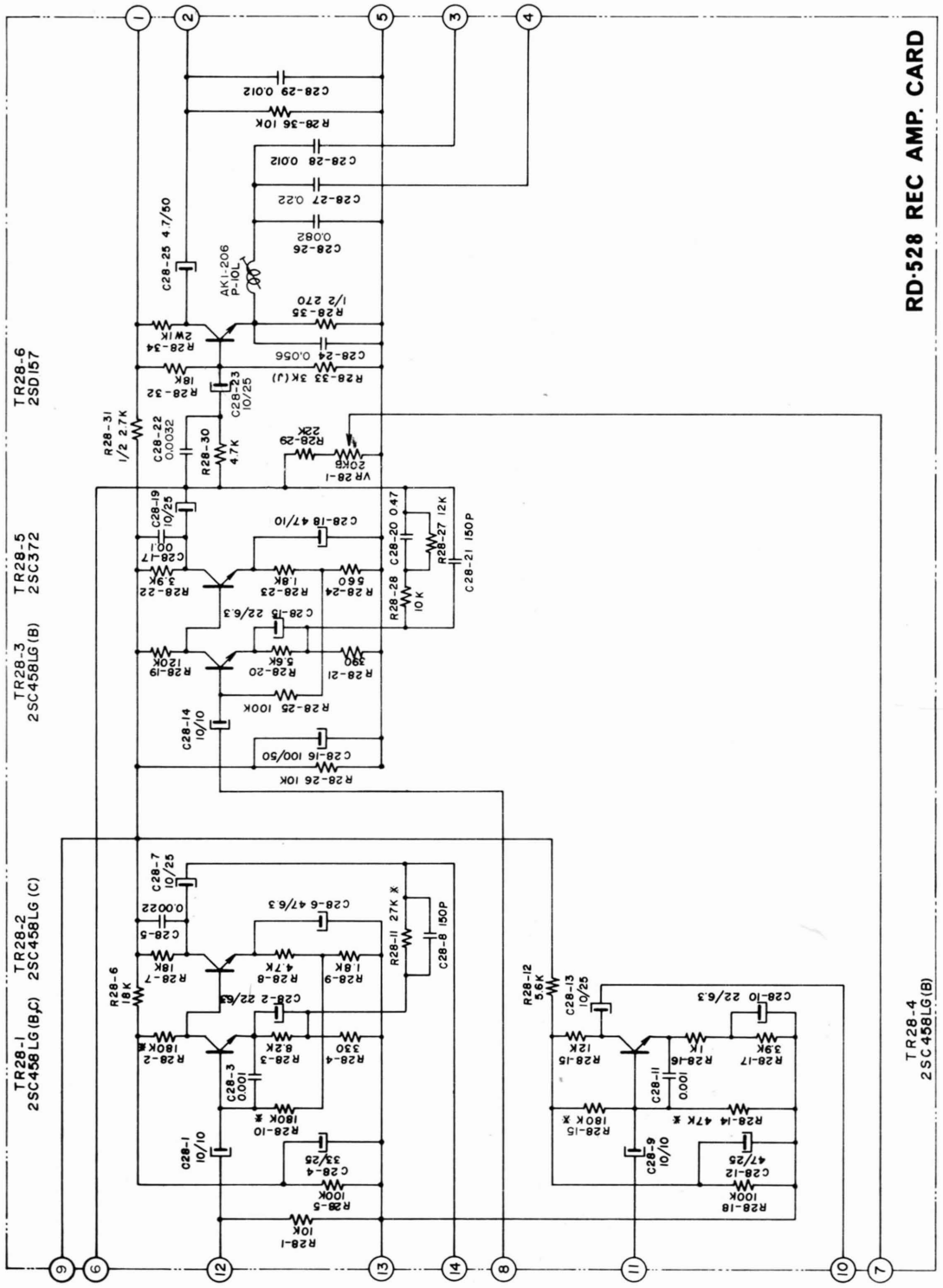

RD-528 REC AMP. CARD

TR28-4  
2SC458LG (B)



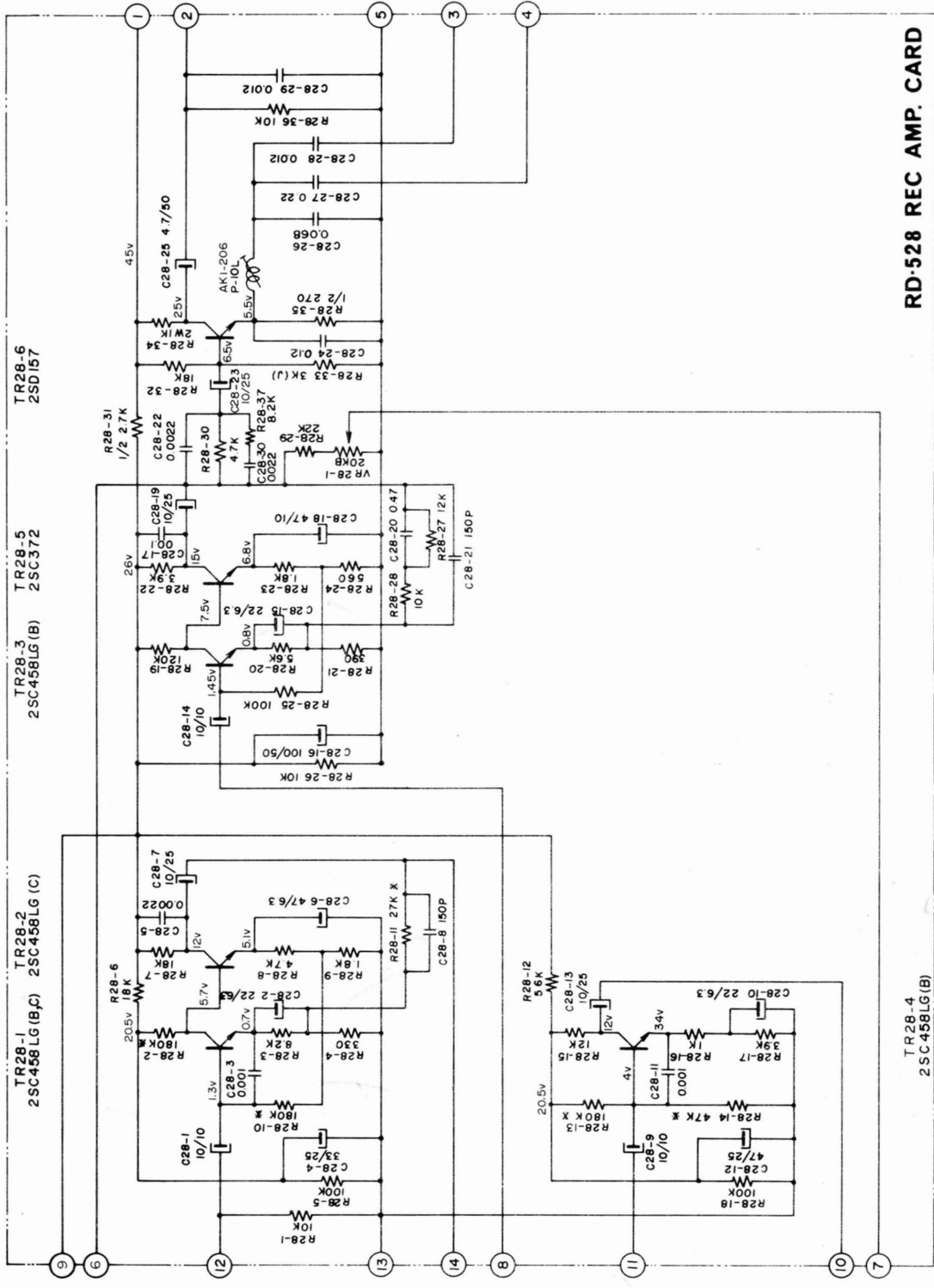

RD-528 REC AMP. CARD

TR28-4  
2SC458LG(B)

R-3

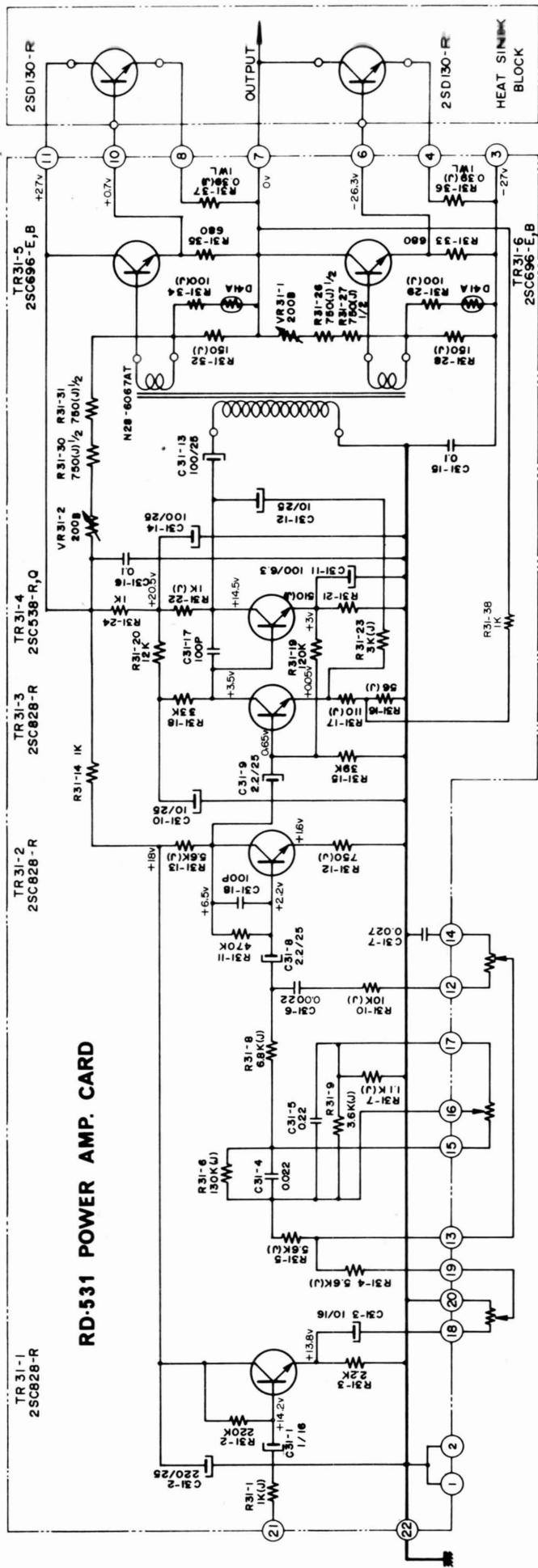

**RD-531 POWER AMP. CARD**

**W-1**



AKAI ELECTRIC CO., LTD.  
AKAI TRADING CO., LTD.

12, 2-chome, Higashi-Kojiya,  
Ohta-ku, Tokyo, Japan

Price ¥1800.00  
\$ 5.00

Printed in Japan

AKAI ELECTRIC CO., LTD.

No.....

Tokyo: April 24, 1970

Model X-360 and X-360D

Subject: Pinch Wheel Solenoid Burning Out

When the Solenoid is replaced, it is necessary to check the following; ( Refer to Page 14 of X-360 Service Manual )

- \* During Rec./Play mode, the two switches, #SW-210 and #SW-211, should be depressed and open.
- \* Especially, adjustment and physical location of #SW-210 and Screw #F fastening.

In many cases of the captioned trouble, #SW-210 is not fully depressed when the Tape Shifter Lever raises during Rec./Play mode. Then, over-rated current (100 V) will continuously fed to the Solenoid. During normal operation, the rated current should be 20 V after #SW-210 has been properly activated or opened.

We have learned that in most cases Screw #F loosened during transit and SW-210 was then improperly positioned.

AKAI ELECTRIC CO., LTD.

3.y.

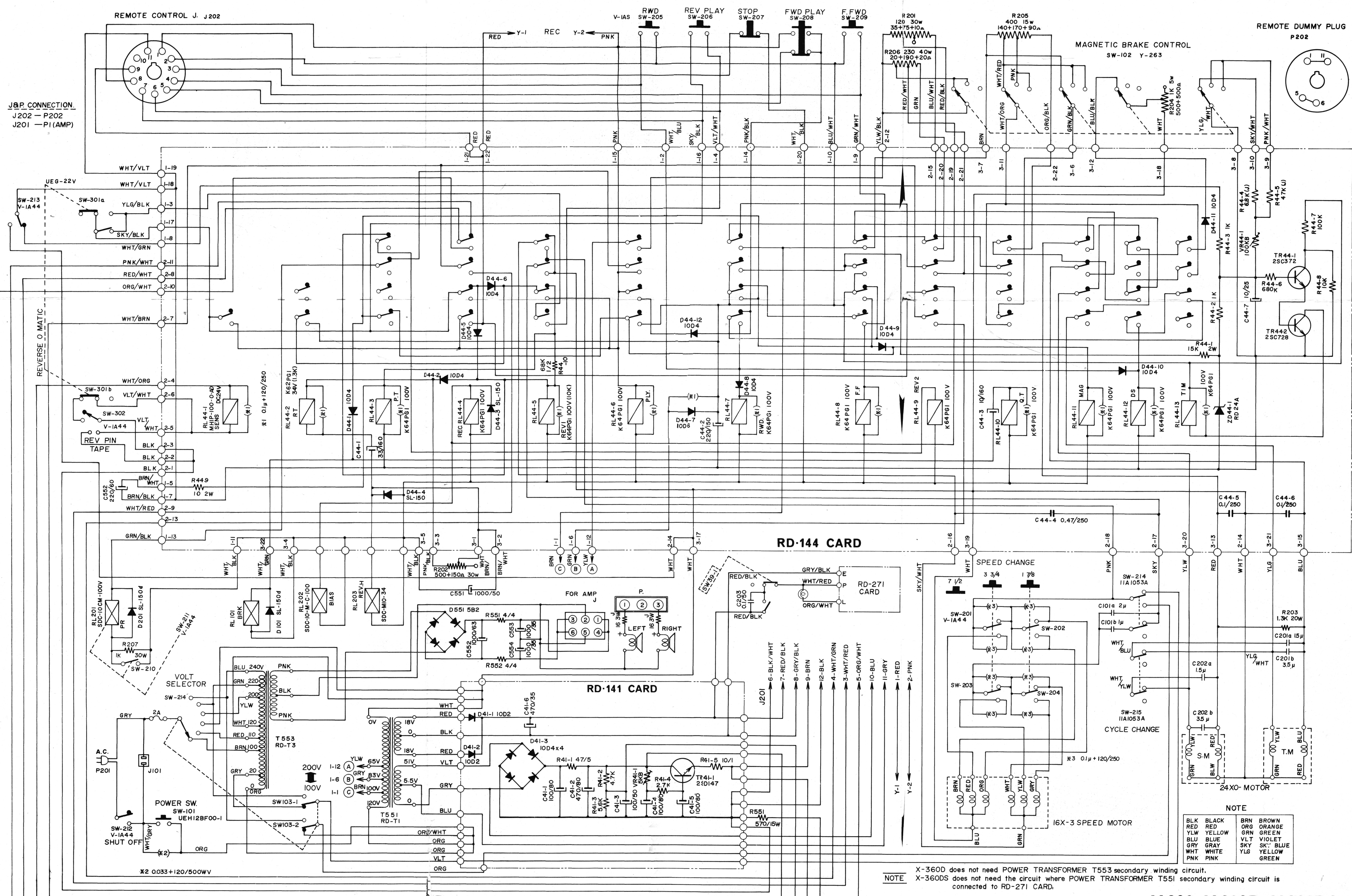

J&P CONNECTION  
 J202 - P202  
 J201 - P1 (AMP)

NOTE

BLK	BLACK	BRN	BROWN
RED	RED	ORG	ORANGE
BLU	BLUE	GRN	GREEN
YLG	YELLOW	VLT	VIOLET
GRY	GRAY	SKY	SKY BLUE
WHT	WHITE	YLG	YELLOW
PNK	PINK		

NOTE X-360D does not need POWER TRANSFORMER T553 secondary winding circuit.  
 NOTE X-360DS does not need the circuit where POWER TRANSFORMER T551 secondary winding circuit is connected to RD-271 CARD.

NO.4-1 X-360, X-360D, X-360DS  
 TAPE DECK SCHEMATIC 13616205

1-4 STEREO 3-2

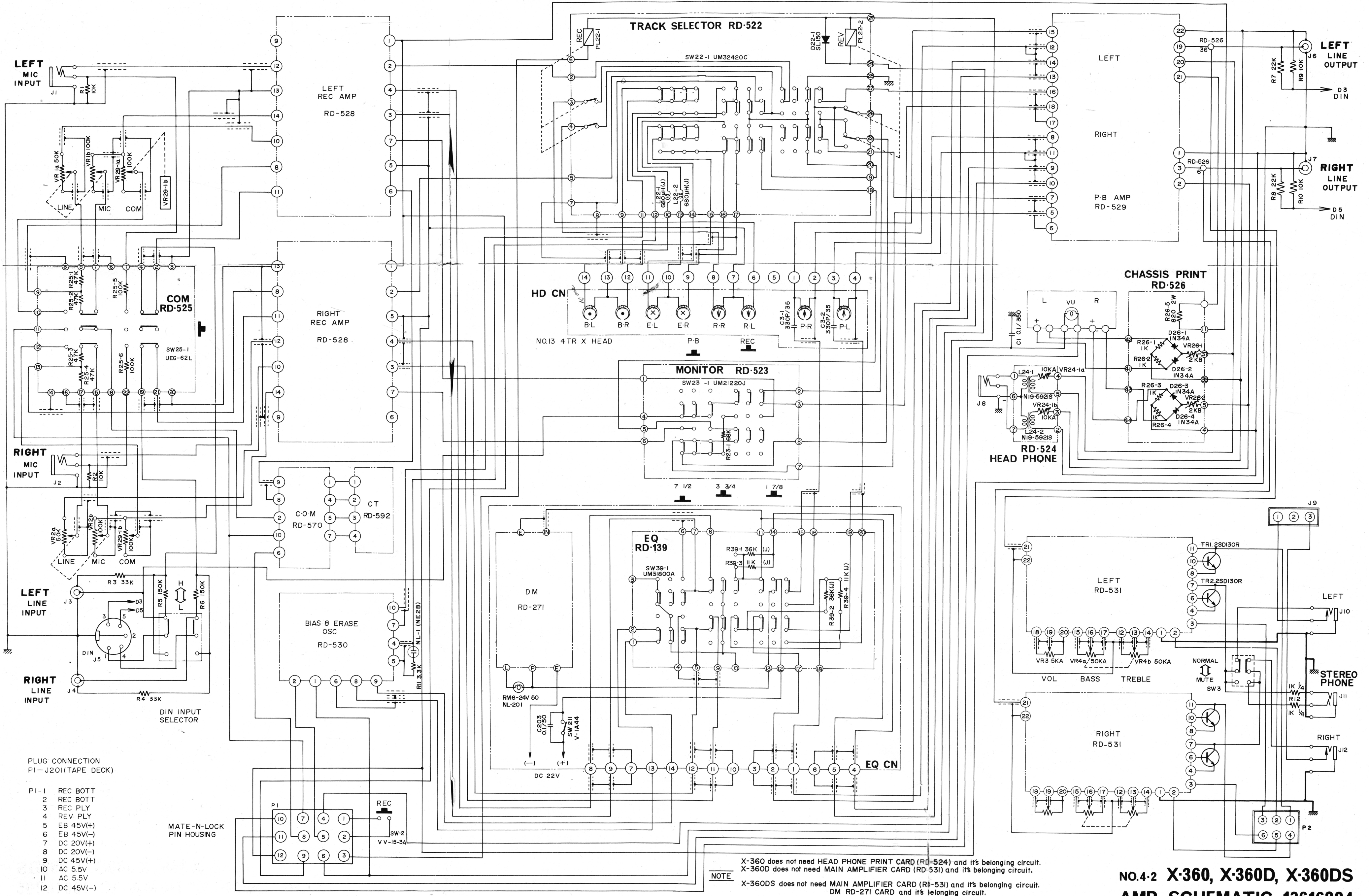

PLUG CONNECTION  
P1-J201(TAPE DECK)

- P1-1 REC BOTT
- 2 REC BOTT
- 3 REC PLY
- 4 REV PLY
- 5 EB 45V(+)
- 6 EB 45V(-)
- 7 DC 20V(+)
- 8 DC 20V(-)
- 9 DC 45V(+)
- 10 AC 5.5V
- 11 AC 5.5V
- 12 DC 45V(-)

MATE-N-LOCK  
PIN HOUSING

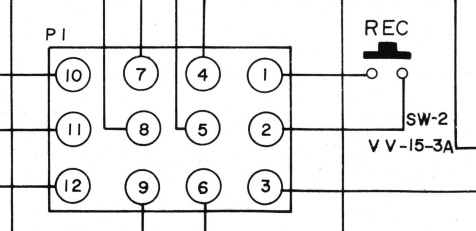

**NOTE**  
X-360 does not need HEAD PHONE PRINT CARD (RD-524) and its belonging circuit.  
X-360D does not need MAIN AMPLIFIER CARD (RD-531) and its belonging circuit.  
X-360DS does not need MAIN AMPLIFIER CARD (RD-531) and its belonging circuit.  
DM RD-271 CARD and its belonging circuit.  
C.O.M. RD-525, RD-570, CT RD-592 CARD and their belonging circuit.

**NO.4-2 X-360, X-360D, X-360DS  
AMP. SCHEMATIC 13616224**

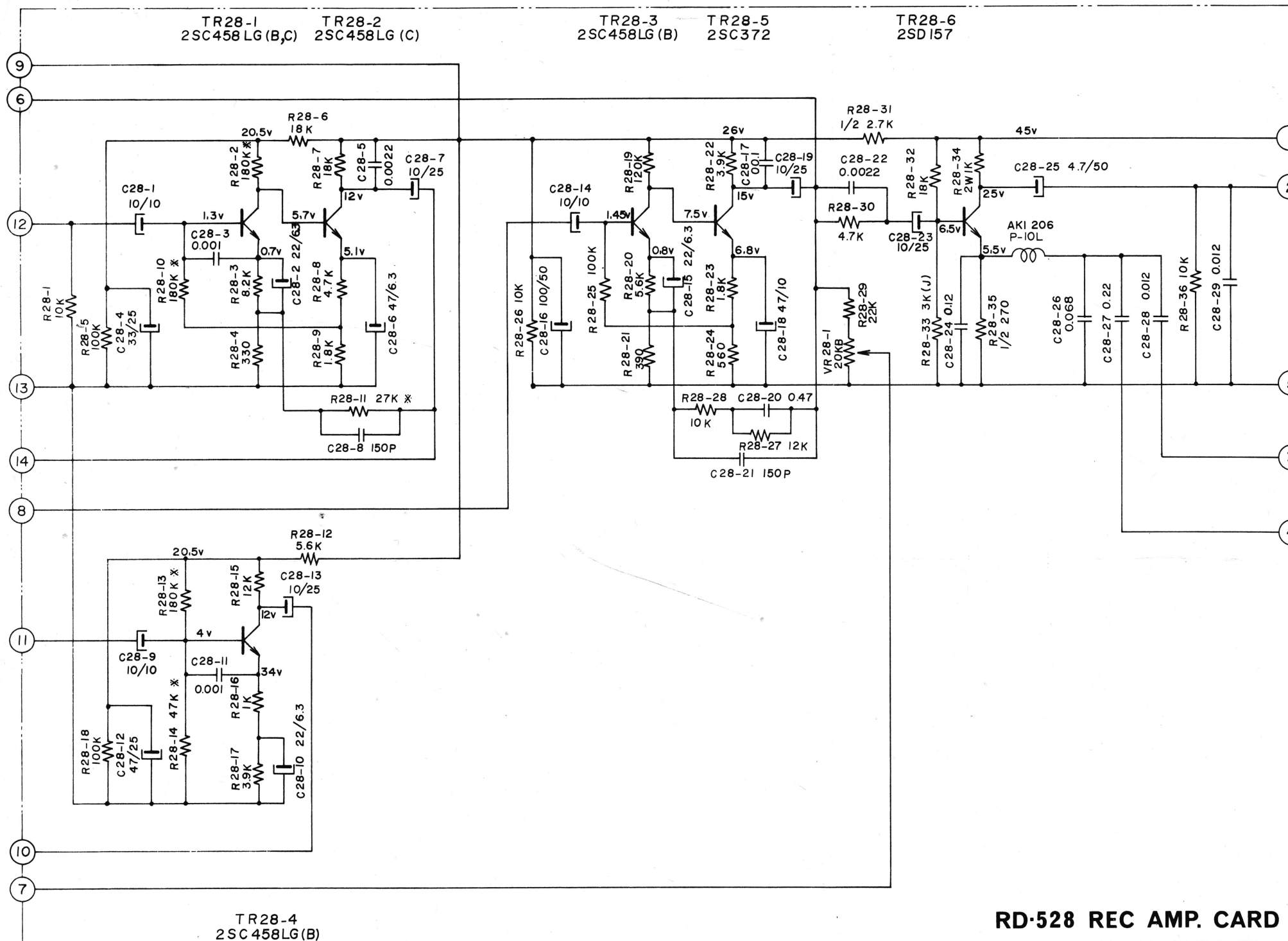

RD-528 REC AMP. CARD

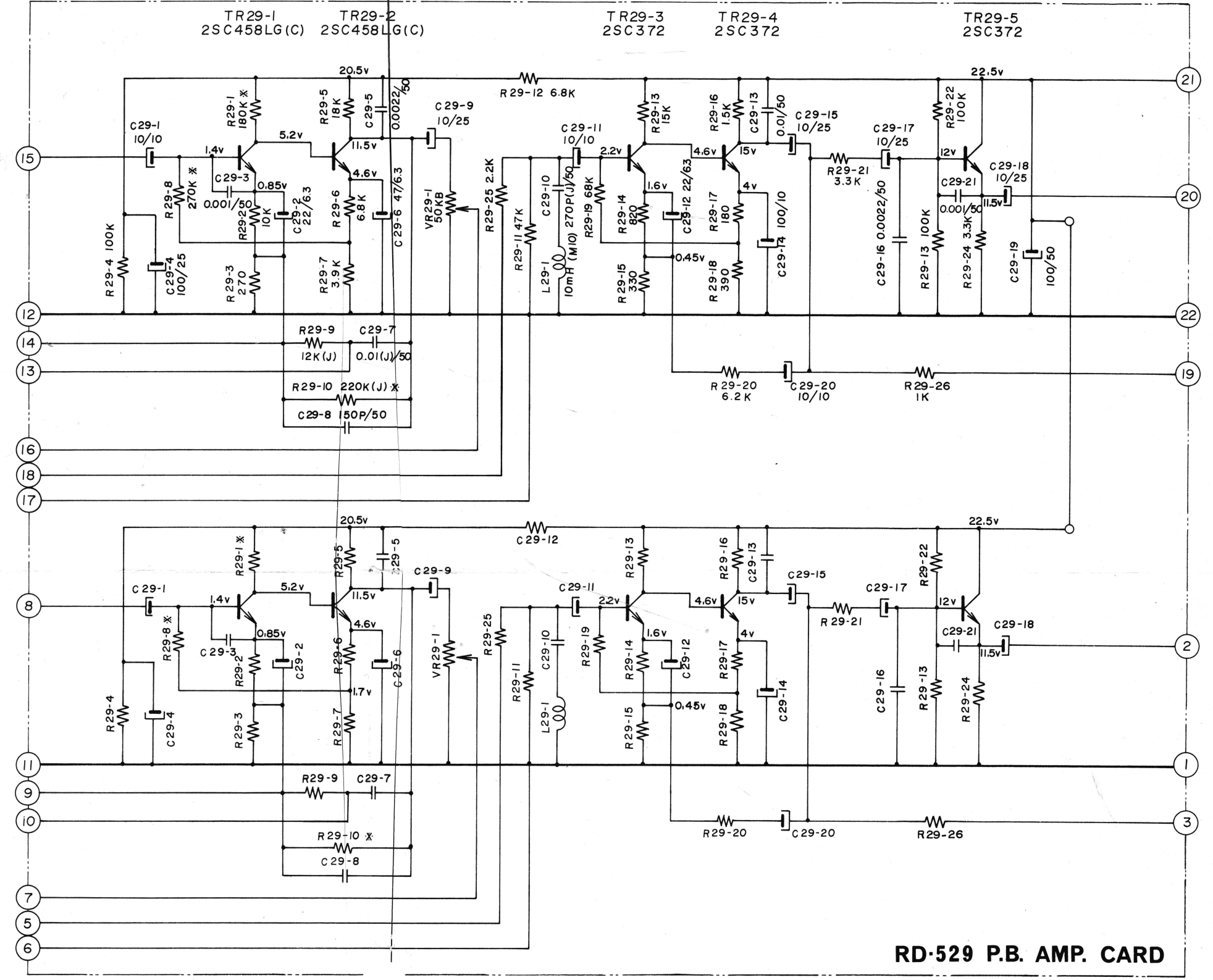

RD-529 P.B. AMP. CARD

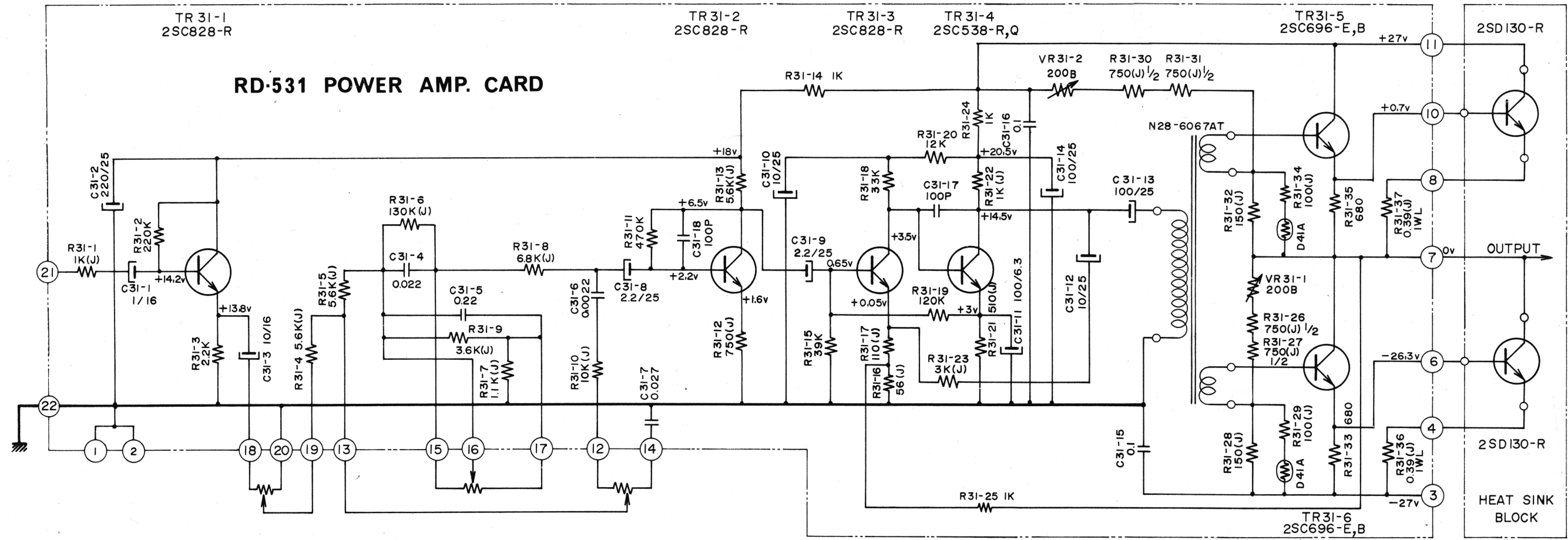

RD-531 POWER AMP. CARD

**NOTE**

RESISTOR  
X ----- NOISE LESS

RD-531 POWER AMP. CARD is not needed in X-360D and X-360DS.

NO. 4-3 X-360, X-360D, X-360DS  
AMP. CARD SCHEMATIC 13616164

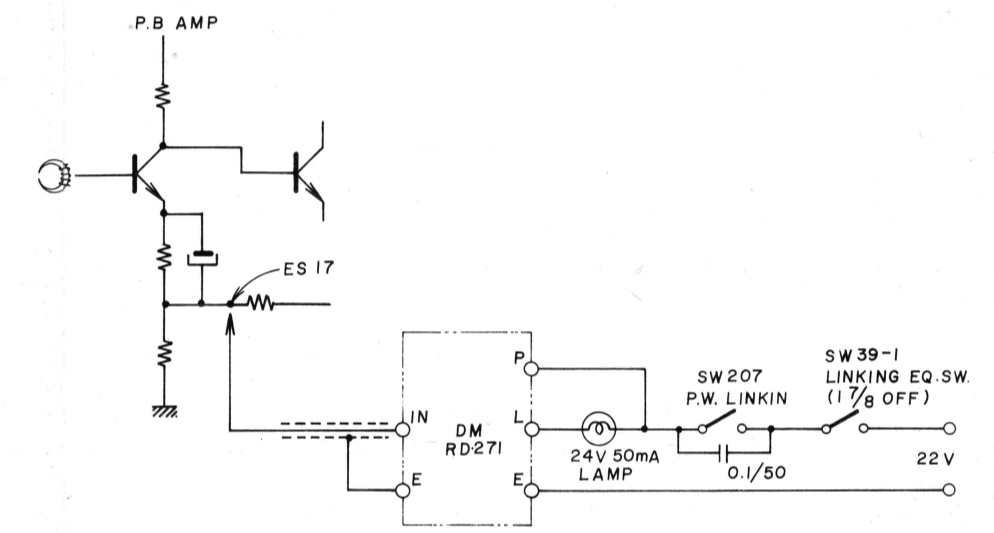
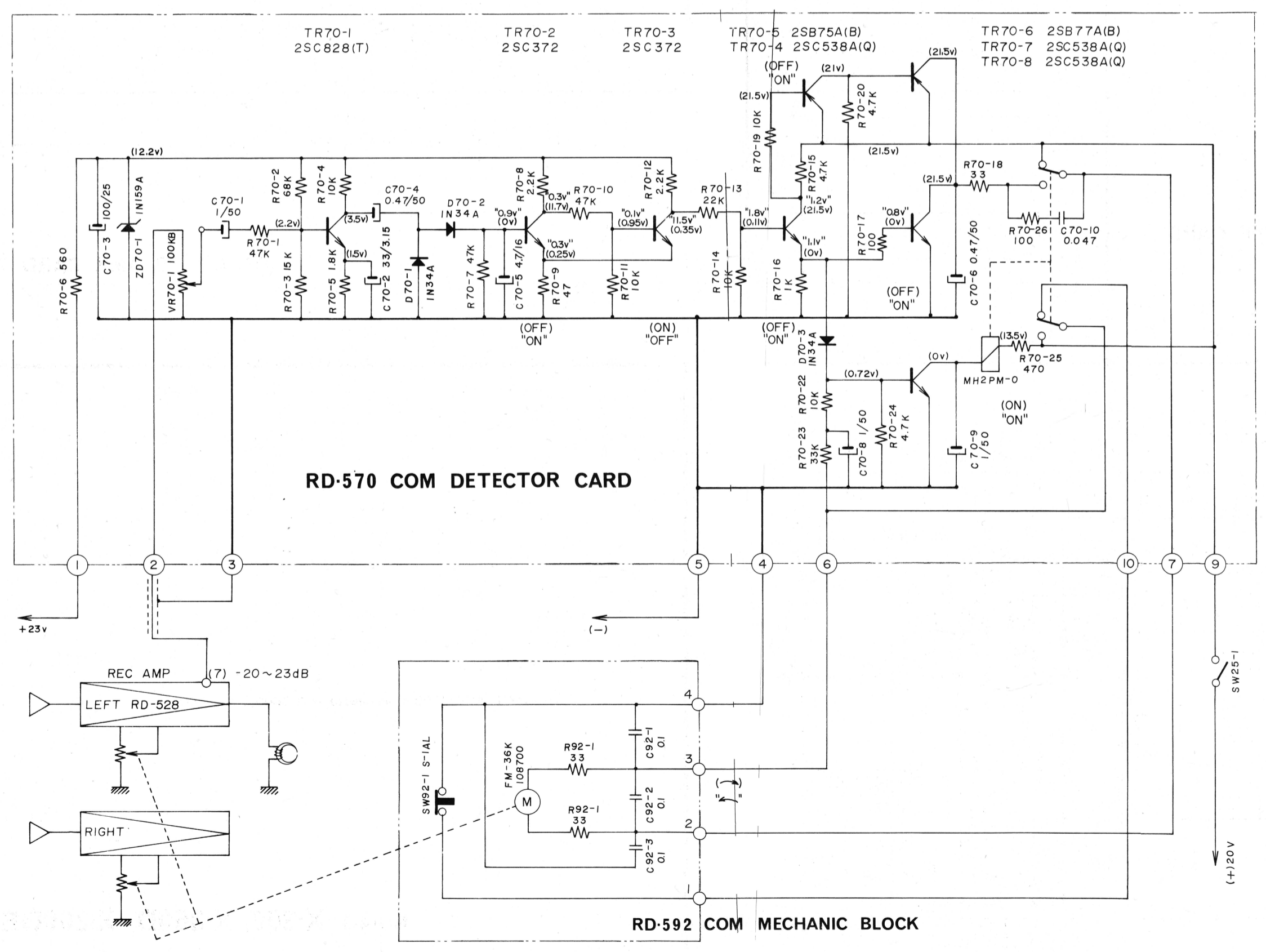
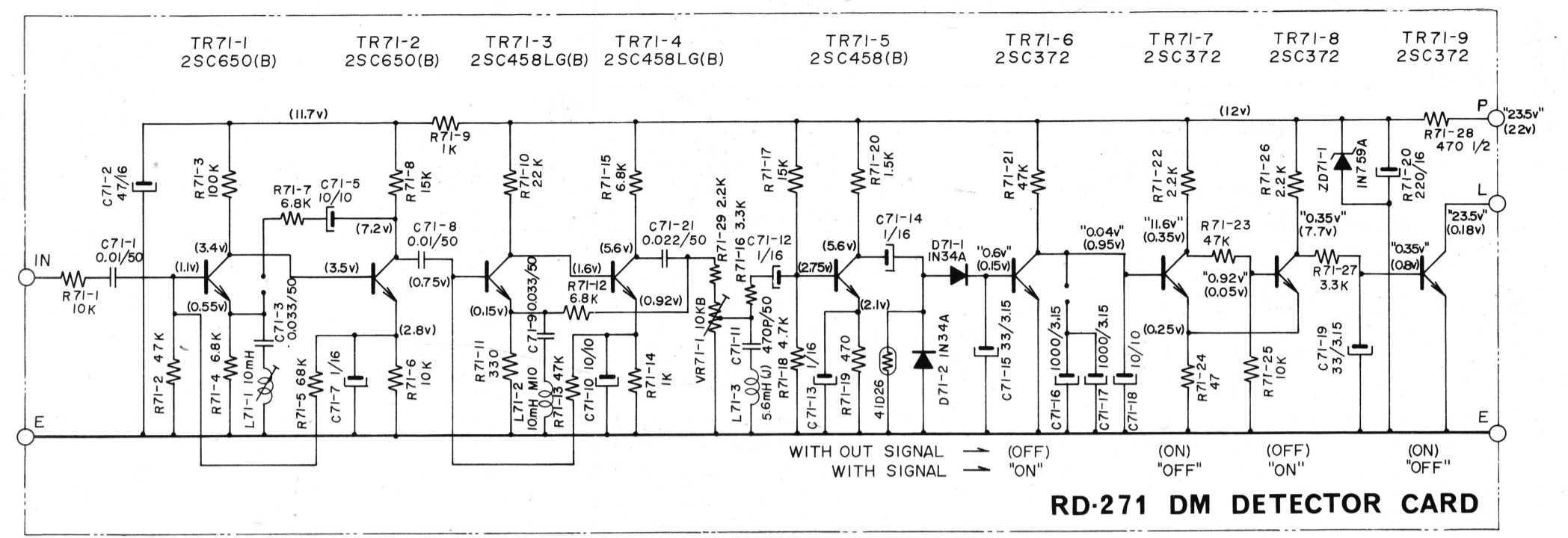
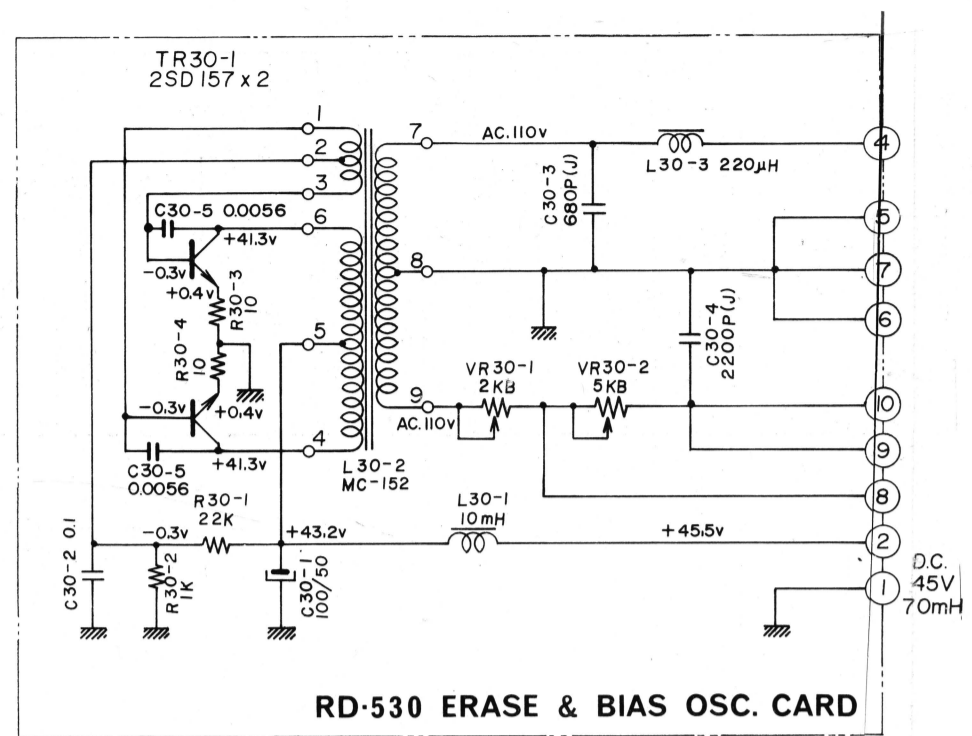

NOTE ( ) SHOWING LAMP IS "ON"  
 " " SHOWING LAMP IS "OFF"

NOTE  
 RD-570 C.O.M. DETECTOR CARD and RD-592 C.O.M. MECHANIC BLOCK is not needed in X-360DS.  
 RD-271 DM DETECTOR CARD is not needed in X-360DS.

NO.4-4 X-360, X-360D, X-360DS  
 AMP. CARD SCHEMATIC 13616124

NOTE ( ) SHOWING NON-INPUT SIGNAL CONDITION  
 SHOWING AUTOMATIC Ovu SET  
 WHILE MOTOR ROTATES (WHEN MORE THAN Ovu SIGNAL INPUT)