

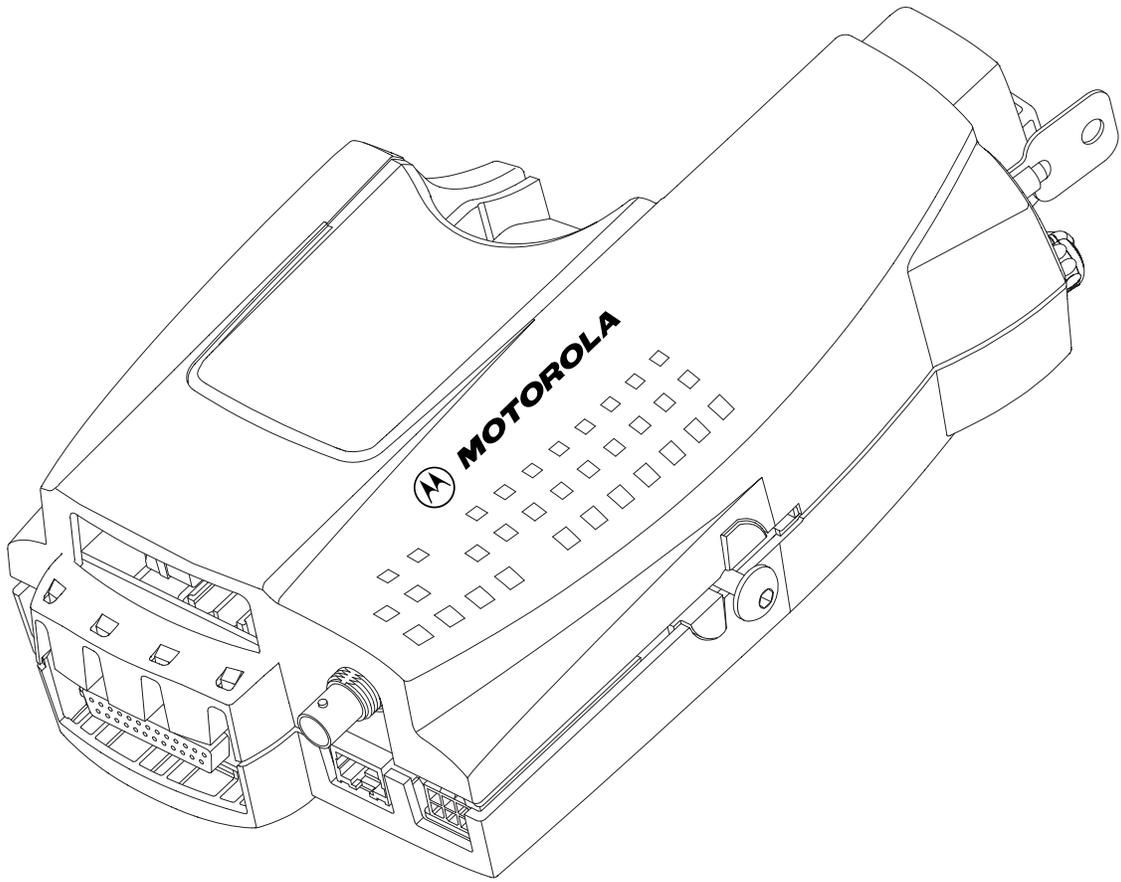

ASTRO™ XTS™ /DIMETRA™ MTP
Portable Radios
Vehicular Adapter (XTVA)
Instruction Manual



Foreword

The information contained in this manual relates to the ASTRO™ XTS™/DIMETRA™ MTP Vehicular Adapter (XTVA). This manual provides sufficient information to enable service shop personnel to troubleshoot and repair an XTVA to the component level.

Safety Information

Before operating an XTVA, please read the “Safety Information” section in the front of this manual.

Manual Revisions

Changes which occur after this manual is printed are described in “FMRs.” These FMRs provide complete replacement pages for all added, changed, and deleted items, including pertinent parts list data, schematics, and component layout diagrams.

Computer Software Copyrights

The Motorola products described in this manual may include copyrighted Motorola computer programs stored in semiconductor memories or other media. Laws in the United States and other countries preserve for Motorola certain exclusive rights for copyrighted computer programs, including, but not limited to, the exclusive right to copy or reproduce in any form the copyrighted computer program. Accordingly, any copyrighted Motorola computer programs contained in the Motorola products described in this manual may not be copied, reproduced, modified, reverse-engineered, or distributed in any manner without the express written permission of Motorola. Furthermore, the purchase of Motorola products shall not be deemed to grant either directly or by implication, estoppel, or otherwise, any license under the copyrights, patents or patent applications of Motorola, except for the normal non-exclusive license to use that arises by operation of law in the sale of a product.

Table of Contents



Foreword	inside front cover
List of Figures	ii
List of Tables	iii
List of Diagrams and Parts Lists	iii
Related Publications	iii
Specifications	iv
XTVA Model/Option Chart	v
Safety Information	vi
Safe And Efficient Operation of Motorola Two-Way Radios	vi
Exposure To Radio Frequency Energy	vi
Radio Operation and EME Exposure	vi
Operational Warnings	vii
Operational Cautions	vii
Efficient System Operation	viii
1 - Description	1
General	1
Console	2
Mobile Microphone	2
Rooftop Antenna	3
Optional External Speaker	3
Optional Radio Frequency Power Amplifier (RFPA)(XTS Only)	3
2 - Installation	5
Installation Planning	5
General	5
Console Location	6
Microphone Bracket Location	7
Visor Microphone Location	7
Antenna Location	7
Battery Connections	7
Optional External Speaker Location	7
Optional Radio Frequency Power Amplifier (RFPA) Location (XTS Only)	8
Console Installation	8
Microphone Bracket Installation	9
Visor Microphone Installation	10
Antenna Installation	10
Console Cabling	11
XTVA LED Indicators Optional Wiring	13
Optional External Speaker Installation	13
Optional Radio Frequency Power Amplifier (RFPA) Installation (XTS Only)	14
Anti-Skid Braking Precautions	15

® and Motorola are registered trademarks of Motorola, Inc.
ASTRO, DIMETRA, and XTS are trademarks of Motorola, Inc.

General	15
Installation Suggestions	15
Test Procedure	15
Installation Checkout	16
3 - Theory of Operation	17
General	17
Circuit Description	18
Charger	18
Input Line Voltage	20
5V Regulator (U7)	20
Microprocessor (U5)	20
RS232 Level Shifter (U8)	20
Optional PA/Speaker Volume Control	21
Mobile Microphone Selection and Bias	21
Charger LED Indicator Drivers	22
VRS/PAC•RT Control	22
DC Switches	22
4 - Maintenance	25
Preventive Maintenance	25
Periodic Inspections	25
Cleaning Procedures	26
Corrective Maintenance	27
Introduction	27
Test Equipment and Service Aids	27
Troubleshooting	29
Disassembly/Reassembly Procedures	29
XTVA Troubleshooting Kit Procedure	36
Assembly Instructions	37
Disassembly Instructions	40
Microprocessor Initialization	41
Safe Handling of CMOS Integrated-Circuit Devices	41
Soldering	43
Parts Replacement and Substitution	43
5 - Diagrams and Parts Lists	45
Replacement Parts Ordering	inside back cover

List of Figures

Figure 1.	Console Installation Detail	9
Figure 2.	Microphone Bracket Installation Detail	10
Figure 3.	Installing the Visor Microphone	10
Figure 4.	Console Connections	11
Figure 5.	Console Cabling	12
Figure 6.	External Speaker Installation Detail	14
Figure 7.	Console Functional Block Diagram	18
Figure 8.	Disconnecting the Flex Cable	31
Figure 9.	Removing the Kicker	31
Figure 10.	Removing the Latch Assembly	32
Figure 11.	Replacing the PCB Assembly	33
Figure 12.	Reassembling the Latch Assembly	34
Figure 13.	Installing the Kicker	34
Figure 14.	Reassembling the Universal Subassembly	36
Figure 15.	Flex Against the Chassis	37
Figure 16.	Connecting the Flex Extender	38
Figure 17.	Placing the Troubleshooting Rear Housing on the Console Front Housing	39
Figure 18.	Securing the Flex Circuit Ribbon	40
Figure 19.	DC Switch Section Logic Diagram	45

List of Tables

Table 1.	Rated Power and Distance	vi
Table 2.	Recommended Antennas	3
Table 3.	XTVA Functions	23
Table 4.	Recommended Test Equipment	28
Table 5.	Charger Section Voltage Measurements.	45
Table 6.	LED Circuitry Section Voltage Measurements	45
Table 7.	DC Switch Section Voltage Measurements	45

List of Diagrams and Parts Lists

Troubleshooting Flow Chart	46
Revision Level A Printed Circuit Board Electrical Parts List	47
Console Revision Level A Printed Circuit Board Component Location Diagram	48
Console Revision Level A Printed Circuit Board Schematic Diagram	49
Revision Level B Printed Circuit Board Electrical Parts List	51
Console Revision Level B Printed Circuit Board Component Location Diagram	52
Console Revision Level B Printed Circuit Board Schematic Diagram	53
Console Exploded View and Exploded View Parts List	54

Related Publications

DIMETRA MTP 200/300 User Guide	68P02400U04
DIMETRA MTP 200/300 Quick Reference Guide	68P02400U55
ASTRO XTS 3000 Model I User Guide	68P81083C70
ASTRO XTS 3000 Model III User Guide	68P81083C75
ASTRO XTS 3000 Model II User Guide.	68P81083C94
ASTRO XTVA User Guide	68P81088C76
ASTRO XTVA Installation Manual	68P81088C77
ASTRO XTVA Handheld Control Head User Guide	68P81088C79
ASTRO XTS 3500 Model I User Guide	68P81089C77
ASTRO XTS 3500 Model II User Guide.	68P81089C78
ASTRO XTS 3500 Model III User Guide	68P81089C79
Connecting Accessories to XTVA Installation Manual	68P81092C83

Specifications

UNIT CAPACITY:	One ASTRO Digital XTS 3000 or XTS 3500 or DIMETRA MTP Portable Radio	
DIMENSIONS (L x H x W):	8.8" x 5.7" x 2.7" (223 mm x 143mm x 67mm)	
WEIGHT: (without portable radio)	2.2 lbs. (1000 g)	
NOMINAL INPUT VOLTAGE:	13.8 Vdc (negative ground)	
CURRENT DRAIN: Ignition Off, No Radio: Ignition On, No Radio:	10 mA Maximum 50 mA Maximum	
	CHARGED BATTERY	DISCHARGED BATTERY
Standby:	0.4A	0.8A
Receive with 6W Audio:	1.2A	1.6A
Transmit:	1.8A	1.8A
CHARGE TIME:	Three hours maximum (Medium-, High-, and Ultra-High-Capacity Batteries)	
ANTENNA INPUT IMPEDANCE:	50 Ohms	
AUDIO OUTPUT: Basic XTVA: XTVA with Optional PA/Speaker:	500 mW (at less than 5% distortion) (Note: Portable speaker output)	
	6 W (at less than 10% distortion) (Note: External speaker output)	

XTVA Model/Option Chart

MODEL NUMBER				DESCRIPTION		
N1799A				XTVA, Closed-Face, Mini-UHF		
N2001A				XTVA, Open-Face, Mini-UHF		
N2002A				XTVA, Open-Face, BNC		
N2003A				XTVA, Closed-Face, BNC		
				KIT NUMBER	DESCRIPTION	
S				NTN8561_	XTVA, Closed-Face, Mini-UHF	
	S			NTN8560_	XTVA, Open-Face, Mini-UHF	
		S		NTN1606_	XTVA, Open-Face, BNC	
			S	NTN1607_	XTVA, Closed-Face, BNC	
				OPTION NUMBER	KIT NUMBER(S) PROVIDED	DESCRIPTION
•	•	•	•	H34AB	NLD8905A	Power Amplifier, RF, VHF
•	•	•	•	**	**	Power Amplifier, RF, UHF Range 1
•	•	•	•	**	**	Power Amplifier, RF, UHF Range 2
•	•	•	•	Q150AB	NLF4568A	Power Amplifier, RF, 800MHz
•	•	•	•	Q147AB	HKN6455A	PA/Speaker, 6-Watt
•	•	•	•		HSN1000B	Cable, 6-Watt PA/Speaker
•	•	•	•	Q229AB	PLN7737A	Control Head, Hand-Held (HHCH)
•	•	•	•	Q760AA	HMN4069B	Microphone, Next Generation Mobile (NGMM)
•	•	•	•	Q328AA	HMN4072_	Microphone, Classic Palm
•	•	•	•	H858AB	NTN8940A	Kit, XTVA Trunnion Mount
•	•	•	•		NTN8941A	Kit, XTVA Data Cable
•	•	•	•		NTN8982A	Kit, XTVA Troubleshooting
•	•	•	•		NKN6516A	Cable, RFPA
•	•	•	•		NTN9027A	Cable, XTVA Programming
				DIMETRA ACCESSORIES	KIT NUMBER	DESCRIPTION
		•			FLN8834A	Switch, External Push-to-Talk (PTT)
		•			FMN1616A	Microphone, Hands-Free (Visor Mic)
		•			GLN7280A	Handswitch, Emergency
		•			GLN7282A	Buzzer
		•			HLN9328A	Relay, Emergency Alarm
		•			HLN9330A	Footswitch, Emergency
		•			HSN1006A	PA Speaker, 6-Watt
		•			NTN8943A	Kit, XTVA Accessory Connector

S = Standard

• = Compatible Option/Kit

** = Not Available

Safety Information

Safe And Efficient Operation of Motorola Two-Way Radios

Exposure To Radio Frequency Energy

National and International Standards and Guidelines

Your Motorola Two-Way Radio, which generates and radiates radio frequency (RF) electromagnetic energy (EME), is designed to comply with the following National and International Standards and Guidelines regarding exposure of human beings to radio frequency electromagnetic energy:

- Federal Communications Commission Report and Order No. FCC 96-326 (August 1996)
- American National Standards Institute (C95.1 - 1992)
- National Council on Radiation Protection and Measurements (NCRP - 1986)
- International Commission on Non-Ionizing Radiation Protection (ICNRP - 1986)
- European Committee for Electrotechnical Standardisation (CENELEC):
 - ENV. 50166-1 Human Exposure to Electromagnetic Fields Low Frequency (0Hz to 10kHz) 1995 E
 - ENV. 50166-2 Human Exposure to Electromagnetic Fields High Frequency (10kHz to 300GHz) 1995 E
 - Proceedings of SC211/8 1996 Safety Considerations for Human Exposure to E.M.F.s from Mobile Telecommunications Equipment (M.T.E.) in the Frequency Range 30MHz - 6 GHz (E.M.F. - Electromagnetic Fields)

Radio Operation and EME Exposure

To assure optimal radio performance and that human exposure to radio frequency (RF) electromagnetic energy is within the guidelines set forth in the above standards, transmit with any vehicular adapter with an RFPA *only* when people inside and outside the vehicle are no closer than the distance shown in Table 1.

Note: Table 1 applies only to an XTVA with an RFPA. The power output of XTS radios ranges from 1 to 6 watts; MTP radios have a 1-watt output.

Table 1 Rated Power and Distance

Rated Power of Vehicle-installed Two-way Radio with RFPA	Minimum Distance from Transmitting Antenna
7 to 15 Watts	1 Foot (30.5 Centimeters)
16 to 50 Watts	2 Feet (61.0 Centimeters)

Electromagnetic Interference/Compatibility

Note: Nearly every electronic device is susceptible to electromagnetic interference (EMI) if inadequately shielded, designed, or otherwise configured for electromagnetic compatibility.



Operational Warnings

WARNING

- Vehicles With an Air Bag

Do not place a portable radio or install radio communications equipment in the area over an air bag or in the air bag deployment area. Air bags inflate with great force. If a portable radio is placed in the air bag deployment area and the air bag inflates, the radio may be propelled with great force and cause serious injury to occupants of the vehicle.

- Installation of vehicle communication equipment should be performed by a professional installer/technician qualified in the requirements for such installations. An airbag's size, shape, and deployment area can vary by vehicle make, model, and front compartment configuration (e.g., bench seat vs. bucket seats).
 - Contact the vehicle manufacturer's corporate headquarters, if necessary, for specific airbag information for the vehicle make, model, and front compartment configuration involved in your communication equipment installation.
- Potentially Explosive Atmospheres

Turn your radio *OFF* and eject it from the XTVA in any area with a potentially explosive atmosphere. It is rare, but your XTVA or its accessories could generate sparks. Sparks in such areas could cause an explosion or fire, resulting in bodily injury or even death.

Note: The areas with potentially explosive atmospheres referred to above include fueling areas such as: below decks on boats; fuel or chemical transfer or storage facilities; areas where the air contains chemicals or particles, such as grain, dust, or metal powders; and any other area where you would normally be advised to turn off a vehicle engine. Areas with potentially explosive atmospheres are often, but not always, posted.

DO NOT transport or store flammable gas, liquid, or explosives in the compartment of your vehicle that contains your XTVA or accessories.

Vehicles powered by liquefied petroleum gas (such as propane or butane) must comply with the National Fire Protection standard (NFPA-58). For a copy of this standard, contact the National Fire Protection Association, One Batterymarch Park, Quincy, MA, Attn: Publications Sales Division.

- Blasting Caps and Blasting Areas

To avoid possible interference with blasting operations, turn your radio off and eject it from the XTVA when you are near electrical blasting caps, in a blasting area, or in areas posted "Turn off two-way radio." Obey all signs and instructions.

Operational Cautions



Caution

- Antenna Information

Antennas should be installed according to installation instructions supplied with the equipment. To ensure compliance with the standards listed above, use only recommended antenna types, such as a 1/4-wave vertical whip or vertical gain antenna.

- Electronic Devices

Most modern electronic equipment—for example, equipment in ambulances, navigation equipment, etc.—is shielded from RF energy; however, RF energy from your XTVA may affect some electronic equipment.

Consult your physician or the manufacturer of any personal medical devices (such as pacemakers, hearing aids, etc.) to determine if they are adequately shielded from external RF energy. The operation of inadequately shielded medical devices may be adversely affected when operated near an XTVA.

Turn the radio *OFF* in health-care facilities when any regulations posted in the areas instruct you to do so. Always request permission before using the radio or XTVA near medical equipment.

RF energy may affect electronics systems in some motor vehicles. Check with your vehicle manufacturer's representative to be sure that the XTVA will not affect your vehicle's electronic system.

Efficient System Operation

- *DO NOT* operate your XTVA unless all RF connectors are properly terminated.
- All equipment must be properly grounded according to Motorola installation instructions for safe operation.
- All equipment should be serviced only by an authorized technician.

Notations Used in This Manual

Throughout the text in this publication, you will notice the use of warnings, cautions, and notes. These notations are used to emphasize that safety hazards exist, and care must be taken and observed.

Note: An operational procedure, practice, or condition, etc., which is essential to emphasize.



Caution

CAUTION indicates a potentially hazardous situation which, if not avoided, may result in equipment damage.



WARNING

WARNING indicates a potentially hazardous situation which, if not avoided, could result in death or injury.



DANGER indicates an imminently hazardous situation which, if not avoided, will result in death or injury.

You will also find in this publication the use of the asterisk symbol (*) to indicate a negative or NOT logic true signal.

Description



General

The Motorola ASTRO XTS/DIMETRA MTP Vehicular Adapter (XTVA) is an accessory that adapts XTS and MTP series radios to operate in a vehicular (mobile) environment, and allows in-vehicle battery charging. The XTVA is designed to operate only with the combination of an XTS/MTP series radio and one of the following batteries:

- NTN8294_ Ultra-High Capacity NiCd,
- NTN8295_ Ultra-High Capacity NiCd,
- NTN8297_ Ultra-High Capacity NiCd,
- NTN8299_ Ultra-High-Capacity NiMH, or
- NTN8923_ Ultra-High-Capacity NiMH (for optimal NiMH performance).

XTVA consoles with revision levels of “B” or higher can also charge compatible lithium-ion batteries. The use of batteries not made by Motorola is not recommended.

The vehicular adapter consists of a console, a hand-held mobile microphone or hand-held control head (HHCH), a rooftop antenna (not supplied), mounting hardware, and supply cable. Optional items, such as an amplified speaker or RF power amplifier may also be included.

When the radio is inserted into the console, the resulting combination acts similar to a mobile radio, with the following automatic functions:

- The vehicular adapter connects the vehicle’s external antenna to the radio, and the radio’s portable antenna becomes electrically disconnected. Proper operation of this function requires the use of an RF adapter (Part No. NTN8327_) on the portable radio. Use of the XTVA without the RF adapter may result in damage to the XTVA.
- The vehicular adapter’s mobile microphone is connected to the radio, and the radio’s internal microphone is not operational. Normal portable microphone operation resumes upon ejection.
- The console’s charging circuits are connected to the radio’s battery to charge it.
- The XTVA with the power amplified speaker (PA/speaker) option will automatically mute the radio’s internal speaker and transfer received messages to the PA/speaker. The audio level of the PA/speaker is set by the console volume control or (XTS only) HHCH and is independent from the radio volume control setting. The portable audio level will resume at the level set by the portable’s volume knob when the radio is removed from the console.

- (XTS Only) The radio's display and keypad functions are controlled by the HHCH, if installed. Changes made to the mode and zone control settings will remain in effect on the radio when it is ejected from the console. Control is returned to the radio's knobs and programmable buttons when the radio is ejected.

Console

The NTN1606_, NTN1607_, NTN8560_, or NTN8561_ Console is the vehicular adapter's central unit. The console comprises an internal radio battery charger, a radio latching mechanism with lock, and circuitry for interconnecting the radio, microphone, and external antenna.

When the radio is loaded into the console, the combined radio/console operates similar to a mobile two-way radio. The radio must have a battery attached when it is inserted into the console; with the vehicle switched on, this battery will be automatically charged when the radio is inserted. *Do not insert a battery without a radio.* A key lock is provided on the console to prevent theft when the vehicle is left unattended. Appropriate mounting hardware is available as an option to allow installation of the XTVA in various locations in the vehicle.

The XTVA has no **On/Off** switch. In order to charge the radio's battery, the vehicle's ignition switch must be turned on. However, the receive and transmit audio functions of the XTVA are always operational regardless of the ignition switch condition. These circuits activate whenever the XTVA detects that a radio has been loaded and turned on.

The operation and controls of the ASTRO XTS Vehicular Adapter maintain the same functionality as those of an ASTRO Digital XTS or DIMETRA MTP series radio.



Caution

In some installations, the ignition switch is bypassed so that the XTVA charges the radio battery with the ignition switch turned off. If this describes your installation, be careful not to discharge the vehicle battery by allowing the XTVA to operate for extended periods of time with the vehicle ignition switch turned off.

Mobile Microphone

Four different types of mobile microphones are available for the XTVA: the HMN4072_ Palm Microphone, the HMN4069_ Next Generation Mobile Microphone, the FMN1616_ Hands-Free Visor Microphone, and (XTS only) the full-featured PLN7737_ Hand-Held Control Head (HHCH) Microphone.

HMN4069_ and HMN4072_ are palm-type, weatherproof, cartridge microphones, with transistorized preamplifiers as an integral part of the cartridge. Each microphone is equipped with a push-to-talk (PTT) switch on the side, and has a coil cord cable with an 8-pin connector that plugs into the microphone jack on the console.

The FMN1616_ Hands-Free Visor Microphone is an EMC-approved DIMETRA accessory that clips to the vehicle's visor and is activated by an external PTT switch (FLN8834_).

The PLN7737_ Hand-Held Control Head Microphone (XTS only) has a keypad and a display that duplicates the functions of the radio's keypad and display.

Rooftop Antenna

To enable the XTVA to function as a mobile radio, an external vehicular antenna or an RF amplifier and antenna must be connected to the console. Refer to the “Installation” section of this manual for technical details. Table 2 lists, by kit number, recommended antennas, and gives a brief description of each antenna.

Table 2 Recommended Antennas

ANTENNA KIT NUMBER	CONNECTOR TYPE	DESCRIPTION
FAE5521_	BNC	1/4-wave, 380 - 400MHz for MTP
FAE6003_	BNC	1/4-wave, 410 - 430MHz for MTP
TAD6111_	Mini-UHF	1/4-wave, 136 - 144MHz
TAD6112_	Mini-UHF	1/4-wave, 144 - 152MHz
TAD6113_	Mini-UHF	1/4-wave, 152 - 162MHz
TAD6114_	Mini-UHF	1/4-wave, 162 - 174MHz
RAE4012_	Mini-UHF	5 dB gain, 406 - 420MHz
RAE4014_	Mini-UHF	5 dB gain, 445 - 470MHz
RAE4015_	Mini-UHF	5 dB gain, 470 - 494MHz
RAE4016_	Mini-UHF	5 dB gain, 494 - 512MHz
RAF4001_	Mini-UHF	806 - 866MHz
RRA4936_	Mini-UHF	890 - 960MHz

Note: To connect an antenna with a mini-UHF connector to an XTVA with a BNC connector, use connector adapter Motorola Part No. 5880367B28.

Optional External Speaker

The optional HSN1000_ or HSN1006_ 6-Watt Speaker provides 6 watts of audio output power for use in high noise level environments. The audio level of the speaker is adjustable using the volume control on the console or the HHCH. The portable radio’s volume setting can remain set for best audio loudness when used as a portable. There is no need to readjust the radio volume setting each time the radio inserted into, or removed from, the XTVA console.

Optional Radio Frequency Power Amplifier (RFPA)(XTS Only)

The optional RF Power Amplifier amplifies an RF Signal so that the user can achieve greater range using the VA than with the portable radio alone. The RFPA operates within a specified frequency range, and must be matched to the frequency range of the portable radio. There are no tuning components in the amplifier. The amplifier is part of a half duplex system. In transmit mode it amplifies the output signal from the radio to the system’s antenna. In receive mode it passes the signal from the antenna to the radio.

Installation

2

This section describes the complete installation procedure for the ASTRO XTS/DIMETRA MTP Vehicular Adapter (XTVA) used with XTS/MTP series radios. Installation includes planning, mounting, and checkout. The XTVA allows an XTS/MTP portable radio to operate similar to a mobile radio while the radio is in the adapter. Read these instructions before installing your XTVA.

Installation Planning

General

The XTVA consists of the following:

- console
- hand-held microphone, or (XTS only) hand-held control head (optional)
- supply cable
- mounting hardware
- external speaker and cable (optional)
- (XTS only) radio frequency power amplifier (RFPA) (optional)
- roof-top antenna (not supplied)
- other optional accessories (installation not covered in this manual)

Note: Some optional accessories require the use of an XTVA Accessory Adapter Kit (NTN8943_) or a Data Cable Kit (NTN8941_).

Before starting the installation, plan the location of the console, microphone, RFPA (optional), and external speaker (optional). Identify the routing path for all cables. Verify that the cable lengths are sufficient.

Also, check the mounting penetrations required. On most vehicles, it is necessary to penetrate the firewall to reach the battery. Check the opposite side of the firewall for cable clearance before drilling holes, and protect the cable where it passes through the firewall by using the supplied grommets or other similar protective measures. Survey the firewall for existing holes occupied by vehicle wire harnesses. Often there is an opportunity to route other cables using the same path. Because of the wide variations in vehicle design, these instructions may be modified to suit each particular installation.

A properly installed XTVA will minimize service calls and equipment downtime. Consider the following guidelines when planning the installation:

- **DO** insert provided S-hooks on cables into restraining holes for strain relief.

- **DO** use heat-shrink tubing on all splices.
- **DO** ensure that unit cables are not placed under stress, are not exposed to weather, and are not subjected to damage due to engine heat.
- **DO** retain in-line cable fuses when trimming cables to fit. Locate in-line fuses as close as practical to the supply voltage connection.
- **DON'T** attach the units to any part of the vehicle that is not rigid or is subject to excessive vibration.
- **DON'T** install units in areas where rain or snow can easily get into them, such as next to a vehicle window which may be left open.
- **DON'T** dress cables over sharp edges that could cause wear or tearing of cable insulation.
- **DON'T** install the units in locations where they might interfere with the vehicle's operator or operating controls.
- **DON'T** install the units where they will be difficult for the operator to reach.
- **DON'T** install the units where they will interfere with vehicle safety air bag deployment.



WARNING

For vehicles with electronic anti-skid braking systems, refer to the "Anti-Skid Braking Precautions" section of these instructions.



Caution

Before drilling, check the opposite sides of all mounting surfaces for obstructions, such as vehicle wiring and fluid lines.

Console Location

The optional trunnion ("U") bracket can be used to mount the XTVA console either off the vehicle floor or under the vehicle dash. The console should first be attached to the bracket, and then the console-bracket combination can be evaluated for the proper mounting location. The console should be mounted to provide:

- 12 inches (30.48cm) of clearance in front of the console for inserting and removing the radio,
- clearance on either side of the console is necessary for inserting and tightening screws to secure the console to the bracket,
- a 6-inch (15.24cm) clearance in back of the console for connection of power, microphone, antenna, and speaker cables, and
- a 1-inch (2.54cm) clearance above the vents on the top of the console.

Consider accessibility to the controls by the operator. Other considerations in deciding on the best mounting location are:

- the hang-up location for the microphone,
- the microphone's coil cord length (extended) during operation,
- the operability of the radio's controls while it is in the console, and
- a substantial structure for accepting mounting screws.
- the speaker mounting location and cable length.

When possible, mount the console on the floor near the center of the vehicle within easy reach of the operator.

Microphone Bracket Location

When possible, mount the microphone bracket on the dash near the operator side of the console. The location should be within easy reach of the operator, and it should be convenient to remove and hang-up the microphone in its mounting bracket without interfering with any of the vehicle controls.



Caution

Do not attach the microphone bracket to the console housing.

Visor Microphone Location

The hands-free visor microphone is designed to clip onto the vehicle's sun visor.

Antenna Location

Complete antenna installation instructions are supplied with each antenna kit. Refer to those instructions for information pertaining to the antenna.

Battery Connections

Determine the best cable route from the rear of the console to the vehicle battery through the engine compartment firewall. The best route should include the shortest path to the battery terminals, yet provide the cable with protection from engine heat. Cut off any excess cable. Be sure to use the supplied grommet or similar protective measure wherever a cable must pass through a hole in a metal panel, such as a firewall. Route the power cables in a way that protects them from being pinched, chafed, or crushed. Cable fuses must be retained and located as close to the battery as practical to protect against cable or equipment shorts. Secure the cable along its length through the engine compartment to prevent displacement during vehicle operation and service.

Optional External Speaker Location

Select a location for the speaker that will be neither dangerous to the operator nor damaging to the speaker. A trunnion bracket is provided for mounting the speaker. The speaker is normally hung under the dash near the right side of the console; however, the trunnion bracket permits mounting the speaker against a wall or other vertical surface, if desired.

A location close to the operator, such as a on a door pillar, will minimize XTVA volume adjustments that might otherwise be needed when ambient noise conditions worsen (such as when a siren is used). This location is also favorable during low-volume security patrol, since message traffic does not pre-announce the XTVA operator.

The speaker can be removed from its mounting bracket by the operator and hung from a window, allowing it to be heard outside the vehicle. For installations where this external operation is desirable, adequate service length of speaker cable must be available. Also, provide an area, on the mounting bracket or some other location, for wrapping this service length.

Note: If using the optional hands-free visor microphone, mount the speaker at least 5 feet (1.74m) from, and not in line with, the microphone. Mounting the speaker on the dashboard or rear package tray is not recommended. For optimum radio performance, install the speaker under the dashboard.

Optional Radio Frequency Power Amplifier (RFPA) Location (XTS Only)

When possible, mount the RFPA as close as practical to the external antenna, in a location that does not restrict air flow through the cooling fins. The RFPA is typically mounted in the vehicle's trunk. Complete mounting instructions are supplied with each RFPA kit. Refer to those instructions for information pertaining to the RFPA. Refer to the console's "Battery Connections" section above for RFPA power cable routing recommendations. A 17' (6.02m) coaxial cable with a mini-UHF connector on one end is also supplied with the RFPA. This cable must be routed from the console to the RFPA. The mini-UHF connector attaches to the PA. The cable should be cut to the appropriate length and the supplied mini-UHF or BNC connector attached.

Console Installation

Referring to Figure 1, install the console using the following procedure, or modify the procedure as necessary to conform to the vehicle type.

Using the optional trunnion ("U") bracket as a template, drill the mounting holes and mount the bracket with the hardware supplied (see Figure 1).

Note: Failure to use the four outermost holes on the trunnion bracket, or mounting the bracket on a non-flat surface (such as a transmission hump) could degrade vibration performance. Additionally, the VA trunnion bracket should be mounted on a metal surface.

Note: When the bracket is mounted in carpet, the self-tapping screws tend to bind up. To overcome this, tap the screw through the carpet, back out the screw, then tighten the screw down.

1. Remove the Allen-head screws from the side of the console.

Important Note: To avoid permanent damage to the unit, if mounting the console in a customer-provided bracket, ensure that the Allen-head screw shaft protrudes into the console's chassis no more than 17/32" (1.35cm) and no less than 1/2" (1.27cm).

2. Ensure that the plastic guides of the trunnion are aligned (horizontally) with the corresponding grooves of the console (see Figure 1). Slide the XTVA console into the plastic guides until it reaches the mechanical stop. Verify that the holes in the trunnion bracket are aligned with the holes on the XTVA chassis.
3. Insert the Allen-head screws provided through the trunnion bracket and screw them into the console. Since the console may have to be removed later to connect the cables, do not tighten the screws at this time.

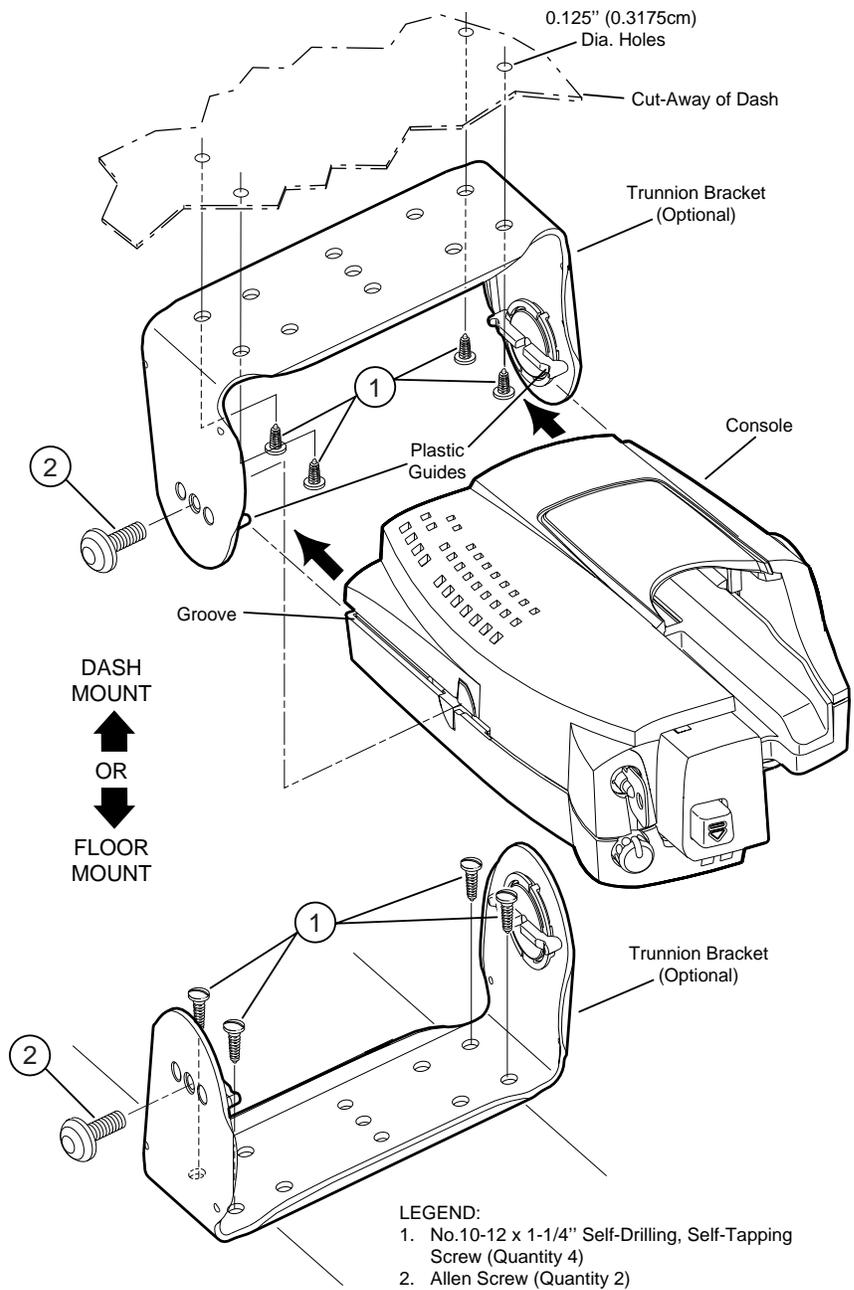

Figure 1 Console Installation Detail

Microphone Bracket Installation

Note: The microphone bracket should be mounted on a substantial structure. Otherwise, repeated insertion and removal of the microphone could loosen it.

Referring to Figure 2, use the microphone bracket as a template and drill two 1/8-inch (0.32cm) holes. Attach the microphone bracket to the mounting surface with the two self-tapping screws provided. Be sure to leave sufficient room above the bracket for inserting and removing the microphone.

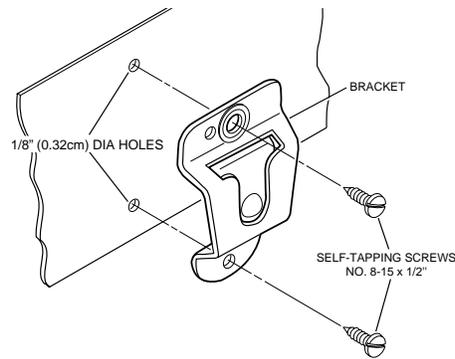

Figure 2 Microphone Bracket Installation Detail

Visor Microphone Installation

1. Referring to Figure 3, clip the microphone to the vehicle's visor.
2. To avoid visual or physical obstruction, route the microphone cable down inside the door molding and beneath the seat. Allow sufficient slack in the connector end of the cable to reach the XTVA.

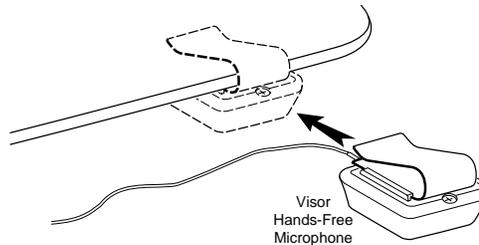

Figure 3 Installing the Visor Microphone

For information on connecting the visor microphone to the XTVA, see the XTVA Accessory Connector Installation Manual, Motorola publication 68P81092C83 (included with this manual).

Antenna Installation

Install the antenna and antenna cable as outlined in the installation instructions supplied with the antenna. Pertinent information on frequency matching and mounting details are also provided with each antenna.

Note: The RF connector (J3) on XTVA console models N1799_ and N2001_ is a mini-UHF jack, and must be mated with either an antenna mini-UHF plug (P3) or an appropriate adapter (Motorola part numbers: 5880367B21 [mini-UHF-to-N]; 5880367B22 [mini-UHF-to-UHF]; or 5880367B24 [mini-UHF-to-TNC]).

Note: For XTVA console models N2000_, N2002_ and N2003_, the RF connector (J3) is a BNC-type connector that must be mated with either an antenna BNC plug (P3) or a mini-UHF female-type adapter (Motorola part number 5880367B28).

Console Cabling

Refer to Figures 4 and 5 before routing or connecting any console cable. The console should be cabled using the following procedure:



Caution

- This product is designed for a 12-volt, negative-ground system.
- Remove the 5-amp fuses from the power cable (red and yellow wires) before proceeding.

Note: Due to space restrictions, it may be necessary to remove the console before making connections to the connectors at the back of the console. If this is the case, make all connections and remount the console before replacing the 5-amp fuses.

Note: For applications where the mounting structure of the console is hinged (for example, swing cab), make sure to provide sufficient service length for cables.



Caution

The Revision A console has a short extension cable (P/N 3085361C01) connected to the power supply connector, J2. **Do not** attempt to tamper with or remove this extension.

1. After setting the 2-foot (61cm) section of the main power cable's red lead aside for later use, route the main power cable through the firewall and into the vehicle battery area. Use an existing opening or, if necessary, drill a 3/8-inch (0.953cm) hole through the firewall. Insert the grommet provided with the mounting kit into the hole to prevent damage to the power cable.

Important Note: Failure to mount the red lead of the power cable kit directly to the battery may result in severe alternator whine interference. If severe alternator whine interference is present when the power cable is properly installed, a power line filter kit, TLN5277_, can be purchased to reduce the interference.

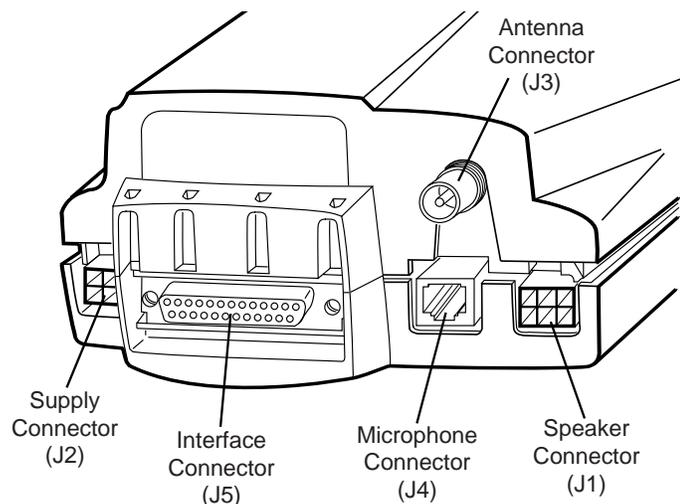

Figure 4 Console Connections

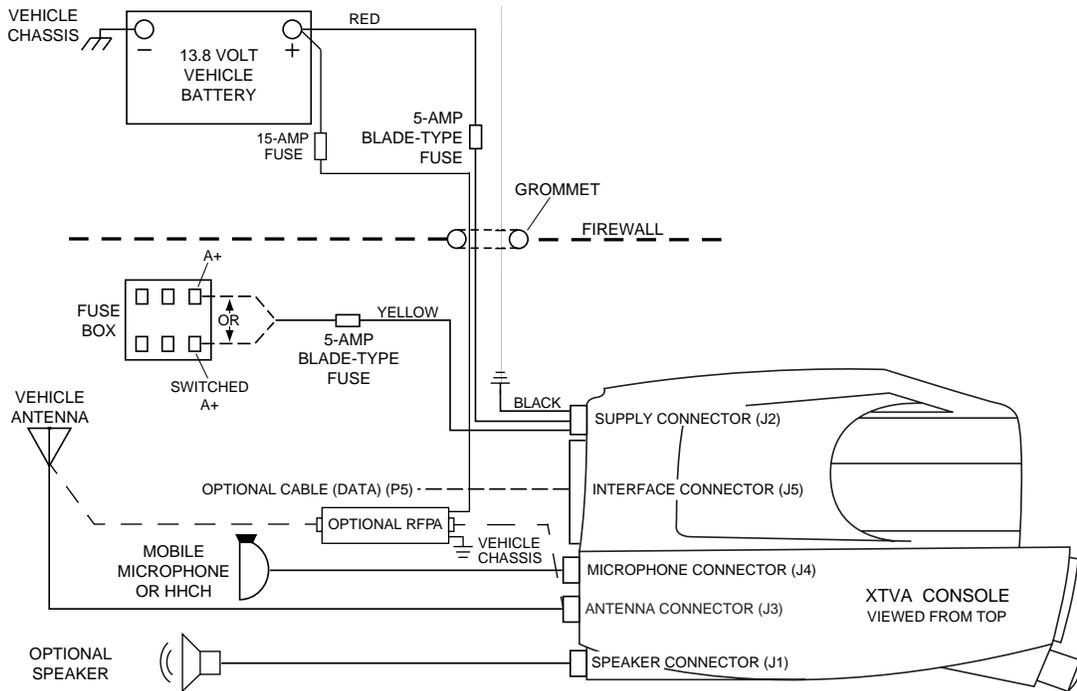

Figure 5 Console Cabling

2. Connect the supply cable wires as shown in the table, below.

Wire Color	Connect To
Red	Vehicle battery (+)
Black	Vehicle Chassis (Gnd)
Yellow	Fuse box (see below for details)

The yellow wire controls whether or not the XTVA radio battery charger will be “live” at all times. Consider the functionality and vehicle battery drain current below during installation.

Standard Wiring to Vehicle Switched A+ — Charging OFF with Vehicle OFF

For installations where the radio may be left in the XTVA with the vehicle’s ignition switched OFF and minimal vehicle battery drain current is important, the *standard wiring connection* of the yellow wire to vehicle switched A+ will disable charging.

Optional Wiring to Vehicle A+ — Charging ON with Vehicle OFF

When the radio is left in the XTVA for charging with the vehicle’s ignition switched OFF, the *optional wiring connection* of the yellow wire to always-live vehicle (A+) will keep the charger ON. When the operator takes the radio from the XTVA, low vehicle battery drain current will occur. See (*) below.

	Standard Wiring		Optional Wiring
	Veh = ON	Veh = OFF	Vehicle = ON or OFF
Battery Charging	Yes	No	Yes
Vehicle Battery Discharge:			
Radio OUT	<10mA	<10mA	<10mA (*)
Radio IN but OFF	30-600mA	<10mA	30-600mA
Radio IN and ON	180-750mA	130mA	180-750mA

3. Cut the long red lead to the desired length (as long as possible so that the in-line fuse is located as close as practical to the vehicle battery). Then, after running the lead through the firewall, connect (crimp and solder) it to the plug on the 2-foot (61cm) red lead section that was set aside in step 1. Make sure that the plug and jack in the lead are connected securely together., and that they are properly insulated with the supplied heat-shrink tubing.

4. Cut the yellow lead to the desired length, then connect it to the supply side of the fuse box, according to the above table. *It is important not to connect the yellow wire to the red lead.*
5. Cut the black lead to the desired length, then connect it to the vehicle chassis.



Caution

It is NOT good practice to connect the supply cable black lead directly to the negative (-) battery terminal; the XTVA could be damaged if there were a malfunction in the vehicle's electrical system.

6. Dress the cable so that it does not obstruct any vehicle controls nor touch any hot or moving parts of the engine.
7. Connect power cable plug P2 to console jack J2.
8. If the optional external speaker is being installed, connect speaker cable plug P1 to console jack J1. Attach the strain-relief S-hook to the console; crimp the S-hook with a pair of pliers.
9. Connect external antenna cable plug P3 to console jack J3. If your model has a mini-UHF type connector, use Mini-UHF Connector Tool (P/N REX4584_) to tighten the connector.
10. Connect microphone cable plug P4 to console jack J4. Attach the strain-relief S-hook to the console; crimp the S-hook with a pair of pliers.
—or—
(XTS only) If you are using the NTN9013_ Hand-Held Control Head, connect the control head cable plug to console jack J4. Attach the strain-relief S-hook to the console; crimp the S-hook with a pair of pliers.
11. Make certain that no radio is installed in the console, then replace the two cable wire 5-amp fuses.

XTVA LED Indicators Optional Wiring

The XTVA's LED indicators can be dimmed or disabled for night use or surveillance operations by using the optional wiring connections below:

- Dimming—Use wire with a Molex crimp terminal (P/N 39-00-0078) to connect the empty pin (pin 4) on the power cable to the vehicle's headlight switch.
- Disable—Jumper pins 10 and 13 on a standard male DB25-type connector or Motorola P/N NTN8943_, XTVA Accessory Adapter Kit and plug into console jack J5.

Optional External Speaker Installation

The optional external speaker includes a trunnion bracket that permits the speaker to be mounted in a variety of configurations (see Figure 6).

- The trunnion bracket is used to permanently mount the speaker on the dashboard or other accessible areas, while permitting the speaker to be tilted to a desired angle.
 - The hanger bracket on the speaker housing permits temporary mounting, such as on an automobile window. The speaker must be removed from the trunnion bracket to use the hanger bracket.
1. Using the trunnion bracket as a template, drill the necessary mounting holes and secure the bracket with the self-tapping screws provided.

2. Position the external speaker onto the trunnion bracket, and secure it using the wing screws provided.

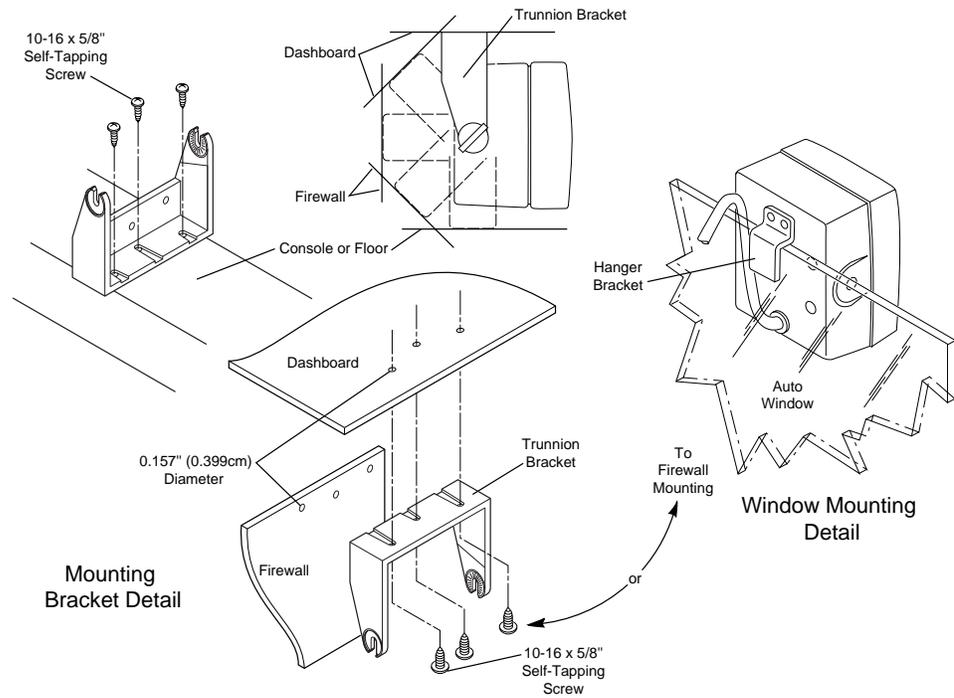

Figure 6 External Speaker Installation Detail

Optional Radio Frequency Power Amplifier (RFPA) Installation (XTS Only)

Mount the optional RFPA using the four self-tapping screws provided with the cable kit. Connect the cables as described below:

- A power cable with a 15-amp fuse attaches to the power amplifier and directly to the battery; connect the red wire to battery positive (+) and the black wire to chassis ground.



Caution

It is NOT good practice to connect the black lead directly to the negative (-) battery terminal; the RFPA could be damaged if there were a malfunction in the vehicle's electrical system.

Important Note: Failure to mount the red lead of the power cable kit directly to the battery may result in severe alternator whine interference. If severe alternator whine interference is present when the power cable is properly installed, a power line filter kit, TLN5277_, can be purchased to reduce the interference.

- An RF coaxial cable connects the XTVA antenna connector (J3) to the **RF IN** port on the RFPA.
- The RF cable from the antenna attaches to the **RF OUT** port on the RFPA.

Note: The radio's frequency band *must* match the RFPA's frequency band or they will not operate together correctly.

Anti-Skid Braking Precautions

General

The following installation suggestions and test procedures are recommended for vehicles with electronic anti-skid braking systems.

Installation Suggestions

Determine the location of the braking modulator box in the vehicle. This box is located in the trunk of Chrysler Corporation cars, and either in the trunk or under the dash in General Motors and Ford Corporation automobiles. A vehicle service manual may be helpful in finding the location of the braking modulator box.

Install the XTVA console in accordance with the following recommended guidelines:

- If the braking modulator box is mounted in the right side of the vehicle, mount the console on the left side to give as much space as possible between the box and the console. If the box is mounted on the left side of the vehicle, mount the console on the right side.
- Use the shortest practical length of antenna coaxial cable.
- Mount the antenna on the side of the car trunk opposite from the braking modulator box.
- Route all cables along the side of the vehicle opposite from the braking modulator box.
- **DO NOT** operate the transmitter while the vehicle is in motion with the trunk lid open.

Test Procedure

This test covers several different types of interference. Disturbance of the electronic anti-skid device can usually be detected in several different ways in the vehicle's braking system: by the vehicle's lights, by any irregular audible sounds, or by any change in the performance of the braking system itself.

Note: During procedure steps 1 through 6, however, none of the above conditions should be observed.

1. With the car gear selector in NEUTRAL or PARK, your foot off the brake pedal, and the engine running at a fast idle, key (turn the carrier on and off) the transmitter with and without modulation. Refer to the note above.
2. Repeat step 1 with your foot gently pressing the brake pedal. Refer to the preceding note.



WARNING

Disruption of the anti-skid braking system may cause the vehicle to move forward in addition to the lights and audible sounds mentioned above.

3. When performing this step, allow at least two car lengths of clear area in front of the vehicle while it is stationary. Press your foot on the brake pedal with just enough pressure to keep the vehicle from moving. Put the car in a forward gear with the engine running at a fast idle, then key the transmitter with and without modulation.
4. Drive at a moderate speed (15-25 mph [20-24 kph]) with your foot off the brake pedal, and have an assistant key the transmitter with and without modulation. Refer to the above warning.
5. Repeat step 4 with your foot lightly on the brake pedal to turn on the brake lights. Refer to the above warning.



WARNING

Severe disruption of the electronic anti-skid braking system may cause loss of control of the vehicle in steps 6, 7, and 8.

6. Increase the vehicle speed to 25-30 mph (40-48 kph). Decelerate slowly and come to a stop. As you are doing this, have an assistant key the transmitter with and without modulation. Refer to the above warning.
7. While making abrupt stops from 20 mph (32 kph), have an assistant key the transmitter with and without modulation. Refer to the above warning.
8. If no interference or disruption is noticed, repeat step 7, making abrupt stops from 30 mph (48 kph). Refer to the above warning.

If no malfunctions are observed in performing the above steps, it can be assumed that no apparent problem exists and the car can be released to the customer.

If any of the above steps results in a brake malfunction, contact the car manufacturer's service department as soon as possible, and remove the radio from the vehicle. **DO NOT** complete the installation.

Installation Checkout

After completing the installation of the vehicular adapter, check all electrical wiring for tight connections. Also, check all mechanical parts for tight and secure mounting.

Check for proper operation of the console, microphone, speaker, RFPA, and radio as described in the User Guide, Motorola publication 68P81088C76. Before placing the radio in the XTVA, check to see that the universal connector cover has been removed from the radio's universal connector, and an RF adapter is installed.

Note: If alternator or other vehicular noise is present in the received signal or in the transmission, refer to "Reducing Noise Interference in Mobile Two-Way Radios," Motorola publication 68P81109E33.

Theory of Operation

3

General

Note: All part numbers and part designators used in this section are for revision level “B” XTVA consoles. Please refer to the schematics and electrical parts lists at the back of this manual for the associated part and pin numbers.

The Motorola ASTRO XTS/DIMETRA MTP Vehicular Adapter (XTVA) is designed to work in conjunction with XTS and MTP series portable two-way radios.

Connection between the radio battery and the XTVA console is made through the charger contacts (P8) at the bottom of the console pocket. Through these contacts, the console’s charger circuitry automatically charges the radio battery.

Other connections between the XTVA console and the radio are made via the universal and RF connectors on the side of the radio.

When the radio is inserted into the console pocket and secured in place (by pushing either the pocket actuator, or the radio itself, until the radio is latched), the contacts of the console’s universal connector assembly automatically mate with the radio’s universal connector and RF adapter contacts. This makes control of all basic radio functions available to the XTVA. The hand-held control head (HHCH) microphone, optional external speaker, and rooftop antenna are also automatically connected to the radio when it is latched into the console.

For an XTVA without the optional external speaker, all the controls on the top of the radio can be used. Received message audio is emitted from the radio’s speaker, and the loudness is adjusted using the radio’s volume control. The console’s volume control is inoperative in this basic XTVA configuration.

For an XTVA with the optional external speaker, all operation of the radio, as described in the applicable radio’s User Guide, apply to operating the radio with the XTVA and the external speaker, except that:

- Audio is emitted from the external speaker and loudness can be adjusted using the XTVA console’s volume control. The radio’s volume control and speaker are inoperative when the external speaker is being used.
- The loudness of anticipated calls can be set in advance. Adjust the volume by pressing and holding Side Button 3 (monitor button) on the side of the radio, and then rotating the applicable volume control until a comfortable listening level is attained.

- In the case where HHCH microphone is used, the up/down volume button on the HHCH controls the speaker volume (the radio and XTVA volume control are disabled). A tone is emitted from the appropriate speaker to aid in determining a comfortable volume setting

Circuit Description

When reading the following circuit descriptions, refer to the console functional block diagram, Figure 7, and the schematic diagram at the back of this manual.

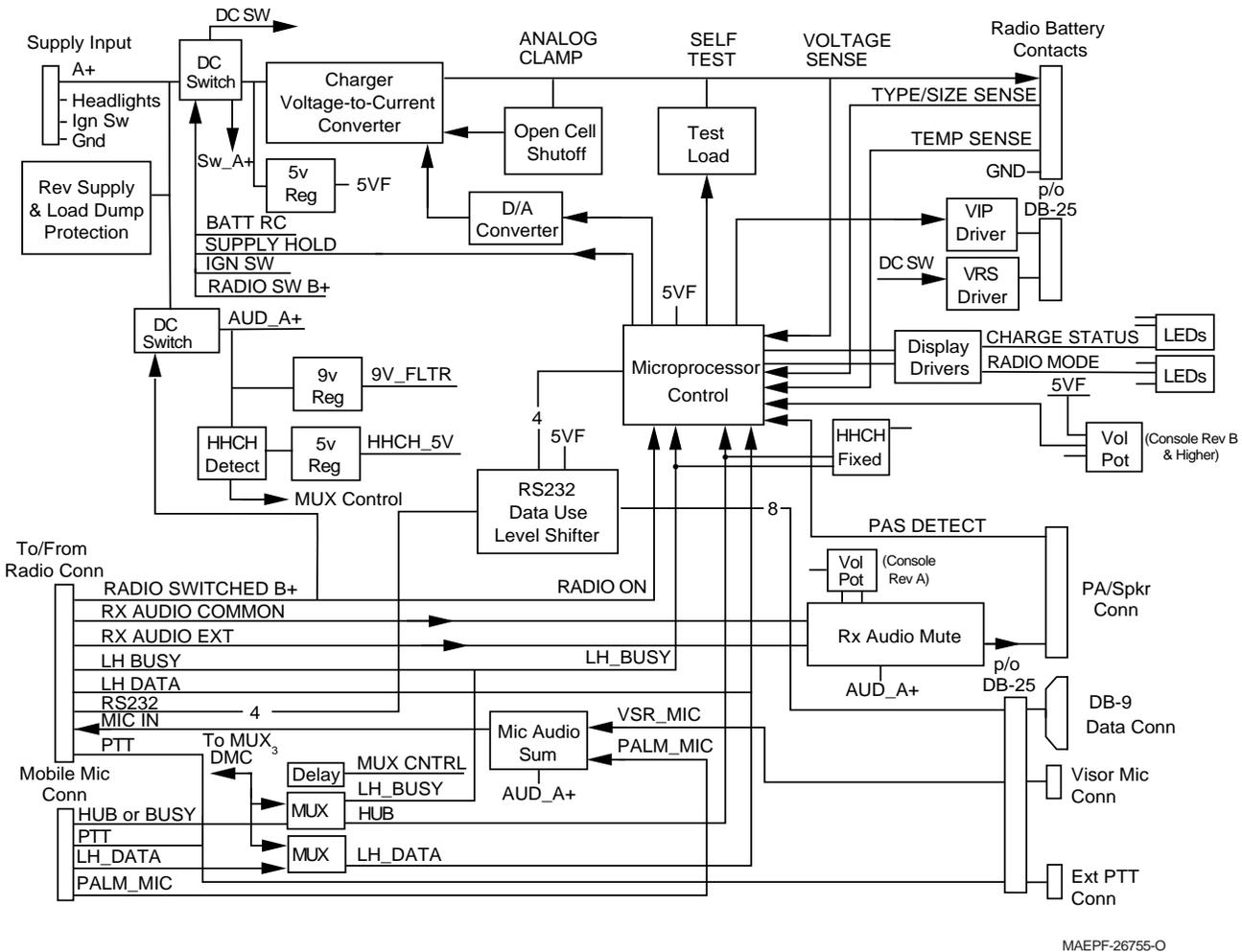

Figure 7 Console Functional Block Diagram

Charger

Note: To ensure proper battery contact, remove all labels and residual adhesive material from the battery before inserting it into the XTVA.

Connection between the radio battery and the XTVA charger is made via charging contacts in the XTVA console. Through these contacts, the charger automatically charges the radio battery. At first, the charger makes an assessment of battery status. Batteries with terminal voltage or temperature that is too high or too low (outside a predetermined window) are precharged at a reduced rate for a short period of time.

The battery voltage and temperature are monitored, and when the proper condition exists, a rapid-rate charge, 0.35C rate (approximately one-third the current rating of the battery), proceeds. The rapid rate continues until one (or more) of the following occurs:

- a. the rate of temperature rise and the rate of voltage decrease are exceeded
- b. the voltage limit (10.3V) is reached
- c. the temperature limit (45°C) is reached
- d. rapid charging times out (2.4 hours)

These conditions indicate charge complete, and the charger switches to a trickle rate of 0.05C.

The charger consists of the following circuits:

- a 5-volt regulator (U7),
- a microprocessor (U5),
- a digital-to-analog converter (DAC) (U3, R74-81),
- a current regulator (Q1, Q2, Q3, Q13, and U3), and
- a self-test, switchable load (Q17, R68-71).

The vehicle A+ battery voltage (13.8 Vdc) is applied, via the dc switch, to the 5V regulator (U7), which provides supply voltage to the microprocessor (U5). When the radio/battery is inserted into the XTVA, sensing of battery connected is processed by the dc switch (Q6, Q19 and Q4), which connects the charger to A+, and charging begins. The microprocessor interrogates the radio battery for type and temperature by measuring the voltage at the R_C (code) and R_T (temperature) battery contacts. The valid R_C values identifying the designated battery type are as follows:

R_C Resistance	Battery Type
5.1 k Ω	Ultra-High Capacity, NiMH
10 k Ω	Ultra-High Capacity, NiCd

The voltage at the R_T contact is pertinent because the processor is programmed to apply the rapid charge current rate only if the battery temperature is between 10°C and 40°C. Once the rate resistor (R_C) is determined, and the battery temperature is within the prescribed limits, the charger will begin supplying rapid-rate charging current.

The processor illuminates the XTVA's red LED, indicating a rapid-charge condition. If the battery temperature is colder than 10°C or hotter than 40°C (outside the prescribed limits), the charger will apply the trickle current rate, and the processor will illuminate the XTVA LED to an orange color. When the battery temperature changes to within the limits, the charger will begin its rapid-charge rate and the LED will turn red.

After approximately three hours, or when the battery voltage becomes 10.3V or the temperature reaches 45°C (whichever occurs first), the microprocessor will reduce the charge current to the trickle rate and the LED will turn green. This rate will be maintained until the battery is removed.

The charger compensates for current consumed by the radio. When the radio is turned on in the console, the XTVA circuitry senses that the radio's switched B+ signal is high, and an additional 70mA is added to battery charging current. During radio transmissions, the radio sends a TX data message, via SB9600 bus, to the XTVA circuitry, causing an additional 800mA to be added to the battery charging current.

Note: If a totally discharged battery is placed into the XTVA console, the radio receiver will begin to function normally within a few seconds. It is a good practice to wait for about 30 seconds before attempting to transmit when using a high-power radio, and transmission should be kept to a minimum for the first few minutes. Low-power radios will allow normal operation sooner.

Input Line Voltage

Power from the vehicle battery (input line voltage, A+) enters the console at connector J2, pin 1. The maximum specified A+ voltage is 16.6 Vdc. Zener diodes VR29 and VR70 are transient-voltage suppressors that clamp incoming transients and provide reverse supply protection.

5V Regulator (U7)

The 5-volt regulator (U7) and associated circuitry supply regulated 5 Vdc to the microprocessor (U5) and the level-shifter IC (U8). Capacitors C39, C89, C40, and C80 form a filter to reduce noise on the 5-volt supply line. The filter circuitry also improves the RF noise immunity.

Microprocessor (U5)

The microprocessor (U5) communicates with the portable radio, via the console connector arm, to the radio side connector, using the SB9600 data bus. The microprocessor informs the radio of connection of any XTVA accessories, and monitors and controls the XTVA charger. Microprocessor U5 enters into a self-check mode whenever:

- a. supply voltage is received from the vehicle ignition switch or (consoles with rev "B" and higher) the radio is turned on, and
- b. the radio battery is making connection.

During the self-check mode, the microprocessor internally checks its memory and internal read-only memory (ROM). Externally, the microprocessor tests the charger. The red and green LEDs will be scanned on and off, indicating the status of the XTVA system after self-check. Refer to the troubleshooting section for the LED states.

RS232 Level Shifter (U8)

RS232 level shifter U8 is used to connect a data terminal to the radio. It translates signal voltage levels from a data device to transistor-transistor logic (TTL) levels for interface to the portable radio digital circuitry.

Data connection to the XTVA is made through a data cable connected to DB25 connector J5. Once the data device is connected and turned on, the data transfer operation is started. During data transfer operation, the voice mode will be paused in the portable radio. Four RS232 signals originate in the radio, and four others are produced by the XTVA microprocessor, based on radio SB9600 signals.

Optional PA/Speaker Volume Control

Although the external speaker and associated audio cable are optional, the supporting circuits are standard and part of every XTVA's printed-circuit board (PCB) circuitry. A loop between pins 3 and 6 on jack J1 is used by the XTVA to detect the presence of a speaker. When a short is detected across these pins, the XTVA signals the radio to mute its speaker and disable its volume knob. The volume control and all XTVA audio circuits are powered by switched audio A+, which is active whenever the radio is turned on. Amplifier circuits U4-2, -3, and -1 process the radio's audio output for use as the PA/speaker's input signal.

The radio's output is balanced. Therefore, amplifier stage U4-2 unbalances the signal and minimizes squelch transients. When audio is squelched, the radio output has a zero Vdc level and when unsquelched, it has a Vbatt/2Vdc level + audio. The PA/speaker has a single-ended, capacitively-coupled, low input (2k Ω) impedance. The buffer stage (U4-1) accepts signal from U4-2 for drive voltage to the PA/ Input. The PA/speaker drive signal is muted unless receiving.

The XTVA's volume control is:

- (rev. "A" consoles) in line with the audio signal path, or
- (rev. "B" or higher consoles) connected between regulated 5V supply and microprocessor U5 input pin 49.

In rev. "A" consoles the volume control trims the audio signal level. In rev. "B" or higher consoles, the volume control sends position indication to U5 by a dc voltage. The dc voltage is converted to an SB9600 message by U5, then sent to the radio to adjust the audio signal level.

In the radio standby mode, U4-3 pin 8 is high and turns on transistors Q7 and Q24, which mutes the audio input. When a received message unsquelches the radio, the signal at U4-3 pin 8 goes low, which turns off the transistors.

Resistors R47 and R14, and capacitor C94 form a muting delay circuit. The delaying action in this circuit prevents any unsquelch dc voltage transient originating in the radio from causing a "pop" sound in the PA/speaker.

Mobile Microphone Selection and Bias

Microphone connection to the XTVA is made via the console connector jack, J4, which accepts a standard- or enhanced-type microphone.

The HHCH microphone has an internal microprocessor that uses serial-data communication to the radio. The data path is put into use by automatic switching of signal routing, performed by Q9 and U2. The HHCH microphone draws supply current through R85, causing Q9 to conduct and U2 to switch signal paths.

Whenever the portable radio is turned on, R93, VR30, and R55 provide bias voltage (+9 Vdc) to the microphone (J4 pin 5) and supply to the multiplexer (MUX) (U2). Transistor Q5 conducts when driven by transistor Q18. Transistor Q18 monitors the radio's OPT B+ line and drives Q5 when the radio is on.

Charger LED Indicator Drivers

Transistors Q10 and Q11, display LED drivers, conduct for particular charger conditions. They are driven by signals from microprocessor U5. Transistor Q11, through current-limiting resistor R87, controls the green illumination of LED D1. Transistor Q10, through current-limiting resistor R86, controls the red illumination of LED D1. Similar transistors Q16 and Q21 control the radio mode LEDs in D2

Dimmed LED illumination is controlled by XTVA installation wiring to the vehicle headlight switch. When conditions are dark, LED brightness is reduced by headlights on. The headlight A+ signal at J2 pin 4 operates Q22, causing conditions through dual diodes D12 and D13, and resistors R209 through R212. Voltage at driver transistor bases becomes reduced, causing lower LED current when on.

LED disabling (typically custom installation for surveillance operation, for example) operates by grounding connector J5, pin 13 through diodes D10 and D11, causing driver transistor bases to be taken below 0.7 Vdc.

VRS/PAC•RT Control

The XTVA circuit board includes a vehicular repeater system (VRS) control circuit, consisting of transistor Q15 and associated circuitry. Transistor Q6 monitors the presence of a radio in the XTVA console.

When the radio is inserted into the XTVA console, Q6 stops conducting, causing Q15 to conduct. This logic low is routed to the VRS output to control the VRS; its internal pullup resistor enables the VRS. It is recommended that the installer include a user switch across this output to VRS to provide a user-selectable VRS disable. The closed setting of the switch is used when the vehicle (so equipped) is in the out-of-service condition, such as off duty.

DC Switches

To minimize vehicle battery current drain, the XTVA is designed to disconnect itself from vehicle supply when not in service. XTVA subcircuits become powered on-demand only (see Table 3 on page 23). In summary:

- If no radio is loaded, all circuits are turned off.
- If a radio is loaded but not turned on (provided the ignition switch *is* ON), only the charger section turns on when it detects a radio battery in the charger pocket.
- If a radio is loaded and turned on, all audio circuits turn on.
- In addition (provided the ignition switch is ON), the XTVA includes a time-out function which allows the charging circuit to continue to operate for 1/2 hour after the ignition is switched off.

Table 3 XTVA Functions

Condition	Charger	Audio Circuit	VRS	RS232
No Radio:	OFF	OFF	ON	OFF
Radio Loaded:				
Radio OFF:	ON*	OFF	OFF	OFF
Radio ON:	ON*	ON	OFF	ON

* — Provided the ignition switch is ON

Q19 driver and Q6 detector operate charger dc switch Q4. Components R216, R166, R167, R330, and R208 hold Q6 in conduction until a radio battery is connected by loading a radio. The voltage at Q6 gate drops due to (console rev. "A") the contact of the radio battery code resistor, or (console rev. "B" and higher) contact across the universal contact ground (pin 8) and the XTVA's grounded charge contact; Q6, Q19, and Q4 switch to opposite states. Diode D9, supply hold, allows processor U5 to control XTVA power down.

The audio section dc switch, Q5, is operated by Q18. Q18 conducts only when the radio is turned on by radio signal option B+ at connector J6, pin 5.

Maintenance

4

Preventive Maintenance

Note: All part numbers and part designators used in this section are for revision level “B” XTVA consoles. Please refer to the schematics and electrical parts lists at the back of this manual for the associated part and pin numbers.

Note: The revision A console has a short extension cable (P/N 3085361C01) with a fuse block connected to the power supply connector, J2. No user-serviceable parts are inside the fuse block, and no attempt should be made to tamper with or remove this extension cable.

Periodic Inspections

Slow degradation of equipment performance, if left uncorrected, can lead to costly equipment downtime and repair. Preventive maintenance (PM) differs from corrective maintenance in that minor equipment operating deficiencies can be corrected before breakdown occurs. Periodic and systematic PM inspection schedules should be set up to keep the equipment operational and failure free. The environment in which the equipment is being used will determine the frequency of PM schedules. As a rule, PM should be performed at least once a year.

The periodic inspections should include:

- Visual inspection of cables for frayed or oxidized leads.
- Ensuring that battery connections are free from oxidation or corrosion.
- Ensuring that contacts on the radio’s universal connector and battery and the Vehicular Adapter console are clean and free from foreign material.
- Checking the battery and universal contacts for wear.
- Checking the external rooftop antenna for clean and rust-free mounting.
- Checking for tight connection of the console-to-antenna cable connectors.
- Checking the system ground lead (black) for clean and proper electrical contact.
- Checking all jack and plug connections for tightness and good electrical pin contact. Pins should be visually checked for wear.
- Checking for loose components. Checking component assemblies and mechanical assemblies for tight and secure installation. Many XTVA failures can be traced to poor installation.

- Inspecting all mounting brackets and associated mounting screws for secure and tight mounting.
- Checking for overheated or discolored components.
- Checking for proper (13.8Vdc) vehicular alternator charging. Vehicular voltage can vary from as low as 10Vdc to as high as 18Vdc without being evident to the operator; however, it can affect XTVA operation.

Cleaning Procedures

In areas of high dust or salt conditions, periodically check the mechanical operation of the console's battery contacts. If contact movement requires excessive effort, clean any dust or salt deposits from the moving parts as described below. Cleaning may be accomplished by performing the following procedure:

1. Remove the console from the vehicle and place it rightside-up on a flat working surface. The working surface should offer protection from scratching to the console's surfaces.
2. Referring to the "Disassembly/Reassembly Procedures" in the "Corrective Maintenance" section of this manual, disassemble the unit for cleaning.
3. Using the recommended cleaning agent, clean the external surfaces of the console and the radio alignment surfaces in the pocket housing. These surfaces should be cleaned whenever a periodic visual inspection reveals the presence of excessive dust, grease, and/or grime.

The only recommended agent for cleaning the internal and external plastic XTVA surfaces is a 0.5% solution of a mild dishwashing detergent in water (one teaspoon of detergent per gallon of water).



Caution

The effects of certain chemicals and their vapors can be harmful to some types of plastics. Aerosol sprays, tuner cleaners, and other such chemicals should be avoided.

4. Should they require cleaning, the internal circuit boards and components can be cleaned when the console is disassembled for servicing or repair. The only factory recommended liquid for cleaning the circuit boards and their components is isopropyl alcohol (70% by volume). Make sure to avoid applying alcohol to plastic connector housings on the circuit board. Allow sufficient time for the circuit board to dry, since alcohol can damage plastic housings.

Note: When the XTVA is used under adverse marine conditions, the circuit board must be cleaned of salt deposits at least twice a year.

Isopropyl alcohol may be applied with a stiff, non-metallic, short-bristled brush to dislodge embedded or caked-on materials located in hard-to-reach areas. The brush stroke should direct the dislodged material out and away from the inside of the console.

Alcohol is a high-wetting liquid, and can carry contamination into unwanted places if an excessive quantity is used. Make sure that the controls are not soaked with the liquid. When the cleaning process is complete, use a soft, absorbent, lintless cloth to dry the area.

Note: Always use a fresh supply of alcohol and a clean container to prevent contamination by dissolved material from previous usage.

5. Reassemble the console, reversing the disassembly procedure.

Corrective Maintenance

Introduction

Efficient corrective maintenance requires an orderly and logical troubleshooting procedure for identifying and locating malfunctions in the XTVA's internal or external circuits. Troubleshooting and repair will be greatly simplified by becoming familiar with the overall XTVA and portable radio operation.

This section provides detailed information required to isolate malfunctions to the XTVA's internal or external circuits. The troubleshooting chart at the end of this section provides information on possible circuit failures and related symptoms, and probable malfunctioning stages.

Generally, if the XTVA is totally inoperative, it may be assumed that the vehicle's battery is completely discharged, the fuse is blown, or the power lead is opened. However, if the XTVA is partially operative, it may be assumed that the batteries are serviceable and that one or more internal or external functional XTVA circuits are defective or marginal. Using diagrams, the troubleshooting chart, the voltage table, and deductive reasoning, the defective circuit may readily be found.

To further aid in analyzing the symptoms and possible causes of the malfunction, check: RF power output (using an in-line wattmeter), audio deviation, and current drain. Once the general problem area of the XTVA is identified, careful use of a dc voltmeter, ohmmeter, and/or oscilloscope should help isolate the problem to a defective component.

Test Equipment and Service Aids

Table 4, "Recommended Test Equipment," lists the bench test equipment recommended to properly service the XTVA. Refer to the appropriate portable radio's service manual for the recommended radio test equipment. For field servicing, the vehicle's battery is an adequate power source. Battery-operated test equipment is recommended when available.

Table 4 Recommended Test Equipment

Model No.	Name	Characteristics	Application
R-2001, R-2002, or R-2200	Service Monitor	-----	Audio circuit, testing, frequency/deviation, power output.
S-1347	DC Power Supply	0-20Vdc, 0-5 Amps; current limited	Power supply for bench testing.
S-1053	AC Voltmeter	1mV to 300mV RMS, -72dB to +52dB; 10M Ω input impedance	Audio voltage measurements
R-1028	Solid-state Oscilloscope	-----	Waveform measurements
R-1001	Digital Multimeter	High input impedance	DC voltage, resistance measurements
3085992B01	Service Cable	-----	
NTN8982	Troubleshooting Kit	-----	Audio and charging circuit troubleshooting

See your Motorola sales representative for aid in ordering test equipment. The sales representative will analyze your requirements and help you select the latest available equipment and service aids to suit your individual needs.

MAV-PACK 3 (VID-952)

The VID-952 Motorola Audio/Visual Package (MAV-PACK) is a videotape training program on leadless component repair techniques. This VHS format video cassette and supplemental literature describe the removal and replacement of leadless components using the following specialized equipment:

- RRX-4033 Laurier Hot Gas Bonder or equivalent
- RPX-4234 Regulator and Hardware Kit
- 0180386A62 Heated Tweezers
- RSX-1002 Desoldering Station
- RSX-1008 Weller Soldering Station

This MAV-PACK is strongly recommended for technicians who intend to service this and other Motorola products using leadless components. This VHS videotape is in standard half-inch format. This MAV-PACK, as well as others, is available from:

Motorola C&E, Inc.
National Service Training Center
1300 N. Plum Grove Road
Schaumburg, Illinois 60173

Troubleshooting

Refer to the troubleshooting and voltage charts at the back of this section to isolate a malfunction to a defective circuit. Follow the flow through the chart, check each observation, and answer each question. As an aid in understanding the operation and functioning of a particular circuit, refer to the appropriate paragraphs in the “Theory of Operation” section of this manual.

If a circuit board must be tested, it may be necessary to remove it from the housing and test it outside of the enclosure. In this case, use the XTVA Troubleshooting Kit (P/N NTN8982_) and refer to the “XTVA Troubleshooting Kit Procedure,” starting on page 36. Always use care to protect the board from being accidentally shorted out.

Disassembly/Reassembly Procedures

Disassembly Procedure

Disassemble the console by performing the following procedure:

Note: Any time the unit is disassembled, the thermal pad (9), if present on the PCB or chassis, should be inspected and replaced if compressed, torn, or otherwise damaged. Some console versions do not require a thermal pad.

Refer to the exploded view and exploded view parts list on page 54. Items in parentheses () refer to item numbers in the exploded view.

Preliminary Disassembly

1. Unlock the console, press the eject button to remove the radio from the console, and disconnect all cables from the console (including the microphone cable). Remove the key (24) from the console lock (23).
2. Using a 4mm hex Allen wrench, remove the trunnion screws (25) from the sides of the unit, and slide the console out of the trunnion. Replace the trunnion screws in the console to prevent the nuts from falling out later. Place the console on a flat working surface.

Note: If servicing of the console involves replacing the battery charge contacts (12), the product label (17), located on the back housing, must be removed. If this does not apply, skip to step 4.

3. Turn the console upside-down so that the product label (17) faces upward. Remove the product label using a pair of tweezers, making sure not to damage the label or scratch the back housing.
4. Using a T-15 TORX driver, remove the five screws (15) from the back housing (14) and set them aside.
5. While holding the front and back housings together, turn the console rightside-up and place it on a flat surface.
6. Carefully remove the front housing (1) and set it aside.
7. Remove the lock assembly (23) and set it aside.

Note: The next step requires the use of both hands. Do not push on the purple pocket eject button (27), since this will prevent the pocket from latching in place. Do not apply excessive force on the kicker (4) as this may cause permanent damage to the kicker spring (3).

8. While pressing inward on the pocket lid housing (26), rotate the kicker lever (4) at the end of the pocket by deflecting the kicker arm until the pocket is free to move. Continue to push on the pocket actuator until the pocket latches.

Note: If the reason for disassembly is to use the NTN8982_Troubleshooting Kit, skip the steps below and proceed to the “XTVA Troubleshooting Kit Procedure” on page 36 for appropriate instructions.

9. Remove the RF connector (part of 31) from the chassis (8) by lifting it out of the chassis. This may require slight rocking of the connector to dislodge it. Make sure to apply force to the connector body only and not to the crimped cable connection or the cable itself. Do not pull on the cable.



Caution

While performing the next step, make sure not to pull on the flex circuit ribbon cable.

10. The universal coax subassembly (31) is now exposed. Gently twist (in a clockwise direction) and pull outward on the header until it clears the pocket lid housing (26). Then, pull the entire assembly upward, being careful not to pull on the flex circuit ribbon cable. Set the subassembly next to the unit.
11. Gently lift the chassis subassembly (8) away from the back housing (14), and set it on a flat working surface for further disassembly.
12. Gently press the purple pocket eject button (27) to disengage the pocket housing (5), and guide it out of the chassis. The eject spring (10) will fall off during this step. Set the pocket housing subassembly aside.
13. A contact insulator is located on the back side of the chassis, above the rectangular opening, and is attached to the chassis with adhesive. The insulator may be removed with a flat-head screwdriver, but this should not be done unless replacement is intended.

14. Referring to Figure 8, gently lift up the opening frame on the ZIF flex circuit connector, located on the PC board assembly (11), and slide the flex circuit ribbon out of the connector.
15. If necessary for replacement, remove the link (2) from the universal subassembly by twisting the link and prying it out of the float bracket holes.
16. The universal header assembly should not be disassembled any further.

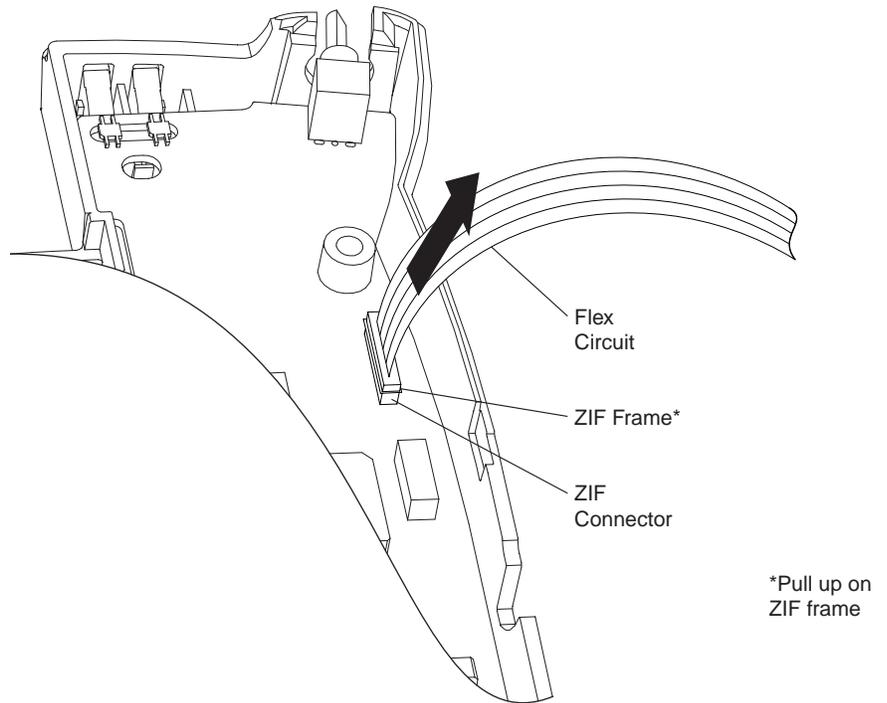

Figure 8 Disconnecting the Flex Cable

Disassembling the Pocket Subassembly

17. Remove the pin (30) and the purple universal bushing (29) from the pocket housing (5) by pulling upward on the pin.
18. Remove the kicker (4) from the pocket (see Figure 9):

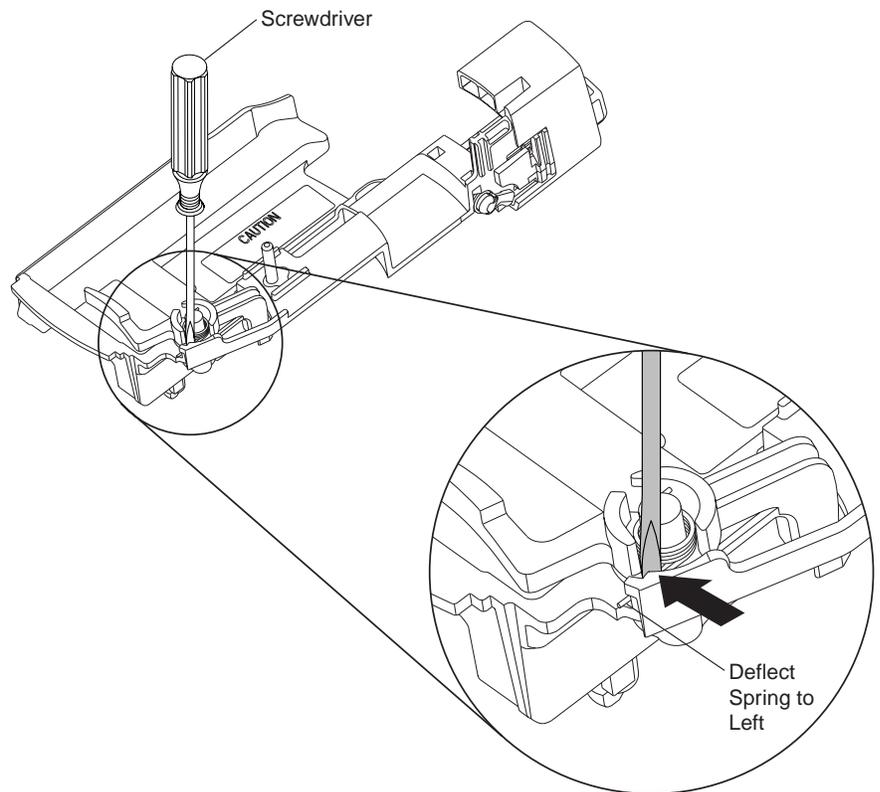

Figure 9 Removing the Kicker

- a. Using a small, flat-bladed screwdriver, deflect the long arm of the kicker spring (3) in the direction the spring is wound, until the arm clears the plastic.
 - b. Rotate the kicker counterclockwise until it reaches the stop.
 - c. Pull the kicker up and away from the pocket.
 - d. Remove the kicker spring.
19. Referring to Figure 10, remove the pocket lid housing (26):

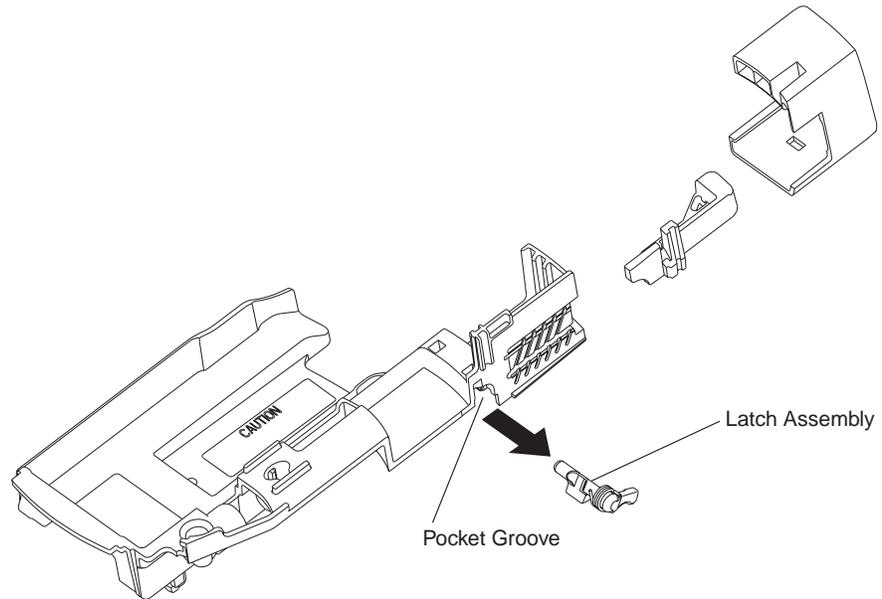

Figure 10 Removing the Latch Assembly

- a. Turn the pocket housing (5) upside down, so that the label (28) side faces downward.
 - b. Insert a small, flat-bladed screwdriver at the base of the pocket lid housing (26), and wedge the blade between the pocket lid housing and the pocket housing.
 - c. Twist the screwdriver slightly clockwise while pulling outward on the pocket lid housing. This will enable you to clear the snap feature in the middle of the pocket lid housing and slide the pocket lid housing away from the pocket housing.
20. Remove the purple eject button (27) from the pocket by sliding it out of the groove.
21. Referring to Figure 10, pull on the latch assembly (6) and slide it out of the pocket groove.
22. Remove the printed circuit board (PCB) assembly (11) by lifting up on the back end of the PCB (the end with connectors). Pivot the PCB at the volume knob until the PCB clears the volume knob opening in the back housing (14).

Note: If charge contacts (12) require replacement, make sure step 3 was performed. If this does not apply, skip step 23 and continue with step 24.

23. Lift the “hooked” end of a charge contact (12) approximately 90° and pull it away from the back housing. Repeat this procedure for the remaining three contacts.

24. The lightpipe (18) can be removed by lifting the tab at its base and pulling the lightpipe out.

Reassembly Procedure

Reassemble the console by reversing the disassembly procedure. Pay particular attention while performing the following steps:

Reassembling the Back Housing Assembly

1. The four PCB contacts (13) must first be placed into the back housing (14) slots before reinserting the four charge contacts (12). The PCB contacts have locating tabs on both edges that must be inserted into their respective grooves in the back housing.
2. When inserting the four charge contacts (12), insert the widest portion of each contact slightly beyond the slot opening, then rotate it downward until it bottoms out. Do not try to force the contact into position; this will permanently damage it.
3. Do not replace the nameplate label (17) until the entire unit has been reassembled and the fasteners tightened together.
4. Referring to Figure 11, insert the PCB assembly (11) by holding the PC board at an angle to the back housing (14) while inserting the volume knob shaft into the volume knob opening in the back housing. Pivot the board downward the housing until it is back in place. Do not press down the board at this time because some contacts may not be properly seated.

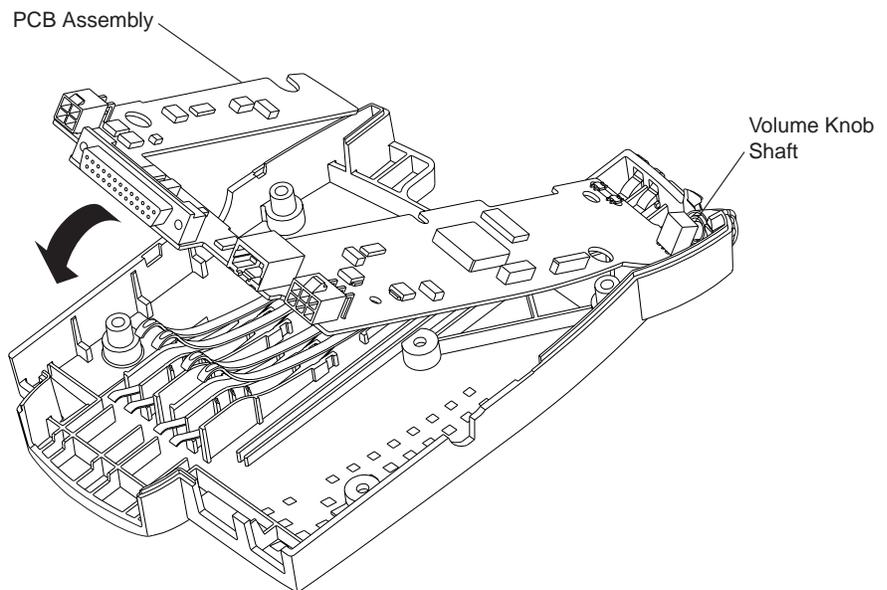

Figure 11 Replacing the PCB Assembly

Reassembling the Pocket Subassembly

5. Referring to Figure 12, slide the latch assembly (6) part way into the pocket housing's (5) groove, with the latch's pawl (spring end) facing outward. Align the tail of the spring with the slot in the pocket wall, then slide latch and spring the rest of the way into the groove.

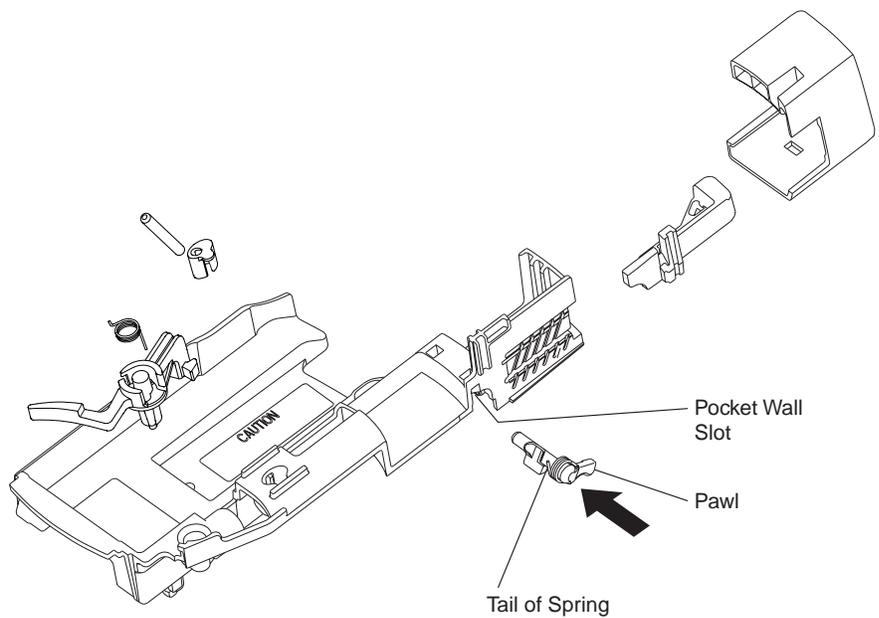

Figure 12 Reassembling the Latch Assembly

6. Turn the latch arm counterclockwise so that the spring is loaded. While pushing on the latch pawl and holding it in this position, slide the purple release button inward on its groove. Continue to hold the latch in the loaded position.
7. Position the pocket lid housing (26) so that the small rectangular opening in the lid is in the same plane as the wedge-shaped snap feature on the pocket housing, then slide the pocket lid housing inward until it snaps in place.
8. Install the kicker (4) in the pocket housing. Refer to Figure 13:

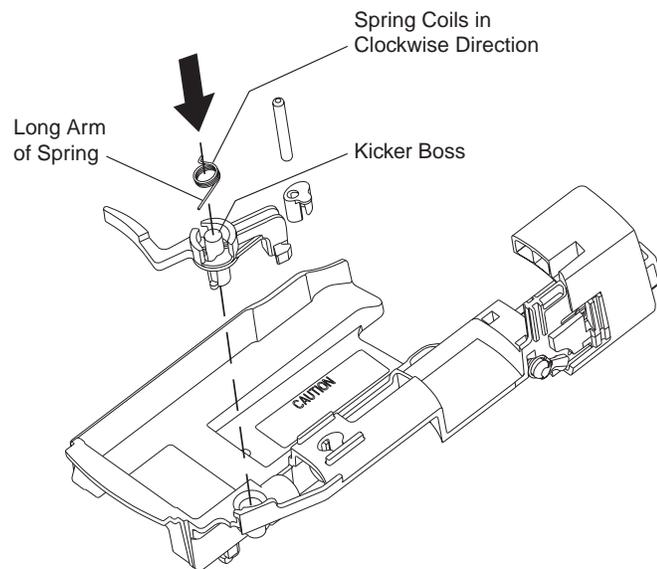

Figure 13 Installing the Kicker

- a. Hold the kicker (4) so that its curved arm is at your left and its longer, keyed shaft is pointed downward.

Reassembling the Chassis

- b. Insert the kicker spring (3) onto the kicker's short shaft so that its spring coils in a clockwise direction. The end of the spring with the straight (longest) arm should go in first and be in the opposite direction from the curved kicker arm.
 - c. Position the kicker shaft to match the hole opening in the pocket, then insert the kicker.
 - d. Lift the straight arm of the spring and rotate it in the direction the spring is wound and over the side wall until it is past the plastic. Then, bring the arm down to secure it in place under the extended portion of the side wall.
9. Insert the pin and bushing into the slot in the pocket.
 10. Reassemble the pocket assembly into the chassis.
 11. Turn the chassis/pocket assembly upside down and make sure that the tabs on the pocket are aligned with the slots on the chassis.



WARNING

The next step involves assembling the eject spring to the chassis. Perform this step carefully to avoid any personal injury as a result of the spring's popping loose. Use eye protection while performing this next step.

12. Insert each end of the eject spring eyelet onto the pocket boss first and then onto the chassis boss. This step does not involve stretching the spring.

Note: The next step requires use of both hands. Do not push on the purple pocket-release button, since this will prevent the pocket from latching in place.

13. Grasp the pocket at its base while holding the kicker clear of the chassis and pull down the pocket until it latches in place. This is confirmed by a distinct "click" sound.

Reassembling the Universal Header Subassembly

14. Assemble the universal link to the float bracket by first twisting and then pushing the link, so that the bosses on either side of the link are fully seated in the float bracket holes.
15. Lay the universal subassembly next to the back housing with the universal link facing the back housing and the RF connector pointing toward the top of the back housing (see Figure 14 for positioning of universal subassembly).
16. Hold the end of the flex circuit ribbon so that the text "THIS SIDE IN" faces toward the contacts and PCB, then insert the end into the ZIF connector. Secure the flex circuit ribbon end by pushing downward on the ZIF connector frame
17. Place the chassis into the back housing assembly. Make sure the charger contacts are not obstructed and do not protrude from the rectangular opening in the pocket.
18. While being careful not to pull or damage the flex, rotate the universal header subassembly clockwise until the RF connector points toward the bottom of the back housing assembly. (Refer to Figure 14.)

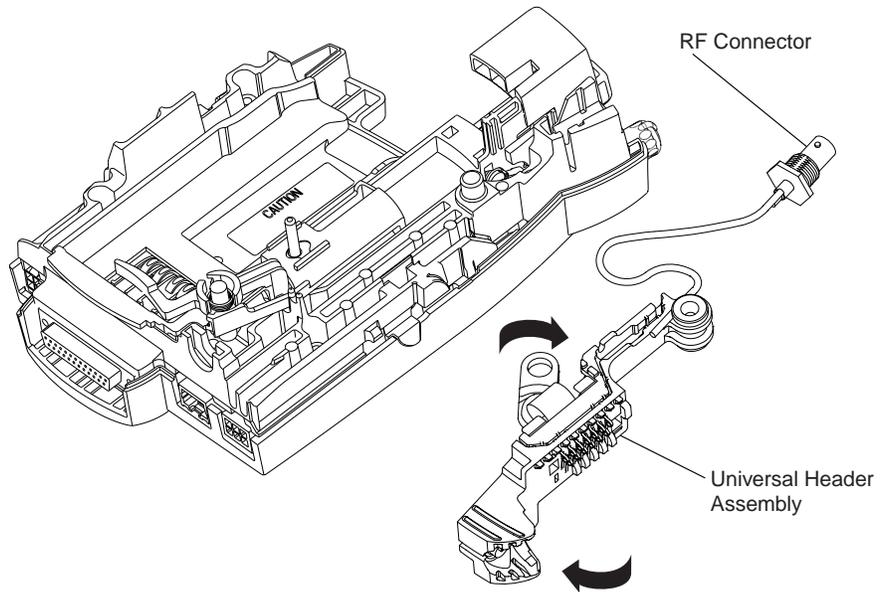

Figure 14 Reassembling the Universal Subassembly

Completing the Console
Reassembly

19. Align the hole in the universal header subassembly with the pin in the pocket and the hole in the link to the chassis boss. Push the universal header subassembly fully downward and under the corner of pocket actuator.
20. Insert the RF connector (mini-UHF or BNC type) into the slot in the chassis. Make sure that the washer is inserted in the slot and is making a positive ground connection.
21. Insert the coaxial cable into the retaining feature on the chassis.
22. Insert the two hex nuts into the slots so that the round side faces inward.
23. Insert the lock into the slot above the volume knob so that the gold dot faces upward.
24. Reassemble the top cover. Make sure the flex circuit ribbon is not pinched.
25. Turn the unit upside-down and torque the five back cover screws to 8 in-lb, using a T-15 TORX driver.
26. If the product label was removed while disassembling the unit, replace it in the recess.
27. Finally, inspect the coaxial cable for proper routing through the specified openings in the top cover. Ensure that the cable has not been dislodged from the cable retaining features.

XTVA
Troubleshooting Kit
Procedure

Note: This procedure is continued from step 9 of the disassembly procedure.

Refer to the exploded view and exploded view parts list on page 54. Items in parentheses () refer to item numbers in the exploded view.

Assembly Instructions



While performing step 1, make sure not to pull on the flex circuit ribbon.

Caution

1. Orient the console so that the volume knob (19) faces away from you and the DB-25 connector (on the back of the PCB) faces toward you. While holding the back housing (14) and the PCB (11) stationary, gently lift upward on both sides of the chassis (8) until the chassis disengages. Do not lift up on the PCB. Continue to lift up on the left side of the chassis while holding the right side stationary, thus rotating the chassis up and away from the back housing. Lay the chassis upside down next to the back housing.
2. Referring to Figure 8, gently lift up the opening frame on the ZIF flex circuit connector, located on the PC board (11), and slide the flex circuit ribbon out of the connector.
3. Be careful not to pinch the circuit ribbon flex during this step. Turn the chassis rightside-up. The flex should lie against the chassis as shown in Figure 15. Replace the front housing (1) on the chassis.

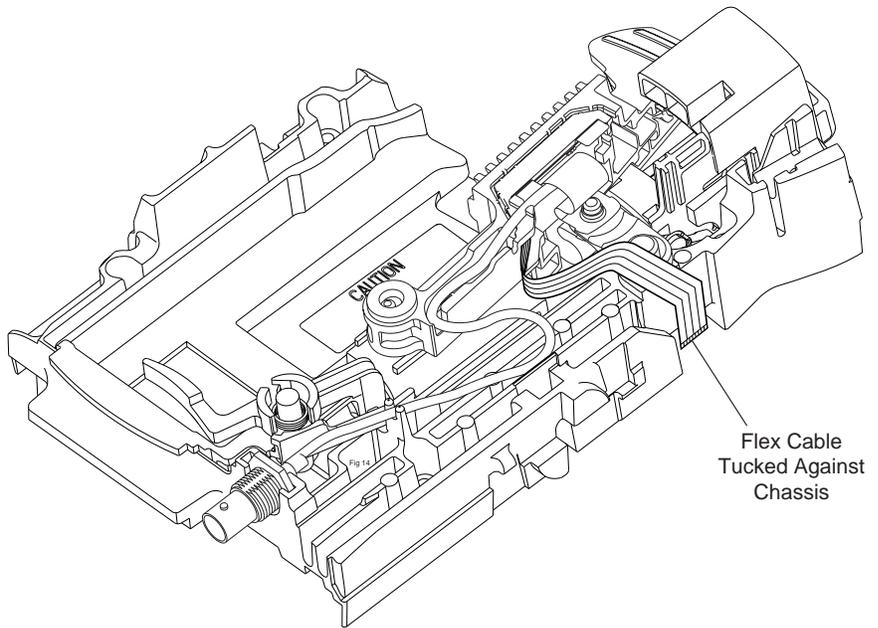

Figure 15 Flex Against the Chassis

4. Gently lift the PCB partly out of the back housing by grasping and lifting the bottom edge only. The PCB should pivot around the volume knob. While holding the board up with one hand, carefully remove the four gold PCB contacts (13) from under the four gold charge contacts (12). Place the PCB contacts to one side; **DO NOT LOSE THEM**. Lower the PCB back in place.

Note: Before performing step 5, verify that the power source is off.

5. Connect the power, microphone, and speaker cables to the back housing/PCB assembly.

6. Arrange the console on the bench so that the back housing/PCB assembly is to the left and the front housing/chassis assembly is on the right, with the chassis facing upwards. Ensure that the power, microphone, and speaker cables do not pull on the back housing/PCB assembly by securely fastening them to the workbench.

Note: Be extremely careful while performing the next step. Flexible circuit boards and ZIF connectors are easily damaged if mishandled.

7. Connect the ZIF connector end of the flex extender (part of NTN8982_) to the exposed end of the ZIF flex as shown in Figure 16. Hold the end of the flex circuit ribbon so that the text “THIS SIDE IN” faces upwards, and insert the end into the ZIF connector. Secure the flex circuit ribbon end by pushing down on the ZIF connector frame.

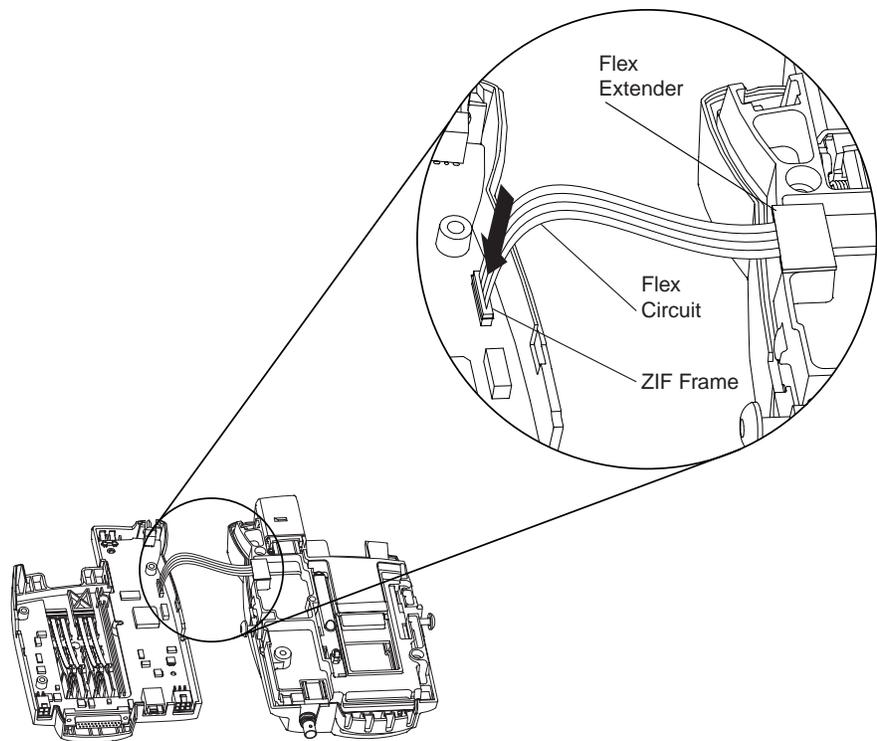

Figure 16 Connecting the Flex Extender

8. While holding the flex extender in place as shown in Figure 17, place the troubleshooting rear housing (second part of NTN8982_) on the XTVA front cover/chassis assembly. Make sure that the flex Extender is securely held in place by the troubleshooting rear housing.
9. Insert and torque the five back cover screws to 8 in-lb using a T-15 TORX driver.
10. Lift the front cover/chassis assembly and gently press the purple pocket release button to disengage and extend the pocket.

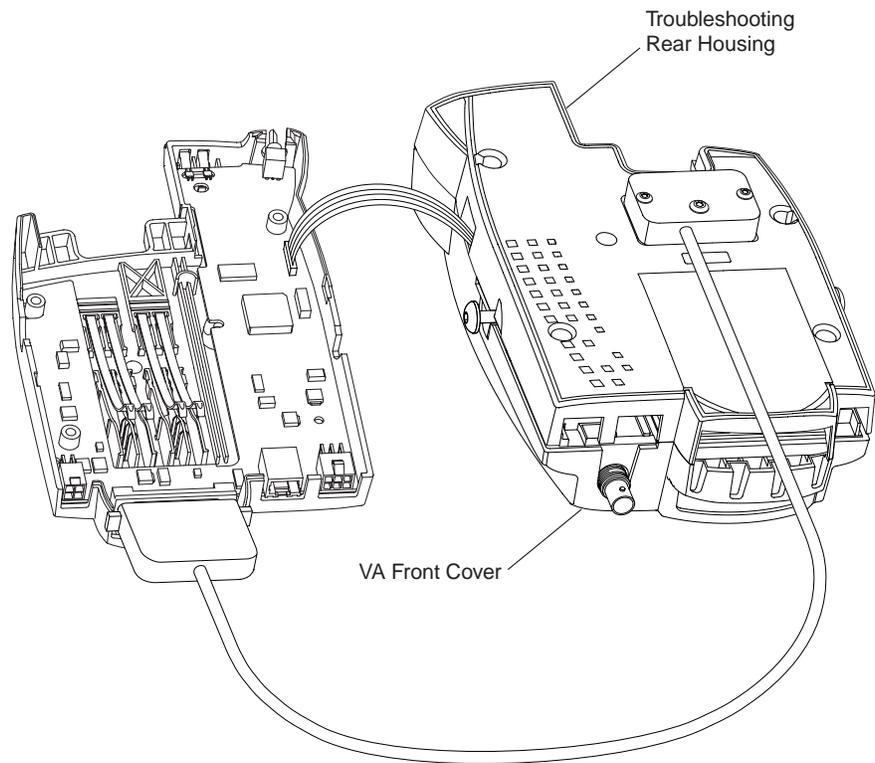

Figure 17 Placing the Troubleshooting Rear Housing on the Console Front Housing

11. Slide the radio into the pocket until it bottoms out.
12. Push down on the pocket actuator until the radio is securely latched in the console.
13. Lay down the front cover/chassis assembly and make sure the VA is arranged on the bench so that the back cover/PCB assembly is to the left and the front cover/chassis assembly is on the right with the chassis facing upwards.
14. Plug the db25 end of cable into the db25 port on the back housing/PCB assembly.

Note: Be extremely careful while performing the next step. Flexible circuit boards and ZIF connectors are easily damaged if mishandled.
15. Carefully grasp the free end of flex Extender and insert into the ZIF connector on the PCB. Secure the flex circuit ribbon end by pushing down on the ZIF connector frame, as shown in Figure 18.
16. Turn on the radio; turn on the power supply.
17. Begin troubleshooting.

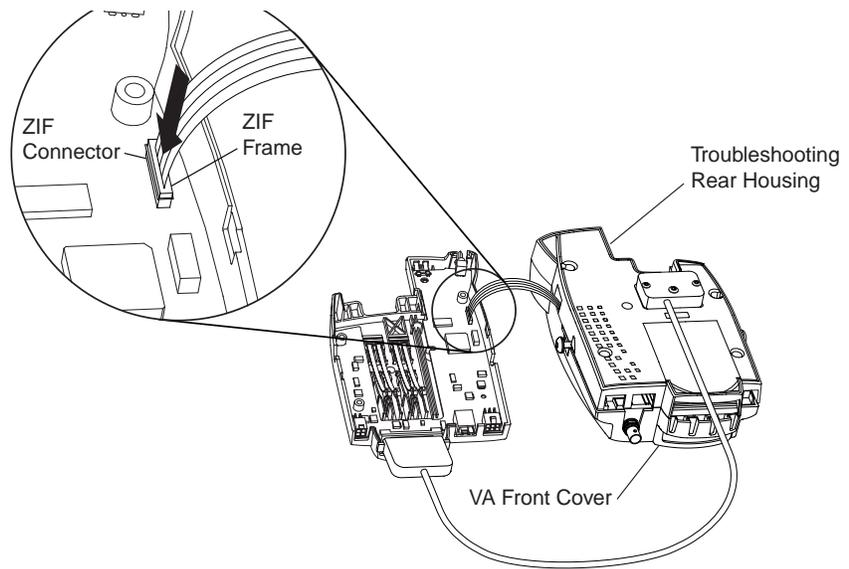

Figure 18 Securing the Flex Circuit Ribbon

Disassembly Instructions

1. Turn off the power supply to the unit. Turn off the radio.
2. Gently lift up the opening frame on the ZIF flex circuit connector (located on the PCB), and slide out the flex extender.
3. Unplug the DB25 connector.
4. Eject the radio from the XTVA.
5. Remove the troubleshooting rear housing. Place the screws to one side. **DO NOT LOSE THEM!**
6. Gently lift up the opening frame on the ZIF flex circuit connector (located on the flex extender) and slide out the VA flex circuit ribbon.
7. Remove power, microphone, and speaker cables from the back cover/PCB assembly.
8. Gently lift the PCB and replace PCB contacts underneath the charge contacts. Be sure to fit the locating features on the PCB contacts into their complementary features on the back housing. Lower the PCB in place.
9. Remove the front cover from the chassis.

Note: If you wish to continue disassembling the chassis go to the “Disassembly Procedure” (page 29) and start at step 8.

10. Lay the chassis upside down to the right of the back cover/PCB assembly. Carefully grasp the free end of VA flex circuit ribbon and insert it into the ZIF connector on the PCB. Secure the flex circuit ribbon end by pushing down on the ZIF connector frame.



While performing the next step, make sure not to pull on the flex circuit ribbon.

Caution

11. Rotate the chassis back into place on the back housing. Be careful not to pinch the flex circuit ribbon.
12. Continue with steps 25 through 29 of the Reassembly Procedure.

Microprocessor Initialization

Before an XTVA with a newly-programmed XTVA microprocessor can be used, the microprocessor must be “initialized.” This is also necessary if the microprocessor has “lost” its initialization. An XTVA with an uninitialized microprocessor will display the following sequence when it is powered-up:

	Charge LED	TX LED
1	Single orange flash	Single orange flash
2	Five red flashes	Steady orange
3	Off	Steady orange

To initialize the XTVA, do the following:

1. Remove the radio and the power source from the console.
2. On the console’s DB25 connector (J5), short pins 21 and 23 together; also, short pins 1 and 10 together. This could be done using the XTVA Programming Cable (P/N NTN9027_) or by soldering two jumpers onto a male DB25 connector.
3. Reconnect the power source to the console. Apply power to the console for at least 10 seconds (A+ and IGN on).
4. Remove the power source and jumpers from the console.
5. Reconnect the power source to the console and insert a radio into the console. The XTVA’s LEDs should display the following:

Charge LED	TX LED
Single orange flash	Single orange flash
Steady red	Off

Safe Handling of CMOS Integrated-Circuit Devices

Many of the integrated-circuit (IC) devices used in communications equipment are of the CMOS (Complementary Metal Oxide Semiconductor) type. Because of their high open-circuit impedance, CMOS ICs are vulnerable to damage from static charges. Everyone involved in handling, shipping, and servicing them must be extremely careful not to expose them to such damage.

CMOS ICs do have internal protection, but it is effective only against overvoltages in the hundreds of volts, such as those that could occur during normal operations. Overvoltages from static discharge can be in the thousands of volts.

When a CMOS IC is installed in a system, the circuit elements in the system distribute static charges and load the CMOS circuits. This decreases the vulnerability of the ICs to static discharge, but improper handling will probably cause static damage even when the ICs are so installed.

To avoid damaging CMOS ICs, take the following precautions when handling, shipping, and servicing them.

1. Before touching a circuit module, particularly after having moved around in the service area, touch both hands to a bare-metal, earth-grounded surface. This discharges any static charge you may have accumulated.

Note: Wear a conductive wrist strap (Motorola part number RSX-4015A) to minimize the buildup of static charges on your person while you are servicing CMOS equipment.



WARNING

When wearing a conductive wrist strap, be careful near sources of high voltage. By grounding you thoroughly, the wrist strap also increases the danger of lethal shock from accidental contact with such a source.

2. Whenever possible, avoid touching any electrically conductive parts of the circuit module with your hands.
3. Check the “Installation” and “Maintenance” sections of this manual and the notes on the schematic to find out whether or not you can insert or remove circuit modules with power applied to the unit, and act accordingly.
4. When servicing a circuit module, avoid carpeted areas, dry environments, and the wearing of static-generating clothing.
5. Be sure that all electrically powered test equipment is grounded. Attach the ground lead from the test equipment to the circuit module before connecting the test probe. Similarly, disconnect the test probe before removing the ground lead.
6. When you remove a circuit module from the system, lay it on a sheet of aluminum foil or other conductive surface connected to ground through 100,000 ohms of resistance.



WARNING

If the aluminum foil is connected directly to ground, you may get a shock if you touch it and another electrical circuit at the same time.

7. When soldering, be sure the soldering iron is grounded.
8. Before connecting jumpers, replacing circuit components, or touching CMOS pins (if this becomes necessary during the replacement of an integrated-circuit device), be sure to discharge any static buildup on your person (see step 1, above). Because you can have a voltage difference across your body, you should use only one hand if you must touch the board wiring or any of the pins on the CMOS device.
9. When replacing a CMOS integrated-circuit device, leave the device in its metal rail container or conductive foam until you are ready to insert it into the pronged circuit module.
10. Connect any low-impedance test equipment, such as a pulse generator, to CMOS device inputs after you have applied power to the CMOS circuitry. Similarly, disconnect such low-impedance equipment before turning off the power.

11. Wrap CMOS modules in conductive material when transporting them from one area to another, even within the same room. Use wrapping material similar to that in which replacement modules are wrapped when they arrive from the factory. (You can also use aluminum foil.) Never use nonconductive material for packaging these modules.

Soldering



Caution

Leadless component technology requires the use of specialized equipment and procedures for repair and servicing of the XTVA. If you are not totally familiar with leadless component repair techniques, it is strongly recommended that you either defer maintenance to qualified service personnel and service shops, or take the recommended video-taped component repair training program, MAV-PACK 3 (VID-952). This is of paramount importance as irreparable damage to the XTVA can result from service by unauthorized persons. Unauthorized attempts to remove or repair parts may void any existing warranties or extended performance agreements with the manufacturer.

Special care must be taken to be as certain as possible that a suspected component is actually at fault. This special care will eliminate unnecessary unsoldering and removal of parts, which could damage or weaken other components or the printed circuit board itself.

Rigid Circuit Boards

The XTVA uses bonded multi-layer printed circuit boards. Since the inner layers are not accessible, some special considerations are required when soldering and unsoldering components. The printed-through holes may interconnect multiple layers of the printed circuit. Therefore, care should be exercised to avoid pulling the plated circuit out of the hole. Closely examine your work for shorts due to solder bridges.

Flexible Circuits

The flexible circuits are made from a different material than the rigid boards, and different techniques must be used when soldering. Excessive prolonged heat on the flexible circuit can damage the material. Avoid excessive heat and excessive bending. For parts replacement, use the ST-1087 Temperature-Controlled Solder Station with a 600 or 700 degree tip, and use small diameter solder such as ST-633. The smaller-sized solder will melt faster and require less heat being applied to the circuit.

Parts Replacement and Substitution

When defective parts or components must be replaced, identical parts should be used. If the identical replacement part is not locally available, check the electrical and exploded view parts lists for the correct Motorola part number. Order the part from the nearest Motorola Communications Parts office as listed under "Replacement Parts Ordering" on the inside back cover of this manual.

If, for any reason, substitutions must be made, reinstall the exact replacement part as soon as possible to ensure optimum performance. The substituted part must have identical electrical characteristics and must have equal or higher voltage and current ratings.

Diagrams and Parts Lists



Note: The voltages in the tables below are typical values from an XTVA powered by a 13.8Vdc supply.

Table 5 Charger Section Voltage Measurements

SIGNAL	DC SW	5V REG		BATT R _C *	BATT R _T	BATT V	DAC OUT	REF RATE†	REF RATE†	BATT B+†
MEASURED AT	Q6	U7		VR2	VR3	U5	U3	Q13	R140	Q1, 2, 3
	@D15	1	3	C	C	44	5	C	@R66	C
RAPID	13.4	13.6	5	0.79	2.335	3.430	1.190	9.48	9.48	9.58
TRICKLE	13.4	13.6	5	0.79	2.335	3.447	0.213	8.66	8.66	8.67

* — Related to battery kit number NTN8294_
 † — Depends on battery charge status

Table 6 LED Circuitry Section Voltage Measurements

SIGNAL	CHARGE				MODE			
	RED		GREEN		TRANSMIT		RECEIVE	
MEASURED AT	U5	Q10	U5	Q11	U5	Q16	U5	Q16
	31	E	35	E	12	E	12	E
ON	5	4.3	5	4.3	5	4.3	5#	4.3#
DIM	5	2.9	5	2.9	5	2.9	5#	2.9#

— Pulsed signal from 0Vdc to the voltage shown at a 10% duty cycle

Table 7 DC Switch Section Voltage Measurements

SIGNAL	ENABLE	HOLD OFF	DRIVE	PASS	SUPPLY HOLD
MEASURED AT	Q31	Q6	Q19	Q4	U5
	D	D	C	S	9
ON	0	13.4	0.62	13,7	5
OFF	13.6	0 (RAD OUT)	13.70	<2	0
		13.4 (RAD IN)			

Conditions:

If either the vehicle or the radio is on while (AND) the radio is in the pocket or the μ P SUPPLY HOLD is asserted, the DC Switch will be ON.
 Refer to Table 7, "DC Switch Section Voltage Measurements," to diagnose a unit.

Note: For rev. "A" consoles, ignore the radio ON condition.

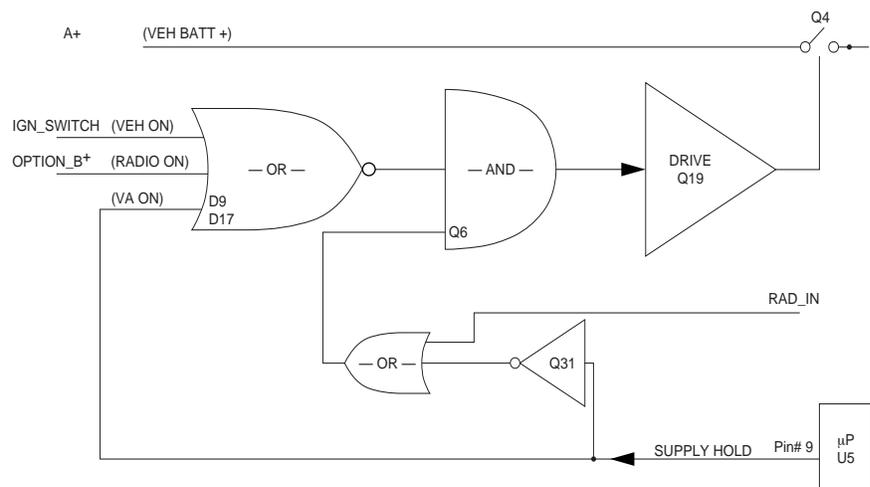
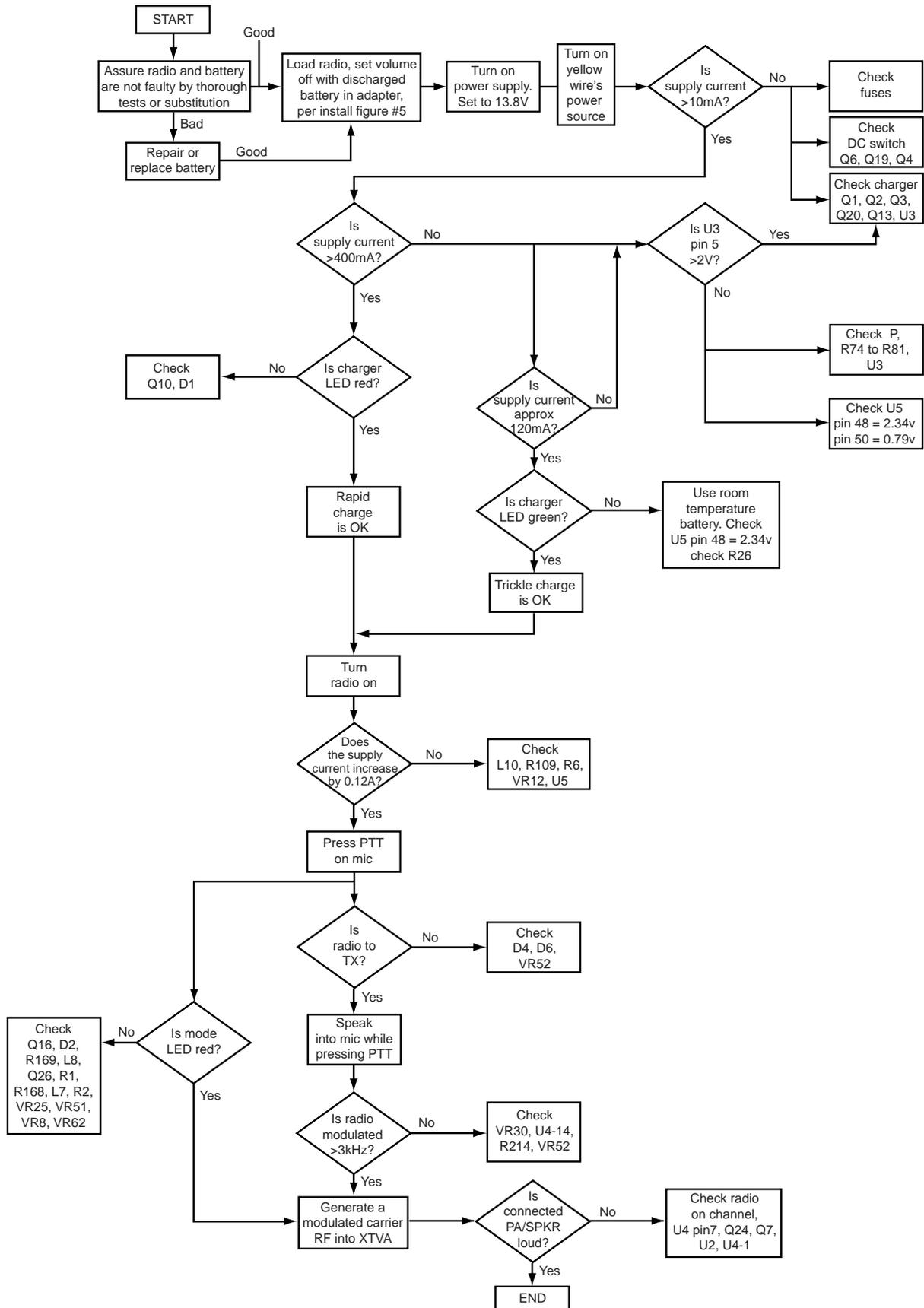

Figure 19 DC Switch Section Logic Diagram

Troubleshooting Flow Chart



0105956U22 XTVA Rev. Level A Printed Circuit Board
Electrical Parts List

ITEM	MOTOROLA PART NUMBER	DESCRIPTION
		CAPACITOR, Fixed; pF: unless otherwise stated
C1 thru 3	2113740F67	470
C5, 6	2113740F51	100
C7 thru 10	2113740F67	470
C11, thru 14	2311049A36	1.0µF±10%; 20V
C17	2113740F67	470
C18,	2311049C08	33µF±10%; 20V
C19	2311049A01	0.1µF±10%; 25V
C20, 21	2113740F67	470
C22 thru 24	2311049A01	0.1µF±10%; 25V
C25	2113740F67	470
C26	2311049A01	0.1µF±10%; 25V
C27	2113740F67	470
C28, 29	2311049A01	0.1µF±10%; 25V
C30 thru 33	2113740F67	470
C34, 35	2311049A01	0.1µF±10%; 25V
C37 thru 39	2113740F67	470
C40	2311049A01	0.1µF±10%; 25V
C41	2113740F67	470
C42 thru 45	2113740F36	24
C46, 47	2113740F67	470
C50 thru 52	2113740F67	470
C54, 55	2113740F67	470
C58 thru 67	2113740F67	470
C68	2113741F27	1200
C69, 70	2113740F67	470
C71,	2311049A36	1.0µF±10%; 20V
C72	2311049C08	33µF±10%; 20V
C73,	2311049A36	1.0µF±10%; 20V
C75	2311049A36	1.0µF±10%; 20V
C77 thru 82	2311049A36	1.0µF±10%; 20V
C83	2311049C08	33µF±10%; 20V
C85, 86	2311049J11	4.7µF±10%; 16V
C87	2113741F27	1200
C88	2113741F09	220
C89	2311049C08	33µF±10%; 20V
C90, 91	2113740F36	24
C93, 94,	2311049A01	0.1µF±10%; 25V
C95	2113740F67	470
C96	2113741F27	1200
C97, 98	2113740F67	470
C99	2311049A01	0.1µF±10%; 25V
C100, 101	2113740F36	24
C102 thru 107	2113740F67	470
C109 thru 111	2113740F67	470
C112	2311049A01	0.1µF±10%; 25V
C113	2113740F67	470
C114,	2311049A01	0.1µF±10%; 25V
C115	2113740F67	470
C167, 168	2113740F67	470
C170	2311049J11	4.7µF±10%; 16V
C171 thru 176	2113740F67	470
C202 thru 205	2113740F67	470
C206	2311049A36	1.0µF±10%; 20V
C208,	2311049C08	33µF±10%; 20V
C209,	2311049A01	0.1µF±10%; 25V
C210	2311049A05	0.47µF±10%; 25V
C212	2311049A36	1.0µF±10%; 20V
C214, 215,	2113740F67	470
C217	2113740F67	470
C218	2311049A36	1.0µF±10%; 20V

ITEM	MOTOROLA PART NUMBER	DESCRIPTION
D1, 2	4885949B01	DIODE: See Note 1
D4	4805218N57	LED
D6	4805129M05	Dual Common-Cathode Schottky
D9 thru 13	4805218N57	Dual Common-Cathode Schottky
D14 thru 16	4805129M05	Dual Common-Cathode Schottky
D17	4805218N57	Dual Common-Cathode Schottky
J1	0985123C02	JACK: SOCKET, Molex, 6-Pin
J2	0985170C01	SOCKET, Molex, 4-Pin
J4	0905763Z01	SOCKET, RJ11 Style
J5	0960113D03	D-SU, 25-Pin
J6	0905257V03	SOCKET, ZIF, 18-Pin
L1 thru 14	2462575A14	COIL, RF: 270nH
Q1 thru 3	4813822A10	TRANSISTOR: See Note 1. PNP, DPAK
Q4, 5	4813821A14	MOSFET, P-Channel
Q6, 7	4802393L01	MOSFET, N-Channel
Q9	4805128M40	PNP, Gen Purpose
Q10 thru 13	4805128M12	NPN, Gen Purpose
Q15	4802393L01	MOSFET, N-Channel
Q16	4813824A10	NPN, Gen Purpose
Q17 thru 19	4805128M19	NPN, Darlington
Q20 thru 22	4813824A10	NPN, Gen Purpose
Q23 thru 26	4802393L01	MOSFET, N-Channel
Q27	4805128M12	NPN, Gen Purpose
Q28	4805128M40	PNP, Gen Purpose
Q29, 30	4805128M12	NPN, Gen Purpose
R1	0662057P10	RESISTOR: Ohms ±5%; 1/8W unless otherwise stated 10k±1%;1/10W
R2 thru 4	0662057A97	100kΩ,5%,1/10W
R6, 7	0662057A97	100kΩ,5%,1/10W
R8	0662057A33	220;1/10W
R9	0662057P10	10k±1%;1/10W
R11 thru R14	0662057A97	100kΩ,5%,1/10W
R15	0662057P10	10k±1%;1/10W
R16	0662057B06	220k;1/10W
R17, 18	0662057P10	10k±1%;1/10W
R20 thru 26	0662057P10	10k±1%;1/10W
R27	0662057P20	20k±1%
R28	0662057P51	51k±1%;1/10W
R29 thru 31	0662057P10	10k±1%;1/10W
R32	0662057B14	470k;1/10W
R33	0662057P10	10k±1%;1/10W
R35 thru 38	0662057P10	10k±1%;1/10W
R40	0662057P10	10k±1%;1/10W
R41	0662057A33	220;1/10W
R42 thru 44	0662057P10	10k±1%;1/10W
R45	0662057A97	100kΩ,5%,1/10W
R47	0662057P10	10k±1%;1/10W
R48	0662057Z42	33k±1%;1/10W
R49	0662057P51	51k±1%;1/10W
R52 thru 55	0662057A49	1k;1/10W
R57	0662057A33	220;1/10W
R58	0662057B47	0Ω±1/20%
R59	0662057A49	1k;1/10W
R60 thru 67	0662057P10	10k±1%;1/10W
R68 thru 71	0660076A32	200
R72 thru 81	0662057P20	20k±1%
R83	0662057B14	470k;1/10W
R84	0662057A17	47;1/10W

ITEM	MOTOROLA PART NUMBER	DESCRIPTION
R85	0662057A33	220;1/10W
R86, 87	0662057A29	150Ω,5%,1/10W
R88 thru 90	0662057A33	220;1/10W
R91	0662057A29	150Ω,5%,1/10W
R92, 93	0662057A33	220;1/10W
R94	0660076E45	680±1%
R95 thru 97	0662057A45	680;1/10W
R98, 99	0662057A43	560;1/10W
R100	0660076A56	2k
R103	0660076A56	2k
R106	0660076A56	2k
R109, 110	0662057P20	20k±1%
R111	0662057Z42	33k±1%;1/10W
R112	0662057P10	10k±1%;1/10W
R113	0662057A56	2k;1/10W
R114 thru 117	0662057A25	100;1/10W
R118	0662057A45	680;1/10W
R120 thru 122	0662057Z42	33k±1%;1/10W
R123	0662057A49	1k;1/10W
R126	0662057B06	220k;1/10W
R128	0662057A97	100kΩ,5%,1/10W
R131	0662057B22	1M;1/10W
R133, 134	0662057A97	100kΩ,5%,1/10W
R135	0660076E17	47±1%
R136	0662057A56	2k;1/10W
R137 thru 139	0680195M62	1.0;1/2W
R140	0605846S01	0.2±1%
R141	1886266A01	50k, Potentiometer
R144, 145	0662057A97	100kΩ,5%,1/10W
R164	0662057A29	150Ω,5%,1/10W
R165	0662057A97	100kΩ,5%,1/10W
R166	0662057B06	220k;1/10W
R167	0662057P10	10k±1%;1/10W
R168, 169	0662057A17	47;1/10W
R180	0662057P10	10k±1%;1/10W
R200	0662057P20	20k±1%
R203	0662057B06	220k;1/10W
R204	0662057P10	10k±1%;1/10W
R205	0662057B47	0Ω±1/20%
R208	0662057A97	100kΩ,5%,1/10W
R209 thru 212	0662057A43	560;1/10W
R214, 215	0662057P10	10k±1%;1/10W
R216	0662057B06	220k;1/10W
R217	0662057B47	0Ω±1/20%
R219	0662057A25	100;1/10W
R220	0662057A97	100kΩ,5%,1/10W
R221	0662057P10	10k±1%;1/10W
R222	0662057A25	100;1/10W
R223, 224	0662057B47	0Ω±1/20%
R226	0662057B47	0Ω±1/20%
R230	0662057B47	0Ω±1/20%
R330	0662057B06	220k;1/10W
R331, 332	0662057P10	10k±1%;1/10W
R335	0662057P10	10k±1%;1/10W
R336	0662057A43	560;1/10W
R341 thru 343	0662057P10	10k±1%;1/10W
R344	0662057P20	20k±1%
R346	0662057A97	100kΩ,5%,1/10W
R347	0662057A49	1k;1/10W
R348	0660076A56	2k
R349, 350	0662057P10	10k±1%;1/10W
U1	5105469E65	INTEGRATED CIRCUIT Regulator, 5v
U2	5113806A20	MUX, 3 of 2 Channel
U3, 4	5102198J28	Op Amp, Quad

ITEM	MOTOROLA PART NUMBER	DESCRIPTION
U5	5113802A03	Microprocessor, 68HC11E9
U6	5113815A02	Sensor, Undervoltage, 5v
U7	5113816A07	Regulator, Programmable
U8	5143206U01	Level Shifter, RS232
VR2, 3	4880140L07	DIODE: See Note 1. Zener, 5.6V
VR8	4805656W08	Zener, Quad 5.6V
VR11, 12	4880140L07	Zener, 5.6V
VR15	4880140L07	Zener, 5.6V
VR16	4813830A22	Zener, 9.1V
VR17	4880140L07	Zener, 5.6V
VR18	4813830A22	Zener, 9.1V
VR19 thru 21	4880140L17	Zener, 12V
VR25	4805656W08	Zener, Quad 5.6V
VR29	4802197J32	Zener, Transorber
VR30	4813830A22	Zener, 9.1V
VR31	4805656W08	Zener, Quad 5.6V
VR33, 34	4805656W10	Zener, Dual 15V ca
VR35	4813830A40	Zener, 33V
VR36 thru 43	4805656W10	Zener, Dual 15V ca
VR51, 52	4805656W08	Zener, Quad 5.6V
VR62	4805656W08	Zener, Quad 5.6V
VR63 thru 65	4880140L17	Zener, 12V
VR67 thru 69	4880140L17	Zener, 12V
VR70	4802197J32	Zener, Transorber
Y1	4860875A01	CRYSTAL: See Note 2. 7.3728MHz
	8486144A01	MISCELLANEOUS: Board, PC

Notes:

- For optimum performance, order replacement diodes, transistors, and circuit modules by Motorola part number only.
- When ordering crystals, specify carrier frequency, crystal frequency, crystal type number, and Motorola part number.
- Part value notations:

p=10 ⁻¹²	m=10 ⁻³
n=10 ⁻⁹	k=10 ³
µ=10 ⁻⁶	M=10 ⁶

VIEWED FROM SIDE 1

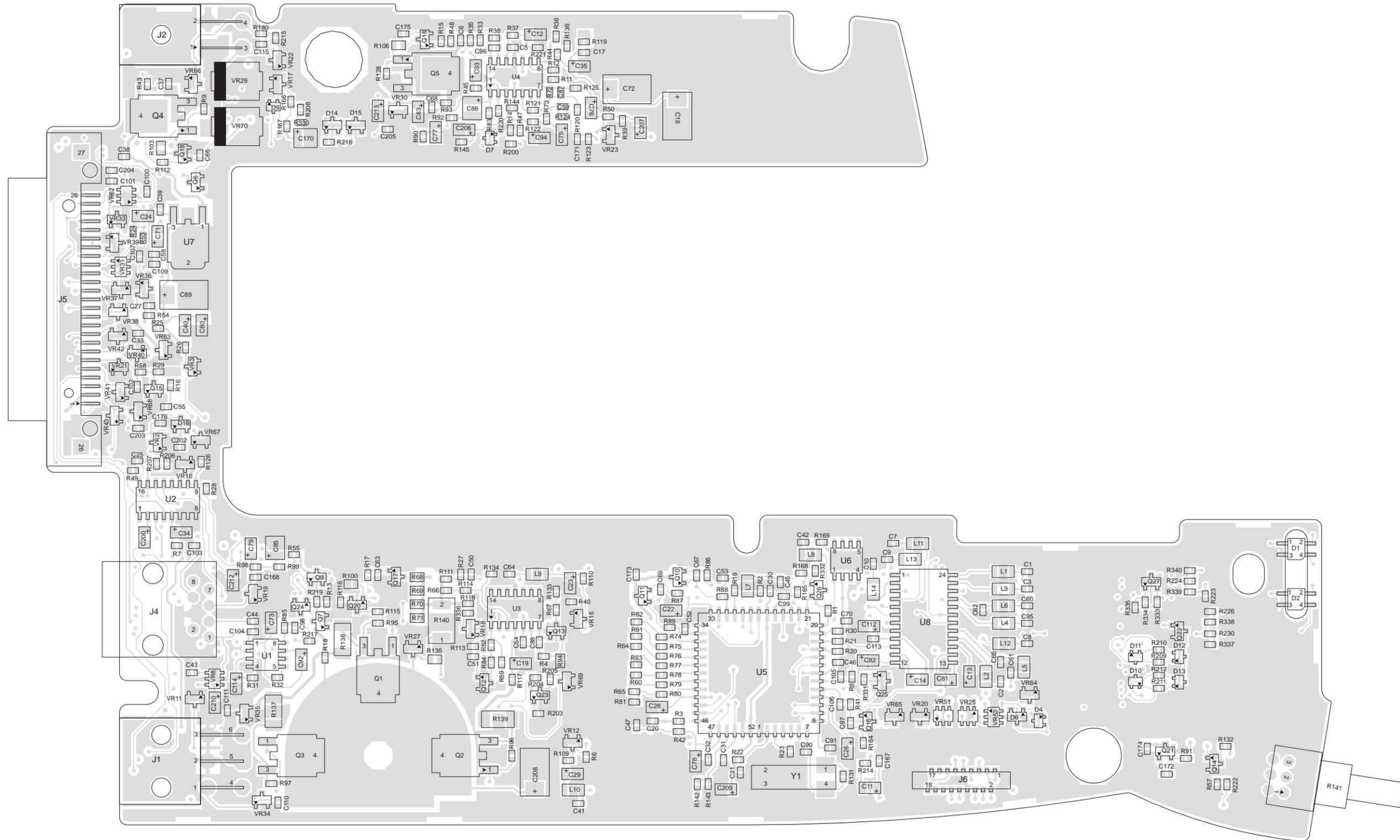

MAEPF-26683-O

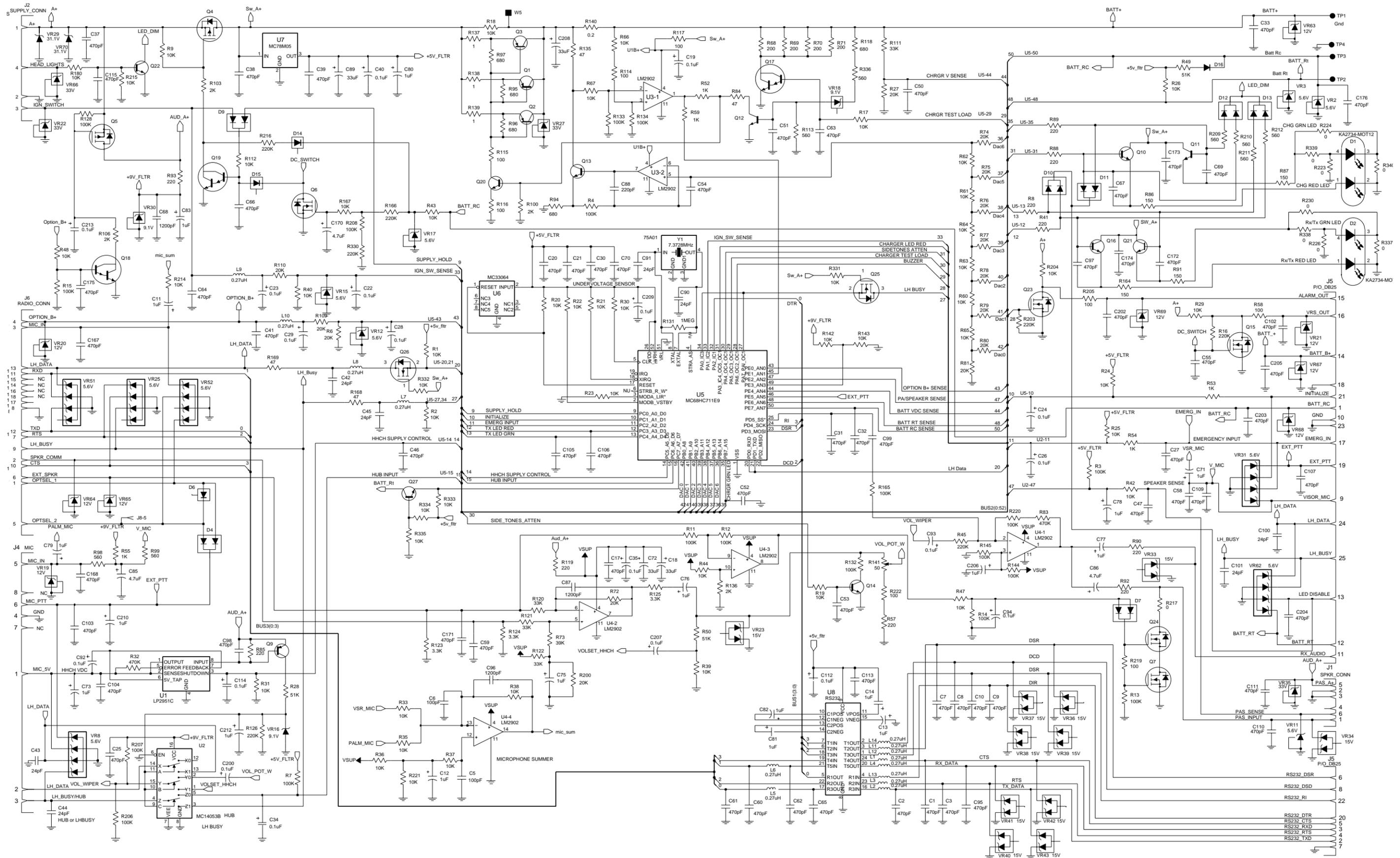

ASTRO XTS Vehicular Adapter Console Revision Level A Printed Circuit Board Schematic Diagram 49

Notes

Notes

0105956U22 XTVA Rev. Level B Printed Circuit Board
Electrical Parts List

ITEM	MOTOROLA PART NUMBER	DESCRIPTION
		CAPACITOR, Fixed; pF: unless otherwise stated
C1 thru 3	2113740F09	220
C5 thru 10	2113740F09	220
C11, thru 14	2311049A36	1.0µF±10%; 20V
C17	2113740F09	220
C18,	2311049C08	33µF±10%; 20V
C19	2311049A01	0.1µF±10%; 25V
C20, 21	2113740F67	470
C22 thru 24	2311049A01	0.1µF±10%; 25V
C25	2113740F67	470
C26	2311049A01	0.1µF±10%; 25V
C27	2113740F09	220
C28, 29	2311049A01	0.1µF±10%; 25V
C30	2113740F67	470
C31 thru 33	2113740F09	220
C34, 35	2311049A01	0.1µF±10%; 25V
C37	2113740F09	220
C38, 39	2113740F67	470
C40	2311049A01	0.1µF±10%; 25V
C41	2113740F09	220
C42 thru 45	2113740F36	24
C46	2113740F67	470
C47	2113740F09	220
C50 thru 52	2113740F67	470
C54, 55	2113740F67	470
C58, 59	2113740F09	220
C60, 61	2113740F67	470
C62	2113740F09	220
C631	2113740F67	470
C64, 65	2113740F09	220
C66, 67	2113740F67	470
C68	2113741F27	1200
C69, 70	2113740F67	470
C71,	2311049A36	1.0µF±10%; 20V
C72	2311049C08	33µF±10%; 20V
C73,	2311049A36	1.0µF±10%; 20V
C75	2311049A36	1.0µF±10%; 20V
C77 thru 82	2311049A36	1.0µF±10%; 20V
C83	2311049C08	33µF±10%; 20V
C85, 86	2311049J11	4.7µF±10% ;16V
C87	2113741F27	1200
C88	2113741F09	220
C89	2311049C08	33µF±10%; 20V
C90, 91	2113740F36	24
C93,	2311049A01	0.1µF±10%; 25V
C94	2311049A36	1.0µF±10%; 20V
C95	2113740F09	220
C96	2113741F27	1200
C97, 98	2113740F67	470
C99	2311049A01	0.1µF±10%; 25V
C100, 101	2113740F36	24
C102 thru 104	2113740F09	220
C105, 106	2113740F67	470
C107	2113740F09	220
C109 thru 111	2113740F09	220
C112	2311049A01	0.1µF±10%; 25V
C113	2113740F09	220
C114,	2311049A01	0.1µF±10%; 25V
C115	2113740F09	220
C167, 168	2113740F09	220
C170	2311049J11	4.7µF±10% ;16V
C171	2113740F09	220
C172 thru 174	2113740F67	470
C175, 176	2113740F09	220

ITEM	MOTOROLA PART NUMBER	DESCRIPTION
C202 thru 205	2113740F09	220
C206	2311049A36	1.0µF±10%; 20V
C208,	2311049C08	33µF±10%; 20V
C209,	2311049A01	0.1µF±10%; 25V
C210	2311049A05	0.47µF±10%; 25V
C212	2311049A36	1.0µF±10%; 20V
C213,	2311049A01	0.1µF±10%; 25V
C214, 215,	2113740F67	470
C217	2113740F67	470
C219 thru 224	2113740F09	220
D1, 2	4885949B01	DIODE: See Note 1 LED
D4	4805218N57	Dual Common-Cathode
D6	4805129M05	Schottky
D9 thru 13	4805218N57	Dual Common-Cathode
D15, 16	4805129M05	Schottky
D17	4805218N57	Dual Common-Cathode
D19 thru 22	4805218N57	Dual Common-Cathode
J1	0985123C02	JACK: SOCKET, Molex, 6-Pin
J2	0985170C01	SOCKET, Molex, 4-Pin
J4	0905763Z01	SOCKET, RJ11 Style
J5	0960113D03	D-SU, 25-Pin
J6	0905257V03	SOCKET, ZIF, 18-Pin
L1 thru 14	2462575A14	COIL, RF: 270nH
Q1 thru 3	4813822A10	TRANSISTOR: See Note 1. PNP, DPAK
Q4, 5	4813821A32	MOSFET, P-Channel
Q6, 7	4813823A07	MOSFET, N-Channel
Q9	4813824A21	PNP, Gen Purpose
Q10 thru 13	4813824A10	NPN, Gen Purpose
Q15	4813823A07	MOSFET, N-Channel
Q16	4813824A10	NPN, Gen Purpose
Q17	4805128M19	NPN, Darlington
Q18	4813823A07	MOSFET, N-Channel
Q19	4805128M19	NPN, Darlington
Q20 thru 22	4813824A10	NPN, Gen Purpose
Q23 thru 26	4813823A07	MOSFET, N-Channel
Q27	4813824A10	NPN, Gen Purpose
Q29	4813824A10	NPN, Gen Purpose
Q30	4813824A21	PNP, Gen Purpose
Q31	4813823A07	MOSFET, N-Channel
Q34, 35	4813824A21	PNP, Gen Purpose
Q36	4813823A07	MOSFET, N-Channel
R1	0662057P10	RESISTOR: Ohms ±5%; 1/8W unless otherwise stated 10k±1%;1/10W
R2 thru 4	0662057A97	100kΩ,5%,1/10W
R6, 7	0662057A97	100kΩ,5%,1/10W
R8	0662057A33	220;1/10W
R9	0662057P10	10k±1%;1/10W
R11 thru R14	0662057A97	100kΩ,5%,1/10W
R16	0662057B06	220k;1/10W
R17, 18	0662057P10	10k±1%;1/10W
R20 thru 26	0662057P10	10k±1%;1/10W
R27	0662057P20	20k±1%
R28	0662057P51	51k±1%;1/10W
R29 thru 31	0662057P10	10k±1%;1/10W
R32	0662057B14	470k;1/10W
R33	0662057P10	10k±1%;1/10W
R35 thru 38	0662057P10	10k±1%;1/10W
R40	0662057P10	10k±1%;1/10W

ITEM	MOTOROLA PART NUMBER	DESCRIPTION
R41	0662057A33	220;1/10W
R42 thru 44	0662057P10	10k±1%;1/10W
R45	0662057A97	100kΩ,5%,1/10W
R47	0662057P10	10k±1%;1/10W
R48	0662057A49	1k;1/10W
R49	0662057P51	51k±1%;1/10W
R52 thru 55	0662057A49	1k;1/10W
R57	0662057A33	220;1/10W
R58	0662057B47	0Ω±1/20%
R59	0662057A49	1k;1/10W
R60 thru 67	0662057P10	10k±1%;1/10W
R68 thru 71	0660076A32	200
R72 thru 81	0662057P20	20k±1%
R83	0662057P20	20k±1%
R84	0662057A17	47;1/10W
R85	0662057A33	220;1/10W
R86, 87	0662057A29	150Ω,5%,1/10W
R88 thru 90	0662057A33	220;1/10W
R91	0662057A29	150Ω,5%,1/10W
R92, 93	0662057A33	220;1/10W
R94	0660076E45	680±1%
R95 thru 97	0662057A45	680;1/10W
R98, 99	0662057A43	560;1/10W
R100	0660076A56	2k
R103	0660076A56	2k
R106	0660076A56	2k
R109, 110	0662057P20	20k±1%
R111	0662057Z42	33k±1%;1/10W
R112	0662057P10	10k±1%;1/10W
R113	0662057A56	2k;1/10W
R114 thru 117	0662057A25	100;1/10W
R118	0662057A45	680;1/10W
R119	0662057A33	220;1/10W
R120 thru 122	0662057Z42	33k±1%;1/10W
R123	0662057A56	2k;1/10W
R126	0662057B06	220k;1/10W
R128	0662057A97	100kΩ,5%,1/10W
R131	0662057B22	1M;1/10W
R133, 134	0662057A97	100kΩ,5%,1/10W
R135	0660076E17	47±1%
R136	0662057A56	2k;1/10W
R137 thru 139	0680195M62	1.0;1/2W
R140	0605846S01	0.2±1%
R141	1886266A01	50k, Potentiometer
R144, 145	0662057A97	100kΩ,5%,1/10W
R164	0662057A29	150Ω,5%,1/10W
R165	0662057A97	100kΩ,5%,1/10W
R166	0662057B06	220k;1/10W
R167	0662057P10	10k±1%;1/10W
R168, 169	0662057A17	47;1/10W
R180	0662057P10	10k±1%;1/10W
R200	0662057P20	20k±1%
R203	0662057B06	220k;1/10W
R204	0662057P10	10k±1%;1/10W
R208	0662057A97	100kΩ,5%,1/10W
R209 thru 212	0662057A43	560;1/10W
R214, 215	0662057P10	10k±1%;1/10W
R216	0662057B06	220k;1/10W
R217	0662057B47	0Ω±1/20%
R219	0662057A25	100;1/10W
R220, 221	0662057P10	10k±1%;1/10W
R222	0662057A25	100;1/10W
R223, 224	0662057B47	0Ω±1/20%
R226	0662057B47	0Ω±1/20%
R230	0662057B47	0Ω±1/20%
R330	0662057B06	220k;1/10W
R331, 332	0662057P10	10k±1%;1/10W
R335	0662057P10	10k±1%;1/10W

ITEM	MOTOROLA PART NUMBER	DESCRIPTION
R336	0662057A43	560;1/10W
R337 thru 340	0662057B47	0Ω±1/20%
R341	0662057P10	10k±1%;1/10W
R343	0662057P10	10k±1%;1/10W
R346	0662057A97	100kΩ,5%,1/10W
R347	0662057A49	1k;1/10W
R348	0660076A56	2k
R349 thru 351	0662057P10	10k±1%;1/10W
R352 thru 354	0662057A97	100kΩ,5%,1/10W
R355	0662057A56	2k;1/10W
R358, 359	0660079U13	3.3±1%
R360	0662057A43	560;1/10W
R361	0662057A17	47;1/10W
R362	0662057A97	100kΩ,5%,1/10W
U1	5105469E65	INTEGRATED CIRCUIT MODULE: See Note 1. Regulator, 5v
U2	5113806A20	MUX, 3 of 2 Channel
U3, 4	5102198J28	Op Amp, Quad
U5	5113802A03	Microprocessor, 68HC11E9
U6	5113815A02	Sensor, Undervoltage, 5v
U7	5113816A07	Regulator, Programmable
U8	5143206U01	Level Shifter, RS232
VR2, 3	4880140L07	DIODE: See Note 1. Zener, 5.6V
VR8	4805656W08	Zener, Quad 5.6V
VR11, 12	4880140L07	Zener, 5.6V
VR15	4880140L07	Zener, 5.6V
VR16	4813830A22	Zener, 9.1V
VR17	4880140L07	Zener, 5.6V
VR18	4813830A22	Zener, 9.1V
VR19, 20	4880140L17	Zener, 12V
VR21, 22	4813830A40	Zener, 33V
VR25	4805656W08	Zener, Quad 5.6V
VR27	4813830A40	Zener, 33V
VR29	4802197J32	Zener, Transorber
VR30	4813830A22	Zener, 9.1V
VR31	4805656W08	Zener, Quad 5.6V
VR33, 34	4805656W10	Zener, Dual 15V ca
VR35	4813830A40	Zener, 33V
VR36 thru 43	4805656W10	Zener, Dual 15V ca
VR51, 52	4805656W08	Zener, Quad 5.6V
VR62	4805656W08	Zener, Quad 5.6V
VR63 thru 65	4880140L17	Zener, 12V
VR66	4813830A40	Zener, 33V
VR67, 68	4880140L17	Zener, 12V
VR69	4813830A40	Zener, 33V
VR70	4802197J32	Zener, Transorber
Y1	4860875A01	CRYSTAL: See Note 2. 7.3728MHz
	8486144A02	MISCELLANEOUS: Board, PC

Notes:

- For optimum performance, order replacement diodes, transistors, and circuit modules by Motorola part number only.
- When ordering crystals, specify carrier frequency, crystal frequency, crystal type number, and Motorola part number.
- Part value notations:

p=10 ⁻¹²	m=10 ⁻³
n=10 ⁻⁹	k=10 ³
µ=10 ⁻⁶	M=10 ⁶

VIEWED FROM SIDE 1

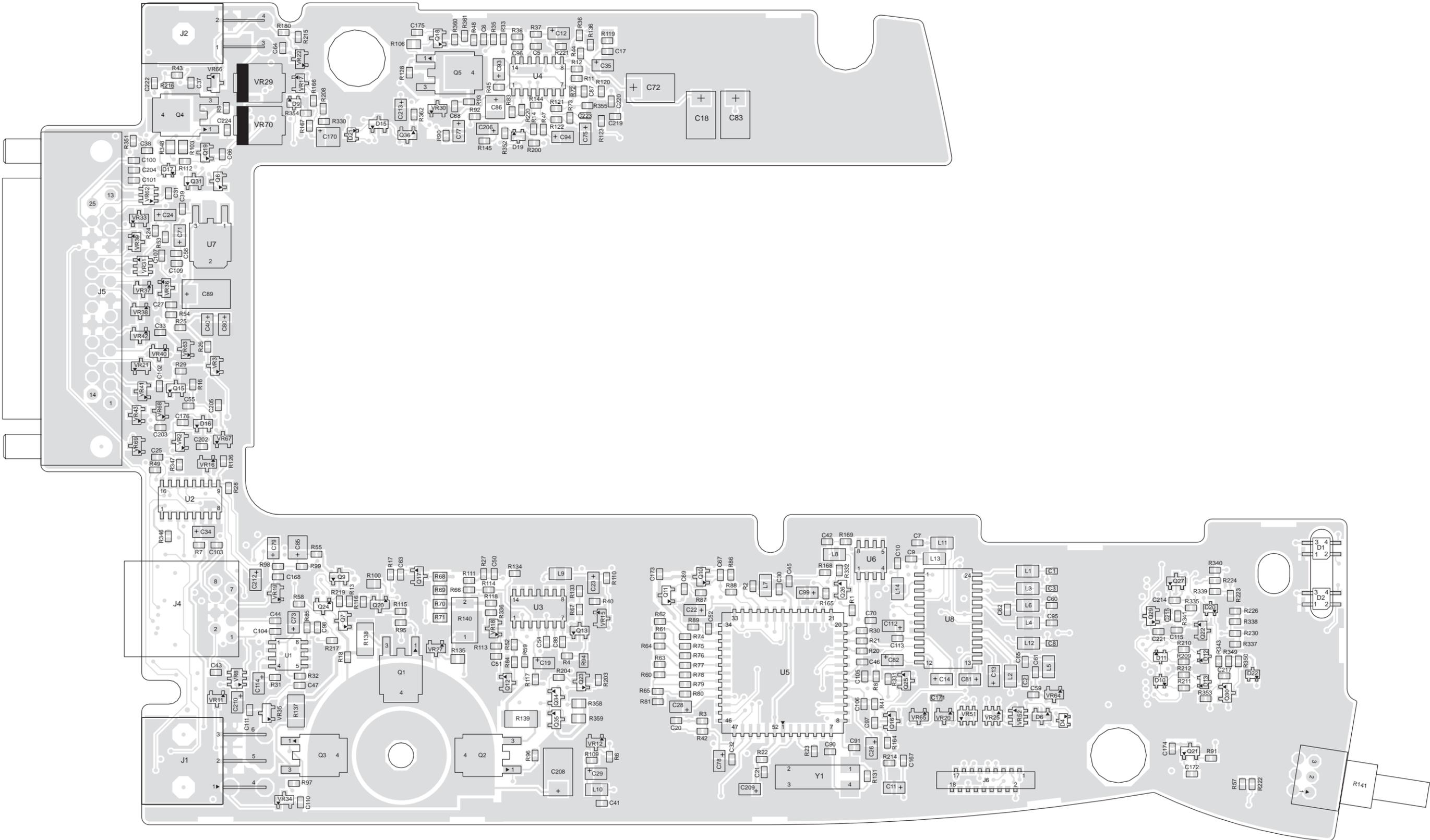

MAEPF-26750-O

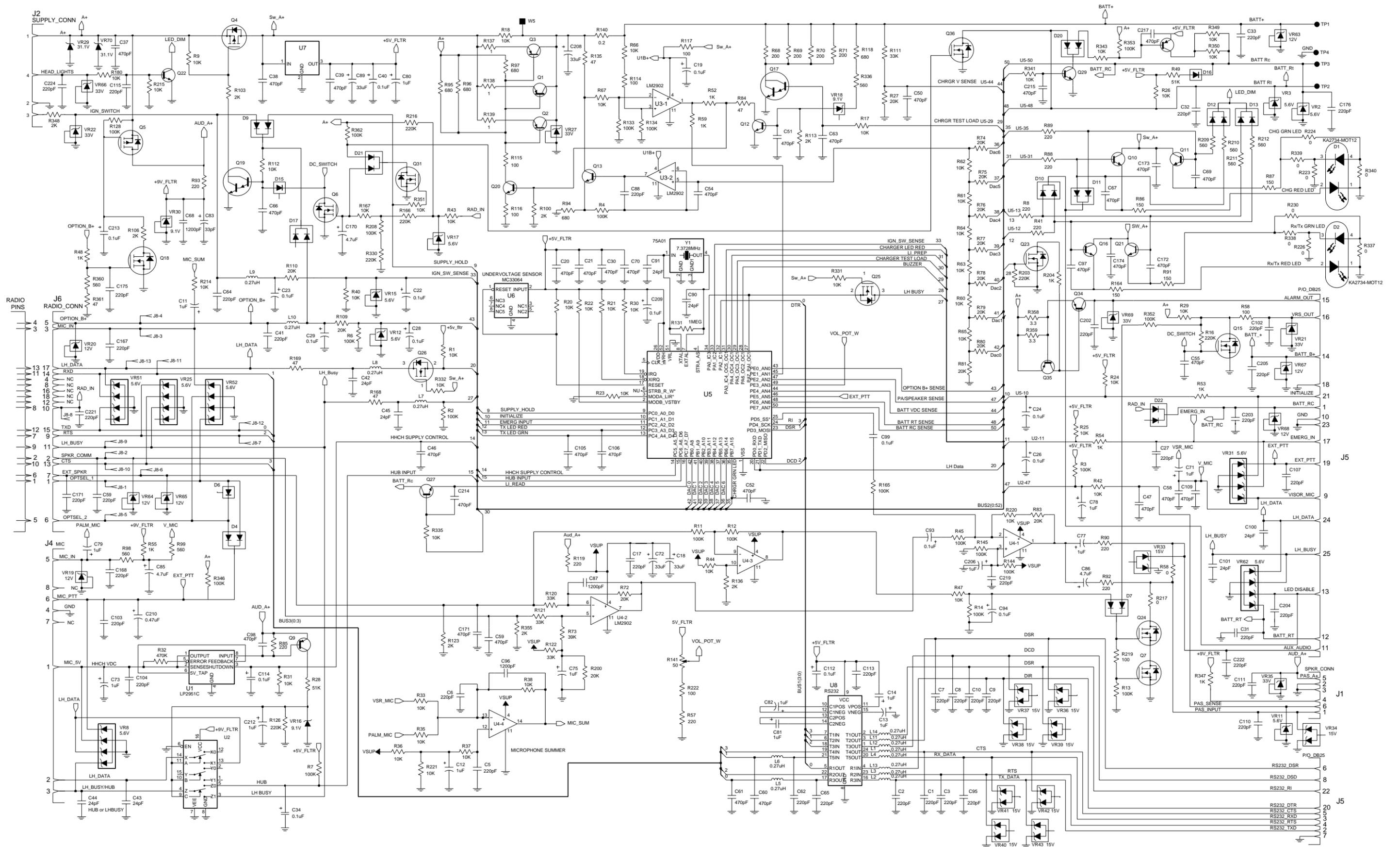

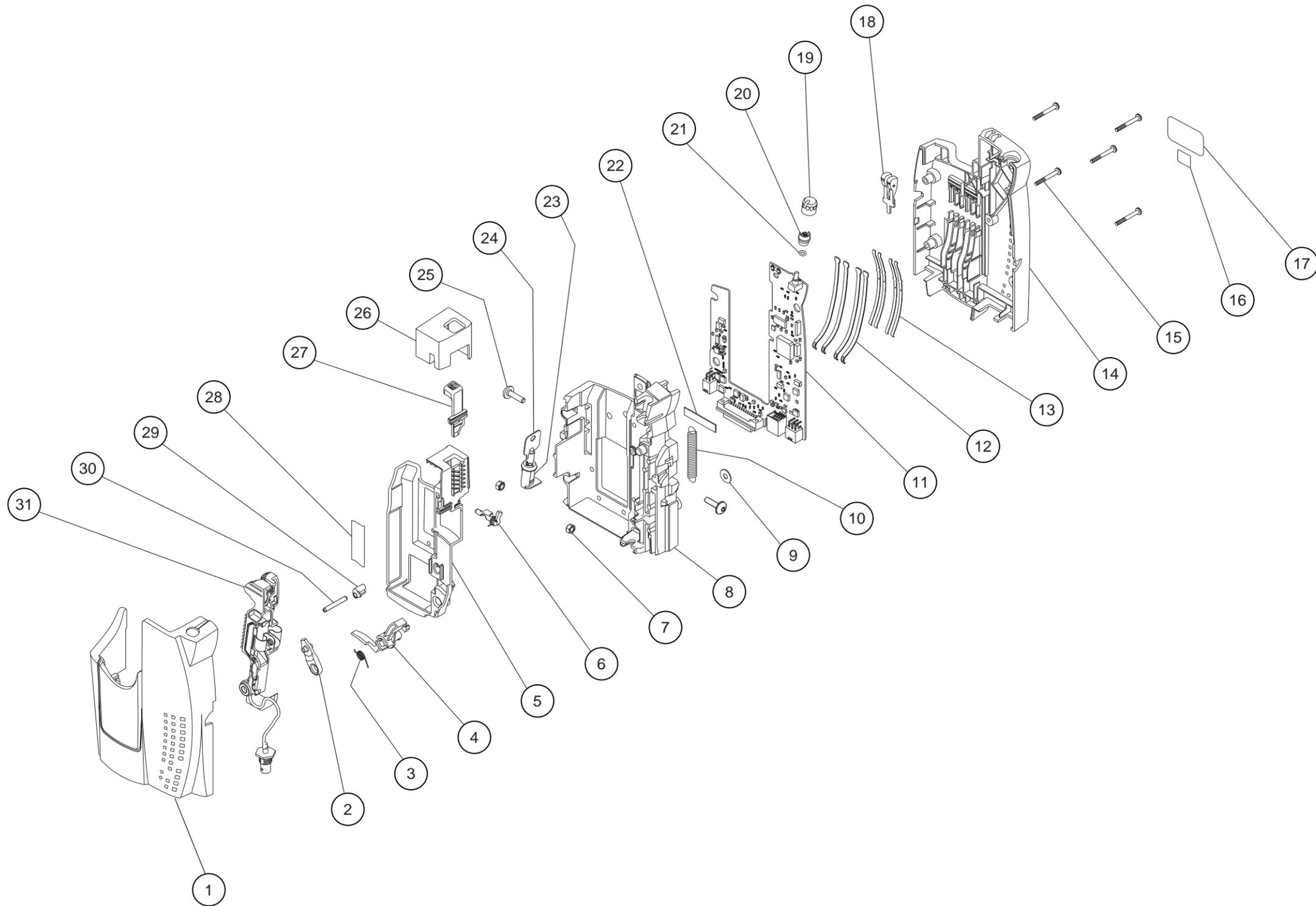

**ASTRO XTVA Console
Exploded View Parts List**

ITEM NO.	MOTOROLA PART NUMBER	DESCRIPTION
1	1585760A04 or 1585760A05	HOUSING, Front (Closed) HOUSING, Front (Open)
2	4586149A01	LINK (part of item 31)
3	4185768A01	SPRING, Kicker
4	4585767A01	KICKER
5	1585762A03	HOUSING, Pocket (includes item 28)
6	0105956V42	ASSEMBLY, Latch
7	0286146A01	NUT, Trunion (2 req'd)
8	2785761A02	CHASSIS (includes item 9)
9	7586151A01	PAD, Thermal (part of item 8)
10	4185770A01	SPRING, Eject
11	0105956U22	KIT, PCB Assembly (for Rev. B and higher consoles only)
12	3985878B01	CONTACT, Charge (4 req'd)
13	3985879B01	CONTACT, PCB (4 req'd)
14	1585822A03	HOUSING, Back
15	0310908A96	SCREW, Back Cover (5 req'd)
16	5405247W06	LABEL, Date Code
17	3305409X32	LABEL, Nameplate
18	6186158A01	LIGHTPIPE
19	3605371Z01	KNOB, Volume
20	4305372Z01	INSERT, Knob
21	3205082E98	O-RING
22	1485923B02	INSULATOR
23	5586156A01	LOCK (includes item 24)
24	5586156A02	KEY (part of item 23)
25	0385881B01	SCREW, Button Head (2 req'd)
26	1585763A02	HOUSING, Pocket Lid
27	3886293A01	BUTTON, Eject
28	3305455U08	LABEL, Caution (part of item 5)
29	4386148A01	BUSHING, Universal
30	4786150A01	PIN
31	0105956V68	ASSEMBLY, Universal Coax (includes item 2)
---	3005297Y03	CABLE, Power (Not Shown)

REPLACEMENT PARTS ORDERING

ORDERING INFORMATION

When ordering replacement parts or equipment information, the complete identification number should be included. This applies to all components, kits, and chassis. If the component part number is not known, the order should include the number of the chassis or kit of which it is a part, and sufficient description of the desired component to identify it.

Crystal and channel element orders should specify the crystal or channel element type number, crystal and carrier frequency, and the model number in which the part is used.

MAIL ORDERS

Send written orders to the following addresses:

Replacement Parts/
Test Equipment/Manuals/
Crystal Service Items:

Motorola Inc.
United States and Canada
Aftermarket Products Division
Attention: Order Processing
1313 E. Algonquin Road
Schaumburg, IL 60196

Federal Government Orders:

Motorola Inc.
United States and Canada
Aftermarket Products Division
Attention: Order Processing
7230 Parkway Drive
Landover, MD 21076

International Orders:

Motorola Inc.
United States and Canada
Aftermarket Products Division
Attention: International Order
Processing
1313 E. Algonquin Road
Schaumburg, IL 60196

TELEPHONE ORDERS

United States and Canada Accessories and Aftermarket Division:
Call: 1-800-422-4210
1-800-826-1913 (For Federal Government Orders)
1-847-538-8023 (International Orders)

Servicers Training (VHS Video Tapes):
Call: 847-576-2828

FAX ORDERS

United States and Canada Accessories and Aftermarket Division:
FAX: 847-538-8198 (Domestic)
847-576-3023 (International)
Parts ID: 847-538-8194

Federal Government Orders:
FAX: 410-712-4991
International: 410-712-6200

PARTS CUSTOMER SERVICE

United States and Canada Aftermarket Products
Division:
Call: 1-800-422-4210
Parts Identification:
Call: 847-538-0021

PRODUCT CUSTOMER SERVICE

Customer Response Center
(Sales and Service Assistance):
Call: 1-800-247-2346
FAX: 1-800-232-9272



68P81088C78-O

Motorola
8000 West Sunrise Boulevard
Fort Lauderdale, Florida 33322

Introduction

This manual revision details changes to the ASTRO XTS / DIMETRA MTP Vehicular Adapter Instruction Manual (Motorola publication number 68P81088C78-O). These are changes that have occurred since the publication of FMR1908-2 on 9/15/00.

General Instructions

Replace pages 47 to 54 with the replacement pages provided.



VIEWED FROM SIDE 1

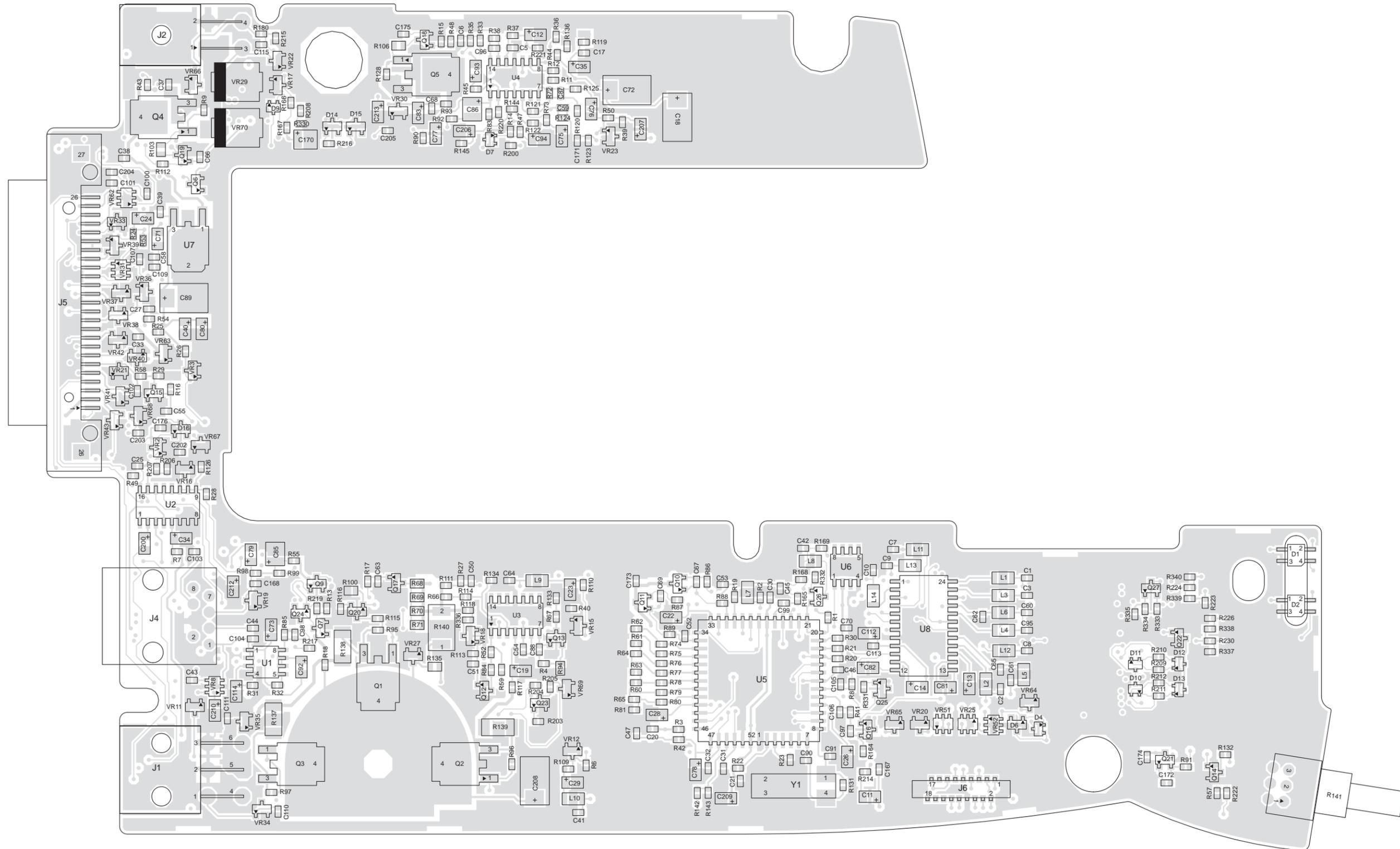

MAEPF-26683-O

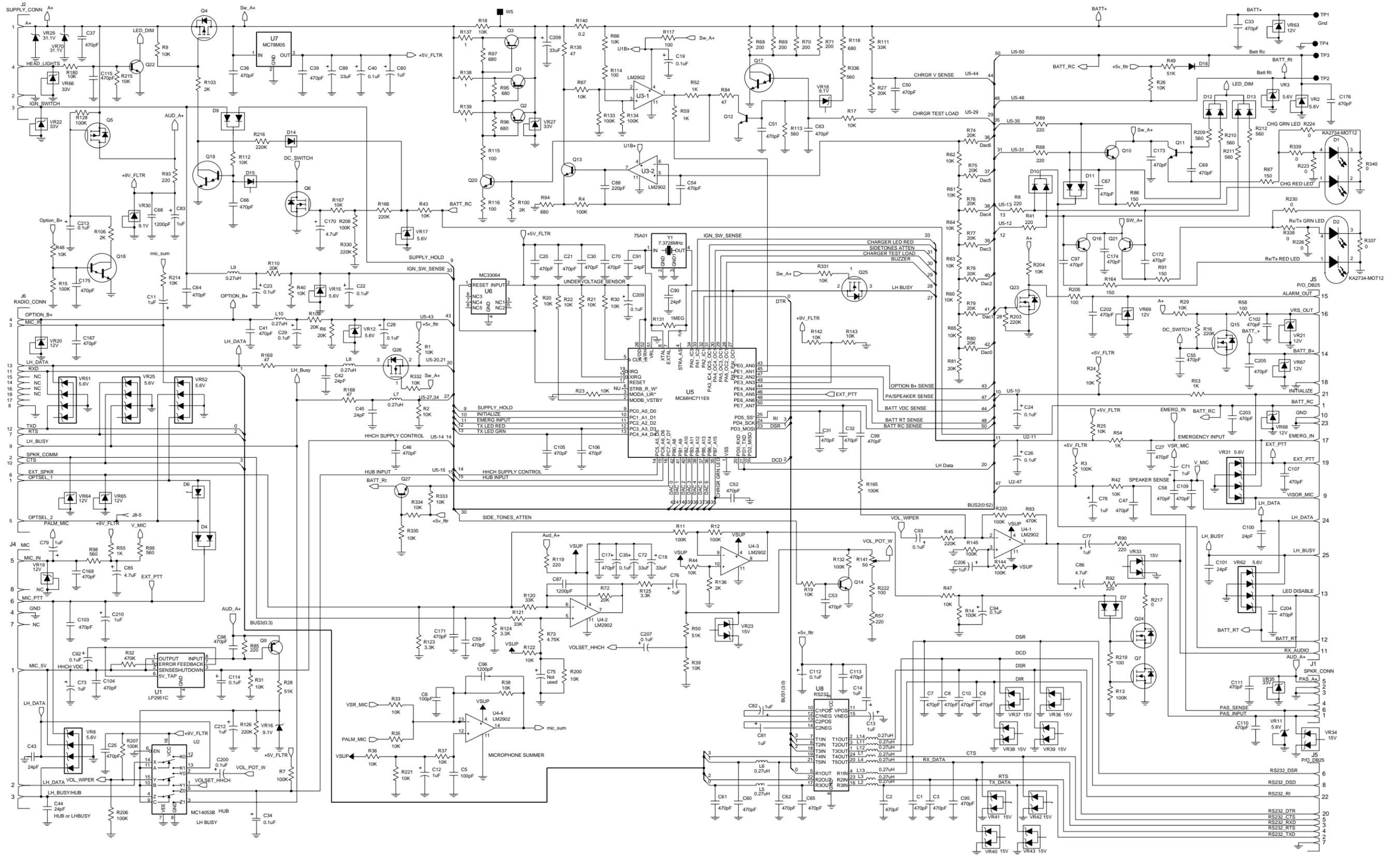

63A81090C66-A

ASTRO XTS Vehicular Adapter Console
Revision Level A Printed Circuit Board Schematic Diagram

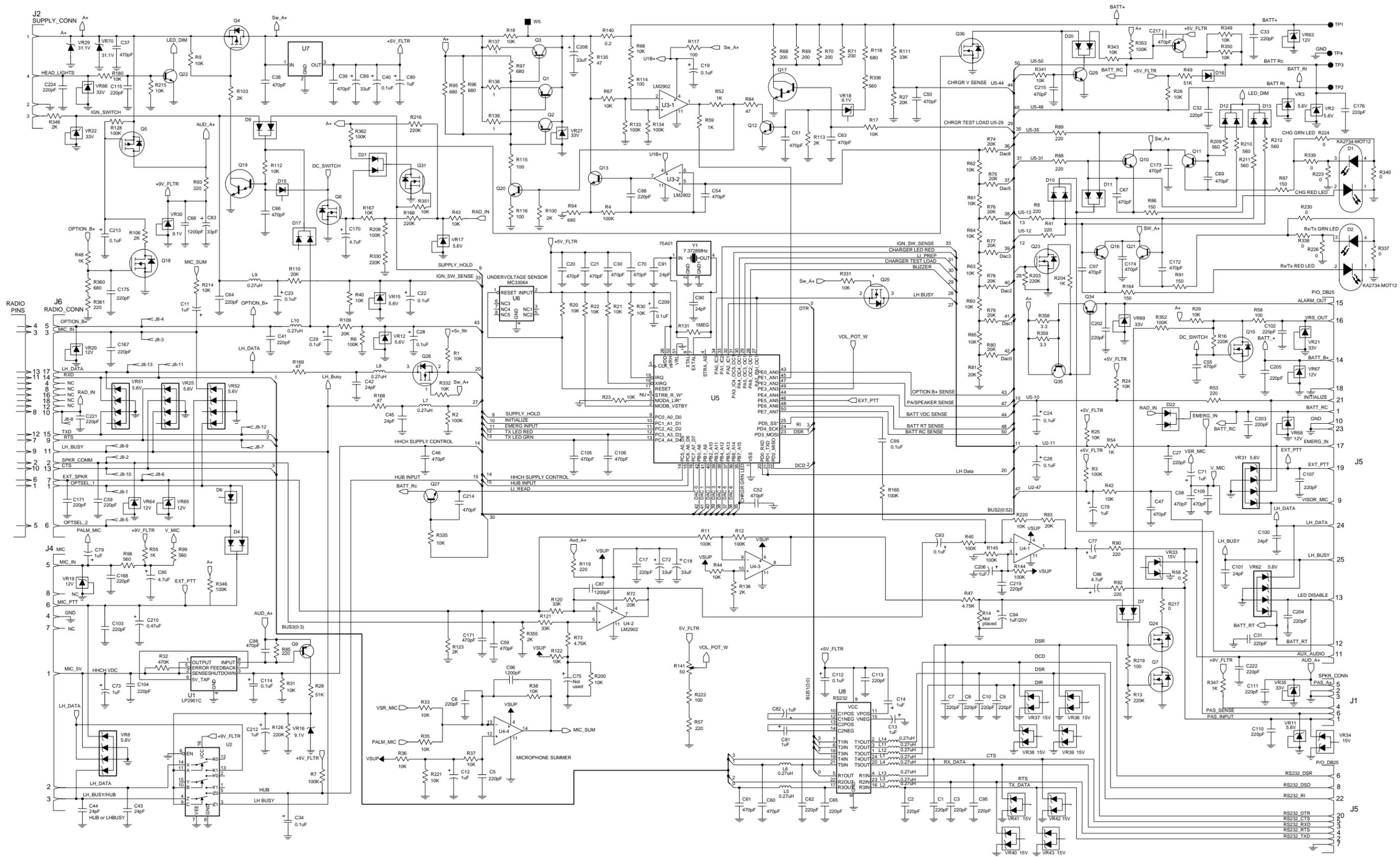

63A81090C67-A

**ASTRO XTVA Console
Exploded View Parts List**

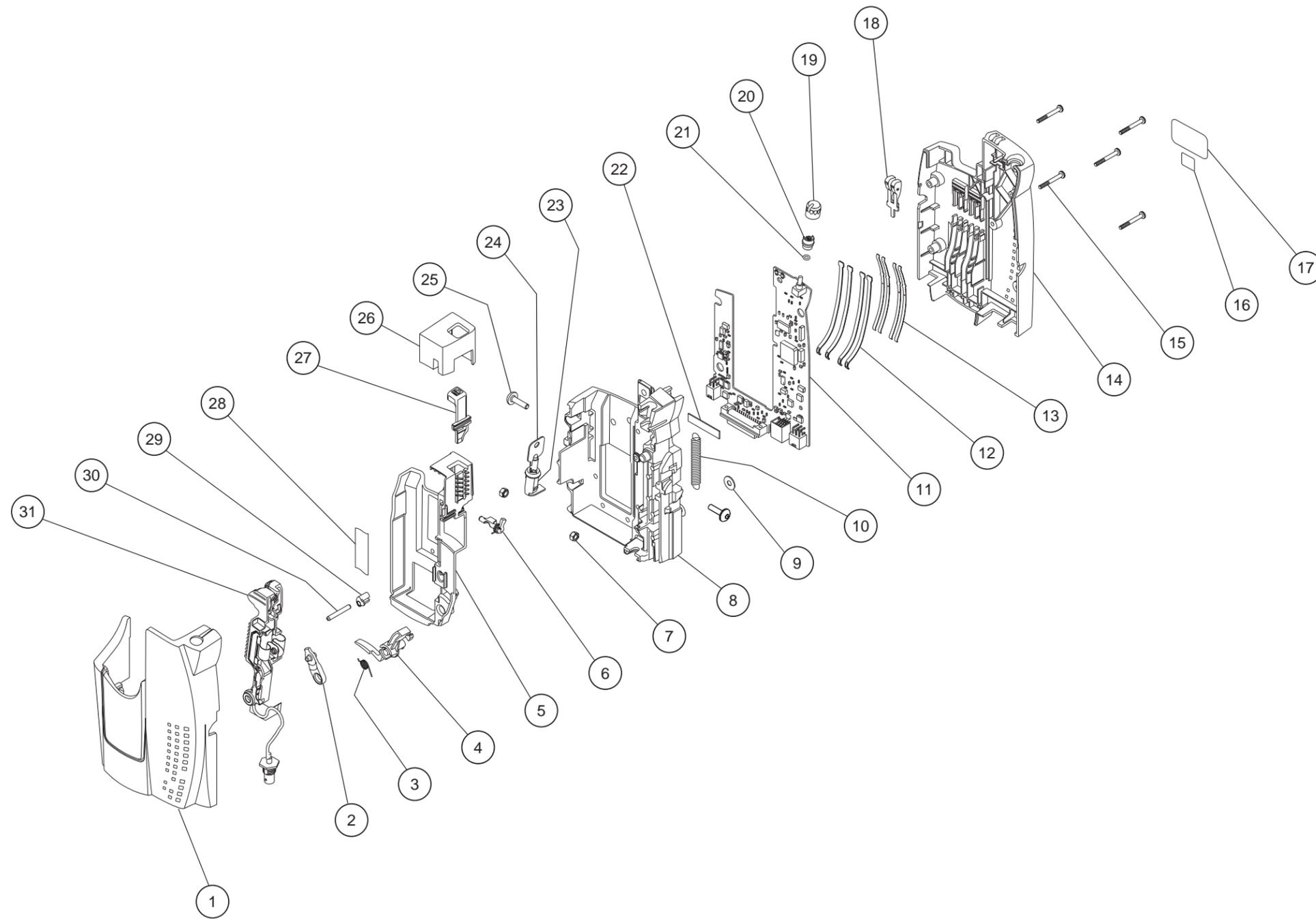

ITEM NO.	MOTOROLA PART NUMBER	DESCRIPTION
1	1585760A04 or 1585760A05	HOUSING, Front (Closed) HOUSING, Front (Open)
2	4586149A01	LINK (part of item 31)
3	4185768A01	SPRING, Kicker
4	4585767A01	KICKER
5	1585762A03	HOUSING, Pocket (includes item 28)
6	0105956V42	ASSEMBLY, Latch
7	0286146A01	NUT, Trunion (2 req'd)
8	2785761A02	CHASSIS (includes item 9)
9	7586151A01	PAD, Thermal (part of item 8)
10	4185770A01	SPRING, Eject
11	0105956U22	KIT, PCB Assembly (for Rev. B and higher consoles only)
12	3985878B01	CONTACT, Charge (4 req'd)
13	3985879B01	CONTACT, PCB (4 req'd)
14	1585822A03	HOUSING, Back
15	0310908A96	SCREW, Back Cover (5 req'd)
16	5405247W06	LABEL, Date Code
17	3305409X32	LABEL, Nameplate
18	6186158A01	LIGHTPIPE
19	3605371Z01	KNOB, Volume
20	4305372Z01	INSERT, Knob
21	3205082E98	O-RING
22	1485923B02	INSULATOR
23	5586156A01	LOCK (includes item 24)
24	5586156A02	KEY (part of item 23)
25	0385881B01	SCREW, Button Head (2 req'd)
26	1585763A02	HOUSING, Pocket Lid
27	3886293A01	BUTTON, Eject
28	3305455U08	LABEL, Caution (part of item 5)
29	4386148A01	BUSHING, Universal
30	4786150A01	PIN
31	0105956V68	ASSEMBLY, Universal Coax (includes item 2) (for Rev. B and higher consoles only)
---	3005297Y03	CABLE, Power (Not Shown)