

**PLEASE READ AND SAVE
ALL INSTRUCTIONS!**

**LISEZ ET CONSERVEZ
TOUTES LES INSTRUCTIONS!**

**¡POR FAVOR LEA Y
GUARDE TODAS
LAS INSTRUCCIONES!**

AIR-O-SWISS 
ADVANCED AIR TREATMENT SYSTEMS

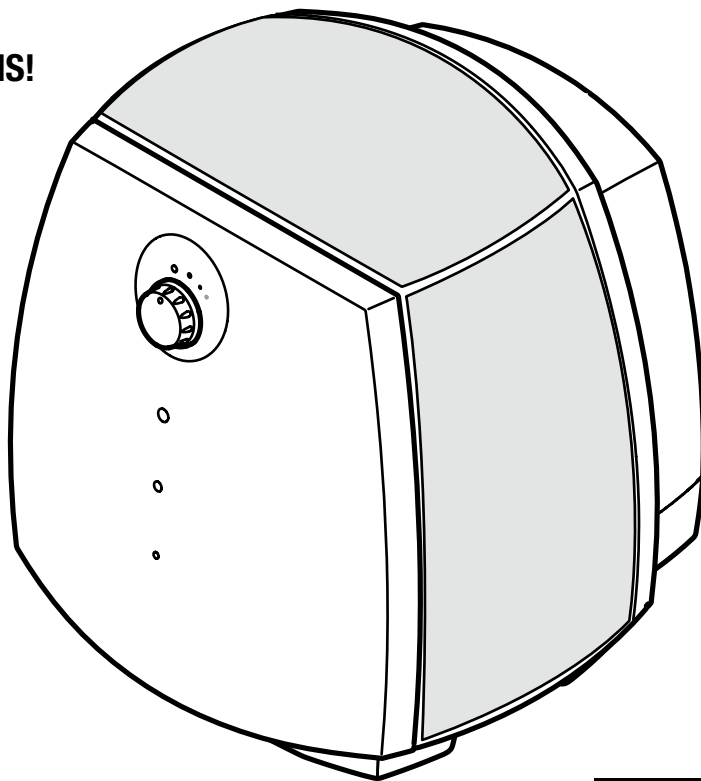

AOS 2055A



Instructions for use (5 – 18)

en

Instructions d'utilisation (19 – 32)

fr

Instrucciones para el uso (33 – 46)

es

PLEASE READ AND SAVE ALL THESE INSTRUCTIONS!

Important safety instructions

- Prior to using the appliance, read through the instructions for complete use and retain in a safe place for later reference.
- **WARNING** – Only use the appliance indoors and within the specified technical data. Improper use can be hazardous for the health and lead to critical injury.
- Connect the unit only to alternating current with voltage according to the rating label.
- Children cannot recognize the hazards associated with the usage of electrical appliances. For this reason, always supervise children when they are near the humidifier (image 1).
- Never use the appliance if there is any damage to the appliance or cable (2), after malfunction, after the appliance has been dropped (3) or damaged in any other way.
- Repairs of electrical appliances are only to be made by qualified service engineers (4). Improper repair work can cause considerable danger to the user.
- Place the humidifier on a dry, level surface (5).
- Do not place the appliance next to heating vent.
- Place appliance where it is not easily knocked over (6).
- Always unplug when not in use.
- Only operate the humidifier when it is completely assembled.
- **ALWAYS** unplug before removing/filling/emptying the water tank, before cleaning/maintaining, assembling/dismantling of individual parts and before moving the appliance.
- Do not run power cords under carpets, and do not cover with throw rugs. Arrange cord so that it will not be tripped over.
- Never pull the plug from the outlet by the cable or with wet hands (7).
- Do not use the appliance where combustible gases or vapors are present.
- Do not expose the appliance to rain, or use near water, in a bathroom, laundry area or other damp location.
- This unit must be used in its upright position.
- Do not allow foreign objects to enter ventilation or exhaust opening as this may cause electric shock or damage to the appliance. Do not block air outlets or intakes (8).
- This appliance has a polarized plug (one blade is wider than the other). To reduce risk of shock, this plug is intended to fit in a polarized outlet only one way. If the plug does not fit fully in the outlet, reverse the plug. If it still does not fit, contact a qualified electrician. **DO NOT** attempt to alter this safety feature.
- A loose fit between the plug and the AC outlet (receptacle) may cause overheating and a distortion of the plug. Contact a qualified electrician to replace loose or worn receptacles.
- Do not sit, stand or place any heavy objects on the appliance.
- Do not submerge the main body in water or other liquids.
- Disconnect power supply before servicing.
- Persons who are not familiar with the instructions for use, as well as children and persons under the influence of medication, alcohol, or drugs are not permitted to operate the appliance, or are only permitted to operate it under supervision.
- The use of water additives, such as ethereal/essential oils, fragrances, eucalyptus, water conditioners etc., damages the tank material and as a consequence the whole unit. Any use of such additives in the tank will void the manufacturer's warranty. Please read chapter «use of fragrances».

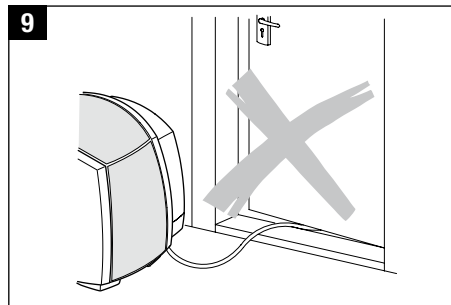
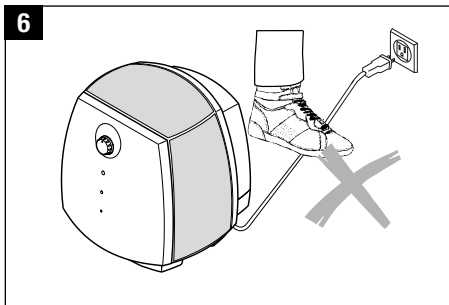
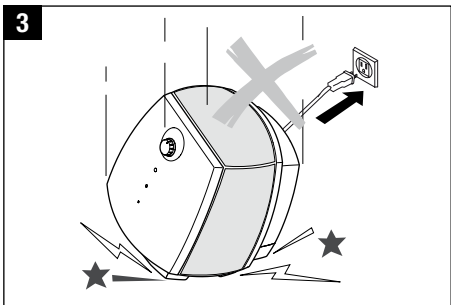
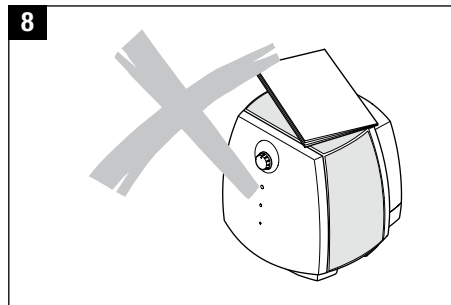
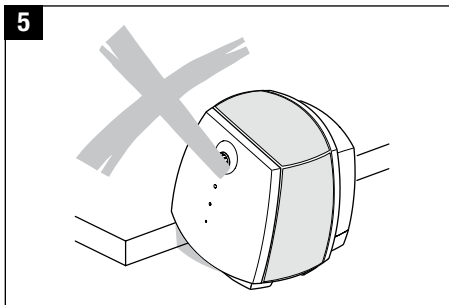
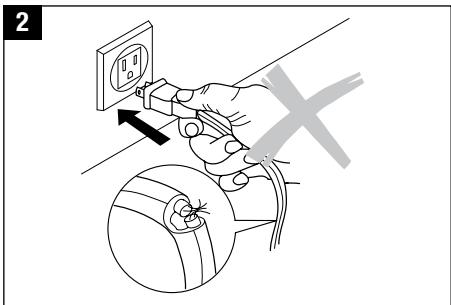
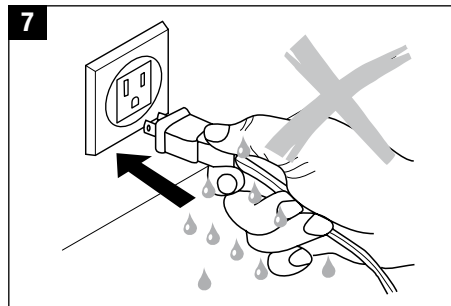
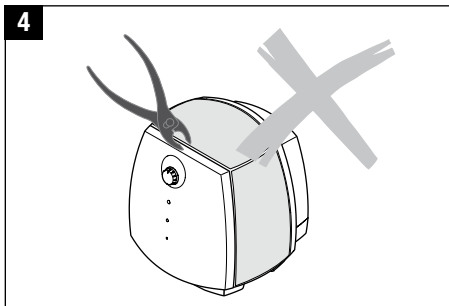
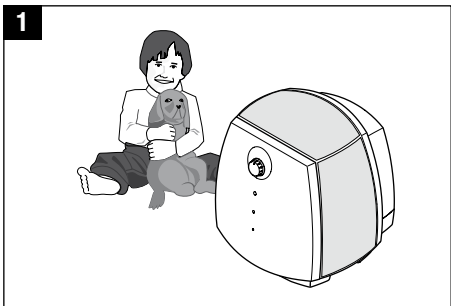

Foreword

Congratulations on purchasing the AIR-O-SWISS 2055A Air Washer!

Did you know that excessively dry indoor air

- dries out mucus membranes and causes chapped lips and stinging eyes?
- promotes infections and diseases of the respiratory tract?
- leads to weariness, tiredness and poor concentration?
- is a burden on pets and house plants?
- promotes the formation of dust and increases the electrostatic charge of textiles made from synthetic fibers, carpets and synthetic floors?
- damages furnishings made from wood, especially parquet floors?
- makes musical instruments go out of tune?

General

The indoor climate is generally pleasant when the relative humidity is between 40 and 60%. Air humidification is especially sensible in winter, but does not replace the regular airing of living spaces.

How it works

Your appliance

- washes and humidifies the air without using filter mats
- works quietly in two operation modes
- is manufactured from high-quality, long-life components.
- has a large cleansing capacity through pre-ionization. The individual dust particles are ionized (charged) and stick to the humidifier discs.

Special humidifying discs rotate in a water bath inside the unit; this cleanses the air passing over them of impurities in a natural way – in the same way that air is washed by the rain in nature.

The air humidification takes place according to the self-regulating principle of cold evaporation. The appliance therefore generates ideal air humidity, without the need for additional control units.

A specially tuned anti-microbial protection system (Ionic Silver Stick®) prevents the formation of microbes in the water of the base unit. No chemical additives are required to keep the water clean.

Unpacking

- Remove the appliance carefully from the packaging (10 – 12). Place your hands underneath the product to pull it out of the box. The top part of the unit is only placed on the base; it is NOT attached.
- Remove the plastic bag from the unit (13).
- Remove **all** cardboard pieces from the disc pack (14).
- Check the details of the electrical supply on the rating plate (15).
- Use the original packaging to store the appliance if you do not use it throughout the year.

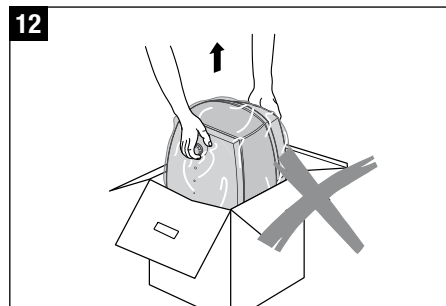
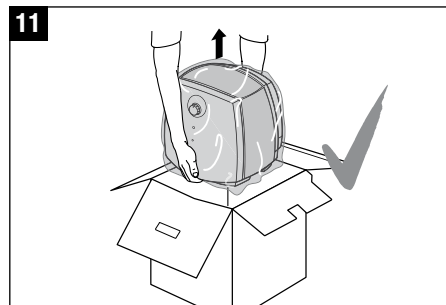
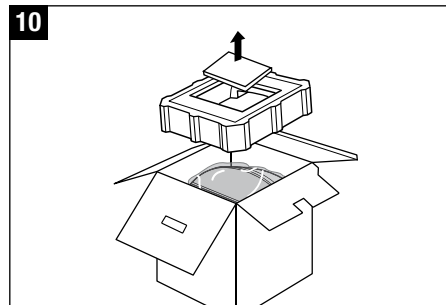

13

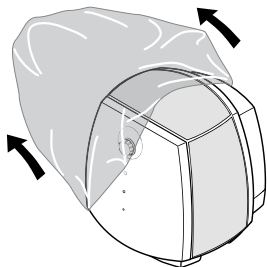

14

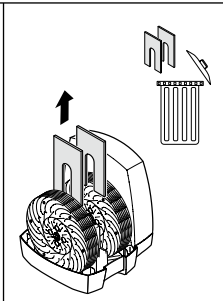
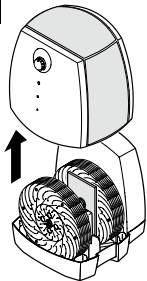

15

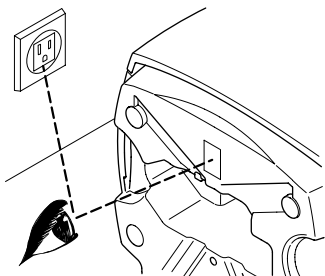

Description of the appliance

Air inlet

Cover

Control panel

Air outlet

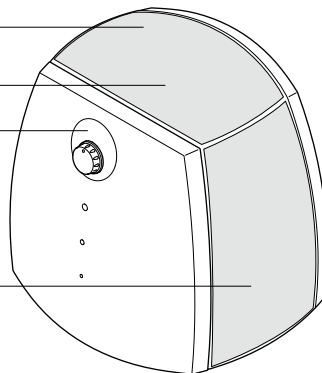
1 disc pack with
16 humidifying discs

Rotary lock

Fragrance container
and rotary lock opener
for humidifying discs

Water base

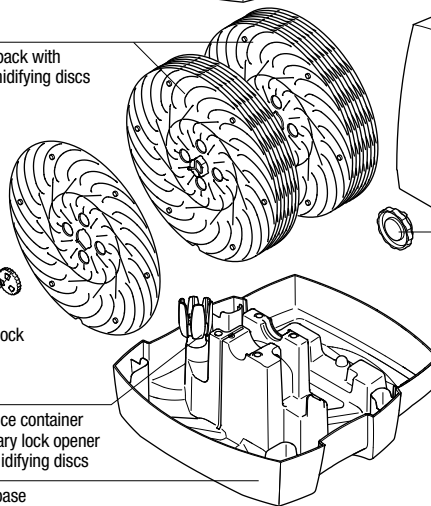

Putting into operation

The best location for your appliance is:

- On the floor, or on a level, dry surface in the room.
- Pay proper attention to easy accessibility and sufficient space for servicing and cleaning the unit.
- Read the section «Filling the tank» on how to fill the water tank (16 – 20).
- Place the water tank on the lower part (20).
- Connect the power cable to the outlet and switch the appliance on using the On/Off switch.
- The unit will reach full humidity output about 10 – 15 minutes after you switch it on.
- Ensure that the cable is not trapped (9). Do not switch on the unit if the cable is defective (2).

Water tank

Water tank cap

Hydro Stick

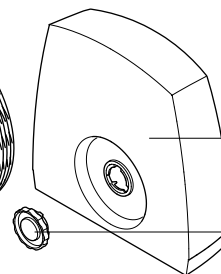

Filling the tank

Always unplug the unit before removing the water tank. Do not operate the appliance when the water tank is empty!



Only fill the water tank with fresh, cold tap water. Use water additives at your own risk. We do not accept any liability for possible reductions in performance or damage.

Do not put the water tank under pressure, e.g. by filling with carbonated mineral water. Do not add any essential oils or fragrances to the water; the plastic material might become discolored and damaged. Close cap tightly (19) to prevent water from leaking out of the tank.

- Remove the water tank (16).
- Ensure that there are no foreign objects in the water tank.
- Remove the water tank cap from the tank (17). Fill the tank with fresh, cold tap water (18). Fully close the water tank cap to prevent the water tank from leaking (19). Place the water tank on the water base (20).
- After filling the water tank, most of the water will empty into the base. The water tank may be filled a second time (base will not overflow).
- Connect the cable to the outlet and switch the appliance on.
- The red empty indicator light may stay illuminated for some seconds until the base is filled with water.

The unit is fitted with an automatic cut-off switch. As soon as the water tank is empty, the unit switches off automatically; the empty indicator illuminates (also see section «Operating 2055A»).

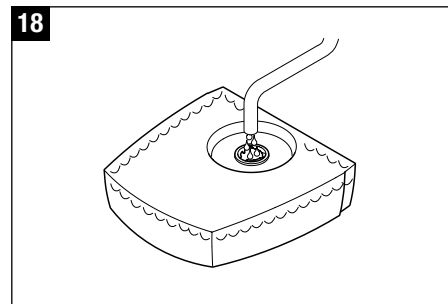
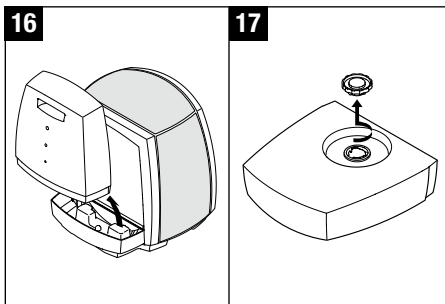

Use of fragrances

The base contains a special fragrance container (21). A cotton ball soaked with fragrance can be placed in this container. Place fragrances only in the container provided! Do not pour fragrances in fragrance container directly! Use with cotton ball only. Water additives (e.g. essential oils, fragrances, water conditioners) must NOT be used in the tank or anywhere else in the appliance! Even a small amount can damage the plastic or cause cracks. The material is not suitable for the use of additives. One drop is enough to damage the water tank and therefore render the unit unusable. Appliances that are damaged by additives are excluded from the warranty. The fragrance container is also used as a tool for opening the rotary locks of the humidifying discs. To learn more about removing the discs, refer to section «Cleaning the humidifying discs».

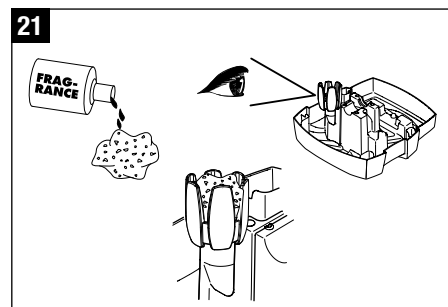
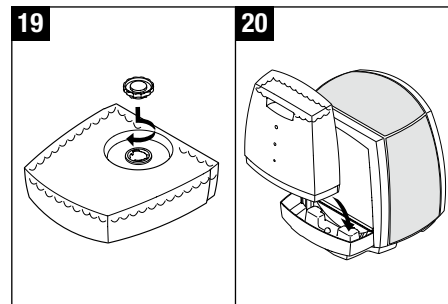

Operating AOS 2055A

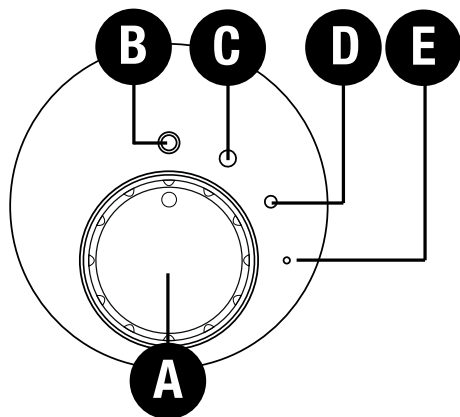

A) Rotary Dial

Connect the appliance to an outlet and turn rotary dial A from position B (off) to position C or D as required. Position D is especially quiet (night mode). Position C (normal mode) achieves maximum humidity output. The disc rotation speed remains constant with both mode selections. The fan rotation speed increases with level II (C).

B) Switching on/off

If the rotary dial is in position B, the appliance is switched off.

C) Normal mode

If you select position C, then normal mode is set, and the appliance reaches maximum humidity output.

D) Night mode

If you turn the rotary dial to position D, the appliance works in night mode and is especially quiet.

E) Operating light and Automatic Shut-Off «Tank empty»

The green light (LED) (E) illuminates when the appliance is switched on. The water level is easy to see thanks to the transparent water tank. The red LED light on the appliance also shows when the unit should be refilled with water. If the water level falls below the minimum level, the appliance automatically switches off. The red symbol (E) appears on the display. When water is added, the red LED changes to green and the appliance continues operating.

Warning: When lifting the upper part off the housing, the appliance also switches off. In this case, the red light E will also appear on the display. Only when the upper part is replaced on the base does the red LED (E) disappear and the appliance resumes operation.

Water quality maintenance

The AIR-O-SWISS Hydro Stick 7017 keeps AIR-O-SWISS humidifiers operating at their highest level between recommended cleanings*. Good for one year, the Hydro Stick ensures the humidifier's functionality while providing fresh humidification performance.

It starts to work as soon as it comes in to contact with water, even if the unit is turned off. The Hydro Stick should be changed every year. Look at picture 22 for the position of the Hydro Stick in the base part of the unit. Do not touch the water in the base during operation! Switch off the unit first. Contact your local retailer or check our website www.airoswiss.net for reorder information.

* Refer to the cleaning instructions in this manual.

Lifecycle indicator

Your appliance comes with a lifecycle indicator for changing the Hydro Stick. To remind yourself of when you put the Hydro Stick into operation, please cross the current month on the stamp and write the current year on the line provided (23).

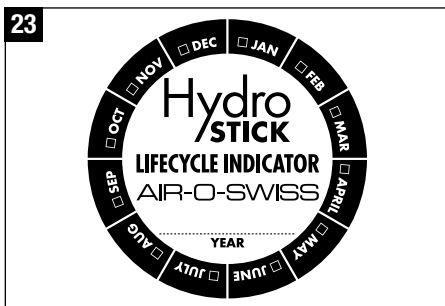
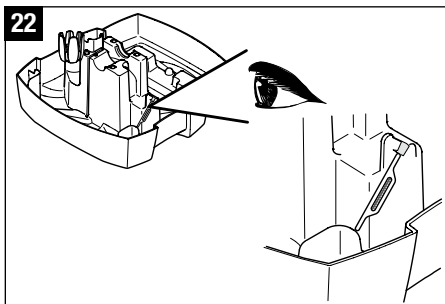

Cleaning/maintenance



Switch the appliance off and remove the power plug from the outlet before you clean the appliance (24).

- Regular cleaning is a pre-condition for hygienic, trouble-free operation.
- The appliance can be unassembled for cleaning in a few moves.
- Never submerge the entire unit in water (26).
- Empty and rinse the base once a week (27).
- The unit must be completely emptied and cleaned if it has been filled with water for longer than a week without being used.

Recommended cleaning intervals

The recommended cleaning intervals depend on the air and water quality, as well as operating times. A thin film of lime scale on the discs actually increases the humidity output!

- once to twice a year: upper part of housing and fan
- every 2 weeks: water tank and base
- every 4 weeks: humidifying discs

Cleaning the upper part of the housing

Remove the upper part of the unit (29) and wipe out thoroughly once to twice a year with a damp cleaning cloth (30).

Cleaning the fan

The cover can be removed from the upper part of the unit (31). Under this cover is the fan (32), which can be cleaned with a damp cleaning cloth as required.

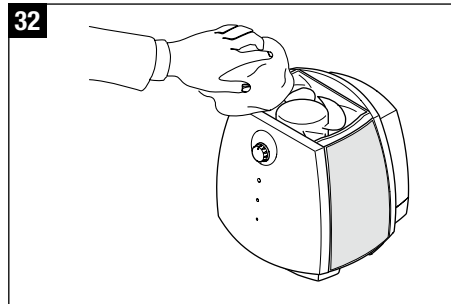
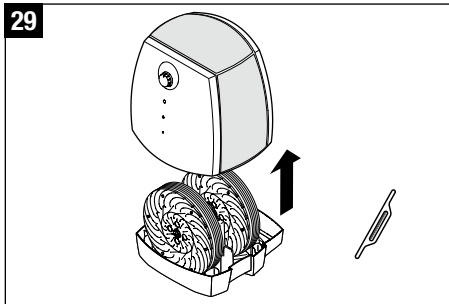
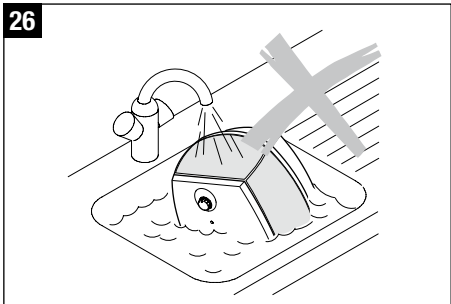
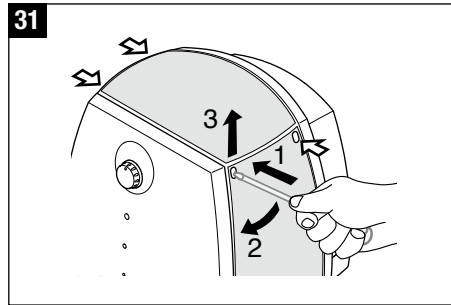
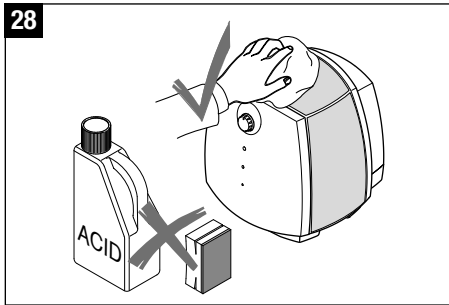
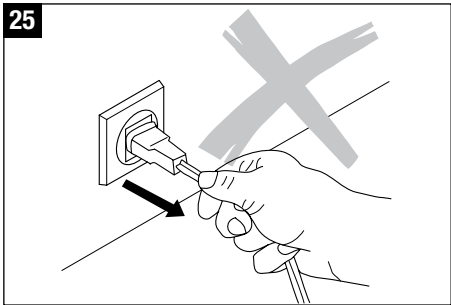
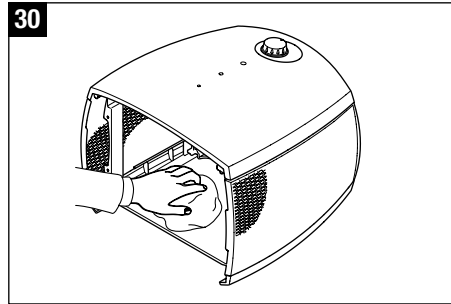
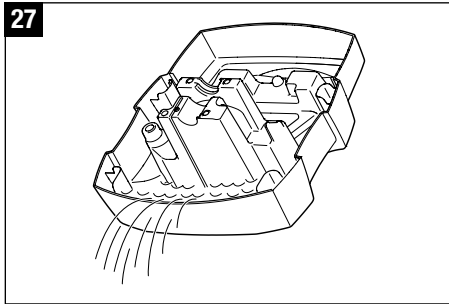
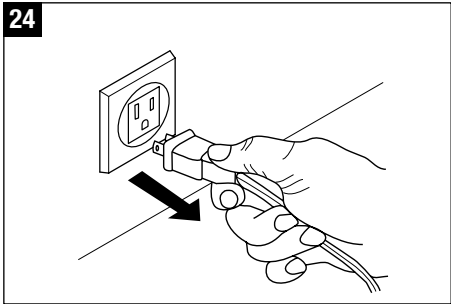

Cleaning the water tank and base (every 2 weeks)

- Lift the water tank out of the unit, open the water tank cap and clean the tank (33 – 35).
- Lift the upper part of the unit off the base and remove the Ionic Silver Stick® (36).
- Use AIR-O-SWISS EZCal custom cleaning and descaling agent only to remove deposits from the water base regularly (37). There is a sample of EZCal included in the packaging of your humidifier. Instructions for using are on the packet. Rotate the disc assembly a few times by hand (37) to clean the mineral deposits on the humidifying discs. Only use 1 packet for 32 oz of water. Do not change the ratio. Do NOT run the unit when using EZCal. This can cause damage to the product and voids the warranty. Thoroughly rinse the base with tap water after using EZCal and make sure no EZCal residues remain in the base.
- Empty the water base (38), remove the disc assembly (39) and rinse (40).
- Remove deposits from the base using a plastic or wooden brush (41).

Cleaning the humidifying discs (every 4 weeks)

A thin film of lime scale on the discs actually increases the humidity output! To clean, unscrew the individual humidifying discs from each other. Rotary locks (toothed wheels) can be easily removed using the multifunctional fragrance container (42).

Next, the discs can be washed individually (43 – 44). For best results use EZCal custom cleaning agent for AIR-O-SWISS products. Refer to section «Cleaning the water tank and base» for more information of how to use EZCal.

- The toothed wheel can only be assembled in one position.

After cleaning, reassemble the appliance in the reverse sequence. Note: rotary locks have two rest positions. Warning: Do not overtighten!

33

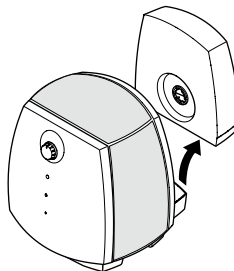

34

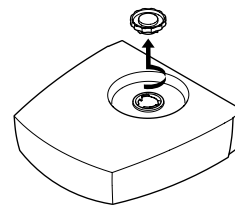

35

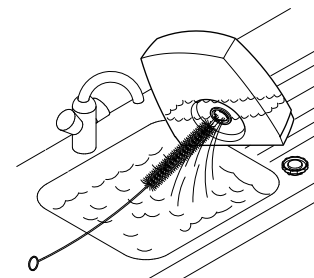

36

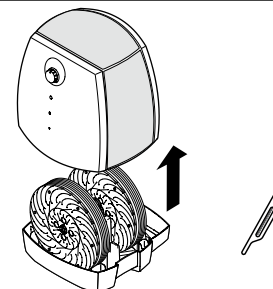

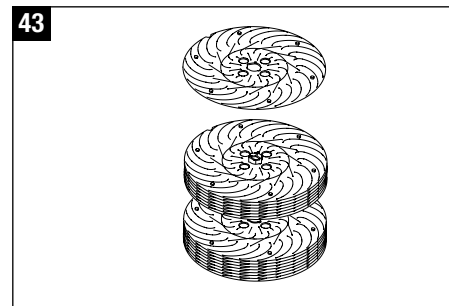
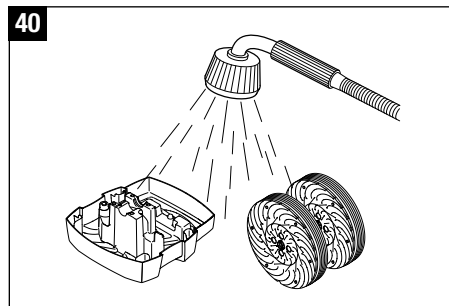
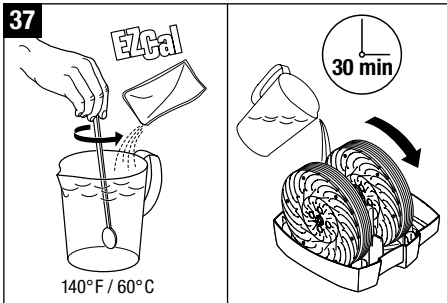

en

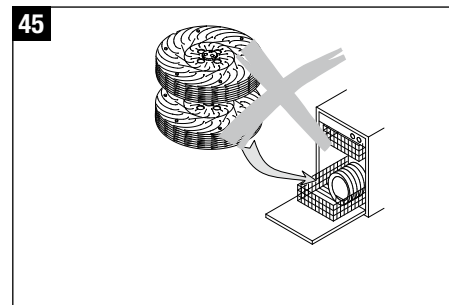
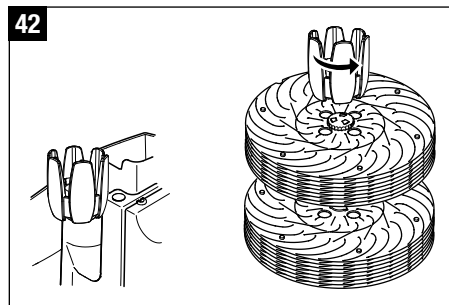
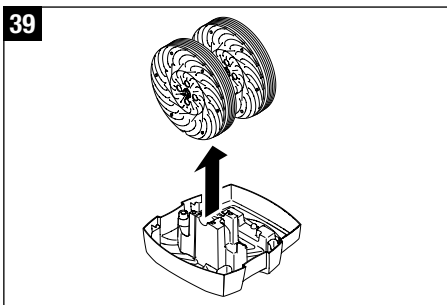
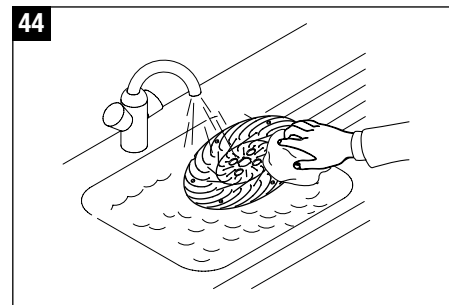
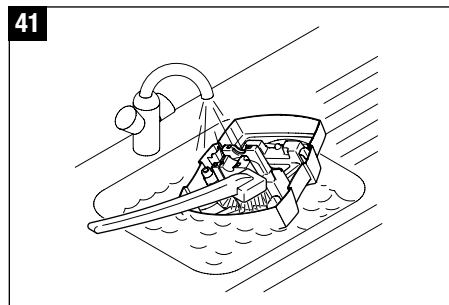
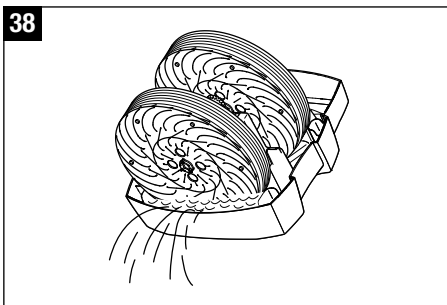

Storing the appliance for extended periods

Clean the appliance as described earlier and allow to dry thoroughly. Preferably store the appliance in its original box, in a dry place away from high temperatures.

Legal notice

The humidifier is cUL-listed.

Subject to technical change. The instructions for use are protected by copyright © PLASTON AG.

Accessories

Contact your local retailer or check our website www.airoswiss.net for re-order information.

Customer Service

Customer Service (USA) 1-800-336-0326

www.airoswiss.net

Technical specifications

Electrical voltage	120 V / 60 Hz
Power consumption	29 W
Humidity output up to	3 gallons / 24h
Suitable for rooms up to	600 sq ft / 55 m ²
Dimensions	14.2 x 14.2 x 14.2 in 36 x 36 x 36 cm
Weight (empty)	13 lbs / 5.9 kg
Operating noise level	< 25 dB(A)
Accessories	AOS 7017 Hydro Stick

Troubleshooting

Problem	Possible cause	What to do
Appliance does not work	Power plug not inserted	Connect power plug to the outlet Turn rotary switch to position ON
	No water in the water tank	Fill with water
Brushing noise	Disc assembly is not correctly inserted in the water base.	Insert the disc assembly correctly
	Discs warped	Replace discs
No humidification	No water in the water base	Fill the water tank

General Humidifier Questions

Q. Why isn't there enough moisture in my room?

A. How often do you run the unit? If the unit is only run at night, then during the day the moisture level will drop if moisture is not constantly added to the air.

A. Do you leave your door open or closed when the unit is running?

- a. By leaving the door open, this allows moisture to leave the room and go into other areas of the house. If you would like the moisture to stay within one specific room you should consider closing the door while the unit is running.
- b. Wood, leather, carpet, curtains, and other types of fabric soak up a lot of moisture, thus not leaving enough moisture for the air. If the window is left open, then this allows moisture to escape the room. Another factor is a lot of times the unit is placed next to a heating device. The idea is that the air blowing into the room will quickly place moisture around the room. Unfortunately, this concept does not work because the hot air coming out of a vent will soak up most of the moisture, and none of the air within the room will receive any.

Q. How much moisture do I need in my room?

A. Suggested humidity levels are between 40 – 60%.

Q. What are the effects of too little or too much humidity?

A. Dry air can cause dry skin, static electricity, out of tune musical instruments, increased levels of dust (dry air causes dust to rise), damage to wooden objects (dry out and eventually cracks appear), discomfort, sickness, and dries out nasal membranes. Over-humidifying the air can cause mold and wallpaper to peel.

Q. Why do I need a humidifier when I can just open my window?

A. The moisture level within the outside air is not high enough to humidify a room. The colder the air the less moisture it is capable to hold, and the more the air is heated up the percentage of relative humidity is lower. Relative humidity means the amount of water vapor in the air, compared to the amount the air could hold if it was totally saturated. The difference is higher between outside and inside temperatures; more humidification is needed because of the dry air in the room.

Q. Where should I place my humidifier?

A. The unit should be free-standing and not close to a wall, window, door, or thermal bridge so that air may circulate around the unit.

AOS 2055A FAQ's

Q. If there is no water left in my water tank, for how many hours will the water in base last?

A. An exact answer cannot be given for this as there are many factors that depend on how long the water will last for. It all depends on the size of the room, if it is very dry, among other things to know how quickly water will evaporate into the air. If you notice that there is no water left in the water tank, it is always a good idea to refill the tank to have extra water available.

Q. Red LED light is illuminated – what does it mean?

A. The red LED light on the appliance shows you when the unit should be refilled with water. If the water level falls below the minimum level, the appliance automatically switches off. The red light appears on the display. When water is added, the red LED changes to green and the appliance continues operating.

Please note: When lifting the upper part off the housing, the appliance also switches off. In this case, the red LED will also appear on the display. Only when the upper part is replaced on the base does the red LED (E) disappear and the appliance resumes operation.

Q. I fill the water tank, and when I place it back on the unit all of the water goes into the base. Why is that?

A. Water is needed in the base of the unit for the removal of particles from the air, and for the humidification of the air. The first time the tank is filled up and placed on the unit, all of the water will go into the base of the unit. The water tank acts as a reserve, and may be filled up a second time to have extra water available.

Q. Is it ok to put my humidifying discs in the dishwasher?

- A. The manufacturer of this appliance does NOT recommend it. The plates can only be placed in a dishwasher where the temperature is no greater than 131°F / 55°C. If the temperature is any hotter than this, the plates will melt. Place the plates in a sink filled with warm water and white vinegar or EZCal and either let them soak or spin the plates in this solution. Or, add white vinegar or EZCal to the water in the base of the unit and let the unit run for an hour to clean the plates. It is good to have calcium deposits built up on the plates as it will capture more particles from the air and add more moisture to the air.

Q. Humidity level is not changing or does not reach the desired humidity level

- A. If the water tank needs refilling more than once per day, the unit is working properly and the climatic condition in the room has an influence on the humidity.

Reasons for low humidity level:

- air circulation is very high (air is fully exchanged several times per day – the humidifier needs to start its work from scratch)
- insulation of home (see air circulation)
- open space with high ceilings (not only the footage of the room counts but also the height) – high-rise buildings require more humidification.
- open windows – works similar to air circulation (if it is very cold outside don't open the window more than 2 times per day for 3 minutes)
- big difference between outside temperature and inside temperature – the colder the air the less moisture it is capable to hold and the more the air is heated up the lower is the percentage of relative humidity (= the amount of water vapor in the air, compared to the amount the air could hold if it was totally saturated)

- position of the unit – if it is placed close to a door, window or air vent. This increases the air circulation.

Q. Can this unit be used all year round?

- A. Yes, the unit can be used all year round. The unit produces relative humidity which means that the air will only take as much moisture as it can hold. The unit will not over-humidify the air.

For troubleshooting, see chapter «Troubleshooting».

Accessories

Q. What is the Hydro Stick and how long is it good for?

- A. The AIR-O-SWISS Hydro Stick keeps humidifiers operating at their highest level between recommended cleanings*. Good for one year, the Hydro Stick ensures the humidifier's functionality while providing fresh humidification performance. It needs to be replaced once a year.

* Refer to the cleaning instructions in this manual.

Q. Placement of the Hydro Stick

- A. Please see picture 22 for instructions.

Q. Replacement reminder

- A. In each Hydro Stick box and on all the new products there is a Hydro Stick lifecycle indicator. Check the box of the month when starting to use the Hydro Stick and write the year on the line indicated. Exchange it after one year.

Q. What is EZCal?

- A. There is a sample packet of EZCal included in the packaging of your humidifier. EZCal is used for cleaning and descaling any of the AIR-O-SWISS humidifiers and cleans mineral build-up. EZCal is the only recommended cleaning and descaling solution. Do NOT use any other cleaning solutions since it can damage the product. Any use of cleaning solutions apart from EZCal will void the warranty. Instructions for using are on the packet. Only use 1 packet for 32oz of water. Do not change the ratio. It can also be used for other humidifier brands. Thoroughly rinse the base with tap water and make sure no EZCal residues remain in the base! EZCal is available at selected retail stores and online www.airoswiss.net.

Please check our website www.airoswiss.net
for further information.