

Service Manual

Altronic III Ignition System Units with 373XXXH-Series Circuit Boards

Medium Engines, 2-16 Cylinders

Form ALT III SM 3-11

altronic
HOERBIGER Engine Solutions



TABLE OF CONTENTS

SECTION	ITEM	PAGE
1.0	SYSTEM DESCRIPTION	3
2.0	PARTS IDENTIFICATION AND SPECIFICATION	4
2.1	Parts List – Alternator	5-6
2.2	Part Number Designation	6
2.3A	Discontinued Part Numbers	7
2.3B	Caterpillar OEM Part Numbers	8
2.4	Unit Specifications	8-10
2.5	Circuit Board Assembly	11
2.6	Connector Specifications	11
2.7	Bearing Fit Tolerances	11
3.0	PERFORMANCE SPECIFICATIONS	11
3.1	Voltage Test	11
3.2	Operating Test	11
3.3	Timing Specifications	11-15
4.0	TROUBLESHOOTING	16
4.1	Circuit Diagram	16
4.2	Troubleshooting Guide	17
4.3	Oscilloscope Tests	18
5.0	SERVICE – BACK COVER ASSEMBLY	19
5.1	Circuit Board Assembly Replacement	19
5.2	Pickup Coil Replacement	20
5.3	Bearing, Timer Arm, Driven Gear Replacement	21
6.0	SERVICE – ALTERNATOR SECTION	22
6.1	Disassembly – Coupling	22
6.2	Disassembly – Flange Mount Unit	22
6.3	Disassembly – Stator	22
6.4	Disassembly – Bearings	22
6.5	Parts Replacement	23
6.6	Reassembly – Front Housing Assembly	23
6.7	Reassembly – Alternator	24
6.8	Reassembly – Flange Mount Unit	25
6.9	Reassembly – Coupling	25
6.10	Reassembly – Back Cover to Alternator	25
7.0	SERVICE – ASSEMBLY TOOLS	26
8.0	OPERATIONAL TEST	26

IMPORTANT SAFETY NOTICE:
PROPER INSTALLATION, MAINTENANCE, REPAIR AND OPERATION OF THIS EQUIPMENT IS ESSENTIAL. THE RECOMMENDED PRACTICES CONTAINED HEREIN SHOULD BE FOLLOWED WITHOUT DEVIATION. AN IMPROPERLY INSTALLED OR OPERATING IGNITION SYSTEM COULD CAUSE PERSONAL INJURY TO OPERATORS OR OTHER NEARBY PERSONNEL.

1.0 ALTRONIC III IGNITION SYSTEM – DESCRIPTION

Altronic III is an alternator-powered, electronic ignition system. All electronic parts are mounted to the back cover which disconnects from the alternator section as a module.

The alternator (A) provides the power to charge the energy storage capacitor (B). A separate pickup coil (C) and SCR (D) are used for each of the system's outputs, which usually correspond to each engine cylinder. A rotating timer arm (E), driven through speed-reducing gears, passes over the pickup coils to trigger the SCR switches to the on state in sequence. This releases the capacitor's stored energy to the ignition coils, which step up the voltage to fire the spark plugs.

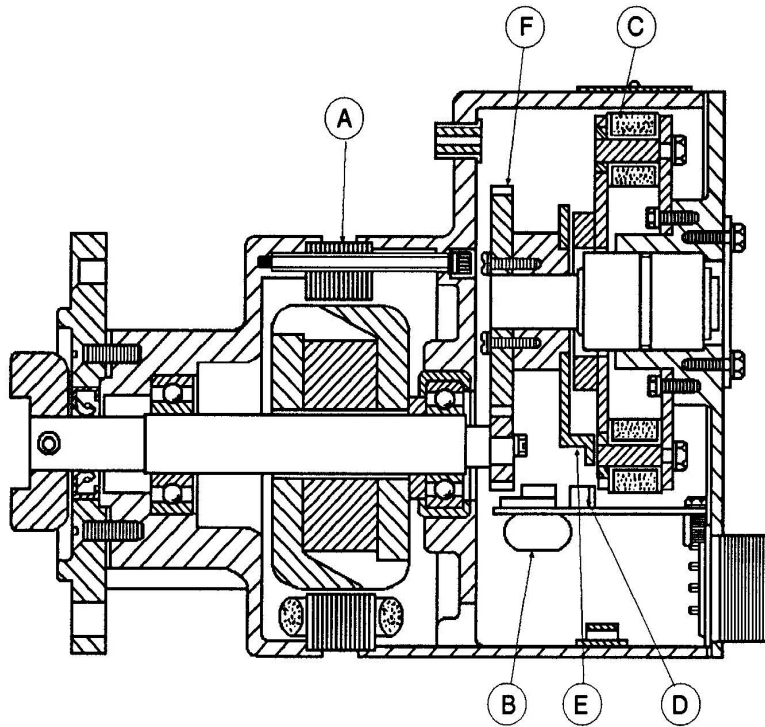

CROSS-SECTIONAL VIEW — ALTRONIC III UNIT

- A – Alternator
- B – Energy Storage Capacitor
- C – Pickup Coil
- D – SCR Electronic Switch
- E – Timer Arm
- F – Distribution Gears

2.0 PARTS IDENTIFICATION AND SPECIFICATION

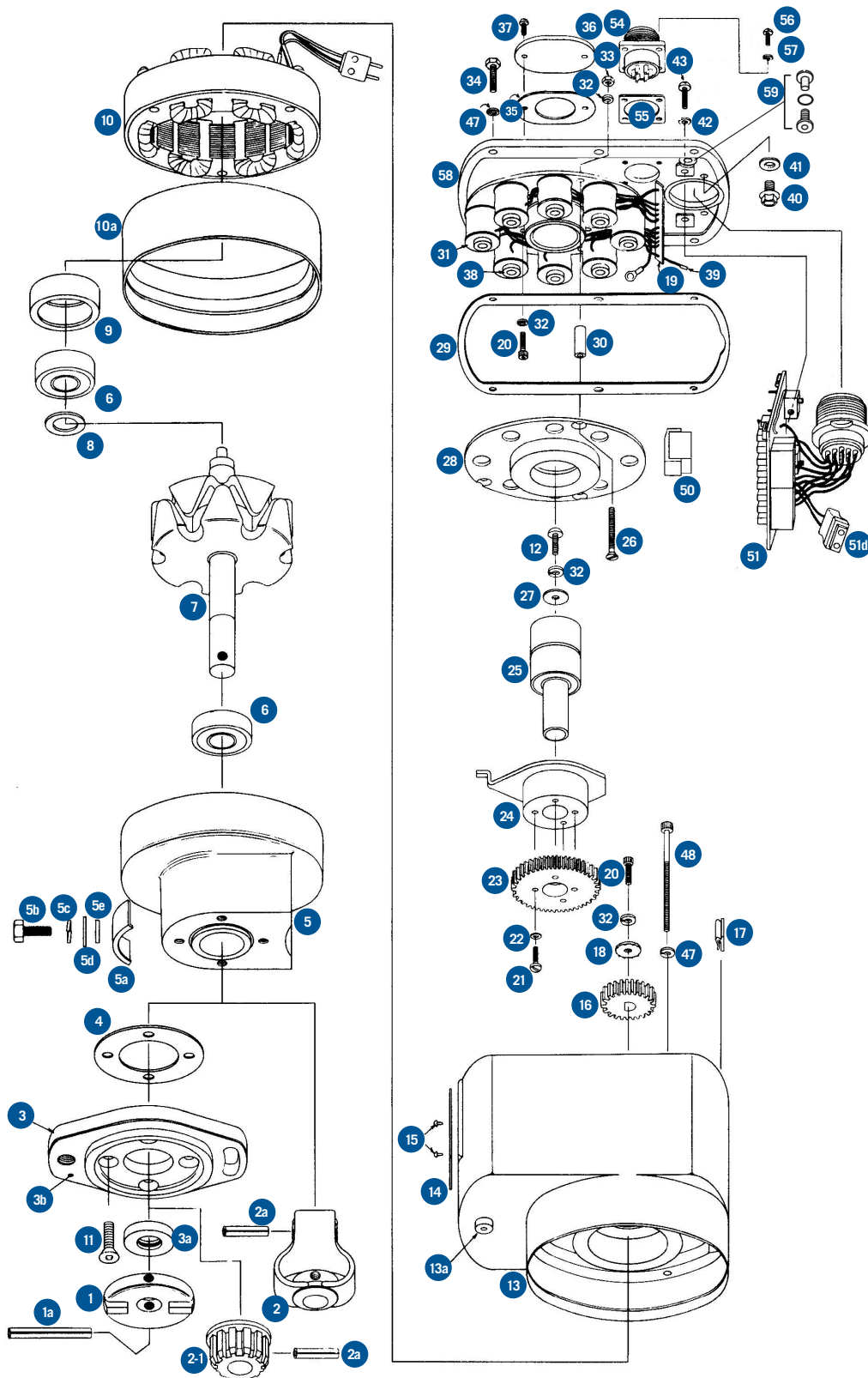

2.1 PARTS LIST – See exploded view, page 4.

Reference numbers with a letter suffix are part of an assembly of the same number without a suffix. Example: (1a) is part of (1).

REF. NO.	PART NO.	DESCRIPTION
1	510454-P	Coupling - BLACK
	510454-U	Coupling - YELLOW
1a	902478	Spring pin 2-1/8" lg.
2	560002	Flex coupling w/pin
2-1	560006	Gear coupling w/pin
2a	902475	Spring pin 1-1/8" lg.
3	310418-2	Flange (-GN, GVN)
	360465-1	Flange ass'y. (-A)
	360465-2	Flange ass'y. (-G, GV)
	360465-3	Flange ass'y. (-D)
	360465-4	Flange ass'y. (-AO)
	360465-5	Flange ass'y. (-GO)
	360466	Flange ass'y. (-J)
3a	510463	Oil seal
3b	510560	Gasket- mounting
4	310490	Gasket
5	360401-F	Front housing (flange)
	360401	Front housing (-EL)
	360405	Front housing (-BEL)
5a	310414	Shield
5b	902543	Screw 5/16-18
5c	901010	Lockwasher 5/16
5d	901347	Washer 5/16
5e	902554	Washer
6	510452	Bearing
7	360402	Shaft-rotor ass'y.
	360404	Shaft-rotor ass'y. "X" unit
8	310466	Spacer - bearing
9	510459	Cover - bearing
10	See Pgs 8-10	Stator
10a	310421	Seal band - stator
11	902484	Screw 1/4-20
12	902541	Screw 8-32
13	310355-12	Intermediate housing
13a	510550	Ventilator, screen
	510550A	Ventilator, 6-hole
14	302093	Nameplate
15	902520	Drive pin

REF. NO.	PART NO.	DESCRIPTION
16	310460	Drive gear 4:1
	310518	Drive gear 1.5:1
	510357	Drive gear 2:1
	510359	Drive gear 3:1
	510447	Drive gear 2.5:1
	510476	Drive gear 1:1
17	501212	Wire clamp
18	901326	Washer #8
19	310408	Wire guide 16 cyl.
	310473	Wire guide 2-12 cyl.
20	902465	Screw 8-32
21	902500	Screw 6-32
22	900423	Lockwasher #6
23	310461	Driven gear 4:1
	310519	Driven gear 1.5:1
	510358	Driven gear 2:1
	510360	Driven gear 3:1
	510446	Driven gear 2.5:1
	510477	Driven gear 1:1
24	See Pgs 8-10	Timer arm
25	310371	Bearing-shaft
26	902448	Screw 8-32
27	302106	Timing label - shaft
	302127	Timing label - S1 unit
	302128	Timing label - S2 unit
28	See Pgs 8-10	Magnet-plate ass'y.
29	310392	Gasket
30	310378	Spacer
31	351001	Pickup coil - BLACK
	351002	Pickup coil - WHITE
	351003	Pickup coil - WHITE 16-cyl.
32	900944	Lockwasher #8
33	901679	Nut 8-32
34	902472	Screw 10-24
35	302094	Timing label - cover
36	310365	Cover plate
37	902064	Screw 6-32
38	350001-2	Core ass'y. - pickup

CHART CONTINUES ON NEXT PAGE

2.1 PARTS LIST (continued) – See exploded view, page 4.

39	504072	Receptacle
40	902540	Screw 1/4-20
41	902577	Washer
42	902524	Washer
43	902355	Screw 8/32
47	901004	Lockwasher #10
48	902601	Screw 10-24
50	310596	Brace
51	See pgs 8-10	Circuit board ass'y.
51d	304102	Socket
54	362008-1*	Connector ass'y. - 3 leads
	362008-2*	Connector ass'y. - 6 leads
55	501335*	Gasket

56	902525*	Screw 4-40
57	900996*	Lockwasher #4
58	310474	Cover casting 8-12 cyl.
	310475	Cover casting 2-6 cyl.
	310538*	Cover casting 8-12 cyl.
	310539*	Cover casting 2-6 cyl.
	310559	Cover casting 16 cyl.
59	310560*	Cover casting 16 cyl.
	902734	Blanking screw
	902735	Binder post
	902736	O-ring

* Parts for units with electronic timing option.

2.2 PART NO. DESIGNATION

8 A 2 9 H T - BEL

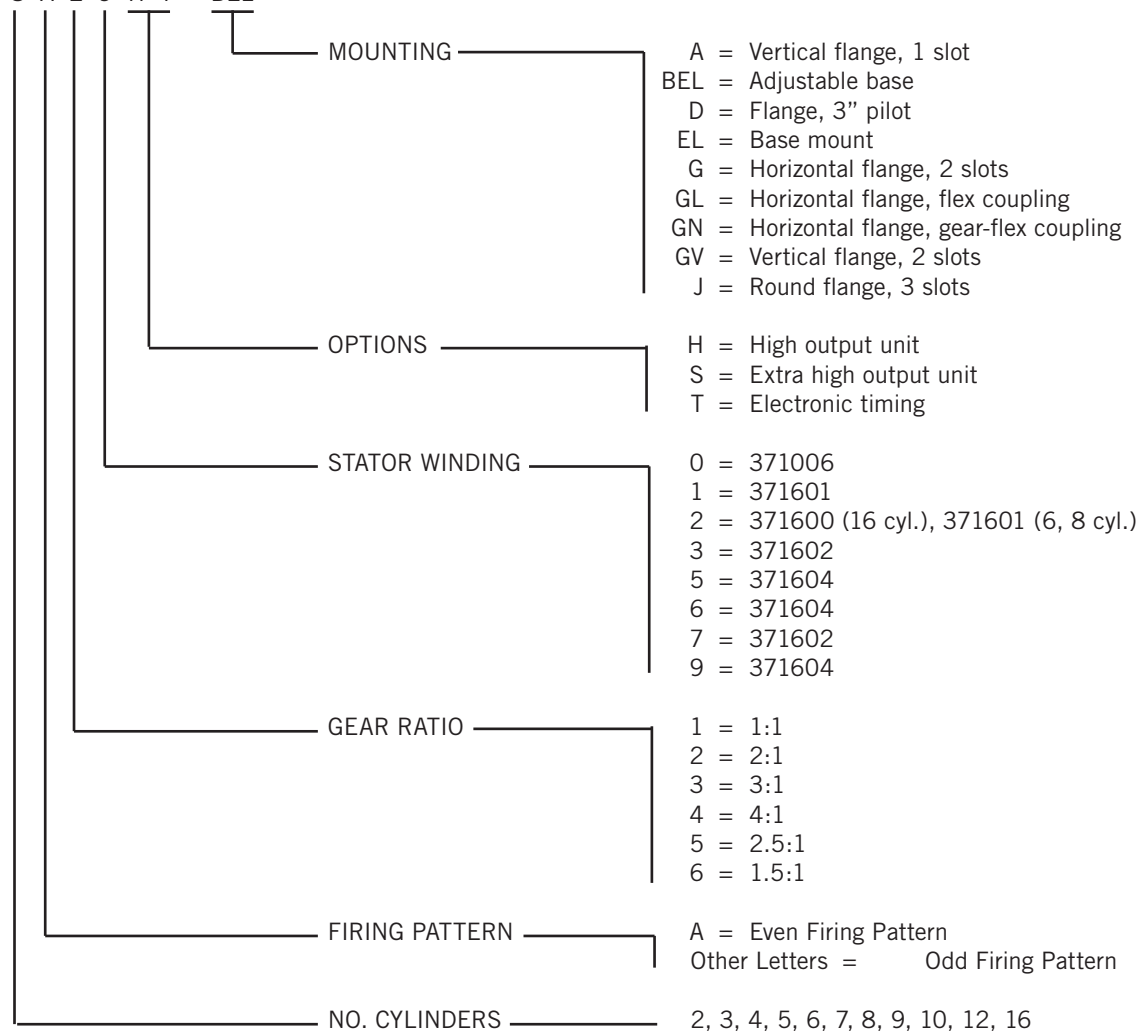

2.3A DISCONTINUED PART NUMBERS – Follow specification for replacement unit.

DISCONTINUED	REPLACEMENT	DISCONTINUED	REPLACEMENT	DISCONTINUED	REPLACEMENT
2A10H	2A19H (2)	8A25	8A25H	10A55	10A53H (1) (2)
2A20, 2A20H	2A29H (2)	8A26	8A25H	10A56	10A53H (2)
3A20	3A29H (2)	8A28	8A29H	10D56	10D55H
4A20	2A29H (2)	8A29	8A29H	10E56	10E55H
4A28	4A29H	8A30, 8A30H	8A39H (2)	10H11	10H11H
4A29	4A29H	8A33, 8A33H	8A37H	10P56	10P55H
4F28	4F29H	8A35, 8A35H	8A39H	12A23	12A23H
4F29	4F29H	8A38	8A39H	12A24	12A25H (1)
4G28	4G29H)	8A39	8A39H	12A25	12A25H (1)
4G29	4G29H)	8B13	8B13H	12A31H	12A33H (2)
5A58	5A59H	8B20	8B25H (2)	12A33	12A33H
5A59	5A59H	8B24	8B25H	12A34	12A33H (1) (2)
6A12XS	6A17XS (2)	8B25	8B25H	12A34D	12A33H (2)
6A13	6A17H	8B26	8B25H	12A35	12A33H (1) (2)
6A14F	6A17H (2)	8B28	8B29H	12B11	12B11H
6A27, 6A27H	6A29H (2)	8B29	8B29H	12C43H	12C45H (2)
6A28	6A29H	8B35	8B35H	12D34	12D35H (1)
6A29	6A29H	8C24	8C25H	12D35	12D35H (1)
6A32S	6A37S (2)	8C26	8C25H	12D36H	12D35H
6A37, 6A37H	6A39H (2)	8E29	8E29H	12E13	12E11H (2)
6A38	6A39H	8E49	8E49H	12E23	12E23H
6A39	6A39H	8F24	8F25H	12E53	12E53H
6B38	6B39H	8F26	8F25H	12G13	12G11H (2)
6B39	6B39H	8G28	8G29H	12H34	12H35H
6C38	6C39H	8G29	8G29H	12H35	12H35H
6C39	6C39H	8G49	8G49H	12H36	12H35H
6F38	6F39H	8H28	8H29H	12P23	12P21H (2)
6F39	6F39H	8H29	8H29H	12P34	12P35H
6P38	6P39H	8P28	8P29H	12P35	12P35H
6P39	6P39H	8P29	8P29H	12P36	12P35H
6Z13	6Z13H	8P49	8P49H	12V43H	12V45H (2)
7A33, 7A33H	7A37H	8T25	8T25H	12Z23	12Z21H (2)
7A35, 7A35H	7A39H	9A33, 9A33H	9A37H	16B23	16B21H (2)
8A11	8A11H	9A35, 9A35H	9A39H	16G23	16G23H
8A13	8A11H (2)	10A13	10A11H (2)	16T23	16T21H (2)
8A22S	8A27S (2)	10A14	10A11H (2)	16T32H	16T31H (2)
8A24	8A25H	10A54	10A53H (1) (2)		

- (1) Unit changes to dual capacitor type.
- (2) Replacement unit requires different stator winding.

2.3B CATERPILLAR OEM PART NUMBERS – Follow specification for equivalent value.

CAT OEM NO.	EQUIVALENT	CAT OEM NO.	EQUIVALENT	CAT OEM NO.	EQUIVALENT
104-4510	6A39HT-A	328-8383	4A39H-A	7C-0753	16B21H-A
104-4511	6A29HT-AO	328-8385	6A39H-A	7C-8882	16V43HT-J-S2
104-4512	8A23HT-GO	328-8386	6A39HT-A	7E-6215	12V43HT-J-S2
104-4513	12P21HT-GO	4P-8903	12P21H-GO	7E-8245	6A46HT-J-S1
2W-3741	8T25H-A	4P-8904	8A23H-GO	7E-8246	8A45HT-J-S1
2W-3743	8A25H-G	4P-8905	6A29H-GO	7W-2171	12A23HT-J
2W-3746	4A29H-A	4W-8946	12A33H-A	7W-2172	16T21HT-J
2W-3749	6A39H-A	6I-2310	4A39H-A		

2.4 UNIT SPECIFICATIONS

See page 6 to determine mounting, gear ratio and stator winding from unit part number. Check discontinued part no. list on page 6 for numbers not listed. ALWAYS USE THE PART LISTED - DO NOT SUBSTITUTE.

- NOTES:
- 3818XX-XH back cover replaces prior type 3814XX-X.
Example: 381803-1 H replaces 381403-1.
 - For unit with electronic timing option, add "T" suffix to Back Cover part number.
Example: For 8A29HT, Back Cover no. Is 381803-1 HT.

UNIT NO.	(10) STATOR	BACK COVER	(51) CIRCUIT BOARD	(24) TIMER ARM	(28) MAGNET PLATE
2A19H	371604	381801-10H	373104H	370005	360418
2A29H	371604	381801-0H	373104H	370005	360418
3A29H	371604	381801-4H	373104H	370005	360407
4A29H	371604	381801-1H	373104H	370005	360418
4A39H	371604	381801-6H	373104H	370005	360418
4A49H	371604	381801-14H	373104H	370005	360418
4F29H	371604	381801-2H	373104H	370005	360408
4G29H	371604	381801-3H	373104H	370005	360429
5A59H	371604	381805-1H	373106H	370005	360424
6A17H	371602	381802-11H	373106H	370005	360407
6A17XS	371602	381802-11H	373106H	370005	360407
6A29H	371604	381802-2H	373106H	370005	360407
6A37S	371602	381802-1H	373106H	370005	360407
6A39H	371604	381802-1H	373106H	370005	360407
6A46H	371604	381807-11H	373109H	370005	360407
6A69H	371604	381802-7H	373106H	370005	360407
6B36H	371604	381807-6H	373208H	370005	360446
6B39H	371604	381802-3H	373106H	370005	360446
6C39H	371604	381802-6H	373106H	370005	360436
6F39H	371604	381802-4H	373106H	370005	360430
6F69H	371604	381802-8H	373106H	370005	360430
6P39H	371604	381802-5H	373106H	370005	360433
6Z13H	371602	381807-4H	373208H	370005	360447
7A37H	371602	381810-4H	373109H	370005	360442

2.4 UNIT SPECIFICATIONS (continued)

UNIT NO.	(10) STATOR	BACK COVER	(51) CIRCUIT BOARD	(24) TIMER ARM	(28) MAGNET PLATE
7A39H	371604	381810-4H	373109H	370005	360442
8A11H	371601	381803-13H	373208H	370005	360419
8A12XS	371601	381803-21H	373108H	370005	360419
8A23H	371602	381803-5H	373208H	370005	360419
8A25H	371604	381803-5H	373208H	370005	360419
8A27S	371602	381803-1H	373108H	370005	360419
8A29H	371604	381803-1H	373108H	370005	360419
8A37H	371602	381803-9H	373109H	370005	360419
8A39H	371604	381803-9H	373109H	370005	360419
8A45H	371604	381803-25H	373208H	370005	360419
8A49H	371604	381803-24H	373108H	370005	360419
8B13H	371602	381803-14H	373208H	370005	360429
8B25H	371604	381803-6H	373208H	370005	360429
8B29H	371604	381803-3H	373108H	370005	360429
8B35H	371604	381803-23H	373208H	370005	360429
8C25H	371604	381803-7H	373208H	370005	360409
8E29H	371604	381803-12H	373108H	370005	360439
8E49H	371604	381803-124H	373108H	370005	360439
8F25H	371604	381803-10H	373208H	370005	360432
8G29H	371604	381803-4H	373108H	370005	360428
8G49H	371604	381803-44H	373108H	370005	360428
8H29H	371604	381803-8H	373108H	370005	360431
8J63H	371602	381813-1H	373208H	370813-1	360455
8L63H	371602	381803-16H	373208H	370005	360449
8P29H	371604	381803-11H	373108H	370005	360434
8P49H	371604	381803-114H	373108H	370005	360434
8T25H	371604	381803-20H	373208H	370005	360429
9A37H	371602	381811-1H	373109H	370005	360450
9A39H	371604	381811-1H	373109H	370005	360450
10A11H	371601	381806-2H	373212H	370005	360424
10A11XS	371601	381806-2H	373212H	370005	360424
10A51S	371601	381806-3H	373212H	370005	360424
10A53H	371602	381806-3H	373212H	370005	360424
10D55H	371604	381814-1 H	373212H	370814-1	360462
10E55H	371604	381814-2H	373212H	370814-2	360462
10H11H	371601	381806-5H	373212H	370005	360464
10P55H	371604	381814-3H	373212H	370814-3	360462
10T53H	371602	381814-4H	373212H	370814-4	360462
12A11XS	371601	381804-21H	373212H	370005	360406
12A21H	371601	381804-2H	373212H	370005	360406
12A23H	371602	381804-2H	373212H	370005	360406
12A25H	371604	381804-2H	373212H	370005	360406

2.4 UNIT SPECIFICATIONS (continued)

UNIT NO.	(10) STATOR	BACK COVER	(51) CIRCUIT BOARD	(24) TIMER ARM	(28) MAGNET PLATE
12A31S	371601	381804-6H	373212H	370005	360406
12A33H	371602	381804-6H	373212H	370005	360406
12A35H	371604	381804-6H	373212H	370005	360406
12B11H	371601	381812-51H	373212H	370812-51	360456
12B33H	371602	381812-5H	373212H	370812-5	360456
12C45H	371604	381804-20H	373212H	370804-20	360436
12D35H	371604	381804-7H	373212H	370005	360435
12E11H	371601	381812-11H	373212H	370812-11	360456
12E23H	371602	381812-2H	373212H	370812-2	360456
12E33H	371602	381812-1H	373212H	370812-1	360456
12E53H	371602	381812-3H	373212H	370812-3	360456
12F33H	371602	381804-18H	373212H	370005	360452
12G11H	371601	381804-12H	373212H	370005	360452
12H35H	371604	381804-9H	373212H	370005	360436
12J33H	371602	381804-8H	373212H	370005	360451
12K33H	371602	381804-14H	373212H	370005	360463
12P21H	371601	381804-11H	373212H	370005	360457
12P35H	371604	381804-10H	373212H	370005	360457
12T23H	371602	381812-9H	373212H	370812-9	360456
12T33H	371602	381812-10H	373212H	370812-10	360456
12V33H	371602	381804-19H	373212H	370005	360451
12V45H	371604	381804-16H	373212H	370005	360451
12Z21H	371601	381812-8H	373212H	370812-8	360456
16B21H	371601	381809-3H	373216H	370809-3	360458
16C33	371602	381809-9H	373216H	370809-9	360458
16F21H	371601	381809-13H	373216H	370809-13	360458
16G23	371602	381809-6H	373216H	370809-6	360458
16G33H	371602	381809-7H	373216H	370809-7	360458
16J31	371601	381809-8H	373216H	370809-8	360458
16K33H	371602	381809-10H	373216H	370809-10	360458
16M21	371601	381809-12H	373216H	370809-12	360458
16P21H	371601	381809-17H	373216H	370809-17	360458
16P31H	371601	381809-16H	373216H	370809-16	360458
16T21H	371601	381809-5H	373216H	370809-5	360458
16T31H	371601	381809-18H	373216H	370809-18	360458
16V43H	371602	381809-14H	373216H	370809-14	360458
16W31H	371601	381809-15H	373216H	370809-15	360458

2.5 CIRCUIT BOARD ASSEMBLY (51)

- A. 373xxxH replaces all prior types: 37240x, 37250x, 37260x, 37266x, 37270x, 37277x, 37280x, and 3729xxH. To insure use of the proper part number circuit board, refer to the discontinued part no. list on page 7 and then the listing of current units on pages 8-10.
- B. It is recommended that all prior types of circuit boards be returned to the factory for exchange to type 373xxxH whenever a unit is being serviced.
- C. IMPORTANT NOTE: When replacing former 12-output circuit boards with SINGLE storage capacitors with type 373212H, the note regarding recalibration of ignition-powered tachometers and/or overspeed devices must accompany the unit to the end user. If the tachometer and/or overspeed device is not recalibrated, the new circuit board will cause incorrect (one-half) readings; this condition could lead to improper engine operation and pose the threat of personal injury to operators or other nearby personnel.

2.6 CONNECTION SPECIFICATIONS

- A. Wiring Color Code - Connector (51c)

3 to 12 Cylinders:		16 Cylinders:	
G	orange	G	orange
N	black	all others all others	white
all others all others	white		

- B. Connection Sequence - Pickup Coils (31): "A" pickup coil is indicated in RED: "B", "C", "D", etc. follow consecutively in CW direction from "A".

2.7 BEARING FIT TOLERANCES:

A. Housing Bearing Bores:	Front Housing (6)	1.5737"/1.5739"
	Intermediate Housing (13)	1.865"/1.867"
	Back Cover (58)	1.1800"/1.1803"
B. Shaft Bearing Diameter:	Drive Shaft (7)	.6693"/.6696"

3.0 PERFORMANCE SPECIFICATIONS

Install unit on a test stand equipped with a suitable number of 501061 coils and spark gaps. Test stand wiring should conform to that shown in the Installation Instructions form AIII II.

3.1 VOLTAGE TEST

- A. With the wiring harness unplugged, measure the positive voltage at the connector "G" pin:

UNIT SPEED	CIRCUIT BOARD NO.	VOLTAGE OUTPUT
70 rpm	Any	60 VDC min.
500 rpm	Any	200-220 VDC

3.2 OPERATING TEST

- A. At 70-90 RPM a 7mm gap should fire consistently.
- B. At the TEST RPM (see pages 12-15) a 15mm gap should fire consistently.

3.3 TIMING SPECIFICATIONS

- A. The Altronic III units are listed on pages 12-15. Establish the indicated TEST RPM and ROTATION.
- B. Check the Firing Degree Sequence as indicated. The basic tolerance is \pm one (1) distributor degree. This must be multiplied by the internal gear ratio since the degrees are read at the unit drive shaft speed.
- C. If timing is out of specification, change the pickup coil (31) in question.

4.0 TROUBLESHOOTING

4.1 CIRCUIT DIAGRAM

- A. The diagram below shows the Altronic III circuit for one cylinder. Each component in the Timing-Distribution section (to the right of the dashed line) is present in a quantity equal to the number of cylinders being served; each engine cylinder requires a pick-up coil assembly and TRIAC (TC1).
- B. The operation is as follows: The AC voltage generated by the alternator is converted to DC by the full wave rectifier (FWR) and stored in the energy storage capacitor (C1). The DC voltage level is regulated by a zener diode regulation circuit Z1 and Q2. Capacitor C2 is charged through resistor R1 to provide the energy to trigger TC1. This occurs when the rotating distributor arm passes a pickup coil (P) triggering on SCR 1 and connecting capacitor C2 through resistor R3 to the gate of TC1. TC1 then turns on discharging capacitor C1 into the primary of the ignition coil which steps up the voltage to fire the spark plug. Components Q1 and Q2 insure that TC1 turns off immediately after each discharge. Capacitors C2 and C3 act as filters to prevent crossfiring between cylinders.

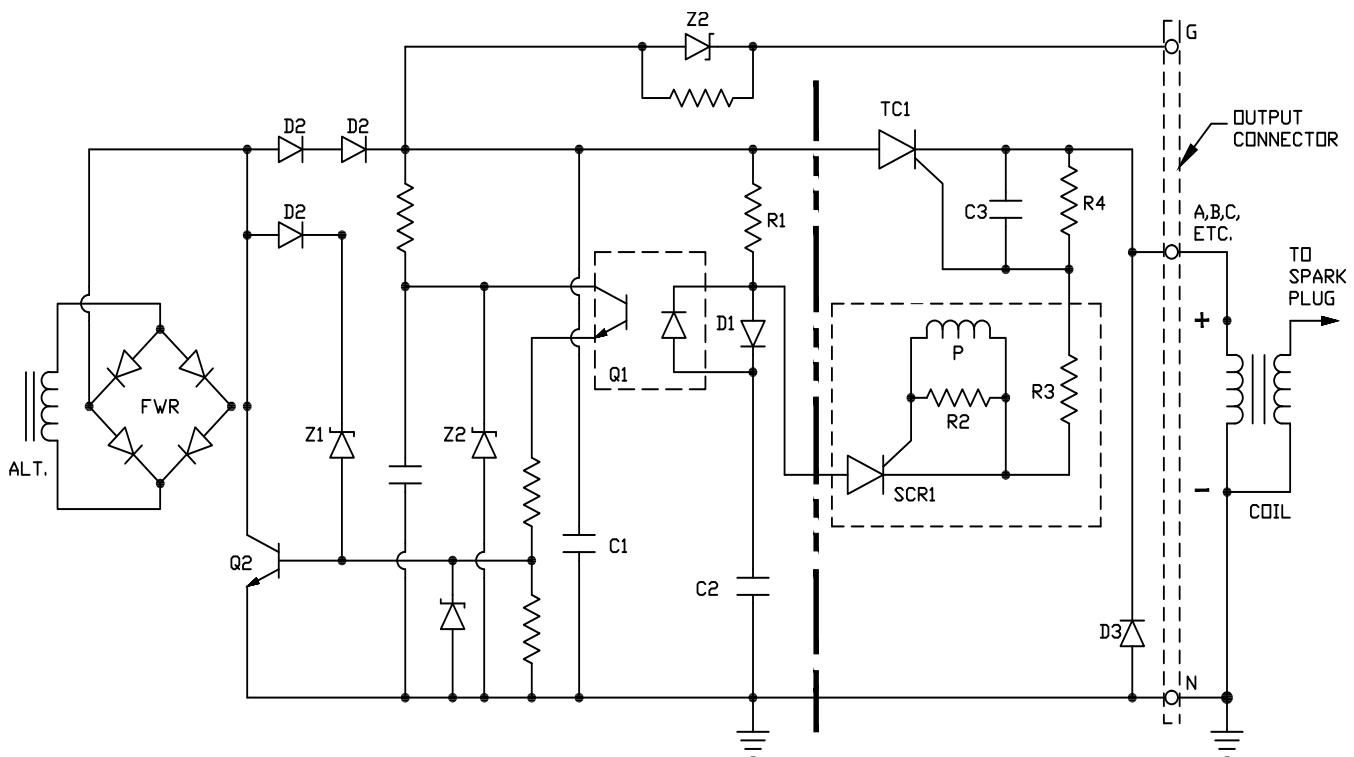

C. Components:

C1	Capacitor, energy storage
C2	Capacitor, trigger circuit
C3	Capacitor, TRIAC gate
D1	Diode, trigger circuit
D2	Diode, power
D3	Diode, recirculating
FWR	Full wave rectifier

Q1	Transistor, isolator
Q2	Transistor
R1	Resistor, trigger circuit
R4	Resistor SCR gate
SCR1,P,R2,R3	Pickup coil ass'y.
TC1	TRIAC
Z1	Zener diode, regulating
Z2	Zener diode, 51V

4.2 TROUBLESHOOTING GUIDE

- A. See Section 3.0 – 3.3 for proper electrical performance.
- B. The checks below should be made with a Simpson model 260 volt-ohmmeter or equivalent.
- A. “Connector pin” refers to the connector into which the wiring harness is plugged. “Circuit board pin connection” refers to the solid pins on the circuit board – see page 18.
- B. The 373xxxH, 3729xxH and 37280x series circuit boards require a different test hook-up for tests 1b and 2b below: they will always test defective if checked in accordance with prior Troubleshooting Guides.

PROBLEM		POSITIVE OHMMETER LEAD	NEGATIVE OHMMETER LEAD	SCALE	READING	REMEDY FOR FAULTY READING
1. One output not firing	a)	–	–	–	Check corresponding circuit board pin connection	Correct connection
	b)	Pickup coil common(s) (see page 20)	Connector pin of output not firing	R X 10,000	Move timer arm past pickup coil corresponding to test pin. Meter should flicker, indicating pickup output	Replace pickup coil (31)
	c)	–	–	–	If above checks are okay...	Replace circuit board ass’y. (51)
2. 8-12 cylinders: No output on every other output OR 4-6 cylinders No output but “G” lead has 100+ volts	a)	–	–	–	Check circuit board pin connections – pickup common(s)	Correct connection
	a)	Pin 1 and 2 (see page 20)	Connector pins	R X 10,000	Slight flicker in meter with final reading no lower than 500 X 10,000 (5 megohm)	Replace corresponding pickup coil (31)
	c)	–	–	–	If above checks are okay...	Replace circuit board ass’y. (51)
3. Weak or no output	a) Stator	Across 2-prong stator plug terminals		250VAC	Spin alternator coupling – 75 VAC	Replace stator (10)
	b) Stator	Across both stator terminals	Ground	R X 10,000	Infinite	Replace stator (10)
	c) Circuit Board	–	–	–	If above checks are okay...	Replace circuit board ass’y. (51)

4.3 OSCILLOSCOPE TESTING

The system should be fully connected per section 3.0 with the Altronic III unit operating at the TEST RPM given in section 3.2. Connect the oscilloscope probe to the “G” lead of the output connector. Set the oscilloscope vertical calibration to 50 volts/div.; adjust the time base to get a full cycle of firings on the screen: No. of discharges = number of outputs for single capacitor unit; half the number of outputs for dual capacitor unit.

A. STORAGE CAPACITOR PATTERN: NORMAL

The normal patterns for typical single (8A29H) and dual storage capacitor (12A33H) units are shown below.

NOTE: Patterns below apply to units having 373xxxH circuit board assembly.

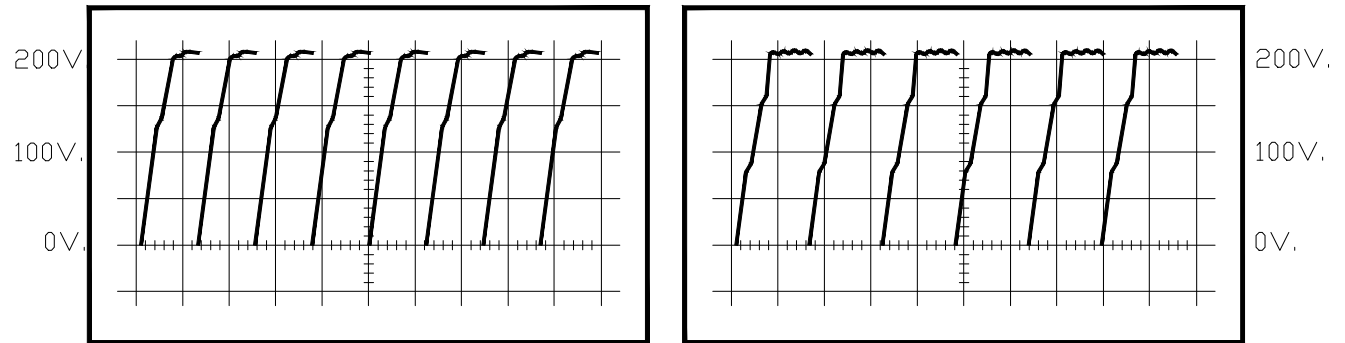

B. STORAGE CAPACITOR PATTERN: ABNORMAL

One cylinder misfiring. See troubleshooting section 4.2, no. 1.

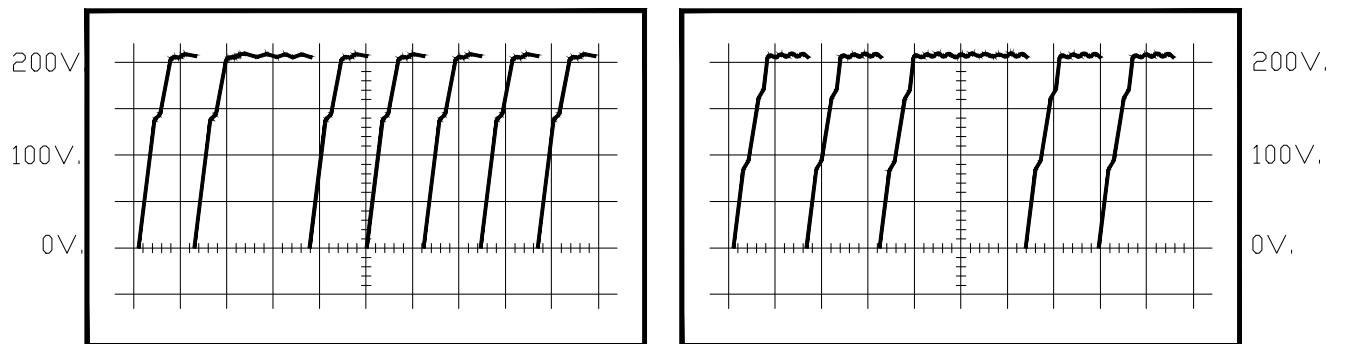

C. STORAGE CAPACITOR PATTERN: NORMAL

Stepped waveform. See troubleshooting section 4.2, no. 3.

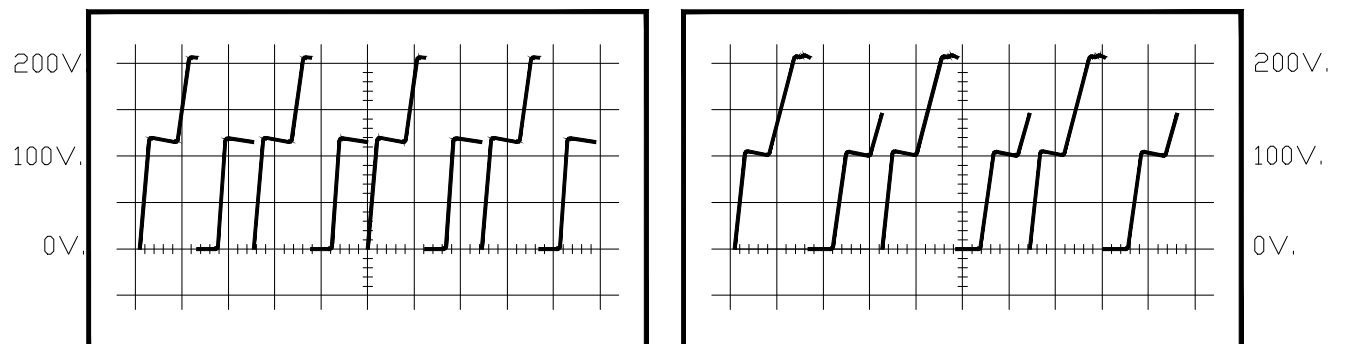

5.0 SERVICE – BACK COVER ASSEMBLY

The unit breaks down into two major parts: the Alternator Section and the Back Cover Assembly. Remove the four back cover attaching screws (34) and carefully pull the back cover assembly away from the the alternator housing; unplug the 2-prong internal connector..

5.1 CIRCUIT BOARD ASSEMBLY (51) – REPLACEMENT

- A. To remove the circuit board assembly, follow the steps below:
1. Remove two screws (43), washers (42) and two connector screws (40).
 2. Tilt board away from pickup coils and unplug all the leads from the pickup coil assembly to the circuit board connections.
NOTE: Pull the pickup connectors (39) straight back from the board to avoid splitting the connector receptacle (see FIG. 1).
 3. Pull circuit board assembly (51) — consisting of the circuit board and connector (51c) — from the back cover.
- B. Reverse the above steps when reinstalling the circuit board assembly to the back cover.
1. Insert the connector (51c) through the cover hole and secure with screws (40). Note that two washers (41) are used under the screws (40) with the 373xxxH circuit boards having 14 or 17 pin connectors; no washers are used on 7-pin connectors.
 2. Referring to FIG. 1, connect the pickup coil receptacles (39) to the circuit board — push straight onto the board pin and seat completely.
NOTE: Any receptacle that has a loose fit should be squeezed together slightly with needle-nosed pliers or replaced, to insure a tight fit.
 3. Secure the board with screws (43) and washers (42); center the plastic brace (50) between the circuit board and the upper magnet plate (28).

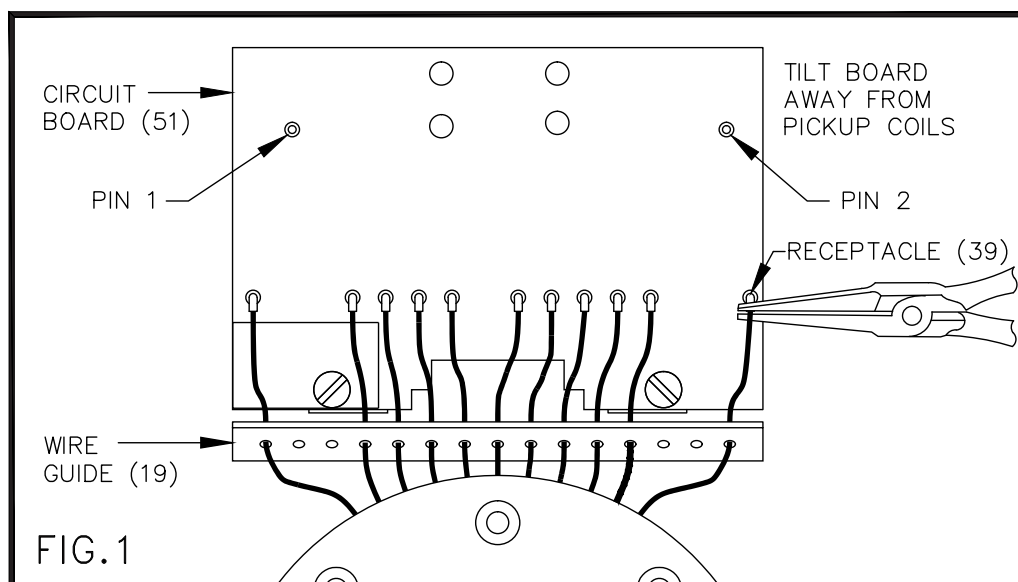

- C. Circuit Board Pin Connections (viewed from pickup coil side of board):

2-12 CYL:

○	○	○	○	○	○	○	○	○	○	○	○	○	○	○
Pickup	L	J	H	E	C	A	Grd	B	D	F	I	K	M	Pickup
Common														Common

16-CYL:

○	○	○	○	○	○	○	○	○	○	○	○	○	○	○	○	○		
Pickup	S	P	M	K	H	E	C	A	Grd	B	D	F	J	L	N	R	T	Pickup
Common																		Common

NOTE: Crimping tool for receptacle (39) is American Pamcor, Inc. Part No. 90204-1.

5.2 PICKUP COIL (31) – REPLACEMENT

- A. To change a pickup coil (31), first remove the nuts (33), screws (26), and magnet plate (28). Mark spacers (30) so that they can be reinstalled in the same position during reassembly.
- B. Cut the red and brown or black leads at the coil to be removed. Install new pickup coil with the end having the black line facing up. Solder the brown wire to the common lead and splice the red wire into the original line leading to the wire guide and receptacle. Use heat-shrinkable tubing over the spliced red wire connection; be sure that no connections touch ground.
NOTE: Do not mix black (351001) and white (351002) pickup coils in the same back cover: always replace with the same color that was removed.
- C. Reassemble spacers (30) and magnet plate (28) using hardware (26), (32) and (33).

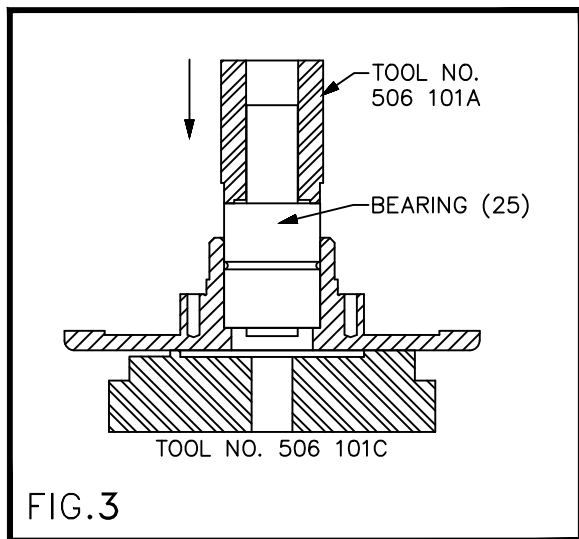
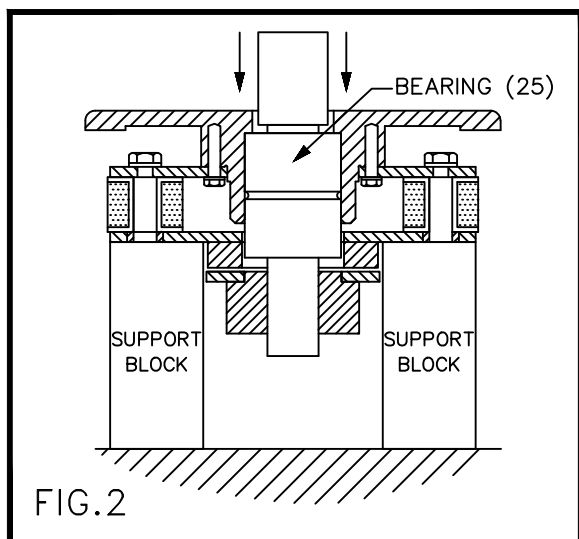

5.3 BEARING (25), TIMER ARM (24), DRIVEN GEAR (23) – REPLACEMENT

- A. The procedures of this section require the use of a small arbor press.
- B. Remove timing cover (36) and driven gear (23).
- C. Referring to FIG. 2, support upper pickup plate (28) on both sides of timer arm (24) and press timing mark end of distributor shaft (25) until bearing is pressed out of timing cover housing.
- D. Press bearing shaft (25) out of aluminum hub of timer arm assembly (24).
- E. Replace any worn or defective parts.
- F. Press a new bearing shaft (25) into the back cover housing until it bottoms. Referring to FIG. 3, the cover should be supported around the timing access hole using tool no. 506101C. Press on the outer race of the bearing with tool no. 506101A.
- G. Thoroughly clean all filings, dirt, etc., from the top exposed face of magnet (28). Also clean the surface of pickup arm assembly (24) that will come in close proximity to the magnet.
- H. Support the end of the shaft (25) using tool no. 506104D until the gap between the pickup arm and the pickup coil cores is $.010'' - .018''$ (see FIG. 4). At this point, the timer arm (24) **MUST ROTATE FREELY** the full 360 degrees of rotation. If there is any interference, the bearing shaft assembly must be removed from the cover (see step 5.3C.) and steps 5.3D. through 5.3H. must be repeated until the pickup arm rotates freely with a gap not exceeding $.018''$.
- I. Install driven gear (23) on shaft; if worn, use new gear. Use new lockwashers (22) and tighten four screws (21) securely.
- J. With timer arm (24) centered over the core of pickup coil "A" (red), the shaft timing mark (27) should be set midway between the CCW and CW marks of the decal (35). Timing labels should be clean.
- K. Replace timing cover (36) and secure with two screws (37).
- L. Install a new cover gasket (29).

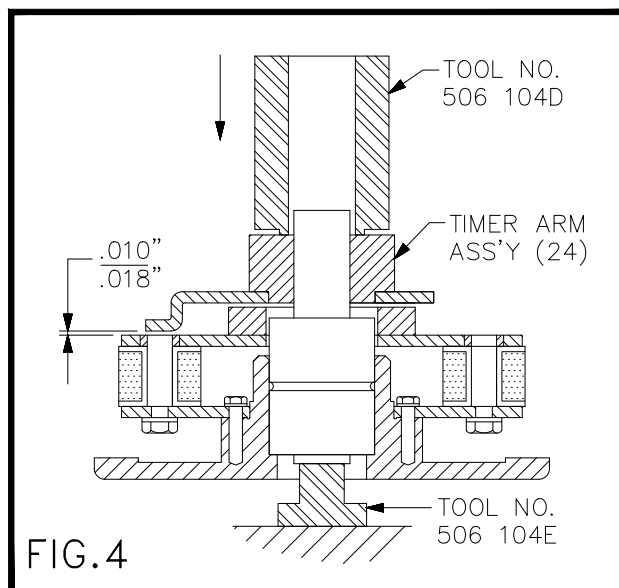

6.0 SERVICE – ALTERNATOR SECTION

- A. Replace all worn or defective parts.
- B. The procedures of this section require the use of a small arbor press.

6.1 DISASSEMBLY – COUPLING (1) OR (2)

- A. Drive spring pin (1a) or (2a) out of coupling (1) or (2) and shaft (7) and remove coupling from shaft.

6.2 DISASSEMBLY – FLANGE MOUNT UNIT

- A. Unscrew four screws (11) and remove flange (3) from housing (5). Note the relationship of flange to housing so that it may be reinstalled in the same position.

6.3 DISASSEMBLY – STATOR (10)

- A. Release the stator leads from clamp (17).
- B. Remove three screws (48) holding the alternator assembly together.
- C. Using a plastic or rubber hammer, tap intermediate housing (13) away from stator and front housing until free from bearing cover (9).
- D. Pull stator winding (10) and seal band (10a) free from housing (5) taking care not to damage Teflon® wrapping.

6.4 DISASSEMBLY – BEARINGS (6)

- A. Remove drive gear (16), then reinstall screw (20) in shaft.
- B. Remove rubber bearing cover (9). Use small bearing puller to remove gear end bearing (6).
- C. Referring to FIG. 5, support front housing (5) on the stator end. Using an arbor press, press on drive end of the main shaft until shaft assembly (7) is free from the front housing (5).
- D. Press the drive end bearing (6) from either housing (5) or shaft (7).

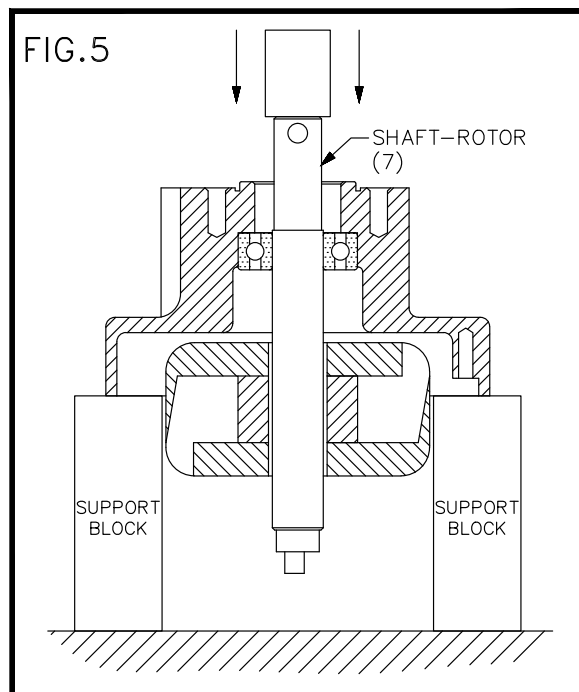

6.5 PARTS REPLACEMENT

- A. Replace gaskets (3b) and (4).
- B. Replace coupling (1 or 2), seal (3a), bearings (6) and bearing cover (9) with new parts.
- C. Replace any removed hardware with new parts.
- D. Aluminum housings should be cleaned in carbon tetrachloride or similar cleaning solution.
- E. Any metal filings should be cleaned from magnet-rotor (7) before reassembly.

6.6 REASSEMBLY – FRONT HOUSING ASSEMBLY

- A. Press new drive end bearing (6) into front housing (5) until it bottoms. Referring to FIG. 6, support the housing with tool 506105B; use the loose ring provided EXCEPT with adjustable base housing 360405. Press on the outer race of the bearing using tool 506105A.
- B. Referring to FIG. 7a, press the shaft-rotor assembly (7) into the front housing assembly (5). Use tool no. 506104A to press on the end of the shaft, and tool no. 506104C to support the inner race of the bearing. This will insure the correct extension of the shaft through the bearing (see FIG. 7a).
- C. Install bearing spacer (8) on shaft (see FIG. 7b).
- D. Press gear end bearing (6) on shaft (7) until it bottoms against the bearing spacer (8). Referring to FIG. 7b, leave tool no. 506104C (step 6.6B) in place to support the coupling end of the shaft. Press on the inner race of the bearing for this operation using tool no. 506104D.
- E. Install a new rubber bearing cover (9) on gear end bearing (6).
- F. Using a new lockwasher (32) and flat washer (18), install drive gear (16); if worn, use a new gear. Secure with screw (20).
- G. If the 360405 housing (-BEL) has been disassembled, use a lubricating grease on the mating surfaces and reinstall the large snap ring with its gap at the 3 o'clock position (90° from the base).

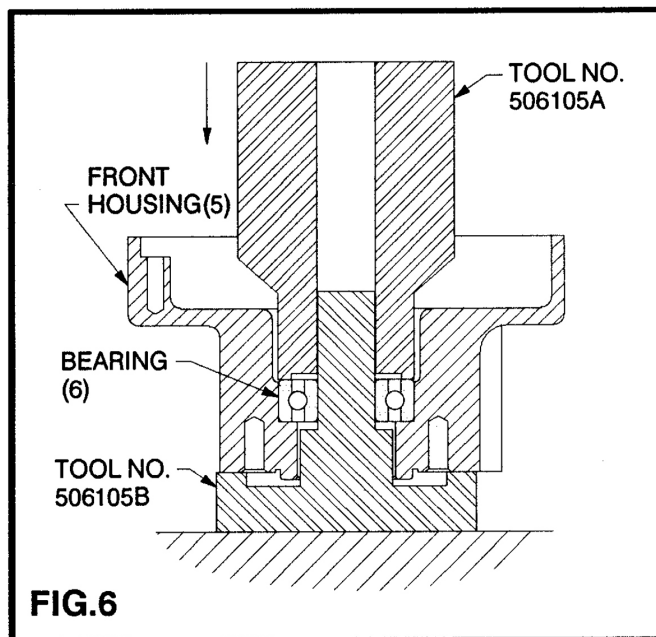

6.7 REASSEMBLY – ALTERNATOR

- A. Insert one 10-24 x 2-1/4" screw (48) through the stator hole, 180° from the stator leads and plug. Place stator (10) over rotor (7) so that the leads are on the same side as the flat base on housing (5). Use the screw to line up the stator holes properly with the tapped holes in the housing (5). Insert stator into front housing taking care not to damage the Teflon® wrapping or the windings. Remove screw.
- NOTE: Stator 371604 replaces previous types 371004 and 371007. The hole in housing (13) for the stator leads must be enlarged to .750" diameter in units below S/N 12,000.
- B. Apply a film of Vaseline® or similar lubricant to the bearing bore in intermediate housing (13). THIS IS ESSENTIAL FOR PROPER ASSEMBLY.
- C. Insert the stator plug and leads through the .750" dia. hole in housing (13) and start the housing over bearing cover (9). Insert three new HEX SOCKET HEAD SCREWS (48) – DO NOT REUSE THE OLD SCREWS – and lockwashers (47) through housing (13) and stator (10) into the tapped holes in the front housing (5). Apply pressure evenly to bring housings (13) and (5) together over the stator. Take care not to damage the Teflon® wrapping on the stator core. Using a torque wrench, tighten the three screws (48) evenly in several steps to a final torque of 78 in.-lbs. (6.5 ft.-lbs.).
- NOTE: This torque specification applies only to the hex socket head screws, part no. 902601. These should be used on all overhauls replacing the former filister head, slotted screw.
- D. At this point, the shaft should turn freely without mechanical drag. If there is mechanical interference (not to be confused with the magnetic drag of the 12-pole alternator), remove the intermediate housing (see steps 6.3B and 6.3C), and repeat steps 6.7B and 6.7C.
- E. Insert stator leads in clamp (17).
- NOTE: If clamp (17) has pulled loose from housing (13), use silicon rubber adhesive (503151) to secure clamp to housing.
- F. Install a stator seal band (10a) from the coupling end. The band should seat against the stator (10) between housings (5) and (13).

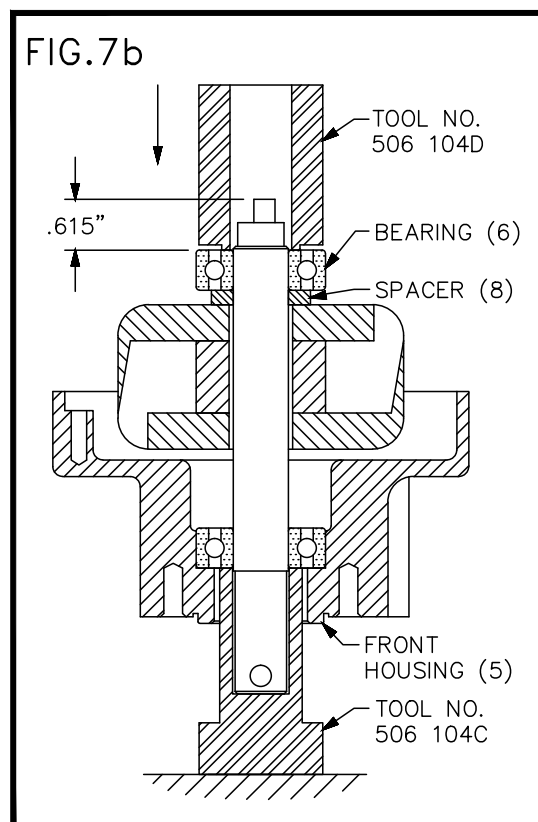
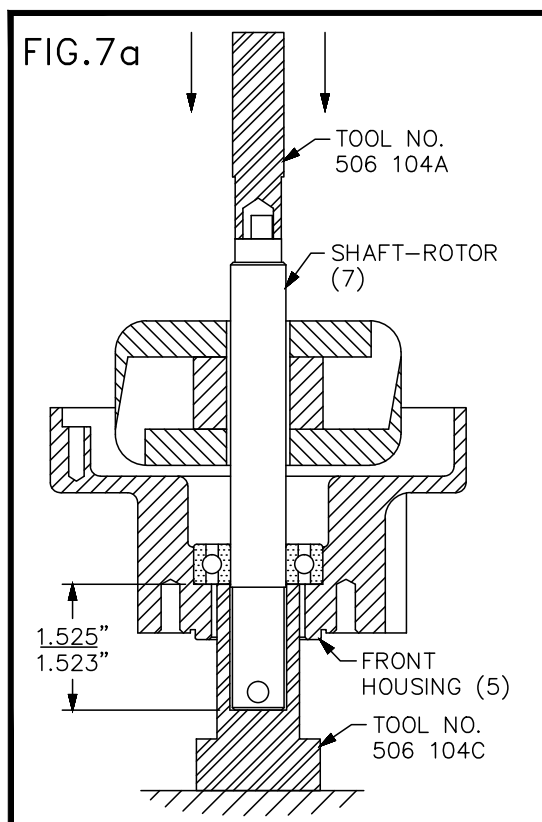

6.8 FLANGE MOUNT UNIT

- A. Replace oil seals (3a) in flange bracket (3) Place new gasket (4) on housing (5).
- B. Install flange bracket (3) to housing (5) and insert four new screws (11) – DO NOT REUSE OLD SCREWS. Note whether nameplate on unit calls for a flange to be mounted vertically with tapped hole up (-A or -GV), or horizontally (-D or -G). Tighten screws (11) to 10-12 ft-lbs.
- C. Glue a new flange gasket (3b) to the unit flange.

6.9 COUPLING

- A. Install coupling (1) or (2) on shaft (7) lining up holes in coupling and shaft.
- B. Use tool no. 506108A to drive spring pin (1a) or (2a) through coupling and shaft until flush with the coupling O.D.

6.10 REASSEMBLY – BACK COVER TO ALTERNATOR

- A. The timing mark on the back cover should line up with the stationary rotation mark (CCW or CW) on the cover just as the leading edge of the trigger arm reaches the hole in the steel plate for “A” (red) pickup coil.
- B. For FLANGE MOUNT UNITS, mate the back cover to the alternator with both set as shown in FIG. 8 for the correct unit rotation. If the back cover mark does not line up exactly with the proper rotation mark with the coupling set as shown, rotate the alternator shaft 180° and try again. Obtain as close of a line-up as possible with the CCW or CW mark.
- C. Secure the back cover assembly to the alternator section with hardware (34) and (47).

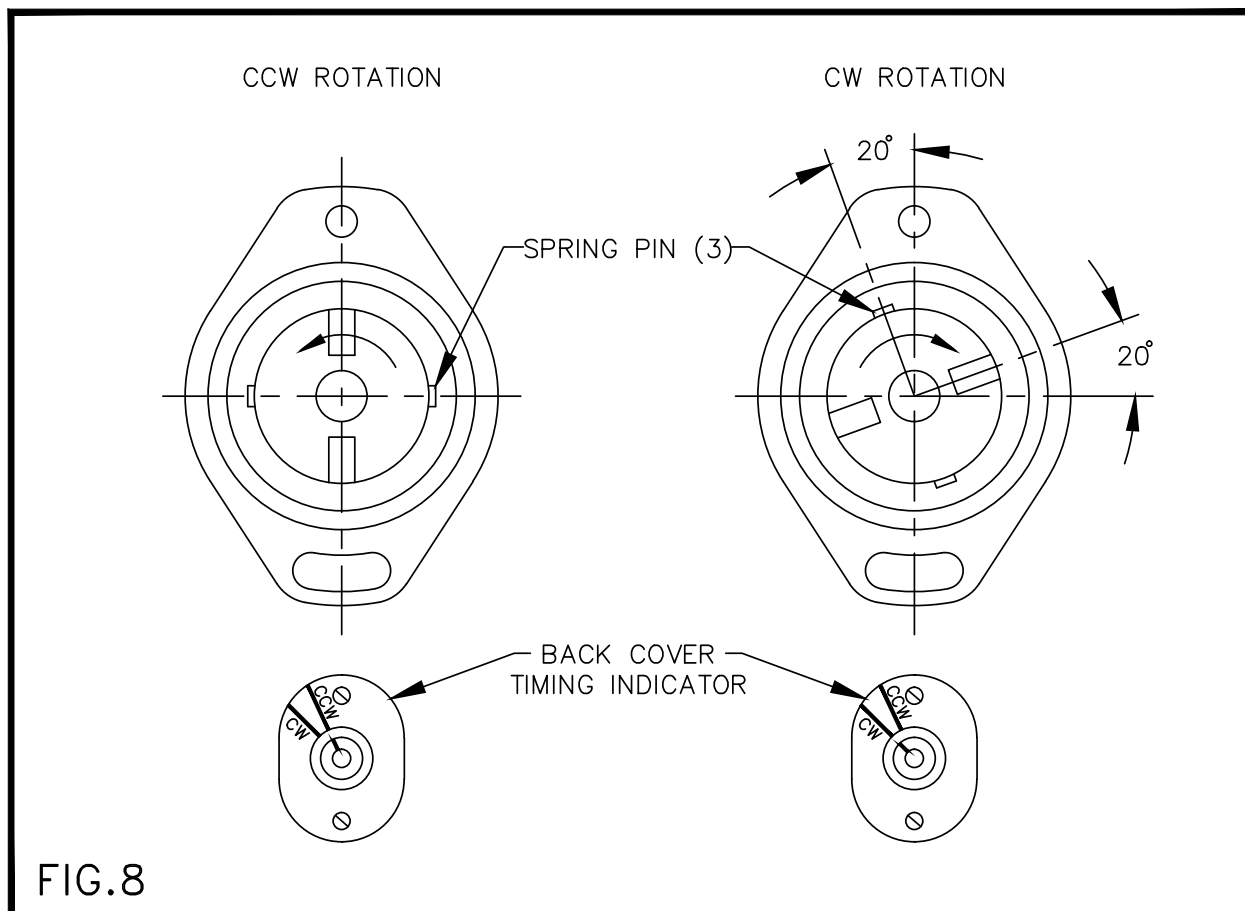

7.0 SERVICE – ASSEMBLY TOOLS

- A. The following assembly tools are referenced in sections 5.3, 6.6 and 6.9:
 - 506101A Press bearing-shaft (25) into back cover (58)
 - 506101C Support back cover (58)
 - 506104D Press timer arm assembly (24) on bearing-shaft (25)
 - 506104E Support bearing shaft (25)
 - 506105A Press bearing (6) into front housing (5)
 - 506105B Support front housing (5), including ring
 - 506104A Press shaft-rotor (7) into front housing (5)
 - 506104D Press gear-end bearing (6) on shaft-rotor (7)
 - 506104C Support front housing bearing (6)
 - 506108A Drive coupling pin (1a) or (2a) off and on

8.0 OPERATIONAL TEST

- A. Perform the tests following the guidelines in sections 3.0 through 3.3.
- B. Run the Operating Test in section 3.2B for one hour.
- C. After the one-hour Operating Test, check timing per section 3.3