

SIZE	mm	7	10	13	20	25	32	38	50
	in	1/4"	3/8"	1/2"	3/4"	1"	1-1/4"	1-1/2"	2"
d - Port	mm	10.0	10.0	12.7	19.0	25.0	31.8	38.0	48.0
	in	0.39	0.39	0.50	0.75	0.98	1.25	1.50	1.89
L end to end	mm	98.0	98.0	98.0	108.0	137.0	137.0	160.0	160.0
	in	3.86	3.86	3.86	4.25	5.39	5.39	6.30	6.30
l1 end to center	mm	49.0	49.0	49.0	52.5	68.5	68.5	81.0	80.0
	in	1.93	1.93	1.93	2.07	2.70	2.70	3.19	3.15
H	mm	59.0	59.0	59.0	66.3	72.5	97.8	131.0	139.0
	in	2.32	2.32	2.32	2.61	2.85	3.85	5.16	5.47
W	mm	145.0	145.0	145.0	190.0	190.0	220.0	255.0	410.0
	in	5.71	5.71	5.71	7.48	7.48	8.66	10.04	16.14
ISO flange number		F03	F03	F03	F04	F04	F05	F07	F07
BC threaded holes circle	mm	36.0	36.0	36.0	42.0	42.0	50.0	70.0	70.0
	in	1.42	1.42	1.42	1.65	1.65	1.97	2.76	2.76
NxM - number x size of threaded holes		4-M5	4-M5	4-M5	4-M5	4-M5	4-M6	4-M8	4-M8
Sd stem seal diameter	mm	10.0	10.0	10.0	12.0	16.0	16.0	20.0	24.0
	in	0.394	0.394	0.394	0.472	0.630	0.630	0.787	0.945
Sf stem flat	mm	6.0	6.0	6.0	7.0	10.0	10.0	12.0	15.0
	in	0.236	0.236	0.236	0.276	0.394	0.394	0.472	0.591
thd stem thread size	mm	M10x1.5	M10x1.5	M10x1.5	M12x1.75	M16x2	M16x2	M20x2.5	M24x3
	mm	10.0	10.0	10.0	12.0	16.0	16.0	20.0	24.0
	in	0.394	0.394	0.394	0.472	0.630	0.630	0.787	0.945
h	mm	10.0	10.0	10.0	14.0	14.0	20.0	28.6	28.6
	in	0.39	0.39	0.39	0.55	0.55	0.79	1.13	1.13
h3	mm	41.1	41.1	41.1	54.4	60.7	66.7	92.3	99.9
	in	1.62	1.62	1.62	2.14	2.39	2.63	3.63	3.93
h4	mm	27.0	27.0	27.0	33.0	38.3	43.0	57.3	64.8
	in	1.06	1.06	1.06	1.30	1.51	1.69	2.26	2.55
lt	mm	3.0	3.0	3.0	4.0	6.0	6.0	8.0	12.0
	in	0.12	0.12	0.12	0.16	0.24	0.24	0.31	0.47
BTO at 3000 maximum pressure	NxM	15.0	15.0	15.0	22.0	40.0	55.0	90.0	140.0
	INxLBS	132.8	132.8	132.8	194.7	354.0	486.8	796.6	1239.1

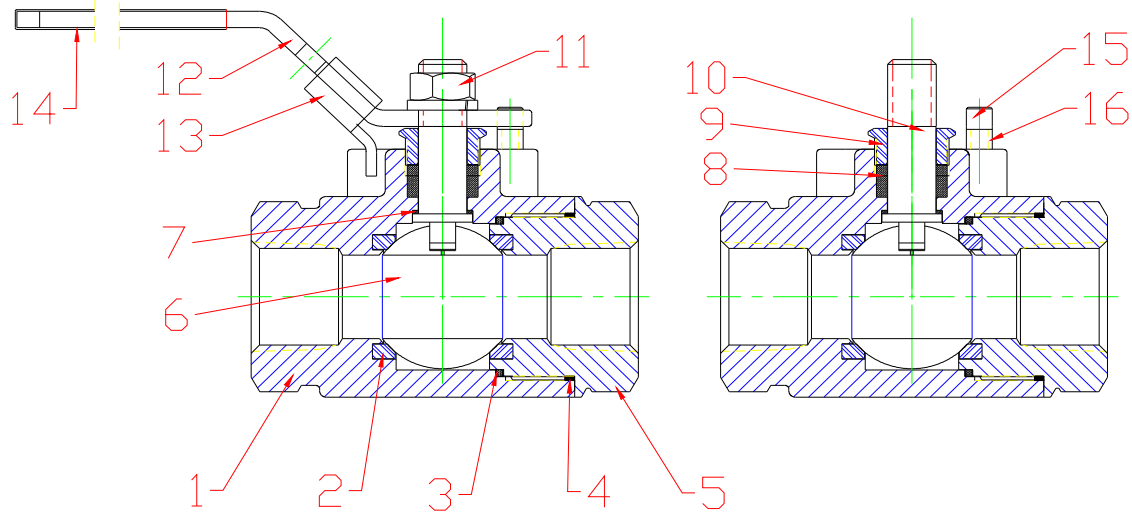

### B3 MATERIAL LIST

ITEM	PART	MATERIAL CS BODY OPTION	MATERIAL SS BODY OPTION
1	BODY	WCB CS	CF8M-SS
2	SEAT		DELRIN
3	BODY O-RING		VITON
4	BODY GASCKET		GRAPHITE
5	ADAPTER	WCB CS	CF8M-SS
6	BALL		316 SS
7	STEM THRUST WASHER		DELRIN
8	STEM PACKING		GRAPHITE
9	PACKING GLAND		304 SS
10	STEM		316 SS
11	STEM NUT		A2-70
12	HANDLE		201SS (1/4 to 1") CS (1-1/4 to 2")
13	LOCKING DEVICE		201SS (1/4 to 1") CS (1-1/4 to 2")
14	HANDLE GRIP		PVC
15	STOP CAP SCREW		A2-70
16	CAP SCREW		201 SS