



FOREWORD

This Arctic Cat Service Manual contains service, maintenance, and troubleshooting information for the 2012 Arctic Cat 700 Diesel SD ATV. The complete manual is designed to aid service personnel in service-oriented applications.

When using this manual as a guide, the technician should use discretion as to how much disassembly is needed to correct any given condition.

The service technician should become familiar with the operation and construction of each component or system by carefully studying the complete manual. This manual will assist the service technician in becoming more aware of and efficient with servicing procedures. Such efficiency not only helps build consumer confidence but also saves time and labor.

All Arctic Cat ATV publications and decals display specific symbols to emphasize important information. The symbol  **WARNING** identifies personal safety-related information. Be sure to follow the directive because it deals with the possibility of severe personal injury or even death. A **CAUTION** identifies unsafe practices which may result in ATV-related damage. Follow the directive because it deals with the possibility of damaging part or parts of the ATV. The symbol  **NOTE:** identifies supplementary information worthy of particular attention. The symbol  **AT THIS POINT** directs the technician to certain and specific procedures to promote efficiency and to improve clarity.

At the time of publication, all information, photographs, and illustrations were technically correct. Some photographs used in this manual are used for clarity purposes only and are not designed to depict actual conditions. Because Arctic Cat Inc. constantly refines and improves its products, no retroactive obligation is incurred.

All materials and specifications are subject to change without notice.

Keep this manual accessible in the shop area for reference.

**Product Service and
Warranty Department
Arctic Cat Inc.**

TABLE OF CONTENTS

Note: To navigate through this manual, use the PAGE UP/PAGE DOWN buttons on the keyboard, click on the Table of Contents bookmarks on the left side of the screen, or click the blue text below. To return to this page, click the Manual Table of Contents button at the bottom of each page.

General Information	2	Accessory Receptacle/Connector	101
General Specifications	2	Brakelight Switch (Auxiliary)	101
Torque Specifications	2	Brakelight Switch (Handlebar Control)	102
Torque Conversions (ft-lb/N-m)	4	Cooling Fan Switch	102
Break-In Procedure	4	Engine Coolant Temperature (ECT) Switch/ Thermistor	103
Fuel - Oil - Lubricant	4	Glow Plug Controller/Relay	103
Genuine Parts	5	Fan Motor	104
Preparation For Storage	5	Fuse Block/Power Distribution Module	104
Preparation After Storage	5	Speed Sensor	105
Periodic Maintenance/Tune-Up	7	Ignition Switch	105
Periodic Maintenance Chart	7	Handlebar Control Switches	106
Air Filter	8	Drive Select Switch	106
Valve Clearance	9	Front Drive/Differential Lock Actuator	107
Muffler/Spark Arrester	9	Starter/Starter Solenoid	107
Adjusting Throttle Cable	9	Starter Relay	108
Engine RPM (Idle)	10	Alternator/Regulator	108
Engine Oil - Filter	10	Headlights	109
Transmission Lubricant	11	Taillight - Brakelight	110
Front Differential/Rear Drive Lubricant	11	Fuel Solenoid	110
Tires	12	Troubleshooting	111
Driveshaft/Coupling	12	Drive System/Brake System	112
Injector Timing	12	Front Drive Actuator	112
Lights	12	Front Differential	113
Shift Lever	13	Drive Axles	126
Frame/Welds/Racks	14	Rear Gear Case	128
Hydraulic Brake Systems	14	Hub	129
Burnishing Brake Pads	15	Hydraulic Brake Caliper	130
Coolant	16	Troubleshooting Drive System	133
Checking/Replacing V-Belt	16	Troubleshooting Brake System	134
Fuel Filter	18	Suspension	135
Engine/Transmission	19	Shock Absorbers	135
Removing Engine/Transmission	20	Front A-Arms	136
Top-Side Components	24	Rear A-Arms	138
Left-Side Components	52	Wheels and Tires	139
Right-Side Components	58	Troubleshooting	141
Center Components	73	Steering/Frame/Controls	142
Installing Engine/Transmission	86	Steering Post/Tie Rods	142
Troubleshooting	92	Handlebar Grip	144
Fuel/Lubrication/Cooling	94	Hand Brake Lever/Master Cylinder Assembly	144
Diesel Fuel Injection System	94	Throttle Control	145
Lift Pump	94	Shift Lever	146
Unit Injectors	95	LCD Gauge	146
Injector Timing	95	Steering Knuckles	147
Fuel Filter	95	Measuring/Adjusting Toe-In	148
Fuel Solenoid Assembly	95	Front Rack	150
Fuel Tank	96	Front Bumper Assembly	150
Fuel/Vent Hoses	96	Front Body Panel/Side Panels	150
Oil Filter/Oil Pump	96	Footrests	153
Testing Oil Pump Pressure	97	Belly Panel	153
Liquid Cooling System	97	Exhaust System	153
Radiator	97	Rear Body Panel/Rack	154
Hoses/Thermostat	98	Adjusting Headlight	155
Fan	99	Taillight Assembly	155
Water Pump	99	Seat	155
Troubleshooting	99	Troubleshooting	156
Electrical System	100		
Battery	100		
Testing Electrical Components	101		
Switches	101		

7C Diesel SD

General Information

■NOTE: Some photographs and illustrations used in this section are used for clarity purposes only and are not designed to depict actual conditions.

General Specifications

FUEL INJECTION	
Type	Lombardini Unit Injectors
Idle RPM (engine warm)	800-900
Throttle Cable Free-Play (at lever)	1/4 in.
ELECTRICAL	
Glow Plug Type	Lombardini
Alternator	Denso 12V/40 Amp
CHASSIS	
Brake Type	Hydraulic w/Brake Lever Lock and Auxiliary Brake
Tire Size	Front - 25 x 8-12 Rear - 25 x 10-12
Tire Inflation Pressure	0.35 kg/cm ² (5 psi)
MISCELLANY	
Fuel Tank Capacity	20.81 L (5.5 U.S. gal.)
Coolant Capacity	5.6 L (5.9 U.S. qt)
Front Differential Capacity	275 ml (9.3 fl oz)*
Rear Drive Capacity	250 ml (8.5 fl oz)*
Engine Oil Capacity (with filter)	2.0 L (2.1 U.S. qt)
Engine Oil Capacity (without filter)	1.9 L (2.0 U.S. qt)
Transmission Capacity	600 ml (20.3 fl oz)
Fuel (recommended)	Biodiesel Blend up to 20% (B20)/42-50 Cetane Diesel - #1 or #2/JP 5 or JP 8 Turbine
Engine Oil (recommended)	SAE 10W-40
Differential/Rear Drive Lubricant	SAE Approved 80W-90 Hypoid
Transmission Lubricant	SAE Approved 80W-90 Hypoid
Drive Belt Width (minimum)	31.25 mm (1.23 in.)
Brake Fluid	DOT 4
Taillight/Brakelight	12V/8W/27W
Headlight	12V/27W (2)
VALVES AND GUIDES	
Valve Face Diameter (intake)	34.4 mm (1.35 in.)
(exhaust)	30.2 mm (1.19 in.)
Valve Clearance (cold engine) (intake/exhaust)	0.20 mm (0.008 in.)
Valve Guide/Stem Clearance	0.015-0.060 mm (0.0006-0.0024 in.)
Valve Guide Inside Diameter	7.005-7.020 mm (0.2758-0.2764 in.)
Valve Stem Diameter	6.960-6.990 mm (0.2740-0.2752 in.)
Valve Face/Seat Width (intake/exhaust)	1.6-2.0 mm (0.063-0.079 in.)
Valve Spring Free Length (min)	43.0 mm (1.69 in.)

Specifications subject to change without notice.

* Visible at plug threads.

CYLINDER, PISTON, AND RINGS	
Bore x Stroke	75 x 77.6 mm (2.95 x 3.05 in.)
Piston Ring End Gap - Installed (min)	0.25 mm (0.0098 in.)
Piston Ring Groove Width (1st)	0.090-0.125 mm (0.0035-0.0049 in.)
(2nd)	0.050-0.085 mm (0.0020-0.0033 in.)
(3rd)	0.040-0.075 mm (0.0016-0.0030 in.)
Piston Pin Bore (max)	18.025 mm (0.7096 in.)
Piston Pin Outside Diameter (min)	17.996 mm (0.7085 in.)
CAMSHAFT AND CYLINDER HEAD	
Camshaft Lobe Height (intake/exhaust) (min)	29.498 mm (1.161 in.)
Camshaft Injection Lobe (min)	28.848 mm (1.136 in.)
Camshaft Journal Holder Inside Diameter (max)	37.060 mm (1.459 in.)
Camshaft Journal Diameter (min)	36.975 mm (1.456 in.)
Cylinder Head Distortion (max)	0.10 mm (0.004 in.)
Rocker Arm Bore	18.015-18.030 mm (0.7092-0.7098 in.)
Rocker Arm Shaft	17.989-18.000 mm (0.7082-0.7087 in.)
CRANKSHAFT	
Connecting Rod Piston Pin Bushing (inside diameter) (max)	18.025 mm (0.7096 in.)
Crankshaft Main Bearing Journal	51.023-51.059 mm (2.009-2.010 in.)
Crankshaft Connecting Rod Journal(min)	39.9 mm (1.57 in.)
Connecting Rod Clearance	0.021-0.066 mm (0.0008-0.0026 in.)
Main Bearing Clearance	0.023-0.078 mm (0.0009-0.0031 in.)
Rod Bearing Diameter	40.021-40.050 mm (1.5756-1.5767 in.)
Oil Pump Pressure at 120° C (248° F) @ 900 RPM (min)	1.1 kg/cm ² (15.6 psi)
Cooling Fan Thermo-Switch (off→on)	93° C (199° F)
Operating Temperature (on→off)	87° C (189° F)

Torque Specifications

STEERING COMPONENTS			
Part	Part Bolted To	Torque	
		ft-lb	N-m
Handlebar Cap	Steering Post	20	27
Steering Post Bearing Housing	Frame	20	27
Steering Post Bearing Flange	Frame	20	27
Tie Rod End	Knuckle/Steering Post	30	41
EXHAUST COMPONENTS			
Exhaust Pipe	Exhaust Manifold	14	19
Spark Arrester	Muffler	48 in.-lb	5
BRAKE COMPONENTS			
Brake Disc***	Hub	15	19
Brake Hose	Caliper	20	27
Brake Hose	Master Cylinder	20	27
Brake Hose	Auxiliary Brake Cylinder	20	27
Auxiliary Brake Pedal	Lever Axle	25	34
Caliper Holder	Knuckle	20	27
Auxiliary/Hydraulic Caliper****	Knuckle	20	27

DRIVE TRAIN COMPONENTS			
Part	Part Bolted To	Torque ft-lb N-m	
Front Mounting Bracket	Engine	20	27
Engine Mount (Upper)**	Frame	35	48
Engine Mount (Front/Rear)	Frame	20	27
Front Differential***	Frame/Differential Bracket	38	52
Rear Drive Gear Case	Frame	38	52
Input Housing	Gear Case Housing	23	31
Output Drive Yoke Nut*	Output Shaft	72	98
Differential Housing Cover**	Differential Housing	23	31
Drive Bevel Gear Retaining Nut**	Secondary Output Shaft	87	118
Secondary Drive/Bevel Gear Shaft	Transmission Case	80	108
Pinion Housing	Gear Case	25	34
Ring Gear/Thrust Button*	Gear Case	8	11
Gear Case Cover	Gear Case	23	31
Lock Collar	Differential Housing	125	170
Hub Nut	Shaft/Axle (min)	200	272
Drain Plug	Front Differential/Rear Drive	42 in.-lb	5
Fill Plug	Front Differential/Rear Drive	16	22
Oil Drain Plug	Engine	18	24
Wheel (Steel)	Hub	45	61
Wheel (Aluminum)	Hub	80	108
CHASSIS COMPONENTS			
Shift Lever***	Shift Axle	8	11
ELECTRICAL COMPONENTS			
Ground Wire	Transmission	8	11
SUSPENSION COMPONENTS (Rear)			
A-Arm	Frame	50	68
Shock Absorber (Upper)	Frame	50	68
Shock Absorber (Lower)	Lower A-Arm	20	27
Knuckle	A-Arm	50	68
SUSPENSION COMPONENTS (Front)			
A-Arm	Frame	50	68
Ball Joint Cap Screw	Knuckle	35	48
Shock Absorber	Frame	50	68
Shock Absorber	Upper A-Arm	50	68

- * w/Red Loctite #271
- ** w/Green Loctite #609
- *** w/Blue Loctite #243
- **** "Patch-Lock"

ENGINE/TRANSMISSION			
Part	Part Bolted To	Torque ft-lb N-m	
Transmission Mounting Plate	Crankcase/Transmission	35	48
Connecting Rod Cap	Connecting Rod (4 Steps)	29	40
Main Bearing Cap	Engine Block (6 Steps)	44	60
Rocker Arm Support	Cylinder Head	29	40
Cylinder Head	Cylinder (5 Steps)	35	48
Valve Cover	Cylinder Head	6.5	9
Driven Pulley Nut**	Fixed Face	125	170
Drive Clutch	Flywheel/PTO Shaft	40	54
Movable Drive Face*	Fixed Drive Hub	85	116
Oil Pump	Engine Block	22	30
Output Shaft*	Output Shaft Coupler	20	27
Output Shaft Nut*	Output Shaft	80	108
Starter	V-Belt Housing	35	48
Flywheel/PTO Shaft	Crankshaft	40	54
Crankshaft Pulley	Timing Belt Drive Pulley	9	12
Chamber Ring Nut	Chamber (Step 1) (Step 2)	72 130	98 177
Glow Plug	Cylinder Head	18	24
Crankshaft Pulley***	Crankshaft	260	354
Timing Belt Idler Nut	Engine Block	29	39
V-Belt Cover	V-Belt Housing	9	12
V-Belt Housing	Crankcase/Transmission	25	34
Fuel Rail	Unit Injectors	36 in.-lb	4
Gear Case (Left)	Gear Case (Right)	8	11
Oil Pan	Crankcase	7	10
Oil Pan Cover	Oil Pan	7	10
Crankshaft Seal/Flange	Engine Block	9	12
Camshaft Support Housing	Cylinder Head	7	10
Fuel Injector Control Rack	Unit Injector	11 in.-lb	1.2
Unit Injector Retainer Nut	Cylinder Head (5 Steps)	15	20
Camshaft Drive Pulley	Camshaft	59	80
Lift Pump Eccentric	Camshaft	59	80
Water Pump	Engine Block	22	30

- * w/Red Loctite #271
- ** w/Green Loctite #609
- *** w/Blue Loctite #243

Torque Conversions (ft-lb/N-m)

ft-lb	N-m	ft-lb	N-m	ft-lb	N-m	ft-lb	N-m
1	1.4	26	35.4	51	69.4	76	103.4
2	2.7	27	36.7	52	70.7	77	104.7
3	4.1	28	38.1	53	72.1	78	106.1
4	5.4	29	39.4	54	73.4	79	107.4
5	6.8	30	40.8	55	74.8	80	108.8
6	8.2	31	42.2	56	76.2	81	110.2
7	9.5	32	43.5	57	77.5	82	111.5
8	10.9	33	44.9	58	78.9	83	112.9
9	12.2	34	46.2	59	80.2	84	114.2
10	13.6	35	47.6	60	81.6	85	115.6
11	15	36	49	61	83	86	117
12	16.3	37	50.3	62	84.3	87	118.3
13	17.7	38	51.7	63	85.7	88	119.7
14	19	39	53	64	87	89	121
15	20.4	40	54.4	65	88.4	90	122.4
16	21.8	41	55.8	66	89.8	91	123.8
17	23.1	42	57.1	67	91.1	92	125.1
18	24.5	43	58.5	68	92.5	93	126.5
19	25.8	44	59.8	69	93.8	94	127.8
20	27.2	45	61.2	70	95.2	95	129.2
21	28.6	46	62.6	71	96.6	96	130.6
22	29.9	47	63.9	72	97.9	97	131.9
23	31.3	48	65.3	73	99.3	98	133.3
24	32.6	49	66.6	74	100.6	99	134.6
25	34	50	68	75	102	100	136

Break-In Procedure

A new ATV and an overhauled ATV engine require a “break-in” period. The first 10 hours (or 200 miles) are most critical to the life of this ATV. Proper operation during this break-in period will help assure maximum life and performance from the ATV.

During the first 10 hours (or 200 miles) of operation, always use less than 1/2 throttle. Varying the engine RPM during the break-in period allows the components to “load” (aiding the mating process) and then “unload” (allowing components to cool). Although it is essential to place some stress on the engine components during break-in, care should be taken not to overload the engine too often. Do not pull a trailer or carry heavy loads during the 10-hour break-in period.

When the engine starts, allow it to warm up properly. Idle the engine several minutes until the engine has reached normal operating temperature.

During the break-in period, a maximum of 1/2 throttle is recommended; however, brief full-throttle accelerations and variations in driving speeds contribute to good engine break-in.

After the completion of the break-in period, the engine oil and oil filter should be changed. Other maintenance after break-in should include checking of all prescribed adjustments and tightening of all fasteners.

Fuel - Oil - Lubricant

■NOTE: Arctic Cat recommends the use of genuine Arctic Cat lubricants.

RECOMMENDED FUEL

The recommended fuel to use is biodiesel blend up to 20% (B20), #1 or #2 diesel fuel (42-50 cetane), or JP 5 or JP 8 turbine fuel. At temperatures above -10° C (14° F), use #2 diesel fuel or a biodiesel blend up to 20%. At temperatures at or below -10° C (14° F), use #1 diesel fuel. Diesel fuel with a minimum cetane number below 42 should not be used.

CAUTION

Never use biodiesel blends at temperatures at or below -10° C (14° F).

RECOMMENDED ENGINE OIL

The recommended oil to use is an oil which is rated SJ/CF under API service classification. These oils meet all of the lubrication requirements of the Arctic Cat engine. The recommended engine oil viscosity is SAE 10W-40. Ambient temperature should determine the correct weight of oil. See the viscosity chart or an authorized Arctic Cat ATV dealer for details.

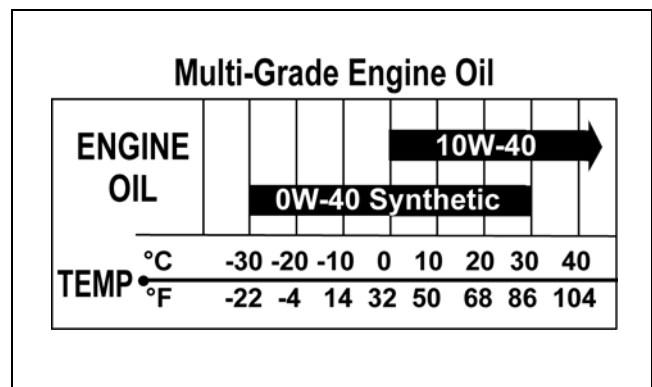

OILCHART

CAUTION

Any oil used in place of the recommended oil could cause serious engine damage.

RECOMMENDED TRANSMISSION LUBRICANT

The recommended transmission lubricant is SAE approved 80W-90 hypoid. This lubricant meets all of the lubrication requirements of the ATV transmission.

CAUTION

Any lubricant used in place of the recommended lubricant could cause serious transmission damage.

RECOMMENDED FRONT DIFFERENTIAL/REAR DRIVE LUBRICANT

The recommended lubricant is Arctic Cat Gear Lube or an equivalent gear lube which is SAE approved 80W-90 hypoid. This lubricant meets all of the lubrication requirements of the Arctic Cat ATV front differentials and rear drives.

CAUTION

Any lubricant used in place of the recommended lubricant could cause serious front differential/rear drive damage.

FILLING FUEL TANK

⚠ WARNING

Always fill the fuel tank in a well-ventilated area. Never add fuel to the ATV fuel tank near any open flames or with the engine running. DO NOT SMOKE while filling the fuel tank.

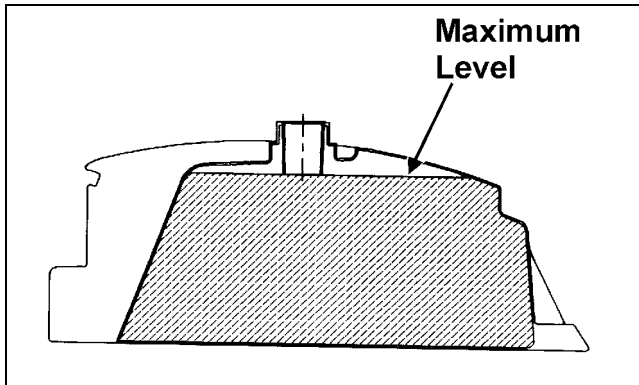

ATV0049B

Since fuel expands as its temperature rises, the fuel tank must be filled to its rated capacity only. Expansion room must be maintained in the tank particularly if the tank is filled with cold fuel and then moved to a warm area.

⚠ WARNING

Do not overflow fuel when filling the fuel tank. A fire hazard could materialize. Always allow the engine to cool before filling the fuel tank.

Tighten the fuel tank cap securely after filling the tank.

⚠ WARNING

Do not over-fill the fuel tank.

Genuine Parts

When replacement of parts is necessary, use only genuine Arctic Cat ATV parts. They are precision-made to ensure high quality and correct fit. Refer to the appropriate Illustrated Parts Manual for the correct part number, quantity, and description.

Preparation For Storage

CAUTION

Prior to storing the ATV, it must be properly serviced to prevent rusting and component deterioration.

Arctic Cat recommends the following procedure to prepare the ATV for storage.

1. Clean the seat cushion (cover and base) with a damp cloth and allow it to dry.
2. Clean the ATV thoroughly by washing dirt, oil, grass, and other foreign matter from the entire ATV. Allow the ATV to dry thoroughly. DO NOT get water into any part of the engine or air intake.
3. Fill the fuel tank with fresh #1 or #2 diesel fuel (according to ambient temperatures); then add a quality anti-microbial additive. Run the engine in a well-ventilated area for several minutes to make sure fresh, treated fuel is circulated throughout the entire injection system.

CAUTION

DO NOT store the ATV with biodiesel (B20) in the fuel system. Severe damage to the fuel system may occur.

4. Plug the exhaust hole in the muffler with a clean cloth.
5. Apply light oil to the upper steering post bushing and plungers of the shock absorbers.
6. Tighten all nuts, bolts, cap screws, and screws. Make sure rivets holding components together are tight. Replace all loose rivets. Care must be taken that all calibrated nuts, cap screws, and bolts are tightened to specifications.
7. Fill the cooling system to the bottom of the stand pipe in the filler neck with properly mixed coolant.
8. Disconnect the battery cables; then remove the battery, clean the battery posts and cables, and store in a clean, dry area.
9. Store the ATV indoors in a level position.

CAUTION

Avoid storing outside in direct sunlight and avoid using a plastic cover as moisture will collect on the ATV causing rusting.

Preparation After Storage

Taking the ATV out of storage and correctly preparing it will assure many miles and hours of trouble-free riding. Arctic Cat recommends the following procedure to prepare the ATV.

1. Clean the ATV thoroughly.
2. Clean the engine. Remove the cloth from the muffler.

3. Check all control wires and cables for signs of wear or fraying. Replace if necessary.
4. Change the engine oil and filter.
5. Check the coolant level and add properly mixed coolant as necessary.
6. Charge the battery; then install. Connect the battery cables.

CAUTION

The ignition switch must be in the OFF position prior to installing the battery or damage may occur to the electrical system.

CAUTION

Connect the positive battery cable first; then the negative.

7. Check the entire brake systems (fluid level, pads, etc.), all controls, headlights, taillight, brakelight, and headlight aim; adjust or replace as necessary.
8. Tighten all nuts, bolts, cap screws, and screws making sure all calibrated nuts, cap screws, and bolts are tightened to specifications.
9. Check tire pressure. Inflate to recommended pressure as necessary.
10. Make sure the steering moves freely and does not bind.

Periodic Maintenance/ Tune-Up

Tighten all nuts, cap screws, screws, and bolts. Make sure rivets holding components together are tight. Replace all loose rivets. Care must be taken that all calibrated nuts, cap screws, screws, and bolts are tightened to specifications.

It is advisable to lubricate certain components periodically to ensure free movement. Apply light oil to the components using the following list as reference.

- A. Throttle Lever Pivot/Cable Ends
- B. Brake Lever Pivot/Cable Ends
- C. Auxiliary Brake Cable Ends

Periodic Maintenance Chart

A = Adjust L = Lubricate
C = Clean R = Replace
I = Inspect

Item	Initial Service After Break-In (First Month or 100 Miles)	Every Month or Every 100 Miles	Every 3 Months or Every 300 Miles	Every 6 Months or Every 500 Miles	Every Year or Every 1250 Miles	Every 2 Years or Every 5000 Miles	As Needed
Battery	I	I					C
Fuses/Relays/PDM	I		I				R
Air Filter	I				R		R
Valve Clearance						I	A
Muffler/Spark Arrester				C			R
Fuel/Vent Hoses	I					R	
Fuel Injectors						I	A
Throttle Cable	I			C-L			A-R
Engine Oil Level							I
Engine Oil/Filter	Replace after initial 300 miles.				R		R
Front Differential/Rear Drive Lubricant	I						R (4 Yrs)
Transmission Lubricant	I		I				R (4 Yrs)
Tires/Air Pressure	I						R
Steering Components	I		I				R
V-Belt	I			I			R
Suspension (Ball joint boots, drive axle boots front and rear, tie rods, differential and rear drive bellows)	I		I*				R
Nuts/Cap Screws/Screws/Bolts	I			I			A
Injector Timing					I		A
Headlight/Taillight-Brakelight	I						R
Switches	I						R
Shift Lever				I			A-L
Handlebar Grips							R
Handlebars	I						R
Gauges/Indicators	I						R
Frame/Welds/Racks	I	I		I			
Electrical Connections				I			C
Complete Brake System (Hydraulic & Auxiliary)	I		C				L-R
Brake Pads	I						R
Brake Fluid	I					R	
Brake Hoses	I		I				R (4 Yrs)
Coolant/Cooling System	I	Replace coolant every 2 years.					
Timing Belt						R	
Alternator Belt	I				I		

* Service/Inspect more frequently when operating in adverse conditions.

Air Filter

CLEANING AND INSPECTING FILTER

CAUTION

Failure to inspect the air filter frequently if the vehicle is used in dusty, wet, or muddy conditions can damage the engine.

■NOTE: This ATV is equipped with a dry-paper air filter and a cotton-fabric safety element.

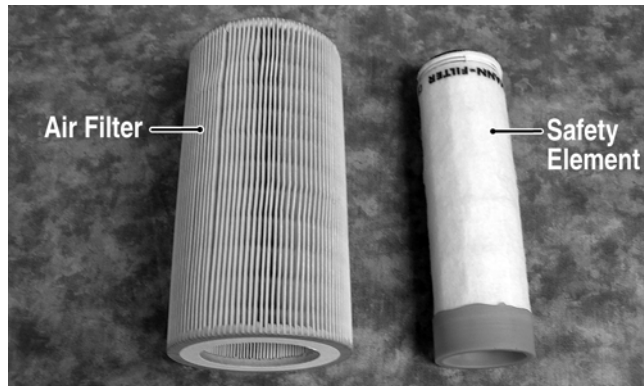

DE014A

1. Open the air filter access cover and remove the operator's seat; then rotate the air filter housing cover counterclockwise and remove from the filter housing.

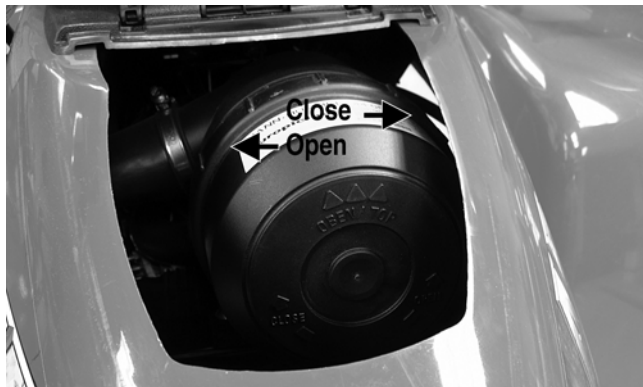

DE006A

2. Remove the dry-paper air filter. Do not remove the cotton-fabric safety element at this time.

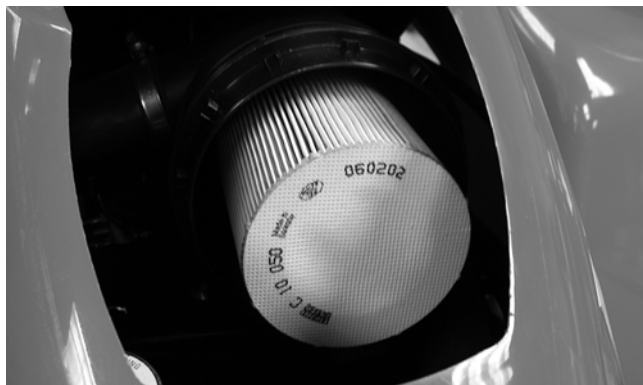

DE007

3. Clean dust and debris from the air filter housing; then remove the cotton-fabric safety element using care not to allow dirt and debris to enter the engine.



DE008

4. Lightly tap the dry-paper air filter to dislodge the dirt and dust. Do not use compressed air.
5. Insert a suitable light into the dry-paper air filter and look for any "pin-points" of light shining out of the filter medium. A bright "pin-point" of light indicates a hole and the filter element must be replaced.

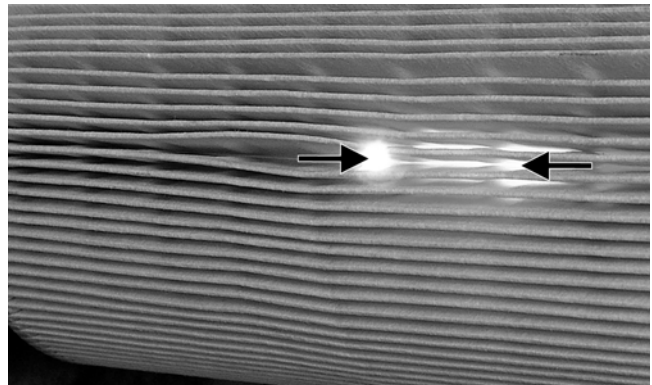

DE028A

CAUTION

A torn air filter can cause damage to the engine. Dirt and dust may enter the engine if the element is torn. Carefully examine the element for tears before and after cleaning it. Replace the element with a new one if it is torn.

6. Check the safety element for signs of dirt build-up. If dirt is present on the element, it indicates a leak or hole in the dry-paper air filter element and both elements must be replaced.
7. Install the safety element; then install the dry-paper air filter.
8. Check the drain valve in the air filter housing cover for dirt, deterioration, or poor sealing. Clean or replace as required.



DE015

9. Install the air filter housing cover (drain facing downward) and lock it in place by turning clockwise.



DE006A

Valve Clearance

To check/adjust valve clearance, see Top-Side Components in Engine/Transmission.

Muffler/Spark Arrester

The muffler has a spark arrester which must be periodically cleaned. At the intervals shown in the Periodic Maintenance Chart, clean the spark arrester using the following procedure.

⚠ WARNING

Wait until the muffler cools to avoid burns.

1. Remove the three cap screws securing the spark arrester assembly to the muffler; then loosen and remove the arrester.

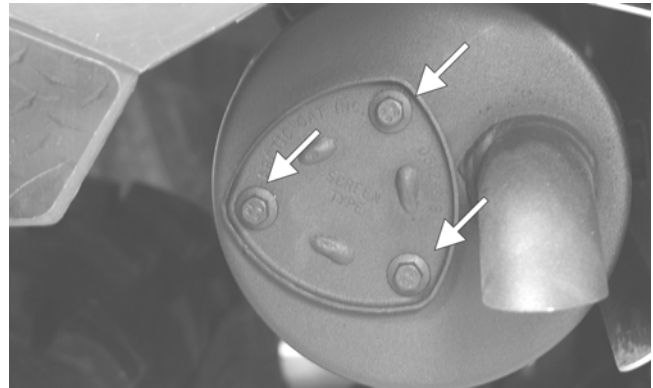

CF105A

2. Using a suitable brush, clean the carbon deposits from the screen taking care not to damage the screen.

■NOTE: If the screen or gasket is damaged in any way, it must be replaced.

3. Install the spark arrester assembly with gasket; then secure with three cap screws. Tighten to 48 in.-lb.

Adjusting Throttle Cable

To adjust the throttle cable free-play, follow this procedure.

1. Slide the rubber boot away; then loosen the jam nut from the throttle cable adjuster.

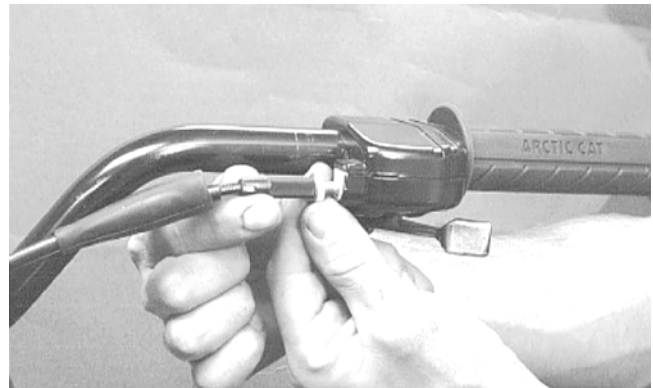

AL611D

2. Turn the adjuster until the throttle cable has proper free-play of 1/4 in. at the lever.

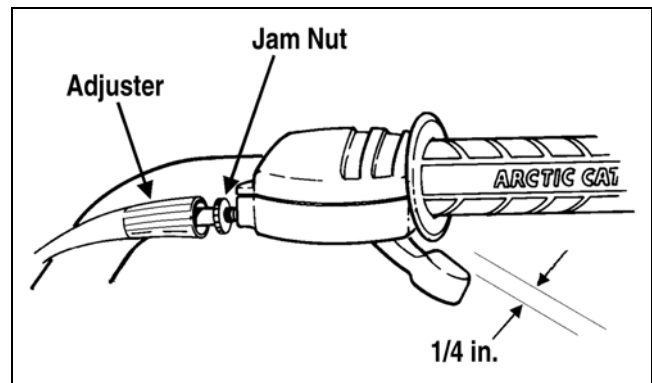

ATV-0047C

3. Tighten the jam nut against the throttle cable adjuster securely; then slide the rubber boot over the adjuster.

Engine RPM (Idle)

■NOTE: The idle RPM is not adjustable on the 700 Diesel.

Engine Oil - Filter

Change the engine oil and oil filter at the scheduled intervals. The engine should always be warm when the oil is changed so the oil will drain easily and completely.

1. Park the ATV on level ground.
2. Remove the engine oil filler cap.



DE025A

3. Remove the drain plug from the bottom of the engine and drain the oil into a drain pan.



DE017A

4. Remove the right-side engine cover.
5. Using a suitable filter wrench, remove the oil filter.

■NOTE: Clean up any excess oil after removing the filter.

6. Apply oil to a new filter O-ring and check to make sure it is positioned correctly; then install the new oil filter. Tighten until contact is made; then tighten an additional 3/4 turn.



DE018

■NOTE: Install a new O-ring each time the filter is replaced.

7. Install the engine drain plug and tighten to 18 ft-lb. Pour the specified amount of the recommended oil in the filler hole. Install the oil filler cap.

CAUTION

Any oil used in place of the recommended oil could cause serious engine damage. Do not use racing, vegetable, non-detergent, and castor-based oils.

8. Start the engine (while the ATV is outside on level ground) and allow it to idle for a few minutes.
9. Turn the engine off and wait approximately three minutes.
10. Remove the oil level stick and wipe it with a clean cloth.

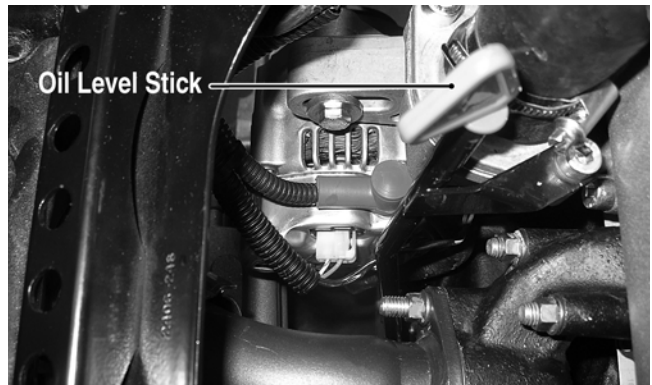

DE519D

11. Install the oil level stick and push in firmly.
12. Remove the oil level stick; the engine oil level should be above the illustrated "L" mark but not higher than the illustrated "F" mark.

CAUTION

Do not over-fill the engine with oil. Always make sure that the oil level is above the "L" mark but not higher than the "F" mark.

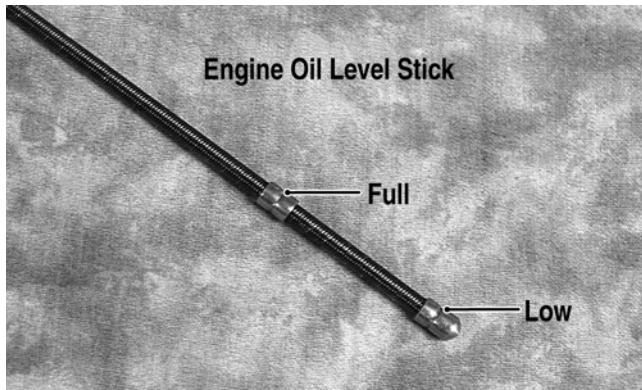

DE024A

13. Inspect the area around the drain plug and oil filter for leaks.
14. Install the right-side engine cover.

Transmission Lubricant

Check and change the transmission lubricant according to the Maintenance Schedule. When adding or changing the lubricant, use approved SAE 80W-90 hypoid and use the following procedure.

1. Place the ATV on level ground.
2. Remove the transmission fill plug. Make sure not to allow contaminants to enter the opening.

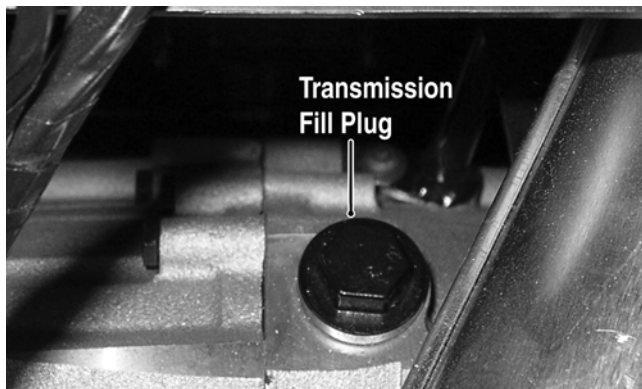

DE026A

3. Remove the transmission drain plug from the bottom of the transmission and drain the lubricant into a drain pan.



DE016A

4. Install the drain plug and tighten securely. Pour recommended lubricant into the filler hole. Install the filler plug.
5. Remove the transmission lubricant level stick and wipe it with a clean cloth; then check the lubricant level with the level stick.

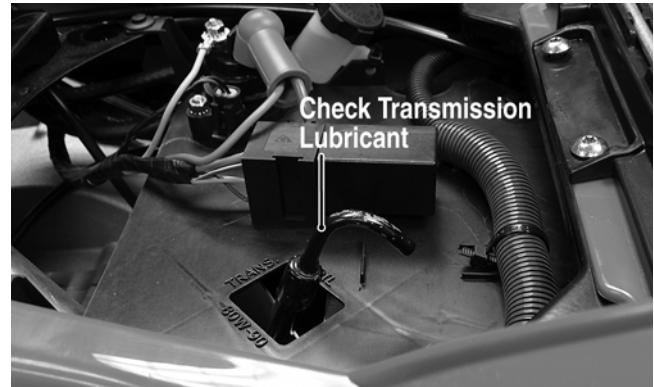

DE002A

Front Differential/Rear Drive Lubricant

Check and change the lubricant according to the Periodic Maintenance Chart. When adding or changing the lubricant, use approved SAE 80W-90 hypoid gear lube.

To check lubricant, remove the level plug; the lubricant level should be visible at the threads. If low, add SAE approved 80W-90 hypoid gear lube as necessary.

To change the lubricant, use the following procedure.

1. Place the ATV on level ground.
2. Remove each filler plug.
3. Drain the lubricant into a drain pan by removing in turn the drain plug from each.

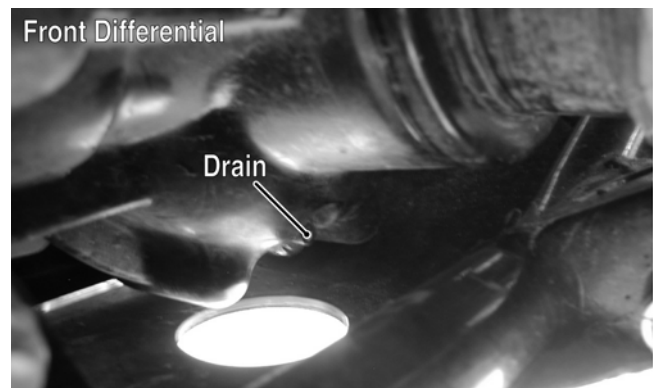

CF107B

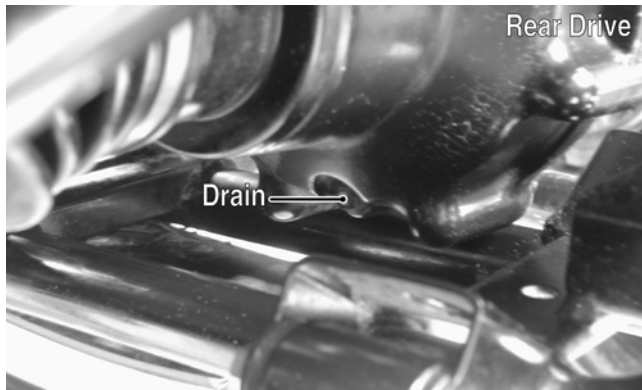

CF106C

4. After all the lubricant has been drained, install the drain plugs and tighten to 42 in.-lb.
5. Pour the appropriate amount of recommended lubricant into each filler hole.
6. Install the fill plugs. Tighten to 16 ft-lb.

NOTE: If the differential/rear drive lubricant is contaminated with water, inspect the drain plug and filler plug.

Tires

TIRE SIZES

The ATV is equipped with low-pressure tubeless tires of the size and type listed in General Specifications. Do not under any circumstances substitute tires of a different type or size.

WARNING

Always use the size and type of tires specified. Always maintain proper tire inflation pressure.

TIRE INFLATION PRESSURE

Front and rear tire inflation pressure should be 0.35 kg-cm² (5.0 psi).

Driveshaft/Coupling

The following drive system components should be inspected periodically to ensure proper operation.

- A. Spline lateral movement (slop).
- B. Coupling cracked, damaged, or worn.

Injector Timing

To check/adjust injector timing, see Top-Side Components in Engine/Transmission.

Lights

Each time the ATV is used, lights should be checked for proper function. Rotate the ignition switch to the lights position; the headlights and taillight should illuminate. Test the brakelight by compressing the brake lever. The brakelight should illuminate.

HEADLIGHT

NOTE: The bulb portion of the headlight is fragile. **HANDLE WITH CARE.** When replacing the headlight bulb, do not touch the glass portion of the bulb. If the glass is touched, it must be cleaned with a dry cloth before installing. Skin oil residue on the bulb will shorten the life of the bulb.

WARNING

Do not attempt to remove the bulb when it is hot. Severe burns may result.

To replace the headlight bulb, use the following procedure.

1. Remove the wiring harness connector from the back of the headlight.
2. Grasp the bulb housing, turn it counterclockwise, and remove the bulb.
3. Install the new bulb into the housing and rotate it completely clockwise.
4. Install the wiring harness connector.

TAILLIGHT-BRAKELIGHT

To replace the taillight-brakelight bulb, use the following procedure.

1. Turn the bulb socket counterclockwise and remove from the housing.

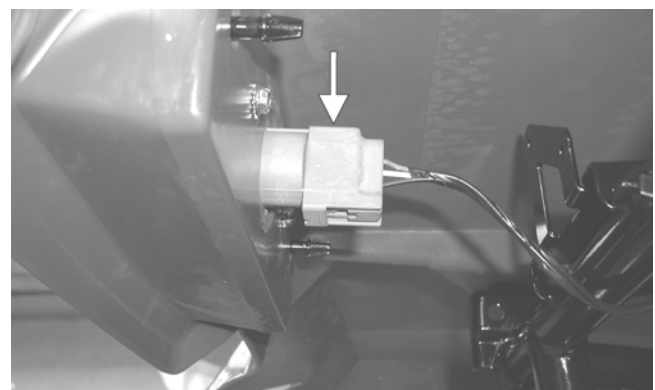

CF135A

2. Pull the bulb straight out of the socket; then insert a new bulb.

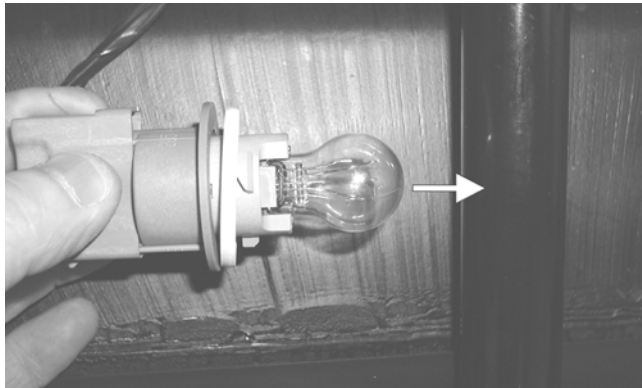

CF132A

3. Insert the socket into the housing and turn it clockwise to secure.

CHECKING/ADJUSTING HEADLIGHT AIM

The headlights can be adjusted vertically and horizontally. The geometric center of the HIGH beam light zone is to be used for vertical and horizontal aiming.

1. Position the ATV on a level floor so the headlights are approximately 6.1 m (20 ft) from an aiming surface (wall or similar aiming surface).

■NOTE: There should be an average operating load on the ATV when adjusting the headlight aim.

2. Measure the distance from the floor to the mid-point of each headlight.
3. Using the measurements obtained in step 2, make horizontal marks on the aiming surface.
4. Make vertical marks which intersect the horizontal marks on the aiming surface directly in front of the headlights.
5. Switch on the lights. Make sure the HIGH beam is on. DO NOT USE LOW BEAM.
6. Observe each headlight beam aim. Proper aim is when the most intense beam is centered on the vertical mark 5 cm (2 in.) below the horizontal mark on the aiming surface.

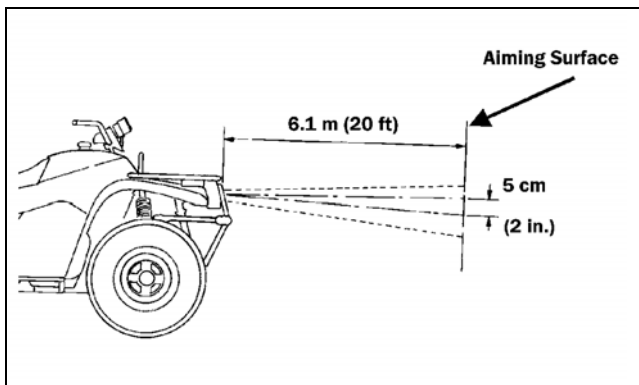

ATV-0070C

7. Adjust each headlight by turning the adjuster knob clockwise to raise the beam or counterclockwise to lower the beam.

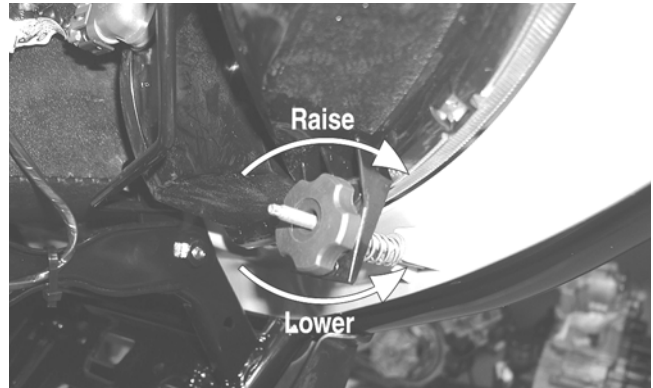

CD714A

Shift Lever

CHECKING ADJUSTMENT

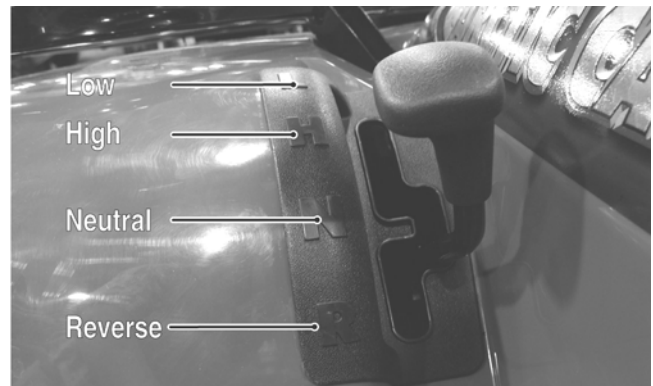

CF130B

Stop the ATV completely and shift the transmission into the R position. The reverse gear indicator light should be illuminated.

⚠ WARNING

Never shift the ATV into reverse gear when the ATV is moving as it could cause the ATV to stop suddenly throwing the operator from the ATV.

If the reverse light does not illuminate when shifted to the reverse position, the switch may be faulty, the fuse may be blown, the bulb may be faulty, a connection may be loose or corroded, or the lever may need adjusting. To adjust, proceed to Adjusting Shift Lever.

ADJUSTING SHIFT LEVER

1. Place the shift lever in the R position; then remove the seat and left-side engine cover.
2. With the ignition switch in the ON position, loosen jam nut (A) (left-hand threads); then loosen jam nut (C) and with the shift lever in the reverse position, adjust the coupler (B) until the transmission is in reverse and the (R) icon appears on the LCD.

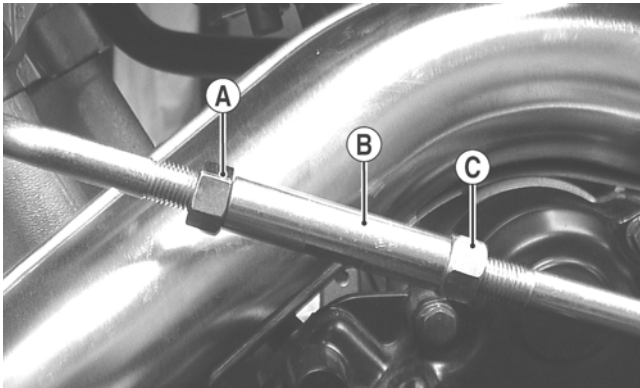

CF258A

3. Tighten the jam nuts securely; then shift the transmission to each position and verify correct adjustment.

■NOTE: An E (Error) in the gear position icon indicates no signal or a poor ground wire connection in the circuit. Troubleshoot the harness connectors, gear shift position connector, gear shift position switch, and LCD connector.

4. Install the seat and left-side engine cover.

Frame/Welds/Racks

The frame, welds, and racks should be checked periodically for damage, bends, cracks, deterioration, broken components, and missing components. If replacement or repair constitutes removal, see Steering/Frame.

Hydraulic Brake Systems

CHECKING/BLEEDING

The hydraulic brake systems have been filled and bled at the factory. To check and/or bleed a hydraulic brake system, use the following procedure.

1. With the master cylinder in a level position, check the fluid level in the reservoir. If the level in the reservoir is not visible in the sight glass, add DOT 4 brake fluid.

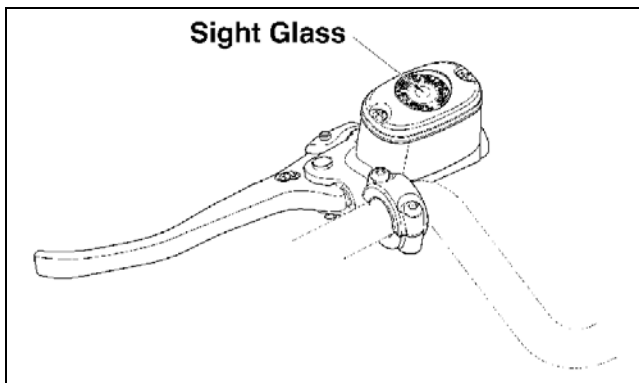

738-420A



AL681

2. Compress the brake lever/pedal several times to check for a firm brake. If the brake is not firm, the system must be bled. To bleed the main brake system, use the following procedure.

A. Remove the cover and fill the reservoir with DOT 4 Brake Fluid; then install and secure the cover.

B. Slowly compress the brake lever several times.

C. Remove the protective cap, install one end of a clear hose onto one FRONT bleeder screw, and direct the other end into a container; then while holding slight pressure on the brake lever, open the bleeder screw and watch for air bubbles. Close the bleeder screw before releasing the brake lever. Repeat this procedure until no air bubbles are present.



AF637D

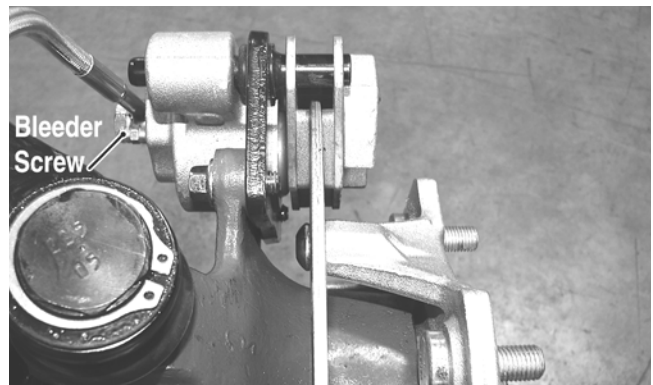

PR377C

■NOTE: During the bleeding procedure, watch the reservoir/sight glass very closely to make sure there is always a sufficient amount of brake fluid. If low, refill the reservoir before the bleeding procedure is continued. Failure to maintain a sufficient amount of fluid in the reservoir will result in air in the system.

D. At this point, perform step B and C on the other FRONT bleeder screw; then move to the REAR bleeder screw and follow the same procedure.

E. Repeat step D until the brake lever is firm.

3. Carefully check the entire hydraulic brake system that all hose connections are tight, the bleed screws are tight, the protective caps are installed, and no leakage is present.

CAUTION

This hydraulic brake system is designed to use DOT 4 brake fluid only. If brake fluid must be added, care must be taken as brake fluid is very corrosive to painted surfaces.

INSPECTING HOSES

Carefully inspect the hydraulic brake hoses for cracks or other damage. If found, the brake hoses must be replaced.

CHECKING/REPLACING PADS

The clearance between the brake pads and brake discs is adjusted automatically as the brake pads wear. The only maintenance that is required is replacement of the brake pads when they show excessive wear. Check the thickness of each of the brake pads as follows.

1. Remove a front wheel.
2. Measure the thickness of each brake pad.
3. If thickness of either brake pad is less than 1.0 mm (0.039 in.), the brake pads must be replaced.

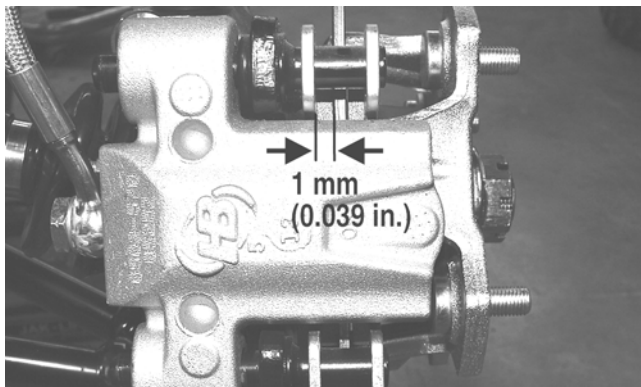

PR376B

■NOTE: The brake pads should be replaced as a set.

4. To replace the brake pads, use the following procedure.
 - A. Remove the wheel.
 - B. Remove the cap screws securing the caliper holder to the knuckle; then remove the pads.



PR237

C. Install the new brake pads.

D. Secure the caliper holder to the knuckle and/or axle housing with the cap screws. Tighten to 20 ft-lb.

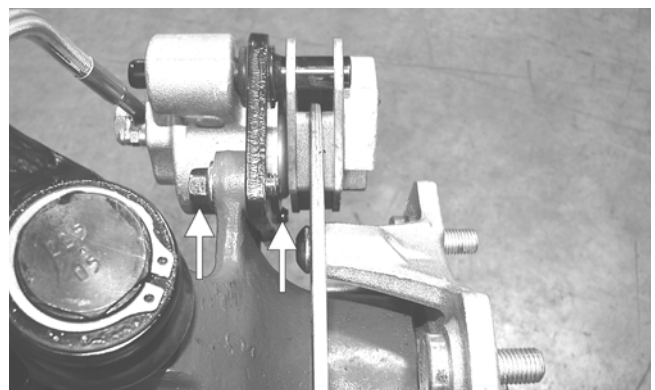

PR377B

E. Install the wheel. Tighten to 45 ft-lb (steel wheels) or 80 ft-lb (aluminum wheels).

5. Burnish the brake pads (see Burnishing Brake Pads).

Burnishing Brake Pads

Brake pads (both hydraulic and auxiliary) must be burnished to achieve full braking effectiveness. Braking distance will be extended until brake pads are properly burnished. To properly burnish the brake pads, use the following procedure.

WARNING

Failure to properly burnish the brake pads could lead to premature brake pad wear or brake loss. Brake loss can result in severe injury.

1. Choose an area large enough to safely accelerate the ATV to 30 mph and to brake to a stop.
2. Accelerate to 30 mph; then compress brake lever or apply the auxiliary brake to decelerate to 0-5 mph.
3. Repeat procedure on each brake system 20 times until brake pads are burnished.
4. Adjust the auxiliary brake (if necessary).
5. Verify that the brakelight illuminates when the hand lever is compressed or the brake pedal is depressed.

Coolant

When filling the cooling system, use a coolant/water mixture which will satisfy the coldest anticipated weather conditions of the area in accordance with the coolant manufacturer's recommendations. While the cooling system is being filled, air may become trapped; therefore, elevate the rear of the ATV 30-40 cm (12-16 in.) to allow air to bleed from the filler neck. Run the engine for several minutes; then shut off the engine and fill with coolant to the top of the filler neck.

■NOTE: Use a good quality, biodegradable glycol-based, automotive-type antifreeze.

⚠ WARNING

Never check the coolant level when the engine is hot or the cooling system is under pressure.

CAUTION

After operating the ATV for the initial 5-10 minutes, stop the engine, allow the engine to cool down, and check the coolant level. Add coolant as necessary.

To check/add coolant, use the following procedure.

1. Check the level of coolant in the coolant expansion tank located under the right front fender. The coolant level should be between the Full Cold and Full Hot lines.



DE019A

2. Remove the rubber plug from the neck of the coolant expansion tank and add coolant as necessary; then install the plug.
3. Remove the filler cap located under the service access cover and add coolant as necessary to bring coolant level to the top of the filler neck. Install and tighten the filler cap.

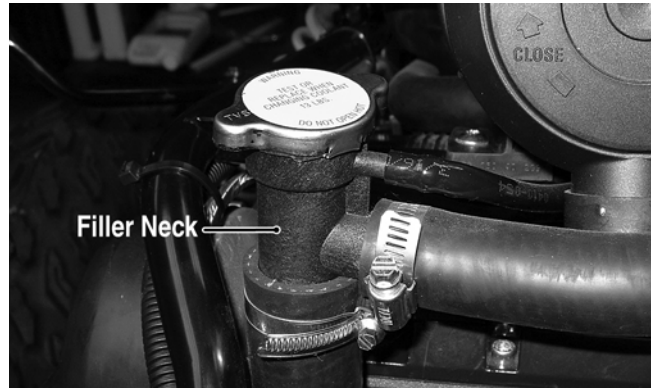

DE073A

Checking/Replacing V-Belt

REMOVING

1. Remove the right-side footrest (see Steering/Frame).
2. Remove the cap screws securing the V-belt cover; then using a rubber mallet, gently tap on the cover tabs to loosen the cover. Remove the cover.
3. Remove the cap screw securing the drive clutch to the flywheel stub axle; then remove the nut and lock washer securing the movable drive face to the fixed drive hub.

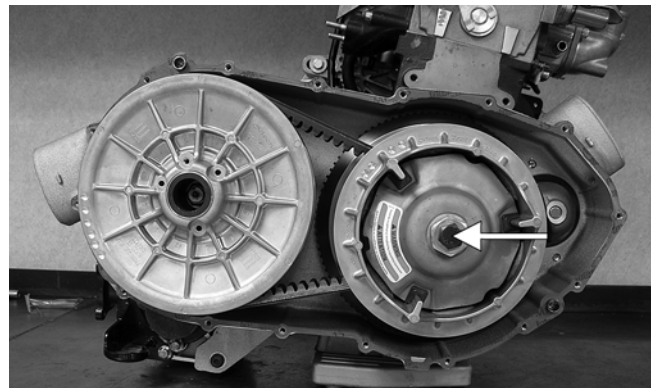

DE093A

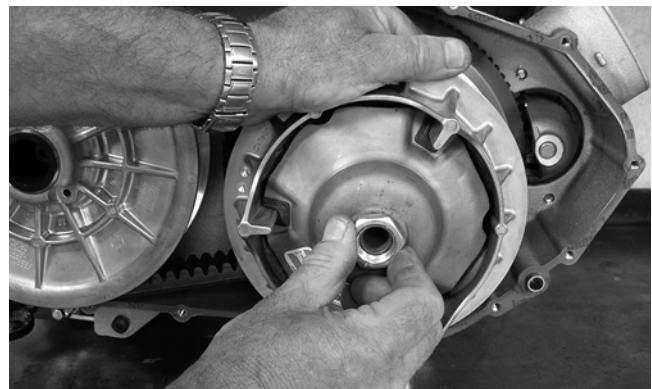

DE095

4. Remove the movable drive face using care to keep the face plate tight against the drive face to prevent the weights from falling out. Account for a spring seat, spring, bushing, and lock washer.

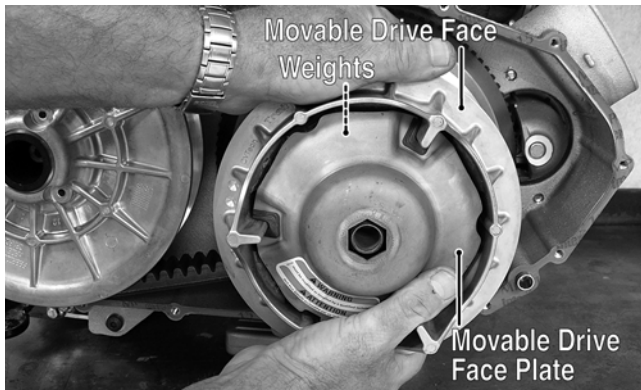

DE096A

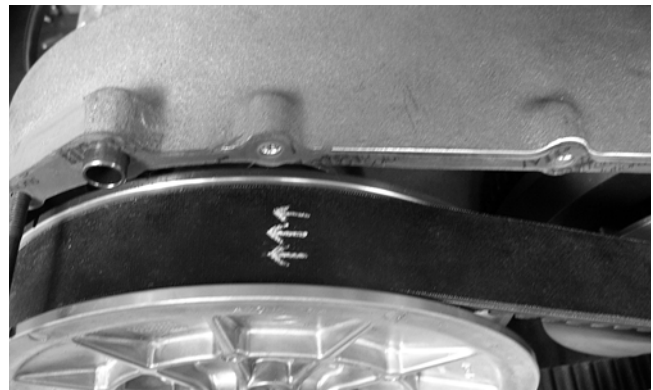

DE488

■ **NOTE:** The diesel engine in this ATV rotates counterclockwise as viewed from the right side; therefore, if directional arrows are printed on the V-belt, they must be directed rearward.

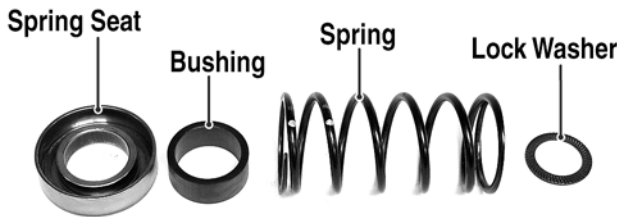

DE094A

5. Thread one of the V-belt cover screws into the fixed driven face and turn clockwise to open the driven pulley faces.
6. Push the V-belt down between the sheaves of the driven pulley approximately one inch; then making sure not to dislocate the one-way clutch from the fixed drive hub, squeeze the belt together and remove from the drive clutch.

2. Push the V-belt down into the driven pulley approximately one inch; then squeeze the belt together and slide over the fixed drive hub and onto the one-way clutch.

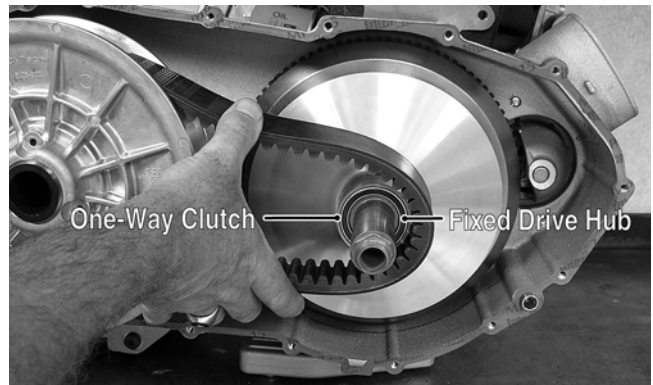

DE098A

3. Pinch the V-belt together near its center and slide the movable drive face onto the drive hub. Secure the drive face with a nut (threads coated with red Loctite #271). Tighten the nut to 85 ft-lb.



DE098A

INSTALLING

1. Place the V-belt into position over the driven pulley noting the directional arrows on the V-belt.



DE483

■ **NOTE:** At this point, the cap screw can be removed from the fixed driven face.

4. Rotate the V-belt and pulley until the V-belt is flush with the top of the driven pulley.
5. Install the cap screw securing the drive clutch assembly to the flywheel/PTO shaft and tighten to 40 ft-lb.

- Place the V-belt cover gasket into position; then install the cover and secure with the cap screws. Tighten to 9 ft-lb.

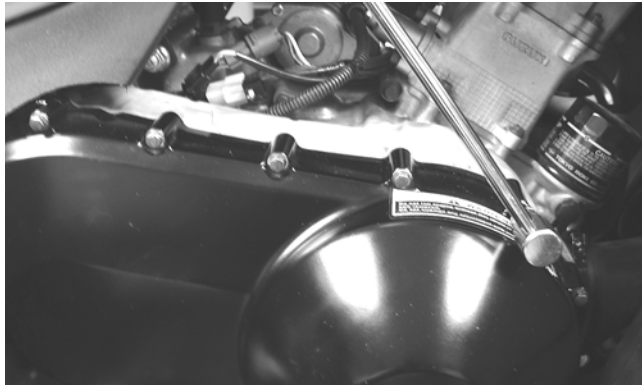

CD083

- Secure the front fender to the footrest with the two cap screws. Tighten securely.
- Install the right-side footrest (see Steering/Frame).

Fuel Filter

This diesel-powered ATV is equipped with a high efficiency fuel filter. The fuel filter should be changed in accordance with the maintenance schedule or more often if operated under severe conditions or winter operation. To change the fuel filter, use the following procedure.

- Remove the right front fender splash panel; then using an appropriate filter wrench, remove the fuel filter.
- Apply a light coat of oil to the seal ring of the new fuel filter; then install the filter. Tighten until the seal ring contacts the filter head; then tighten an additional 3/4 turn.



DE032D

- Depress and release the manual primer pump to charge the fuel filter and purge any air from the system.

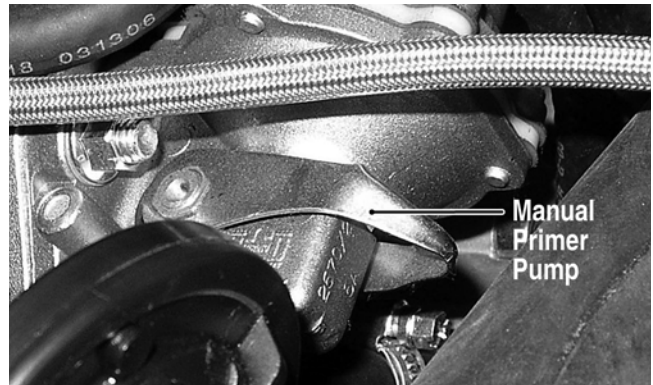

DE031A

■ **NOTE:** Cycle the manual primer pump until the lever becomes firm and resistance is observed. The system will bleed itself through the tank return circuit.

- Check for any fuel leaks; then start the engine and check for normal engine operation.

Engine/Transmission

This section has been organized into sub-sections which show a progression for the complete servicing of the Arctic Cat ATV engine/transmission.

To service the crankcase, the engine must be removed from the frame.

To service top-side, left-side, and right-side components (except cylinder head), the engine does not have to be removed from the frame.

■NOTE: Arctic Cat recommends the use of new gaskets, lock nuts, and seals and lubricating all internal components when servicing the engine/transmission.

SPECIAL TOOLS

A number of special tools must be available to the technician when servicing the engine/transmission.

Description	p/n
Torx-Head Screwdriver - #30	0644-344
Drive Clutch Removal Tool	0444-226
Engine Locking Tool	0444-245
Fuel Injector Timing Tool	0444-234
Timing Belt Tensioning Tool	0444-231
Main Bearing Seal Installation Tool	0444-233
Unit Injector Retainer Nut Tool	0444-227
Pre-Combustion Chamber Ring Nut Tool	0444-235
Pre-Combustion Chamber Removal Tool	0444-228
Pre-Combustion Chamber Index Tool	0444-229
Valve Seal Installation Tool	0444-230

■NOTE: Special tools are available from the Arctic Cat Service Parts Department.

Removing Engine/ Transmission

Many service procedures can be performed without removing the engine/transmission from the frame. Closely observe the note introducing each sub-section for this important information.

AT THIS POINT

If the technician's objective is to service/replace left-side components, right-side components, and/or top-side components, the engine/transmission does not have to be removed from the frame.

AT THIS POINT

If the technician's objective is to service/replace the transmission, the engine does not have to be removed from the frame (proceed to Transmission in this sub-section).

ENGINE/TRANSMISSION

1. Remove the seat; then from the rear, remove the battery cables (negative first) and the battery.
2. Remove the front rack, front body panel, and left and right footrests (see Steering/Frame).
3. Drain the coolant, engine oil, and transmission lubricant (see Periodic Maintenance/Tune-Up).
4. From the left side, remove the E-clip from the shift arm; then disconnect the shift linkage from the shift arm. Account for a bushing and washer.

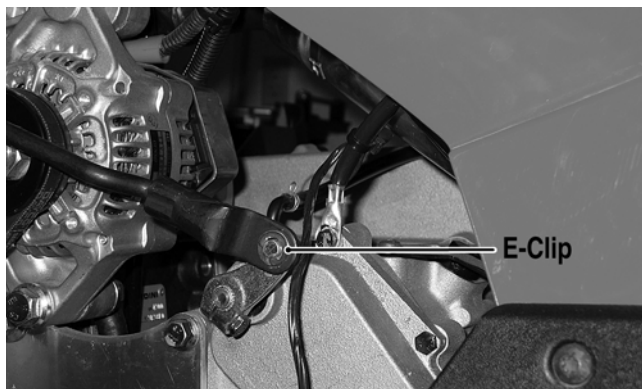

DE064A

5. Disconnect the speed sensor connector from the speed sensor; then remove the cap screw securing the engine and main harness ground to the transmission.

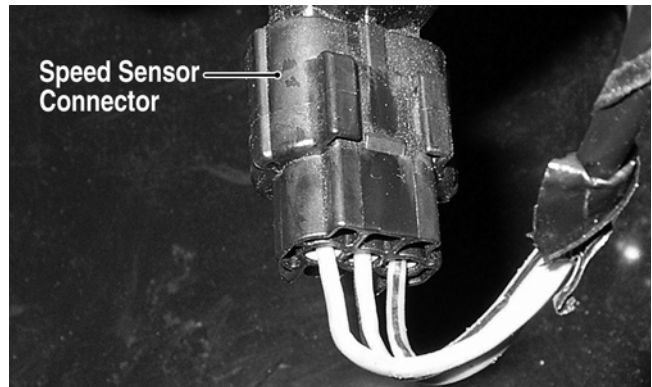

DE066A

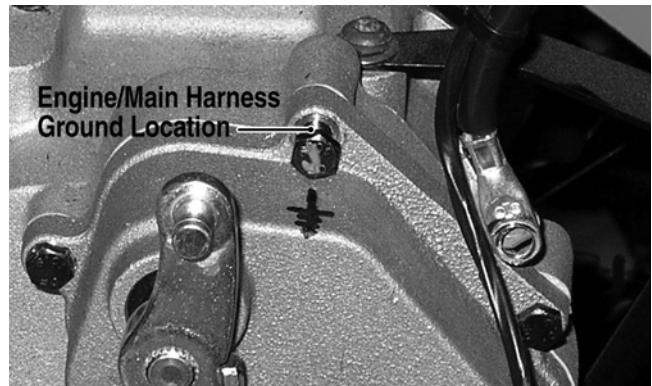

DE071A

6. Loosen the two hose clamps securing the air diverter to the inlet hoses; then remove the air diverter.
7. Remove the upper radiator hose from the filler neck; then loosen the hose clamp securing the filler neck to the thermostat housing and remove the filler neck.

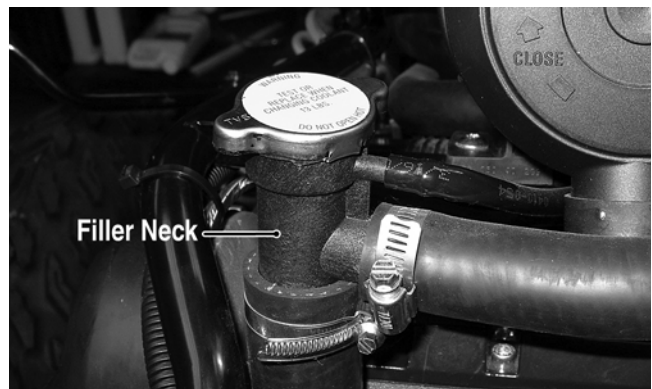

DE073A

■ **NOTE:** Filler neck can remain attached to the overflow recovery hose.

8. Remove the upper radiator hose from the radiator.
9. Remove the four cap screws securing the air filter housing assembly to the frame; then disconnect the air inlet hose from the intake manifold and remove the air filter housing assembly.



DE074A

10. Remove the V-belt cooling fan assembly; then disconnect the V-belt inlet and outlet cooling boots from the V-belt housing.

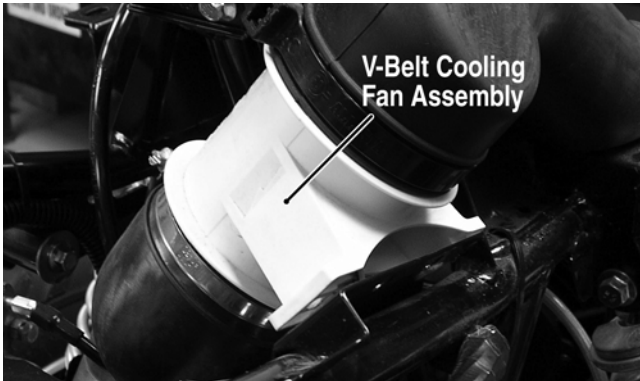

DE076A

11. Remove the fuel inlet and lift pump output hoses from the lift pump. Discard four crush washers.

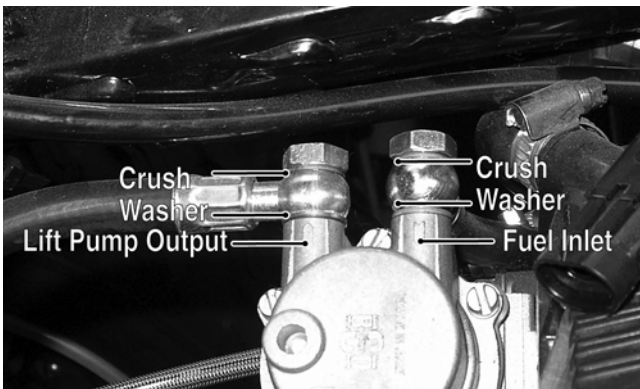

DE078A

12. Remove the fuel supply and fuel return hoses from the fuel rail.

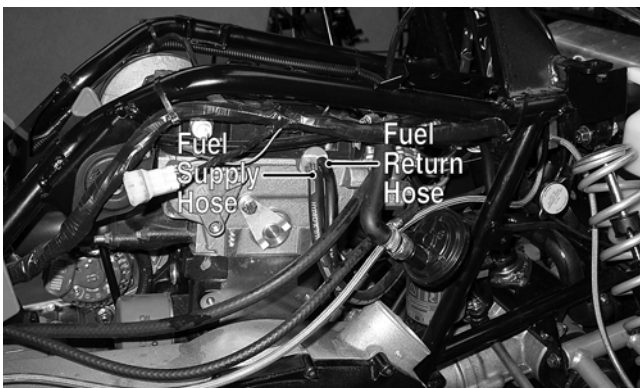

DE065A

CAUTION

The fuel rail connections are easily bent. Use care when removing the hose clamps and hoses.

13. Disconnect the wire connectors from the temperature sensor, oil pressure sensor, gear position switch connector, and voltage regulator; then disconnect the starter solenoid, glow plug power wire, and the alternator positive wire.

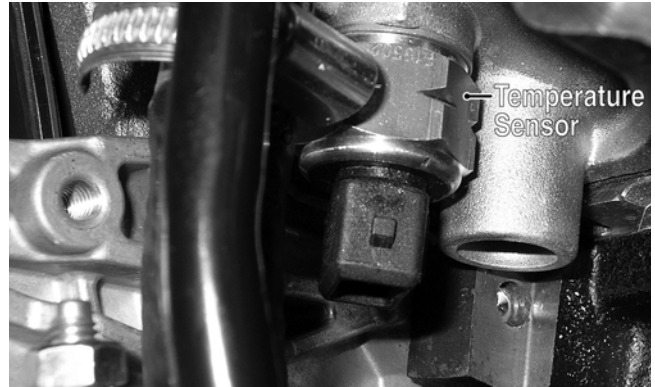

DE104A

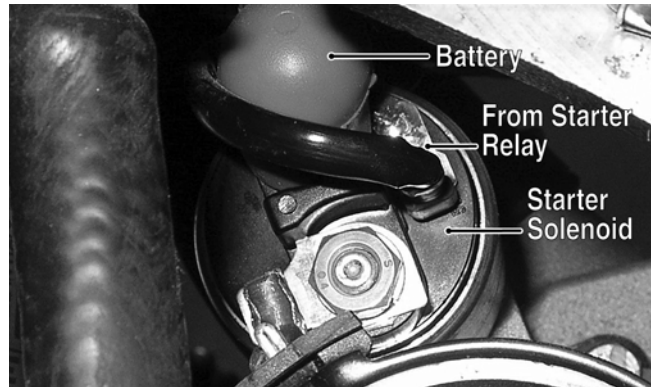

DE067A

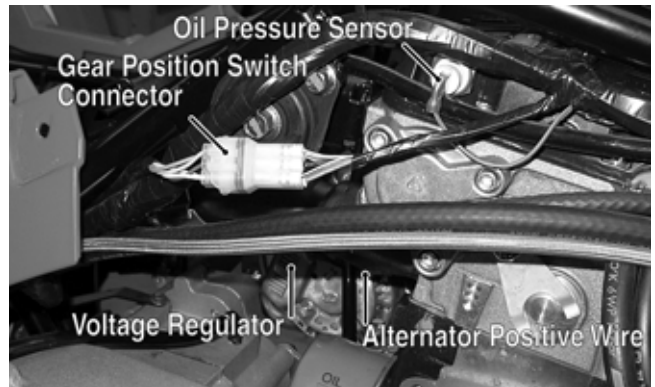

DE077C



DE494A

14. Apply the hand brake and engage the brake lever lock; then remove the cap screws from the front drive coupler.



DE086A

19. Remove the cap screw and nut from the upper right engine mount. Account for a flat washer.

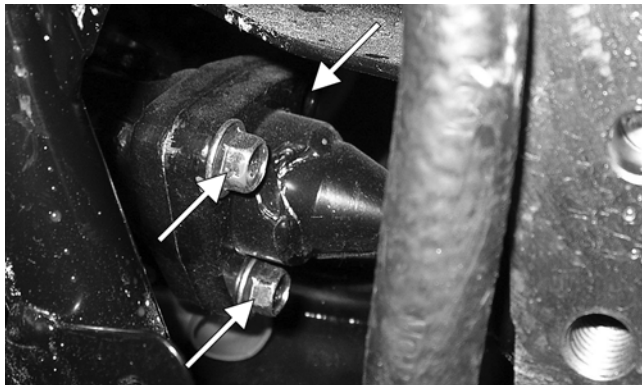

DE081A

15. Remove the cap screws from the rear drive coupler.

16. Remove the exhaust springs; then remove the muffler. Account for a grafoil seal.

17. Remove the nuts securing the exhaust pipe to the exhaust manifold; then remove the exhaust pipe. Account for a steel gasket.

18. Place a suitable block between the oil pan and frame member; then remove the front engine mount cap screw and nut. Account for a flat washer.

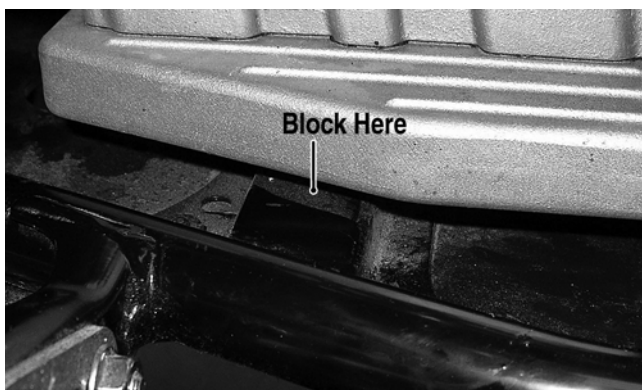

DE089A



DE088A

20. Remove the nuts and cap screws from the left rear and right rear engine mounts. Account for two flat washers.

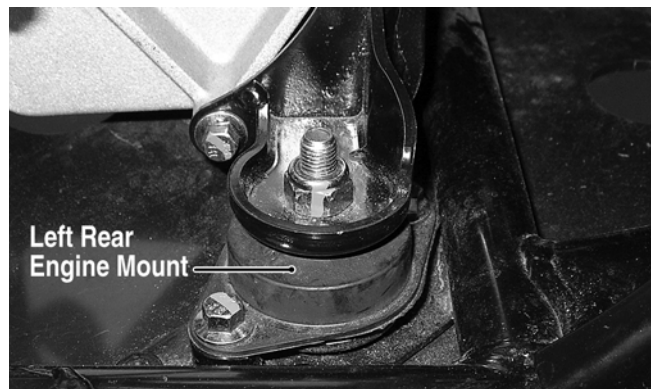

DE085A



DE090A

- Remove the transmission level stick mount and housing; then disconnect the throttle cable from the throttle control arm and unthread the throttle cable housing. Route the throttle cable away from the engine.

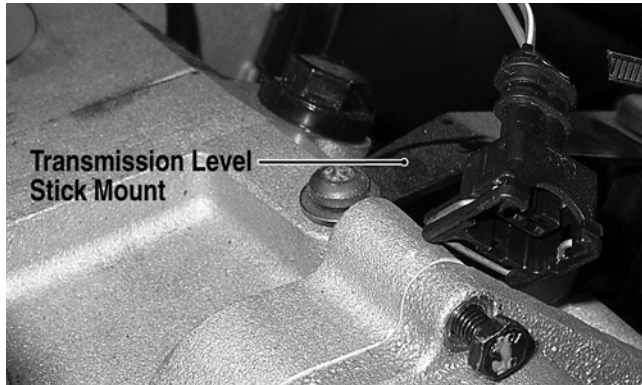

DE091A

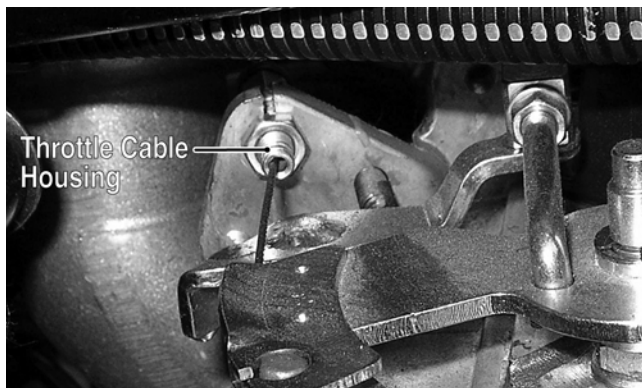

DE080A

- Move the engine/transmission slightly forward and shift the rear propeller shaft to the right; then rotate the rear of the assembly out of the left side.

■NOTE: The front engine mount bracket and fuel filter housing can be removed to allow more clearance at the front of the engine.

- Remove the front propeller shaft from the transmission output yoke; then slide the engine/transmission out the left side lifting the transmission to tilt the engine sufficiently forward for the top of the engine to clear the upper frame tubes.

- Attach a suitable lift and lift the engine free of the frame.

TRANSMISSION

■NOTE: The transmission can be removed for servicing without removing the engine. To remove the transmission, use the following procedure.

- Remove the inner front splash shields, foot pegs, and forward footwells (see Steering/Frame).
- Remove three cap screws securing the front propeller shaft to the front differential input coupler.
- Remove four cap screws securing the rear propeller shaft to the output drive flange.
- Remove the transmission level stick housing and account for an O-ring.

- Drain the transmission lubricant into a suitable container; then disconnect the transmission vent hose, gear shift position switch connector, speed sensor connector, and shift linkage.
- Remove the V-belt (see Periodic Maintenance/Tune-Up).
- Remove the nut securing the driven pulley to the transmission input shaft; then remove the driven pulley. Account for a flat washer, square key, and four shims.



DE106A



DE108

- Remove the nuts from the left rear and right rear engine mount bolts; then remove the bolts. Account for two flat washers.

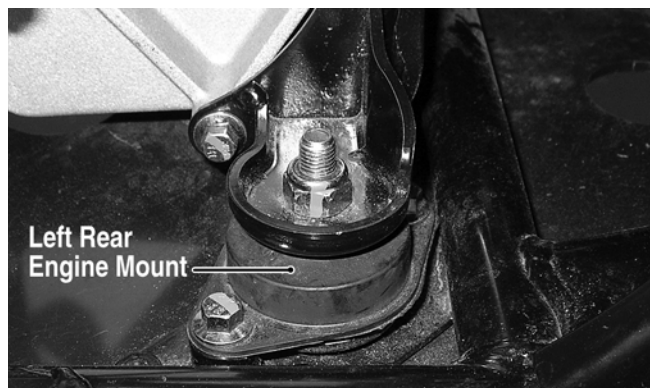

DE085A



DE090A

9. Block the rear of the engine up; then remove the rear mounts from the transmission.
10. Remove five cap screws securing the transmission to the V-belt housing; then remove four cap screws securing the engine-to-transmission mounting plate.

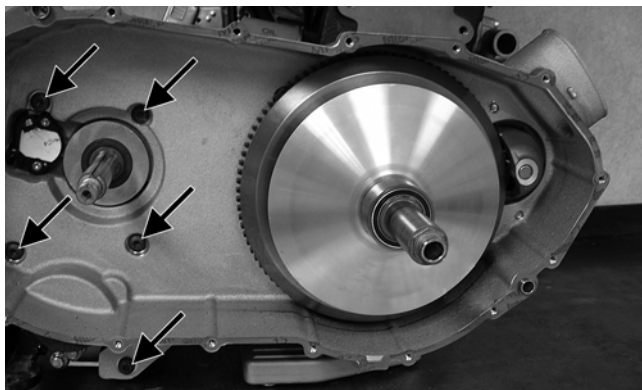

DE589A



DE487

11. Slide the transmission to the left side until the rear output flanges can be separated; then move the transmission to the rear to expose the front output yoke boot.
12. Slide the boot off the yoke and separate the front propeller shaft from the front output drive yoke.

Top-Side Components

■NOTE: For efficiency, it is preferable to remove and disassemble only those components which need to be addressed and to service only those components. The technician should use discretion and sound judgment.

AT THIS POINT

To service any one specific component, only limited disassembly of components may be necessary. Note the AT THIS POINT information in each sub-section.

■NOTE: The engine/transmission does not have to be removed from the frame for this procedure.

SPEED GOVERNOR

Removing/Disassembling

1. Remove the timing belt (see Left-Side Components in this section).
2. Remove the air filter assembly; then remove the valve cover.



DE074

3. Disconnect the throttle cable; then remove the cap screws securing the intake manifold/throttle cable housing to the cylinder head.

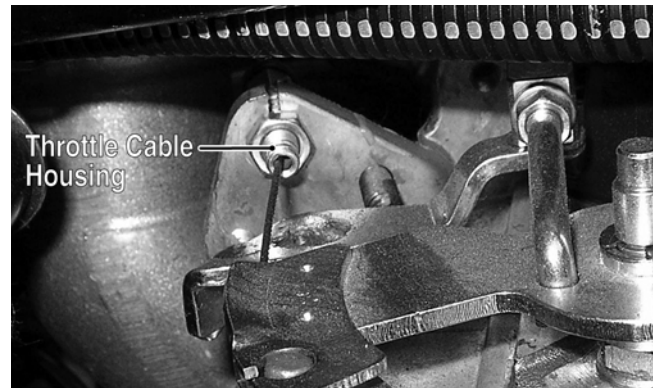

DE080A

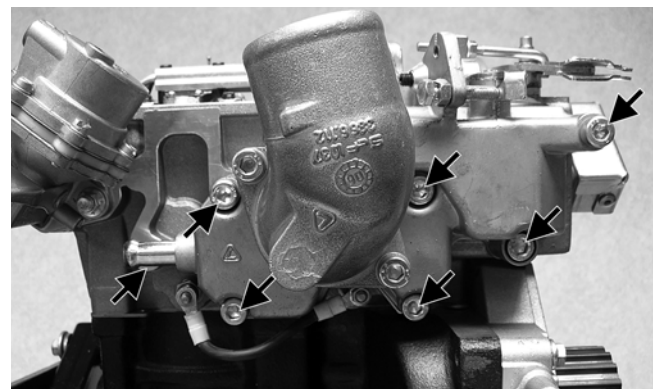

DE248A

- Disconnect the high-low speed spring assembly from the throttle control arm; then remove the intake manifold/throttle control housing. Account for a gasket.

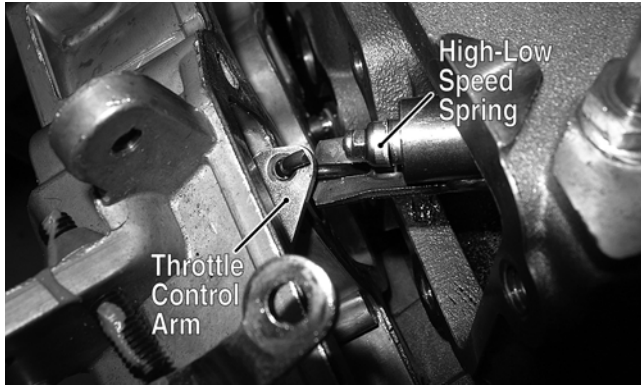

DE258A

- Rotate the crankshaft in the direction of rotation approximately 90° from TDC.

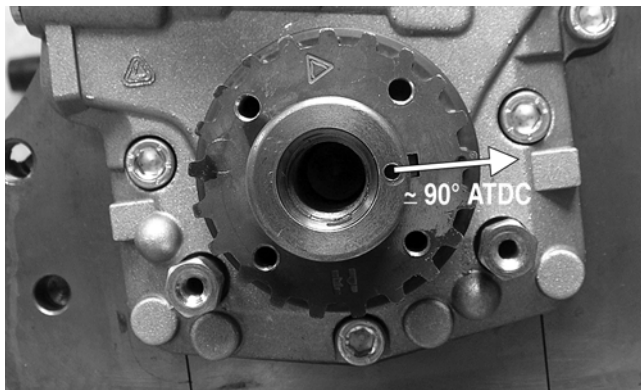

DE275A

CAUTION

Failure to rotate the engine away from TDC will leave the flywheel-side piston in close proximity to the valves. If the camshaft is rotated while attempting to remove the camshaft drive pulley, severe valve damage WILL occur.

- Using a suitable holding tool, remove the cap screw securing the camshaft drive pulley; then remove the pulley.

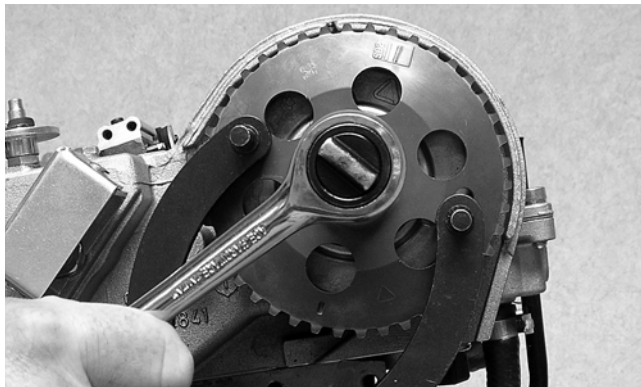

DE276

- Remove the front camshaft support housing; then remove the governor flyweight assembly. Account for a small O-ring.

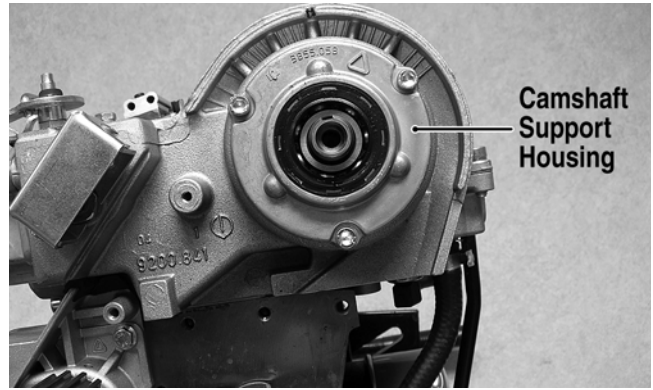

DE245A

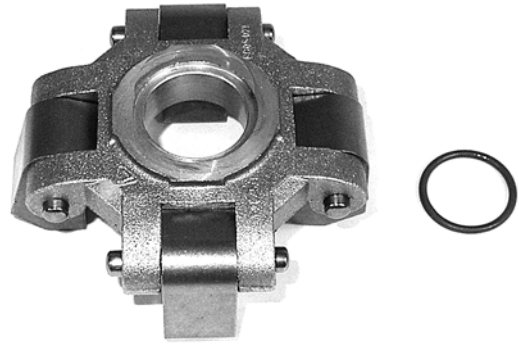

DE277

- Remove the control spool, thrust bearing, and thrust washer. Note the order of disassembly and keep together and in order for assembling purposes.

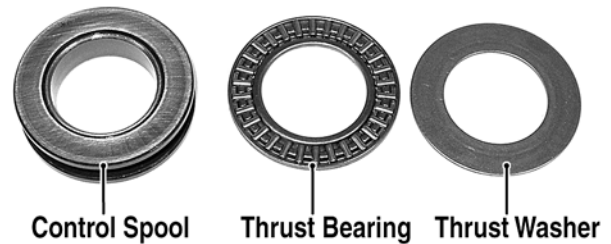

DE278A



DE279

- Remove the torque limiter safety cover; then remove the torque limiter assembly. Account for a copper washer.

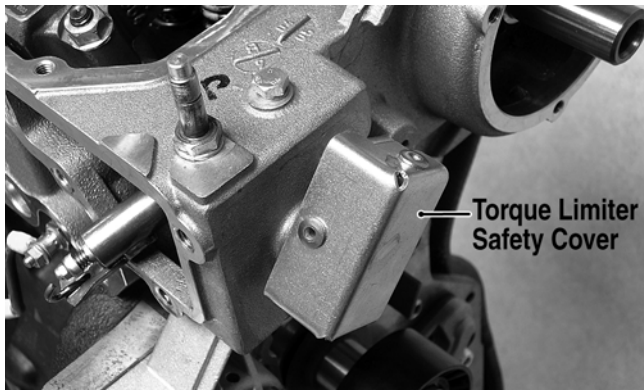

Torque Limiter Safety Cover

DE252A

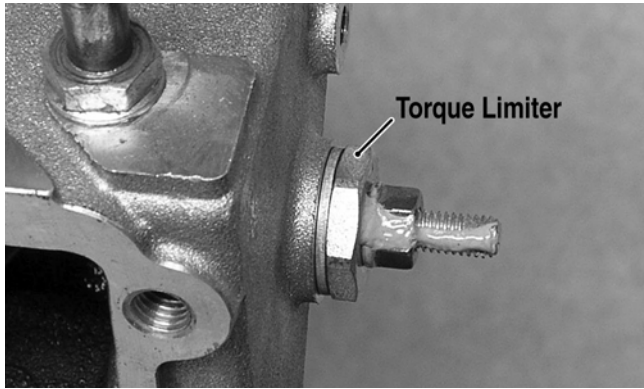

Torque Limiter

DE285A



Copper Washer

Torque Limiter Assembly

DE286A

CAUTION

Do not break the seal or turn the torque limiter adjuster screw. Severe engine damage could occur.

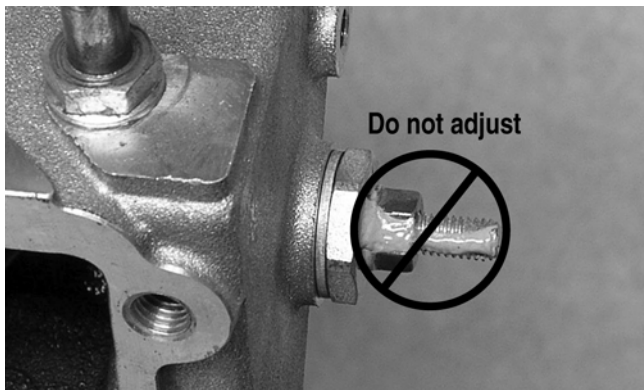

Do not adjust

DE285B

10. Remove the fuel injection control rack by removing screws (A) and (B) and spring (C); then remove the governor fork pivot pin. Account for an O-ring.

■NOTE: Do not loosen or remove screws (D) or (E) or fuel delivery equalization will have to be performed.

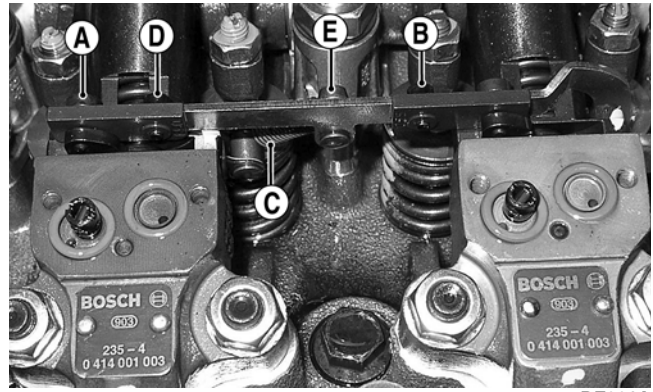

DE291A

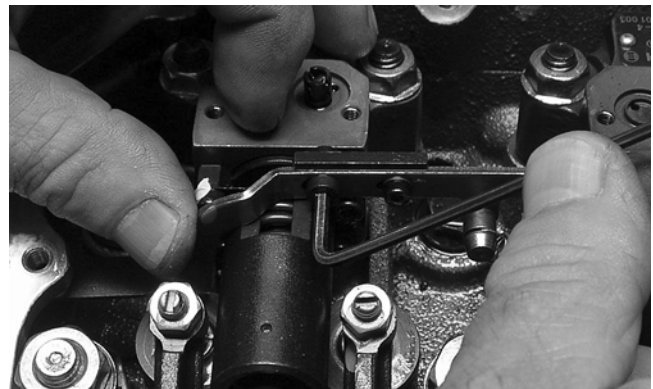

DE327

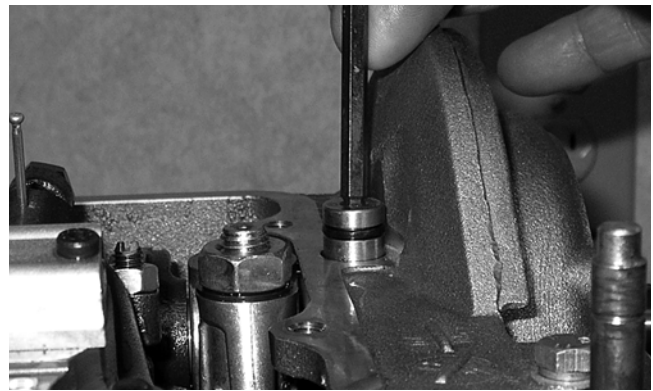

DE282

11. Remove the governor fork and governor spring assembly through the opening on the linkage housing.

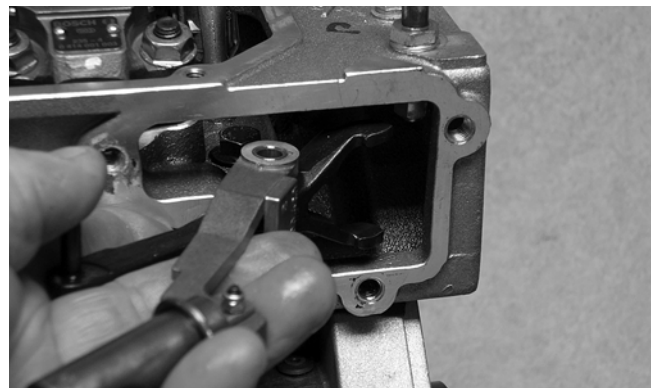

DE253

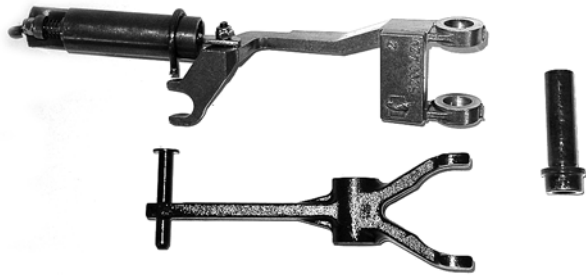

DE254

Inspecting

1. Inspect the flyweight assembly for loose pins, worn contact points, or excessive pivot point wear.

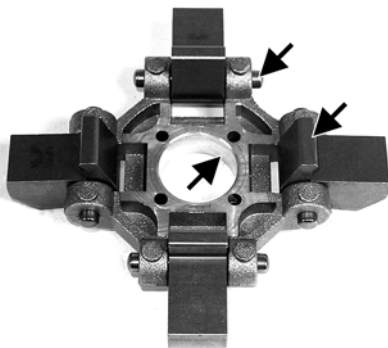

DE247A

2. Inspect all springs, links, and pivot pins for proper tension, excessive wear, or loose fit.

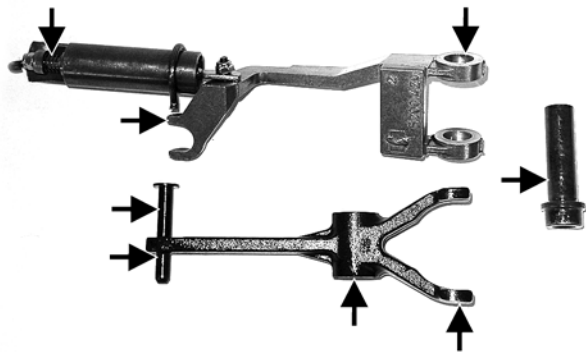

DE254A

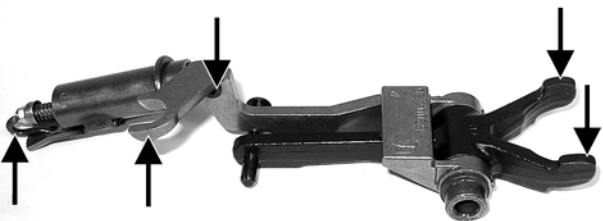

DE256A

3. Inspect the control spool, thrust bearing, and thrust washer for scoring, excessive wear, or missing bearing rollers.

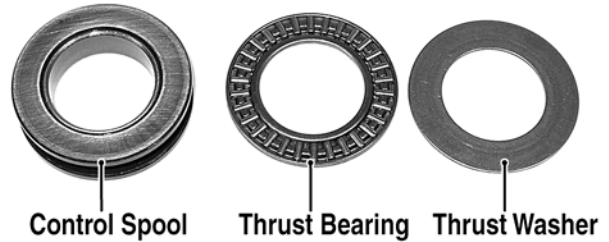

DE278A

4. Coat all serviceable parts with clean engine oil.

Assembling/Installing

1. Install the governor fork assembly into the cylinder head and secure with the governor fork pivot pin. Tighten securely.

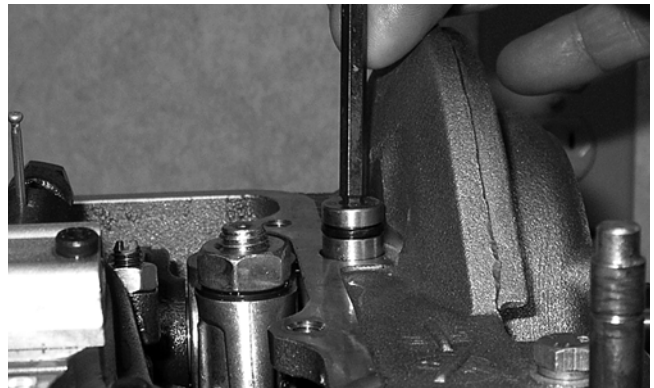

DE282

2. Using a new copper washer, install the torque setting screw assembly and tighten securely; then install the safety cover. Make sure the torque limiter spool engages the limiter fork.

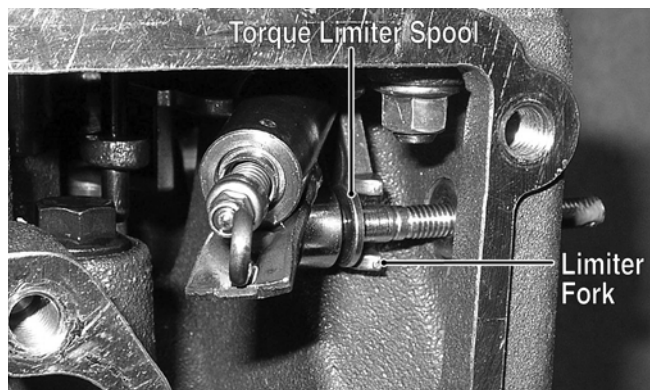

DE288A

3. Using a new gasket, install the intake manifold/throttle control assembly by first connecting the high/low speed spring assembly to the throttle control arm; then place the manifold and gasket into position and secure with the seven cap screws. Tighten securely.

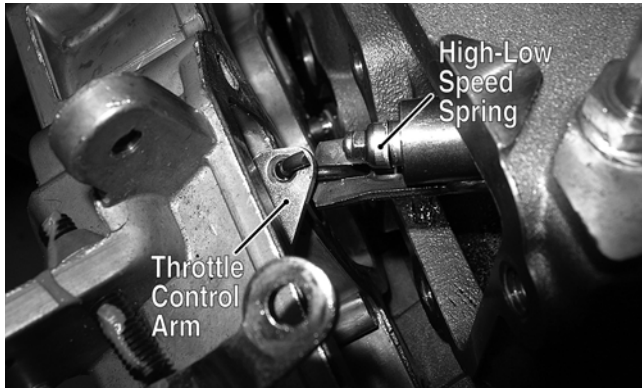

DE258A

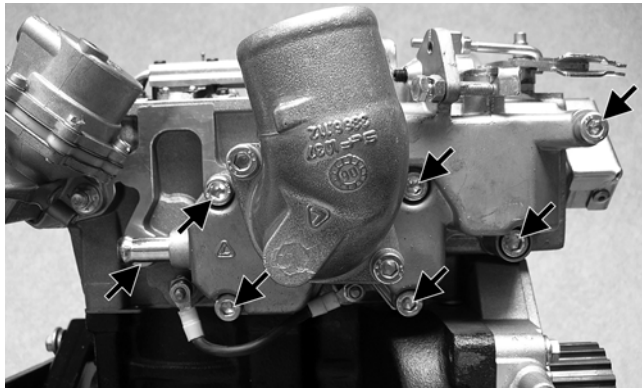

DE248A

4. Install the fuel injector control rack making sure the slotted end engages the governor linkage sleeve; then tighten the cap screws to 11 in.-lb.

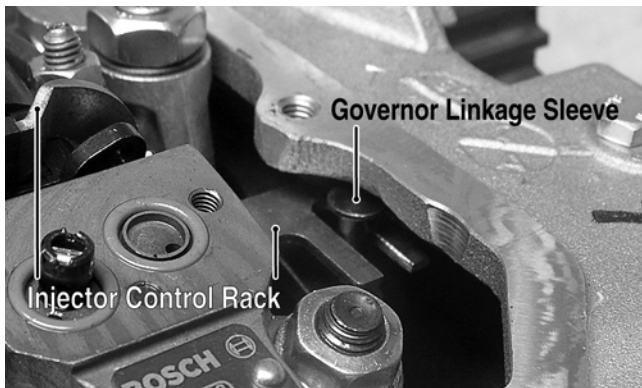

DE534A

5. Connect the throttle linkage into the throttle control lever; then secure with the E-clip.

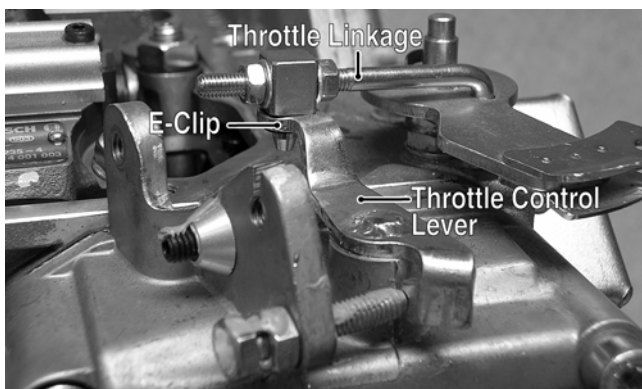

DE249A

6. Place control spool, thrust bearing, and thrust washer into the governor flyweight assembly and secure the flyweights with a rubber band; then place assembly onto the camshaft with a new O-ring. Make sure to remove the rubber band.

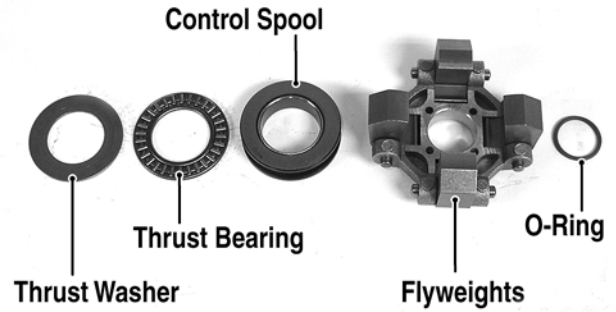

DE279A

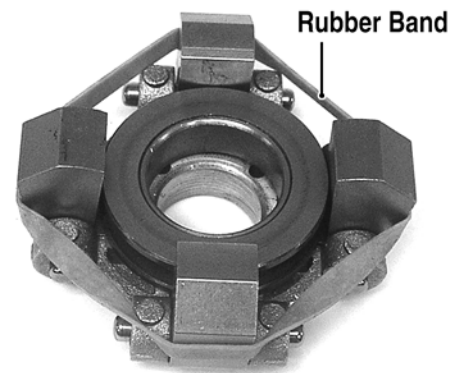

DE531A

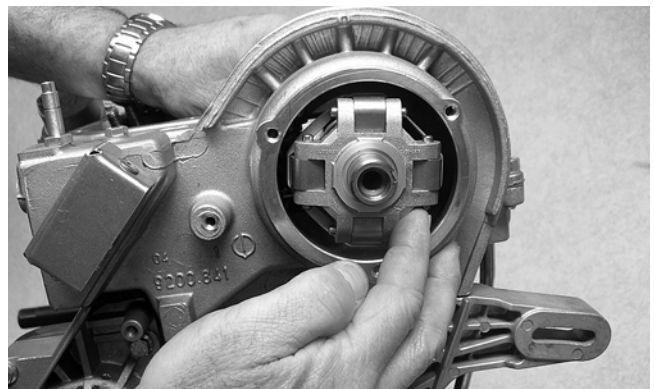

DE535

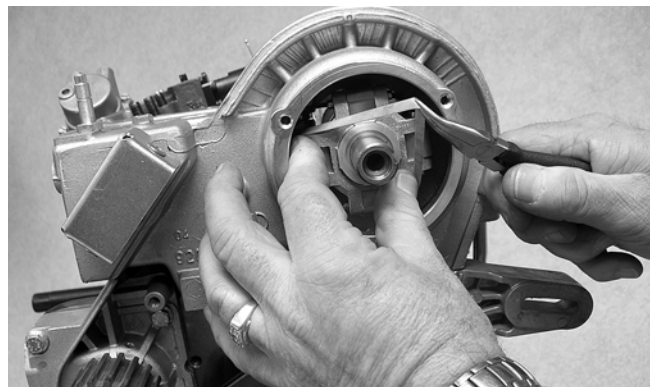

DE536

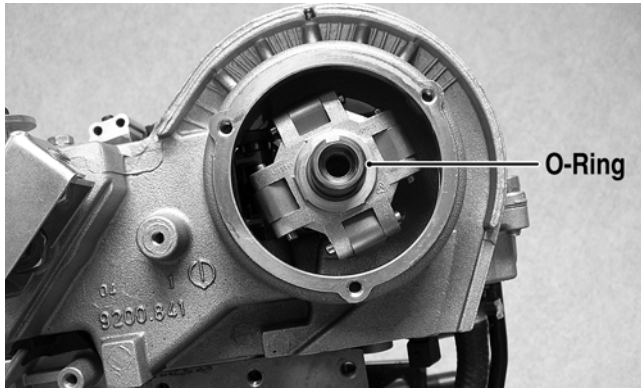

DE246A

7. Using a new O-ring, coat the flange of the camshaft bearing retainer and the camshaft support housing with clean engine oil and install into the cylinder head. Secure with the three cap screws and tighten to 7 ft-lb.

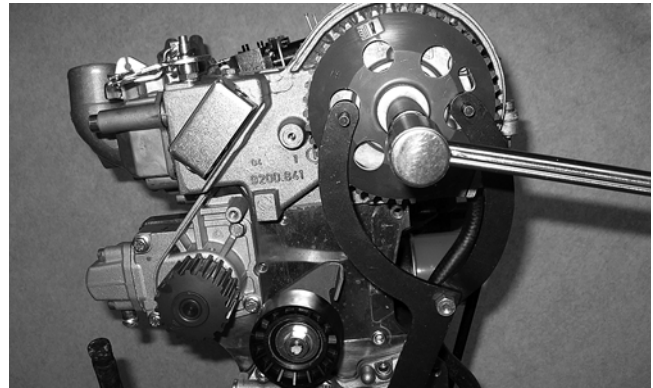

DE262

10. Install the timing belt (see Left-Side Components in this section).

11. Install the valve cover using a new gasket; then secure with the ten cap screws and using a crisscross pattern, tighten to 6.5 ft-lb.



DE296

8. Being careful not to damage the oil seal, lightly coat the camshaft drive pulley flange with clean engine oil and install on the camshaft.

■NOTE: The camshaft drive pulley has a molded extrusion in the pulley bore that must engage the keyway in the camshaft.



DE407

CAUTION

Always use a new gasket and drain seal when installing the valve cover. The valve cover gasket is a critical component in the lubrication system. Severe engine damage may occur if the gasket is not replaced.

12. Install the air filter assembly and connect and secure all intake hoses.

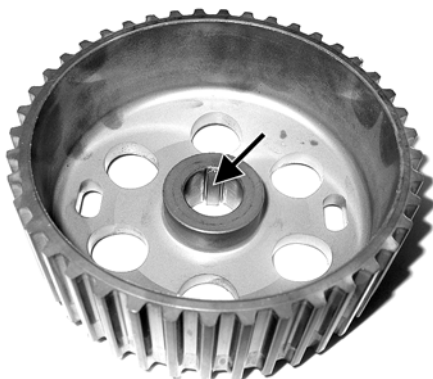

DE574A

9. Secure the camshaft drive pulley to the camshaft with a washer and cap screw; then using an appropriate holding tool, tighten the cap screw to 59 ft-lb.



DE074A

13. Install the front body panel and front rack (see Steering/Frame).

CAMSHAFT/ROCKER ARMS

Removing

1. Remove the timing belt (see Left-Side Components in this section).
2. Remove the front rack and front body; then remove the air filter assembly and mounting bracket, and air diverter with ducts.

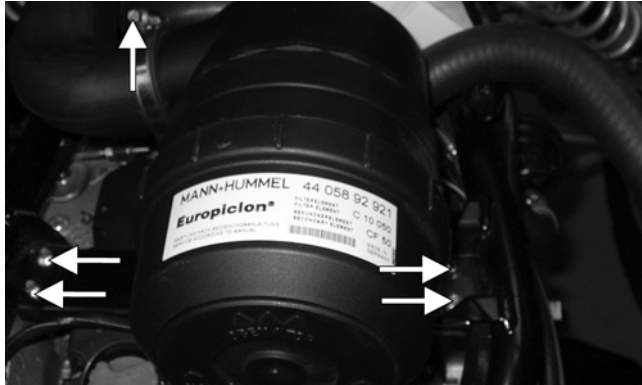

DE074A



DE516A

3. Use duct tape to cover the engine air intake boot to prevent dirt or debris from entering the engine.
4. Disconnect the oil pressure switch connector from the switch located on the right side of the valve cover; then remove the fuel lift pump (see Lift Pump in Fuel/Lubrication/Cooling).



DE077B

5. Disconnect the crankcase breather hose from the right front corner of the valve cover.



DE294A

6. Remove the fuel hoses from the fuel rail; then plug or close off the hoses to prevent fuel leakage.

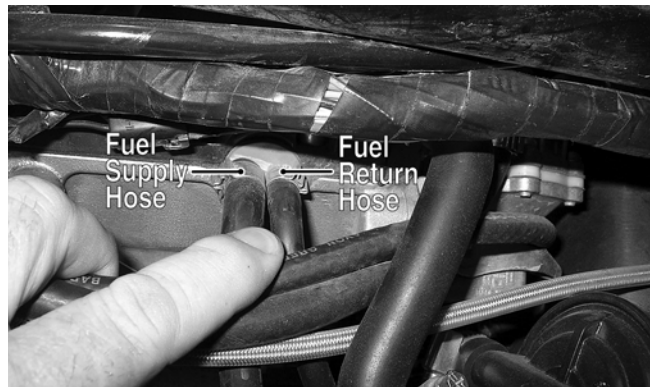

DE295A

7. Remove eight Allen-head and two "tamper-proof" torx-head cap screws securing the valve cover; then remove the valve cover. Account for a gasket and oil return boot.

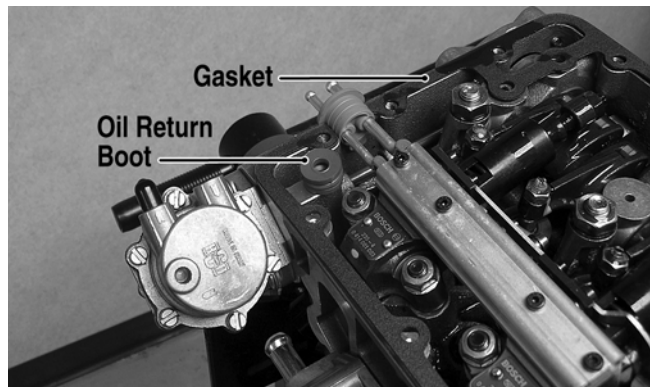

DE405B

■ **NOTE:** "Tamper-proof" cap screws can be removed using Torx-Head Screwdriver - #30.

8. Rotate the crankshaft 90° clockwise from the TDC position to prevent valve damage when turning the camshaft; then rotate the camshaft until one of the unit injector push rods is fully extended into the injector pump barrel.

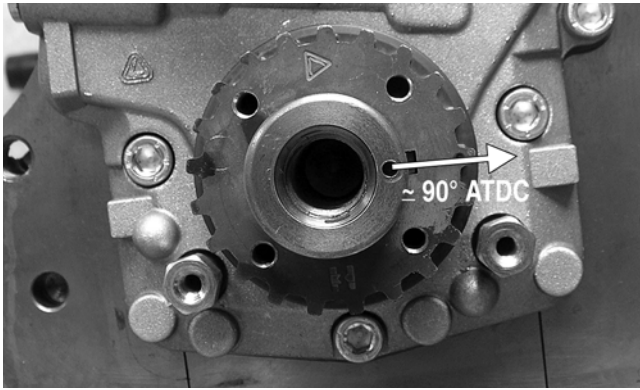

DE275A



DE260C

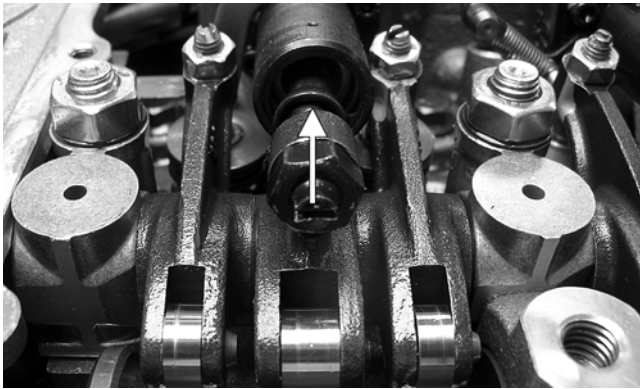

DE404A

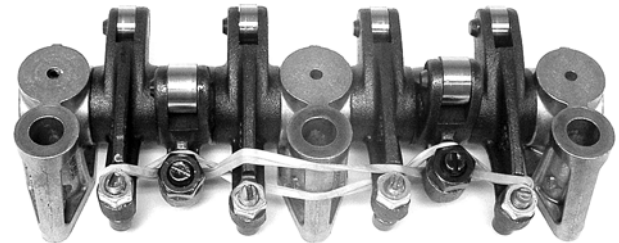

DE529

9. Place a holding pin into the injector pump barrel; then rotate the camshaft until the second injector is fully compressed and install a holding pin.

11. Using an appropriate holding tool, remove the cap screw securing the camshaft drive pulley to the camshaft; then remove the pulley.

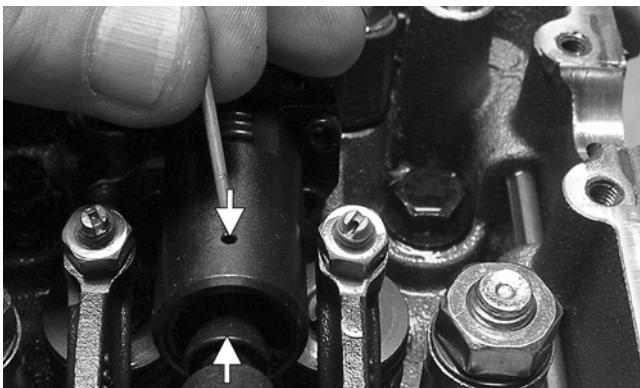

DE328A

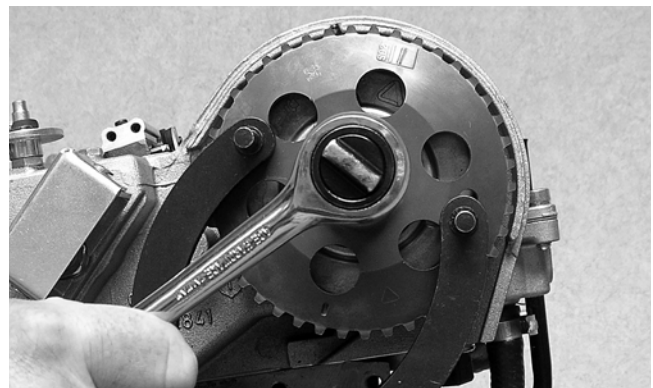

DE276

10. Remove the three nuts securing the rocker arm assembly to the cylinder head; then using rubber bands, bind the rocker arms together and lift the assembly off the mounting studs being careful to keep the injector push rods with the injector it was originally installed in.

12. Remove the camshaft support housing; then remove the speed governor flyweight assembly. Account for an O-ring.

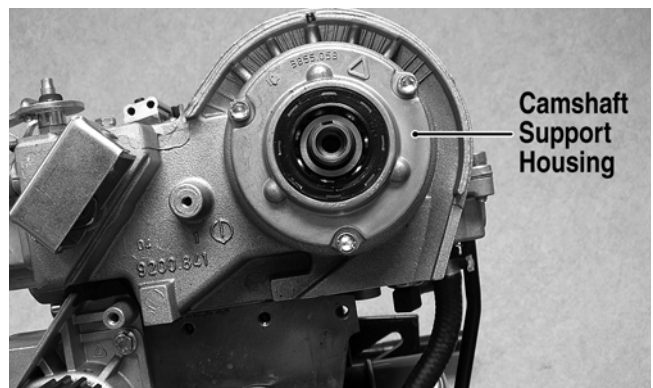

DE245A

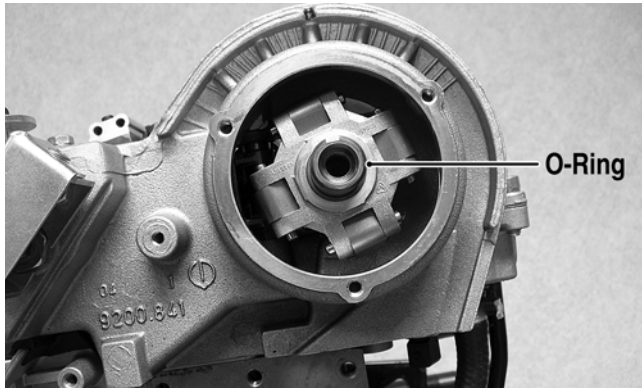

DE246A

- Remove the governor control spool, thrust bearing, and thrust washer keeping all components in order of disassembly.

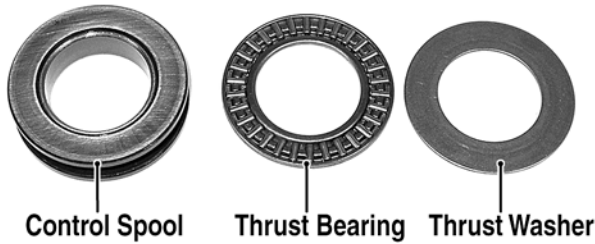

DE278A

- Remove the camshaft end cover; then gently slide the camshaft toward the flywheel end of the engine. Rotate the camshaft slightly to prevent binding and hanging in the camshaft bores. Account for the fuel pump eccentric bushing.

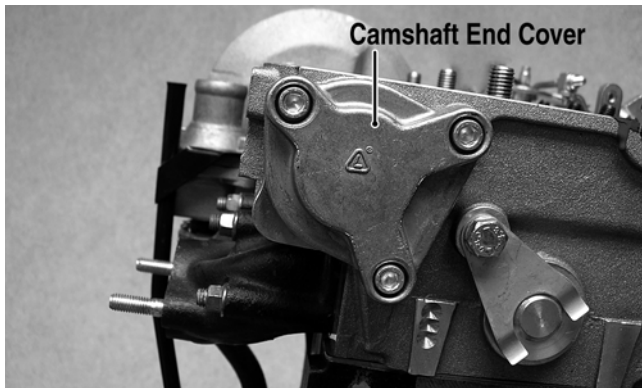

DE297A

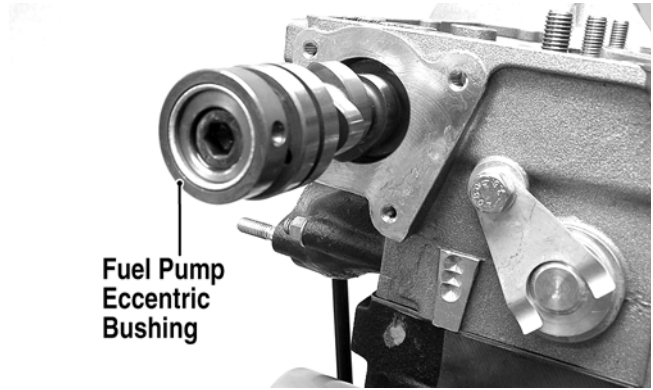

DE299A

CAUTION

Make sure to support the camshaft while the journals are pulled clear of the journal bores or damage to journal bores may occur.

Inspecting

- Thoroughly clean the camshaft in parts-cleaning solvent; then dry with compressed air.

WARNING

Always wear safety glasses when working with compressed air.

- Inspect each camshaft journal for scoring, heat discoloring, or pitting.

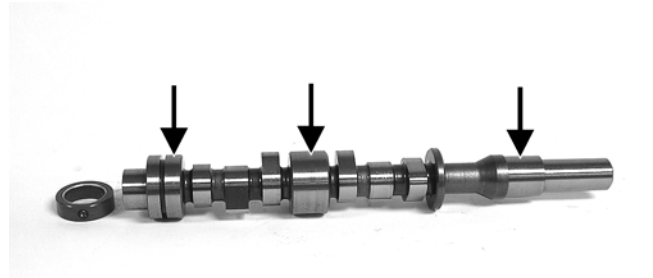

DE298A

- Inspect all camshaft lobes for scoring, galling, flaking, or pitting.

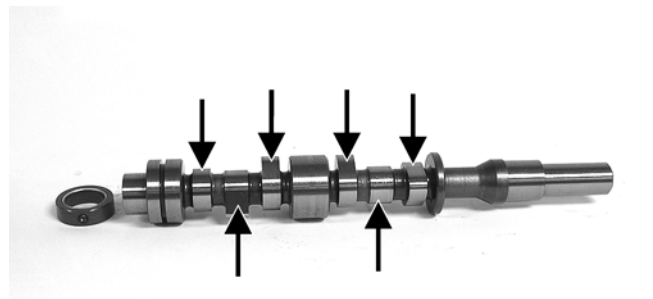

DE298B

- Inspect the fuel lift pump eccentric and bushing for excessive wear, scoring, or pitting.



DE524

5. Inspect rocker arms, camshaft followers, and rocker shaft for excessive wear, broken or scored rollers, or cracked rocker arm shaft supports.



DE522



DE523

7. Using a micrometer, measure and record camshaft intake, exhaust, and injection lobe height. Measurements must not be less than minimum specifications.



DE546A

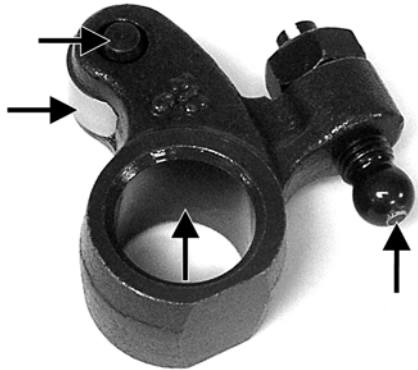

DE547A



DE527

8. Using an inside micrometer, measure the camshaft journal holder diameter. Measurement must not exceed the maximum specifications.

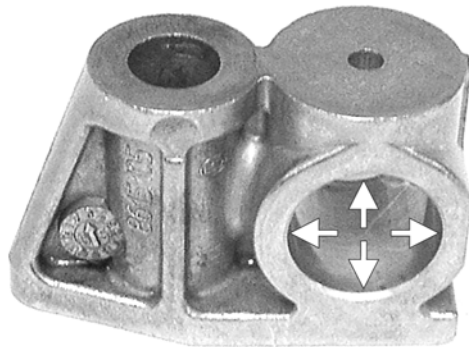

DE528A

6. Using a micrometer, measure and record camshaft journal diameter. Measurement must not be less than minimum specification.

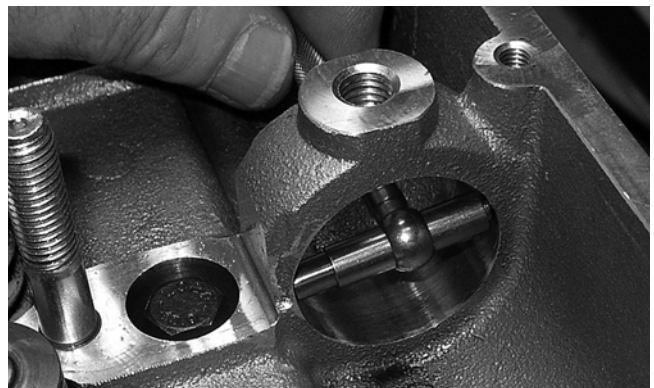

DE541

■NOTE: If the rocker arm assembly is to be disassembled, label all rocker arms for installing purposes. If the rocker arms are mixed up, the complete overhead must be adjusted.

9. After labeling rocker arms and supports, remove components from the rocker arm shaft.
10. Inspect the wear points on the rocker arm shaft and using a micrometer, measure the shaft. The measurements must be within specifications.



DE542

11. Measure the inside diameter of the rocker arms. The measurement must be within specifications.



DE544

12. Inspect all components for cracks, flaking, galling, or signs of discoloration.
13. Assemble the rocker arm assembly installing the rocker arms and supports in the original positions as removed coating all components with clean engine oil. Hold components in place with rubber bands.

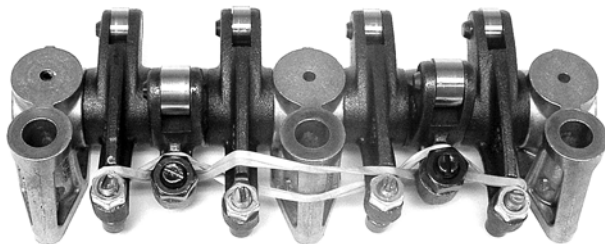

DE529

Installing

■NOTE: The flywheel end of the camshaft includes a bolt-on eccentric to drive the lift pump. If the eccentric has been removed, install and tighten the cap screw to 59 ft-lb.

1. Coat the camshaft journals, lobes, and camshaft bores in the cylinder head with clean engine oil; then carefully insert the camshaft into the cylinder head being careful not to nick or jam journals or journal bores.

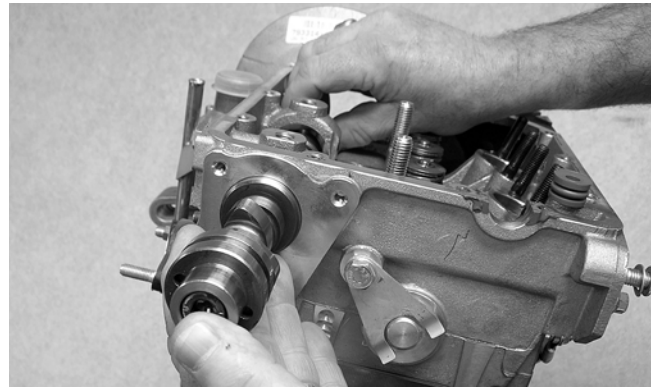

DE525

2. Install the lift pump eccentric bushing onto the camshaft; then install the camshaft end cover using a new O-ring. Tighten the cap screws securely.

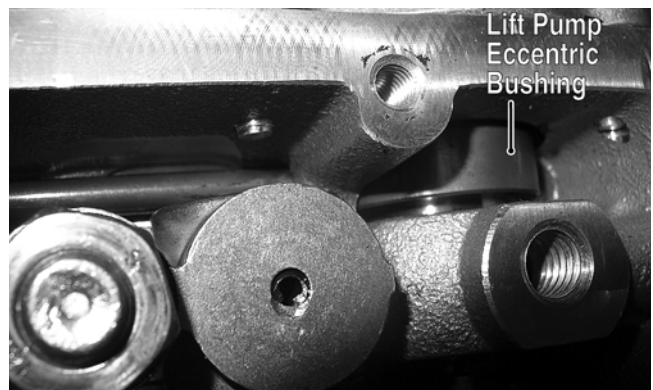

DE540A

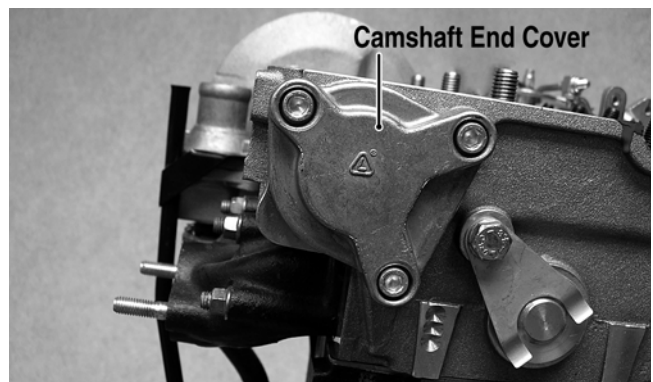

DE297A

3. Insert the lift pump push rod and engage the eccentric bushing; then using a new sealing ring, install the lift pump and tighten the mounting nuts securely.

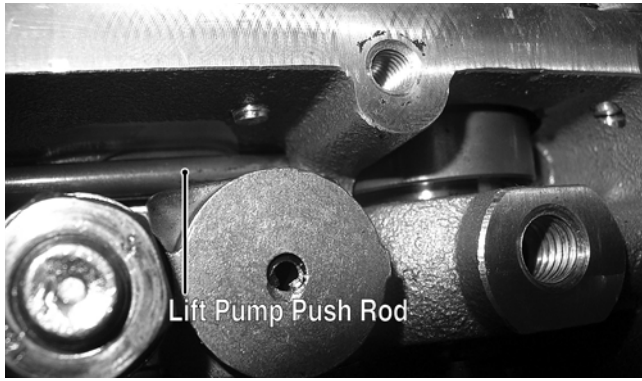

DE540B

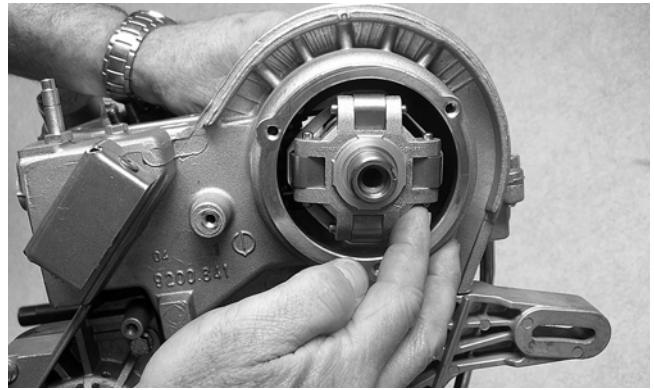

DE535

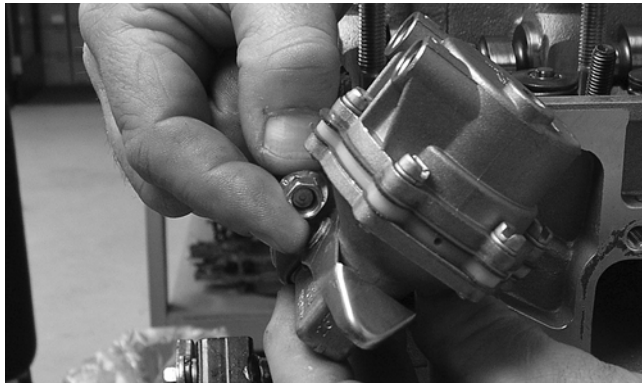

DE530

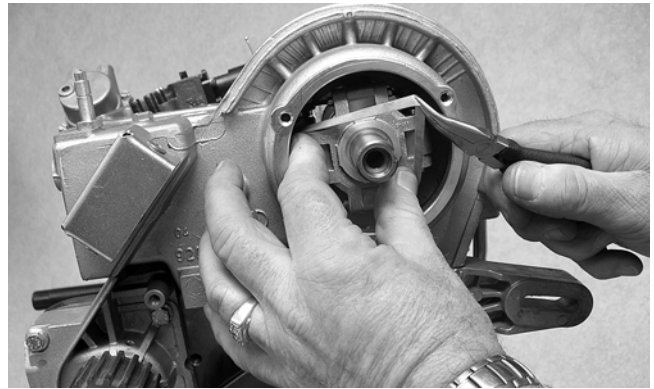

DE536

4. Place the control spool, thrust bearing, and thrust washer into the governor flyweight assembly; then using a rubber band, secure the weights around the control spool.

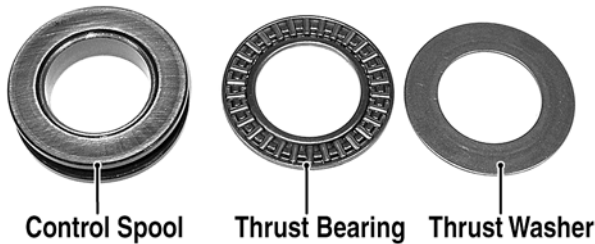

DE278A

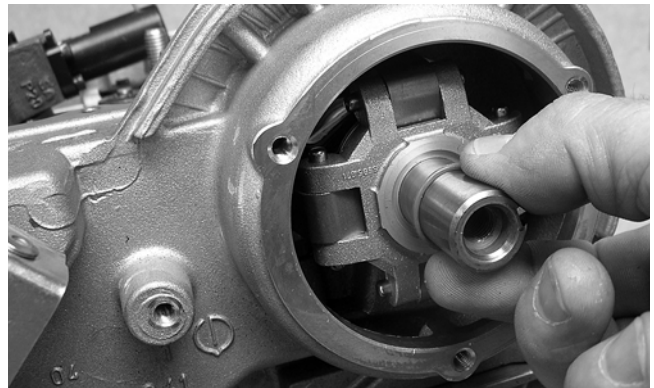

DE537

6. Using a new O-ring, install the camshaft support housing and tighten the cap screws to 7 ft-lb.

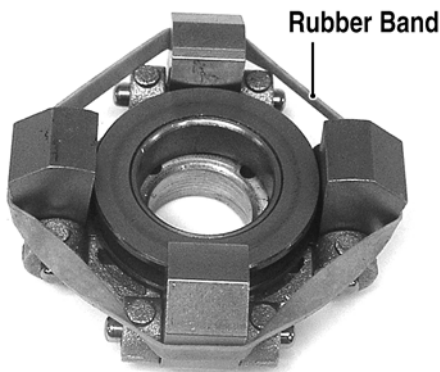

DE531A

5. Apply clean engine oil to the governor assembly and install on the camshaft; then hold the flyweight assembly and remove the rubber band. Install a new O-ring on the camshaft.

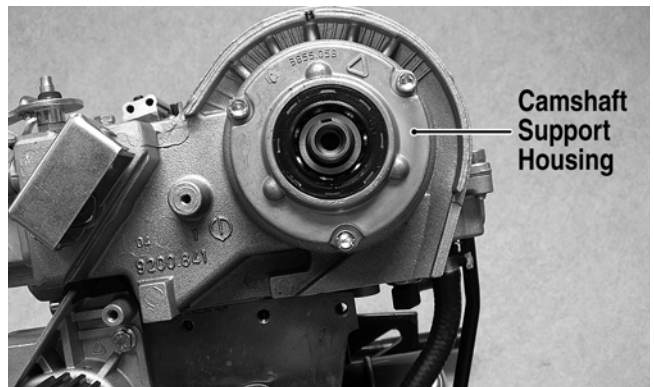

DE245A

7. Install the camshaft drive pulley and cap screw; then using a suitable holding tool, tighten the cap screw to 59 ft-lb.

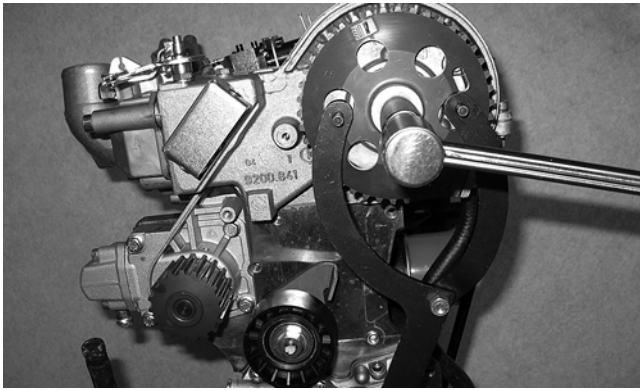

DE262

⚠ AT THIS POINT

If the cylinder head has been removed, no more components may be installed prior to installation on the engine block. If the cylinder head has not been removed, proceed to step 8.

8. Lubricate all rocker shaft components with clean engine oil; then install the rocker arm assembly on the cylinder head making sure the injector push rods are correctly installed in their respective injectors.

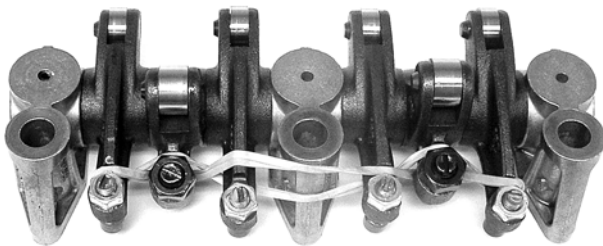

DE529

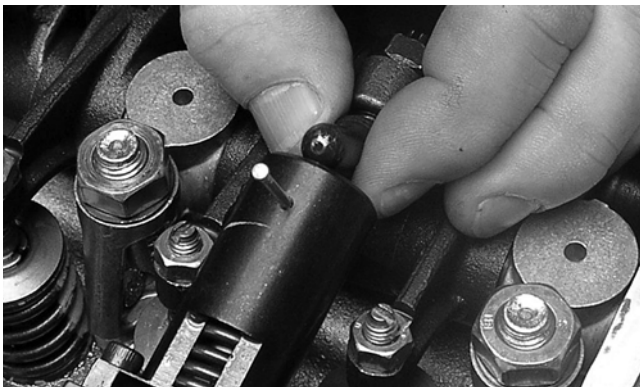

DE571

9. Rotate the camshaft until the camshaft lobes are facing away from the rocker arms; then secure the rocker arm support with the flat washers and nuts. Tighten to 29 ft-lb.



DE260C

10. Install the timing belt (see Left-Side Components in this section).
11. Check adjustment of all valves (see Top-Side Components in this section).
12. Place a small bead of high-temperature sealant on both sides of the fuel rail seal; then carefully install the valve cover with a new gasket and oil return boot. Secure with existing hardware.

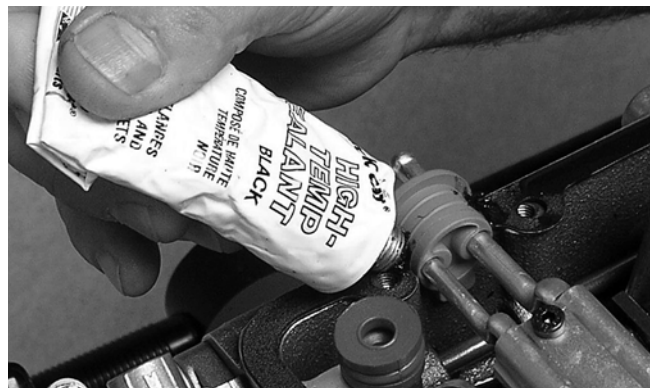

DE451

13. Using a crisscross pattern, tighten the Allen-head cap screws to 6.5 ft-lb; then tighten the two "tamper-proof" torx-head cap screws to 6.5 ft-lb.
14. Connect the fuel hoses to the fuel rail; then connect the crankcase breather hose.

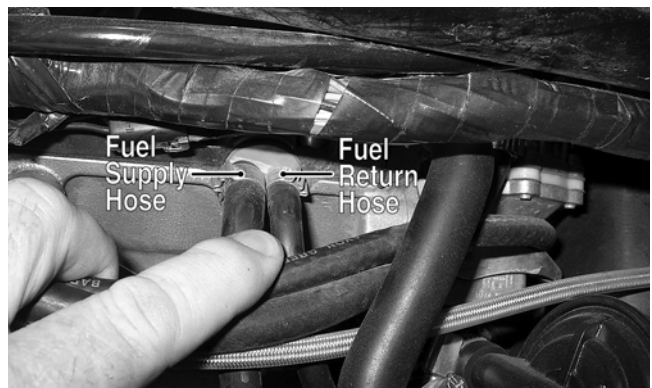

DE295A

15. Connect the oil pressure switch connector to the oil pressure switch.



DE077B

16. Install the air filter assembly; then remove the tape from the engine air intake boot and connect the air intake boot. Tighten the boot clamp securely.
17. Install the air diverter and connect the air boots. Tighten the clamps securely.
18. Install the front body; then install the front rack (see Steering/Frame).

UNIT INJECTORS

Removing

1. Remove the front rack and front body panel (see Steering/Frame).
2. Remove the air diverter assembly leaving the air intake boots on the ATV; then remove the air filter assembly and mounting bracket.

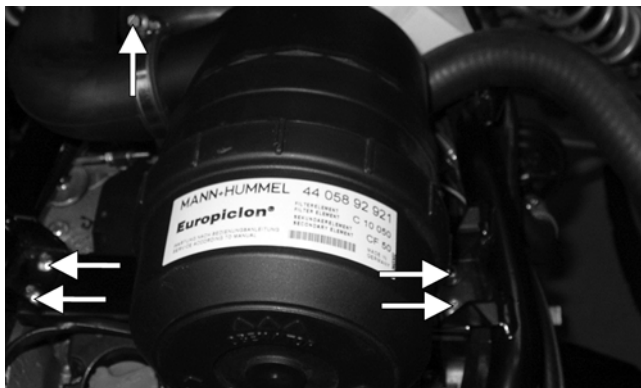

DE074A

3. Use duct tape or another suitable material to cover the engine air intake boot to prevent dirt or other debris from entering the engine.
4. Disconnect the oil pressure switch connector from the switch located on the right side of the valve cover.
5. Disconnect the crankcase breather hose from the right front corner of the valve cover.



DE294A

6. Remove the fuel hoses from the fuel rail; then plug or close off the hoses to prevent fuel leakage.

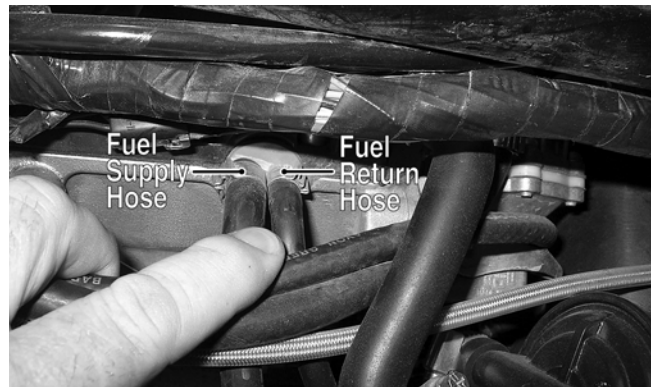

DE295A

7. Remove eight standard torx-head cap screws from the valve cover; then using Torx-Head Screwdriver - #30, remove the two "tamper-proof" torx-head cap screws.
8. Remove four Allen-head machine screws securing the fuel rail to the unit injectors; then remove the fuel rail. Account for four O-rings.

CAUTION

Do not allow dirt and contaminants to enter the diesel fuel system components. Dirt or moisture will cause severe engine/fuel system component damage.

9. Carefully remove the spring from the injection control rack; then remove the Allen-head pivot screws securing the injection control rack to the injection pump fuel controls.

CAUTION

DO NOT loosen fuel delivery adjustment screws or extensive adjustment will be necessary.

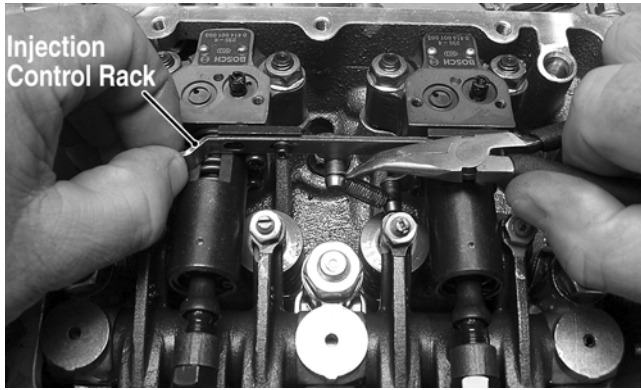

DE292A

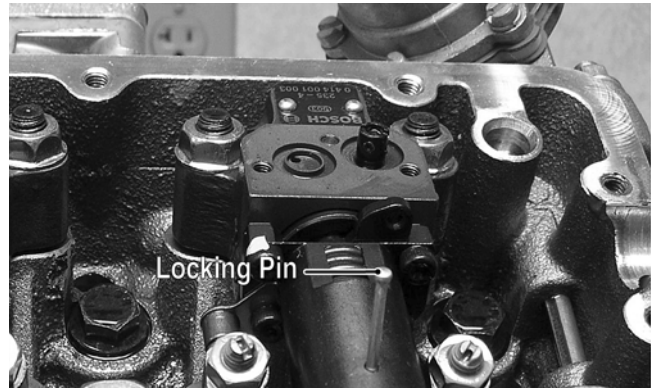

DE329B

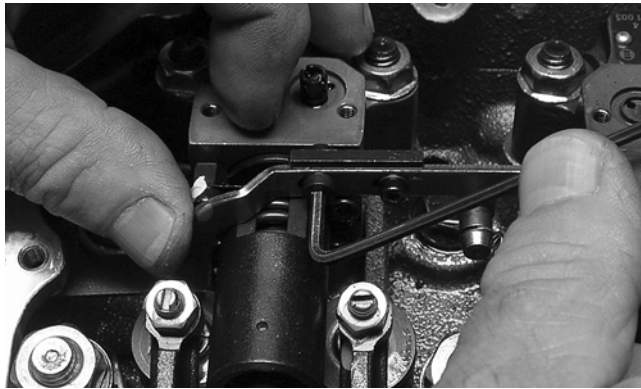

DE327

10. Remove the injection control rack by carefully disengaging it from the governor linkage sleeve.

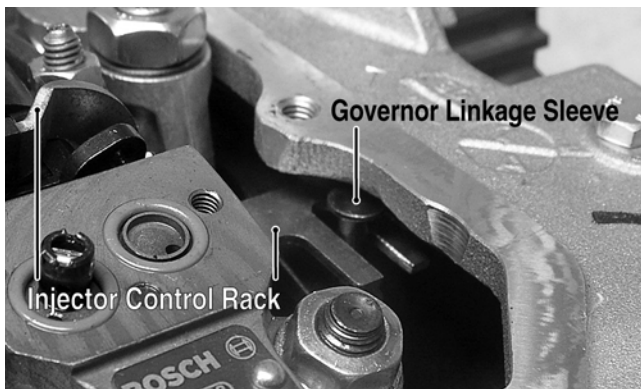

DE534A

11. Rotate the engine until the injector lobe forces the camshaft follower to its highest position; then insert a hardened locking pin into the hole in the injector pump barrel.

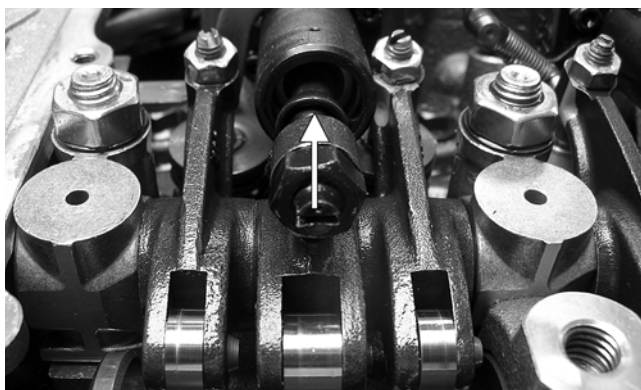

DE404A

CAUTION

DO NOT loosen the jam nut or the injector timing adjustment screw. This will require timing the injector.

12. Repeat step 11 for the second injector. Account for a flame washer and copper washer for each injector.

Servicing

Proper servicing of fuel injection components requires a number of special instruments, special training, and an extremely clean environment (clean room); therefore, Arctic Cat recommends injector service be performed by a qualified diesel injection service facility.

Installing

1. Thoroughly clean the injector bores in the cylinder head; then dry with compressed air.

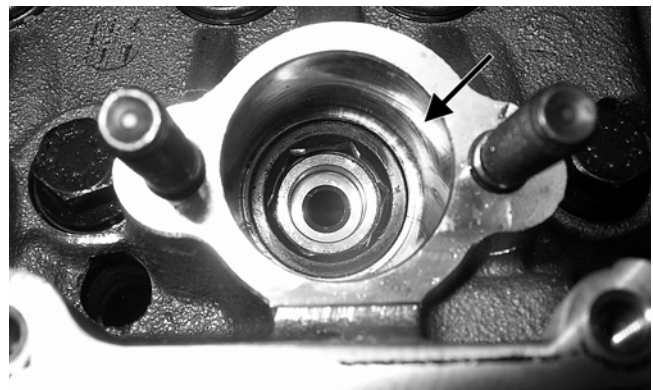

DE567A

⚠ WARNING

Always wear safety glasses when using compressed air.

■ **NOTE:** A small round wire brush can be used to clean injector bores and seating surfaces.

2. Clean the unit injector with a soft wire brush being careful not to damage the injector tip.

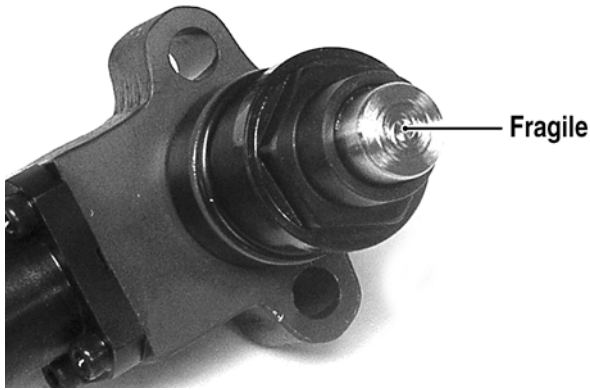

DE565A

3. Measure the injector nozzle protrusion (A). Measurement should be 6.80-7.05 mm (0.268-0.277 in.). Excessive protrusion may be corrected by installing supplemental washers available in 0.25 mm (0.001 in.) sizes along with the standard copper washers (B).

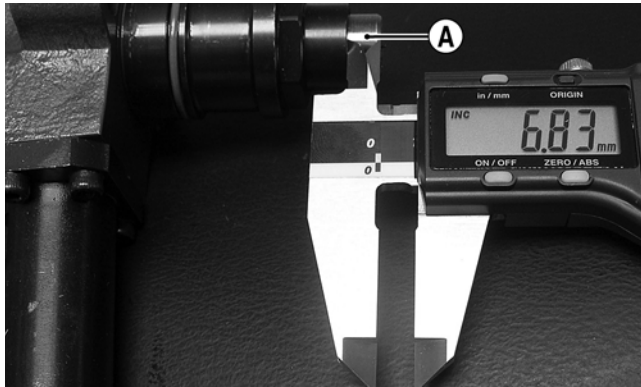

DE566A

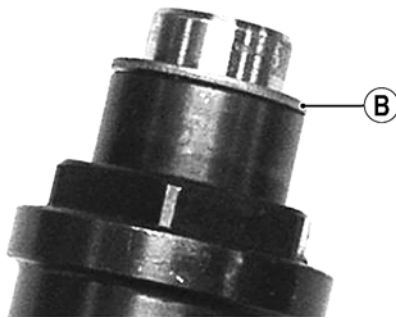

DE570A

4. Clean the fire ring sealing surface in the cylinder head taking care not to damage the pre-combustion cup ring nut.

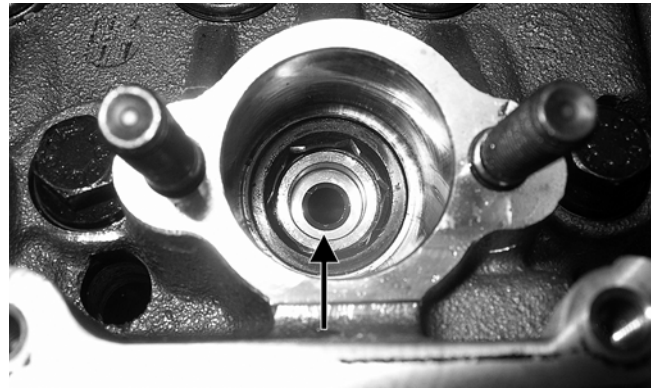

DE567B

5. Clean the fire ring sealing surface on the injector tip taking care not to damage the injector tip.

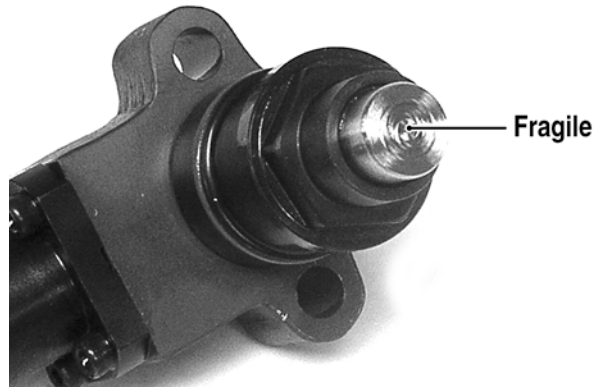

DE565A

■NOTE: A soft brass wire brush is recommended for cleaning injector seating surfaces.

6. Orient the flame washer so the double ribs are directed toward the injector tip; then install the copper washer on the injector.

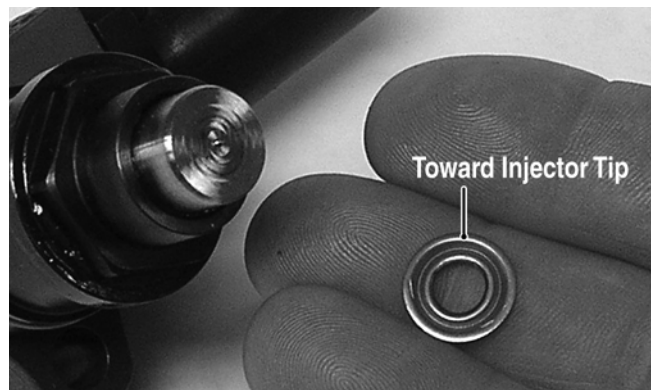

DE569A



DE570

■NOTE: A small amount of lithium grease applied to the washers will aid in keeping them in place on the injector while installing.

7. Install the injector in the cylinder from which it was removed, taking care to avoid dropping the push rod into the engine.

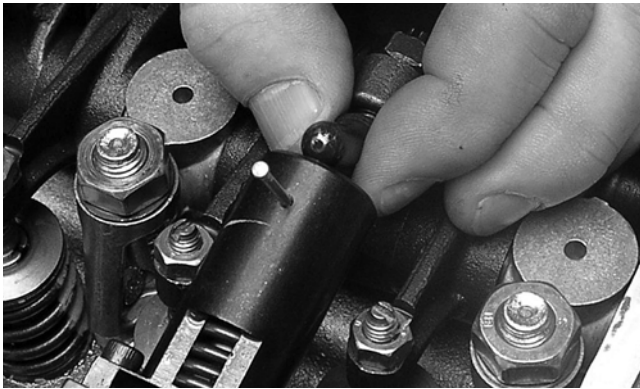

DE571

8. Repeat steps 6 and 7 for the second injector if it was removed.
9. Install the unit injector retainer nuts and tighten in five steps to 15 ft-lb in 3 ft-lb increments.

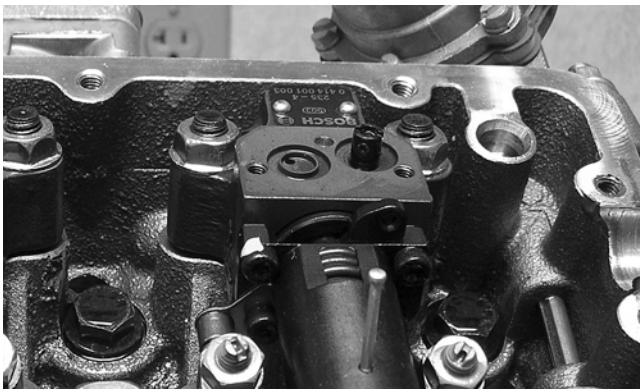

DE329

10. Rotate the engine clockwise to compress the injector push rod sufficiently to remove the hardened pin; then repeat for the second injector.

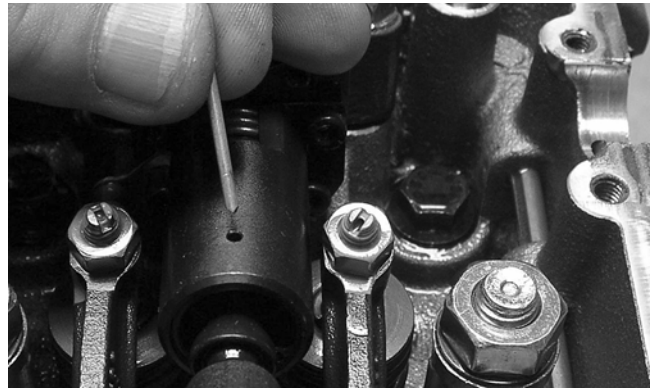

DE328

11. Install the injector control rack by first engaging the governor linkage sleeve; then secure to the injection pump fuel controls with the pivot screws. Tighten to 11 in.-lb.

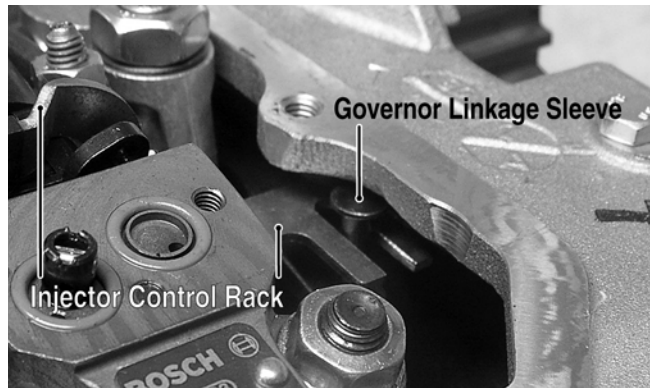

DE534A

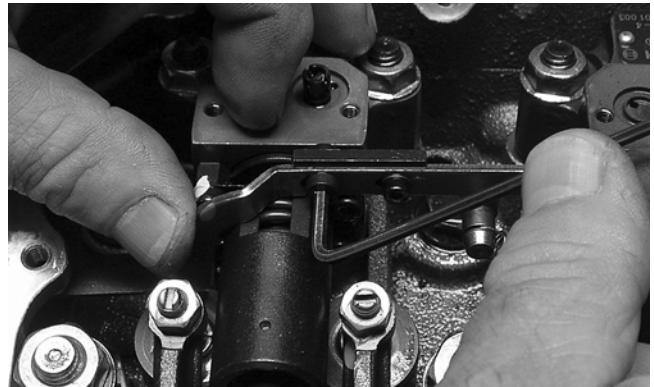

DE327

12. Install the fuel spring.

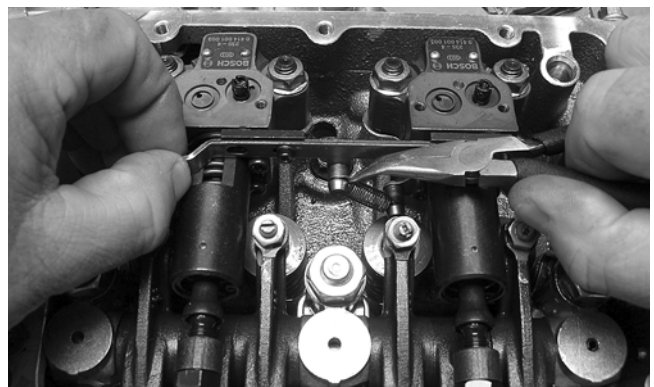

DE292

AT THIS POINT

If injectors were serviced, static injector timing must be set (see Top-Side Components in this section).

- Using new O-rings, install the fuel rail and secure with four Allen-head machine screws. Tighten to 36 in.-lb.

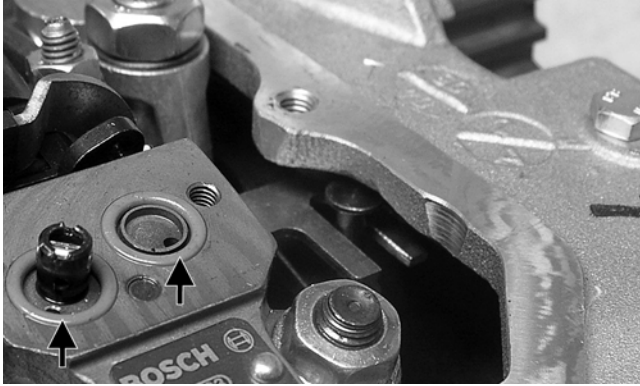

DE534B

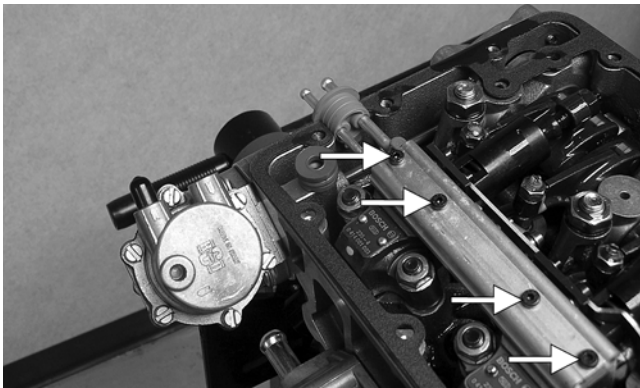

DE405A

- Place a small bead of high-temperature sealant on the fuel rail seal; then carefully install the valve cover with a new gasket and oil return boot. Using a criss-cross pattern, tighten the Allen-head cap screws to 6.5 ft-lb; then tighten the two "tamper-proof" torx-head cap screws to 6.5 ft-lb.



DE406

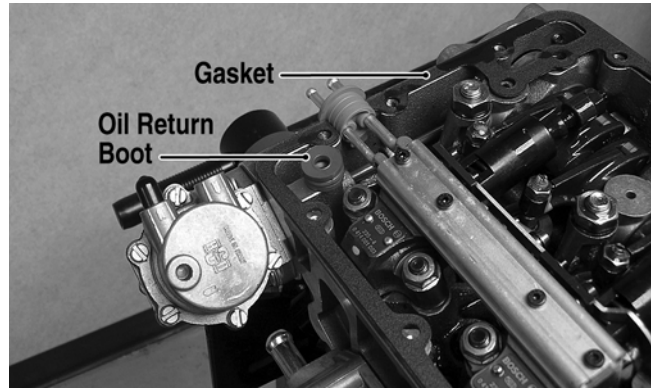

DE405B

CAUTION

The valve cover and gasket are important components in the lubrication system. Improper installation will result in severe engine damage.

- Connect the fuel supply and return hoses to the fuel rail.
- Connect the crankcase breather to the valve cover; then connect the oil pressure switch connector to the oil pressure switch.
- Move the ATV outside or to a well ventilated area; then turn the ignition switch to the ON position and prime the fuel system by pumping the manual primer pump until pressure is felt on the handle.

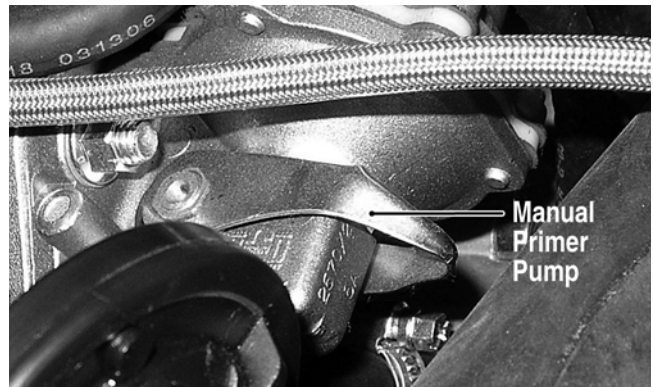

DE031A

- Remove the covering from the air intake hose; then start the engine and check for normal engine operation and look for any fuel or oil leaks.
- Install the air filter assembly and air diverter. Tighten all hose clamps securely.
- Install the front body panel, front rack, and seat (see Steering/Frame).

VALVE CLEARANCE ADJUSTMENT

NOTE: If the engine has been disassembled, proceed to step 4. If the primary objective is to adjust the valves, use the following procedure.

- Remove the front rack and front body panel (see Steering/Frame).
- Remove the air filter assembly; then disconnect the crankcase ventilator hose and oil pressure switch connector from the right-side of the valve cover.

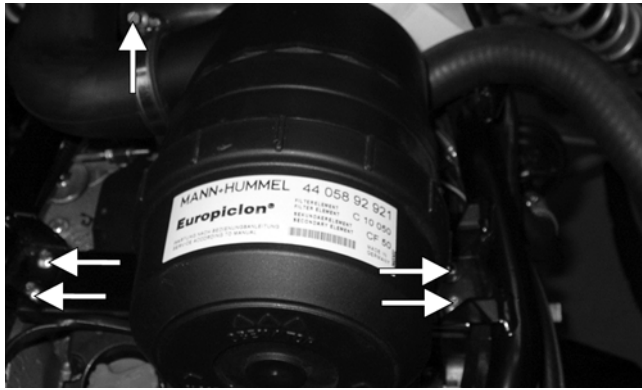

DE074A



DE294A



DE077B

3. Remove the valve cover. Account for a gasket and the oil return boot.

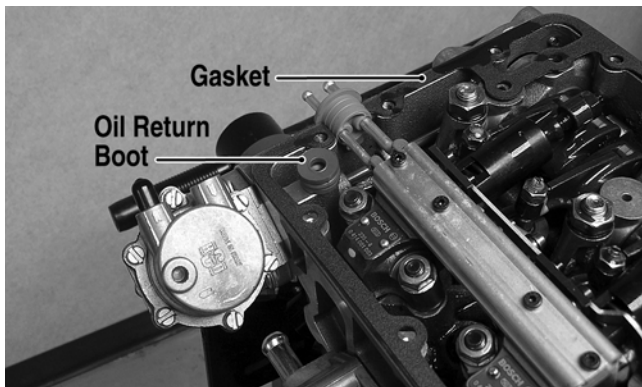

DE405B

NOTE: The valve cover has two “tamper-proof” torx-head cap screws that can be removed by using Torx-Head Screwdriver - #30.

4. Rotate the engine clockwise until either cylinder is at TDC as shown in the following illustration.

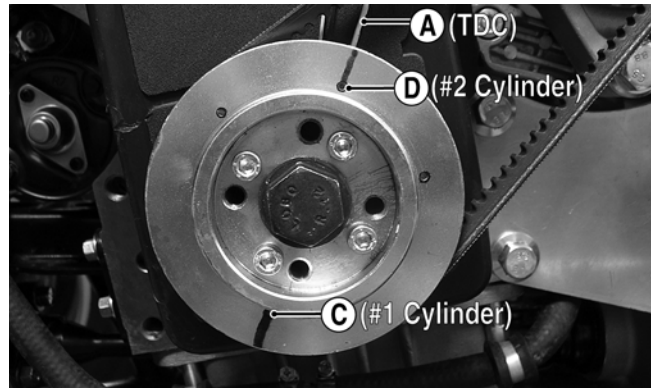

DE557A

5. Using an appropriate thickness gauge, check the clearance between the camshaft follower and camshaft.

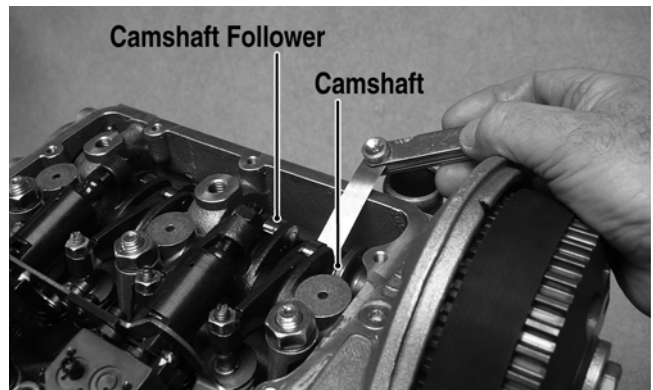

DE642A

6. To adjust the clearance, loosen the jam nut (A); then rotate the adjuster (B) to obtain the specified clearance (C).

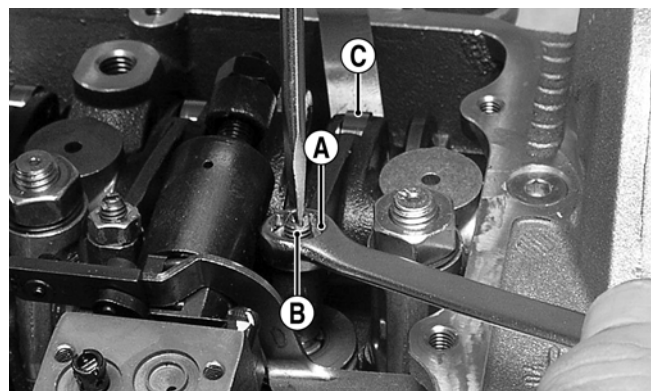

DE429A

7. When proper clearance is attained, tighten the jam nut (A) while holding the adjuster (B); then tighten the jam nut securely and check clearance (C).

8. Rotate the crankshaft clockwise 180° and repeat steps 5-7 on the other cylinder.

AT THIS POINT

If engine is being assembled, static injector timing should be adjusted (see Top-Side Components in this section).

- Place a small bead of high-temperature sealant on the fuel rail seal; then carefully install the valve cover with a new gasket and oil return boot. Using a crisscross pattern, tighten the Allen-head cap screws to 6.5 ft-lb; then tighten the two “tamper-proof” torx-head cap screws to 6.5 ft-lb.



DE406

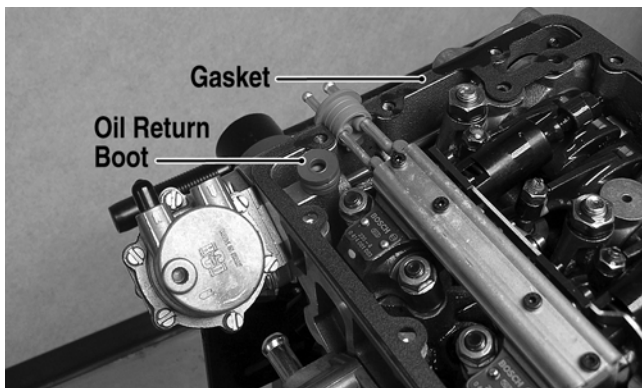

DE405B

- Connect the oil pressure switch connector and the crankcase ventilator hose; then install the air filter assembly and secure with the existing hardware. Tighten securely.

- Install the front body panel; then install the front rack and splash panels (see Steering/Frame).

STATIC INJECTOR TIMING

To set static injector timing, use the following procedure.

- Remove the valve cover and fuel rail (see Unit Injectors in this sub-section).
- Install the Fuel Injector Timing Tool on the injector using the eccentric gasket over the check valve in place of the O-ring.

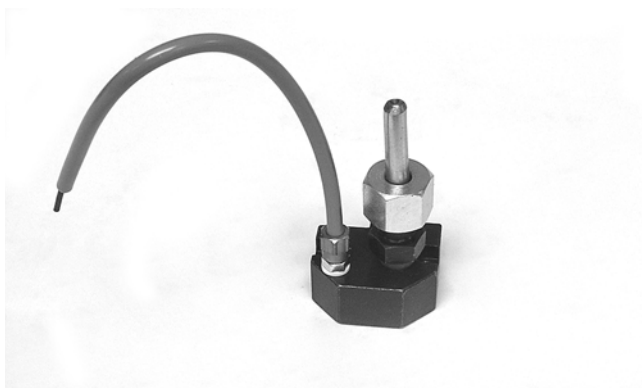

DE572

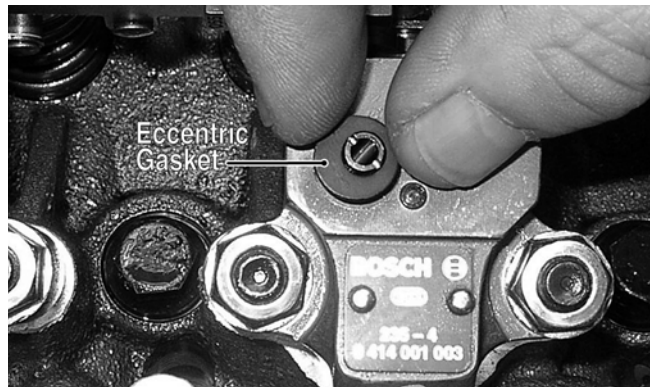

DE444A

- Connect a suitable container filled with clean diesel fuel to the supply fitting using an inlet hose; then place a small cup under the bleed hose.

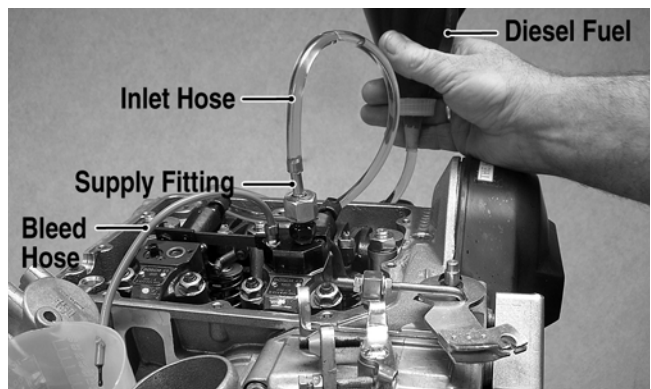

DE403B

- Rotate the engine in the direction of rotation (clockwise) until the #2 (flywheel-side) piston is at top-dead-center (TDC) on the compression stroke (reference mark (D) aligned to TDC index mark (A) and valves closed).

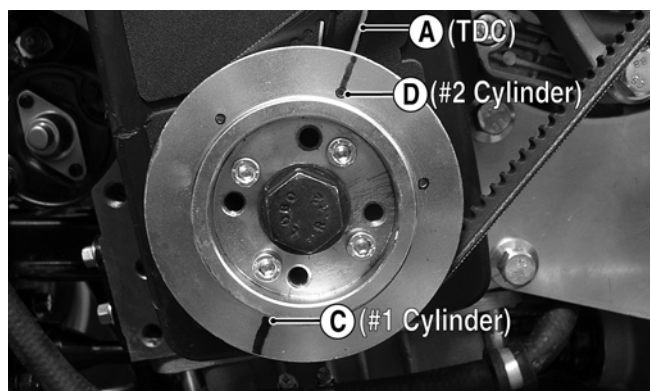

DE557A

- Raise the fuel container above the level of the injector; then rotate engine counterclockwise until reference mark (D) is to the left of the 13° BTDC mark (B) or until fuel is observed flowing from the bleed hose.

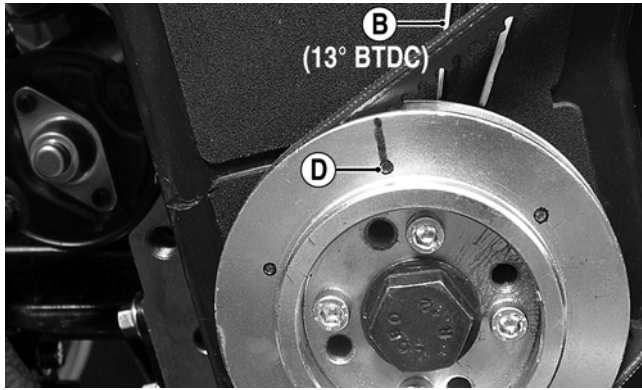

■NOTE: If marks are aligned, timing is correct (proceed to step 9). If marks are not aligned, the injector timing must be adjusted. Adjust injector timing using the following procedure.

8. Observe the position of the reference mark (D) and the 13° BTDC mark (B) and note early or late injector timing.

■NOTE: If the reference mark (D) is left of the 13° BTDC mark (B), injector timing is early. If it is to the right, injector timing is late.

A. Rotate the engine to perfectly align reference mark (D) and 13° BTDC mark (B); then loosen the jam nut on the fuel injector timing adjustment screw. For late timing, proceed to step B. For early timing, proceed to step C.

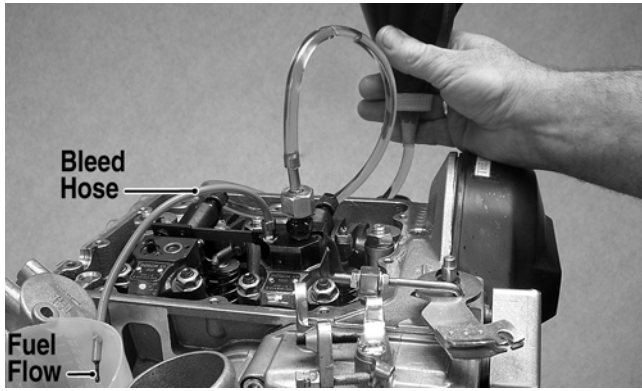

6. Rotate the engine clockwise and stop immediately when the fuel stops flowing. This indicates the beginning of injection.

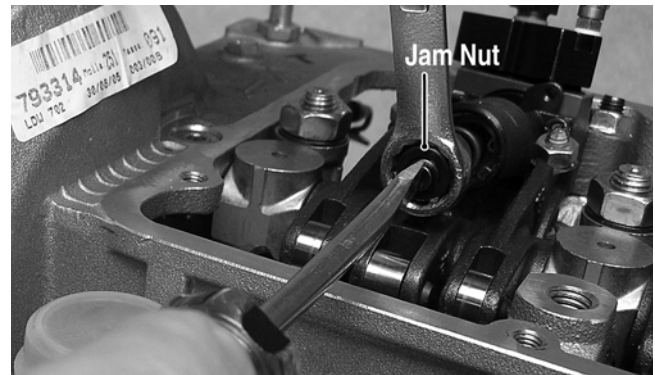

B. While watching the bleed hose, turn the adjustment screw clockwise until fuel flow stops.



7. Observe the alignment of reference mark (D) and the 13° BTDC mark (B).

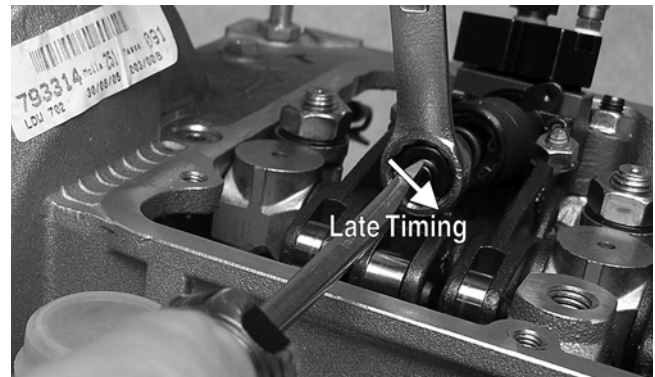

C. While watching the bleed hose, turn the adjustment screw counterclockwise until fuel flow starts (A); then clockwise until fuel flow stops (B).

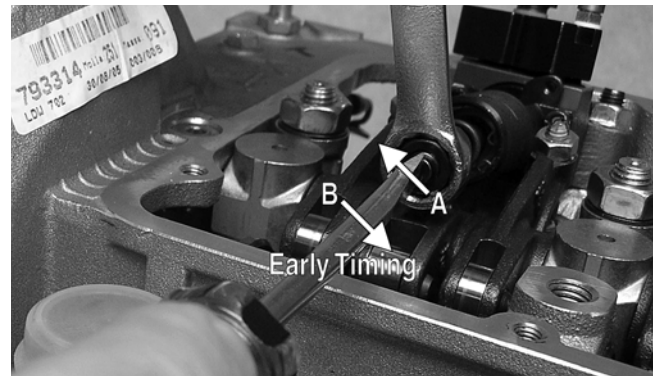
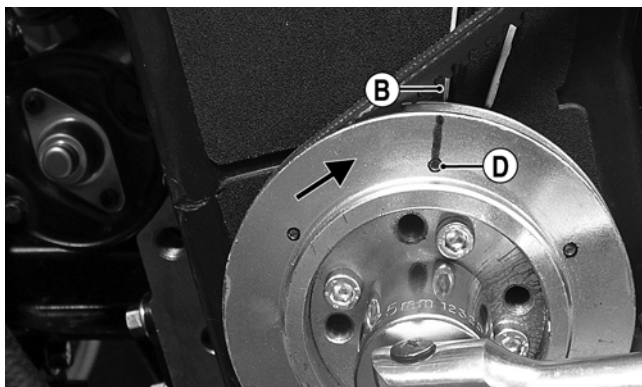

D. Hold the adjustment screw and tighten the jam nut securely; then check the injector timing by repeating steps 5-7.

9. Remove the Fuel Injector Timing Tool and install on the second injector; then rotate the engine 180° clockwise using reference mark (C) and repeat steps 4-8.

AT THIS POINT

If timing is correct for both injectors, proceed to step 10.

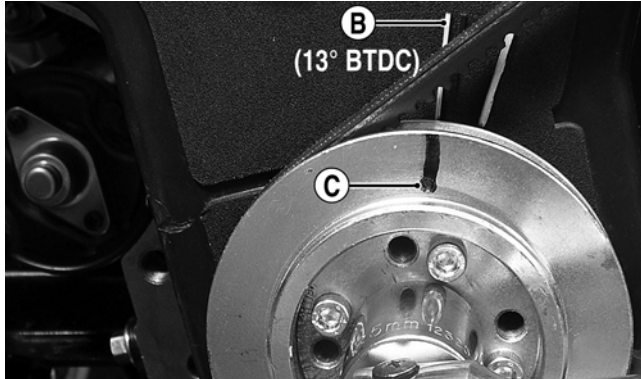

DE563A

10. Remove the Fuel Injector Timing Tool and eccentric gaskets; then install the fuel rail with four new O-rings and tighten the mounting screws to 36 in.-lb.

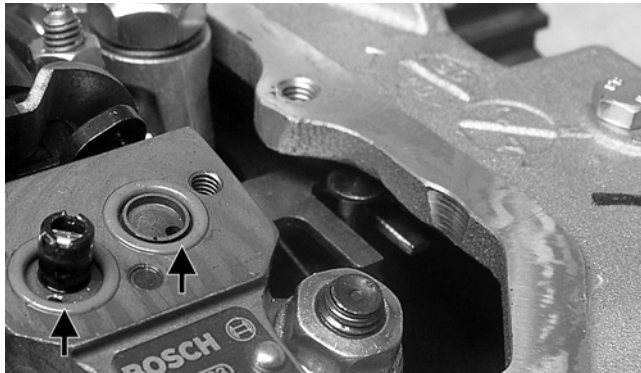

DE534B

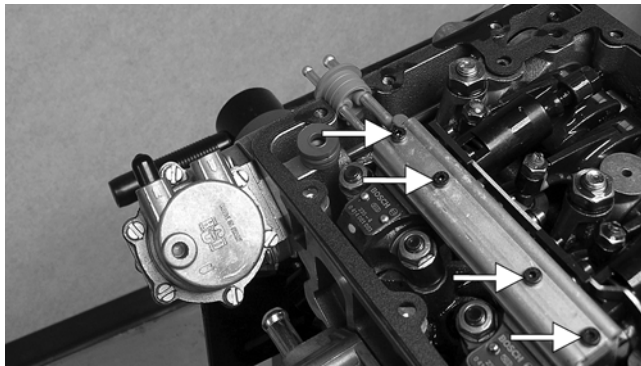

DE405A

11. Install the valve cover using a new gasket and new oil return boot. Tighten the Allen-head cap screws to 6.5 ft-lb using a crisscross pattern; then tighten the "tamper-proof" cap screws to 6.5 ft-lb.

CYLINDER HEAD ASSEMBLY

AT THIS POINT

If the cylinder head or components require servicing, the engine/transmission must be removed.

Removing

1. Remove the engine and transmission (see Removing Engine/Transmission in this section).
2. Secure the engine on a suitable stand.
3. Remove the timing belt (see Left-Side Components in this section).
4. Remove the unit injectors (see Top-Side Components in this section).
5. Remove the lift pump and lift pump push rod (see Fuel/Lubrication/Cooling).
6. Rotate the crankshaft to approximately 90° after top-dead-center (ATDC).

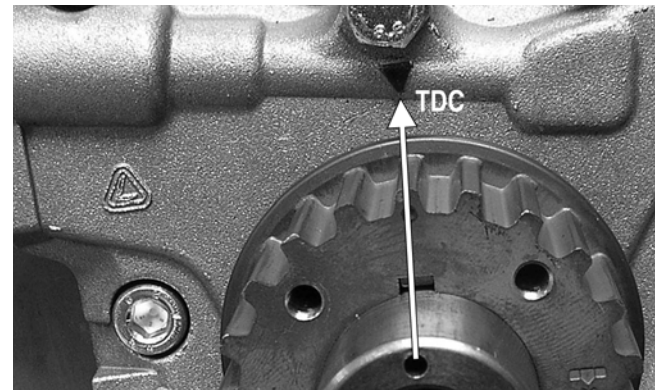

DE240A

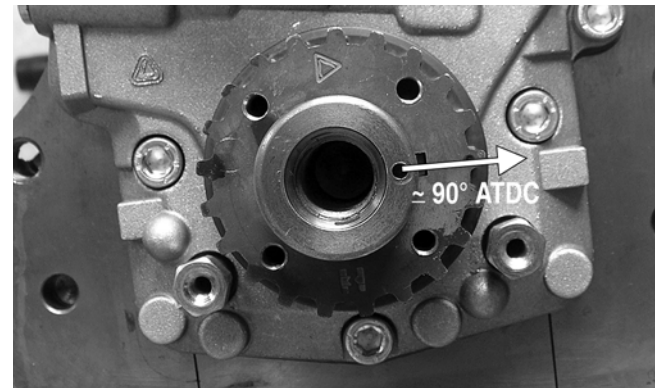

DE275A

7. Turn the camshaft drive pulley until the camshaft and rocker arms are "unloaded" (all rocker arms in "valve-closed" position).

CAUTION

Do not rotate camshaft with the crankshaft in the TDC position or severe engine damage will occur.

8. Remove the three nuts securing the rocker arm shaft; then using rubber bands or a large O-ring secure the rocker arms together.

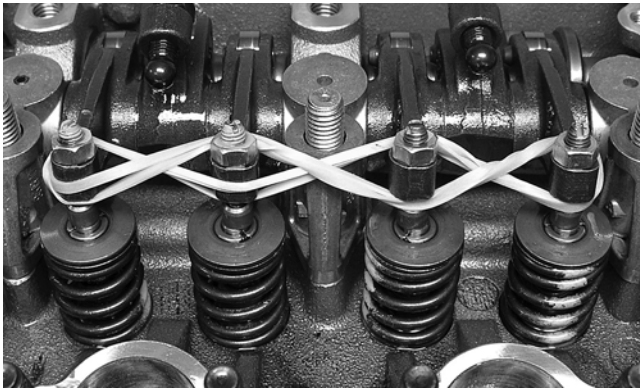

DE307

9. Lift the rocker arm assembly from the cylinder head. Account for three washers.

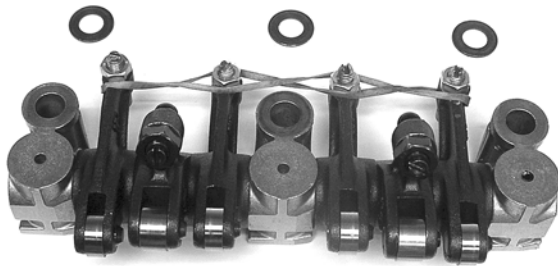

DE584

10. Remove the six cap screws securing the cylinder head to the engine block and remove the cylinder head assembly. Account for six flat washers, a cylinder head gasket, and two alignment pins.

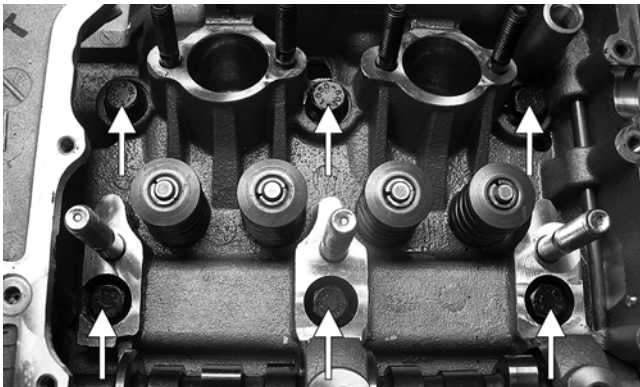

DE575A

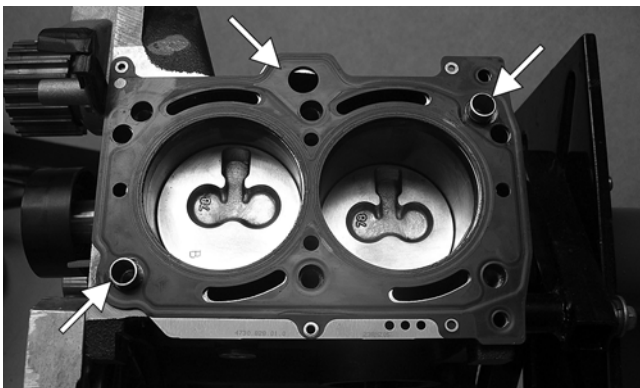

DE577A

AT THIS POINT

If the cylinder head is being removed to allow removal of engine block components, no further disassembling is required. Proceed to Cleaning and Inspecting in this sub-section. If the cylinder head is to be serviced or replaced, proceed to Disassembling in this sub-section.

Disassembling

1. Remove the camshaft (see Camshaft/Rocker Arms in this sub-section).
2. Remove the governor linkage (see Speed Governor in this sub-section).
3. Using a suitable valve spring compressor, remove the valves marking their position for assembly.

■NOTE: It is recommended to keep all individual components in a set, such as valve, valve spring, valve keepers, spring holders, and retainers to aid during assembling.



DE300

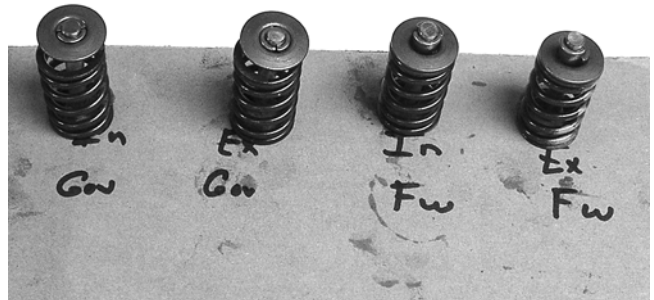

DE315

4. Remove the glow plugs.

AT THIS POINT

The pre-combustion chambers do not have to be removed for general service such as valve replacement, valve seat replacement, or normal cylinder head service. If the pre-combustion chambers must be removed, always replace them with new chambers.

5. Secure the cylinder head using suitable blocks to prevent damage to the pre-combustion chambers; then using the Pre-Combustion Chamber Ring Nut Tool, remove the pre-combustion chamber ring nuts.

Pre-Combustion Chamber Ring Nut Tool



DE310A

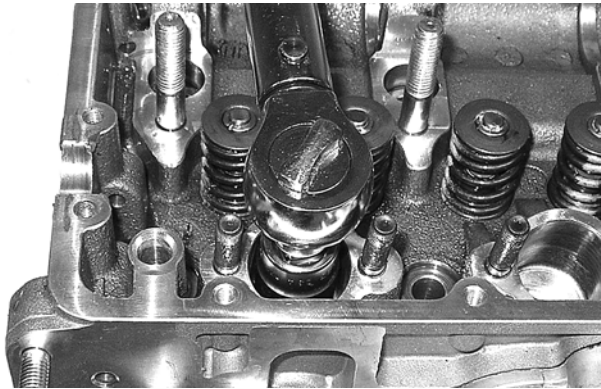

DE324



DE312

6. Install the Pre-Combustion Chamber Removal Tool and slide hammer and remove the pre-combustion chambers from the head.

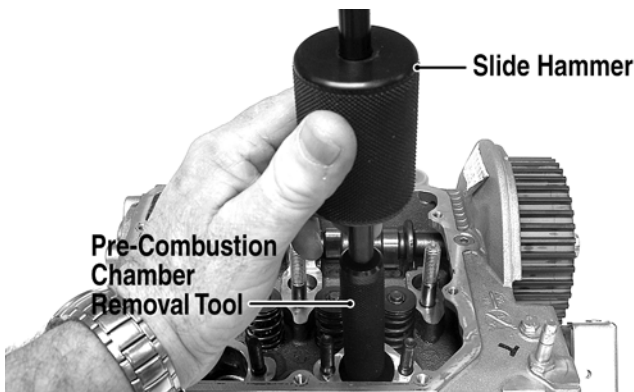

DE579A

CAUTION

Do not attempt to remove the pre-combustion chambers before removing glow plugs. Severe damage WILL occur.

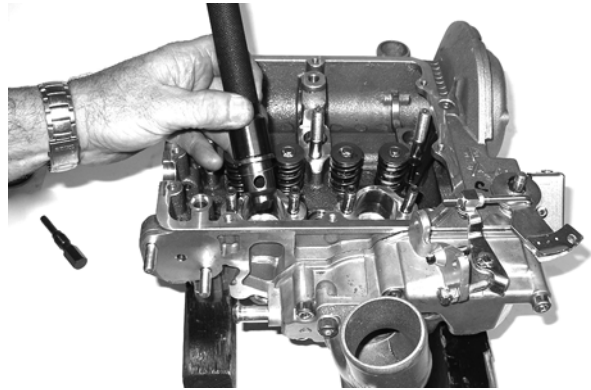

DE321

7. Remove the exhaust manifold; then remove the thermostat housing.

Cleaning and Inspecting Cylinder Head/Valves

1. Thoroughly clean the cylinder head in a non-caustic solvent; then dry with compressed air.

WARNING

Always wear safety glasses when working with compressed air.

2. Using a high-quality straight edge and feeler gauges, check the head for warpage; then holding the straight edge against the head, measure any warpage with the feeler gauge. Check corner-to-corner, side-to-side, and end-to-end.

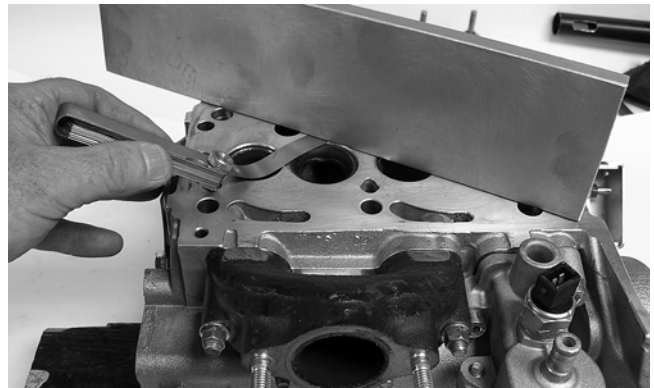

DE302

■NOTE: If cylinder head warpage is present, the cylinder head must be planed by a qualified machine shop. Pre-combustion chambers must be removed to plane the head.

3. Inspect the valve springs for surface cracks and fractures.
4. Using a calipers, measure the free-length of the valve springs. The measurement must be equal to or greater than minimum specifications.

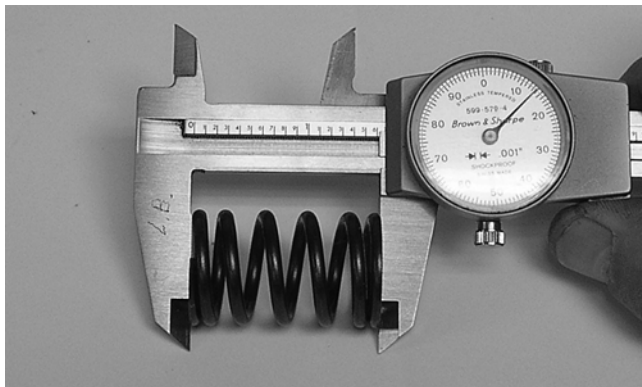

DE318

5. Check that the spring ends are parallel. A caliper may be used to check parallelism of spring ends.

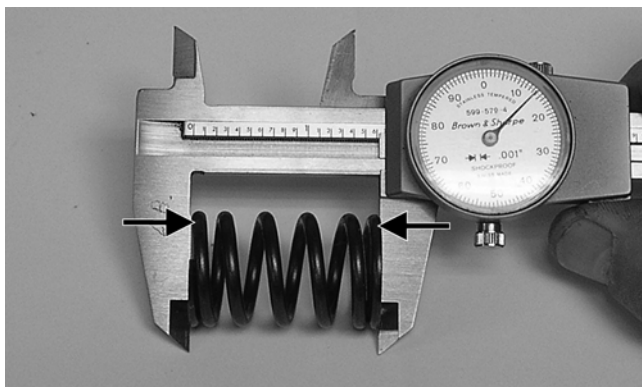

DE318A

6. Clean valve faces, valve seats, and valve stems. DO NOT use a wire brush on valve stems.
7. Using a suitable calipers or outside micrometer, measure the valve stem. If valve stem measures less than minimum specifications, the valve must be replaced.

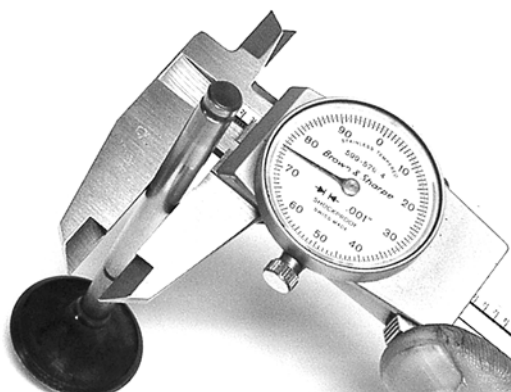

DE319

8. Measure the valve guide inside diameter using a suitable micrometer or bore gauge. If measurement is greater than specified, the valve guide must be replaced.
9. Check the valve seats for evidence of discoloration, cracks, or loose fit in cylinder head as well as clean, even contact area. Replace any valve seats that show evidence of excessive wear or damage.
10. Check the cylinder head for cracks, loose rocker arm studs, or loose injector hold-down studs. If cylinder head is cracked, it must be replaced.

Servicing Valves/Valve Guides/Valve Seats

If valves, valve guides, or valve seats require servicing or replacement, Arctic Cat recommends that the components be taken to a qualified machine shop for servicing.

CAUTION

If valves are discolored or pitted or if the seating surface is worn, the valve must be replaced. Do not attempt to grind the valves or severe engine damage may occur.

Assembling Valves

1. Thoroughly clean all valve components in parts-cleaning solvent; then dry with compressed air.

WARNING

Always wear safety glasses when working with compressed air.

2. Place new valve seals in clean engine oil and soak for five minutes; then using a suitable installation tool, install the seals on the valve guides.

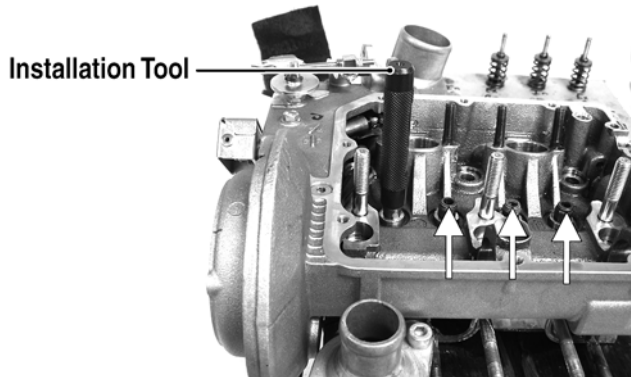

DE320A

CAUTION

Do not use a hammer to drive seals in place. Use only hand pressure or seal damage will occur.

3. Apply clean engine oil to valve stems and valve guides; then install the valves into the same port they were removed from.

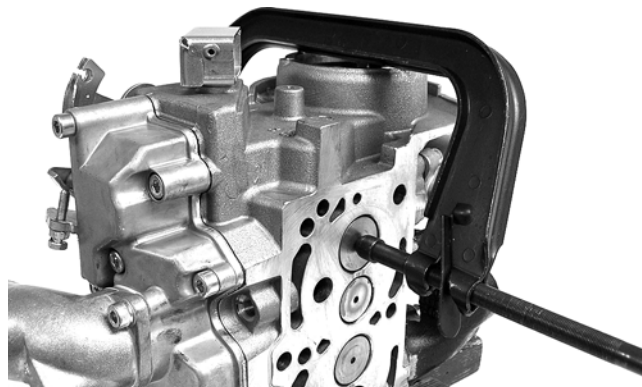

DE300

4. Place spring seat, valve spring, and spring cap into position; then using a suitable valve spring compressor, compress the spring and install the valve keepers onto the valve stem.

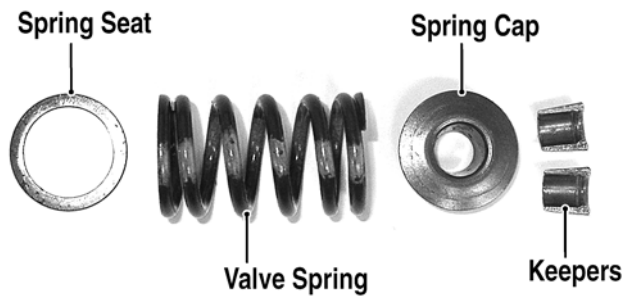

DE325A

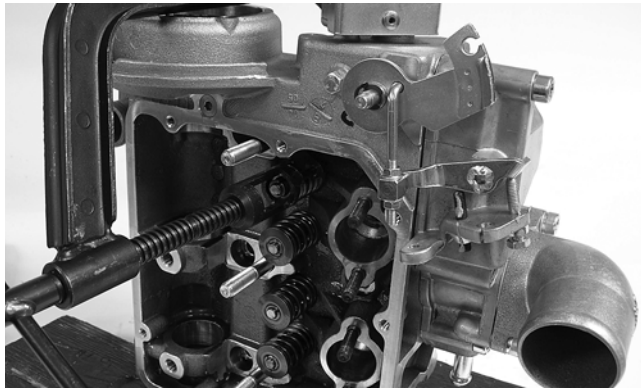

DE301

5. Slowly release the valve spring compressor while making sure the valve keepers engage the groove in the valve stem.

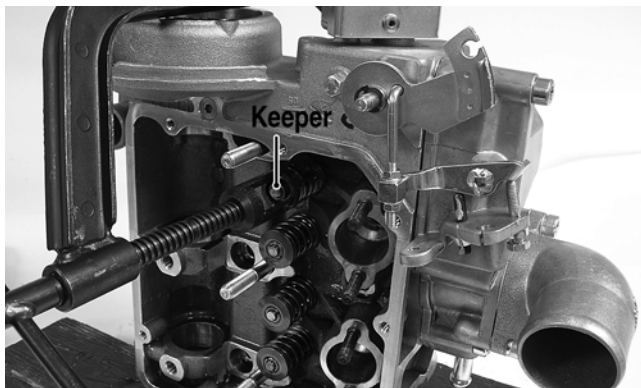

DE301A

Assembling Pre-Combustion Chambers/Glow Plugs

1. Carefully clean all carbon and cleaning residue from the sealing surfaces of the pre-combustion chambers/cylinder head being careful not to nick or scratch the cylinder head.

■NOTE: Non-caustic solvents may be used to assist in carbon removal. Dry with compressed air.

⚠ WARNING

Always wear safety glasses when working with compressed air.

2. Making sure any spacers/shims are correctly installed, place the pre-combustion chamber into the cylinder head with the glow plug opening directed toward the glow plug bore.

■NOTE: To simplify installation/orientation of the pre-combustion chamber, install the chamber on the removal tool; then place into the head. Remove the tool after completing step 3.

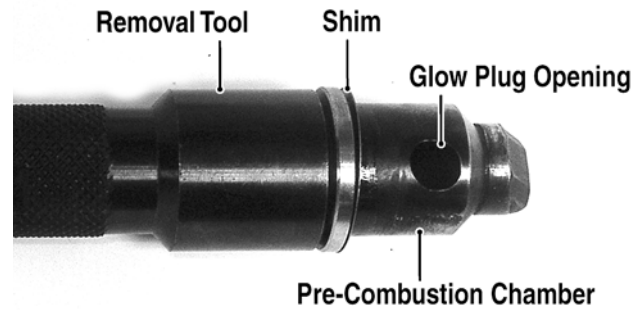

DE326A

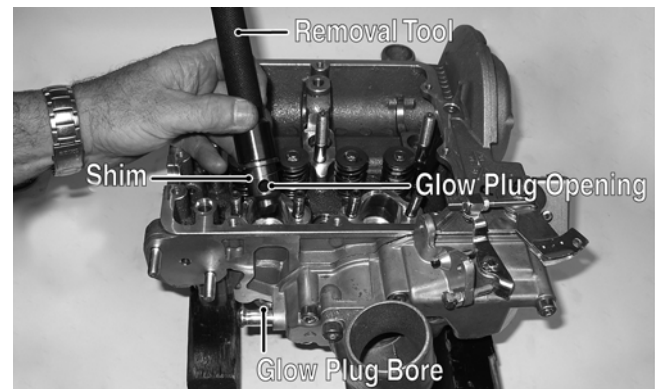

DE321A

3. Insert the Pre-Combustion Chamber Index Tool into the glow plug bore while slightly shifting the chamber until the alignment tool properly engages the opening in the chamber; then completely thread the tool in and tighten securely.

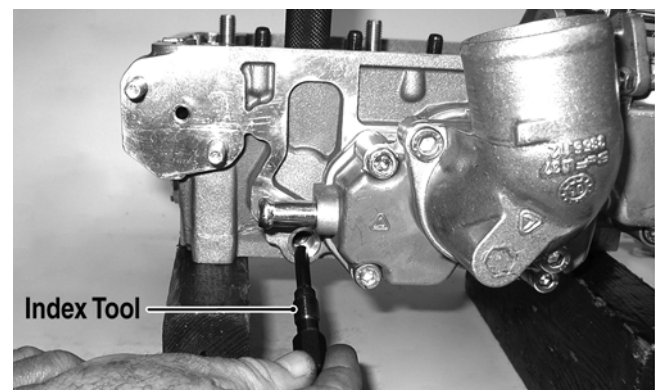

DE322A

4. If the removal tool was utilized, remove it from the chamber. Install the pre-combustion chamber ring nut and using the Pre-Combustion Chamber Ring Nut Tool, tighten the ring nut to an initial torque of 72 ft-lb; then to a final torque of 130 ft-lb.

Pre-Combustion Chamber Ring Nut

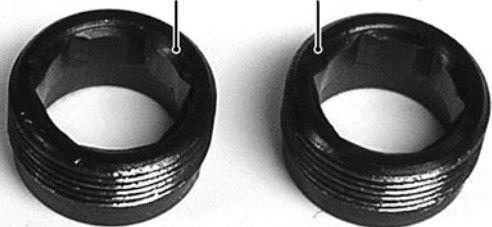

DE311A

5. Remove the Pre-Combustion Chamber Index Tool and repeat steps 2-4 for the second pre-combustion chamber; then install the glow plugs and tighten to 18 ft-lb.
6. Install the unit injectors (see Fuel/Lubrication/Cooling).
7. Install the governor linkage (see Speed Governor in this sub-section).
8. Install the camshaft (see Camshaft/Rocker Arms in this sub-section). At this point, the cylinder head is ready for installation on the engine block.

Installing

1. Prior to installing the cylinder head, a head gasket of the correct thickness must be selected in order to maintain adequate piston to cylinder head clearance. To select the correct cylinder head gasket, use the following procedure.
 - A. Rotate the crankshaft until one of the pistons is at top-dead-center (TDC) as indicated by a dial indicator.



DE330

- B. Using a depth micrometer, measure and record piston protrusion above the cylinder deck plane.

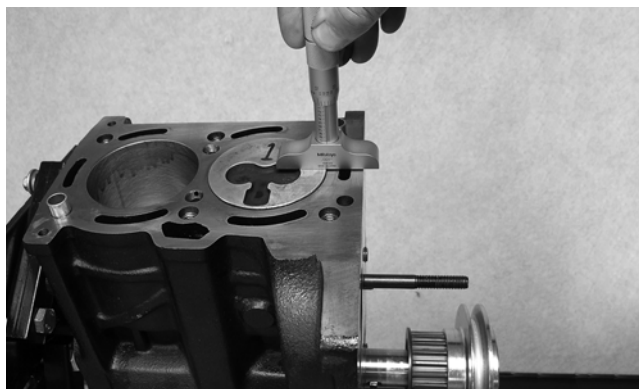

DE386

- C. Use steps A and B to measure and record piston protrusion on the other piston.
 - D. Use the piston with the highest protrusion to select the appropriate gasket from the following chart.

Piston Protrusion	Gasket Thickness	Hole Number
0.82-0.91 mm (0.032-0.036 in.)	1.56-1.64 mm (0.061-0.065 in.)	1
0.92-1.01 mm (0.036-0.040 in.)	1.66-1.74 mm (0.065-0.069 in.)	2
1.02-1.10 mm (0.040-0.043 in.)	1.76-1.84 mm (0.069-0.072 in.)	3

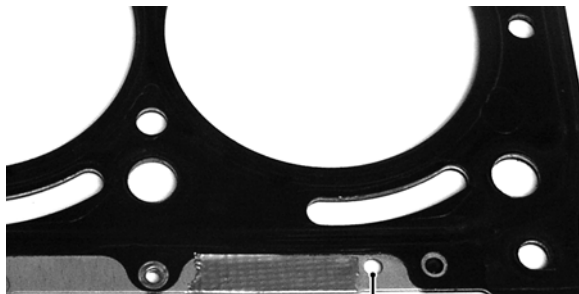

1.56-1.64 mm
(0.061-0.065 in.)

DE342A

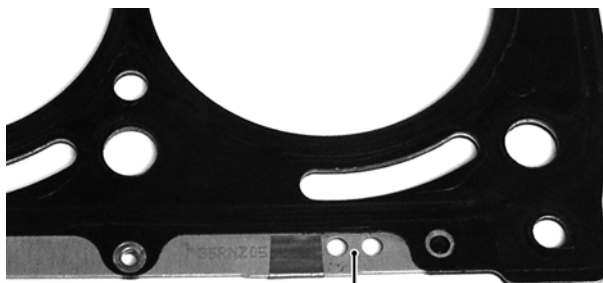

1.66-1.74 mm
(0.065-0.069 in.)

DE343A

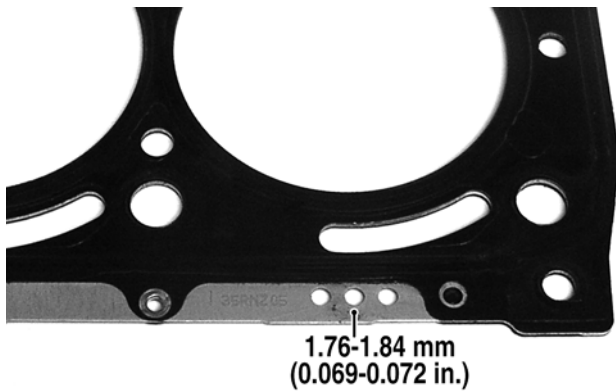

DE341A

2. Make sure the cylinder deck surface is clean and free of all oil, grease, varnish, or coolant.

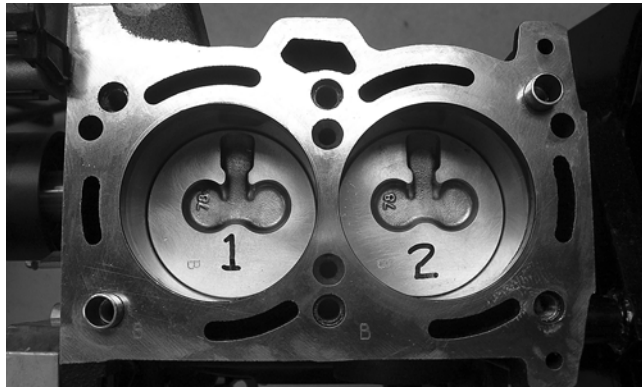

DE578

3. Remove all traces of fluid from the cylinder head bolt bores; then using an appropriate tap, clean the threads.

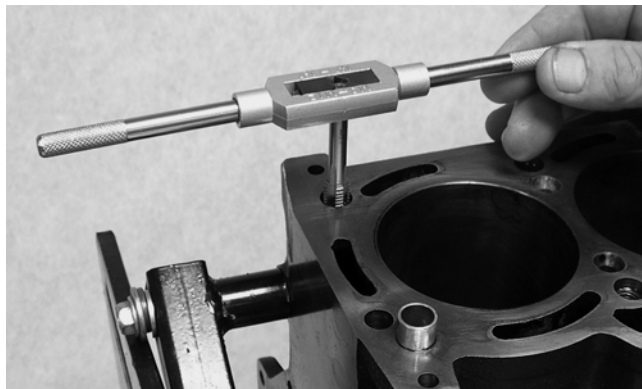

DE349

CAUTION

Failure to remove oil or coolant from bolt bores may result in hydraulic lock when installing head bolts. This will cause severe engine block damage.

4. Place the cylinder head gasket onto the cylinder deck aligning the gasket on the alignment pins; then carefully install the cylinder head onto the engine block aligning the head to the index dowels.

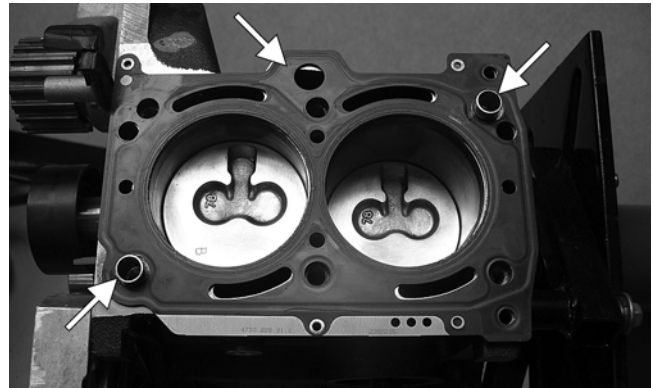

DE577A

5. Clean the threads of the cylinder head bolts on a wire wheel; then measure the length of the bolt. Bolt length must not exceed 91 mm.
6. Apply clean engine oil to the threads of the cylinder head bolts, washers, the bolt heads, and the thrust areas; then install and hand tighten.
7. Tighten the head bolts to 35 ft-lb in 7 ft-lb increments using the pattern shown.

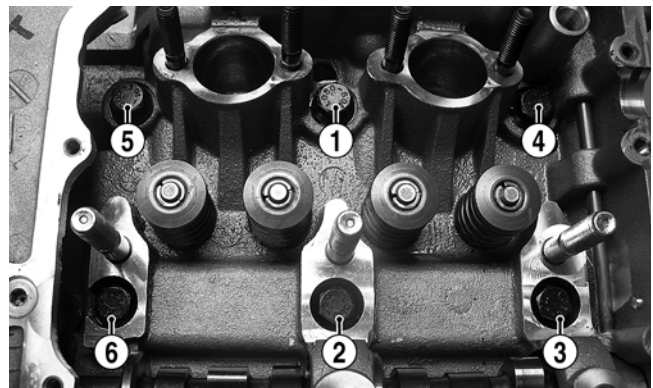

DE575B

8. In the same pattern, tighten each cylinder head bolt 90°; then tighten an additional 90° using the same pattern.

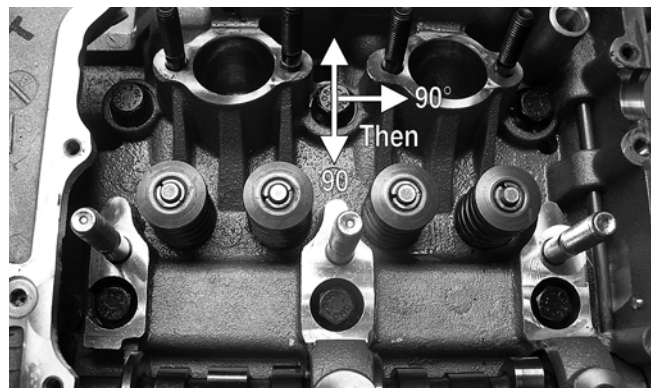

DE575C

CAUTION

Head bolts must be tightened in the proper sequence and in steps or engine damage may occur.

9. Install the rocker arms (see Camshaft/Rocker Arms in this sub-section).
10. Install the unit injectors (see Top-Side Components in this section).

11. Adjust the valves (see Top-Side Components in this section).
12. Check and adjust static injector timing (see Top-Side Components in this section).
13. Install the engine and transmission (see Installing Engine/Transmission in this section).

Left-Side Components

■**NOTE:** For efficiency, it is preferable to remove and disassemble only those components which need to be addressed and to service only those components. The technician should use discretion and sound judgment.

AT THIS POINT

To service any one specific component, only limited disassembly of components may be necessary. Note the AT THIS POINT information in each sub-section.

■**NOTE:** The engine/transmission does not have to be removed from the frame for this procedure.

TIMING BELT

Removing

1. Remove the front rack; then remove the front body panel (see Steering/Frame).
2. Remove the negative battery cable from the battery.
3. Remove the shift linkage from the shift arm and swing the linkage forward. Account for an E-clip, bushing, and washer.
4. Loosen the alternator mounting cap screws and remove the alternator belt.
5. Remove four cap screws securing the crankshaft pulley to the timing belt drive pulley; then install a suitable holding fixture and remove the center cap screw (left-hand threads).

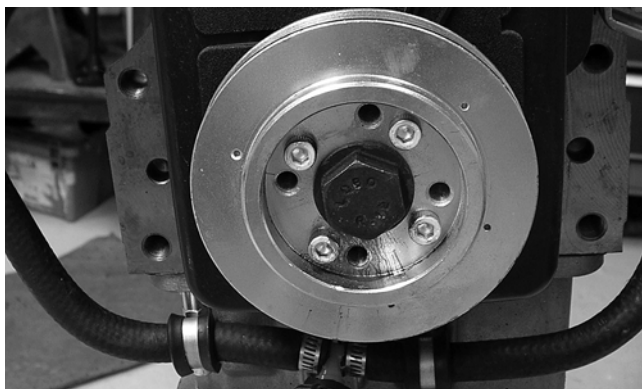

DE224



DE211A

6. Remove the holding fixture; then remove the crankshaft pulley.

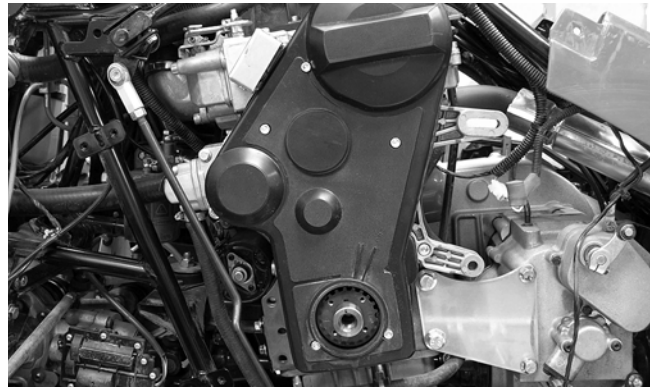

DE214

7. Remove the timing belt cover noting the position of the short cap screw.

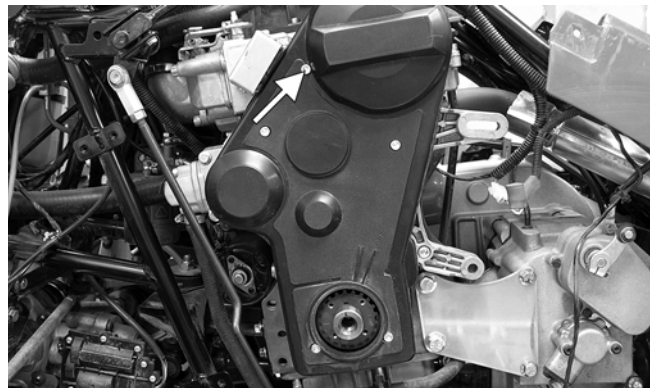

DE214A

8. Rotate the engine in the direction of rotation (clockwise facing the timing belt) until the reference mark (A) on the camshaft pulley aligns with the reference mark (B) on the cylinder head.

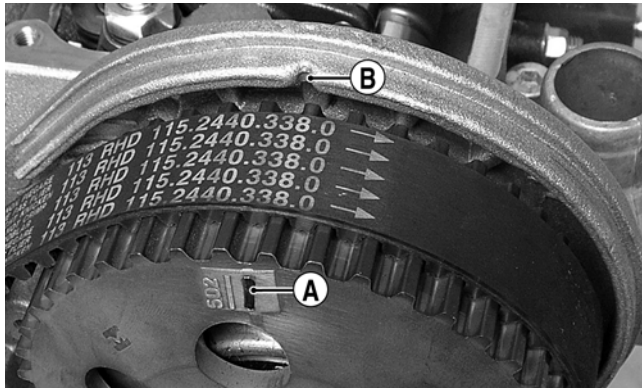

DE269A



DE273

9. Check that the reference mark (C) on the timing belt drive pulley aligns with the reference mark (D) on the oil pump housing.

2. Inspect the drive and driven pulleys for wear, burrs, or dirt build-up between cogs. Clean and remove burrs as required.

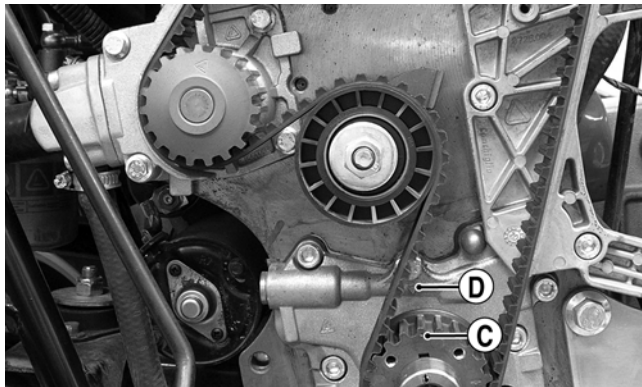

DE230A

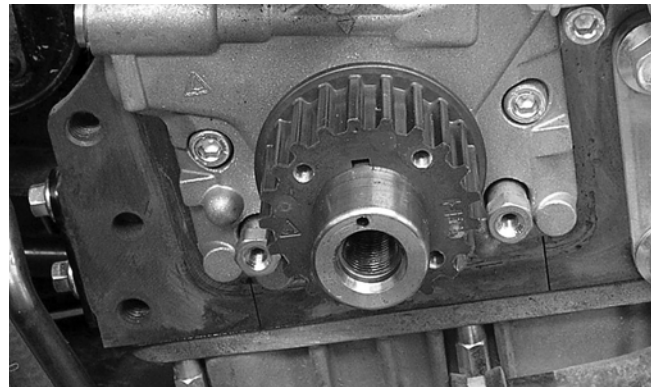

DE232

10. Loosen the retaining nut on the timing belt idler pulley; then loosen the belt and remove from the engine.

3. Inspect the timing belt cover for cracks, seal damage, or signs of oil leakage. If oil is present, locate and repair any leaks. Thoroughly clean all oil from the timing belt cover and pulleys.

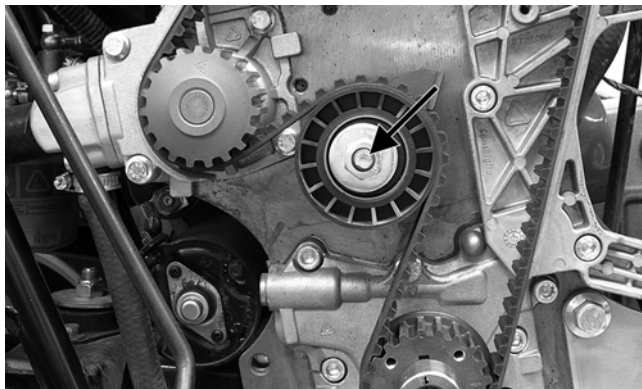

DE230B

Installing

1. Check that the reference mark (C) on the timing belt drive pulley is aligned with the reference mark (D) on the oil pump housing and the reference mark (A) on the camshaft drive pulley is aligned with the reference mark (B) on the cylinder head.

■ **NOTE:** If the camshaft or crankshaft has been rotated, use the following procedure to safely realign the reference marks.

A. Carefully rotate the crankshaft until the reference mark (C) on the timing belt drive pulley is approximately 90° from the reference mark (D) on the oil pump housing.

CAUTION

Do not rotate the camshaft or valve damage could occur.

Inspecting

1. Check the timing belt for missing cogs, cracks, or bare cords showing. Replace if any of the conditions are present.

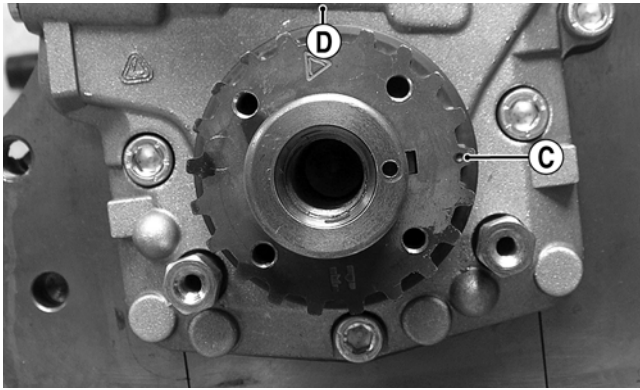

DE275B

B. Rotate the camshaft to align the reference marks (A and B); then rotate the crankshaft to align reference marks (C and D).

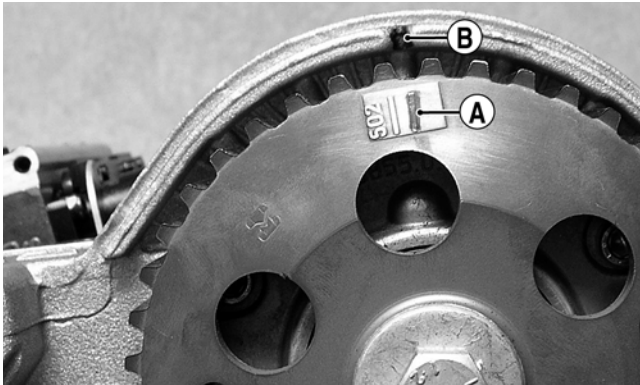

DE272A

2. Install the timing belt keeping tension on the belt between the drive pulley and the camshaft pulley. Make sure the arrows are orientated in the direction of engine rotation.

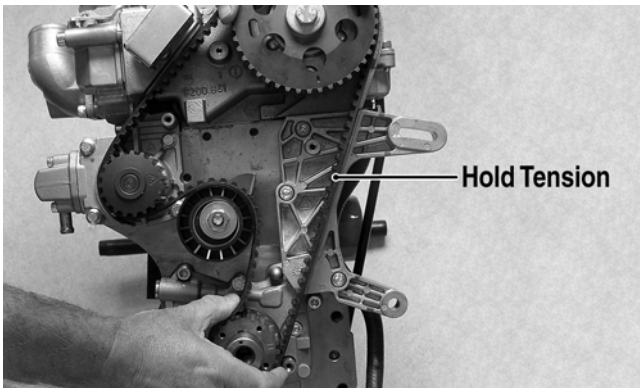

DE270A

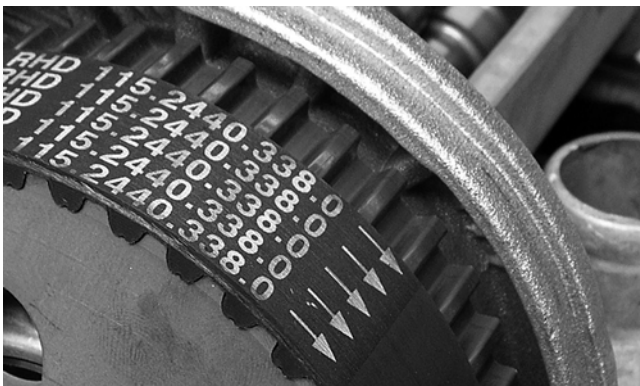

DE225

3. Install the Timing Belt Tensioning Tool on the timing belt tensioner tab; then using a suitable torque wrench, position the handle 90° to the tensioner tab and apply 14.5 ft-lb of torque. Tighten the timing belt idler nut securely.



DE234A



DE222A

4. Rotate the engine in the direction of rotation (clockwise facing the timing belt) three full revolutions; then loosen the idler nut and repeat step 3.

5. After repeating step 4 two times, tighten the timing belt idler nut to 29 ft-lb.

6. Install the timing belt cover and secure with the existing hardware; then install the crankshaft pulley making sure the alignment pin is correctly located.

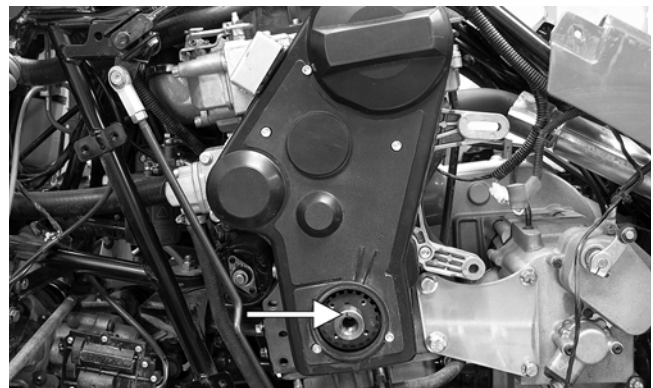

DE214B

7. Install the four cap screws and finger tighten; then install a suitable holding fixture.

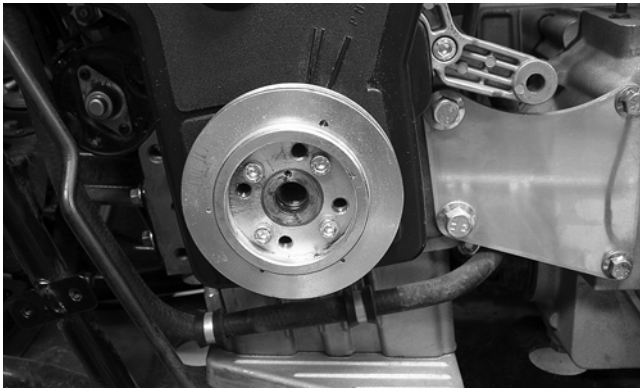

DE213

- Apply blue Loctite #243 to the crankshaft pulley retaining cap screw and tighten to 260 ft-lb.



DE212

- Tighten the four cap screws from step 7 to 9 ft-lb.
- Install the alternator belt and tighten so that 10 kg (22 lb) of force at the belt midpoint results in 10-15 mm (0.4-0.6 in.) of deflection; then tighten the mounting cap screws securely.

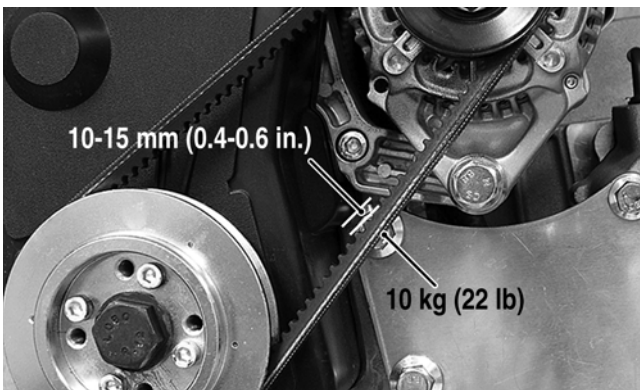

DE103B

- Connect the shift linkage to the shift arm and secure with the E-clip.
- Install the front body panel; then install the front rack. Tighten the existing hardware securely.

WATER PUMP

Removing

- Remove the timing belt (see Left-Side Components in this section).
- Drain the coolant (see Fuel/Lubrication/Cooling).

- Remove the lower radiator hose and the coolant bypass hose from the water pump; then remove four cap screws securing the water pump and remove the water pump.
- Thoroughly clean all gasket material from the engine block and water pump.

Servicing

■NOTE: The water pump is not a serviceable component. If it is defective, it must be replaced as an assembly.

Installing

- Make sure all mating surfaces are free of any gasket material, sealant, or residue.
- Using a new gasket, install the water pump onto the engine and secure with the four cap screws. Tighten to 22 ft-lb.

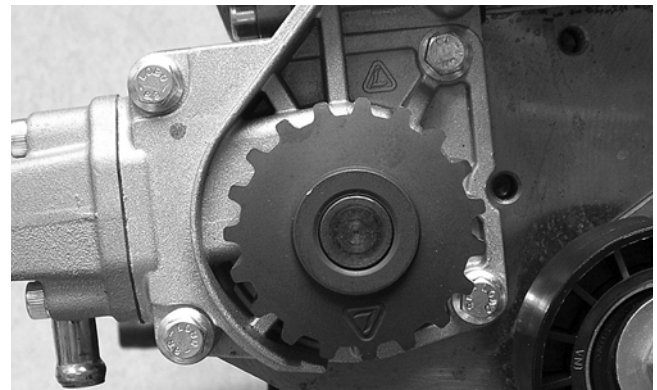

DE267

- Install the timing belt (see Left-Side Components in this section).
- Fill the cooling system with coolant (see Fuel/Lubrication/Cooling).
- Check for coolant leaks and proper coolant level.

OIL PUMP/CRANKSHAFT SEAL

Removing

- Remove the timing belt (see Left-Side Components in this section).
- Remove the timing belt drive pulley. Account for a key.



DE226

- Remove the screws securing the oil pump to the engine block; then tap lightly on the oil pump with a plastic mallet to loosen the gasket and remove the oil pump assembly from the crankshaft.

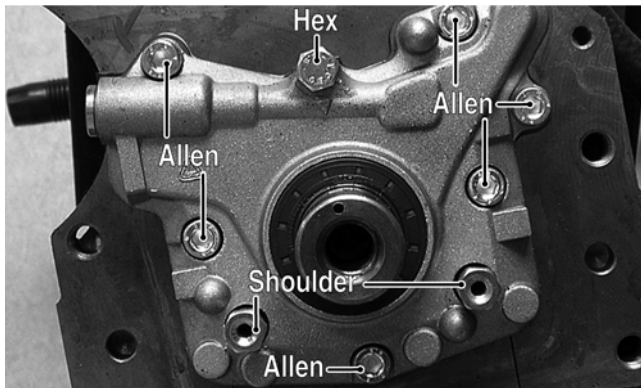

DE227A

■NOTE: The keyway in the crankshaft MUST be in the 12 o'clock position before attempting to remove the oil pump.

AT THIS POINT

If the oil pump is being removed for servicing, proceed to Servicing in this sub-section. If the left-side crankshaft seal is being replaced, proceed to step 4.

- Using an appropriate seal removal tool, remove the crankshaft oil seal from the oil pump housing being careful not to mar or scratch the seal bore.

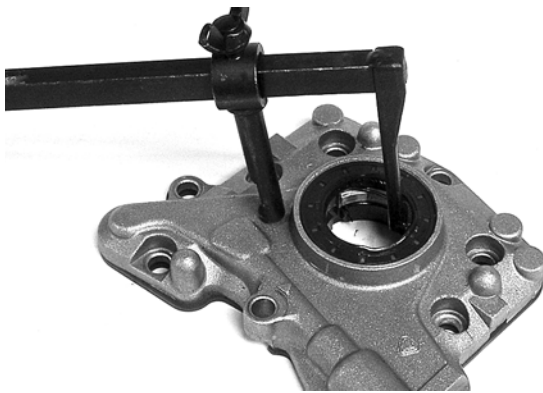

DE238

- Thoroughly clean the seal bore making sure it is free of all oil and sealant and free of any nicks or burrs.
- Soak a new oil seal in clean engine oil for approximately 30 minutes; then using an appropriate driver, drive the seal into the oil pump housing until flush with the outer seal bore.



DE237

■NOTE: If there is a groove worn in the crankshaft where the seal contacts, press the seal into the bore an additional 2 mm (0.080 in.).

Servicing

■NOTE: The oil pump is a non-serviceable component and must be replaced as an assembly. Only the crankshaft seal is serviceable. When replacing the oil pump, install a new oil seal (proceed to Installing).

Installing

- Clean all gasket material from the surface of the engine block.
- Make sure the oil pump drive key in the crankshaft is in the 3 o'clock position; then locate the oil pump inner rotor keyway in the 3 o'clock position as viewed from the crankshaft seal.

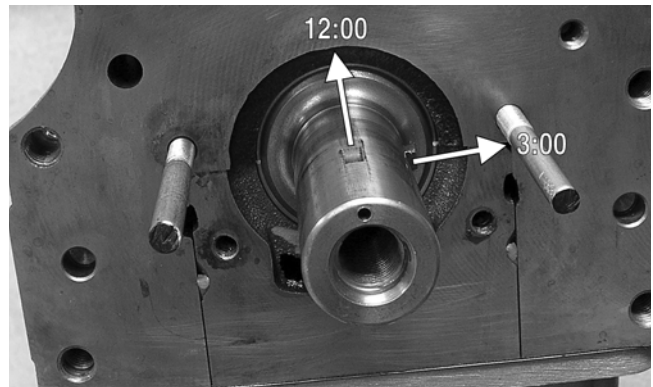

DE265A

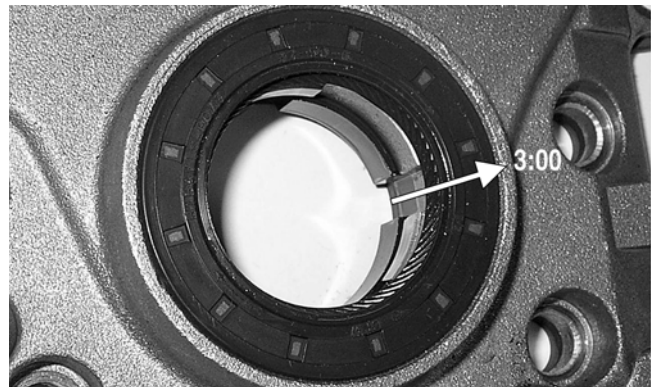

DE237A

- Install two alignment bolts in the engine block; then install a new oil pump gasket into position on the engine block.

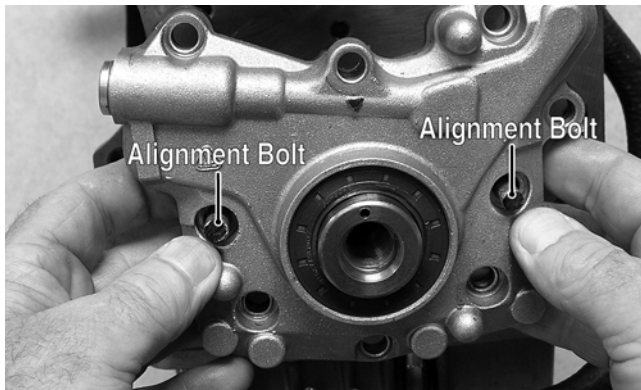

DE266A

- Lubricate the crankshaft and crankshaft seal with a liberal amount of engine oil; then install the oil pump onto the crankshaft being careful not to damage the oil seal.

NOTE: It may be necessary to rock the oil pump slightly from side-to-side to engage the keyway completely onto the key.

CAUTION

Never attempt to force the oil pump into position by hammering or drawing in with the cap screws. The inner rotor will be broken and severe engine damage will occur.

- Completely seat the oil pump against the engine block; then secure with the existing hardware and tighten to 22 ft-lb. Note the correct cap screw locations.

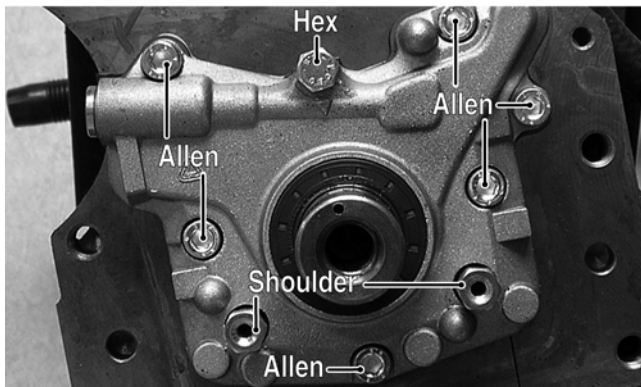

DE227A

- Install the alternator bracket and secure with the three cap screws. Tighten securely.
- Install the key in the crankshaft; then install the timing belt drive pulley.
- Install the timing belt (see Left-Side Components in this section).

ALTERNATOR/REGULATOR

Removing

- Remove the negative battery cable from the battery; then remove the seat and left-side engine cover.
- Disconnect the battery (B+) wire from the alternator; then disconnect the voltage regulator control plug-in.

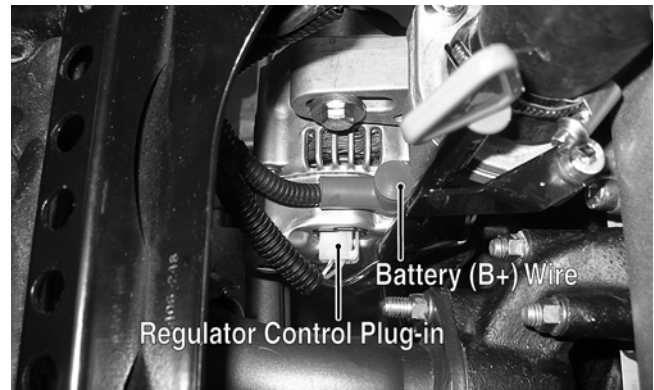

DE519B

- Loosen the alternator adjuster cap screw (A) and the pivot bolt (B); then remove the alternator drive belt.

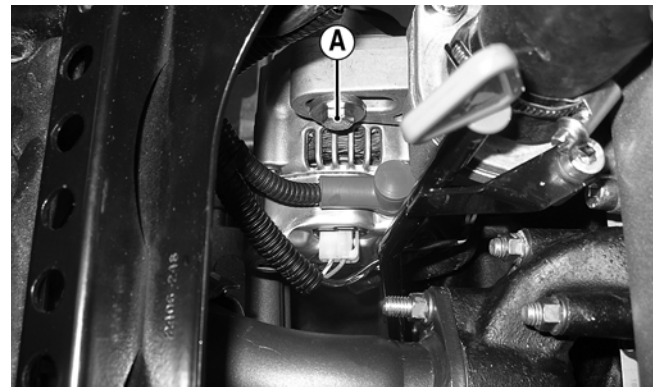

DE519C

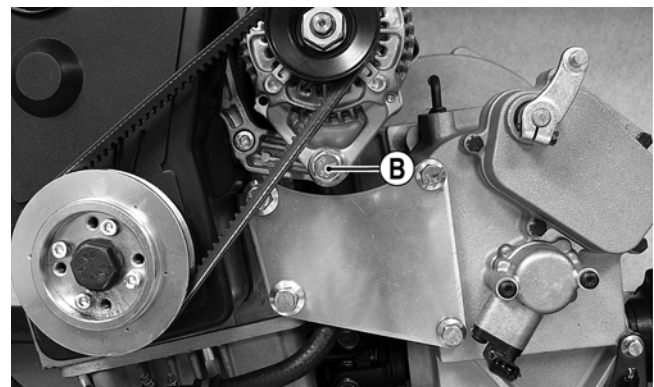

DE103C

- Remove the adjuster cap screw and pivot bolt and remove the alternator.

Servicing

NOTE: The alternator/regulator is not a serviceable part; therefore, it must be replaced as an assembly.

Installing

- Place the alternator/regulator into position on the engine; then secure with the existing hardware. Do not tighten at this time.
- Place the alternator drive belt into position; then using a suitable pry, tension the drive belt so that a 10 kg (22 lb) force applied at the midway point will result in a deflection of 10-15 mm (0.4-0.6 in.).

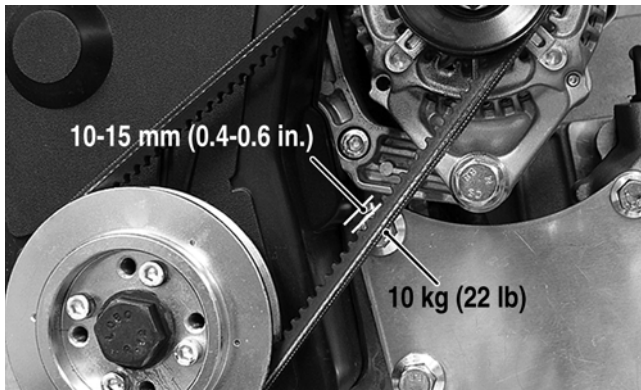

DE103B

3. Holding tension on the belt, tighten the adjuster cap screw securely; then remove the pry and tighten the pivot bolt securely.
4. Connect the battery (B+) wire and connect the regulator control plug-in; then connect the negative battery cable to the battery.
5. Install the-left side engine cover and seat making sure the seat latches securely.

Right-Side Components

■NOTE: For efficiency, it is preferable to remove and disassemble only those components which need to be addressed and to service only those components. The technician should use discretion and sound judgment.

👉 AT THIS POINT

To service any one specific component, only limited disassembly of components may be necessary. Note the AT THIS POINT information in each sub-section.

■NOTE: The engine/transmission does not have to be removed from the frame for this procedure.

👉 AT THIS POINT

If the technician's objective is to service/inspect the V-belt cover, driven pulley, or drive clutch, see Periodic Maintenance/Tune-Up.

FLYWHEEL/PTO/V-BELT HOUSING

Removing

1. Remove the transmission (see Removing Engine/Transmission - Transmission in this section).
2. Using Drive Clutch Removal Tool, remove the fixed drive face/clutch hub.

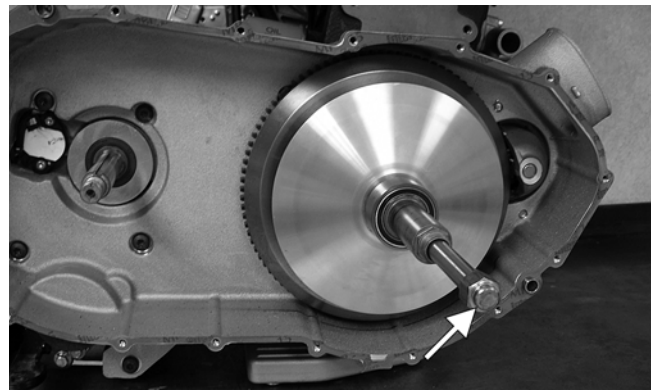

DE099A

3. Remove two cap screws securing the starter to the V-belt housing; then remove the starter.

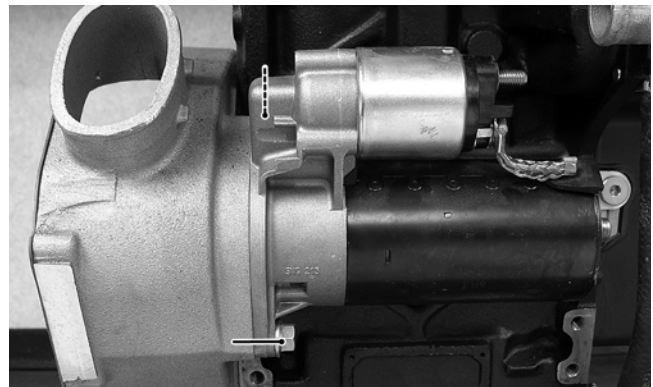

DE102A

4. Remove the PTO/flywheel; then remove four countersunk cap screws securing the V-belt housing to the engine block and remove the V-belt housing.

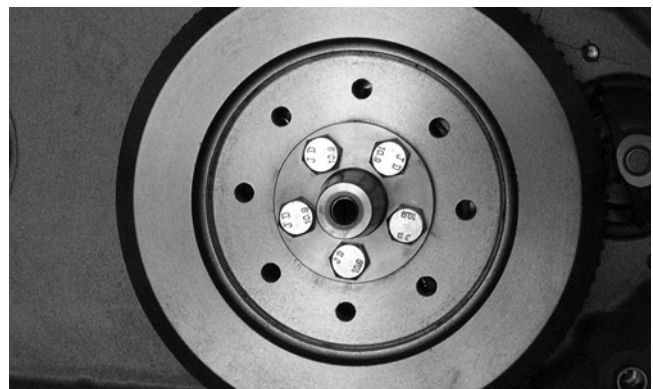

DE109

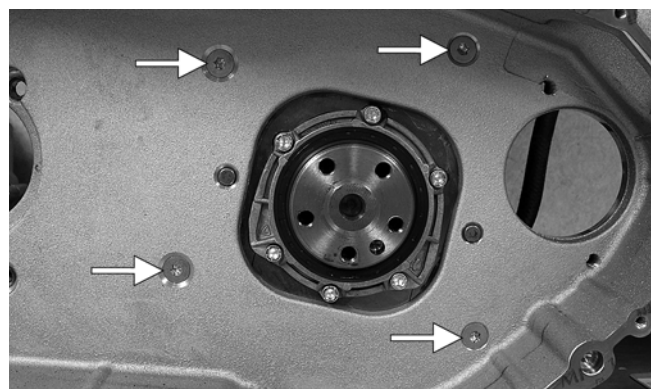

DE114A

Inspecting

1. Inspect the V-belt housing for cracks, elongated mounting hoses, or loose alignment pins.
2. Inspect the flywheel/ring gear assembly for worn or broken teeth, cracks, or elongated mounting holes.

Replacing Ring Gear

To replace the ring gear, use the following procedure.

1. Lay the flywheel/ring gear assembly on a flat surface with the PTO side up; then using a cold chisel and hammer, score the ring gear in several locations around the circumference.

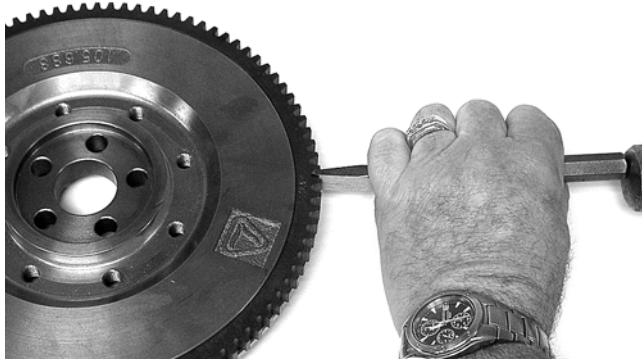

DE591

2. Turn the flywheel/ring gear assembly over and support on a suitable block so that the ring gear is free to be driven from the flywheel; then using a punch and hammer, tap the ring gear off the flywheel.

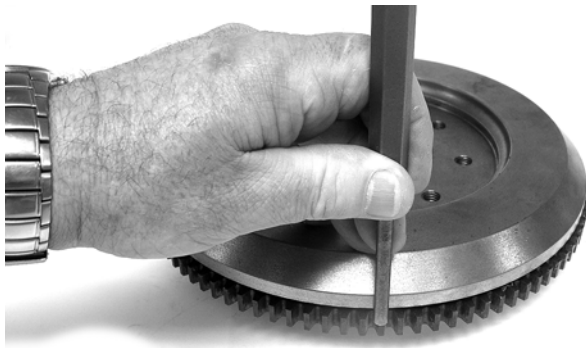

DE592

3. Lay the flywheel on a flat surface with the PTO side up; then place the new ring gear in an oven heated to 300° C (572° F) for 20 minutes.
4. Using suitable insulated gloves, place the heated ring gear onto the flywheel; then gently tap the gear down until firmly seated.



DE594

Installing

1. Using a new gasket, secure the V-belt housing to the engine block with the four countersunk cap screws tightened to 25 ft-lb; then install the flywheel/PTO shaft on the crankshaft and using the pattern shown, tighten the five cap screws to 40 ft-lb.

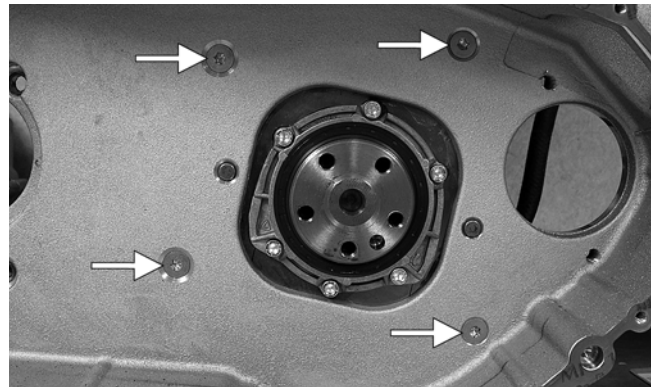

DE114A

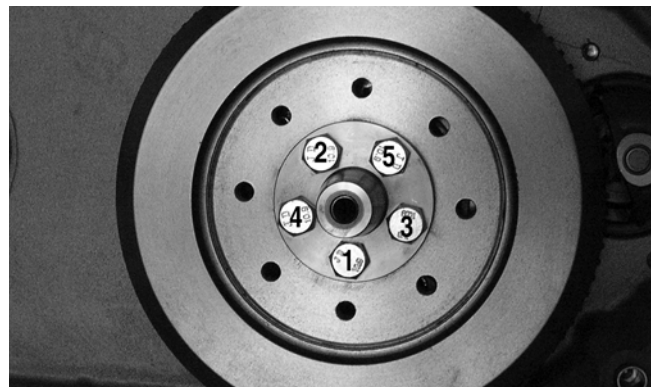

DE109A

2. Install the starter and tighten the cap screws to 35 ft-lb.

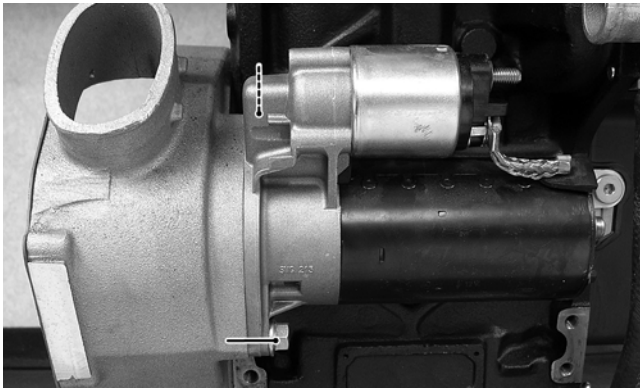

DE102A

TRANSMISSION

Disassembling Gear Case

1. Remove the gear position switch. Account for two contact pins and two springs.

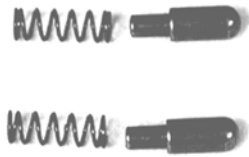

CD997

2. Remove the cap screws securing the secondary output shaft bearing housing; then tap the housing with a rubber mallet and remove. Account for two alignment pins.

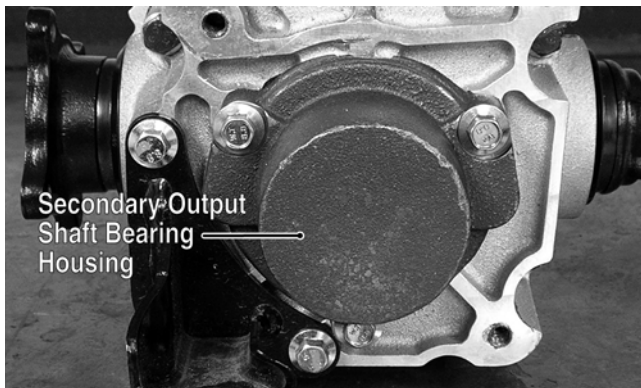

DE117A

3. Mark the shift shaft to align with a reference on the shift arm; then remove the shift arm.

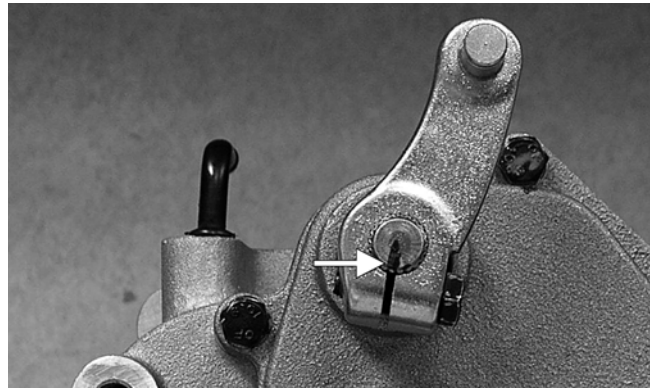

DE119A

4. Remove the shift shaft housing. Account for a gasket.
5. Remove the shift shaft, noting the match marks on the drive and driven gear plates. Account for a washer on each end.

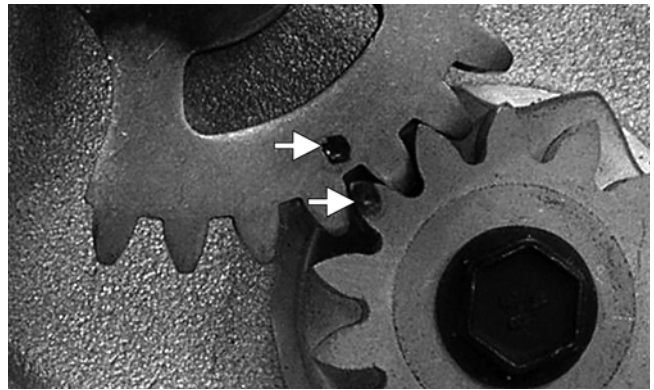

DE122A

6. Remove the nut securing the shift cam detent stopper/spring assembly; then remove the assembly and account for a spring and washer.

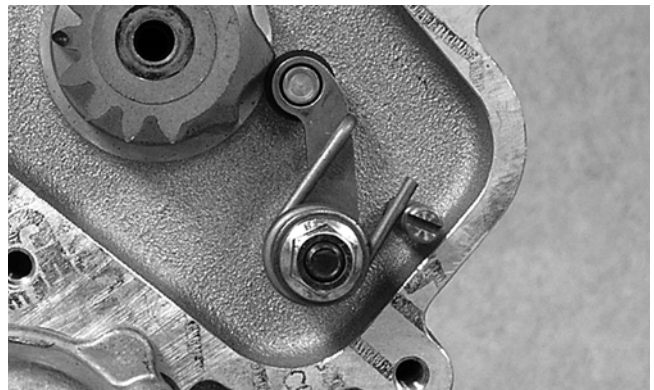

DE123

7. Remove the speed sensor housing; then remove the snap ring securing the rotor and remove the rotor. Account for two alignment pins, a gasket, and two snap rings.

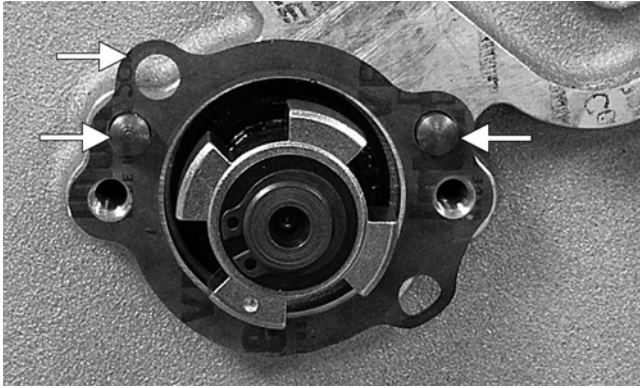

DE126A

- From the right side, remove the cap screws securing the transmission halves together; then lay the transmission on a suitable bench with the right side down.

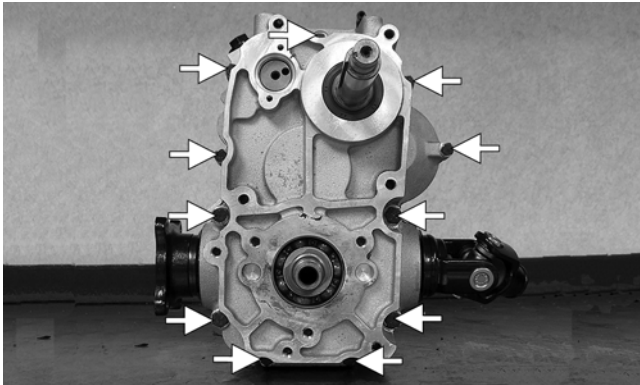

DE130A

- Using a rubber mallet, lightly tap the left-side gear case away from the right-side gear case leaving all components in the right side. Account for any washers that may stick to the left-side gear case and return to the proper shafts.



DE132

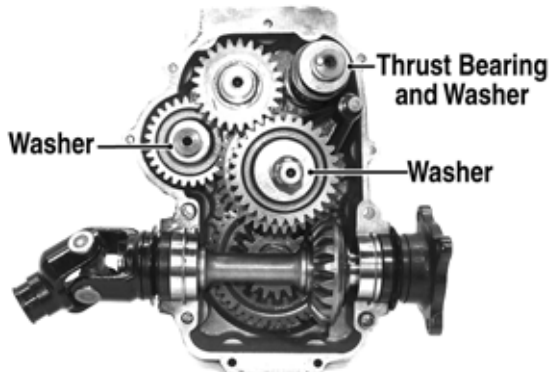

DE663A

■NOTE: For steps 10-15, refer to illustration DE663B.

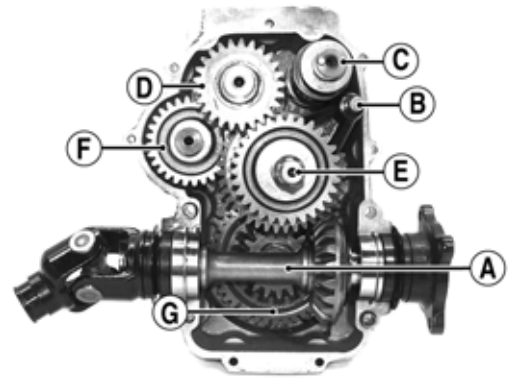

DE663B

- Remove the output driveshaft assembly (A). Account for the bearing alignment C-ring in the bearing boss next to the output driven bevel gear.

■NOTE: Note the location of the bearing alignment pin on the front output driveshaft bearing.

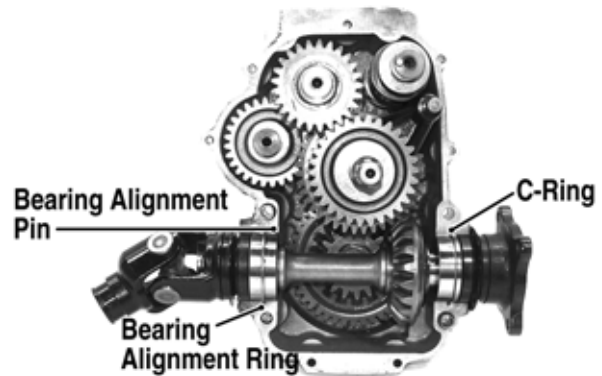

DE663D

- Remove the shift fork shaft (B); then remove the high/low shift fork.
- Remove the shift shaft (C) and account for a spacer and washer.



DE677A

- Remove the low/reverse shift fork; then remove the input driveshaft (D).

■NOTE: The shift forks are identical; therefore, they may be used in either location. However, it is advisable to return mating parts to their original positions during assembling.

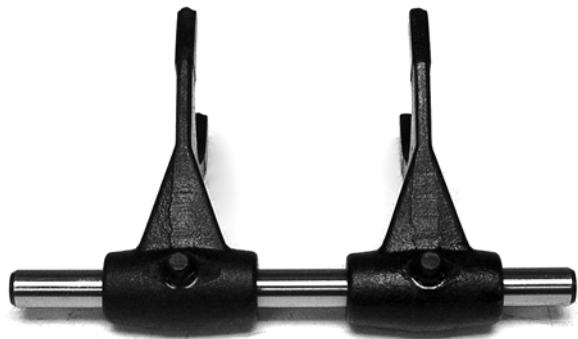

DE139

14. Remove the countershaft assembly (E). Account for a thrust washer on each end noting the different sizes.



DE655A

17. Using an appropriate seal removal tool, remove any damaged seals from the transmission case.

18. Remove the snap ring securing the output drive bearing in the right-side case; then using appropriate bearing drivers, remove the appropriate bearings.



DE142A

15. Remove the reverse idler gear (F). Account for the axle, a bushing, and two thrust washers.



DE169

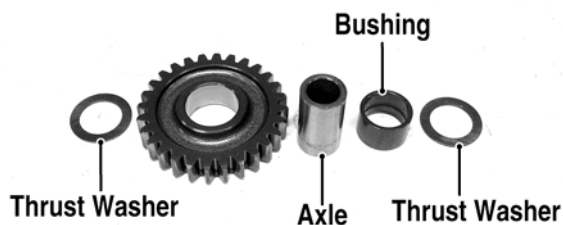

DE143A

■NOTE: The thrust washers on the reverse idler gear are identical.

AT THIS POINT
 If the drive bevel gear assembly (G), bearings, countershaft assembly (E), seals, or output driveshaft assembly (A) do not require servicing, no further disassembly is required (proceed to Inspecting).

16. Heat the retaining nut on the secondary output shaft; then holding the gear assembly securely, remove the retaining nut. Account for the shims.

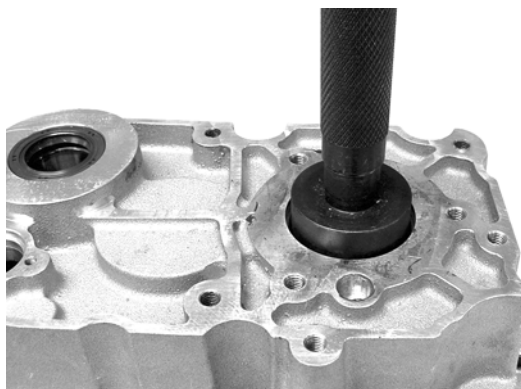

DE170

Disassembling Driveshaft/ Drive Bevel Assembly

■NOTE: Steps 1-18 of the preceding sub-section must precede this procedure.

19. Remove the retaining C-rings in the output yoke; then using an appropriate universal joint service tool, separate the front drive yoke and bearing universal joint from the rear yoke.



DE146

20. Remove the retaining nut from the front driveshaft and remove the front drive yoke. Account for a washer, seal, bearing, and shim.



DE147

21. Remove the retaining nut from the rear driveshaft and remove the rear drive output coupler. Account for a washer, bearing, and seal.



DE149

Disassembling Countershaft

■NOTE: Steps 1-21 of the preceding sub-sections must precede this procedure.

22. Remove the high driven gear; then remove the high/low shift dog. Account for a washer and the high driven gear bearing and bushing.

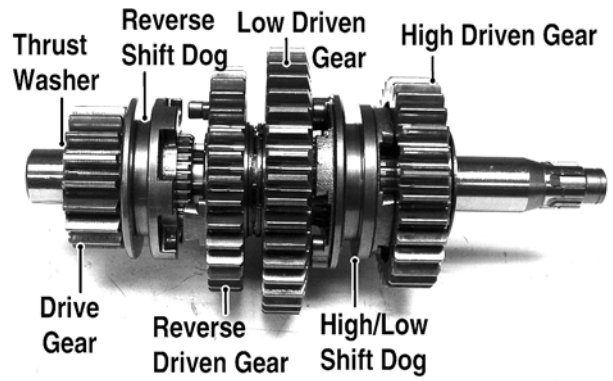

DE150A

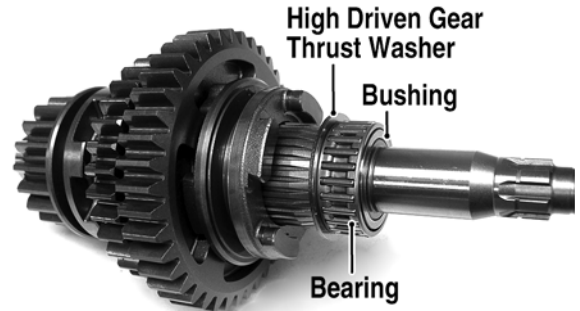

DE191A

23. Remove the thrust washer and countershaft drive gear from the opposite end of the countershaft.



DE150A

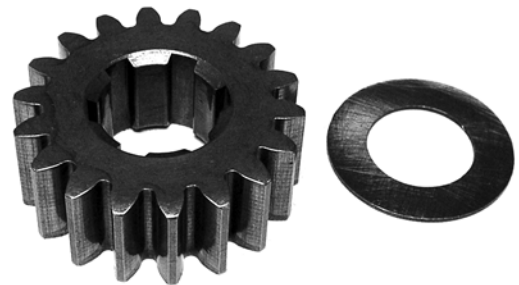

DE151

24. Remove the reverse dog retaining snap ring; then remove the reverse dog and reverse dog drive bushing.



DE152



DE184

27. Remove the low gear. Account for a washer and the low gear bearing and bushing.



DE153

25. Remove the snap ring securing the reverse gear; then remove the reverse gear. Account for a thrust washer and the reverse gear bearing and bushing.



DE155



DE154

Inspecting

1. Inspect all shafts for excessive wear, worn splines, bearing surface discoloration, or chipped gears.

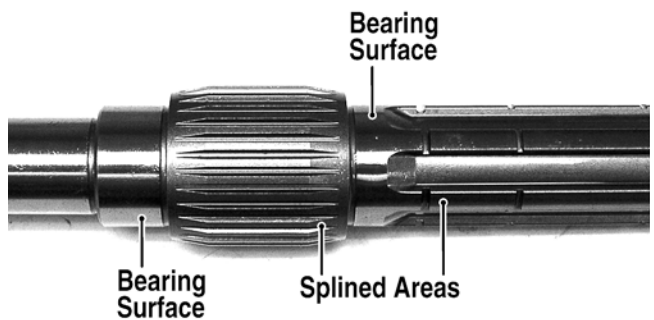

DE158A



DE155

26. Remove the low gear locking washer; then rotate and remove the splined low gear retainer.

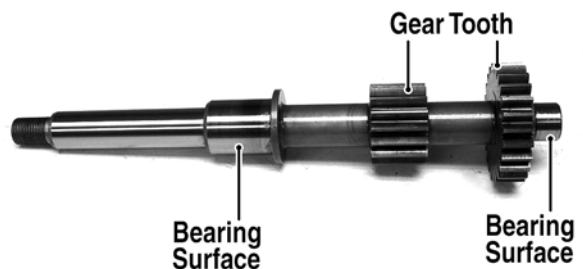

DE140A

2. Inspect all shift dogs for chips, rounded dogs, worn splines, or discoloration.

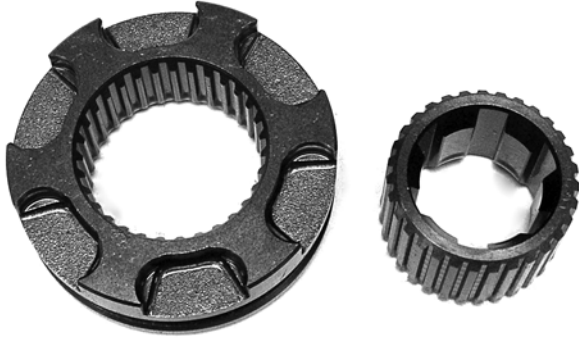

DE162



DE177

3. Inspect all idler gears, bushings, thrust washers, and shafts for abnormal wear, discoloration, chipping, or galling.



DE143

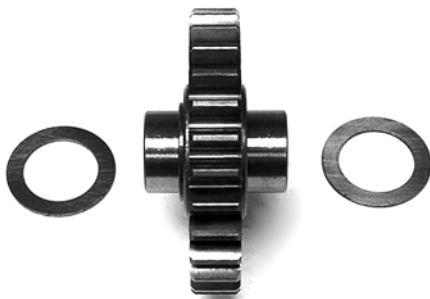

DE179

4. Inspect roller bearings for chipping, missing rollers, or discoloration.

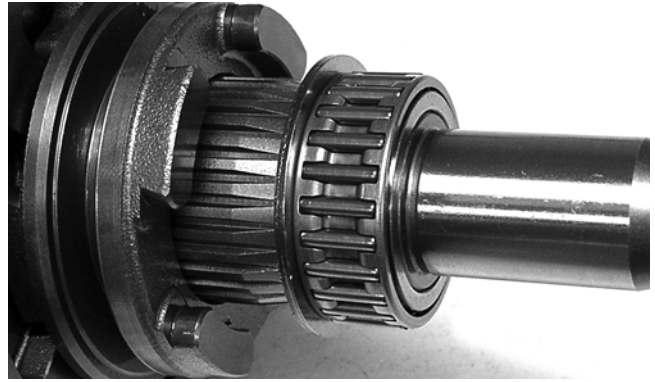

DE178



DE185

5. Inspect drive and driven bevel gears for proper tooth contact, chipping or discoloration of gear teeth, worn or chipped splines, and bearing smoothness.



DE657

6. Inspect sliding shift dogs for binding on splines, chipped or distorted splines, or discoloration.

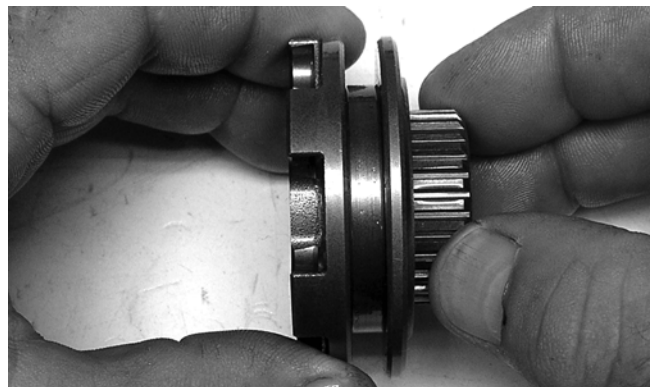

DE160

7. Inspect shift forks for excessive wear, galling of wear surfaces, or discoloration.

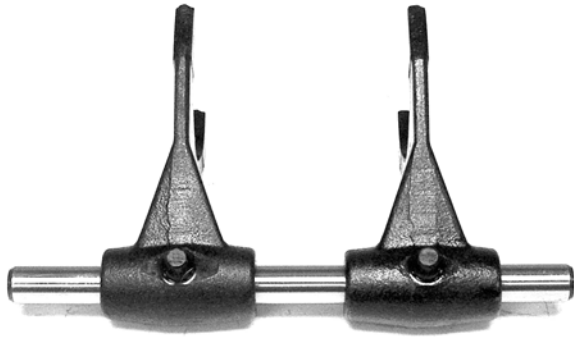

DE165

8. Inspect shift cam assembly for worn cam grooves or broken springs.

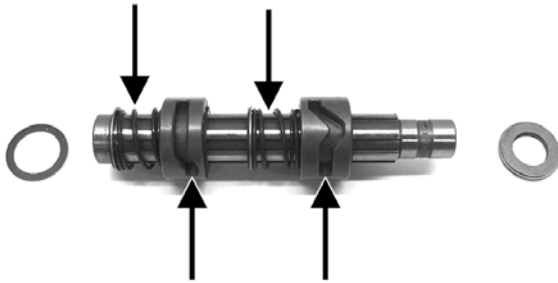

DE677C

9. Inspect transmission case halves for loose bearings, discolored bearing pockets, filings, or damaged threads.

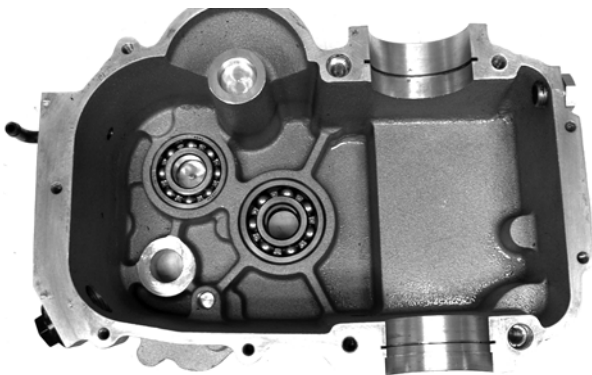

DE171

10. Inspect shift cam detent stopper and shift cam detent for worn rollers or broken spring.

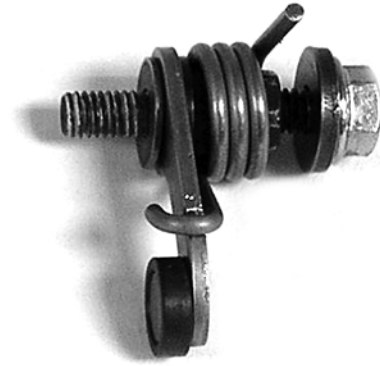

DE128

11. Inspect bearings for discoloration, flaking, or roughness and binding when turning.

12. Inspect and thoroughly clean all bearing pockets, thread bores, and plug openings to remove any metal filings or dirt accumulations.

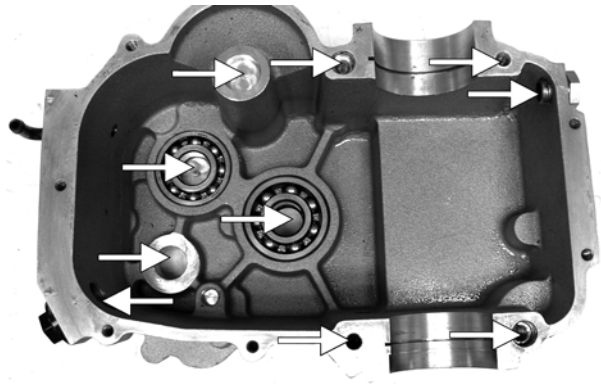

DE171A

13. Clean all parts to be used for assembling in parts-cleaning solvent; then dry with compressed air.

⚠ WARNING

Always wear eye protection when using compressed air.

Assembling Countershaft

1. Place the thrust washer on the splined end of the countershaft; then install the low driven gear bushing and bearing.

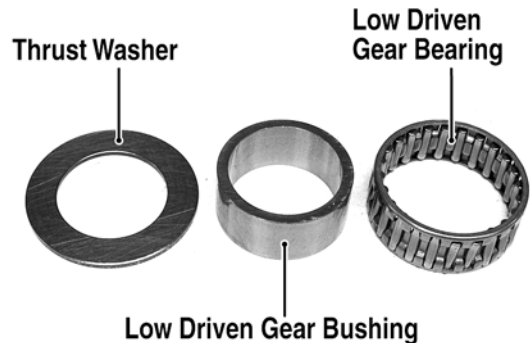

DE155A



DE158B

2. Install the low driven gear onto the bearing with the shift dog slots directed toward the fine-splined section of the countershaft; then secure with a splined washer and lock washer.

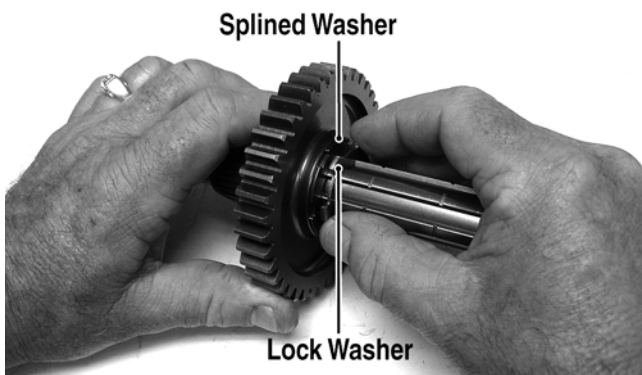

DE184

3. Place a splined thrust washer onto the countershaft; then install the reverse driven gear bushing and bearing.



DE185A

4. Install the reverse driven gear onto the bearing; then secure with a splined washer and snap ring.

■NOTE: Always install snap rings with the flat (sharp) side away from the washer.



DE186

5. Install the reverse shift dog and splined bushing onto the shaft; then secure with a snap ring.

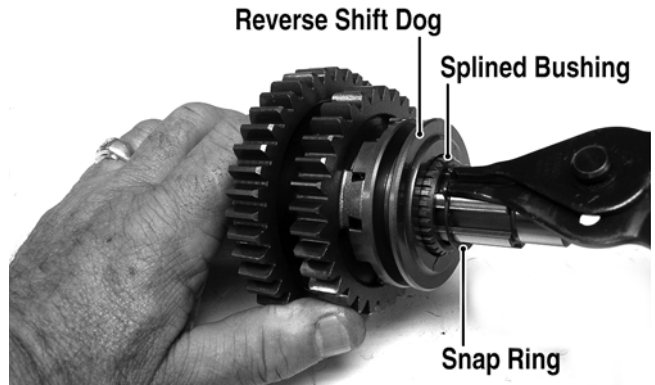

DE187A

6. Install the countershaft drive gear and thrust washer.

7. Install the high/low shift dog with the raised lugs directed toward the low driven gear.



DE189A

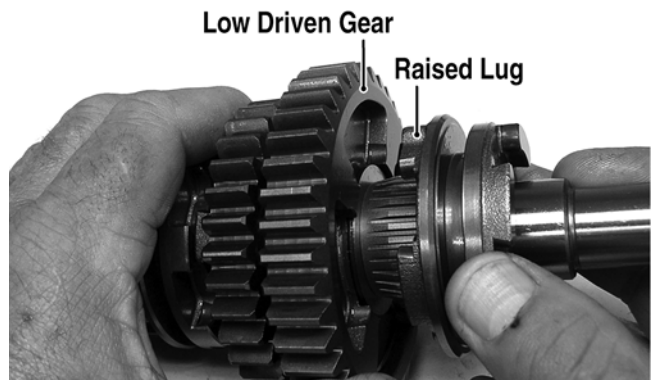

DE190A

8. Install the high driven gear thrust washer, bushing, and bearing; then install the high driven gear and thrust washer.

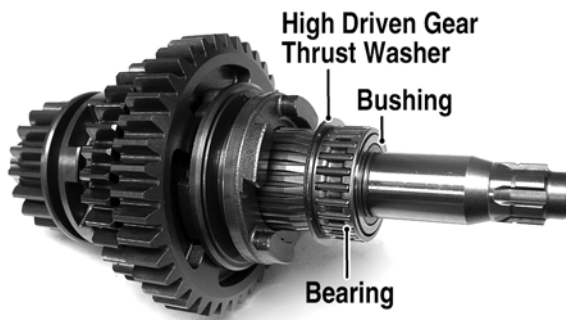

DE191A



DE166A

The countershaft is now assembled and ready for installation.

AT THIS POINT

If the drive bevel gear assembly or secondary output shaft assemblies were disassembled, use the following procedure to assemble them.

SECONDARY OUTPUT DRIVE GEARS

Initial Set-Up

■NOTE: If the secondary output drive or driven shaft is replaced or disassembled, the initial set-up must be performed to establish correct gear tooth contact. If only the secondary output driven gear or shaft are replaced, proceed to Correcting Backlash in this sub-section.



DE655A

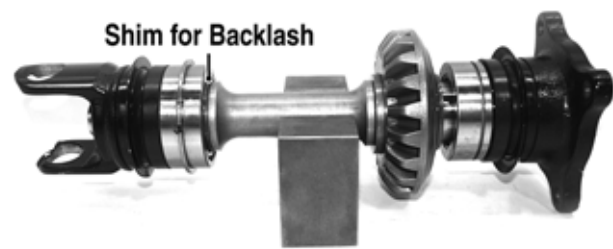

DE659A

1. Place the spacer on the output shaft; then press the secondary output driven gear onto the output shaft until it firmly contacts the spacer.



DE667A

2. Install the bearing race (A) and bearing (B) onto the secondary driven shaft (C) making sure the bearing locating groove is directed away from the driven gear.

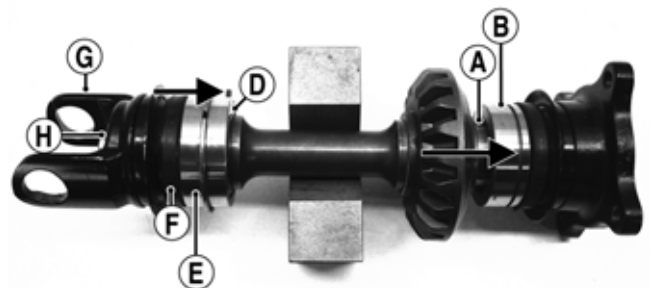

DE673A

3. Install the shim (D) (removed during disassembly); then install the output drive shaft bearing (E) making sure the locating pin is directed towards the bevel gear.
4. Install a new oil seal (F), output yoke (G), and nut (H). Tighten to 72 ft-lb.
5. Install the secondary output drive gear into the transmission using a shim as directed; then install the secondary output drive nut and using a holding fixture and tightening tool, tighten the nut to 80 ft-lb.

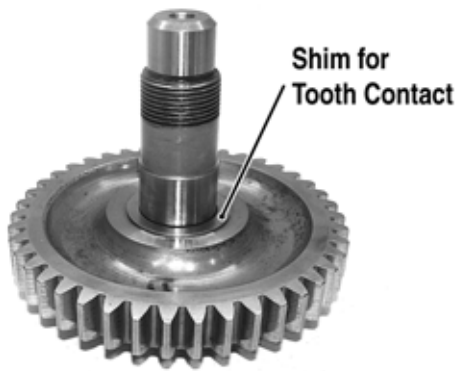

DE655A

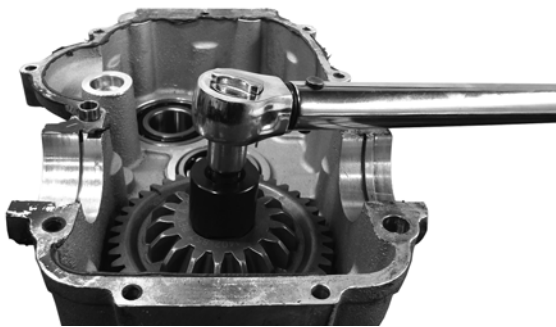

DE672

- Place the assembled secondary output driven shaft assembly (from step 4) into the transmission case; then lightly coat the teeth with machinist's dye. Rotate the shafts through several rotations in both directions. Gear contact should center between the root and top of gear teeth.

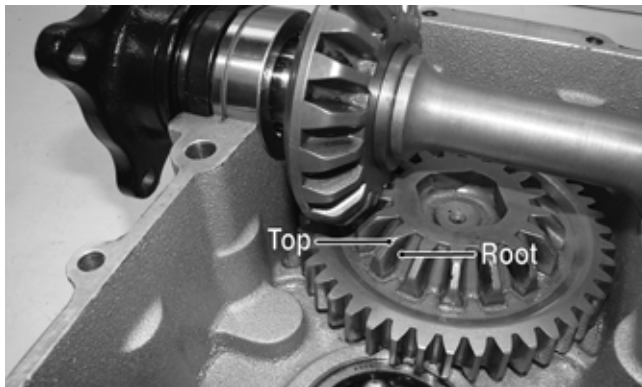

DE657A

- To adjust tooth contact, use the following chart to correctly shim the secondary bevel drive gear.

Tooth Contact	Shim Correction
Contact at Top	Increase Shim Thickness
Contact at Root	Decrease Shim Thickness

- After correct tooth contact is established, proceed to Checking Backlash in this sub-section.

Checking Backlash

- If removed, install the secondary drive/bevel gear shaft into the transmission case; then tighten the nut to 80 ft-lb.

- Install the secondary driven output shaft into the gear case and seat firmly.
- Mount the dial indicator so the tip is contacting a tooth on the secondary drive bevel gear.
- While rocking the drive bevel gear back and forth, note the maximum backlash reading on the gauge.

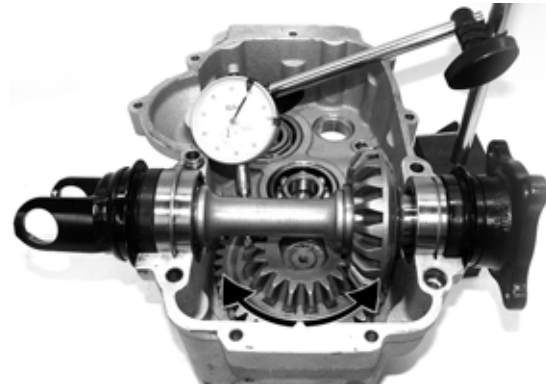

DE658A

- Acceptable backlash range is 0.127-0.381 mm (0.005-0.015 in.).

Correcting Backlash

■NOTE: If backlash measurement is within the acceptable range, no correction is necessary.

- If backlash measurement is less than specified, remove an existing shim, measure it, and install a new thicker shim.
- If backlash measurement is more than specified, remove an existing shim, measure it, and install a thinner shim.

■NOTE: Continue to remove, measure, and install until backlash measurement is within tolerance. Note the following chart.

Backlash Measurement	Shim Correction
Under 0.127 mm (0.005 in.)	Increase Shim Thickness
At 0.127-0.381 mm (0.005-0.015 in.)	No Correction Required
Over 0.381 mm (0.015 in.)	Decrease Shim Thickness

After backlash and tooth contact are within specifications, apply red Loctite #271 to the driveshaft threads and driven output shaft threads; then using new nuts, tighten the output drive shaft nut to 80 ft-lb and the output drive yoke nut to 72 ft-lb.

Assembling Gear Case

- Install new bearings and seals in the left-side and right-side cases as required.

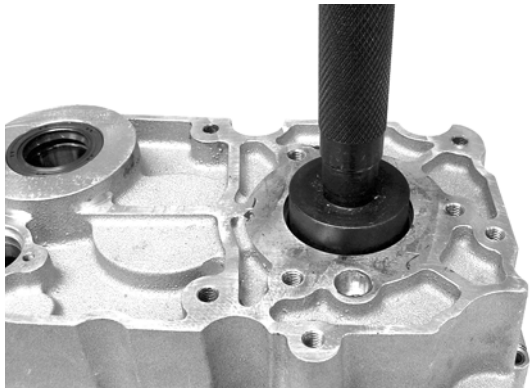

DE170

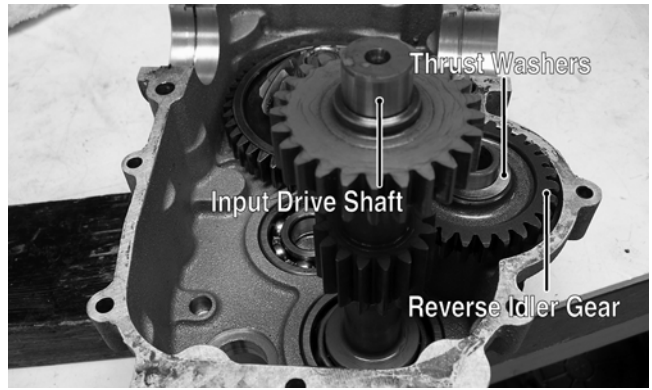

DE192A

3. Install the assembled countershaft assembly taking care to position a washer on each end.



DE169

2. Install the reverse idler gear making sure to install a washer on each side of the gear; then install the input driveshaft.



DE142

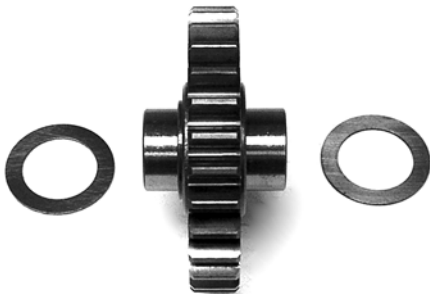

DE179

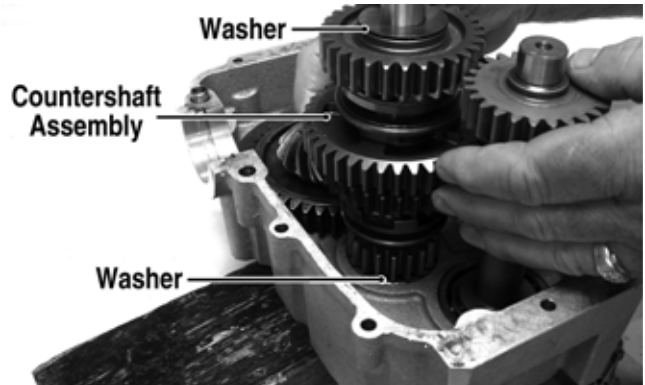

DE193A

4. Install the reverse shift fork; then install the gear shift shaft making sure the spacer is installed as shown and the washer is in place.



DE140

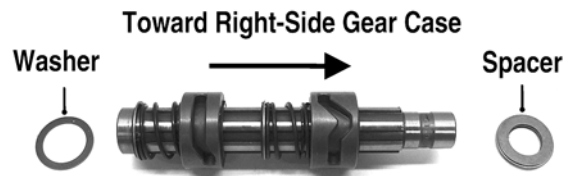

DE677B

5. Install the high/low shift fork and engage the fork in the high/low cam slot in the gear shift shaft; then install the shift fork shaft.

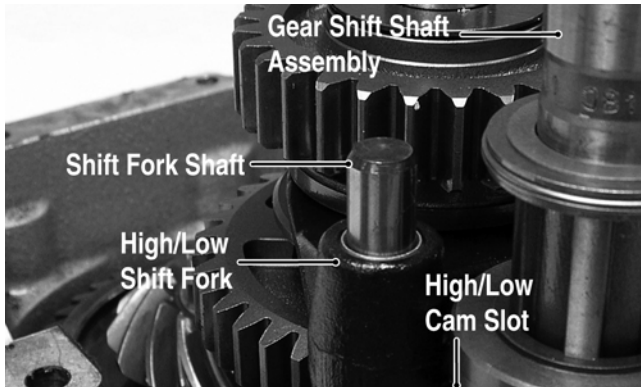

DE136A

6. Install the secondary output driveshaft aligning the front bearing alignment ring with the groove in the gear case and rotate the bearing to locate the bearing anchor pin in the slot; then align the groove in the rear bearing with the case groove and install the C-ring.

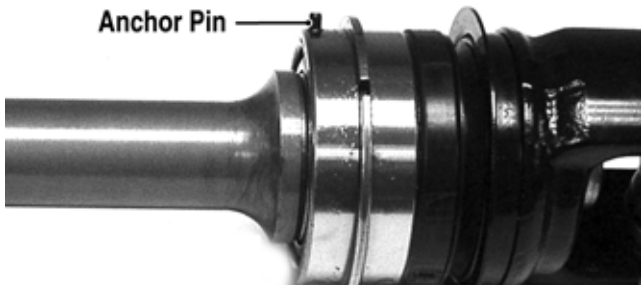

DE135A

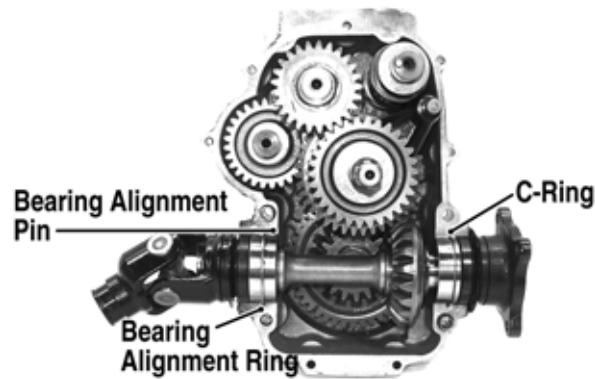

DE663D

7. Apply a thin layer of Three Bond Sealant to the mating surface of the right-side gear case; then make sure that the alignment pins and washers are positioned as shown and join the gear case halves. Do not force the gear case halves together.

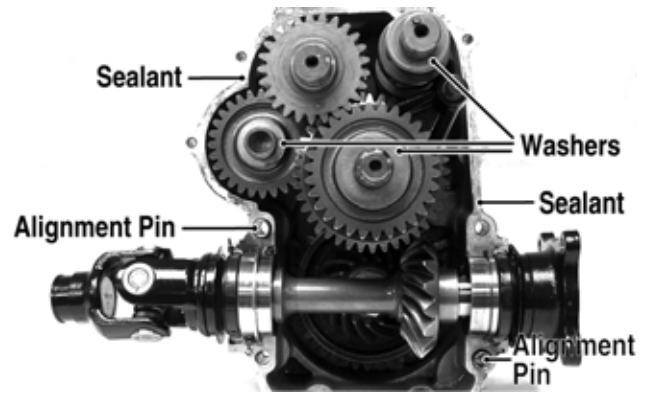

DE133D

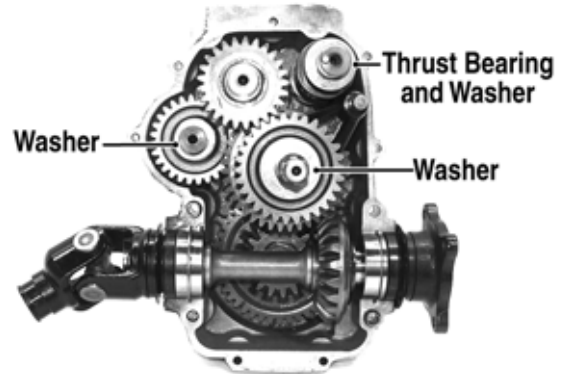

DE663A

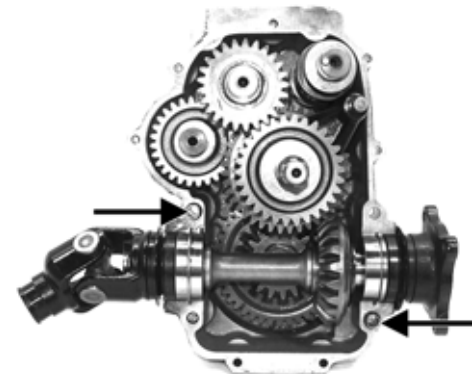

DE663C

8. From the right side, install the gear case cap screws and using the pattern shown, tighten until the gear case halves are finally joined, turning the shafts frequently to assure no binding occurs; then tighten to 8 ft-lb.

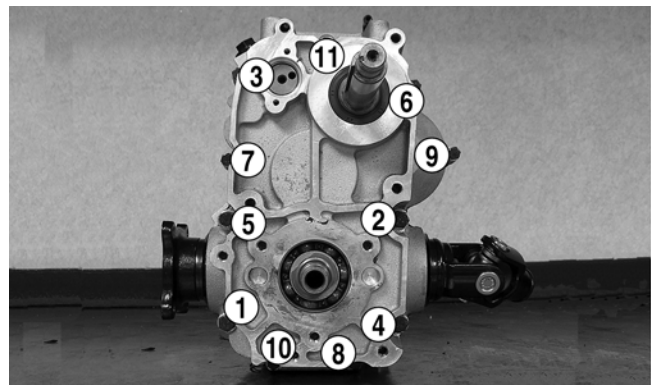

DE130B

9. Install the speed sensor trigger and secure with the circlip; then install the speed sensor housing and secure with the cap screws. Tighten securely.

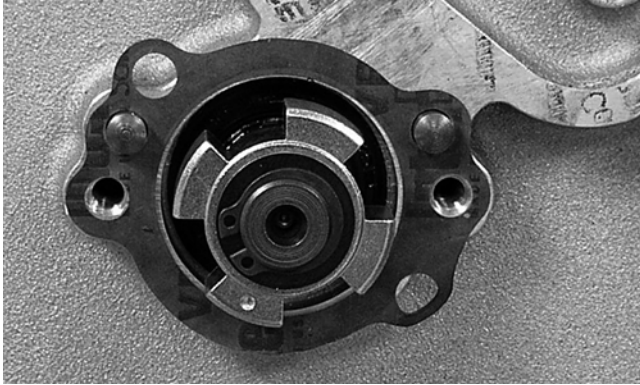

DE126

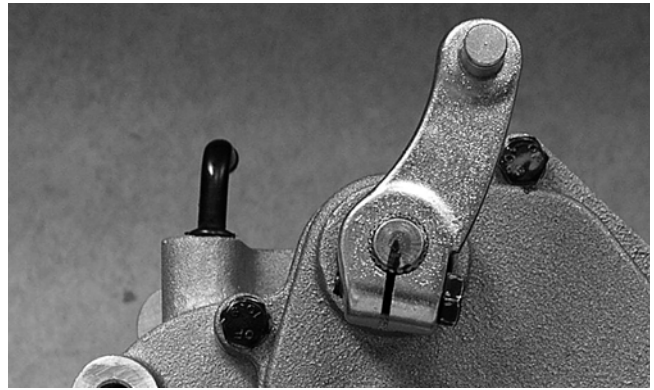

DE119

12. Apply Three Bond Sealant to the secondary output shaft bearing housing; then install on the transmission and tighten securely.

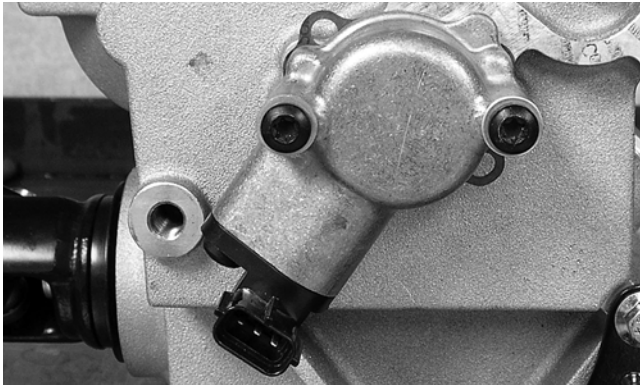

DE125

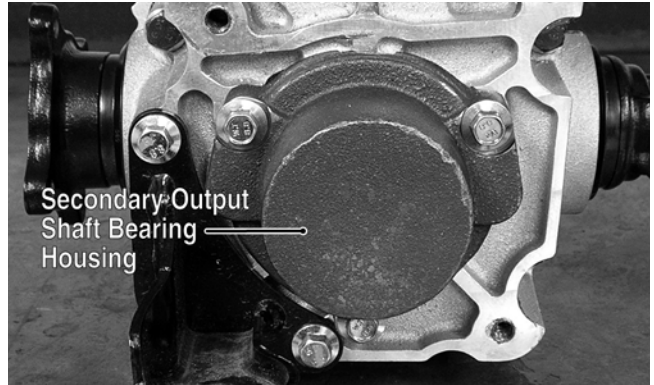

Secondary Output
Shaft Bearing
Housing

DE117A

10. Install the gear shift cam plate, cam arm stopper, and gear shift sub shaft as shown making sure to align the timing marks. Tighten all fasteners securely.

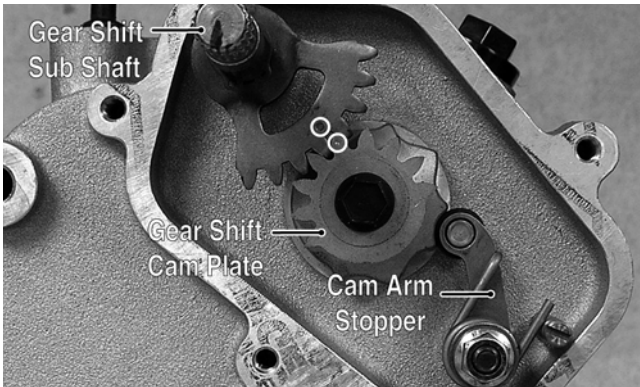

Gear Shift
Sub Shaft

Gear Shift
Cam Plate

Cam Arm
Stopper

DE121A

13. Install two springs and two contact pins in the end of the gear shift shaft; then install the gear position switch with a new O-ring and tighten the cap screws securely.



Contact Pins

DE116A

11. Using a new gasket, install the shift shaft housing and secure with existing cap screws; then install the shift arm aligning the mark with the slot. Tighten all fasteners securely.

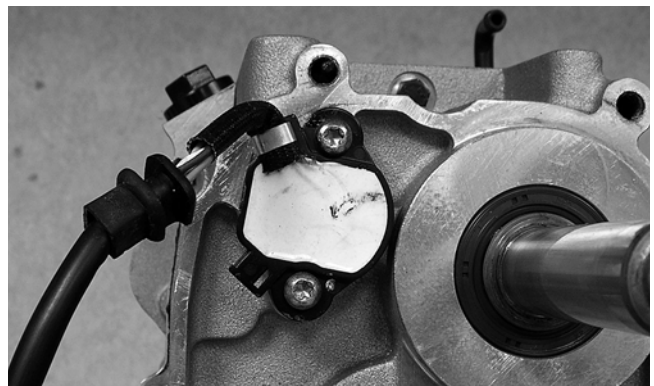

DE115

14. Install the left and right transmission mounting brackets and tighten the cap screws securely. The transmission is now ready to be installed on the V-belt housing.

Center Components

■NOTE: This procedure cannot be done with the engine in the frame. Complete Removing procedures for Top-Side, Left-Side, and Right-Side must precede this procedure.

■NOTE: For efficiency, it is preferable to remove and disassemble only those components which need to be addressed and to service only those components. The technician should use discretion and sound judgment.

ENGINE BLOCK ASSEMBLY

Removing

1. Remove the engine/transmission assembly (see Removing Engine/Transmission in this section).
2. Separate the transmission and V-belt housing from the engine (see Right-Side Components in this section).
3. Remove the timing belt (see Left-Side Components in this section).
4. Remove the cylinder head assembly (see Top-Side Components in this section).
5. Remove the oil pump assembly (see Left-Side Components in this section).
6. Remove the cap screws securing the oil pan assembly; then remove the oil pan assembly. Account for two O-rings and a gasket.



DE332A

7. Remove the four cap screws securing the water pump to the engine block; then remove the pump assembly.

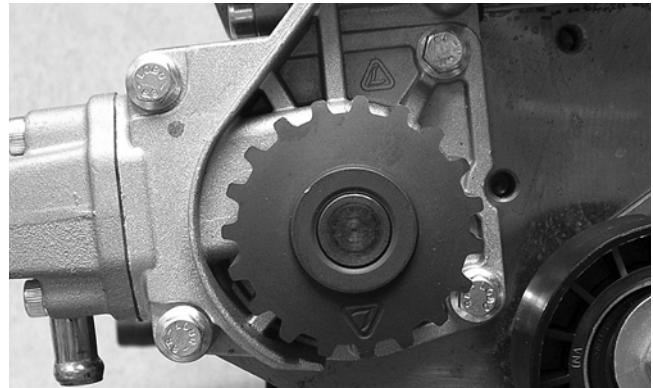

DE267

8. Measure piston protrusion using the following procedure.

- A. Rotate the crankshaft until one of the pistons is at top-dead-center (TDC) as indicated by a dial indicator.



DE330

- B. Using a depth micrometer, measure and record piston protrusion above the cylinder deck plane.

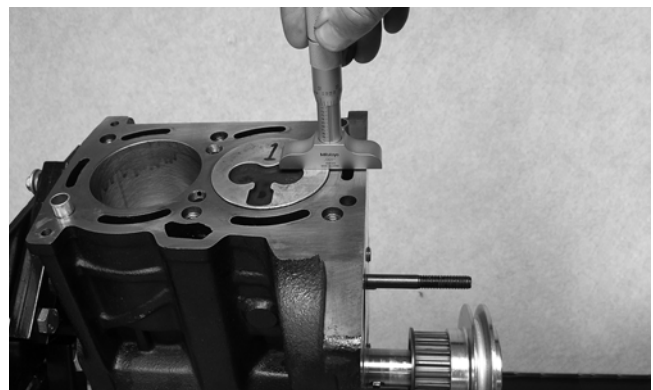

DE386

- C. Using the same procedure, measure and record the second piston protrusion.
- D. Mark the piston with the highest protrusion and record that value for use later in this section.



DE390A

9. Mark the pistons, connecting rods, and connecting rod caps for installing purposes; then rotate the crankshaft so that one connecting rod is at bottom-dead-center (BDC).



DE580

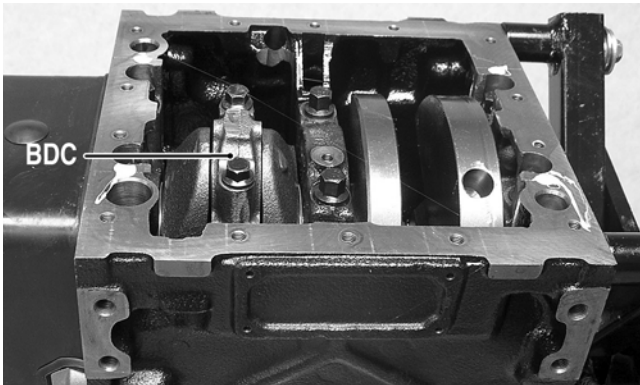

DE440A

10. Remove the two cap screws from the connecting rod cap and remove the cap. Account for one bearing insert.

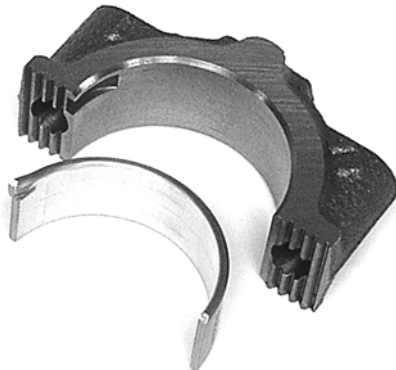

DE600

11. Rotate the crankshaft carefully until the second connecting rod is at BDC; then using a large wooden dowel or hammer handle, carefully push against the first connecting rod until the piston/connecting rod assembly is free of the cylinder bore.

■NOTE: If the piston “hangs-up” at the top of the cylinder, it may be necessary to cut the ridge with an appropriate ridge reamer.

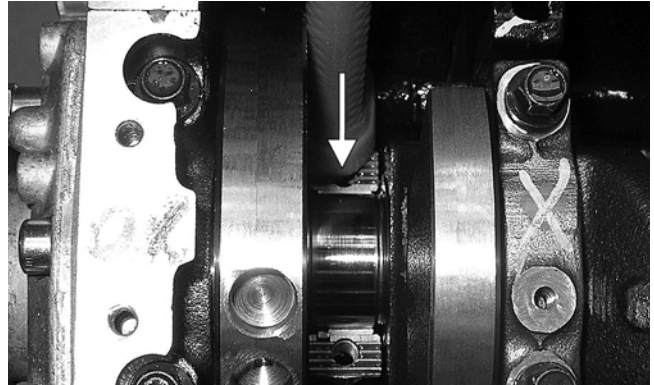

DE599A

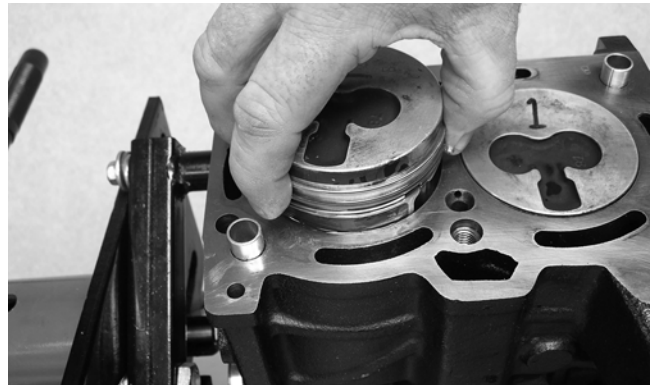

DE394

12. Attach the connecting rod cap with bearing inserts and loosely install the cap screws keeping the assemblies together.



DE602

CAUTION

The connecting rod and connecting rod cap are matched components and cannot be interchanged or replaced separately. If matched components are interchanged or reversed, severe engine damage WILL occur.

13. Remove the two cap screws from the second connecting rod cap and remove the cap. Account for one bearing insert.

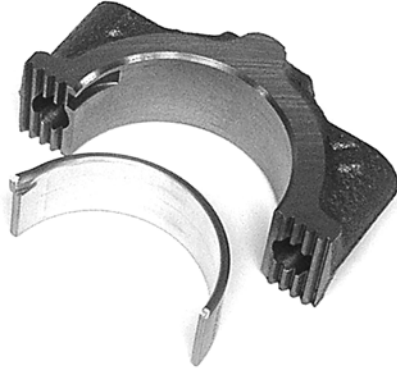

DE600

14. Carefully rotate the crankshaft 180°; then gently push the piston/connecting rod assembly from the cylinder bore.

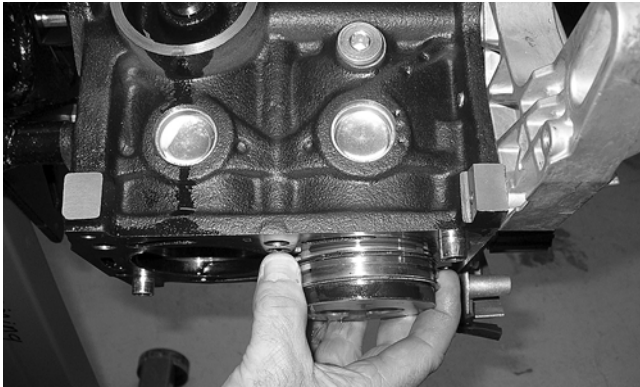

DE629

15. Attach the connecting rod cap with bearing inserts and loosely install cap screws keeping the assemblies together.
16. Use an appropriate thickness gauge to measure the crankshaft end play at the thrust bearing surface. Record this measurement.



DE435A

17. Mark the main bearing caps and engine block for proper orientation; then remove the cap screws securing the main bearing caps to the main bearing saddles in the engine block.

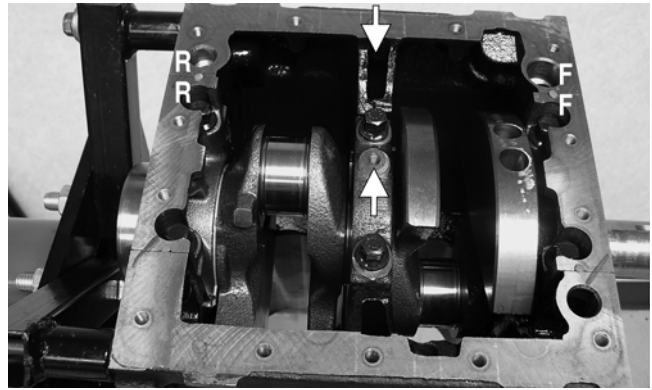

DE335C

18. Lightly rock the bearing caps in the saddles while applying pressure away from the crankshaft until the bearing cap is free of the engine block. Account for a bearing insert for each cap and two thrust bearing inserts for the flywheel-end bearing cap.

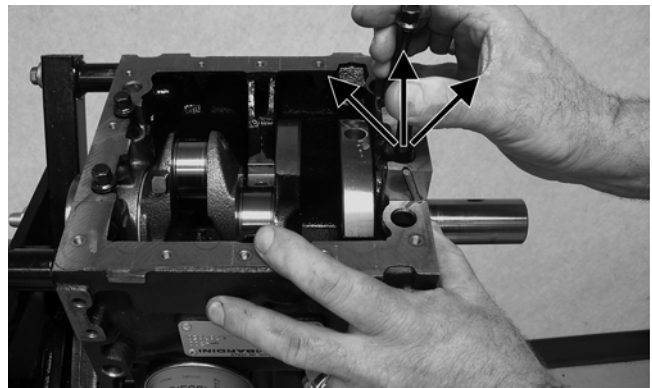

DE336A

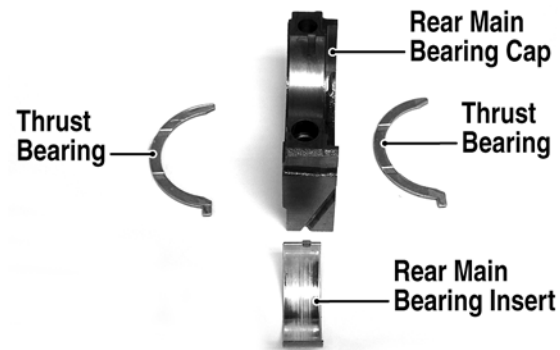

DE346A

19. Carefully lift the crankshaft from the main bearing saddles and set the crankshaft aside.

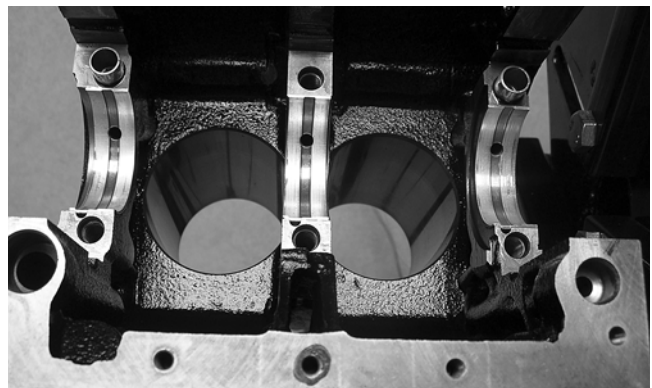

DE376

■NOTE: The crankshaft should be supported in the three main bearing journal locations or stood on the flywheel end. Do not drop or strike the crankshaft.

20. Set main bearing caps with inserts into the main bearing saddles and install cap screws. Finger tighten only.

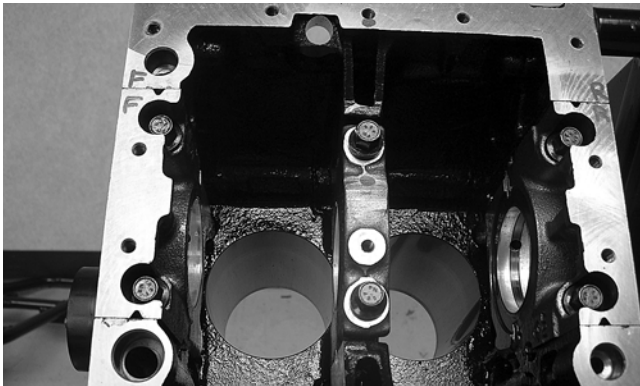

DE605

Cleaning and Inspecting

1. Clean all gasket material, sealant, varnish, and carbon from the engine block mating and sealing surfaces.

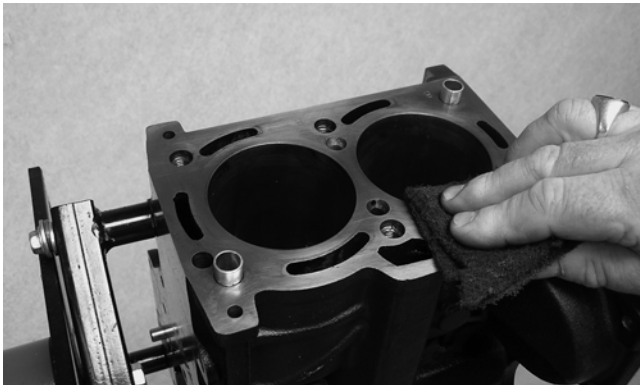

DE338

2. Remove the main bearing inserts from the main bearing caps and saddles; then set the caps aside in order.

■NOTE: If main bearing inserts are to be used again, mark their locations for correct positioning during installing.

3. Using appropriate thread taps, clean up the main bearing and cylinder head cap screw thread bores.

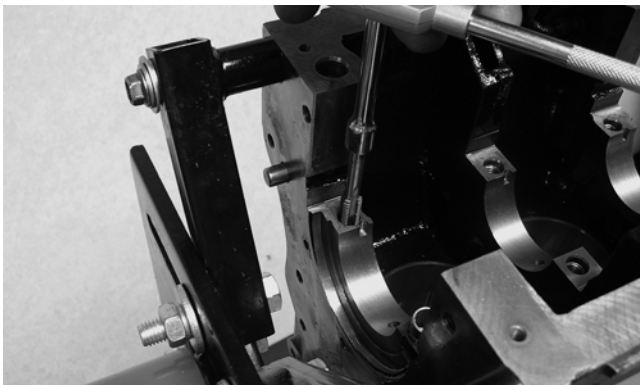

DE339

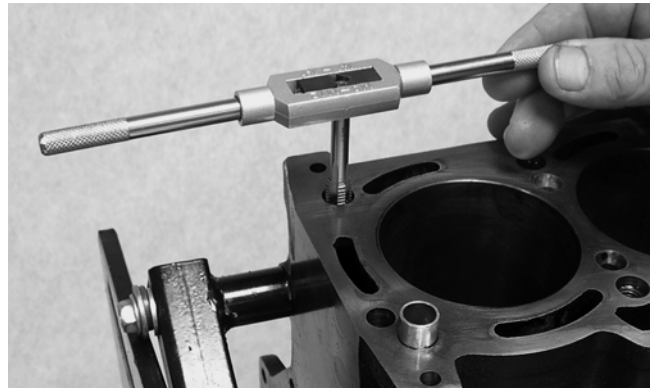

DE349

4. Install main bearing caps into their appropriate saddles; then finger-tighten the cap screws.

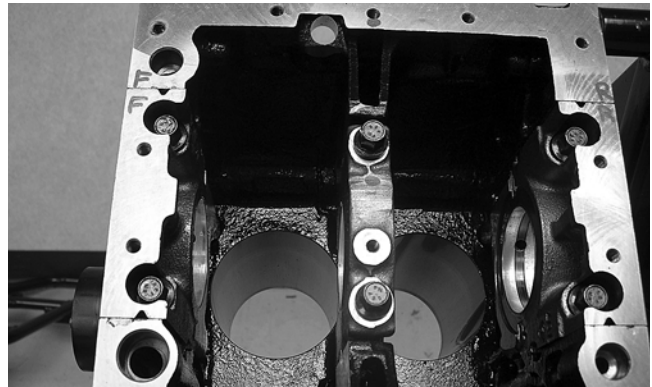

DE605

5. Make sure the cylinder deck plane is completely free of all gasket material, carbon, and sealant; then using a precision straight edge and feeler gauge, check for cylinder deck trueness. Maximum variation must not exceed 0.1 mm (0.0039 in.).

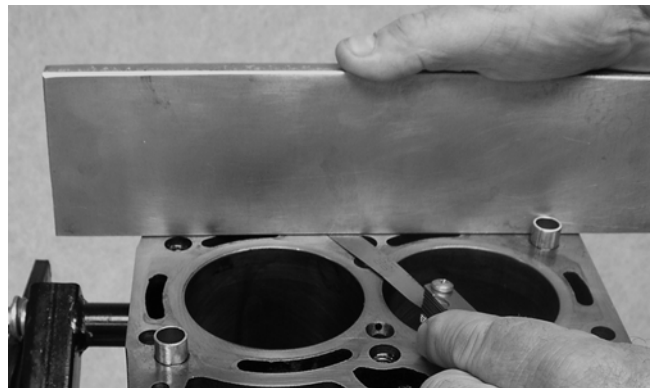

DE348



DE347

■NOTE: Planing the engine block is not recommended as it will directly affect piston-to-cylinder head clearance. To determine if the cylinder deck can be planed, use the following procedure.

- A. Determine the maximum cylinder deck variation (V_d).
- B. Add the deck variation (V_d) to the piston protrusion (P_p) determined during removing ($V_d + P_p$) to determine final piston protrusion (P_{pf}). $V_d + P_p = P_{pf}$.
- C. Compare the final piston protrusion (P_{pf}) to the chart to determine if gaskets are available that would allow planing of the cylinder deck.

Final Piston Protrusion (P_{pf})	Gasket Thickness	# of Holes
0.82-0.91 mm (0.032-0.036 in.)	1.56-1.64 mm (0.061-0.065 in.)	1
0.92-1.01 mm (0.036-0.040 in.)	1.66-1.74 mm (0.065-0.069 in.)	2
1.02-1.10 mm (0.040-0.043 in.)	1.76-1.84 mm (0.069-0.072 in.)	3

Example 1:

$$P_p = 0.82 \text{ mm (0.032 in.)}$$

$$V_d = 0.13 \text{ mm (0.005 in.)}$$

$$0.82 + 0.13 = 0.95 \text{ mm (0.037 in.)}$$

$$P_{pf} = 0.95 \text{ mm (0.037 in.)}$$

Using the preceding chart, the middle gasket could be used; therefore, the cylinder deck could be planed sufficiently to be salvaged.

Example 2:

$$P_p = 0.82 \text{ mm (0.032 in.)}$$

$$V_d = 0.30 \text{ mm (0.012 in.)}$$

$$0.82 + 0.30 = 1.12 \text{ mm (0.044 in.)}$$

$$P_{pf} = 1.12 \text{ mm (0.044 in.)}$$

Using the preceding chart, it can be determined that no gasket would be available to allow sufficient piston-to-cylinder head clearance; therefore the engine block must be replaced.

D. If engine block is not serviceable, it must be replaced with a new block.

6. Thoroughly clean the engine block using a non-caustic engine cleaning solution; then rinse with hot water and dry with compressed air.

⚠ WARNING
Always wear safety glasses when using compressed air.

7. Using a cylinder bore gauge or suitable snap gauge and micrometer, measure the cylinder bore at three locations taking measurements at 45° intervals. If the cylinder is found to be 72.050 mm (2.836 in.) or greater at any measurement point, the cylinder(s) must be bored. Oversized pistons/rings are available in 0.50 mm (0.020 in.) and 1.00 mm (0.039 in.) sizes.

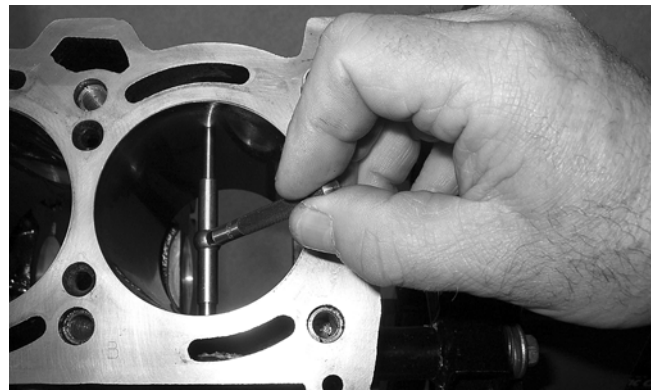

DE369

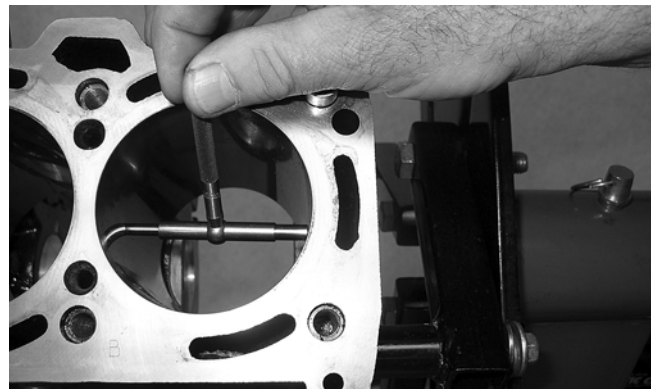

DE350

8. Using a suitable ridge reamer tool, clean the top of the cylinder bore; then using a ball hone, hone the cylinders to produce a 45-55° cross-hatch.

■NOTE: To produce the proper 45-55° cross-hatch pattern, use a low-RPM drill (600 RPM) at the rate of 25 strokes per minute. Use honing oil or lightweight petroleum-based oil. Thoroughly clean the cylinder after honing using soap and hot water. Dry with compressed air; then immediately apply engine oil to the cylinder bore. If the bore is severely scored or out of round, the cylinders must be bored.

⚠ WARNING
Always wear safety glasses when using compressed air.

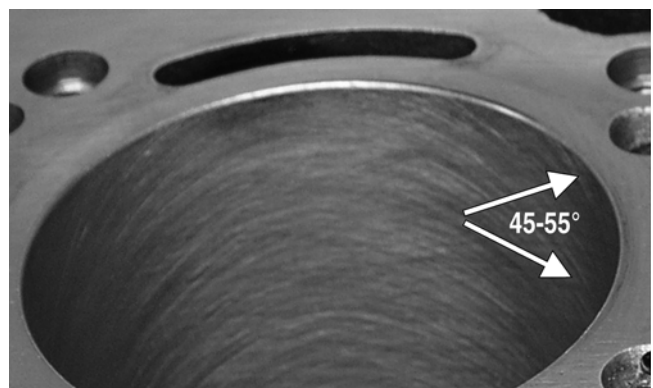

DE398B

9. Lightly coat all non-painted surfaces, thread bores, and cap screw threads with clean engine oil.

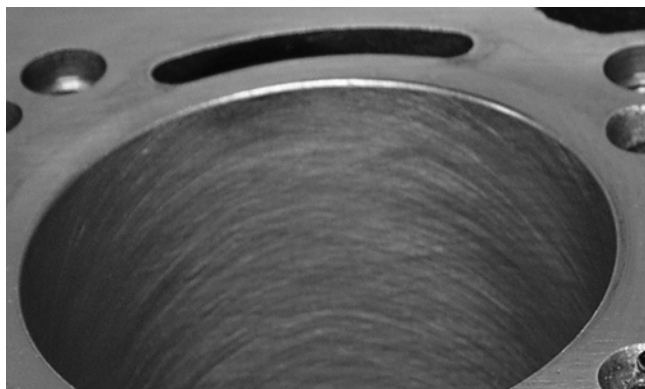

DE398



DE363

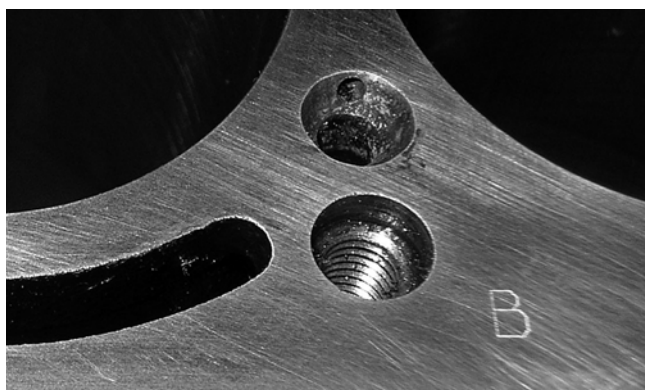

DE356



DE362

10. Wash the crankshaft, connecting rods, and oil pan and cover in parts-cleaning solvent; then dry with compressed air.

⚠ WARNING

Always wear safety glasses when using compressed air.

11. Using a suitable micrometer, carefully measure the crankshaft main bearing and connecting rod journals at 45° intervals around the entire circumference of the journal. Journal measurements must be within specifications.



DE360

■ **NOTE:** Undersized connecting rod and main bearings are available in 0.25 mm (0.010 in.) and 0.50 mm (0.020 in.) sizes. Use of undersized bearings will require the crankshaft journals to be machined to the correct size by a qualified machine shop.

12. Lightly coat the crankshaft journals with clean oil. If no machining is required, set aside until assembly.

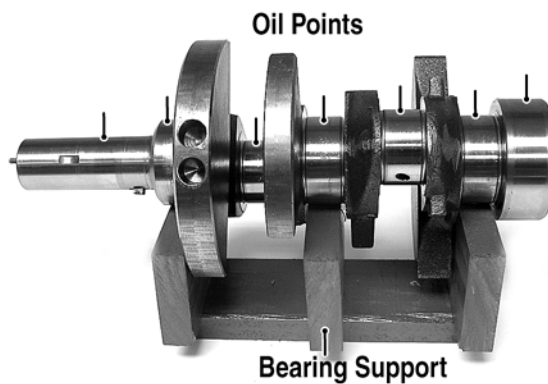

DE620A

CAUTION

Always support the crankshaft equally at the main bearing journals or stand the crankshaft on the flywheel end. Do not drop or strike the crankshaft or engine damage caused by crankshaft misalignment may occur.

13. Remove the main bearing caps from the main bearing saddles; then install the bearing inserts into the correct locations.

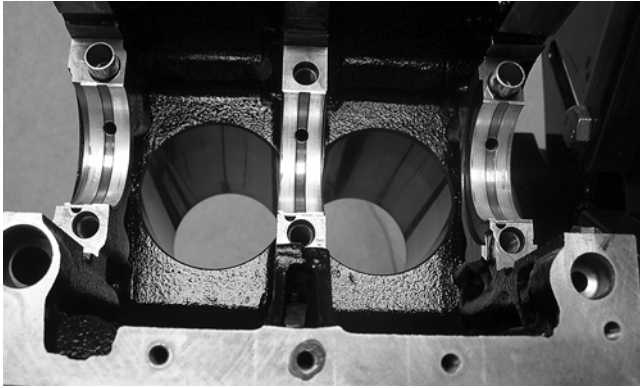

DE376

14. Install the main bearing caps and tighten to 44 ft-lb; then being careful not to mar the inserts, measure the main bearing bores using an appropriate inside micrometer/snap gauge. Record the measurements.

16. Subtract the crankshaft journal measurement from the corresponding main bearing bore. The clearance must be within specifications.



DE609A



DE609



DE614A

17. Install the bearing inserts to be used for assembly in the connecting rods; then secure the connecting rod in a suitable holding fixture.



DE610

15. Measure the crankshaft main bearing journals and record the measurements.



DE368

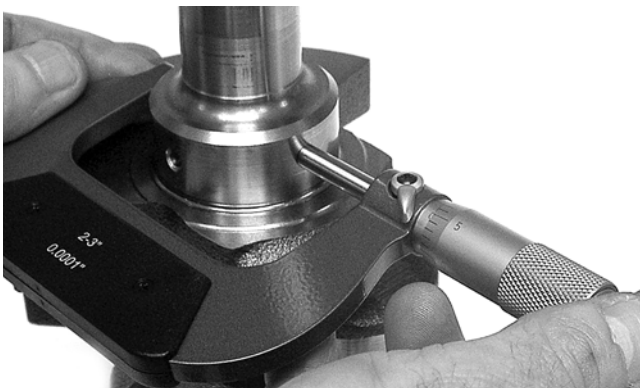

DE619

CAUTION

If a vise is used to secure the connecting rod it must have brass, copper, or hardwood jaws to prevent damage to the connecting rod. Never use a bench vise without jaw protection or severe damage to the connecting rod and engine will occur.

18. Tighten the connecting rod cap screws to 29 ft-lb in 7 ft-lb increments.



DE352

19. Using an appropriate inside micrometer, measure the inside diameter of the connecting rod bearing insert. It must be within specifications or the bearings or connecting rod must be replaced.



DE623

22. Examine the piston pin bushing for galling or discoloration. If either condition exists, replace the bushing or connecting rod.



DE612

20. Measure the inside diameter of the connecting rod piston pin bushing. It must be within specifications.



DE623A

23. Measure the piston pins making sure to keep them with their respective piston/connecting rod. The piston pins must measure within specifications.

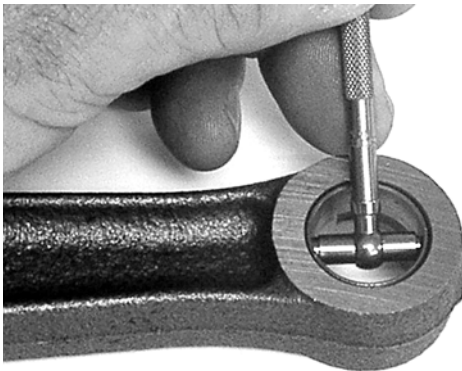

DE366

■NOTE: If the piston pin bushing is replaced, the lubrication hole must be aligned and the bushing sized. It is recommended that only a qualified machine shop replace bushings.

21. Examine the connecting rods for nicks, gouges, discoloration, and stress lines.

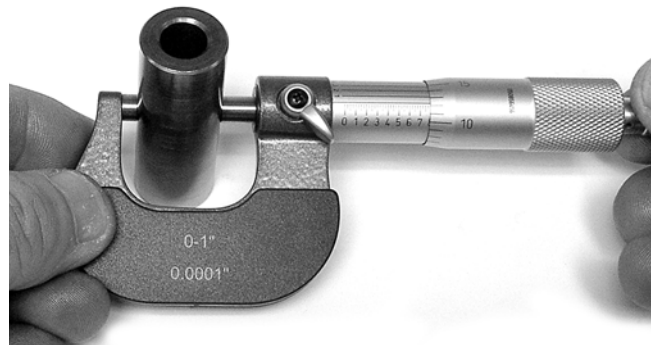

DE351

24. Making sure pistons are clean and ring lands are free of carbon deposits, measure ring to ring-land clearance using new piston rings. If ring to ringland clearance is excessive, new pistons must be installed.

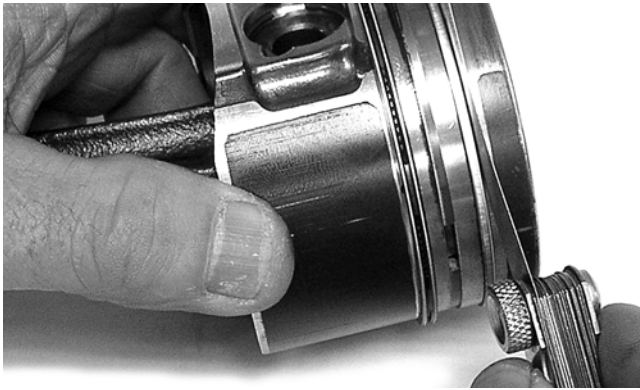

DE367

25. Using a suitable outside micrometer, measure piston skirt diameter at a distance of 9 mm (0.350 in.) from the bottom of the skirt and 90° from the piston pin axis. Pistons and cylinder measurements must be within specifications as listed in the following chart. Class markings are stamped on the cylinder deck.



DE354

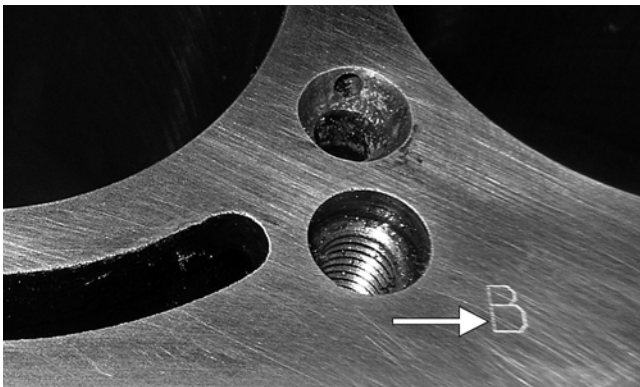

DE356B

Class	Cylinder Diameter	Piston Diameter	Clearance
A	74.990-75.000 mm (2.9523-2.9527 in.)	74.930-74.940 mm (2.9499-2.9503 in.)	0.050-0.070 mm (0.002-0.003 in.)
B	75.000-75.010 mm (2.9527-2.9531 in.)	74.940-74.950 mm (2.9503-2.9508 in.)	0.050-0.070 mm (0.002-0.003 in.)
C	75.010-75.020 mm (2.9531-2.9535 in.)	74.950-74.960 mm (2.9508-2.9512 in.)	0.050-0.070 mm (0.002-0.003 in.)

■NOTE: Replacement pistons are only supplied as class A. Class B and C are reserved for production engines. Replacement pistons are available oversized by 0.50 mm (0.020 in.) and 1.00 mm (0.039 in.) and are supplied with piston rings.

CAUTION

Do not attempt to use standard rings on oversized pistons or oversized rings on standard pistons. Severe engine damage will occur.

■NOTE: The engine block must be bored in order to install oversized pistons.

26. Thoroughly clean all components after machining to insure no filings or metal chips are present. Blow out all oil galleys with compressed air.

WARNING

Always wear safety glasses when using compressed air.

Installing

1. Mount the engine block on a suitable engine stand; then install the upper main bearing inserts into the main bearing saddles making sure the oil holes in the inserts are aligned with the oil galleys in the saddles and the locating tabs are oriented in the reliefs.

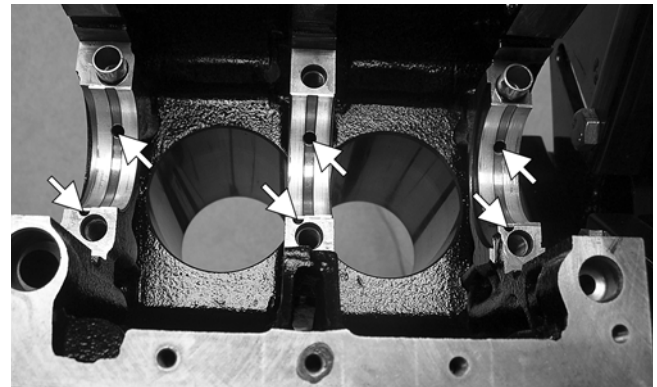

DE376A

2. Install the thrust bearing inserts into the rear main bearing saddle using a small amount of oil-soluble grease to hold them in place.



DE628A

3. Install the lower main bearing inserts into the main bearing caps; then install the thrust bearing inserts into the rear main bearing cap using oil-soluble grease to hold in place.

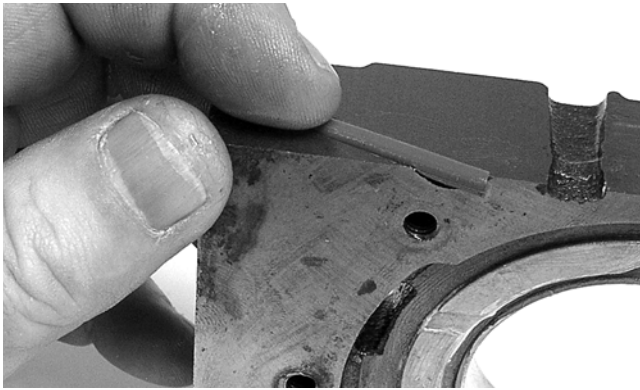

DE431

4. Apply a liberal amount of clean engine oil to the crankshaft main bearing journals and the main bearing saddles; then carefully install the crankshaft into the engine block.

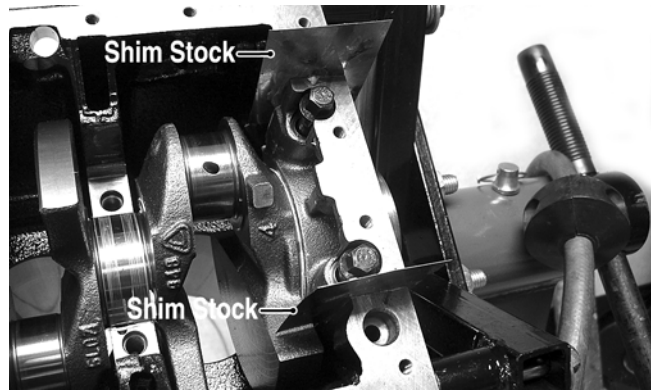

DE377A

7. Remove the Main Bearing Seal Installation Tool or shim stock; then install the main bearing cap screws.

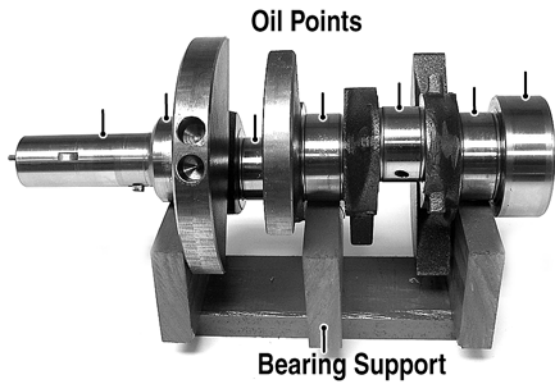

DE620A

5. Thoroughly coat the lateral seals with oil-soluble grease; then install them in the front and rear main bearing caps.

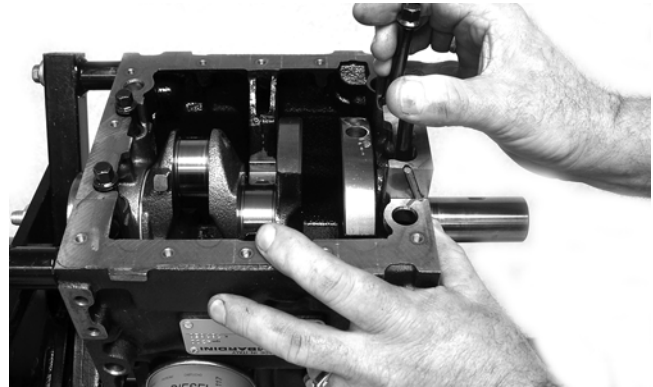

DE336

8. Install the center main bearing cap and finger tighten the cap screws.

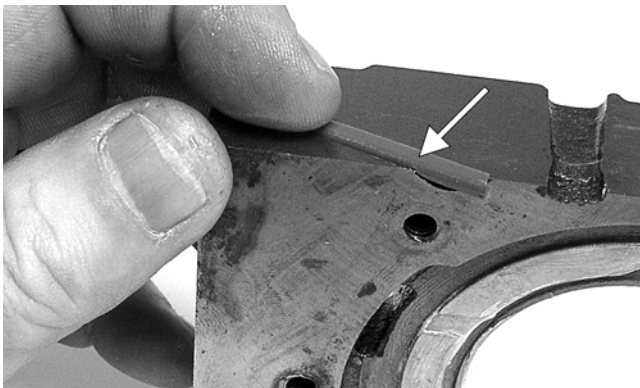

DE431A

6. Using Main Bearing Seal Installation Tool or 0.07 mm (0.003 in.) shim stock as shown, slide the main bearing cap into position in the main bearing saddle being careful to keep the seals from sliding out of place.

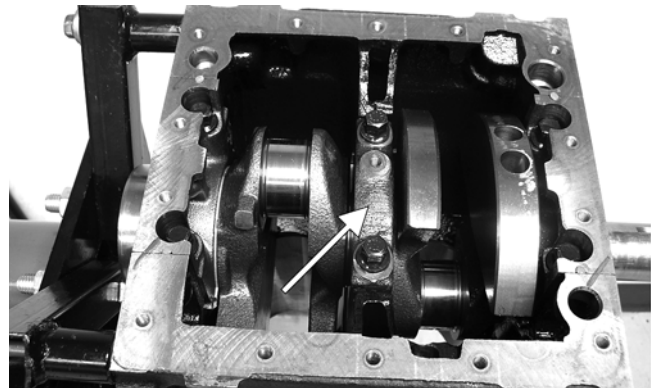

DE335B

9. Tighten the main bearing caps to 44 ft-lb in 7 ft-lb increments.

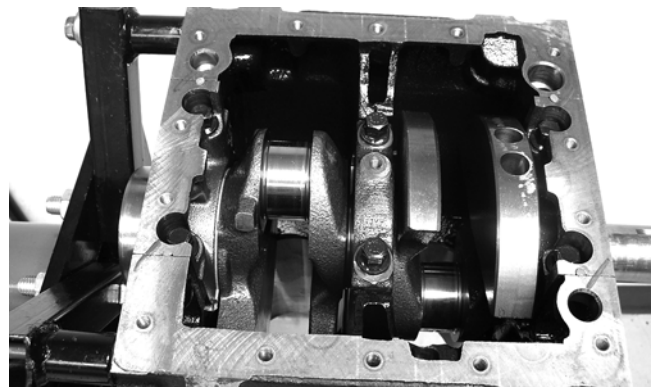

DE335

10. Rotate the crankshaft to make certain that no binding exists.
11. If pistons were removed from connecting rods, install the pistons onto the connecting rods making sure the piston pin retainer clips are properly seated and the open ends are orientated facing downward.



DE371A

12. Check piston ring gap by installing the ring in the cylinder bore and using a piston turned upside down, push the ring down 25 mm (1.0 in.) into the piston bore.

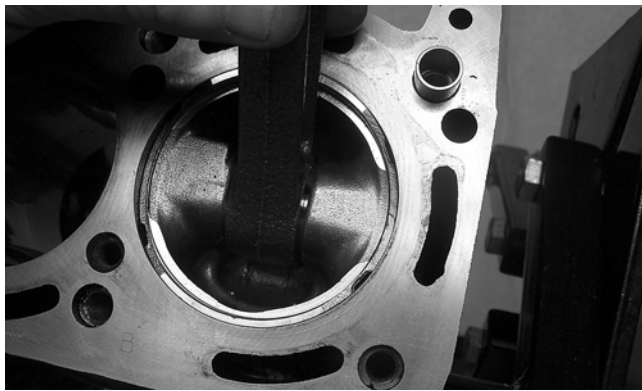

DE374

13. Using an appropriate thickness gauge, measure the ring end gap. End gap must be according to specifications.

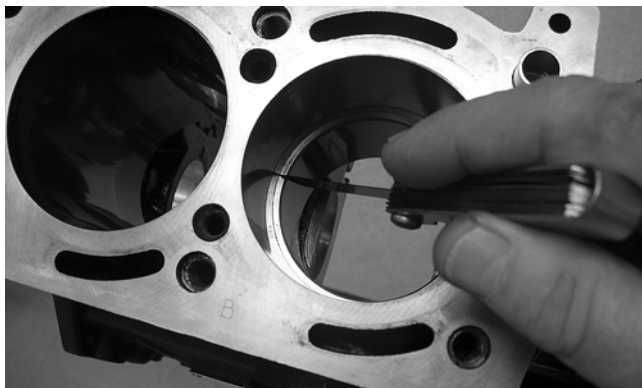

DE375

■NOTE: If ring gap is less than specified, install the ring in a soft-jawed vise and use a fine flat file to file the ends of the ring, checking end gap frequently.

14. After all piston ring end gaps are within specifications, install the rings on the pistons using the following procedure.

- A. Place the oil expander ring in the 3rd (bottom) ring groove; then install the oil scraper ring over the expander making sure the oil scraper ring end gap is not directly in line with the expander spring ends.
- B. Install the 2nd (middle) compression ring in the middle ring groove with the TOP or UP markings on the ring directed toward the top of the piston.
- C. Install the 1st (top) compression ring in the top ring groove with the TOP or UP markings on the ring directed toward the top of the piston.

■NOTE: The top compression ring is full chrome (silver) and the middle compression ring has a partial chrome band on the bottom side. Both rings have a chamfered inner radius. The chamfer must be directed upward.

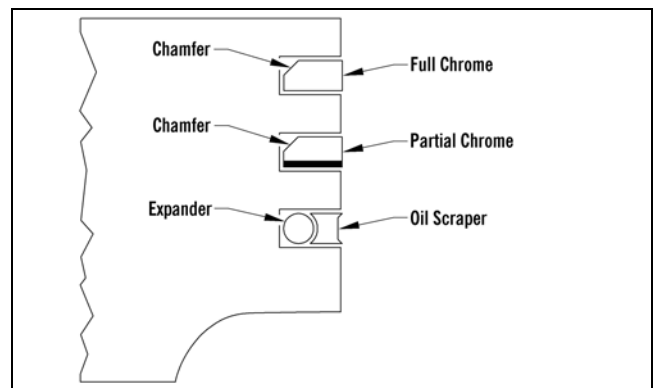

0742-252

15. Remove the connecting rod caps keeping bearing inserts in place; then position the rings on the pistons as shown in the following illustration.

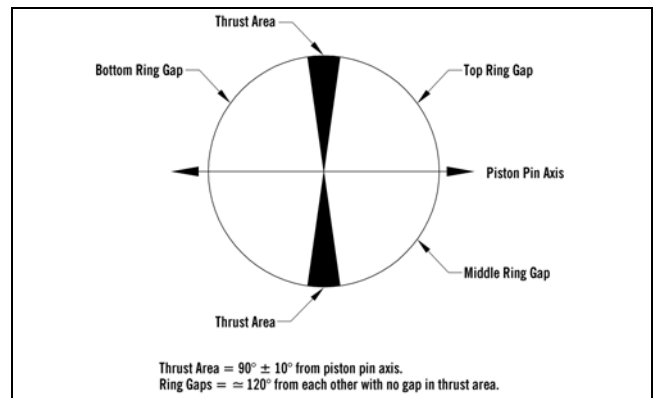

Thrust Area = $90^\circ \pm 10^\circ$ from piston pin axis.
 Ring Gaps = $\approx 120^\circ$ from each other with no gap in thrust area.

0742-253

16. Apply clean engine oil to the rings and cylinder wall; then using a suitable ring compressor, compress the rings sufficiently to install the piston in the cylinder.

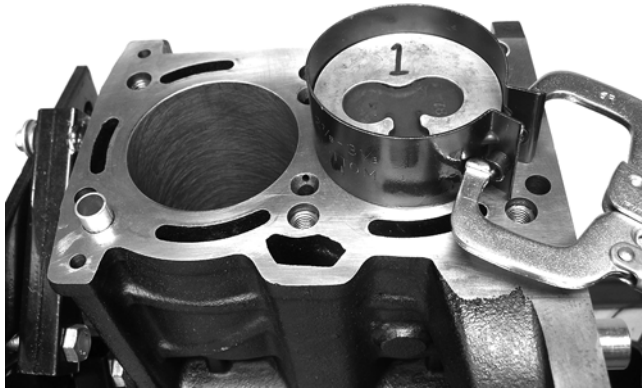

DE392

17. Rotate the crankshaft so the crankshaft rod journal corresponding to the piston being installed is at bottom-dead-center (BDC).

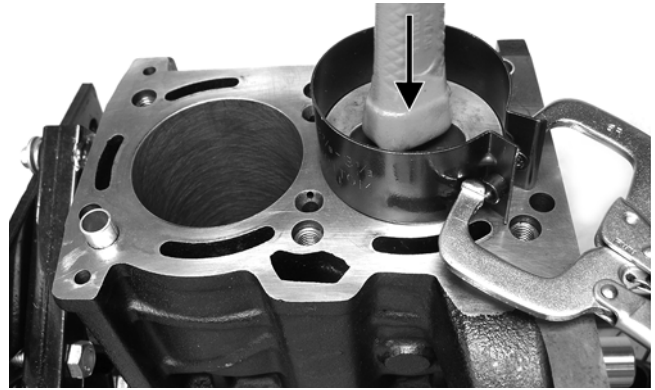

DE393A

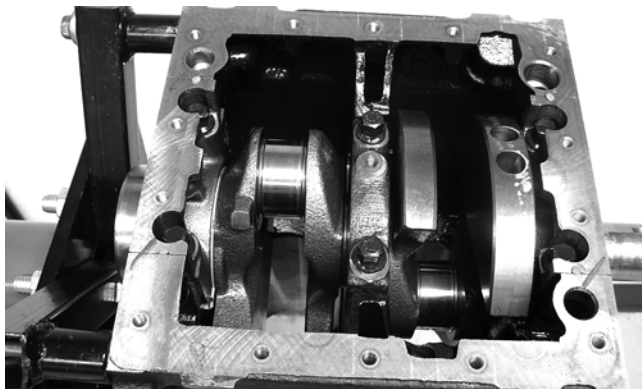

DE335

18. Place the piston/rod assembly into the cylinder making sure the turbulence chamber in the top of the piston is directed toward the water pump side of the engine.



DE390

CAUTION

NEVER force the piston into the cylinder. If sudden resistance is encountered, remove and start over as rings may not have been compressed sufficiently. Forcing will cause severe ring and/or ring land damage.

20. While carefully guiding the connecting rod onto the crankshaft journal, push or “bump” the top of the piston until the connecting rod is seated on the crankshaft.

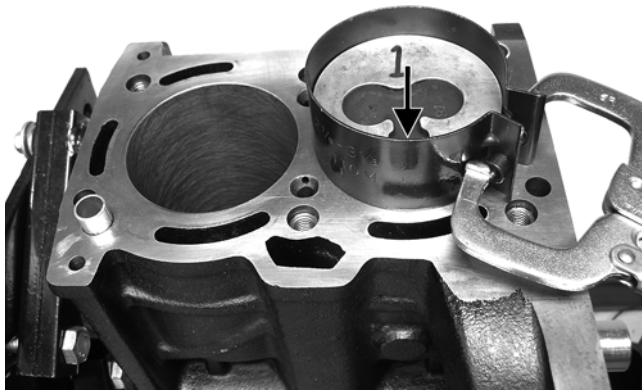

DE392A

19. Using a wooden dowel or hammer handle, gently “bump” the piston into the cylinder. Stop when the piston is clear of the ring compressor.

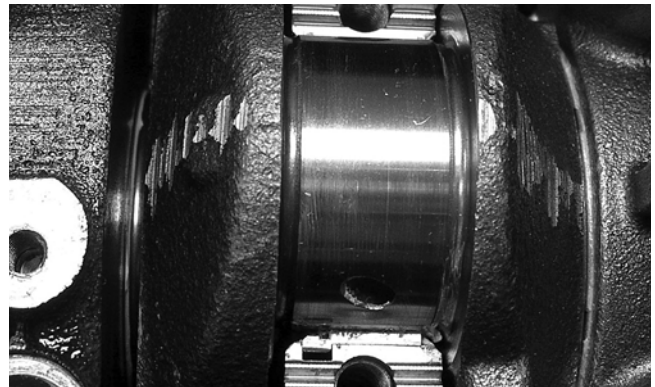

DE436

21. Apply clean engine oil to the crankshaft journal and connecting rod cap bearing insert; then making sure the connecting rod cap is correctly oriented to the connecting rod, install the rod cap and secure with the cap screws. Tighten to 29 ft-lb in 7 ft-lb increments.

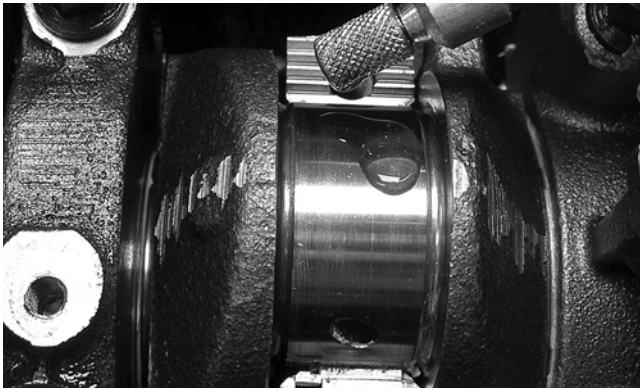

DE437

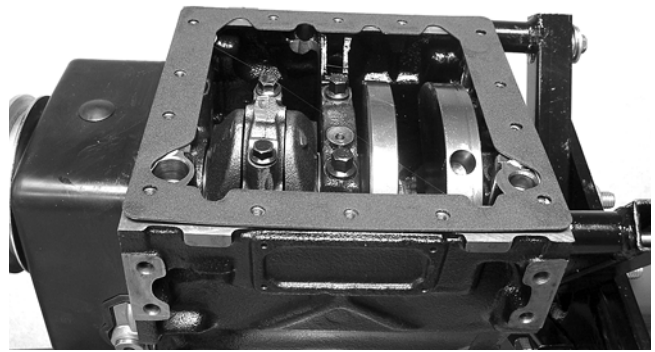

DE410

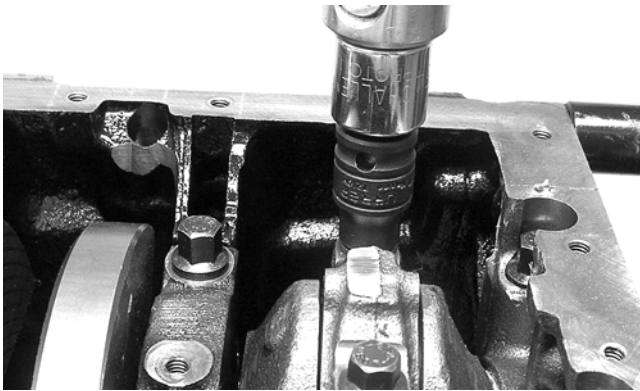

DE439

22. Repeat steps 15-21 for the second piston.
23. Install the oil pump (see Fuel/Lubrication/Cooling).
24. Install the water pump (see Fuel/Lubrication/Cooling).
25. Install the cylinder head (see Top-Side Components in this section).
26. Trim off the excessive material and cover the ends of the lateral seals with RTV Silicone; then place a new oil pan gasket in place making sure to properly align the gasket with the oil sump and return galley.

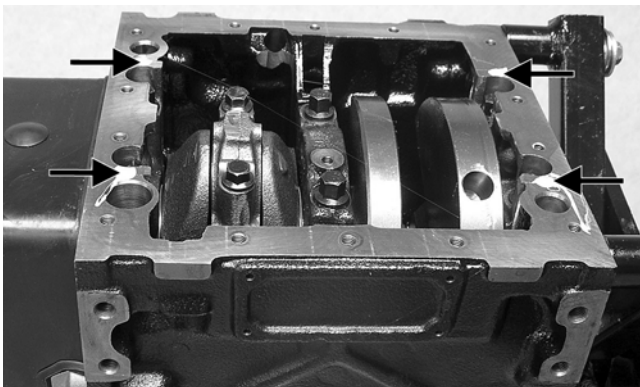

DE440B

27. Install new O-rings on the oil sump and return pipes; then apply oil-soluble grease on the O-rings and place the oil pan into position.

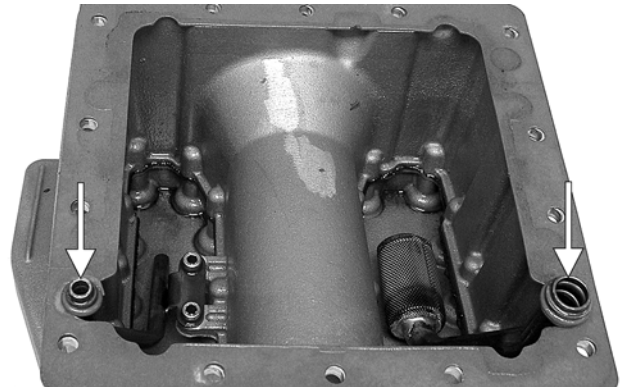

DE596A

28. Secure the oil pan with the Allen-head cap screws and the two hollow studs and spacers making sure to install the two hollow studs at the outside corners on the crankshaft pulley side; then using a crisscross pattern, tighten to 7 ft-lb.



DE442A

29. If the oil pan cover was removed, place two new gaskets onto the oil pan; then install the oil pan cover and secure with the Allen-head cap screws. Tighten in a crisscross pattern to 7 ft-lb.



DE442A

30. Install the coolant bypass hose and secure with the support clamps and two Allen-head cap screws to the two hollow studs; then secure the bypass hose to the fittings with the hose clamps. Tighten securely.
31. Install a new crankshaft seal in the rear engine seal flange; then apply a small amount of RTV Silicone to the extended ends of the lateral seals.

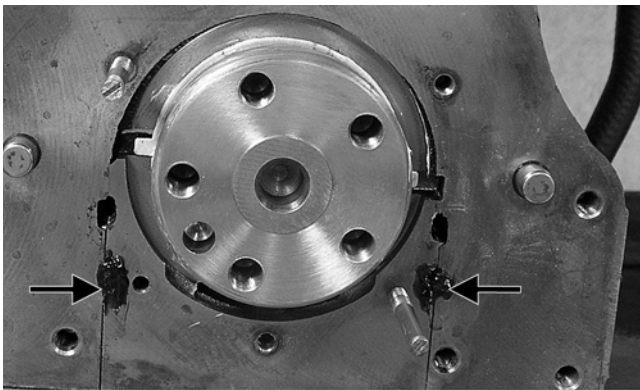

DE497A

32. Apply a liberal coat of oil-soluble grease to the lips of the oil seal and using a new gasket, carefully install the seal/flange assembly over the crankshaft being careful not to nick or cut the seal lips.

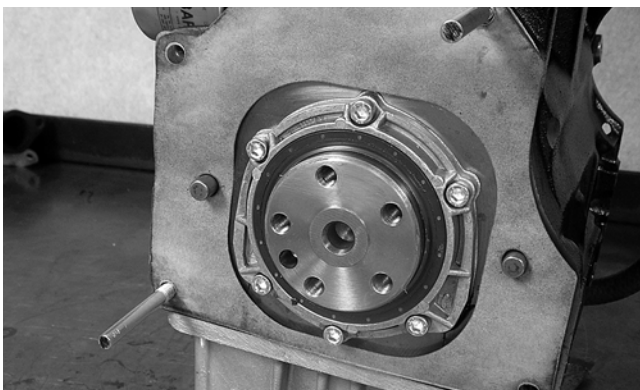

DE502

33. Secure with the existing hardware and tighten to 9 ft-lb.

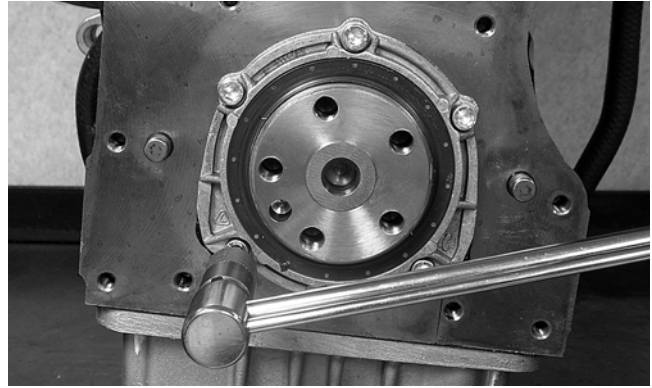

DE496

34. The engine is now assembled and ready for connection to the transmission/secondary transmission.
35. Install the engine/transmission assembly (see Installing Engine/Transmission in this section).

Installing Engine/ Transmission

■NOTE: Arctic Cat recommends that new gaskets and O-rings be installed whenever servicing the ATV.

■NOTE: If the engine/transmission was removed as an assembly, proceed to Engine/Transmission in this sub-section. If only the transmission was removed, use the following procedure to install.

TRANSMISSION

1. If the V-belt housing was removed from the crankcase, support the engine on blocks and using a new gasket, install the V-belt housing and tighten the mounting cap screws to 25 ft-lb.

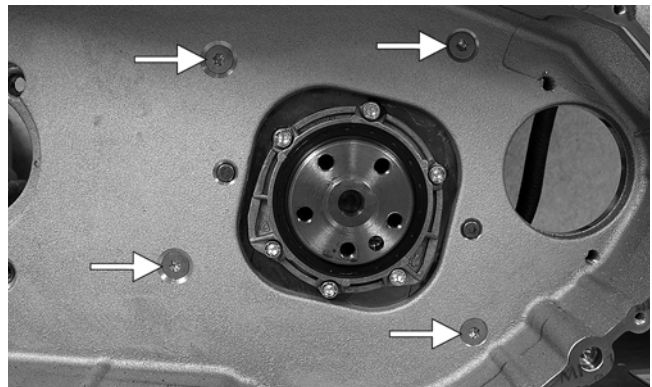

DE114A

2. Using a new gasket, install the transmission into the V-belt housing and secure with five cap screws. Do not tighten at this time.

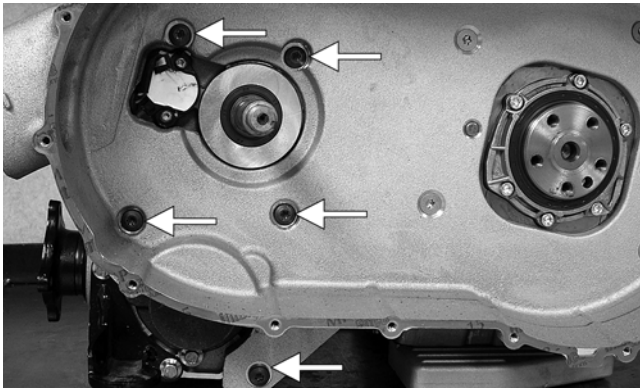

DE113A

3. Install the engine-to-transmission mounting plate and cap screws; then tighten the cap screws from step 2 and from this step to 35 ft-lb.

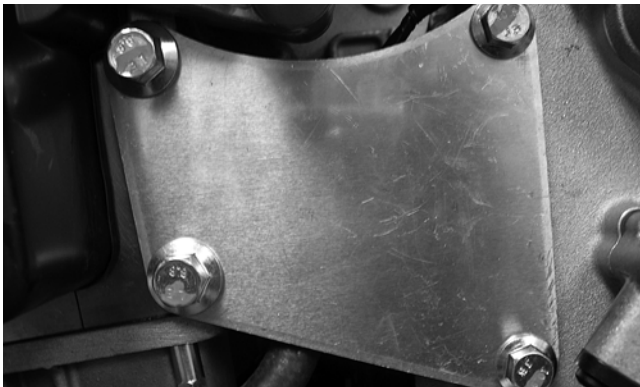

DE487

4. Install the PTO/flywheel onto the crankshaft and secure with five cap screws. Tighten to 40 ft-lb.

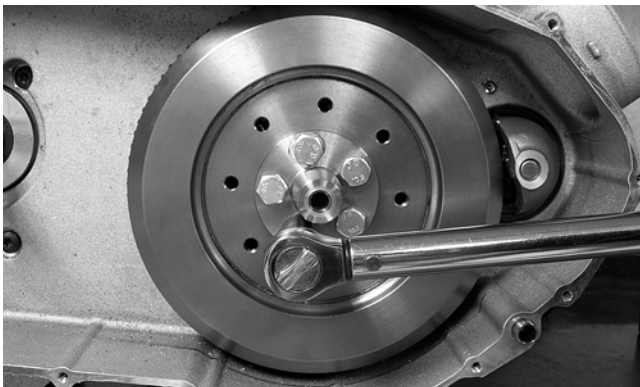

DE476

5. Install the fixed drive face onto the PTO shaft; then loop the drive belt around the driven pulley and install onto the input shaft by looping the belt over the fixed drive clutch hub. Make sure to orient the belt correctly if directional arrows are present.

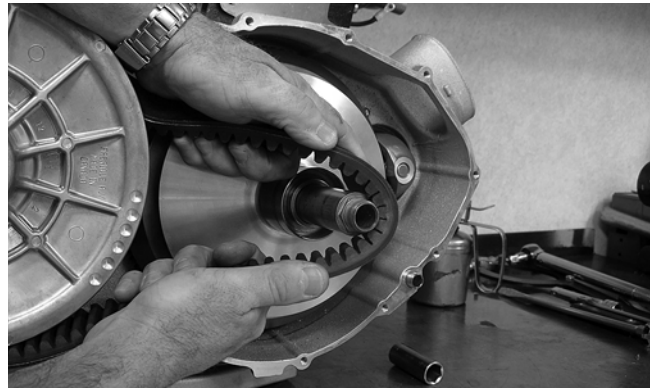

DE479

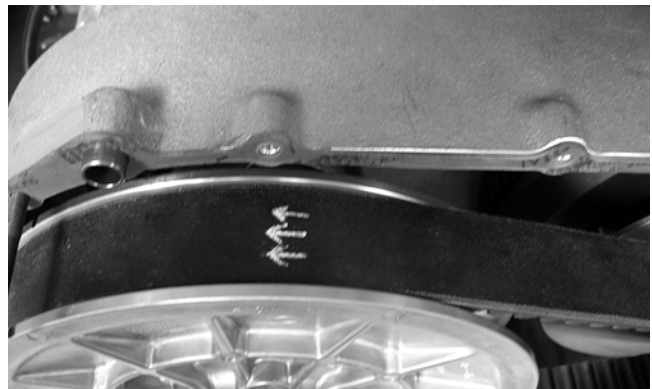

DE488

6. Secure the driven pulley with a flat washer and nut (threads coated with green Loctite #609); then tighten the nut to 125 ft-lb.

■NOTE: If using a new nut, ensure any bare threads are coated with green Loctite #609.

7. Install the movable drive clutch face and V-belt cover (see Checking/Replacing V-Belt in Periodic Maintenance/Tune-Up).

ENGINE/TRANSMISSION

1. Attach a suitable lift and place the engine/transmission assembly into the frame from the left side tilting the engine forward sufficiently to clear the frame tube.

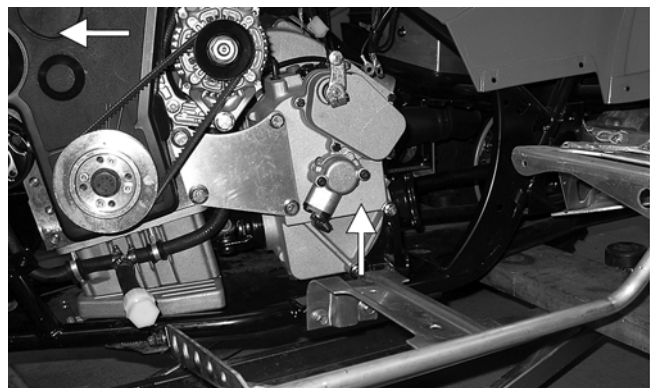

DE084A

2. Maneuver the engine/transmission into position in the frame; then install the front propeller shaft into the front output yoke.

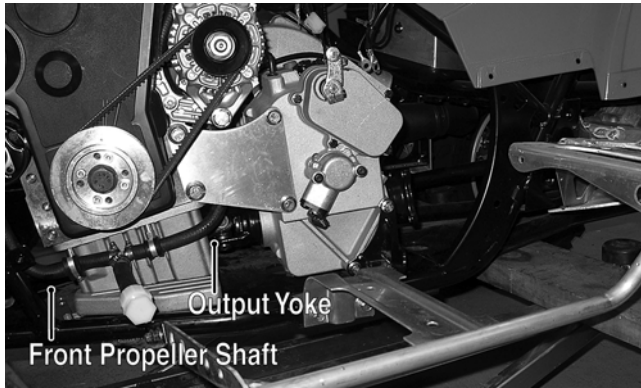

DE084B

3. Align and connect the rear propeller shaft to the rear output drive flange and secure with four cap screws; then align and secure the front propeller shaft to the differential input flange.

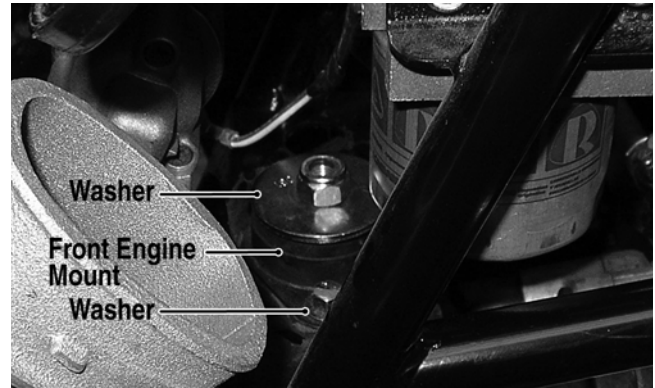

DE087A

6. Install the cap screws, washers, and nuts in the left rear, right rear, and upper right engine mounts.

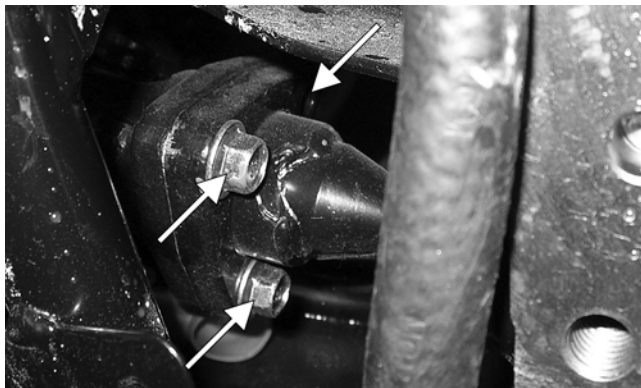

DE081A

4. Install the front mounting bracket onto the engine and secure with four cap screws. Tighten to 20 ft-lb.

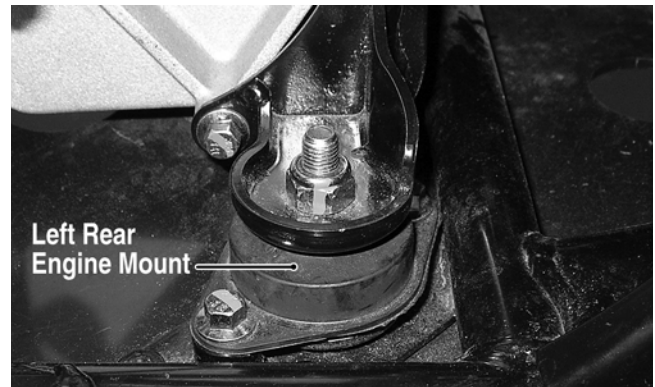

DE085A



DE090A

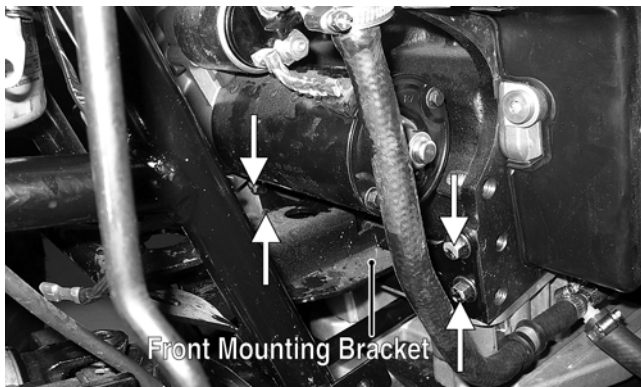

DE083A

5. Raise the front of the engine and install a cap screw, two flat washers, and a nut securing the front mounting bracket to the front engine mount. Do not tighten at this time.



DE088A

7. Tighten lower engine mounting cap screws and nuts to 20 ft-lb and upper engine mount to 35 ft-lb.

8. Install the transmission level stick mount using a new O-ring; then connect the throttle cable and thread the throttle cable housing into the bracket.

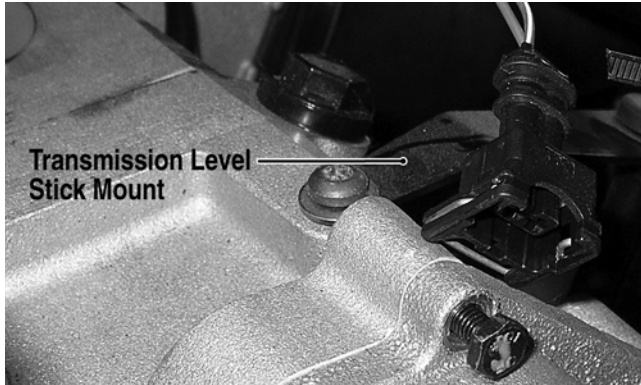

DE091A

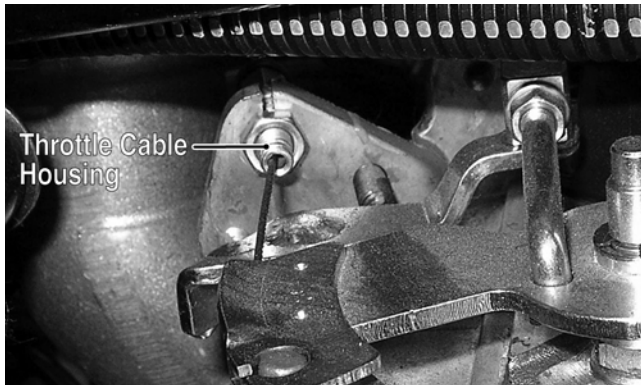

DE080A

9. If removed, install the fuel filter bracket onto the frame and tighten the mounting hardware securely.



DE032

10. Install the exhaust pipe and gasket and secure with two copper nuts. Do not tighten the nuts at this time.

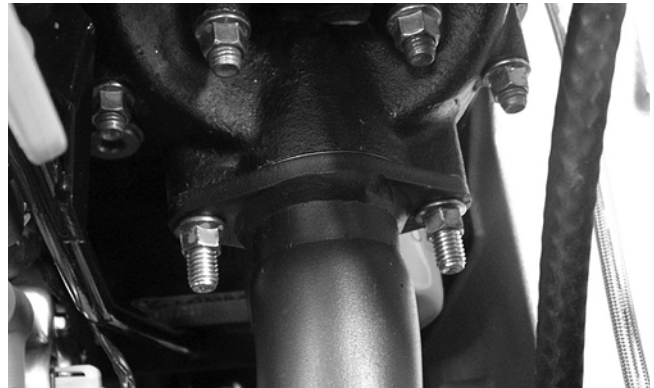

DE587

11. Install the muffler and secure to the exhaust pipe with two springs making sure the grafoil seal is in place; then tighten the exhaust pipe nuts to 14 ft-lb.

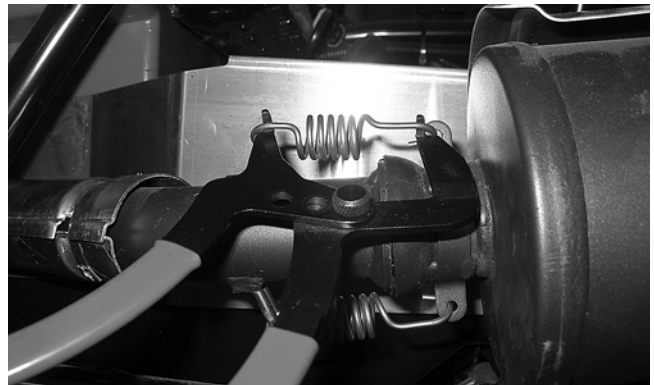

DE586

12. Connect the wiring connectors to the temperature sensor, oil pressure sensor, gear position switch connector, and voltage regulator; then connect the starter solenoid, glow plug power wire, and alternator positive wire.

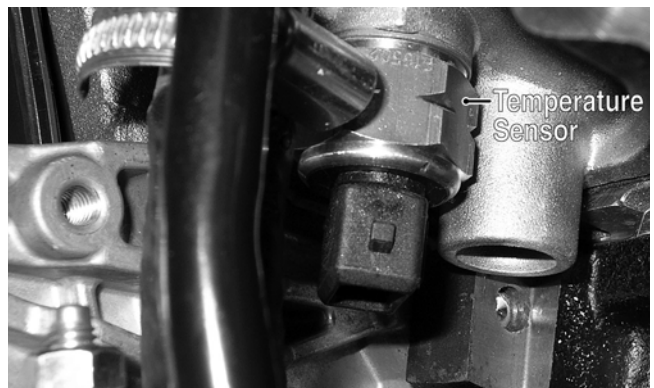

DE104A

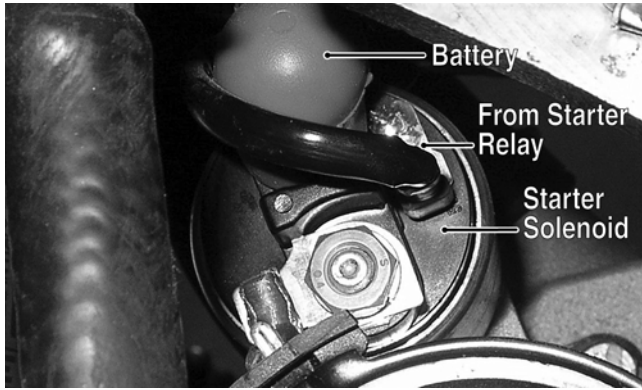

DE067A

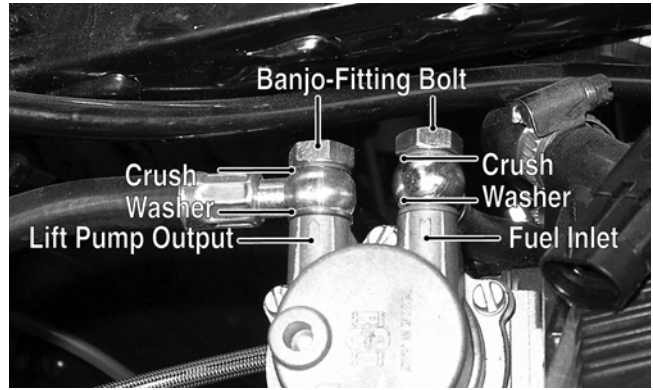

DE078B

15. Install the V-belt cooling fan assembly; then install the V-belt cooling boots to the V-belt housing.

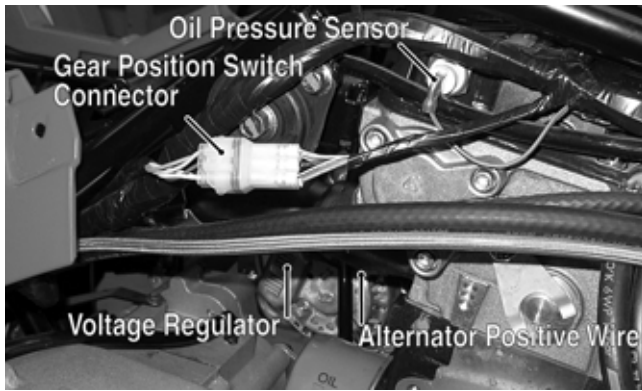

DE077C

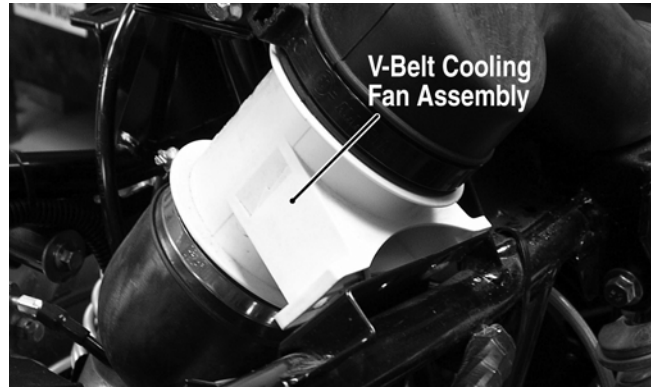

DE076A

16. Connect the V-belt cooling fan connector.



DE494A



DE518A

13. Connect the fuel supply and return hoses and secure with the hose clamps.

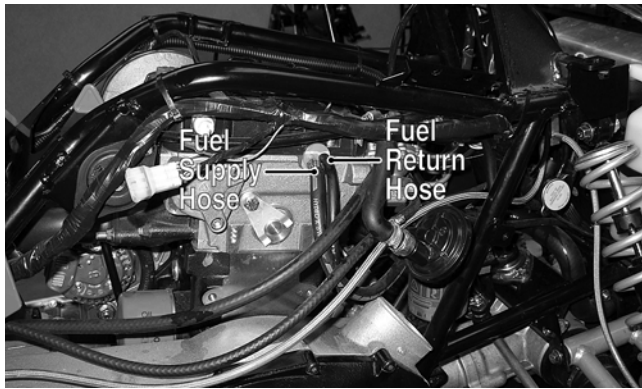

DE065A

17. Install the air filter assembly and secure with four cap screws; then connect all hoses and secure with hose clamps. Tighten all hardware securely.

14. Using new crush washers, connect the fuel inlet and lift pump outlet banjo-fitting bolts to the lift pump and tighten the banjo-fitting bolts securely.



DE074A

18. Install the coolant filler neck on the thermostat housing and tighten the hose clamp securely; then install the upper radiator hose. Tighten all hose clamps securely.

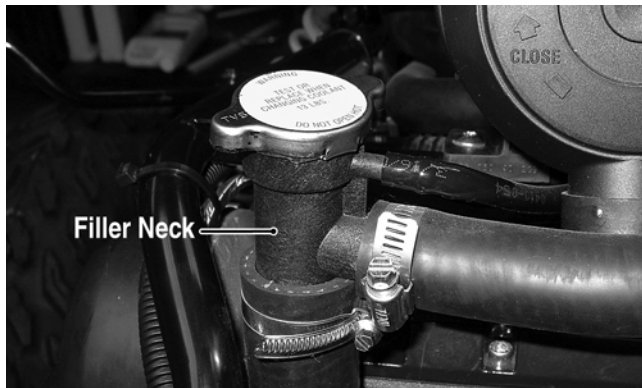

19. Install the air diverter and tighten the clamps securely.
20. Secure the engine and main harness grounds to the transmission at the location noted during removal; then connect the speed sensor connector to the speed sensor.

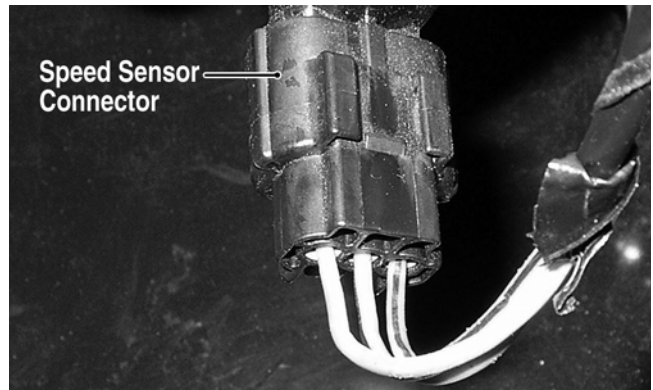

21. Connect the shift linkage to the transmission shift arm and secure with the E-clip.

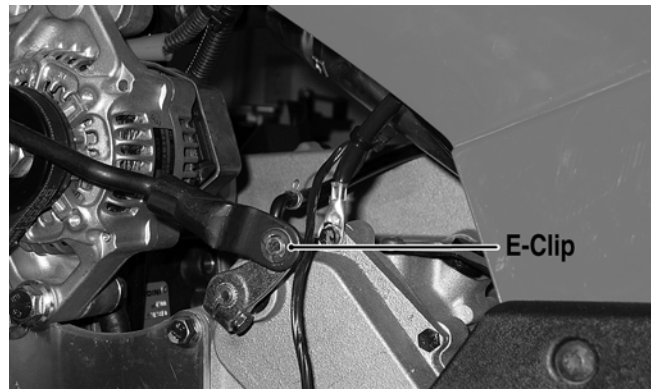

22. Install the front body panel and front rack; then install the left and right footrests (see Steering/Frame).
23. Pour the recommended coolant, engine oil, and transmission lubricant into the respective filler necks (see Periodic Maintenance/Tune-Up).
24. Install the battery and connect the positive battery cable; then connect the negative cable.
25. Install the seat making sure it locks securely in place.

Troubleshooting

Problem: Engine will not start or is hard to start (White smoke present)	
Condition	Remedy
<ol style="list-style-type: none"> 1. Glow plugs not heating 2. Glow plug heating insufficient 	<ol style="list-style-type: none"> 1. Check and troubleshoot glow plugs 2. Recycle glow plugs
Problem: Engine will not start or is hard to start - smoke present (Compression too low)	
Condition	Remedy
<ol style="list-style-type: none"> 1. Valve clearance out of adjustment 2. Valve guides worn - seated poorly 3. Valves mistimed 4. Piston rings worn excessively 5. Cylinder bore worn 6. Starter motor cranks too slowly - does not turn 	<ol style="list-style-type: none"> 1. Adjust clearance 2. Repair - replace guides 3. Retime valves 4. Replace rings 5. Replace - rebore engine block 6. See Electrical System - Troubleshooting
Problem: Engine will not start or is hard to start - smoke not present (No fuel reaching the fuel injector)	
Condition	Remedy
<ol style="list-style-type: none"> 1. Fuel tank vent hose obstructed 2. Fuel hose obstructed 3. Fuel filter obstructed 4. Fuel lift pump defective 5. Fuel solenoid valve not opening 	<ol style="list-style-type: none"> 1. Clean vent hose 2. Clean - replace hose 3. Replace fuel filter 4. Replace pump 5. See Electrical System - Fuel Solenoid
Problem: Engine stalls easily	
Condition	Remedy
<ol style="list-style-type: none"> 1. Valve clearance out of adjustment 	<ol style="list-style-type: none"> 1. Adjust clearance
Problem: Engine noisy (Excessive valve chatter)	
Condition	Remedy
<ol style="list-style-type: none"> 1. Valve clearance too large 2. Valve spring(s) weak - broken 3. Rocker arm - rocker arm shaft worn 4. Camshaft worn 5. Cam followers worn 	<ol style="list-style-type: none"> 1. Adjust clearance 2. Replace spring(s) 3. Replace arm - shaft 4. Replace camshaft 5. Replace cam followers
Problem: Engine noisy (Noise seems to come from piston)	
Condition	Remedy
<ol style="list-style-type: none"> 1. Piston - cylinder worn 2. Combustion chamber carbon buildup 3. Piston pin - piston pin bore worn 4. Piston rings - ring groove(s) worn 	<ol style="list-style-type: none"> 1. Replace - service piston - engine block 2. Clean chamber 3. Replace - service pin - bore 4. Replace rings - piston
Problem: Engine noisy (Noise seems to come from crankshaft)	
Condition	Remedy
<ol style="list-style-type: none"> 1. Bearings worn - burned 	<ol style="list-style-type: none"> 1. Replace bearings and/or crankshaft
Problem: Gears noisy (Noise seems to come from transmission)	
Condition	Remedy
<ol style="list-style-type: none"> 1. Gears worn - chipped 2. Splines worn 3. Primary gears worn - chipped 4. Bearings worn 5. Bushing worn 	<ol style="list-style-type: none"> 1. Replace gears 2. Replace shaft(s) 3. Replace gears 4. Replace bearings 5. Replace bushing
Problem: Gears noisy (Noise seems to come from secondary bevel gear and final driven shaft)	
Condition	Remedy
<ol style="list-style-type: none"> 1. Drive - driven bevel gears damaged - worn 2. Backlash excessive 3. Tooth contact improper 4. Bearing damaged 5. Gears worn - chipped 6. Splines worn 	<ol style="list-style-type: none"> 1. Replace gears 2. Adjust backlash 3. Adjust contact 4. Replace bearing 5. Replace gears 6. Replace shaft(s)

Problem: Engine idles poorly	
Condition	Remedy
<ol style="list-style-type: none"> 1. Valve clearance out of adjustment 2. Valve seating poor 3. Valve guides defective 4. Rocker arms - arm shaft worn 5. Fuel injector obstructed 6. Injector timing incorrect 	<ol style="list-style-type: none"> 1. Adjust clearance 2. Replace - service seats - valves 3. Replace guides 4. Replace arms - shafts 5. Replace fuel injector 6. Time injectors
Problem: Engine runs poorly at high speed	
Condition	Remedy
<ol style="list-style-type: none"> 1. Valve springs weak 2. Valves mistimed 3. Cams - rocker arms worn 4. Air cleaner element obstructed 5. Fuel hose obstructed 6. Lift pump defective 7. Fuel filter plugged 	<ol style="list-style-type: none"> 1. Replace springs 2. Retime valves 3. Replace cams - arms 4. Clean - replace element 5. Clean - replace hose 6. Replace pump 7. Replace filter
Problem: Exhaust smoke dirty or heavy	
Condition	Remedy
<ol style="list-style-type: none"> 1. Oil (in the engine) overfilled - contaminated 2. Piston rings - cylinder worn 3. Valve guides worn 4. Cylinder wall scored - scuffed 5. Valve stems worn 6. Stem seals defective 7. Air cleaner element obstructed 	<ol style="list-style-type: none"> 1. Drain excess oil - replace oil 2. Replace - service rings - cylinder 3. Replace guides 4. Replace - bore engine block 5. Replace valves 6. Replace seals 7. Clean - replace element
Problem: Engine lacks power	
Condition	Remedy
<ol style="list-style-type: none"> 1. Valve clearance incorrect 2. Valve springs weak 3. Valves mistimed 4. Piston ring(s) - cylinder worn 5. Valve seating poor 6. Rocker arms - shafts worn 7. Air cleaner element obstructed 8. Oil (in the engine) overfilled - contaminated 9. Injector timing incorrect 10. Fuel filter restricted 	<ol style="list-style-type: none"> 1. Adjust clearance 2. Replace springs 3. Retime valves 4. Replace - service rings - engine block 5. Repair seats 6. Replace arms - shafts 7. Clean element 8. Drain excess oil - change oil 9. Time injectors 10. Replace fuel filter
Problem: Engine overheats	
Condition	Remedy
<ol style="list-style-type: none"> 1. Air filter restricted 2. Oil low 3. Fuel incorrect 4. Oil pump defective 5. Oil circuit obstructed 6. Coolant level low 7. Fan malfunctioning 8. Fan switch malfunctioning 9. Thermostat stuck - closed 10. Radiator hoses - cap damaged - obstructed 	<ol style="list-style-type: none"> 1. Clean - replace air filter 2. Add oil 3. Drain - replace fuel 4. Replace pump 5. Clean circuit 6. Fill - examine system for leaks 7. Check fan fuse - replace fan 8. Replace fan switch 9. Replace thermostat 10. Clear obstruction - replace hoses

Fuel/Lubrication/Cooling

■NOTE: Some photographs and illustrations used in this section are used for clarity purposes only and are not designed to depict actual conditions.

SPECIAL TOOLS

A number of special tools must be available to the technician when performing service procedures in this section.

Description	p/n
Tachometer	0644-275
Oil Pressure Test Kit	0644-495

■NOTE: Special tools are available from the Arctic Cat Service Parts Department.

Diesel Fuel Injection System

The diesel engine in this Arctic Cat ATV is a “compression ignition” engine. Extremely high pressure in the combustion chamber raises air temperature high enough to cause ignition of the fuel upon injection into the combustion chamber. No spark is present or required for ignition.

In this style of engine, diesel fuel is drawn from the fuel tank by a low pressure lift pump. From the lift pump, fuel is pumped through the fuel filter/fuel shut-off and delivered to the fuel rail. Low pressure fuel at 0.42-0.56 kg-cm² (6-8 psi) flows to the unit injectors (high pressure fuel pump/fuel injector) where the fuel pump, driven by a special lobe on the camshaft, increases the fuel pressure to 143-153 kg-cm² (2030-2175 psi). At this point, the fuel is atomized by the fuel injector nozzle as it enters the combustion chamber.

Fuel in excess of the amount required for any particular power setting is directed back into the fuel return side of the fuel rail and routed back to the fuel filter head where it either recirculates or is returned to the fuel tank via the fuel return hose.

Fuel flow is shut off when the ignition switch is turned to the OFF position. A fuel solenoid valve is located on the fuel filter head and opens the valve whenever a 12 DC volt current is applied to the solenoid.

Lift Pump

REMOVING

1. Remove the banjo-fitting bolts securing the fuel hoses to the lift pump; then remove the two nuts securing the lift pump to the cylinder head. Account for four crush washers, an O-ring, and two flat washers.

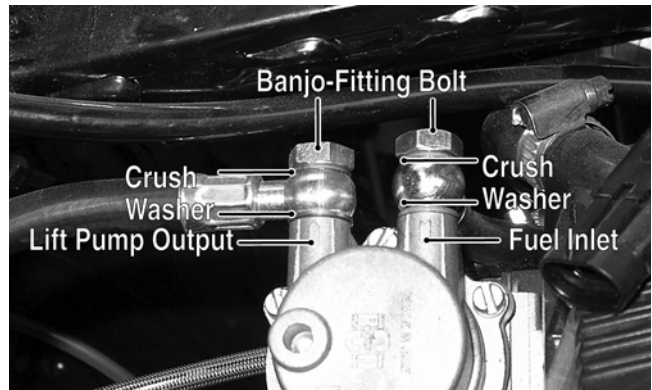

DE078B

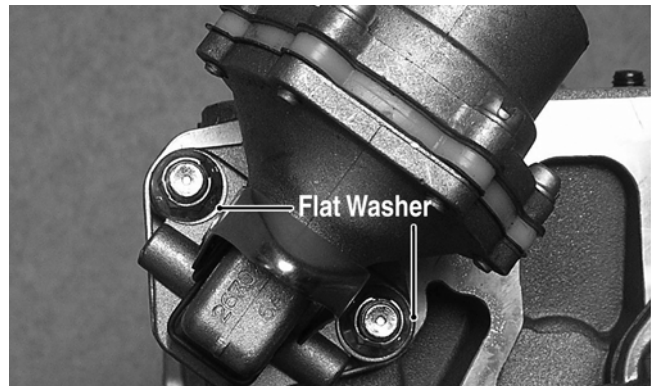

DE309A

2. While holding pressure against the lift pump push rod, rotate the engine until the push rod is fully retracted.

■NOTE: If pressure is not applied to the push rod while rotating the engine, the push rod may become dislodged from the eccentric ring requiring valve cover removal to relocate.

INSTALLING

1. Using a new O-ring, place the fuel pump onto the cylinder head and secure with the existing hardware. Tighten the nuts alternately until the fuel pump is seated against the head; then tighten securely.



DE530

2. Connect the fuel inlet and lift pump outlet hoses to the fuel lift pump using new crush washers and secure with the banjo-fitting bolts. Tighten securely.

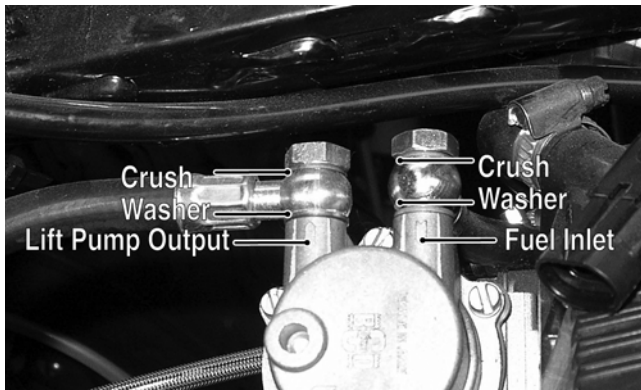

DE078A

Unit Injectors

To service the unit injectors, see Top-Side Components in Engine/Transmission.

Injector Timing

■NOTE: For injector timing instructions, see Top-Side Components in Engine/Transmission.

Fuel Filter

To replace the fuel filter, see Periodic Maintenance/Tune-Up.

Fuel Solenoid Assembly

■NOTE: After troubleshooting the fuel solenoid (see Electrical System) if it is determined that replacement is necessary, use the following procedure.

REMOVING

1. Remove the right-front inner splash panel; then remove the V-belt cooling boot from the V-belt housing.



DE061A

2. Locate the fuel solenoid mounted on top of the fuel filter head; then disconnect the spade connector from the solenoid.

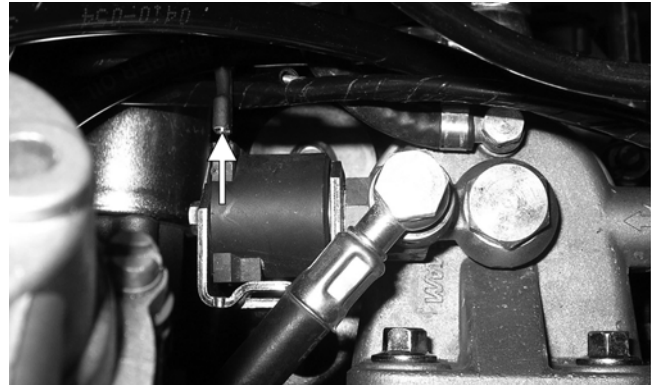

DE647B

3. Remove the banjo-fitting bolts (A) and (B) and remove the fuel solenoid. Account for four crush washers.

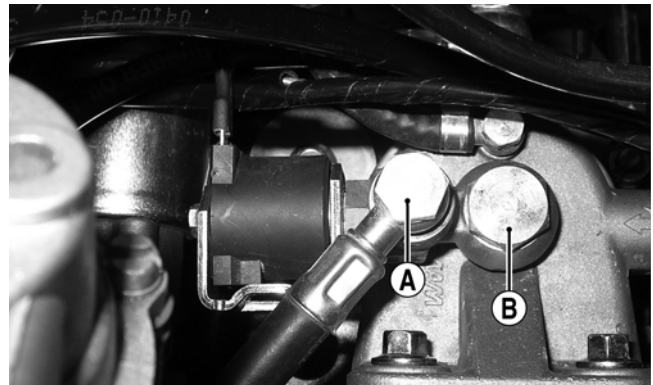

DE647A

INSTALLING

1. Using new crush washers, secure the fuel solenoid to the filter housing with banjo-fitting bolt (B) and tighten securely.

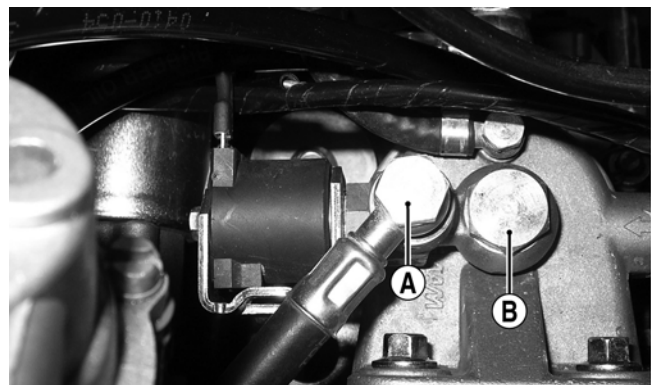

DE647A

2. Secure the fuel hose to the fuel solenoid with new crush washers and banjo-fitting bolt (A).
3. Connect the spade connector to the solenoid.

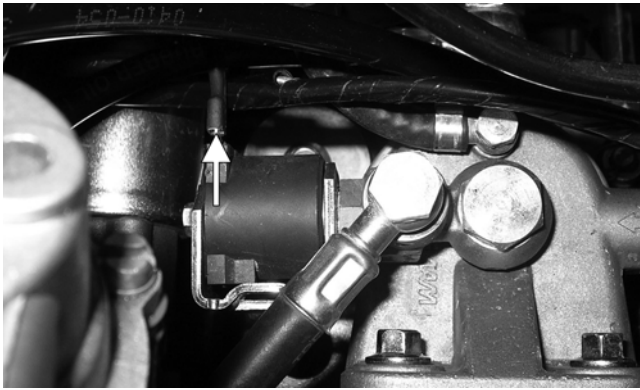

DE647B

4. Bleed any air from the system by turning the ignition switch to the ON position and pumping the manual primer pump until resistance is felt.

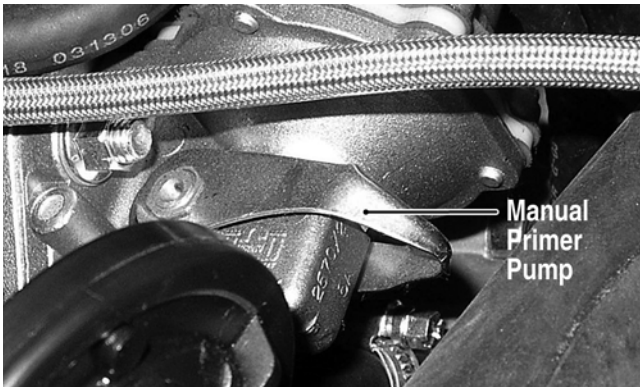

DE031A

5. Start the engine and check for leaks; then shut off the engine and install the inner fender splash panel, right-side engine cover, and seat. Make sure the seat latches securely.

Fuel Tank

WARNING

Whenever any maintenance or inspection is made on the fuel system during which there may be fuel leakage, there should be no welding, smoking, open flames, etc., in the area.

REMOVING

■NOTE: Fuel tank removal should only be necessary if the tank is leaking fuel or has been contaminated with water, dirt, or inadvertently filled with gasoline.

1. Remove the seat.
2. Remove the rear rack and fenders (see Steering/Frame).
3. Disconnect the hose from the fuel tank to the lift pump; then disconnect the vent hose and fuel return hose.
4. Remove the cap screws securing the gas tank to the frame.
5. Disconnect the fuel gauge connector; then remove the fuel tank.

CLEANING AND INSPECTING

■NOTE: Whenever a part is worn excessively, cracked, or damaged in any way, replacement is necessary.

1. Remove the fuel level sensor and fuel pick-up screen. Account for a seal.
2. Completely drain all contaminated fuel from the fuel tank; then thoroughly wash the tank out with hot, soapy water.
3. Dry the tank interior with compressed air.

■NOTE: Repeat steps 2 and 3 until all contaminants are removed.

4. Back-flush the fuel screen with hot, soapy water and dry with compressed air.

■NOTE: If any “pin-holes” are noted in the fuel screen, replace the fuel level sensor assembly.

5. Inspect the tank cap and filler neck for chipped or broken threads.
6. Inspect the fuel tank mountings for security, signs of cracking, or wearing through the tank.
7. Inspect all fuel and vent hoses for cracks, softening, or deterioration. Replace as required.

INSTALLING

1. Place the fuel tank into position in the frame; then install the cap screws. Tighten securely.
2. Connect the fuel hose from the lift pump; then connect the fuel gauge connector.
3. Install the vent hose and fuel return hose; then fill the fuel tank with clean diesel fuel.
4. Replace the fuel filter (see Periodic Maintenance/Tune-Up).
5. Pump the manual primer pump 12-20 strokes; then start the engine and inspect for leakage.
6. Install the rear fenders and rack (see Steering/Frame); then install the seat making sure it latches securely.

Fuel/Vent Hoses

Replace the fuel hoses every two years. Damage from aging may not always be visible. Do not bend or obstruct the routing of the vent hose or fuel return hose.

Oil Filter/Oil Pump

■NOTE: Whenever internal engine components wear excessively or break and whenever oil is contaminated, the oil pump should be replaced. The oil pump is not a serviceable component.

Testing Oil Pump Pressure

■NOTE: The engine must be warmed up to the specified temperature for this test (see Engine/Transmission - Specifications).

1. Connect the Tachometer to the engine.
2. Disconnect the oil pressure switch connector; then connect the Oil Pressure Test Kit to the oil pressure switch port.



DE077B

■NOTE: Some oil seepage may occur when installing the oil pressure gauge. Wipe up oil residue with a cloth.

3. Start the engine and run at the recommended RPM. The oil pressure gauge must read as specified (see Engine/Transmission - Specifications).

■NOTE: If oil pressure is lower than specified, check for an oil leak, damaged oil seal, defective oil pump, or oil cooler.

■NOTE: If oil pressure is higher than specified, check for too heavy engine oil weight (see General Information - Fuel-Oil-Lubricant), clogged oil passage, clogged oil filter, or improper installation of the oil filter.

Liquid Cooling System

To check the cooling system, see Periodic Maintenance/Tune-Up.

DRAINING COOLANT

The cooling system does not have a drain; therefore, coolant must be removed using the following procedure.

1. Using suitable in-line clamps, close off the lower radiator hose and the coolant bypass hose next to the water pump.

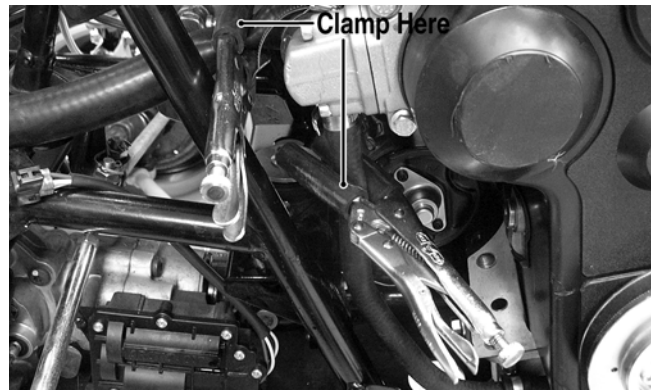

DE510A

2. Place a suitable drain pan with a capacity of at least 4 l (4.2 U.S. qt) under the left front of the engine; then loosen the hose clamp on the coolant bypass hose.
3. Remove the hose and allow coolant to drain into the drain pan. A funnel or short hose can be used to direct coolant into the drain pan.
4. Install the coolant bypass hose and tighten the clamp securely; then remove the in-line clamps.

FILLING COOLANT

1. Elevate the rear of the ATV approximately 30 cm (12 in.) and secure in place using appropriate blocks.

CAUTION

Failure to elevate the rear of the ATV may result in air being trapped in the cooling system causing severe engine damage due to overheating.

2. Remove the cap from the filler neck (located under the service access cover) and slowly pour the recommended amount of coolant into the system.
3. Move the ATV outside or to a well-ventilated area and start the engine allowing it to run for several minutes; then remove the filler cap and check the coolant level. Add coolant as required until coolant is visible within one inch of the top of the filler neck.
4. Install the filler cap on the filler neck and tighten until the cap contacts the stop.

WARNING

Do not over-tighten coolant filler cap or excess pressure will build up in the cooling system causing cooling system damage and possible bodily harm.

Radiator

REMOVING

1. Drain the coolant at the engine.
2. Remove the front rack (see Steering/Frame).
3. Remove the front bumper and front fender panel (see Steering/Frame).
4. Remove the upper and lower coolant hoses.

5. Remove the cap screws and nuts securing the radiator to the frame.
6. Disconnect the fan wiring from the main wiring harness; then remove the radiator/fan assembly and account for the grommets and collars.
7. Remove the fan/fan shroud assembly from the radiator.

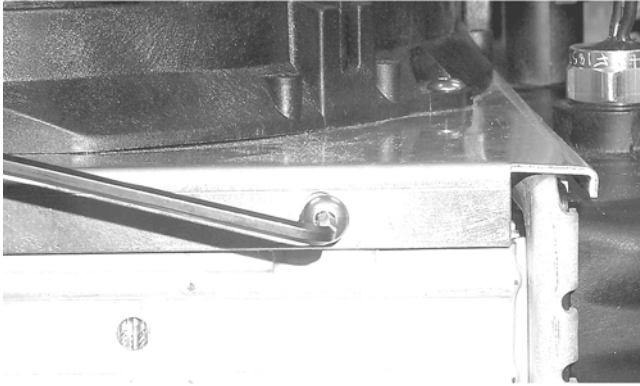

CC863

CLEANING AND INSPECTING

■NOTE: Whenever a part is worn excessively, cracked, or damaged in any way, replacement is necessary.

1. Flush the radiator with water to remove any contaminants.
2. Inspect the radiator for leaks and damage.
3. Inspect all hoses for cracks and deterioration.
4. Inspect all fasteners and grommets for damage or wear.

INSTALLING

1. Position the fan/fan shroud assembly on the radiator; then secure with existing hardware.
2. Place the radiator with grommets and collars into position on the frame; then install the cap screws and nuts. Tighten securely.
3. Install the upper and lower coolant hoses; then secure with hose clamps.



AF734D

4. Install the front bumper and front fender panel (see Steering/Frame).
5. Install the front rack (see Steering/Frame).

6. Fill the cooling system with the recommended amount of antifreeze. Check for leakage.
7. Connect the fan wiring to the main wiring harness.

Hoses/Thermostat

REMOVING

1. Drain approximately two quarts of coolant from the cooling system.
2. Remove the two cap screws securing the thermostat cover housing to the thermostat housing. Account for an O-ring and a thermostat.

INSPECTING

■NOTE: Whenever a part is worn excessively, cracked, or damaged in any way, replacement is necessary.

1. Inspect the thermostat for corrosion, wear, or spring damage.
2. Using the following procedure, inspect the thermostat for proper operation.
 - A. Suspend the thermostat in a container filled with water.
 - B. Heat the water and monitor the temperature with a thermometer.
 - C. The thermostat should start to open at 80° C (176° F) and be fully open at 95° C (203° F).
 - D. If the thermostat does not open or remains open, it must be replaced.
3. Inspect all coolant hoses, connections, and clamps for deterioration, cracks, and wear.

■NOTE: All coolant hoses and clamps should be replaced every four years or 4000 miles.

INSTALLING

1. Place the thermostat and O-ring into the thermostat housing; then secure the thermostat housing to the cylinder head with the two cap screws.
2. Install the crossover coolant hose onto the water pump and engine water inlet. Secure with the two hose clamps.
3. Slide the upper hose onto the thermostat housing and radiator. Secure with the two hose clamps.
4. Install the lower coolant hose onto the water pump housing and radiator. Secure with the two hose clamps.
5. Fill the cooling system with the recommended amount of antifreeze. Check for leakage.

Fan

REMOVING

1. Remove the radiator (see Radiator in this section).
2. Remove the fan assembly from the radiator.

INSTALLING

1. Position the fan assembly on the radiator; then secure with existing hardware.

■NOTE: The fan wiring must be in the upper-right position.

2. Install the radiator (see Radiator in this section).

Water Pump

■NOTE: The water pump is a non serviceable component and must be replaced as an assembly.

To replace the water pump, see Engine/Transmission - Left-Side Components.

Troubleshooting

Problem: Starting impaired	
Condition	Remedy
1. Fuel contaminated	1. Drain fuel tank and fill with clean fuel
Problem: Idling or low speed impaired	
Condition	Remedy
1. Fuel filter plugged	1. Replace fuel filter
Problem: Medium or high speed impaired	
Condition	Remedy
1. Governor spring broken 2. Fuel filter obstructed 3. Throttle cable out of adjustment	1. Replace speed governor spring 2. Replace filter 3. Adjust throttle cable

Electrical System

The electrical connections should be checked periodically for proper function. In case of an electrical failure, check fuses, connections (for tightness, corrosion, damage), and/or bulbs.

SPECIAL TOOLS

A special tool must be available to the technician when servicing the electrical system.

Description	p/n
Fluke Model 77 Multimeter	0644-559

■NOTE: Special tools are available from the Arctic Cat Service Parts Department.

Battery

The battery is located in a compartment in front of the left-rear wheel under the driver seat.

■NOTE: To access the battery box, the left-rear fender splash panel must be removed.

After being in service, batteries require regular cleaning and recharging in order to deliver peak performance and maximum service life. The following procedures are recommended for cleaning and maintaining lead-acid batteries. Always read and follow instructions provided with battery chargers and battery products.

■NOTE: Refer to all warnings and cautions provided with the battery or battery maintainer/charger.

Loss of battery charge may be caused by ambient temperature, ignition OFF current draw, corroded terminals, self discharge, frequent start/stops, and short engine run times. Frequent winch usage, snowplowing, extended low RPM operation, short trips, and high amperage accessory usage are also reasons for battery discharge.

Maintenance Charging

■NOTE: Arctic Cat recommends the use of the CTEK Multi US 800 or the CTEK Multi US 3300 for battery maintenance charging. Maintenance charging is required on all batteries not used for more than two weeks or as required by battery drain.

1. When charging a battery in the vehicle, be sure the ignition switch is in the OFF position.

■NOTE: Be sure to maintain the fluid of the battery at the UPPER LEVEL. Use only distilled water when adding fluid to these batteries.

2. Clean the battery terminals with a solution of baking soda and water.
3. Be sure the charger and battery are in a well-ventilated area and ensure the battery charger cables will not contact any battery acid. Be sure the charger is unplugged from the 110-volt electrical outlet.

4. Connect the red terminal lead from the charger to the positive terminal of the battery; then connect the black terminal lead of the charger to the negative terminal of the battery.

■NOTE: Optional battery charging adapters are available from your authorized Arctic Cat dealer to connect directly to your vehicle from the recommended chargers to simplify the maintenance charging process. Check with your authorized Arctic Cat dealer for proper installation of these charging adapter connectors.

5. Plug the battery charger into a 110-volt electrical outlet.
6. If using the CTEK Multi US 800, there are no further buttons to push. If using the CTEK Multi US 3300, press the Mode button (A) at the left of the charger until the Maintenance Charge Icon (B) at the bottom illuminates. The Normal Charge Indicator (C) should illuminate on the upper portion of the battery charger.



800E

■NOTE: The maintainer/charger will charge the battery to 95% capacity at which time the Maintenance Charge Indicator (D) will illuminate and the maintainer/charger will change to pulse/float maintenance. If the battery falls below 12.9 DC volts, the charger will automatically start again at the first step of the charge sequence.

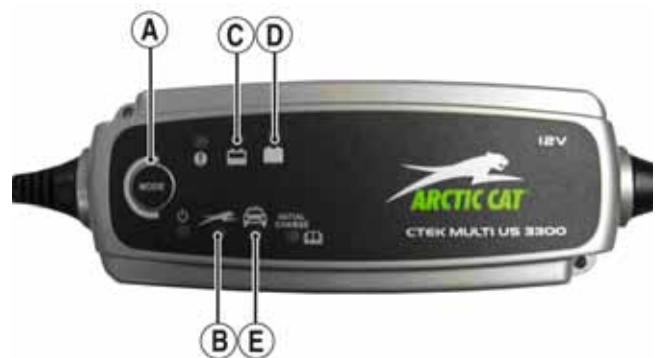

3300A

■NOTE: Not using a battery charger with the proper float maintenance will damage the battery if connected over extended periods.

Charging

■NOTE: Arctic Cat recommends the use of the CTEK Multi US 800 or the CTEK Multi US 3300 for battery maintenance charging.

1. Be sure the battery and terminals have been cleaned with a baking soda and water solution.
2. Be sure the charger and battery are in a well-ventilated area and ensure the battery charger cables will not contact any battery acid. Be sure the charger is unplugged from the 110-volt electrical outlet.
3. Connect the red terminal lead from the charger to the positive terminal of the battery; then connect the black terminal lead of the charger to the negative terminal of the battery.
4. Plug the charger into a 110-volt electrical outlet.
5. By pushing the Mode button (A) on the left side of the charger, select the Normal Charge Icon (E). The Normal Charge Indicator (C) should illuminate on the upper left portion of the charger.
6. The battery will charge to 95% of its capacity at which time the Maintenance Charge Indicator (D) will illuminate.

■NOTE: For optimal charge and performance, leave the charger connected to the battery for a minimum 1 hour after the Maintenance Charge Indicator (D) illuminates. If the battery becomes hot to the touch, stop charging. Resume after it has cooled.

7. Once the battery has reached full charge, unplug the charger from the 110-volt electrical outlet.

■NOTE: If, after charging, the battery does not perform to operator expectations, bring the battery to an authorized Arctic Cat dealer for further troubleshooting.

Testing Electrical Components

All of the electrical tests should be made using the Fluke Model 77 Multimeter. If any other type of meter is used, readings may vary due to internal circuitry. When troubleshooting a specific component, always verify first that the fuse(s) are good, that the bulb(s) are good, that the connections are clean and tight, that the battery is fully charged, and that all appropriate switches are activated.

■NOTE: For absolute accuracy, all tests should be made at room temperature of 68° F.

Switches

Each time the ATV is used, switches should be checked for proper operation. Use the following list for reference.

- A. Ignition switch — engine will start.

- B. Emergency stop switch — engine will stop.
- C. Reverse switch — reverse indicator light will illuminate.
- D. Hi/Lo switch — headlight beam bright and dim.
- E. Brake switches — rear brakelight will illuminate.

Accessory Receptacle/Connector

■NOTE: This test procedure is for either the receptacle or the connector.

VOLTAGE

1. Turn the ignition switch to the ON position; then set the meter selector to the DC Voltage position.
2. Connect the red tester lead to the red/white wire or the positive connector; then connect the black tester lead to ground.
3. The meter must show battery voltage.

■NOTE: If the meter shows no battery voltage, troubleshoot the battery, fuse, receptacle, connector, or the main wiring harness.

Brakelight Switch (Auxiliary)

The switch connector is the two-prong connector on the brake switch lead above the transmission.

■NOTE: The ignition switch must be in the ON position.

VOLTAGE (Wiring Harness Side)

1. Set the meter selector to the DC Voltage position.
2. Connect the red tester to the orange wire; then connect the black tester lead to ground.



AR627D

3. The meter must show battery voltage.

■NOTE: If the meter shows no battery voltage, troubleshoot the battery, fuse, switch, or the main wiring harness.

■NOTE: If the meter shows battery voltage, the main wiring harness is good; proceed to test the switch/component, the connector, and the switch wiring harness for resistance.

RESISTANCE (Switch Connector)

1. Set the meter selector to the OHMS position.
2. Connect the red tester lead to one black wire; then connect the black tester lead to the other black wire.

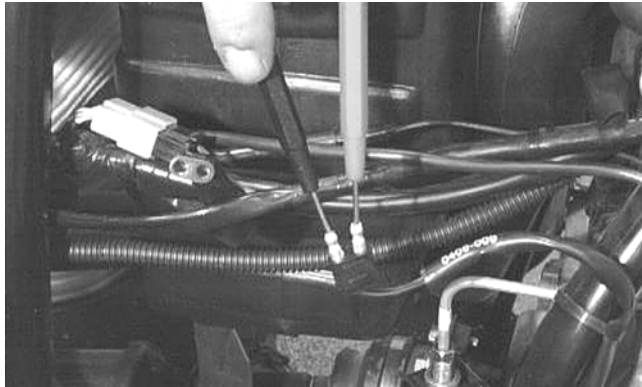

AR626D

3. When the brake pedal is depressed, the meter must show less than 1 ohm.

■NOTE: If the meter shows more than 1 ohm of resistance, replace the switch.

Brakelight Switch (Handlebar Control)

To access the connector, remove the access panel.

■NOTE: The ignition switch must be in the ON position.

VOLTAGE (Wiring Harness Connector)

1. Set the meter selector to the DC Voltage position.
2. Connect the red tester lead to the orange wire; then connect the black tester lead to ground.

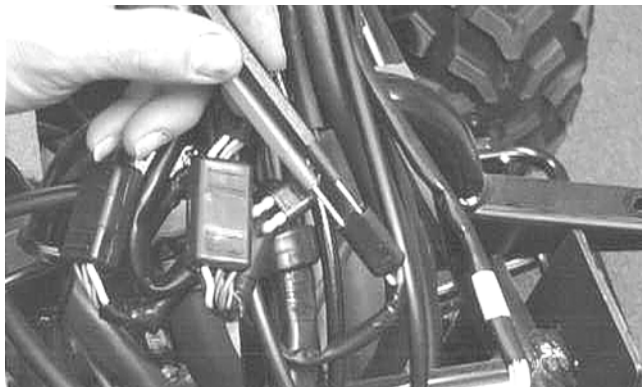

AR622D

3. The meter must show battery voltage.

■NOTE: If the meter shows no battery voltage, troubleshoot the battery, fuse, switch, or the main wiring harness.

■NOTE: If the meter shows battery voltage, the main wiring harness is good; proceed to test the switch/component, the connector, and the switch wiring harness for resistance.

RESISTANCE (Switch Connector)

■NOTE: The brake lever must be compressed for this test. Also, the ignition switch must be in the OFF position.

1. Set the meter selector to the OHMS position.
2. Connect the red tester lead to one black wire; then connect the black tester lead to the other black wire.



AR621D

3. When the lever is compressed, the meter must show less than 1 ohm.

■NOTE: If the meter shows more than 1 ohm of resistance, replace the switch.

Cooling Fan Switch

1. Connect the meter leads (selector in OHMS position) to the cooling fan switch terminals.
2. Suspend the switch and a thermometer in a container of water; then heat the water.

■NOTE: Neither the switch nor the thermometer should be allowed to touch the bottom of the container or inaccurate readings will occur. Use wire holders to suspend the switch and thermometer.

3. When the water temperature reaches approximately 93° C (199° F), the meter should read less than 1.0 ohm.
4. Allow the water to cool and when the temperature reaches approximately 87° C (189° F), the meter should read an open circuit.

Engine Coolant Temperature (ECT) Switch/Thermistor

The ECT switch/thermistor is a two-function device. One side is a normally open, temperature activated switch that closes when high coolant temperature is detected activating the high temperature circuit in the speedometer/LCD. The other side contains a temperature sensitive resistor (thermistor) that provides temperature information to the glow plug controller/relay. To test the ECT switch/thermistor, use the following procedure.

1. Suspend the ECT switch/thermistor and a thermometer in a container of cooking oil.

NOTE: Neither the ECT switch/thermistor nor the thermometer should be allowed to touch the bottom of the container or inaccurate readings will occur. Use wire holders to suspend the ECT switch/thermistor and thermometer.

2. Connect one meter lead to the base of the switch/thermistor and the other meter lead to the switch pin. With the meter in the OHMS position, the meter should read an open circuit.

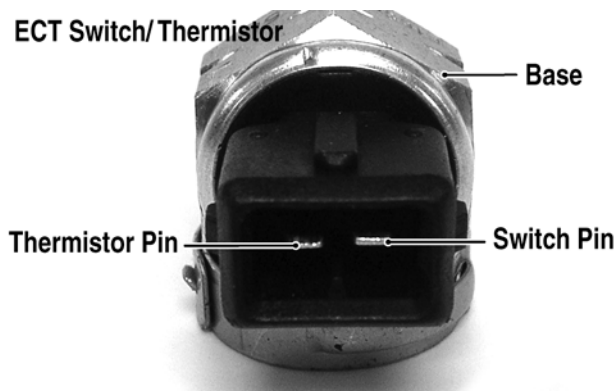

DE650A

3. Remove the meter lead from the switch pin and connect to the thermistor pin; then heat the oil and note the temperature and meter readings.
4. When the temperature reaches 20° C (68° F), the meter should read 1k ohms.
5. When the temperature reaches 40° C (104° F), the meter should read 460 ohms.
6. When the temperature reaches 50° C (122° F), the meter should read 320 ohms.
7. Remove the meter lead from the thermistor pin and connect to the switch pin; then continue to heat the oil.
8. When the temperature reaches approximately 110° C (230° F), the meter should read less than 1 ohm.

WARNING

Wear insulated gloves and safety glasses. Heated oil can cause severe burns.

Glow Plug Controller/Relay

The glow plug controller/relay is a plug-in device located under the seat. The glow plug controller/relay applies 12 DC volts to the glow plugs in the pre-combustion chambers to aid in cold starting. Heating time is determined by the ECT thermistor signal and will vary from 0 seconds (warm engine) to approximately 30 seconds (cold engine).

NOTE: The glow plug controller/relay is not a serviceable component. To test the controller/relay, use the following procedure.

1. Using an appropriate multimeter, select DC Volts and connect the black (-) tester lead to the black (85) wire and the red (+) tester lead to the red/orange (30) wire. The meter must read battery voltage. If no battery voltage is present, check the connection at the starter relay.
2. Connect the red tester lead to the white/blue (87) wire and momentarily turn the ignition switch to the ON position. The meter should read battery voltage for up to 30 seconds; then drop to zero.
3. Connect the red tester lead to the yellow/orange (L) wire and turn the ignition switch to the ON position. The meter should read battery voltage and the green glow plug indicator should illuminate for up to 30 seconds.
4. Turn the ignition switch off.
5. Turn the ignition switch to the ON position. Observe the glow plug indicator while momentarily “bumping” the starter button. The glow plug indicator should immediately extinguish.
6. If steps 2, 3, or 5 are not as specified, replace the glow plug controller/relay.
7. If the glow plugs remain on for more than 35 seconds, test the ECT switch/thermistor (thermistor side only).

NOTE: To test the glow plugs, use the following procedure.

1. Disconnect the white/blue glow plug power wire from the right-side glow plug; then disconnect the jumper wire running to the left-side glow plug.



DE494A

2. Select the OHMS position on a suitable tester; then connect one tester lead to a suitable ground and the other tester lead to the glow plug center connector. The meter must read less than 1 ohm.
3. If the meter reading is not as specified, replace the affected glow plug.

Fan Motor

The connector is the black two-prong one located behind the fan assembly.

■NOTE: The ignition switch must be in the ON position.

VOLTAGE (Main Harness Connector to Fan Motor)

1. Set the meter selector to the DC Voltage position.
2. Connect the red tester lead to the black/red wire; then connect the black tester lead to ground.
3. The meter must show battery voltage.

■NOTE: If the meter shows no battery voltage, troubleshoot the battery, fuse, motor, or the main wiring harness.

■NOTE: If the meter shows battery voltage, the main wiring harness is good. The connector should be checked for resistance.

RESISTANCE (Fan Motor Connector)

1. Set the meter selector to the OHMS position.
2. Connect the red tester lead to the blue wire; then connect the black tester lead to the black wire.



AR645D

3. The meter must show less than 1 ohm.

■NOTE: If the meter shows more than 1 ohm of resistance, troubleshoot or replace the switch/component, the connector, or the switch wiring harness.

■NOTE: To determine if the fan motor is good, connect the blue wire from the fan connector to a 12 volt DC power supply; then connect the black wire from the fan connector to ground. The fan should operate.

WARNING

Care should be taken to keep clear of the fan blades.

Fuse Block/Power Distribution Module

The fuses are located in a power distribution module under the seat. If there is any type of electrical system failure, always check the fuses first.

■NOTE: The ignition switch must be in the LIGHTS position.

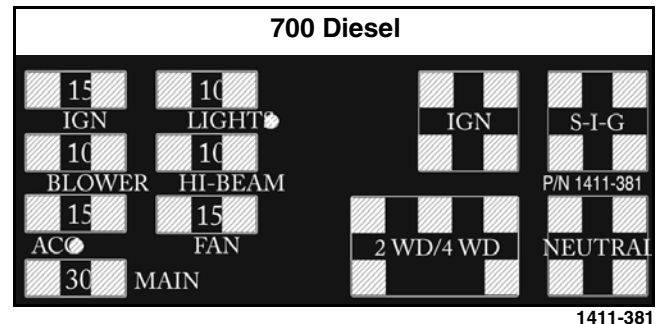

CAUTION

Always replace a blown fuse with a fuse of the same type and rating.

1. Remove all fuses from the distribution module.

■NOTE: To remove a fuse, compress the locking tabs on either side of the fuse case and lift out.

2. Set the meter selector to the DC Voltage position.
3. Connect the black tester lead to ground.
4. Using the red tester lead, contact each end of the fuse holder connector terminals individually.
5. The meter must show battery voltage from one side of the connector terminal ends.

■NOTE: Battery voltage will be indicated from only one side of the fuse holder connector terminal; the other side will show no voltage.

■NOTE: When testing the HI fuse holder, the headlight dimmer switch must be in the HI position; when testing the LIGHTS fuse holder, the headlight dimmer switch can be in either position.

■NOTE: If the meter shows no battery voltage, troubleshoot the battery, switches, distribution module, or the main wiring harness.

FUSES

1. Set the meter selector to the OHMS position.
2. Connect the red tester lead to one spade end of the fuse; then connect the black tester lead to the other spade end.

- The meter must show less than 1 ohm resistance. If the meter reads open, replace the fuse.

■NOTE: Make sure the fuses are returned to their proper position according to amperage. Refer to the fuse block cover for fuse placement.

RELAYS

The relays are identical plug-in type located on the power distribution module. Relay function can be checked by switching relay positions. The relays are interchangeable.

■NOTE: The module and wiring harness are not a serviceable component and must be replaced as an assembly.

Speed Sensor

■NOTE: Prior to testing the speed sensor, inspect the three-wire connector on the speed sensor for contamination, broken pins, and/or corrosion.

- Set the meter selector to the DC Voltage position.
- With appropriate needle adapters on the meter leads, connect the red tester lead to the voltage lead (V); then connect the black tester lead to the ground lead (G).

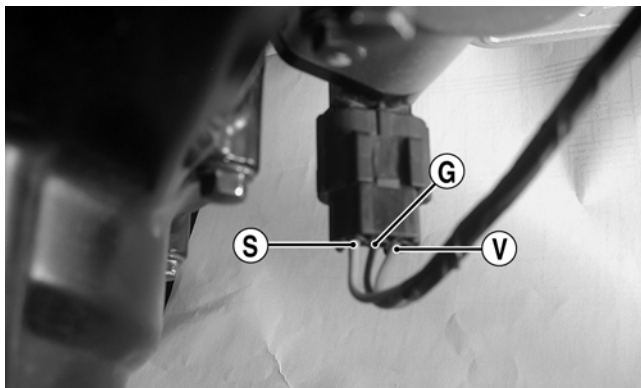

CD885A

- Turn the ignition switch to the ON position.
- The meter must show 6 DC volts.
- Leave the black tester lead connected; then connect the red tester lead to the signal lead (S) pin.
- Slowly move the ATV forward or backward; the meter must show 0 and 6 DC volts alternately.

■NOTE: If the sensor tests are within specifications, the speedometer must be replaced (see Controls/Indicators).

To replace a speed sensor, use the following procedure.

- Disconnect the three-wire connector from the speed sensor harness or from the speed sensor; then remove the Allen-head cap screw securing the sensor to the sensor housing.
- Remove the sensor from the sensor housing accounting for an O-ring.

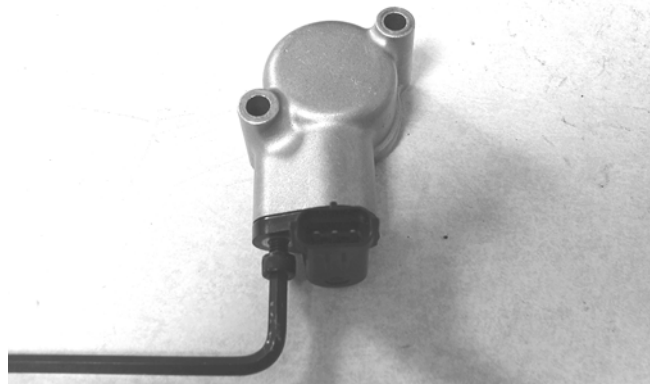

CD070

- Install the new speed sensor into the housing with new O-ring lightly coated with multi-purpose grease; then secure the sensor with the Allen-head cap screw (threads coated with blue Loctite #242). Tighten securely.

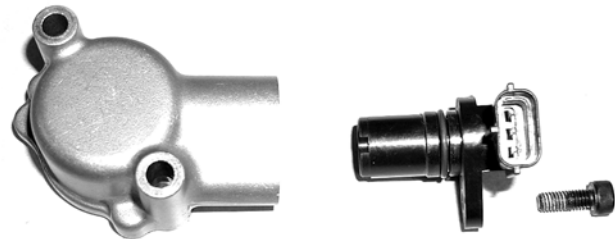

CD071

Ignition Switch

The connector is a four-wire one. To access the connector, the cover must be removed.

VOLTAGE

■NOTE: Perform this test on the lower side of the connector.

- Set the meter selector to the DC Voltage position.
- Connect the red meter lead to the red wire; then connect the black meter lead to ground.
- Meter must show battery voltage.

■NOTE: If the meter shows no battery voltage, troubleshoot the battery or the main wiring harness.

RESISTANCE

■NOTE: Perform this test on the upper side of the connector.

- Turn the ignition switch to the ON position.
- Set the meter selector to the OHMS position.
- Connect the red tester lead to the red wire; then connect the black tester lead to the red/black wire.

4. The meter must show less than 1 ohm.
5. Turn the ignition switch to the LIGHTS position.
6. Connect the red tester lead to the red wire; then connect the black tester lead to the red/black wire.
7. The meter must show less than 1 ohm.
8. Connect the red tester lead to the red wire; then connect the black tester lead to the gray wire.
9. The meter must show less than 1 ohm.
10. With the switch in the OFF position, connect the red tester lead to the red wire and the black tester lead to each of the remaining wires. The meter must show an open circuit on all wires.
11. Connect the red tester lead to the red wire and the black tester lead to the brown wire. With the switch in the ON position, the meter must show 980-1020 ohms.

NOTE: If the meter shows more than 1 ohm of resistance, troubleshoot or replace the switch/component, the connector, or the switch wiring harness.

Handlebar Control Switches

The connector is the yellow one next to the steering post. To access the connector, the steering post cover and the right-side fender splash shield must be removed (see Steering/Frame).

NOTE: These tests should be made on the top side of the connector.

CAUTION

Always disconnect the battery when performing resistance tests to avoid damaging the multimeter.

RESISTANCE (HI Beam)

1. Set the meter selector to the OHMS position.
2. Connect the red tester lead to the yellow wire; then connect the black tester lead to the gray wire.
3. With the dimmer switch in the HI position, the meter must show less than 1 ohm.

NOTE: If the meter shows more than 1 ohm of resistance, troubleshoot or replace the switch/component, the connector, or the switch wiring harness.

RESISTANCE (LO Beam)

1. Connect the red tester lead to the white wire; then connect the black tester lead to the gray wire.
2. With the dimmer switch in the LO position, the meter must show an open circuit.

NOTE: If the meter reads resistance, troubleshoot or replace the switch/component, the connector, or the switch wiring harness.

DIODE (Starter Button)

NOTE: If voltage is not as specified, check the condition of the battery in the meter prior to replacing the switch. A low battery will result in a low voltage reading during a diode test.

1. Set the meter selector to the DIODE position.
2. Connect the red tester lead to the orange/white wire; then connect the black tester lead to the yellow/green wire.
3. With the starter button depressed, the meter must show 0.5-0.7 DC volts.
4. With the starter button released, the meter must show 0 DC volts.
5. Connect the red tester lead to the yellow/green wire; then connect the black tester lead to the orange/white wire.
6. With the starter button depressed, the meter must show 0 DC volts.

NOTE: If the meter does not show as specified, replace the switch/component, connector, or switch harness.

RESISTANCE (Emergency Stop)

1. Set the meter selector to the OHMS position.
2. Connect the red tester lead to the orange wire; then connect the black tester lead to the orange/white wire.
3. With the switch in the OFF position, the meter must show an open circuit.
4. With the switch in the RUN position, the meter must show less than 1 ohm.

NOTE: If the meter shows more than 1 ohm of resistance, troubleshoot or replace the switch/component, the connector, or the switch wiring harness.

Drive Select Switch

The connector is the three-wire white snap-lock one in front of the steering post. To access the connector, the cover must be removed.

NOTE: Resistance tests should be made with the connector disconnected and on the selector-side of the connector.

RESISTANCE

1. Set the meter selector to the OHMS position.
2. Connect the red tester lead to the orange wire; then connect the black tester lead to the green/white wire.
3. With the selector switch in the 4WD position, the meter must show less than 1 ohm.
4. Connect the black tester lead to the black wire; then select the 4WD LOCK position. The meter should show less than 2 ohms.

■NOTE: If the meter does not show as specified, replace the front drive selector switch.

VOLTAGE

■NOTE: The battery must be connected when performing voltage tests.

1. Set the meter selector to the DC Voltage position.
2. Connect the black tester lead to black wire on the harness side of the connector.
3. Connect the red tester lead to the white/orange wire on the harness side of the connector.
4. Turn the ignition switch to the RUN position.
5. The meter must show approximately 8 DC volts.

■NOTE: If the meter shows other than specified, check the harness, connector, 30 amp fuse, and battery connections.

Front Drive/Differential Lock Actuator

■NOTE: With the engine stopped and the ignition switch in the ON position, a momentary “whirring” sound must be noticeable each time the selector switch is moved to 2WD and 4WD. Test the switch, 30 amp fuse, and wiring connections prior to testing the actuator.

■NOTE: The differential must be in the unlocked position for this procedure.

VOLTAGE

1. Select the 2WD position on the front drive selector switch; then disconnect the connector on the actuator wiring harness.
2. With the ignition switch in the OFF position, connect the black tester lead to the black wire in the supply harness; then connect the red tester lead to the orange wire in the supply harness.
3. Turn the ignition switch to the ON position. The meter must show approximately 11 DC volts.
4. Connect the red tester lead to the white/orange wire in the supply harness. The meter must show approximately 6 DC volts.
5. Connect the red tester lead to the white/green wire in the supply harness. The meter must show approximately 10 DC volts.
6. Select the 4WD position on the front drive selector switch; then connect the red tester lead to the white/orange wire in the supply harness. The meter must show 12 DC volts.

■NOTE: The 4WD icon on the LCD should illuminate.

7. Connect the red tester lead to the white/green wire in the supply harness. The meter must show 0 DC volts.

8. Select Differential Lock on the front drive actuator switch; then connect the red tester lead to the white/orange wire in the supply harness. The meter must show 0 DC volts.

9. Connect the tester lead to the white/green wire in the supply harness. The meter must show 0 DC volts.

■NOTE: The 4WD and LOCK icons on the LCD should illuminate.

■NOTE: If the voltage readings are as specified and the actuator does not function correctly, replace the actuator (see Drive System).



CF094C

Starter/Starter Solenoid

■NOTE: The starter is not a serviceable component and must be replaced as an assembly. Before replacing the starter, troubleshoot the starter voltage, starter relay, neutral start, and start-in-gear relays.

To replace the starter, use the following procedure.

REMOVING

1. Remove the negative battery cable from the battery.
2. Remove the left-side inner fender splash panel; then remove the seat and the left-side engine cover.
3. Disconnect the battery cable and the starter wire from the starter solenoid; then remove the two cap screws securing the starter to the V-belt housing.

INSTALLING

1. Place the starter into position in the V-belt housing; then secure with the two cap screws and tighten to 35 ft-lb.
2. Connect the battery cable to the starter solenoid; then connect the starter relay wire to the spade terminal on the starter solenoid.

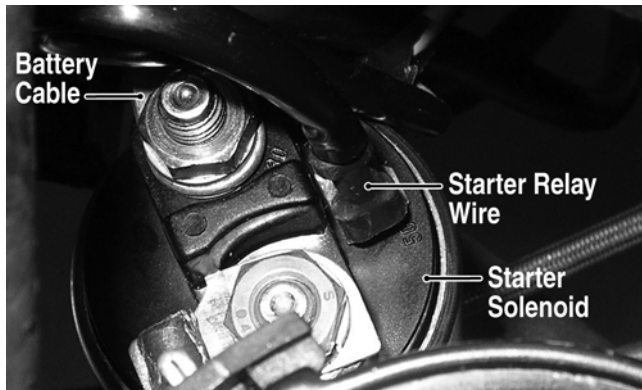

DE653A

3. Install the inner splash panel, engine cover, and seat; then connect the negative battery cable to the battery. Tighten securely.

TESTING VOLTAGE

Perform this test on the starter solenoid starter relay terminal.

■NOTE: The ignition switch must be in the ON position, the emergency stop switch in the RUN position, and the shift lever in the NEUTRAL position.

1. Set the meter selector to the DC Voltage position.
2. Connect the red tester lead to the spade terminal; then connect the black tester lead to ground.

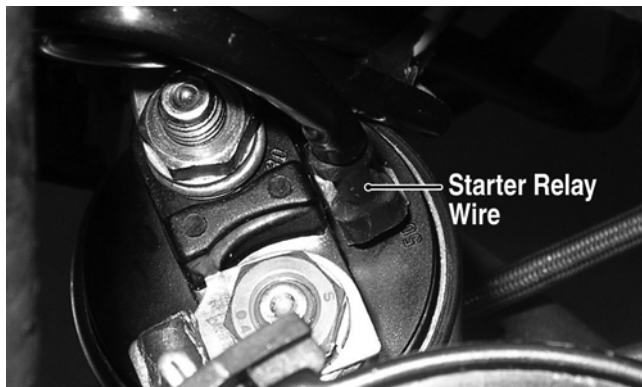

DE653B

3. With the starter button depressed, the meter must show battery voltage and the starter motor should operate.

■NOTE: If the meter showed battery voltage but the starter did not operate or operated slowly, inspect battery voltage (at the battery), starter motor condition, and/or ground connections.

■NOTE: If the meter showed no battery voltage, inspect the main fuse, ground connections, starter motor lead, battery voltage (at the battery), starter relay, or the neutral start relay.

Starter Relay

1. Remove the seat; then using the multimeter set to the DC Voltage position, check the relay as follows.

2. Connect the red tester lead to the battery terminal; then connect the black tester lead to the starter solenoid cable connection on the starter relay. The meter must show battery voltage.

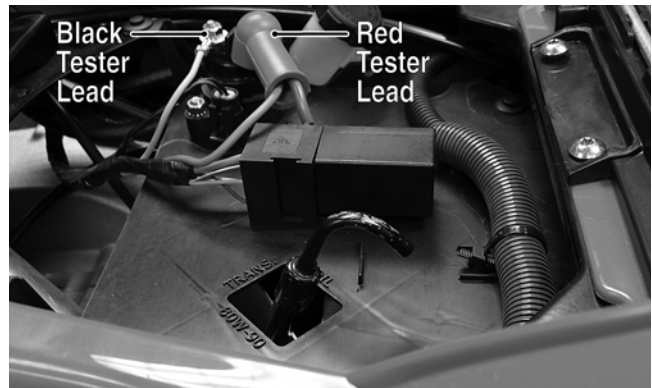

DE002B

■NOTE: Make sure that the ignition switch is in the ON position, transmission in neutral, brake lock released, and the emergency stop switch in the RUN position.

3. Depress the starter button while observing the multimeter. The multimeter should drop to 0 volts and a “click” should be heard from the relay.

■NOTE: If a “click” is heard and any voltage is indicated by the multimeter, replace the starter relay. If no “click” is heard and the multimeter continues to indicate battery voltage, proceed to step 4.

4. Disconnect the two-wire plug from the starter relay; then connect the red tester lead to the green wire and the black tester lead to the black wire.
5. Depress the starter button and observe the multimeter.

■NOTE: If battery voltage is indicated, replace the starter relay. If no voltage is indicated, check Neutral Start relay (see Fuse Block/Power Distribution Module in this section).

Alternator/Regulator

TESTING

Prior to performing the following tests, make sure the alternator belt is properly tightened and the battery is fully charged.

1. Using a suitable multimeter, select the DC Voltage position; then connect the red tester lead to the positive battery post and the black tester lead to the negative battery post.
2. Start the engine and slowly increase RPM. The voltage should increase with the engine RPM to a maximum of 15.5 DC volts.

■NOTE: If voltage rises above 15.5 DC volts, the regulator is faulty or a battery connection is loose or corroded. Clean and tighten battery connections or replace the alternator. If voltage does not rise, check all battery connections, the battery (B+) wire on the alternator, and the voltage regulator control plug-in. If all are normal, replace the alternator.

REMOVING

1. Remove the negative battery cable from the battery; then remove the seat and left-side engine cover.
2. Disconnect the battery (B+) wire from the alternator; then disconnect the voltage regulator control plug-in.

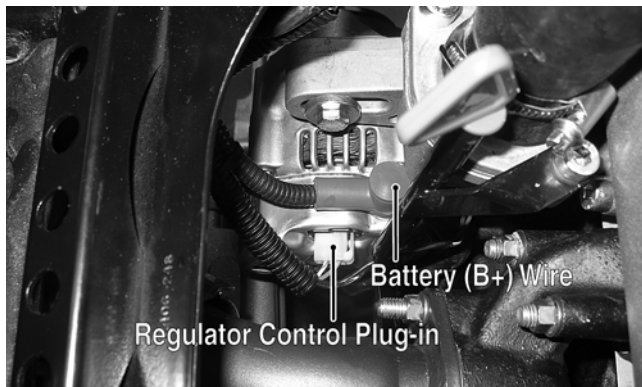

DE519B

3. Loosen the alternator adjuster cap screw (A) and the pivot bolt (B); then remove the alternator drive belt.

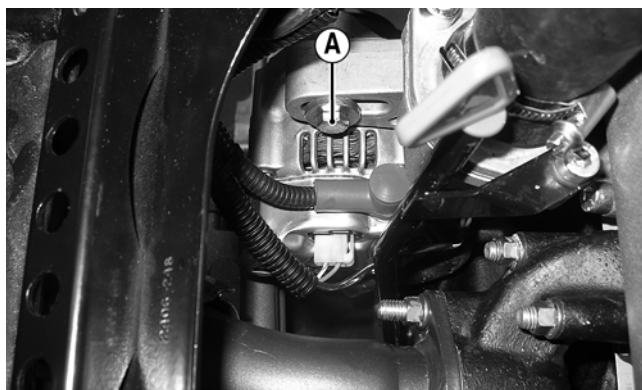

DE519C

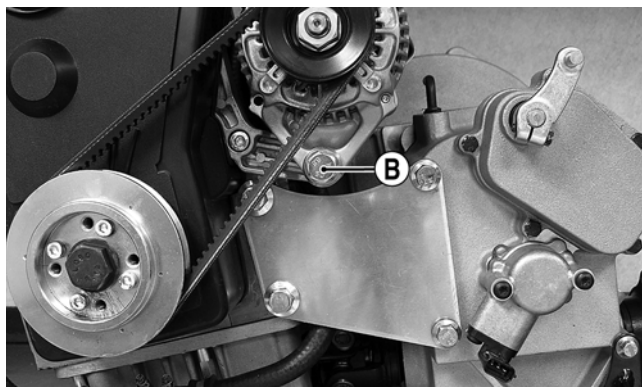

DE103C

4. Remove the adjuster cap screw and pivot bolt and remove the alternator.

■NOTE: The alternator/regulator is not a serviceable part; therefore, it must be replaced as an assembly.

INSTALLING

1. Place the alternator/regulator into position on the engine; then secure with the existing hardware. Do not tighten at this time.
2. Place the alternator drive belt into position; then using a suitable pry, tension the drive belt so that a 10 kg (22 lb) force applied at the midway point will result in a deflection of 10-15 mm (0.4-0.6 in.).

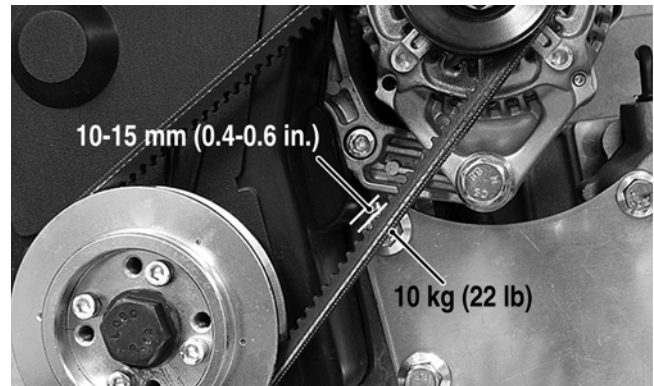

DE103B

3. Holding tension on the belt, tighten the adjuster cap screw securely; then remove the pry and tighten the pivot bolt securely.
4. Connect the battery (B+) wire and connect the regulator control plug-in; then connect the negative battery cable to the battery.
5. Install the left-side engine cover and seat making sure the seat latches securely.

Headlights

The connectors are the four 2-prong ones secured to the front bumper supports (two on each side) with cable ties.

BULB VERIFICATION (Low and High Beam)

■NOTE: Perform this test on each headlight bulb. Also, a 12-volt external power supply w/jumpers will be needed.

1. Disconnect the wiring harness from the bulb to be tested.
2. Connect the power supply (positive) to one bulb contact; then connect the power supply (negative) to the remaining bulb contact.
3. The bulb should illuminate.
4. If the bulb fails to illuminate, it must be replaced.

VOLTAGE

■NOTE: Perform this test in turn on the main harness side of all four connectors. Also, the ignition switch must be in the LIGHTS position.

■NOTE: The LO beam is the outside bulb, and the HI beam is the inside bulb.

1. Set the meter selector to the DC Voltage position.
2. Connect the red tester lead to one wire; then connect the black tester lead to the other wire.
3. With the dimmer switch in the LO position, test the two outside connectors (LO beam). The meter must show battery voltage.
4. With the dimmer switch in the HI position, test the two inside connectors (HI beam). The meter must show battery voltage.

■NOTE: If battery voltage is not shown in any test, inspect the fuses, battery, main wiring harness, connectors, or the left handlebar switch.

Taillight - Brakelight

The connector is the 3-prong one located under the rear fender assembly.

VOLTAGE (Taillight)

■NOTE: Perform this test on the main harness side of the connector. Also, the ignition switch should be in the LIGHTS position.

1. Set the meter selector to the DC Voltage position.
2. Connect the red tester lead to the white wire; then connect the black tester lead to the black wire.
3. With the ignition key in the LIGHTS position, the meter must show battery voltage.

■NOTE: If the meter shows no voltage, inspect fuses, wiring harness, connectors, and switches.

VOLTAGE (Brakelight)

■NOTE: Perform this test on the main harness side of the connector. Also, the ignition switch should be in the ON position and the brake (either foot pedal or hand lever) must be applied.

■NOTE: Make sure the brake lever (hand) and brake pedal (auxiliary) are properly adjusted for this procedure.

1. Set the meter selector to the DC Voltage position.
2. Connect the red tester lead to the red/blue wire; then connect the black tester lead to the black wire.
3. With either brake applied, the meter must show battery voltage.

■NOTE: If the meter shows no voltage, inspect bulb, fuses, wiring harness, connectors, and switches.

Fuel Solenoid

The fuel solenoid is used in conjunction with the ignition switch to control fuel flow from the lift pump to the unit injectors. This enables the operator to shut off the engine quickly using the emergency stop switch or the ignition switch. To test the fuel solenoid, use the following procedure.

1. On the multimeter, place the switch in the DC Volts position; then connect the black tester lead to a suitable ground and the red tester lead to the fuel solenoid terminal.

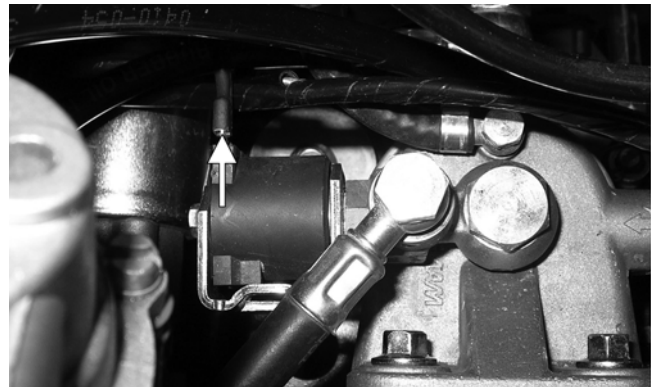

DE647B

2. With the engine stop switch in the RUN position, turn the ignition switch to the ON position. The meter should read battery voltage and an audible "click" should be heard from the fuel solenoid.
3. If no voltage is present, check the 15 amp ignition fuse, the ignition switch, or system wiring. If voltage is present, replace the fuel solenoid (see Fuel/Lubrication/Cooling).

Troubleshooting

Problem: Charging unstable	
Condition	Remedy
1. Battery connections loose or corroded 2. Alternator belt loose 3. Alternator/regulator failing	1. Clean and tighten connections 2. Tighten - replace belt 3. Replace alternator assembly
Problem: Starter button not effective	
Condition	Remedy
1. Battery charge low 2. Switch contacts defective 3. Starter solenoid defective 4. Starter relay defective 5. Emergency stop - ignition switch off 6. Wiring connections loose - disconnected	1. Charge - replace battery 2. Replace switch 3. Replace starter assembly 4. Replace relay 5. Turn on switches 6. Connect - tighten - repair connections
Problem: Battery discharges too rapidly	
Condition	Remedy
1. Battery sulfided 2. Electrical system excessively loaded 3. Charging system not charging	1. Replace battery 2. Reduce load 3. Replace alternator - tighten alternator belt
Problem: Battery polarity reversed	
Condition	Remedy
1. Battery incorrectly connected	1. Reverse connections - replace battery - repair damage

Drive System/Brake System

SPECIAL TOOLS

A number of special tools must be available to the technician when servicing the gear case.

Description	p/n
CV Boot Clamp Tool	0444-120
Pinion Gear/Shaft Removal Tool	0444-127
Gear Case Seal Installer Tool	0444-224
Slide Hammer Kit	0444-225
Internal Hex Socket	0444-104
Backlash Gauge Tool	0544-010

■**NOTE:** Special tools are available from the Arctic Cat Service Parts Department.

All gear cases are tagged beneath a cover bolt. This tag is marked with a production date code, sequence code, and a ratio code.

- A “6” or “3.6” on the lower-right corner indicates a 3.6:1 gear set ratio (10:36 teeth).
- A “1” or “3.1” on the lower-right corner indicates a 3.1:1 gear set ratio (11:34 teeth).
- A “4.0” on the lower-right corner indicates a 4.0:1 gear set ratio (9:36 teeth).

The die-cast aluminum housings have been assembled with thread-rolling screws (trilobular). When assembling with these screws, start the screws carefully into the housing; then use the following torque values.

Size	New Housing	Reassembled Housing
M6 (Torx T-30 Recess)	8-9.5 ft-lb	6.5-9 ft-lb
M8 (Torx T-40 Recess)	25-31 ft-lb	21-25 ft-lb
M10 (Torx T-50 Recess)	37-45.5 ft-lb	31-38 ft-lb

Specifications regarding the gear cases (capacities, lubricant type, etc.) can be found in the General Information section of this manual.

Ring Gear Backlash	0.28-0.38 mm (0.011-0.015 in.)
Ring Gear End Play	0.1-0.2 mm (0.004-0.008 in.)

Front Drive Actuator

■**NOTE:** The actuator is not a serviceable component. If it is defective, it must be replaced.

■**NOTE:** The actuator will operate only when the ignition switch is in the ON position.

The front drive actuator is located on the left side of the front drive input housing. With the engine stopped and the ignition switch in the ON position, a momentary “whirring” sound can be heard each time the front drive selector switch is shifted. If no sound is heard, see Electrical System. If the actuator runs constantly or makes squealing or grinding sounds, the actuator must be replaced.

REMOVING

- Remove the front inner fender panels; then disconnect the connector on the actuator harness.
- Using a T-30 torx wrench, remove the mounting cap screw from the driveshaft side of the actuator.



AG926

- Remove the mounting cap screw from below the actuator on the suspension side.

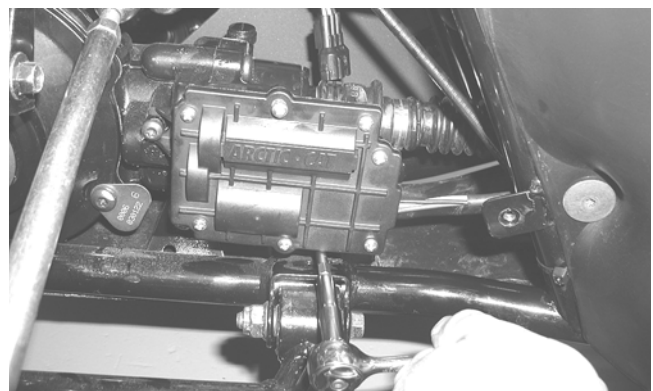

AG927

- Loosen but do not remove the mounting cap screw at the front of the actuator; then slide the actuator to the rear enough to clear the slotted mounting tab and the selector shaft.

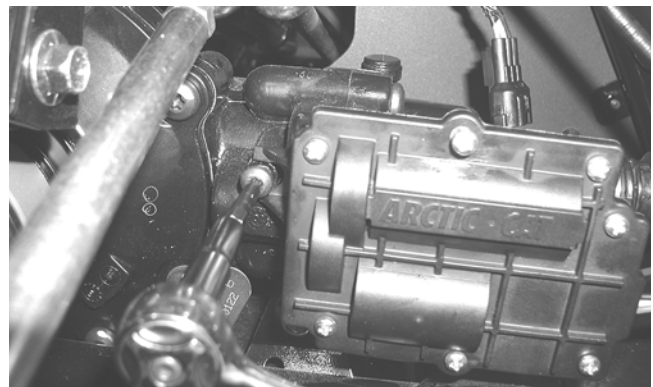

AG928

INSTALLING

1. Lubricate the O-ring on the actuator; then ensure that all mounting surfaces are clean and free of debris.
2. Align the actuator with the selector shaft and slide it forward onto the shaft taking care to engage the cap screw in the slot of the front mounting tab.

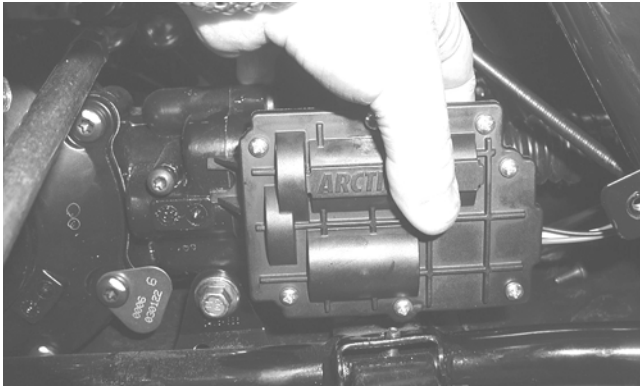

AG925

3. While holding the actuator firmly forward, tighten the front cap screw to hold the actuator in place; then install but do not tighten the two remaining cap screws.

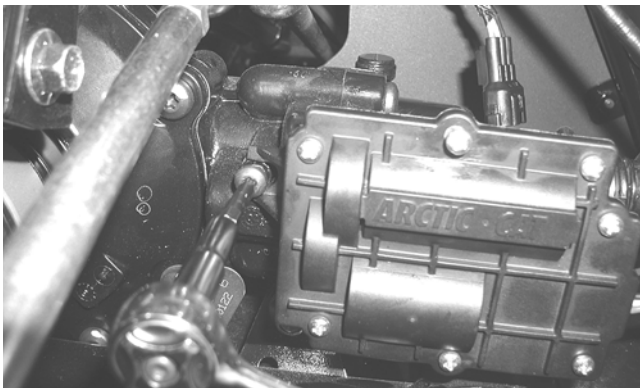

AG928

4. Loosen the front cap screw; then tighten the cap screw on the driveshaft side.



AG926

■NOTE: It is important to tighten this cap screw while the others are loose to ensure proper seating of the actuator.

5. Tighten the remaining cap screws; then connect the electrical plug to the main harness.

6. Turn the ignition switch to the ON position and check the operation by shifting the selector switch several times.
7. Secure the wiring harness to the frame with a nylon cable tie; then install the inner fender panel.

Front Differential

■NOTE: To remove the rear gear case, see Rear Gear Case in this section.

REMOVING DIFFERENTIAL

1. Secure the ATV on a support stand to elevate the wheels.

⚠ WARNING

Make sure the ATV is solidly supported on the support stand to avoid injury.

2. Remove the drain plug and drain the gear lubricant into a drain pan; then reinstall the plug and tighten to 42 in.-lb.

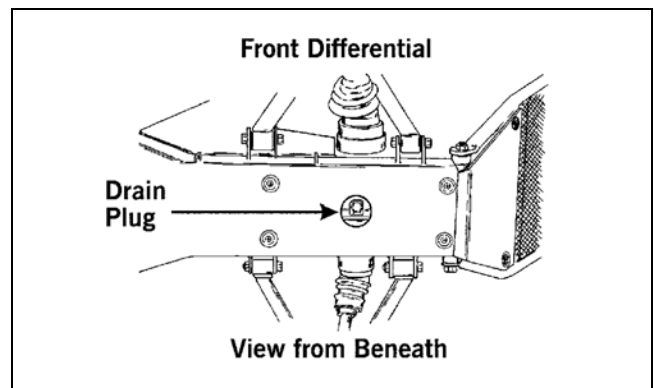

ATV0082A

3. Remove the front wheels.
4. Pump up the hand brake; then engage the brake lever lock.
5. Remove the cotter pin securing the hex nut; then remove the hex nut and washer.

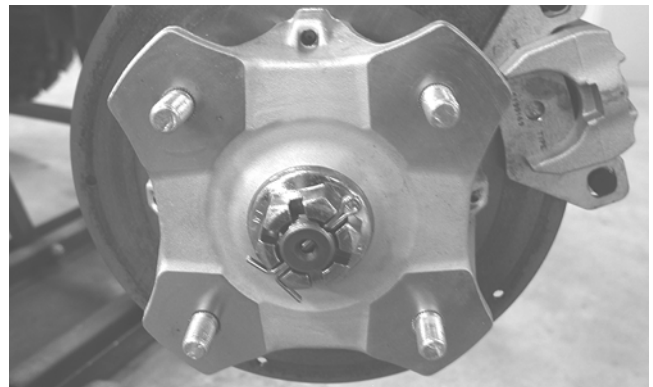

KX041

6. Release the brake lever lock.

■NOTE: It is not necessary to remove the brake hoses from the calipers for this procedure.

7. Remove the two brake calipers. Account for the four cap screws.

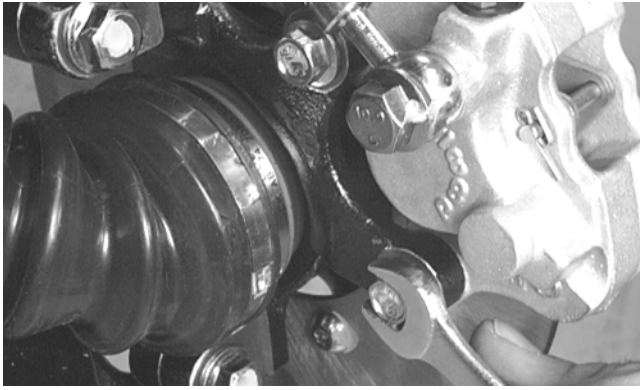

AF894D

8. Remove the tie rod cotter pins and discard the pins.

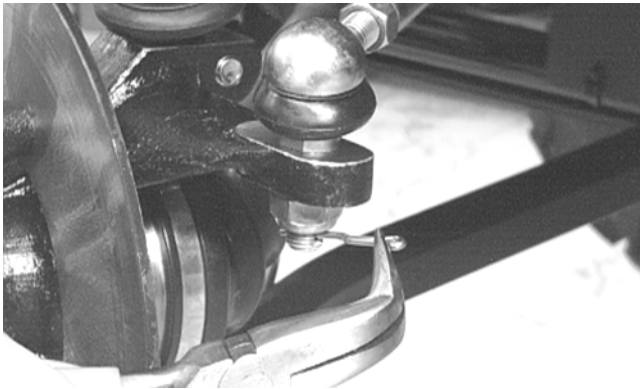

AF895D

9. Remove the tie rod lock nuts.



AF896D

10. Remove the upper ball joint cap screws taking care not to strip the threads on the ball joint shaft; then using a rubber mallet, tap the end of the axle and free it from the knuckle assembly.

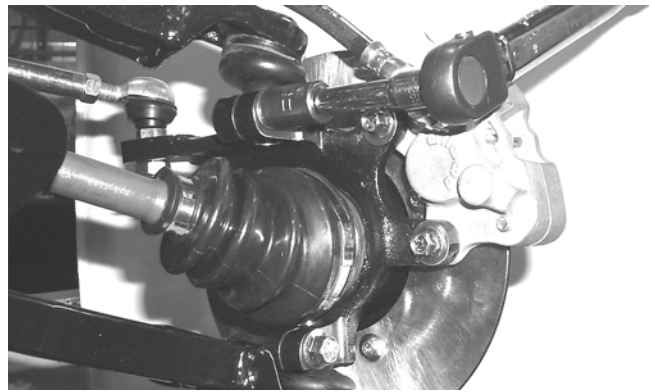

AF628D

11. Pull the steering knuckle away from the axle.

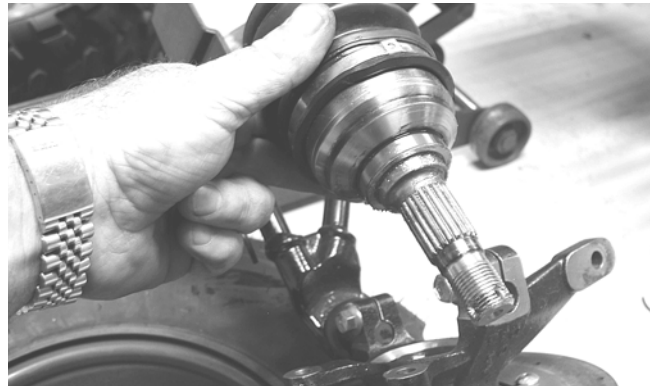

KX151

12. Support the axle to not allow it to drop or hang.

CAUTION

The axle must be supported. If the axle is allowed to drop or hang, damage to the inner CV joint may occur.

13. Remove the lower shock bolts. Account for the lock nuts; then move the shocks aside and secure them with a strap.

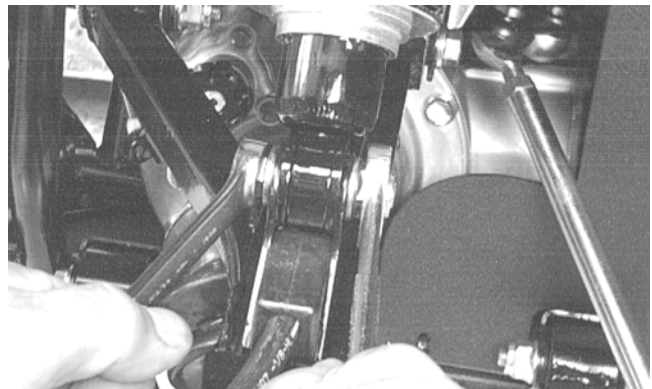

AF897D

14. Remove the upper A-arm lock nuts and cap screws; then remove the A-arms.

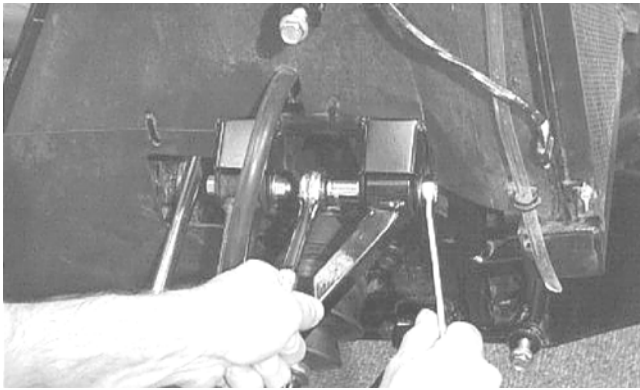

AF610D

15. Push the axle shaft firmly toward the differential to release the internal lock; then while holding the axle in, pull the CV cup from the differential.

CAUTION

Do not attempt to use a slide hammer or differential/axle damage will occur.

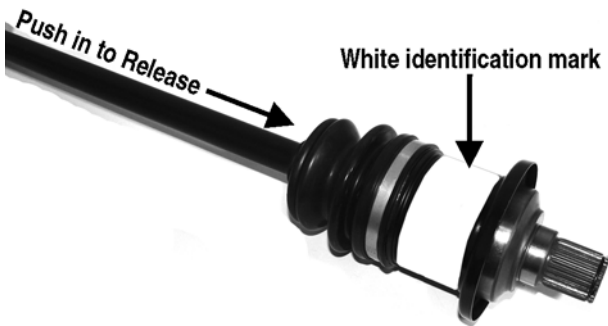

PR729B

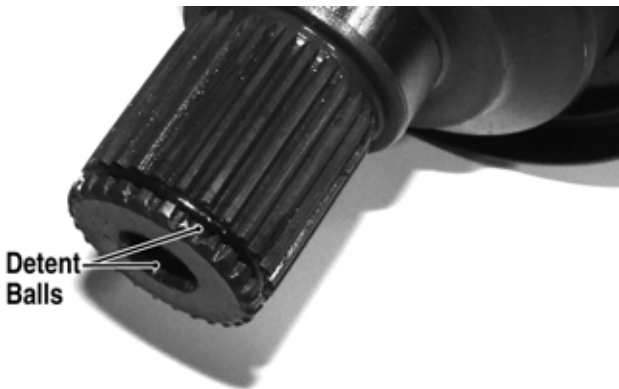

PR725A

16. Remove the inner fender panels.
 17. Using a T-30 torx wrench, remove the three screws securing the front drive actuator to the gear case; then remove the actuator.

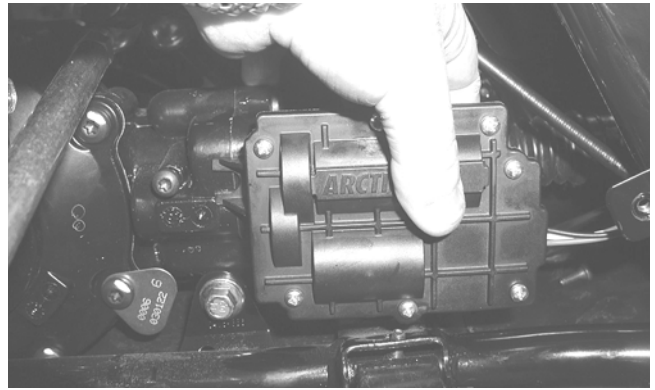

AG925

18. Remove the lower differential mounting cap screw. Account for a lock nut and washers.

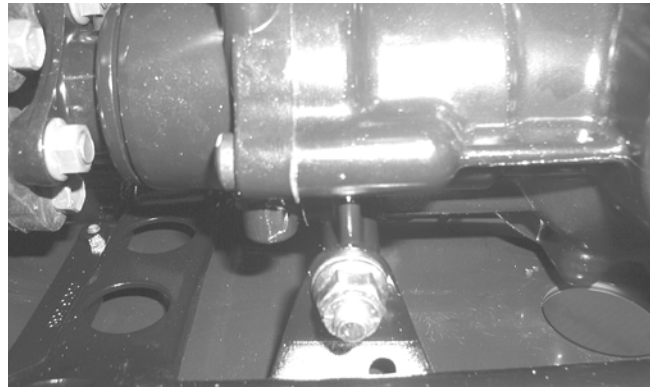

CD026

19. Remove the upper differential mounting cap screws.



CD016

20. Free the differential assembly from the frame mountings; then shift the differential assembly forward enough to disengage the front driveshaft from the output yoke.



KX161

- Place the differential on its right side; then remove it from the frame.



KX159

Disassembling Input Shaft

■NOTE: This procedure can be performed on a rear gear case; however, some components may vary from model to model. The technician should use discretion and sound judgment.

- Using a T-40 torx wrench, remove the cap screws securing the pinion housing.



GC004A

- Using a rubber mallet, remove the housing. Account for a gasket. Remove the fork, collar, and spring. Note the location of all the components for assembling purposes.



GC015

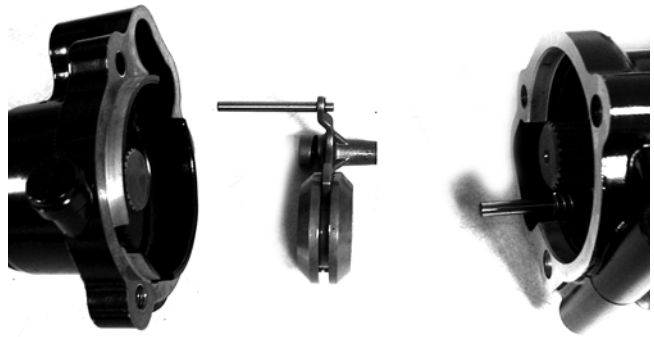

CD106

- Using a boot-clamp pliers (or suitable substitute), remove the boot clamps; then remove the boots and splined drive from the input shaft.
- Remove the input shaft from the pinion housing.



CD107

- Using a seal removal tool, remove the input shaft seal. Account for a spacer.



GC010

- Remove the snap ring securing the input shaft bearing; then place the pinion housing in a press and remove the bearing.



GC011



GC011

2. Install the input shaft seal making sure it is fully seated in the housing.

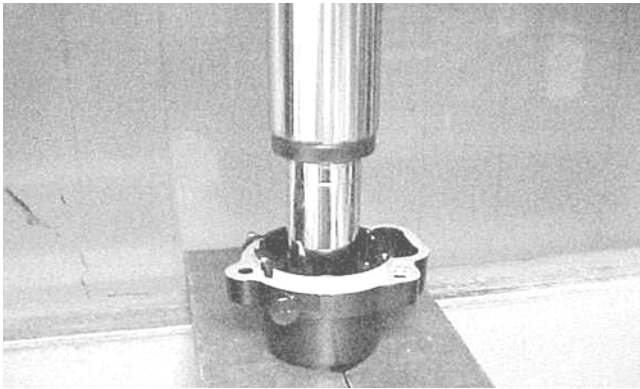

AF984



GC014

3. Lubricate the input shaft with High-Performance #2 Molybdenum Disulphide Grease packing the boot ribs and splines; then assemble allowing excess grease to freely escape. Slight pressure on the boot will be present during assembly. Secure with new clamps.

■NOTE: Any time drive splines are separated, clean all splines with parts-cleaning solvent and dry with compressed air; then lubricate with recommended grease.



KX219

Assembling Input Shaft

1. Place the pinion housing in a press and install the input shaft bearing. Secure the bearing with the existing snap ring making sure the sharp edge of the snap ring faces to the outside.



GC012



GC009A

4. Install the input shaft into the pinion housing and secure with the snap ring; then install the front boot and secure with an appropriate boot clamp and the rear boot with an appropriate boot clamp.



CD112



GC015



CD099

5. Place the pinion housing with new gasket onto the gear case housing; then secure with the existing cap screws. Tighten to 25 ft-lb.

■NOTE: If a new gear case housing is being installed, tighten the cap screws to 25-31 ft-lb.

2. Using a T-40 torx wrench, remove the cap screws securing the differential cover. Account for and make note of the ID tag location for assembling purposes.



GC003

3. Using a plastic mallet, tap lightly to remove the differential cover. Account for an O-ring.

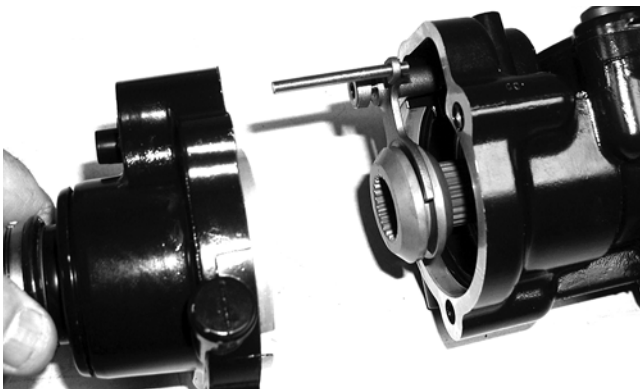

CD103



KX174

Disassembling Differential Assembly

■NOTE: This procedure can be performed on a rear gear case.

1. Using a T-40 torx wrench, remove the cap screws securing the pinion housing. Account for the coupler, fork, and spring (differential only).

■NOTE: If the cover is difficult to remove, pry on the cover in more than one recessed location.

4. Remove the splined coupler, shifter fork, pin, and spring of the differential lock assembly and set aside. Note position of parts for assembling purposes.

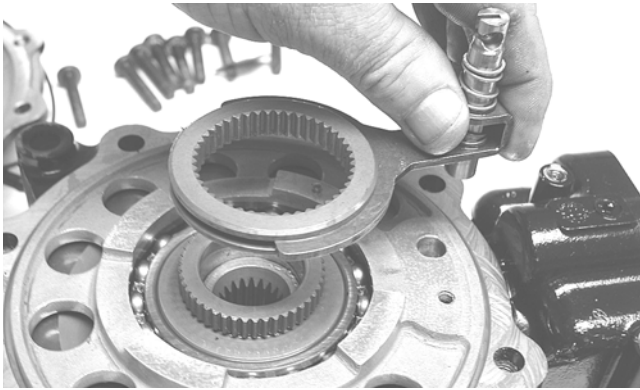

KX175

5. Remove the left differential bearing flange assembly and account for a shim. Mark the shim as left-side.

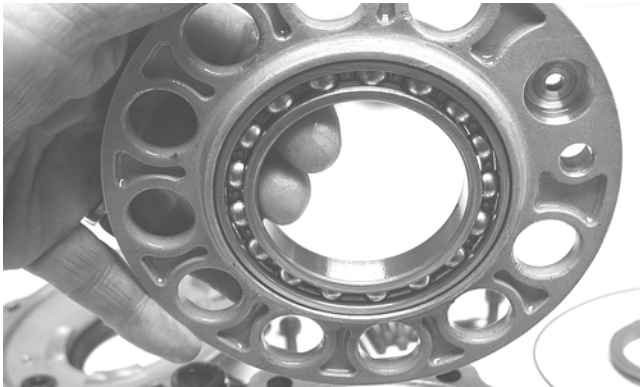

KX177



KX178

6. Place the differential with the open side down; then lift the housing off the spider assembly. Account for shim(s) and mark as right-side.



KX179

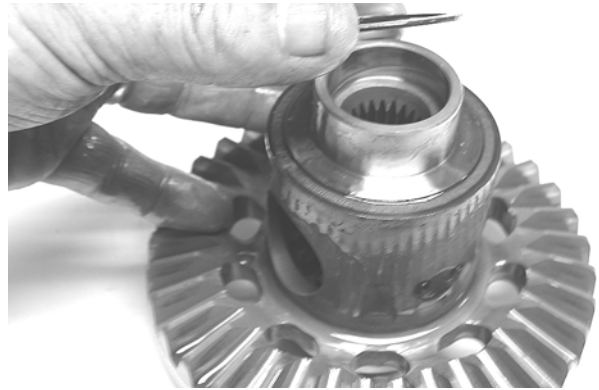

KX181

Disassembling Pinion Gear

■NOTE: Any service of the pinion gear or related bearings will require a new gear case/differential housing. The removal of the lock collar severely damages the threads in the housing.

1. Using the 48 mm Internal Hex Socket, remove the lock collar securing the pinion gear assembly.

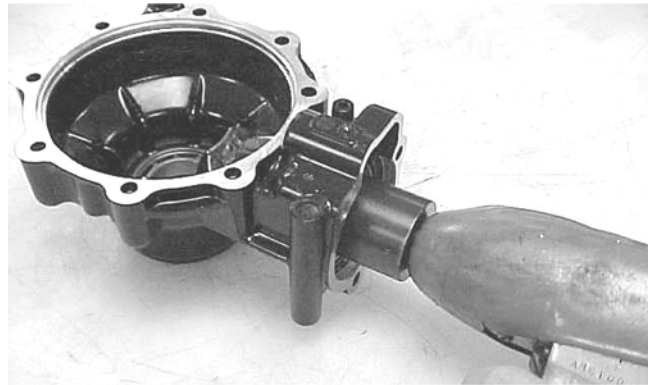

CC875



CC876

2. Using the Pinion Gear/Shaft Removal Tool and a hammer, remove the pinion gear from the gear case housing.

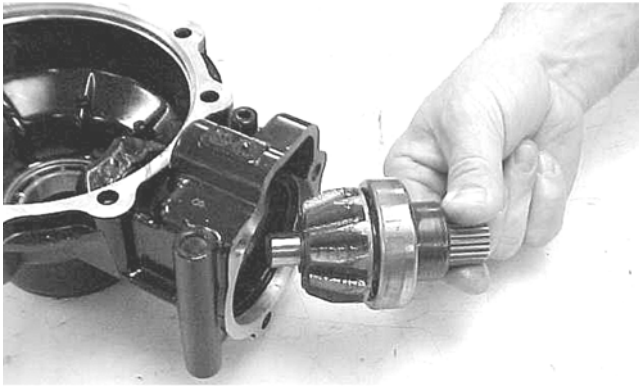

CC878

3. Secure the pinion gear in a bearing puller; then remove the pinion bearing using a press. Account for a collar and a bearing.

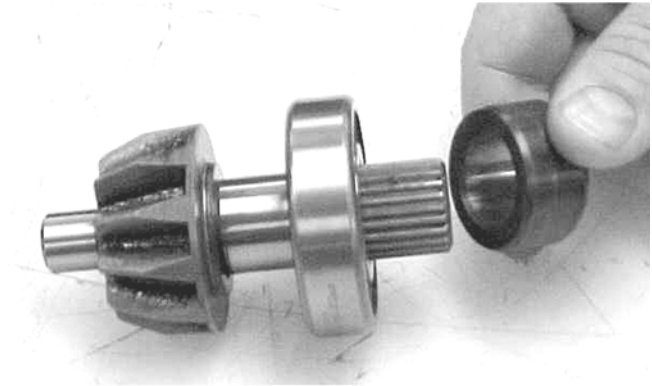

CC883

2. Place the pinion assembly in a bearing puller; then install the bearing using a press.

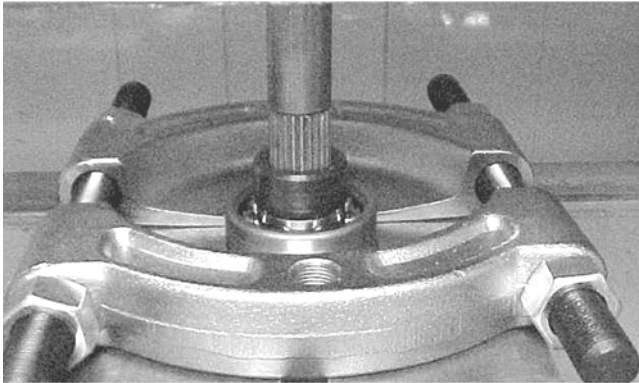

CC879

4. Remove any reusable parts from the gear case housing; then discard the housing and lock collar.

Assembling Pinion Gear

1. Install the bearing onto the pinion shaft. Install the pinion shaft collar.

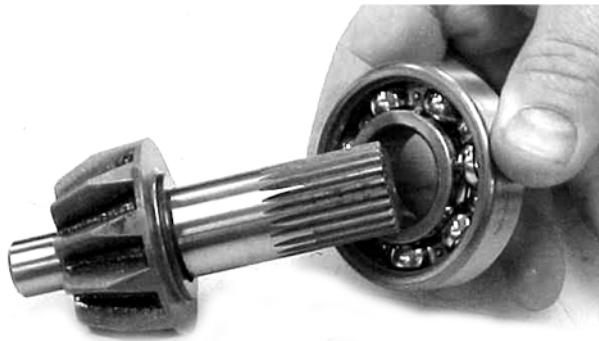

CC882

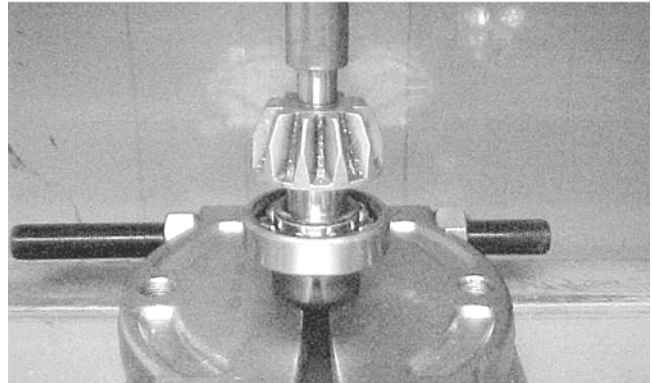

CC884

3. Coat a new needle bearing and the bearing pocket of a new gear case/differential housing with red Loctite #271; then using a suitable driver, install the bearing lightly seated against the bearing seats. Do not push the bearing too far into the pocket.



GC044

4. Install the pinion gear assembly into the housing. Using the 48 mm Internal Hex Socket, secure the pinion gear assembly with the existing lock collar. Tighten to 125 ft-lb.

■NOTE: On a front differential, the lock collar has right-hand threads. On a rear drive gear case, the lock collar has left-hand threads or a snap-ring.

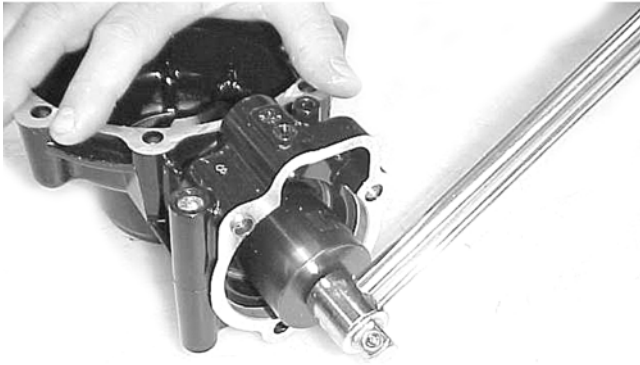

CC890

- Place a punch on the edge of the lock collar in the oil gallery area; then using a hammer, stake the lock collar to ensure that the collar will remain securely tightened.

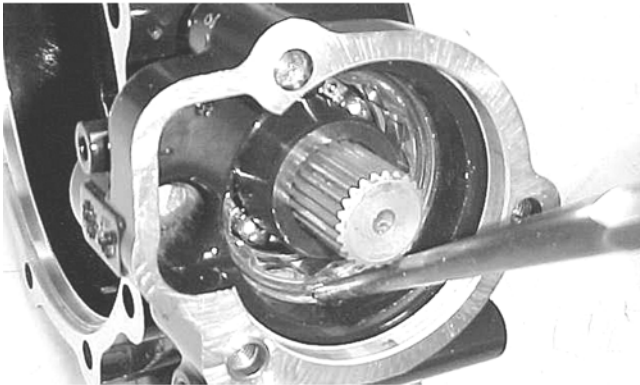

CC891

Shimming Procedure/Shim Selection

Case-Side Shims (Backlash)		
p/n	mm	in.
0402-405	1.3	0.051
0402-406	1.4	0.055
0402-407	1.5	0.059
0402-408	1.6	0.063
0402-409	1.7	0.067

Cover-Side Shims (Ring Gear End-Play)		
p/n	mm	in.
1402-074	1.3	0.051
1402-075	1.4	0.055
1402-076	1.5	0.059
1402-077	1.6	0.063
1402-078	1.7	0.067

It is very important to adjust bevel gears for the proper running tolerances. Gear life and gear noise are greatly affected by these tolerances; therefore, it is very important to properly adjust any gear set prior to final assembly.

The following procedure can be used on both front differential or rear drive gear case.

■NOTE: All bearings must be installed in the gear case and the pinion properly installed before proceeding.

Backlash

■NOTE: Always set backlash prior to any other shimming.

- Install the existing shim or a 0.051-0.055-in. shim on the gear case side of the ring gear assembly.



GC031A

- Install the ring gear with shim in the gear case; then while holding the pinion stationary, rock the ring gear forward and back to determine if any backlash exists. If no backlash exists, install a thicker shim and recheck.



GC036A

- Install the bearing flange onto the gear case cover making sure the alignment/locating pin engages the locating hole in the cover; then make sure the bearing flange is completely seated in the cover.

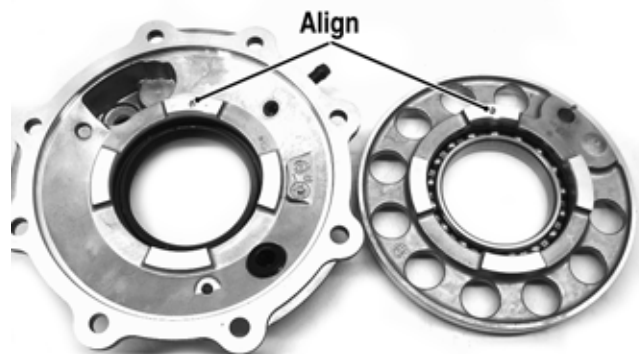

GC032A



GC033A

4. Install the existing shim or a 0.063-in. shim on the cover side of the ring gear; then place the assembled gear case cover onto the gear case and secure with three cap screws. Tighten evenly using a crisscross pattern.



GC036B

5. Place the appropriate Backlash Gauge Tool into the splines of the ring gear and install a dial indicator making sure it contacts the gauge at a 90° angle and on the index mark.



GC040

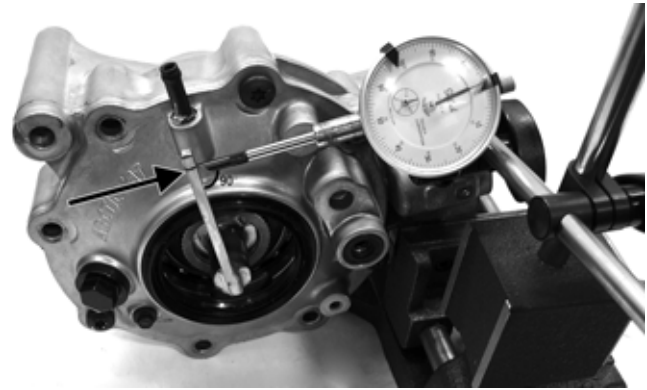

GC039A

6. Zero the dial indicator; then while holding the pinion stationary, rock the ring gear assembly forward and back and record the backlash. Backlash must be 0.011-0.015 in. If backlash is within specifications, proceed to Ring Gear End-Play. If backlash is not within specifications, increase shim thickness to increase backlash or decrease shim thickness to decrease backlash.

■NOTE: Higher backlash settings usually result in quieter gear operation.

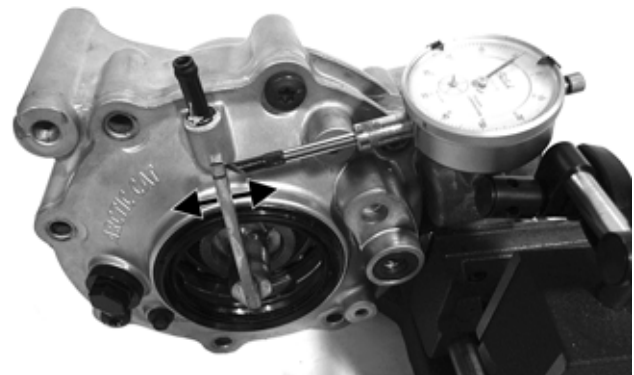

GC037A

Ring Gear End-Play

After correcting backlash, ring gear end-play can be adjusted. To adjust end-play, use the following procedure.

1. Secure the gear case in a holding fixture with the cover side up; then install a dial indicator contacting the ring gear axle flange.



GC035

2. Zero the dial indicator; then push the ring gear toward the dial indicator and release. End-play should be 0.004-0.008 in.
3. To increase end-play, decrease the shim thickness. To decrease end-play, increase the shim thickness.

■NOTE: Once proper backlash and end play are established, the gear case can be assembled (see Assembling Differential Assembly in this sub-section).



CC888

Assembling Differential Assembly

1. With the pinion gear and new bearings installed, place the selected (backlash) shim on the gear case side of the ring gear with the chamfered side toward the ring gear; then install into gear case/differential housing.



GC031A



GC020

2. Place the selected (end-play) shim, chamfered side toward the gear, onto the cover side of the ring gear.



GC036B

■NOTE: The spider and ring gear assembly must be replaced as a complete unit.

3. Assemble the fork and sliding collar into the cover assembly; then install the left bearing flange/bearing assembly and seat firmly into the cover.

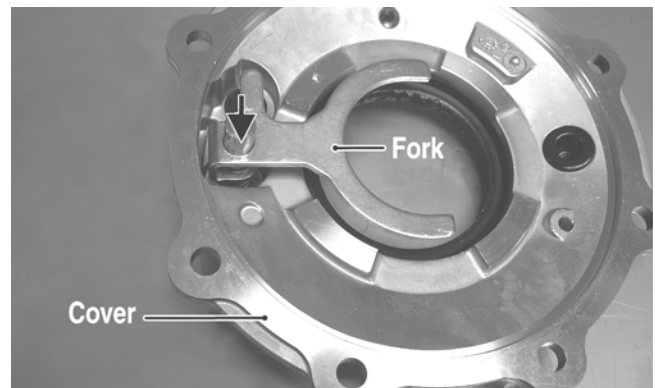

CF266A

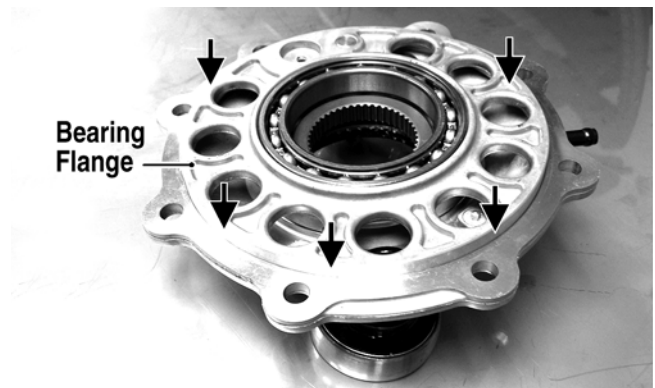

CF267A

4. Apply a liberal coat of grease to the O-ring; then install it on the assembled cover assembly making sure to seat the O-ring completely down around the circumference of the bearing flange.



CF275A

5. Making sure the O-ring is properly positioned on the differential housing cover assembly, install the cover with existing cap screws (coated with green Loctite #609). Account for the ID tag. Tighten the cap screws evenly to 23 ft-lb.

■NOTE: Grease can be applied to the O-ring for ease of assembling.

■NOTE: If a new housing is being installed, tighten the cap screws to 28 ft-lb.

6. Install the shift fork shaft w/spring into the housing making sure the shaft O-ring is positioned to the inside.

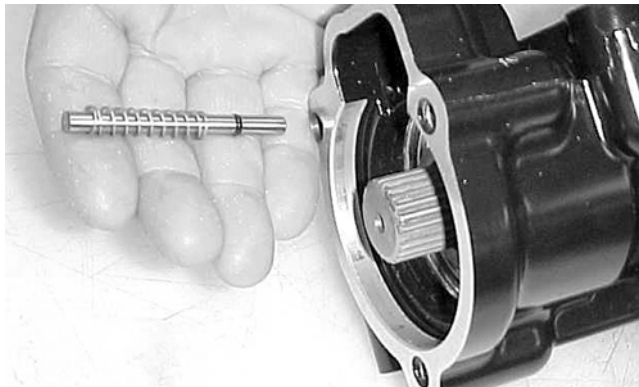

CC892

7. Install the shift fork assembly making sure the fork leg is facing upward. Apply a small amount of oil to the gasket; then install the gasket.

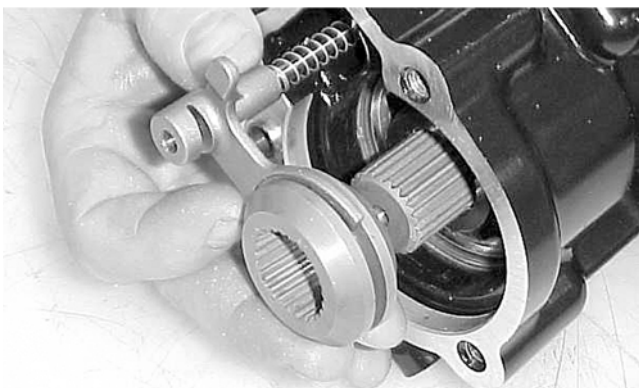

CC893

8. Place the input shaft assembly onto the gear case housing; then secure with the existing cap screws. Tighten to 23 ft-lb.

■NOTE: If a new housing is being installed, tighten the cap screws to 28 ft-lb.

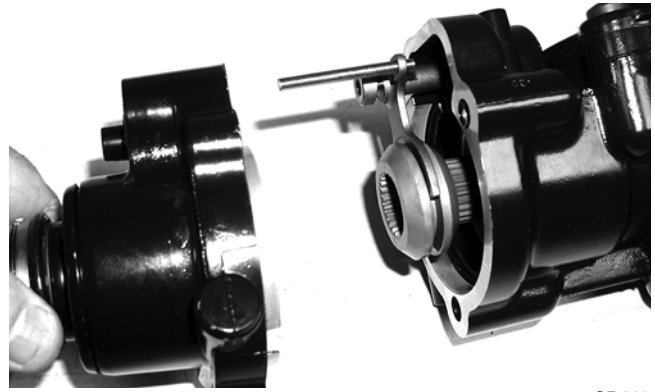

CD103



CD110

Removing/Installing Axle Seal

■NOTE: This procedure can be performed on a rear gear case.

1. Remove the seal using a seal removal tool.

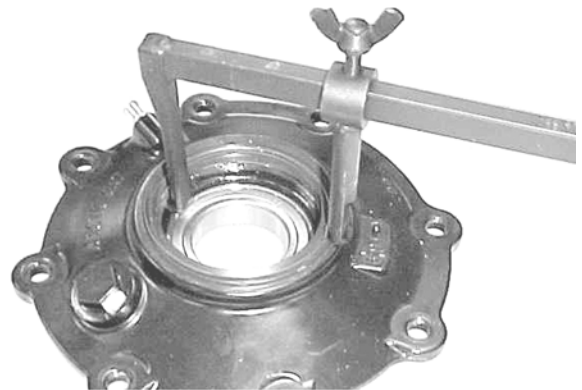

CC899

■NOTE: Prior to installing the seal, apply High-Performance #2 Molybdenum Disulphide grease to the seal outside diameter.

2. Using Gear Case Seal Installer Tool, evenly press the seal into the cover bore until properly seated.

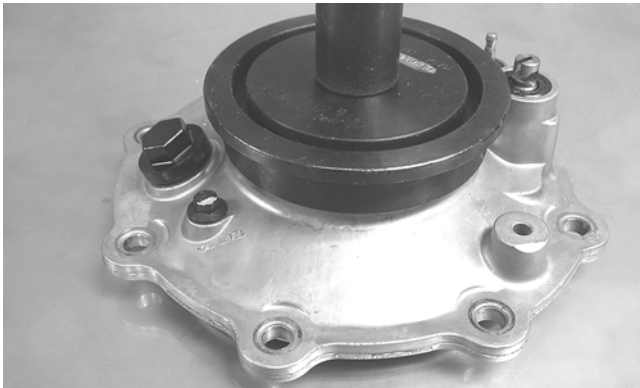

CF278

CAUTION

Make sure the tool is free of nicks or sharp edges or damage to the seal may occur.

3. Repeat steps 1-2 for the opposite side.

INSTALLING DIFFERENTIAL

1. Align the splined input yoke with the front output splines; then place the differential into position on the frame and install the cap screws, washers, and flex-lock nuts. Tighten to 38 ft-lb. Make sure the rubber boot is properly seated on the input yoke.



CD857



CD859

2. Pour 275 ml (9.3 fl oz) of SAE 80W-90 hypoid gear lubricant into the differential and install the fill plug. Tighten to 16 ft-lb.

3. Install the front drive actuator with the three torx-head cap screws; then connect the wire connector to the main wiring harness.

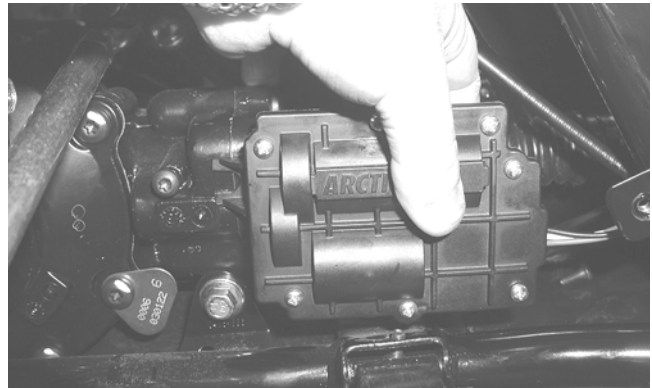

AG925

4. Install the inner fender panels.

5. Install the front axles (see Drive Axles in this section).

6. Secure the upper A-arms with cap screws and lock nuts. Tighten to 50 ft-lb.

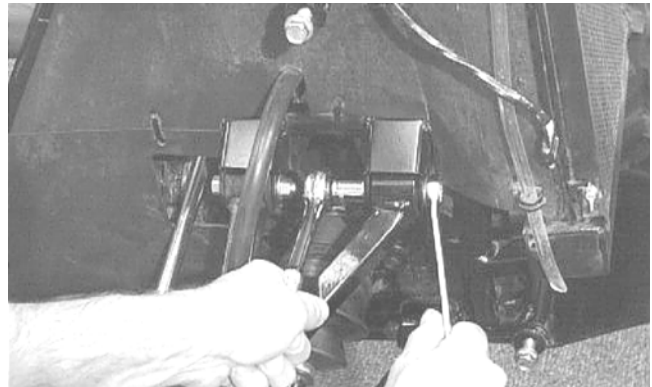

AF610D

7. Secure the lower shock eyelets with cap screws and lock nuts. Tighten to 50 ft-lb.

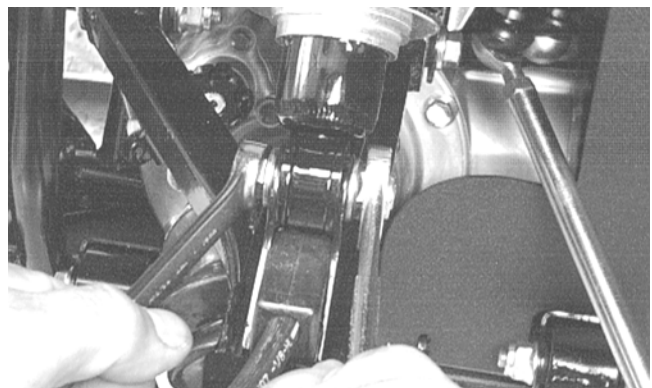

AF897D

8. Secure the tie rods with the lock nuts. Tighten to 35 ft-lb; then install and spread the cotter pins.

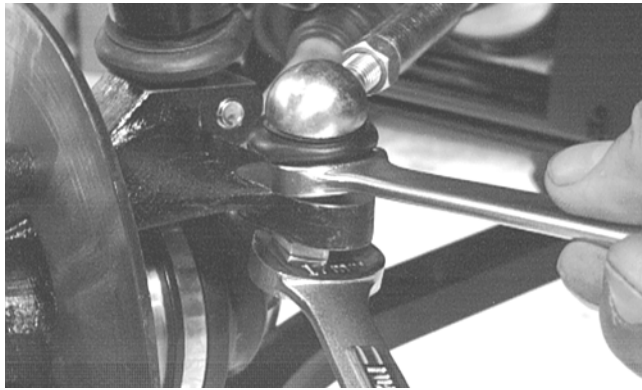

AF896D

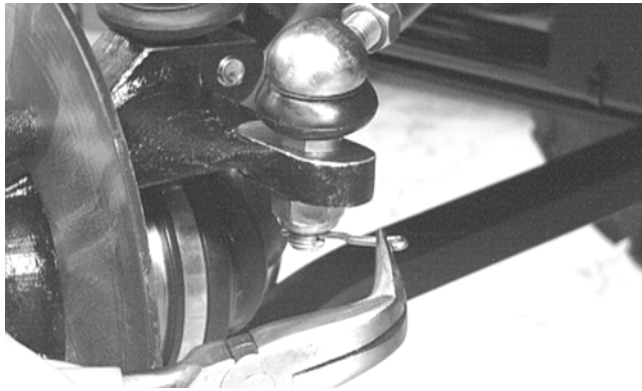

AF895D

9. Install the brake calipers and secure with new "patch-lock" cap screws tightened to 20 ft-lb.



AF894D

10. Install the wheels and tighten to 45 ft-lb (steel wheels) or 80 ft-lb (aluminum wheels).
11. Remove the ATV from the support stand.

Drive Axles

REMOVING REAR DRIVE AXLE

1. Secure the ATV on a support stand to elevate the wheels.

⚠ WARNING

Make sure the ATV is solidly supported on the support stand to avoid injury.

2. Pump up the hand brake; then engage the brake lever lock.

3. Remove the wheel.
4. Remove the cotter pin securing the hex nut; then remove the hex nut. Release the brake lever lock.

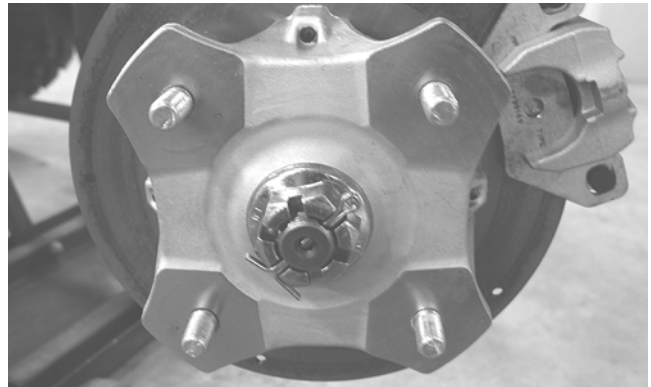

KX041

5. Remove the two brake calipers (right side only).

■NOTE: Do not allow the brake calipers to hang from their cable/hose.

CAUTION

The calipers should be supported. If the calipers are allowed to hang from the cable/hose, damage may occur.

6. Slide the hub out of the knuckle and set aside.
7. Remove the cap screw and lock nut securing the knuckle to the upper A-arm. Discard the lock nut.

■NOTE: Never reuse a lock nut. Once a lock nut has been removed, it must be replaced with a new lock nut.

8. While holding the drive axle stationary, pull the top of the knuckle out and down until it is free of the drive axle.
9. Place a drain pan under the ATV to contain any oil leakage.
10. Push the axle shaft firmly toward the gear case to release the internal lock; then while holding the axle in, pull the CV cup from the gear case.

CAUTION

Do not attempt to use a slide hammer or gear case/axle damage will occur.

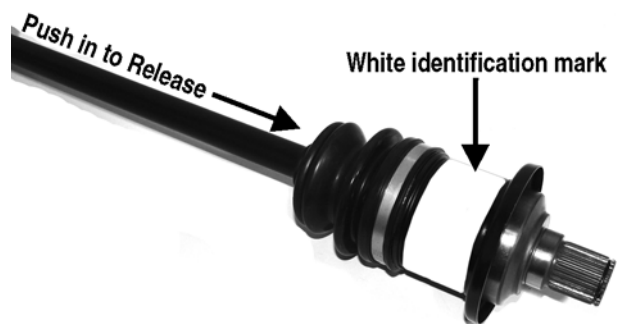

PR729B



Detent Balls

PR725A



Detent Balls

PR725A

REMOVING FRONT DRIVE AXLE

■NOTE: For removing a front drive axle, see Front Differential in this section.

CLEANING AND INSPECTING

■NOTE: Always clean and inspect the drive axle components to determine if any service or replacement is necessary.

1. Using a clean towel, wipe away any oil or grease from the axle components.



CD019

2. Inspect boots for any tears, cracks, or deterioration.

■NOTE: If a boot is damaged in any way, it must be replaced with a boot kit.

3. Inspect the gear case seals for nicks or damage.

DISASSEMBLING/ASSEMBLING AXLES

■NOTE: To disassemble/assemble axles, refer to the appropriate boot kit instructions.

INSTALLING REAR DRIVE AXLE

1. Push the axle shaft into the CV cup to release the detent balls; then while holding the axle firmly in, push the CV splined end into the gear case.



PR729B

■NOTE: To assure proper seating of the axle, give it a light pull; the axle should remain “clipped” in place.

2. Swing the knuckle up and onto the drive axle; then place the knuckle into place in the upper A-arm. Secure the knuckle to the A-arm with a cap screw and a new lock nut. Tighten to 35 ft-lb.
3. Place the hub into position on the axle followed by a hex nut. Tighten the hex nut finger-tight at this time.
4. If the brake calipers were removed, position them on the knuckle and secure with new “patch-lock” cap screws. Tighten the auxiliary brake caliper cap screws to 20 ft-lb. Tighten the hydraulic brake caliper cap screws to 20 ft-lb.
5. Pump up the hand brake lever; then engage the brake lever lock.
6. Tighten the hub hex nut (from step 3) to 200 ft-lb; then install and spread a new cotter pin making sure each side of the pin is flush to the hub nut.

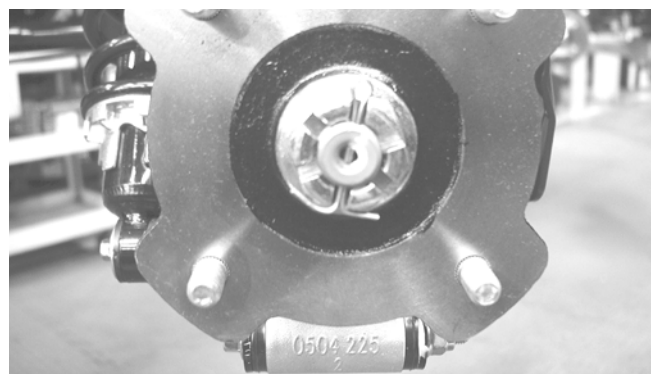

CD027

7. Install the wheel. Tighten to 45 ft-lb (steel wheels) or 80 ft-lb (aluminum wheels).

- Remove the ATV from the support stand and release the brake lever lock.

INSTALLING FRONT DRIVE AXLE

- Position the drive axle in the gear case and steering knuckle; then insert the upper A-arm ball joint into the steering knuckle. Secure with a cap screw tightened to 50 ft-lb.
- Place the brake hose into position on the upper A-arm; then secure the lower shock eyelet to the A-arm with a cap screw and a new lock nut. Tighten to 50 ft-lb.
- Secure the tie rod to the steering knuckle with a new lock nut. Tighten securely; then install and spread a new cotter pin.
- Slide the hub w/brake disc into position in the steering knuckle followed by a washer and hex nut. Tighten finger-tight at this time.
- Install the brake caliper on the steering knuckle using new "patch-lock" cap screws. Tighten to 20 ft-lb; then pump up the hand brake lever and engage the brake lever lock.
- Tighten the hub hex nut (from step 4) to 200 ft-lb; then install and spread a new cotter pin making sure each side of the pin is flush to the hub nut.

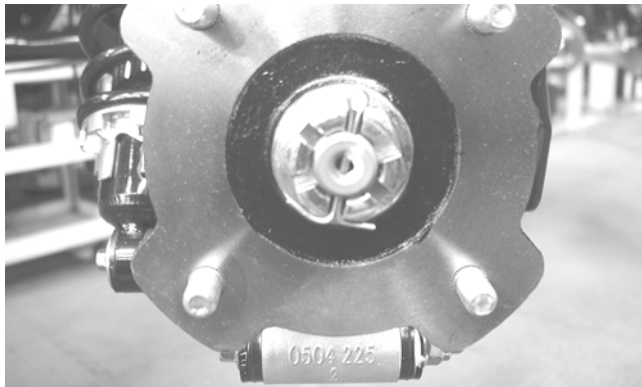

CD027

- Install the wheel and tighten to 45 ft-lb (steel wheels) or 80 ft-lb (aluminum wheels).
- Remove the ATV from the support stand and release the brake lever lock.
- Check the front differential oil level and add oil as necessary.

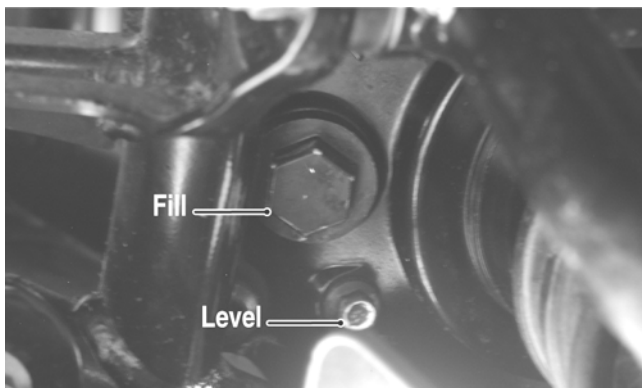

CF113A

Rear Gear Case

REMOVING

- Remove the left-side rear A-arms (see Rear A-Arms in Suspension).
- Remove both of the rear drive axles (see Drive Axles in this section).
- Remove the four cap screws securing the engine output shaft to the rear gear case input flange.

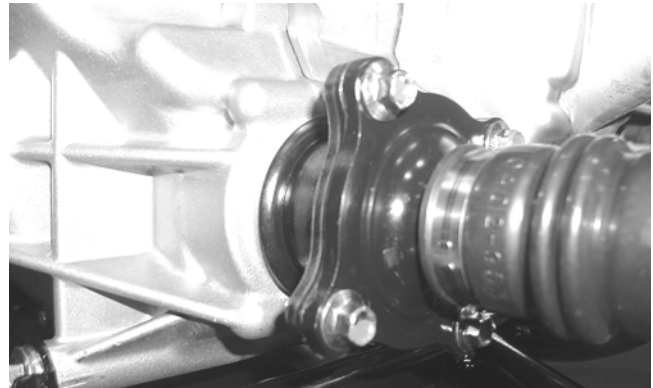

CD028

- Remove the two cap screws and lock nuts securing the rear gear case to the frame; then remove the gear case through the left side.

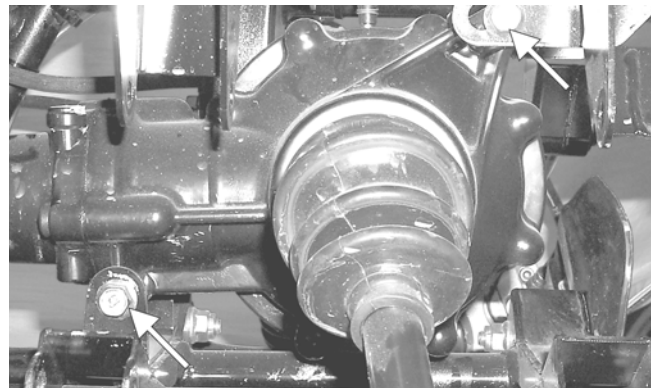

AF960A

⚠ AT THIS POINT

For servicing the input shaft, pinion gear, needle bearing, ring gear, and axle seal, see Front Differential in this section.

RING GEAR/THRUST BUTTON

Removing

- Remove the cap screws securing the gear case cover to the gear case; then remove the ring gear.
- Remove the thrust button from the gear case cover (left-hand threads). Account for a shim.

Inspecting

- Inspect the ring gear for excessive wear, missing or chipped teeth, or discoloration.

2. Inspect the thrust button for excessive wear or discoloration.
3. Inspect the bearings for discoloration, roughness, or excessive wear.

■NOTE: For servicing bearings or seals, see Front Differential in this section.

Installing/Shimming

■NOTE: Ring gear clearance must be adjusted prior to selecting shim for the thrust button.

1. Install the thrust button with shim into the gear case cover and tighten securely (left-hand threads).

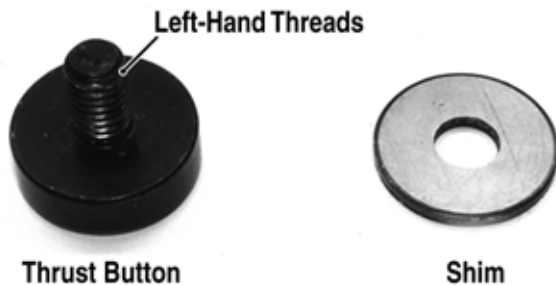

GC057A

2. Place the ring gear with selected shim into the cover and measure the ring gear to thrust button clearance with a thickness gauge. Clearance should be 0.002-0.004 in.

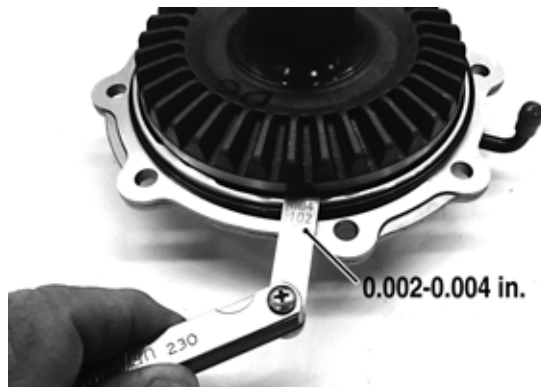

GC058A

3. If clearance is as specified, remove the ring gear and thrust button; then place a drop of red Loctite #271 on the threads and tighten to 8 ft-lb (left-hand threads).
4. If clearance is not as specified, repeat steps 1 and 2 using thicker (clearance too great) or thinner (clearance too small) until correct specification is reached.

INSTALLING

1. Slide the gear case into position through the left side of the frame; then secure it to the frame with cap screws and lock nuts. Tighten to 38 ft-lb.
2. Secure the engine output shaft to the rear gear case input flange with four cap screws and lock nuts. Tighten to 20 ft-lb.

3. Install the rear drive axles (see Drive Axles in this section).
4. Install the left-side rear A-arms (see Rear A-Arms in Suspension).

Hub

REMOVING

1. Secure the ATV on a support stand to elevate the wheel; then remove the wheel.

⚠ WARNING

Make sure the ATV is solidly supported on the support stand to avoid injury.

2. Remove the cotter pin from the nut.

■NOTE: During assembly, new cotter pins should be installed.

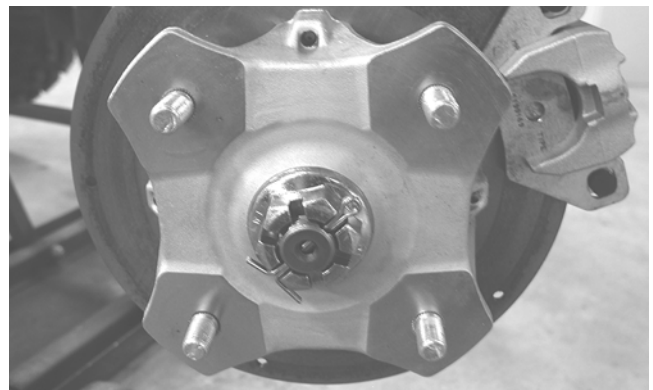

3. Remove the flange nut securing the hub.
4. Remove the brake caliper.

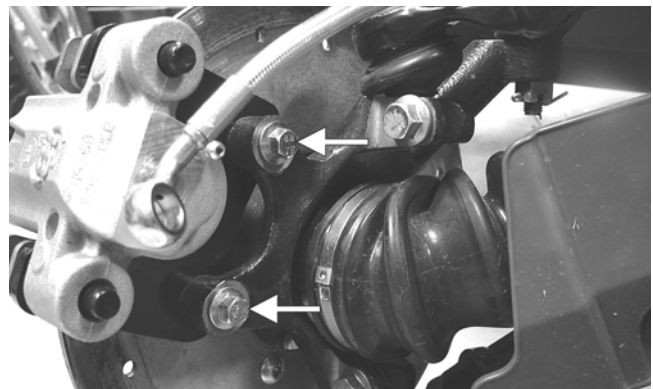

5. Remove the hub assembly.
6. Remove the four cap screws securing the brake disc.

CLEANING AND INSPECTING

■NOTE: Whenever a part is worn excessively, cracked, or damaged in any way, replacement is necessary.

1. Clean all hub components.

2. Inspect all threads for stripping or damage.
3. Inspect the brake disc for cracks or warping.
4. Inspect the hub for pits, cracks, loose studs, or spline wear.

INSTALLING

1. Secure the brake disc to the hub with the four cap screws coated with blue Loctite #243. Tighten to 15 ft-lb.
2. Apply grease to the splines in the hub.



PR291

3. Install the hub assembly onto the shaft.



PR290

4. Secure the hub assembly with the nut. Tighten only until snug.
5. Secure the brake caliper to the knuckle with new "patch-lock" cap screws. Tighten the auxiliary caliper to 20 ft-lb. Tighten the hydraulic caliper to 20 ft-lb.

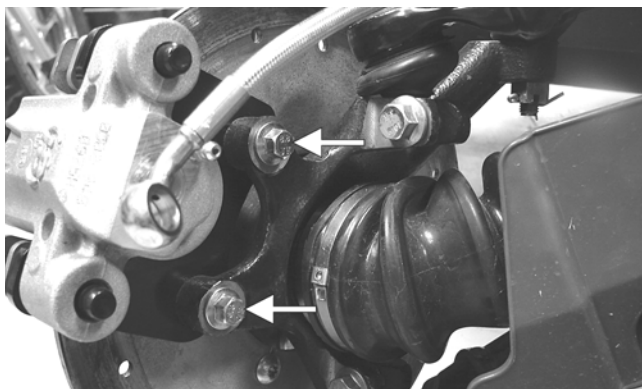

PR243A

6. Tighten the hub nut (from step 4) to 200 ft-lb; then install and spread a new cotter pin making sure each side of the pin is flush to the hub nut.

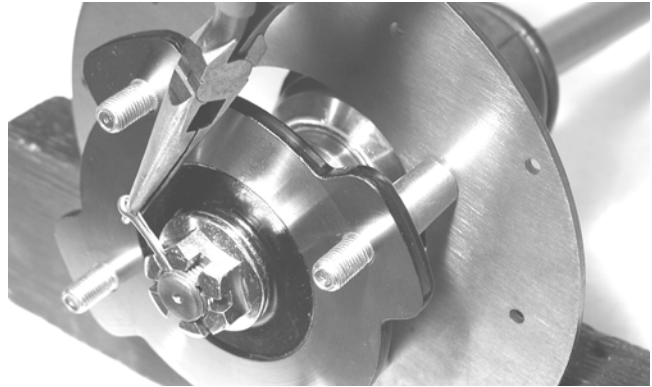

CD008

7. Install the wheel and tighten to 45 ft-lb (steel wheels) or 80 ft-lb (aluminum wheels).
8. Remove the ATV from the support stand.

Hydraulic Brake Caliper

⚠ WARNING

Arctic Cat recommends that only authorized Arctic Cat ATV dealers perform hydraulic brake service. Failure to properly repair brake systems can result in loss of control causing severe injury or death.

REMOVING/DISASSEMBLING

1. Secure the ATV on a support stand to elevate the wheel; then remove the wheel.

⚠ WARNING

Make sure the ATV is solidly supported on the support stand to avoid injury.

⚠ WARNING

Never let brake fluid contact the eyes. Damage to the eyes will occur. Always wear appropriate protective safety goggles and latex gloves when handling brake fluid.

2. Drain the brake fluid from the caliper, hose, and master cylinder through the bleed screw by pumping the brake lever/pedal.



PR235

CAUTION

Brake fluid is highly corrosive. Do not spill brake fluid on any surface of the ATV and do not reuse brake fluid.

■NOTE: Whenever brake components are removed, disassembled, or repaired where brake fluid is exposed to air, drain all fluid and replace with new DOT 4 brake fluid from an unopened container. Brake fluid readily absorbs moisture from the air significantly lowering the boiling point. This increases the chance of vapor lock reducing braking power and increasing stopping distance.

3. Remove the brake hose from the caliper and close the bleed screw; then remove the caliper.
4. Compress the caliper holder against the caliper (opposite the O-ring side) and remove the outer brake pad; then remove the inner brake pad.

■NOTE: If brake pads are to be returned to service, do not allow brake fluid to contaminate them.



PR237A



PR238

5. Remove the caliper holder from the caliper and discard the O-ring.

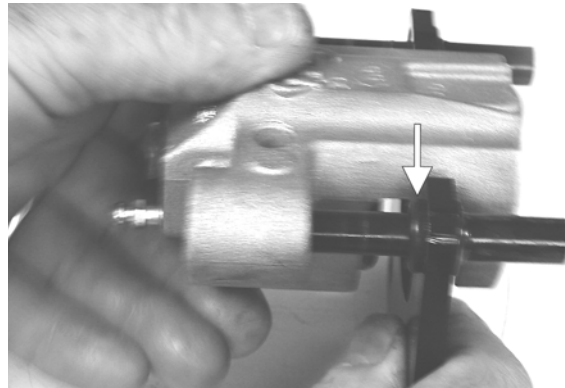

PR239B

■NOTE: The O-ring is used for shipping purposes and provides no function in operation.

6. Cover the piston end of the housing with a shop towel; then keeping fingers clear of piston travel, apply compressed air to the fluid port to blow the piston free of the housing. Account for two seal rings in the housing.

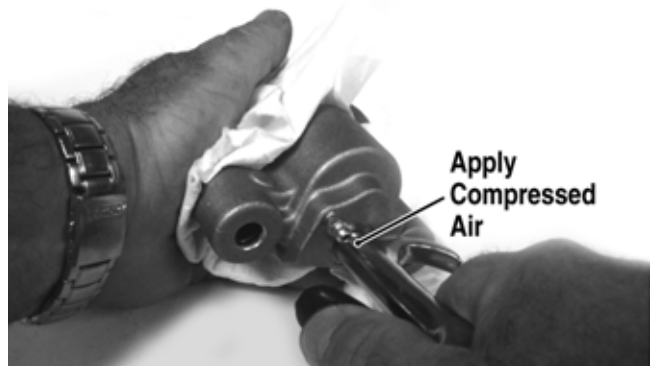

PR713A



PR715

⚠ WARNING

Make sure to hold the towel firmly in place or the piston could be ejected from the housing causing injury.

7. Using an appropriate seal removal tool, carefully remove the seals from the brake caliper housing; then remove four O-rings from the brake caliper housing noting the location of the different sized O-rings. Discard all seals, O-rings, and crush washers.

CLEANING AND INSPECTING

1. Clean all caliper components (except the brake pads) with DOT 4 brake fluid. Do not wipe dry.

2. Inspect the brake pads for damage and excessive wear.

■NOTE: For measuring brake pads, see Periodic Maintenance/Tune-Up.

3. Inspect the brake caliper housings for scoring in the piston bores, chipped seal ring grooves, or signs of corrosion or discoloration.
4. Inspect the piston surface for scoring, discoloration, or evidence of binding or galling.
5. Inspect the caliper holder for wear or bending.

ASSEMBLING/INSTALLING

1. Install new seals into the brake caliper housing and apply a liberal amount of DOT 4 brake fluid to the cylinder bore of the housing, seals, and brake piston.

CAUTION

Make sure the seals are properly in place and did not twist or roll during installation.



PR715

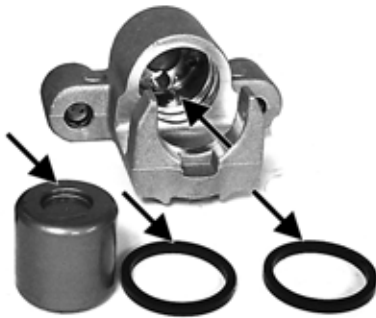

PR717A

2. Press the piston into the caliper housing using hand pressure only. Completely seat the piston; then wipe off any excessive brake fluid.



PR711A



PR712

3. Apply high-temperature silicone grease (supplied with the O-ring kit) to the inside of the caliper holder bores and O-rings; then install the four O-rings into the caliper.

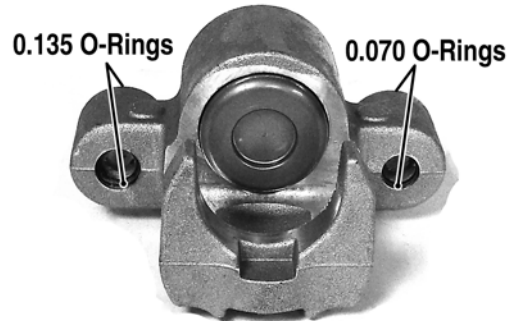

PR719C

4. Install the caliper onto the caliper holder making sure the caliper and holder are correctly oriented.

■NOTE: It is very important to apply silicone grease to the O-rings and caliper bores prior to assembly.

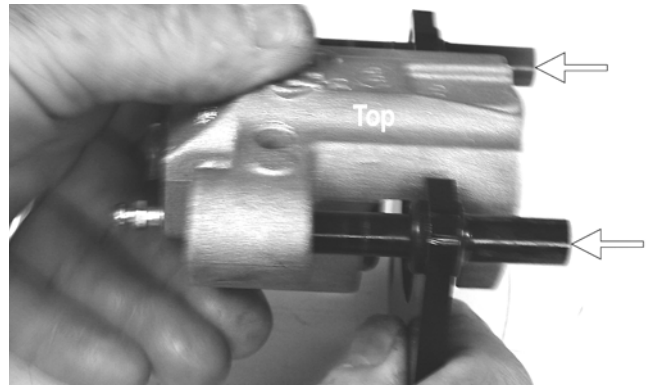

PR239C

5. Making sure brake fluid does not contact the brake pads, compress the caliper holder toward the caliper and install the inner brake pad; then install the outer pad.

CAUTION

If brake pads become contaminated with brake fluid, they must be thoroughly cleaned with brake cleaning solvent or replaced with new pads. Failure to do so will result in reduced braking and premature brake pad failure.



PR238

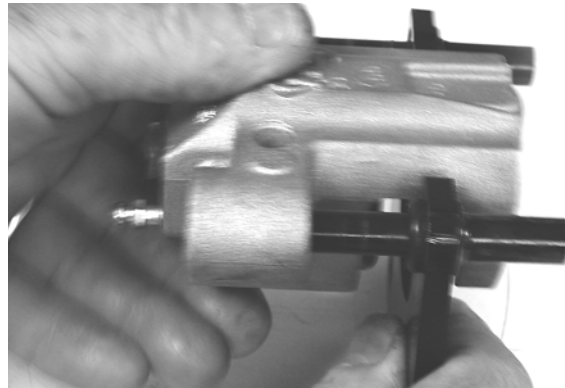

PR239

6. Place the brake caliper assembly into position and secure with new "patch-lock" cap screws. Tighten the caliper to 20 ft-lb.
7. Place a new crush washer on each side of the brake hose fitting and install it on the caliper. Tighten to 20 ft-lb.
8. Fill the reservoir; then bleed the brake system (see Periodic Maintenance/Tune-Up).

⚠ WARNING

Never use brake fluid from an open container or reuse brake fluid. Moisture-contaminated brake fluid could cause vapor build-up (expansion) during hard braking resulting in greatly increased stopping distance or loss of control leading to injury or death.

9. Install the wheel. Tighten to 45 ft-lb (steel wheels) or 80 ft-lb (aluminum wheels).
10. Remove the ATV from the support stand and verify brake operation.

Troubleshooting Drive System

Problem: Power not transmitted from engine to wheels

Condition	Remedy
1. Rear axle shafts serration worn - broken	1. Replace shaft

Problem: Power not transmitted from engine to either front wheel

Condition	Remedy
1. Secondary drive - driven gear teeth broken	1. Replace gear(s)
2. Propeller shaft serration worn - broken	2. Replace shaft
3. Coupling damaged	3. Replace coupling
4. Coupling joint serration worn - damaged	4. Replace joint
5. Front drive - driven bevel gears broken - damaged	5. Replace gear(s)
6. Front differential gears/pinions broken - damaged	6. Replace gears - pinions
7. Sliding dogs/shaft fork worn - damaged	7. Replace gear(s)
8. Front drive axle worn - damaged	8. Replace axle
9. Front drive axle serration worn - damaged	9. Replace axle

Troubleshooting Brake System

Problem: Braking poor	
Condition	Remedy
1. Pad worn 2. Pedal free-play excessive 3. Brake fluid leaking 4. Hydraulic system spongy 5. Master cylinder/brake cylinder seal worn	1. Replace pads 2. Replace pads 3. Repair - replace hydraulic system component(s) 4. Bleed hydraulic system - correct or repair leaks 5. Replace master cylinder
Problem: Brake lever travel excessive	
Condition	Remedy
1. Hydraulic system entrapped air 2. Brake fluid low 3. Brake fluid incorrect 4. Piston seal - cup worn	1. Bleed hydraulic system 2. Add fluid to proper level 3. Drain system - replace with correct fluid 4. Replace master cylinder
Problem: Brake fluid leaking	
Condition	Remedy
1. Connection joints loose 2. Hose cracked 3. Piston seal worn	1. Tighten joint 2. Replace hose 3. Replace brake caliper

Suspension

The following suspension system components should be inspected periodically to ensure proper operation.

- A. Shock absorber rods not bent, pitted, or damaged.
- B. Rubber damper not cracked, broken, or missing.
- C. Shock absorber body not damaged, punctured, or leaking.
- D. Shock absorber eyelets not broken, bent, or cracked.
- E. Shock absorber eyelet bushings not worn, deteriorated, cracked, or missing.
- F. Shock absorber spring not broken or sagging.

Shock Absorbers

REMOVING

1. Secure the ATV on a support stand to elevate the wheels and to release load on the suspension.

WARNING

Make sure the ATV is solidly supported on the support stand to avoid injury.

2. Remove the two cap screws and nuts securing each front shock absorber to the frame and the upper A-arm. Account for bushings and sleeves from each.

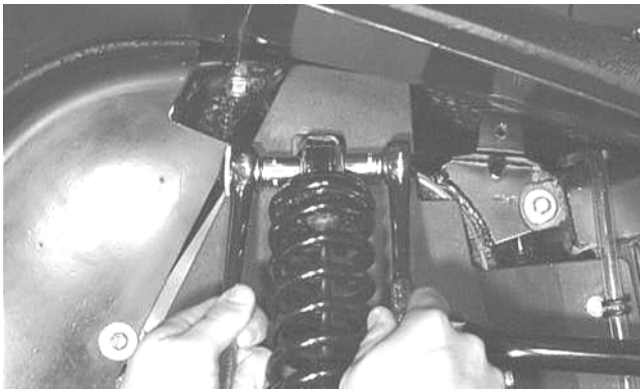

AF605D

CAUTION

Additional support stands are necessary to support the rear axle when the shock absorbers are removed or damage may occur.

3. Remove the two cap screws and nut securing each rear shock absorber to the frame and lower A-arm. Account for bushings and sleeves from each.



AF626D

4. Compress the shock absorber spring, remove the retainer, and remove the spring.



AF730D

CLEANING AND INSPECTING

NOTE: Whenever a part is worn excessively, cracked, or damaged in any way, replacement is necessary.

1. Thoroughly clean all shock absorber components.
2. Inspect each shock rod for nicks, pits, rust, bends, and oily residue.
3. Inspect all springs, spring retainers, shock rods, sleeves, bushings, shock bodies, and eyelets for cracks, leaks, and bends.

INSTALLING

1. Place the shock absorber spring over the shock absorber, compress the spring, and install the retainer.
2. Place bushings and sleeves (where appropriate) into shock eyelet; then install shock with two cap screws and nuts. Tighten all front and upper rear nuts to 50 ft-lb and the lower rear A-arm nuts to 20 ft-lb.

CAUTION

Do not tighten the lower shock to A-arm nuts beyond the 20 ft-lb specification or the shock eyelet or mount WILL be damaged.

3. Remove the ATV from the support stand.

Front A-Arms

REMOVING

1. Secure the ATV on a support stand to elevate the front wheels; then remove the wheels.

WARNING

Make sure the ATV is solidly supported on the support stand to avoid injury.

2. Remove the cotter pin from the nut. Discard the cotter pin.



CD008

3. Remove the nut securing the hub.
4. Remove the brake caliper.

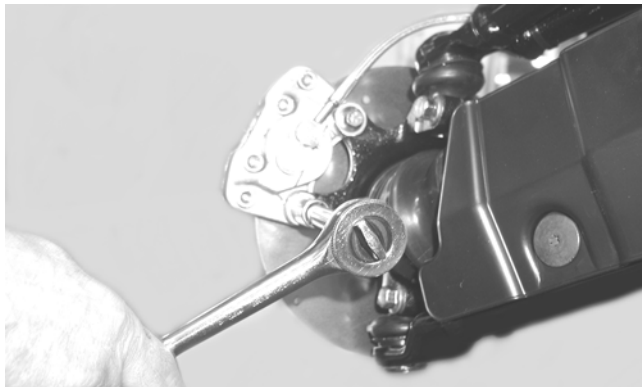

CD007

5. Remove the hub assembly.
6. Remove the cotter pin and slotted nut securing the tie rod end to the knuckle; then remove the tie rod end from the knuckle.

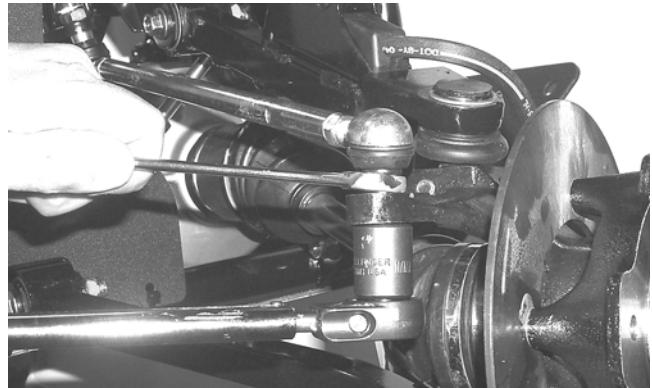

AF618D

7. Remove the cap screws securing the ball joints to the knuckle.

CAUTION

Support the knuckle when removing the cap screws or damage to the threads will occur.

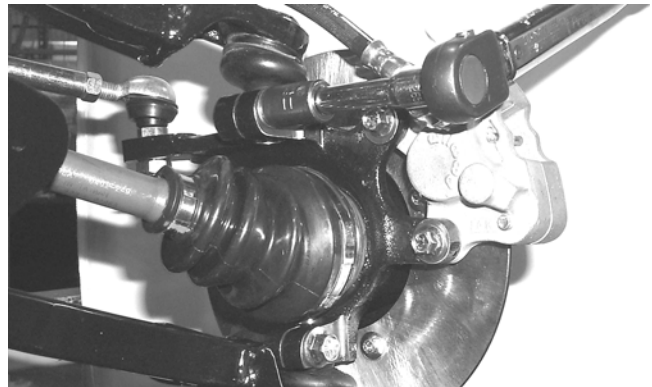

AF628D

8. Tap the ball joints out of the knuckle; then remove the knuckle.
9. Remove the lower shock absorber eyelet from the upper A-arm.
10. Remove the cap screws securing the A-arms to the frame.

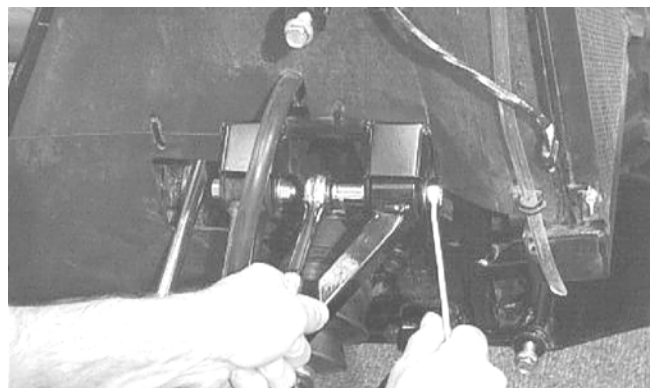

AF610D

11. Remove the snap ring from the ball joint; then remove the ball joint from the A-arm.

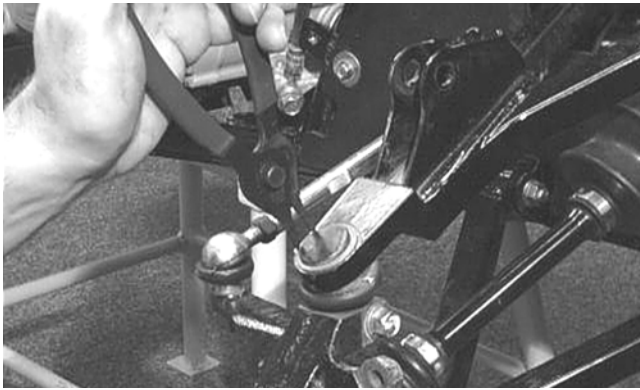

AF616D

CLEANING AND INSPECTING

■NOTE: Whenever a part is worn excessively, cracked, or damaged in any way, replacement is necessary.

1. Thoroughly clean all A-arm components using a pressure washer.
2. Clean the ball joint mounting hole of all residual Loctite, grease, oil, or dirt for installing purposes.
3. Inspect the A-arm for bends, cracks, and worn bushings.
4. Inspect the ball joint mounting holes for cracks or damage.
5. Inspect the frame mounts for signs of damage, wear, or weldment damage.

INSTALLING

1. Apply green Loctite #609 to the entire outside diameter of the ball joint; then install the ball joint into the A-arm and secure with the snap ring.



AF616D

2. Install the A-arm assemblies into the frame mounts and secure with the cap screws. Only finger-tighten at this time.

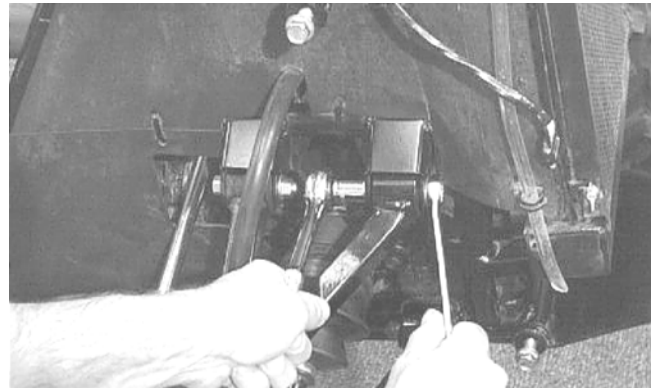

AF610D

3. Route the brake hose through the upper A-arm shock absorber mount; then secure the hose to the A-arm with the routing clamp.

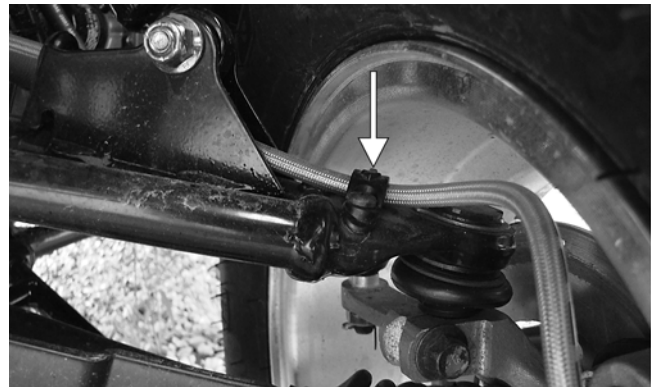

DE679A

4. Secure the lower eyelet of the shock absorber to the upper A-arm. Tighten nut to 50 ft-lb.
5. Secure the A-arm assemblies to the frame mounts (from step 2). Tighten the cap screws to 50 ft-lb
6. Install the knuckle assembly onto the ball joints and secure with cap screws. Tighten to 35 ft-lb.

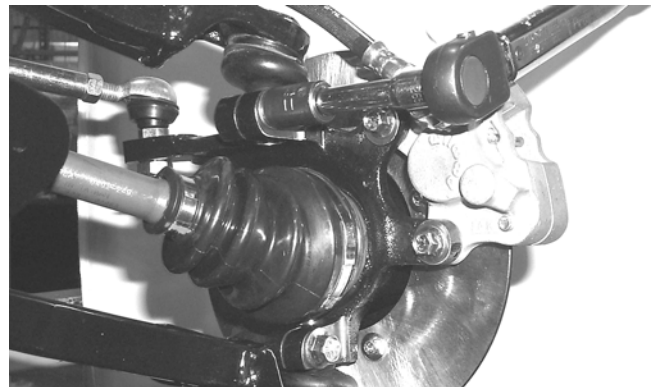

AF628D

7. Install the tie rod end and secure with the nut. Tighten to 35 ft-lb; then install a new cotter pin and spread the pin to secure the nut.

■NOTE: During assembly, new cotter pins should be installed.

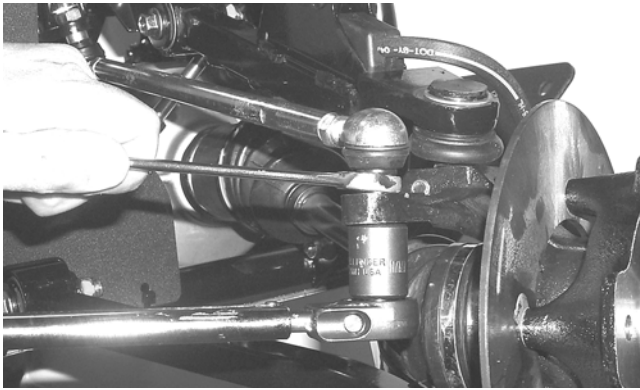

AF618D

- Apply grease to the hub and drive axle splines; then install the hub assembly onto the drive axle.

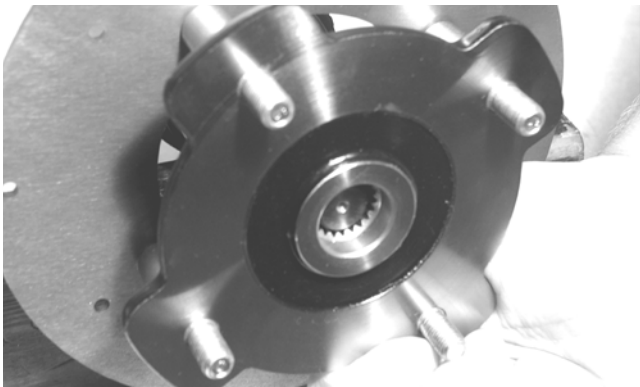

CD009

- Secure the hub assembly with the nut. Tighten only until snug.
- Secure the brake caliper to the knuckle with new "patch-lock" cap screws. Tighten to 20 ft-lb.

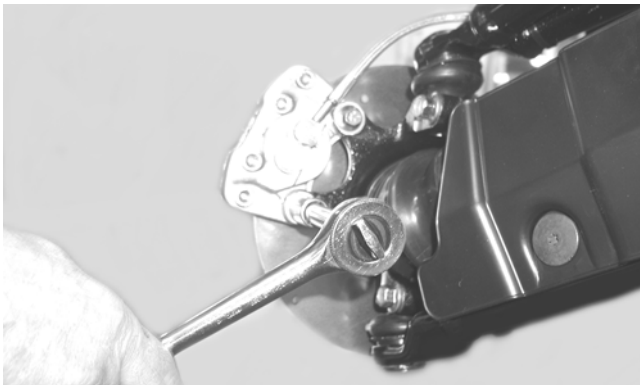

CD007

- Tighten the hub nut (from step 9) to 200 ft-lb.
- Install a new cotter pin and spread the pin to secure the nut.

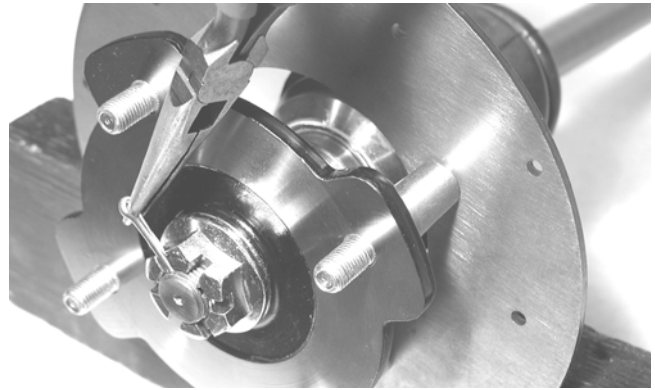

CD008

- Install the wheel and tighten to 45 ft-lb (steel wheels) or 80 ft-lb (aluminum wheels).
- Remove the ATV from the support stand.

Rear A-Arms

REMOVING

- Secure the ATV on a support stand to elevate the wheels.

⚠ WARNING

Make sure the ATV is solidly supported on the support stand to avoid injury.

- Pump up the hand brake; then engage the brake lever lock.
- Remove the wheel.
- Remove the cotter pin securing the hex nut; then remove the hex nut. Release the brake lever lock.
- Remove the caliper (right side only).

NOTE: Do not allow the brake calipers to hang from their cable/hose.

- Remove the cap screws and lock nut securing the shock absorber to the frame and lower A-arm; then remove the shock absorber.
- Remove the cap screws securing the boot guard to the lower A-arm.



AF934

- Slide the hub out of the knuckle and set aside.

- Remove the cap screws and lock nuts securing the knuckle to the A-arms. Discard the lock nuts.

NOTE: Never reuse a lock nut. Once a lock nut has been removed, it must be replaced with a new lock nut.

- Remove the cap screws and lock nuts securing the A-arms to the frame; then remove the A-arms.

NOTE: If removing the upper right A-arm, it will be necessary to disconnect the brake hose from the A-arm.

CLEANING AND INSPECTING

NOTE: Whenever a part is worn excessively, cracked, or damaged in any way, replacement is necessary.

- Thoroughly clean all A-arm components using a pressure washer.
- Inspect the A-arm for bends, cracks, and worn bushings.
- Inspect the frame mounts for signs of damage, wear, or weldment damage.

INSTALLING

- Install the A-arm assemblies into the frame mounts and secure with the cap screws and new lock nuts. Only finger-tighten at this time.
- Slide the knuckle onto the drive axle and into position on the A-arms; then secure the knuckle to the A-arms with cap screws and new lock nuts. Tighten to 50 ft-lb.
- Tighten the hardware securing the A-arms to the frame mounts (from step 1) to 50 ft-lb.
- Apply grease on the drive axle splines; then install the hub assembly onto the drive axle.

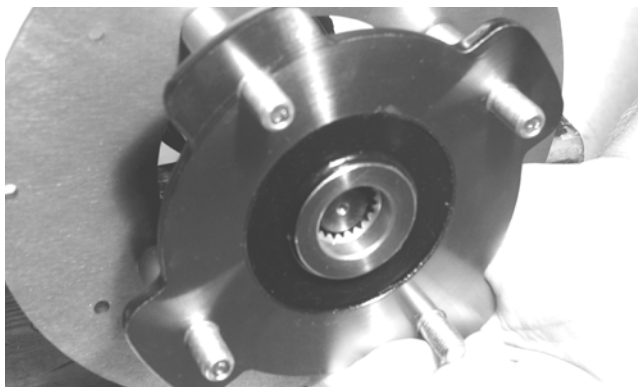

CD009

- Secure the hub assembly with the nut. Tighten only until snug.
- Secure the brake caliper to the knuckle with new “patch-lock” cap screws (right side only). Tighten the caliper to 20 ft-lb.

NOTE: Ensure that the brake hose is properly routed and secured to the upper A-arm with the brake hose clips.

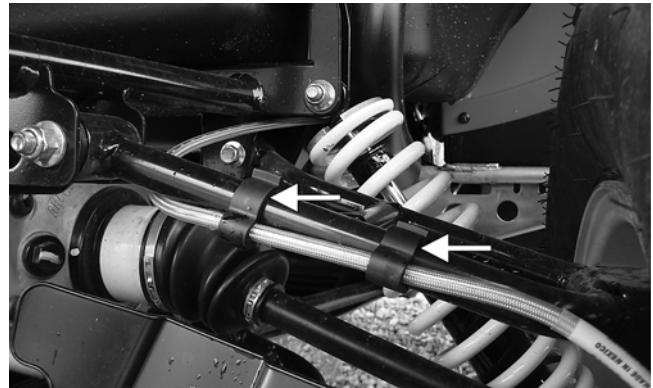

DE680A

- Compress the hand brake lever and engage the brake lever lock; then secure the hub nut (from step 5) to the drive axle. Tighten to 200 ft-lb.
- Install a new cotter pin and spread the pin to secure the nut.

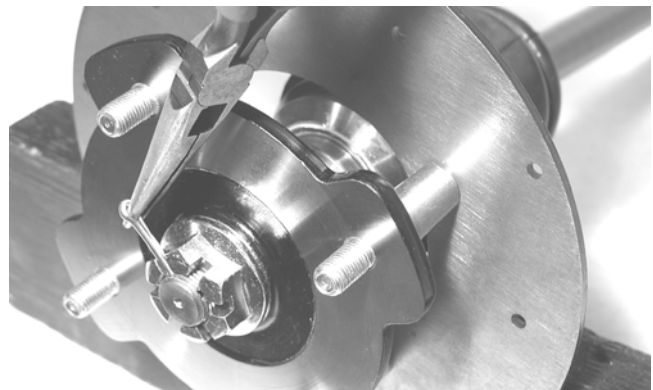

CD008

- Secure the shock absorber to the frame with a cap screw and new lock nut. Tighten to 50 ft-lb.
- Secure the shock absorber to the lower A-arm with a cap screw and new lock nut. Tighten to 20 ft-lb.
- Secure the boot guard to the lower A-arm with the two cap screws. Tighten securely.
- Install the wheel and tighten to 45 ft-lb (steel wheels) or 80 ft-lb (aluminum wheels).
- Remove the ATV from the support stand.

Wheels and Tires

TIRE SIZE

⚠ WARNING

Use only Arctic Cat approved tires when replacing tires. Failure to do so could result in unstable ATV operation.

The ATV is equipped with low-pressure tubeless tires of the size and type listed in the General Information section. Do not under any circumstances substitute tires of a different type or size.

⚠ WARNING

Do not mix tire tread patterns. Use the same pattern type on front and rear. Failure to heed warning could cause poor handling qualities of the ATV and could cause excessive drive train damage not covered by warranty.

TIRE INFLATION PRESSURE

Front and rear tire inflation pressure should be 0.35 kg/cm² (5.0 psi).

REMOVING

1. Secure the ATV on a support stand to elevate the wheels.

⚠ WARNING

Make sure the ATV is solidly supported on the support stand to avoid injury.

2. Remove the wheels.

■NOTE: Keep left-side and right-side wheels separated for installing them on their proper sides.

CLEANING AND INSPECTING

■NOTE: Whenever a part is worn excessively, cracked, or damaged in any way, replacement is necessary.

1. Thoroughly clean the wheels and hubs using a pressure washer.
2. Clean the tires with soap and water.
3. Inspect each wheel for cracks, dents, or bends.
4. Inspect each tire for cuts, wear, missing lugs, and leaks.

INSTALLING

Install each wheel on its hub. Tighten to 45 ft-lb (steel wheels) or 80 ft-lb (aluminum wheels).

■NOTE: Make sure each wheel is installed on its proper hub as noted in removing (the “rotation arrow” (if applicable) must indicate forward direction of rotation).



AF612D

CHECKING/INFLATING

1. Using an air pressure gauge, measure the air pressure in each tire. Adjust the air pressure as necessary to meet the recommended inflation pressure.



CD005

2. Inspect the tires for damage, wear, or punctures.

⚠ WARNING

Do not operate the ATV if tire damage exists.

■NOTE: If repair is needed, follow the instructions found on the tire repair kit or remove the wheel and have it repaired professionally.

■NOTE: Be sure all tires are the specified size and have identical tread pattern.

3. Check the front wheel toe-in and adjust as necessary (see Steering/Frame).
4. Test drive the ATV on a dry, level surface and note any pulling to the left or right during acceleration, deceleration, and braking.

■NOTE: If pulling is noted, measure the circumference of the front and rear tires on the pulling side. Compare the measurements with the tires on the opposite side. If pulling is noted during braking only, check and adjust the brakes as necessary and recheck operation (see Periodic Maintenance/Tune-Up).

5. Increase the air pressure in the tires with the smallest circumference measurement until all tires are equal in circumference.
6. Repeat steps 4-5 as necessary to ensure proper handling.

Troubleshooting

Problem: Suspension too soft	
Condition	Remedy
1. Spring(s) weak 2. Shock absorber damaged 3. Shock absorber preload too low	1. Replace spring(s) 2. Replace shock absorber 3. Adjust shock absorber preload
Problem: Suspension too stiff	
Condition	Remedy
1. A-arm-related bushings worn 2. Shock absorber preload too high	1. Replace bushing 2. Adjust shock absorber preload
Problem: Suspension noisy	
Condition	Remedy
1. Cap screws (suspension system) loose 2. A-arm-related bushings worn	1. Tighten cap screws 2. Replace bushings

Steering/Frame/Controls

The following steering components should be inspected periodically to ensure safe and proper operation.

- A. Handlebar grips not worn, broken, or loose.
- B. Handlebar not bent, cracked, and has equal and complete full-left and full-right capability.
- C. Steering post bearing assembly/bearing housing not broken, worn, or binding.
- D. Ball joints not worn, cracked, or damaged.
- E. Tie rods not bent or cracked.
- F. Knuckles not worn, cracked, or damaged.
- G. Cotter pins not damaged or missing.

Steering Post/Tie Rods

REMOVING

1. Remove the ignition switch retaining ring; then remove the reinstallable rivets securing the instrument pod to the mounting bracket and remove the pod.

■NOTE: It is not necessary to disconnect any wires from instrument pod components.

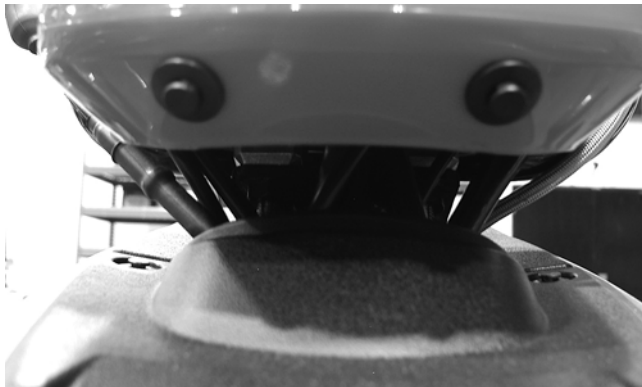

CD759

2. Remove the reinstallable rivets securing the radiator access cover and remove the cover.



CD666

3. Remove the reinstallable rivets securing the steering post cover and remove the cover.
4. Unlatch the storage compartment lid; then slide the storage compartment cover assembly forward and lift off.
5. Remove the four cap screws securing the handlebar caps and instrument pod bracket to the steering post; then move the handlebar out of the way. Account for four handlebar caps.
6. Remove two cap screws securing the upper steering post bearing to the frame. Account for two bearings and two housings.



CD760

7. Using a suitable lift stand, raise the ATV enough to remove the front wheels; then remove the left-side and right-side splash panels.

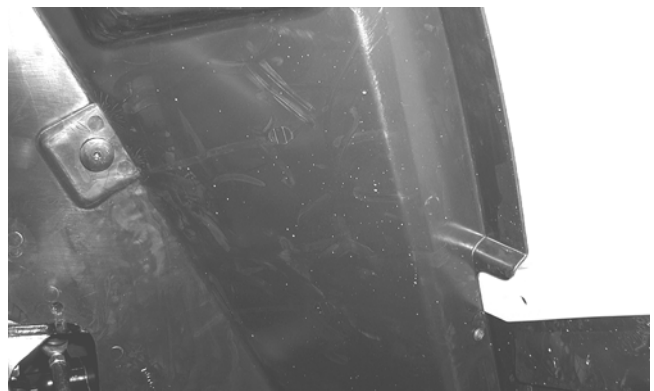

CD685

8. Remove the cotter pins and slotted nuts from the inner and outer tie rod ends; then remove the tie rods from the steering post arm and the left-side and right-side steering knuckles.

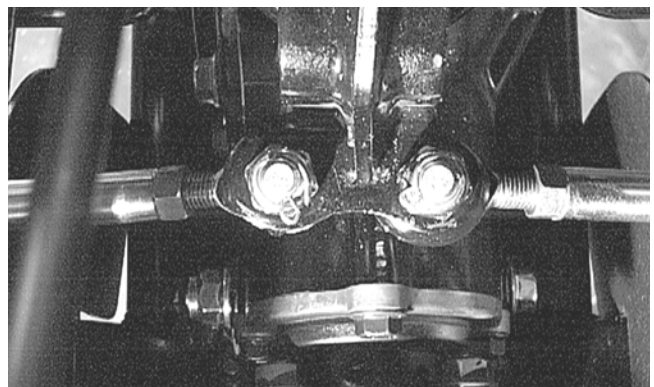

AF778D

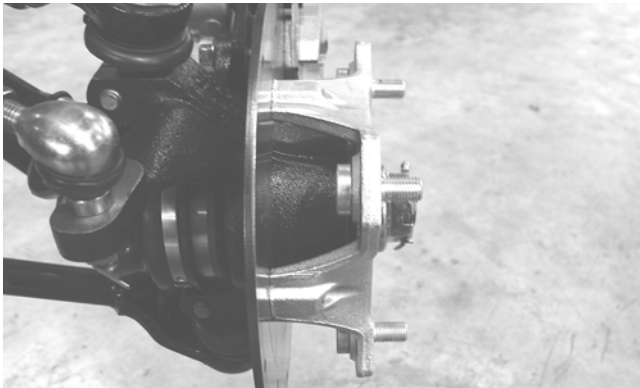

KX039

- Remove two cap screws securing the lower steering post bearing flange to the frame; then remove the steering post.

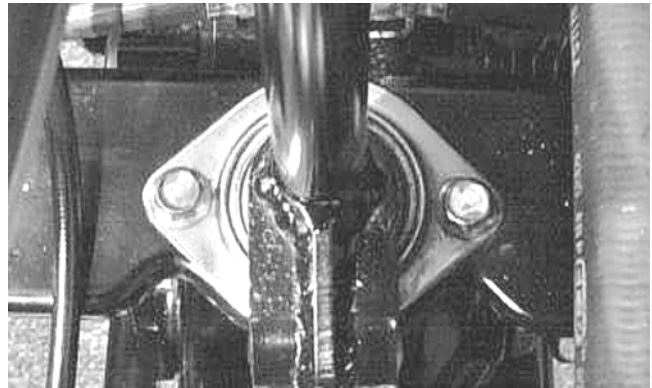

AL600D

- Place the upper steering post bearings into the housings; then position on the steering post and secure the housings to the frame with two cap screws. Tighten to 20 ft-lb.

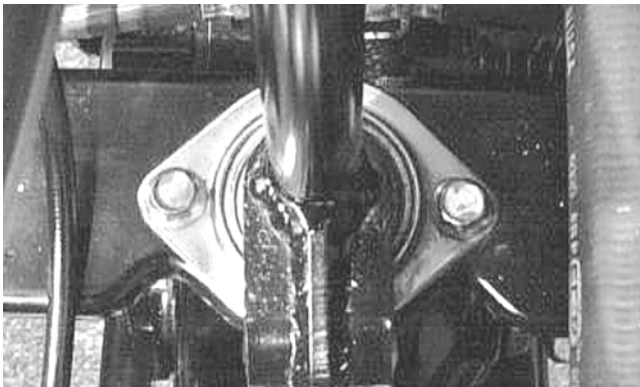

AL600D



CD760

- Install the tie rods and secure with the slotted nuts. Tighten to 35 ft-lb; then install new cotter pins.

CLEANING AND INSPECTING

■NOTE: Whenever a part is worn excessively, cracked, or damaged in any way, replacement is necessary.

- Wash the tie rod ends in parts-cleaning solvent. Dry with compressed air. Inspect the pivot area for wear. Apply a low-temperature grease to the ends.

⚠ WARNING

Always wear safety glasses when using compressed air.

- Inspect the tie rods for damaged threads or wear.
- Inspect the tie rods for cracks or unusual bends.
- Inspect all welded areas for cracks or deterioration.
- Inspect the steering post and steering-post brackets for cracks, bends, or wear.
- Inspect the bearing halves, bearing caps, and bearing housings for cracks or wear.
- Inspect the handlebar tube for cracks, wear, or unusual bends.
- Inspect the handlebar grips for damage or wear.

INSTALLING

- Place the steering post into position; then secure the lower bearing flange to the frame with two cap screws. Tighten to 20 ft-lb.

■NOTE: If the slots do not align with the holes in the tie rod ends, tighten the nuts just enough to allow installation of the cotter pins.

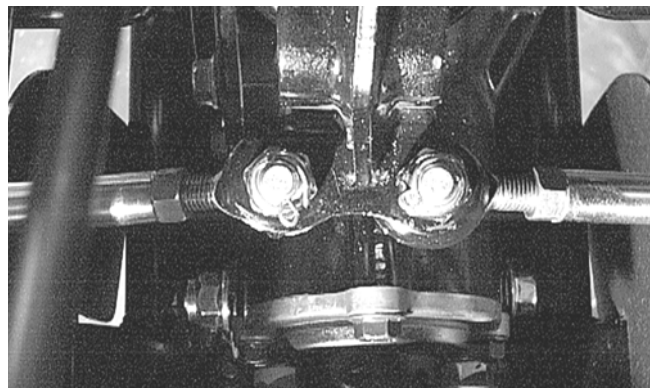

AF778D

- Install the splash panels; then install the front wheels and tighten to 45 ft-lb (steel wheels) or 80 ft-lb (aluminum wheels) using a crisscross pattern.
- Lower the ATV and place the handlebar and caps into position on the steering post; then position the instrument pod mounts on top of the caps and secure with the four cap screws. Tighten to 20 ft-lb.
- Place the instrument pod into position; then secure with reinstallable rivets and the ignition switch locking ring.



CD677

7. Install the steering post access cover and secure with reinstallable rivets; then install and secure the radiator access cover.

Handlebar Grip

REMOVING

1. Remove the plug and end-cap from the handlebar.
2. Using compressed air between the grip and the handlebar, twist the grip back and forth until it slides free of the handlebar.

INSPECTING

■NOTE: Whenever a part is worn excessively, cracked, or damaged in any way, replacement is necessary.

1. Inspect the grip for wear, cuts, or cracks.
2. Inspect the grip for deterioration.

INSTALLING

■NOTE: Before installing a grip, use contact spray or alcohol to clean the inside of the grip and the handlebar of glue residue, oil, or any other contaminant.

1. Apply a liberal amount of Handlebar Grip Adhesive to the inside of the grip.
2. Slide the grip onto the handlebar until it is fully seated with the smooth part of the grip facing up.
3. Wipe off any excess glue; then secure the grip with the handlebar plug and end-cap.

Hand Brake Lever/Master Cylinder Assembly

■NOTE: The master cylinder is a non-serviceable component; it must be replaced as an assembly.

REMOVING

1. Slide a piece of flexible tubing over one of the wheel bleeder valves and direct the other end into a container. Remove the reservoir cover; then open the bleeder valve. Allow the brake fluid to drain completely.

■NOTE: Compressing the brake lever several times will quicken the draining process.



AF637D

2. Place an absorbent towel around the connection to absorb brake fluid. Remove the banjo-fitting from the master cylinder. Account for two crush washers and a banjo-fitting bolt.

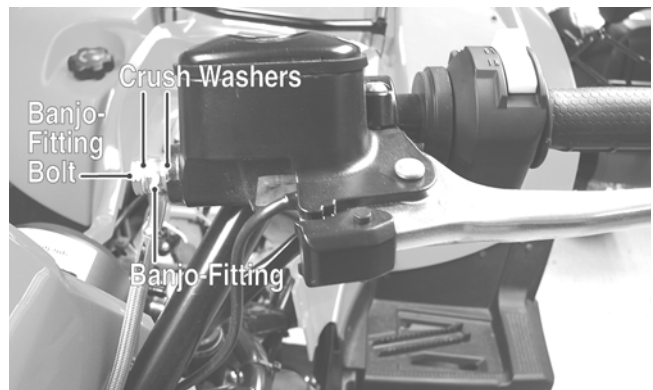

DE059A

CAUTION

Brake fluid is highly corrosive. Do not spill brake fluid on any surface of the ATV.

3. Remove the snap ring and pivot pin securing the brake lever to the master cylinder housing; then remove the brake lever and set aside.
4. Dislodge the brakelight switch from the master cylinder housing by gently pressing it toward the pivot pin hole in the housing; then lay it aside leaving the switch and wiring harness connected.

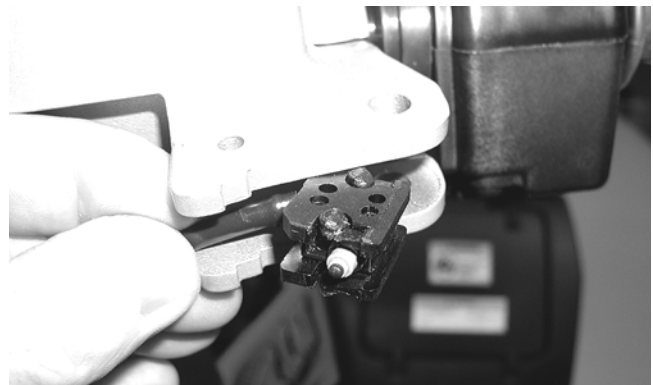

BC205

- Remove the clamp screws securing the brake housing to the handlebar; then remove the assembly from the handlebar.



DE058A

INSPECTING

■NOTE: Whenever a part is worn excessively, cracked, or damaged in any way, replacement is necessary.

- Inspect the pin securing the brake lever for wear.
- Inspect the brake lever for elongation of the pivot hole.
- Inspect the reservoir for cracks and leakage.
- Inspect the banjo-fitting for cracks and deterioration and the condition of the fittings (threaded and compression).
- Inspect the brakelight switch for corrosion, cracks, missing or broken mounting tabs, or broken and frayed wiring.

■NOTE: If the brakelight switch is determined to be not serviceable, see Electrical System.

INSTALLING

- Position the brake housing on the handlebar. Secure with clamp screws; then tighten securely.

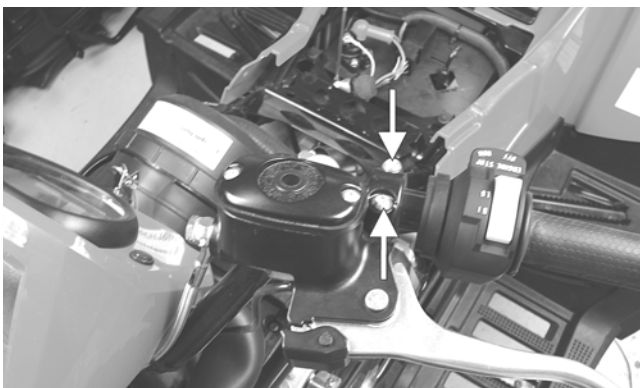

DE058A

- Using two new crush washers, connect the banjo-fitting to the master cylinder; then secure with the banjo-fitting bolt. Tighten to 20 ft-lb.

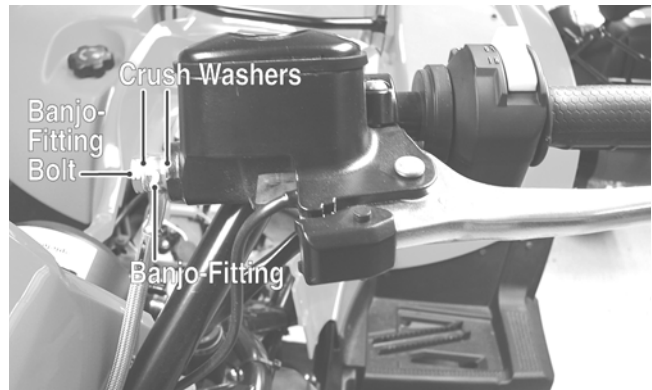

DE059A

- Gently press the brakelight switch into the housing (left to right) until the mounting tabs snap into the four locating holes; then install the brake lever, pivot pin, and snap ring.

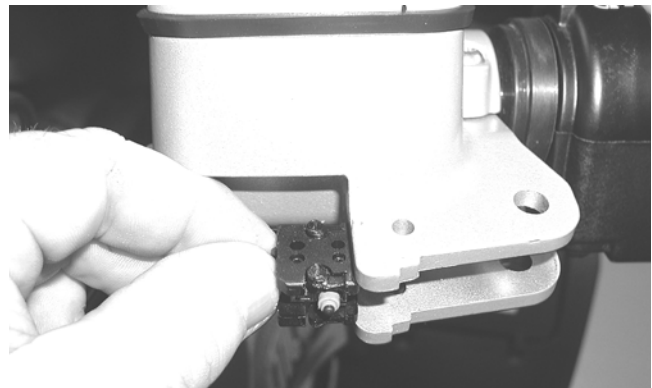

BC206

- Bleed the brake system (see Periodic Maintenance/Tune-Up).

Throttle Control

REMOVING

- Remove the two machine screws securing the throttle control to the handlebar.
- Slide the grommet out of the lower half of the throttle control; then remove the cable from the actuator arm.

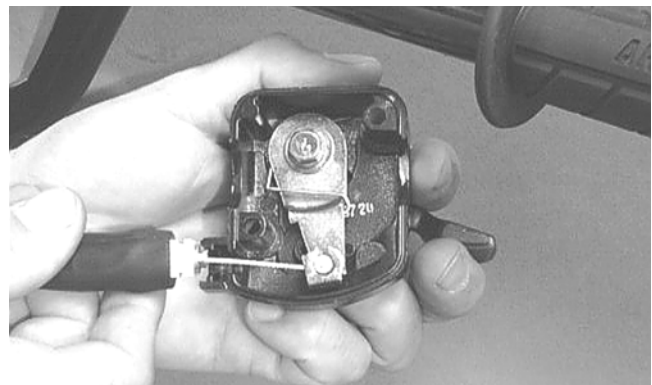

AF676D

- Remove the cap screw, lock washer, and washer securing the actuator arm to the throttle control lever.

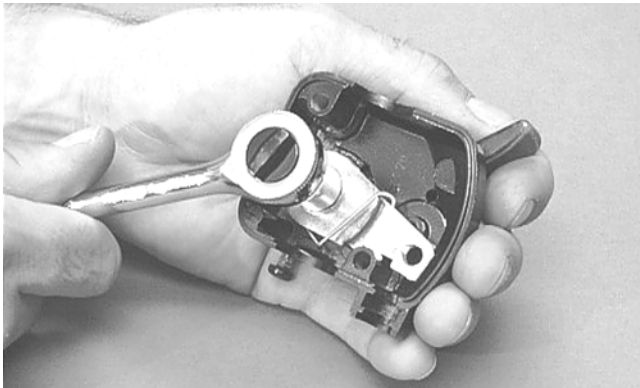

AF677D

4. Remove the actuator arm and account for a bushing. Note the position of the return spring for installing purposes.

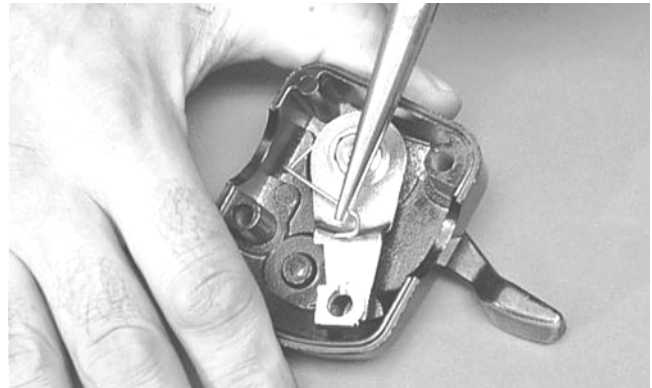

AF680D

3. Place the two halves of the throttle control onto the handlebars and secure with the two machine screws.

ADJUSTING

To adjust throttle cable free-play, see Periodic Maintenance/Tune-Up.

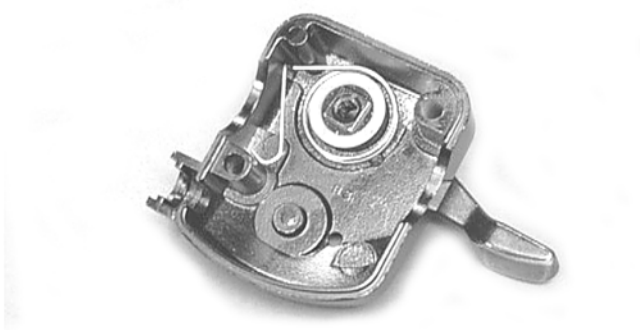

AF678D

INSTALLING

1. Place the return spring into the throttle control; then place the bushing and actuator arm into position. Secure with the cap screw, lock washer, and washer.

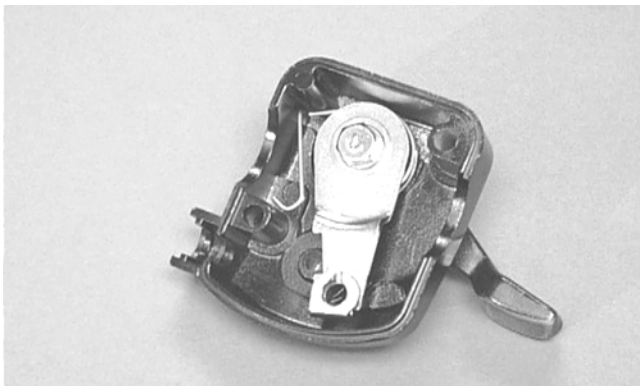

AF679D

2. Using a pair of needle-nose pliers, place the spring into position on the actuator arm.

Shift Lever

REMOVING

1. Remove the left-side splash panel.
2. Remove the E-clip securing the shift rod to the shift lever.
3. Remove the axle and nut securing the shift lever to the upper shift arm; then remove the shift lever. Account for a spring and two O-rings.

INSTALLING

1. Place the spring into position between the upper shift arm and shift lever; then making sure the O-rings are in place on the axle, secure the shift lever to the arm with the existing axle and nut.
2. Place the shift rod into position on the shift lever and secure with the existing E-clip.
3. Check shift lever adjustment (see Periodic Maintenance/Tune-Up section); then tighten jam nut(s) securely.
4. Install the left-side splash panel.

LCD Gauge

REPLACING

1. Remove the two reinstallable rivets securing the instrument pod; then remove the ignition switch retaining ring.
2. Remove the two nuts securing the mounting studs; then remove the speedometer from the instrument pod and disconnect the multi-pin connector.
3. Mount the speedometer in the instrument pod and secure with the two nuts; then connect the multi-pin connector.

4. Install the instrument pod and secure with the re-installable rivets.
5. Secure the ignition switch with the retaining ring.

Steering Knuckles

REMOVING AND DISASSEMBLING

1. Secure the ATV on a support stand to elevate the wheel; then remove the wheel.

WARNING

Make sure the ATV is solidly supported on the support stand to avoid injury.

2. Remove the wheel cap from the hub; then remove the cotter pin from the nut.
3. Remove the nut securing the hub.
4. Remove the brake caliper.
5. Remove the hub assembly.
6. Remove the cotter pin from the tie rod end and remove the tie rod end from the knuckle.
7. Remove the two cap screws securing the ball joints in the knuckle.
8. Tap the ball joint end out of the knuckle; then remove the knuckle.
9. Remove the snap ring from the knuckle; then remove the bearing.



PR287A



PR288

CAUTION

Use extreme care when removing the bearing. If the bearing is allowed to fall, it will be damaged and will have to be replaced.

CLEANING AND INSPECTING

■NOTE: Whenever a part is worn excessively, cracked, or damaged in any way, replacement is necessary.

1. Clean all knuckle components.
2. Inspect the bearing for pits, gouges, rusting, or premature wear.
3. Inspect the knuckle for cracks, breaks, or porosity.
4. Inspect threads for stripping or damage.

ASSEMBLING AND INSTALLING

1. Install the bearing; then install the snap ring making sure it seats into the knuckle.



PR287A

2. Install the knuckle to the upper and lower ball joints and secure with the two cap screws. Tighten to 35 ft-lb.

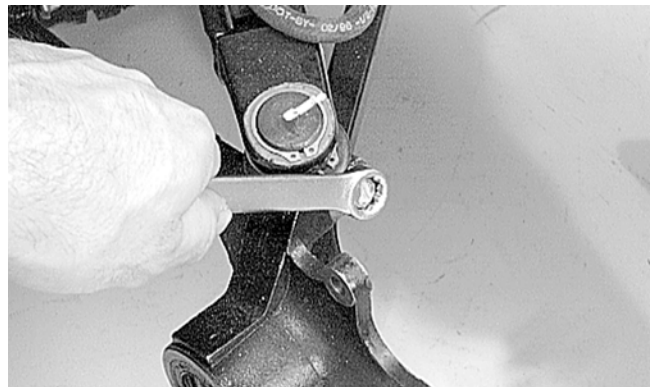

AF760D

3. Install the tie rod end and secure with the nut. Tighten to 35 ft-lb; then install a new cotter pin and spread the pin.

■NOTE: During assembling, new cotter pins should be installed.

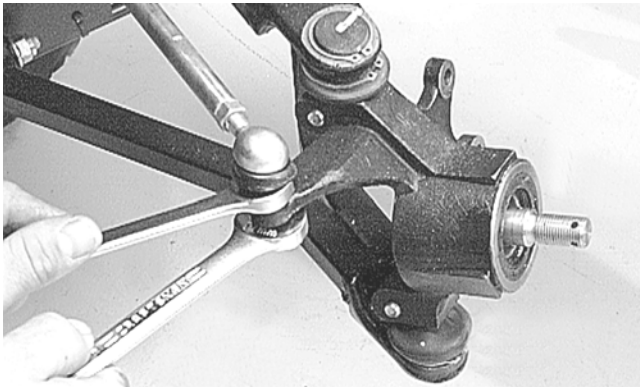

AF759D

4. Apply a small amount of grease to the hub splines.



PR290A

5. Install the hub assembly onto the splines of the shaft.

6. Secure the hub assembly with the nut. Tighten only until snug.

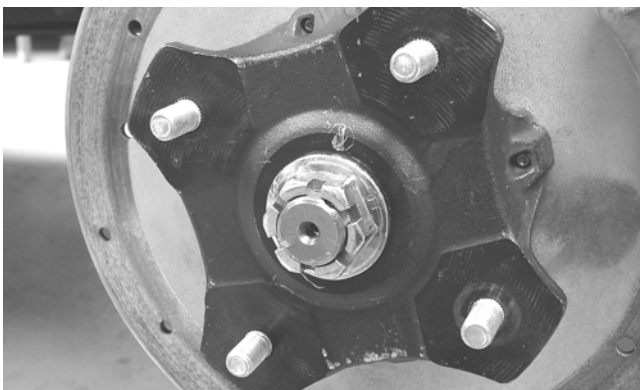

PR257

7. Secure the brake caliper to the knuckle with new "patch-lock" cap screws. Tighten to 20 ft-lb.

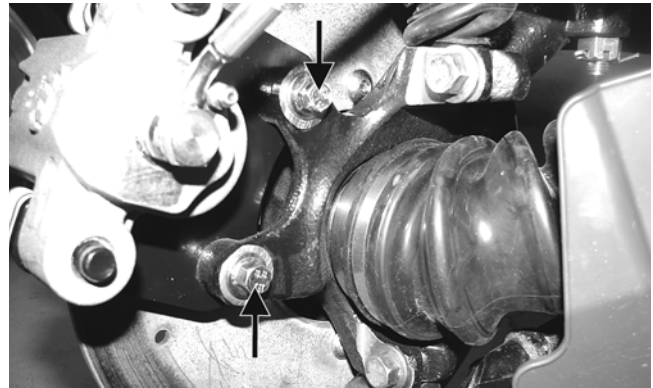

PR264A

8. Pump the hand brake lever; then engage the brake lever lock.

9. Tighten the hub nut (from step 6) to the shaft. Tighten to 200 ft-lb.

10. Install a new cotter pin and spread the pin to secure the nut.

11. Install the wheel; then using a crisscross pattern, tighten to 45 ft-lb (steel wheels) or 80 ft-lb (aluminum wheels).

12. Remove the ATV from the support stand.

Measuring/Adjusting Toe-In

1. Thoroughly wash the ATV to remove excess weight (mud, etc.).

2. Refer to the specifications and ensure the tires are properly inflated to the recommended pressure.

■NOTE: Ensure the inflation pressure is correct in the tires or inaccurate measurements can occur.



CD005

3. Place the ATV in a level position taking care not to push down or lift up on the front end; then turn the handlebar to the straight ahead position.

■NOTE: When measuring and adjusting, there should be a normal operating load on the ATV.

4. Measure the distance from the outside edge of each handlebar grip to equal reference points on each side.



DE047A

5. Adjust the handlebar direction until the two measurements are equal; then secure the handlebar to the rear rack using tie-down straps.

■NOTE: Care must be taken not to allow the handlebar to turn while securing it.



CD014

6. Measure the distance from the inside of each front rim to the lower frame tube.

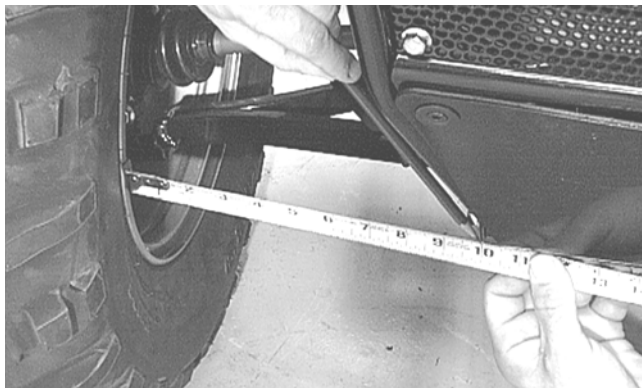

AF785D

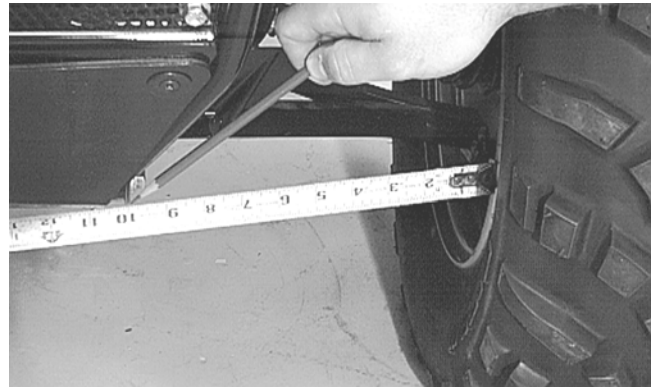

AF786D

■NOTE: The distances from the inside rims to the frame tubes should be equal. If the measurements are equal, proceed to step 8; if the measurements are not equal, proceed to step 7.

7. To make the measurements equal, loosen the appropriate tie rod jam nuts and adjust accordingly; then proceed to step 8.

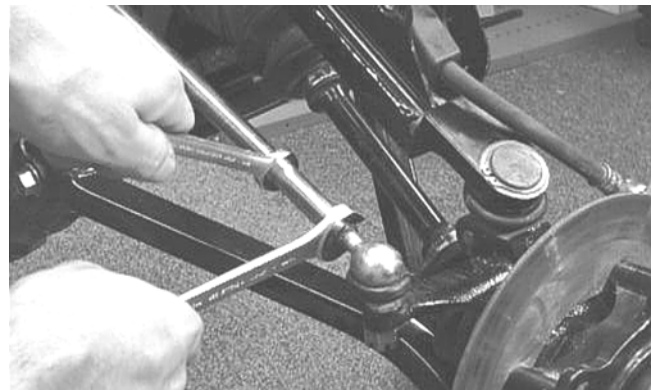

AF617D

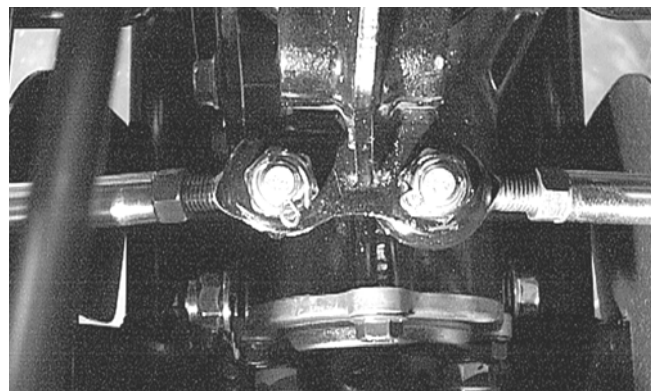

AF778D

■NOTE: The front wheels do not have to be removed to adjust the tie rod. Also, care should be taken not to disturb the handlebar position.

8. Using a permanent marker of some type, mark the center of each front tire (at a height parallel to the belly panel).



AF789D

9. Measure the distance between the marks (at a height parallel to the belly panel) at the front side; then record the measurement.
10. Push the ATV forward until the marks are parallel to the belly panel on the back side; then measure the distance between the marks.
11. The difference in the measurements must show 3.2-6.4 mm (1/8-1/4 in.) toe-in (the front measurement 3.2-6.4 mm (1/8-1/4 in.) less than the rear measurement).
12. If the difference in the measurements is not within specifications, adjust both tie rods equally until within specifications.

■NOTE: Prior to locking the jam nuts, make sure the ball joints are at the center of their normal range of motion and at the correct angle.

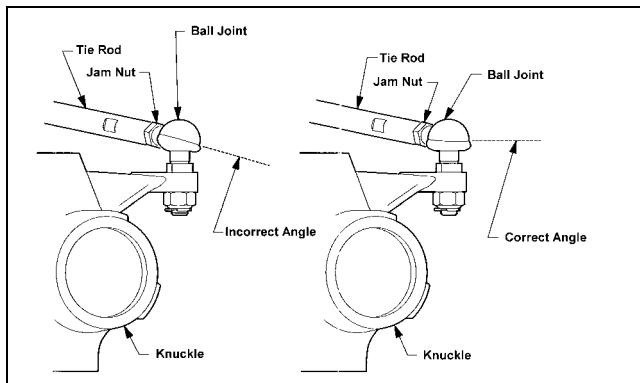

733-559A

Front Rack

REMOVING

1. Remove the two shoulder screws and lock nuts securing the front fender panel.
2. Remove the cap screws and lock nuts securing the rack to the frame.
3. Remove the front rack from the ATV.

CLEANING AND INSPECTING

■NOTE: Whenever a part is worn excessively, cracked, or damaged in any way, replacement is necessary.

1. Clean all rack components.
2. Inspect all welds for cracking or bending.
3. Inspect threaded areas of all mounting bosses for stripping.
4. Inspect for missing decals and/or reflectors.

INSTALLING

1. Place the rack into position on the frame and front fender panel. Install the cap screws and lock nuts and finger-tighten only.
2. Install the two shoulder screws and lock nuts securing the rack to the fenders. Tighten all hardware securely.

Front Bumper Assembly

REMOVING

1. Remove the two flange bolts and lock nuts securing the upper bumper supports to the bumper.
2. Remove the through-bolt and lock nut securing the bumper to the frame; then remove the bumper.

CLEANING AND INSPECTING

■NOTE: Whenever a part is worn excessively, cracked, or damaged in any way, replacement is necessary.

1. Clean all bumper components.
2. Inspect all welds for cracking or bending.

INSTALLING

1. Place the front bumper assembly into position and install the through-bolt. Start the lock nut and finger-tighten only.
2. Install the two flange bolts and lock nuts on the upper supports. Tighten all hardware securely.

Front Body Panel/Side Panels

REMOVING

1. Remove the reinstallable rivets securing the radiator access cover and remove the cover; then remove the reinstallable rivets securing the steering post cover and remove the cover.

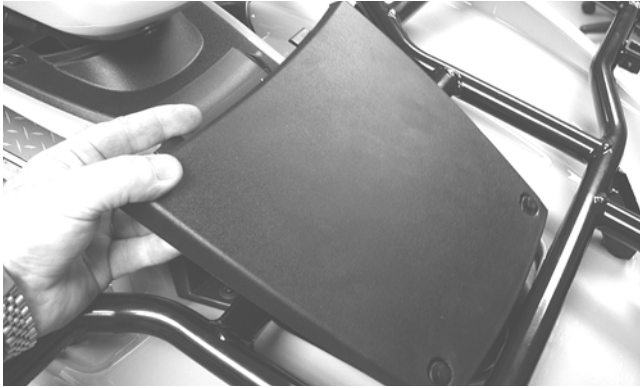

CD666

2. Remove the seat.
3. Remove the cap screws, shoulder screws, and lock nuts securing the front rack to the frame; then remove the front rack. Account for the grommets and bushings.
4. Remove three reinstallable rivets securing the right side panel; then remove the cap screws securing the rear of the front panel to the frame.



CD691



CD682

7. Remove the shift knob retaining pin and remove the shift knob; then remove the shift lever pivot axle nut and remove the axle and shift lever. Account for a spring and two O-rings.

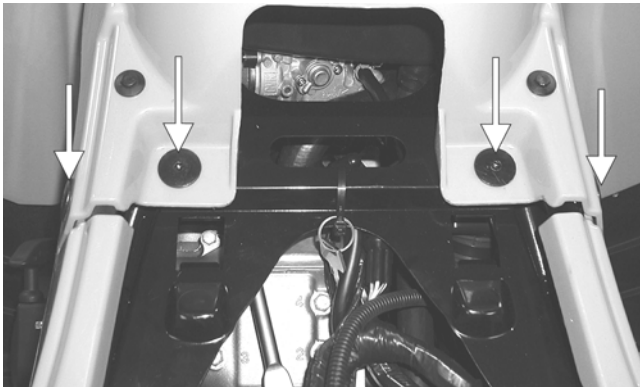

CD684A

5. Remove the cap screws and nylon ties securing the left-side and right-side splash panels; then remove the panels.

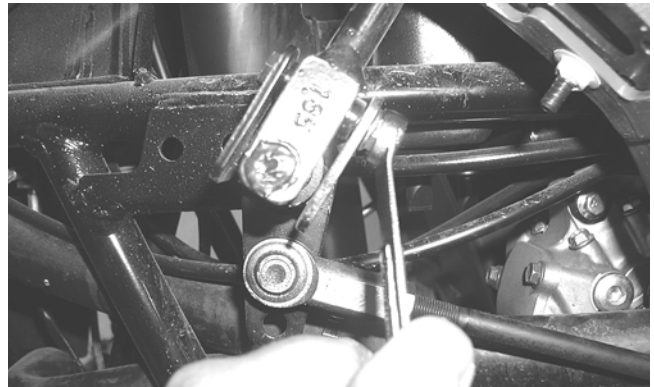

CD779

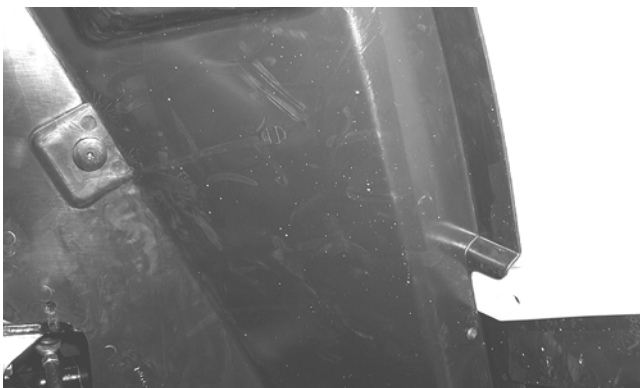

CD685

6. Remove one shoulder screw and four plastic rivets on each side to separate the front panel lower fenders from the left-side and right-side footwells.

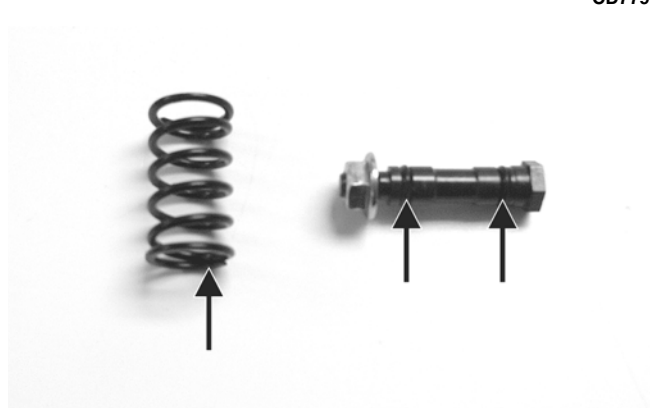

CD780A

8. Disconnect four headlight connectors and secure the wires out of the way; then disconnect the wires to the front accessory plug.



CD681

9. Rotate the handlebar to the full-left position; then lift and slide the panel to the rear and lift the rear up to clear the handlebar.



CD765

2. Connect the headlight connectors to the appropriate headlights and the front accessory plug wires to the accessory plug.



CD765A

■NOTE: It may be necessary to rotate the body panel to the right to align the opening with the handlebar.

CLEANING AND INSPECTING

■NOTE: Whenever a part is worn excessively, cracked, or damaged in any way, replacement is necessary.

1. Clean all fender components with a warm soap and water solution.
2. Inspect fenders for cracks and/or loose rivets.
3. Inspect for any missing decals.

INSTALLING

1. Rotate the handlebar to the full-left position; then place the front body panel over the handlebar and rotate and lower into position.



CD681

3. Make sure the rubber grommets and bushings are in place; then place the front rack into position and secure with the screws and flange nuts. Tighten securely.
4. Install one cap screw and flange nut and four plastic rivets on each side to secure the front fenders to the footwells. Tighten the flange nuts securely.

■NOTE: If the footwells have been removed, see Footrests in this section.

5. Install four cap screws securing the front body panel to the frame and rear panel.

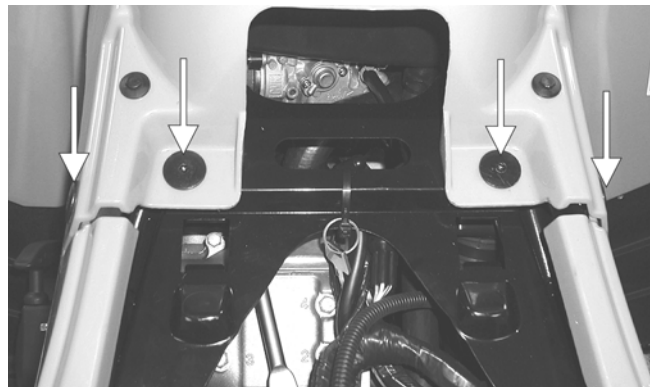

CD684A

6. Install the shift lever spring, shift lever, and pivot axle; then tighten the axle nut securely.

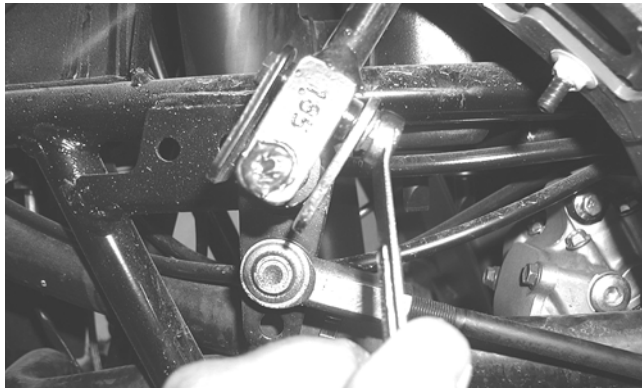

CD779

7. Install the left-side and right-side splash panels and tighten the cap screws securely. Install new nylon ties in the appropriate locations.
8. Install the instrument pod and ignition switch; then secure with two reinstallable rivets and the ignition switch lock collar.
9. Install the steering post cover and secure with the reinstallable rivets; then install and secure the radiator access panel.
10. Install the left-side and right-side engine covers.

Footrests

REMOVING

1. Remove the machine screws and flange nuts securing the front and rear fenders to the footwells.



CD691A

2. Remove the cap screws securing the foot pegs to the footrests; then remove the foot pegs and footwells.



CD782

3. Remove the cap screws and flange nuts securing the footrests to the frame; then remove the footrests.

CLEANING AND INSPECTING

■NOTE: Whenever a part is worn excessively, cracked, or damaged in any way, replacement is necessary.

1. Clean the footrest using a pressure washer.
2. Inspect the footrest weldments for cracks or unusual bends.
3. Inspect all tubing for cracks or unusual bends.

INSTALLING

1. Secure the footrests to the frame with four cap screws and two flange nuts; then tighten securely.
2. Place the footwells onto the footrests; then put the foot pegs in position and secure with two cap screws.
3. Install the machine screws and flange nuts securing the front and rear fenders to the footwells.

Belly Panel

REMOVING/INSTALLING

1. Remove the machine screws and shoulder washers securing the belly panel to the underside of the frame; then remove the belly panel.
2. Place the belly panel into position on the underside of the frame; then install the machine screws and shoulder washers. Tighten securely.

Exhaust System

REMOVING MUFFLER

1. Remove the two exhaust springs at the muffler/exhaust pipe juncture.

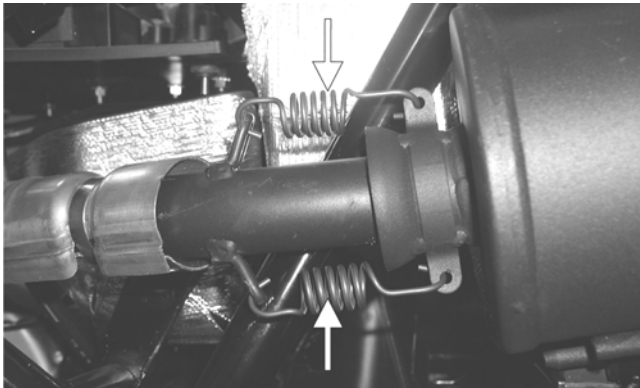

CF138A

2. Slide the muffler rearward to clear the mounting lugs and remove the muffler.

INSPECTING MUFFLER

■NOTE: Whenever a part is worn excessively, cracked, or damaged in any way, replacement is necessary.

1. Inspect muffler externally for cracks, holes, and dents.
2. Inspect the muffler internally by shaking the muffler back and forth and listening for rattles or loose debris inside the muffler.

■NOTE: For details on cleaning the muffler/spark arrester, see Periodic Maintenance/Tune-Up.

INSTALLING MUFFLER

1. Place the muffler into position engaging the mounting lugs into the grommets; then slide the muffler forward.
2. Install the two exhaust springs.

Rear Body Panel/Rack

REMOVING

1. Remove four cap screws and flanged nuts securing the rear rack; then remove the shoulder screws and lock nuts. Remove the rear rack. Account for the bushings.



CD690A

2. Remove one shoulder screw and lock nut and three plastic rivets (on each side) securing the rear body panel to the footwells.



CD691A

3. Remove two machine screws securing the tool tray.
4. Disconnect the battery (negative cable first).

■NOTE: The battery does not have to be removed to remove the rear body panel.

5. Disconnect the taillight/brakelight; then remove the fuel tank cap and lift off the rear body panel. Install the fuel tank cap.

■NOTE: If the front body panel has not been removed, the left-side and right-side panels and the two machine screws must be removed (see Front Body Panel/Side Panels in this section).

CLEANING AND INSPECTING

■NOTE: Whenever a part is worn excessively, cracked, or damaged in any way, replacement is necessary.

1. Clean all rear body panel components with a warm soap and water solution.
2. Inspect side panels and rear body panel for cracks and loose rivets.
3. Inspect threaded areas of all mounting bosses for stripping.
4. Inspect for missing decals.

INSTALLING

1. Remove the gas tank cap and set the rear body panel in position; then install the cap and connect the taillight/brakelight connector.
2. Place the rear rack in position with four bushings and secure with four cap screws, shoulder screws, and flanged nuts. Tighten securely.



CD690A

3. Install one shoulder screw and three plastic rivets (on each side) to secure the front of the rear body panel to the footwells.



CD691

4. Connect the battery (positive cable first).
5. Secure the front and rear panels with two machine screws; then install the left and right side panels.

■NOTE: If the front body panel has not been installed, see Front Body Panel/Side Panels in this section.

6. Place the seat into position making sure it locks securely.

Adjusting Headlight

The headlights can be adjusted vertically and horizontally. The geometric center of the HIGH beam light zone is to be used for vertical and horizontal aiming.

To check/adjust headlight beam, see Periodic Maintenance/Tune-Up.

⚠ WARNING

Do not operate the ATV unless the headlight beam is adjusted properly. An incorrectly adjusted beam will not provide the operator the optimum amount of light.

Taillight Assembly

REMOVING

1. Unplug the three-prong connector and free the tail-light wiring harness from the frame.
2. Remove the torx-head cap screws securing the tail-light assembly to the frame. Account for any washers.
3. Remove the taillight assembly.

INSPECTING

■NOTE: Whenever a part is worn excessively, cracked, or damaged in any way, replacement is necessary.

1. Inspect wiring harness, three-prong connector, lens, base, cap screws, and socket for damage.
2. Inspect all wires for corroding, pinching, and cracking.
3. Inspect the bulb for wattage, voltage, and proper operation.

INSTALLING

1. Place the assembly into position on the frame and secure with torx-head cap screws and any washers.
2. Tighten the cap screws securely.
3. Route the wiring harness over the rear frame; then connect the three-prong connector.

Seat

REMOVING/INSTALLING

1. To remove the seat, lift up on the latch release (located at the rear of the seat). Raise the rear of the seat and slide it rearward.
2. To lock the seat into position, slide the front of the seat into the seat retainers and push down firmly on the rear of seat. The seat should automatically lock into position.

Troubleshooting

Problem: Handling too heavy or stiff	
Condition	Remedy
<ol style="list-style-type: none"> 1. Front wheel alignment incorrect 2. Lubrication inadequate 3. Tire inflation pressure low 4. Tie rod ends seizing 5. Linkage connections seizing 	<ol style="list-style-type: none"> 1. Adjust alignment 2. Lubricate appropriate components 3. Adjust pressure 4. Replace tie rod ends 5. Repair - replace connections
Problem: Steering oscillation	
Condition	Remedy
<ol style="list-style-type: none"> 1. Tires inflated unequally 2. Wheel(s) bent 3. Wheel lug nut(s) loose - missing 4. Wheel hub bearing worn - damaged 5. Tie rod ends worn - loose 6. Tires defective - incorrect 7. A-arm bushings damaged 8. Bolts - nuts (frame) loose 9. Wheel stud(s) loose - missing 	<ol style="list-style-type: none"> 1. Adjust pressure 2. Replace wheel(s) 3. Replace lug nut(s) 4. Replace bearing 5. Replace - tighten tie rod ends 6. Replace tires 7. Replace bushings 8. Tighten bolts - nuts 9. Replace wheel studs
Problem: Steering pulling to one side	
Condition	Remedy
<ol style="list-style-type: none"> 1. Tires inflated unequally 2. Front wheel alignment incorrect 3. Wheel hub bearings worn - broken 4. Frame distorted 5. Shock absorber defective 	<ol style="list-style-type: none"> 1. Adjust pressure 2. Adjust alignment 3. Replace bearings 4. Repair - replace frame 5. Replace shock absorber
Problem: Tire wear rapid or uneven	
Condition	Remedy
<ol style="list-style-type: none"> 1. Wheel hub bearings worn - loose 2. Front wheel alignment incorrect 3. Tire inflation pressure incorrect 	<ol style="list-style-type: none"> 1. Replace bearings 2. Adjust alignment 3. Adjust pressure
Problem: Steering noise	
Condition	Remedy
<ol style="list-style-type: none"> 1. Cap screws - nuts loose 2. Wheel hub bearings broken - damaged 3. Lubrication inadequate 	<ol style="list-style-type: none"> 1. Tighten cap screws - nuts 2. Replace bearings 3. Lubricate appropriate components
Problem: Rear wheel oscillation	
Condition	Remedy
<ol style="list-style-type: none"> 1. Rear wheel hub bearings worn - loose 2. Tires defective - incorrect 3. Wheel rim distorted 4. Wheel lug nut(s) loose 5. Axle shaft nut loose 6. Rear suspension arm-related bushing worn 7. Rear shock absorber damaged 8. Rear suspension arm nut loose 9. Wheel studs loose - missing 	<ol style="list-style-type: none"> 1. Replace bearings 2. Replace tires 3. Replace rim 4. Tighten - replace lug nut(s) 5. Tighten nut 6. Replace bushing 7. Replace shock absorber 8. Tighten nut 9. Replace wheel studs