

BLOCK DIAGRAM

T100TA

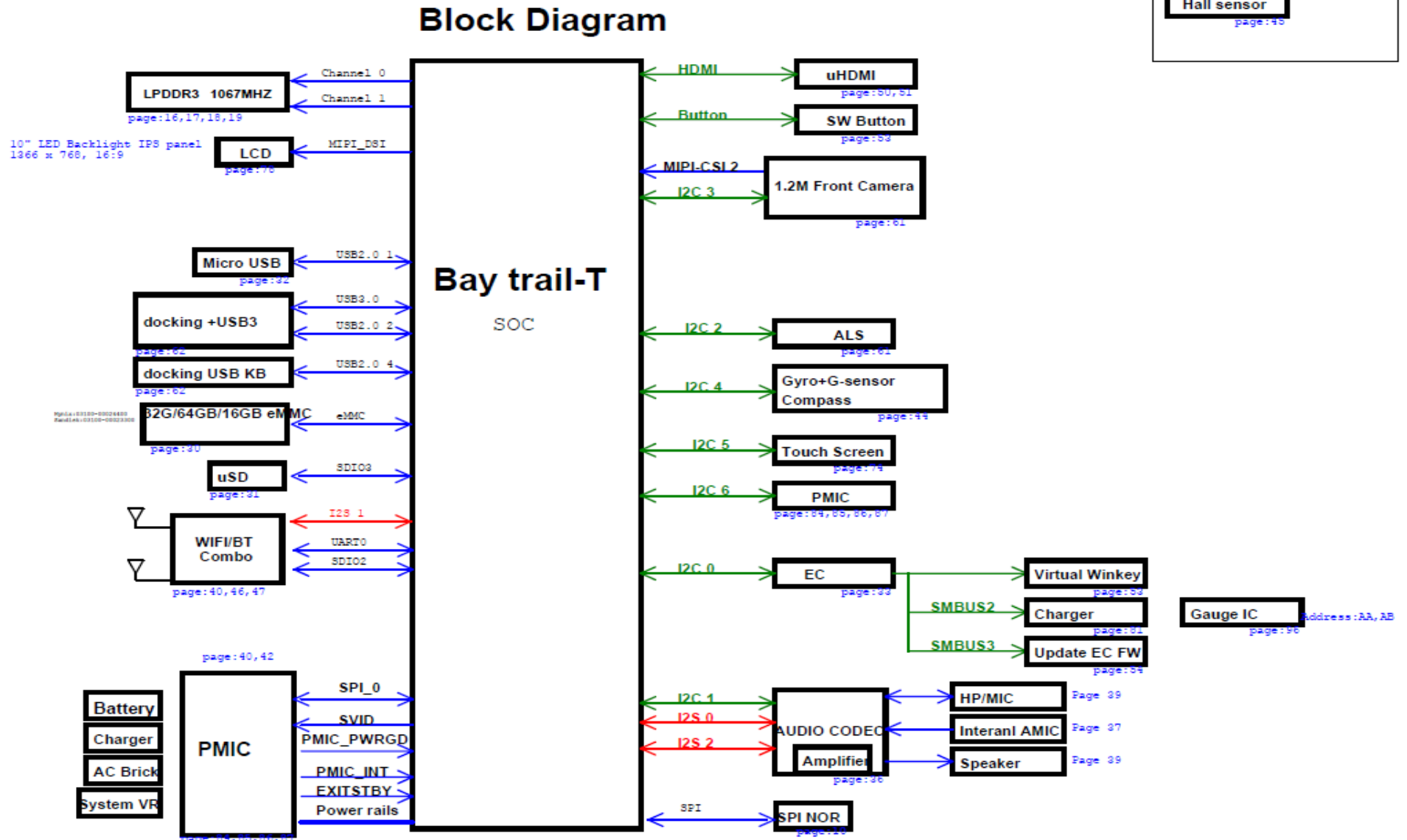

POWER FLOW

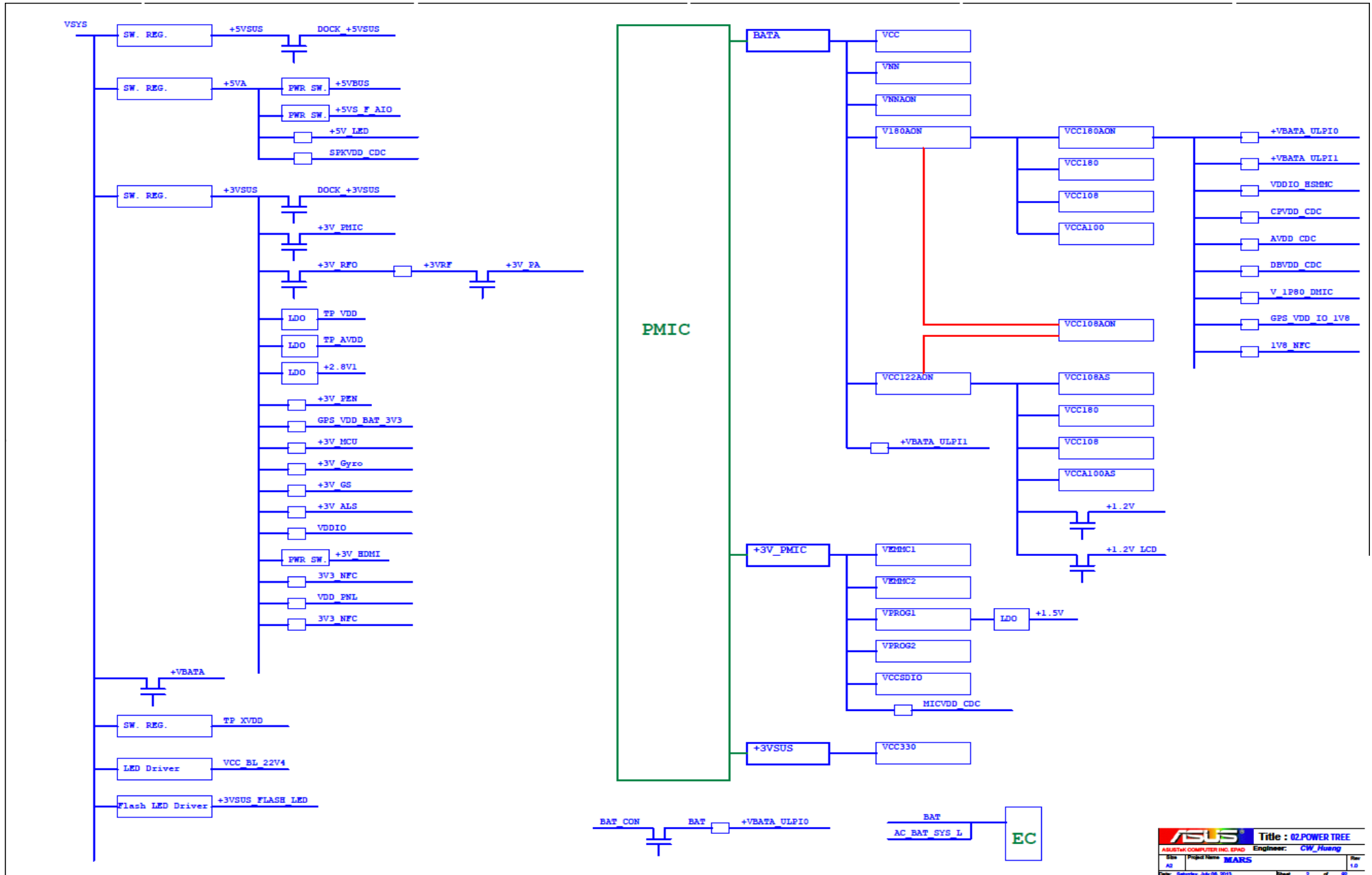

POWER ON SEQUENCE

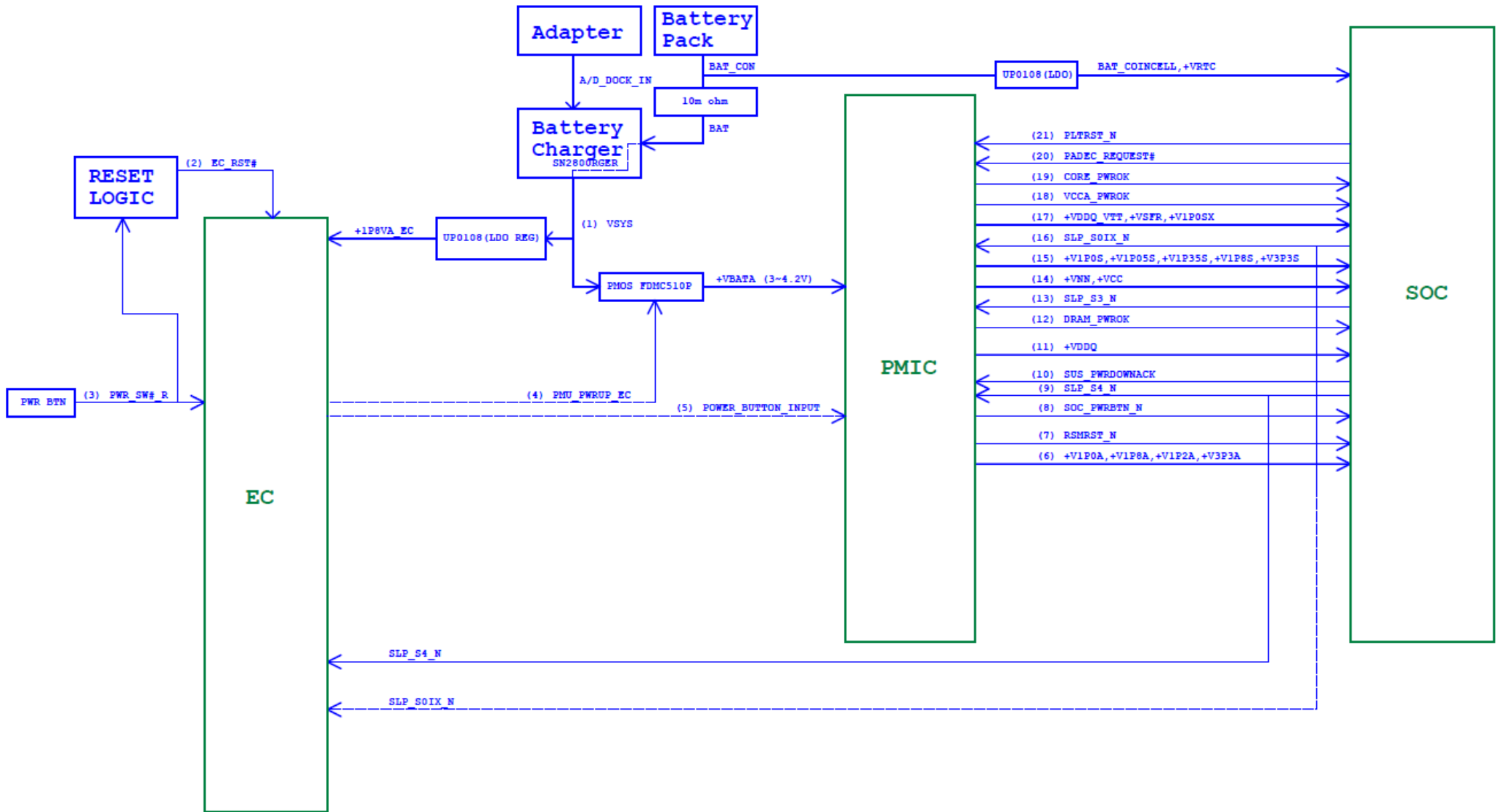

Signal Measure Point-Bottom

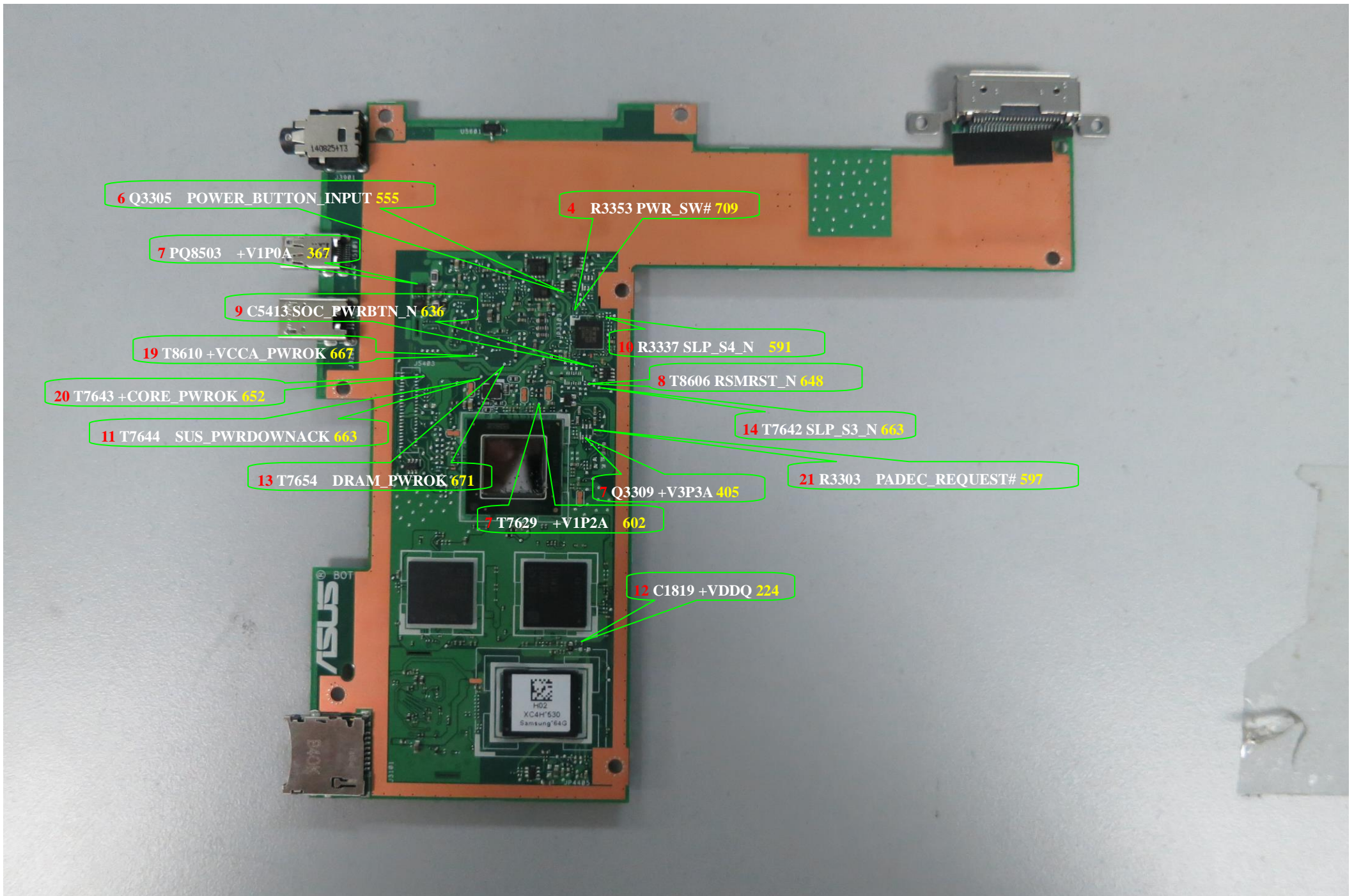

6 Q3305 POWER_BUTTON_INPUT 555

4 R3353 PWR_SW# 709

7 PQ8503 +VIP0A 367

9 C5413 SOC_PWRBTN_N 636

19 T8610 +VCCA_PWRROK 667

20 T7643 +CORE_PWRROK 652

11 T7644 SUS_PWRDOWNACK 663

13 T7654 DRAM_PWRROK 671

7 T7629 +VIP2A 602

7 Q3309 +V3P3A 405

21 R3303 PADEC_REQUEST# 597

12 C1819 +VDDQ 224

10 R3337 SLP_S4_N 591

8 T8606 RSMRST_N 648

14 T7642 SLP_S3_N 663

Signal Measure Point-Top

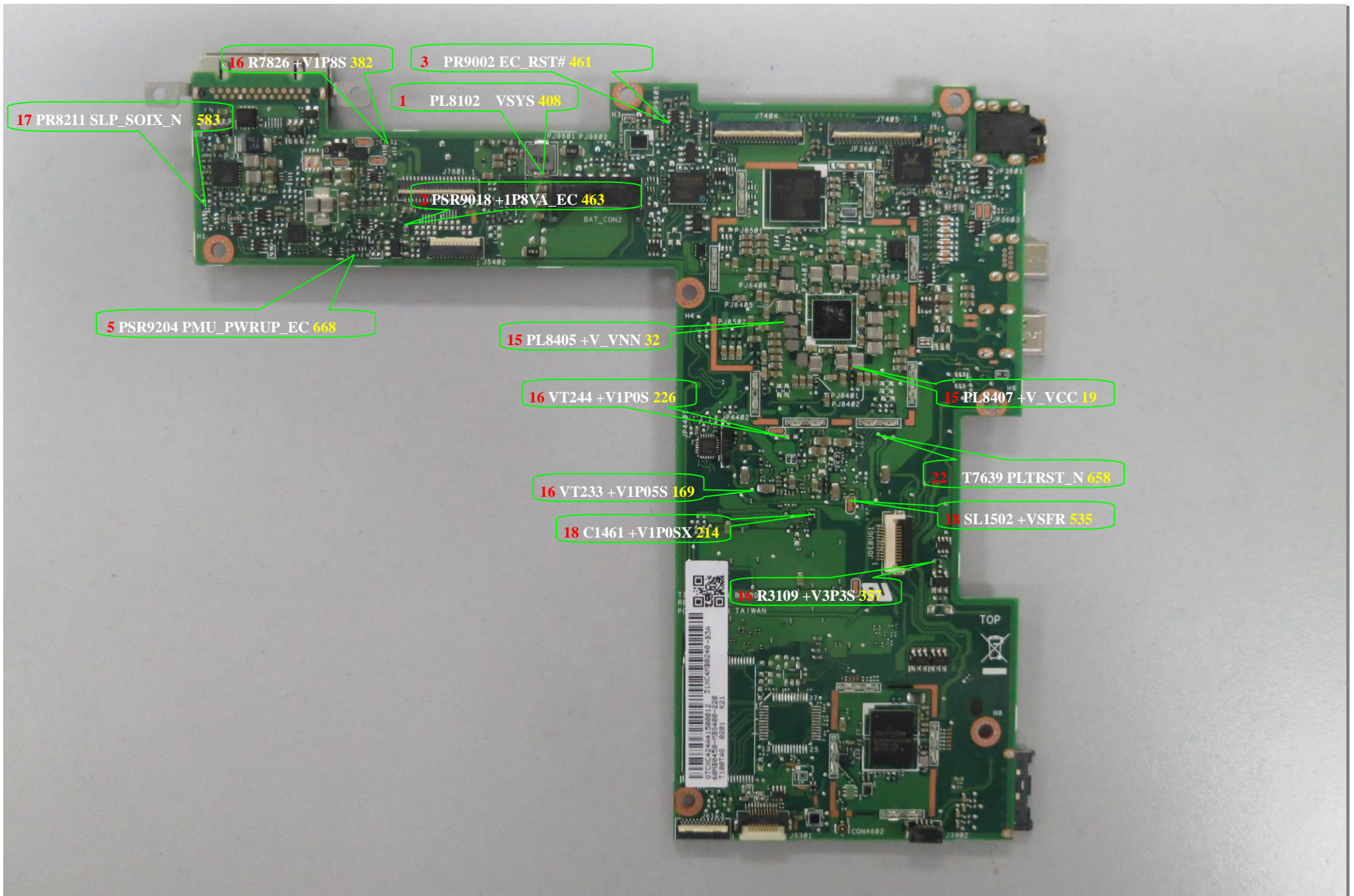

www.s-manuals.com