



## **MODELS 227A/227C**

### **DIFFERENTIAL PRESSURE INDICATOR**

*(Standard and Inverted Configurations)*

227A uses 224 DPU

227C uses 224C DPU

## **Installation Manual**

Part No. 10120, Rev. 01

July 2007

[This manual is for indicator only - see separate 224/224C DPU manual, per model number listed above.]

### **CONTENTS**

Prepages .....	Page 2
Safety Statement .....	Page 2
Product Warranty Statement.....	Page 2
Record of Changes .....	Page 2
Section 1 - Introduction .....	Page 3
1-1. General.....	Page 3
1-2. Product Description .....	Page 3
1-3. Theory of Operation .....	Page 3
1-4. Specifications .....	Page 4
Section 2 - Installation .....	Page 5
2-1. General.....	Page 5
2-2. Mounting .....	Page 5
2-3. DPU Installation .....	Page 5
2-4. Zero Check/Adjustment .....	Page 6
Section 3 - Maintenance and Calibration .....	Page 7
3-1. DPU Installation/Maintenance .....	Page 7
3-2. Tools Required for Maintenance .....	Page 7
3-3. Calibration Check .....	Page 7
3-4. Pointer Installation and Removal .....	Page 7/8
3-5. Complete Calibration .....	Page 8
3-6. Overrange Stop Adjustment.....	Page 10
3-7. Locking Drive Arm to Torque Tube .....	Page 10
3-8. Drive Arm Tightness Test .....	Page 11
Section 4 - Parts Drawing/List.....	Page 12
Figure 4-1. 227A/227C Parts Drawing.....	Page 12
Table 4-1. 227A/227C Parts List .....	Page 13
Section 5 - Install/Dimensional Drawings.....	Page 14
Figure 4-1. 227A/227C Parts Drawing .....	Page 14/15



**Before installing this instrument**, become familiar with the installation instructions in Section 2 and in the separate 224/224C DPU manual.

**DANGER** notes indicate the presence of a hazard which **will** cause **severe** personal injury, death, or substantial property damage if warning is ignored.

**WARNING** notes indicate the presence of a hazard which **can** cause **severe** personal injury, death, or substantial property damage if warning is ignored.

**CAUTION** notes indicate the presence of a hazard which **will** or **can** cause **moderate** personal injury or property damage if warning is ignored.

**DANGER, WARNING, and/or CAUTION** notes that appear on the following pages of this manual should be reviewed before proceeding: **None. (Important! Before installing or operating this instrument, review all safety notices contained in the separate 224/224C DPU manual, per models listed**

### **PRODUCT WARRANTY STATEMENT**

The product warranty applicable to this instrument is stated on the back cover of this manual.

### **DPU "C" VERSION DESIGN CHANGE**

The 227C utilizes a 224C DPU, which is a redesigned version of the 224 DPU. The "C" version is identical in function, performance, installation, and operation to the previous version - redesign was for improved manufacturing only. This design change does not affect the instrument being actuated. **Selected configurations of 227A (using a 224 [Non-C] DPU) are for Nuclear/Government only.**

### **RECORD OF CHANGES**

	<b>DATE</b>	<b>DESCRIPTION</b>
00E2	5/00	Reduced Booklet 227C INV. w/224C APX (99H4)
00K25c	11/00	Booklet Format 227C w/224 DPU information in body
03D77d	4/03	Combined 200/227A/227C Manual
03G76d	7/03	Combined 227A/227C (Standard and Inverted) Versions (Replaces 227A (10121), 227C (10130) Inverted, and 227 portion of 200/227A/227C (10055) Manuals); Rev. Co. Name/Logo to PRIME Measurement Products; Added para. 2-4, Zero Check/Adjustment procedure; Rev. Section 3 - Maintenance and Calibration; Rev. Section 4 - Parts Drawing and Parts List Rev. Section 5 - Install/Dimensional Drawings
04L55a	12/04	Rev. warranty - made specific to M227A/227C units
01	7/07	Revised corporate name/logo/contact information to reflect Cameron ownership.

## **SECTION 1 - INTRODUCTION**

### **1-1. General**

The Model 227A/227C Differential Pressure Indicator is designed to measure liquid flow or liquid level. In flow measurement applications, the instrument is connected to the low and high pressure sides of a primary device (orifice plate, a venturi tube, or a flow tube) located in the process run. In liquid level measurement applications, the instrument is connected to monitor changes in differential pressure relative to variations of liquid height in a vessel.

### **1-2. Product Description**

The indicator has a 6 inch dial. The indicating pointer traverses a 270° arc (nominal) to measure differential pressure, flow, or liquid level. The indicator movement has a micrometer screw for range adjustment. Zero is adjusted by "slipping" pointer on hub, which can be done without removing the scaleplate or pointer. The Range can also be adjusted without removing the scaleplate or pointer. Linearity adjustments are accessible after removal of the scale plate.

The 227A is actuated by a Model 224 Differential Pressure Unit (DPU). The 227C is actuated by a Model 224C DPU. Refer to the separate DPU Manuals.

### **1-3. Theory of Operation**

The 227A/227C consists of the actuating DPU and the indicator (case assembly).

#### **A. Differential Pressure Unit (DPU)**

The 224/224C DPU consists of a dual bellows assembly (one high pressure and one low pressure bellows), which is enclosed by a set of two pressure housings (pressure heads).

The dual bellows assembly consists of two internally-connected bellows, a center plate, overrange valves, a temperature compensator, a torque tube assembly, and range springs. The bellows and center plate are completely filled with a non-corrosive liquid and then sealed. The pressure housings, located on either side of the center plate, are connected by pipe or tubing to the system primary device. Variations in differential pressure within the pressure housing cause the bellows to expand/contract laterally, in the direction of lower pressure. The lateral movement of the bellows is converted to angular rotation as transmitted to the torque tube shaft by the drive arm. The torque tube assembly provides mechanical output in response to the bellows movement and actuates the mechanism of the process monitoring instruments. For more information on the DPU, refer to the separate 224/224C DPU manual.

#### **B. Indicator**

The indicator is attached directly to the actuating unit (DPU). The indicator consists of a drive arm assembly, linkage, and a movement assembly to which the indicating pointer is attached. Changes in differential pressure are sensed by the DPU bellows and transmitted as rotary motion through the torque tube to the drive arm assembly of the indicator. The linkage and movement assembly respond to the action of the drive arm assembly to position the pointer in direct relationship to the amount of bellows travel.

## 1-4. Specifications

### Accuracy (DP Range):

0-30" w.c. to 0-50" w.c. (0-75 mbar to 0-124 mbar).....	±0.75% of full scale
0-51" w.c. to 0-60 psi (0-127 mbar to 0-4.1 bar).....	±0.5% of full scale
0-61 psi to 0-150 psi (0-4.2 bar to 0-10.3 bar).....	±0.75% of full scale
0-151 psi to 0-400 psi (0-10.4 bar to 0-27.6 bar).....	±1.0% of full scale
0-401 psi to 0-600 psi (0-27.7 bar to 0-41.3 bar).....	±1.5% of full scale
0-601 psi to 0-1,000 psi (0-41.4 bar to 0-69 bar).....	±4.0% of full scale

Dial Size .....	6" Diameter
Temperature Limits .....	-40 °F/°C to +180°F (+82°C) (+40°F minimum for water filled units)
Indicator Case .....	Aluminum Alloy, Enamel or Epoxy Finish or 316 SST
Lens.....	Polycarbonate (shatterproof glass for SST Version)
O-rings (Wetted) .....	Buna-N, Viton, or EPT
Overall Dimensions.....	per configuration and 224/224C DPU housing rating. See ODD drawings in Section 5.
Weight .....	6 to 9.5 lbs (approx.) Weight depends on DPU configuration/materials.

### Differential Pressure Unit (DPU):

For DPU specifications, refer to the separate 224/224C DPU manual.

## **SECTION 2 - INSTALLATION**

### **2-1. General**

The instrument should be inspected at time of unpacking to detect any damage that may have occurred during shipment. **Note:** *The DPU was checked for accuracy at the factory — do not change any of the settings during examination or accuracy will be affected.*

*For applications requiring special cleaning/precautions, a polyethylene bag is used to protect the instrument from contamination. This bag should be removed only under conditions of extreme cleanliness.*

### **2-2. Mounting**

Per ODD drawings in Section 5.

### **2-3. DPU Installation**

Refer to the separate 224/224C DPU manual, per models listed on front page, for DPU installation and maintenance.

## 2-4. Zero Check/Adjustment

It may be necessary to reset the ZERO before placing the 227A/227C into service. This procedure can be accomplished without removing the scaleplate.

### NOTICE

Adjusting the instrument's ZERO in accordance with the following procedure does not invalidate the original factory calibration or warranty.

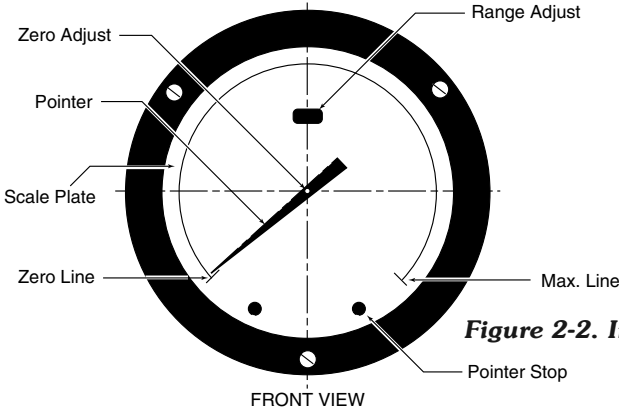

Figure 2-2. Instrument Face

1. Fix the instrument in a stable position, with the top of the DPU level with the horizontal plane.
2. Using a flat-blade screwdriver, remove the three (3) or (9 on SST case) bezel screws (see Figure 2-2).
3. Lift the screws, bezel, lens, and lens gasket away from the case.
4. Set the pointer to ZERO position, by "slipping" the pointer on the hub, per the following (refer to Figure 2-3):

With a 1/4" open-end wrench (included in calibration kit 0288-1032B), hold the hexagon pointer hub fixed and rotate the pointer with fingers until the pointer accurately indicates ZERO on the scale.

5. Reassemble the unit, attaching the lens gasket, lens, and bezel to the case. Secure the bezel with the three (3) or 9 on SST case) bezel screws. Tighten the screws until they are snug.

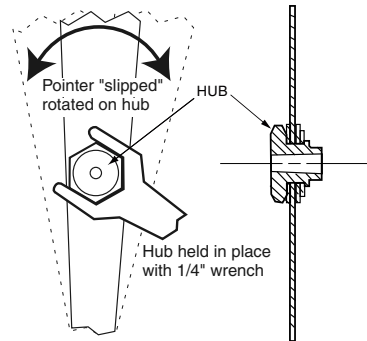

Figure 2-3. "Slipping" Pointer

## SECTION 3 - MAINTENANCE AND CALIBRATION

### 3-1. DPU Installation/Maintenance/Repair

DPU inspection, cleaning, service, repair, range change, and BUA replacement procedures (along with applicable **WARNINGS**, **CAUTIONS**, and **NOTICES**, are presented in the separate **224/224C DPU** manual.

### 3-2. Tools Required For Maintenance

**Table 3-1. Tools**

<b>Equipment</b>	<b>Purpose</b>
Pointer Puller	Pointer Removal
Small Screwdriver	Scaleplate Removal and Replacement
Medium Screwdriver	Bezel Removal and Replacement
1/4" & 1/8" Open-end Wrenches	Zero (1/4") /Range (1/8") Adjustment
For DPU specific tools, refer to separate DPU Manual.	

### 3-3. Calibration Check

To ensure the unit calibration is within factory-set calibration tolerances, perform the following procedure. **NOTICE: Review all procedures, WARNINGS/NOTICES** in the separate **224/224C DPU** manual **BEFORE** performing this procedure.

1. Mount instrument and connect to a standard pressure source (see separate 224/224C manual).
2. If the zero indication is incorrect, remove bezel/lens assembly and re-adjust zero, per Zero Check/Adjustment procedure, per paragraph 2-4.
3. Apply 0, 50, and 100% of full scale pressure. If indication is within specified limits, no adjustments are necessary. If indication is not within specified limits, perform a complete calibration, per paragraph 3-5.

### 3-4. Pointer Installation and Removal

During adjustment and calibration of the unit, it may be necessary to remove and reinstall the pointer, per the following procedures:

#### A. Pointer Installation

1. Position pointer on movement shaft with pointer set at zero scale. It may be necessary to enlarge the hub hole, using a tapered broach (included in the toolkit (p/n 0288-1032B).
2. Lightly tap pointer hub with a hand-set or other flat-end tool. Use perpendicular blows to avoid bending shaft.
3. Check indicating switch for calibration over its entire range (refer to Switch Calibration in this section). If indicating switch is correctly calibrated, secure pointer to movement shaft by tapping hub with a hand-set or other flat-end tool.

*(Continued on next page...)*

### 3-4. Pointer Installation and Removal (Continued)

#### B. Pointer Removal

Pointer is removed with Pointer Puller (p/n 0163-0005B), which is included in the toolkit (p/n 0288-1032B), see Figure 3-1.

1. Slide pointer puller along pointer until pin protruding from tip of screw in pointer puller is directly over movement shaft and arms of pointer puller are directly under pointer.

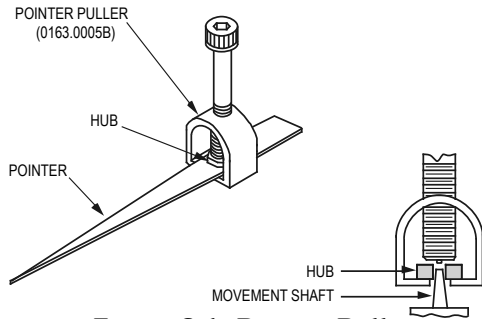

**Figure 3-1. Pointer Puller**

2. Gently turn knurled head of screw clockwise, pushing pin against movement shaft and lifting pointer with arms. Finger pressure should be sufficient to pull the pointer free. If more pressure is required, an Allen wrench (inserted into head of the screw) can be used. However, care should be exercised: too much pressure can cause the pin to break.

### 3-5. Complete Calibration (DP=Differential Pressure)

A complete calibration of instrument is required whenever the DPU assembly is replaced. **NOTICE: Review all procedures, WARNINGS/NOTICES** in the separate **224/224C DPU** manual **BEFORE** performing this procedure.

1. Securely mount instrument in an approximately level position and connect DPU into the test setup, as described in the appropriate (separate) DPU manual.
2. Attach linkage between drive arm and movement. See Figure 3-2 (standard 227A/C) or Figure 3-3 (Inverted 227A/C) for linkage alignment at 50% DP. Inspect parts for straightness and pivot-fit without binding.

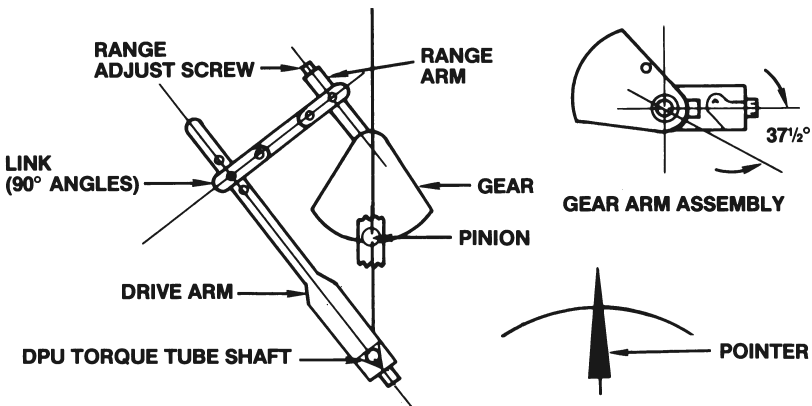

**Figure 3-2. (Standard) Range/Linearity Adj. (50% DP)**



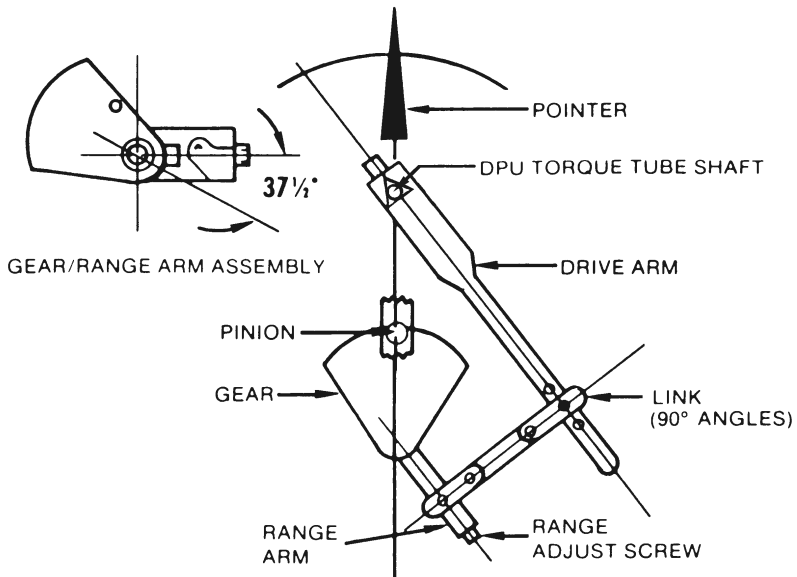

**Figure 3-3. (Inverted) Range/Linearity Adj. (50% DP)**

**Pressure)**

3. Set pointer at zero on scale by slipping pointer on hub. Hold tip of pointer and turn hub with wrench (refer to paragraph 2-4).
4. Apply 100% DP. If pointer exceeds 100% on scale, lengthen range arm. Remove pressure.
5. Set zero and span, using hub for zero adjustment and range adjust screw on the movement for span adjustments.
6. Apply 50% DP. If pointer does not indicate 50% scale, a linearity adjustment is necessary. Loosen drive arm screw and move arm to shift pointer in direction of error (approx. 10:1). Tighten drive arm screw.
7. Release pressure and reset pointer at zero. Check the span. If gear in movement reaches limit of travel as a result of linearity adjustment (step 6), slip range arm along gear approximately 5 degrees from normal 37.5 degree angle to approximately 43 degrees. Range arm is slipped by applying pressure to range arm with thumb, while holding gear firmly in place. Retest pointer response at 50% and 100% DP, and adjust linkage until readings are acceptable.
8. Apply 0%, 25%, 50%, 75%, 100%, 75%, 50%, 25%, and 0% of DP consecutively to instrument without overshoot. Lightly tap indicator to overcome friction. Pointer should accurately indicate each applied pressure.
10. Test instrument repeatability by applying 0%, 50%, 0%, 50% DP. Indicator should accurately indicate each applied pressure.

(Continued on next page...)

### 3-5. Complete Calibration (Continued) (DP=Differential Pressure)

11. Set overrange stops to prevent pointer from striking snubbers on scale (see paragraph 3-6). Tighten all screws. Test setting by manually moving pointer from zero position to 50%, then let the pointer return freely. An off-set in zero reading indicates pointer slippage. If necessary, tap pointer hub to tighten it to shaft.
12. Reassemble unit, making sure bezel screws are snug.

### 3-6. Overage Stop Adjustment

1. Apply sufficient pressure to the high pressure housing to deflect the pointer against the snubber on the scale plate. Slide the upper overrange stop against the drive arm and tighten the overrange stop screw.
2. Apply sufficient pressure to the low pressure housing to deflect the pointer against the zero stop snubber on the scale plate. Slide the zero-stop against the drive arm and tighten the zero-stop screw.
3. Remove the pointer and calibration scale. Replace the pointer at zero (adjust zero as necessary). Replace the lens and bezel assembly.

### 3-7. Locking Drive Arm to Torque Tube

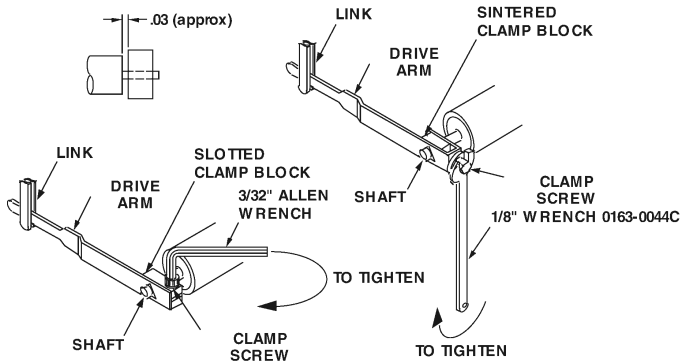

Figure 3-4. Locking Drive Arm to Torque Tube

1. Slip the drive arm over the torque tube shaft; clear the end of the torque-tube housing by approximately 0.030-inches before securing to prevent interference.
2. To tighten the drive arm assembly onto the torque-tube shaft:
  - a. While supporting the block and shaft, tighten the clamp screw until snug to the shaft.
  - b. Still supporting block/shaft, tighten clamp screw an additional:
    - Sintered: 1/3 to 1/2 turn (This screw can normally turn one full revolution before breaking.)
    - Slotted: 1/4 to 1/3 turn (The slot in the slotted clamp block should still be open.)

**NOTICE: For Seismic and High Shock Qualified Units, perform Drive Arm Tightness Test, per paragraph 3-8.**

### **3-8. Drive Arm Tightness Test**

This procedure tests the drive arm to torque tube attachment for tightness, by applying torque developed by the DPU onto a fixed drive arm. Care should be taken to apply pressure slowly, as torque is being applied to the connection through the torque tube drive shaft and not the torque tube itself.

With pointer at normal 0% torque tube rotation position (max. minimum scale position or 0% on a normal 0 to 100% scale unit), adjust drive arm stop bracket (or use alternate means) to prevent pointer from moving (stop bracket interferes with drive arm movement). Note: On reverse acting/split range units, it will be necessary to pressurize DPU to move pointer to max. minimum scale position, and on suppressed units, it will be necessary to apply pressure to establish a reference point to check for "zero" shift.

Pressurize DPU to full calibrated scale DP (100% of full scale range) to achieve 8-degrees of torque tube drive shaft equivalent torque onto the connection.

Observe shift in the unit "zero" following DPU depressurization (as required) and drive arm stop bracket readjusting (to allow free movement of drive arm and pointer). A downscale (counter-clockwise) shift in "zero" of greater than 1/2% is indicative of drive arm slippage necessitating further clamp block tightening.

**SECTION 4 - PARTS DRAWING/LIST**

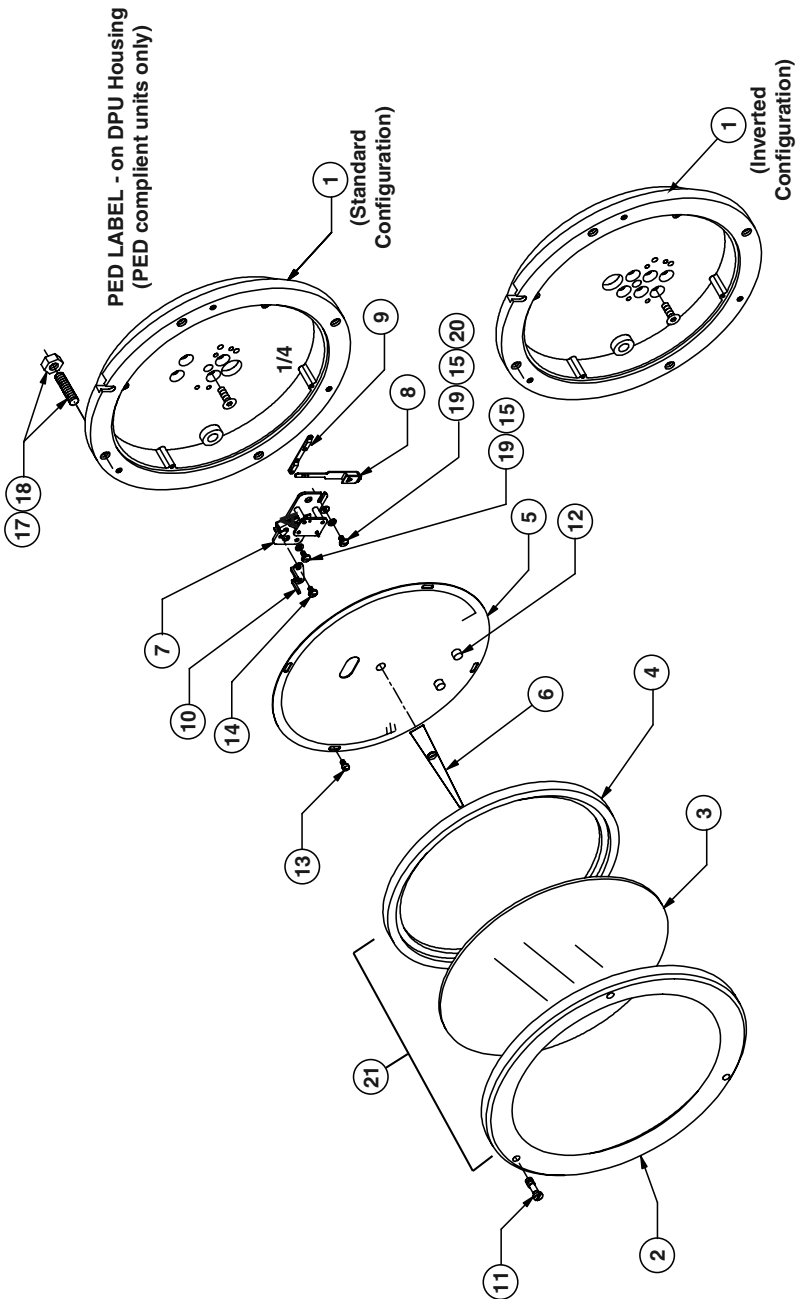

**Figure 4-1. 227A/227C Parts Drawing**

**Table 4-1. 227A/227C Parts List**

<b>Item</b>	<b>Description</b>	<b>Part No.</b>	<b>Per Unit</b>
<b>1</b>	Case:		1
	Standard	0227-0014C	
	Inverted	0227-1028C	
<b>2</b>	Bezel (Part Of Item #21)	0277-0029C	1
<b>3*</b>	Lens, Cover (Part Of Item #21)	0181-0038C	1
<b>4*</b>	Gasket (Part Of Item #21)	0277-0026C	1
<b>5**</b>	Scale Plate		1
	White On Black Background	0227-0013C	
	Black On White Background	0227-1003C	
<b>6*</b>	Pointer Assembly:		1
	White	0288-0030B	
	Black	0288-0031B	
<b>7</b>	Movement Assembly	0288-0035B	1
<b>8</b>	Drive Arm Assembly	0226-0023B	1
<b>9</b>	Link Assembly	0226-0020B	1
<b>10</b>	Stop Bracket	0288-0028C	1
<b>11*</b>	Bezel Screws, SST	0181-0007C	3
<b>12</b>	Snubber	0226-0028C	2
<b>13</b>	Screw, Sl Fil. Hd. 4-40 X 3/16, SST	0114-0023J	4
<b>14*</b>	Screw, Bd. Hd., 4-40 X 3/16, SST	0117-0012J	1
<b>15*</b>	Washer, Split Lock, #4, SST	0003-0062K	2
<b>16</b>	Screw, Flat Hd., #10 X 1/2	0240-0019J	6
<b>17</b>	Screw, Slotted Set, 1/4-20 X 1	0340-0003J	4
<b>18</b>	Nut, 1/4-20, Hex, STL	0500-0010J	4
<b>19</b>	Screw, Rd. Hd., 4-40 X 1/4, SST	0111-0034J	2
<b>20</b>	Washer, Flat, #4, SST	0003-0096K	1
<b>21</b>	Bezel Assembly (Items 2, 3, & 4)	0277-0018B	1
<b>22</b>	Differential Pressure Unit (DPU) (Not Shown) 227A Uses 224 DPU 227C Uses 224C DPU Inverted Units Use Inverted 224/224C DPUs	SEE DPU MANUAL	1
<b>23</b>	Calibration Kit (Not Shown)	0288-1032B	1
<b>24</b>	Plug, Restrictor Vent (Not Shown)	0080-1022T	1
<p><b>Notes:</b> * Indicates recommended spare part; ** SCALE PLATE IDENTIFICATION:                      If the scale plate shows an SCR number, this will identify it. Otherwise, provide the following information:                      1. Square Root or Linear Graduations                      2. Scale (e.g., 0-100, 25-0-100, etc.)                      3. Number of Graduations (linear scales only)                      4. Data (e.g., PSI (bar), inches of water column (meter), etc.)                      5. Standard plates have black background                      When ordering parts, specify serial number of instrument. Minimum parts order is \$100.00. For 224/224C parts, refer to separate 224/224C DPU manual.</p>			

## SECTION 5 - INSTALL/DIMENSIONAL DRAWINGS

**Note:** For other DPU dimensional information, refer to the separate DPU manual (as listed on the front page).

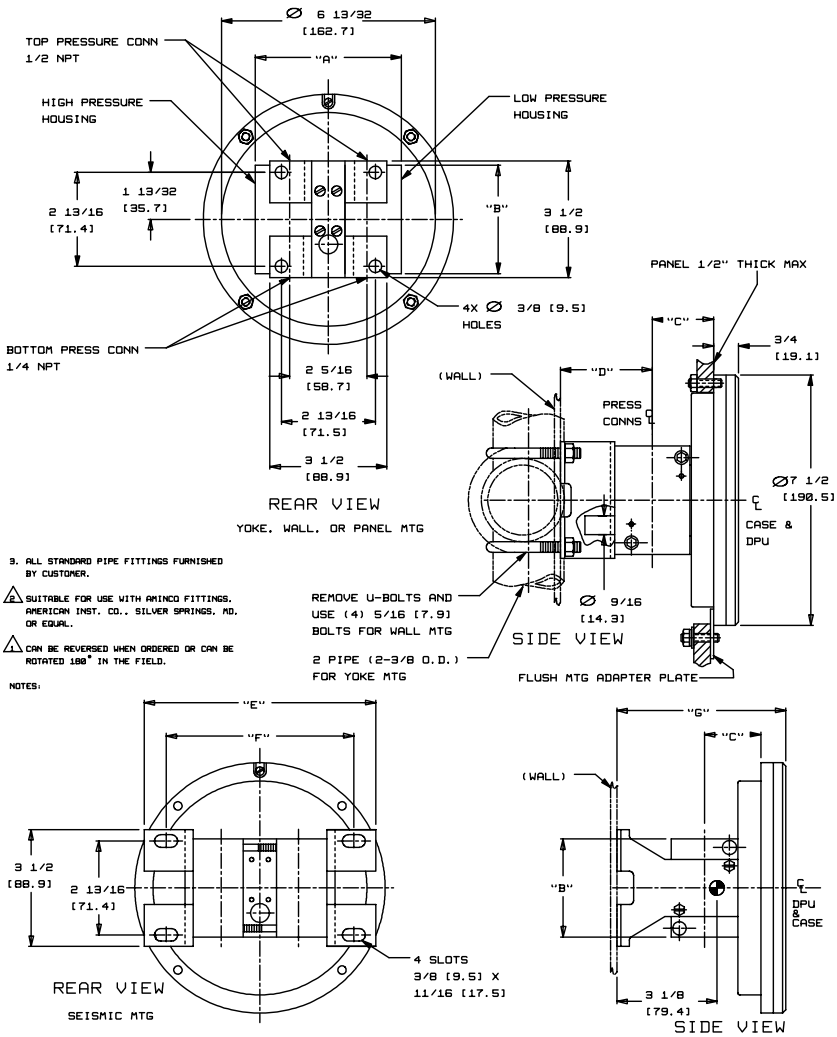

PRESSURE RATING	MATERIAL	DIM A ±.03	DIM B ±.01	DIM C	DIM D	DIM E	DIM F	DIM G	PRESS CONNECTION	
									TOP	BOTTOM
500 TO 1500 PSI	ALL	4 (101.6)	2-15/16 (74.6)	1-43/64 (42.5)	2-5/8 (66.7)	6-15/16 (176.2)	6-5/8 (142.9)	5-3/16 (131.7)	1/2 NPT	1/4 NPT
									⚠	⚠
									9/16-18 UNF	9/16-18 UNF
										1/4 NPT
3000 TO 10,000 PSI	ALL	4-3/8 (111.1)	3-1/4 (82.6)	1-51/64 (45.6)	2-3/4 (69.9)	7-5/16 (187.9)	8 (152.4)	5-19/64 (134.5)	1/2 NPT	1/2 NPT
									7/16 NS	7/16 NS
									1/8 NPT	1/8 NPT

**Figure 5-1. 227A/227C Dimensions** (Based on 0227C-10013, Rev.00)

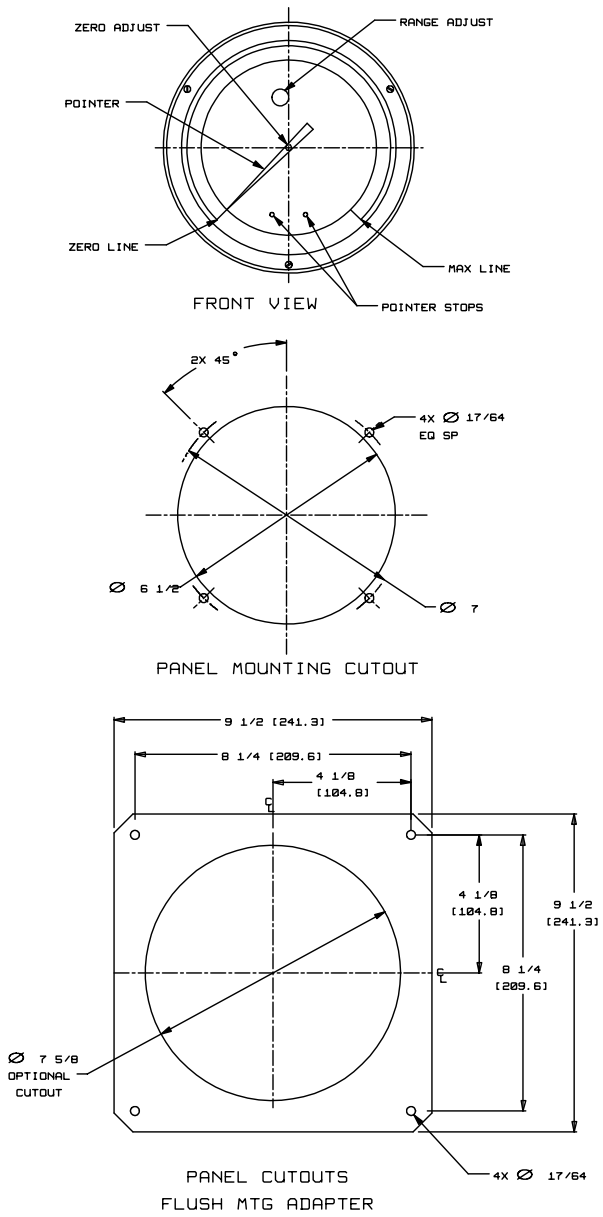

**Figure 5-1. 227A/227C Dimensions** (Continued)

## Product Warranty

### A. Warranty

Cameron International Corporation ("Cameron") warrants that at the time of shipment, the products manufactured by Cameron and sold hereunder will be free from defects in material and workmanship, and will conform to the specifications furnished by or approved by Cameron.

### B. Warranty Adjustment

- (1) If any defect within this warranty appears, Buyer shall notify Cameron immediately.
- (2) Cameron agrees to repair or furnish a replacement for, but not install, any product which within one (1) year from the date of shipment by Cameron shall, upon test and examination by Cameron, prove defective within the above warranty.
- (3) No product will be accepted for return or replacement without the written authorization of Cameron. Upon such authorization, and in accordance with instructions by Cameron, the product will be returned shipping charges prepaid by Buyer. Replacements made under this warranty will be shipped prepaid.

### C. Exclusions from Warranty

- (1) THE FOREGOING WARRANTY IS IN LIEU OF AND EXCLUDES ALL OTHER EXPRESSED OR IMPLIED WARRANTIES OF MERCHANTABILITY, OR FITNESS FOR A PARTICULAR PURPOSE, OR OTHERWISE.
- (2) Components manufactured by any supplier other than Cameron shall bear only the warranty made by the manufacturer of that product, and Cameron assumes no responsibility for the performance or reliability of the unit as a whole.
- (3) "In no event shall Cameron be liable for indirect, incidental, or consequential damages nor shall the liability of Cameron arising in connection with any products sold hereunder (whether such liability arises from a claim based on contract, warranty, tort, or otherwise) exceed the actual amount paid by Buyer to Cameron for the products delivered hereunder."
- (4) The warranty does not extend to any product manufactured by Cameron which has been subjected to misuse, neglect, accident, improper installation or to use in violation of instructions furnished by Cameron.
- (5) The warranty does not extend to or apply to any unit which has been repaired or altered at any place other than at Cameron's factory or service locations by persons not expressly approved by Cameron.

## Product Brand

Barton® is a registered trademark of Cameron International Corporation ("Cameron").

### MEASUREMENT SYSTEMS

Formerly: NuFlo Measurement Systems • Barton Instrument Systems • Caldon, Inc.

HOUSTON  
HEAD OFFICE | **281.582.9500**

NORTH  
AMERICA | **1.800.654.3760**  
ms-us@c-a-m.com

ASIA  
PACIFIC | **603.2287.1039**  
ms-asiapacific@c-a-m.com

EUROPE,  
MIDDLE EAST  
& AFRICA | **44.1243.826741**  
ms-uk@c-a-m.com

USA • CANADA • UK • SCOTLAND • CHINA • UAE  
ALGERIA • MALAYSIA • SINGAPORE • [WWW.C-A-M.COM/FLO](http://www.c-a-m.com/flo)

