

Small Signal Diode

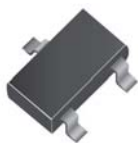

Features

- ✧ Fast switching speed
- ✧ Surface device type mounting
- ✧ Moisture sensitivity level 1
- ✧ Matte Tin(Sn) lead finish with Nickel(Ni) underplate
- ✧ Pb free version and RoHS compliant
- ✧ Green compound (Halogen free) with suffix "G" on packing code and prefix "G" on date code

Mechanical Data

- ✧ Case :SOT-23 small outline plastic package
- ✧ Terminal: Matte tin plated, lead free., solderable per MIL-STD-202, Method 208 guaranteed
- ✧ High temperature soldering guaranteed: 260°C/10s
- ✧ Weight : 0.008gram (approximately)
- ✧ Marking Code : KL1, KL2, KL3, KL4

Pin Configuration

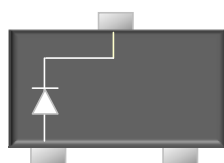

BAT54

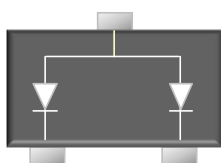

BAT54A

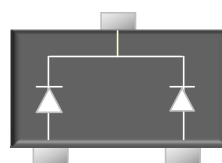

BAT54C

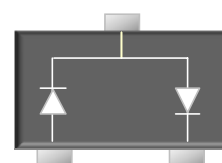

BAT54S

Ordering Information

Package	Part No.	Packing	Marking
SOT-23	BAT54 RF	3K / 7" Reel	KL1
SOT-23	BAT54A RF	3K / 7" Reel	KL2
SOT-23	BAT54C RF	3K / 7" Reel	KL3
SOT-23	BAT54S RF	3K / 7" Reel	KL4
SOT-23	BAT54 RFG	3K / 7" Reel	KL1
SOT-23	BAT54A RFG	3K / 7" Reel	KL2
SOT-23	BAT54C RFG	3K / 7" Reel	KL3
SOT-23	BAT54S RFG	3K / 7" Reel	KL4

Suggested PAD Layout

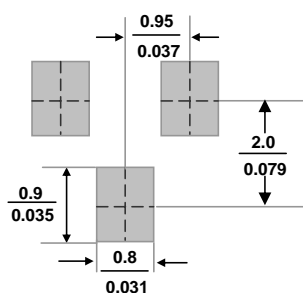

Maximum Ratings and Electrical Characteristics

Rating at 25°C ambient temperature unless otherwise specified.

Maximum Ratings

Type Number	Symbol	Value	Units
Peak Repetitive Peak reverse voltage	V_{RRM}	30	V
Working Peak Reverse Voltage	V_{RWM}		
DC Reverse Voltage	V_R		
Forward Continuous Current	I_F	200	mA
Repetitive Peak Forward Current($t_p \leq 1s; \delta \leq 0.5$)	I_{FRM}	300	mA
Forward surge current @ $t < 1.0s$	I_{FSM}	600	mA
Power Dissipation	P_d	230	mW
Thermal resistance, junction to ambient air	$R_{\theta JA}$	500	°C/W
Operating and Storage temperature	T_j, T_{STG}	-55 to 150	°C

Small Signal Diode

Electrical Characteristics

Type Number		Symbol	Min	Max	Units
Reverse Breakdown Voltage	$I_R = 100\mu A$	$V_{(BR)}$	30	--	V
Forward Voltage	$I_F = 0.1mA$	V_F	--	0.24	V
	$I_F = 1mA$		--	0.32	V
	$I_F = 10mA$		--	0.40	V
	$I_F = 30mA$		--	0.50	V
	$I_F = 100mA$		--	0.80	V
Reverse current	$V_R = 25V$	I_R	--	2.0	μA
Total Capacitance	$V_R = 1V, f = 1.0MHz$	C_T	--	10	pF
Reverse Recovery Time	$I_F = I_R = 10mA, R_L = 100\Omega, I_{RR} = 1mA$	t_{rr}	--	5.0	nS

Tape & Reel specification

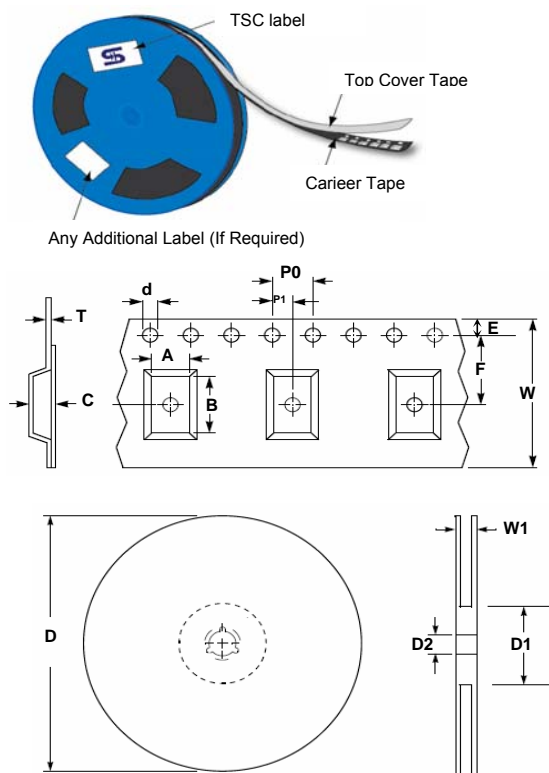

Item	Symbol	Dimension(mm)
Carrier width	A	3.15 ± 0.10
Carrier length	B	2.77 ± 0.10
Carrier depth	C	1.22 ± 0.10
Sprocket hole	d	1.50 ± 0.10
Reel outside diameter	D	178 ± 1
Reel inner diameter	D1	55 Min
Feed hole width	D2	13.0 ± 0.20
Sprocke hole position	E	1.75 ± 0.10
Punch hole position	F	3.50 ± 0.05
Sprocke hole pitch	P0	4.00 ± 0.10
Embossment center	P1	2.00 ± 0.05
Overall tape thickness	T	0.229 ± 0.013
Tape width	W	8.10 ± 0.20
Reel width	W1	12.30 ± 0.20

Small Signal Diode

Rating and Characteristic Curves

FIG 1 Typical Forward Characteristics

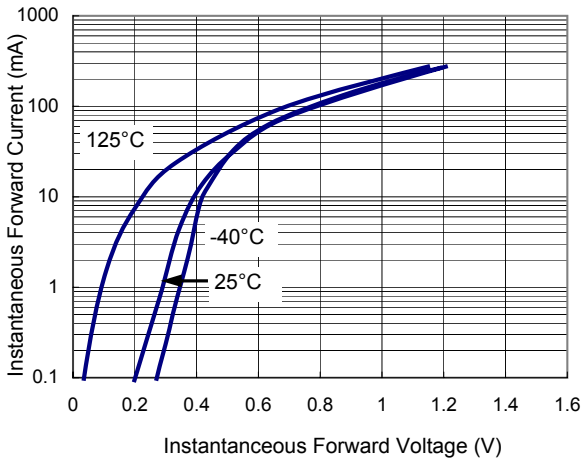

FIG 2 Typical Reverse Characteristics

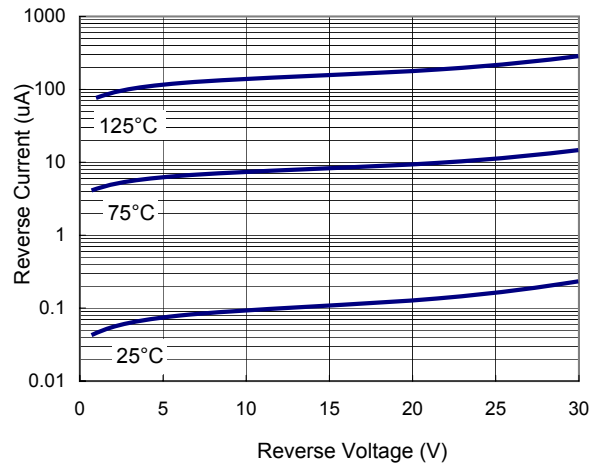

FIG 3 Admissible Power Dissipation Curve

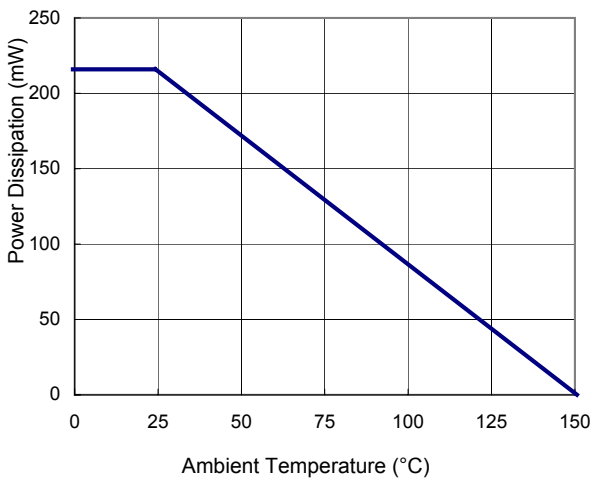
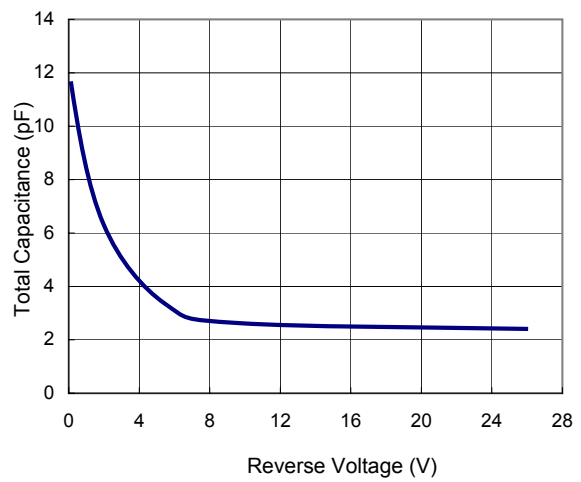

FIG 4 Typical Junction Capacitance



www.s-manuals.com