



## Contents

3	Introduction
5	Functional characteristics
7	Operating description of the delayed blow-back Locking System
10	How the double action works
14	Instructions for using the Benelli B 76 pistol
15	Safety
17	Extracting the magazine
19	Filling (loading) the magazine
23	Loading the pistol
29	Firing
30	Pistol disassembly
38	Cleaning the pistol
40	Assembling the pistol
45	Automatic pistol components

## Introduction

The world wide success of its Automatic Hunting Shotgun inspired Benelli Armi S.p.A. to do further research in the field of automatic weapons and in particular handguns to once again offer its select clientele a pistol of exceptional performance. Years of careful study and patient research in ballistics as well as experience at the technical level in mechanical construction, have made possible the creation of a weapon of revolutionary design. Qualities of instant firing readiness, absolute safety, and exceptional recoil control and accuracy have been achieved. The end result is a weapon that combines the quality and performance of a match target pistol with the rugged dependability of a military, police and personal defense arm.

## Functional Characteristics

— The weapon, one of the few in the 9 Para caliber range built today with a special breech locking mechanism allowing the use of a rigidly fixed barrel making it unique for its kind.

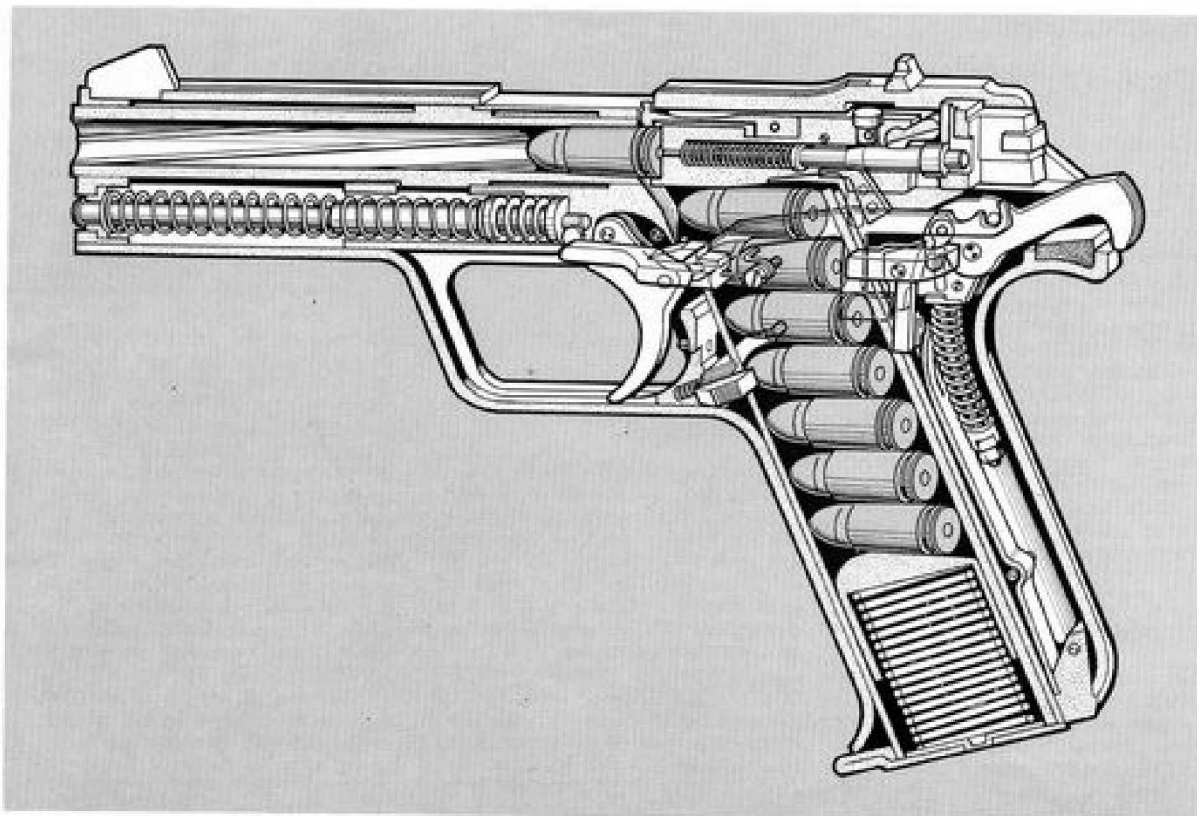
— The special double action system is carefully designed to be made with a minimum of robust parts, allowing a light double action pull with a short trigger travel.

— The pistol grip frame is made of stamped alloy steel plate with a special welding process which Benelli Armi is using for the first time in this sector.

— The magazine release lever, is conveniently located for the thumb making it easy to extract the magazine, without shifting your grip position, while holding the pistol on target.

The sleek, aggressive line of the weapon was studied in every detail to minimize recoil effects such as upward pitching and sideways torque (twisting) in rapid fire. The combined features of low barrel to hand location, natural pointing grip shape, slide buffer system and excellent trigger placement greatly enhance these handling qualities.

— The pistol can be taken apart (field stripped) in just a few seconds without the help of any special tools for a quick cleaning of the essential parts.



4

## Operating description of the delayed blow-back Locking System

The pistol consists of three main assemblies working in conjunction with each other to lock and unlock the weapon:

1. The grip frame and sub frame (with barrel and locking recess for bolt) which are assembled to function as a single unit.
2. The slide with its combination firing pin retaining plate and bolt locking support.
3. The breech bolt and its attached toggle lever.

When the pistol is loaded and ready to fire the recoil spring unit holds the slide fully forward on the frame. In this position the locking support in the rear of the slide, pushing against the toggle lever attached to the breech bolt, has driven the bolt forward and caused the toggle lever to cam the rear of the bolt into its locking recess in the sub frame. At the instant of firing the bolt and frame are locked together. The slide remains inert and has not yet begun to move on its guides relative to the frame. In this high pressure phase the bolt attempts to move backwards to unlock and push the slide to the rear by the toggle lever.

This motion is opposed by the inertia of the slide which also continues to exert a strong downward coming action against the bolt through the toggle lever. By the time the bolt has overcome the slide and toggle lever resistance the pressure has dropped to a safe minimum limit. The toggle lever, no longer supported by the slide, rotates allowing the bolt to disengage the frame recess and unlock. The bolt is then blown to the rear along with the slide by the residual gas pressure. Case extraction, ejection, cocking and reloading follow the conventional method.

Because of the unique action of this pistol, factory ammunition with a muzzle velocity of more than 1320 feet per second (400 meters per second) can be used in complete confidence.

## How the double action works

Fig. 1 Pistol loaded, safety off, hammer uncocked (down), ready to fire double action. In this position the safety can be engaged in the safe position. Moving the manual safety lever upwards by hand brings its attached sear block plate to the outlined position (see arrow).

Fig. 2 Pistol loaded, safety off (down), hammer in double action phase. In this position the hammer is about to be released by the push bar from the double action release pin and sear to strike the firing pin (see arrow).

Fig. 3 Pistol loaded, safety off (down), hammer has fallen in double action phase. In this position the hammer has already struck the firing pin (to discharge the cartridge) after being released from the hammer and sear push bar.

Finger pressure has brought the trigger to the end of its travel. Fig. 4 Pistol loaded, safety off (down), hammer cocked, ready to fire single action. Firing condition after first double action shot. To fire, pull the trigger which forces the push bar to the rear by its trigger pivot until it disengages the single action sear (see arrow) to release the hammer. In this position the safety can be engaged (upwards) as shown in Figure 1, if you do not wish to fire immediately.

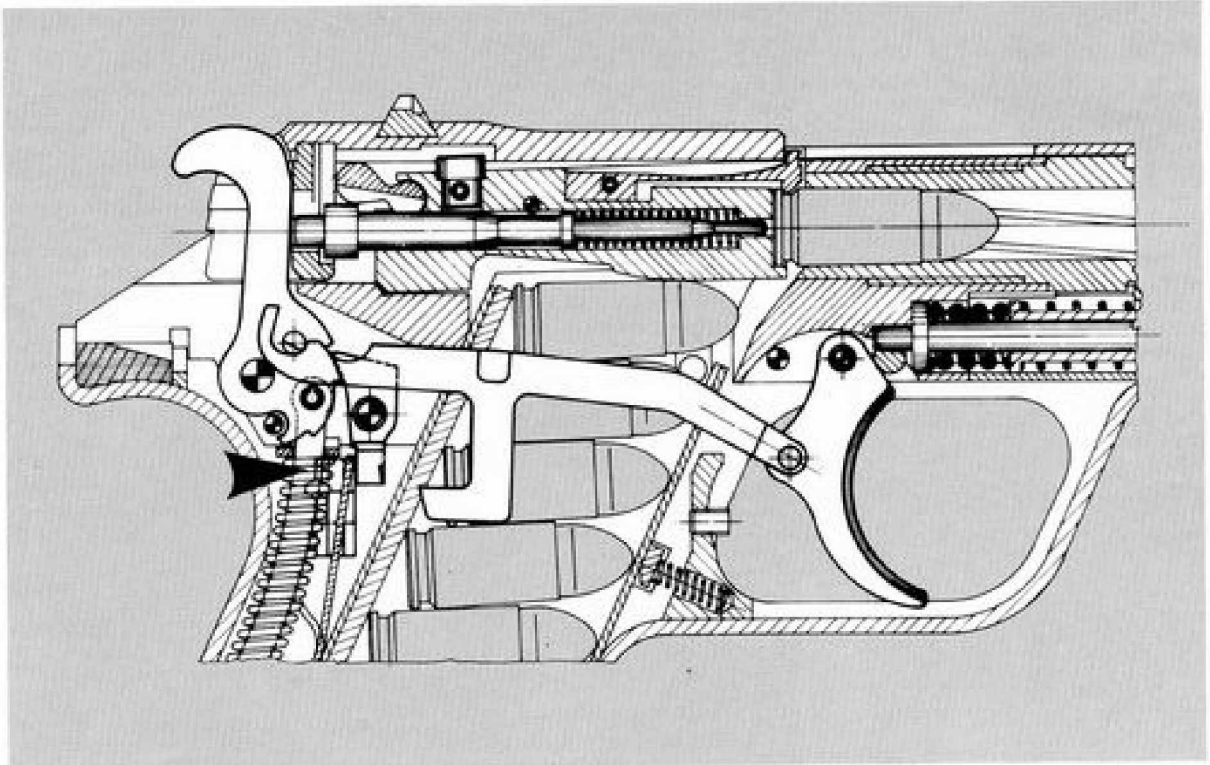


Fig. 1

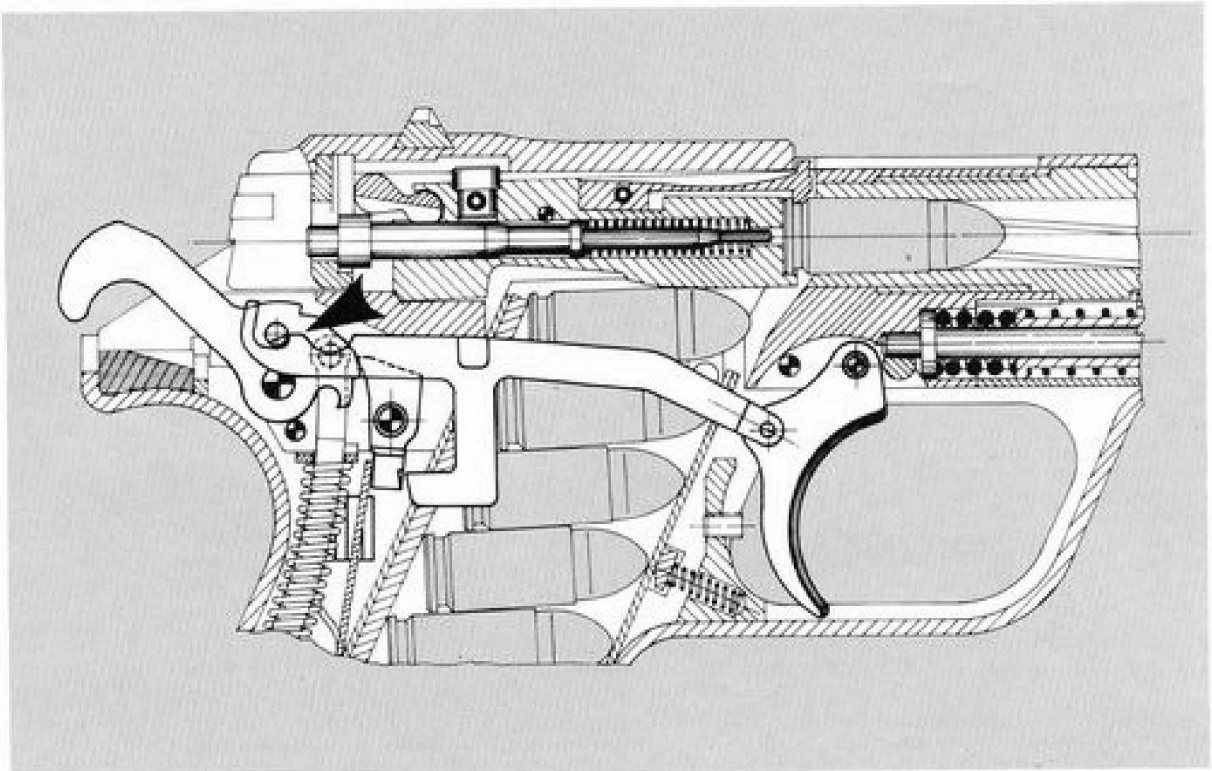


Fig. 2

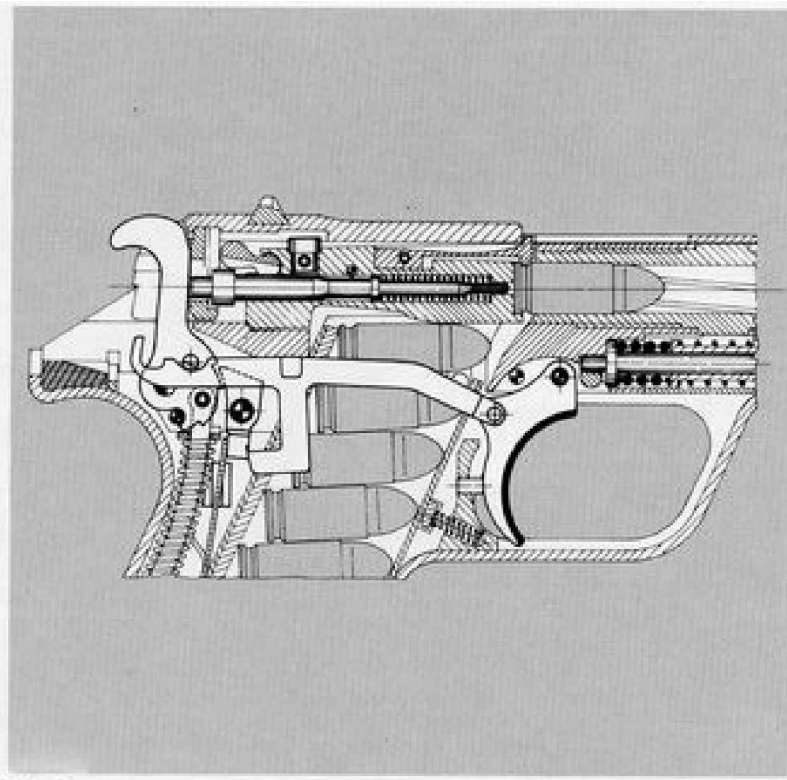


Fig. 3

12

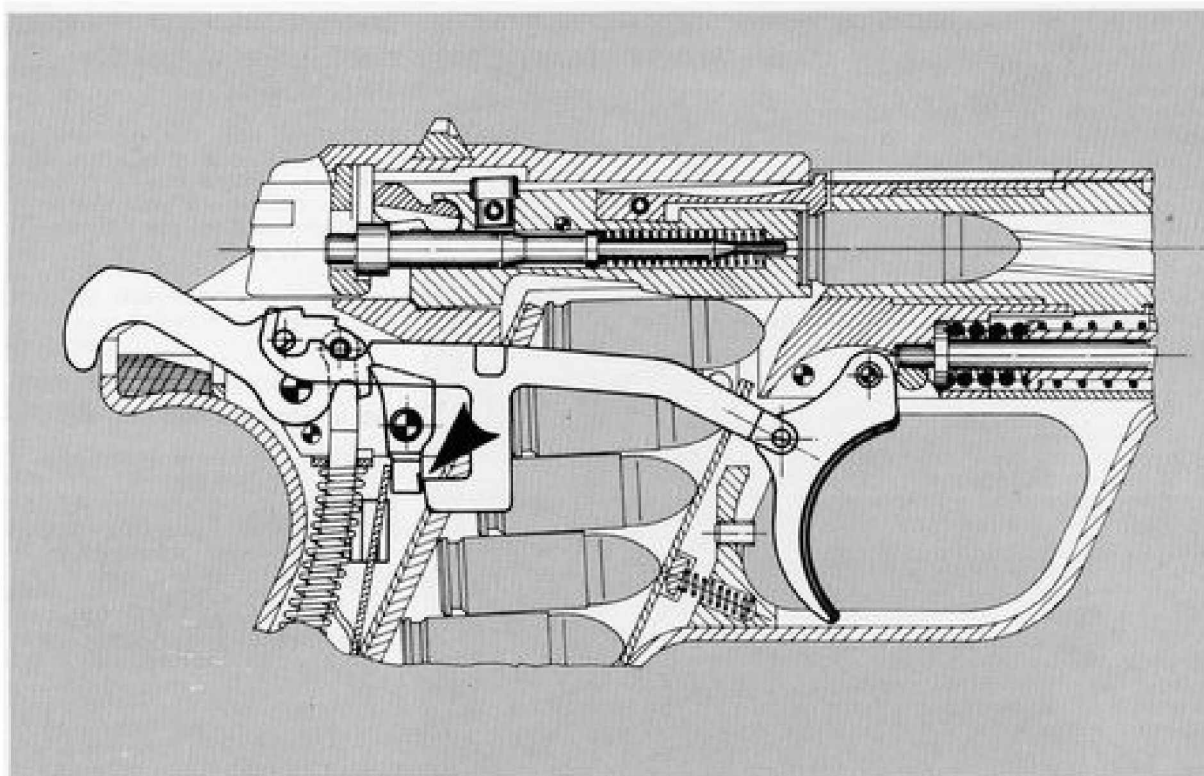


Fig. 4

13

## Instructions for using the Benelli B 76 Pistol

The pistol can be taken apart in a few seconds without any special tools.

Always remember that unless you are actually firing the pistol it must be on safety when in use.

The muzzle of the barrel must always be pointed toward the ground or in another safe direction when not actually shooting.

### Safety

By lowering or raising the safety lever, the safety is disengaged or engaged respectively.

When the red dot is visible, the pistol is in firing condition, (Fig. 5).

When the white dot is visible, the pistol is on safety, (Fig. 6).

In this position the safety lever also blocks the slide.

### Extracting the magazine

(Fig. 7)

Set the pistol on safety; grip the pistol in your firing hand, with your thumb move the magazine release control lever in the direction shown by the arrow in the figure and with your other hand extract the magazine.

### Filling (loading) the magazine

(Fig. 8)

Holding the cartridge by its projectile in your right hand, slip the head of the cartridge under the magazine feed lips while your left hand lowers the cartridge follower by its ears projecting through the magazine tube slots.

The magazine holds eight cartridges maximum.

To empty the magazine, slip out the cartridges one by one by pushing them forward until they are free of the feed lips.

Do not use excessive force when carrying out this operation. Cartridges with defective edges may cause operating problems.

### Loading the pistol

(introducing the first cartridge in the barrel)

I. First Loading Method.

A. Grip the weapon in your firing hand and keep the muzzle of the barrel turned downward.

B. Insert a filled magazine in the pistol until it is engaged by the magazine release catch.

C. Free the slide by moving the safety lever to firing position. Pull the slide fully to the rear, by its grooved rear section, until it stops and then let it snap fully forward.

These operations place the first cartridge of the magazine in the barrel chamber, (Fig. 9).

**Attention!** The hammer of the pistol is cocked and ready to fire.

If the weapon is not used immediately engage the safety or uncock the hammer carefully as described on page 15 and 24.

II. Second Loading Method.

A. Grip the weapon in your firing hand and keep the muzzle of the barrel turned downward.

B. Free the slide by moving the safety lever to the firing position.

C. Pull the slide fully to the rear, by its grooved rear section, while applying upward pressure

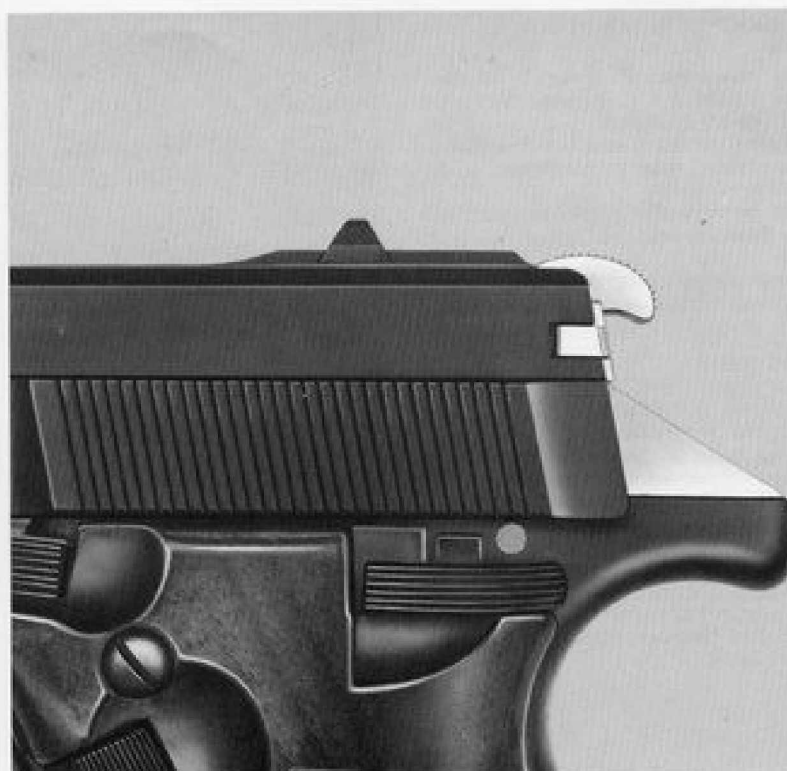


Fig. 5

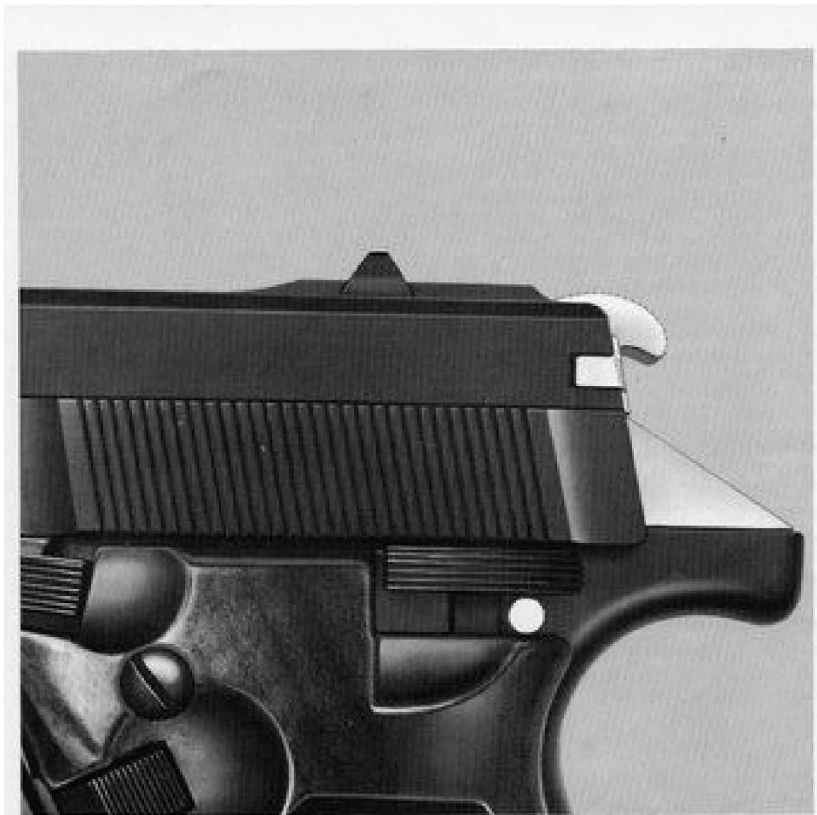


Fig. 6



Fig. 7

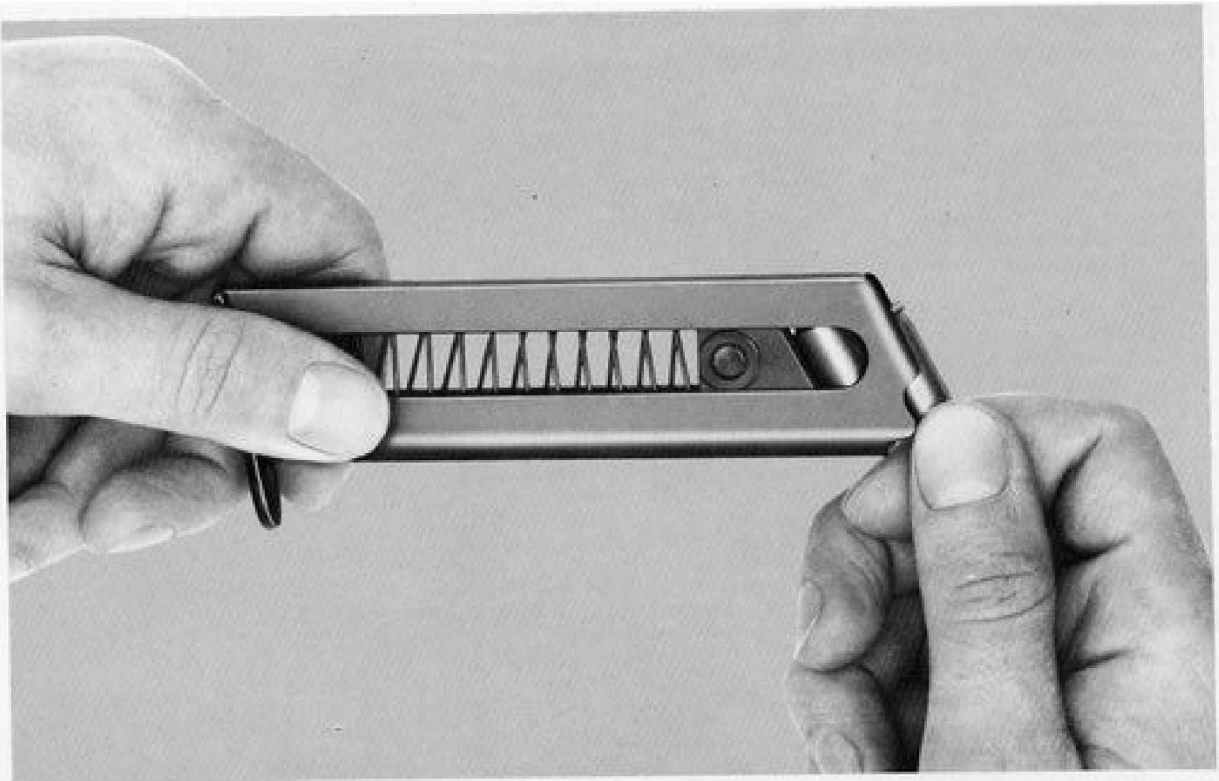


Fig. 8

20



Fig. 9

22



Fig. 10

23

with the thumb against the slide stop lever. This will engage the slide and lock it to the rear.

D. Insert the filled magazine in the pistol until it is engaged by the magazine release catch.

E. Pull the slide back all the way to the rear and let it snap forward; or push the slide stop lever downward to release the slide forward.

In either case the slide snaps forward and places the first cartridge of the magazine in the barrel chamber.

The projecting extractor (Fig. 10) shows that a cartridge is in the barrel.

**Attention!** The hammer of the pistol is cocked and ready to fire. If the pistol is not used immediately, **engage the safety or uncock the hammer carefully** as described on page 15 and 24.

— Reloading when the magazine is empty

After the last shot, the slide remains open (Fig. 11).

To continue firing immediately, simply exchange the empty magazine for a full one and push down the slide stop lever to make the slide snap forward chambering a new cartridge.

The pistol is once again ready to fire with the hammer cocked

and the safety in fire condition.

— Unloading and uncocking the pistol

Remove the magazine (Fig. 5).

Grip the slide by its grooved rear section and pull it back to the open position (Fig. 11).

Make absolutely sure no cartridge remains in the barrel chamber and then ease the slide forward to its closed position.

When carrying out these operations always keep the barrel muzzle pointed downward.

To uncock the pistol (fully lower the hammer), whether loaded or unloaded, hold the weapon in your firing hand, move the safety to fire position, hold the hammer in place with your thumb (Fig. 12), pull the trigger and slowly and carefully accompany the hammer down until it rests completely at the rear end of the slide. An alternate method is to follow the above procedure but use the thumb of the non firing hand to lower the hammer. This allows a more secure grip on the weapon.

To avoid accidental discharge, with arm loaded, make sure never to let go of the hammer until it is in contact with the slide. Always hold the weapon with the muzzle pointed down.

## Firing

— Single action firing; chamber loaded

Set the safety to fire position. To cock the hammer pull it back with your thumb (Fig. 12), until it engages the sear and remains to the rear.

**Attention!** Do not keep your finger on the trigger while cocking the hammer. Any slight pressure on the trigger will cause the hammer to drop and fire the cartridge in the chamber.

— Double action firing; chamber loaded

Grip the weapon in your firing hand. Set the safety in fire position pull the trigger completely to the rear. After the first shot is fired double action the pistol will automatically cock the hammer to fire single action on all succeeding shots.

The smooth performing double-action trigger cocks and releases the hammer to fire the first shot or recocks it in case of misfire. In double action shooting, trigger travel is necessarily longer and the pull weight is greater than single action firing.





Fig. 11



Fig. 12

## Pistol disassembly

Hold the weapon in your firing hand.

Remove the magazine (Fig. 5); with your other hand grip the slide by its grooved rear section and pull the slide back all the way and lock it in this position by pushing the safety lever up with the thumb of your firing hand (Fig. 13).

Make sure there is no cartridge in the barrel chamber.

Hold the pistol in your left hand (Fig. 14), turn both the locking support pawls towards the inside of the locking support piece until they clear their seats machined on the sides of the slide.

The bottom rear of the magazine (floorplate) is designed to fit the slide seats for this purpose.

With any pointed object a (pen, key, nail, etc.) push the firing pin forward, if necessary move the locking support slightly which will easily slide down on its guides to leave the firing pin pushed forward. With your right hand take the locking support and slip it completely off the rear of the slide along the guides (Fig. 15).

Grip the weapon in your firing hand and with the other hand hold the slide and lower the safety lever.

The slide, pushed forward by the recoil spring, will easily come completely free of the sub frame guides (Fig. 16) and off the weapon.

Remove the bolt from its support on the sub frame (Fig. 17) and pull the recoil spring unit forward and off, from its housing (Fig. 18) on the grip frame.

To remove the firing pin and spring; once bolt is free of sub frame, grasp rear of pin and rotate in either direction while applying slight rearward tension.

The firing pin and spring will now come free as well as the bolt toggle lever.

Remove the grip panels by first putting the safety in safe position and carefully remove grip screws. Lift panels gently from bottom (butt section) to clear grip frame. Magazine may be disassembled by depressing the tit protruding from the magazine floor plate hole and sliding the floor plate forward and off. Hold hand over bottom when removing to prevent spring and false floor plate from flying free.

No further disassembly is recommended except by the factory or their authorized agent or a competent gunsmith.

Never release (drop) the hammer freely when the pistol is disassembled.

## Cleaning the Pistol

With the pistol separated into its main parts, field stripped (Fig. 19), it is easy to clean.

The life and performance of your weapon depend basically on proper handling and timely cleaning.

The barrel must be cleaned from the rear after each use with a good powder solvent, barrel brush and cleaning patches. This should be followed by a light film of oil on the bore.

This cleaning consists mainly of eliminating dust and dampness. The polished internal parts must be cleaned with powder solvent and lubricated with a light film of gun oil.

Use only solvent and oil especially prepared for firearms.

## Assembling the Pistol

To assemble the pistol reverse the procedure described for the disassembly. Remember, however, that to assemble the locking support it is not necessary to push the firing pin forward as when disassembling, because the locking support itself pushes the firing pin forward when it is fitted.



Fig. 13

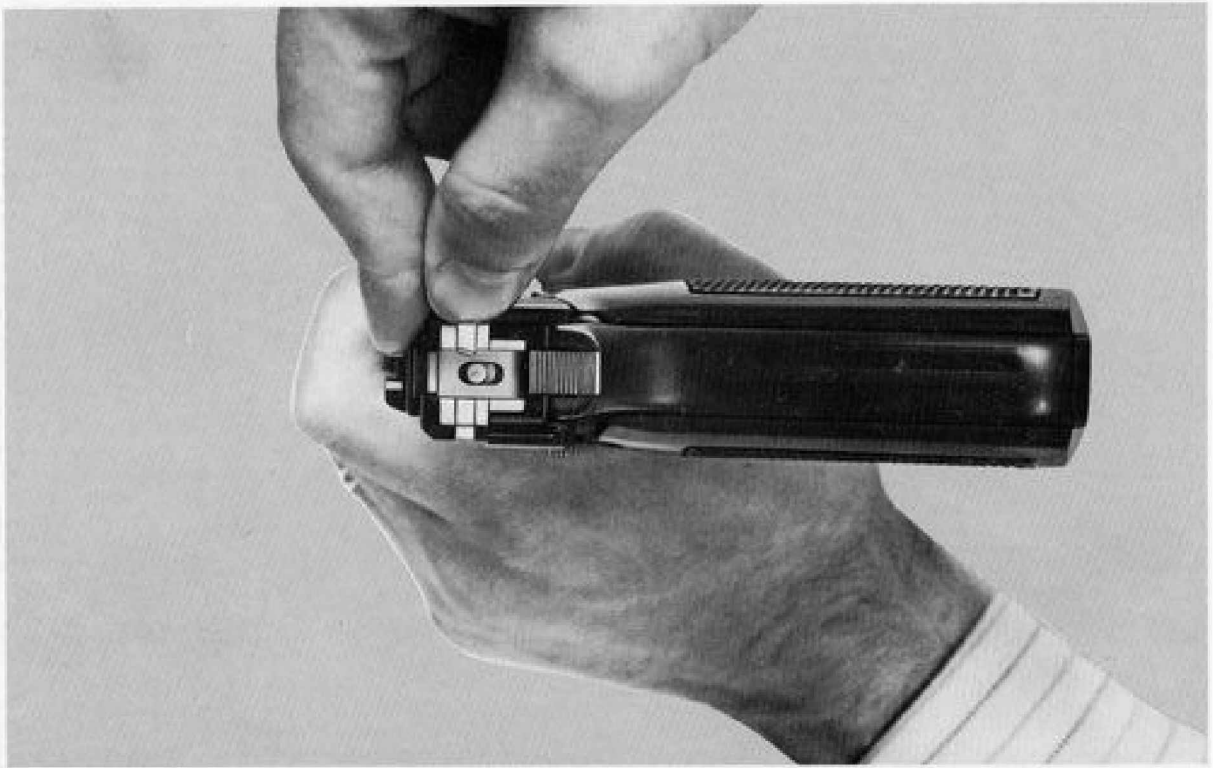


Fig. 14

32



Fig. 15

33



Fig. 16



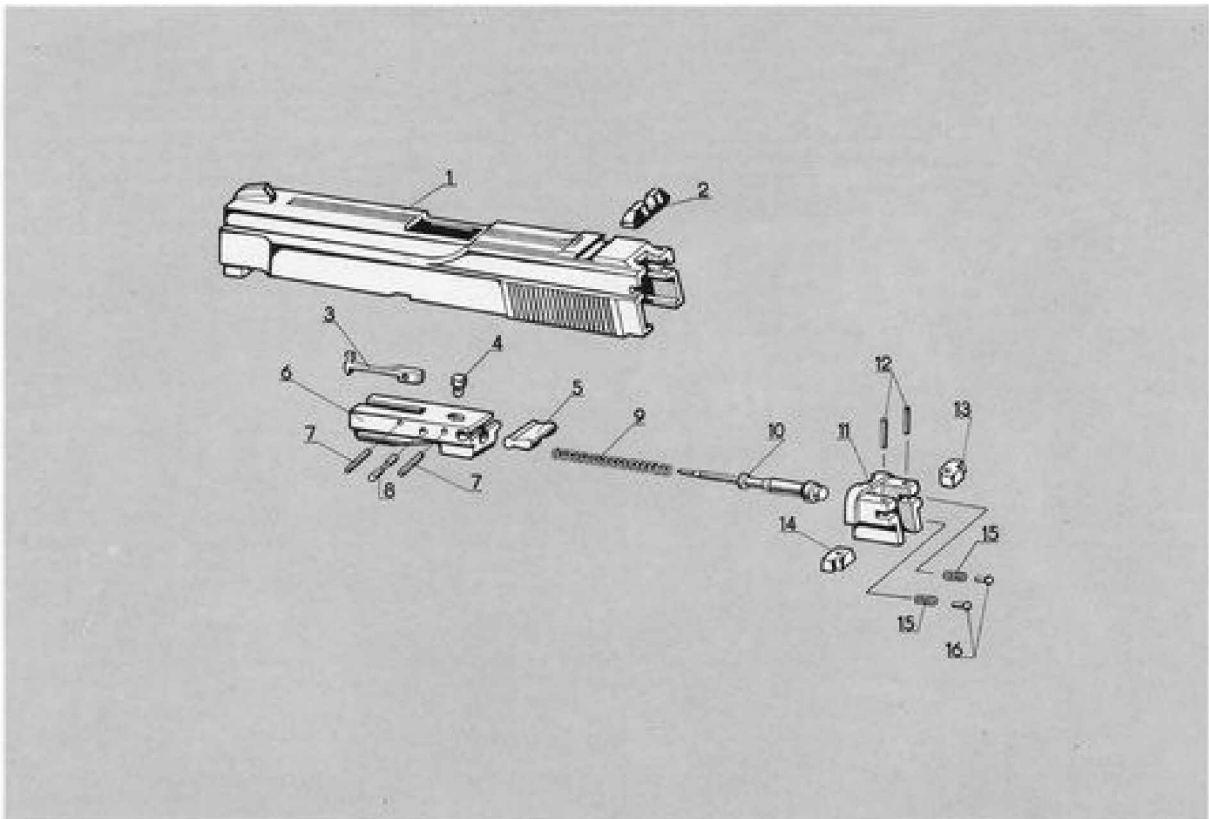
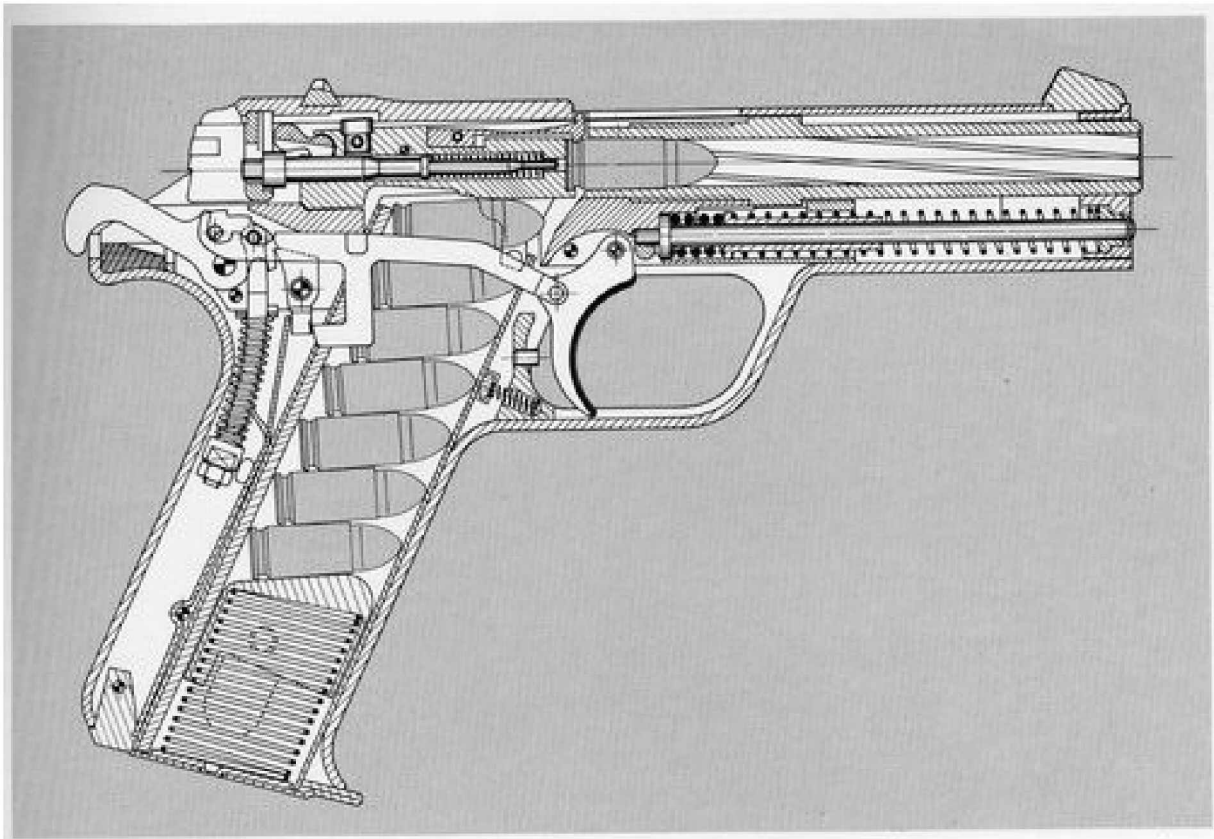
Fig. 17

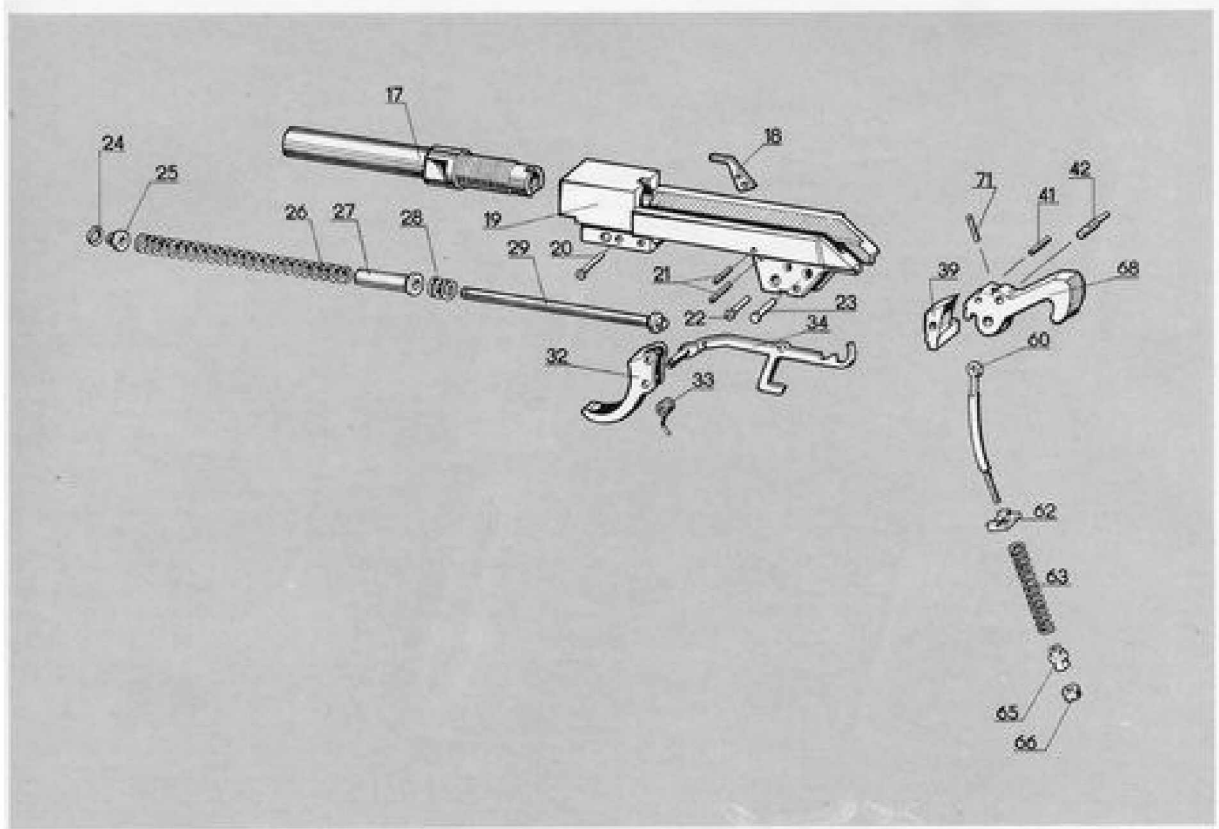


Fig. 18

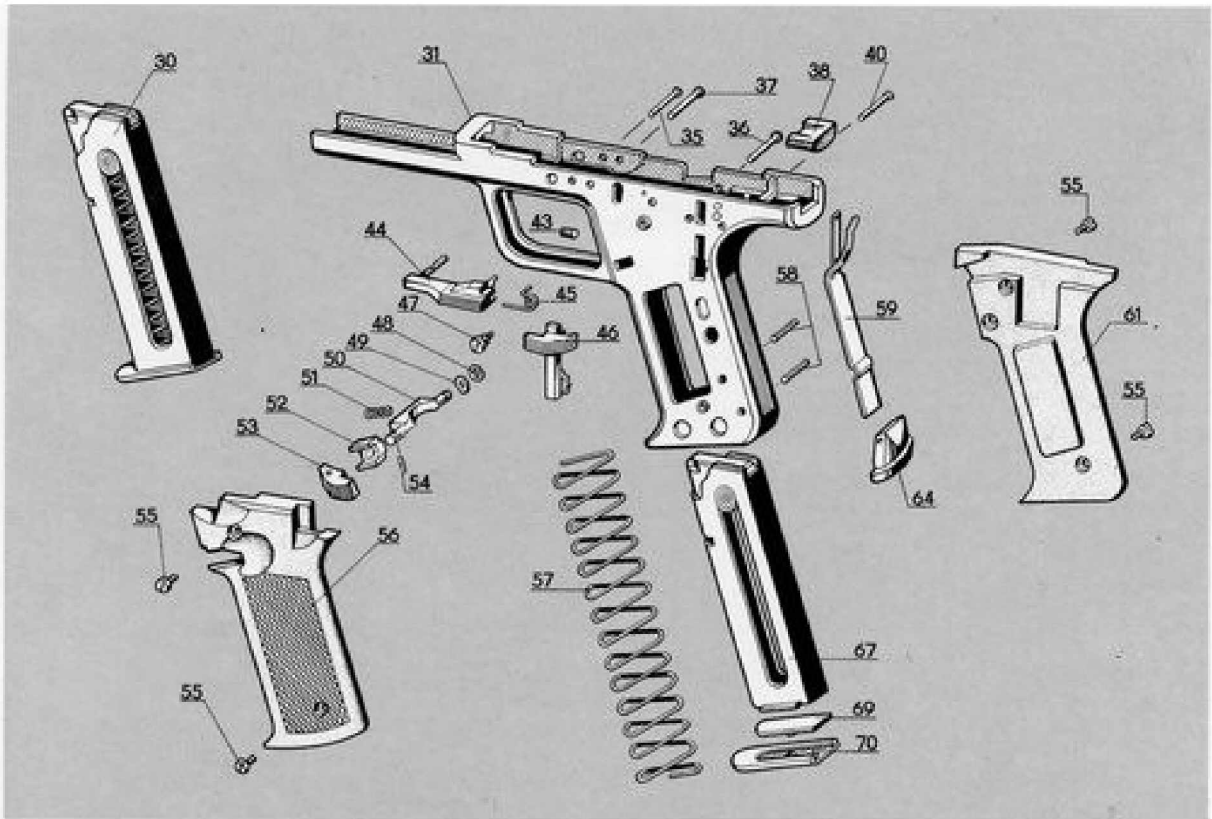


Fig. 19





43



44

**Automatic Pistol  
components**

1	Slide	21	Ejector pin and double action release pin	40	Frame fastening pin	55	Grip screw
2	Rear Sight	22	Sear pivot bushing	41	Hammer strut retaining pin	56	Left hand grip panel
3	Extractor	23	Hammer pivot pin	42	Double action release pin	57	Magazine spring
4	Bolt Control Stud	24	Recoil spring unit retaining clip	43	Self-locking, trigger overtravel adjustment screw	58	Sear and safety spring and frame plug retaining pin
5	Bolt Toggle Lever	25	Recoil spring compression bushing	44	Slide stop (hold open) lever	59	Sear and safety spring
6	Bolt	26	Recoil spring	45	Slide stop lever return spring	60	Hammer strut and spring guide
7	Extractor pin and bolt control stud pin	27	Buffer spring compression bushing	46	Manual thumb safety	61	Right hand grip panel
8	Firing pin retaining pin	28	Buffer spring	47	Screw for slide stop spring	62	Hammer strut and spring guide plate
9	Firing pin spring	29	Recoil spring guide rod	48	Magazine release retaining clip	63	Hammer spring
10	Firing pin	30	Magazine assembly	49	Magazine release spring washer	64	Grip frame back strap plug
11	Firing pin retainer and bolt locking support	31	Grip frame	50	Magazine release	65	Hammer spring tension bushing
12	Pin for locking support catch pawl	32	Trigger	51	Magazine release spring	66	Hammer spring bushing lock nut
13	Right locking support catch pawl	33	Trigger return spring	52	Magazine release control lever guide	67	Magazine body (tube)
14	Left locking support catch pawl	34	Disconnecter and hammer and sear push bar	53	Magazine release control lever	68	Hammer
15	Locking support catch pawl spring	35	Grip frame fastening pin	54	Magazine release pin	69	Magazine false floor plate
16	Spring guide plunger	36	Grip frame fastening pin			70	Magazine floor plate
17	Barrel	37	Grip frame fastening pin			71	Elastic split pin
18	Ejector	38	Hammer buffer				
19	Sub frame (breech unit)	39	Single action sear				
20	Trigger pivot bushing						