

Cannonball Blast



passion in ★ fun out

Service Manual



PLACE SERIAL NUMBER LABEL HERE

FACTORY CONTACT INFORMATION



BAY TEK GAMES INC.
Pulaski Industrial Park
1077 East Glenbrook Drive
Pulaski, WI 54162 U.S.A.
www.baytekgames.com

Our Vision:

We aspire to be the best in the world at developing and manufacturing coin operated games for our customers.

JOIN SERVICE FIRST NETWORK!

This free service is intended to keep you up to date on the latest game information, early notification of parts specials, pertinent technical bulletins, updates on retro fit parts, software upgrades, & much more. Log on to: www.baytekgames.com/parts & then click on the Service First icon.

8 AM - 5 PM C.S.T. MON - FRI



SALES

P: 920.822.3951
F: 920.822.8936
sales@baytekgames.com

PARTS

P: 920.822.3951 x 1101
F: 920.822.1496
parts@baytekgames.com

SERVICE:

P: 920.822.3951 X 1102
F: 920.822.1496
service@baytekgames.com

TABLE OF CONTENTS

FACTORY CONTACT INFORMATION	2
TABLE OF CONTENTS	3
INTRODUCTION	4
INSPECTION	4
DIMENSIONS	5
AIR COMPRESSION REQUIREMENTS	6
SAFETY PRECAUTIONS	6
INSTALLATION COMPONENTS	7
MAIN CABINET COMPONENTS	8
ASSEMBLY ISTRUCTIONS	9/12
HOW TO PLAY	13
PROGRAMMING	14/18
PREVENTATIVE MAINTENANCE SECTION	19
TROUBLE SHOOTING	20/25
SERVICE AND REPAIR	26/28
WIRING DIAGRAMS	29/32
SCHEMATICS	33/40
MAINTENANCE LOG	41
TECHNICAL SUPPORT	42
WARRANTY	43

CANNONBALL BLAST

Arrrggghhh Matey!

Congratulations on your Cannonball Blast purchase!

This piece is sure to serve as a great addition to your existing shooting games, and more importantly, will offer your clientele great entertainment value! We can proudly say our shooting game line up: Horse Play, Cannonball Blast & Sky Masters, is viewed as a staple in family entertainment centers across the globe. And now, because you've made an investment in quality, this pirate ship is ready to make waves at your own location!

We hope you take a few moments to read through this manual, and encourage you to contact the factory with any further questions you may have .

Thank you for your business and we wish you great success!

Your Friends at Bay Tek Games



GAME INSPECTION

Inspect the game for any damaged, loose, or missing parts. If damage is found, please contact your freight carrier first. Then, contact Bay Tek Games Service Department at 920.822.3951 or e-mail them at service@baytekgames.com for further assistance.

IMPORTANT! Complete your new game registration card located inside the cashbox for an additional 3 months FREE WARRANTY!

DIMENSIONS

WEIGHT

Weight: 875 lbs.

Shipping Weight: 1115 lbs.

DIMENSIONS:

47.5" W x 100" D x 88" H

(Without Stools 80" D)



Order with: BAYTEK GAMES PART # AAGM-CBB

AIR COMPRESSION REQUIREMENTS

AIR COMPRESSION (supplied / built into the facility)









1. Set air pressure at the regulator for 70 PSI (4.83 bars)
2. A pneumatic air supply system, with minimum pressure of 85 PSI (5.86 bars), is required to operate this game.
3. A 1/2"- 1/4" pipe reducer has been supplied for the air connection*

AIR COMPRESSORS

1. Each game requires one 20 gallon tank, 2 horsepower, 5-6 cubic feet per minute at 90 PSI. Order part A5AC1003 from Bay Tek parts dept; *220 conversion available*

*Customers must supply any other fittings and/or piping needed.

SAFETY PRECAUTIONS

	DANGER	
DO NOT perform repairs or maintenance on this game with the power ON. Unplug the unit from the wall outlet or shut off the power at the power strip located inside the game cabinet.		
	WARNING	
Use of flammable substances can cause severe burns or serious injury. Always use NON-FLAMMABLE solvents for cleaning. DO NOT use gasoline, kerosene, or thinners.		
	CAUTION	
Lifting heavy objects can cause back, neck, or other injuries. Be sure adequate lifting and moving devices are available when unloading, unpacking, and moving this game.		
	ATTENTION	
Be sure the electrical power matches the game requirements. See the serial number decal located on the back of the game cabinet. Always plug game into a grounded circuit. If the supply cord is damaged, it must be replaced by a special cord or assembly available from the manufacturer or its service		

INSTALLATION COMPONENTS

HARDWARE

You will find the following pieces of hardware in a sealed bag in the cashbox.

- A. 1/4 – 20 x 1-1/2” Bolts
- B. Washers
- C. 5/16" Lock washers
- D. #10 x 5/8 Black wood screws
- E. #10 – 24 x 1/2” Black self-tapping screws
- F. #10 – 32 Nylon Locknuts
- G. #2 Square bit
- H. A5BK7004-1 brackets (4)
- I. 1/2” to 1/4" Pipe Reducer
- J. A5AC7002 Frosted Acrylic
- K. Black Teflon balls (48)

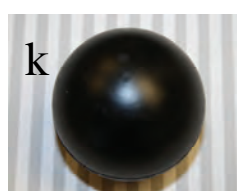
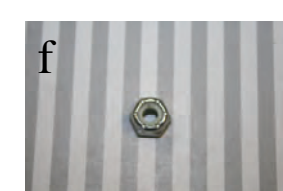
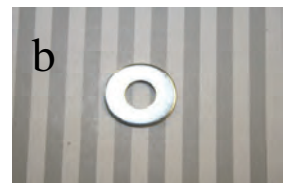
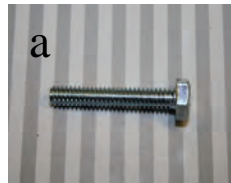

MAIN CABINET COMPONENTS



REAR CABINET



MIDDLE CABINET



FRONT CABINET



MARQUEE



TICKET PLATE BOX

Assembly Instructions

1. Place the rear cabinet near or at its final location.
2. Open the rear cabinet door, uncoil the power cord and feed the cord through the hole. Uncoil other wiring cables. *Do not plug the power cord into the wall outlet at this time.* See figure 1.



3. Move middle cabinet in front of Rear cabinet. Plug in all cables between middle and front, matching connectors. See figure 2.

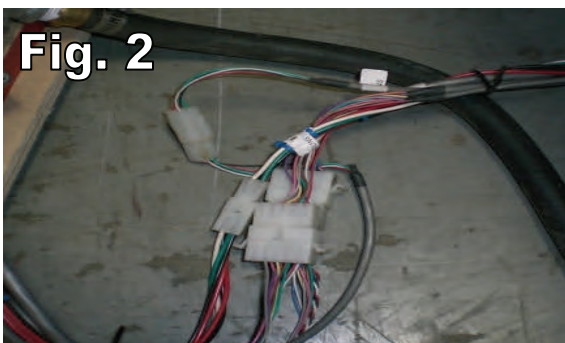

4. Attach the ticket plate box to the middle cabinet using black wood screws (D). Plug in light cable. See figure 3.

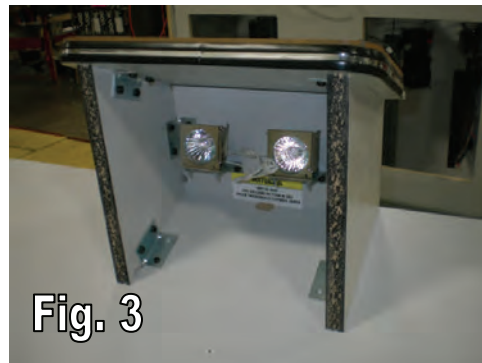

- a. Peel the paper coating off of the frosted acrylic piece and attach to the back of the ticket plate box with black wood screws (D).
5. Install the metal screens.
 - a. Install the middle screen by placing it over the two threaded studs on the ball grate. Secure with two nylon locknuts (F). You will need a 3/8" socket. See figure 5.



- b. Attach the front of the screen to the ramp with two black wood screws (D).

Assembly Instructions

6. Install the outer metal screens. They are marked left and right. Place the screens on the middle cabinet frame and push tight up against the rear cabinet. See figure 6.

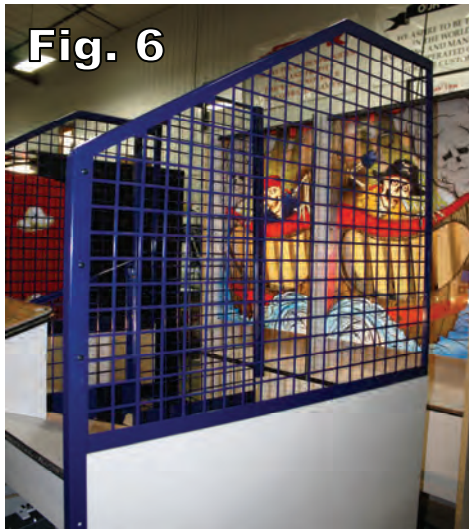

Fig. 6

- c. Install the two top rails which overlap the tops of the outside screens and the rear cabinet. Attach the front of the rails to the screens using 4 black self-tapping screws (E). Attach the rails to the recessed nuts in the top of the cabinet with bolts (A) and lock washers (C). Secure remaining holes with 6 black wood screws (D).

7. Push the middle and rear cabinets together, securing both left and right sides with brackets (H), attaching with bolts (A), lock washers (C) and flat washers (B).

Be careful not to pinch any wiring.
See figure 4

- a. The grates in the bottom of the middle cabinet attach to the rear cabinet with 6 black wood screws (D).
- b. Secure the vertical legs of the screens to the front of the middle cabinet with 16 black wood screws (D). Secure the screen to the horizontal edge of the cabinet with 6 black wood screws (D) through holes on the inside of the screen frame.

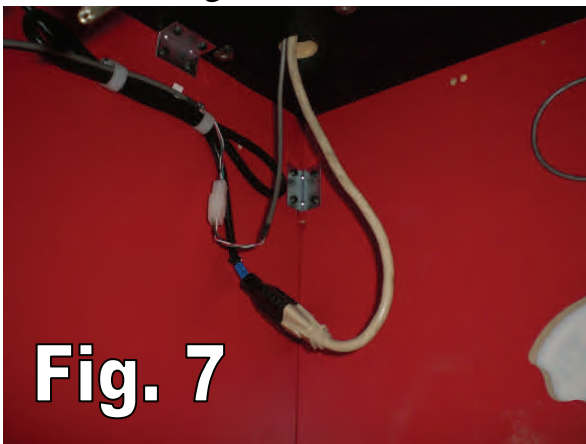

Fig. 4

Assembly Instructions

8. Install the Marquee

- a. Position the marquee on top of the metal rails and pass the power cord and speaker cable through the hole and plug in. See figure 7.



- b. Secure the marquee to recessed nuts in the top of the rear cabinet with 4 bolts (A) and lock washers (C). See figure 8.

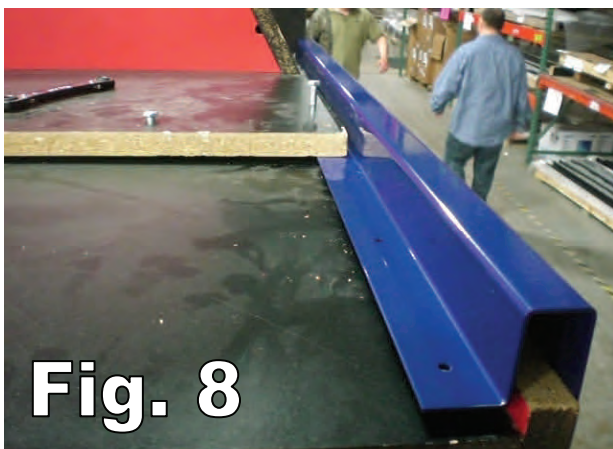

- c. Secure the middle screen to the marquee with 2 black wood screws (D). See figure 9

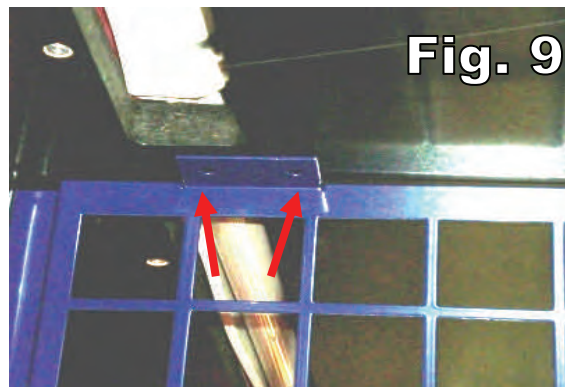

9. Install the Front Cabinet

Position the front cabinet near the middle cabinet. Uncoil and pull the air hose through the middle cabinet and out the hole in the bottom of the rear cabinet.

- a. Tip the cabinet to align and install the dowel pins in the stool bases with holes in the bottom of the cabinet, and attach the seat.
- b. Plug all cable connectors from the middle cabinet into plugs in the front cabinet. Plug the gray phone cable into left cable socket on the main board.
- c. Connect the cabinets together with blue brackets, securing with 2 bolts (A) and lock washers (C).
- d. Attach air hose to the building's air supply or portable air compressor. Set the air pressure regulator to 70 PSI (4.83 bars).

Assembly Instructions

10. Fill the ticket tray. The 'low' ticket light will illuminate when there is approximately 1 1/2 stacks of tickets left in the ticket tray.
11. Inside each front door will be a bag of 8 balls. Empty one bag into each side of the ramp. Both barrels are pre-loaded with 16 balls.
12. Plug the power cord into the wall outlet and turn on the power strip.

Ball Maintenance

Rubber Balls

The black rubber balls are coated with Teflon® to increase the life of the ball. While very durable, the coating will eventually wear off and the rubber material will then begin to wear rapidly. As the balls wear down they will not provide a good seal in the firing tube and miss-fires will occur. This can be corrected somewhat by increased air pressure to the fire cylinder, but at some point it will be necessary to replace the balls due to wear.



WARNING: The ball chute air cylinder can pinch, cut or sever fingers during ball removal. Insure air pressure is OFF and system pressure is released before attempting to remove balls from the lift system.

TO REPLACE BALLS

Turn off the air supply shut off valve located in the front cabinet. Release the air system pressure by firing the gun once. Pull toggle to release the balls. Use a short stick to push the balls out into the chute where they can be removed. See figure 10

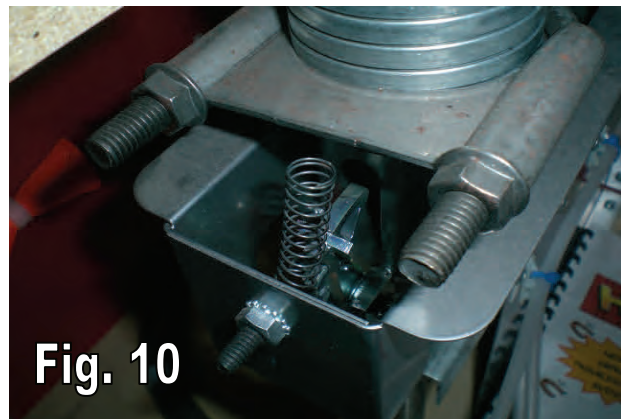

Fig. 10

HOW TO PLAY CANNONBALL BLAST

Players have fun shooting balls at the pirate ship in hopes of knocking down the wooden planks. Knock down all six planks in three shots or less and get a chance at the bonus by hitting all six planks again with the remaining shots!



6 PLANKS →



NOTE: Hitting the planks slightly will not score a hit. The planks need to be knocked down fully. Also, there is a 2.5 second delay before each ball can be shot. If the game does not register a shot after three minutes, the game ends and all credits clear.

The score table, dip switch selectable, should match the tickets owed decal on the game panel (shown below)

Aaarrhh Matey...		2
Knock Down the Planks On the Pirate Ship		Per Play
To Win Yerself Some Tickets!		
You Get	6 Shots	
0-1	8 Tickets	
2-3	12 Tickets	
4-5	16 Tickets	
6	20 Tickets	
BONUS		
Knock Down All 6 Planks		
In 3 Shots Or Less		
Planks Will Reset		
Knock Down All 6 Planks		
With the Remaining Shots		
Win		
		50
		Bonus Tickets!

Factory default as shown

Programming Section

The number of coins required for each game credit, free play, number of balls per credit, tickets payout, etc., are programmable by dipswitches located on the main circuit board.

The main circuit board is located on the inside back wall of the cabinet. Be sure power is off before setting these switches.

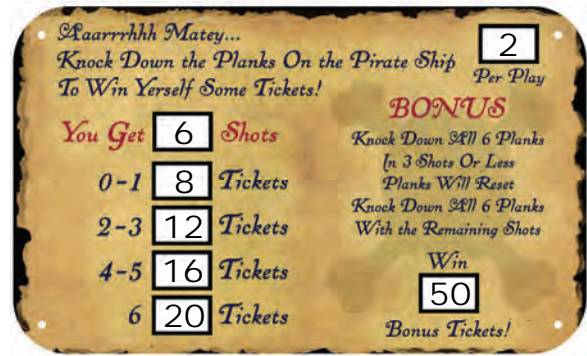

Factory Settings Bank 1

Dip 1	Dip 2	Dip 3	Dip 4	Dip 5	Dip 6	Dip 7	Dip 8
ON	OFF	ON	OFF	OFF	ON	ON	OFF

Factory Settings Bank 2

Dip 1	Dip 2	Dip 3	Dip 4	Dip 5	Dip 6	Dip 7	Dip 8
OFF	OFF	ON	OFF	OFF	OFF	OFF	OFF

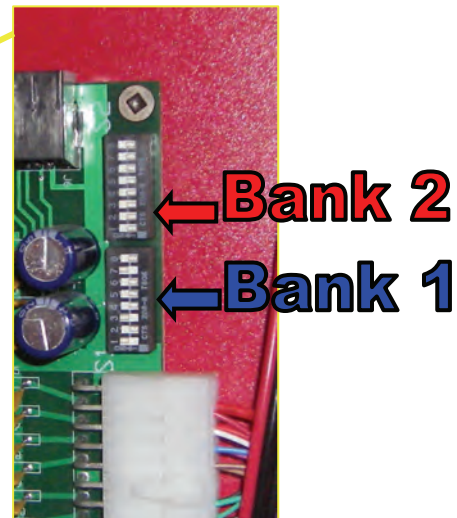
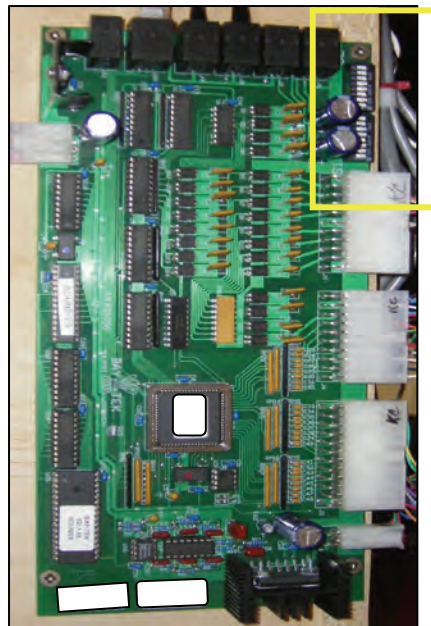

IMPORTANT! Power must be OFF to the game when setting dipswitches. Turn OFF the power strip inside the cabinet. Set the dipswitches to the desired settings, wait 30 seconds and then turn ON power at the power strip.

PROGRAMMABLE SETTINGS

TICKET PAYOUT

ALLOWS YOU TO CHOOSE BETWEEN A SELECTABLE TICKET TABLE (SEE TICKET PATTERNS) OR A FIXED TICKET TABLE

BANK 2	DIP 6
SELECTABLE TICKET PATTERNS (factory default)	OFF
FIXED TICKET PATTERN	ON

SELECTABLE TICKET PATTERNS

***** Ticket amounts are multiplied by credits per play *****

IF YOU CHOOSE TO USE A SELECTABLE TICKET PATTERN, USE THE FOLLOWING CHART TO SELECT WHICH PATTERN YOU WOULD LIKE TO USE.

PAT-TERN	PLANK	TICKETS	PLANK	TICKETS	BANK 1 DIP 1	BANK 1 DIP 2	BANK 1 DIP 3
1	0 TO 1	1	4 TO 5	3	OFF	OFF	OFF
	2 TO 3	2	6	4			
2	0 TO 1	1	4 TO 5	5	OFF	OFF	ON
	2 TO 3	2	6	6			
3	0 TO 1	2	4 TO 5	6	OFF	ON	OFF
	2 TO 3	4	6	8			
4	0 TO 1	3	4 TO 5	5	OFF	ON	ON
	2 TO 3	4	6	6			
5	0 TO 1	3	4 TO 5	7	ON	OFF	OFF
	2 TO 3	5	6	9			
6	0 TO 1	4	4 TO 5	8	ON	OFF	ON
	2 TO 3	6	6	10			
7	0 TO 1	4	4 TO 5	12	ON	ON	OFF
	2 TO 3	8	6	16			

PROGRAMMABLE SETTINGS

FIXED TICKET PAYOUT

IF YOU CHOOSE A FIXED TICKET PATTERN, CHOOSE ONE OF THE FOLLOWING PATTERNS. NOTE: THE PLAYER MAY PLAY THE BONUS ROUND IF IT IS ACHIEVED, BUT NO BONUS TICKETS WILL BE WON.

FIXED TICKETS	BANK 1 DIP 1	BANK 1 DIP 2	BANK 1 DIP 3
1	OFF	OFF	OFF
2	OFF	OFF	ON
3	OFF	ON	OFF
4	OFF	ON	ON
5	ON	OFF	OFF
6	ON	OFF	ON
7	ON	ON	OFF
8	ON	ON	ON

BONUS TICKETS

SET THE NUMBER OF BONUS TICKETS TO BE DISPENSED IN THE BONUS ROUND

BONUS TICKETS	BANK 1 DIP 4	BANK 1 DIP 5	BANK 1 DIP 6
25	OFF	OFF	OFF
50 (factory default)	OFF	OFF	ON
75	OFF	ON	ON
100	ON	OFF	OFF
150	ON	OFF	OFF
200	ON	OFF	ON
250	ON	ON	OFF
300	ON	ON	ON

PROGRAMMABLE SETTINGS

CREDITS PER PLAY

SET THE NUMBER OF COIN/CREDITS PER GAME.

CREDITS	BANK 2 DIP 1	BANK 2 DIP 2	BANK 2 DIP 3
1	OFF	OFF	OFF
2 (factory default)	OFF	OFF	ON
3	OFF	ON	OFF
4	OFF	ON	ON
5	ON	OFF	OFF
6	ON	OFF	ON
FREE PLAY	ON	ON	OFF
8	ON	ON	ON

ATTRACT MODE

WHEN THE GAME IS NOT IN PLAY, AN ATTRACT AUDIO MODE LOOPS TO ATTRACT PLAYERS

BANK 1	DIP 7
ENABLED (factory default)	ON
DISABLED	OFF

CLEAR EEPROM

ALLOWS YOU TO CLEAR ANY UNUSED CREDITS AND TICKET OWED. FIRST TURN GAME OFF. SET DIP TO ON. TURN GAME ON AND WAIT FOR 10 SECONDS. TURN GAME OFF. TURN DIP OFF

BANK 2	DIP 7
ENABLED	ON
DISABLED	OFF

PROGRAMMABLE SETTINGS

NOT USED	
THIS DIP IS NOT USED AND SHOULD REMAIN IN THE OFF POSITION	
BANK 1	DIP 8
ENABLED	ON
DISABLED	OFF

NOT USED	
THIS DIP IS NOT USED AND SHOULD REMAIN IN THE OFF POSITION	
BANK 2	DIP 4,5,6
ENABLED	ON
DISABLED	OFF

Maintenance Chart

Use the following maintenance chart as a guide only. Actual maintenance intervals will depend on usage and environmental conditions at the location of the game.

Keep a log of all inspections, even if no problem exists, with date and time of inspection, action taken. A sample Repair Record is located at the end of this manual.

IMPORTANT: Do not use cleaning solvents on game graphics. Use only a mild soap solution and dry with a clean lint free cloth.

IMPORTANT: Use glass cleaner and a soft clean cloth to clean all the acrylic and metal surfaces on the game. Use an anti-static cleaner polisher on the black ramp surface to protect it and keep it slippery. **IMPORTANT:** The game should be shut OFF for cleaning and maintenance.

CAUTION: Use of flammable substances can cause severe burns or personal injury. Always use non-flammable solvents for cleaning parts and surfaces of this game. Do not use flammable substances such as gasoline, kerosene or thinners.



TASK	DAILY	WEEKLY	MONTHLY
Fill ticket tray.	✓		
Empty coin box.	✓		
Play the game to ensure it is working properly.	✓		
Inspect air system to ensure pressure is set between 40-50 PSI	✓		
Clean outside surfaces and stools. Balls leave black marks on surfaces.	✓		
Inspect the game for physical damage. Repair as needed.		✓	
Inspect game lighting, replace lamps as needed.		✓	
Clean outside surfaces.		✓	
Clean the ticket dispenser with compressed air. Clean the opto sensor using a cotton swab and isopropyl alcohol.		✓	
Clean and vacuum ball track.		✓	
Check to ensure correct number of balls are present.		✓	
Check all hardware for tightness.			✓
Check balls for wear.			✓
Non-filtered air pump: drain water from hoses.			✓
Clean gun barrels with compressed air.			✓

TROUBLESHOOTING GUIDE AND DIAGNOSTIC SECTION

<p>No power to the game.</p>	<p>a. Unplugged. b. Blown fuse c. Outlet strip or building circuit breaker tripped. d. Bad power supply.</p>	<p>a. Check wall outlet. b. Check transformer fuse (220v applications only). c. Check voltage at outlets. Try to determine cause then reset the circuit breaker. d. See power supply diagnostic. Replace if faulty. (A5PS1001)</p>
<p>No Audio</p>	<p>a. Volume too low. b. Loose wire. c. Defective Potentiometer. d. Main circuit board malfunction.</p>	<p>a. Increase the volume at the volume control at the inside of the front door panel. b. Check audio cable connections to speaker, volume control and main circuit board. c. Replace pot. (A5PO1K) d. Replace main board with board from another Gen 5 game if possible to isolate the problem to the main circuit board.</p>
<p>Orange low ticket light on.</p>	<p>a. Ticket tray empty. b. Faulty low ticket switch. c. Broken/loose wires.</p>	<p>a. Load tickets. Make sure ticket stack rests on top of wire actuator of switch. b. Replace switch. (AASW200) c. Check cable connections from switch to main circuit board.</p>
<p>Teeth will not reset. Game will only try to reset teeth once. Then it will error out and not try again until game powered down, then on.</p>	<p>a. In-line fuse blown. b. Motor faulty. c. Linkage problem. d. Power game off and then back on and see if it turn the 1st time.</p>	<p>a. Replace fuse located in the wiring near the main circuit board. b. Replace motor. (AAMO3901) c. Inspect the linkage between the reset arm and gear motor. Check connector cam setscrew, ensure it is tight. d. If it turns that 1st time – then refer to “teeth reset bar rotates</p>

TROUBLESHOOTING GUIDE AND DIAGNOSTIC SECTION

Teeth reset bar rotates up multiple times.	<ul style="list-style-type: none"> a. Motor home sensor dirty or faulty. b. White cam is dirty or too far away from sensor. c. Faulty/broken wires. d. Faulty main board. 	<ul style="list-style-type: none"> a. Clean sensor, replace if necessary. (AABD5010) b. Clean cam. Measure 5 Volts DC when cam is away from sensor, and it drops to 0 Volts when cam is covering sensor. c. Check cable connections from sensor to main circuit board. d. Replace main board with board from another Gen 5 game if possible to isolate the problem to the main circuit board 	
Game does not score.	<ul style="list-style-type: none"> a. Teeth opto's dirty, misaligned, or faulty. b. Faulty/broken wires. 	<ul style="list-style-type: none"> a. Clean, align, or replace opto boards. (AASE3900) b. Check cable connections from sensors to main circuit board. Look at where there are 2 wires crimped to one terminal. Ensure both wires are making connection with the termi- 	
Game does not coin up.	Coin switch problem	<ul style="list-style-type: none"> a. Coin switch faulty. b. Bad connection or broken coin switch wire. c. Faulty main board. 	<ul style="list-style-type: none"> a. Check that coin actually triggers switch. Replace switch if necessary. (A5SW4000) b. Check connections from coin switch to main circuit board. c. Replace main board with board from another Gen 5 game if possible to isolate the problem to the main circuit board.
	Teeth sensor or motor problem.	<ul style="list-style-type: none"> a. Reset motor problem. b. Teeth sensor problem. c. Motor home position sensor dirty or faulty. 	<ul style="list-style-type: none"> a. Refer to "Teeth do not reset" section. b. Refer to "Game does not score" section c. Clean opto sensor and white cam that the sensor looks at. Replace sensor if necessary. (AABD5010)

TROUBLESHOOTING GUIDE AND DIAGNOSTIC SECTION

<p>No air blast out of cannon.</p>	<p>a. No air pressure. b. Incorrect air pressure. c. Trigger not working. d. Boom valve faulty. e. Bad connection or broken wire. f. Faulty main board.</p>	<p>a. Check air line, air compressor. Ensure gauge on air line input is working. b. Adjust compressor to output 90 PSI. Adjust game air pressure to 50 – 55 PSI. c. Check trigger button, wires to main board. Replace switch (A5PB7100) by removing barrel from gun, reach inside and remove right handle. Switch is then accessible. d. Check for 12 Volt DC pulse at boom valve. Replace boom valve (A5VA7100) if pulse is present. Check wire continuity back to main board if no pulse. e. Check connections from boom valve and trigger to main circuit board. f. Replace main board with board from another Gen 5 game if possible to isolate the problem to the main circuit board.</p>
<p>Wrong number of tickets dispensed.</p>	<p>a. Ticket Pattern or other ticket dipswitches set wrong. b. Dirty opto-sensor on ticket dispenser. c. Many tickets in memory. If ticket meter is counting the tickets coming out, then reset tickets owed. d. Faulty ticket dispenser. e. Main circuit board malfunction.</p>	<p>a. Check and reset dipswitches for proper setting. b. Clean with compressed air or wipe with isopropyl alcohol on a cotton swab. c. Loop tickets and let dispenser run. Or remove memory chip from main board. Position U3. Leave chip out of board and turn power on game. The game can run fine with this chip removed. d. Replace with spare working dispenser. e. Replace main board with a spare Gen 5 board if possible to isolate the problem to the main circuit board.</p>

TROUBLESHOOTING GUIDE AND DIAGNOSTIC SECTION

<p>Balls misfire or shoot 2 at a time.</p>	<p>a. Not enough balls in flex tube.</p> <p>b. Balls stuck in return chute or flex tube.</p> <p>c. Ball height in flex tube not adjusted correctly.</p> <p>d. Ball gate (cup lifter) broken.</p> <p>e. Pawl spring is not holding the ball above lit cylinder.</p> <p>f. Balls worn. Does not have a tight seal in cannon.</p>	<p>a. Check both sides of game. Ensure both sides have at least 25 balls.</p> <p>b. Check for debris in ball return chute. Ensure lifter is operating correctly.</p> <p>c. Look down barrel of gun. The ball to be fired next should be directly in front of nozzle. This position can be adjusted by bending flex tube. If ball is too high – bend flex tube. If ball is too low – straighten flex tube.</p> <p>d. Ensure cupped ball gate has 2 rods coming down. One attached to lift cylinder, one as a guide. If one is broken, replace gate. (A5GA7100)</p> <p>e. Replace pawl and spring. (A5PA7100 and A5SP7100)</p> <p>f. Old balls do not shoot properly. Replace balls. (AABALL-ALL)</p>
<p>Ball lift cylinder is not lifting up all the way.</p>	<p>a. Water and/or Oil in the air line.</p> <p>b. Pawl / Spring combination jamming balls.</p> <p>c. Defective ball lift cylinder.</p> <p>d. Mac Valve improperly set.</p> <p>e. Defective Mac Valve.</p>	<p>a. Turn off air. Remove air hoses to ball lift cylinder. If water drains out, an air dryer/filter must be added to air system.</p> <p>b. Replace pawl (A5PA7100) and/or spring.(A5SP7100)</p> <p>c. Replace ball lift cylinder. (A5BL7101)</p> <p>d. To increase lift up speed – Follow the air line from the bottom of the lift cylinder to the blue Mac valve. Loosen the lock nut on the screw that corresponds to this air line. Increase air flow by turning screw clockwise. Adjust slightly, firing the cannon 3 times before further adjustments. Once set correctly, re-tighten lock nut.</p> <p>e. Replace Mac Valve. (A5VA7103)</p>

TROUBLESHOOTING GUIDE AND DIAGNOSTIC SECTION

<p>Ball lift cylinder is not dropping down all the way.</p>	<ul style="list-style-type: none"> a. Water and/or Oil in the air line. b. Ball gate (cup lifter) broken. c. Defective ball lift cylinder. d. Mac Valve improperly set. e. Defective Mac Valve. 	<ul style="list-style-type: none"> a. Turn off air. Remove air hoses to ball lift cylinder. If water drains out, an air dryer/ filter must be added to air system. b. Replace ball gate. (A5GA7100) c. Replace ball lift cylinder. (A5BL7101) d. To increase down speed – Follow the air line from the top of the lift cylinder to the blue Mac valve. Loosen the lock nut on the screw that corresponds to this air line. Increase air flow by turning screw clockwise. Adjust slightly, firing the cannon 3 times before further adjustments. Once set correctly, re-tighten lock nut. e. Replace Mac Valve
<p>Tickets do not dispense.</p>	<ul style="list-style-type: none"> a. Ticket tray empty due to faulty low ticket sensor switch or broken/loose wires. Sensor switch stuck or switch wire bent out of position. b. Faulty cable to dispenser. c. Dirty opto-sensor or paper dust buildup in ticket dispenser. d. Notch on tickets too shallow. e. Ticket dispenser faulty. f. Main circuit board malfunction. 	<ul style="list-style-type: none"> a. Fill ticket tray. Replace low ticket sensor switch. Repair wiring. Clean ticket tray of dirt and loose tickets or debris. Bend switch wire to correct position under tickets. b. Check wiring continuity from dispenser to main board. Check for pinched, broken or disconnected wires. Replace as necessary. c. Clean with compressed air and if necessary wipe sensor with isopropyl alcohol on a cotton swab. d. Flip tickets and load upside-down to have large cut notch toward opto sensor. e. Replace dispenser with spare working dispenser. f. Replace main board with a spare Gen 5 board if possible to isolate the problem to the main circuit board.

Power Supply Troubleshooting

Use the following procedure to check the power supply for Gen 5 games.

Check the small green LED light on the power supply circuit board. If the light is out there is a short somewhere. If the light dims, there is an overload in one of the circuits such as a bad motor.

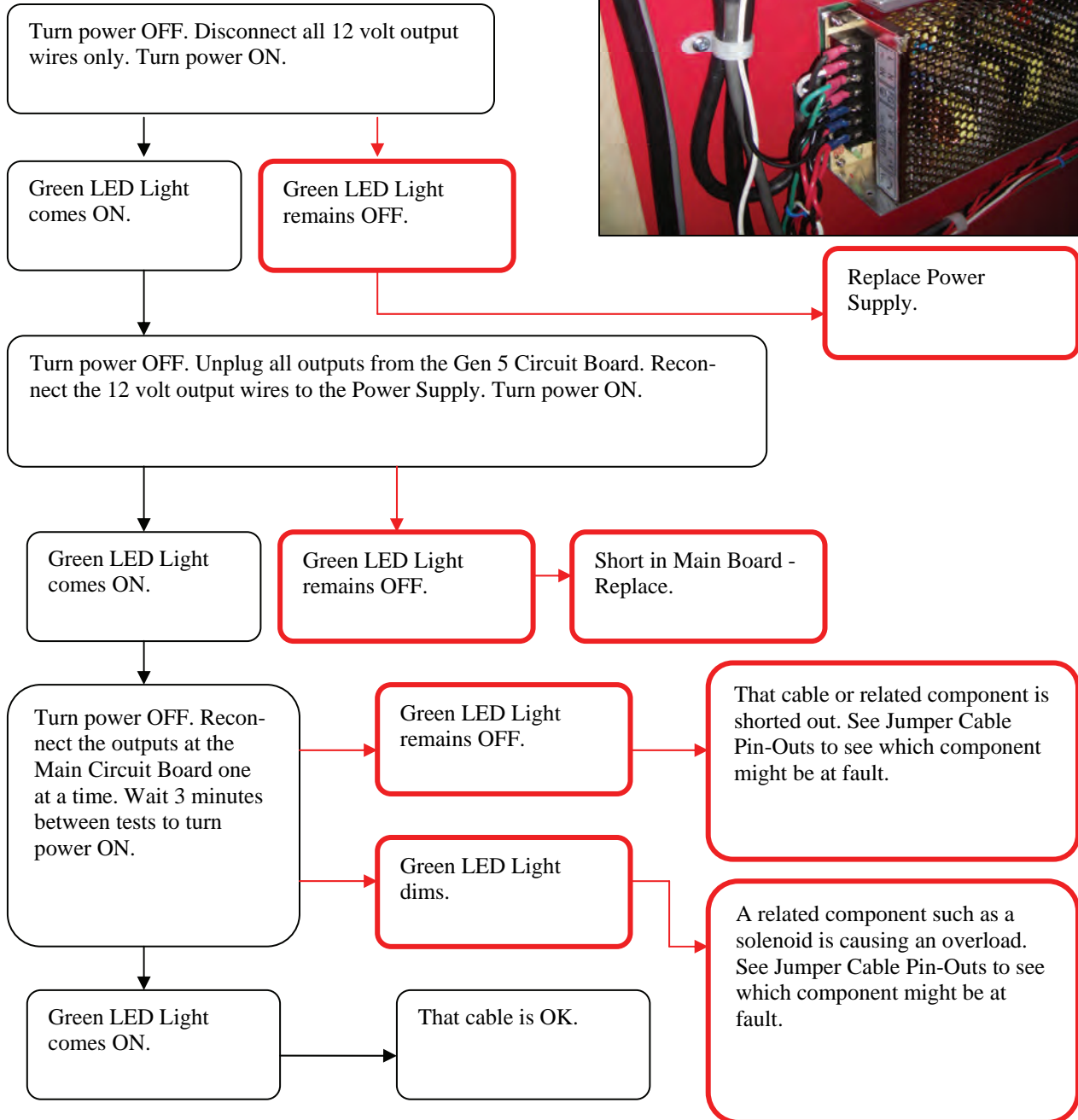

Service and Repair Section



CAUTION: Static electricity could harm circuit boards and processor chips. Always ground yourself by cable or by touching metal surfaces prior to removing or servicing electronic equipment in this game. Avoid working on carpeted surfaces.



CAUTION: Electrical Shock Hazard.
Do not perform maintenance or repair of this equipment with power ON. Unplug the unit from the wall outlet or shut off power at the power

Shut off power to the game at the power strip located in the rear 'target' cabinet.

1. Remove the two wire clips from the solenoid.
2. Remove the hex nut holding the solenoid to the quick release valve.



3. Install the new solenoid and re-attach the wires. It doesn't matter which wire is attached to which terminal.

Turn on the power and test the unit.

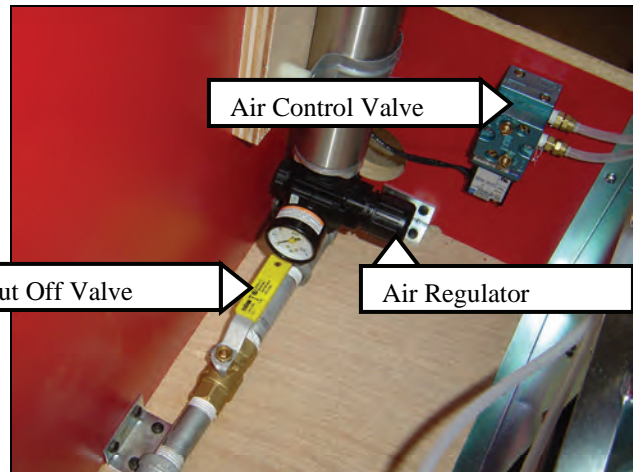

1. Shut OFF air pressure at the air shut-off valve or the air regulator. Release system pressure by firing the guns.
2. Disconnect the three air lines in to and out of the control valve.
3. Disconnect the wiring connector from the solenoid. Remove the mounting screws and remove from the game.
4. Install the new plug, re-attached the wire connector from the solenoid and re-attached the air lines.
5. Return power and air pressure to the game and test by firing the gun several times to insure that the balls are being loaded properly into the lift tube.

Service and Repair Section

Ball Sorter Gear Motor

The ball sorter gear motor assembly, in the middle cabinet, oscillates the paddles for the ball return chutes to keep the balls from becoming jammed in the chutes. Replace as follows.

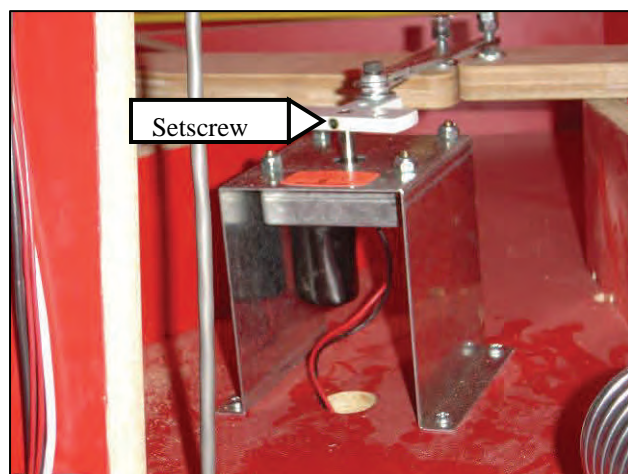

1. Remove the four bolts and washers from the two connector plates holding the front and middle cabinets together. Slide the front cabinet away from the middle cabinet slightly to gain access to the gear motor assembly.
2. Pull the two wires up out of the hole in the frame to expose the connector. Unplug the connector.
3. Remove the setscrew holding the connector cam assembly to the gearbox shaft and pull the cam off the shaft.
4. Remove the four locknuts that secure the gear motor assembly to the frame.
5. Install the new gear motor assembly with the four locknuts. The hole in the connector cam is flat on one side so the gearbox shaft may have to be rotated slightly to allow the cam to be installed. Secure with the setscrew.
6. Reconnect the wire connector.
7. Slide the two cabinets together, being careful not to pinch any wiring, and secure with the two connec-

Teeth Reset Gear Motor Replacement

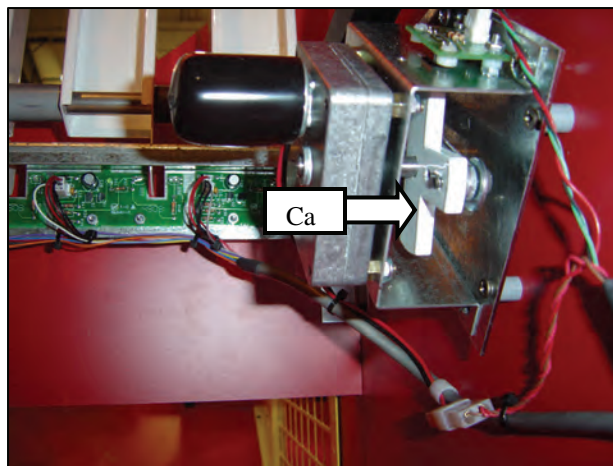

1. Open the access door in the rear cabinet and unplug the gear motor wiring at the connector.
2. Pull the tooth reset arm downward to manually rotate the connector cam to gain access to the setscrew. Loosen the setscrew and remove the cam from the shaft.
3. Remove the four locknuts mounting the motor/gearbox assembly in the mounting frame. Remove the gear motor assembly from the game.
4. Install the new gear motor and secure with the four locknuts.
5. Install the connector cam assembly onto the motor shaft and secure with the setscrew. The hole in the connector cam is flat on one side so the gearbox shaft may have to be rotated slightly to allow the cam to be installed. Secure with the setscrew.
6. Reconnect the wire connector.

Service and Repair Section - Circuit Boards

Target Score Sensors

The score sensors are mounted to a small circuit board and consist of an emitter and a detector on opposite sides of the target flag. To replace the sensor board.

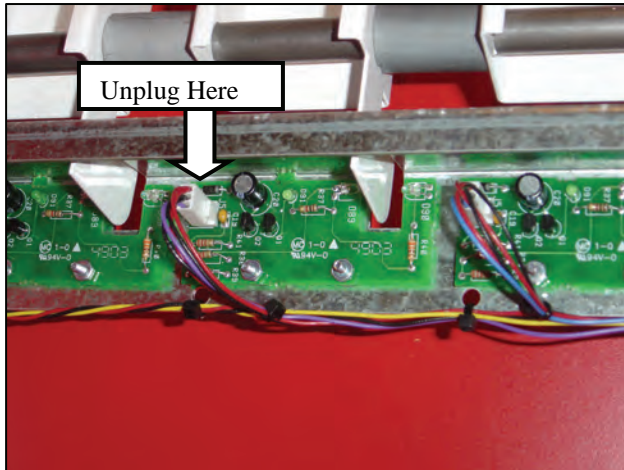

1. Open the access door of the rear cabinet and unplug the sensor wiring at the connectors on the sensor circuit board.
2. Unbolt the sensor boards.
3. Replace the sensor boards and reconnect the wire cables.
4. Test the sensors by moving the tooth so the tooth flag no longer blocks the sensors and scores a hit.

Main Circuit Board

Replacing the main Gen 5 circuit board.

1. Carefully unplug all wiring connectors.
2. Remove the four Phillips head screws at the four corners of the board and remove the board from the mounting panel.
3. Before installing the new board, check to be sure that the dipswitches are set in the same position as the old board.

NOTE: If swapping the circuit board with a spare Gen 5 board for testing purposes, be sure to also swap out the software chip. Use extreme care to prevent static electricity and to prevent bending socket pins.

4. Install the board and reconnect the wiring connectors and the white display cable.
5. Re-test the game.

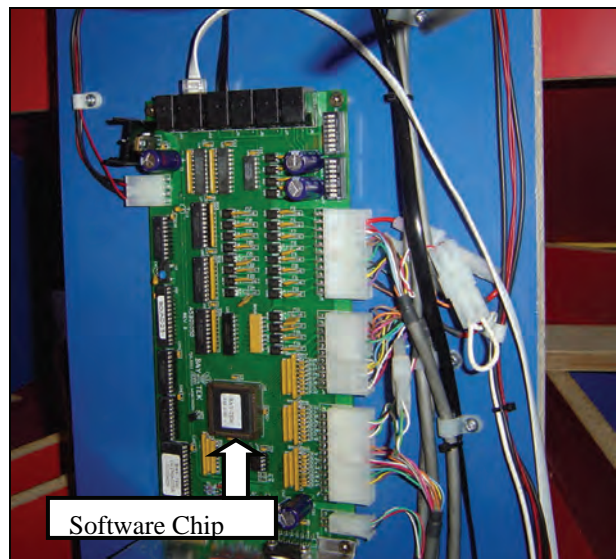

Electrical Drawing Section

Important

Power must be OFF to the game before removing any cable from the main board. Turn OFF the power strip inside the game.

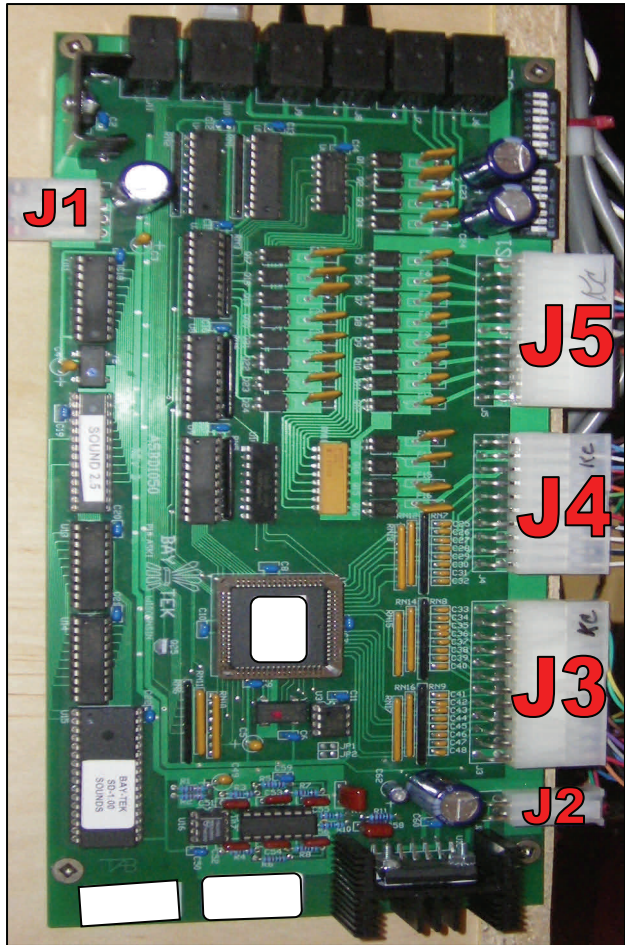
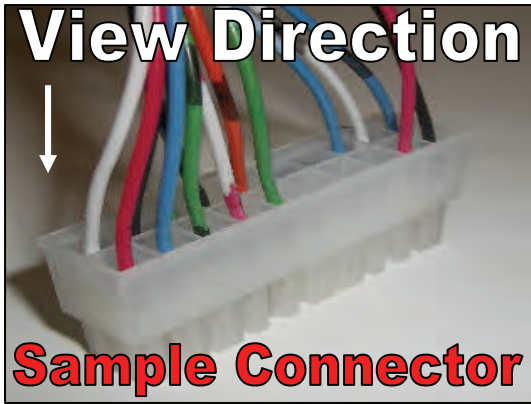

12. Volt Jumper Cable (J1)

BLK 12V Input	RED 12V Ground	BLK 12V Ground	RED 12v Input
-------------------------	-----------------------------	-----------------------------	-------------------------

Volume Cable (J2) Connector

RED Left Audio Output	GRN Right Audio Output
BLK Left Audio Ground	WHT Right Audio Ground

(J3) Connector

WHT L. Side Trigger Ground	GRN R. Side Trigger Ground
RED L. Side Trigger Input	BLK R. Side Trigger Input
WHT R. Side Low Ticket Signal	GRN L. Side Low Ticket Signal
TAN Unused	ORG Unused
GRY Unused	PNK Unused
RED Tooth #1 Input	WHT Tooth #2 Input
BLU Tooth #3 Input	BRW Tooth #4 Input
GRN Tooth #5 Input	BLK Tooth #6 Input
YEL R. Side Tooth Reset Motor Sensor Input	PUR L. Side Tooth Reset Motor Sensor Input

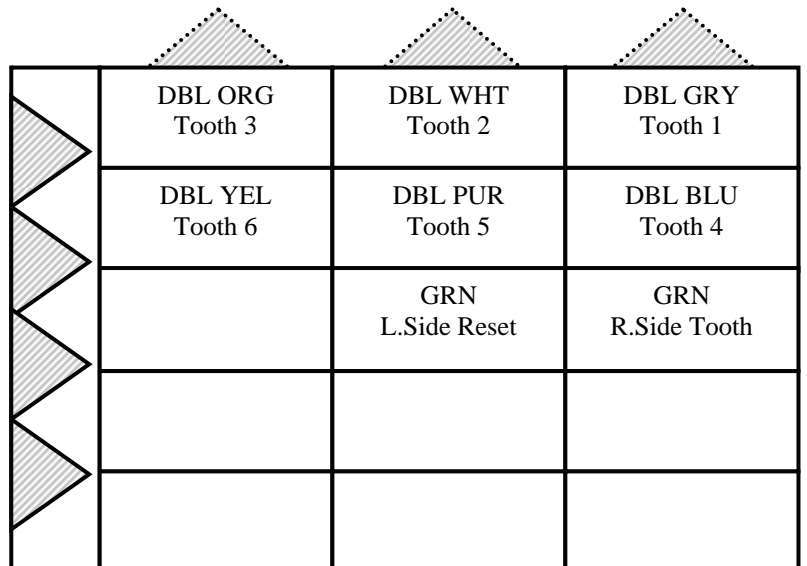
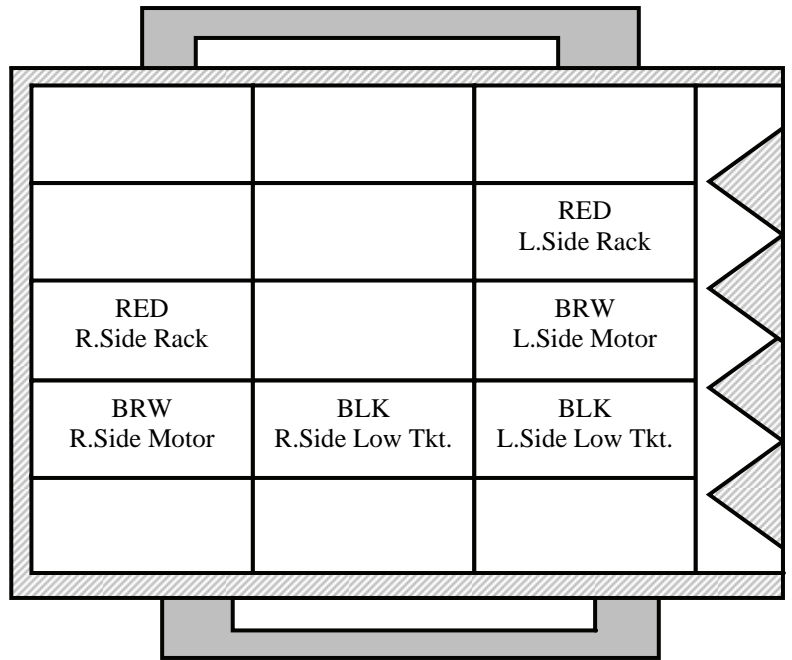
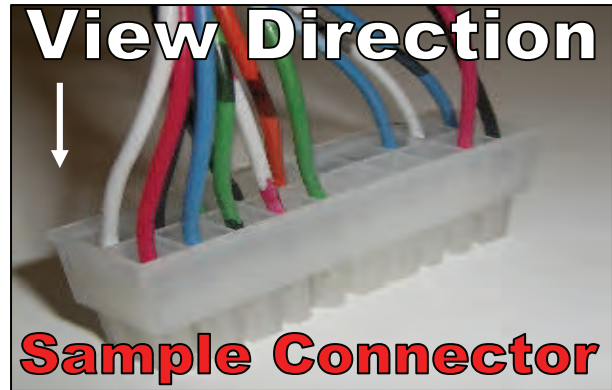

The cables and connectors used in the ramp “middle” section are universal therefore the number and color of wires does not matter. Match size of connector only. Below is a diagram showing the Inputs to that cable from the target cabinet.

Jumper Cable (J4) Connector

BRW GameCounter Signal	
PNK Counter +12v ORG R.Side Coin Door +12v	
TAN Ticket Counter Signal	
	GRN L.Side Coin Door Ground
GRY L. Side Coin In	
GRY R. Side Coin In	GRN R.Side Coin Door Ground BLK L.Side Tkt.
DBL YEL's Low Ticket Grounds	BLU L.Side Tkt. Notch Signal
WHT L.Side Tkt. Enable	RED L.Side Tkt. +12v ORG L.Side Coin Door +12v
BLK R.Side Tkt. Ground	BLU R.Side Tkt. Notch Signal
WHT R.Side Tkt. Enable	RED R.Side Tkt. +12v

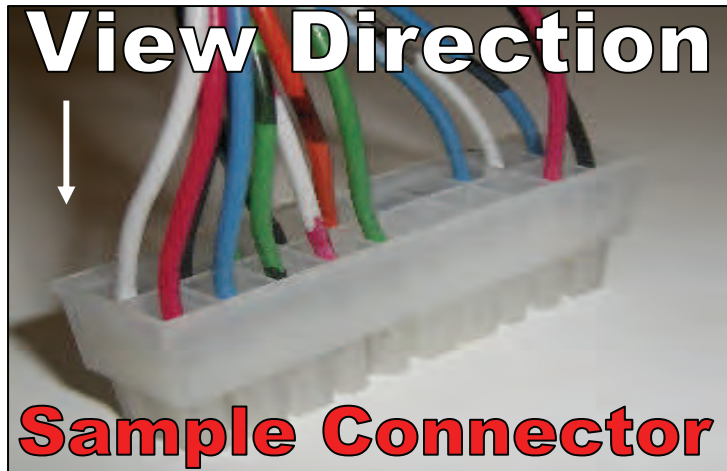

Jumper Cable (J5) Connector

RED Unused	ORG L.Side Tooth Reset Motor Output (inline fuse)
WHT Unused	GRY R.Side Tooth Reset Motor Output (inline fuse)
BLU L.Side Low Tkt. Light Output	PNK Unused
BRW R.Side Low Tkt. Output	TAN Unused
GRN Unused	BLK R.Side Lift Solenoid Output
BLK L.Side Teeth Sensor Enable	GRN R.Side Fire Solenoid Output
YEL R.Side Teeth Sensor Enable	BLK L.Side Lift Solenoid Output
PUR Unused	BRW L.Side Fire Solenoid Output

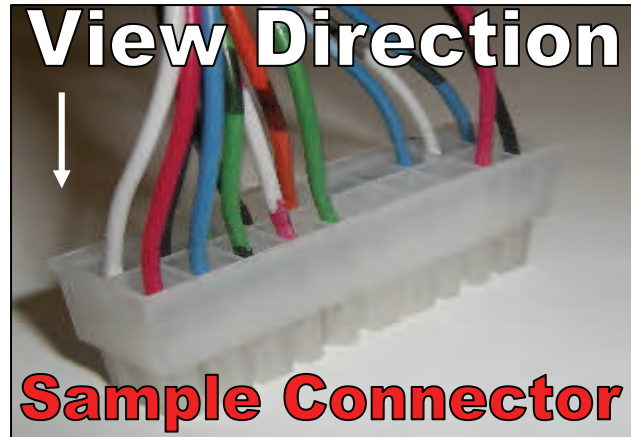

Gen 5 Main Board Schematics

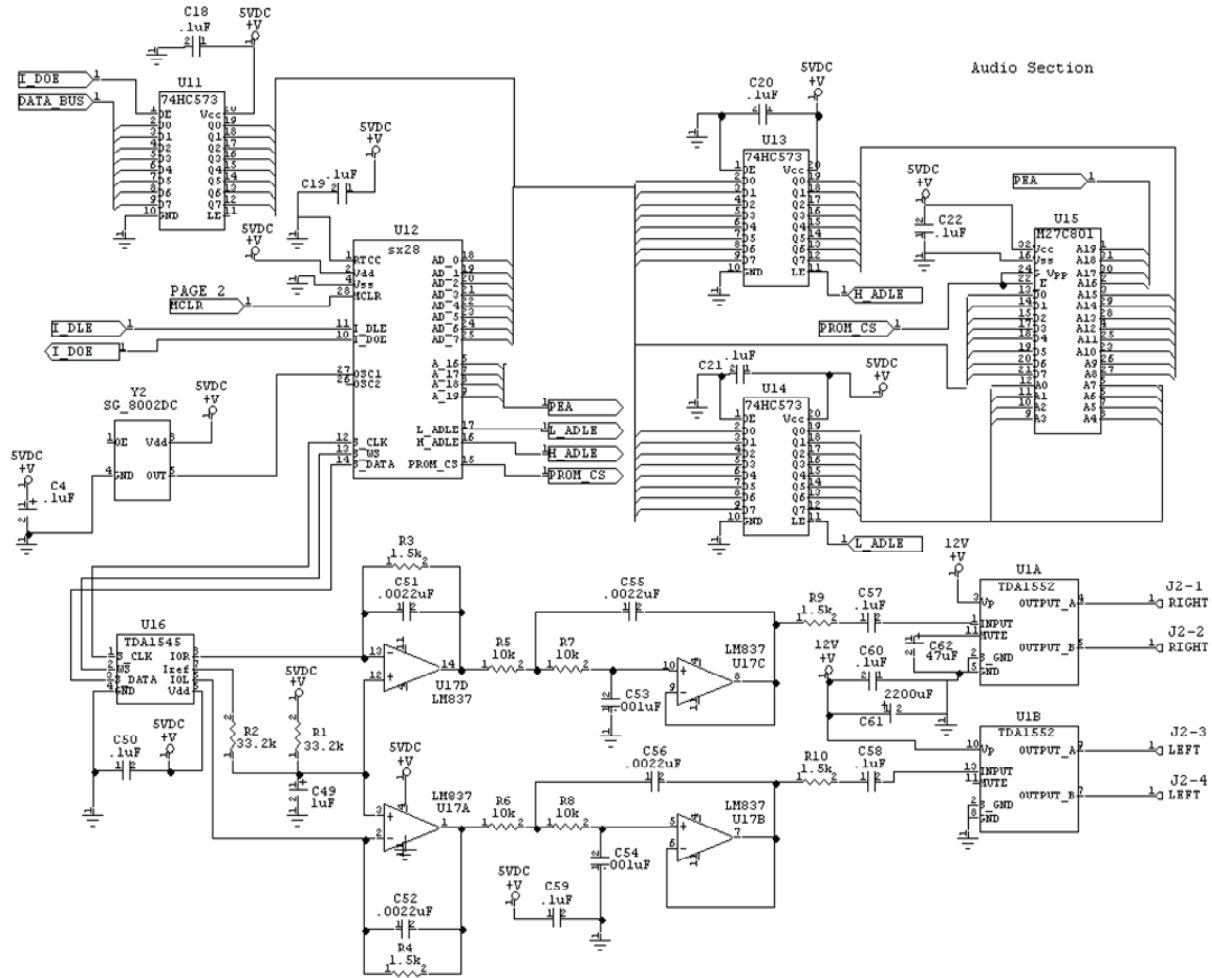

Communications - Serial EEprom

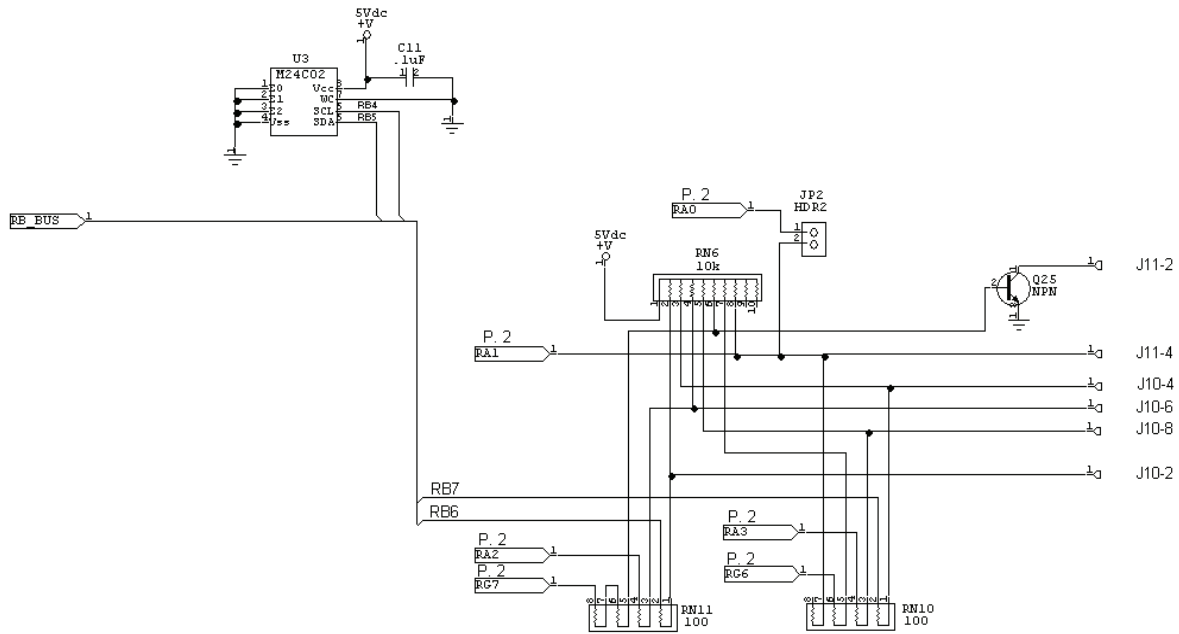

Input Section A - Con. Switches

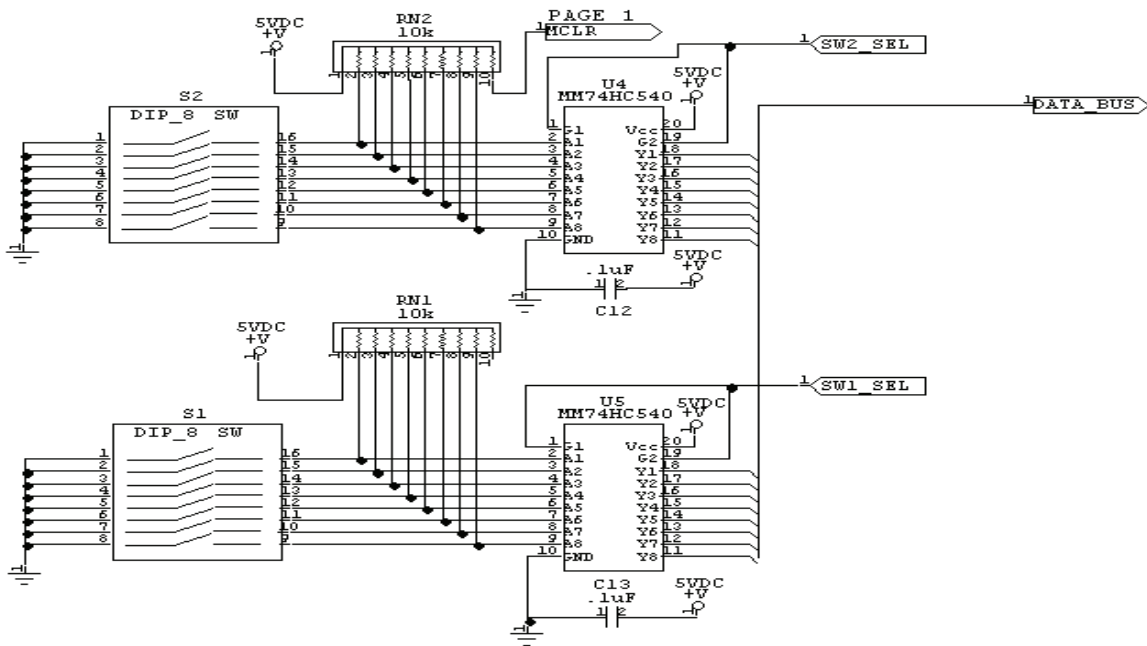

Input Section B - Inputs RE, RC

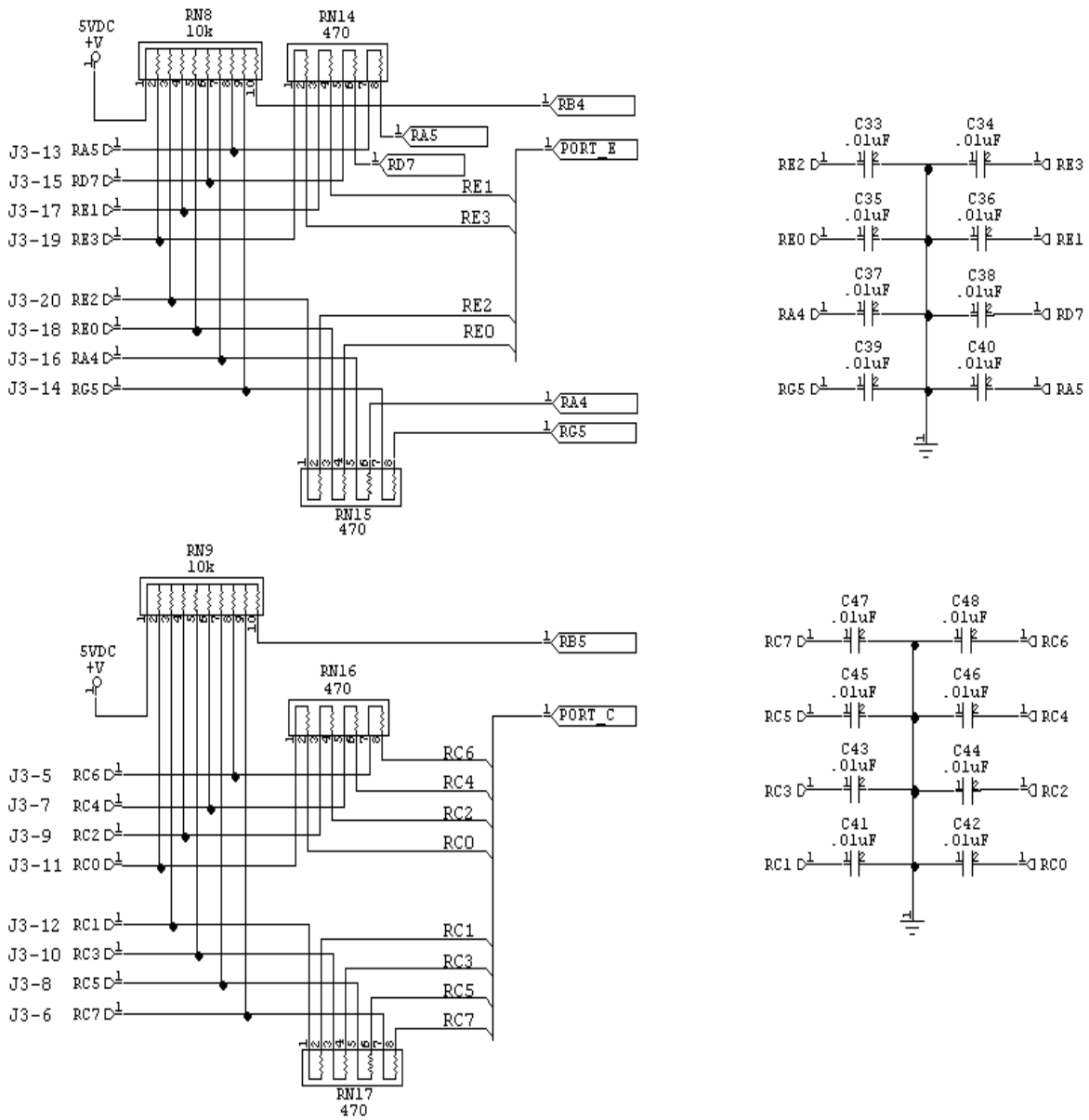

Output Section - Chase lights Q13-Q16

Output Section A
 - Chase Lights
 - Q13-16

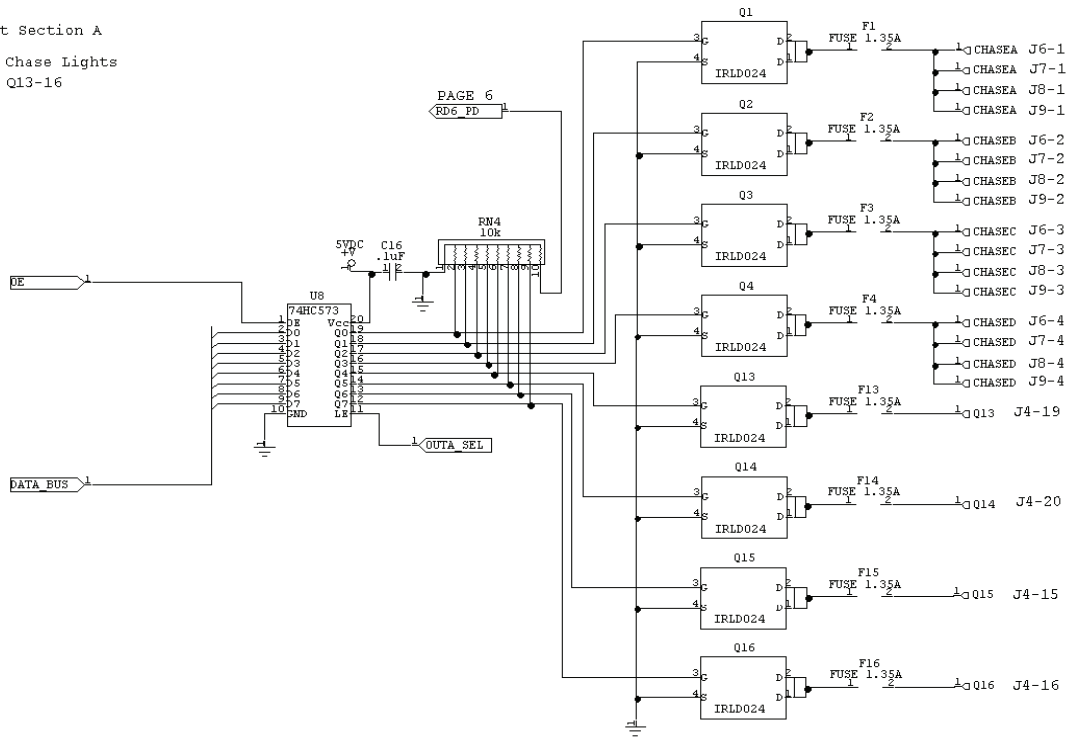

Output Section B Q17-Q24

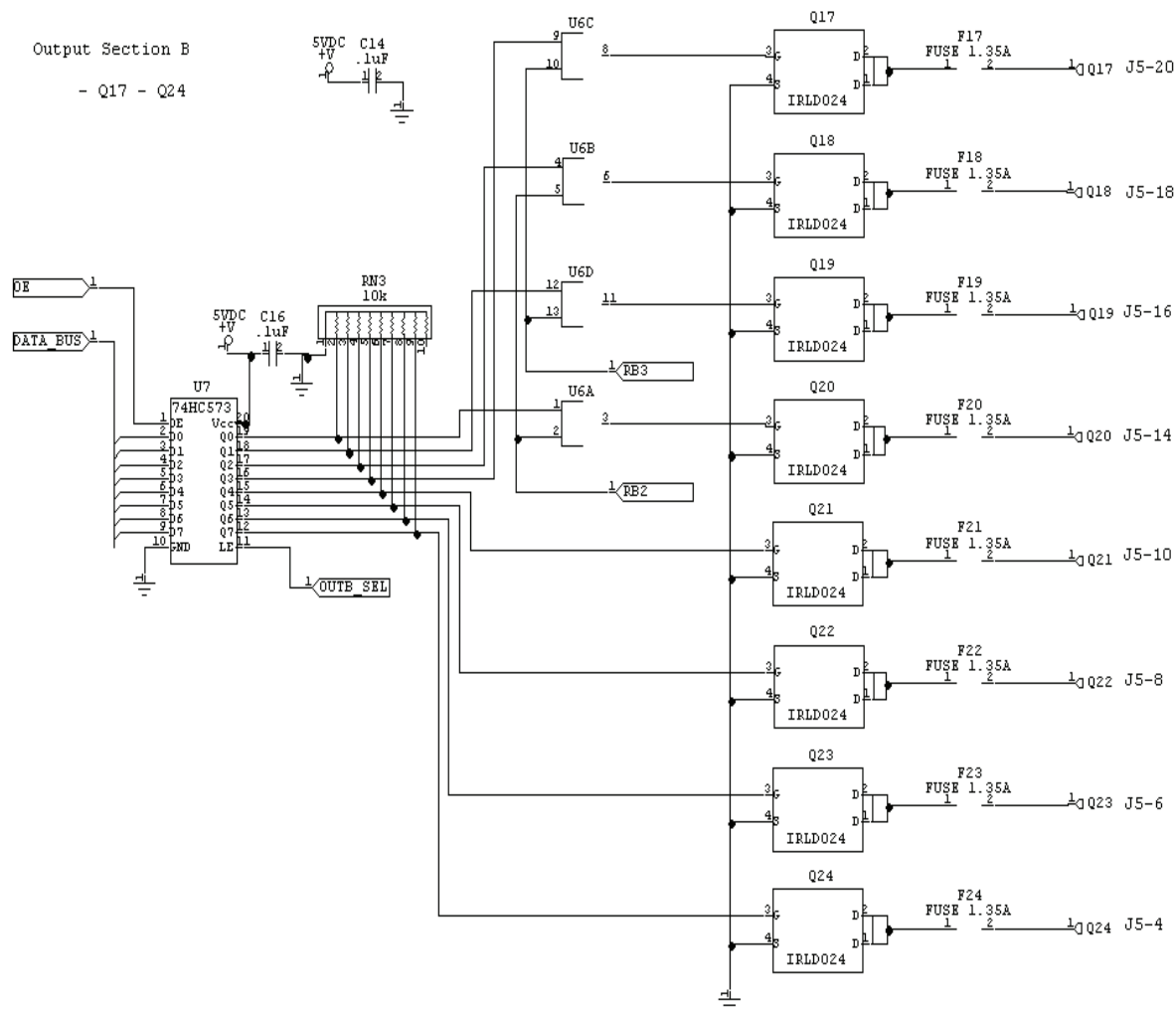

Output Section C Q5-Q12

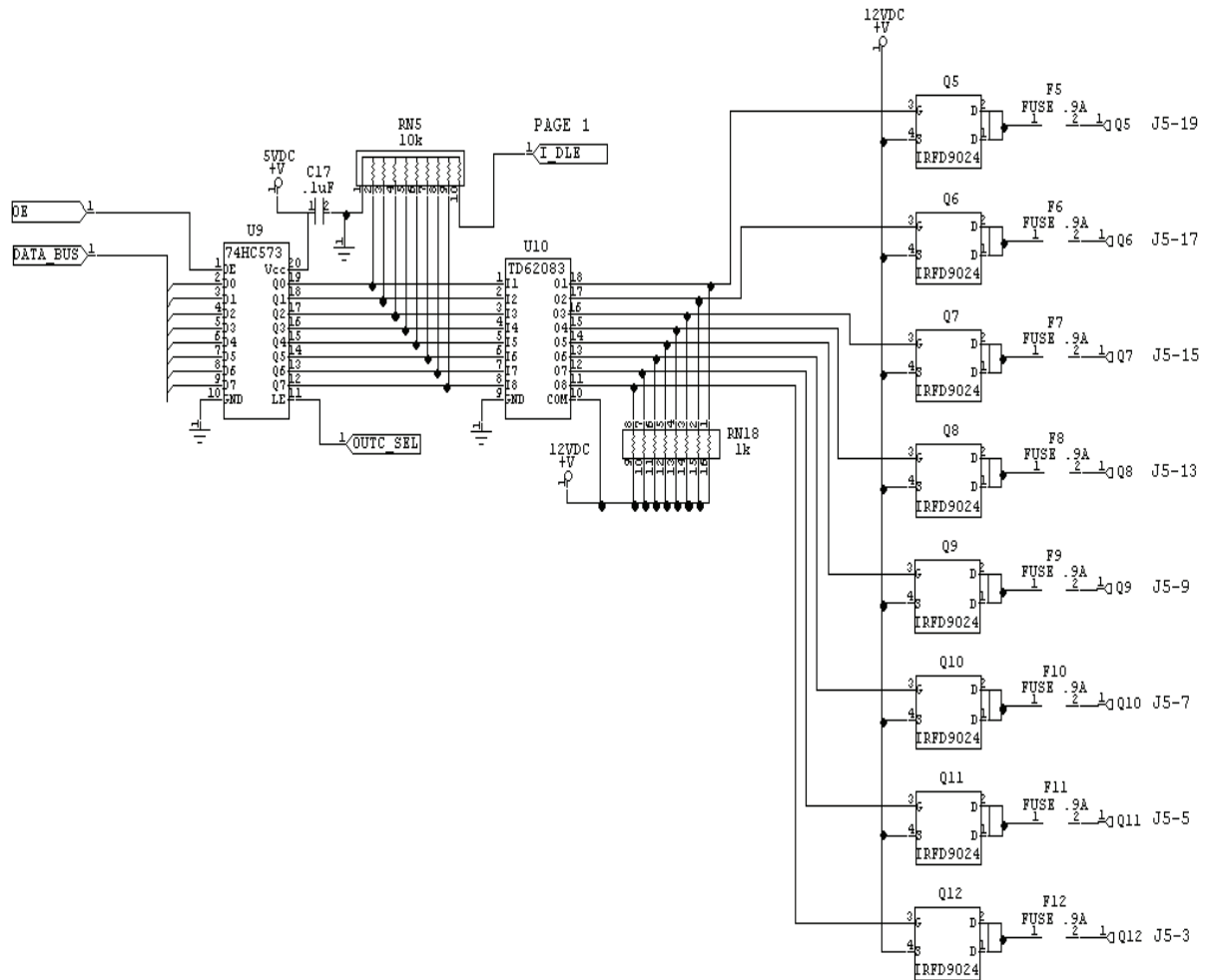

Power Section

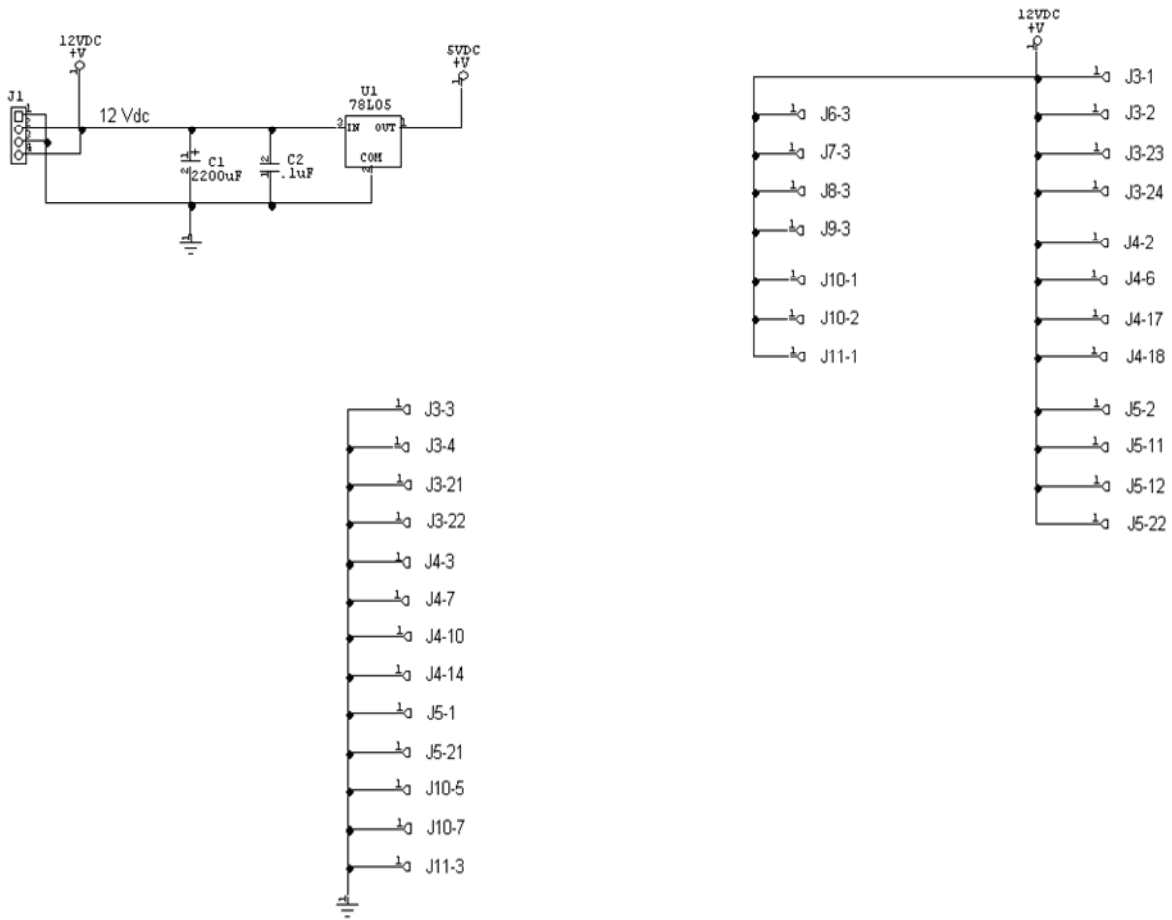

Processor Section - Input RD

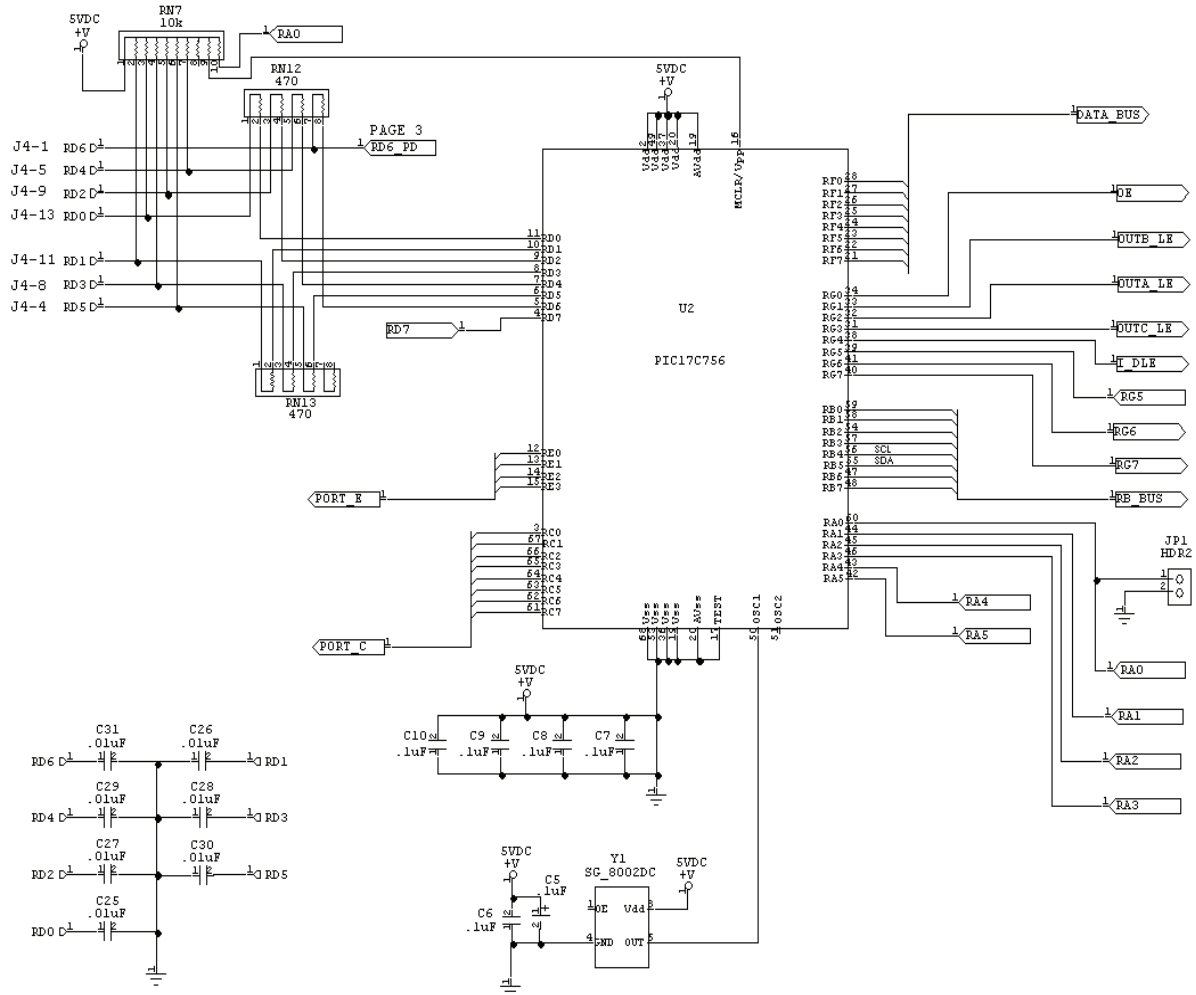

MAINTENANCE LOG

If you need to make repairs or order replacement parts it is a good idea to keep a log.
 Below is a chart you can use to track repairs and maintenance.

DATE	MAINTENANCE PERFORMED	PARTS ORDERED	INITIALS

TECHNICAL SUPPORT™

Excellent customer service is very important to Bay Tek Games! We know that keeping your games in great operating condition is important to your business. When you need us, we are here to help. You can call us for free technical assistance, and you can count on us to have parts on-hand to support your game. When you do need us, it's important that you know what to expect. We offer options that fit your needs.

Electronics / Circuit Boards - Repair Options

Repair & Return – If you have Circuit Board issues with your Bay Tek game, you can send the board to us and we'll repair it right away. Most items sent to us are repaired and returned to you within two days. This option is your best value as we offer this fast turn-around service at the most reasonable price.

Advance Replacement – If you have Circuit Board issues with your Bay Tek game, but you don't have time to send in your board in for repair, give us a call and ask for an Advance Replacement. We'll send you a replacement board that same day (pending availability). When you get your new board, just repackage the defective board in the same box and send it back to us. We make it easy by including a UPS Return Shipping label for you to put on the box (not available for international shipments). This is your best option when you need to get your game up and running as quickly as possible!

Spare Parts – Take matters into your own hands and purchase new spare Circuit Boards for your Bay Tek games. Many of our games share the same main-board electronics. This means you can buy one set of spare electronics to support many of your Bay Tek games. Spare boards allow you to get your game up and running the quickest and provide you a valuable troubleshooting option. Call our technicians to get recommendations for what you should keep on hand for spare parts!

Technical Support:

“You” are the best tool for troubleshooting! Your abilities to understand the game and your skills to repair the game are invaluable to us! If you need help, you know you can call us. It's not easy to diagnose a game remotely by phone, but our technicians do a great job. They'll need your help to perform some troubleshooting steps and convey to them exactly what's happening with your game.

Returns, Credits, & Fees:

NOTICE! ALL ITEMS being sent to Bay Tek Games for repair or return, etc. require prior Return Authorization! Bay Tek Games will provide a Product Return Form with an authorizing Ticket Number for each item to be returned. Please be certain to include this document with all shipments!

Late Fees and Non-Return Fees - Advance Replacement and Warranty Replacement items require the defective items to be returned by Bay Tek games promptly to avoid Late Fees. We would expect items to be returned within 10 working days. Late fees are invoiced monthly. Late fees are non-refundable under any circumstance! Any item not returned within 90 days will be invoiced in full as a replacement part!

Bench Fees - Bench fees will apply for each electronic item returned to Bay Tek Games (this includes unused Advance Replacement items). This charge covers our cost to inspect, evaluate and retest each item. Please note that returned items that do not pass our tests will be charged accordingly as replacement items or advance replacements.

Restocking Fees - Unused items returned for credit will be credited minus a restocking fee. Items must be returned within 30 days of purchase in order to qualify for any credit amount. No shipping charges will be credited.

WARRANTY

Bay Tek Games warrants to the original purchaser that all game components will be free of defects in workmanship and materials for a period of 6 months from the date of purchase.

Hint: Register your new game for an extra 3 months on your warranty (Find registration card in the cashbox)

Bay Tek Games will, without charge, repair or replace at it's option defective component parts upon notification to the parts/service department.

Warranty replacement part(s) will be shipped immediately, via ground service, along with a Product Return Form for the return of defective part(s).

Defective part(s) must be shipped back to Bay Tek Games unless otherwise instructed. Items not returned to Bay Tek Games will be invoiced as replacement parts.

This warranty does not apply in the event of any misuse or abuse to the product, or as a result of any unauthorized repairs or alterations. The warranty does not apply if any serial number decal is altered, defaced, or removed from it's original position.

ATTENTION



In order to maintain the safety & other compliance certifications of the game, **ONLY** approved parts may be used. For approved parts, refer to the parts list in this manual.



Should you need your game serviced, determine the serial number from the decal placed on the front of this manual, or locate it on the back of the game. Then contact our Service Department at: 920.822.3951 or e-mail: service@baytekgames.com

NON-WARRANTY

Should you need your game serviced, determine the serial number on the front page of this manual, or by locating the decal on the back of the game cabinet, and contact our Service Department at: 920.822.3951 or service@baytekgames.com

Options and estimated charges will be provided to you for your approval.

Please remember that any items being sent to Bay Tek Games must include prior return authorization from our Parts & Service Department. This approval will include a Product Return Form which is required to be included with any incoming shipments. Repaired part(s) will be shipped back using the same method in which they were received. Repairs are warranted for 30 days from the date of return shipment.



passion in ★ fun out

IF WE'RE NOT HAVING FUN...SOMETHING'S WRONG."

- LARRY TREANKLER, CEO

Cannonball Blast

**COPYRIGHT NOTICE:
CANNONBALL BLAST™
IS A TRADEMARK AND COPYRIGHT©
SOLELY OWNED BY BAY TEK GAMES, INC**



web: baytekgames.com

phn: (920) 822 3951

fax: (920) 822 8936

hqm: Pulaski Industrial Park, 1077 East Glenbrook Drive, Pulaski WI 54162, U.S.A.