

**NASA
Reference
Publication
1311**

June 1996

**Computer Program for Calculation of
Complex Chemical Equilibrium
Compositions and Applications**

II. Users Manual and Program Description

Bonnie J. McBride and Sanford Gordon



National Aeronautics and
Space Administration
Lewis Research Center
Cleveland, Ohio 44135

**NASA
Reference
Publication
1311**

1996

**Computer Program for Calculation of
Complex Chemical Equilibrium
Compositions and Applications**

II. Users Manual and Program Description

Bonnie J. McBride
Lewis Research Center
Cleveland, Ohio

Sanford Gordon
Sanford Gordon and Associates
Cleveland, Ohio



National Aeronautics and
Space Administration

Office of Management

Scientific and Technical
Information Program

Contents

Chapter	
1. Introduction	1
2. Description of Program Input	3
2.1 General Rules	3
2.1.1 File Names.....	3
2.1.2 Datasets	4
2.1.3 Keywords	4
2.1.4 Mandatory Keywords	4
2.1.5 Optional Keywords.....	4
2.1.6 Types of Variables.....	5
2.1.7 Delimiters.....	6
2.2 Specific Free-form Variables for CEA Datasets.....	6
2.3 Dataset reac	6
2.3.1 Identification and Order	7
2.3.2 Names of Reactants.....	7
2.3.3 Relative Amount of Reactant.....	8
2.3.4 Reactant Temperature.....	8
2.3.5 Assigned Enthalpy or Internal Energy.....	9
2.3.6 Exploded Chemical Formula	9
2.3.7 Density of Reactant.....	10
2.3.8 Option To Use <i>thermo.lib</i>	10
2.4 Dataset prob	12
2.4.1 Case Identification.....	12
2.4.2 Problem Type.....	12
2.4.3 Fuel-Oxidant Mixture Values.....	13
2.4.4 Option To Include Ionized Species.....	13
2.4.5 Options for Rocket Problems.....	14
2.4.6 Options for Shock Problems.....	14
2.4.7 Temperature Schedule.....	15
2.4.8 Pressure Schedule.....	15
2.4.9 Specific Volume Schedule.....	16
2.4.10 Density Schedule.....	16
2.4.11 Assigned Enthalpy.....	16
2.4.12 Assigned Internal Energy	17
2.4.13 Assigned Entropy.....	17
2.4.14 Assigned Values for Shock Problems.....	17
2.4.15 Assigned Values for Rocket Problems.....	18
2.5 Dataset outp	20
2.5.1 cal.....	20
2.5.2 deb (or dbg).....	20
2.5.3 massf	20
2.5.4 plot	20
2.5.5 short.....	23
2.5.6 trac	23
2.5.7 tran	23
2.5.8 Examples of outp Datasets	23

2.6 Options Involving Species To Be Considered.....	23
2.6.1 Dataset only	24
2.6.2 Dataset omit	24
2.6.3 Dataset inse	24
2.7 Dataset end	24
2.8 Thermodynamic and Thermal Transport Property Data Bases.....	25
3. Description of Program Output	27
3.1 Input Data	27
3.2 Intermediate Input Data.....	27
3.2.1 True/False Options.....	28
3.2.2 Schedules of Assigned Values.....	28
3.2.3 Reactant Information.....	28
3.2.4 Species Being Considered.....	29
3.2.5 Species With Thermal Transport Properties.....	29
3.2.6 Enthalpies and Relative Atoms Per Kilogram.....	29
3.3 Tables of Results.....	29
3.3.1 Thermodynamic Mixture Properties.....	30
3.3.2 Thermal Transport Mixture Properties.....	30
3.3.3 Rocket Performance Parameters.....	30
3.3.4 Shock Parameters	30
3.3.5 Chapman-Jouguet Detonation Parameters.....	30
3.4 Intermediate Output Data.....	30
3.4.1 Number of Iterations	31
3.4.2 Iteration Matrices and Compositions.....	31
3.4.3 Condensed-Phases Test.....	32
3.4.4 Derivative Matrices	32
4. Modular Form and Modification of Program	33
4.1 Main Program and BLOCKDATA Module.....	33
4.2 General Input Module	36
4.3 Data-Preprocessing Module.....	36
4.4 Applications Module	36
4.5 Additional Input-Processing Module	37
4.6 Equilibrium Module.....	37
4.7 Transport Properties Module	37
4.8 Output Module.....	38
4.9 Modifications	38
4.9.1 PARAMETER Statements.....	39
4.9.2 Changing Number of Possible Reaction Products.....	40
4.9.3 Eliminating an Application.....	40
4.9.4 Adding an Application	40
5. Routines	41
5.1 Main Program	41
5.2 BLOCKDATA.....	42
5.3 Subroutine CPHS.....	42
5.3.1 General.....	42
5.3.2 Entry ALLCON.....	42
5.4 Subroutine DETON.....	43
5.5 Subroutine EFMT.....	43
5.6 Subroutine EQLBRM.....	43
5.7 Subroutine FROZEN	43
5.8 Subroutine GAUSS.....	44
5.9 Subroutine HCALC	44
5.10 Subroutine INFREE.....	45
5.11 Subroutine INPUT.....	45
5.12 Subroutine MATRIX.....	46

5.13 Subroutine NEWOF.....	47
5.14 Subroutine OUT1.....	47
5.14.1 Entry OUT2.....	47
5.14.2 Entry OUT3.....	48
5.14.3 Entry OUT4.....	48
5.15 Subroutine REACT.....	48
5.16 Subroutine RKTOUT.....	49
5.17 Subroutine ROCKET.....	49
5.18 Subroutine SEARCH and Entry READTR.....	50
5.19 Subroutine SETEN.....	50
5.20 Subroutine SHCK.....	51
5.21 Subroutine THERMP.....	51
5.22 Subroutine TRANIN.....	51
5.23 Subroutine TRANP.....	52
5.24 Subroutine UTHERM.....	53
5.25 Subroutine UTRAN.....	54
5.26 Subroutine VARFMT.....	54
6. Error Messages.....	55
6.1 DETON Message.....	55
6.2 EQLBRM Messages.....	55
6.3 FROZEN Message.....	57
6.4 HCALC Messages.....	58
6.5 INFREE Messages.....	58
6.6 INPUT Messages.....	58
6.7 REACT Messages.....	60
6.8 ROCKET Messages.....	61
6.9 SEARCH Messages.....	63
6.10 SHCK Messages.....	63
6.11 TRANIN Message.....	64
6.12 UTHERM Message.....	64
6.13 UTRAN Message.....	64
7. Example Problems.....	65
7.1 Examples 1 and 2.....	67
7.1.1 Example 1.....	67
7.1.2 Example 2.....	67
7.2 Examples 3 and 4.....	68
7.2.1 Example 3.....	68
7.2.2 Example 4.....	68
7.3 Example 5.....	68
7.4 Example 6.....	69
7.5 Example 7.....	69
7.6 Examples 8, 9, and 10.....	69
7.6.1 Example 8.....	70
7.6.2 Example 9.....	70
7.6.3 Example 10.....	70
7.7 Example 11.....	70
7.8 Example 12.....	71
7.9 Example 13.....	71
7.10 Example 14.....	71
Appendixes	
A. Format for Thermodynamic Data.....	73
Table A.1.—General Format for Nine-Constant Functional Form.....	73
B. Names of Species in Thermodynamic Data File (<i>thermo.inp</i>).....	75
Table B.1.—Names of Gas-Phase Products in <i>thermo.inp</i>	76
Table B.2.—Names of Condensed-Phase Products in <i>thermo.inp</i>	80

Table B.3.—Names of Reactants in <i>thermo.inp</i>	82
C. Thermodynamic and Density Data for Reactants	83
Table C.1.—Thermodynamic and Density Data for Reactants.....	84
Table C.2.—Reactant Thermodynamic Data in <i>thermo.inp</i> Format.....	86
D. References for Reactant Data in Table C.1.....	91
Table D.1.—References for Reactant Data in Table C.1	92
E. Format and List of Species with Thermal Transport Property Data.....	95
Table E.1.—Format for Thermal Transport Property Data.....	96
Table E.2.—Viscosity and Thermal Conductivity Coefficients in <i>thermo.inp</i>	97
F. COMMON Variables Used in Equilibrium Module.....	107
Table F.1.—COMMON Variables That Must Be Initialized Before Entering Equilibrium Module.....	108
Table F.2.—COMMON Variables Calculated by Equilibrium Module	110
G. Example Problems.....	111
References.....	177

Chapter 1

Introduction

This is the second part of a two-part report describing the NASA Lewis Research Center's computer program CEA (Chemical Equilibrium with Applications). The program is used to obtain chemical equilibrium compositions of complex mixtures with applications to several types of problems. Part I (Gordon and McBride, 1994) states the various assumptions on which the calculations are based and analyzes the appropriate equations and mathematical methods for their solution. The equations describe the conditions for chemical equilibrium and for applications such as rocket performance, shocks, and detonations. The thermodynamic and thermal transport property data bases are also briefly described.

This second part is a users manual. Chapter 2 presents details for preparing input files. The format for input differs considerably from that used in earlier versions of the CEA program (Gordon and McBride, 1976; McBride et al., 1994). The output tables for various types of problems and options are described in chapter 3. Chapter 4 presents the overall modular organization of the program with information on how to make modifications. Chapter 5 presents information on the function of each subroutine. Error messages and their significance are discussed in chapter 6. Chapter 7 gives a number of examples that illustrate various types of problems handled by CEA and cover many of the options available in both input and output.

Seven appendixes are also included. Appendixes A to D give information on the thermodynamic data used in CEA. Appendix A gives the format for the thermodynamic data file *thermo.inp*, and appendix B lists species names contained therein. This file contains data in the form of least-squares coefficients for reactants as well as for products. Some of the reactant data are itemized in appendix C; references for these data appear in appendix D. Appendix E presents the format for thermal transport property data. Appendix F contains some information on common variables used in or generated by the equilibrium module discussed in section 4.6. Finally, appendix G lists the tabular output for the example problems discussed in chapter 7. The mathematical symbols used in this report are defined in Gordon and McBride (1994).

The CEA program consists of the following five files: the source program (*cea.for*), thermodynamic data (*thermo.inp*), thermal transport properties (*trans.inp*), sample problems (*cea.inp*), and *readme.txt*. After the *cea.for* file has been compiled, the unprocessed thermodynamic and transport property data should be processed once (see section 2.8). These processed data (in binary form) are stored in *thermo.lib* and *trans.lib*, where they remain available for future use in running problems. Additional information on the *thermo.inp* and *trans.inp* files is given in section 2.8 and appendixes A to E.

The CEA program was written in ANSI standard FORTRAN 77. CEA should work on any system with sufficient storage. There are approximately 6300 lines in the source code, which uses 225 kilobytes of memory. The compiled program takes 975 kilobytes. Input data bases *thermo.inp* and *trans.inp* use approximately 850 and 32 kilobytes, respectively; the binary forms *thermo.lib* and *trans.lib* take approximately 425 and 20 kilobytes, respectively. These storage requirements for the program and the data files may be easily adjusted as discussed in the following chapters.

Chapter 2

Description of Program Input

The CEA program requires two types of input. One type consists of files of thermodynamic data (*thermo.inp*) and thermal transport property data (*trans.inp*), which are common to all problems. These two files accompany the CEA program. The second type is input for the specific problem to be solved and is prepared by the user. The problem input consists of seven categories of input datasets. These seven datasets are in a general free-form format that was not used in previous versions of the CEA program (e.g., Gordon and McBride, 1976, or McBride et al., 1994). Most of the material in this chapter describes the general rules (see section 2.1) as well as details for preparing input datasets (see sections 2.2 to 2.7).

Thermo.inp and *trans.inp* are not in the free-form format because the data were generated by other programs (e.g., McBride and Gordon, 1992). Section 2.8 gives some information on processing these files before running specific problems. Because these files contain unprocessed thermodynamic and thermal transport data, we recommend that you first preprocess these files with the CEA program, which will store the data in binary form in two libraries called *thermo.lib* and *trans.lib* (see section 2.8). The CEA program will then use these processed libraries for all future runs. The prefixes *thermo* and *trans* in the input data files could have been any other names; they were selected to be consistent with the prefixes automatically assigned by CEA to the library files.

2.1 General Rules

The general rules for preparing input pertain to file names, keywords, types of variables, and delimiters.

2.1.1 File Names

All input files must be named with an arbitrary prefix and the suffix *.inp* (i.e., (*input prefix*).*inp*). Output files for listing are automatically given the same prefix as the input file and the suffix *.out*. As an option, additional output files of columns of numbers can be obtained for plotting purposes. These files will also be given the same prefix and the suffix *.plt*.

2.1.2 Datasets

All useful program input is divided into sets of records called datasets. The first record of each dataset starts with a keyword. Records that start with the symbols “#” and “!” or totally blank records will be considered comments (i.e., they will be printed but not used).

2.1.3 Keywords

The keywords must be

1. The first nonblank characters in a record
2. All lower-case letters
3. A word that starts with one of the following sets of three or four letters: **prob**, **reac**, **only**, **omit**, **inse**, **outp**, **end**, **ther**, and **tran**. Additional characters may be used in the keywords but will be ignored by the program (e.g., **problem** is equivalent to **prob**). The last two keywords must begin records that precede formatted data bases. The first seven keywords precede data in CEA's free form.

2.1.4 Mandatory Keywords

There are three mandatory keywords for every problem. These words, with a brief description of any associated data, are as follows:

Keyword	Data
prob	Problem type and associated input (see section 2.4)
reac	Reactant names and associated input (see section 2.3)
end	No data. Keyword signals the end of the problem.

2.1.5 Optional Keywords

There are four optional keywords for every problem. Three are always followed by product species names typed exactly as used in the coefficients data base (see appendix B). The keywords are as follows:

Keyword	Data
only	Set of names of species that are the only ones to be considered in the problem
omit	Set of names of species that are to be omitted as possible products
inse	Set of names of condensed species to be tried (inserted) with gaseous species for initial equilibrium iterations
outp	Nonstandard options for output

2.1.6 Types of Variables

There are three types of variables, each limited to 15 characters. Additional characters will be ignored. The variables are as follows:

Type	Characteristics
Literal	<p>First character is alphabetic.</p> <p>All initial characters are lower case, with three exceptions which follow:</p> <p>Chemical element symbols start with upper-case letters; the second letter may be either upper or lower case.</p> <p>Reactant names may start with either upper- or lower-case letters.</p> <p>Case (problem) identification may be either upper- or lower-case letters or numbers (see section 2.4.1).</p> <p>Sometimes the program checks for embedded lower-case character strings as well as initial character strings. For example, the symbol for pressure is p and the embedded string indicates the units.</p> <p>Examples:</p> <p style="padding-left: 40px;">p, bars</p> <p style="padding-left: 40px;">p(bars)</p> <p style="padding-left: 40px;">pressure: bars</p>
Numeric	Any legitimate integer, decimal, or floating-point number
Species names	The set of characters used with the coefficient data bases to identify the species. These names never have embedded blanks, tabs, or equal signs because these characters are delimiters.

2.1.7 Delimiters

There are several delimiters for separating variables. These delimiters, which follow the variable, are as follows:

Delimiter	Variables separated
One or more blanks or tabs	Any variables (literals, numerics, or species names).
Equal sign	Literals (may be used in combination with blanks and tabs)
Comma	Numerics (may be used in combination with blanks and tabs)

Example:

```
problem tp p,atm=1, 2,3, t= 3000 2000 1000,500
```

(Note that `p, atm` is one literal variable; commas separate only numeric variables.)

2.2 Specific Free-Form Variables for CEA Datasets

As discussed in the general rules, CEA input consists of datasets and comments. Comments start with either “#” or “!”. Datasets start with keywords. Datasets in the free-form format that are headed by the keywords **reac**, **prob**, **end**, **only**, **omit**, **inse**, and **outp** are discussed here. (Note that when defining keywords and literals in the following sections, only the abbreviated character strings checked by the program are listed.)

Free-form datasets have the following order:

1. If the thermodynamic and transport data bases have not been processed, any free-form input must follow these data.
2. Datasets may be in any order, except for the **end** dataset, which must be the last record for any problem.
3. Variables or species names within a dataset may be in any order, with one exception in the **reac** dataset (see section 2.3.1). Also, any numerics associated with a literal variable must follow the literal.

2.3 Dataset **reac**

The **reac** dataset includes names and parameters for the reactants. It replaces the fixed-format REACTANT records of previous versions of the CEA program (e.g., Gordon and McBride, 1976, or McBride et al., 1994). The details for preparing a **reac** dataset are given in the following subsections.

Chemical species (products as well as reactants) are identified in two forms in the CEA program. One form may be a name or a conventional formula of the species (without

subscripts), such as H₂O for water, CH₄ for methane, or Air for air. This form is discussed in section 2.3.2. The other form for identifying a species is referred to as the “exploded” form or formula and is discussed in section 2.3.6. Both forms are required in the CEA program and both forms are given in the thermodynamic data file, *thermo.lib*. The exploded formula may be specified directly in the **reac** dataset or obtained from *thermo.lib* if it contains the species. Some comparisons of these two ways are given in section 2.3.8.

Most types of problems require a value for the enthalpy (or internal energy) of the reactant mixture at some specified temperature. Energies are discussed in section 2.3.5; and temperatures, in section 2.3.4. As in the case for exploded formulas, enthalpies (or internal energies) may be specified in the **reac** dataset or optionally obtained from *thermo.lib*. Some comparisons of these two options for specifying energy are given in section 2.3.8.

2.3.1 Identification and Order

Each reactant and its parameters are identified by one of three sets of initial characters: **f u**, **o x**, and **n a**. Each of these literal variables must precede the reactant name. All associated parameters follow the reactant name in any order. This information will be printed in the final tables. Summarizing, the reactant identifiers are

Initial characters	Data
f u	Fuel name followed by associated data
o x	Oxidant name followed by associated data
n a	Name and data of reactant not identified as a fuel or oxidant. When name is used in any particular dataset, all reactants must use the name label.

Examples:

```
reac fuel Jet-A(L) ...
      oxid Air ...

reac name H2 ...   name O2 ...   name Ar ...
```

(Note that the ellipses represent additional input not shown here.)

2.3.2 Names of Reactants

Restrictions on names of reactants are as follows:

1. As many as 15 characters will be stored. The names must not contain any embedded blanks, tabs, or equal signs, since they are delimiters (see section 2.1.7). Upper-case letters are acceptable. The first character must not be a “+”, “-”, “.”, or number.
2. Section 2.3.8 presents some examples using the option for obtaining the exploded chemical formula and the enthalpy (or internal energy) from *thermo.lib*. When this option is used, the input name must match exactly the name used in *thermo.inp*. These names are given in appendix B. (Note that the list in appendix B is current as of the date of publication of this report but is often added to.) For example, Jet-A(L) and Air

used in an example in section 2.3.1 are exactly the names required to identify these species (including upper- and lower-case letters). By contrast, names such as jet-A(1) and air are incorrect.

2.3.3 Relative Amount of Reactant

Amounts of oxidants are given relative to total oxidant, and amounts of fuels are given relative to total fuel. If reactants are not specified as fuels or oxidants, the amounts of reactants are relative to total reactant. All values must follow a literal with one of the initial characters m or w defined here:

Initial character	Data
m	Amount given in moles. In a particular dataset, if any reactant amount is given in moles, the other reactants must be given in moles as well.
w	Amount given in weight fraction or weight percent. Values for fuels are relative to total fuel. Similarly, values for oxidants are relative to total oxidant. If these values are not normalized, they will be normalized by the program.

Examples:

```

react name O2 moles=.5, ...   name H2 moles=1, ...

reactant fuel CH4 wt%=30 ...
        fuel C6H6 wt%=70 ...
        oxid Air wt%=100 ...

```

2.3.4 Reactant Temperature

For combustion problems (hp, uv, or rocket (ro or rkt)) a temperature must be specified for each reactant whose enthalpy or internal energy value is taken from the product or reactant thermodynamic data files. The temperature value follows a literal that starts with t. Units are indicated by one of the following embedded characters:

Embedded character	Temperature unit
k	Kelvin (default unit if not specified)
r	Rankine
c	Celsius
f	Fahrenheit

Example:

```
react fuel ... t,f=212 ...
oxidant ... t,r=672 ...
fuel= ... t,k=373, ...
```

2.3.5 Assigned Enthalpy or Internal Energy

For a number of problems (hp, uv, or rocket (ro or rkt), detonation (det), or shock (sh)), a value of enthalpy or internal energy must be assigned for each reactant whose value is not taken from *thermo.lib*. The symbols used to specify enthalpy or internal energy and the unit of energy are as follows:

Initial character	Value
h	Assigned enthalpy
u	Assigned internal energy

Embedded characters	Enthalpy or internal energy unit
c	Calories per mole
kc	Kilocalories per mole
j	Joules per mole (default unit if not otherwise specified)
kj	Kilojoules per mole

Examples:

```
react fuel AA ... h,cal/mol=123. t,k=445 ...
fuel BB ... h,j/mol=-9996.3 t,r=100 ...
oxid XX ... h,kj/mol=556 t,r=1000 ...
```

Some additional examples are given in section 2.3.8.

2.3.6 Exploded Chemical Formula

For each reactant the CEA program requires the atomic symbols and their corresponding relative numbers (stoichiometric coefficients). This information must be part of the user's input when the thermodynamic data are not obtained from *thermo.lib*. The requirements for the exploded formula are as follows:

1. Atomic symbols must start with an upper-case letter. A second letter may be either upper or lower case.
2. Relative numbers may be either integers or fractions.

3. The exploded formula is required to be in the **reac** dataset for two situations:
- When the reactant name is not in *thermo.lib*
 - When an enthalpy or an internal energy is given with the reactant input (see section 2.3.8)

Examples (note that spaces are used to separate atomic symbols and numbers):

```

reac name Water-vapor H 2 O 1 ...
      name Species-X Al 6 Si 4 O 9 ...
      name Species-Y C 1 H 1.0769 ...

reac oxid Air N 1.56168 O .419590 Ar .009365 C
      .000319 ...

```

Some additional examples given in section 2.3.8 compare the options of specifying the exploded formula in the **reac** dataset or obtaining it from *thermo.lib*.

2.3.7 Density of Reactant

Calculating the density of the total reactant is an option. It will be calculated according to equations (9.12) and (9.13) in Gordon and McBride (1994) only if a density is given for each reactant in the current **prob** dataset. (Note that this information is not stored in the thermodynamic data library.) Each value follows a variable starting with the letters rho, with possible embedded characters to indicate units as follows:

Embedded characters	Density units
kg	Kilograms per cubic meter
g	Grams per cubic centimeter (default unit if kg is not specified)

Example:

```
reac fuel=B2H6(L) rho,g/cc= .4371 ...
```

2.3.8 Option To Use *thermo.lib*

The exploded chemical formula and either the enthalpy or internal energy for each reactant may be specified in the **reac** dataset or may be taken from *thermo.lib*. If either the exploded chemical formula or a required enthalpy (or internal energy) or both are missing for a reactant in **reac**, CEA will try to find the information in the library by using the reactant name. If a search for a species in *thermo.lib* is successful, the exploded formula and energy data for that species from the library will override any data that might be in the **reac** dataset.

Example (tp problem that does not require an enthalpy):

```
reac ox=O2 wt%=30
```

Since O2 is in *thermo.lib*, the exploded formula will be taken from there.

Examples (all for an hp problem that requires an enthalpy for each reactant):

```
react ox O2 wt%=30
```

gives error message; a temperature must be specified.

```
react ox O2 wt%=30 t,k=300
```

obtains exploded formula and enthalpy (ENERGY/R=6.53777 K) from *thermo.lib*.

```
react ox=O2 wt%=30 t,k=300 h,j/mol=55
```

obtains exploded formula and enthalpy (ENERGY/R=6.53777 K) from *thermo.lib*. This is equivalent to 54.3584 J/mol. The value of $h, j/mol = 55$ in the **react** dataset is overridden because the exploded formula for O₂ was not given.

```
react oxid O2 wt%=30 O 2 t,k=300 h,j/mol=55
```

uses data exactly as specified in the above **react** dataset and does not take any information for this reactant from *thermo.lib*. Specifying a temperature is optional in this example.

```
react ox O2 wt%=30 O 3 t,k=300
```

overrides the exploded formula (given intentionally incorrect as O 3 in the above **react** dataset) and obtains the correct exploded formula O 2 and ENERGY/R=6.53777 K from *thermo.lib*.

```
react ox O2(L) wt%=30 t,k=88
```

selects the one enthalpy value in *thermo.lib* for O2 (L) that corresponds to a temperature of 90.17 K, inasmuch as 88 K is within 10 K of the one *thermo.lib* temperature value of 90.17 K (see section 5.24).

```
react ox=O2(L) wt%=30 t,k=78
```

gives a fatal error message, inasmuch as 78 K is more than 10 K from the *thermo.lib* value of 90.17 K (see section 5.24).

Giving the exploded formula and enthalpy, as illustrated in the fourth example above, is required when the reactant is not contained in *thermo.lib*. Otherwise, unless there is some special reason not to do so, we prefer to use the simple method of obtaining the reactant information from *thermo.lib*, as illustrated in the second example above. In chapter 7, which gives examples of a number of problems, most of the examples use this simple method.

2.4 Dataset prob

The dataset **prob** includes all the input parameters associated with any problem with the exception of reactant information discussed previously. Some of these parameters are required and some are optional.

2.4.1 Case Identification

Case identification is an optional literal or numeric variable that follows the word **case**. The case identification will be printed on the final tables. As mentioned in section 2.1.6 the case identification may start with a number or either an upper- or lower-case letter.

Examples:

```
case=150
```

```
case=example2
```

```
case Example 2
```

(The last example is unacceptable because blanks are not allowed in literal variables.)

2.4.2 Problem Type

For every problem one and only one problem type must be specified. The initial characters for various types of problems are as follows:

Initial characters	Type of problem
tp or pt	Assigned-temperature and -pressure problem
hp or ph	Assigned-enthalpy and -pressure problem
sp or ps	Assigned-entropy and -pressure problem
tv or vt	Assigned-temperature and -volume (or density) problem
uv or vu	Assigned-internal-energy and -volume (or density) problem
sv or vs	Assigned-entropy and -volume (or density) problem
ro or rkt	Rocket problem
sh	Shock problem
det	Chapman-Jouguet detonation problem

2.4.3 Fuel-Oxidant Mixture Values

If the reactant amounts are not completely specified in the **reac** dataset, 1 to 26 numerical values may follow the following initial characters:

Initial characters	Values
%f	Percent fuel by weight
f/o or f/a	Fuel-to-oxidant weight ratios
o/f	Oxidant-to-fuel weight ratios
phi	Equivalence ratios in terms of fuel-to-oxidant weight ratios (eq. (9.19) in Gordon and McBride, 1994)
r	Chemical equivalence ratios in terms of valences (eq. (9.18) in Gordon and McBride, 1994)

Examples:

```
r,eq.ratio= .9, 1, 1.1, 1.5, ...
```

```
%fuel 40 50 60 ...
```

2.4.4 Option To Include Ionized Species

The parameter **ions** instructs the CEA program to consider ionized species as possible products.

Example:

```
problem hp ions case=20 ...
```

2.4.5 Options for Rocket Problems

The following options are available for rocket performance problems:

Initial characters	Option
fac	Assumes a finite-area combustion chamber, fac. If the area is not given, the CEA program will default to the infinite-area combustor assumption, iac.
eq	Assumes equilibrium composition during expansion.
fr or fz	Assumes frozen composition during expansion (not available with fac option).
nfr or nfz	Is followed by integer which is the column number for freezing composition. Default is 1 (the combustion point).
dbg or deb	Prints intermediate output for the fac chamber and throat iteration procedure.

Examples:

```
! Calculate rocket performance parameters assuming
! both equilibrium compositions during
! expansion and compositions frozen at the chamber
! composition.
!
problem rocket equilibrium frozen ...

prob rkt fac dbg ...
```

2.4.6 Options for Shock Problems

The following options are available for shock problems:

Initials characters	Option
inc	Calculate incident shock parameters.
ref	Calculate reflected shock parameters.
eq	Assume equilibrium compositions.
fr or fz	Assume frozen compositions.
dbg or deb	Print intermediate output for shock iteration procedure.

Examples:

```
# Calculate incident shock parameters assuming
# frozen compositions.
#
prob shock inc frz ...

problem shock incident frozen equil reflected ...
```

2.4.7 Temperature Schedule

Assigned values of temperature are required for *tp* or *tv* problems and for initial values for the *det* problem. An assigned combustion temperature is optional for an *iac* rocket problem. From 1 to 26 numerical values may be assigned after the variable starting with *t*, with one of the following embedded characters to indicate units:

Embedded character	Temperature unit
k	Kelvin (the default unit if units are not specified)
r	Rankine
c	Celsius
f	Fahrenheit

Examples:

```
t,k= 3000,2000,1000 ...
t(r) = 2500 2000 ...
prob tp t(r)=2500,2000 500 ...
problem detonation t =298.15 500, ...
```

2.4.8 Pressure Schedule

A schedule of 1 to 26 numerical values for pressure is required for the following types of problems: *tp*, *hp*, *sp*, *ro* or *rkt*, *sh*, and *det*. These values of pressure follow the variable starting with *p*, with one of the following embedded character strings for units:

Embedded characters	Pressure units
bar	Bars (default unit)
atm	Atmospheres
psi	Pounds per square inch absolute
mmh	Millimeters of mercury

Examples:

```
prob tp p,bar=1,10,50 ...
problem rocket p(psia) 1000 500 ...
```

2.4.9 Specific Volume Schedule

A schedule of 1 to 26 numerical values of volume is required for the following types of problems: **tv**, **uv**, or **sv**. This schedule follows the variable starting with **v**, with one of the following embedded character strings for units:

Embedded characters	Volume units
kg	Cubic meters per kilogram
g	Cubic centimeters per gram (default unit if kg is not specified)

Examples:

```
problem tv v,cc/g= 9.e+05 8.e+05, 7.e+07, ...
problem tv v,m**3/kg=900,8.e+03, 7.e+04 ...
```

2.4.10 Density Schedule

A schedule of densities may be specified instead of specific volume for **tv**, **uv**, or **sv** problems (see section 2.4.9). This schedule consists of 1 to 26 numerical values that follow the variable starting with **rho**, with one of the following embedded character strings for units:

Embedded characters	Density units
kg	Kilograms per cubic meter
g	Grams per cubic centimeter (default unit if kg is not specified)

Examples:

```
problem tv rho,g/cc=9.e-05, 8.e-06, 7.e-07 ...
problem tv rho-kg/m**3= .09,8.e-03,7.e-04 ...
```

2.4.11 Assigned Enthalpy

Rocket or **hp** problems require enthalpies to be assigned. Enthalpies of individual reactants may be assigned in the **reac** dataset (see section 2.3.5), or enthalpies for the entire reactant mixture may be assigned in the **prob** dataset. In the latter case, enthalpies must be in

units of h/R [(g-mole)(K)/(g of mixture)]. This value will override any enthalpies that may be given in the **reac** dataset.

Example:

```
prob hp h/r=2345 ...
```

2.4.12 Assigned Internal Energy

The **uv** type of problem requires internal energies to be assigned for the mixture. These energies may be assigned in the **reac** dataset (see section 2.3.5), or internal energies for the entire reactant mixture may be assigned in the **prob** dataset. In the latter case, internal energies must be in units of u/R [(g-mole)(K)/(g of mixture)]. This value will override any internal energies that may be given in the **reac** dataset.

Example:

```
prob uv u/r=1935 ...
```

2.4.13 Assigned Entropy

The **sv** and **sp** types of problems require an entropy of the reactant mixture to be assigned. These entropies must be in units of s/R [g-mole/(g of mixture)].

Example:

```
prob sp s/r=1.363 ...
```

2.4.14 Assigned Values for Shock Problems

Initial Mach numbers (**mach**) or incident shock velocities (**u1**) may be assigned for shock problems. Velocities are in units of meters per second. The number of assigned values for either Mach number or velocity is limited to the number of columns in the output (generally, 13 or 7). In any one particular problem, either parameter may be assigned but not both.

For each of these velocities, there is a corresponding pair of assigned initial temperatures and pressures. If the schedules of temperatures and pressures are not the same length as the **u1** (or **mach1**) schedule, the last value of the **t** or **p** schedule will be used to fill in the missing values. Refer to example 7 in appendix G (or the first example below). For this case, seven **u1** values, no **t** schedule, and two pressures are given in the **prob** dataset. With no **t** schedule, the temperature given with the reactants is used throughout. The first pressure is used for the first **u1** value, and the second pressure is used for the remaining values. If there had been a **t** schedule, these values would be paired one to one with the initial pressure and velocity schedules. Again, if the **t** schedule is too short, the last **t** value will be used to fill in any missing values.

Examples:

```
! EXAMPLE 7: ...
problem case=7 p,mmhg=10,20, shock u1=1000,1100,
1200,1250,1300,1350,1400, incd froz eql ...
```

```
prob case 21 shock incd eql mach1 = 3, 4, 5,  
  t1k=298,320,340, p1bar= .01,.02,.03
```

2.4.15 Assigned Values for Rocket Problems

A number of variables are involved in rocket (ro or rkt) problems. Some are required for all such problems; others are optional. Some comments on the requirements follow:

1. One or more chamber pressures must be assigned. The assignments for chamber pressure follow the rules for pressure discussed in section 2.4.8.
2. Assigning chamber temperature is an option, and the rules for its assignment follow those for temperature discussed in section 2.4.7. (Note that, generally, temperature is not assigned for rocket problems but is determined from the enthalpies of the reactants.)
3. Exit conditions may be assigned either in terms of ratios of chamber pressure to exit pressure or exit area to throat area (see $p_i \dots p$, sub , and sup in the table below).
4. For the f_{ac} option, an assignment must be made for either the contraction ratio (see ac below) or the ratio of the mass flow rate to the chamber area (see $mdot$ below).

The initial characters and a brief description of the rocket variables follow:

Initial characters	Associated numerical values
p	Chamber pressure (see section 2.4.8)
pi...p	Ratio of chamber pressure to exit pressure (P_{in}/P_e or P_{inj}/P_e), not assignable for chamber and throat (1 to 22 values). (Note that the second p in pi...p is embedded. For example, pip, pi/p, pinj/pe, etc.)
sub	Subsonic area ratios (1 to 13 values)
sup	Supersonic area ratios (1 to 13 values)
mdot or ma	For fac option, ratio of mass flow rate to chamber area, (kg/s)/m ²
ac	For fac option, contraction ratio (ratio of finite chamber area to throat area (A_c/A_t))
nfz or nfr	Option for freezing composition at the throat (nfz=2) or at a supersonic exit condition (nfz>2). The output table has equilibrium properties through point nfz and frozen thereafter. If nfz>2, only NCOL - nfz additional exit points are allowed (where NCOL is the number of columns in the output set in the FORTRAN PARAMETER statement, usually 7 or 13).
tcest	Initial chamber temperature estimate in units of kelvin. The default value is 3800 K. (Setting this variable may be necessary only when a condensed species has been inserted in an inse dataset and 3800 K is outside its temperature range.)
t	Assigned chamber temperature, an option (see section 2.4.7)

Examples:

```
prob rocket pi/pe=3,10,30,300, p,psia=3000, froz
tcest=1100 ...
```

```
prob rocket p,bar=50, subsonic,ae/at=5,
supersonic,ae/at=10,20,100, nfz=2
equilibrium frozen
```

```
problem rocket fac p,atm=50, ac/at=1.58,
supar=25,50,75, pi/pe=10,100, ...
```

2.5 Dataset outp

Tables of calculated results are discussed in chapter 3. The **outp** dataset contains several variables that permit some options in these tables. The variables **cal**, **short**, **deb** (or **dbg**), **massf**, and **plot** involve only the output. However, the variables **trac** and **tran** (or **trn**) involve some aspects of the calculation procedure as well. Examples are given in sections 2.5.2 and 2.5.8.

2.5.1 cal

The default unit for energy in the table output is joules. The variable **cal** calls for the output energy unit to be calories.

2.5.2 deb (or dbg)

The variable **deb** permits the printing of intermediate output, which is useful in debugging the iteration process for obtaining the equilibrium composition. The points for which this information is desired can be specified by listing the column numbers.

Examples:

```
outp cal deb=5
output deb=1,4,6
```

For each iteration the data printed include matrix arrays for obtaining corrections to species compositions, current compositions, and corrections to current compositions. This information is printed for each iteration until either equilibrium or the maximum number of iterations permitted by the program is reached.

2.5.3 massf

Until recently, the CEA program permitted equilibrium product compositions in final output tables to be expressed only in terms of mole fractions. The **massf** option in the **outp** dataset now specifies that compositions in the final tables are to be given in mass fractions.

2.5.4 plot

The variable **plot** is to be followed by a list of properties and/or species names whose values are to be stored in the *(input prefix).plt* file in columnar rather than horizontal form. The columns of numerical data in E-format are stored in the order requested. No alphabetic information is stored in this file. The numerical values are in the same units as in the file *(input prefix).out*. Allowance is made for eight columns of mixture properties, including mole or mass fractions, with a maximum of 100 values in each column. If more data are required, more runs can be made. For properties, the initial letters and possible embedded characters are listed following **plot**. For mole or mass fractions (equilibrium only), the full name of each species must be used. (See appendix B for exact names to be used.) Note that the **plot** dump is not currently set up for shock problems. The following variables may be listed:

1. Thermodynamic properties—all problems except shock problems

Initial characters	Property
p	Pressure
t	Temperature
rho	Density
h	Enthalpy
u	Internal energy
g	Gibbs energy
s	Entropy
m	Molecular weight ($1/n$) (eq. (2.3a) in Gordon and McBride, 1994)
mw	Molecular weight (eq. (2.4a) in Gordon and McBride, 1994)
cp	Specific heat
gam	Gamma(s)
son	Sonic velocity

2. Thermal transport properties

Initial characters	Property
vis	Viscosity
cond	Equilibrium thermal conductivity from table of equilibrium properties
cond...fz	Thermal conductivity from rocket output tables assuming frozen composition during expansion. (Note that fz may be embedded anywhere after initial cond.)
pran	Equilibrium Prandtl number from table of equilibrium properties
pran...fz	Frozen Prandtl number from rocket output tables assuming frozen composition during expansion. (Note that fz may be embedded anywhere after initial pran.)

3. Rocket performance parameters—rocket problems only. The following codes are for data from the equilibrium tables. In order to get data from the frozen tables, an *fz* must be embedded in the word after the letters listed. Frozen compositions are the same as the compositions at the equilibrium freezing point and are therefore not dumped. When rocket output tables are more than one page long, the combustion and throat values are repeated for convenience on pages past the first. However, these repeated values are omitted in the *(input prefix).plt* file.

Initial characters	Property
pip	Pressure ratio, P_{inj}/P_e for fac problems and P_{inf}/P_e for iac problems
pi/p	Same as pip
mach	Mach number
ae	Area ratio, A_e/A_t
cf	Coefficient of thrust, C_F
ivac	Vacuum specific impulse, I_{vac}
isp	Specific impulse, I_{sp}

4. Chapman-Jouguet detonation parameters—detonation problems only. The following properties are for unburned gas and all require an embedded 1 after the initial letters:

Initial characters	Property
son...1	Sonic velocity
gam...1	Gamma
h...1	Enthalpy
t...1	Temperature
p...1	Pressure

The following strings may be embedded

Embedded characters	Property
vel	Detonation velocity (e.g., detvel)
mach	Mach number

2.5.5 short

The variable `short` permits printing only the input file, error messages, and final tables. Other information, such as atom ratios and a list of species being considered during the calculations, is suppressed.

2.5.6 trac

The option `trac` instructs the CEA program to print compositions of species with mole or mass fractions greater than or equal to the assigned trace value. When this option is used, the criteria for equilibrium composition convergence are tighter to ensure accuracy of the trace species. With this option, mole or mass fractions are printed in E-format.

2.5.7 tran

The option `tran` (or `trn`) instructs the CEA program to calculate thermal transport properties and add them to the output tables.

2.5.8 Examples of `outp` Datasets

Some examples of `outp` datasets that use the information discussed in the previous sections are as follows:

```
output trace=1.e-10, calories transport short
outp debugcols=1,3
output transport plot=p t CO2 vis cond condgz
output trace=1.e-15 plot pi/p h ivac N2 Ar cpfz
gamfz
outp plot=t1 h1 sonic1 t h detvel mach.number
sonicvel
```

2.6 Options Involving Species To Be Considered

The `only`, `omit`, and `inse` datasets control which species are to be considered by the CEA program either in the current problem or in the current equilibrium composition iteration. If no `only` or `omit` datasets are included in the input for the current problem, all gaseous species in the product thermodynamic data file for the current chemical system will be considered as possible products. (See section 2.6.3 for information on consideration of condensed species.) All three datasets must contain species names exactly as given in the thermodynamic data file with no embedded blanks, tabs, or equal signs. A current list of these species names, which were extracted from *thermo.inp*, is given in appendix B. This list is continually updated.

2.6.1 Dataset **only**

The dataset **only** permits the user to list only those species names from the product thermodynamic data file, *thermo.lib*, that are to be considered in the current problem. Names must be exactly as given in the data file (appendix B) with no embedded blanks, tabs, or equal signs.

Example:

```
only Ar CO CO2 H2 H2O HNO HO2 NH NO N2 O2 OH
```

2.6.2 Dataset **omit**

The dataset **omit** specifies which product species are to be omitted from consideration for the current problem. Species names must be exactly as given in the product thermodynamic data file, *thermo.lib* (appendix B), with no embedded blanks, tabs, or equal signs.

Example:

```
omit C8H17,n-octyl C8H18,isooctane C8H18,n-octane  
C9H19,n-nonyl
```

2.6.3 Dataset **inse**

The dataset **inse** specifies which condensed species are to be included as possible products for the first point in the schedule of points for the current problem. Species names must be exactly as given in the product thermodynamic data file, *thermo.lib* (appendix B). This dataset is usually optional but occasionally may be required to obtain convergence.

Example:

```
insert BeO(L)
```

2.7 Dataset **end**

There are no variables in dataset **end**. The keyword signals the end of input for a particular problem.

2.8 Thermodynamic and Thermal Transport Property Data Bases

Inputs for thermodynamic and thermal transport properties are exceptions to the free form. Generally, they are processed once before running particular problems, and the processed data are automatically saved for further use. The format for representing the thermodynamic data is given in appendix A, and the names of species in the *thermo.inp* file (see below) are given in appendix B. The format for thermal transport property data is given in appendix E. The following keywords start the text on the single records that precede these data bases:

Keyword	Data in succeeding records
ther	Unprocessed (formatted) thermodynamic data. This input file is called <i>thermo.inp</i> . CEA processes the data from <i>thermo.inp</i> and then automatically stores the processed (unformatted) data in a file named <i>thermo.lib</i> (see sections 4.3 and 5.24). After <i>thermo.inp</i> has been processed, it need not be processed again. However, if the user desires to make changes to the <i>thermo.inp</i> file, the new file must be processed. These changes might include adding, deleting, or updating species data or creating special sets of thermodynamic data for special purposes.
tran	Unprocessed (formatted) thermal transport property data. This input file is called <i>trans.inp</i> . CEA processes the data from this file and then automatically stores the processed (unformatted) data in a file named <i>trans.lib</i> (see sections 4.3 and 5.25). The file <i>trans.lib</i> is optional and is required only if thermal transport properties of the reaction mixture are desired. After tran has been called once, it need not be called again.

Chapter 3

Description of Program Output

The program prints five kinds of output: input data used to specify the problem, tables of results, output files for plotting purposes, information concerning iteration procedures, and other intermediate output. The latter three types of output are optional. Examples of problems that generate various types of data are given in chapter 7. The actual tabular outputs for these problems are given in appendix G.

3.1 Input Data

Input data are described in chapter 2. The general procedure used in the CEA program is to list the free-form input data as they are read in and before they are processed by the program. The purpose is to show, as clearly as possible, what is actually on the input records. All problems list the following input data:

1. Comments
2. The **prob** dataset
3. The **reac** dataset
4. The **outp** dataset (if present)
5. The **only** or **omit** dataset (if present)
6. The **inse** dataset (if present)
7. The **end** dataset

3.2 Intermediate Input Data

A number of items of intermediate input information are printed after the input datasets. This intermediate information is often useful for debugging, such as verifying that input data have been correctly interpreted by the CEA program. Printing this intermediate information is optional, however, and may be suppressed by using the option **short** in the **outp** dataset. Intermediate data that are related to input are discussed in the following subsections.

3.2.1 True/False Options

The listing of true/false options contains three lines of information regarding a number of program parameters that have been set "true" or "false" depending on the input data. The first line starts with the word `OPTIONS:`. The default value of all parameters is "false" with the exception of `SIUNIT=T` and `TRACE=0.00000`. The parameters include

1. Specifying the type of problem (TP, HP, SP, TV, UV, SV, DETN, SHOCK, or RKT), one of which has been set to "true"
2. In shock problems, specifying whether incident shocks (`INCD=T`) and/or reflected shocks are to be considered (`REFL=T`)
3. In rocket problems, specifying whether performance is to be calculated based on equilibrium composition during expansion (`EQL=T`) and/or frozen composition during expansion (`FROZ=T`)
4. Specifying whether ionized species are to be considered (`IONS=T`)
5. Specifying that energy unit is to be in calories in final tables (`SIUNIT=F`)
6. Specifying that intermediate information is to be printed during the iteration procedure for `fac` rocket problems (`DEBUGF=T`)
7. Specifying that intermediate information on shock iteration procedures is to be printed (`SHKDBG=T`)
8. Specifying that intermediate information on detonation iteration procedures is to be printed (`DETDBG=T`)
9. Specifying that thermal transport properties are to be calculated and printed in final tables (`TRANSPT=T`)
10. Specifying the value for the `trace` parameter for consideration of minor species. (The default value, `TRACE=0.00000`, instructs the program to print compositions in fixed format only for those species with mole fractions greater than 0.000005.)

3.2.2 Schedules of Assigned Values

These lines list the schedules of parameter values that were read in with the input, such as schedules of temperatures and pressures. For rocket problems, a list of assigned values of area ratios and/or pressure ratios is printed. For shock problems, a list of assigned Mach numbers or incident velocities is printed. For detonation problems, a list of initial temperatures and pressures is printed.

3.2.3 Reactant Information

The reactant information contained in the `reac` dataset is listed in columns to simplify checking the data, if necessary. Some of this information is repeated in the final output tables.

3.2.4 Species Being Considered

This set of species is preceded by the heading SPECIES BEING CONSIDERED IN THIS SYSTEM (CONDENSED PHASE MAY HAVE NAME LISTED SEVERAL TIMES). The species listed are all those in *thermo.lib* that subroutine SEARCH has found to be contained in the current problem's chemical system. Each species in the list is preceded by some identification, such as J12/65. The J (or j) refers to JANAF data (Chase, 1985). The number refers to the month and the year in which the data were published or calculated (12/65 is December 1965). Other identification codes are discussed in McBride et al. (1993). Lower case codes indicate that data have been revised since McBride et al. (1993). These data were fitted with seven coefficients for C_p^o rather than five. If the original data are different, the identification code will be different.

3.2.5 Species With Thermal Transport Properties

If the option `tran` is included in the `outp` dataset, a list of species is printed for which thermal transport property data are contained in the *trans.lib* file. Also printed are those pairs of species for which binary interaction data are contained in the *trans.lib* file.

3.2.6 Enthalpies and Relative Atoms per Kilogram

After the list of chemical species is a listing of the enthalpies or internal energies of the total fuel and oxidant and the total reactant. These values are obtained, respectively, from the following equations in Gordon and McBride (1994): equation (9.6) or (9.8) multiplied by T and equation (9.7) or (9.9) multiplied by T . After this is a list of the kilogram-atom per kilogram of each element in the total fuel and oxidant (eq. (9.1)) and in the total reactant (eq. (9.5)).

3.3 Tables of Results

The final output of the program is in the form of tables that are designed to be self-explanatory. Although each problem has its own kind of table, all the tables have many features in common. These features are

1. Heading
2. Case identification
3. Reactant data
4. Proportion of oxidant to fuel
5. Density of reactant mixture if available
6. Thermodynamic mixture properties and derivatives
7. Thermal transport mixture properties (if `tran` is specified in the `outp` dataset)
8. Equilibrium composition (mole fractions or mass fractions)

3.3.1 Thermodynamic Mixture Properties

The following thermodynamic mixture properties and derivatives are printed for all problems: P , T , ρ , h , s , M ($1/n$), $(\partial \ln V / \partial \ln T)_P$, $(\partial \ln V / \partial \ln P)_T$, c_p , γ_s , and a . The molecular weight MW is also printed when condensed products are present. Two sets of units are currently available for these properties. The default set is the SI set of units. This set is also obtained when `siunit` is specified in the `outp` dataset. The second set is a mixed set of units with energy in calories, temperature in kelvin, pressure in atmospheres, and velocity in meters per second. This set is obtained when `cal` is specified in the `outp` dataset.

3.3.2 Thermal Transport Mixture Properties

Thermal transport properties of the equilibrium mixture are optionally calculated and printed if the `outp` dataset contains the word `tran`. These properties are viscosity and two sets of values for specific heat, thermal conductivity, and Prandtl number. The two sets are based on the assumption of an equilibrium reaction contribution or no reaction contribution (frozen composition). As pointed out in section 5.2.3 of Gordon and McBride (1994), the equilibrium contribution to specific heat is obtained by different methods for the value given in section 3.3.1 and here. For mixtures consisting of gaseous products only, the two values will agree in most cases to all figures given.

3.3.3 Rocket Performance Parameters

In addition to the properties discussed in sections 3.3.1 and 3.3.2, the rocket problem (`rkt` or `ro`) lists the following rocket performance data: P_{inf}/P_e (for the `iac` model) or P_{inj}/P_e (for the `fac` model), Mach number, $A_e/a_p c^*$, C_F , I_{vac} , and I_{sp} . For the `fac` model, the parameters P_{inj}/P_{inf} and either \dot{m}/A_c or A_c/A_t are also listed. These parameters are discussed in chapter 6 in Gordon and McBride (1994).

3.3.4 Shock Parameters

In addition to the properties discussed in sections 3.3.1 and 3.3.2, the shock problem lists data discussed in chapter 7 of Gordon and McBride (1994). For incident shock waves, the parameters listed are M , u_1 , u_2 , P_2/P_1 , T_2/T_1 , M_2/M_1 , ρ_2/ρ_1 , and v_2 . For reflected shock waves, the parameters are u_5 , P_5/P_2 , T_5/T_2 , M_5/M_2 , ρ_5/ρ_2 , and u_5+v_2 .

3.3.5 Chapman-Jouguet Detonation Parameters

In addition to the properties discussed in sections 3.3.1 and 3.3.2, this problem lists the following properties: P/P_1 , T/T_1 , M/M_1 , ρ/ρ_1 , Mach number, and detonation velocity. These parameters are discussed in chapter 8 of Gordon and McBride (1994).

3.4 Intermediate Output Data

The option of printing intermediate output (`deb` or `dbg` in the `outp` dataset) is provided primarily as a means of obtaining additional information for debugging. There is usually no point in using this option when the program is working well. We have used this option in the past for the following reasons:

1. To find programming errors
2. To study the iteration process and rate of convergence
3. To verify that thermodynamic data have been properly prepared
4. To study the test for inclusion of condensed species

3.4.1 Number of Iterations

The output discussed in this section is automatically printed for all problems (except shock problems) unless `short` is included in the `outp` dataset (see section 2.5.5). Following the data discussed in section 3.2.6 is a line containing the terms POINT, ITN, and T and the chemical symbols of the elements for the problem (for example 3 the elements are N, O, Ar, C, and H). The numbers under this heading are printed out after any current estimate converges during the course of the iteration process. The numbers under POINT refer to the columns of data in the final tables. (One exception to this, for the `fac` rocket problem, is discussed at the end of this section.) ITN gives the number of iterations required to converge to equilibrium composition for the current estimate; T is the final temperature for the current estimate. The numbers under the chemical symbols are values of π_i (see section 2.3.1 of Gordon and McBride, 1994). In general there is only one line for each point unless there has been an addition, deletion, or switching of phases of a condensed species (see discussion of example 5, section 7.3).

For rocket and detonation problems, more than one line may be printed for conditions other than a change in condensed species. For a rocket problem, these conditions are for the throat and for an assigned area ratio, where a line is printed out for each estimate of pressure ratio during the iteration process. For example, the four lines for point 6 of example 8, appendix G, which is for an assigned area ratio, show that four separate convergences were required to find the correct pressure ratio for the assigned area ratio. For each of points 7 to 9 two convergences were required. For the throat, additional information is given for pressure ratio and temperature estimates. For a detonation problem, a line is printed for each set of temperature and pressure estimates.

As mentioned earlier in this section, the `fac` rocket problem is an exception to the statement that numbers under the word POINT refer to the columns of data in the final output tables. Solving for the end of combustion chamber and throat conditions in the `fac` problem involves an iteration loop that temporarily includes a point labeled 2 and corresponds to an infinite-area combustor (see section 6.4 of Gordon and McBride, 1994). When this iteration loop is completed, the message END OF COMBUSTOR ITERATION is printed. The data with index 4 (end of combustion chamber) are transferred to index 2 and appear in column 2 in the output tables. Index 3 refers to throat conditions, as usual for the `fac` problem. The next point in the schedule of exit points is assigned as point 4 and corresponds to column 4 in the output tables as usual (see example 9, section 7.6.2).

3.4.2 Iteration Matrices and Compositions

An option is provided to list intermediate output concerning the iteration process for obtaining equilibrium compositions and temperatures. The intermediate data will be listed for all points specified by the parameter `debug` in the `outp` dataset as illustrated in example 14, section 7.10 and appendix G. The option `debug=5` given in the `outp` dataset instructs the program to list intermediate output for point 5.

After the first line, which gives the iteration number, is the iteration matrix corresponding to table 2.1 or 2.2 in Gordon and McBride (1994). The next line contains the words SOLUTION VECTOR and is followed by a line containing the chemical names of the current components. This line is followed by a line containing the solution vector to the matrix. The next line gives the current values of some parameters, that is, T , n (ENN), $\ln n$ (ENNL), P (PP), $\ln(P/n)$ (LN P/N), and the control factor λ (AMBDA). The next group of

lines contains information on the individual species used in setting up the preceding matrix and the values of corrections to compositions. Even though listed under the heading DEL LN NJ, these corrections are $\Delta \ln n_j$ only for gases but are Δn_j for condensed species. The corrections for gases are obtained from the matrix solution and equation (2.18) (for assigned-pressure problems) or equation (2.40) (for assigned-volume or -density problems) from Gordon and McBride (1994). In addition to these corrections the information on the individual species includes the chemical name or formula, n_j , $\ln n_j$, dimensionless enthalpy ($H_{0j}/RT \equiv H_j^\circ/RT$), dimensionless entropy ($S_{0j}/R \equiv S_j^\circ/R$), dimensionless standard-state Gibbs energy ($G_{0j}/RT \equiv \mu_j^\circ/RT$), and dimensionless Gibbs energy ($G_j/RT \equiv \mu_j/RT$). Following this is additional information pertaining to testing for condensed species, which is discussed in the next section.

3.4.3 Condensed-Phases Test

The test for condensed phases is made after every convergence for equilibrium compositions. Details of this convergence test are listed with other intermediate output as part of the debug option discussed in the previous section. After the data for the last iteration, information concerning each condensed species is given. This information consists of the name, the temperature interval for which thermodynamic data exist, and the current number of moles of the condensed species. For those species whose temperature interval bands the current value of temperature, the quantity given by equation (3.7) in Gordon and McBride (1994) (divided by the molecular weight of the species) is calculated and listed with the notation $[(G_{0j} - \text{SUM}(A_{ij} \cdot P_i))]/M$. After all condensed species have been tested, only that species with the largest negative value as shown by MAX NEG DELTA G is included as a possible reaction species, and the iteration procedure is restarted. Dividing the quantity $G_{0j} - \text{SUM}(A_{ij} \cdot P_i)$ by molecular weight usually improves the chances of selecting an appropriate condensed species. The condensed-phases test is illustrated in example 14, section 7.10.

3.4.4 Derivative Matrices

The two derivative matrices (tables 2.3 and 2.4 in Gordon and McBride, 1994) and their solutions are also given for the fifth point of example 14, section 7.10. These derivative matrices are set up after the composition converges. The derivative matrix for derivatives with respect to temperature follows the notation T DERIV MATRIX and is followed by the notation SOLUTION VECTOR and a line containing the solution to the previous set of equations. The derivative matrix for derivatives with respect to pressure follows the notation PDERIV MATRIX and again is followed by the notation SOLUTION VECTOR and a line containing the solution to this matrix. Then several lines of output summarize the results for the point. The printed variables are labeled POINT, P, T, H/R, S/R, M, CP/R, DLVPT, DLVTP, GAMMA(S), and V. The corresponding FORTRAN symbols, defined in appendix F, are Npt, Ppp, Ttt, Hsum, Ssum, Wm, Cpr, Dlvpt, Dlvtp, Gammas, and Vlm, respectively.)

Chapter 4

Modular Form and Modification of Program

To facilitate adding or deleting applications of the program, CEA was organized into eight modules. These modules are concerned with general input, preprocessing of thermodynamic and thermal transport property data, additional input processing, four applications, equilibrium calculations, thermal transport property calculations, and output. The general flow of these modules and associated routines is given in figure 4.1.

A subroutine tree diagram is given in figure 4.2. From this diagram, as well as from figure 4.1, it is clear that, for example, the rocket application could be eliminated by omitting subroutines ROCKET, RKTOUT, and FROZEN and by omitting the statement that calls ROCKET in the main program.

This chapter gives the general purpose of each module. Some details of the individual routines are given in chapter 5.

4.1 Main Program and BLOCKDATA Module

Some details of the main program are described in section 5.1. Among other things, the main program contains all the OPEN and CLOSE statements and interactively calls for the standard input file. It also calls for the routines in two modules:

1. The general input module for processing input (see section 4.2)
2. The applications module for solving various types of problems (see section 4.4)

Flow returns to the main program after the completion of a problem or when a fatal error has occurred.

BLOCKDATA (see section 5.2) is loaded with the program and contains data, such as atomic weights, that remain constant for all problems.

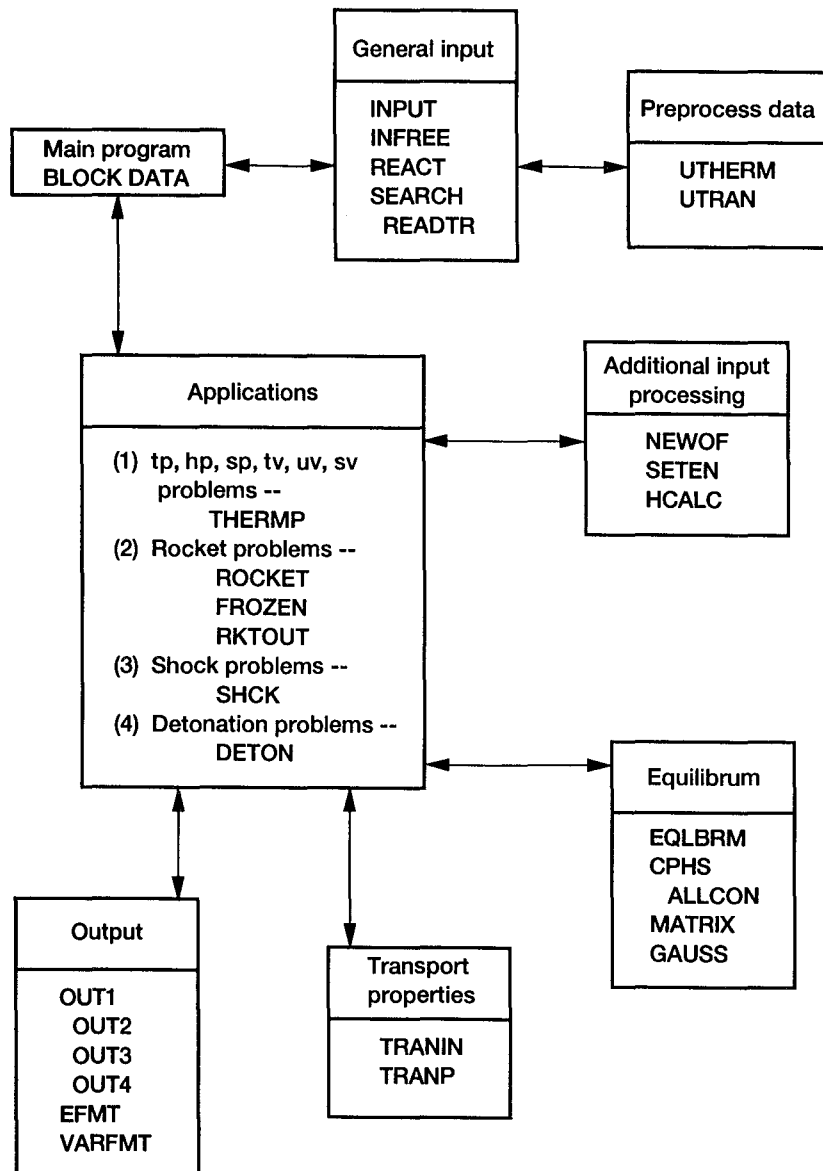

Figure 4.1.—Program modules.

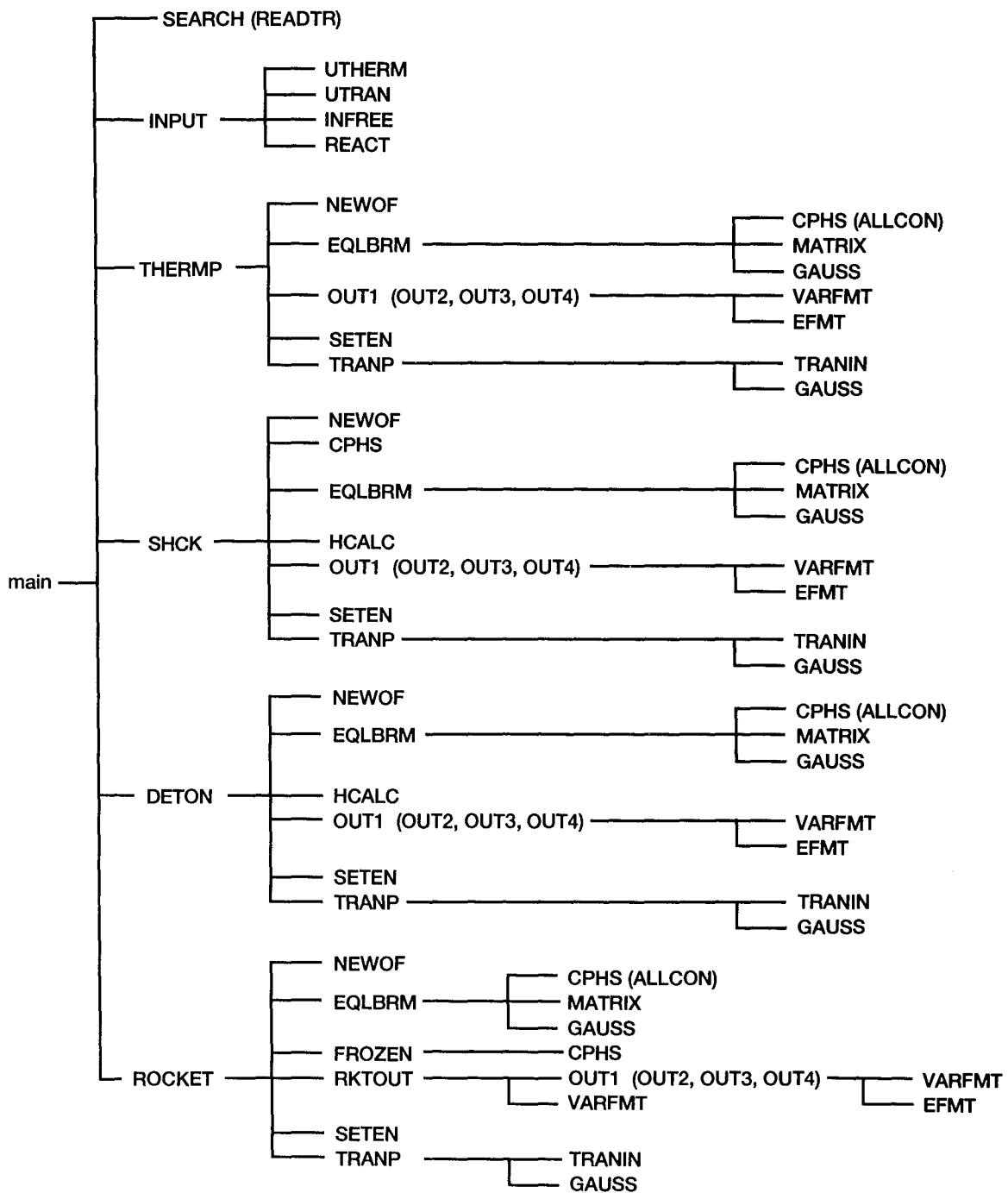

Figure 4.2.—Subroutine tree diagram.

4.2 General Input Module

The general input module contains four subroutines and an entry. The four subroutines and entry are INPUT, SEARCH, entry READTR, INFREE, and REACT. The first three are called from the main program to accomplish the following:

1. INPUT—to read and process input
2. SEARCH—to select the appropriate thermodynamic data for the current problem
3. READTR—to select the appropriate thermal transport property data for the current problem (if transport property calculations have been requested)

Subroutine INFREE is called by INPUT to convert the free-form input data to character and numerical variables. Subroutine REACT is called to process the reactants data. INPUT also calls UATHERM and UTRAN (described in the next section).

4.3 Data-Preprocessing Module

The data-preprocessing module consists of subroutine UATHERM to preprocess thermodynamic data and subroutine UTRAN to preprocess thermal transport property data. Subroutine INPUT calls these routines when it encounters the keywords *ther* and *tran*, respectively. UATHERM reads the formatted data from the *thermo.inp* file, processes the data, and stores the results in unformatted form in the *thermo.lib* file. Similarly, UTRAN reads the *trans.inp* file and stores the processed unformatted data in *trans.lib*. For any particular problem these libraries are searched for the appropriate data for the chemical system of the problem.

These routines have no other connection to the rest of the CEA program. They could be removed and run as separate programs simply for the purpose of preprocessing the thermodynamic and thermal transport property libraries.

4.4 Applications Module

The applications module contains the six subroutines THERMP, ROCKET, SHCK, DETON, FROZEN, and RKTOUT. The first four subroutines are called from the main program according to the type of problem specified in the **prob** dataset. The appropriate subroutine controls the flow of the program until the problem is completed, after which control is returned to the main program. These subroutines do the calculations unique to the problem type. They all call other subroutines in the four modules discussed in sections 4.5 to 4.8 and shown in figure 4.1. For rocket problems only, the other two routines are called from ROCKET (FROZEN for calculating rocket properties based on frozen composition and RKTOUT for printing output unique to rocket problems).

4.5 Additional Input-Processing Module

The application subroutines discussed in the previous section call the three subroutines in this input-processing module to accomplish the following purposes:

1. NEWOF—to adjust the initial variables that vary with assigned fuel-oxidant ratios. These variables include values of b_i^o , ρ_0 , r , and either u_0'/R or h_0'/R for each oxidant-to-fuel ratio. (The variables are defined in Gordon and McBride, 1994.)
2. SETEN—to obtain initial estimates for composition and temperature for a current point from a previously calculated point
3. HCALC—to calculate thermodynamic properties of the reactant mixture for shock and detonation problems only. Enthalpy is always calculated, but specific heat and entropy are calculated only if thermodynamic coefficients are available for the reactants.

4.6 Equilibrium Module

The equilibrium module calculates compositions and thermodynamic properties for a particular point Npt. The module is controlled by subroutine EQLBRM, which calls three subroutines and one entry:

1. CPHS—to calculate thermodynamic functions of the individual gaseous species with entry ALLCON for calculating thermodynamic functions of the individual condensed species
2. MATRIX—to set up the matrices as shown in tables 2.1 to 2.4 of Gordon and McBride (1994)
3. GAUSS—to solve the sets of equations represented by the matrices

Appendix F gives two tables of program variable definitions:

1. Table F1.—COMMON variables that must be initialized prior to entering the equilibrium module
2. Table F2.—COMMON variables that are calculated by the equilibrium module

4.7 Transport Properties Module

The transport properties module consists of two subroutines, TRANIN and TRANP, which are used only if the thermal transport option `tran` appears in the `outp` dataset. TRANIN is called from one of the applications routines for each point Npt after either the equilibrium or frozen thermodynamic properties of the mixture have been calculated. It selects the most abundant gases, reads in any data for these species from input/output unit

IOSCH, and estimates any missing data. It then calls TRANP to calculate the thermal transport properties of the mixture.

4.8 Output Module

The output module consists of the three subroutines, VARFMT, EFMT, and OUT1, with three entries, OUT2, OUT3, and OUT4. OUT1 lists data given in the **reac** dataset as well as o/f , %F, r , and ρ_0 . OUT2 lists the properties P , T , ρ , h , s , $(\partial \ln V/\partial \ln P)_T$, $(\partial \ln V/\partial \ln T)_P$, c_p , γ_s , and a . (The variables are defined in Gordon and McBride, 1994.) OUT3 lists equilibrium mole or mass fractions of the reaction species. OUT4 lists the transport mixture properties η , λ , c_p , and Prandtl number.

Subroutine VARFMT is called from OUT1, OUT2, and OUT3, and subroutine EFMT is called from OUT2 and OUT3. VARFMT adjusts the number of decimal places in a variable format according to the size of the numbers. EFMT sets up a special E-format for printing density ρ and mole or mass fractions.

4.9 Modifications

Many users have modified various versions of the CEA program to meet their particular needs. These changes might include modifying one or more individual subroutines; adding or deleting an entire application; changing dimensions, such as for the number of species or the number of points permitted in a problem; and adding or deleting species to the thermodynamic data file, *thermo.inp*, or the thermal transport property data file, *trans.inp*.

4.9.1 PARAMETER Statements

Some changes concerning dimensions or assignment of input/output units are facilitated by the use of PARAMETER statements. The variables in these statements are defined as follows:

Parameter	Variable for which maximum number is set
MAXNGC	Species that can be considered in any problem. For condensed species, each temperature interval of a species counts as a separate species.
MAXNG	Gaseous products that can be considered in any problem
MAXNC	Condensed-species temperature intervals that can be considered in any problem. The number of intervals may be considerably greater than the number of condensed species.
MAXTR	Gaseous products that can be considered in any problem in thermal transport property calculations
MAXEL	Elements that can be considered in any problem
MAXMAT	Rows permitted in the composition iteration matrix
MAXR	Reactants permitted in a reac dataset
NCOL	Columns of data that can be printed on a page

The numbers to which these parameters are set depends to a large extent on the nature of the problems to which the CEA program is applied. Currently, for the large-scale computer version of CEA, we are using slightly larger numbers than the largest number required in any of many problems that we have run with the program. These numbers for most present-day computers and for smaller capacity computers are as follows:

Parameter	Computer	
	Large scale	Small scale
MAXNGC	600	300
MAXNG	400	200
MAXNC	300	200
MAXTR	50	40
MAXEL	20	15
MAXMAT	50	40
MAXR	24	24
NCOL	13	7 or 8

The names and current assigned values of input/output units in the parameter statements are as follows:

Input/output unit	Current value	File type	Contents
IOSCH	13	Unformatted	Scratch file for processing thermodynamic and thermal transport property data
IOTHM	14	Unformatted	<i>thermo.lib</i> (thermodynamic property data)
IOPLT	15	Formatted	(<i>input prefix</i>). <i>plt</i> file of numerical parameters dumped for plotting purposes
IOTRN	18	Unformatted	<i>trans.lib</i> (thermal transport property data)

4.9.2 Changing Number of Possible Reaction Products

The parameters involved with increasing or decreasing the number of possible products are MAXNGC, MAXNC, and MAXNG. We have found that the numbers set for these parameters for the small-scale version (see previous section) accommodate most problems. However, depending on the user's requirements, these numbers may be reduced considerably more, if so desired. Inasmuch as a single gaseous species requires more than 100 storages, reducing MAXNG by 300 saves more than 30 000 storages.

4.9.3 Eliminating an Application

Any application module may be removed simply by removing the statement calling the controlling subroutine (THERMP, ROCKET, SHCK, or DETON) and then removing the subroutine (or subroutines) in the application module. The calling statements are near the end of the main program.

4.9.4 Adding an Application

An application may be added by means of the following steps:

1. Giving the new type of problem a logical name
2. Revising subroutine INPUT to include all new input variables
3. Programming an applications module (see section 4.4)
4. Calling the module in the main program when the problem name variable is "true" after the input data have been processed in INPUT

Chapter 5

Routines

The CEA program consists of a main program, BLOCKDATA, 24 subroutines, and 5 entries. The function of each of these is described in this chapter. Most of the program variables mentioned in these sections are in labeled COMMON.

5.1 Main Program

Generally, the main program performs the following functions:

1. It uses the OPEN and CLOSE statements to define all input/output (I/O) unit numbers and corresponding files for the entire program. The standard input file uses I/O unit 5. All input data files are required to have the suffix *.inp*. The standard output file uses I/O unit 6 and has the suffix *.out* added to the input file prefix. Four other input/output units are used with numbers defined in PARAMETER statements. See section 4.9.1 for a description of these files.
2. It uses some interactive statements to read input files and to define output files.
3. It calls subroutine INPUT to read and process data from the input file through an **end** dataset or the end-of-file.
4. It calls subroutine SEARCH to read and store thermodynamic data from *thermo.lib* appropriate to the current chemical system processed in the input.
5. It calls entry READTR in subroutine SEARCH if the option *tran* is included in the **outp** dataset. Thermal transport data are read in READTR from input/output unit IOTRN, and data selected for the current chemical system are stored on input/output unit IOSCH.
6. It sets the initial composition estimates as follows:
 - a. E_{nn} —total number of moles per gram of mixture=0.1
 - b. $E_{n(j,1)}$ —number of moles of species *j* per gram of mixture
=0.1/ N_g for gases (where N_g is the number of gases)
=0 for condensed species

7. It inserts any condensed species for consideration that appears in an **inse** dataset.
8. It calls either THERMP, ROCKET, SHCK, or DETON according to the problem type found in the **prob** dataset.

5.2 BLOCKDATA

BLOCKDATA contains the following types of data:

1. Fundamental constants (Cohen, 1987)
2. Data for the chemical elements
3. Initial setup for the variable format array Fmt

The chemical symbols for the elements are stored in the Symbol array; the atomic weights (Anon., 1995), in the Atmwt array; and the valences, in the Valnce array.

The variable format Fmt is used to adjust the number of decimal places in the output variables according to the sizes of the numbers. The format is also used to print a label and from 1 to NCOL associated numbers. NCOL is set by a PARAMETER statement to be the number of columns of output (generally, 7 or 13 depending on the paper width). The labels contain 15 characters.

5.3 Subroutine CPHS

5.3.1 General

Subroutine CPHS is called from subroutines SHCK and EQLBRM. For an assigned temperature T_t , it calculates thermodynamic properties of individual species by using equations (4.9) to (4.11) from Gordon and McBride (1994). These dimensionless properties are for heat capacity, enthalpy, and entropy, respectively. For gaseous species, subroutine CPHS uses one of three sets of coefficients: Coef(j,i,1) for the temperature interval $T_g(1)$ to $T_g(2)$; Coef(j,i,2) for the interval $T_g(2)$ to $T_g(3)$; and Coef(j,i,3) for the interval $T_g(3)$ to $T_g(4)$. The index j ($j=1,Ng$) refers to the j th gaseous species among the Ng gaseous species being considered in the current chemical system, and the index i ($i=1,9$) refers to the i th coefficient. At present the four T_g temperatures in the CEA program are 200, 1000, 6000, and 20 000 K. The calculated properties are stored in the COMMON arrays Cp, H0, and S, respectively.

5.3.2 Entry ALLCON

Subroutine CPHS has an entry ALLCON that calculates the properties of condensed-phase species. ALLCON is called from subroutine EQLBRM. ALLCON calculates thermodynamic properties of all condensed-phase species by using equations (4.9) to (4.11) from Gordon and McBride (1994). Properties are calculated for the current temperature T_t by using the coefficients stored in the Cft(jj,i) array (see section 5.18). The index i is for the i th coefficient, and jj is for the temperature interval ($jj=1,MAXNC$). The temperature intervals are stored in the Temp(2,jj) array. The calculated properties for molar heat capacity,

enthalpy, and entropy are dimensionless and stored in COMMON arrays Cp, H0, and S, respectively.

5.4 Subroutine DETON

Subroutine DETON does the calculations required to obtain Chapman-Jouguet detonation properties as described in chapter 8 of Gordon and McBride (1994). Detonation calculations are limited to gaseous reactants. When initial temperatures are given in the **prob** dataset, subroutine HCALC is called to get the thermodynamic properties of the initial mixture. If the reactant is not found in *thermo.lib*, an error message will be printed. When there is only one initial temperature, it may be specified in either the **prob** or **reac** dataset. In the latter case, if the enthalpy corresponding to the initial temperature is known, it may be included in the **reac** dataset. We usually prefer to specify the initial temperature or temperatures in the **prob** dataset unless the reactant species is not included in *thermo.lib*.

5.5 Subroutine EFMT

Subroutine EFMT (E-format) is called from entries OUT2 and OUT3. It writes statements in a special exponent form. This form is similar to the standard FORTRAN E-format, but the letter E and some of the spaces have been removed for compactness. It is used to write density and mole or mass fractions with the `trace` option.

5.6 Subroutine EQLBRM

Subroutine EQLBRM is the executive routine for calculating equilibrium compositions and mixture properties for point (output column) Npt. It is called from one of the application routines THERMP, SHCK, DETON, or ROCKET. Subroutine EQLBRM, in turn, calls subroutines CPHS, MATRIX, and GAUSS. Before calling EQLBRM, several variables will have already been set, such as the type of problem, the assigned or initial estimated values of the thermodynamic states for the problem, and initial estimates of composition. The COMMON variables that need to be set before entering EQLBRM are tabulated in appendix F (table F.1).

The iteration procedures used in subroutine EQLBRM are described in chapters 2 and 3 of Gordon and McBride (1994). The COMMON variables that are set in EQLBRM for output purposes are given in appendix F (table F.2).

5.7 Subroutine FROZEN

Subroutine FROZEN is called from ROCKET to calculate the temperature and thermodynamic properties for the following assigned theoretical rocket performance conditions:

1. Composition frozen at either combustion (Nfz=1), throat (Nfz=2), or any downstream point (Nfz>2)
2. An assigned exit pressure (Pp)
3. An assigned entropy equal to the entropy at combustion conditions (Ssum(1))

The iteration procedure used for obtaining the exit temperature is discussed in section 6.5 of Gordon and McBride (1994).

If a temperature is reached that is 50 K below the range of a condensed combustion species (Temp(1,j) to Temp(2,j)), calculations are stopped. Then, Tt is set to zero and control is returned to ROCKET where a message is printed and data for all preceding points are listed.

5.8 Subroutine GAUSS

Subroutine GAUSS is called from subroutine EQLBRM to solve the set of simultaneous linear iteration equations constructed by subroutine MATRIX. It is also called from subroutine TRANP to solve the simultaneous linear equations needed to obtain the mixture thermal transport properties. The simultaneous equations are solved by using a modified pivot technique to perform a Gauss reduction. In this modified pivot technique, only rows are interchanged. The row to be used for eliminating a variable is selected on the basis that the largest of its elements, after division by the leading element, must be smaller than the largest elements of the other rows after division by their leading elements.

The solution vector is stored in X(k). In the event of a singularity, Msing is set equal to the number of the first singular row. Msing is tested later in subroutine EQLBRM. In addition, Imat (which is equal to the number of rows) is set equal to Imat - 1.

5.9 Subroutine HCALC

Subroutine HCALC calculates thermodynamic properties for gaseous reactants in shock and detonation problems. It is called from subroutines SHCK and DETON only when there is a τ schedule in the **prob** dataset. If the reactants are species that are included in the first part of *thermo.lib* (containing data for products), the thermodynamic coefficients will have already been stored in the common variable Coef(j,i,k), and these coefficients will be used to obtain the required thermodynamic properties. If the coefficients are in the last part of *thermo.lib* (reserved for reactants only), *thermo.lib* will be searched for the appropriate coefficients. If found, they will be stored at the end of the data already stored in the Coef array. The first index in this array indicates the species number. For the reactants these numbers are stored in the Jray array for future use. Subroutine HCALC also calculates the properties of the reactant mixture. The mixture properties h_0/R , c_0/R , and s_0/R (eqs. (9.7), (9.21), and (9.22), respectively, in Gordon and McBride, 1994) are stored in Hsub0, Cpmix, and Ssum(Npt), respectively, for the current temperature Tt.

5.10 Subroutine INFREE

Subroutine INFREE is called from subroutine INPUT. It reads, writes, and analyzes input for a complete dataset. As many as 132 characters are read and sorted for each record. The record is just printed without further analysis if the characters are all blanks and tabs or if the first nonblank or nontab character is a “#” or an “!”. Character strings are formed by concatenating the characters between one or more special characters defined to be delimiters (see section 2.1.7). These strings are stored in the call-vector character array Cin. Variables starting with a “+”, a “-”, or an integer are assumed to be numeric. Other Cin variables are assumed to be literal.

Delimiters can be any consecutive combination of blanks and tabs. Other delimiters are an equal sign following a literal variable and a comma following a numerical variable. Numerical variables are converted to double-precision variables and stored in the Dpin array. The variables in the call vector are defined as follows:

Variable	Description
Code	Cin(1) assumed to be the keyword
Readok	Logical variable that is set to “false” when either there is an error in reading a record or a keyword is not found
Cin	Character strings between delimiters. As many as 15 characters are stored. Additional characters are ignored.
Ncin	Number of variables stored in Cin
Lcin	Integer array giving information about corresponding variable in Cin as follows: <ol style="list-style-type: none">1. If Cin(i) is literal, Lcin(i) gives the number of characters with a negative sign.2. If Cin(i) is numeric, Lcin(i) gives the index of the previous literal.
Dpin	Array with numerics in Cin converted to double precision
Ndp	Integer giving the number of double-precision numbers in Dpin

5.11 Subroutine INPUT

Subroutine INPUT calls subroutine INFREE, which deciphers the characters in the free-form input. (See subroutine INFREE, section 5.10, for definitions of the call-vector variables.) It then checks for keywords. The data corresponding to the keywords are processed and stored as follows:

1. For the keywords **only**, **inse**, and **omit**, species names are stored in the COMMON variables Prod, Ensert, and Omit, respectively.
2. For the keywords **outp**, **reac**, and **prob**, the dataset information stored by subroutine INFREE in the Cin, Lcin, and Dpin arrays is examined, and the required COMMON data are stored.

3. For the keyword **reac**, subroutine REACT is called for further processing the **reac** data.
4. For the keyword **prob**, the literals that do not have associated numerical data are sorted and stored first. The numerical data are then analyzed and stored.
5. For the keywords **thermo** and **tran**, subroutines U THERM and U TRAN are called, respectively, to process and convert the thermodynamic and thermal transport data to unformatted form.
6. For the keyword **outp**, if plotting parameters are listed, the input/output unit IOPLT is opened, and numerical data corresponding to the parameters are dumped as a (formatted) text file to input/output unit IOPLT. The file contains no alphanumeric information. Data that are generally listed horizontally in the standard output are listed vertically in this file. This file is named with the same prefix as the standard input but with the suffix *.plt*.
7. For the keyword **end**, after some additional processing, control is transferred to the main program.

5.12 Subroutine MATRIX

Subroutine MATRIX is called from subroutine EQLBRM to set up an appropriate matrix corresponding to one of tables 2.1 to 2.4 in Gordon and McBride (1994). These matrices are set up for the following purposes:

1. The matrix in table 2.1 corresponds to the iteration equations for determining equilibrium compositions for the following assigned-pressure problems:
 - a. **tp** (assigned temperature and pressure) (**Tp=.TRUE., Vol=.FALSE.**)
 - b. **hp** (assigned enthalpy and pressure) (**Hp=.TRUE., Vol=.FALSE.**)
 - c. **sp** (assigned entropy and pressure) (**Sp=.TRUE., Vol=.FALSE.**)

The logical variable **Convg** is "false" for these three problems.

2. The matrix in table 2.2 corresponds to the iteration equations for determining equilibrium compositions for the following assigned-volume (or -density) problems:
 - a. **tv** (assigned temperature and volume or density) (**Tp=.TRUE., Vol=.TRUE.**)
 - b. **uv** (assigned internal energy and volume or density) (**Hp=.TRUE., Vol=.TRUE.**)
 - c. **sv** (assigned entropy and volume or density) (**Sp=.TRUE., Vol=.TRUE.**).

These matrices are initially set up like those in table 2.1, and then, where necessary, elements of the matrices are corrected to match table 2.2. The logical variable **Convg** is false for these three problems.

3. The matrix in table 2.3 corresponds to the equations for calculating derivatives with respect to the logarithm of temperature at constant pressure. The logical variables are set

the same as for the matrices of tables 2.1 and 2.2 except for setting Conv_g=.TRUE. and Pderiv=.FALSE.

4. Similarly, the matrix in table 2.4 corresponds to the equations for calculating derivatives with respect to the logarithm of pressure at constant temperature. The logical variables are set the same as for table 2.3 except for Pderiv=.TRUE.

The elements in the matrices ($G(i,j)$) are generally summations of properties of product species. The matrix is cleared and then filled by two DO loops—one for gases ($j=1,Ng$) and one for condensed species ($k=1,Npr$). The appropriate contribution of each species is summed into the matrix elements.

5.13 Subroutine NEWOF

Subroutine NEWOF combines the properties of total oxidant and total fuel (calculated either in subroutine REACT or subroutine HCALC) for a particular oxidant-to-fuel ratio to give properties for the total reactant. NEWOF is called from either THERMP, ROCKET, SHCK, or DETON for each mixture ratio that was set in subroutine INPUT (Oxf array). The total reactant properties are calculated by using equations (9.5) to (9.22) from Gordon and McBride (1994). Values of $b_i^{(2)}$, $b_i^{(1)}$, and b_i^o (eqs. (9.1) and (9.5)) are printed for all problems. For problems with an assigned pressure, values are printed out for $h^{(2)}/R$, $h^{(1)}/R$, and h_o/R (eqs. (9.6) and (9.7) multiplied by T). For problems with an assigned volume or density, values are printed out for $(u')^{(2)}/R$, $(u')^{(1)}/R$, and u_o'/R (eqs. (9.8) and (9.9) multiplied by T). The initial value of the Size variable discussed in section 3.2 of Gordon and McBride (1994) is set in NEWOF. Adjusting Size for the value of Bratio is also done in this routine.

5.14 Subroutine OUT1

Subroutine OUT1 and entries OUT2, OUT3, and OUT4 write statements in the final output tables that are common to all problems. They are called from subroutines THERMP, ROCKET, DETON, and SHCK. Subroutine OUT1 writes the following information:

1. Case name or number
2. Reactant names and properties
3. Mixture values (oxidant-to-fuel ratio, percent fuel, and the two equivalence ratios defined in equations (9.18) and (9.19) of Gordon and McBride, 1994)
4. Reactant densities (if values are included in the input)

5.14.1 Entry OUT2

Entry OUT2 writes the final tables of the thermodynamic mixture properties and stores any requested plot data in the Plout array. These variables and their corresponding labels are printed horizontally across the page with a variable format. Some format adjustments are made by calling subroutines VARFMT and EFMT. The maximum number of

columns of data on a page will vary depending on how the NCOL parameter is set in the PARAMETER statements. For wider paper, NCOL=13 works well. For 8 1/2×11-in. paper NCOL=7 works well.

The data that are dumped into the Pltout array are in the same units as the labeled listed data. They are listed vertically, however, rather than horizontally and there is no alphabetic output. The columnar data are in the same order as requested in the **outp** dataset. The Pltout array is dimensioned for eight parameters, each with 100 values. Mole or mass fractions may also be dumped into Pltout (see section 5.14.2).

5.14.2 Entry OUT3

Entry OUT3 writes product species names and equilibrium mole or mass fractions for the final tables. If any product names are listed for plotting, their mole or mass fractions will be dumped into the Pltout array in columns rather than in the horizontal form shown in the tables. All species are listed that have mole or mass fractions for at least some of the assigned conditions which are either greater than 5×10^{-6} or greater than the trace value if trace is given in the **outp** dataset. Unless the short output option has been specified, the names of the species with mole or mass fractions less than this amount for all assigned conditions will be listed at the end of the table. With the trace option, subroutine EFMT is called for printing mole or mass fractions in an E-format in order to retain more figures.

5.14.3 Entry OUT4

Entry OUT4 writes the values of thermal transport mixture properties in the final tables and also stores any of these properties that are requested for plotting purposes. The comments in the last paragraphs of sections 5.14.1 and 5.14.2 pertaining to number of columns and dumping for plotting purposes apply to transport properties as well.

5.15 Subroutine REACT

Subroutine REACT is called from subroutine INPUT to further process reactant data. Subroutine REACT does the following for each reactant:

1. Searches the *thermo.lib* file for a species with the same name as the reactant if one of the following is true:
 - a. The exploded formula is missing.
 - b. An assigned enthalpy value is missing for a rocket or hp problem.
 - c. An assigned internal energy value is missing for a uv problem.

For the case where *thermo.lib* has data for only one temperature (usually a transition point or 298.15 K), the temperature given in the input must be within 10 K of the *thermo.lib* value. Otherwise, the program will print a fatal error message. Some examples are given in section 2.3.8.

2. Calculates the enthalpy or internal energy from the coefficients in *thermo.lib* for (1b) or (1c) above.
3. For each new chemical element for the current problem, obtains the following data from BLOCKDATA (section 5.2) and stores them in their corresponding arrays: chemical

symbol in Elmt, atomic weight in Atwt, and valences in temporary storage. These valences are then used to calculate plus-and-minus valences for both total fuel and total oxidant that are stored in Vpls and Vmin (see eqs. (9.14) and (9.15) in Gordon and McBride, 1994).

4. Calculates the molecular weights of total oxidant $M^{(1)}$ and total fuel $M^{(2)}$ and stores values in the Am array (see eq. (9.10) in Gordon and McBride, 1994).
5. Determines if the reactant is labeled oxid, fu, or na. Reactants labeled na and fu are treated alike during further processing. Program variables relating to oxidants or fuels are indexed 1 for oxidants and 2 for fuels.
6. Adds the reactant contribution to the total oxidant or total fuel properties (see chapter 9 of Gordon and McBride, 1994).

If there are several reactants labeled fu or na, their properties are combined into properties of a total fuel by using the relative proportion of each fuel given in the **reac** dataset. Labeled oxidant species are also combined. These total fuel and oxidant values are later combined with oxidant-to-fuel ratio values in subroutine NEWOF to obtain total reactant properties. Equation (9.12) in Gordon and McBride (1994) gives the density of total oxidant $\rho^{(1)}$ (Rh(1)) and total fuel $\rho^{(2)}$ (Rh(2)). If any one of the densities used in equation (9.12) is zero, Rh(1)=Rh(2)=0.

5.16 Subroutine RKTOUT

Subroutine RKTOUT is called from ROCKET. It is the control program for writing the final output tables for rocket problems. It calculates various rocket performance parameters from previously calculated and stored thermodynamic mixture properties. It also stores any requested plot data involving rocket performance in the Pltout array. It calls subroutine OUT1 and entries OUT2 and OUT3 to write output common to all problems. The rocket parameters are printed with the variable format Fmt described in section 5.2.

5.17 Subroutine ROCKET

Subroutine ROCKET is the control program for rocket performance calculations described in chapter 6 of Gordon and McBride (1994). It is called from the main program if the problem type rkt or ro is included in the **prob** dataset. Subroutine ROCKET selects the appropriate iteration scheme for the assigned combustion chamber model fac or iac. It obtains the required thermodynamic properties for equilibrium performance by calling subroutine EQLBRM. For frozen performance, subroutine ROCKET calls subroutine FROZEN to obtain the required thermodynamic properties. It calls subroutine TRANP to obtain thermal transport properties if trn or tran has been included in the **outp** dataset.

The assignment of parameters for various points in the rocket problem is handled by various loops. An outer loop calls NEWOF for each new value of oxidant-to-fuel ratio. Another loop assigns chamber pressures. Within this loop are other loops for assigned exit conditions. For the exit conditions, assigned pressure ratios, if any, are processed first; then, assigned subsonic area ratios, if any; and finally, assigned supersonic area ratios, if any.

Subroutine RKTOUT is called for preparing output tables when either a page is filled (Npt=NCOL) or all exit points have been calculated for equilibrium compositions first and then for frozen compositions.

5.18 Subroutine SEARCH and Entry READTR

Subroutine SEARCH is called from the main program to search the *thermo.lib* file for thermodynamic data of possible products appropriate for the current chemical system. Data for all these species will be stored for consideration except for two situations:

1. When an **only** dataset specifies the species to be considered
2. When an **omit** dataset specifies the species to be omitted

For those selected species, the names are stored in the Prod(j) array, where j is the species index; the stoichiometric coefficients (index i) are stored in the A(i,j) array; and the thermodynamic coefficients (index i) are stored in the Coef(j,i,k) array for gases (where k is the temperature interval index) and in the Cft(j,i) array for condensed species. Since gases precede condensed species in *thermo.lib*, their names come first in the Prod(j) array. These names have a limit of 15 characters. The data for reactants only, which appear in *thermo.lib* after the data for all the products, are not stored in subroutine SEARCH but are stored in subroutine REACT. For condensed species, the name (including the phase), as well as the thermodynamic coefficients, is stored for each temperature interval. The total number of these stored condensed species names or temperature intervals is Nc. Therefore, the total number of stored names Ngc, including gases and condensed species, is $Ngc = Ng + Nc$. (Ngc is also the total number of gaseous species and condensed-phase temperature intervals.) Since the maximum values of Ng and Nc are MAXNG and MAXNC, respectively, the thermodynamic coefficients are dimensioned Coef(MAXNG,9,3) and Cft(MAXNC,9). If the short option is not used, the names in the Prod array are listed along with the date code stored with the data in *thermo.lib*.

If tran has been included as an option in the **outp** dataset, entry READTR is called from the main program to read thermal transport properties from *trans.lib* (stored on input/output unit IOTRN). Data for species with the same names as contained in the thermodynamic property data (Prod(j)) are stored in a scratch file IOSCH (I/O unit 13) for use in calculating mixture properties. Additional processing of thermal transport properties is discussed in section 5.22.

5.19 Subroutine SETEN

Subroutine SETEN is called from an application subroutine such as THERMP, SHCK, DETON, or ROCKET. It has several functions, all of which are concerned with saving some information from a completed calculation for subsequent use in later calculations. The primary purpose is to have reasonably good initial composition estimates for new points.

These estimates for the next point Npt come from either the point just completed Isv or some other previous point. The flow of the routine is directed by Isv as follows:

1. Isv positive—transfers compositions for the point just completed for use as initial estimates for the next point (transfer En(j,Isv) to En(j,Npt))
2. Isv negative—makes Isv positive and saves values of Enln(j) for gases and En(j,Isv) for condensed phases in Sln(j), Enn in Ensave, Ennl in Enlsav, Ttt(Isv) in tsave, and Lsave in lsav. (These values are saved because they are to be used as initial estimates for some future point and they may be overwritten in the meantime.) Values in En(j,Isv) are transferred to En(j,Npt). If the Isv point has two included condensed phases of the species, the indices for these species will be Jliq (for the higher temperature phase) and Jsol (for

the lower temperature phase). For this situation, $En(Jliq,Isv)$ is combined with $En(Jsol,Isv)$ and $En(Jliq,Isv)$ is excluded. This procedure usually helps in obtaining convergence for the next point and other future points that start with the saved estimates.

3. Isv zero—uses the data previously saved (as discussed in (2) above) as initial estimates for the current point.

5.20 Subroutine SHCK

Subroutine SHCK is the application module for shock problems. It is called from the main program and calls the following subroutines: NEWOF, CPHS, EQLBRM, HCALC, OUT1, OUT2, OUT3, OUT4, SETEN, and TRANP. When initial temperatures are given in the **prob** dataset, subroutine HCALC is called to get the thermodynamic properties of the initial mixture. It calculates the shock parameters discussed in chapter 7 of Gordon and McBride (1994). For every assigned mixture, subroutine SHCK calculates properties for as many as NCOL assigned initial velocities or Mach numbers. NCOL is the number of columns in the output listing—generally, 7 or 8 for 8 1/2×11-in. paper and 13 for wider computer paper. Depending on the input options specified in the **prob** dataset, it calculates incident shock conditions based on equilibrium compositions after shock and/or based on compositions frozen at initial conditions. It also calculates, on the basis of specified options, frozen and/or equilibrium reflected shock conditions relative to the equilibrium and/or frozen incident shock conditions.

5.21 Subroutine THERMP

Subroutine THERMP is called from the main program to execute tp , hp , sp , tv , uv , and sv problems. Since EQLBRM calculates equilibrium compositions and mixture properties for one point at a time (see sections 2.3 and 2.4 of Gordon and McBride, 1994), THERMP sets up the necessary parameters for each point. This involves all combinations of oxidant-to-fuel ratios for all problems; assigned pressures for tp , hp , and sp problems; assigned volumes (or densities) for tv , uv , or sv problems; and either the estimated or assigned temperatures for all problems.

These parameters are assigned by means of three nested DO loops. The outermost loop is the Nof array of oxidant-to-fuel ratios. For each of these ratios, subroutine NEWOF is called to obtain the reactant mixture properties. The next loop is for the Np assigned pressures or volumes. Finally, the innermost loop is for temperature. For tp and tv problems, there are Nt assigned temperatures. For hp , sp , uv , and sv problems, $Nt=1$ and the initial temperature estimate for the first point is 3800 K. Succeeding initial estimates for new points are taken from the results of previous points. Subroutine EQLBRM is called in the temperature loop. Following the EQLBRM call, subroutine TRANP is called to calculate thermal transport properties if the $tran$ option was included in the **outp** dataset. The initial estimate routine SETEN and the output routines OUT1, OUT2, OUT3, and OUT4 are called at appropriate times.

5.22 Subroutine TRANIN

Subroutine TRANIN is called from subroutine TRANP for each point to perform the preliminary steps for calculating thermal transport properties of the current mixture.

TRANIN first determines which species have the largest mole fractions. It next reads in the properties for these largest individual species and binary interactions containing these species from input/output unit IOSCH, estimates missing data, and eliminates species unimportant for transport property calculations. Subroutine TRANP then solves the necessary equations to obtain the thermal transport mixture properties.

Some processing accomplished in TRANIN is as follows:

1. For shock problems with the frozen composition option, mole fractions of the reactants are calculated and their thermal transport data are stored.
2. The En array is searched for atomic gases and species whose mole fraction is greater than 1×10^{-11} . The indices of the selected species are stored in the Ind array, with indices for the atomic gases stored first, followed by indices of other species stored generally in order of largest species first. A maximum of MAXTR species is allowed, where the number for MAXTR is set in a PARAMETER statement.
3. Mole fractions are recalculated by using only the compositions of the selected species.
4. Stoichiometric coefficients from the A array are copied into the Stc array in order to express them as a set of chemical reaction equations as required in equation (5.10) of Gordon and McBride (1994).
5. Thermal transport properties from input/output unit IOSCH are read in for the selected set of species. IOSCH is a scratch unit with properties for species appropriate to the current chemical system. IOSCH was written in entry READTR (subroutine SEARCH).
6. Estimates for thermal transport properties are made for those selected species for which no data exist in IOSCH. For neutral species, the estimating formula is

$$\bar{\Omega}_{ij}^{(2,2)} = \ln \left(\frac{50 M_j^{4.6}}{T^{1.4}} \right)$$

This formula is a slightly modified version of equation (39) of Svehla (1973). It is used in equation (7c) in Svehla (1973) to obtain viscosity. For ionized species or ion-neutral pairs, estimating formulas were taken from Gupta et al. (1990).

5.23 Subroutine TRANP

Subroutine TRANP calculates mixture thermal transport properties as described in Gordon and McBride (1994). It is called only if the term `tran` has been included in the **outp** dataset in the standard input file. In that case, it is called for every point from one of the application routines, namely DETON, ROCKET, SHCK, or THERMP. Subroutine TRANIN is called to read in or estimate thermal transport property data for pure species or pairs of species. The reaction contribution to thermal conductivity and heat capacity involves solving sets of simultaneous linear equations. The matrix elements for these equations are calculated in subroutine TRANP, and subroutine GAUSS is called to solve the equations.

5.24 Subroutine UATHERM

Subroutine UATHERM is called from subroutine INPUT after the keyword **thermo** is read. UATHERM reads thermodynamic data from *thermo.inp*, which is a formatted (text) standard input file (i.e., input/output unit 5). For the most part, the data are in the form of least-squares coefficients as discussed in section 4.2 of Gordon and McBride (1994).

Data are stacked in *thermo.inp* in the following order:

1. Keyword **thermo**
2. Temperature intervals for the gaseous species
3. Sets of data for the gaseous product species
4. Sets of data for the condensed product species
5. END PRODUCTS record
6. Data for reactants only

The format for these data is given in appendix A. When subroutine INPUT reads the keyword **thermo** in the main program, it calls subroutine UATHERM to process the thermodynamic data that follow and to store them for further use in unformatted form in the *thermo.lib* file (input/output unit IOTHM). Input/output unit IOSCH is a scratch unit that is used in connection with the processing of the thermodynamic data. UATHERM sorts and counts the number of species sets. The sorting process stores all gaseous species ahead of all condensed species. The total number of gaseous species is stored in Ng, and the total number of condensed-phase temperature intervals is stored in Nc. (Note that each condensed-phase temperature interval is counted as a separate species.) The index Ngc contains the sum of the other two indices (i.e., $Ngc = Ng + Nc$). The current CEA program allows for three temperature intervals for gaseous species and a variable number of intervals for condensed phases. The standard set of gaseous species data that accompanies the CEA program is divided into the following three temperature intervals: 200 to 1000 K, 1000 to 6000 K, and 6000 to 20 000 K. However, most gaseous products exist in negligible amounts above 6000 K, and therefore no thermodynamic data are provided for the highest temperature interval for most of the species. During the iteration process, to obtain equilibrium compositions in the highest temperature interval, it may be necessary to have the missing thermodynamic data, at least temporarily, in order to obtain convergence. Subroutine UATHERM estimates these missing data by means of a straight line for C_p . The equation for the straight line is generated from the values of C_p at 6000 and 20 000 K, using the classical value at infinity for the value at 20 000 K.

The data for reactants are stored after the data for gaseous or condensed products. For some reactants, thermodynamic data (in the form of coefficients) are given over a temperature range. For other reactants, only one assigned enthalpy value is given at some specified temperature (usually 298.15 K or some transition temperature). For example, for O₂(L), only one enthalpy value is given (at the boiling point of 90.17 K).

Any set of thermodynamic data needs to be read in and processed only once. If changes are made to the data, by adding, removing or changing data for various species, the new set will need to be read in. (However, data for one or more species may also be omitted from consideration during any particular run without reading in a new dataset by the use of the **omit** and **only** input datasets.)

5.25 Subroutine UTRAN

Thermal transport property data (viscosity and thermal conductivity) are read as formatted data from standard input (i.e., input/output unit 5). The data are in the form of least-squares coefficients as discussed in chapter 5 of Gordon and McBride (1994). Subroutine UTRAN processes these data and stores them for further use in unformatted form in the *trans.lib* file (input/output unit IOTRN). Input/output unit IOSCH is a scratch unit that is also used in processing the transport property data. Subsequently, in entry READTR (subroutine SEARCH), transport data for the current chemical system under consideration are stored in input/output unit IOSCH.

5.26 Subroutine VARFMT

Subroutine VARFMT (variable format) is called from entry OUT2 and subroutine RKTOUT. It adjusts the number of decimal places printed in F-format in the variable format Fmt according to the size of the number. It is used for P_{in}/P_e or P_{inj}/P_e , P , and A_e/A_t . The variable format is described in section 5.2.

Chapter 6

Error Messages

This chapter contains a list of error messages and warnings and some discussion concerning them. The messages are grouped in alphabetical order within each subroutine in which they appear. The name of the subroutine is given in parentheses at the end of each message.

6.1 DETON Message

CONSERVATION EQNS WERE NOT SATISFIED IN 8 ITERATIONS (DETON)

Fatal error. Conservation equations for the detonation problem usually converge in three or four iterations. The program limits the number of iterations to eight, although we have never run a problem that required this many iterations. Therefore, we have not yet seen this message printed. If the message were to be printed, the program would skip to the next problem.

6.2 EQLBRM Messages

CALCULATIONS STOPPED AFTER POINT (number) (EQLBRM)

If a fatal error occurs in subroutine EQLBRM, this message will be printed, output tables for any completed points will be printed, and control will be returned to the main program, which continues with the next problem, if any.

(Number of) CONVERGENCES FAILED TO ESTABLISH SET OF CONDENSED SPECIES (EQLBRM)

Fatal error. The CEA program will attempt to obtain the correct set of condensed species up to $3 \times N_{lm}$ times, where N_{lm} is the number of chemical elements in the system. If the program is unsuccessful after this number of attempts, this message will be printed as well as the previous message.

DERIVATIVE MATRIX SINGULAR (EQLBRM)

If singularities occur in the matrix solutions, they generally occur first in the iteration matrices and the program does not get as far as the derivative matrices. However, it is possible for the iteration matrix to just barely avoid being singular and for the derivative matrix to be

singular. When this occurs, this message is printed, *Dlvpt* is set equal to -1, *Dlvtp* is set equal to 1 (see appendix F for definitions), and the program continues.

DID NOT CONVERGE ON ELECTRON BALANCE (EQLBRM)

Fatal error. As discussed in section 3.7 of Gordon and McBride (1994), a special iteration procedure is used for ions. For all problems tried, this procedure has been successful in meeting the convergence criterion for ions. In the event convergence is not reached, this message is printed as well as the first EQLBRM message.

(Number of) ITERATIONS DID NOT SATISFY CONVERGENCE REQUIREMENTS FOR THE POINT (Number) (EQLBRM)

Fatal error. The maximum number of iterations permitted to obtain convergence is either $50 + N_s/2$ if *trace* is included in the **outp** dataset or 50 otherwise. Generally, convergence is obtained in considerably fewer iterations. The number $50 + N_s/2$ was somewhat arbitrarily selected to indicate that, if convergence has not been reached by that number, the problem probably will not converge at all. This situation occurs rarely. When it occurs, this message is printed, as well as the first EQLBRM message. If the cause of nonconvergence is not obvious from the output, it may be helpful to rerun the problem with intermediate output. An examination of this output often pinpoints the source of the difficulty.

LOW TEMPERATURE IMPLIES A CONDENSED SPECIES SHOULD HAVE BEEN INSERTED. RESTART WITH *insert* DATASET (EQLBRM).

Fatal error. This message can occur only for an *hp* or *uv* problem. It occurs only when the omission of an important condensed reaction product causes the program to seek a combustion temperature that is unrealistically low ($T < 100$ K). When this occurs, the message is printed as well as the first EQLBRM message.

REINSERTION OF (name of species) LIKELY TO CAUSE SINGULARITY (EQLBRM)

Fatal error. In the process of inserting and removing condensed species, the program may attempt to insert a condensed species that it had just removed during the previous iteration cycle. To prevent a possible infinite cycle, this message is printed as well as the first EQLBRM message.

SINGULAR MATRIX, ITERATION (number) VARIABLE (number) (EQLBRM)

This message is printed whenever a singularity occurs during the matrix solution. As discussed in section 3.6 of Gordon and McBride (1994), several procedures are used in special singularity situations to obtain convergence. If none of the special techniques resolve the problem, the first EQLBRM message is also printed.

THE TEMPERATURE = (degrees K) IS OUT OF RANGE FOR POINT (number) (EQLBRM)

Except for the shock problem, this message is printed whenever the converged temperature for the indicated point is outside the temperature range read in on the second record of the *thermo.inp* file. This temperature range, which at present is 200 to 20 000 K, is the one over which some of the gas-phase thermodynamic data have been fitted. Generally,

the thermodynamic data can be extrapolated a short distance without much loss in accuracy. However, to prevent large errors due to extrapolation, the current temperature T_t is not permitted to be less than a factor of 1.5 below the lowest temperature in the range or more than a factor of 1.25 above the highest temperature in the range. If temperature is outside these limits, then after the above message has been printed, the first EQLBRM message is also printed.

TRY REMOVING CONDENSED SPECIES (EQLBRM)

As discussed in section 3.6 of Gordon and McBride (1994), several techniques are tried to obtain convergence after a singularity has occurred. This message is printed under the following circumstances: a singularity has occurred, the technique of adding small quantities of species to resolve the singularity has failed, and at least one condensed species is among the species currently being considered in the calculations. The CEA program then removes the first condensed species in the current array and makes another attempt at convergence.

WARNING! POINT (number of point) USES A REDUCED SET OF COMPONENTS. SPECIES CONTAINING THE ELIMINATED COMPONENT ARE OMITTED. IT MAY BE NECESSARY TO RERUN WITH INSERTED CONDENSED SPECIES CONTAINING COMPONENT (name of eliminated component) (EQLBRM)

After a component has been eliminated, it may be impossible to test for the possible presence of other condensed species containing the eliminated component. For this situation, as suggested by the message, it may be desirable to rerun with an insert of the condensed species to be considered.

WARNING!! RESULTS MAY BE WRONG FOR POINT (number) DUE TO LOW MOLE FRACTION OF GASES (value of molar gas fraction) (EQLBRM)

As discussed in section 2.2 of Gordon and McBride (1994), the equation of state for gases is assumed to be correct even when small amounts of condensed species (up to several percent by weight) are present. When the mole fraction of gases is less than 0.0001, the program prints this warning message and continues.

6.3 FROZEN Message

FROZEN DID NOT CONVERGE IN 8 ITERATIONS (FROZEN)

Rocket calculations based on frozen composition during expansion generally require from one to four iterations to reach convergence for each assigned point. We have not yet encountered a problem that required eight iterations. This error message was included primarily as a precaution to avoid infinite cycling of the iteration loop in the event of a machine error. The CEA program continues after printing this message.

6.4 HCALC Messages

COEFFICIENTS FOR (name of reactant) ARE NOT AVAILABLE (HCALC)

Fatal error. Reactant has thermodynamic data for only one temperature. Since shock and detonation problems permit more than one temperature in the temperature schedule, thermodynamic coefficients are needed to calculate thermodynamic properties. Control is returned to the main program, which continues with the next problem, if any.

REACTANT (name of species) NOT FOUND IN *thermo.lib* (HCALC)

Fatal error. Reactant was not found in the thermodynamic library, *thermo.lib*. Check for possible errors in reactant name. If the data are not in the library, the problem may still be run if all necessary information is given in the **reac** dataset. Control is returned to the main program, which continues with the next problem, if any.

REACTANTS MUST BE GASEOUS FOR THIS PROBLEM (HCALC)

Fatal error. Subroutine HCALC is used only for those detonation and shock problems for which reactants must be gaseous. Control is returned to the main program, which continues with the next problem, if any.

6.5 INFREE Messages

FATAL ERROR IN INPUT FORMAT (INFREE)

The CEA program was unable to decipher the line of input preceding this message. If it occurs, control is returned to the main program, which terminates further calculations.

WARNING!! UNACCEPTABLE NUMBER (value of number) (INFREE)

An illegal numerical variable was found. Possibly alphabetical characters were mixed with numbers. The variable is ignored and the program continues.

6.6 INPUT Messages

ERROR IN REACTANTS DATASET (INPUT)

Fatal error. This error, which is described in the printed message preceding this one in the listing, occurred when the CEA program was trying to process data in subroutine REACT. The following error message is also printed. Control is returned to the main program, which continues with the next problem, if any.

FATAL ERROR IN DATASET (INPUT)

Fatal error. This error is described in the printed message preceding this one in the listing.

MOLES AND WEIGHT PERCENTS SHOULD NOT BE MIXED (INPUT)

Fatal error. For each problem, reactant amounts should be given in terms of either all moles (all number of moles, all mole fractions, or all mole percents) or all weights (all weight fractions or all weight percents), but not in both moles and weights. The second INPUT error message is also printed, and control is returned to the main program, which continues with the next problem, if any.

REACTANT AMOUNT MISSING (INPUT)

Fatal error. The amount of a reactant (moles or weight) is missing. The second INPUT error message is also printed, and control is returned to the main program, which continues with the next problem, if any.

REACTANT TEMPERATURE MISSING (INPUT)

Fatal error. A numerical value is not given following a literal that starts with the letter **t** in the **reac** dataset. The second INPUT error message is also printed, and control is returned to the main program, which continues with the next problem, if any.

TYPE OF PROBLEM NOT SPECIFIED (INPUT)

Fatal error. The variable indicating the type of problem in the **prob** dataset was not recognized by the CEA program. The second INPUT error message is also printed, and control is returned to the main program, which continues with the next problem, if any.

UNABLE TO PROCESS EQUIVALENCE RATIO = (number) (INPUT)

Fatal error. The program is unable to convert equivalence ratio to oxidant-to-fuel ratio. Possibly, an oxidant is not labeled as an oxidant or a fuel is not labeled as a fuel. The second INPUT error message is also printed, and control is returned to the main program, which continues with the next problem, if any.

WARNING!! A KEYWORD IS MISSING (INPUT)

Program continues.

WARNING!! DID NOT RECOGNIZE (name of variable) (INPUT)

A literal variable in the dataset just processed was not recognized by the CEA program. The program ignores this variable and continues.

WARNING!! LITERAL EXPECTED FOR (name of variable) (INPUT)

A number was found instead of the literal that was expected for this variable in the **reac** dataset. This value is ignored and the program continues.

WARNING!! (atomic symbol) NOT RECOGNIZED (INPUT)

The program was unable to decipher the exploded chemical formula in the **reac** dataset. The species is ignored and the program continues.

6.7 REACT Messages

AMOUNT MISSING FOR REACTANT NO. (reactant number) (REACT)

Fatal error. The amount of reactant in the **reac** dataset is missing. Control is returned to the main program, which continues with the next problem, if any.

DATA FOR (name of reactant) NOT FOUND IN thermo.lib (REACT)

Fatal error. The CEA program was not able to match the name given in the **reac** dataset with a name from *thermo.lib*. If the exploded chemical formula of a reactant is not included in the dataset or if a required enthalpy or internal energy value is missing, the thermodynamic library *thermo.lib* will be searched for data for that reactant. The error message is printed if the search is unsuccessful. Control is returned to the main program, which continues with the next problem, if any.

(symbol of chemical element) NOT FOUND IN BLOCKDATA (REACT)

Fatal error. The symbol for a chemical element in the exploded formula of a reactant in the **reac** dataset was not found in BLOCKDATA. Control is returned to the main program, which continues with the next problem, if any.

T= (value of temperature) K MORE THAN 10 K FROM (value of temperature) FOR (name of species) (REACT)

Fatal error. For reactants in *thermo.lib*, where there is an assigned enthalpy and corresponding temperature but no thermodynamic coefficients, the temperature given in the **reac** dataset must be within 10 K of the temperature in *thermo.lib*. Control is returned to the main program, which continues with the next problem, if any.

WARNING!! AMOUNT MISSING FOR REACTANT (reactant number). PROGRAM SETS WEIGHT PERCENT = 100. (REACT)

If the problem contains only one fuel, or one oxidant, or one reactant in the **reac** dataset and the amount was not given, the CEA program will automatically set the amount to be 100% and continue.

6.8 ROCKET Messages

FATAL ERROR!! EITHER \dot{m}/a or ac/at MISSING FOR THE f_{ac} PROBLEM (ROCKET)

The f_{ac} option for rocket performance calculations requires either the mass flow rate per unit chamber area \dot{m}/A or the contraction area ratio A_c/A_t to be assigned in the **prob** dataset. If neither one is assigned, this message is printed and the program goes on to the next problem.

INPUT VALUE OF $\dot{m}/a = (\text{value of } \dot{m}/A)$ IS TOO LARGE. GIVES CONTRACTION RATIO ESTIMATE LESS THAN 1 (ROCKET)

Fatal error. In the rocket finite-area-combustor model f_{ac} , an option is provided to assign \dot{m}/A . If this assigned value gives a contraction ratio less than 1, the error message is printed and control is returned to the main program, which continues with the next problem, if any.

WARNING!! AREA RATIO CALCULATION CANNOT BE DONE BECAUSE GAMMAS CALCULATION IMPOSSIBLE (ROCKET)

The iteration procedure for obtaining a pressure ratio corresponding to an assigned area ratio requires a value of γ_s as well as some other parameters (eq. (6.23) of Gordon and McBride, 1994). If a value of γ_s cannot be calculated for this point, the error message is printed and the CEA program proceeds to the next point. The problem can be rerun using estimated pressure ratios to obtain area ratios at or near the desired value.

WARNING!! ASSIGNED $p_i/p_e = (\text{value of assigned } P_i/P_e)$ IS NOT PERMITTED TO BE LESS THAN $P_{inj}/P_c = (\text{value of } P_{inj}/P_c)$. POINT OMITTED (ROCKET)

In a rocket finite-area-combustor model f_{ac} it is not possible for an assigned input value of p_i/p_e to be less than P_{inj}/P_c (the ratio of pressures at the beginning and end of the combustion chamber). If such a value is assigned in the input, this error message is printed, the point is omitted, and the program continues with the next assigned point.

WARNING!! ASSIGNED $sub_{ae}/at = (\text{value of assigned } A_e/A_t)$ IS NOT PERMITTED TO BE GREATER THAN $ac/at = (\text{value of } A_c/A_t)$. POINT OMITTED (ROCKET)

In a rocket finite-area-combustor model f_{ac} , it is physically impossible for a subsonic area ratio to be greater than the contraction ratio. The CEA program omits this incorrectly assigned area ratio and continues.

WARNING!! CALCULATIONS WERE STOPPED BECAUSE NEXT POINT IS MORE THAN 50 K BELOW THE TEMPERATURE RANGE OF A CONDENSED SPECIES (ROCKET)

For frozen composition, calculations a temperature was calculated to be more than 50 K below the temperature range of an included condensed species. Output tables are printed for all previous points and the program continues.

**WARNING!! DID NOT CONVERGE FOR AREA RATIO = (value of area ratio)
(ROCKET)**

The CEA program permits a maximum of 10 iterations to converge to the pressure ratio corresponding to the assigned area ratio. The usual number of iterations required is 1 to 5. The only time the number of iterations has exceeded 10, in our experience, has been for an assigned area ratio very close to 1, such as $1.0 < A_e/A_t < 1.0001$. The reason is that the converged throat conditions do not correspond exactly to an area ratio of 1 (see eq. (6.16) of Gordon and McBride, 1994). If the number of iterations exceeds 10, the point is omitted and the program continues with the next assigned point.

WARNING!! DIFFICULTY IN LOCATING THROAT (ROCKET)

The test for convergence for throat conditions is given in equation (6.16) of Gordon and McBride (1994). If this test is not passed in 23 iterations, this warning message is printed and the program continues with the next point.

WARNING!! DISCONTINUITY AT THE THROAT (ROCKET)

Under some unusual circumstances involving condensed species in the region of the throat, a special technique is used to obtain throat conditions. This technique involves a discontinuous velocity of sound at the throat. Details are given in Gordon (1970).

**WARNING!! FOR FROZEN PERFORMANCE, POINTS WERE OMITTED WHERE
THE ASSIGNED PRESSURE RATIOS WERE LESS THAN THE VALUE AT POINT
n f z = (value of n f z) (ROCKET)**

Pressure ratios may be assigned only downstream of the pressure ratio where freezing is assigned to occur. Pressure ratios not meeting this requirement are omitted, and the calculations continue.

**WARNING!! FOR FROZEN PERFORMANCE, POINTS WERE OMITTED WHERE
THE ASSIGNED SUPERSONIC AREA RATIOS WERE LESS THAN THE VALUE AT
POINT n f z = (value of n f z) (ROCKET)**

Area ratios may be assigned only downstream of the area ratio where freezing occurs. Area ratios not meeting this requirement are omitted, and the calculations continue.

**WARNING!! FOR FROZEN PERFORMANCE, SUBSONIC AREA RATIOS WERE
OMITTED SINCE n f z IS GREATER THAN 1 (ROCKET)**

Area ratios may be assigned only downstream of the area ratio where freezing is assigned to occur. Inasmuch as in this problem freezing is assigned to occur at $n f z > 1$ (the throat or some supersonic point), all subsonic area ratios are omitted and the calculations continue.

WARNING!! FREEZING IS NOT ALLOWED AT A SUBSONIC PRESSURE RATIO FOR n_{fz} GREATER THAN 1. FROZEN PERFORMANCE CALCULATIONS WERE OMITTED (ROCKET)

For $n_{fz} > 1$, throat conditions will be based on equilibrium compositions. For this situation, it is therefore not permitted to assign freezing to occur at a subsonic pressure ratio. Frozen performance is omitted and the program continues.

WARNING!! n_{fz} NOT ALLOWED TO BE > 2 IF THE TOTAL NUMBER OF POINTS IS $>$ (number) (ROCKET)

The CEA program permits freezing at a point greater than 2 if there is only one page of the equilibrium output table. The reason is that a second page wipes out the information from the first page except for the combustion and throat columns. This message is printed when the total number of assigned pressure ratios and area ratios (both subsonic and supersonic) is greater than NCOL (the number of columns in the output listing) minus 2 (the number of columns for combustion and throat). In this situation, frozen performance is omitted and the program continues.

6.9 SEARCH Messages

INSUFFICIENT STORAGE FOR (number of) SPECIES (SEARCH)

Fatal error. This statement shows that for the chemical system under consideration, the program found more possible species in *thermo.lib* than can be accommodated by storages reserved for the thermodynamic data in labeled COMMON /THERM/. This excess number of species is given in this error message. When this situation occurs, the names of the possible species are printed, and control is returned to the main program, which continues with the next problem, if any.

This situation can be resolved in two ways. First, the program can be recompiled with MAXNGC in the parameter statements increased to accommodate the excess species (see section 4.9.1). Secondly, an **omit** dataset can be used to eliminate the required number of excess species.

WARNING!! (name of species) MISSING IN *thermo.lib* FILE (SEARCH)

The species name was listed in the dataset **only**, but the species was not found in *thermo.lib*. The species is ignored and the program continues.

6.10 SHCK Messages

WARNING!! ONLY (NCOL) u_1 OR $mach_1$ VALUES ALLOWED (SHCK)

The number of assigned values of u_1 or $mach_1$ in dataset **prob** exceeded the maximum allowed. This maximum is NCOL (number of columns), which is set in a PARAMETER statement. NCOL is usually 7 or 13 depending on the width of the paper used for printing output. The excess points are ignored and the program continues.

WARNING!! NO CONVERGENCE FOR u_1 = (value of u_1). ANSWERS NOT RELIABLE, SOLUTION MAY NOT EXIST (SHCK)

This message usually occurs when the assigned values of u_1 , T_1 , and P_1 do not have a solution. For example, for example 7 in section 7.5, no solution exists for values of shock u_1 less than approximately 1095 m/s using the current set of thermodynamic data. The message will therefore be printed for this problem for these low values, and the program continues.

WARNING!! TEMPERATURE = (value) IS OUT OF EXTENDED RANGE FOR POINT (value) (SHCK)

Fatal error. This message is printed whenever a converged temperature for a shock problem is higher than the highest T in the temperature range times 1.25 or if the assigned temperature ± 1 is less than the lowest T in the range divided by 1.5. The program prints all the converged values up to this point and continues with the next problem, if any.

6.11 TRANIN Message

WARNING!! MAXIMUM ALLOWED NO. OF SPECIES (number) WAS USED IN TRANSPORT PROPERTY CALCULATIONS FOR POINT (number of point) (TRANIN)

The number of gaseous species used in the thermal transport properties calculations was cut off at the maximum number MAXTR set in a PARAMETER statement. The omitted species are the ones with the smallest mole fractions.

6.12 UTERM Message

ERROR IN PROCESSING *thermo.inp* AT OR NEAR (name of species) (UTERM)

Fatal error. An error occurred in reading or processing the *thermo.inp* file. After the message is printed, the program terminates.

6.13 UTRAN Message

ERROR IN PROCESSING *trans.inp* (UTRAN) (name of 1 or 2 species)

Fatal error. An error occurred in reading or processing the *trans.inp* file. After the message is printed, the program terminates.

Chapter 7

Example Problems

Fourteen example problems are given to illustrate some features of the program. The output for these problems is given in appendix G. Inasmuch as the thermodynamic and thermal transport data are updated periodically, the answers given for these examples may change somewhat from time to time. In the **prob** datasets the case designations were chosen to match the example numbers. Examples 1 and 14 are assigned-temperature and assigned-pressure problems, **tp**; example 2 is an assigned-temperature and assigned-volume (or assigned density) problem, **tv**; three are combustion problems (examples 3 and 5 are for combustion at constant pressure, **hp**, and example 4 is for combustion at constant volume, **uv**); example 6 is a detonation problem, **det**; example 7 is a shock problem, **sh**; and six (examples 8 to 13) are rocket problems, **ro** or **rkt**. These problems were run with NCOL set to 8 (see section 4.9.1).

It would not be practical to illustrate every possible variation of options permitted by the program. However, the example problems were selected to illustrate many of the possible variations and in particular those variations that we feel might often be used. Included in the features illustrated are the following:

1. Specifying proportions of various reactants
 - a. Relative weights of reactants
 - i. Complete information in **reac** dataset: example 5
 - ii. Information in **reac** and **prob** datasets: examples 2 to 4, 6, 8 to 10, 12, and 13
 - b. Relative moles of reactants
 - i. Complete information in **reac** dataset: examples 7, 11, and 14
 - ii. Information in **reac** and **prob** datasets: example 1
 - c. Type of information provided in **prob** dataset (in addition to that given in **reac** dataset):
 - i. *o/f*: examples 3, 4, 8 to 10, and 12
 - ii. Chemical equivalence ratio *r*: examples 1 and 6
 - iii. Fuel-air equivalence ratio ϕ : example 2
 - iv. Percent fuel by weight, *%fuel*: example 13

2. Exploded formula
 - a. Obtained directly from *thermo.lib*: 1 to 4, 5 (partly), and 6 to 13
 - b. Specified in **reac** dataset: 5 (partly) and 14
3. Specifying enthalpies or internal energies
 - a. In **reac** dataset: example 5 (partly)
 - b. In **prob** dataset: example 4
 - c. Automatically calculated by program from data in *thermo.lib*: examples 3, 5 (partly), and 6 to 13
 - d. Not needed: examples 1, 2, and 14
4. Pressure units
 - a. atm: examples 1 and 14
 - b. psia: examples 5 and 11 to 13
 - c. mm Hg: example 7
 - d. bar: examples 3, 6, and 8 to 10
 - e. Not required: examples 2 and 4
5. **inse**: example 13
6. **omit**: examples 3 to 5
7. **only**: examples 1 and 2
8. **trace** (composition in floating-point format): examples 3, 4, and 13
9. Considering ions: example 11
10. Propellant density: example 12
11. Output units
 - a. In SI units: examples 3, 4, 7 to 12, and 14
 - b. Not in SI units: examples 1, 2, 5, 6, and 13
12. Output composition units
 - a. Mass fractions: example 12
 - b. Mole fractions: all examples except 12
13. Transport properties included: examples 2, 6, and 11
14. Dump for plotting: example 12
15. Special thermodynamic derivatives: example 13

16. Two definitions of molecular weight: examples 5, 13, and 14 (discussed in section 7.10)
17. Internal thermodynamic consistency: examples 1 to 4

The following discussion of the 14 example cases includes the features outlined above plus some additional features of the program.

7.1 Examples 1 and 2

Examples 1 and 2 are used, among other things, to demonstrate internal consistency in the CEA program for assigned-temperature and assigned-pressure problems, τ_p ; and assigned-temperature and assigned-volume problems, τ_v . The same reactants are used in the two examples, and part of the output from example 1 is used as input for example 2.

7.1.1 Example 1

Example 1 is an example of a τ_p problem. Properties will be calculated for all combinations of temperatures and pressures specified. In this example, two temperatures (3000 and 2000 K) and three pressures (1, 0.1, and 0.01 atm) are specified, for a total of six combinations. Each of these six combinations will be run for two equivalence ratios ($r=1$ and 1.5). The exploded formulas for the fuel (H₂) and oxidant (Air) are obtained automatically from *thermo.lib* (see section 2.3.8). Enthalpies of the reactants are not needed for a τ_p problem.

7.1.2 Example 2

Example 2 is an example of an assigned-temperature and assigned-volume (or -density) problem, τ_v . As previously stated, examples 1 and 2 are used to demonstrate internal consistency in the CEA program for τ_p and τ_v problems. The combustion mixture densities taken from example 1 output for the equivalence ratio of 1 and for 3000 K were used as part of the input for example 2. It may be seen in the output of example 2 that the pressures of 1, 0.1, and 0.01 atm, used as input in example 1, are reproduced exactly. The equivalence ratio was specified here in terms of ϕ rather than r as in example 1. For stoichiometric conditions, the two definitions give equal values (see discussion in chapter 9 of Gordon and McBride, 1994).

Example 2 also includes thermal transport properties (τ_{ran} in the **outp** dataset). As discussed in section 5.2.3 of Gordon and McBride (1994), the specific heat for thermal transport property calculations $c_{p,equl}$ is calculated by a different method from the more general specific heat $c_{p,eq}$. When no condensed species are present, the two methods should give the same numerical values of specific heat, except possibly for rounding errors. This agreement, which occurs here as well as in examples 6 and 11, confirms the accuracy of the calculations.

7.2 Examples 3 and 4

Examples 3 and 4 illustrate, among other things, internal consistency in combustion problems (example 3 for combustion at constant pressure, hp; and example 4 for combustion at constant volume, uv). The same propellants are used in the two examples, and part of the output of example 3 is used as input for example 4.

7.2.1 Example 3

Example 3 is an example of a combustion problem at constant pressure, hp. Three pressures were selected: 1, 10, and 100 bars. Reactant enthalpies and exploded formulas for all reactants in this problem will be obtained automatically from *thermo.lib*. Note that the fuel and oxidant do not have to be at the same initial temperature. In this problem, the air is preheated to 700 K. The results of the enthalpy calculation for the oxidants may be seen in reactants data in the output.

This example also illustrates the option of listing compositions whose amounts are smaller than those listed in the fixed-point output (i.e., smaller than 0.000005). This is accomplished by using the `trace` option in the `outp` dataset. In this example, `trace=1.E-15`.

Some of the output of this case will be used as input for example 4.

7.2.2 Example 4

Example 4 illustrates combustion at constant volume (or density), uv. This type of problem generally requires as input the internal energies of the reactants at some initial temperature as well as the assigned volume (or density). In this case, we are using as input the density and internal energy of the combustion mixture resulting from the first point of example 3. The reason for this selection is to verify the internal consistency and accuracy of the calculation procedures. Verification will be accomplished if the same combustion temperature and pressure are obtained as in example 3. From example 3, the value for density is 14.428 kg/m^3 . The input for internal energy is required to be in the form of u/R , where u is internal energy and R is the universal gas constant in consistent units. From example 3, output $u=-375.27 \text{ kJ/kg}$ is obtained. This gives $u/R=-375.27/8.31451=-45.1343 \text{ (kg-mol)(K)/kg}$. As expected, the resulting combustion temperature of 2419.33 K and combustion pressure of 100 bars match those of example 3 exactly.

7.3 Example 5

Example 5 is for a typical solid propellant. The relative amounts of reactants are given in weight percents. Unless an `inse` dataset is present, the CEA program initially considers only gaseous combustion products. An initial combustion temperature of 2223.217 K was reached in 15 iterations. This information may be seen in the output under the heading POINT ITN. The program then checks for the possibility that condensed species should have been considered. In this example, it determined that the solid phase $\text{Al}_2\text{O}_3(\text{a})$ should be added. (The solid phase exists below the melting point of 2327 K.) With $\text{Al}_2\text{O}_3(\text{a})$ added, the temperature converged in seven iterations to 2800.188 K. The program now checks for the appropriate phase and determines that the phase at this temperature is liquid and makes the appropriate switch. This may be seen by the message PHASE CHANGE, REPLACE AL2O3(a) WITH AL2O3(L). The next convergence took just two iterations and gave a final combustion temperature of 2724.464 K.

Had the keyword **inse** followed by AL2O3(L) been used in the input, convergence would have been reached in 15 iterations rather than 24 iterations needed with no **inse** being used. However, the use of **inse** often implies some prior knowledge of which condensed species or phases exist. If one is starting a new problem, it may be better to just let the program figure this out rather than inserting a possibly incorrect condensed species that the program must then remove. The **inse** option may be used only for the first point. After the first point the insertions and removals of condensed phases are all handled automatically by the program.

In some situations, however, the keyword **inse** is required, as in a combustion problem when temperature is driven down too low without the appropriate condensed species present. When this happens, an error message will be printed.

7.4 Example 6

Example 6 is an example of a detonation problem, **det**. Calculations will be made for all combinations of pressures and temperatures specified. In this example, two pressures (1 and 20 bars) and two temperatures (298.15 and 500 K) have been scheduled. When temperatures are specified in the **prob** dataset, enthalpies for the **det** problem are calculated automatically by the program for the assigned temperatures. For this situation, this implies that only those gaseous species whose thermodynamic data are in the *thermo.lib* file (such as H₂ and O₂ in this example) may be considered as possible reactants. This example also includes thermal transport property calculations (see discussion in section 7.1.2).

7.5 Example 7

Example 7 is an example of a shock problem, **sh**. The input permits a schedule of either velocities **u1** or Mach numbers **mach1**, but not both in the same input dataset. For this example, a set of velocities was assigned. Only the incident shock conditions were calculated. To obtain reflected shock conditions, the **prob** dataset would have required **refleq** for reflected shocks based on equilibrium incident conditions and/or **reflfr** for reflected shocks based on frozen incident conditions. The message that starts with WARNING!! NO CONVERGENCE FOR **u1=1000.0** usually indicates that no solution exists for the assigned condition.

7.6 Examples 8, 9, and 10

Examples 8 to 10 illustrate some similarities and differences in rocket performance calculations for the two models of an infinite-area combustor, **iac**, and a finite-area combustor, **fac**. All three examples are for the same propellant, chamber pressure, o/f ratio, pressure ratios, and area ratios. Example 8 is for the **iac** assumption. Inasmuch as the default is for the **iac** assumption, this information is not required in the **prob** dataset. Examples 9 and 10, by contrast, are for the **fac** assumption, and this needs to be specified in the **prob** dataset. A subsonic area ratio of 1.58 (**subar=1.58**) was assigned in order to compare the results with those obtained when using the same assigned value of A_c/A_t (the contraction ratio assigned for examples 9 and 10). The outputs for examples 8 to 10 will be compared in the discussion of examples 9 and 10.

7.6.1 Example 8

Example 8 illustrates a typical rocket performance problem based on the model of an infinite-area combustor, **i ac**. Note that there are nine output points (columns): the chamber, the throat, three pressure ratios, one subsonic area ratio, and three supersonic area ratios. Since NCOL (number of columns or points) was set to 8 in the program, output for the last supersonic area ratio was printed on the second page along with the chamber and throat, which are repeated for convenience.

7.6.2 Example 9

Examples 9 and 10 are for the **f ac** model. Two options are permitted with this model. The first option, assigning the contraction ratio A_c/A_t (**acat**) is illustrated in example 9. The second option, assigning the mass flow rate per unit area \dot{m}/A_c (**ma**) is illustrated in example 10. The results of example 9 for an assigned value of $A_c/A_t=1.58$ were used to calculate a value of $\dot{m}/A_c=1333.9$. This value was used as input in example 10 in order to verify the consistency of the results.

7.6.3 Example 10

As mentioned in the previous section, example 10 is identical to example 9 except for using a value of \dot{m}/A_c instead of A_c/A_t as input. The input value of $ma=1333.9$ for example 10 was calculated from the results of example 9. As expected, the value of $A_c/A_t=1.5800$ calculated in example 10 matches the example 9 input value of 1.58. This result confirms the accuracy and consistency of the calculations and iteration procedures.

As pointed out in Gordon (1988), the calculated values of specific impulse for the **f ac** and **i ac** rocket models are extremely close for the same assigned area ratios. For example, at an area ratio of 75, the **i ac** rocket model in example 8 gives a specific impulse of 4399.7 m/s, which compares closely with 4399.0 m/s obtained for the **f ac** model of examples 9 and 10. The difference is only 0.02%.

7.7 Example 11

Example 11 illustrates including ions as possible combustion species (the option **ions** is part of the **prob** dataset). At the high combustion temperature of 5686 K, about 1.5% of the species are the result of ionization. This example also shows that it is possible to assign a schedule of points for expansion in a rocket that includes a mixture of pressure ratios, subsonic area ratios, and supersonic area ratios. Note in the output that two area ratios are assigned the value of 10. Their corresponding Mach numbers indicate which is subsonic and which is supersonic. Example 11 also includes thermal transport property calculations (see discussion in section 7.1.2).

7.8 Example 12

Example 12 is another example of rocket performance. Several options are illustrated in this example: the `nfz` option for freezing composition, the calculation of reactant density, the option of obtaining compositions as mass fractions rather than mole fractions, and the `plot` option for obtaining an output dump for plotting purposes. By setting `nfz=2`, frozen composition rocket performance calculations are based on compositions frozen at the second point. By including densities of all individual reactants (`rho` in the `reac` dataset), the program will calculate the reactant mixture density. By including `massf` in the `outp` dataset, compositions are given as mass fractions. By including `plot` in the `outp` dataset, a dump of values for the parameters following `plot` is generated in the file *(input suffix).plt*. (see section 2.5.4).

7.9 Example 13

Example 13 illustrates some unusual values of thermodynamic derivatives that occur when two condensed phases are present simultaneously. The appropriate equation for $\gamma_{s,T}$, which is needed to calculate velocity of sound under these conditions, is equation (3.9) in Gordon and McBride (1994). As may be seen in the output of example 13 for the second and third points, $\gamma_{s,T}$ equals 0.9979 and 0.9974, respectively. This topic is covered more completely in Gordon (1970).

7.10 Example 14

Example 14 was chosen for three reasons. The first was to check out the size of the error caused by assuming zero volume of condensed species in the equation of state (eq. (2.1a) in section 2.2 of Gordon and McBride, 1994). The second was to look at an example of the two definitions of molecular weight given as equations (2.3b) and (2.4a) in Gordon and McBride (1994). The third reason was to illustrate debug output (see section 3.4 for further discussion). The reactants are hydrogen and oxygen. This example is a `tp` problem where the pressure (0.05 atm), the schedule of temperatures (1000, 500, 350, 305, 304.3, 304.2, 304, and 300 K), and the relative number of moles of hydrogen to oxygen were chosen to produce a large calculated mole fraction of liquid water for some conditions.

For $T=304$ K the mole fraction of liquid water is 0.24681. Using the density 0.99539 g/cm^3 at this temperature (Lide, 1992–1993), the volume of water in 1 mole of mixture is calculated to be 4.5 cm^3 , in contrast to $375\,900 \text{ cm}^3$ for the gases. Therefore, even though the mole fraction of the condensed species is about 25%, the relative volume of the condensed phase is only 0.001%. Thus, in this example, the assumption of negligible volume for condensed species that is incorporated into the equation of state (eqs. (2.1a) and (2.1b) in Gordon and McBride, 1994) is valid for most practical purposes. For other problems with higher pressures than in this case, the relative volume of the condensed species will be generally be greater than here but less than 0.1%.

For those problems with combustion products containing condensed phases, two values of molecular weight are given in the output (see final table in example 14, appendix G). These values are based on definitions given in section 2.2 of Gordon and McBride (1994). Note that in the present example the product compositions remain constant if all phases of water are combined. It is therefore to be expected that the molecular weights of the mixture would be the same for all points. This is indeed the case for the molecular weight MW , where the value for all points is 19.287. However, the molecular weight M increases for those points with increasing amounts of liquid water, consistent with the assumptions incorporated in the equation of state (eq. (2.1) in Gordon and McBride, 1994). The molecular weight M is obtained by means of equations (2.3a) or (2.3b), MW is given by equation (2.4a), and the relationship between M and MW is given by equation (2.4b) in Gordon and McBride (1994). For the $T=304$ K point equation (2.4b) gives $MW=25.607 \times 0.75319=19.287$, which matches exactly the molecular weight of 19.287 given in the table.

Lewis Research Center,
National Aeronautics and Space Administration,
Cleveland, Ohio, January 28, 1996.

Appendix A

Format for Thermodynamic Data

The library of thermodynamic data contains data for both reaction products and reactants. All reaction products and some reactants are in the nine-constant functional form discussed in section 4.2 of Gordon and McBride (1994). The format for these data is given here. Thermodynamic data are provided with the program on a separate file, *thermo.inp*. Sections 2.8 and 5.24 discuss the processing of the *thermo.inp* data and the storing of the processed data in *thermo.lib* for subsequent use in the CEA program. Names of species contained in *thermo.inp* are listed in appendix B.

The general format is given in table A1. This format is applicable for all gaseous species and for those condensed species whose data extend over a temperature range. For those condensed species with data given at only one temperature, the format is somewhat different. On record 2, instead of the last number being a heat of formation, it is an assigned enthalpy. (Note that if the temperature is 298.15 K, the heat of formation and the assigned enthalpy are equivalent.) The first number in record 2 (number of temperature intervals) is always zero. On record 3, only one number is given, the temperature of the assigned enthalpy on record 2. Two examples are given. Example A1, for chlorine gas, illustrates the general format. Example A2, for liquid acetylene, illustrates the format for a condensed species with data given at only one temperature. The general equations for dimensionless heat capacity, enthalpy, and entropy (eqs. (4.6) to (4.8) from Gordon and McBride, 1994) are repeated for convenience.

TABLE A.1.—GENERAL FORMAT FOR NINE-CONSTANT FUNCTIONAL FORM

Record	Constants	Format	Columns
1	Species name or formula	A24	1–24
	Comments (data source)	A56	25–80
2	Number of T intervals	I2	2
	Optional identification code	A6	4–9
	Chemical formulas, symbols, and numbers	5(A2,F6.2)	11–50
	Zero for gas and nonzero for condensed phases	I1	52
	Molecular weight	F13.5	53–65
	Heat of formation at 298.15 K, J/mol	F13.5	66–80
3	Temperature range	2F10.3	2–21
	Number of coefficients for $C_p^\circ R$	I1	23
	T exponents in empirical equation for $C_p^\circ R$	8F5.1	24–63
	$\{H^\circ(298.15) - H^\circ(0)\}$, J/mol	F15.3	66–80
4	First five coefficients for $C_p^\circ R$	5D16.8	1–80
5	Last three coefficients for $C_p^\circ R$	3D16.8	1–48
	Integration constants b_1 and b_2	2D16.8	49–80
----	Repeat 3, 4, and 5 for each interval	-----	-----

Example A.1:

```

CL2          Chlorine gas. TPIS 1989, v1, pt2, p88.
2 tpis89 CL 2.00  0.00  0.00  0.00  0.00  0  70.90540  0.000
  200.000 1000.000 7 -2.0 -1.0  0.0  1.0  2.0  3.0  4.0  0.0  9181.110
  3.46281724D+04 -5.54712949D+02 6.20759103D+00 -2.98963673D-03 3.17303416D-06
-1.79363467D-09 4.26005863D-13 0.00000000D+00 1.53407075D+03 -9.43835303D+00
  1000.000 6000.000 7 -2.0 -1.0  0.0  1.0  2.0  3.0  4.0  0.0  9181.110
  6.09256675D+06 -1.94962688D+04 2.85453491D+01 -1.44996828D-02 4.46388943D-06
-6.35852403D-10 3.32735931D-14 0.00000000D+00 1.21211722D+05 -1.69077832D+02
  
```

Empirical equations for example A.1:

$$\text{Heat capacity: } \frac{C_p^o}{R} = a_1 T^{-2} + a_2 T^{-1} + a_3 + a_4 T + a_5 T^2 + a_6 T^3 + a_7 T^4$$

$$\text{Enthalpy: } \frac{H^o(T)}{RT} = -a_1 T^{-2} + a_2 T^{-1} \ln T + a_3 + a_4 \frac{T}{2} + a_5 \frac{T^2}{3} + a_6 \frac{T^3}{4} + a_7 \frac{T^4}{5} + \frac{b_1}{T}$$

$$\text{Entropy: } \frac{S^o(T)}{R} = -a_1 \frac{T^{-2}}{2} - a_2 T^{-1} + a_3 \ln T + a_4 T + a_5 \frac{T^2}{2} + a_6 \frac{T^3}{3} + a_7 \frac{T^4}{4} + b_2$$

Example A.2:

```

C2H2(L), acetylene  Acetylene. JANAF Prop. Ser. E, 1/67. TRC a-3000, 10/86.
0 1 3/95 C 2.00H 2.00  0.00  0.00  0.00  1  26.03788  207599.000
  192.35
  
```

Appendix B

Names of Species in Thermodynamic Data File (*thermo.inp*)

The *thermo.inp* file is arranged with data for the products listed first, followed by data for the reactants. Among the products, all gas-phase species data are listed first, followed by condensed-phase species data (liquid and/or solid). The names of gas-phase products are listed in table B.1; the names of condensed-phase products are listed in table B.2. No subscripts are used and no phase is indicated for the gas phase. That is, O2 in *thermo.inp* is gas-phase oxygen, O₂(g), and O2(L) is liquid-phase oxygen, O₂(l). An upper case "L" is used to designate the liquid phase to avoid confusion between the lower case "l" and the number "1." Most of the reactant species are cryogenic fuels or oxidants. Reactant names are listed in table B.3. Species that may be considered as either products or reactants (such as H₂(g), CH₄(g), or O₂(g) and listed as H2, CH4, and O2) are generally included with the products. Occasionally, additional information is added after the chemical formula for clarification. For example, two names start with C4H10(L). One is followed by *n*-butan to indicate normal butane; the other is followed by isobuta to indicate isobutane. (A maximum of 15 characters is allowed for a name.)

As discussed in section 2.3.2, in order for the CEA program to use the data in *thermo.inp* for reactants, the names used in the **reac** dataset must match the names in the *thermo.inp* file exactly. The search for a reactant name starts at the beginning of the file, first with gaseous products, then with condensed products, and finally with reactants.

A complete documentation of references for the thermodynamic data selected for products was not available at the time of publication of this report. Some of the references are given in McBride et al. (1993). Data for the reactants are given in tables C.1 and C.2. (References for the data in table C.1 are given in table D.1.) At the time of publication of this report, the approximate number of species in the *thermo.inp* file was 1340 reaction products and 60 reactants. However, data for species are constantly being added to the file, so that the data and the total number of species keep changing.

TABLE B.1.—NAMES OF GAS-PHASE PRODUCTS IN *thermo.inp*

e-	B-	BeF2	CF3Br
AL	BCL	BeH	CF3CL
AL+	BCL+	BeH+	CF4
AL-	BCLF	BeH2	CH
ALBO2	BCL2	BeI	CH+
ALBr	BCL2+	BeI2	CHBr3
ALBr3	BCL2-	BeN	CHCL
ALC	BCL3	BeO	CHCLBr2
ALCL	BF	BeOH	CHCL2
ALCL+	BF2	BeOH+	CHCL2Br
ALCLF	BF2+	BeO2H2	CHCL3
ALCLF+	BF2-	BeS	CHF
ALCLF2	BF3	Be2O	CHFBr2
ALCL2	BH	Be2OF2	CHFCL
ALCL2+	BHF2	Be2O2	CHFCLBr
ALCL2-	BH2	Be3O3	CHFCL2
ALCL2F	BH3	Be4O4	CHF2
ALCL3	BN	Be5O5	CHF2Br
ALF	BO	Be6O6	CHF2CL
ALF+	BOCL	Br	CHF3
ALF2	BOF	BrCL	CH2
ALF2+	BOF2	BrF	CH2Br2
ALF2-	BO2	BrF3	CH2CL
ALF2O	BO2-	BrF5	CH2CLBr
ALF2O-	BS	BrO	CH2CL2
ALF3	B2	Br2	CH2F
ALF4-	B2H6	C	CH2FBr
ALH	B2O	C+	CH2FC1
ALI	B2O2	C-	CH2F2
ALI3	B2O3	CBr	CH3
ALN	B3O3CL3	CBr2	CH3Br
ALO	B3O3F3	CBr3	CH3CL
ALO+	B3O3H3	CBr4	CH3F
ALO-	Ba	CCL	CH2OH
ALOCL	BaBr	CCLBr3	CH3O
ALOF	BaBr2	CCL2	CH4
ALOH	BaCL	CCL2Br2	CH3OH
ALOH+	BaCL2	CCL3	CI
ALOH-	BaF	CCL3Br	CN
ALO2	BaF+	CCL4	CN+
ALO2-	BaF2	CF	CN-
ALO2H	BaOH	CF+	CNN
ALS	BaOH+	CFBr3	CO
AL2	BaO2H2	CFCL	CO+
AL2Br6	BaS	CFCLBr2	COCL
AL2CL6	Be	CFCL2	COCL2
AL2F6	Be+	CFCL2Br	COF
AL2I6	Be++	CFCL3	COFCL
AL2O	BeBO2	CF2	COF2
AL2O+	BeBr	CF2+	COHCL
AL2O2	BeBr2	CF2Br2	COHF
AL2O2+	BeCL	CF2CL	COS
Ar	BeCL+	CF2CLBr	CO2
Ar+	BeCLF	CF2CL2	CO2+
B	BeCL2	CF3	COOH
B+	BeF	CF3+	CP

TABLE B.1.—Continued.

CS	C3H5, allyl	C7H15, n-heptyl	Cs2CL2
CS2	C3H6, propylene	C7H16, 2-methylh	Cs2F2
C2	C3H6, cyclo-	C7H16, n-heptane	Cs2O
C2+	C3H6O, propyle-o	C8H8, styrene	Cs2O2H2
C2-	C3H7, n-propyl	C8H10, ethylbenz	Cs2SO4
C2CL	C3H7, i-propyl	C8H16, 1-octene	Cu
C2CL2	C3H8	C8H17, n-octyl	Cu+
C2CL3	C3H8O, 1propanol	C8H18, n-octane	CuCL
C2CL4	C3H8O, 2propanol	C8H18, isooctane	CuF
C2CL6	C3O2	C9H19, n-nonyl	CuF2
C2F	C4	C10H8, naphthale	CuO
C2FCL	C4H2	C10H21, n-decyl	Cu2
C2FCL3	C4H4, 1, 3-cyclo-	C12H9, o-bipheny	Cu3CL3
C2F2	C4H6, butadiene	C12D9, o-bipheny	D
C2F2CL2	C4H6, 1-butyne	C12H10, biphenyl	D+
C2F3	C4H6, 2-butyne	C12D10, biphenyl	D-
C2F3CL	C4H6, cyclo-	Ca	DBr
C2F4	C4H8, 1-butene	Ca+	DCL
C2F6	C4H8, cis2-buten	CaBr	DF
C2H	C4H8, tr2-butene	CaBr2	DOCL
C2HCL	C4H8, isobutene	CaCL	DO2
C2HCL3	C4H8, cyclo-	CaCL2	DO2-
C2HF	(CH3COOH) 2	CaF	D2
C2HFCL2	C4H9, n-butyl	CaF2	D2+
C2HF2CL	C4H9, i-butyl	CaI	D2-
C2HF3	C4H9, s-butyl	CaI2	D2O
CHCO, ketyl	C4H9, t-butyl	CaO	D2O2
C2H2, vinylidene	C4H10, isobutane	CaOH	D2S
C2H2, acetylene	C4H10, n-butane	CaOH+	F
C2H2CL2	C4N2	CaO2H2	F+
C2H2FCL	C5	CaS	F-
C2H2F2	C5H6, 1, 3cyclo-	Ca2	FCN
CH2CO, ketene	C5H8, cyclo-	CL	FO
C2H3, vinyl	C5H10, 1-pentene	CL+	FO2
C2H3CL	C5H10, cyclo-	CL-	F2
C2H3F	C5H11, pentyl	CLCN	F2O
CH3CN	C5H11, t-pentyl	CLF	FS2F, fluorodisu
CH3CO, acetyl	C5H12, n-pentane	CLF3	Fe
C2H4	C5H12, i-pentane	CLF5	Fe+
C2H4O, ethylen-o	CH3C (CH3) 2CH3	CLO	Fe-
CH3CHO, ethanal	C6H2	CLO2	FeC5O5
CH3COOH	C6H5, phenyl	CL2	FeCL
C2H5	C6D5, phenyl	CL2O	FeCL2
C2H6	C6H5O, phenoxy	Cr	FeCL3
CH3N2CH3	C6H6	CrN	FeO
C2H5OH	C6D6	CrO	Fe (OH) 2
CH3OCH3	C6H5OH, phenol	CrO2	Fe2CL4
CCN	C6H10, cyclo-	CrO3	Fe2CL6
CNC	C6H12, 1-hexene	Cs	GeBr
C2N2	C6H12, cyclo-	Cs+	GeBr2
C2O	C6H13, n-hexyl	CsCL	GeBr3
C3	C6H14, n-hexane	CsF	GeBr4
C3H3, propargyl	C7H7, benzyl	CsO	GeCL
C3H4, allene	C7H8	CsOH	GeCL2
C3H4, propyne	C7H8O, cresol-mx	CsOH+	GeCL3
C3H4, cyclo-	C7H14, 1-heptene	Cs2	GeCL4

TABLE B.1.—Continued.

GeF	H3F3	Li2SO4	NO2-
GeF2	H3O+	Li3CL3	NO2CL
GeF3	(HCOOH)2	Li3F3	NO2F
GeF4	H4F4	Mg	NO3
GeI	H5F5	Mg+	NO3-
GeO	H6F6	MgBr	NO3F
GeO2	H7F7	MgBr2	N2
GeS	He	MgCL	N2+
GeS2	He+	MgCL+	N2-
Ge2	Hg	MgCLF	NCN
H	HgBr2	MgCL2	cis-N2D2
H+	I	MgF	N2F2
H-	IF5	MgF+	N2F4
HALO	IF7	MgF2	N2H2
HBO	I2	MgF2+	NH2NO2
HBO+	K	MgH	N2H4
HBO-	K+	MgI	N2O
HBO2	KBO2	MgI2	N2O+
HBS	KCN	MgN	N2O3
HBS+	KCL	MgO	N2O4
HBr	KF	MgOH	N2O5
HCN	KF2-	MgOH+	N3
HCO	KH	MgO2H2	N3H
HCO+	KO	MgS	Na
HCCN	KO-	Mg2	Na+
HCL	KOH	Mg2F4	NaALF4
HD	KOH+	MoO3	NaBO2
HD+	K2	Mo2O6	NaBr
HD-	K2C2N2	Mo3O9	NaCN
HDO	K2CL2	Mo4O12	NaCL
HDO2	K2F2	Mo5O15	NaF
HF	K2O2H2	N	NaF2-
HI	K2SO4	N+	NaH
HNC	Kr	N-	NaI
HNCO	Kr+	NCO	NaO
HNO	Li	ND	NaO-
HNO2	Li+	ND2	NaOH
HNO3	LiALF4	ND3	NaOH+
HOCL	LiBO2	NF	Na2
HOF	LiCL	NF2	Na2C2N2
HO2	LiF	NF3	Na2CL2
HO2-	LiFO	NH	Na2F2
HPO	LiF2-	NH+	Na2O
HSO3F	LiH	NHF	Na2O2H2
H2	LiN	NHF2	Na2SO4
H2+	LiO	NH2	Nb
H2-	LiO-	NH2F	NbO
HCHO, formaldehy	LiOH	NH3	NbO2
HCOOH	LiOH+	NH2OH	Ne
H2F2	LiON	NH4+	Ne+
H2O	Li2	NO	Ni
H2O+	Li2CL2	NO+	NiCL
H2O2	Li2F2	NOCL	NiCL2
H2S	Li2O	NOF	NiO
H2SO4	Li2O2	NOF3	NiS
H3B3O6	Li2O2H2	NO2	O

TABLE B.1.—Concluded.

O+	PbBr	SO ₂ F ₂	Si ₂
O-	PbBr ₂	SO ₃	Si ₂ C
OD	PbBr ₃	S ₂	Si ₂ N
OD-	PbBr ₄	S ₂ -	Si ₃
OH	PbCL+	S ₂ F ₂ ,thiothiony	SnBr ₃
OH+	PbCL ₂	S ₂ O	SnBr ₄
OH-	PbCL ₂ +	S ₃	SnCL ₂
O ₂	PbCL ₃	S ₄	SnCL ₃
O ₂ +	PbCL ₄	S ₅	SnCL ₄
O ₂ -	PbF	S ₆	SnF ₂
O ₃	PbF ₂	S ₇	SnF ₃
P	PbF ₃	S ₈	SnF ₄
P+	PbF ₄	Si	SnO ₂
PCL	PbI	Si+	SnS ₂
PCL ₂	PbI ₂	SiBr	Sr
PCL ₂ -	PbI ₃	SiBr ₂	SrBr
PCL ₃	PbI ₄	SiBr ₃	SrCL
PCL ₅	PbO	SiBr ₄	SrCL ₂
PF	PbO ₂	SiC	SrF
PF+	PbS	SiC ₂	SrF+
PF-	PbS ₂	SiC ₄ H ₁₂	SrF ₂
PFCL	Pb ₂	SiCL	SrI ₂
PFCL-	S	SiCL ₂	SrO
PFCL ₂	S+	SiCL ₃	SrOH
PFCL ₄	S-	SiCL ₄	SrOH+
PF ₂	SCL	SiF	SrO ₂ H ₂
PF ₂ -	SCL ₂	SiFCL	SrS
PF ₂ CL	SCL ₂ +	SiF ₂	Ta
PF ₂ CL ₃	SD	SiF ₃	Ta+
PF ₃	SF	SiF ₄	TaO
PF ₃ CL ₂	SF+	SiH	TaO ₂
PF ₄ CL	SF-	SiH+	Ti
PF ₅	SF ₂	SiHBr ₃	Ti+
PH	SF ₂ +	SiHCL	Ti-
PH ₂	SF ₂ -	SiHCL ₃	TiCL
PH ₂ -	SF ₃	SiHF	TiCL ₂
PH ₃	SF ₃ +	SiHF ₃	TiCL ₃
PN	SF ₃ -	SiHI ₃	TiCL ₄
PO	SF ₄	SiH ₂	TiO
PO-	SF ₄ +	SiH ₂ Br ₂	TiOCL
POCL ₃	SF ₄ -	SiH ₂ CL ₂	TiOCL ₂
POFCL ₂	SF ₅	SiH ₂ F ₂	TiO ₂
POF ₂ CL	SF ₅ +	SiH ₂ I ₂	V
POF ₃	SF ₅ -	SiH ₃	VCL ₄
PO ₂	SF ₆	SiH ₃ Br	VN
PO ₂ -	SF ₆ -	SiH ₃ CL	VO
PS	SH	SiH ₃ F	VO ₂
P ₂	SH-	SiH ₃ I	Xe
P ₂ O ₃	SN	SiH ₄	Xe+
P ₂ O ₄	SO	SiI	Zn
P ₂ O ₅	SO-	SiI ₂	Zn+
P ₃	SOF ₂	SiN	Zn-
P ₄	SO ₂	SiO	Zr
P ₄ O ₆	SO ₂ -	SiO ₂	ZrN
P ₄ O ₁₀	SO ₂ CLF	SiS	ZrO
Pb	SO ₂ CL ₂	SiS ₂	ZrO ₂

TABLE B.2.—NAMES OF CONDENSED-PHASE PRODUCTS IN *thermo.inp*

Ag(cr)	BeS(s)	CuO(s)	KO2(s)
Ag(L)	Be2C(s)	CuO2H2(s)	K2CO3(s)
Al(cr)	Be2C(L)	CuSO4(s)	K2CO3(L)
Al(L)	Br2(cr)	Cu2O(s)	K2O(s)
AlBr3(s)	Br2(L)	Cu2O(L)	K2O2(s)
AlBr3(L)	C(gr)	Cu2O5S(s)	K2S(1)
AlCL3(s)	Ca(a)	Fe(a)	K2S(2)
AlCL3(L)	Ca(b)	Fe(a)	K2S(3)
ALF3(a)	Ca(L)	Fe(c)	K2S(L)
ALF3(b)	CaBr2(s)	Fe(d)	K2SO4(a)
ALF3(L)	CaBr2(L)	Fe(L)	K2SO4(b)
ALI3(s)	CaCO3(caL)	FeC5O5(L)	K2SO4(L)
ALI3(L)	CaCL2(s)	FeCL2(s)	Li(cr)
ALN(s)	CaCL2(L)	FeCL2(L)	Li(L)
AL2O3(a)	CaF2(a)	FeCL3(s)	LiALO2(s)
AL2O3(L)	CaF2(b)	FeCL3(L)	LiALO2(L)
AL2SiO5(an)	CaF2(L)	FeO(s)	LiCL(s)
AL6Si2O13(s)	CaO(s)	FeO(L)	LiCL(L)
B(b)	CaO(L)	Fe(OH)2(s)	LiF(s)
B(L)	CaO2H2(s)	Fe(OH)3(s)	LiF(L)
BN(s)	CaS(s)	FeS(a)	LiH(s)
B2O3(L)	CaSO4(s)	FeS(b)	LiH(L)
B3O3H3(cr)	Cd(cr)	FeS(c)	LiOH(s)
Ba(cr)	Cd(L)	FeS(L)	LiOH(L)
Ba(L)	Co(a)	FeSO4(s)	Li2O(s)
BaBr2(s)	Co(b)	FeS2(s)	Li2O(L)
BaBr2(L)	Co(b)	Fe2O3(s)	Li2SO4(a)
BaCL2(a)	Co(L)	Fe2S3O12(s)	Li2SO4(b)
BaCL2(b)	Cr(cr)	Fe3O4(s)	Li2SO4(L)
BaCL2(L)	Cr(cr)	Ge(cr)	Li3N(s)
BaF2(a)	Cr(cr)	Ge(L)	Mg(cr)
BaF2(b, c)	Cr(L)	H2O(s)	Mg(L)
BaF2(L)	CrN(s)	H2O(L)	MgAL2O4(s)
BaO(s)	Cr2N(s)	H2SO4(L)	MgAL2O4(L)
BaO(L)	Cr2O3(s)	Hg(cr)	MgBr2(s)
BaO2H2(s)	Cr2O3(L)	Hg(L)	MgBr2(L)
BaO2H2(L)	Cs(cr)	HgBr2(s)	MgCO3(s)
BaS(s)	Cs(L)	HgBr2(L)	MgCL2(s)
Be(a)	CsCL(a)	HgO(s)	MgCL2(L)
Be(b)	CsCL(b)	I2(cr)	MgF2(s)
Be(L)	CsCL(L)	I2(L)	MgF2(L)
BeAL2O4(s)	CsF(s)	K(cr)	MgI2(s)
BeAL2O4(L)	CsF(L)	K(L)	MgI2(L)
BeBr2(s)	CsOH(a)	KCN(s)	MgO(s)
BeCL2(s)	CsOH(b)	KCN(L)	MgO(L)
BeCL2(L)	CsOH(c)	KCL(s)	MgO2H2(s)
BeF2(Lqz)	CsOH(L)	KCL(L)	MgS(s)
BeF2(hqz)	Cs2SO4(II)	KF(s)	MgSO4(s)
BeF2(L)	Cs2SO4(I)	KF(L)	MgSO4(L)
BeI2(s)	Cs2SO4(L)	KHF2(a)	MgSiO3(I)
BeI2(L)	Cu(cr)	KHF2(b)	MgSiO3(II)
BeO(a)	Cu(L)	KHF2(L)	MgSiO3(III)
BeO(b)	CuF(s)	KOH(a)	MgSiO3(L)
BeO(L)	CuF2(s)	KOH(b)	MgTiO3(s)
BeO2H2(b)	CuF2(L)	KOH(L)	MgTiO3(L)

TABLE B.2.—Concluded.

MgTi ₂ O ₅ (s)	NbO (s)	SiO ₂ (b-qz)	Ti (b)
MgTi ₂ O ₅ (L)	NbO (L)	SiO ₂ (b-crt)	Ti (L)
Mg ₂ SiO ₄ (s)	NbO ₂ (I)	SiO ₂ (L)	TiC (s)
Mg ₂ SiO ₄ (L)	NbO ₂ (II)	SiS (cr)	TiC (L)
Mg ₂ TiO ₄ (s)	NbO ₂ (III)	SiS (L)	TiCl ₂ (s)
Mg ₂ TiO ₄ (L)	NbO ₂ (L)	SiS ₂ (cr)	TiCl ₃ (s)
Mn (a)	Nb ₂ O ₅ (s)	SiS ₂ (L)	TiCl ₄ (L)
Mn (b)	Nb ₂ O ₅ (L)	Si ₂ N ₂ O (s)	TiN (s)
Mn (c)	Ni (cr)	Si ₃ N ₄ (cr)	TiN (L)
Mn (d)	Ni (cr)	Sn (cr)	TiO (a)
Mn (L)	Ni (L)	Sn (L)	TiO (b)
Mo (cr)	NiS (b)	SnBr ₂ (s)	TiO (L)
Mo (L)	NiS (a)	SnBr ₂ (L)	TiO ₂ (ru)
NH ₄ Cl (a)	NiS (L)	SnBr ₄ (s)	TiO ₂ (L)
NH ₄ Cl (b)	NiS ₂ (s)	SnBr ₄ (L)	Ti ₂ O ₃ (a)
NH ₄ F (cr)	NiS ₂ (L)	SnCl ₂ (s)	Ti ₂ O ₃ (b)
NH ₄ F (L)	Ni ₃ S ₂ (I)	SnCl ₂ (L)	Ti ₂ O ₃ (L)
Na (cr)	Ni ₃ S ₂ (II)	SnCl ₄ (L)	Ti ₃ O ₅ (a)
Na (L)	Ni ₃ S ₂ (L)	SnCl ₄ (L)	Ti ₃ O ₅ (b)
NaAlO ₂ (a)	Ni ₃ S ₄ (s)	SnF ₂ (s)	Ti ₃ O ₅ (L)
NaAlO ₂ (b)	P (cr)	SnF ₂ (L)	Ti ₄ O ₇ (s)
NaBr (s)	P (L)	SnI ₂ (s)	Ti ₄ O ₇ (L)
NaBr (L)	P ₄ O ₁₀ (cr)	SnI ₂ (L)	U (a)
NaCN (s)	P ₄ O ₁₀ (L)	SnI ₄ (s)	U (b)
NaCN (L)	Pb (cr)	SnI ₄ (L)	U (c)
NaCl (s)	Pb (L)	SnO (s)	U (L)
NaCl (L)	PbBr ₂ (s)	SnO (L)	V (cr)
NaF (s)	PbBr ₂ (L)	SnO ₂ (s)	V (L)
NaF (L)	PbCl ₂ (s)	SnO ₂ (L)	VCL ₂ (s)
NaI (s)	PbCl ₂ (L)	SnS (rh)	VCL ₃ (s)
NaI (L)	PbF ₂ (II)	SnS (cu)	VCL ₄ (L)
NaOH (a)	PbF ₂ (I)	SnS (L)	VN (s)
NaOH (L)	PbF ₂ (L)	SnS ₂ (s)	VO (s)
NaO ₂ (s)	PbI ₂ (s)	Sr (a)	VO (L)
Na ₂ CO ₃ (I)	PbI ₂ (L)	Sr (b)	V ₂ O ₃ (s)
Na ₂ CO ₃ (II)	PbO (II-r)	Sr (L)	V ₂ O ₃ (L)
Na ₂ CO ₃ (L)	PbO (I-y)	SrCl ₂ (a)	V ₂ O ₄ (I)
Na ₂ O (c)	PbO (L)	SrCl ₂ (b)	V ₂ O ₄ (II)
Na ₂ O (a)	PbO ₂ (s)	SrCl ₂ (L)	V ₂ O ₄ (L)
Na ₂ O (L)	PbS (s)	SrF ₂ (s)	V ₂ O ₅ (s)
Na ₂ O ₂ (a)	PbS (L)	SrF ₂ (L)	V ₂ O ₅ (L)
Na ₂ O ₂ (b)	Pb ₂ O ₃ (s)	SrO (s)	W (cr)
Na ₂ S (1)	Pb ₃ O ₄ (s)	SrO (L)	W (L)
Na ₂ S (2)	Rb (cr)	SrO ₂ H ₂ (s)	Zn (cr)
Na ₂ S (L)	Rb (L)	SrO ₂ H ₂ (L)	Zn (L)
Na ₂ SO ₄ (V)	S (cr1)	SrS (s)	ZnSO ₄ (a)
Na ₂ SO ₄ (IV)	S (cr2)	Ta (cr)	ZnSO ₄ (a)
Na ₂ SO ₄ (I)	S (L)	Ta (L)	ZnSO ₄ (b)
Na ₂ SO ₄ (L)	SCL ₂ (L)	TaC (s)	Zr (a)
Na ₃ AlF ₆ (a)	S ₂ CL ₂ (L)	TaC (L)	Zr (b)
Na ₃ AlF ₆ (b)	Si (cr)	Ta ₂ O ₅ (s)	Zr (L)
Na ₃ AlF ₆ (L)	Si (L)	Ta ₂ O ₅ (L)	ZrN (s)
Na ₅ Al ₃ F ₁₄ (s)	SiC (b)	Th (a)	ZrN (L)
Na ₅ Al ₃ F ₁₄ (L)	SiC (b)	Th (b)	ZrO ₂ (a)
Nb (cr)	SiC (L)	Th (L)	ZrO ₂ (b)
Nb (L)	SiO ₂ (a-qz)	Ti (a)	ZrO ₂ (L)

TABLE B.3.—NAMES OF REACTANTS IN *thermo.inp*

Air	Jet-A(g)
B2H6 (L)	Jet-A(L)
B5H9 (L)	CLF3 (L)
(CH2) _x (s)	CLO3F
CH3NO2 (L)	CLO3F(L)
CH4 (L)	CL2 (L)
CH3OH (L)	F2 (L)
CH6N2 (L)	F2O (L)
C2H2 (L), acetylene	JP-4
CH3CN (L)	JP-5
C2H4 (L)	HNO3 (L)
C2H4O (L), ethylene	IRFNA
C2H6 (L)	H2 (L)
C2H5OH (L)	H2O2 (L)
C2H8N2 (L), UDMH	LiCLO4 (s)
C2N2 (L)	NF3 (L)
C3H6 (L), propylene	NH3 (L)
C3H7NO3 (L)	NH4CLO4 (I)
C3H8 (L)	NH4CLO4 (II)
C4H8 (L), 1-butene	NH4NO3 (IV)
C4H10 (L), n-butane	NH4NO3 (III)
C4H10 (L), isobutane	NH4NO3 (II)
C5H12 (L), n-pentane	NH4NO3 (I)
C6H6 (L)	NH4NO3 (L)
C6H5NH2 (L)	N2 (L)
C6H14 (L), n-hexane	N2H4 (L)
C7H8 (L)	N2O4 (L)
C7H16 (L), n-heptane	O2 (L)
C8H18 (L), n-octane	O3 (L)
C8H18 (L), isooctane	

Appendix C

Thermodynamic and Density Data for Reactants

Thermodynamic and density data for the reactants are given in tables C.1 and C.2. Some reactants are in the condensed phase; others are in the gaseous phase. Density data are given only for the condensed phase. For those reactants whose normal boiling points are below 298.15 K, the following energy data in kilojoules per mole are given in table C.1:

1. Heat of formation of the gaseous phase at 298.15 K, $\Delta H_{298.15} = H_{298.15}$
2. Sensible heat of the ideal state of the gas from 298.15 K to the boiling point, $H_{298.15} - H_{bp}$
3. Difference in enthalpy between ideal and real states of the gas at the normal boiling point, $H_{bp} - H_{bp, re}$
4. Heat of vaporization at the normal boiling point $\Delta H_{vap} = H_{bp, re} - H(c)_{bp}$

The assigned enthalpy of the condensed phase at the normal boiling point is calculated from these data by means of the formula

$$H(c)_{bp} = H(g)_{298.15} - (H_{298.15} - H_{bp}) - (H_{bp} - H_{bp, re}) - \Delta H_{vap}$$

(Note that in the thermodynamic enthalpy base in *thermo.lib*, the assigned value of enthalpy at 298.15 K ($H_{298.15}$) is equal to the heat of formation at 298.15 K (i.e., $H_{298.15} = \Delta H_{298.15}$; see eq. (4.2) in Gordon and McBride, 1994). For those species for which the quantity ($H_{bp} - H_{bp, re}$) was unknown, it was taken as zero inasmuch as it is a relatively small quantity (say, 0.1 to 0.5 kJ/mol). A blank in the temperature column indicates that the temperature is 298.15 K and not a boiling point. References for the data in table C.1 are given in table D.1 in appendix D. Table C.2 gives the data and references for reactants in the format of the *thermo.inp* file (see table A.1). For some reactants, only one enthalpy value is given.; for others, thermodynamic coefficients for heat capacity, enthalpy, and entropy are given for one or more temperature intervals. Reactant species names used in **reac** datasets should match those in tables B.1 to B.3.

TABLE C.1.—THERMODYNAMIC AND DENSITY DATA FOR REACTANTS

Species	Phase	Boiling point, K	Assigned enthalpy, kJ/mol	$H_{298.15} - H_{bp}$, kJ/mol	$H_{bp} - H_{bp,ref}$, kJ/mol	ΔH_{vap} , kJ/mol	Density, g/cm ³
Acetonitrile, C ₂ H ₃ N	L	-----	31.38	-----	-----	-----	0.7793
Acetylene, C ₂ H ₂	g	-----	228.2	4.187	0.172	16.242	-----
	L	192.35	207.599	-----	-----	-----	.729
Air ^a	g	-----	-.126	-----	-----	-----	-----
Ammonia, NH ₃	g	-----	-45.940	2.042	.222	23.351	-----
	L	239.72	-71.555	-----	-----	-----	.6821
Ammonium perchlorate, NH ₄ ClO ₄	I	-----	-295.767	-----	-----	-----	1.95
Ammonium nitrate, NH ₄ NO ₃	IV	-----	-365.6	-----	-----	-----	1.725
Aniline, C ₆ H ₅ NH ₂	L	-----	31.5	-----	-----	-----	1.02173
Benzene, C ₆ H ₆	L	-----	49.08	-----	-----	-----	.87366
Beryllium, Be	s	-----	0	-----	-----	-----	1.85
<i>n</i> -Butane, C ₄ H ₁₀	g	-----	-125.79	2.434	-----	22.44	-----
	L	272.638	-150.664	-----	-----	-----	.06012
<i>i</i> -Butane, C ₄ H ₁₀	g	-----	-134.99	3.374	-----	21.30	-----
	L	261.361	-159.664	-----	-----	-----	.5941
1-Butene, C ₄ H ₈	g	-----	-.54	2.563	-----	22.07	-----
	L	266.92	-25.173	-----	-----	-----	.6254
Chlorine, Cl ₂	g	-----	0	1.968	.172	20.410	-----
	L	239.12	-22.550	-----	-----	-----	1.559
Chlorine trifluoride, ClF ₃	g	-----	-164.6	.842	.414	27.53	-----
	L	284.89	-193.386	-----	-----	-----	1.850
Cyanogen, C ₂ N ₂	g	-----	309.100	2.561	-----	23.33	-----
	L	252.05	283.209	-----	-----	-----	.9577
Diborane, B ₂ H ₆	g	-----	36.6	5.695	.197	14.263	-----
	L	180.59	16.445	-----	-----	-----	.4371
Ethane, C ₂ H ₆	g	-----	-83.852	5.267	-----	14.70	-----
	L	184.559	-103.819	-----	-----	-----	.5465
Ethanol, C ₂ H ₅ OH	L	-----	-277.51	-----	-----	-----	.78509
Ethylene, C ₂ H ₄	g	-----	52.50	4.865	.163	13.527	-----
	L	169.42	33.945	-----	-----	-----	.5690
Ethylene oxide, C ₂ H ₄ O	g	-----	-52.635	.676	-----	25.53	-----
	L	283.65	-78.841	-----	-----	-----	.8824
Ethylene polymer, (CH ₂) _x	s	-----	-25.6	-----	-----	-----	.935
Fluorine, F ₂	g	-----	0	6.353	.078	6.66	-----
	L	85.02	-13.091	-----	-----	-----	1.5021
<i>n</i> -Heptane, C ₇ H ₁₆	L	-----	-224.35	-----	-----	-----	.67950
<i>n</i> -Hexane, C ₆ H ₁₄	L	-----	-198.66	-----	-----	-----	.65484
Hydrazine, N ₂ H ₄	L	-----	50.38	-----	-----	-----	1.0040
Hydrogen, H ₂	g	-----	0	8.043	.070	.899	-----
	L	20.27	-9.012	-----	-----	-----	.0709
Hydrogen peroxide, H ₂ O ₂	L	-----	-187.78	-----	-----	-----	1.4425
IRFNA ^b	L	-----	-270.496	-----	-----	-----	1.478
Jet-A, C ₁₂ H ₂₃ ^c	L	-----	-303.403	-----	-----	-----	.818

- a. Air is based on the following molar percents: N₂=78.084, O₂=20.9476, Ar=0.9365, CO₂, 0.0319 (Gordon, 1982). The empirical formula for 1 mole of air is N_{1.56168}O_{4.1959}Ar_{.009365}C_{.000319}.
- b. Inhibited red fuming nitric acid based on the following weight percents: HNO₃(L)=83.5, N₂O₄(L)=14, H₂O(L)=2, HF(g)=0.5. (This gives the following empirical formula defined as 1 mole: H_{1.57216}N_{1.62945}O_{4.69505}F_{.02499}.)
- c. Typical jet fuel having the following properties: empirical formula defined as 1 mole is C₁₂H₂₃ (equivalent to H/C weight ratio of 0.16084); heat of combustion, 18 500 Btu/lb.

TABLE C.1.—Concluded.

Species	Phase	Boiling point, K	Assigned enthalpy, kJ/mol	$H_{298.15} - H_{bp}$, kJ/mol	$H_{bp} - H_{bp,ref}$, kJ/mol	ΔH_{vap} , kJ/mol	Density, g/cm ³
JP-4, RP-1 ^d	L	-----	-22.723	-----	-----	-----	0.773
JP-5, ASTMA1 ^e	L	-----	-22.183	-----	-----	-----	.807
Lithium, Li	s	-----	0	-----	-----	-----	.534
	L	^f 453.69	7.187	-----	-----	-----	.512
Lithium perchlorate, LiClO ₄	s	-----	-380.7	-----	-----	-----	2.428
Methane, CH ₄	g	-----	-74.6	6.318	0.126	8.189	-----
	L	111.643	-89.233	-----	-----	-----	.4211
Methanol, CH ₃ OH	L	-----	-238.91	-----	-----	-----	.78664
Monomethyl hydrazine, CH ₆ N ₂	L	-----	54.2	-----	-----	-----	.874
Nitric acid, HNO ₃	g	-----	-133.913	-----	-----	39.1	-----
	L	-----	-173.013	-----	-----	-----	1.5037
Nitrogen, N ₂	g	-----	0	6.427	.103	5.577	-----
	L	77.352	-12.107	-----	-----	-----	.8081
Nitrogen tetroxide, N ₂ O ₄	g	-----	11.111	-----	-----	28.66	-----
	L	-----	-17.549	-----	-----	-----	1.431
Nitrogen trifluoride, NF ₃	g	-----	-131.7	6.960	.142	11.585	-----
	L	144.09	-150.387	-----	-----	-----	1.537
Nitromethane, CH ₃ NO ₂	L	-----	-113.1	-----	-----	-----	1.1286
<i>n</i> -Octane, C ₈ H ₁₈	L	-----	-250.26	-----	-----	-----	.69854
<i>i</i> -Octane, C ₈ H ₁₈	L	-----	-259.16	-----	-----	-----	.68784
Oxygen, O ₂	g	-----	0	6.065	.094	6.820	-----
	L	90.17	-12.979	-----	-----	-----	1.149
Oxygen difluoride, OF ₂	g	-----	24.5	6.608	.130	11.09	-----
	L	128.40	6.672	-----	-----	-----	1.518
Ozone, O ₃	g	-----	141.8	4.964	.113	14.196	-----
	L	161.85	122.527	-----	-----	-----	1.449
Pentaborane, B ₅ H ₉	L	-----	42.84	-----	-----	-----	.6183
<i>n</i> -Pentane, C ₅ H ₁₂	L	-----	-173.49	-----	-----	-----	.6213
Perchloryl fluoride, ClFO ₃	g	-----	-23.8	4.306	-----	19.33	-----
	L	226.40	-47.436	-----	-----	-----	1.392
Propane, C ₃ H ₈	g	-----	-104.68	4.508	-----	19.04	-----
	L	231.076	-128.228	-----	-----	-----	.5810
Propylene, C ₃ H ₆	g	-----	20.00	4.284	-----	18.42	-----
	L	225.46	-2.704	-----	-----	-----	.6093
Propyl nitrate, C ₃ H ₇ NO ₃	L	-----	-214.5	-----	-----	-----	1.0538
Toluene, C ₇ H ₈	L	-----	12.18	-----	-----	-----	.86220
Unsymmetrical dimethyl hydrazine (UDMH), C ₂ H ₈ N ₂	L	-----	48.9	-----	-----	-----	.7914

d. Typical jet fuel having the following properties: H/C weight ratio, 0.163; heat of combustion, 18 640 Btu/lb (giving the following empirical formula defined as 1 mole: C₁H_{1.9423}).

e. Typical jet fuel having the following properties: H/C weight ratio, 0.161; heat of combustion, 18 600 Btu/lb (giving the following empirical formula defined as 1 mole: C₁H_{1.9185}).

f. Melting point for Li.

TABLE C.2.—REACTANT THERMODYNAMIC DATA IN *thermo.inp* FORMAT

Air	Mole%:N2 78.084,O2 20.9476,Ar .9365,CO2 .0319.NASA TP1906 1982									
2 1 9/95 N	1.56170	.41959AR	.00937C	.00032	.00000	0	28.9651785			-125.530
	200.000	1000.0007	-2.0	-1.0	0.0	1.0	2.0	3.0	4.0	0.0
										8649.264
	1.00995016D+04	-1.96827561D+02	5.00915511D+00	-5.76101373D-03	1.06685993D-05					
	-7.94029797D-09	2.18523191D-12	0.00000000D+00	-1.76796731D+02	-3.92150098D+00					
	1000.000	6000.0007	-2.0	-1.0	0.0	1.0	2.0	3.0	4.0	0.0
										8649.264
	2.41521443D+05	-1.25787460D+03	5.14455867D+00	-2.13854179D-04	7.06522784D-08					
	-1.07148349D-11	6.57780015D-16	0.00000000D+00	6.46226319D+03	-8.14740866D+00					
B2H6(L)	Diborane. JANAF Prop.Ser.E,1/67. TPIS v.III,1981.									
0 1 4/95 B	2.00H	6.00	0.00	0.00	0.00	1	27.66964			16445.000
										180.59
B5H9(L)	Pentaborane. JANAF June 1963 p300.									
0 j 6/63 B	5.00H	9.00	0.00	0.00	0.00	1	63.12646			42840.000
										298.15
(CH2)x(s)	Ethylene polymer. Est.from paraffin HC series,TRC p-2500,4/88.									
0 1 4/95 C	1.00H	2.00	0.00	0.00	0.00	1	14.02688			-25600.000
										298.15
CH3NO2(L)	Nitromethane. TRC p-9520,12/91.									
0 x12/91 C	1.00H	3.00N	1.000	2.00	0.00	1	61.04036			-113100.000
										298.15
CH4(L)	Methane. TRC m-1350,10/93. JANAF Prop.Ser.E,1/67.									
0 1 4/95 C	1.00H	4.00	0.00	0.00	0.00	1	16.04276			-89233.000
										111.643
CH3OH(L)	Methanol. TRC p-5000,12/87; tc,uc,vc-5031-3,12/84.									
1 x12/84 C	1.00H	4.000	1.00	0.00	0.00	1	32.04216			-238910.000
	175.610	390.000	7	-2.0	-1.0	0.0	1.0	2.0	3.0	4.0
										0.0
										18995.000
	-1.30200518D+06	3.16698523D+04	-3.03124315D+02	1.60223163D+00	-4.59450874D-03					
	6.99018037D-06	-4.20739019D-09	0.00000000D+00	-1.65616865D+05	1.51434714D+03					
CH6N2(L)	Monomethyl Hydrazine. TRC p-9220,12/93.									
0 x12/93 C	1.00H	6.00N	2.00	0.00	0.00	1	46.07212			54200.000
										298.15
C2H2(L),acetylene	Acetylene. Dens:JANAF Prop.Ser.E,1/67. B.P.:TRC a-3000,10/86.									
0 1 3/95 C	2.00H	2.00	0.00	0.00	0.00	1	26.03788			207599.000
										192.35
CH3CN(L)	Ethanenitrile (Acetonitrile). JPCRD v11,Sup.2,1982.									
0 1 3/95 C	2.00H	3.00N	1.00	0.00	0.00	1	41.05256			31380.
										298.15
C2H4(L)	Ethylene. TRC m-2600,10/93.									
0 1 4/95 C	2.00H	4.00	0.00	0.00	0.00	1	28.05376			33945.000
										169.42
C2H4O(L),ethylene	Ethylene oxide (Oxirane). TRC m-6150,6/94.									
0 1 4/95 C	2.00H	4.000	1.00	0.00	0.00	1	44.05316			-78841.000
										283.65
C2H6(L)	Ethane. TRC m-1350, 10/93.									
0 1 4/95 C	2.00H	6.00	0.00	0.00	0.00	1	30.06964			-103819.000
										184.559
C2H5OH(L)	TRC p-5000,12/31/87; tc,uc,vc-5031-3,12/31/84.									
1 x12/84 C	2.00H	6.000	1.00	0.00	0.00	1	46.06904			-277510.000
	159.000	390.000	7	-2.0	-1.0	0.0	1.0	2.0	3.0	4.0
										0.0
										24082.000
	4.50111594D+05	-1.02082899D+04	1.01426678D+02	-3.87467261D-01	7.12139261D-04					
	-1.85707145D-07	-2.03762257D-10	0.00000000D+00	7.44855790D+03	-5.04425552D+02					
C2H8N2(L),UDMH	Unsymmetrical Dimethyl Hydrazine. TRC p9220,12/93.									
0 1 4/95 C	2.00H	8.00N	2.00	0.00	0.00	1	60.099			48900.000
										298.15
C2N2(L)	Cyanogen. Hdbk C&P Ed.73,1992-3.									
0 1 3/95 C	2.00N	2.00	0.00	0.00	0.00	1	52.03548			283209.000
										252.05

TABLE C.2.—Continued.

C3H6(L), propyle Propylene. TRC m2600,10/93.									
0 1 4/95 C	3.00H	6.00	0.00	0.00	0.00 1	42.08064		-2704.000	
		225.46							
C3H7NO3(L) Propyl Nitrate. Pedley,Naylor,Kirby,1986,p178.									
0 1 4/95 C	3.00H	7.00N	1.000	3.00	0.00 1	105.09352		-214500.000	
		298.15							
C3H8(L) Propane. TRC m1350,10/93.									
0 1 4/95 C	3.00H	8.00	0.00	0.00	0.00 1	44.09652		-128228.000	
		231.076							
C4H8(L),1-buten 1-Butene. TRC m-2600,10/93. p-2600,4/88.									
0 1 3/95 C	4.00H	8.0	0.00	0.00	0.00 1	56.10752		-25173.000	
		266.92							
C4H10(L),n-buta n-Butane. TRC m-1350,10/93.									
0 1 3/95 C	4.00H	10.0	0.00	0.00	0.00 1	58.12340		-150664.000	
		272.638							
C4H10(L),isobut Isobutane(2-methyl propane). TRC m-1350,10/93.									
0 1 3/95 C	4.00H	10.0	0.00	0.00	0.00 1	58.12340		-159664.000	
		261.361							
C5H12(L),n-pent n-Pentane. TRC p-1350,4/85.									
0 1 4/85 C	5.00H	12.0	0.00	0.00	0.00 1	72.15028		-173490.000	
		298.15							
C6H6(L) Benzene. TRC tc,uc,vc-3201,10/31/86; p-3200,4/30/83.									
1 x10/86 C	6.00H	6.00	0.00	0.00	0.00 1	78.11364		49080.000	
		278.680	500.000 7	-2.0 -1.0 0.0	0.0 1.0 2.0 3.0 4.0 0.0			30110.000	
		-2.56013710D+06	4.13674588D+04	-2.12297357D+02	3.72357902D-01	7.56106887D-04			
		-3.07721509D-06	2.78750625D-09	0.00000000D+00	-1.93546778D+05	1.23184575D+03			
C6H5NH2(L) Aniline. TRC p9370 6/30/90. TRC tc,uc,vc-9370 12/31/88									
1 x12/88 C	6.00H	7.00N	1.00	0.00	0.00 1	93.12832		31500.000	
		267.130	460.000 7	-2.0 -1.0 0.0	0.0 1.0 2.0 3.0 4.0 0.0			34020.000	
		6.26773441D+07	-8.94751040D+05	5.06761571D+03	-1.40216320D+01	1.89963591D-02			
		-9.31666484D-06	-1.23822249D-09	0.00000000D+00	4.27541061D+06	-2.80777408D+04			
C6H14(L),n-hexa n-hexane. TRC p,tc,uc,vc-1440-1,4/85.									
1 x 4/85 C	6.00H	14.00	0.00	0.00	0.00 1	86.17716		-198660.000	
		177.860	300.000 7	-2.0 -1.0 0.0	0.0 1.0 2.0 3.0 4.0 0.0			46920.000	
		7.73091716D+06	-2.25189247D+05	2.71990284D+03	-1.69986707D+01	5.91239759D-02			
		-1.07540944D-04	8.03043709D-08	0.00000000D+00	8.81946638D+05	-1.29413841D+04			
C7H8(L) TRC tc,uc,vc-3200-1,10/31/86; p-3200,4/30/83.									
1 x10/86 C	7.00H	8.00	0.00	0.00	0.00 1	92.14052		12180.000	
		178.150	500.000 7	-2.0 -1.0 0.0	0.0 1.0 2.0 3.0 4.0 0.0			33470.000	
		-3.71356003D+06	7.77255072D+04	-6.31228799D+02	2.72439986D+00	-6.10355386D-03			
		7.02244524D-06	-3.11372750D-09	0.00000000D+00	-3.45212505D+05	3.26599001D+03			
C7H16(L),n-hept TRC m-1460,4/93; tc,uc,vc-1460,10/31/75.									
1 x10/75 C	7.00H	16.00	0.00	0.00	0.00 1	100.20404		-224350.000	
		182.580	380.000 7	-2.0 -1.0 0.0	0.0 1.0 2.0 3.0 4.0 0.0			52640.000	
		1.76003600D+06	-3.74960173D+04	3.96325980D+02	-2.11792498D+00	6.82851971D-03			
		-1.13190177D-05	7.73709883D-09	0.00000000D+00	1.26916032D+05	-1.92178419D+03			
C8H18(L),n-octa TRC tables tc,uc,vc-1491-2. Hf298: p-1010,Oct.31,1984.									
1 x10/76 C	8.00H	18.00	0.00	0.00	0.00 1	114.23092		-250260.000	
		216.370	310.000 7	-2.0 -1.0 0.0	0.0 1.0 2.0 3.0 4.0 0.0			61490.000	
		-2.32282501D+07	4.84653545D+05	-4.08481823D+03	1.82081928D+01	-4.46566290D-02			
		5.81410134D-05	-3.14960334D-08	0.00000000D+00	-2.16627048D+06	2.09165973D+04			
C8H18(L),isooct TRC tables tc,uc,vc-1491-2. Hf298: p-1490,Oct.31,1982.									
1 x10/76 C	8.00H	18.00	0.00	0.00	0.00 1	114.23092		-259160.000	
		165.790	380.000 7	-2.0 -1.0 0.0	0.0 1.0 2.0 3.0 4.0 0.0			50190.000	
		4.78104766D+06	-1.12691138D+05	1.09652177D+03	-5.34411704D+00	1.46003724D-02			
		-2.02871999D-05	1.13340043D-08	0.00000000D+00	4.43284874D+05	-5.45790515D+03			
CLF3(L) JANAF Prop.SerD,3/66. TRC k-140,12/73.									
0 1 3/95 CL	1.00F	3.00	0.00	0.00	0.00 1	92.44791		-193386.000	
		284.89							

TABLE C.2.—Continued.

CLO3F Perchloryl Fluoride. JPCRD v22 sup2,1982. JANAF 3/61.															
2	1	5/95	CL	1.000	3.00F	1.00	0.00	0.00	0	102.44930	-23800.000				
				200.000	1000.000	7	-2.0	-1.0	0.0	1.0	2.0	3.0	4.0	0.0	13298.823
				4.46087770D+04	-5.89208408D+02	3.55871337D+00	2.80962019D-02	-3.61092477D-05							
				2.27336016D-08	-5.71680272D-12	0.00000000D+00	-1.38879811D+03	4.59151362D+00							
				1000.000	6000.000	7	-2.0	-1.0	0.0	1.0	2.0	3.0	4.0	0.0	13298.823
				-3.91041344D+05	-1.19325902D+03	1.38866330D+01	-3.54168398D-04	7.82659835D-08							
				-8.97991688D-12	4.16469843D-16	0.00000000D+00	-1.27485199D+03	-5.10649344D+01							
CLO3F(L) Perchloryl Fluoride. Hdbk C&P,ED.73,1992-3.															
0	1	4/95	CL	1.000	3.00F	1.00	0.00	0.00	1	102.44930	-47436.000				
				226.40											
CL2(L) Chlorine. HdbkC&P Ed.73,1992-3. JANAF Prop.Ser.E,1/67															
0	1	4/95	CL	2.00	0.00	0.00	0.00	0.00	1	70.90540	-22550.000				
				239.12											
F2(L) Fluorine. Hdbk C&P Ed.73 1992-3. JANAF Prop.Ser.D,3/66.															
0	1	4/95	F	2.00	0.00	0.00	0.00	0.00	1	37.99681	-13091.000				
				85.02											
F2O(L) Oxygen Difluoride.Hdbk C&P Ed.73,1992-3.JANAF Prop.Ser.E,1/67.															
0	1	4/95	F	2.000	1.00	0.00	0.00	0.00	1	53.99621	6672.000				
				128.40											
HNO3(L) Nitric Acid. Hdbk C&P Ed.73,1992-3,p6-102.															
0	1	4/95	H	1.00N	1.000	3.00	0.00	0.00	1	63.01288	-173013.000				
				298.15											
H2(L) Hydrogen. JANAF Prop.Ser.D,3/66.															
0	jp3/66	H	2.00	0.00	0.00	0.00	0.00	0.00	1	2.01588	-9012.000				
				20.27											
H2O2(L) Hydrogen Peroxide Liquid.TPIS,1989.															
1	tpis89	H	2.000	2.00	0.00	0.00	0.00	0.00	1	34.01468	-187780.000				
				272.740	6000.000	1	0.0	0.0	0.0	0.0	0.0	0.0	0.0	0.0	22949.000
				1.07438683D+01	0.00000000D+00	0.00000000D+00	0.00000000D+00	0.00000000D+00	0.00000000D+00	0.00000000D+00	0.00000000D+00	0.00000000D+00	0.00000000D+00	0.00000000D+00	0.00000000D+00
				0.00000000D+00	0.00000000D+00	0.00000000D+00	0.00000000D+00	-2.57878985D+04	-4.80322129D+01						
IRFNA Wt%: HNO3(L) 83.5; N2O4(L) 14.; H2O(L) 2.; HF(g) .5.															
0	1	4/95	H	1.5722N	1.6294O	4.6950F	.02499		1	100.	-270496.000				
				298.15											
JP-4 Also RP-1. NASA RP-1311, Part II, 1996. Hcomb = 18640.BTU/#															
0	1	5/95	C	1.00H	1.9423				1	13.96872	-22723.000				
				298.15											
JP-5 Also ASTMA1. NASA RP-1311, Part II, 1996. Hcomb = 18600.BTU/#															
0	1	5/95	C	1.00H	1.9185				1	13.94473	-22183.000				
				298.15											
Jet-A(L) NASA TM-101475,1988. Hcomb=18500 BTU/#:NASA CR-72951,1971.															
1	1	2/96	C	12.00H	23.00	0.00	0.00	0.00	1	167.31462	-303403.000				
				220.000	550.000	7	-2.0	-1.0	0.0	1.0	2.0	3.0	4.0	0.0	0.000
				-4.218467340D+05	-5.576234840D+03	1.522094335D+02	-8.610096140D-01	3.071640926D-03							
				-4.7027666120D-06	2.743009309D-09	0.00000000D+00	-3.238535350D+04	-6.780954740D+02							
Jet-A(g) NASA TM-101475,1988. NASA CR-72951,1971.															
2	1	2/96	C	12.00H	23.00	0.00	0.00	0.00	0	167.31462	-249657.000				
				273.150	1000.000	7	-2.0	-1.0	0.0	1.0	2.0	3.0	4.0	0.0	0.000
				-6.068699280D+05	8.328264220D+03	-4.312323550D+01	2.572391032D-01	-2.629316827D-04							
				1.644989491D-07	-4.645336690D-11	0.00000000D+00	-7.606965040D+04	2.794307229D+02							
				1000.000	5000.000	7	-2.0	-1.0	0.0	1.0	2.0	3.0	4.0	0.0	0.000
				1.541871660D+07	-7.433869020D+04	1.468645380D+02	-1.297042936D-02	2.159140196D-06							
				-1.887183642D-10	6.604559540D-15	0.00000000D+00	3.996323340D+05	-9.266674660D+02							
LiCLO4(s) Lithium Perchlorate. JANAF, March, 1964.															
0	j	3/64	LI	1.00CL	1.000	4.00	0.00	0.00	1	106.3913	-380700.000				
				298.15											
NF3(L) Nitrogen trifluoride. JANAF Prop.Ser.E,1/67.															
0	1	3/95	N	1.00F	3.00	0.00	0.00	0.00	1	71.001950	-150387.000				
				144.09											

TABLE C.2.—Concluded.

NH3(L) Ammonia. TRC m-500,6/56,B.P.a-500,12/63. JANAF Prop.Ser.E,1/67											
0	1	3/95	N	1.00H	3.00	0.00	0.00	0.00	1	17.03056	-71555.000
239.72											
NH4CLO4(I) Ammonium Perchlorate. JANAF Dec.1962.											
1	j12/62	N	1.00H	4.00CL	1.000	4.00	0.00	1	117.48880	-295767.000	
100.000 513.150 7 -2.0 -1.0 0.0 1.0 2.0 3.0 4.0 0.0 25238.000											
-3.07534557D+03 -2.13650594D+02 1.02158307D+01 1.65946375D-02 1.66526642D-05											
-2.30609605D-08 1.54365732D-11 0.00000000D+00 -3.82576726D+04 -4.23025427D+01											
NH4CLO4(II) Ammonium Perchlorate. JANAF Dec.1962.											
1	j12/62	N	1.00H	4.00CL	1.000	4.00	0.00	2	117.48880	-295767.000	
513.150 1500.000 7 -2.0 -1.0 0.0 1.0 2.0 3.0 4.0 0.0 25238.000											
4.29699948D+07 -3.17841780D+05 9.59143755D+02 -1.43988137D+00 1.22267365D-03											
-5.21540162D-07 8.80361276D-11 0.00000000D+00 1.68744630D+06 -5.88947816D+03											
NH4NO3(IV) Ammonium Nitrate Rhombic Crystal(IV). TPIS,1989.											
2	tpis89	N	2.00H	4.000	3.00	0.00	0.00	1	80.04344	-365600.000	
256.200 298.150 6 -2.0 -1.0 0.0 1.0 2.0 3.0 0.0 0.0 23662.000											
-1.62667900D+07 2.61460339D+05 -1.68004630D+03 5.44897154D+00 -8.58784985D-03											
5.34327778D-06 0.00000000D+00 0.00000000D+00 -1.26419517D+06 9.08569617D+03											
298.150 305.380 2 0.0 1.0 0.0 0.0 0.0 0.0 0.0 0.0 23662.000											
5.86564933D+00 3.64302887D-02 0.00000000D+00 0.00000000D+00 0.00000000D+00											
0.00000000D+00 0.00000000D+00 0.00000000D+00 -4.73393723D+04 -2.61436244D+01											
NH4NO3(III) Ammonium Nitrate Rhombic Crystal(III). TPIS,1989.											
1	tpis89	N	2.00H	4.000	3.00	0.00	0.00	3	80.04344	-365600.000	
305.380 357.250 2 0.0 1.0 0.0 0.0 0.0 0.0 0.0 23662.000											
7.23313821D+00 2.33327039D-02 0.00000000D+00 0.00000000D+00 0.00000000D+00											
0.00000000D+00 0.00000000D+00 0.00000000D+00 -4.69417938D+04 -2.92985169D+01											
NH4NO3(II) Ammonium Nitrate Tetragonal Crystal(II). TPIS,1989.											
1	tpis89	N	2.00H	4.000	3.00	0.00	0.00	4	80.04344	-365600.000	
357.250 399.000 3 0.0 1.0 3.0 0.0 0.0 0.0 0.0 23662.000											
6.02320522D+01 -1.76799354D-01 4.52882972D-07 0.00000000D+00 0.00000000D+00											
0.00000000D+00 0.00000000D+00 0.00000000D+00 -5.47863351D+04 -2.75780621D+02											
NH4NO3(I) Ammonium Nitrate Cubic Crystal(I). TPIS,1989.											
1	tpis89	N	2.00H	4.000	3.00	0.00	0.00	5	80.04344	-365600.000	
399.000 442.850 2 0.0 1.0 0.0 0.0 0.0 0.0 0.0 23662.000											
1.29532588D+01 1.56353171D-02 0.00000000D+00 0.00000000D+00 0.00000000D+00											
0.00000000D+00 0.00000000D+00 0.00000000D+00 -4.78370128D+04 -5.84851082D+01											
NH4NO3(L) Ammonium Nitrate Liquid. TPIS,1989.											
1	tpis89	N	2.00H	4.000	3.00	0.00	0.00	6	80.04344	-365600.000	
442.850 6000.000 1 0.0 0.0 0.0 0.0 0.0 0.0 0.0 23662.000											
1.93637388D+01 0.00000000D+00 0.00000000D+00 0.00000000D+00 0.00000000D+00											
0.00000000D+00 0.00000000D+00 0.00000000D+00 -4.84379330D+04 -8.90300528D+01											
N2(L) Nitrogen. TRC k-460,6/60, m-470,6/56. JANAF Prop.Ser.D,3/66.											
0	1	4/95	N	2.00	0.00	0.00	0.00	0.00	1	28.01348	-12107.000
77.352											
N2H4(L) Hydrazine. Hf298; TPIS89. Props: JANAF 12/65.											
1	j12/65	N	2.00H	4.00	0.00	0.00	0.00	1	32.04524	50380.000	
100.000 800.000 7 -2.0 -1.0 0.0 1.0 2.0 3.0 4.0 0.0 0.000											
2.08096574D+04 -7.41816770D+02 1.91656919D+01 -4.53933014D-02 1.34202426D-04											
-1.47087394D-07 6.05628828D-11 0.00000000D+00 5.73540821D+03 -8.82021397D+01											
N2O4(L) Dinitrogen tetroxide. Hvp: JANAF Prop.Ser.C,4/65.											
0	1	4/95	N	2.000	4.00	0.00	0.00	0.00	1	92.01108	-17549.000
298.15											
O2(L) Oxygen. Hvp: TRC m-10,12/63. JANAF Prop.Ser.D,3/66.											
0	1	4/95	O	2.00	0.00	0.00	0.00	0.00	1	31.99880	-12979.000
90.17											
O3(L) Ozone. Hvp: TRC m-10,12/63. JANAF Prop.Ser.E,1/67.											
0	1	4/95	O	3.00	0.00	0.00	0.00	0.00	1	47.99820	122527.000
161.85											

Appendix D

References for Reactant Data in Table C.1

References given in this appendix correspond to the data in table C.1. The references, given at the end of this appendix, are indicated in table D.1 by the following brief codes:

Code	Abbreviated reference
AUTH	Authors
FAITH	Faith: NASA CR-72951
GRACIA	Gracia: NASA TM-101475
H1	Lide: Handbook of Chem. & Phys., 73rd Ed
H2	Weast: Handbook of Chem. & Phys., 65th Ed.
J	Chase: JANAF Thermochemical Table
JCS	Banks: J. Chem. Soc.
JPR	Stull: JANAF Thermo. Data (Propellants)
MARK	Mark: Encyclopedia of Polymer Science
PED	Pedley: Thermo. Data of Organic Compounds
RD1	Pamidimukkala: JPCRD, Vol. 11, No. 1
RDS2	Wagman: JPCRD, Vol. 11, Supp. 2
SP273	Gordon: NASA SP-273, Interim Revision
TP81	Gurvich: TPIS, Vol. 3, Pts. 1 & 2, 1981
TP82	Gurvich: TPIS, Vol. 4, Pts. 1 & 2, 1982
TP89:	Gurvich: TPIS, Vol. 1, Pts. 1 & 2, 1989
TP91:	Gurvich: TPIS, Vol. 2, Pts. 1 & 2, 1991
X	TRC Thermodynamic Tables

Page numbers follow all codes except AUTH and JPR. Following JPR is a series code, either A, B, C, D, or E (examples: X w-3040 refers to reference X, page w-3040; JPR E refers to reference JPR, series E). The data from TP81, TP82, TP89, and TP91 are often found in both parts 1 and 2 of these references. In this situation the page numbers refer to part 1 with a few exceptions.

TABLE D.1.—REFERENCES FOR REACTANT DATA IN TABLE C.1

Species	Phase	Boiling point, K	Assigned enthalpy, kJ/mol	$H_{298.15}^{\circ} - H_{bp}^{\circ}$, kJ/mol	$H_{bp}^{\circ} - H_{bp,ref}^{\circ}$, kJ/mol	ΔH_{vap}° , kJ/mol	Density, g/cm ³
Acetonitrile, C ₂ H ₃ N	L	-----	RDS2 2-103	-----	-----	-----	H1 15-43
Acetylene, C ₂ H ₂	g	-----	X w-3040	AUTH	JPR E	JPR E	-----
	L	X a-3000	AUTH	-----	-----	-----	JPR E
Air	g	-----	AUTH	-----	-----	-----	-----
Ammonia, NH ₃	g	-----	TP89 354	AUTH	JPR E	X m-500	-----
	L	X a-500	AUTH	-----	-----	-----	H2 B-365
Ammonium perchlorate, NH ₄ ClO ₄	I	-----	J 747	-----	-----	-----	H1 4-38
Ammonium nitrate, NH ₄ NO ₃	IV	-----	TP89 371	-----	-----	-----	H1 4-39
Aniline, C ₆ H ₅ NH ₂	L	-----	X p-9370	-----	-----	-----	H1 3-37
Benzene, C ₆ H ₆	L	-----	X p-3200	-----	-----	-----	X d-3200
Beryllium, Be	s	-----	ref. element	-----	-----	-----	H1 4-43
<i>n</i> -Butane, C ₄ H ₁₀	g	-----	X w-1350	AUTH	-----	X m-1350	-----
	L	X m-1350	AUTH	-----	-----	-----	X d-1350
<i>i</i> -Butane, C ₄ H ₁₀	g	-----	X w-1350	AUTH	-----	X m-1350	-----
	L	X m-1350	AUTH	-----	-----	-----	X d-1350
1-Butene, C ₄ H ₆	g	-----	X w-2600	AUTH	-----	X m-2600	-----
	L	X m-2600	AUTH	-----	-----	-----	X d-2500
Chlorine, Cl ₂	g	-----	ref. element	AUTH	JPR E	H1 6-101	-----
	L	X k-120	AUTH	-----	-----	-----	X d-120
Chlorine trifluoride, ClF ₃	g	-----	TP89 194	AUTH	JPR D	H1 6-101	-----
	L	X a-140	AUTH	-----	-----	-----	JCS50 191
Cyanogen, C ₂ N ₂	g	-----	TP91 225	AUTH	-----	H1 6-104	-----
	L	H1 6-104	AUTH	-----	-----	-----	H1 4-58
Diborane, B ₂ H ₆	g	-----	TP81 35	AUTH	JPR E	JPR E	-----
	L	JPR E	AUTH	-----	-----	-----	JPR E
Ethane, C ₂ H ₆	g	-----	RD1 85	AUTH	-----	X m-1350	-----
	L	X m-1350	AUTH	-----	-----	-----	X d-1350
Ethanol, C ₂ H ₅ OH	L	-----	X p-5000	-----	-----	-----	X a-5030
Ethylene, C ₂ H ₄	g	-----	X w-2600	AUTH	JPR E	X m-2600	-----
	L	X m-2600	AUTH	-----	-----	-----	X d-2500
Ethylene oxide, C ₂ H ₄ O	g	-----	J 662	AUTH	-----	X m-6150	-----
	L	X m-6150	AUTH	-----	-----	-----	H1 3-243
Ethylene polymer, (CH ₂) _x	s	-----	AUTH	-----	-----	-----	MARK
Fluorine, F ₂	g	-----	ref. element	AUTH	JPR D	H1 6-102	-----
	L	H1 6-102	AUTH	-----	-----	-----	X d-90
<i>n</i> -Heptane, C ₇ H ₁₆	L	-----	X p-1010	-----	-----	-----	X d-1460
<i>n</i> -Hexane, C ₆ H ₁₄	L	-----	X p-1440	-----	-----	-----	X a-1010
Hydrazine, N ₂ H ₄	L	-----	TP89 361	-----	-----	-----	X a-500
Hydrogen, H ₂	g	-----	ref. element	JPR E	JPR E	JPR E	-----
	L	JPR E	AUTH	-----	-----	-----	JPR D

TABLE D.1—Continued.

Species	Phase	Boiling point, K	Assigned enthalpy, kJ/mol	$H_{298.15} - H_{bp}$, kJ/mol	$H_p - H_{bp,ref}$, kJ/mol	ΔH_{vap} , kJ/mol	Density, g/cm ³
Hydrogen peroxide, H ₂ O ₂	L	-----	X p-30	-----	-----	-----	X d-30
IRFNA	L	-----	AUTH	-----	-----	-----	AUTH
Jet-A	L	-----	GRACIA	-----	-----	-----	FAITH
JP-4, RP-1	L	-----	AUTH	-----	-----	-----	SP273
JP-5, ASTMA1	L	-----	AUTH	-----	-----	-----	SP273
Lithium, Li	s	-----	ref. element	-----	-----	-----	H1 4-69
	L	TP82 286	TP82 286	-----	-----	-----	SP273
Lithium perchlorate, LiClO ₄	s	-----	J 763	-----	-----	-----	H1 4-469
Methane, CH ₄	g	-----	TP91 46	AUTH	JPR E	Xm-1350	-----
	L	X m-1010	AUTH	-----	-----	-----	X d-1010
Methanol, CH ₃ OH	L	-----	X p-5000	-----	-----	-----	X a-5030
Monomethyl hydrazine, CH ₆ N ₂	L	-----	X p-9220	-----	-----	-----	H1 3-283
Nitric acid, HNO ₃	g	-----	TP89 231	-----	-----	H1 6-102	-----
	L	-----	AUTH	-----	-----	-----	X a-510
Nitrogen, N ₂	g	-----	ref. element	AUTH	JPR D	X m-470	-----
	L	X k-460	AUTH	-----	-----	-----	H1 4-79
Nitrogen tetroxide, N ₂ O ₄	g	-----	TP89 212	-----	-----	JPR C	-----
	L	-----	AUTH	-----	-----	-----	JPR C
Nitrogen trifluoride, NF ₃	g	-----	TP89 376	AUTH	JPR E	JPR E	-----
	L	X a-520	AUTH	-----	-----	-----	H1 4-79
Nitromethane, CH ₃ NO ₂	L	-----	X p-9520	-----	-----	-----	H1 15-47
<i>n</i> -Octane, C ₈ H ₁₈	L	-----	X p-1010	-----	-----	-----	X d-1490
<i>i</i> -Octane, C ₈ H ₁₈	L	-----	X p-1490	-----	-----	-----	X d-1493
Oxygen, O ₂	g	-----	ref. element	AUTH	JPR D	X m-10	-----
	L	X m-10	AUTH	-----	-----	-----	H1 4-80
Oxygen difluoride, OF ₂	g	-----	TP89 162	AUTH	JPR E	H1 6-102	-----
	L	H1 6-102	AUTH	-----	-----	-----	X d-90
Ozone, O ₃	g	-----	TP89 103	AUTH	JPR E	X m-10	-----
	L	X m-10	AUTH	-----	-----	-----	JPR E
Pentaborane, B ₅ H ₉	L	-----	J 300	-----	-----	-----	JPR A
<i>n</i> -Pentane, C ₅ H ₁₂	L	-----	X p-1350	-----	-----	-----	X a-1010
Perchloryl fluoride, ClFO ₃	g	-----	RDS2 2-49	AUTH	-----	H1 6-101	-----
	L	H1 6-101	AUTH	-----	-----	-----	H1 4-53
Propane, C ₃ H ₈	g	-----	X w-1350	AUTH	-----	X m-1350	-----
	L	X m-1350	AUTH	-----	-----	-----	X d-1350
Propylene, C ₃ H ₆	g	-----	X w-2600	AUTH	-----	X m-2600	-----
	L	X m-2600	AUTH	-----	-----	-----	X d-2600
Propyl nitrate, C ₃ H ₇ NO ₃	L	-----	PED 178	-----	-----	-----	H1 3-427
Toluene, C ₇ H ₈	L	-----	X p-3200	-----	-----	-----	X a-3200
Unsymmetrical dimethyl hydrazine (UDMH), C ₂ H ₈ N ₂	L	-----	X p-9220	-----	-----	-----	H1 3-283

TABLE D.1.—Concluded.

References:

- AUTH: Calculated by the authors (assigned enthalpy either from the equation in appendix C or from heats of combustion for jet fuels; sensible heat from molecular data).
- FAITH: Faith, L.E., Ac zerman, G.H., and Henderson, H.T., 1971, "Heat Sink Capability of Jet A Fuel: Heat Transfer and Coking Studies," NASA CR-72951.
- GRACIA: Gracia-Salcedo, C.M., Brabbs, T.A., and McBride, B.J., 1988, "Experimental Verification of the Thermodynamic Properties for a Jet-A Fuel," NASATM-101475.
- H1: Lide, D.R., ed., 1992, *CRC Handbook of Chemistry and Physics*, 73th Ed., CRC Press, Inc., Boca Raton, FL.
- H2: Weast, R.C., ed., 1984, *CRC Handbook of Chemistry and Physics*, 65th Ed., CRC Press, Inc. Boca Raton, FL.
- J: Chase, M.W., Jr., ed., 1985, "JANAF Thermochemical Tables," Third Ed., Pts. 1 & 2, *J. Phys. and Chem. Ref. Data*, Vol. 14, Suppl. 1.
- JCS: Banks, A.A.; and Rudge, A.J., 1950, "The Determination of the Liquid Density of Chlorine Trifluoride," *J. Chem. Soc.*, Pt. I, pp. 191-193.
- JPR: Joint Army-Navy-Air Force Thermochemical Panel, "JANAF Thermochemical Data," Dow Chemical Co., Midland, MI, Ser. A, June 1963; Ser. B, Jan. 2, 1964; Ser. C, Apr. 1965; Ser. D, Mar. 1966; Ser. E, Jan. 1967.
- MARK: Mark, H.F., Gaylord, N.G., and Bikales, N.M., eds., 1967, *Encyclopedia of Polymer Science and Technology*, Vol. 6. Interscience Publishers, New York, p. 304.
- PED: Pedley, J.B., Naylor, R.D., and Kirby, S.P., 1986, *Thermochemical Data of Organic Compounds*, Second Ed., Chapman and Hall, London.
- RD1: Pamidimukkala, K.M., Rogers, D., and Skinner, G.B., 1982, "Ideal Gas Thermodynamic Properties of CH₃, CD₃, CD₄, C₂D₂, C₂D₄, C₂D₆, C₂H₆, CH₃N₂CH₃," *J. Phys. and Chem. Ref. Data*, Vol. 11, No. 1, pp. 83-99.
- RDS2: Wagman, D.D., et al., 1982, "The NBS Tables of Chemical Thermodynamic Properties, Selected Values For Inorganic and C₁ and C₂ Organic Substances in SI Units," *J. Phys. Chem. Ref. Data*, Vol. 11, Suppl. 2.
- SP273: Gordon, S., and McBride, B.J., 1976, *Computer Program for Calculation of Complex Chemical Equilibrium Compositions, Rocket Performance, Incident and Reflected Shocks, and Chapman-Jouget Detonations*, NASA SP-273 (Interim Revision).
- TP81: Gurvich, L.V., et al., 1981, *Thermodynamic Properties of Individual Substances*, Vol. III, Pts. 1-2, Nauka, Moscow, U.S.S.R.
- TP82: Gurvich, L.V., et al., 1982, *Thermodynamic Properties of Individual Substances*, Vol. IV, Pts. 1-2, Nauka, Moscow, U.S.S.R.
- TP89: Gurvich, L.V., Veyts, I.V., and Alcock, C.B., 1989, *Thermodynamic Properties of Individual Substances*, Fourth Ed., Vol. 1, Pts. 1 & 2, Hemisphere Publishing Corp., Washington, DC.
- TP91: Gurvich, L.V., Veyts, I.V., and Alcock, C.B., 1991, *Thermodynamic Properties of Individual Substances*, Fourth Ed., Vol. 1, Pts. 1 & 2, Hemisphere Publishing Corp., Washington, DC.
- X: Anon., 1985-1986, *TRC Thermodynamic Tables, Nonhydrocarbons*; or *TRC Thermodynamic Tables, Hydrocarbons*. Thermodynamics Research Center, Texas A&M University, College Station, TX. (Looseleaf Tables.)

Appendix E

Format and List of Species With Thermal Transport Property Data

Most of the library of thermal transport property data in the form of least-squares coefficients (*trans.inp*) are taken from Svehla (1995). However, since the publication of his report, Mr. Svehla has revised some of the data (Svehla, 1996). At present, this library contains data for 65 reaction products and 42 binary interaction parameters. However, as data for species or interactions are added, revised, or deleted, these numbers may change. The format for the functional form used in *trans.inp* is given in table E.1. The current set of least-squares coefficients in *trans.inp* is given in table E.2. This set replaces the set given in table III of Svehla (1995). The last column in table E.2 indicates whether the coefficients were taken from Svehla (1995) or Svehla (1996). Chapter 1 and section 5.25 discuss processing the *trans.inp* data and storing the processed data in *trans.lib* for subsequent use in the CEA program.

TABLE E.1.—FORMAT FOR THERMAL TRANSPORT PROPERTY DATA

Records	Contents	Format	Columns
1 ^a	Species name	A15	1-15
	Second species name if binary interaction (blank for pure species)	A15	17-31
	V if there are viscosity coefficients	A1	35
	Temperature intervals for viscosity (0, 1, 2, or 3)	I1	36
	C if there are thermal conductivity coefficients	A1	37
	Temperature intervals for thermal conductivity (0, 1, 2, or 3)	I1	38
	Comments (references, date, etc.)	A40	41-80
Any number from 1 to 6 ^b	V if coefficients are for viscosity	A1	2
	C if coefficients are for thermal conductivity	A1	2
	First and last temperatures of temperature interval	2F9.2	3-20
	Four coefficients in equations below ^c	4E15.8	21-80

- Header record for each pure species or binary interaction.
- The number of records for each pure species or binary interaction equals the sum of the number of temperature intervals for both viscosity and thermal conductivity (sum of numbers in columns 36 and 38 of header record). Temperature intervals must be in increasing order. Viscosity or thermal conductivity order is immaterial. Any number of species is permitted between the first record (tran) and the last record (end).
- The empirical equations follow (coefficients are different for each property):

$$\left. \begin{array}{l}
 \text{Viscosity: } \ln \eta \\
 \text{Thermal conductivity: } \ln \lambda \\
 \text{Interaction parameter: } \ln \eta_{(i,j)}
 \end{array} \right\} = A \ln T + \frac{B}{T} + \frac{C}{T^2} + D$$

TABLE E.2.—VISCOSITY AND THERMAL CONDUCTIVITY COEFFICIENTS IN *trans.inp*

		trans.inp File						Ref.
transport property coefficients								
Ar		V3C3 BICH ET AL (1990)						
V	200.0 1000.0	0.61205763E	00-0.67714354E	02	0.19040660E	03	0.21588272E	01 a
V	1000.0 5000.0	0.69357334E	00	0.70953943E	02-0.28386007E	05	0.14856447E	01 a
V	5000.0 15000.0	0.76608935E+00	0.67867215E+03-0.84991417E+06				0.77935167E+00	b
C	200.0 1000.0	0.60968928E	00-0.70892249E	02	0.58420624E	03	0.19337152E	01 a
C	1000.0 5000.0	0.69075463E	00	0.62676058E	02-0.25667413E	05	0.12664189E	01 a
C	5000.0 15000.0	0.76269502E+00	0.62341752E+03-0.71899552E+06				0.56927918E+00	b
BCL3		V2C2 SVEHLA (1962)						
V	300.0 1000.0	0.52572590E	00-0.27803504E	03	0.19159256E	05	0.24373790E	01 a
V	1000.0 5000.0	0.62929553E	00-0.60723560E	02-0.37711618E	05	0.15615047E	01 a	
C	300.0 1000.0	0.41518585E	00-0.48149960E	03	0.30788060E	05	0.33168239E	01 a
C	1000.0 5000.0	0.61148589E	00-0.18167042E	03-0.20976969E	05	0.17127671E	01 a	
BF3		V2C2 SVEHLA (1962,1994)						
V	300.0 1000.0	0.58778079E	00-0.96213686E	02-0.37660007E	03	0.21035273E	01 a	
V	1000.0 5000.0	0.64430285E	00	0.73362845E	01-0.23890605E	05	0.16330508E	01 a
C	300.0 1000.0	0.39288181E	00-0.53781426E	03	0.39023491E	05	0.42287006E	01 a
C	1000.0 5000.0	0.60695214E	00-0.19889031E	03-0.23403767E	05	0.24734586E	01 a	
Br2		V2C2 SVEHLA (1962,1994)						
V	300.0 1000.0	0.45241871E	00-0.52542766E	03	0.61354230E	05	0.35322870E	01 a
V	1000.0 5000.0	0.60111079E	00-0.22499274E	03-0.14517179E	05	0.22805949E	01 a	
C	300.0 1000.0	0.13579199E	00-0.80137295E	03	0.83046621E	05	0.48052172E	01 a
C	1000.0 5000.0	0.13602376E	00-0.21904601E	04	0.77769913E	06	0.54980508E	01 a
C		V2C2 BIOLSI (1982)						
V	1000.0 5000.0	0.80124735E+00	0.17261643E+03-0.69940019E+05				0.88364870E-01	b
V	5000.0 15000.0	0.10344416E+01	0.31310924E+04-0.45512020E+07-0.23102402E+01				0.23102402E+01	b
C	1000.0 5000.0	0.80224051E+00	0.17739617E+03-0.72350849E+05				0.10329911E+01	b
C	5000.0 15000.0	0.10355137E+01	0.31489830E+04-0.45854028E+07-0.13676372E+01				0.13676372E+01	b
C		V1C0 CAPITELLI & FICOCELLI (1973)						
V	4000.0 15000.0	0.12635466E+01	0.46866528E+04-0.59789292E+07-0.43066246E+01				0.43066246E+01	b
CCLF3		V2C2 SVEHLA (1994)						
V	300.0 1000.0	0.57775962E	00-0.11595656E	03	0.13894846E	04	0.20719367E	01 a
V	1000.0 5000.0	0.64278913E	00	0.18533422E	01-0.25000775E	05	0.15313091E	01 a
C	300.0 1000.0	0.30701673E	00-0.58621120E	03	0.37562739E	05	0.45977739E	01 a
C	1000.0 5000.0	0.59447897E	00-0.25405493E	03	0.15214514E	05	0.23022470E	01 a
CCL2F2		V2C2 SVEHLA (1994)						
V	300.0 1000.0	0.55188576E	00-0.18084616E	03	0.74399094E	04	0.22089157E	01 a
V	1000.0 5000.0	0.63820813E	00-0.16395245E	02-0.31624406E	05	0.14872353E	01 a	
C	300.0 1000.0	0.37505967E	00-0.45975338E	03	0.13246268E	05	0.38355232E	01 a
C	1000.0 5000.0	0.59226968E	00-0.25988712E	03	0.21916978E	05	0.21265525E	01 a
CCL3F		V2C2 SVEHLA (1994)						
V	300.0 1000.0	0.52599241E	00-0.27466441E	03	0.18699061E	05	0.23965367E	01 a
V	1000.0 5000.0	0.62963969E	00-0.58775545E	02-0.37421689E	05	0.15207986E	01 a	
C	300.0 1000.0	0.25082525E	00-0.69236016E	03	0.58465610E	05	0.46480202E	01 a
C	1000.0 5000.0	0.58847038E	00-0.29613903E	03	0.29176214E	05	0.19487185E	01 a
CCL4		V2C2 SVEHLA (1994)						
V	300.0 1000.0	0.52914726E	00-0.26173707E	03	0.16983586E	05	0.22508228E	01 a
V	1000.0 5000.0	0.63117223E	00-0.50873987E	02-0.37435436E	05	0.13896152E	01 a	
C	300.0 1000.0	0.39796301E	00-0.45970713E	03	0.25887539E	05	0.32182809E	01 a
C	1000.0 5000.0	0.60345477E	00-0.22665258E	03	0.12105253E	05	0.15795218E	01 a
CF4		V2C2 BOUSHEHRI ET AL (1987) SVEHLA (1994)						
V	300.0 1000.0	0.62364242E	00-0.15734540E	02-0.11268526E	05	0.17826560E	01 a	
V	1000.0 5000.0	0.52895824E	00-0.34441290E	03	0.10572786E	06	0.26483931E	01 a
C	300.0 1000.0	0.29102001E	00-0.62544847E	03	0.40137545E	05	0.50559989E	01 a
C	1000.0 5000.0	0.46958735E	00-0.71864138E	03	0.17601542E	06	0.37798145E	01 a

TABLE E.2.—Continued.

CHCLF2		V2C2 SVEHLA (1994)							
V	300.0	1000.0	0.55518512E	00-0.19151112E	03	0.92302454E	04	0.22465942E	01 a
V	1000.0	5000.0	0.63832814E	00-0.18642363E	02-0.35632589E	05	0.15442566E	01 a	
C	300.0	1000.0	0.57111784E	00-0.40344356E	03	0.76841854E	04	0.26855196E	01 a
C	1000.0	5000.0	0.57237181E	00-0.42144805E	03	0.17313314E	05	0.26852328E	01 a
CHCL2F		V2C2 SVEHLA (1994)							
V	300.0	1000.0	0.54261029E	00-0.23693132E	03	0.14722387E	05	0.22950603E	01 a
V	1000.0	5000.0	0.63322050E	00-0.43091499E	02-0.36892355E	05	0.15269221E	01 a	
C	300.0	1000.0	0.64554399E	00-0.29614334E	03-0.34305973E	04	0.18524599E	01 a	
C	1000.0	5000.0	0.58133799E	00-0.38461009E	03	0.86999769E	04	0.23723154E	01 a
CHCL3		V2C2 SVEHLA (1962,1994)							
V	300.0	1000.0	0.52563815E	00-0.28025371E	03	0.19479241E	05	0.23475804E	01 a
V	1000.0	5000.0	0.62913497E	00-0.61794789E	02-0.38001753E	05	0.14716717E	01 a	
C	300.0	1000.0	0.43704658E	00-0.53648192E	03	0.29187663E	05	0.32672103E	01 a
C	1000.0	5000.0	0.55383193E	00-0.51059645E	03	0.74636570E	05	0.23891512E	01 a
CHF3		V2C2 SVEHLA (1994)							
V	300.0	1000.0	0.58092199E	00-0.11862927E	03	0.25039931E	04	0.20948315E	01 a
V	1000.0	5000.0	0.64363521E	00-0.70920001E	00-0.25099472E	05	0.15713073E	01 a	
C	300.0	1000.0	0.73882642E	00-0.17058713E	03-0.32698111E	05	0.16126977E	01 a	
C	1000.0	5000.0	0.58787951E	00-0.35203256E	03-0.17448254E	05	0.28215977E	01 a	
CH2CL2		V2C2 SVEHLA (1994)							
V	300.0	1000.0	0.57185884E	00-0.34599168E	03	0.32975791E	05	0.21786059E	01 a
V	1000.0	5000.0	0.60922943E	00-0.18784625E	03-0.27411214E	05	0.18227006E	01 a	
C	300.0	1000.0	0.25979341E	00-0.10510041E	04	0.11078850E	06	0.51956543E	01 a
C	1000.0	5000.0	0.48080771E	00-0.95120530E	03	0.17139452E	06	0.35085367E	01 a
CH3CL		V2C2 MONCHICK & MASON (1961) SVEHLA (1994)							
V	300.0	1000.0	0.58181268E	00-0.30714376E	03	0.27516618E	05	0.20941516E	01 a
V	1000.0	5000.0	0.61479454E	00-0.16327574E	03-0.27926072E	05	0.17778956E	01 a	
C	300.0	1000.0	0.43048390E	00-0.96586387E	03	0.91616260E	05	0.44424192E	01 a
C	1000.0	5000.0	0.44418462E	00-0.11573896E	04	0.19422838E	06	0.44366915E	01 a
CH4		V2C2 BOUSHEHRI ET AL (1987) SVEHLA (1994)							
V	200.0	1000.0	0.57643622E	00-0.93704079E	02	0.86992395E	03	0.17333347E	01 a
V	1000.0	5000.0	0.66400044E	00	0.10860843E	02-0.76307841E	04	0.10323984E	01 a
C	200.0	1000.0	0.10238177E	01-0.31092375E	03	0.32944309E	05	0.67787437E	00 a
C	1000.0	5000.0	0.77485028E	00-0.40089627E	03-0.46551082E	05	0.25671481E	01 a	
CH4		V2C0 SVEHLA (1994)							
V	300.0	1000.0	0.68971658E	00-0.82884483E	00-0.47557575E	04	0.11497470E	01 a	
V	1000.0	5000.0	0.69426262E	00-0.17685146E	02	0.59452784E	04	0.11244994E	01 a
CH3OH		V2C2 MONCHICK & MASON (1961) SVEHLA (1994)							
V	300.0	1000.0	0.58408390E	00-0.30677174E	03	0.27569892E	05	0.19794348E	01 a
V	1000.0	5000.0	0.61454903E	00-0.16540203E	03-0.27881995E	05	0.16830713E	01 a	
C	300.0	1000.0	0.33374512E	00-0.11617154E	04	0.10894211E	06	0.57684124E	01 a
C	1000.0	5000.0	0.42733576E	00-0.12682528E	04	0.20900463E	06	0.51283860E	01 a
CO		V3C3 SVEHLA (1994)							
V	200.0	1000.0	0.62526577E	00-0.31779652E	02-0.16407983E	04	0.17454992E	01 a	
V	1000.0	5000.0	0.87395209E	00	0.56152222E	03-0.17394809E	06-0.39335958E	00 a	
V	5000.0	15000.0	0.88503551E+00	0.90902171E+03	-0.73129061E+06	-0.53503838E+00		b	
C	200.0	1000.0	0.85439436E+00	0.10573224E+03	-0.12347848E+05	0.47793128E+00		b	
C	1000.0	5000.0	0.88407146E+00	0.13357293E+03	-0.11429640E+05	0.24417019E+00		b	
C	5000.0	15000.0	0.24175411E+01	0.80462671E+04	0.31090740E+07	-0.14516932E+02		b	
CO		V3C0 SVEHLA (1995)							
V	300.0	1000.0	0.68926185E	00-0.13796096E	01-0.46847568E	04	0.13060681E	01 b	
V	1000.0	5000.0	0.69417954E	00-0.18021840E	02	0.60950694E	04	0.12779603E	01 b
V	5000.0	10000.0	0.61979004E+00	-0.79830067E+03	0.11130858E+07	0.20233248E+01		b	

TABLE E.2.—Continued.

CO	N2	V3C0	SVEHLA (1994)						
V	200.0	1000.0	0.62526577E	00-0.31779652E	02-0.16407983E	04	0.17454992E	01	a
V	1000.0	5000.0	0.87395209E	00	0.56152222E	03-0.17394809E	06-0.39335958E	00	a
V	5000.0	15000.0	0.88503551E+00	0.90902171E+03	-0.73129061E+06	-0.53503838E+00			b
CO	O2	V3C0	SVEHLA (1994)						
V	300.0	1000.0	0.70122551E	00	0.51717887E	01-0.14240838E	04	0.12895991E	01
V	1000.0	5000.0	0.66744478E	00-0.86348036E	02	0.27445341E	05	0.15855986E	01
V	5000.0	15000.0	0.21151565E+00	-0.91881544E+04	0.18253525E+08	0.65600002E+01			b
COS		V2C2	SVEHLA (1962)						
V	300.0	1000.0	0.52573161E	00-0.27668290E	03	0.18982511E	05	0.25359860E	01
V	1000.0	5000.0	0.62947137E	00-0.59744762E	02-0.37616630E	05	0.16590382E	01	a
C	300.0	1000.0	0.56172985E	00-0.42167958E	03	0.28198920E	05	0.26921796E	01
C	1000.0	5000.0	0.65503267E	00-0.17103349E	03-0.50472397E	05	0.18756918E	01	a
CO2		V3C3	BOUSHEHRI ET AL (1987)	SVEHLA (1994)					
V	200.0	1000.0	0.51137258E	00-0.22951321E	03	0.13710678E	05	0.27075538E	01
V	1000.0	5000.0	0.63978285E	00-0.42637076E	02-0.15522605E	05	0.16628843E	01	a
V	5000.0	10000.0	0.72150912E+00	0.75012895E+03	-0.11825507E+07	0.85493645E+00			b
C	200.0	1000.0	0.48056568E+00	-0.50786720E+03	0.35088811E+05	0.36747794E+01			b
C	1000.0	5000.0	0.69857277E+00	-0.11830477E+03	-0.50688859E+05	0.18650551E+01			b
C	5000.0	10000.0	0.10518358E+01	-0.42555944E+04	0.14288688E+08	-0.88950473E+00			b
CO2	H2	V3C0	SVEHLA (1994)						
V	300.0	1000.0	0.66101867E	00-0.40651732E	02-0.42877325E	04	0.74444661E	00	a
V	1000.0	5000.0	0.70351908E	00	0.19946369E	02-0.13336698E	05	0.39931502E	00
V	5000.0	10000.0	0.66401272E+00	-0.33671205E+03	0.41670634E+06	0.78993145E+00			b
CO2	H2O	V3C0	SVEHLA (1994)						
V	300.0	1000.0	0.56499100E	00-0.32219550E	03	0.26301733E	05	0.26351165E	01
V	1000.0	5000.0	0.68455483E	00-0.33114757E	02-0.58456473E	05	0.16048763E	01	a
V	5000.0	10000.0	0.70748069E+00	0.11586070E+03	-0.22772841E+06	0.13865863E+01			b
CO2	N2	V3C0	SVEHLA (1994)						
V	300.0	1000.0	0.68926185E	00-0.13796096E	01-0.46847568E	04	0.13060681E	01	a
V	1000.0	5000.0	0.69417954E	00-0.18021840E	02	0.60950694E	04	0.12779603E	01
V	5000.0	10000.0	0.61979004E+00	-0.79830067E+03	0.11130858E+07	0.20233248E+01			b
CO2	O2	V3C0	SVEHLA (1994)						
V	300.0	1000.0	0.55753165E	00-0.17140020E	03	0.72594450E	04	0.24603725E	01
V	1000.0	5000.0	0.66011947E	00	0.25362441E	02-0.39828007E	05	0.16020458E	01
V	5000.0	10000.0	0.66564107E+00	0.13062608E+03	-0.27519463E+06	0.15433736E+01			b
CS2		V2C2	SVEHLA (1962)						
V	300.0	1000.0	0.54573740E	00-0.36042852E	03	0.33177885E	05	0.23235206E	01
V	1000.0	5000.0	0.61427787E	00-0.15337427E	03-0.36078656E	05	0.17122621E	01	a
C	300.0	1000.0	0.52603181E	00-0.50780062E	03	0.41502601E	05	0.26684257E	01
C	1000.0	5000.0	0.66331137E	00-0.15058989E	03-0.68462565E	05	0.14728865E	01	a
C2H2, acetylene		V2C2	SVEHLA (1962,1994)						
V	300.0	1000.0	0.56299896E	00-0.15304865E	03	0.46019734E	04	0.18854528E	01
V	1000.0	5000.0	0.64038318E	00-0.72360229E	01-0.29612277E	05	0.12393032E	01	a
C	300.0	1000.0	0.84030505E	00-0.10051610E	03-0.26171483E	05	0.11926036E	01	a
C	1000.0	5000.0	0.62672572E	00-0.58147342E	03	0.10751724E	06	0.30152260E	01
C2H4		V2C2	BOUSHEHRI ET AL (1987)	SVEHLA (1994)					
V	200.0	1000.0	0.59136053E	00-0.14088938E	03	0.30012800E	04	0.17018932E	01
V	1000.0	5000.0	0.66000894E	00	0.39114999E	02-0.52676489E	05	0.11033601E	01
C	200.0	1000.0	0.24736650E	00-0.10589987E	04	0.89911568E	05	0.64456092E	01
C	1000.0	5000.0	0.51616035E	00-0.92486351E	03	0.15723887E	06	0.43873845E	01
C2H6		V2C2	BOUSHEHRI ET AL (1987)	SVEHLA (1994)					
V	200.0	1000.0	0.59089348E	00-0.13994405E	03	0.29868374E	04	0.15988866E	01
V	1000.0	5000.0	0.66061323E	00	0.41062220E	02-0.52656212E	05	0.99191640E	00
C	200.0	1000.0	0.70867490E	00-0.63016563E	03	0.50951026E	05	0.29508724E	01
C	1000.0	5000.0	0.57947247E	00-0.64990228E	03-0.37806714E	04	0.39178395E	01	a

TABLE E.2.—Continued.

C2H5OH		V2C2 SVEHLA (1994)									
V	300.0	1000.0	0.54586031E	00-0.31382676E	03	0.26089200E	05	0.21078504E	01	a	
V	1000.0	5000.0	0.61957901E	00-0.11935847E	03-0.34285357E	05	0.14645259E	01	a		
C	300.0	1000.0	0.22185435E	00-0.12251941E	04	0.11716632E	06	0.65571580E	01	a	
C	1000.0	5000.0	0.42915840E	00-0.12128199E	04	0.21462928E	06	0.50153152E	01	a	
C2N2		V2C2 SVEHLA (1962)									
V	300.0	1000.0	0.52471007E	00-0.28839713E	03	0.20625913E	05	0.23625791E	01	a	
V	1000.0	5000.0	0.62832879E	00-0.66440897E	02-0.38542772E	05	0.14840188E	01	a		
C	300.0	1000.0	0.76361743E	00-0.24078764E	03	0.11152243E	05	0.13726624E	01	a	
C	1000.0	5000.0	0.66495585E	00-0.19733792E	03-0.59902201E	05	0.20817971E	01	a		
CL2		V2C2 SVEHLA (1994)									
V	300.0	1000.0	0.53516134E	00-0.23624735E	03	0.13738454E	05	0.24970463E	01	a	
V	1000.0	5000.0	0.63348430E	00-0.38786240E	02-0.35830615E	05	0.16699633E	01	a		
C	300.0	1000.0	0.34156262E	00-0.46059166E	03	0.34712872E	05	0.37412367E	01	a	
C	1000.0	5000.0	0.87392526E	00-0.19876120E	03-0.28784264E	05-0.53204988E	00	a			
D2		V2C2 SVEHLA (1994)									
V	200.0	1000.0	0.74566381E	00	0.43611949E	02-0.32396252E	04	0.48064872E	00	a	
V	1000.0	5000.0	0.96835229E	00	0.68241861E	03-0.21129775E	06-0.14883773E	01	a		
C	200.0	1000.0	0.11180891E	01	0.29771761E	03-0.23323095E	05	0.94208300E-01	a		
C	1000.0	5000.0	0.10670411E	01	0.49811245E	03-0.14904299E	06	0.37216028E	00	a	
D2O		V2C2 MATSUNAGA & NAGASHIMA(1983) SVEHLA(1994)									
V	300.0	1000.0	0.51773336E	00-0.66413680E	03	0.82973607E	05	0.29575078E	01	a	
V	1000.0	5000.0	0.58703537E	00-0.55101540E	03	0.61063786E	05	0.23875750E	01	a	
C	300.0	1000.0	0.74656939E	00-0.10592831E	04	0.17838377E	06	0.26602773E	01	a	
C	1000.0	5000.0	0.50642285E	00-0.16925317E	04	0.37493403E	06	0.47558493E	01	a	
e-		V1C1 MASON ET AL (1967)									
V	2000.0	5000.0	0.59319174E	01	0.56594215E	04-0.22576125E	07-0.53458874E	02	a		
C	2000.0	5000.0	0.59320964E	01	0.56601476E	04-0.22577332E	07-0.42512600E	02	a		
e- H		V2C0 CAPITELLI ET AL (1976)									
V	2000.0	8000.0	0.12996657E+01	0.29049200E+04-0.19315880E+07-0.96081497E+01	b						
V	8000.0	15000.0	0.13439163E+01	0.62981265E+04-0.14088393E+08-0.10240040E+02	b						
e- H2		V2C0 CAPITELLI ET AL (1976)									
V	1000.0	8000.0	0.13682927E+01	0.70665102E+04-0.56748561E+07-0.10480386E+02	b						
V	8000.0	15000.0	0.20875514E+01	0.27345700E+05-0.63775336E+08-0.18571585E+02	b						
e- N		V2C0 CAPITELLI & DEVOTO (1973)									
V	5000.0	10000.0	0.14373966E+01	0.18230345E+05-0.27492090E+08-0.96279246E+01	b						
V10000.0	15000.0	0.22566004E+01	0.48916050E+05-0.13996043E+09-0.19116958E+02	b							
e- NO		V2C0 GUPTA ET AL (1990)									
V	2000.0	6000.0	0.61252493E+00	0.46768585E+04-0.30292080E+07-0.30467956E+01	b						
V	6000.0	15000.0	-0.31058569E+01-0.69841116E+05	0.15359384E+09	0.37370344E+02	b					
e- N2		V2C0 CAPITELLI & DEVOTO (1973)									
V	5000.0	10000.0	0.22167522E+01	0.22078280E+05-0.26142843E+08-0.18975334E+02	b						
V10000.0	15000.0	0.14276153E+01	0.81306835E+04	0.41382925E+07-0.10615166E+02	b						
e- O		V2C0 GUPTA ET AL (1990)									
V	2000.0	6000.0	-0.36876460E+00-0.19261587E+04	0.72235159E+06	0.82699294E+01	b					
V	6000.0	15000.0	0.12858415E+00	0.88173340E+04-0.22555849E+08	0.27992711E+01	b					
e- O2		V2C0 GUPTA ET AL (1990)									
V	2000.0	6000.0	-0.12686144E+01-0.64961158E+04	0.37615998E+07	0.15676996E+02	b					
V	6000.0	15000.0	0.44642126E+01	0.65553833E+05-0.10919736E+09-0.43066392E+02	b						
F2		V2C2 SVEHLA (1962,1994)									
V	200.0	1000.0	0.61198519E	00-0.39647960E	02-0.17294474E	04	0.21237710E	01	a		
V	1000.0	5000.0	0.64406091E	00-0.58273377E	00-0.52243255E	04	0.18666294E	01	a		
C	200.0	1000.0	0.46767823E	00-0.26624115E	03	0.18169657E	05	0.36165585E	01	a	
C	1000.0	5000.0	-0.19981248E	00-0.25129092E	04	0.80775379E	06	0.96845049E	01	a	

TABLE E.2.—Continued.

H			V2C2	VANDERSLICE ET AL (1962)						
V	1000.0	5000.0			0.74226149E+00-0.40132865E+03	0.18554165E+06	0.46741844E-01	b		
V	5000.0	15000.0			0.87486623E+00-0.25022902E+04	0.70955048E+07	-0.93888455E+00	b		
C	1000.0	5000.0			0.74166119E+00-0.40487203E+03	0.18775642E+06	0.34843121E+01	b		
C	5000.0	15000.0			0.87447639E+00-0.25089452E+04	0.71081294E+07	0.24970991E+01	b		
H		H+	V2C0	CAPITELLI ET AL (1976)						
V	2000.0	8000.0			0.65497943E+00	0.43620326E+03-0.20032290E+06	-0.15933989E+01	b		
V	8000.0	15000.0			0.35775595E+00-0.56298406E+04	0.14552701E+08	0.16055465E+01	b		
H		H2	V2C0	TANG & WEI (1974) SVEHLA (1994)						
V	1000.0	5000.0			0.91735768E+00	0.22052887E+03-0.57464994E+05	-0.93741490E+00	b		
V	5000.0	15000.0			0.94056210E+00-0.17266834E+02	0.82707957E+06	-0.11228741E+01	b		
H		Li	V2C0	KRUPENIE ET AL (1963)						
V	1000.0	5000.0			0.88870800E+00	0.25460216E+03-0.71635951E+05	-0.24355021E+01	b		
V	5000.0	10000.0			0.96451195E+00	0.78151762E+03-0.44137515E+06	-0.31717326E+01	b		
H		N	V2C0	STALLCOP ET AL (1992b)						
V	1000.0	6000.0			0.75455738E+00-0.15697085E+03	0.97258456E+05	-0.48331565E-01	b		
V	6000.0	16000.0			0.15653364E+01	0.87404680E+04-0.12001036E+08	-0.82485581E+01	b		
H		N2	V2C0	STALLCOP ET AL (1992b)						
V	600.0	3000.0			0.10228384E+01	0.53349114E+03-0.11365313E+06	-0.23880331E+01	b		
V	3000.0	10000.0			0.13275932E+01	0.14701554E+04-0.14725296E+06	-0.51365002E+01	b		
H		O	V2C0	KRUPENIE ET AL (1963)						
V	1000.0	5000.0			0.85479480E+00	0.18680077E+03-0.46790687E+05	-0.11272657E+01	b		
V	5000.0	10000.0			0.88515794E+00	0.64127280E+02	0.63943230E+06	-0.13887887E+01	b	
HBr			V2C2	ZELEZNIK & SVEHLA (1970) SVEHLA (1994)						
V	300.0	1000.0			0.54286515E	00-0.32909036E 03	0.28143861E 05	0.29266732E 01	a	
V	1000.0	5000.0			0.61904039E	00-0.12370443E 03	-0.36461217E 05	0.22596924E 01	a	
C	300.0	1000.0			0.91269760E	00-0.15456150E 03	0.21177636E 05	-0.43914664E 00	a	
C	1000.0	5000.0			0.63722827E	00-0.35434488E 03	-0.16663585E 05	0.17013527E 01	a	
HCN			V2C2	ZELEZNIK & SVEHLA (1970) SVEHLA (1994)						
V	300.0	1000.0			0.94863717E	00-0.14891490E 03	0.15258721E 05	-0.72592817E 00	a	
V	1000.0	5000.0			0.57370725E	00-0.85239973E 03	0.17953641E 06	0.24032031E 01	a	
C	300.0	1000.0			0.11749061E	01-0.19100307E 03	0.15714065E 05	-0.13488014E 01	a	
C	1000.0	5000.0			0.50543688E	00-0.13891056E 04	0.28003144E 06	0.42095130E 01	a	
HCL			V2C2	SVEHLA (1994)						
V	300.0	1000.0			0.54302009E	00-0.27882979E 03	0.20927618E 05	0.25895500E 01	a	
V	1000.0	5000.0			0.62673906E	00-0.81516979E 02	-0.35869154E 05	0.18707238E 01	a	
C	300.0	1000.0			0.90670645E	00-0.13561693E 03	0.18563886E 05	0.60312859E-01	a	
C	1000.0	5000.0			0.62521138E	00-0.43742347E 03	0.28720932E 05	0.22964614E 01	a	
HF			V2C2	SVEHLA (1994)						
V	300.0	1000.0			0.81674828E	00-0.23635428E 03	0.22759084E 05	0.70625888E 00	a	
V	1000.0	5000.0			0.58742532E	00-0.55543347E 03	0.67637899E 05	0.25645661E 01	a	
C	300.0	1000.0			0.12590294E	01	0.11896441E 01	-0.47558763E 03	-0.19367617E 01	a
C	1000.0	5000.0			0.51518587E	00-0.14932469E 04	0.37482086E 06	0.43206676E 01	a	
HF		H6F6	V2C0	SVEHLA (1994)						
V	300.0	1000.0			0.52633473E	00-0.32896634E 03	0.26842682E 05	0.22132195E 01	a	
V	1000.0	5000.0			0.62213454E	00-0.10239431E 03	-0.38543254E 05	0.13902717E 01	a	
HI			V2C2	SVEHLA (1962)						
V	300.0	1000.0			0.53718504E	00-0.22504609E 03	0.12416876E 05	0.27888146E 01	a	
V	1000.0	5000.0			0.63448421E	00-0.33714923E 02	-0.34599137E 05	0.19723806E 01	a	
C	300.0	1000.0			0.83653272E	00-0.10434645E 03	0.90075923E 04	-0.38982280E 00	a	
C	1000.0	5000.0			0.65866010E	00-0.18846822E 03	-0.37866478E 05	0.96987360E 00	a	

TABLE E.2.—Continued.

H2		V3C3 ASSAEL ET AL (1986) SVEHLA (1994)									
V	200.0	1000.0	0.74553182E	00	0.43555109E	02-0.32579340E	04	0.13556243E	00	a	
V	1000.0	5000.0	0.96730605E	00	0.67931897E	03-0.21025179E	06-0.18251697E	01	a		
V	5000.0	15000.0	0.10126129E+01	0.14973739E+04-0.14428484E+07-0.23254928E+01	b						
C	200.0	1000.0	0.10059461E+01	0.27951262E+03-0.29792018E+05	0.11996252E+01	b					
C	1000.0	5000.0	0.10582450E+01	0.24875372E+03	0.11736907E+05	0.82758695E+00	b				
C	5000.0	15000.0	-0.22364420E+00-0.69650442E+04-0.77771313E+05	0.13189369E+02	b						
H2		H2O		V3C0 SVEHLA (1964)							
V	300.0	1000.0	0.60085490E	00-0.67691161E	02-0.21319326E	04	0.14199776E	01	a		
V	1000.0	5000.0	0.64550551E	00	0.10165601E	02-0.18735061E	05	0.10502885E	01	a	
V	5000.0	10000.0	0.66153255E+00	0.22389456E+03-0.37073622E+06	0.88511419E+00	b					
H2		N2		V3C0 SVEHLA (1994)							
V	300.0	1000.0	0.66038264E	00	0.35574798E	01-0.95778014E	03	0.70536614E	00	a	
V	1000.0	5000.0	0.62938039E	00-0.69072207E	02	0.19855881E	05	0.97133819E	00	a	
V	5000.0	8000.0	-0.77818660E-01-0.82764842E+04	0.11699769E+08	0.81689807E+01	b					
H2		O2		V3C0 SVEHLA (1994)							
V	300.0	1000.0	0.69018087E	00-0.23876092E	00-0.48432502E	04	0.66856355E	00	a		
V	1000.0	5000.0	0.69427291E	00-0.17583177E	02	0.58748504E	04	0.64692305E	00	a	
V	5000.0	10000.0	0.62089983E+00-0.78264233E+03	0.10864044E+07	0.13816401E+01	b					
H2O		V3C3 SENGERS & WATSON (1986) SVEHLA (1994)									
V	373.2	1073.2	0.50019557E+00-0.69712796E+03	0.88163892E+05	0.30836508E+01	b					
V	1073.2	5000.0	0.58988538E+00-0.53769814E+03	0.54263513E+05	0.23386375E+01	b					
V	5000.0	15000.0	0.64330087E+00-0.95668913E+02-0.37742283E+06	0.18125190E+01	b						
C	373.2	1073.2	0.10966389E+01-0.55513429E+03	0.10623408E+06-0.24664550E+00	b						
C	1073.2	5000.0	0.39367933E+00-0.22524226E+04	0.61217458E+06	0.58011317E+01	b					
C	5000.0	15000.0	-0.41858737E+00-0.14096649E+05	0.19179190E+08	0.14345613E+02	b					
H2O		N2		V3C0 SVEHLA (1994)							
V	300.0	1000.0	0.57304553E	00-0.14853813E	03	0.39029324E	04	0.23462780E	01	a	
V	1000.0	5000.0	0.64243064E	00	0.25018380E	01-0.36924430E	05	0.17567700E	01	a	
V	5000.0	10000.0	0.64420052E+00	0.10592615E+01-0.34300588E+05	0.17418827E+01	b					
H2O		O2		V3C0 SVEHLA (1994)							
V	300.0	1000.0	0.64727375E	00-0.42110733E	01-0.45255490E	04	0.16510807E	01	a		
V	1000.0	5000.0	0.65299406E	00-0.17723412E	02	0.50906530E	04	0.16154623E	01	a	
V	5000.0	10000.0	0.60614671E+00-0.45218012E+03	0.56149352E+06	0.20791053E+01	b					
H2S		V2C2 ZELENNIK & SVEHLA (1970) SVEHLA (1994)									
V	300.0	1000.0	0.54078516E	00-0.30304377E	03	0.24073168E	05	0.24952022E	01	a	
V	1000.0	5000.0	0.62320319E	00-0.98355396E	02-0.37061803E	05	0.17823252E	01	a		
C	300.0	1000.0	0.99442135E	00-0.19849376E	03	0.18380943E	05-0.19947763E	00	a		
C	1000.0	5000.0	0.60597875E	00-0.56357581E	03	0.67027311E	04	0.28605490E	01	a	
H6F6		V2C2 SVEHLA (1994)									
V	300.0	1000.0	0.59712969E	00-0.36775006E	03	0.38256100E	05	0.15811495E	01	a	
V	1000.0	5000.0	0.60263706E	00-0.23619918E	03-0.24765049E	05	0.14745761E	01	a		
C	300.0	1000.0	0.82019209E	00-0.29783007E	03	0.17372752E	05	0.94706680E	00	a	
C	1000.0	5000.0	0.53249125E	00-0.75921725E	03	0.10421649E	06	0.33089772E	01	a	
He		V3C3 BICH ET AL (1990)									
V	200.0	1000.0	0.75015944E	00	0.35763243E	02-0.22121291E	04	0.92126352E	00	a	
V	1000.0	5000.0	0.83394166E	00	0.22082656E	03-0.52852591E	05	0.20809361E	00	a	
V	5000.0	15000.0	0.86316349E+00	0.96205176E+03-0.12498705E+07-0.14115714E+00	b						
C	200.0	1000.0	0.75007833E	00	0.36577987E	02-0.23636600E	04	0.29766475E	01	a	
C	1000.0	5000.0	0.83319259E	00	0.22157417E	03-0.53304530E	05	0.22684592E	01	a	
C	5000.0	15000.0	0.85920953E+00	0.89873206E+03-0.11069262E+07	0.19535742E+01	b					
He		N2		V3C0 SVEHLA (1994)							
V	300.0	1000.0	0.70332377E	00	0.77412205E	01-0.17715400E	04	0.11440787E	01	b	
V	1000.0	5000.0	0.66785742E	00-0.84659628E	02	0.26695708E	05	0.14530051E	01	b	
V	5000.0	15000.0	0.16804077E+01	0.15615203E+05-0.28112833E+08-0.91877596E+01	b						

TABLE E.2.—Continued.

I2			V2C2	SVEHLA (1962)						
V	300.0	1000.0	0.54929498E	00-0.36186119E	03	0.33655931E	05	0.26154108E	01 a	
V	1000.0	5000.0	0.61338027E	00-0.15938416E	03-0.	35539572E	05	0.20394438E	01 a	
C	300.0	1000.0	0.29817264E	00-0.62470054E	03	0.63289228E	05	0.30234067E	01 a	
C	1000.0	5000.0	-0.15544742E	00-0.28843448E	04	0.96629457E	06	0.75135419E	01 a	
Kr			V3C3	BICH ET AL (1990)						
V	200.0	1000.0	0.58597795E	00-0.12924832E	03	0.47495759E	04	0.25793650E	01 a	
V	1000.0	5000.0	0.68985845E	00	0.56296306E	02-0.	36082600E	05	0.17170715E	01 a
V	5000.0	15000.0	0.76582939E+00	0.68610377E+03-0.	82537190E+06	0.97565128E+00			b	
C	200.0	1000.0	0.58008139E	00-0.13792556E	03	0.60771460E	04	0.16420039E	01 a	
C	1000.0	5000.0	0.68859431E	00	0.51765647E	02-0.	34512131E	05	0.74332130E	00 a
C	5000.0	15000.0	0.76365443E+00	0.65175847E+03-0.	73589800E+06	0.12112126E-01			b	
Li			V2C2	HOLLAND ET AL (1986)						
V	1000.0	3000.0	0.11808900E+01	0.10427008E+04-0.	42642819E+06-0.	40060038E+01			b	
V	3000.0	10000.0	0.13061758E+01	0.10446775E+04	0.13439272E+06-0.	50720601E+01			b	
C	1000.0	3000.0	0.11802957E+01	0.10408710E+04-0.	42655445E+06-0.	24982084E+01			b	
C	3000.0	10000.0	0.13086032E+01	0.10695497E+04	0.10781083E+06-0.	35944181E+01			b	
N			V2C2	LEVIN ET AL (1990)						
V	1000.0	5000.0	0.83724737E+00	0.43997150E+03-0.	17450753E+06	0.10365689E+00			b	
V	5000.0	15000.0	0.89986588E+00	0.14112801E+04-0.	18200478E+07-0.	55811716E+00			b	
C	1000.0	5000.0	0.83771661E+00	0.44243270E+03-0.	17578446E+06	0.89942915E+00			b	
C	5000.0	15000.0	0.90001710E+00	0.14141175E+04-0.	18262403E+07	0.24048513E+00			b	
N		N+	V2C0	STALLCOP ET AL (1991)						
V	1000.0	5000.0	0.81904143E+00-0.	59239089E+02	0.21722555E+05-0.	14759287E+00			b	
V	5000.0	15000.0	0.14065434E+01	0.52447258E+04-0.	58944155E+07-0.	59756079E+01			b	
N		NO	V2C0	CUBLEY & MASON (1975)						
V	1000.0	5000.0	0.79891098E+00	0.16929386E+03-0.	49068896E+05	0.47986716E+00			b	
V	5000.0	15000.0	0.85695322E+00	0.70223546E+03-0.	65589491E+06-0.	96805084E-01			b	
N		N2	V2C0	CUBLEY & MASON (1975)						
V	1000.0	5000.0	0.84730498E+00	0.22158858E+03-0.	65003723E+05	0.51991532E-01			b	
V	5000.0	15000.0	0.92821273E+00	0.97122155E+03-0.	92773923E+06-0.	75253261E+00			b	
N		O	V2C0	LEVIN ET AL (1990)						
V	1000.0	5000.0	0.70857405E+00-0.	14025530E+03	0.76739975E+05	0.13001914E+01			b	
V	5000.0	15000.0	0.98622236E+00	0.23653200E+04-0.	27165945E+07-0.	14539746E+01			b	
N		O+	V2C0	PARTRIDGE ET AL (1991)						
V	1000.0	5000.0	0.71806621E+00-0.	22692123E+03	0.63051343E+03	0.88739853E+00			b	
V	5000.0	15000.0	0.12913413E+01	0.49522731E+04-0.	57814165E+07-0.	47998532E+01			b	
N		O2	V2C0	CUBLEY & MASON (1975)						
V	1000.0	5000.0	0.76538325E+00	0.13624746E+03-0.	39083438E+05	0.80110069E+00			b	
V	5000.0	15000.0	0.81011289E+00	0.54373468E+03-0.	49868094E+06	0.35701613E+00			b	
N+		O	V2C0	PARTRIDGE ET AL (1991)						
V	1000.0	5000.0	0.11462863E+01	0.12410378E+04-0.	56794094E+06-0.	29071183E+01			b	
V	5000.0	15000.0	0.10155522E+01-0.	32731184E+03	0.17187573E+07-0.	15714289E+01			b	
NH3			V2C2	ZELEZNIK & SVEHLA (1970)		SVEHLA (1994)				
V	200.0	1000.0	0.56652403E	00-0.36718083E	03	0.31663844E	05	0.22647443E	01 a	
V	1000.0	5000.0	0.59761003E	00-0.28027339E	03	0.37532457E	04	0.19910129E	01 a	
C	200.0	1000.0	0.17498387E	01	0.29195254E	03-0.	33033738E	05-0.	50944985E	01 a
C	1000.0	5000.0	0.64477673E	00-0.91294723E	03	0.16890182E	05	0.36939751E	01 a	
NO			V3C3	BOUSHEHRI ET AL (1987)		SVEHLA (1994)				
V	200.0	1000.0	0.60262029E	00-0.62017783E	02-0.	13954524E	03	0.20268332E	01 a	
V	1000.0	5000.0	0.78009050E	00	0.30486891E	03-0.	94847722E	05	0.52873381E	00 a
V	5000.0	15000.0	0.80580582E+00	0.62427878E+03-0.	57879210E+06	0.26516450E+00			b	
C	200.0	1000.0	0.95028758E+00	0.76667058E+02-0.	99894764E+04-0.	62776717E-02			b	
C	1000.0	5000.0	0.86215238E+00	0.44568223E+03-0.	23856466E+06	0.46209876E+00			b	
C	5000.0	15000.0	-0.10377865E+01-0.	34486864E+05	0.67451187E+08	0.20928749E+02			b	

TABLE E.2.—Continued.

NO	O	V2C0 CUBLEY & MASON (1975)				
V 1000.0	5000.0	0.75990752E+00	0.13133851E+03	-0.37679635E+05	0.87807540E+00	b
V 5000.0	15000.0	0.80259080E+00	0.51991196E+03	-0.47557226E+06	0.45433467E+00	b
NOCL		V2C2 SVEHLA (1994)				
V 300.0	1000.0	0.60503640E	00-0.30599542E	03 0.28616290E	05 0.20637208E	01 a
V 1000.0	5000.0	0.60958727E	00-0.19972327E	03-0.22243863E	05 0.19768724E	01 a
C 300.0	1000.0	0.52036442E	00-0.53758642E	03 0.52600561E	05 0.29380096E	01 a
C 1000.0	5000.0	0.92835992E	00 0.13511240E	03-0.79751817E	05-0.42066992E	00 a
NO2		V2C2 SVEHLA (1966)				
V 300.0	1000.0	0.57379100E	00-0.12636034E	03 0.21566823E	04 0.22287492E	01 a
V 1000.0	5000.0	0.64239645E	00 0.60012144E	00-0.27020876E	05 0.16570566E	01 a
C 300.0	1000.0	0.48574998E	00-0.50702110E	03 0.46605820E	05 0.36444556E	01 a
C 1000.0	5000.0	0.97660465E	00 0.72760751E	03-0.32527989E	06-0.60899123E	00 a
N2		V3C3 BOUSHEHRI ET AL (1987) SVEHLA (1994)				
V 200.0	1000.0	0.62526577E	00-0.31779652E	02-0.16407983E	04 0.17454992E	01 a
V 1000.0	5000.0	0.87395209E	00 0.56152222E	03-0.17394809E	06-0.39335958E	00 a
V 5000.0	15000.0	0.88503551E+00	0.90902171E+03	-0.73129061E+06	-0.53503838E+00	b
C 200.0	1000.0	0.85439436E+00	0.10573224E+03	-0.12347848E+05	0.47793128E+00	b
C 1000.0	5000.0	0.88407146E+00	0.13357293E+03	-0.11429640E+05	0.24417019E+00	b
C 5000.0	15000.0	0.24176185E+01	0.80477749E+04	0.31055802E+07	-0.14517761E+02	b
N2	O	V2C0 CUBLEY & MASON (1975)				
V 1000.0	5000.0	0.79176378E+00	0.16226176E+03	-0.47001647E+05	0.58989646E+00	b
V 5000.0	15000.0	0.84676036E+00	0.66685159E+03	-0.62101896E+06	0.43522696E-01	b
N2	O2	V3C0 SVEHLA (1994)				
V 300.0	1000.0	0.70122551E	00 0.51717887E	01-0.14240838E	04 0.12895991E	01 a
V 1000.0	5000.0	0.66744478E	00-0.86348036E	02 0.27445341E	05 0.15855986E	01 a
V 5000.0	15000.0	0.21151565E+00	-0.91881544E+04	0.18253525E+08	0.65600002E+01	b
N2O		V2C2 BOUSHEHRI ET AL (1987) URIBE ET AL (1990)				
V 200.0	1000.0	0.58959112E	00-0.15565178E	03 0.37630431E	04 0.21223853E	01 a
V 1000.0	5000.0	0.64571469E	00-0.88806585E	01-0.41560559E	05 0.16332498E	01 a
C 200.0	1000.0	0.65165376E	00-0.34373058E	03 0.15090399E	05 0.24242359E	01 a
C 1000.0	5000.0	0.64720604E	00-0.78680195E	02-0.11965729E	06 0.23246569E	01 a
N2O4		V2C2 SVEHLA (1966)				
V 300.0	1000.0	0.52508683E	00-0.28652689E	03 0.20354406E	05 0.25287873E	01 a
V 1000.0	5000.0	0.62841605E	00-0.65798081E	02-0.38345315E	05 0.16529852E	01 a
C 300.0	1000.0	0.33364942E	00-0.68702644E	03 0.52625318E	05 0.47685793E	01 a
C 1000.0	5000.0	0.59441359E	00-0.26239268E	03-0.29309960E	05 0.26245858E	01 a
Na		V2C2 HOLLAND & BIOLSI (1987)				
V 500.0	2000.0	0.91803855E+00	0.22790517E+03	-0.63721828E+05	-0.12813410E+01	b
V 2000.0	10000.0	0.11882599E+01	0.48628768E+03	0.21833835E+06	-0.35349734E+01	b
C 500.0	2000.0	0.91834808E+00	0.22837346E+03	-0.63906051E+05	-0.97901956E+00	b
C 2000.0	10000.0	0.11900946E+01	0.49842922E+03	0.20953120E+06	-0.32479254E+01	b
Ne		V3C3 BICH ET AL (1990)				
V 200.0	1000.0	0.68398511E	00 0.18732366E	02-0.23663189E	04 0.18284755E	01 a
V 1000.0	5000.0	0.72333495E	00 0.10420872E	03-0.25429545E	05 0.14942434E	01 a
V 5000.0	15000.0	0.77549350E+00	0.59414850E+03	-0.69670786E+06	0.97885712E+00	b
C 200.0	1000.0	0.68509965E	00 0.19794924E	02-0.24525539E	04 0.22586136E	01 a
C 1000.0	5000.0	0.72278122E	00 0.10528290E	03-0.26355706E	05 0.19367337E	01 a
C 5000.0	15000.0	0.77589413E+00	0.61283778E+03	-0.74015705E+06	0.14114011E+01	b
O		V2C2 LEVIN ET AL (1990)				
V 1000.0	5000.0	0.77269241E+00	0.83842977E+02	-0.58502098E+05	0.85100827E+00	b
V 5000.0	15000.0	0.87669586E+00	0.10158420E+04	-0.10884566E+07	-0.18001077E+00	b
C 1000.0	5000.0	0.77271664E+00	0.83989100E+02	-0.58580966E+05	0.15179900E+01	b
C 5000.0	15000.0	0.87676666E+00	0.10170744E+04	-0.10906690E+07	0.48644232E+00	b

TABLE E.2.—Concluded.

O	O+	V2C0 STALLCOP ET AL (1991)				
V 1000.0	5000.0	0.96270522E+00	0.57916036E+03	-0.28549938E+06	-0.12297154E+01	b
V 5000.0	15000.0	0.99113919E+00	-0.80815595E+02	0.17198651E+07	-0.14201124E+01	b
O	O2	V2C0 CUBLEY & MASON (1975)				
V 1000.0	5000.0	0.73493993E+00	0.10911663E+03	-0.31057767E+05	0.10998186E+01	b
V 5000.0	15000.0	0.76924754E+00	0.42004937E+03	-0.37954441E+06	0.75936688E+00	b
OH		V2C2 SVEHLA (1994)				
V 1000.0	5000.0	0.59711536E+00	-0.46100678E+03	0.37606286E+05	0.24041761E+01	b
V 5000.0	15000.0	0.64287721E+00	-0.18173747E+03	-0.88543767E+05	0.19636057E+01	b
C 1000.0	5000.0	0.68627561E+00	-0.74033274E+03	0.27559033E+05	0.28308741E+01	b
C 5000.0	15000.0	-0.47918112E+00	-0.93769908E+04	0.70509952E+07	0.14203688E+02	b
O2		V3C3 BOUSHEHRI ET AL (1987) SVEHLA (1994)				
V 200.0	1000.0	0.60916180E 00	-0.52244847E 02	-0.59974009E 03	0.20410801E 01	a
V 1000.0	5000.0	0.72216486E 00	0.17550839E 03	-0.57974816E 05	0.10901044E 01	a
V 5000.0	15000.0	0.73981127E+00	0.39194906E+03	-0.37833168E+06	0.90931780E+00	b
C 200.0	1000.0	0.77229167E+00	0.68463210E+01	-0.58933377E+04	0.12210365E+01	b
C 1000.0	5000.0	0.90917351E+00	0.29124182E+03	-0.79650171E+05	0.64851631E-01	b
C 5000.0	15000.0	-0.11218262E+01	-0.19286378E+05	0.23295011E+08	0.20342043E+02	b
SF6		V2C2 BOUSHEHRI ET AL (1987) SVEHLA (1994)				
V 300.0	1000.0	0.49748474E 00	-0.21864084E 03	0.14509989E 05	0.27631958E 01	a
V 1000.0	5000.0	0.60769589E 00	-0.14230978E 03	0.31449312E 05	0.19086137E 01	a
C 300.0	1000.0	0.41857258E 00	-0.19733612E 03	-0.25661949E 05	0.34555207E 01	a
C 1000.0	5000.0	0.60633905E 00	0.44458129E 02	-0.52676509E 05	0.19436963E 01	a
SO2		V2C2 ZELEZNIK & SVEHLA (1970) SVEHLA (1994)				
V 300.0	1000.0	0.53157084E 00	-0.29589873E 03	0.21224840E 05	0.25975549E 01	a
V 1000.0	5000.0	0.60783098E 00	-0.19283581E 03	0.78232002E 04	0.19811072E 01	a
C 300.0	1000.0	0.61476551E 00	-0.56409295E 03	0.49580787E 05	0.23940064E 01	a
C 1000.0	5000.0	0.53617558E 00	-0.69413085E 03	0.75304908E 05	0.30412002E 01	a
SiCL4		V2C2 SVEHLA (1994)				
V 300.0	1000.0	0.52724861E 00	-0.26992512E 03	0.18062726E 05	0.22413435E 01	a
V 1000.0	5000.0	0.63025696E 00	-0.55616232E 02	-0.37587506E 05	0.13711284E 01	a
C 300.0	1000.0	0.48928637E 00	-0.34031669E 03	0.15336652E 05	0.23608171E 01	a
C 1000.0	5000.0	0.62189282E 00	-0.14644974E 03	-0.15293955E 05	0.12815679E 01	a
SiF4		V2C2 SVEHLA (1962,1994)				
V 300.0	1000.0	0.59609697E 00	-0.79178529E 02	-0.15915012E 04	0.19580540E 01	a
V 1000.0	5000.0	0.64527457E 00	0.10348180E 02	-0.21766101E 05	0.15489951E 01	a
C 300.0	1000.0	0.44281914E 00	-0.38082561E 03	0.16794039E 05	0.35456135E 01	a
C 1000.0	5000.0	0.62544021E 00	-0.11192686E 03	-0.26345285E 05	0.20583524E 01	a
SiH4		V2C2 SVEHLA (1962)				
V 300.0	1000.0	0.57519423E 00	-0.12326162E 03	0.18824028E 04	0.18761319E 01	a
V 1000.0	5000.0	0.64257687E 00	0.12846016E 01	-0.26699436E 05	0.13147047E 01	a
C 300.0	1000.0	0.55408670E 00	-0.64339630E 03	0.55747611E 05	0.37641386E 01	a
C 1000.0	5000.0	0.56234379E 00	-0.44931035E 03	-0.37165926E 05	0.36059282E 01	a
UF6		V2C0 SVEHLA (1962)				
V 300.0	1000.0	0.56019928E 00	-0.15978215E 03	0.52866529E 04	0.24249812E 01	a
V 1000.0	5000.0	0.63981806E 00	-0.95366264E 01	-0.30026765E 05	0.17600620E 01	a
Xe		V3C3 BICH ET AL (1990)				
V 200.0	1000.0	0.57988418E 00	-0.18806666E 03	0.10508723E 05	0.26502107E 01	a
V 1000.0	5000.0	0.68506945E 00	0.47671749E 02	-0.54767718E 05	0.17531546E 01	a
V 5000.0	15000.0	0.75436414E+00	0.69100248E+03	-0.75140593E+06	0.10621747E+01	b
C 200.0	1000.0	0.57308328E 00	-0.19991432E 03	0.12872027E 05	0.12718931E 01	a
C 1000.0	5000.0	0.68319650E 00	0.40020092E 02	-0.52038474E 05	0.33623407E 00	a
C 5000.0	15000.0	0.75593640E+00	0.72923858E+03	-0.82407834E+06	-0.39025477E+00	b
end						

a. Svehla, R.A., 1995, "Transport Coefficients for the NASA Lewis Chemical Equilibrium Program," NASA TM-4647.

b. Svehla, R.A., 1996, Private communication.

Appendix F

COMMON Variables Used in Equilibrium Module

This appendix contains two tables. Table F.1 is entitled “COMMON Variables That Must Be Initialized Before Entering Equilibrium Module”. It gives the following information:

1. The name of the variable
2. Its dimension
3. The type of variable, such as R*8 or L*4
4. The COMMON label
5. The subroutine where the variable is set
6. Whether the variable can be reset within the module
7. Information describing the variable, such as its symbol and the equation number in Gordon and McBride (1994)

Table F.2, entitled “COMMON Variables Calculated by Equilibrium Module”, gives information similar to that described above.

TABLE F.1.—COMMON VARIABLES THAT MUST BE INITIALIZED
BEFORE ENTERING EQUILIBRIUM MODULE

Variable	Dimension	Type	COMMON label	Where set	Reset?	Description (symbols and equations from Gordon and McBride, 1994)
A	MAXEL, MAXNGC	R*8	MISCR	SEARCH	Yes	a_{ij} , eq. (2.7a)
Atwt	MAXEL	R*8	MISCR	REACT SEARCH	Yes	Atomic weight of elements
B0	MAXEL	R*8	MISCR	NEWOF	Yes	b_i^0 , eq. (9.5)
B0p	MAXEL, 2	R*8	INPT	REACT	Yes	$b_i^{(k)}$, eq. (9.1)
Bratio	-----	R*4	INPT	NEWOF	No	Bratio is discussed in sec. 3.2.
Cft	MAXNC, 9	R*8	THERM	SEARCH	No	a_{ij} , eqs. (4.9) to (4.11) for condensed species and each temperature interval
Coef	MAXNG, 9, 3	R*8	THERM	SEARCH	No	a_{ij} , eqs. (4.9) to (4.11) for gases and three temperature intervals
Debug	NCOL	L*4	MISCL	INPUT	No	If true, print intermediate output for output column number Npt.
Elmt	MAXEL	C*2	CDATA	REACT	Yes	Element chemical symbol
En	MAXNGC, NCOL	R*8	COMP	Main SETEN	Yes	n_i , eq. (2.2); second index is Npt
Enln	MAXNGC	R*8	COMP	Main SETEN	Yes	$\ln n_i$
Enn	-----	R*8	COMP	Main SETEN	Yes	n , eq. (2.1a)
Enn1	-----	R*8	COMP	Main SETEN	Yes	$\ln n$
Gonly	-----	L*4	MISCL	Main	Yes	If true, all product species are gaseous.
Hp	-----	L*4	MISCL	Main DETON INPUT ROCKET SHCK THERMP	No	If true, either enthalpy and pressure or internal energy and volume (or density) have been assigned.
Hsub0	-----	R*8	MISCR	DETON HCALC NEWOF INPUT SHCK	No	$h_{0i}R$, assigned specific enthalpy of mixture divided by universal gas constant, eq. (9.7)
Ifz	MAXNC	I*4	INDX	REACT SEARCH	No	Positive integer numbering condensed phases of a species starting with 1 and increasing with temperature ranges
Ions	-----	L*4	MISCL	INPUT	No	If true, ionic species are to be considered.
Jcm	MAXEL	I*4	TRNP	SEARCH	Yes	Indices of species currently used as components (usually monatomic gases)
Jcond	45	I*4	INDX	Main SETEN	Yes	Indices of condensed species currently being considered

TABLE F.1.—Continued.

Variable	Dimension	Type	COMMON label	Where set	Reset?	Description (symbols and equations from Gordon and McBride, 1994)
Jliq	-----	I*4	MISCI	NEWOF SETEN	Yes	Index of condensed species that is included simultaneously with another condensed phase of same species. Jsol is for the adjacent species; Jliq is for the higher temperature interval.
Jsol	-----	I*4	MISCI	NEWOF SETEN	Yes	See Jliq.
Jx	MAXEL	I*4	INDX	SEARCH	Yes	Indices of monatomic gases
Lsave	-----	I*4	MISCI	INPUT SETEN	Yes	0 when processing input; Nlm+1 in EQLBRM after convergence when ionic species are included as products, and Nlm when they are not
Mw	MAXNGC	R*8	THERM	HCALC SEARCH	No	Molecular weight of product species
Nc	-----	I*4	INDX	SEARCH	No	Number of temperature intervals for all possible condensed products for current problem
Ng	-----	I*4	INDX	SEARCH	Yes	Number of possible gaseous products for current problem
Ngc	-----	I*4	INDX	SEARCH	No	Ng+Nc
Ngpl	-----	I*4	INDX	SEARCH	No	Ng+1
Nlm	-----	I*4	INDX	Main	Yes	Number of elements in current chemical system
Npr	-----	I*4	INDX	REACT Main	Yes	Number of condensed species currently being considered
Npt	-----	I*4	INDX	SEARCH DETON NEWOF ROCKET SHCK THERMP	No	Index of column for data saved for output ($1 \leq Npt \leq NCOL$)
NspX	-----	I*4	INDX	SEARCH	No	Ngc plus number of monatomic gases without thermo data
Pp	-----	R*8	MISCR	DETON ROCKET SHCK THERMP	Yes	Assigned pressure in bars for current point
Prod	0:MAXNGC	C*15	CDATA	SEARCH	No	Species names
Rc	-----	R*8	MISCR	BLOCKDATA	No	Universal gas constant, 8314.51 J/(kg-mol)K
S0	-----	R*8	MISCR	INPUT ROCKET	No	s_0/R , assigned specific entropy of mixture divided by universal gas constant
Shock	-----	L*4	MISCL	INPUT	No	If true, shock problem.
Short	-----	L*4	MISCL	INPUT	No	If true, listed output is abbreviated.
Size	-----	R*8	MISCR	INPUT NEWOF	Yes	SIZE as discussed in sec. 3.2 of Gordon and McBride (1994)
Sp	-----	L*4	MISCL	INPUT ROCKET	No	If true, entropy and pressure (or volume) have been assigned.
Sumn	-----	R*8	COMP	Main SETEN	Yes	Value of summation in eq. (2.2)
Temp	2,MAXNC	R*8	THERM	SEARCH	No	Temperature ranges for thermodynamic properties of all condensed products

TABLE F.1.—Concluded.

Variable	Dimension	Type	COMMON label	Where set	Reset?	Description (symbols and equations from Gordon and McBride, 1994)
Tg	4	R*8	THERM	SEARCH	No	Temperature ranges for thermodynamic properties of gases
Tp	-----	L*4	MISCL	DETON INPUT ROCKET SHCK	No	If true, temperature and pressure (or volume) have been assigned.
Trace	-----	R*8	MISCR	INPUT SHCK	No	If Trace>0, print mole (or mass) fractions \geq Trace in special E-format
Tt	-----	R*8	MISCR	DETON ROCKET SETEN SHCK THERMP	Yes	Current temperature in kelvin
Vol	-----	L*4	MISCL	INPUT	No	If true, volume has been assigned.
Vv	-----	R*8	MISCR	THERMP	No	Assigned specific volume times 10^{-5} , (m ³ /kg) 10^{-5} , eq. (2.1a)

TABLE F.2.—COMMON VARIABLES CALCULATED BY EQUILIBRIUM MODULE

Variable	Dimension	Type	COMMON label	Where set	Description (symbols and equations from Gordon and McBride, 1994)
Cp	MAXNGC	R*8	THERM	CPHS	Molar heat capacity for species divided by universal gas constant, eq. (4.9)
Cpr	NCOL	R*8	PRTOUT	EQLBRM	Specific heat of mixture divided by universal gas constant, eq. (2.59)
Divpt	NCOL	R*8	PRTOUT	EQLBRM	Derivative defined by eq. (2.51)
Divvp	NCOL	R*8	PRTOUT	EQLBRM	Derivative defined by eq. (2.50)
Gammas	NCOL	R*8	PRTOUT	EQLBRM	Isentropic exponent, eqs. (2.71)
H0	MAXNGC	R*8	THERM	CPHS	Molar standard-state enthalpy of species divided by universal gas constant, eq. (4.10)
Hsum	NCOL	R*8	PRTOUT	MATRIX	Specific enthalpy of mixture divided by universal gas constant, eq. (2.14)
Mu	MAXNGC	R*8	THERM	MATRIX	Molar Gibbs energy for each species
Ppp	NCOL	R*8	PRTOUT	EQLBRM	Static pressure in bars stored for output
S	MAXNGC	R*8	THERM	CPHS	Molar standard-state entropy of species divided by universal gas constant, eq. (4.11)
Ssum	NCOL	R*8	PRTOUT	EQLBRM	Specific entropy of mixture divided by universal gas constant, eq. (2.16)
Totn	NCOL	R*8	PRTOUT	EQLBRM	Totn(i)=sum of En(j,Npt) for all species, denominator of eq. (2.4a)
Ttt	NCOL	R*8	PRTOUT	EQLBRM	Temperature in kelvin stored for output
Vlm	NCOL	R*8	PRTOUT	EQLBRM	Specific volume times 10^{-5} , (m ³ /kg) 10^{-5} , eq. (2.1a)
Wm	NCOL	R*8	PRTOUT	EQLBRM	Molecular weight of mixture, eq. (2.3a)

Appendix G

Example Problems

This appendix presents the output for the example problems discussed in chapter 7.

NASA-LEWIS CHEMICAL EQUILIBRIUM PROGRAM CEA, MARCH 1996
BY BONNIE MCBRIDE AND SANFORD GORDON
REFS: NASA RP-1311, PART I, 1994 AND NASA RP-1311, PART II, 1996

SAMPLE PROBLEMS

! EXAMPLE 1:
! (a) Assigned-temperature-and-pressure problem (tp).
! (b) Reactants are H2 and Air. Since "exploded" formulas are not given,
! these formulas will be taken from the thermodynamic data library,
! thermo.lib.
! (c) Calculations are for two equivalence ratios (r,eq.ratio =1,1.5).
! (d) Assigned pressures are 1, 0.1, and 0.01 atm (p(atm)=1,.1,.01).
! (e) Assigned temperatures are 3000 and 2000 K (t(k)=3000,2000).
! (f) 'only' dataset is used to restrict possible products.
! (g) Energy units in the final tables are in calories (calories).

! 'problem' dataset:
problem case=Example-1 tp p(atm)=1,.1,.01,t(k)=3000,2000,
r,eq.ratio=1,1.5

! 'reactants' dataset:
react
fuel= H2 moles = 1.
oxid= Air moles = 1.

! 'only' dataset:
only Ar C CO CO2 H H2 H2O HNO HO2 HNO2 HNO3 N NH
NO N2 N2O3 O O2 OH O3

! 'output' dataset:
output calories

! 'end' dataset
end

OPTIONS: TP=T HP=F SP=F TV=F UV=F SV=F DETN=F SHOCK=F REFL=F INCD=F
RKT=F FROZ=F EQL=F IONS=F SIUNIT=F DEBUGF=F SHKDBG=F DETDBG=F TRNSPT=F

T,K = 3000.0000 2000.0000

TRACE= 0.00E+00 S/R= 0.000000E+00 H/R= 0.000000E+00 U/R= 0.000000E+00

P,BAR = 1.013250 0.101325 0.010132

REACTANT	MOLES	(ENERGY/R),K	TEMP,K	DENSITY
EXPLODED FORMULA				
F: H2	1.000000	0.000000E+00	0.00	0.0000
H	2.000000			
O: Air	1.000000	0.000000E+00	0.00	0.0000
N	1.56170	O 0.41959	AR 0.00937	C 0.00032

SPECIES BEING CONSIDERED IN THIS SYSTEM
(CONDENSED PHASE MAY HAVE NAME LISTED SEVERAL TIMES)

1 6/88 *Ar	111/88 *C	tpis79 *CO
1 7/88 *CO2	1 6/94 *H	112/89 HNO
tpis89 HNO2	1 4/90 HNO3	1 5/89 HO2
tpis78 *H2	1 8/89 H2O	1 6/88 *N
111/89 *NH	tpis89 *NO	tpis78 *N2
1 4/90 N2O3	1 1/90 *O	tpis78 *OH
tpis89 *O2	1 5/90 O3	

O/F = 34.297046

ENTHALPY (KG-MOL) (K)/KG	EFFECTIVE FUEL h(2)/R	EFFECTIVE OXIDANT h(1)/R	MIXTURE h0/R
	0.00000000E+00	0.00000000E+00	0.00000000E+00
KG-FORM.WT./KG	bi(2)	bi(1)	b0i
*H	0.99212255E+00	0.00000000E+00	0.28107807E-01
*N	0.00000000E+00	0.53915548E-01	0.52388068E-01
*O	0.00000000E+00	0.14485769E-01	0.14075373E-01
*Ar	0.00000000E+00	0.32348639E-03	0.31432170E-03
*C	0.00000000E+00	0.11047560E-04	0.10734572E-04

POINT	ITN	T	H	N	O	AR
		C				
1	13	3000.000	-11.767	-14.452	-17.112	-27.077
		-25.140				
2	6	2000.000	-12.631	-13.684	-17.810	-26.104
		-28.010				
3	5	3000.000	-12.811	-15.668	-18.090	-29.507
		-26.387				
4	7	2000.000	-13.414	-14.837	-18.560	-28.409
		-28.858				
5	6	3000.000	-14.310	-16.920	-19.495	-32.012
		-27.378				
6	8	2000.000	-14.202	-15.991	-19.318	-30.716
		-29.736				

THERMODYNAMIC EQUILIBRIUM PROPERTIES AT ASSIGNED

TEMPERATURE AND PRESSURE

CASE = Example-1

	REACTANT	MOLES	ENERGY CAL/MOL	TEMP K
FUEL	H2	1.0000000	0.000	0.000
OXIDANT	Air	1.0000000	0.000	0.000

O/F= 34.29705 %FUEL= 2.833098 R,EQ.RATIO= 1.000000 PHI, EQ.RATIO= 1.000000

THERMODYNAMIC PROPERTIES

P, ATM	1.0000	1.0000	0.10000	0.10000	0.01000	0.01000
T, K	3000.00	2000.00	3000.00	2000.00	3000.00	2000.00
RHO, G/CC	9.1864-5	1.4990-4	8.0877-6	1.4957-5	6.6054-7	1.4878-6
H, CAL/G	658.91	-203.80	1367.61	-192.33	2655.92	-165.41
U, CAL/G	395.29	-365.35	1068.18	-354.25	2289.29	-328.19
G, CAL/G	-7973.51	-5290.34	-8615.20	-5662.69	-9379.92	-6036.36
S, CAL/(G) (K)	2.8775	2.5433	3.3276	2.7352	4.0119	2.9355
M, (1/n)	22.615	24.601	19.910	24.547	16.261	24.417
(dLV/dLP)t	-1.03437	-1.00062	-1.07935	-1.00143	-1.07486	-1.00352
(dLV/dLT)p	1.6948	1.0200	2.5468	1.0452	2.4145	1.1090
Cp, CAL/(G) (K)	1.6795	0.4539	3.4666	0.5187	3.7240	0.6801
GAMMAS	1.1311	1.2263	1.1203	1.2035	1.1318	1.1677
SON VEL, M/SEC	1117.0	910.4	1184.7	902.9	1317.6	891.8

MOLE FRACTIONS

*Ar	0.00711	0.00773	0.00626	0.00772	0.00511	0.00767
*CO	0.00017	0.00001	0.00018	0.00002	0.00017	0.00004
*CO2	0.00007	0.00025	0.00003	0.00024	0.00001	0.00022
*H	0.04069	0.00009	0.14315	0.00041	0.31984	0.00185
HO2	0.00001	0.00000	0.00001	0.00000	0.00000	0.00000
*H2	0.06708	0.00304	0.08301	0.00633	0.04144	0.01309
H2O	0.20936	0.34216	0.09741	0.33736	0.01193	0.32683
*N	0.00001	0.00000	0.00003	0.00000	0.00009	0.00000
*NO	0.01247	0.00049	0.01389	0.00073	0.00974	0.00108
*N2	0.58613	0.64416	0.51456	0.64261	0.42102	0.63903
*O	0.01560	0.00002	0.05864	0.00010	0.14381	0.00047
*OH	0.04205	0.00100	0.05562	0.00216	0.03048	0.00460
*O2	0.01925	0.00104	0.02721	0.00232	0.01637	0.00510

* THERMODYNAMIC PROPERTIES FITTED TO 20000.K

PRODUCTS WHICH WERE CONSIDERED BUT WHOSE MOLE FRACTIONS
WERE LESS THAN 5.000000E-06 FOR ALL ASSIGNED CONDITIONS

*C	HNO	HNO2	HNO3	*NH
N2O3	O3			

O/F = 22.853060

ENTHALPY (KG-MOL) (K)/KG	EFFECTIVE FUEL h(2)/R	EFFECTIVE OXIDANT h(1)/R	MIXTURE h0/R
	0.00000000E+00	0.00000000E+00	0.00000000E+00
KG-FORM. WT. /KG	bi(2)	bi(1)	b0i
*H	0.99212255E+00	0.00000000E+00	0.41593093E-01
*N	0.00000000E+00	0.53915548E-01	0.5165228E-01
*O	0.00000000E+00	0.14485769E-01	0.13878477E-01
*Ar	0.00000000E+00	0.32348639E-03	0.30992476E-03
*C	0.00000000E+00	0.11047560E-04	0.10584410E-04

POINT	ITN	T	H	N	O	AR
		C				
1	5	3000.000	-11.376	-14.517	-17.824	-27.214
		-24.401				
2	6	2000.000	-10.689	-13.763	-21.840	-26.262
		-21.257				
3	5	3000.000	-12.569	-15.737	-18.424	-29.649
		-26.155				
4	7	2000.000	-11.843	-14.915	-21.838	-28.566
		-23.564				
5	6	3000.000	-14.102	-17.003	-19.691	-32.180
		-27.343				
6	8	2000.000	-13.001	-16.068	-21.831	-30.871
		-25.879				

THERMODYNAMIC EQUILIBRIUM PROPERTIES AT ASSIGNED

TEMPERATURE AND PRESSURE

CASE = Example-1

	REACTANT	MOLES	ENERGY	TEMP
			CAL/MOL	K
FUEL	H2	1.0000000	0.000	0.000
OXIDANT	Air	1.0000000	0.000	0.000

O/F= 22.85306 %FUEL= 4.192334 R,EQ.RATIO= 1.500000 PHI,EQ.RATIO= 1.500764

THERMODYNAMIC PROPERTIES

P, ATM	1.0000	1.0000	0.10000	0.10000	0.01000	0.01000
T, K	3000.00	2000.00	3000.00	2000.00	3000.00	2000.00
RHO, G/CC	8.1298-5	1.2975-4	7.1204-6	1.2964-5	5.6650-7	1.2930-6
H, CAL/G	712.66	-120.74	1545.93	-116.35	3217.90	-102.27
U, CAL/G	414.78	-307.39	1205.82	-303.16	2790.41	-289.56
G, CAL/G	-8817.98	-5830.59	-9543.81	-6260.51	-10423.3	-6691.09
S, CAL/(G) (K)	3.1769	2.8549	3.6966	3.0721	4.5471	3.2944
M, (1/n)	20.013	21.294	17.528	21.276	13.946	21.220
(dLV/dLP) t	-1.03292	-1.00019	-1.08636	-1.00060	-1.08730	-1.00194
(dLV/dLT) p	1.6619	1.0054	2.6809	1.0172	2.6458	1.0556
Cp, CAL/(G) (K)	1.8179	0.4667	4.2215	0.4987	4.9387	0.6036
GAMMAS	1.1337	1.2531	1.1194	1.2394	1.1295	1.2062
SON VEL,M/SEC	1188.7	989.2	1262.1	984.2	1421.4	972.2

MOLE FRACTIONS

*Ar	0.00620	0.00660	0.00543	0.00659	0.00432	0.00658
*CO	0.00018	0.00016	0.00017	0.00016	0.00014	0.00016
*CO2	0.00004	0.00007	0.00002	0.00007	0.00000	0.00007
*H	0.06014	0.00062	0.18240	0.00196	0.39382	0.00616
*H2	0.14653	0.14737	0.13477	0.14674	0.06283	0.14483
H2O	0.22436	0.29510	0.11320	0.29456	0.01486	0.29279
*N	0.00001	0.00000	0.00003	0.00000	0.00008	0.00000
*NO	0.00573	0.00001	0.00928	0.00003	0.00737	0.00008
*N2	0.51403	0.54996	0.44806	0.54950	0.35646	0.54803
*O	0.00765	0.00000	0.04197	0.00000	0.11820	0.00004
*OH	0.03049	0.00012	0.05073	0.00039	0.03085	0.00124
*O2	0.00463	0.00000	0.01394	0.00000	0.01106	0.00003

* THERMODYNAMIC PROPERTIES FITTED TO 20000.K

PRODUCTS WHICH WERE CONSIDERED BUT WHOSE MOLE FRACTIONS
 WERE LESS THAN 5.000000E-06 FOR ALL ASSIGNED CONDITIONS

*C	HNO	HNO2	HNO3	HO2
*NH	N2O3	O3		

```

! EXAMPLE 2:
! (a) Assigned-temperature-and-volume (or density) problem (tv).
! (b) Reactants are the same as in example 1.
! (c) One temperature was taken from example 1 (t(k)=3000).
! (d) One mixture was taken from example 1 (phi,eq.ratio=1).
! Note: For stoichiometric mixtures, phi = r = 1.
! (e) Densities (rho) were obtained from the results of example 1.
! Composition and properties in examples 1 and 2 should match for
! these input values.
! (f) 'only' dataset is used to restrict possible products.
! (g) Transport properties are to be calculated (transport).

```

```

react fuel=H2 wt%=100
      oxid Air wt%=100
prob case=Example-2 phi,eq.ratio=1, tv t(k)=3000
      rho,g/cc=9.1864d-05,8.0877d-06,6.6054d-07
only Ar C CO CO2 H H2 H2O HNO HO2 HNO2 HNO3 N NH NO N2 N2O3 O O2 OH O3
outp transport calories
end

```

```

OPTIONS: TP=T HP=F SP=F TV=T UV=F SV=F DETN=F SHOCK=F REFL=F INCD=F
RKT=F FROZ=F EQL=F IONS=F SIUNIT=F DEBUGF=F SHKDBG=F DETDBG=F TRNSPT=T

```

T,K = 3000.0000

TRACE= 0.00E+00 S/R= 0.000000E+00 H/R= 0.000000E+00 U/R= 0.000000E+00

SPECIFIC VOLUME,M**3/KG = 1.0885657E+01 1.2364455E+02 1.5139129E+03

REACTANT	WT.FRAC	(ENERGY/R),K	TEMP,K	DENSITY
EXPLODED FORMULA				
F: H2	1.000000	0.000000E+00	0.00	0.0000
H	2.00000			
O: Air	1.000000	0.000000E+00	0.00	0.0000
N	1.56170	O 0.41959	AR 0.00937	C 0.00032

SPECIES BEING CONSIDERED IN THIS SYSTEM
(CONDENSED PHASE MAY HAVE NAME LISTED SEVERAL TIMES)

1 6/88 *Ar	111/88 *C	tpis79 *CO
1 7/88 *CO2	1 6/94 *H	112/89 HNO
tpis89 HNO2	1 4/90 HNO3	1 5/89 HO2
tpis78 *H2	1 8/89 H2O	1 6/88 *N
111/89 *NH	tpis89 *NO	tpis78 *N2
1 4/90 N2O3	1 1/90 *O	tpis78 *OH
tpis89 *O2	1 5/90 O3	

SPECIES WITH TRANSPORT PROPERTIES

PURE SPECIES			
Ar	C	CO	CO2
H	H2		
H2O	N	NO	N2
O	OH		
O2			

BINARY INTERACTIONS

C	O
CO	CO2
CO	N2
CO	O2
CO2	H2
CO2	H2O
CO2	N2
CO2	O2
H	H2
H	N
H	N2
H	O
H2	H2O
H2	N2
H2	O2
H2O	N2
H2O	O2
N	NO
N	N2
N	O
N	O2
NO	O
N2	O
N2	O2
O	O2

O/F = 34.297046

INTERNAL ENERGY (KG-MOL) (K) /KG	EFFECTIVE FUEL u(2) /R 0.00000000E+00	EFFECTIVE OXIDANT u(1) /R 0.00000000E+00	MIXTURE u0/R 0.00000000E+00
KG-FORM.WT./KG	bi(2)	bi(1)	b0i
*H	0.99212255E+00	0.00000000E+00	0.28107807E-01
*N	0.00000000E+00	0.53915548E-01	0.52388068E-01
*O	0.00000000E+00	0.14485769E-01	0.14075373E-01
*Ar	0.00000000E+00	0.32348639E-03	0.31432170E-03
*C	0.00000000E+00	0.11047560E-04	0.10734572E-04

POINT	ITN	T	H	N	O	AR
		C				
1	13	3000.000	-11.767	-14.452	-17.112	-27.077
		-25.140				
2	5	3000.000	-12.811	-15.668	-18.090	-29.507
		-26.387				
3	5	3000.000	-14.310	-16.920	-19.495	-32.012
		-27.378				

THERMODYNAMIC EQUILIBRIUM PROPERTIES AT ASSIGNED

TEMPERATURE AND VOLUME

CASE = Example-2

	REACTANT	WT FRACTION (SEE NOTE)	ENERGY CAL/MOL	TEMP K
FUEL	H2	1.0000000	0.000	0.000
OXIDANT	Air	1.0000000	0.000	0.000

O/F= 34.29705 %FUEL= 2.833098 R,EQ.RATIO= 1.000000 PHI,EQ.RATIO= 1.000000

THERMODYNAMIC PROPERTIES

P, ATM	1.0000	0.10000	0.01000
T, K	3000.00	3000.00	3000.00
RHO, G/CC	9.1864-5	8.0877-6	6.6054-7
H, CAL/G	658.92	1367.61	2655.91
U, CAL/G	395.30	1068.18	2289.29
G, CAL/G	-7973.51	-8615.20	-9379.92
S, CAL/(G) (K)	2.8775	3.3276	4.0119

M, (1/n)	22.615	19.910	16.261
(dLV/dLP)t	-1.03437	-1.07935	-1.07486
(dLV/dLT)p	1.6948	2.5468	2.4145
Cp, CAL/(G) (K)	1.6795	3.4666	3.7240
GAMMAS	1.1311	1.1203	1.1318
SON VEL,M/SEC	1117.0	1184.7	1317.6

TRANSPORT PROPERTIES (GASES ONLY)

CONDUCTIVITY IN UNITS OF MILLICALORIES/(CM) (K) (SEC)

VISC,MILLIPOISE 0.93569 0.94006 0.94815

WITH EQUILIBRIUM REACTIONS

Cp, CAL/(G) (K)	1.6795	3.4666	3.7240
CONDUCTIVITY	4.4242	9.6933	8.8440
PRANDTL NUMBER	0.3552	0.3362	0.3992

WITH FROZEN REACTIONS

Cp, CAL/(G) (K)	0.4250	0.4283	0.4369
CONDUCTIVITY	0.6289	0.7269	0.8650
PRANDTL NUMBER	0.6324	0.5539	0.4789

MOLE FRACTIONS

*Ar	0.00711	0.00626	0.00511
*CO	0.00017	0.00018	0.00017
*CO2	0.00007	0.00003	0.00001
*H	0.04069	0.14315	0.31984
HO2	0.00001	0.00001	0.00000
*H2	0.06708	0.08301	0.04144
H2O	0.20936	0.09741	0.01193
*N	0.00001	0.00003	0.00009
*NO	0.01247	0.01389	0.00974
*N2	0.58613	0.51456	0.42102
*O	0.01560	0.05864	0.14381
*OH	0.04205	0.05562	0.03048
*O2	0.01925	0.02721	0.01637

* THERMODYNAMIC PROPERTIES FITTED TO 20000.K

PRODUCTS WHICH WERE CONSIDERED BUT WHOSE MOLE FRACTIONS
WERE LESS THAN 5.000000E-06 FOR ALL ASSIGNED CONDITIONS

*C	HNO	HNO2	HNO3	*NH
N2O3	O3			

NOTE. WEIGHT FRACTION OF FUEL IN TOTAL FUELS AND OF OXIDANT IN TOTAL OXIDANTS

```

! EXAMPLE 3:
! (a) Combustion or assigned-enthalpy-and-pressure problem (hp).
! (b) Fuels are 'C7H8(L)' and 'C8H18(L),n-octa' at 298.15 K. The oxidant is
! air at 700 K.
! (c) Oxidant-to-fuel weight ratio is 17 (o/f =17). Weight fractions are
! fractions of fuel relative to total fuel and fractions of oxidant
! relative to total oxidant.
! (d) Mixture enthalpy is calculated from reactant values given in
! thermo.lib. This is because data for these species are given in
! thermo.lib and the species names match exactly.
! (e) Many species are omitted from the product data base ('omit' dataset).
! Note: these species names must match those used in thermo.lib.
! (f) Assigned pressures are 100, 10, and 1 bar (p(bar)=100,10,1).
! (g) Mixture properties are to be printed in SI units (siunits).
! (h) Mole fractions > 1.e-15 are to be in e-format (trace=1.e-15).
!

```

```

react
oxid Air wtfrac= 1 t(k)=700.0
fuel C7H8(L) wtfrac= .4 t(k)= 298.15
fuel C8H18(L),n-octa wtfrac= .6 t(k)= 298.15
prob case=Example-3 hp p(bar)=100,10,1, o/f = 17
output siunits trace=1.e-15

```

```

omit CCN          CNC          C2N2          C2O
C3H4,allene      C3H4,propyne   C3H4,cyclo-   C3
C3H5,allyl       C3H6,propylene C3H6,cyclo-   C3H3,propargyl
C3H6O            C3H7,n-propyl  C3H7,i-propyl Jet-A(g)
C3O2             C4              C4H2           C3H8O,2propanol
C4H4,1,3-cyclo- C4H6,butadiene C4H6,2-butyne  C3H8O,1propanol
C4H8,tr2-butene C4H8,isobutene C4H8,cyclo-   C4H6,cyclo-
(CH3COOH)2       C4H9,n-butyl   C4H9,i-butyl   C4H8,1-butene
C4H9,s-butyl     C4H9,t-butyl   C4H10,isobutane C4H8,cis2-buten
C4H10,n-butane   C4N2           C5             C3H8
C5H6,1,3cyclo-  C5H8,cyclo-    C5H10,1-pentene C10H21,n-decyl
C5H10,cyclo-     C5H11,pentyl   C5H11,t-pentyl C12H10,biphenyl
C5H12,n-pentane  C5H12,i-pentane CH3C(CH3)2CH3  C12H9,o-bipheny
C6H6             C6H5OH,phenol  C6H10,cyclo-   C6H2
C6H12,1-hexene  C6H12,cyclo-   C6H13,n-hexyl  C6H5,phenyl
C7H7,benzyl      C7H8           C7H8O,cresol-mx C6H5O,phenoxy
C7H14,1-heptene C7H15,n-heptyl C7H16,n-heptane C10H8,azulene
C8H8,styrene     C8H10,ethylbenz C8H16,1-octene  C10H8,napthlene
C8H17,n-octyl    C8H18,isooctane C8H18,n-octane  C9H19,n-nonyl
Jet-A(L)         C6H6(L)        H2O(s)          H2O(L)
end End all input for example 3

```

```

OPTIONS: TP=F HP=T SP=F TV=F UV=F SV=F DETN=F SHOCK=F REFL=F INCD=F
RKT=F FROZ=F EQL=F IONS=F SIUNIT=T DEBUGF=F SHKDBG=F DETDBG=F TRNSPT=F

```

```

TRACE= 1.00E-15 S/R= 0.000000E+00 H/R= 0.000000E+00 U/R= 0.000000E+00

```

```

P,BAR = 100.000000 10.000000 1.000000

```

REACTANT EXPLODED FORMULA	WT.FRAC	(ENERGY/R),K	TEMP,K	DENSITY
O: Air	1.000000	0.143092E+04	700.00	0.0000
N 2.56170	O 0.41959	AR 0.00937	C 0.00032	
F: C7H8 (L)	0.400000	0.146491E+04	298.15	0.0000
C 7.00000	H 8.00000			
F: C8H18 (L),n-octa	0.600000	-0.300992E+05	298.15	0.0000
C 8.00000	H 18.00000			

SPECIES BEING CONSIDERED IN THIS SYSTEM
(CONDENSED PHASE MAY HAVE NAME LISTED SEVERAL TIMES)

1 6/88 *Ar	111/88 *C	tpis79 *CH
111/89 CH2	111/89 CH3	112/92 CH2OH
110/92 CH3O	1 8/88 CH4	1 8/88 CH3OH
tpis91 *CN	112/89 CNN	tpis79 *CO
1 7/88 *CO2	tpis91 COOH	tpis91 *C2
1 1/91 C2H	1 6/89 CHCO,ketyl	112/89 C2H2,vinylidene
1 1/91 C2H2,acetylene	1 5/90 CH2CO,ketene	1 2/92 C2H3,vinyl
112/92 CH3CN	1 6/96 CH3CO,acetyl	1 1/91 C2H4
1 8/88 C2H4O,ethylen-o	1 8/88 CH3CHO,ethanal	1 8/88 CH3COOH
112/92 C2H5	1 8/88 C2H6	1 8/88 CH3N2CH3
1 8/88 C2H5OH	112/92 CH3OCH3	x10/93 C4H6,1-butyne
x 4/85 C6H14,n-hexane	x10/85 C7H16,2-methylh	1 8/93 C10H8,naphthale
1 6/94 *H	1 7/88 HCN	112/89 HCO
tpis89 HCCN	111/92 HNC	1 2/96 HNCO
112/89 HNO	tpis89 HNO2	1 4/90 HNO3
1 5/89 HO2	tpis78 *H2	1 8/88 HCHO,formaldehy
1 8/88 HCOOH	1 8/89 H2O	1 2/93 H2O2
1 8/88 (HCOOH)2	1 6/88 *N	1 2/96 NCO
111/89 *NH	112/89 NH2	tpis89 NH3
tpis89 NH2OH	tpis89 *NO	1 7/88 NO2
j12/64 NO3	tpis78 *N2	112/89 NCN
1 5/90 N2H2	tpis89 NH2NO2	1 5/90 N2H4
1 7/88 N2O	1 4/90 N2O3	tpis89 N2O4
1 4/90 N2O5	tpis89 N3	1 7/88 N3H
1 1/90 *O	tpis78 *OH	tpis89 *O2
1 5/90 O3	x 4/83 C(gr)	x 4/83 C(gr)
x 4/83 C(gr)		

O/F = 17.000000

ENTHALPY (KG-MOL) (K)/KG	EFFECTIVE FUEL h(2)/R	EFFECTIVE OXIDANT h(1)/R	MIXTURE h0/R
	-0.15173707E+03	0.49400444E+02	0.38226138E+02
KG-FORM.WT./KG	bi(2)	bi(1)	b0i
*N	0.00000000E+00	0.53915548E-01	0.50920240E-01
*O	0.00000000E+00	0.14485769E-01	0.13681004E-01
*Ar	0.00000000E+00	0.32348639E-03	0.30551493E-03
*C	0.72408514E-01	0.11047560E-04	0.40331290E-02
*H	0.12927489E+00	0.00000000E+00	0.71819385E-02

POINT	ITN	T	N	O	AR	C
		H				
1	18	2419.334	-11.651	-14.247	-21.786	-21.401
		-11.891				
2	5	2391.604	-12.783	-15.355	-24.066	-21.672
		-12.538				
3	5	2340.157	-13.898	-16.426	-26.325	-22.191
		-13.247				

THERMODYNAMIC EQUILIBRIUM COMBUSTION PROPERTIES AT ASSIGNED

PRESSURES

CASE = Example-3

	REACTANT	WT FRACTION (SEE NOTE)	ENERGY KJ/KG-MOL	TEMP K
OXIDANT	Air	1.000000	11897.374	700.000
FUEL	C7H8 (L)	0.400000	12180.000	298.150
FUEL	C8H18 (L), n-octa	0.600000	-250259.981	298.150

O/F= 17.00000 %FUEL= 5.555556 R, EQ. RATIO= 0.852074 PHI, EQ. RATIO= 0.851848

THERMODYNAMIC PROPERTIES

P, BAR	100.00	10.000	1.0000
T, K	2419.33	2391.60	2340.16
RHO, KG/CU M	1.4428 1	1.4565 0	1.4827-1
H, KJ/KG	317.83	317.83	317.83
U, KJ/KG	-375.27	-368.76	-356.61
G, KJ/KG	-19443.2	-20795.8	-21891.3
S, KJ/(KG) (K)	8.1680	8.8282	9.4904
M, (1/n)	29.023	28.962	28.849
(dLV/dLP)t	-1.00067	-1.00157	-1.00322
(dLV/dLT)p	1.0186	1.0442	1.0914
Cp, KJ/(KG) (K)	1.6068	1.8127	2.2013
GAMMAS	1.2260	1.2064	1.1803
SON VEL, M/SEC	921.8	910.1	892.2

MOLE FRACTIONS

*Ar	8.8668-3	8.8483-3	8.8139-3
*CN	5.454-14	9.975-14	1.106-13
*CO	1.6811-3	4.3275-3	9.2288-3
*CO2	1.1537-1	1.1248-1	1.0712-1
COOH	5.1792-8	2.3423-8	8.6875-9
*H	2.7692-5	1.2480-4	4.5990-4
HCN	9.662-12	1.081-11	7.934-12
HCO	7.579-10	9.191-10	7.862-10
HNC	1.024-12	1.107-12	7.601-13
HNCO	1.229 -9	5.144-10	1.646-10
HNO	4.2385-7	2.0929-7	9.1839-8
HNO2	1.8549-6	3.2796-7	5.7687-8
HNO3	1.133 -9	6.656-11	4.067-12
HO2	7.8127-6	4.1701-6	2.1216-6
*H2	2.5156-4	6.6471-4	1.4948-3
HCHO, formaldehy	1.723-11	1.172-11	5.625-12
HCOOH	6.485 -9	1.651 -9	3.455-10
H2O	1.0288-1	1.0154-1	9.9280-2
H2O2	1.0129-6	3.0297-7	8.6257-8
*N	1.1572-8	2.7706-8	5.1386-8
NCO	8.645-11	6.074-11	3.090-11
*NH	2.9542-9	3.9044-9	3.9370-9
NH2	1.721 -9	1.291 -9	7.472-10
NH3	3.909 -9	1.731 -9	6.186-10
NH2OH	1.027-11	1.461-12	1.702-13
*NO	6.7922-3	6.5768-3	6.1768-3
NO2	2.3525-5	7.5946-6	2.4942-6
NO3	1.932-10	1.962-11	2.015-12
*N2	7.3550-1	7.3408-1	7.3142-1
N2H2	5.207-13	1.210-13	2.129-14
NH2NO2	2.449-15	6.786-17	1.669-18
N2O	3.6532-6	1.1174-6	3.3132-7
N2O3	2.448-11	7.760-13	2.459-14
N2O4	3.110-15	3.306-17	3.704-19
N3	1.241-12	3.029-13	5.825-14
N3H	3.876-13	5.282-14	5.650-15
*O	1.5576-4	4.3417-4	1.0769-3
*OH	2.1257-3	3.4565-3	5.1814-3
*O2	2.6302-2	2.7452-2	2.9742-2
O3	1.2251-8	3.7798-9	1.1377-9

* THERMODYNAMIC PROPERTIES FITTED TO 20000.K

PRODUCTS WHICH WERE CONSIDERED BUT WHOSE MOLE FRACTIONS
WERE LESS THAN 1.000000E-15 FOR ALL ASSIGNED CONDITIONS

*C	*CH	CH2	CH3	CH2OH
CH3O	CH4	CH3OH	CNN	*C2
C2H	CHCO, ketyl	C2H2, vinylidene	C2H2, acetylene	CH2CO, ketene
C2H3, vinyl	CH3CN	CH3CO, acetyl	C2H4	C2H4O, ethylen-o
CH3CHO, ethanal	CH3COOH	C2H5	C2H6	CH3N2CH3
C2H5OH	CH3OCH3	C4H6, 1-butyne	C6H14, n-hexane	C7H16, 2-methylh
C10H8, naphthale	HCCN	(HCOOH)2	NCN	N2H4
N2O5	C(gr)			

NOTE. WEIGHT FRACTION OF FUEL IN TOTAL FUELS AND OF OXIDANT IN TOTAL OXIDANTS

```

! EXAMPLE 4:
! (a) Assigned-internal-energy-and-density problem (uv).
! (b) Fuel, oxidant, and oxidant-to-fuel weight ratio are the same as in
! example 3.
! (c) Internal energy u was taken from col. 1 of the output of example 3.
! However, input requires u/R, i.e.,  $u = -375.27$  kJ/kg and
!  $u/R = -375.27/8.31451 = -45.1343$  (kg-mol)(K)/kg ( $u/r = -45.1343$ ).
! (d) Units for density input are limited to g/cc and kg/m**3. From
! example 3 point 1,  $\rho = 14.428$  kg/m**3 ( $\rho, \text{kg/m**3} = 14.428$ ).
! (e) Mixture properties are to be printed in SI units (default unit).
! (f) Mole fractions  $> 1.e-15$  are to be in e-format (trace=1.e-15).
! (g) Note that since all parameters for this example are the same as
! those used for col. 1 of example 3, assigning u and rho from
! this column should yield the same pressure and temperature assigned
! for that point in example 3.

```

```

prob case=Example-4, o/f=17 uv u/r=-45.1343, rho,kg/m**3=14.428

```

```

output trace=1.e-15

```

```

reac oxid Air wtfrac= 1 t(k)=700.0
fuel C7H8(L) wtfrac= .4 t(k)= 298.15
fuel C8H18(L),n-octa wtfrac= .6 t(k)= 298.15

```

```

omit CCN CNC C2N2 C2O C3H4,allene C3H4,propyne C3H4,cyclo- C3
C3H5,allyl C3H6,propylene C3H6,cyclo- C3H3,propargyl
C3H6O C3H7,n-propyl C3H7,i-propyl Jet-A(g)
C3O2 C4 C4H2 C3H8O,2propanol
C4H4,1,3-cyclo- C4H6,butadiene C4H6,2-butyne C3H8O,1propanol
C4H8,tr2-butene C4H8,isobutene C4H8,cyclo- C4H6,cyclo-
(CH3COOH)2 C4H9,n-butyl C4H9,i-butyl C4H8,1-butene
C4H9,s-butyl C4H9,t-butyl C4H10,isobutane C4H8,cis2-buten
C4H10,n-butane C4N2 C5 C3H8
C5H6,1,3cyclo- C5H8,cyclo- C5H10,1-pentene C10H21,n-decyl
C5H10,cyclo- C5H11,pentyl C5H11,t-pentyl C12H10,biphenyl
C5H12,n-pentane C5H12,i-pentane CH3C(CH3)2CH3 C12H9,o-bipheny
C6H6 C6H5OH,phenol C6H10,cyclo- C6H2
C6H12,1-hexene C6H12,cyclo- C6H13,n-hexyl C6H5,phenyl
C7H7,benzyl C7H8 C7H8O,cresol-mx C6H5O,phenoxy
C7H14,1-heptene C7H15,n-heptyl C7H16,n-heptane C10H8,azulene
C8H8,styrene C8H10,ethylbenz C8H16,1-octene C10H8,napthlene
C8H17,n-octyl C8H18,isooctane C8H18,n-octane C9H19,n-nonyl
C7H8(L) C8H18(L),n-octa Jet-A(L) C6H6(L) H2O(s) H2O(L)

```

```

end

```

```

OPTIONS: TP=F HP=T SP=F TV=F UV=T SV=F DETN=F SHOCK=F REFL=F INCD=F
RKT=F FROZ=F EQL=F IONS=F SIUNIT=T DEBUGF=F SHKDBG=F DETDBG=F TRNSPT=F

```

```

TRACE= 1.00E-15 S/R= 0.000000E+00 H/R= 0.000000E+00 U/R=-4.513430E+01

```

```

SPECIFIC VOLUME,M**3/KG = 6.9309676E-02

```

REACTANT	WT.FRAC	(ENERGY/R),K	TEMP,K	DENSITY
EXPLODED FORMULA				
O: Air	1.000000	0.730917E+03	700.00	0.0000
N 1.56170	0.41959	AR 0.00937	C 0.00032	
F: C7H8 (L)	0.400000	0.146491E+04	298.15	0.0000
C 7.00000	H 8.00000			
F: C8H18 (L),n-octa	0.600000	-0.300992E+05	298.15	0.0000
C 8.00000	H 18.00000			

SPECIES BEING CONSIDERED IN THIS SYSTEM
(CONDENSED PHASE MAY HAVE NAME LISTED SEVERAL TIMES)

1 6/88 *Ar	111/88 *C	tpis79 *CH
111/89 CH2	111/89 CH3	112/92 CH2OH
110/92 CH3O	1 8/88 CH4	1 8/88 CH3OH
tpis91 *CN	112/89 CNN	tpis79 *CO
1 7/88 *CO2	tpis91 COOH	tpis91 *C2
1 1/91 C2H	1 6/89 CHCO,ketyl	112/89 C2H2,vinylidene
1 1/91 C2H2,acetylene	1 5/90 CH2CO,ketene	1 2/92 C2H3,vinyl
112/92 CH3CN	1 6/96 CH3CO,acetyl	1 1/91 C2H4
1 8/88 C2H4O,ethylen-o	1 8/88 CH3CHO,ethanal	1 8/88 CH3COOH
112/92 C2H5	1 8/88 C2H6	1 8/88 CH3N2CH3
1 8/88 C2H5OH	112/92 CH3OCH3	x10/93 C4H6,1-butyne
x 4/85 C6H14,n-hexane	x10/85 C7H16,2-methylh	1 8/93 C10H8,naphthale
1 6/94 *H	1 7/88 HCN	112/89 HCO
tpis89 HCCN	111/92 HNC	1 2/96 HNCO
112/89 HNO	tpis89 HNO2	1 4/90 HNO3
1 5/89 HO2	tpis78 *H2	1 8/88 HCHO,formaldehy
1 8/88 HCOOH	1 8/89 H2O	1 2/93 H2O2
1 8/88 (HCOOH) 2	1 6/88 *N	1 2/96 NCO
111/89 *NH	112/89 NH2	tpis89 NH3
tpis89 NH2OH	tpis89 *NO	1 7/88 NO2
j12/64 NO3	tpis78 *N2	112/89 NCN
1 5/90 N2H2	tpis89 NH2NO2	1 5/90 N2H4
1 7/88 N2O	1 4/90 N2O3	tpis89 N2O4
1 4/90 N2O5	tpis89 N3	1 7/88 N3H
1 1/90 *O	tpis78 *OH	tpis89 *O2
1 5/90 O3	x 4/83 C(gr)	x 4/83 C(gr)
x 4/83 C(gr)		

O/F = 17.000000

INTERNAL ENERGY (KG-MOL) (K) /KG	EFFECTIVE FUEL u(2)/R	EFFECTIVE OXIDANT u(1)/R	MIXTURE u0/R
	-0.15173707E+03	0.25233905E+02	-0.45134300E+02
KG-FORM.WT. /KG	bi(2)	bi(1)	b0i
*N	0.00000000E+00	0.53915548E-01	0.50920240E-01
*O	0.00000000E+00	0.14485769E-01	0.13681004E-01
*Ar	0.00000000E+00	0.32348639E-03	0.30551493E-03
*C	0.72408514E-01	0.11047560E-04	0.40331290E-02
*H	0.12927489E+00	0.00000000E+00	0.71819385E-02

POINT	ITN	T	H	N	O	AR	C
1	16	2419.335	-11.891	-11.651	-14.247	-21.786	-21.401

OTHER THERMODYNAMIC EQUILIBRIUM COMBUSTION PROPERTIES AT ASSIGNED

VOLUME

CASE = Example-4,

REACTANT	WT FRACTION (SEE NOTE)	ENERGY KJ/KG-MOL	TEMP K
OXIDANT Air	1.000000	6077.217	700.000
FUEL C7H8 (L)	0.400000	12180.000	298.150
FUEL C8H18 (L), n-octa	0.600000	-250259.981	298.150

O/F= 17.00000 %FUEL= 5.555556 R,EQ.RATIO= 0.852074 PHI,EQ.RATIO= 0.851848

THERMODYNAMIC PROPERTIES

P, BAR 100.00
T, K 2419.34
RHO, KG/CU M 1.4428 1
H, KJ/KG 317.83
U, KJ/KG -375.27
G, KJ/KG -19443.2
S, KJ/(KG) (K) 8.1680
M, (1/n) 29.023
(dLV/dLP)t -1.00067
(dLV/dLT)p 1.0186
Cp, KJ/(KG) (K) 1.6068
GAMMAS 1.2260
SON VEL, M/SEC 921.8

MOLE FRACTIONS

*Ar 8.8668-3
*CN 5.454-14
*CO 1.6811-3
*CO2 1.1537-1
COOH 5.1793-8
*H 2.7692-5
HCN 9.662-12
HCO 7.579-10
HNC 1.024-12
HNCO 1.2290-9

HNO	4.2385-7
HNO2	1.8549-6
HNO3	1.1332-9
HO2	7.8128-6
*H2	2.5156-4
HCHO,formaldehy	1.723-11
HCOOH	6.4854-9
H2O	1.0288-1
H2O2	1.0130-6
*N	1.1572-8
NCO	8.645-11
*NH	2.9542-9
NH2	1.7208-9
NH3	3.9091-9
NH2OH	1.027-11
*NO	6.7922-3
NO2	2.3525-5
NO3	1.932-10
*N2	7.3550-1
N2H2	5.207-13
NH2NO2	2.450-15
N2O	3.6532-6
N2O3	2.448-11
N2O4	3.110-15
N3	1.241-12
N3H	3.876-13
*O	1.5576-4
*OH	2.1257-3
*O2	2.6302-2
O3	1.2251-8

* THERMODYNAMIC PROPERTIES FITTED TO 20000.K

PRODUCTS WHICH WERE CONSIDERED BUT WHOSE MOLE FRACTIONS
WERE LESS THAN 1.000000E-15 FOR ALL ASSIGNED CONDITIONS

*C	*CH	CH2	CH3	CH2OH
CH3O	CH4	CH3OH	CNN	*C2
C2H	CHCO,ketyl	C2H2,vinylidene	C2H2,acetylene	CH2CO,ketene
C2H3,vinyl	CH3CN	CH3CO,acetyl	C2H4	C2H4O,ethylen-o
CH3CHO,ethanal	CH3COOH	C2H5	C2H6	CH3N2CH3
C2H5OH	CH3OCH3	C4H6,1-butyne	C6H14,n-hexane	C7H16,2-methylh
C10H8,naphthale	HCCN	(HCOOH) 2	NCN	N2H4
N2O5	C(gr)			

NOTE. WEIGHT FRACTION OF FUEL IN TOTAL FUELS AND OF OXIDANT IN TOTAL OXIDANTS

```

! EXAMPLE 5:
! (a) Combustion problem (hp) for solid propellant with 5 ingredients.
! (b) The assigned enthalpies and "exploded" formulas for four of the
! components are to be taken from thermo.lib. However, data for
! 'CHOS-Binder' are not available in thermo.lib and thus the "exploded"
! formula and enthalpy are given in the 'reac' dataset.
! (c) The reactants are given in percent by weight (wt%=...). The
! propellant components are not designated as fuel and oxidant - they
! are labelled with the 'name' alternative. Weight fractions are
! relative to the total reactant.
! (d) Five pressures are given in units of psia (p,psia=500,250,
! 125,50,5,).
! (e) As with examples 3 and 4, many species in thermo.lib are omitted
! as possible products by means of an 'omit' dataset.
! (f) Energy units in the final tables are in calories (calories).

```

```
reac
```

```

name NH4CLO4(I) wt%= 72.06 t(k)=298.15
name CHOS-Binder C 1 H 1.86955 O .031256 S .008415 wt%=18.58
h,cal=-2999.082 t(k)=298.15

name AL(cr) wt%= 9. t(k)=298.15
name MgO(s) wt%= .2 t(k)=298.15
name H2O(L) wt%=.16 t(k)=298.15

```

```
prob case=5, hp p,psia=500,250,125,50,5,
```

```
outp calories
```

```

omit COOH C2 C2H CHCO,ketyl C2H2,vinylidene CH2CO,ketene C2H3,vinyl
CH3CO,acetyl C2H4O,ethylen-o CH3CHO,ethanal CH3COOH (HCOOH)2
C2H5 C2H6 CH3N2CH3 CH3OCH3
C2H5OH CCN CNC C2N2
C2O C3 C3H3,propargyl C3H4,allene
C3H4,propyne C3H4,cyclo- C3H5,allyl C3H6,propylene
C3H6,cyclo- C3H6O C3H7,n-propyl C3H7,i-propyl
C3H8 C3H8O,1propanol C3H8O,2propanol C3O2
C4 C4H2 C4H4,1,3-cyclo- C4H6,butadiene
C4H6,2-butyne C4H6,cyclo- C4H8,1-butene C4H8,cis2-buten
C4H8,tr2-butene C4H8,isobutene C4H8,cyclo- (CH3COOH)2
C4H9,n-butyl C4H9,i-butyl C4H9,s-butyl C4H9,t-butyl
C4H10,isobutane C4H10,n-butane C4N2 C5
C5H6,1,3cyclo- C5H8,cyclo- C5H10,1-pentene C5H10,cyclo-
C5H11,pentyl C5H11,t-pentyl C5H12,n-pentane C5H12,i-pentane
CH3C(CH3)2CH3 C6H2 C6H5,phenyl C6H5O,phenoxy
C6H6 C6H5OH,phenol C6H10,cyclo- C6H12,1-hexene
C6H12,cyclo- C6H13,n-hexyl C7H7,benzyl C7H8
C7H8O,cresol-mx C7H14,1-heptene C7H15,n-heptyl C7H16,n-heptane
C8H8,styrene C8H10,ethylbenz C8H16,1-octene C8H17,n-octyl
C8H18,isooctane C8H18,n-octane C9H19,n-nonyl C10H8,naphthale
C10H21,n-decyl C12H9,o-bipheny C12H10,biphenyl Jet-A(g)
HNCO HNO HNO2 HNO3 HCCN HCHO,formaldehy HCOOH
NH NH2 NH2OH NCN N2H2 NH2NO2 N2H4 H2O2
(HCOOH)2 C6H6(L) C7H8(L) C8H18(L),n-octa Jet-A(L) H2O(s) H2O(L)
end

```

OPTIONS: TP=F HP=T SP=F TV=F UV=F SV=F DETN=F SHOCK=F REFL=F INCD=F
 RKT=F FROZ=F EQL=F IONS=F SIUNIT=F DEBUGF=F SHKDBG=F DETDBG=F TRNSPT=F

TRACE= 0.00E+00 S/R= 0.000000E+00 H/R= 0.000000E+00 U/R= 0.000000E+00

P, BAR = 34.473652 17.236826 8.618413 3.447365 0.344737

REACTANT	WT.FRAC	(ENERGY/R),K	TEMP,K	DENSITY
EXPLODED FORMULA				
N: NH4CLO4(I)	0.720600	-0.355724E+05	298.15	0.0000
N 1.00000	H 4.00000	CL 1.00000	O 4.00000	
N: CHOS-Binder	0.185800	-0.150919E+04	298.15	0.0000
C 1.00000	H 1.86955	O 0.03126	S 0.00841	
N: AL(cr)	0.090000	0.496279E-05	298.15	0.0000
AL 1.00000				
N: MgO(s)	0.002000	-0.723139E+05	298.15	0.0000
MG 1.00000	O 1.00000			
N: H2O(L)	0.001600	-0.343773E+05	298.15	0.0000
H 2.00000	O 1.00000			

SPECIES BEING CONSIDERED IN THIS SYSTEM
 (CONDENSED PHASE MAY HAVE NAME LISTED SEVERAL TIMES)

j 6/83	*AL	J 6/63	ALC	J 9/79	ALCL
J 6/76	ALCL2	J 9/79	ALCL3	J 6/63	ALH
J12/79	ALN	J12/79	ALO	J 9/64	ALOCL
J12/67	ALOH	J12/79	ALO2	J12/68	ALO2H
j12/79	ALS	J 6/79	AL2	J 9/79	AL2CL6
J12/79	AL2O	J12/79	AL2O2	111/88	*C
111/95	CCL	111/95	CCL2	x12/93	CCL3
tpis91	CCL4	tpis79	*CH	111/95	CHCL
x12/93	CHCL2	l 6/95	CHCL3	111/89	CH2
l 2/96	CH2CL	tpis91	CH2CL2	111/89	CH3
tpis91	CH3CL	112/92	CH2OH	110/92	CH3O
l 8/88	CH4	l 8/88	CH3OH	tpis91	*CN
112/89	CNN	tpis79	*CO	tpis91	COCL
tpis91	COCL2	tpis91	COHCL	l 6/95	COS
l 7/88	*CO2	l 7/95	CS	l 6/95	CS2
tpis91	C2CL	tpis91	C2CL2	tpis91	C2CL3
tpis91	C2CL4	tpis91	C2CL6	tpis91	C2HCL
tpis91	C2HCL3	l 1/91	C2H2, acetylene	tpis91	C2H2CL2
tpis91	C2H3CL	112/92	CH3CN	l 1/91	C2H4
x10/93	C4H6, 1-butyne	x 4/85	C6H14, n-hexane	x10/85	C7H16, 2-methylh
J 6/82	CL	l 6/95	CLCN	tpis89	CLO
l 7/93	CLO2	tpis89	CL2	tpis89	CL2O
l 6/94	*H	J 3/64	HALO	l 7/88	HCN
112/89	HCO	tpis89	HCL	111/92	HNC
tpis89	HOCL	l 5/89	HO2	tpis78	*H2
l 8/89	H2O	tpis89	H2S	tpis89	H2SO4
J 9/83	Mg	J 3/66	MgCL	J12/69	MgCL2
J12/66	MgH	J 3/64	MgN	J12/74	MgO
J12/75	MgOH	J12/75	MgO2H2	J 9/77	MgS
J 9/83	Mg2	l 6/88	*N	l 2/96	NCO
tpis89	NH3	tpis89	*NO	l 5/95	NOCL

l 7/88	NO2	l 5/95	NO2CL	j12/64	NO3
tpis78	*N2	l 7/88	N2O	l 4/90	N2O3
tpis89	N2O4	l 4/90	N2O5	tpis89	N3
l 7/88	N3H	l 1/90	*O	tpis78	*OH
tpis89	*O2	l 5/90	O3	J 9/82	S
J 6/78	SCL	J 6/78	SCL2	tpis89	SH
tpis89	SN	tpis89	SO	tpis89	SO2
J 6/71	SO2CL2	tpis89	SO3	tpis89	S2
L 4/93	S2CL2	tpis89	S2O	tpis89	S3
tpis89	S4	tpis89	S5	tpis89	S6
tpis89	S7	tpis89	S8	coda89	AL(cr)
coda89	AL(L)	J 9/79	ALCL3(s)	J 9/79	ALCL3(L)
J 9/79	ALCL3(L)	J12/79	ALN(s)	J12/79	ALN(s)
coda89	AL2O3(a)	coda89	AL2O3(a)	coda89	AL2O3(a)
coda89	AL2O3(L)	x 4/83	C(gr)	x 4/83	C(gr)
x 4/83	C(gr)	J 9/77	H2SO4(L)	srd 93	Mg(cr)
srd 93	Mg(cr)	srd 93	Mg(L)	J12/79	MgAL2O4(s)
J12/79	MgAL2O4(s)	J12/79	MgAL2O4(L)	J12/66	MgCO3(s)
J12/65	MgCL2(s)	J12/65	MgCL2(L)	J12/65	MgCL2(L)
J12/74	MgO(s)	J12/74	MgO(s)	J12/74	MgO(L)
J12/75	MgO2H2(s)	J 9/77	MgS(s)	J 9/77	MgS(s)
L 7/76	MgSO4(s)	L 7/76	MgSO4(s)	L 7/76	MgSO4(L)
BAR 73	NH4CL(a)	BAR 73	NH4CL(b)	tpis89	S(cr1)
tpis89	S(cr2)	tpis89	S(L)	tpis89	S(L)
tpis89	S(L)	tpis89	S(L)	tpis89	S(L)
J 6/78	SCL2(L)	J 6/78	SCL2(L)	J 6/78	S2CL2(L)
J 6/78	S2CL2(L)				

O/F = 0.000000

ENTHALPY	EFFECTIVE FUEL	EFFECTIVE OXIDANT	MIXTURE
(KG-MOL) (K) /KG	h(2) /R	h(1) /R	h0/R
	-0.24393994E+03	0.00000000E+00	-0.24393994E+03
KG-FORM.WT. /KG	bi(2)	bi(1)	b0i
*N	0.61333506E-02	0.00000000E+00	0.61333506E-02
*H	0.48397025E-01	0.00000000E+00	0.48397025E-01
CL	0.61333506E-02	0.00000000E+00	0.61333506E-02
*O	0.25067832E-01	0.00000000E+00	0.25067832E-01
*C	0.12669356E-01	0.00000000E+00	0.12669356E-01
S	0.10661263E-03	0.00000000E+00	0.10661263E-03
*AL	0.33356140E-02	0.00000000E+00	0.33356140E-02
Mg	0.49622374E-04	0.00000000E+00	0.49622374E-04

POINT	ITN	T	C	N	S	H	AL	CL	MG	O
1	15	2223.217	-10.257	-13.211	-16.675	-8.721	-13.362	-22.552	-21.039	-21.610
ADD AL2O3 (a)										
1	7	2800.188	-11.789	-13.618	-17.418	-9.082	-18.816	-20.821	-21.663	-19.613
PHASE CHANGE, REPLACE AL2O3 (a) WITH AL2O3 (L)										
1	2	2724.464	-11.563	-13.567	-17.289	-9.031	-19.670	-20.870	-21.824	-19.869
2	3	2708.020	-12.208	-13.903	-17.473	-9.369	-19.750	-21.234	-21.884	-19.927
3	3	2687.754	-12.840	-14.237	-17.703	-9.704	-19.850	-21.603	-21.967	-19.999
4	3	2654.796	-13.657	-14.675	-18.073	-10.143	-20.018	-22.098	-22.121	-20.119
5	4	2542.768	-15.608	-15.754	-19.236	-11.231	-20.635	-23.383	-22.836	-20.548

THERMODYNAMIC EQUILIBRIUM COMBUSTION PROPERTIES AT ASSIGNED
PRESSURES

CASE = 5

NAME	REACTANT	WT FRACTION (SEE NOTE)	ENERGY CAL/MOL	TEMP K
NAME	NH4CLO4 (I)	0.7206000	-70690.009	298.150
NAME	CHOS-Binder	0.1858000	-2999.082	298.150
NAME	AL(cr)	0.0900000	0.000	298.150
NAME	MgO(s)	0.0020000	-143703.308	298.150
NAME	H2O(L)	0.0016000	-68315.026	298.150

O/F= 0.00000 %FUEL= 0.000000 R, EQ. RATIO= 1.947910 PHI, EQ. RATIO= 0.000000

THERMODYNAMIC PROPERTIES

P, ATM	34.023	17.011	8.5057	3.4023	0.34023
T, K	2724.46	2708.02	2687.75	2654.80	2542.77
RHO, G/CC	3.5209-3	1.7681-3	8.8885-4	3.5874-4	3.7034-5
H, CAL/G	-484.76	-484.76	-484.76	-484.76	-484.76
U, CAL/G	-718.77	-717.76	-716.50	-714.44	-707.24
G, CAL/G	-7370.89	-7490.69	-7598.71	-7721.56	-7925.43
S, CAL/(G) (K)	2.5275	2.5871	2.6468	2.7259	2.9262
M, (1/n)	23.136	23.096	23.048	22.970	22.712
MW, MOL WT	22.282	22.246	22.202	22.130	21.893
(dLV/dLP) t	-1.00263	-1.00342	-1.00438	-1.00590	-1.01098
(dLV/dLT) p	1.0518	1.0686	1.0892	1.1228	1.2412
Cp, CAL/(G) (K)	0.5744	0.6051	0.6435	0.7082	0.9512
GAMMAS	1.1945	1.1890	1.1828	1.1738	1.1504
SON VEL, M/SEC	1081.4	1076.6	1070.9	1062.1	1034.8

MOLE FRACTIONS

ALCL	0.00019	0.00024	0.00030	0.00037	0.00052
ALCL2	0.00014	0.00013	0.00011	0.00010	0.00005
ALCL3	0.00007	0.00005	0.00003	0.00002	0.00000
ALO	0.00000	0.00000	0.00000	0.00000	0.00001
ALOCL	0.00008	0.00010	0.00012	0.00015	0.00023
ALOH	0.00001	0.00002	0.00002	0.00003	0.00004
ALO2H	0.00002	0.00003	0.00003	0.00004	0.00006
*CO	0.26445	0.26396	0.26337	0.26238	0.25895
COS	0.00005	0.00004	0.00003	0.00002	0.00001
*CO2	0.01779	0.01783	0.01788	0.01797	0.01841
CL	0.00168	0.00222	0.00290	0.00401	0.00790
*H	0.00591	0.00785	0.01027	0.01427	0.02829
HCN	0.00001	0.00000	0.00000	0.00000	0.00000
HCO	0.00001	0.00000	0.00000	0.00000	0.00000
HCL	0.13214	0.13144	0.13055	0.12912	0.12434
*H2	0.32150	0.32075	0.31979	0.31813	0.31176
H2O	0.14659	0.14594	0.14516	0.14391	0.13984
H2S	0.00136	0.00113	0.00089	0.00060	0.00018
Mg	0.00002	0.00004	0.00007	0.00013	0.00044
MgCL	0.00003	0.00004	0.00005	0.00006	0.00008
MgCL2	0.00104	0.00101	0.00096	0.00088	0.00054
MgOH	0.00001	0.00001	0.00001	0.00002	0.00002
MgO2H2	0.00001	0.00000	0.00000	0.00000	0.00000
NH3	0.00001	0.00001	0.00000	0.00000	0.00000
*NO	0.00003	0.00003	0.00004	0.00005	0.00009
*N2	0.06831	0.06820	0.06806	0.06784	0.06710
*O	0.00001	0.00001	0.00002	0.00005	0.00016
*OH	0.00070	0.00092	0.00118	0.00157	0.00275
*O2	0.00000	0.00000	0.00000	0.00001	0.00003
S	0.00009	0.00013	0.00019	0.00027	0.00043
SH	0.00062	0.00069	0.00073	0.00071	0.00049
SO	0.00015	0.00023	0.00033	0.00048	0.00082
SO2	0.00006	0.00009	0.00013	0.00019	0.00036
S2	0.00002	0.00003	0.00004	0.00004	0.00002
AL2O3 (L)	0.03691	0.03682	0.03672	0.03655	0.03606

* THERMODYNAMIC PROPERTIES FITTED TO 20000.K

PRODUCTS WHICH WERE CONSIDERED BUT WHOSE MOLE FRACTIONS
WERE LESS THAN 5.000000E-06 FOR ALL ASSIGNED CONDITIONS

*AL	ALC	ALH	ALN	ALO2
ALS	AL2	AL2CL6	AL2O	AL2O2
*C	CCL	CCL2	CCL3	CCL4
*CH	CHCL	CHCL2	CHCL3	CH2
CH2CL	CH2CL2	CH3	CH3CL	CH2OH
CH3O	CH4	CH3OH	*CN	CNN

COCL	COCL2	COHCL	CS	CS2
C2CL	C2CL2	C2CL3	C2CL4	C2CL6
C2HCL	C2HCL3	C2H2, acetylene	C2H2CL2	C2H3CL
CH3CN	C2H4	C4H6, 1-butyne	C6H14, n-hexane	C7H16, 2-methylh
CLCN	CLO	CLO2	CL2	CL2O
HALO	HNC	HOCL	HO2	H2SO4
MgH	MgN	MgO	MgS	Mg2
*N	NCO	NOCL	NO2	NO2CL
NO3	N2O	N2O3	N2O4	N2O5
N3	N3H	O3	SCL	SCL2
SN	SO2CL2	SO3	S2CL2	S2O
S3	S4	S5	S6	S7
S8	AL (cr)	AL (L)	ALCL3 (s)	ALCL3 (L)
ALN (s)	AL2O3 (a)	C (gr)	H2SO4 (L)	Mg (cr)
Mg (L)	MgAL2O4 (s)	MgAL2O4 (L)	MgCO3 (s)	MgCL2 (s)
MgCL2 (L)	MgO (s)	MgO (L)	MgO2H2 (s)	MgS (s)
MgSO4 (s)	MgSO4 (L)	NH4CL (a)	NH4CL (b)	S (cr1)
S (cr2)	S (L)	SCL2 (L)	S2CL2 (L)	

NOTE. WEIGHT FRACTION OF FUEL IN TOTAL FUELS AND OF OXIDANT IN TOTAL OXIDANTS

```

! EXAMPLE 6:
! (a) Chapman-Jouguet detonation problem (detonation)
! (b) The reactants are H2 and O2 gases. The mixture is
! stoichiometric (r,e=1).
! (c) The unburned gases are at 298.15 and 500 K and pressures
! 1 bar and 30 bars (t,k=298.15,500, pbar=1,30)
! (d) Thermal transport properties are called for (transport).
! (e) Energy units in the final tables are in calories (calories).

react oxid O2 wt%=100 t(k)=298.15
      fuel H2 wt%=100. t(k)=298.15

prob detonation case=6 t=298.15,500, r,e=1, pbar=1,20

output calories transport
end

OPTIONS: TP=F HP=F SP=F TV=F UV=F SV=F DETN=T SHOCK=F REFL=F INCD=F
RKT=F FROZ=F EQL=F IONS=F SIUNIT=F DEBUGF=F SHKDBG=F DETDBG=F TRNSPT=T

T,K = 298.1500 500.0000

TRACE= 0.00E+00 S/R= 0.000000E+00 H/R= 0.000000E+00 U/R= 0.000000E+00

P,BAR = 1.000000 20.000000

      REACTANT          WT.FRAC  (ENERGY/R),K  TEMP,K  DENSITY
      EXPLODED FORMULA
O: O2          1.000000  -0.988319E-06  298.15  0.0000
      O 2.00000
F: H2          1.000000  -0.489101E-05  298.15  0.0000
      H 2.00000

      SPECIES BEING CONSIDERED IN THIS SYSTEM
      (CONDENSED PHASE MAY HAVE NAME LISTED SEVERAL TIMES)

1 6/94 *H          1 5/89 HO2          tpis78 *H2
1 8/89 H2O        1 2/93 H2O2          1 1/90 *O
tpis78 *OH        tpis89 *O2          1 5/90 O3
1 8/89 H2O(s)    1 8/89 H2O(L)

```

SPECIES WITH TRANSPORT PROPERTIES

PURE SPECIES

H	H2	H2O	O
OH	O2		

BINARY INTERACTIONS

H	H2
H	O
H2	H2O
H2	O2
H2O	O2
O	O2

O/F = 7.936683

ENTHALPY (KG-MOL) (K) /KG	EFFECTIVE FUEL h(2)/R	EFFECTIVE OXIDANT h(1)/R	MIXTURE h0/R
	-0.24262412E-05	-0.30886113E-07	-0.29892238E-06
KG-FORM.WT./KG	bi(2)	bi(1)	b0i
*O	0.00000000E+00	0.62502344E-01	0.55508435E-01
*H	0.99212255E+00	0.00000000E+00	0.11101687E+00

POINT	ITN	T	O	H
1	8	3609.250	-15.678	-10.324

POINT	ITN	T	O	H
1	3	3637.136	-15.600	-10.241

POINT	ITN	T	O	H
1	3	3680.926	-15.602	-10.237

POINT	ITN	T	O	H
1	2	3679.599	-15.602	-10.237
2	5	4147.454	-14.591	-9.159
2	3	4219.559	-14.489	-9.047
2	3	4292.394	-14.492	-9.042
2	2	4290.262	-14.492	-9.042
3	6	3727.581	-15.710	-10.339
3	3	3669.044	-15.808	-10.446
3	3	3606.911	-15.806	-10.454
3	2	3604.962	-15.806	-10.454
4	5	4336.573	-14.632	-9.177
4	3	4267.642	-14.689	-9.242
4	3	4216.603	-14.687	-9.247
4	2	4216.063	-14.687	-9.247

DETONATION PROPERTIES OF AN IDEAL REACTING GAS

CASE = 6

	REACTANT		WT FRACTION (SEE NOTE)	ENERGY CAL/MOL	TEMP K
OXIDANT	O2		1.0000000	0.000	298.150
FUEL	H2		1.0000000	0.000	298.150

O/F= 7.93668 %FUEL= 11.189834 R, EQ. RATIO= 1.000000 PHI, EQ. RATIO= 1.000000

UNBURNED GAS

P1, ATM	0.9869	19.7385	0.9869	19.7385
T1, K	298.15	298.15	500.00	500.00
H1, CAL/G	0.00	0.00	118.41	118.41
M1, (1/n)	12.010	12.010	12.010	12.010
GAMMA1	1.4016	1.4016	1.3858	1.3858
SON VEL1, M/SEC	537.9	537.9	692.6	692.6

BURNED GAS

P, ATM	18.542	409.40	10.824	240.42
T, K	3679.60	4290.26	3604.96	4216.06
RHO, G/CC	8.9087-4	1.7754-2	5.2196-4	1.0421-2
H, CAL/G	677.36	752.70	758.96	837.29
U, CAL/G	173.32	194.25	256.74	278.61
G, CAL/G	-14642.7	-15416.7	-14599.2	-15431.0
S, CAL/(G) (K)	4.1635	3.7689	4.2603	3.8587
M, (1/n)	14.507	15.267	14.264	14.996
(dLV/dLP)t	-1.08257	-1.06066	-1.08950	-1.06761
(dLV/dLT)p	2.3666	1.8752	2.5062	1.9883
Cp, CAL/(G) (K)	3.9031	2.4578	4.3365	2.7278
GAMMAS	1.1287	1.1436	1.1265	1.1421
SON VEL, M/SEC	1542.8	1634.6	1538.5	1633.9

TRANSPORT PROPERTIES (GASES ONLY)

CONDUCTIVITY IN UNITS OF MILLICALORIES/(CM) (K) (SEC)

VISC, MILLIPOISE	1.1411	1.2744	1.1243	1.2591
------------------	--------	--------	--------	--------

WITH EQUILIBRIUM REACTIONS

Cp, CAL/(G) (K)	3.9031	2.4578	4.3365	2.7278
CONDUCTIVITY	9.1690	5.9829	10.1413	6.6951
PRANDTL NUMBER	0.4857	0.5235	0.4808	0.5130

WITH FROZEN REACTIONS

Cp, CAL/(G) (K)	0.7788	0.7939	0.7769	0.7923
CONDUCTIVITY	1.2925	1.4230	1.2844	1.4190
PRANDTL NUMBER	0.6876	0.7110	0.6800	0.7030

DETONATION PARAMETERS

P/P1	18.788	20.741	10.968	12.180
T/T1	12.341	14.390	7.210	8.432
M/M1	1.2079	1.2712	1.1877	1.2486
RHO/RHO1	1.8388	1.8322	1.8067	1.8037
DET MACH NUMBER	5.2744	5.5684	4.0135	4.2551
DET VEL,M/SEC	2836.9	2995.1	2779.7	2947.1

MOLE FRACTIONS

*H	0.08098	0.04765	0.09195	0.05702
HO2	0.00019	0.00069	0.00015	0.00058
*H2	0.16234	0.14401	0.16705	0.15222
H2O	0.53502	0.61304	0.51045	0.58216
H2O2	0.00002	0.00017	0.00001	0.00012
*O	0.03848	0.02411	0.04330	0.02868
*OH	0.13460	0.13210	0.13646	0.13826
*O2	0.04837	0.03823	0.05063	0.04096

* THERMODYNAMIC PROPERTIES FITTED TO 20000.K

PRODUCTS WHICH WERE CONSIDERED BUT WHOSE MOLE FRACTIONS
WERE LESS THAN 5.000000E-06 FOR ALL ASSIGNED CONDITIONS

O3	H2O(s)	H2O(L)
----	--------	--------

NOTE. WEIGHT FRACTION OF FUEL IN TOTAL FUELS AND OF OXIDANT IN TOTAL OXIDANTS

```

! EXAMPLE 7:
! (a) Shock tube problem (shock).
! (b) Reactants are H2, O2, and Ar gases at 300 K. Note that for shock
! problems reactants must be gaseous species in the thermodynamic
! data base. The program calculates properties of the
! reactants at the temperature given (300 K) using the thermo.lib
! coefficients.
! (c) Reactants are given in moles (moles = ...).
! (d) Initial gas pressures are 10 and 20 mm Hg (p,mmhg=10,20,)
! (e) Seven initial gas velocities are assigned (u1=1000,1100,1200,
! 1250,1300,1350,1400,). Note units of u1 are always m/s.
! (f) Equilibrium calculations are to be performed for incident shock
! conditions (incd eql).
! (g) Frozen calculations are to be performed for incident shock
! conditions (incd froz).
! (h) No 'outp' dataset is given since the default values of the
! parameters have the desired values (e.g. SI units).

```

```

react name= H2 moles= 0.050 t(k) 300.00
      name= O2 moles= 0.050 t(k) 300.00
      name= Ar moles= 0.900 t(k) 300.00

```

```

problem case=7 p,mmhg=10,20, shock u1=1000,1100,1200,1250,1300,1350,1400,
      incd froz eql

```

```
end
```

```

OPTIONS: TP=F HP=F SP=F TV=F UV=F SV=F DETN=F SHOCK=T REFL=F INCD=T
RKT=F FROZ=T EQL=T IONS=F SIUNIT=T DEBUGF=F SHKDBG=F DETDBG=F TRNSPT=F

```

```
TRACE= 0.00E+00 S/R= 0.000000E+00 H/R= 0.000000E+00 U/R= 0.000000E+00
```

```
P,BAR = 0.013332 0.026664
```

REACTANT	MOLES	(ENERGY/R), K	TEMP, K	DENSITY
EXPLODED FORMULA				
N: H2	0.050000	0.641758E+01	300.00	0.0000
H 2.00000				
N: O2	0.050000	0.653777E+01	300.00	0.0000
O 2.00000				
N: Ar	0.900000	0.462500E+01	300.00	0.0000
AR 1.00000				

```

SPECIES BEING CONSIDERED IN THIS SYSTEM
(CONDENSED PHASE MAY HAVE NAME LISTED SEVERAL TIMES)

```

1 6/88 *Ar	1 6/94 *H	1 5/89 HO2
tpis78 *H2	1 8/89 H2O	1 2/93 H2O2
1 1/90 *O	tpis78 *OH	tpis89 *O2
1 5/90 O3	1 8/89 H2O(s)	1 8/89 H2O(L)

*** INPUT FOR SHOCK PROBLEMS ***

INCDEQ = T REFLEQ = F INCDFZ = T REFLFZ = F

U1 = 1.000000E+03 1.100000E+03 1.200000E+03 1.250000E+03 1.300000E+03
1.350000E+03 1.400000E+03

MACH1 = 0.000000E+00 0.000000E+00 0.000000E+00 0.000000E+00 0.000000E+00
0.000000E+00 0.000000E+00

O/F = 0.000000

ENTHALPY (KG-MOL) (K) /KG	EFFECTIVE FUEL h(2) /R	EFFECTIVE OXIDANT h(1) /R	MIXTURE h0/R
	0.12774941E+00	0.00000000E+00	0.12774941E+00
KG-FORM.WT./KG	bi(2)	bi(1)	bi0i
*H	0.26557650E-02	0.00000000E+00	0.26557650E-02
*O	0.26557650E-02	0.00000000E+00	0.26557650E-02
*Ar	0.23901885E-01	0.00000000E+00	0.23901885E-01

SHOCK WAVE PARAMETERS ASSUMING
EQUILIBRIUM COMPOSITION FOR INCIDENT SHOCKED CONDITIONS

CASE = 7

REACTANT	MOLES	ENERGY KJ/KG-MOL	TEMP K
NAME H2	0.0500000	53.359	300.000
NAME O2	0.0500000	54.358	300.000
NAME Ar	0.9000000	38.455	300.000

O/F= 0.00000 %FUEL= 0.000000 R,EQ.RATIO= 0.500000 PHI,EQ.RATIO= 0.000000

INITIAL GAS (1)

MACH NUMBER1	3.0480	3.3528	3.6576	3.8100	3.9624	4.1148	4.2672
U1, M/SEC	1000.00	1100.00	1200.00	1250.00	1300.00	1350.00	1400.00
P, BAR	0.01333	0.02666	0.02666	0.02666	0.02666	0.02666	0.02666
T, K	300.00	300.00	300.00	300.00	300.00	300.00	300.00
RHO, KG/CU M	2.0126-2	4.0252-2	4.0252-2	4.0252-2	4.0252-2	4.0252-2	4.0252-2
H, KJ/KG	1.0622	1.0622	1.0622	1.0622	1.0622	1.0622	1.0622
U, KJ/KG	-65.182	-65.182	-65.182	-65.182	-65.182	-65.182	-65.182
G, KJ/KG	-1556.26	-1510.35	-1510.35	-1510.35	-1510.35	-1510.35	-1510.35
S, KJ/(KG) (K)	5.1911	5.0380	5.0380	5.0380	5.0380	5.0380	5.0380
M, (1/n)	37.654	37.654	37.654	37.654	37.654	37.654	37.654
Cp, KJ/(KG) (K)	0.5742	0.5742	0.5742	0.5742	0.5742	0.5742	0.5742
GAMMAS	1.6249	1.6249	1.6249	1.6249	1.6249	1.6249	1.6249
SON VEL,M/SEC	328.1	328.1	328.1	328.1	328.1	328.1	328.1

WARNING!! NO CONVERGENCE FOR u1= 1000.0
ANSWERS NOT RELIABLE, SOLUTION MAY NOT EXIST (SHCK)

SHOCKED GAS (2) --INCIDENT--EQUILIBRIUM

U2, M/SEC	703.53	666.91	576.09	560.23	549.01	540.16	532.35
P, BAR	0.08449	0.21842	0.32803	0.37372	0.41964	0.46673	0.51561
T, K	1371.90	1528.10	1816.96	1932.22	2043.84	2152.73	2258.45
RHO, KG/CU M	2.8607-2	6.6391-2	8.3844-2	8.9812-2	9.5312-2	1.0060-1	1.0586-1
H, KJ/KG	292.39	383.68	555.13	625.39	695.35	766.43	839.37
U, KJ/KG	-2.9743	54.682	163.89	209.27	255.08	302.48	352.28
G, KJ/KG	-7331.22	-7891.77	-9312.23	-9886.05	-10444.2	-10990.3	-11520.9
S, KJ/(KG) (K)	5.5570	5.4155	5.4307	5.4401	5.4503	5.4613	5.4729
M, (1/n)	38.619	38.619	38.614	38.608	38.597	38.580	38.552
(dLV/dLP)t	-1.00000	-1.00000	-1.00005	-1.00010	-1.00021	-1.00040	-1.00072
(dLV/dLT)p	1.0001	1.0002	1.0018	1.0037	1.0070	1.0123	1.0207
Cp, KJ/(KG) (K)	0.5827	0.5869	0.6041	0.6187	0.6412	0.6747	0.7226
GAMMAS	1.5861	1.5798	1.5570	1.5397	1.5162	1.4857	1.4497
SON VEL, M/SEC	684.5	720.9	780.5	800.4	817.0	830.2	840.3
P2/P1	6.654	8.192	12.302	14.016	15.738	17.504	19.337
T2/T1	4.656	5.094	6.057	6.441	6.813	7.176	7.528
M2/M1	1.0256	1.0256	1.0255	1.0253	1.0251	1.0246	1.0238
RHO2/RHO1	1.4214	1.6494	2.0830	2.2312	2.3679	2.4993	2.6299
V2, M/SEC	296.47	433.09	623.91	689.77	750.99	809.84	867.65

MOLE FRACTIONS

*Ar	9.2307-1	9.2306-1	9.2294-1	9.2280-1	9.2255-1	9.2213-1	9.2146-1
*H	6.3878-9	7.1872-8	4.2701-6	1.5520-5	4.7038-5	1.2367-4	2.8725-4
HO2	5.7290-9	2.4000-8	1.4081-7	2.4561-7	3.9562-7	5.9860-7	8.5747-7
*H2	3.2023-7	1.8716-6	3.5078-5	8.8322-5	1.9485-4	3.8722-4	7.0178-4
H2O	5.1272-2	5.1248-2	5.1025-2	5.0780-2	5.0378-2	4.9752-2	4.8831-2
H2O2	2.311-10	9.754-10	4.623 -9	7.549 -9	1.149 -8	1.654 -8	2.266 -8
*O	3.3351-7	2.0203-6	3.9781-5	1.0183-4	2.2822-4	4.6110-4	8.5170-4
*OH	1.8151-5	6.1566-5	4.2535-4	7.8035-4	1.3111-3	2.0550-3	3.0302-3
*O2	2.5636-2	2.5625-2	2.5530-2	2.5435-2	2.5293-2	2.5094-2	2.4835-2

* THERMODYNAMIC PROPERTIES FITTED TO 20000.K

PRODUCTS WHICH WERE CONSIDERED BUT WHOSE MOLE FRACTIONS
WERE LESS THAN 5.000000E-09 FOR ALL ASSIGNED CONDITIONS

O3 H2O (s) H2O (L)

SHOCK WAVE PARAMETERS ASSUMING
FROZEN COMPOSITION FOR INCIDENT SHOCKED CONDITIONS

CASE = 7

	REACTANT	MOLES		ENERGY	TEMP
				KJ/KG-MOL	K
NAME	H2	0.0500000		53.359	300.000
NAME	O2	0.0500000		54.358	300.000
NAME	Ar	0.9000000		38.455	300.000

O/F= 0.00000 %FUEL= 0.000000 R, EQ.RATIO= 0.500000 PHI, EQ.RATIO= 0.000000

INITIAL GAS (1)

MACH NUMBER1	3.0480	3.3528	3.6576	3.8100	3.9624	4.1148	4.2672
U1, M/SEC	1000.00	1100.00	1200.00	1250.00	1300.00	1350.00	1400.00
P, BAR	0.01333	0.02666	0.02666	0.02666	0.02666	0.02666	0.02666
T, K	300.00	300.00	300.00	300.00	300.00	300.00	300.00
RHO, KG/CU M	2.0126-2	4.0252-2	4.0252-2	4.0252-2	4.0252-2	4.0252-2	4.0252-2
H, KJ/KG	1.0622	1.0622	1.0622	1.0622	1.0622	1.0622	1.0622
U, KJ/KG	-65.182	-65.182	-65.182	-65.182	-65.182	-65.182	-65.182
G, KJ/KG	-1556.26	-1510.35	-1510.35	-1510.35	-1510.35	-1510.35	-1510.35
S, KJ/(KG) (K)	5.1911	5.0380	5.0380	5.0380	5.0380	5.0380	5.0380
M, (1/n)	37.654	37.654	37.654	37.654	37.654	37.654	37.654
Cp, KJ/(KG) (K)	0.5742	0.5742	0.5742	0.5742	0.5742	0.5742	0.5742
GAMMAS	1.6249	1.6249	1.6249	1.6249	1.6249	1.6249	1.6249
SON VEL, M/SEC	328.1	328.1	328.1	328.1	328.1	328.1	328.1

SHOCKED GAS (2) --INCIDENT--FROZEN

U2, M/SEC	317.26	332.77	349.41	358.06	366.89	375.87	384.99
P, BAR	0.15074	0.36638	0.43752	0.47544	0.51494	0.55601	0.59865
T, K	1076.14	1247.03	1433.31	1532.25	1635.05	1741.69	1852.17
RHO, KG/CU M	6.3438-2	1.3305-1	1.3824-1	1.4052-1	1.4263-1	1.4457-1	1.4637-1
H, KJ/KG	450.75	550.72	660.02	718.21	778.76	841.67	906.95
U, KJ/KG	213.13	275.36	343.52	379.87	417.72	457.08	497.97
G, KJ/KG	-5354.24	-6039.09	-6975.05	-7475.96	-7998.88	-8543.88	-9111.04
S, KJ/(KG) (K)	5.3943	5.2844	5.3269	5.3478	5.3684	5.3888	5.4088
M, (1/n)	37.654	37.654	37.654	37.654	37.654	37.654	37.654
Cp, KJ/(KG) (K)	0.5841	0.5858	0.5876	0.5886	0.5895	0.5904	0.5913
GAMMAS	1.6078	1.6049	1.6019	1.6005	1.5989	1.5974	1.5960
SON VEL, M/SEC	618.1	664.8	712.0	735.9	759.8	783.8	807.9

P2/P1	11.307	13.740	16.408	17.831	19.312	20.852	22.451
T2/T1	3.587	4.157	4.778	5.108	5.450	5.806	6.174
M2/M1	1.0000	1.0000	1.0000	1.0000	1.0000	1.0000	1.0000
RHO2/RHO1	3.1520	3.3056	3.4344	3.4911	3.5433	3.5917	3.6365
V2, M/SEC	682.74	767.23	850.59	891.94	933.11	974.13	1015.01

MOLE FRACTIONS

*H2	0.05000	0.05000	0.05000	0.05000	0.05000	0.05000	0.05000
*O2	0.05000	0.05000	0.05000	0.05000	0.05000	0.05000	0.05000
*Ar	0.90000	0.90000	0.90000	0.90000	0.90000	0.90000	0.90000

```

# EXAMPLE 8:
# (a) Rocket problem with infinite-area combustor (rocket iac by default).
# (b) The fuel is H2(L) at 20.27 K; the oxidant is O2(L) at 90.17 K.
# Both are in thermo.lib so that the enthalpies and "exploded" formulas
# do not need to be given.
# (c) The oxidant-to-fuel ratio is 5.55157 (o/f=5.55157).
# (d) The chamber pressure is 53.3172 bars (p,bar=53.3172).
# (e) Calculations are with equilibrium chemistry only (equilibrium).
# (f) For exit points there are three pressure ratios (pi/p=10,100,1000),
# one subsonic area ratio (subar=1.58), and three supersonic area
# ratios (supar=25,50,75).

```

```

      problem rocket equilibrium o/f=5.55157
case=8 p,bar=53.3172 subar=1.58,pi/p=10,100,1000,supar=25,50,75
      reactants
fuel = H2(L) wt% 100. t(k) 20.27
oxid = O2(L) wt% 100. t(k) 90.17
      output siunits
      end

```

```

OPTIONS: TP=F HP=F SP=F TV=F UV=F SV=F DETN=F SHOCK=F REFL=F INCD=F
RKT=T FROZ=F EQL=T IONS=F SIUNIT=T DEBUGF=F SHKDBG=F DETDBG=F TRNSPT=F

```

```

TRACE= 0.00E+00 S/R= 0.000000E+00 H/R= 0.000000E+00 U/R= 0.000000E+00

```

```

Pc,BAR = 53.317200

```

```

Pc/P = 10.0000 100.0000 1000.0000

```

```

SUBSONIC AREA RATIOS = 1.5800

```

```

SUPERSONIC AREA RATIOS = 25.0000 50.0000 75.0000

```

```

NFZ= 1 Mdot/Ac= 0.000000E+00 Ac/At= 0.000000E+00

```

REACTANT	WT.FRAC	(ENERGY/R),K	TEMP,K	DENSITY
EXPLODED FORMULA				
F: H2(L)	1.000000	-0.108389E+04	20.27	0.0000
H	2.00000			
O: O2(L)	1.000000	-0.156101E+04	90.17	0.0000
O	2.00000			

SPECIES BEING CONSIDERED IN THIS SYSTEM
(CONDENSED PHASE MAY HAVE NAME LISTED SEVERAL TIMES)

1 6/94 *H	1 5/89 HO2	tpis78 *H2
1 8/89 H2O	1 2/93 H2O2	1 1/90 *O
tpis78 *OH	tpis89 *O2	1 5/90 O3
1 8/89 H2O(s)	1 8/89 H2O(L)	

O/F = 5.551570

ENTHALPY (KG-MOL) (K) /KG	EFFECTIVE FUEL h(2)/R	EFFECTIVE OXIDANT h(1)/R	MIXTURE h0/R
	-0.53767500E+03	-0.48783267E+02	-0.12340534E+03
KG-FORM.WT./KG	bi(2)	bi(1)	b0i
*H	0.99212255E+00	0.00000000E+00	0.15143279E+00
*O	0.00000000E+00	0.62502344E-01	0.52962288E-01

POINT ITN	T	H	O
1 9	3389.270	-9.266	-16.561
Pinf/Pt = 1.737856			
2 4	3190.532	-9.433	-16.968
Pinf/Pt = 1.739443			
2 2	3190.207	-9.434	-16.968
3 4	2568.396	-9.922	-18.802
4 4	1759.119	-10.454	-23.533
5 4	1115.280	-10.958	-32.668
6 3	3360.178	-9.291	-16.616
6 2	3354.650	-9.295	-16.627
6 2	3353.978	-9.296	-16.628
6 1	3353.970	-9.296	-16.628
7 5	1441.190	-10.682	-26.980
7 2	1467.038	-10.662	-26.641
8 3	1241.429	-10.845	-30.099
8 2	1218.630	-10.864	-30.523

THEORETICAL ROCKET PERFORMANCE ASSUMING EQUILIBRIUM

COMPOSITION DURING EXPANSION FROM INFINITE AREA COMBUSTOR

Pinj = 773.3 PSIA
CASE = 8

REACTANT	WT FRACTION (SEE NOTE)	ENERGY KJ/KG-MOL	TEMP K
FUEL H2 (L)	1.0000000	-9012.000	20.270
OXIDANT O2 (L)	1.0000000	-12979.000	90.170

O/F= 5.55157 %FUEL= 15.263517 R,EQ.RATIO= 1.429629 PHI,EQ.RATIO= 1.429628

	CHAMBER	THROAT	EXIT	EXIT	EXIT	EXIT	EXIT	EXIT
Pinf/P	1.0000	1.7394	10.000	100.00	1000.00	1.1020	260.57	655.41
P, BAR	53.317	30.652	5.3317	0.53317	0.05332	48.381	0.20462	0.08135
T, K	3389.27	3190.21	2568.40	1759.12	1115.28	3353.97	1467.04	1218.63
RHO, KG/CU M	2.4071 0	1.4848 0	3.2770-1	4.8139-2	7.5938-3	2.2113 0	2.2155-2	1.0604-2
H, KJ/KG	-1026.05	-2210.09	-5432.07	-8564.25	-10623.5	-1239.91	-9535.06	-10313.3
U, KJ/KG	-3241.04	-4274.40	-7059.06	-9671.81	-11325.7	-3427.81	-10458.6	-11080.5
G, KJ/KG	-64259.7	-61729.8	-53350.7	-41384.1	-31431.3	-63814.9	-36905.6	-33049.3
S, KJ/(KG) (K)	18.6570	18.6570	18.6570	18.6570	18.6570	18.6570	18.6570	18.6570
M, (1/n)	12.723	12.849	13.125	13.206	13.207	12.746	13.207	13.207
(dLV/dLP)t	-1.01996	-1.01459	-1.00317	-1.00005	-1.00000	-1.01897	-1.00000	-1.00000
(dLV/dLT)p	1.3627	1.2808	1.0739	1.0017	1.0000	1.3482	1.0001	1.0000
Cp, KJ/(KG) (K)	8.2837	7.4299	4.8447	3.4332	2.9621	8.1390	3.2226	3.0413
GAMMAS	1.1449	1.1472	1.1732	1.2254	1.2699	1.1451	1.2429	1.2610
SON VEL, M/SEC	1592.4	1538.9	1381.6	1165.0	944.3	1582.8	1071.4	983.6
MACH NUMBER	0.000	1.000	2.149	3.333	4.640	0.413	3.850	4.382

PERFORMANCE PARAMETERS

Ae/At	1.0000	2.3489	12.225	68.680	1.5800	25.000	50.000
CSTAR, M/SEC	2333.4	2333.4	2333.4	2333.4	2333.4	2333.4	2333.4
CF	0.6595	1.2722	1.6640	1.8776	0.2803	1.7679	1.8470
Ivac, M/SEC	2880.3	3516.6	4168.1	4541.5	3999.5	4349.2	4487.8
Isp, M/SEC	1538.9	2968.5	3882.8	4381.2	654.0	4125.3	4309.8

MOLE FRACTIONS

*H	0.03390	0.02683	0.00797	0.00019	0.00000	0.03265	0.00001	0.00000
HO2	0.00002	0.00001	0.00000	0.00000	0.00000	0.00001	0.00000	0.00000
*H2	0.29410	0.29373	0.29695	0.30040	0.30052	0.29398	0.30051	0.30052
H2O	0.63643	0.65440	0.69081	0.69938	0.69948	0.63976	0.69948	0.69948
H2O2	0.00001	0.00000	0.00000	0.00000	0.00000	0.00001	0.00000	0.00000
*O	0.00214	0.00124	0.00007	0.00000	0.00000	0.00196	0.00000	0.00000
*OH	0.03162	0.02271	0.00413	0.00003	0.00000	0.02998	0.00000	0.00000
*O2	0.00179	0.00108	0.00007	0.00000	0.00000	0.00165	0.00000	0.00000

* THERMODYNAMIC PROPERTIES FITTED TO 20000.K

PRODUCTS WHICH WERE CONSIDERED BUT WHOSE MOLE FRACTIONS WERE LESS THAN 5.000000E-06 FOR ALL ASSIGNED CONDITIONS

O3 H2O(s) H2O(L)

NOTE. WEIGHT FRACTION OF FUEL IN TOTAL FUELS AND OF OXIDANT IN TOTAL OXIDANTS

3	3	1067.058	-11.004	-33.815
3	2	1087.734	-10.984	-33.311

THEORETICAL ROCKET PERFORMANCE ASSUMING EQUILIBRIUM
COMPOSITION DURING EXPANSION FROM INFINITE AREA COMBUSTOR

Pinj = 773.3 PSIA
CASE = 8

	REACTANT	WT FRACTION (SEE NOTE)	ENERGY KJ/KG-MOL	TEMP K
FUEL	H2 (L)	1.0000000	-9012.000	20.270
OXIDANT	O2 (L)	1.0000000	-12979.000	90.170

O/F= 5.55157 %FUEL= 15.263517 R,EQ.RATIO= 1.429629 PHI,EQ.RATIO= 1.429628

	CHAMBER	THROAT	EXIT
Pinf/P	1.0000	1.7394	1124.40
P, BAR	53.317	30.652	0.04742
T, K	3389.27	3190.21	1087.73
RHO, KG/CU M	2.4071 0	1.4848 0	6.9247-3
H, KJ/KG	-1026.05	-2210.09	-10704.9
U, KJ/KG	-3241.04	-4274.40	-11389.6
G, KJ/KG	-64259.7	-61729.8	-30998.7
S, KJ/(KG) (K)	18.6570	18.6570	18.6570
M, (1/n)	12.723	12.849	13.207
(dLV/dLP)t	-1.01996	-1.01459	-1.00000
(dLV/dLT)p	1.3627	1.2808	1.0000
Cp, KJ/(KG) (K)	8.2837	7.4299	2.9409
GAMMAS	1.1449	1.1472	1.2724
SON VEL,M/SEC	1592.4	1538.9	933.4
MACH NUMBER	0.000	1.000	4.714

PERFORMANCE PARAMETERS

Ae/At	1.0000	75.000
CSTAR, M/SEC	2333.4	2333.4
CF	0.6595	1.8856
Ivac, M/SEC	2880.3	4555.4
Isp, M/SEC	1538.9	4399.7

MOLE FRACTIONS

*H	0.03390	0.02683	0.00000
HO2	0.00002	0.00001	0.00000
*H2	0.29410	0.29373	0.30052
H2O	0.63643	0.65440	0.69948
H2O2	0.00001	0.00000	0.00000
*O	0.00214	0.00124	0.00000
*OH	0.03162	0.02271	0.00000
*O2	0.00179	0.00108	0.00000

* THERMODYNAMIC PROPERTIES FITTED TO 20000.K

PRODUCTS WHICH WERE CONSIDERED BUT WHOSE MOLE FRACTIONS
WERE LESS THAN 5.000000E-06 FOR ALL ASSIGNED CONDITIONS

O3 H2O(s) H2O(L)

NOTE. WEIGHT FRACTION OF FUEL IN TOTAL FUELS AND OF OXIDANT IN TOTAL OXIDANTS

```
# EXAMPLE 9:
# (a) Rocket problem with a finite-area combustor (rocket fac).
# (b) Contraction ratio of 1.58 (acat=1.58) is assigned.
# (c) Fuel, oxidant, and the remaining parameters are the same as in
# example 8.
```

```
reac fuel = H2(L) wt%=100. t,k= 20.27
      oxid = O2(L) wt%=100. t,k= 90.17
problem o/f=5.55157 case=9 rocket fac p,bar=53.3172 acat=1.58
      pi/p=10,100,1000, supar=25,50,75
output siunits
end
```

```
OPTIONS: TP=F HP=F SP=F TV=F UV=F SV=F DETN=F SHOCK=F REFL=F INCD=F
RKT=T FROZ=F EQL=T IONS=F SIUNIT=T DEBUGF=F SHKDBG=F DETDBG=F TRNSPT=F
```

```
TRACE= 0.00E+00 S/R= 0.000000E+00 H/R= 0.000000E+00 U/R= 0.000000E+00
```

```
Pc, BAR = 53.317200
```

```
Pc/P = 10.0000 100.0000 1000.0000
```

```
SUBSONIC AREA RATIOS =
```

```
SUPERSONIC AREA RATIOS = 25.0000 50.0000 75.0000
```

```
NFZ= 1 Mdot/Ac= 0.000000E+00 Ac/At= 1.580000E+00
```

REACTANT	WT. FRAC	(ENERGY/R), K	TEMP, K	DENSITY
EXPLODED FORMULA				
F: H2(L)	1.000000	-0.108389E+04	20.27	0.0000
H 2.00000				
O: O2(L)	1.000000	-0.156101E+04	90.17	0.0000
O 2.00000				

```
SPECIES BEING CONSIDERED IN THIS SYSTEM
(CONDENSED PHASE MAY HAVE NAME LISTED SEVERAL TIMES)
```

1 6/94 *H	1 5/89 HO2	tpis78 *H2
1 8/89 H2O	1 2/93 H2O2	1 1/90 *O
tpis78 *OH	tpis89 *O2	1 5/90 O3
1 8/89 H2O(s)	1 8/89 H2O(L)	

```
O/F = 5.551570
```

ENTHALPY	EFFECTIVE FUEL	EFFECTIVE OXIDANT	MIXTURE
(KG-MOL) (K) /KG	h(2)/R	h(1)/R	h0/R
	-0.53767500E+03	-0.48783267E+02	-0.12340534E+03
KG-FORM. WT. /KG	bi(2)	bi(1)	b0i
*H	0.99212255E+00	0.00000000E+00	0.15143279E+00
*O	0.00000000E+00	0.62502344E-01	0.52962288E-01

POINT	ITN	T	H	O
1	9	3389.270	-9.266	-16.561
2	3	3381.326	-9.303	-16.578
Pinf/Pt = 1.737476				
3	4	3134.432	-9.471	-16.983
Pinf/Pt = 1.739009				
3	2	3184.121	-9.471	-16.984
4	3	3352.506	-9.328	-16.634
4	2	3347.029	-9.332	-16.644
4	2	3346.363	-9.333	-16.645
4	1	3346.355	-9.333	-16.645
2	1	3381.345	-9.303	-16.578
Pinf/Pt = 1.737477				
3	4	3184.446	-9.471	-16.983
Pinf/Pt = 1.739010				
3	2	3184.135	-9.471	-16.984
4	3	3352.524	-9.327	-16.634
4	2	3347.047	-9.332	-16.644
4	2	3346.381	-9.333	-16.645
4	1	3346.373	-9.333	-16.645
END OF CHAMBER ITERATIONS				
4	5	2596.353	-9.941	-18.697
5	4	1786.498	-10.478	-23.297
6	4	1135.439	-10.981	-32.218
7	5	1442.273	-10.724	-26.966
7	2	1468.448	-10.704	-26.623
8	3	1242.967	-10.885	-30.071
8	2	1219.873	-10.905	-30.499

THEORETICAL ROCKET PERFORMANCE ASSUMING EQUILIBRIUM

COMPOSITION DURING EXPANSION FROM FINITE AREA COMBUSTOR

Pinj = 773.3 PSIA
 Ac/At = 1.5800 Pinj/Pinf = 1.084780
 CASE = 9

	REACTANT	WT FRACTION (SEE NOTE)	ENERGY KJ/KG-MOL	TEMP K
FUEL	H2 (L)	1.0000000	-9012.000	20.270
OXIDANT	O2 (L)	1.0000000	-12979.000	90.170

O/F= 5.55157 %FUEL= 15.263517 R,EQ.RATIO= 1.429629 PHI,EQ.RATIO= 1.429628

	INJECTOR	COMB END	THROAT	EXIT	EXIT	EXIT	EXIT	EXIT
Pinj/P	1.0000	1.1954	1.8864	10.000	100.00	1000.00	282.15	709.71
P, BAR	53.317	44.602	28.263	5.3317	0.53317	0.05332	0.18897	0.07513
T, K	3389.27	3346.37	3184.14	2596.35	1786.50	1135.44	1468.45	1219.87
RHO, KG/CU M	2.4071 0	2.0416 0	1.3709 0	3.2390-1	4.7400-2	7.4589-3	2.0441-2	9.7824-3
H, KJ/KG	-1026.05	-1239.49	-2207.90	-5294.68	-8469.93	-10563.7	-9530.50	-10309.5
U, KJ/KG	-3241.04	-3424.10	-4269.63	-6940.78	-9594.77	-11278.5	-10455.0	-11077.5
G, KJ/KG	-64259.7	-63850.8	-61783.7	-53873.0	-41895.7	-31808.0	-37005.5	-33133.6
S, KJ/(KG) (K)	18.6570	18.7102	18.7102	18.7102	18.7102	18.7102	18.7102	18.7102
M, (1/n)	12.723	12.736	12.841	13.114	13.205	13.207	13.207	13.207
(dLV/dLP)t	-1.01996	-1.01940	-1.01495	-1.00361	-1.00007	-1.00000	-1.00000	-1.00000
(dLV/dLT)p	1.3627	1.3567	1.2882	1.0834	1.0022	1.0000	1.0001	1.0000
Cp, KJ/(KG) (K)	8.2837	8.2508	7.5303	4.9862	3.4569	2.9777	3.2237	3.0422
GAMMAS	1.1449	1.1445	1.1465	1.1705	1.2238	1.2681	1.2428	1.2609
SON VEL, M/SEC	1592.4	1581.2	1537.4	1388.1	1173.3	952.1	1071.9	984.0
MACH NUMBER	0.000	0.413	1.000	2.105	3.289	4.587	3.848	4.379

PERFORMANCE PARAMETERS

Ae/At	1.5800	1.0000	2.2270	11.524	64.695	25.000	50.000
CSTAR, M/SEC	2332.1	2332.1	2332.1	2332.1	2332.1	2332.1	2332.1
CF	0.2802	0.6593	1.2529	1.6545	1.8728	1.7685	1.8477
Ivac, M/SEC	3997.0	2878.5	3485.2	4150.0	4531.2	4348.3	4487.2
Isp, M/SEC	653.4	1537.4	2921.9	3858.5	4367.5	4124.2	4308.9

MOLE FRACTIONS

*H	0.03390	0.03336	0.02747	0.00893	0.00024	0.00000	0.00002	0.00000
HO2	0.00002	0.00001	0.00001	0.00000	0.00000	0.00000	0.00000	0.00000
*H2	0.29410	0.29384	0.29358	0.29659	0.30037	0.30052	0.30051	0.30052
H2O	0.63643	0.63858	0.65337	0.68952	0.69935	0.69948	0.69948	0.69948
H2O2	0.00001	0.00001	0.00000	0.00000	0.00000	0.00000	0.00000	0.00000
*O	0.00214	0.00204	0.00130	0.00009	0.00000	0.00000	0.00000	0.00000
*OH	0.03162	0.03045	0.02314	0.00477	0.00004	0.00000	0.00000	0.00000
*O2	0.00179	0.00172	0.00113	0.00009	0.00000	0.00000	0.00000	0.00000

* THERMODYNAMIC PROPERTIES FITTED TO 20000.K

PRODUCTS WHICH WERE CONSIDERED BUT WHOSE MOLE FRACTIONS
WERE LESS THAN 5.000000E-06 FOR ALL ASSIGNED CONDITIONS

O3 H2O(s) H2O(L)

NOTE. WEIGHT FRACTION OF FUEL IN TOTAL FUELS AND OF OXIDANT IN TOTAL OXIDANTS

4	3	1067.940	-11.046	-33.793
4	2	1088.883	-11.025	-33.283

THEORETICAL ROCKET PERFORMANCE ASSUMING EQUILIBRIUM
COMPOSITION DURING EXPANSION FROM FINITE AREA COMBUSTOR

Pinj = 773.3 PSIA
Ac/At = 1.5800 Pinj/Pinf = 1.084780
CASE = 9

	REACTANT	WT FRACTION (SEE NOTE)	ENERGY KJ/KG-MOL	TEMP K
FUEL	H2 (L)	1.0000000	-9012.000	20.270
OXIDANT	O2 (L)	1.0000000	-12979.000	90.170

O/F= 5.55157 %FUEL= 15.263517 R, EQ. RATIO= 1.429629 PHI, EQ. RATIO= 1.429628

	INJECTOR	COMB END	THROAT	EXIT
Pinj/P	1.0000	1.1954	1.8864	1217.53
P, BAR	53.317	44.602	28.263	0.04379
T, K	3389.27	3346.37	3184.14	1088.88
RHO, KG/CU M	2.4071 0	2.0416 0	1.3709 0	6.3882-3
H, KJ/KG	-1026.05	-1239.49	-2207.90	-10701.5
U, KJ/KG	-3241.04	-3424.10	-4269.63	-11387.0
G, KJ/KG	-64259.7	-63850.8	-61783.7	-31074.7
S, KJ/(KG) (K)	18.6570	18.7102	18.7102	18.7102
M, (1/n)	12.723	12.736	12.841	13.207
(dLV/dLP)t	-1.01996	-1.01940	-1.01495	-1.00000
(dLV/dLT)p	1.3627	1.3567	1.2882	1.0000
Cp, KJ/(KG) (K)	8.2837	8.2508	7.5303	2.9418
GAMMAS	1.1449	1.1445	1.1465	1.2723
SON VEL, M/SEC	1592.4	1581.2	1537.4	933.9
MACH NUMBER	0.000	0.413	1.000	4.710

PERFORMANCE PARAMETERS

Ae/At	1.5800	1.0000	75.000
CSTAR, M/SEC	2332.1	2332.1	2332.1
CF	0.2802	0.6593	1.8863
Ivac, M/SEC	3997.0	2878.5	4554.8
Isp, M/SEC	653.4	1537.4	4399.0

MOLE FRACTIONS

*H	0.03390	0.03336	0.02747	0.00000
HO2	0.00002	0.00001	0.00001	0.00000
*H2	0.29410	0.29384	0.29358	0.30052
H2O	0.63643	0.63858	0.65337	0.69948
H2O2	0.00001	0.00001	0.00000	0.00000
*O	0.00214	0.00204	0.00130	0.00000
*OH	0.03162	0.03045	0.02314	0.00000
*O2	0.00179	0.00172	0.00113	0.00000

* THERMODYNAMIC PROPERTIES FITTED TO 20000.K

PRODUCTS WHICH WERE CONSIDERED BUT WHOSE MOLE FRACTIONS
WERE LESS THAN 5.000000E-06 FOR ALL ASSIGNED CONDITIONS

O3 H2O(s) H2O(L)
NOTE. WEIGHT FRACTION OF FUEL IN TOTAL FUELS AND OF OXIDANT IN TOTAL OXIDANTS

```
# EXAMPLE 10:  
# (a) Rocket problem with a finite-area combustor (rocket fac).  
# (b) A ratio of mass flow rate to chamber area of 1333.9 (ma=1333.9)  
# is assigned. This value was calculated from the results  
# of example 9 where a contraction ratio of 1.58 was assigned.  
# (c) Fuel, oxidant, and the remaining parameters are the same as in  
# examples 8 and 9.
```

```
reac fuel = H2(L) t,k= 20.27  
oxid = O2(L) t,k= 90.17  
problem o/f=5.55157 case=10 rocket fac p,bar=53.3172 ma=1333.9  
pi/p=10,100,1000, sup-ae/at=25,50,75  
output short  
end
```

```
WARNING!! AMOUNT MISSING FOR REACTANT 1.  
PROGRAM SETS WEIGHT PERCENT = 100. (REACT)
```

```
WARNING!! AMOUNT MISSING FOR REACTANT 2.  
PROGRAM SETS WEIGHT PERCENT = 100. (REACT)
```

THEORETICAL ROCKET PERFORMANCE ASSUMING EQUILIBRIUM
COMPOSITION DURING EXPANSION FROM FINITE AREA COMBUSTOR

Pinj = 773.3 PSIA
 MDOT/AC = 1333.500 (KG/S)/M**2 Pinj/Pinf = 1.084780
 CASE = 10

	REACTANT	WT FRACTION (SEE NOTE)	ENERGY KJ/KG-MOL	TEMP K
FUEL	H2 (L)	1.0000000	-9012.000	20.270
OXIDANT	O2 (L)	1.0000000	-12979.000	90.170

O/F= 5.55157 %FUEL= 15.263517 R,EQ.RATIO= 1.429629 PHI,EQ.RATIO= 1.429628

	INJECTOR	COMB END	THROAT	EXIT	EXIT	EXIT	EXIT	EXIT
Pinj/P	1.0000	1.1954	1.8864	10.000	100.00	1000.00	282.15	709.71
P, BAR	53.317	44.602	28.263	5.3317	0.53317	0.05332	0.18897	0.07513
T, K	3389.27	3346.37	3184.14	2596.35	1786.50	1135.44	1468.45	1219.87
RHO, KG/CU M	2.4071 0	2.0417 0	1.3709 0	3.2390-1	4.7400-2	7.4589-3	2.0441-2	9.7824-3
H, KJ/KG	-1026.05	-1239.48	-2207.90	-5294.68	-8469.93	-10563.7	-9530.50	-10309.5
U, KJ/KG	-3241.04	-3424.09	-4269.63	-6940.78	-9594.77	-11278.5	-10455.0	-11077.5
G, KJ/KG	-64259.7	-63850.8	-61783.7	-53873.0	-41895.7	-31808.0	-37005.5	-33133.6
S, KJ/(KG) (K)	18.6570	18.7102	18.7102	18.7102	18.7102	18.7102	18.7102	18.7102
M, (1/n)	12.723	12.736	12.841	13.114	13.205	13.207	13.207	13.207
(dLV/dLP)t	-1.01996	-1.01940	-1.01495	-1.00361	-1.00007	-1.00000	-1.00000	-1.00000
(dLV/dLT)p	1.3627	1.3567	1.2882	1.0834	1.0022	1.0000	1.0001	1.0000
Cp, KJ/(KG) (K)	8.2837	8.2508	7.5303	4.9862	3.4569	2.9777	3.2237	3.0422
GAMMAS	1.1449	1.1445	1.1465	1.1705	1.2238	1.2681	1.2428	1.2609
SON VEL, M/SEC	1592.4	1581.2	1537.4	1388.1	1173.3	952.1	1071.9	984.0
MACH NUMBER	0.000	0.413	1.000	2.105	3.289	4.587	3.848	4.379

PERFORMANCE PARAMETERS

Ae/At	1.5800	1.0000	2.2270	11.524	64.695	25.000	50.000
CSTAR, M/SEC	2332.1	2332.1	2332.1	2332.1	2332.1	2332.1	2332.1
CF	0.2802	0.6593	1.2529	1.6545	1.8728	1.7685	1.8477
Ivac, M/SEC	3997.1	2878.5	3485.2	4150.0	4531.2	4348.3	4487.2
Isp, M/SEC	653.3	1537.4	2921.9	3858.5	4367.5	4124.2	4308.9

MOLE FRACTIONS

*H	0.03390	0.03336	0.02747	0.00893	0.00024	0.00000	0.00002	0.00000
HO2	0.00002	0.00001	0.00001	0.00000	0.00000	0.00000	0.00000	0.00000
*H2	0.29410	0.29384	0.29358	0.29659	0.30037	0.30052	0.30051	0.30052
H2O	0.63643	0.63858	0.65337	0.68952	0.69935	0.69948	0.69948	0.69948
H2O2	0.00001	0.00001	0.00000	0.00000	0.00000	0.00000	0.00000	0.00000
*O	0.00214	0.00204	0.00130	0.00009	0.00000	0.00000	0.00000	0.00000
*OH	0.03162	0.03045	0.02314	0.00477	0.00004	0.00000	0.00000	0.00000
*O2	0.00179	0.00172	0.00113	0.00009	0.00000	0.00000	0.00000	0.00000

* THERMODYNAMIC PROPERTIES FITTED TO 20000.K

NOTE. WEIGHT FRACTION OF FUEL IN TOTAL FUELS AND OF OXIDANT IN TOTAL OXIDANTS

THEORETICAL ROCKET PERFORMANCE ASSUMING EQUILIBRIUM
COMPOSITION DURING EXPANSION FROM FINITE AREA COMBUSTOR

Pinj = 773.3 PSIA
MDOI/Ac = 1333.900 (KG/S)/M**2 Pinj/Pinf = 1.084780
CASE = 10

	REACTANT	WT FRACTION (SEE NOTE)	ENERGY KJ/KG-MOL	TEMP K
FUEL	H2(L)	1.0000000	-9012.000	20.270
OXIDANT	O2(L)	1.0000000	-12979.000	90.170

O/F= 5.55157 %FUEL= 15.263517 R, EQ. RATIO= 1.429629 PHI, EQ. RATIO= 1.429628

	INJECTOR	COMB END	THROAT	EXIT
Pinj/P	1.0000	1.1954	1.8864	1217.53
P, BAR	53.317	44.602	28.263	0.04379
T, K	3389.27	3346.37	3184.14	1088.88
RHO, KG/CU M	2.4071 0	2.0417 0	1.3709 0	6.3882-3
H, KJ/KG	-1026.05	-1239.48	-2207.90	-10701.5
U, KJ/KG	-3241.04	-3424.09	-4269.63	-11387.0
G, KJ/KG	-64259.7	-63850.8	-61783.7	-31074.7
S, KJ/(KG) (K)	18.6570	18.7102	18.7102	18.7102
M, (1/n)	12.723	12.736	12.841	13.207
(dLV/dLP)t	-1.01996	-1.01940	-1.01495	-1.00000
(dLV/dLT)p	1.3627	1.3567	1.2882	1.0000
Cp, KJ/(KG) (K)	8.2837	8.2508	7.5303	2.9418
GAMMAS	1.1449	1.1445	1.1465	1.2723
SON VEL, M/SEC	1592.4	1581.2	1537.4	933.9
MACH NUMBER	0.000	0.413	1.000	4.710

PERFORMANCE PARAMETERS

Ae/At	1.5800	1.0000	75.000
CSTAR, M/SEC	2332.1	2332.1	2332.1
CF	0.2802	0.6593	1.8863
Ivac, M/SEC	3997.1	2878.5	4554.8
Isp, M/SEC	653.3	1537.4	4399.0

MOLE FRACTIONS

*H	0.03390	0.03336	0.02747	0.00000
HO2	0.00002	0.00001	0.00001	0.00000
*H2	0.29410	0.29384	0.29358	0.30052
H2O	0.63643	0.63858	0.65337	0.69948
H2O2	0.00001	0.00001	0.00000	0.00000
*O	0.00214	0.00204	0.00130	0.00000
*OH	0.03162	0.03045	0.02314	0.00000
*O2	0.00179	0.00172	0.00113	0.00000

* THERMODYNAMIC PROPERTIES FITTED TO 20000.K

NOTE. WEIGHT FRACTION OF FUEL IN TOTAL FUELS AND OF OXIDANT IN TOTAL OXIDANTS

```

# EXAMPLE 11:
# (a) Rocket problem with an infinite-area combustor (rocket).
# (b) Reactants are Li(cr) at 298.15 K and F2(L) at 85.02 K.
#     Enthalpies and "exploded" formulas are to be taken from
#     thermo.lib. Thus this information is not given.
# (c) Relative amounts of reactants are given as moles.
# (d) Chamber pressure is 1000 psia (p,psia =1000).
# (e) Ionized species are to be included in the products (ions).
# (f) Only equilibrium calculations are to be performed (equilibrium).
# (g) For exit points, one pressure ratio (pi/p=68.0457), one
#     subsonic area ratio (sub,ae/at=10), and three supersonic area ratios
#     (sup,ae/at=10,20,100) are to be included.

```

```

react fuel = Li(cr) moles= 1.    t(k)=298.15
      oxid = F2(L)  moles= .5556  t(k)=85.02
prob   case=11 rocket equilibrium p,psia=1000 ions
      pi/p=68.0457, sub,ae/at=10, sup,ae/at=10,20,100
output siunits transport
end

```

```

OPTIONS: TP=F HP=F SP=F TV=F UV=F SV=F DETN=F SHOCK=F REFL=F INCD=F
RKT=T FROZ=F EQL=T IONS=T SIUNIT=T DEBUGF=F SHKDBG=F DETDBG=F TRNSPT=T

```

```

TRACE= 0.00E+00 S/R= 0.000000E+00 H/R= 0.000000E+00 U/R= 0.000000E+00

```

```

Pc,BAR = 68.947304

```

```

Pc/P = 68.0457

```

```

SUBSONIC AREA RATIOS = 10.0000

```

```

SUPERSONIC AREA RATIOS = 10.0000 20.0000 100.0000

```

```

NFZ= 1 Mdot/Ac= 0.000000E+00 Ac/At= 0.000000E+00

```

REACTANT	MOLES	(ENERGY/R),K	TEMP,K	DENSITY
EXPLODED FORMULA				
F: Li(cr)	1.000000	-0.298149E-06	298.15	0.0000
LI	1.00000			
O: F2(L)	0.555600	-0.157448E+04	85.02	0.0000
F	2.00000			

THEORETICAL ROCKET PERFORMANCE ASSUMING EQUILIBRIUM
COMPOSITION DURING EXPANSION FROM INFINITE AREA COMBUSTOR

Pinj = 1000.0 PSIA
CASE = 11

	REACTANT	MOLES	ENERGY KJ/KG-MOL	TEMP K
FUEL	Li(cr)	1.0000000	0.000	298.150
OXIDANT	F2(L)	0.5556000	-13091.000	85.020

O/F= 3.04150 %FUEL= 24.743311 R, EQ. RATIO= 0.899928 PHI, EQ. RATIO= 0.899928

	CHAMBER	THROAT	EXIT	EXIT	EXIT	EXIT	EXIT
Pinf/P	1.0000	1.7560	68.046	1.0021	73.493	188.51	1585.57
P, BAR	68.947	39.263	1.0132	68.804	0.93814	0.36576	0.04348
T, K	5685.66	5335.82	3508.75	5684.30	3468.47	2916.48	1952.61
RHO, KG/CU M	3.1988 0	1.9836 0	8.6962-2	3.1931 0	8.1552-2	3.8114-2	6.9320-3
H, KJ/KG	-259.28	-1422.40	-7051.17	-263.77	-7140.33	-8135.15	-9782.87
U, KJ/KG	-2414.71	-3401.82	-8216.33	-2418.51	-8290.70	-9094.79	-10410.2
G, KJ/KG	-64713.0	-61910.3	-46827.1	-64702.2	-46459.6	-41197.0	-31918.0
S, KJ/(KG) (K)	11.3362	11.3362	11.3362	11.3362	11.3362	11.3362	11.3362
M, (1/n)	21.932	22.413	25.038	21.934	25.069	25.269	25.881
(dLV/dLP)t	-1.08286	-1.07324	-1.00885	-1.08283	-1.00782	-1.00183	-1.02364
(dLV/dLT)p	2.0665	1.9980	1.1726	2.0663	1.1530	1.0248	1.3639
Cp, KJ/(KG) (K)	6.8472	6.6601	2.6365	6.8467	2.5114	1.6054	3.2529
GAMMAS	1.1814	1.1752	1.1967	1.1814	1.2016	1.2714	1.1906
SON VEL, M/SEC	1595.8	1525.2	1180.8	1595.5	1175.7	1104.6	864.2
MACH NUMBER	0.000	1.000	3.121	0.059	3.155	3.593	5.050

TRANSPORT PROPERTIES (GASES ONLY)

CONDUCTIVITY IN UNITS OF MILLIWATTS/(CM) (K)

VISC, MILLIPOISE	1.4392	1.3862	1.0809	1.4390	1.0729	0.95570	0.72997
------------------	--------	--------	--------	--------	--------	---------	---------

WITH EQUILIBRIUM REACTIONS

Cp, KJ/(KG) (K)	6.8472	6.6601	2.6365	6.8467	2.5114	1.6054	3.2529
CONDUCTIVITY	14.6729	13.8861	4.3181	14.6703	4.0680	2.1692	2.7591
PRANDTL NUMBER	0.6716	0.6648	0.6599	0.6716	0.6624	0.7073	0.8606

WITH FROZEN REACTIONS

Cp, KJ/(KG) (K)	1.5912	1.5704	1.4855	1.5912	1.4844	1.4713	1.4523
CONDUCTIVITY	2.9867	2.8786	2.2503	2.9863	2.2332	1.9786	1.4809
PRANDTL NUMBER	0.7668	0.7562	0.7135	0.7667	0.7132	0.7107	0.7158

PERFORMANCE PARAMETERS

Ae/At	1.0000	9.4392	10.000	10.000	20.000	100.00
CSTAR, M/SEC	2279.0	2279.0	2279.0	2279.0	2279.0	2279.0
CF	0.6692	1.6172	0.0416	1.6278	1.7415	1.9150
Ivac, M/SEC	2823.0	4001.8	22837.2	4019.8	4210.6	4508.0
Isp, M/SEC	1525.2	3685.6	94.7	3709.7	3968.8	4364.3

MOLE FRACTIONS

*e-	0.00292	0.00235	0.00009	0.00292	0.00008	0.00000	0.00000
F	0.21188	0.19608	0.10774	0.21183	0.10670	0.10058	0.10259
F-	0.00465	0.00365	0.00028	0.00465	0.00026	0.00004	0.00000
F2	0.00002	0.00001	0.00000	0.00002	0.00000	0.00000	0.00000
*Li	0.12161	0.10469	0.00840	0.12155	0.00725	0.00041	0.00000
*Li+	0.00758	0.00601	0.00038	0.00757	0.00034	0.00004	0.00000
LiF	0.65001	0.68614	0.88242	0.65015	0.88468	0.89754	0.87248
Li2	0.00022	0.00011	0.00000	0.00022	0.00000	0.00000	0.00000
Li2F2	0.00109	0.00096	0.00068	0.00109	0.00070	0.00140	0.02465
Li3F3	0.00000	0.00000	0.00000	0.00000	0.00000	0.00000	0.00028

* THERMODYNAMIC PROPERTIES FITTED TO 20000.K

PRODUCTS WHICH WERE CONSIDERED BUT WHOSE MOLE FRACTIONS
WERE LESS THAN 5.000000E-06 FOR ALL ASSIGNED CONDITIONS

F+	LiF2-	Li(cr)	Li(L)	LiF(s)
LiF(L)				

```

# EXAMPLE 12:
# (a) Infinite-area rocket problem (rocket).
# (b) The fuel is monomethyl hydrazine (CH6N2(L)) and the oxidant is
# nitrogen tetroxide (N2O4(L)) at 298.15 K. Enthalpies and
# "exploded" formulas are to be taken from thermo.lib.
# (c) The density of the reactant mixture is desired. This requires
# the individual densities be given with the reactant data
# (rho,g/cc = .874 and rho,g/cc == 1.431).
# (d) The oxidant-to-fuel weight ratio is 2.5 (o/f=2.5).
# (e) Chamber pressure is 1000 psia (p,psia=1000).
# (f) Equilibrium and frozen calculations are to be performed with
# freezing at the throat (nfz=2).
# (g) For exit points one pressure ratio (pi/p=68.0457) and four
# supersonic area ratios (supersonic=10,50,100,200) are given.

react fuel = CH6N2(L)      rho,g/cc = .874
      oxid = N2O4(L)      rho,g/cc = 1.431
prob  rocket case=12 p,psia=1000, pi/p=68.0457, eql frozen nfz=2
      supersonic=5,10,25,50,75,100,150,200, o/f= 2.5,
only  CO   CO2  H   HNO  HNO2 HO2  H2   H2O  H2O2  N   NO   NO2
      N2   N2O  O  OH  O2   HCO  NH   CH4  NH2  NH3  H2O(L) C(gr)
output siunits massf plot aeat t p ivac isp mach cf
end

OPTIONS: TP=F HP=F SP=F TV=F UV=F SV=F DETN=F SHOCK=F REFL=F INCD=F
RKT=T FROZ=T EQL=T IONS=F SIUNIT=T DEBUGF=F SHKDBG=F DETDBG=F TRNSPT=F

TRACE= 0.00E+00 S/R= 0.000000E+00 H/R= 0.000000E+00 U/R= 0.000000E+00

Pc,BAR = 68.947304

Pc/P = 68.0457

SUBSONIC AREA RATIOS =

SUPERSONIC AREA RATIOS = 5.0000 10.0000 25.0000 50.0000 75.0000
100.0000 150.0000 200.0000

NFZ= 2 Mdot/Ac= 0.000000E+00 Ac/At= 0.000000E+00

WARNING!! AMOUNT MISSING FOR REACTANT 1.
PROGRAM SETS WEIGHT PERCENT = 100. (REACT)

WARNING!! AMOUNT MISSING FOR REACTANT 2.
PROGRAM SETS WEIGHT PERCENT = 100. (REACT)

      REACTANT      WT.FRAC  (ENERGY/R),K  TEMP,K  DENSITY
      EXPLODED FORMULA
F: CH6N2(L)      1.000000  0.651872E+04  298.15  0.8740
      C 1.000000  H 6.000000  N 2.000000
O: N2O4(L)      1.000000  -0.211065E+04  298.15  1.4310
      N 2.000000  O 4.000000

```

SPECIES BEING CONSIDERED IN THIS SYSTEM
(CONDENSED PHASE MAY HAVE NAME LISTED SEVERAL TIMES)

1 8/88 CH4	tpis79 *CO	1 7/88 *CO2
1 6/94 *H	l12/89 HCO	l12/89 HNO
tpis89 HNO2	1 5/89 HO2	tpis78 *H2
1 8/89 H2O	1 2/93 H2O2	1 6/88 *N
l11/89 *NH	l12/89 NH2	tpis89 NH3
tpis89 *NO	1 7/88 NO2	tpis78 *N2
1 7/88 N2O	1 1/90 *O	tpis78 *OH
tpis89 *O2	x 4/83 C(gr)	x 4/83 C(gr)
x 4/83 C(gr)	1 8/89 H2O(L)	

O/F = 2.500000

ENTHALPY (KG-MOL) (K) /KG	EFFECTIVE FUEL h(2) /R	EFFECTIVE OXIDANT h(1) /R	MIXTURE h0/R
	0.14148957E+03	-0.22939058E+02	0.24040550E+02
KG-FORM.WT. /KG	bi(2)	bi(1)	b0i
C	0.21705101E-01	0.00000000E+00	0.62014573E-02
*H	0.13023060E+00	0.00000000E+00	0.37208744E-01
*N	0.43410201E-01	0.21736513E-01	0.27928995E-01
*O	0.00000000E+00	0.43473025E-01	0.31052161E-01

POINT ITN	T	C	H	N	O
1 10	3386.569	-17.018	-10.171	-12.866	-15.018
Pinf/Pt = 1.733517					
2 3	3207.237	-17.495	-10.420	-13.029	-15.222
Pinf/Pt = 1.731796					
2 2	3207.551	-17.494	-10.420	-13.029	-15.222
3 5	2173.122	-21.717	-12.457	-14.122	-17.057
4 4	2400.051	-20.495	-11.908	-13.886	-16.543
4 3	2422.435	-20.386	-11.858	-13.861	-16.496
4 1	2422.478	-20.386	-11.858	-13.861	-16.496
5 4	2171.383	-21.727	-12.462	-14.124	-17.061
5 2	2175.478	-21.703	-12.451	-14.120	-17.051
6 4	1843.631	-24.075	-13.429	-14.421	-17.925
6 2	1840.505	-24.102	-13.439	-14.424	-17.934
7 4	1580.708	-27.097	-14.543	-14.630	-18.600
7 2	1583.036	-27.061	-14.530	-14.628	-18.595
8 3	1440.447	-29.620	-15.403	-14.741	-18.819
8 2	1438.100	-29.669	-15.419	-14.743	-18.822

THEORETICAL ROCKET PERFORMANCE ASSUMING EQUILIBRIUM

COMPOSITION DURING EXPANSION FROM INFINITE AREA COMBUSTOR

Pinj = 1000.0 P:IA
CASE = 12

	REACTANT	WT FRACTION (SEE NOTE)	ENERGY KJ/KG-MOL	TEMP K
FUEL	CH6N2 (L)	1.0000000	54200.000	298.150
OXIDANT	N2O4 (L)	1.0000000	-17549.000	298.150

REACTANT DENSITY= 1210.57 KG/CU M

O/F= 2.50000 %FUEL= 28.571429 R,EQ.RATIO= 0.998555 PHI,EQ.RATIO= 0.998555

	CHAMBER	THROAT	EXIT	EXIT	EXIT	EXIT	EXIT	EXIT
Pinf/P	1.0000	1.7318	68.046	27.260	67.469	219.62	537.92	910.15
P, BAR	68.947	39.813	1.0132	2.5292	1.0219	0.31394	0.12817	0.07575
T, K	3386.57	3207.55	2173.12	2422.48	2175.48	1840.51	1583.04	1438.10
RHO, KG/CU M	5.8414 0	3.6029 0	1.4329-1	3.1771-1	1.4434-1	5.2779-2	2.5095-2	1.6331-2
H, KJ/KG	199.89	-427.33	-3713.93	-3026.58	-3707.90	-4476.65	-4971.56	-5227.72
U, KJ/KG	-980.43	-1532.34	-4421.09	-3822.66	-4415.88	-5071.46	-5482.31	-5691.60
G, KJ/KG	-36876.0	-35543.4	-27505.1	-29547.7	-27524.9	-24626.4	-22302.5	-20971.9
S, KJ/(KG) (K)	10.9479	10.9479	10.9479	10.9479	10.9479	10.9479	10.9479	10.9479
M, (1/n)	23.856	24.135	25.551	25.301	25.549	25.727	25.770	25.776
(dLV/dLP)t	-1.02415	-1.02080	-1.00301	-1.00625	-1.00304	-1.00071	-1.00012	-1.00003
(dLV/dLT)p	1.4608	1.4206	1.0916	1.1700	1.0922	1.0253	1.0051	1.0012
Cp, KJ/(KG) (K)	5.1203	4.9690	2.7893	3.4486	2.7952	2.1078	1.8208	1.7311
GAMMAS	1.1378	1.1352	1.1574	1.1418	1.1572	1.1912	1.2179	1.2297
SON VEL,M/SEC	1158.9	1120.0	904.7	953.4	905.1	841.7	788.7	755.3
MACH NUMBER	0.000	1.000	3.093	2.664	3.089	3.633	4.078	4.362

PERFORMANCE PARAMETERS

Ae/At	1.0000	10.066	5.0000	10.000	25.000	50.000	75.000
CSTAR, M/SEC	1708.6	1708.6	1708.6	1708.6	1708.6	1708.6	1708.6
CF	0.6555	1.6375	1.4868	1.6362	1.7899	1.8823	1.9283
Ivac, M/SEC	2106.6	3050.5	2853.6	3048.9	3252.8	3374.8	3435.5
Isp, M/SEC	1120.0	2797.8	2540.3	2795.6	3058.3	3216.0	3294.7

MASS FRACTIONS

*CO	0.07696	0.06751	0.01018	0.02136	0.01026	0.00214	0.00028	0.00005
*CO2	0.15200	0.16686	0.25693	0.23936	0.25680	0.26956	0.27249	0.27285
*H	0.00044	0.00034	0.00001	0.00005	0.00001	0.00000	0.00000	0.00000
HNO	0.00002	0.00001	0.00000	0.00000	0.00000	0.00000	0.00000	0.00000
HNO2	0.00001	0.00000	0.00000	0.00000	0.00000	0.00000	0.00000	0.00000
HO2	0.00014	0.00009	0.00000	0.00000	0.00000	0.00000	0.00000	0.00000
*H2	0.00314	0.00268	0.00044	0.00085	0.00045	0.00012	0.00002	0.00000
H2O	0.28566	0.29378	0.32967	0.32385	0.32962	0.33382	0.33493	0.33511
H2O2	0.00002	0.00001	0.00000	0.00000	0.00000	0.00000	0.00000	0.00000
*N	0.00001	0.00000	0.00000	0.00000	0.00000	0.00000	0.00000	0.00000
*NO	0.02214	0.01774	0.00163	0.00373	0.00164	0.00036	0.00009	0.00004
NO2	0.00005	0.00003	0.00000	0.00000	0.00000	0.00000	0.00000	0.00000
*N2	0.38082	0.38289	0.39043	0.38945	0.39043	0.39103	0.39115	0.39118
N2O	0.00001	0.00001	0.00000	0.00000	0.00000	0.00000	0.00000	0.00000
*O	0.00515	0.00387	0.00011	0.00042	0.00011	0.00001	0.00000	0.00000
*OH	0.03288	0.02709	0.00267	0.00621	0.00269	0.00052	0.00009	0.00003
*O2	0.04055	0.03708	0.00792	0.01471	0.00798	0.00243	0.00095	0.00075

* THERMODYNAMIC PROPERTIES FITTED TO 20000.K

PRODUCTS WHICH WERE CONSIDERED BUT WHOSE MASS FRACTIONS
WERE LESS THAN 5.000000E-06 FOR ALL ASSIGNED CONDITIONS

CH4 C(gr)	HCO H2O(L)	*NH	NH2	NH3
--------------	---------------	-----	-----	-----

NOTE. WEIGHT FRACTION OF FUEL IN TOTAL FUELS AND OF OXIDANT IN TOTAL OXIDANTS

3	3	1337.947	-31.974	-16.184	-14.826	-18.919
3	2	1340.166	-31.918	-16.166	-14.824	-18.918
4	3	1212.262	-35.486	-17.337	-14.938	-19.025
4	2	1210.175	-35.551	-17.358	-14.940	-19.027
5	3	1121.722	-38.528	-18.328	-15.025	-19.105
5	2	1123.659	-38.458	-18.305	-15.023	-19.103

THEORETICAL ROCKET PERFORMANCE ASSUMING EQUILIBRIUM
COMPOSITION DURING EXPANSION FROM INFINITE AREA COMBUSTOR

Pinj = 1000.0 PSIA

CASE = 12

	REACTANT	WT FRACTION (SEE NOTE)	ENERGY KJ/KG-MOL	TEMP K
FUEL	CH6N2 (L)	1.0000000	54200.000	298.150
OXIDANT	N2O4 (L)	1.0000000	-17549.000	298.150

REACTANT DENSITY= 1210.57 KG/CU M

O/F= 2.50000 %FUEL= 28.571429 R,EQ.RATIO= 0.998555 PHI,EQ.RATIO= 0.998555

	CHAMBER	THROAT	EXIT	EXIT	EXIT
Pinf/P	1.0000	1.7318	1322.19	2238.43	3253.04
P, BAR	68.947	39.813	0.05215	0.03080	0.02119
T, K	3386.57	3207.55	1340.17	1210.17	1123.66
RHO, KG/CU M	5.8414 0	3.6029 0	1.2063-2	7.8911-3	5.8480-3
H, KJ/KG	199.89	-427.33	-5395.00	-5611.41	-5752.06
U, KJ/KG	-980.43	-1532.34	-5827.27	-6001.74	-6114.49
G, KJ/KG	-36876.0	-35543.4	-20067.0	-18860.3	-18053.8
S, KJ/(KG) (K)	10.9479	10.9479	10.9479	10.9479	10.9479
M, (1/n)	23.856	24.135	25.778	25.778	25.778
(dLV/dLP)t	-1.02415	-1.02080	-1.00001	-1.00000	-1.00000
(dLV/dLT)p	1.4608	1.4206	1.0004	1.0001	1.0000
Cp, KJ/(KG) (K)	5.1203	4.9690	1.6891	1.6415	1.6099
GAMMAS	1.1378	1.1352	1.2362	1.2446	1.2506
SON VEL, M/SEC	1158.9	1120.0	731.0	697.0	673.2
MACH NUMBER	0.000	1.000	4.576	4.891	5.125

PERFORMANCE PARAMETERS

Ae/At		1.0000	100.00	150.00	200.00
CSTAR, M/SEC		1708.6	1708.6	1708.6	1708.6
CF		0.6555	1.9578	1.9953	2.0193
Ivac, M/SEC		2106.6	3474.3	3523.7	3555.2
Isp, M/SEC		1120.0	3345.1	3409.2	3450.2

MASS FRACTIONS

*CO	0.07696	0.06751	0.00001	0.00000	0.00000
*CO2	0.15200	0.16686	0.27291	0.27292	0.27292
*H	0.00044	0.00034	0.00000	0.00000	0.00000
HNO	0.00002	0.00001	0.00000	0.00000	0.00000
HNO2	0.00001	0.00000	0.00000	0.00000	0.00000
HO2	0.00014	0.00009	0.00000	0.00000	0.00000
*H2	0.00314	0.00268	0.00000	0.00000	0.00000
H2O	0.28566	0.29378	0.33515	0.33516	0.33516
H2O2	0.00002	0.00001	0.00000	0.00000	0.00000
*N	0.00001	0.00000	0.00000	0.00000	0.00000
*NO	0.02214	0.01774	0.00002	0.00001	0.00000
NO2	0.00005	0.00003	0.00000	0.00000	0.00000
*N2	0.38082	0.38289	0.39118	0.39119	0.39119
N2O	0.00001	0.00001	0.00000	0.00000	0.00000
*O	0.00515	0.00387	0.00000	0.00000	0.00000
*OH	0.03288	0.02709	0.00001	0.00000	0.00000
*O2	0.04055	0.03708	0.00072	0.00071	0.00072

* THERMODYNAMIC PROPERTIES FITTED TO 20000.K

PRODUCTS WHICH WERE CONSIDERED BUT WHOSE MASS FRACTIONS
WERE LESS THAN 5.000000E-06 FOR ALL ASSIGNED CONDITIONS

CH4	HCO	*NH	NH2	NH3
C(gr)	H2O(L)			

NOTE. WEIGHT FRACTION OF FUEL IN TOTAL FUELS AND OF OXIDANT IN TOTAL OXIDANTS

THEORETICAL ROCKET PERFORMANCE ASSUMING FROZEN COMPOSITION
AFTER POINT 2

Pinj = 1000.0 PSIA
CASE = 12

	REACTANT	WT FRACTION (SEE NOTE)	ENERGY KJ/KG-MOL	TEMP K
FUEL	CH6N2 (L)	1.0000000	54200.000	298.150
OXIDANT	N2O4 (L)	1.0000000	-17549.000	298.150

REACTANT DENSITY= 1210.57 KG/CU M

O/F= 2.50000 %FUEL= 28.571429 R,EQ.RATIO= 0.998555 PHI,EQ.RATIO= 0.998555

	CHAMBER	THROAT	EXIT	EXIT	EXIT	EXIT	EXIT	EXIT
Pinf/P	1.0000	1.7318	68.046	33.323	87.244	302.39	768.78	1327.00
P, BAR	68.947	39.813	1.0132	2.0691	0.79028	0.22801	0.08968	0.05196
T, K	3386.57	3207.55	1630.44	1871.65	1552.50	1204.85	985.62	872.37
RHO, KG/CU M	5.8414 0	3.6029 0	1.8039-1	3.2089-1	1.4776-1	5.4932-2	2.6413-2	1.7288-2
H, KJ/KG	199.89	-427.33	-3393.03	-2962.89	-3529.26	-4117.22	-4468.39	-4642.93
U, KJ/KG	-980.43	-1532.34	-3954.71	-3607.68	-4064.10	-4532.30	-4807.94	-4943.46
G, KJ/KG	-36876.0	-35543.4	-21243.0	-23453.6	-20525.9	-17307.9	-15258.9	-14193.6
S, KJ/(KG) (K)	10.9479	10.9479	10.9479	10.9479	10.9479	10.9479	10.9479	10.9479
M, (1/n)	23.856	24.135	24.135	24.135	24.135	24.135	24.135	24.135
Cp, KJ/(KG) (K)	5.1203	4.9690	1.7572	1.8076	1.7386	1.6393	1.5626	1.5194
GAMMA _s	1.1378	1.1352	1.2439	1.2355	1.2471	1.2661	1.2828	1.2932
SON VEL, M/SEC	1158.9	1120.0	835.9	892.5	816.7	724.9	660.0	623.4
MACH NUMBER	0.000	1.000	3.207	2.818	3.344	4.053	4.630	4.992

PERFORMANCE PARAMETERS

Ae/At	1.0000	8.3449	5.0000	10.000	25.000	50.000	75.000
CSTAR, M/SEC	1708.6	1708.6	1708.6	1708.6	1708.6	1708.6	1708.6
CF	0.6555	1.5689	1.4720	1.5984	1.7198	1.7884	1.8215
Ivac, M/SEC	2106.6	2890.2	2771.4	2926.8	3079.7	3166.7	3208.7
Isp, M/SEC	1120.0	2680.6	2515.1	2731.0	2938.4	3055.6	3112.2

MASS FRACTIONS

*CO	0.06751	*CO2	0.16686	*H	0.00034
HNO	0.00001	HO2	0.00009	*H2	0.00268
H2O	0.29378	H2O2	0.00001	*NO	0.01774
NO2	0.00003	*N2	0.38289	N2O	0.00001
*O	0.00387	*OH	0.02709	*O2	0.03708

* THERMODYNAMIC PROPERTIES FITTED TO 20000.K

PRODUCTS WHICH WERE CONSIDERED BUT WHOSE MASS FRACTIONS
WERE LESS THAN 5.000000E-06 FOR ALL ASSIGNED CONDITIONS

CH4	HCO	*NH	NH2	NH3
C(gr)	H2O(L)			

NOTE. WEIGHT FRACTION OF FUEL IN TOTAL FUELS AND OF OXIDANT IN TOTAL OXIDANTS

THEORETICAL ROCKET PERFORMANCE ASSUMING FROZEN COMPOSITION
AFTER POINT 2

Pinj = 1000.0 PSIA
CASE = 12

	REACTANT	WT FRACTION (SEE NOTE)	ENERGY KJ/KG-MOL	TEMP K
FUEL	CH6N2 (L)	1.0000000	54200.000	298.150
OXIDANT	N2O4 (L)	1.0000000	-17549.000	298.150

REACTANT DENSITY= 1210.57 KG/CU M

O/F= 2.50000 %FUEL= 28.571429 R,EQ.RATIO= 0.998555 PHI,EQ.RATIO= 0.998555

	CHAMBER	THROAT	EXIT	EXIT	EXIT
Pinf/P	1.0000	1.7318	1955.79	3382.76	4995.07
P, BAR	68.947	39.813	0.03525	0.02038	0.01380
T, K	3386.57	3207.55	798.24	702.08	639.53
RHO, KG/CU M	5.8414 0	3.6029 0	1.2819-2	8.4269-3	6.2651-3
H, KJ/KG	199.89	-427.33	-4754.49	-4895.92	-4985.94
U, KJ/KG	-980.43	-1532.34	-5029.48	-5137.79	-5206.26
G, KJ/KG	-36876.0	-35543.4	-13493.5	-12582.3	-11987.4
S, KJ/(KG) (K)	10.9479	10.9479	10.9479	10.9479	10.9479
M, (1/n)	23.856	24.135	24.135	24.135	24.135
Cp, KJ/(KG) (K)	5.1203	4.9690	1.4902	1.4516	1.4264
GAMMAS	1.1378	1.1352	1.3007	1.3112	1.3184
SON VEL, M/SEC	1158.9	1120.0	598.1	563.1	539.0
MACH NUMBER	0.000	1.000	5.263	5.669	5.975

PERFORMANCE PARAMETERS

Ae/At	1.0000	100.00	150.00	200.00
CSTAR, M/SEC	1708.6	1708.6	1708.6	1708.6
CF	0.6555	1.8423	1.8685	1.8849
Ivac, M/SEC	2106.6	3235.2	3268.2	3288.9
Isp, M/SEC	1120.0	3147.8	3192.4	3220.5

MASS FRACTIONS

*CO	0.06751	*CO2	0.16686	*H	0.00034
HNO	0.00001	HO2	0.00009	*H2	0.00268
H2O	0.29378	H2O2	0.00001	*NO	0.01774
NO2	0.00003	*N2	0.38289	N2O	0.00001
*O	0.00387	*OH	0.02709	*O2	0.03708

* THERMODYNAMIC PROPERTIES FITTED TO 20000.K

PRODUCTS WHICH WERE CONSIDERED BUT WHOSE MASS FRACTIONS
WERE LESS THAN 5.000000E-06 FOR ALL ASSIGNED CONDITIONS

CH4	HCO	*NH	NH2	NH3
C(gr)	H2O(L)			

NOTE. WEIGHT FRACTION OF FUEL IN TOTAL FUELS AND OF OXIDANT IN TOTAL OXIDANTS

!EXAMPLE 13:

- ! (a) Rocket problem with an infinite-area combustor (rocket). This problem was selected to show some unusual derivatives.
- ! (b) Tripropellant. Fuels are N2H4(L) and Be(L) and oxidant is H2O2(L), all at 298.15 K.
- ! (c) Reactant mixture is given as 67% fuel by weight (%fuel=67.).
- ! (d) Chamber pressure is 3000 psia (p,psia=3000).
- ! (e) Calculations are to be for equilibrium conditions only (equilibrium).
- ! (f) Four exit pressure ratios are assigned (pi/p=3,10,30,300).
- ! (g) BeO(L) is included as possible combustion product for the first point (insert).
- ! (h) Mole fractions > 1.e-10 are to be in e-format (trace=1.e-10).
- ! (i) Units in final tables to be non-SI (calories).

```
react fuel = N2H4(L)    wt%= 80    t=298.15
      fuel = Be(a)      wt%= 20    t=298.15
      oxid = H2O2(L)    wt%=100   t=298.15
prob  rocket case=13  p,psia=3000, pi/p=3,10,30,300,equilibrium  %fuel = 67.
```

```
outp trace= 1.e-10 calories
insert BeO(L)
end
```

```
OPTIONS: TP=F HP=F SP=F TV=F UV=F SV=F DETN=F SHOCK=F REFL=F INCD=F
RKT=T FROZ=F EQL=T IONS=F SIUNIT=F DEBUGF=F SHKDBG=F DETDBG=F TRNSPT=F
```

```
TRACE= 1.00E-10 S/R= 0.000000E+00 H/R= 0.000000E+00 U/R= 0.000000E+00
```

```
Pc, BAR = 206.841913
```

```
Pc/P = 3.0000 10.0000 30.0000 300.0000
```

```
SUBSONIC AREA RATIOS =
```

```
SUPERSONIC AREA RATIOS =
```

```
NFZ= 1 Mdot/Ac= 0.000000E+00 Ac/At= 0.000000E+00
```

REACTANT	WT.FRAC	(ENERGY/R), K	TEMP, K	DENSITY
EXPLODED FORMULA				
F: N2H4(L)	0.800000	0.605929E+04	298.15	0.8740
N 2.00000	H 4.00000			
F: Be(a)	0.200000	-0.130953E-05	298.15	1.4310
BE 1.00000				
O: H2O2(L)	1.000000	-0.225846E+05	298.15	0.0000
H 2.00000	O 2.00000			

SPECIES BEING CONSIDERED IN THIS SYSTEM
(CONDENSED PHASE MAY HAVE NAME LISTED SEVERAL TIMES)

l 6/94 *Be	tpis81 BeH	j12/60 BeH2
j 6/63 BeN	j12/74 *BEO	j12/75 BeOH
j12/75 BeO2H2	j 9/63 Be2O	j 9/63 Be2O2
j 9/63 Be3O3	j 9/63 Be4O4	j 9/63 Be5O5
j 9/63 Be6O6	l 6/94 *H	l12/89 HNO
tpis89 HNO2	l 4/90 HNO3	l 5/89 HO2
tpis78 *H2	l 8/89 H2O	l 2/93 H2O2
l 6/88 *N	l11/89 *NH	l12/89 NH2
tpis89 NH3	tpis89 NH2OH	tpis89 *NO
l 7/88 NO2	j12/64 NO3	tpis78 *N2
l 5/90 N2H2	tpis89 NH2NO2	l 5/90 N2H4
l 7/88 N2O	l 4/90 N2O3	tpis89 N2O4
l 4/90 N2O5	tpis89 N3	l 7/88 N3H
l 1/90 *O	tpis78 *OH	tpis89 *O2
l 5/90 O3	srd 93 Be(a)	srd 93 Be(a)
srd 93 Be(b)	srd 93 Be(L)	coda89 BeO(a)
coda89 BeO(a)	coda89 BeO(b)	coda89 BeO(L)
J12/75 BeO2H2(b)	l 8/89 H2O(s)	l 8/89 H2O(L)
BeO(L)	INSERTED	

O/F = 0.492537

	EFFECTIVE FUEL	EFFECTIVE OXIDANT	MIXTURE
ENTHALPY	h(2)/R	h(1)/R	h0/R
(KG-MOL) (K) /KG	0.15126831E+03	-0.66396668E+03	-0.11775924E+03
KG-FORM.WT./KG	bi(2)	bi(1)	boi
*N	0.49929412E-01	0.00000000E+00	0.33452706E-01
*H	0.99858825E-01	0.58798142E-01	0.86308799E-01
*Be	0.22192184E-01	0.00000000E+00	0.14868763E-01
*O	0.00000000E+00	0.58798142E-01	0.19403387E-01

POINT	ITN	T	N	H	BE	O
1	13	3015.477	-12.175	-7.991	-13.104	-20.398
Pinf/Pt = 1.743807						
2	4	2802.203	-12.317	-8.137	-13.670	-21.009
ADD BeO(b)						
2	4	2851.000	-12.349	-8.168	-13.530	-20.860
Pinf/Pt = 1.630416						
2	4	2851.000	-12.315	-8.135	-13.530	-20.860
Pinf/Pt = 1.626685						
2	2	2851.000	-12.314	-8.133	-13.530	-20.860
3	5	2604.969	-12.455	-8.281	-14.318	-21.678
PHASE CHANGE, REPLACE BeO(L) WITH BeO(b)						
3	4	2922.003	-12.667	-8.486	-13.245	-20.656
ADD BeO(L)						
3	4	2851.000	-12.621	-8.441	-13.530	-20.859
4	5	2204.200	-12.760	-8.601	-16.149	-23.464
PHASE CHANGE, REPLACE BeO(L) WITH BeO(a)						
4	4	2451.195	-12.948	-8.779	-15.487	-22.276
PHASE CHANGE, REPLACE BeO(a) WITH BeO(b)						
4	2	2451.586	-12.948	-8.779	-15.484	-22.274
5	5	2061.574	-13.195	-9.042	-18.232	-24.282
PHASE CHANGE, REPLACE BeO(b) WITH BeO(a)						
5	2	2067.118	-13.199	-9.046	-18.191	-24.247
6	5	1396.587	-13.721	-9.603	-27.072	-30.583

THEORETICAL ROCKET PERFORMANCE ASSUMING EQUILIBRIUM

COMPOSITION DURING EXPANSION FROM INFINITE AREA COMBUSTOR

Pinj = 3000.0 PSIA
CASE = 13

	REACTANT	WT FRACTION (SEE NOTE)	ENERGY CAL/MOL	TEMP K
FUEL	N2H4 (L)	0.8000000	12041.109	298.150
FUEL	Be (a)	0.2000000	0.000	298.150
OXIDANT	H2O2 (L)	1.0000000	-44880.497	298.150

O/F= 0.49254 %FUEL= 67.000000 R,EQ.RATIO= 2.990363 PHI,EQ.RATIO= 4.980725

	CHAMBER	THROAT	EXIT	EXIT	EXIT	EXIT
Pinf/P	1.0000	1.6267	3.0000	10.000	30.000	300.00
P, ATM	204.14	125.49	68.046	20.414	6.8046	0.68046
T, K	3015.48	2851.00	2851.00	2451.59	2067.12	1396.59
RHO, G/CC	1.3715-2	8.9279-3	4.8341-3	1.6916-3	6.6969-4	9.9159-5
H, CAL/G	-234.01	-403.86	-612.35	-997.47	-1292.67	-1762.88
U, CAL/G	-594.46	-744.26	-953.24	-1289.71	-1538.74	-1929.07
G, CAL/G	-10112.8	-9743.85	-9952.34	-9028.96	-8064.63	-6338.16
S, CAL/(G) (K)	3.2760	3.2760	3.2760	3.2760	3.2760	3.2760
M, (1/n)	16.625	16.644	16.620	16.670	16.694	16.700
MW, MOL WT	13.372	13.376	13.361	13.370	13.376	13.378
(dLV/dLP)t	-1.00283	-1.00209	-1.00262	-1.00098	-1.00023	-1.00002
(dLV/dLT)p	1.0465	0.0000	0.0000	1.0209	1.0053	1.0001
Cp, CAL/(G) (K)	0.9575	0.0000	0.0000	0.7984	0.7448	0.6649
GAMMAS	1.1546	0.9979	0.9974	1.1829	1.1923	1.2180
SON VEL, M/SEC	1319.6	1192.2	1192.7	1202.7	1108.0	920.3
MACH NUMBER	0.000	1.000	1.492	2.102	2.686	3.887

PERFORMANCE PARAMETERS

Ae/At	1.0000	1.2374	2.4894	5.3398	30.010
CSTAR, FT/SEC	6375.8	6375.8	6375.8	6375.8	6375.8
CF	0.6135	0.9156	1.3006	1.5316	1.8405
Ivac, LB-SEC/LB	243.4	263.2	307.1	338.8	384.6
Isp, LB-SEC/LB	121.6	181.4	257.7	303.5	364.7

MOLE FRACTIONS

*Be	8.681	-6	3.857	-6	7.111	-6	2.586	-7	1.859	-9	1.351	-16
BeH	1.104	-6	3.684	-7	4.994	-7	8.737	-9	3.040	-11	4.032	-19
BeH2	1.171	-5	5.070	-6	5.054	-6	2.194	-7	3.305	-9	7.002	-15
BeN	4.457	-8	1.236	-8	1.677	-8	1.685	-10	2.807	-13	3.873	-22
*BEO	3.551	-7	1.342	-7	2.476	-7	5.763	-9	2.341	-11	3.240	-19
BeOH	1.240	-4	6.727	-5	9.125	-5	6.858	-6	1.620	-7	7.729	-13
BeO2H2	2.9966	-3	2.5056	-3	2.5000	-3	7.9244	-4	1.6333	-4	1.1620	-6
Be2O	7.060	-7	2.511	-7	4.630	-7	4.580	-9	5.497	-12	1.278	-21
Be2O2	3.894	-7	1.728	-7	3.188	-7	6.143	-9	1.750	-11	5.868	-20
Be3O3	7.665	-7	4.787	-7	8.831	-7	2.536	-8	1.184	-10	1.538	-18
Be4O4	2.173	-7	1.434	-7	2.646	-7	4.831	-9	1.201	-11	2.030	-20
Be5O5	6.079	-9	4.184	-9	7.718	-9	8.580	-11	1.070	-13	1.914	-23
Be6O6	3.717	-10	2.827	-10	5.216	-10	4.205	-12	3.317	-15	1.280	-25
*H	7.4008	-3	5.5693	-3	7.5542	-3	2.8642	-3	6.2153	-4	3.5990	-6
HNO	9.938	-8	4.355	-8	4.349	-8	3.791	-9	1.498	-10	8.418	-15
HNO2	2.406	-10	9.046	-11	9.038	-11	4.939	-12	1.004	-13	7.126	-19
HO2	2.553	-9	1.015	-9	1.379	-9	7.839	-11	1.296	-12	2.695	-18
*H2	5.1230	-1	5.1354	-1	5.1214	-1	5.1486	-1	5.1624	-1	5.1664	-1
H2O	5.7363	-2	5.7964	-2	5.7835	-2	5.9767	-2	6.0485	-2	6.0664	-2
H2O2	5.504	-9	2.426	-9	2.422	-9	2.117	-10	7.944	-12	3.489	-16
*N	4.529	-7	1.904	-7	2.585	-7	1.721	-8	3.711	-10	1.810	-15
*NH	2.470	-6	1.086	-6	1.084	-6	9.309	-8	3.580	-9	1.671	-13
NH2	1.921	-5	9.841	-6	7.222	-6	1.113	-6	1.197	-7	2.226	-10
NH3	3.0252	-4	2.1058	-4	1.1363	-4	4.9681	-5	2.7432	-5	1.3148	-5
NH2OH	2.905	-9	1.107	-9	5.975	-10	4.397	-11	2.287	-12	9.065	-16
*NO	1.860	-5	1.087	-5	1.476	-5	2.620	-6	2.002	-7	4.479	-11
NO2	1.236	-10	4.605	-11	6.258	-11	2.930	-12	3.760	-14	3.713	-20
*N2	2.2349	-1	2.2362	-1	2.2342	-1	2.2360	-1	2.2372	-1	2.2376	-1
N2H2	7.477	-9	2.733	-9	1.476	-9	9.647	-11	4.461	-12	1.288	-15
N2O	9.032	-9	4.103	-9	4.101	-9	3.946	-10	1.757	-11	1.410	-15
N3H	1.480	-10	4.527	-11	2.447	-11	9.231	-13	2.001	-14	5.124	-19
*O	2.448	-6	1.245	-6	2.297	-6	2.389	-7	7.057	-9	5.241	-14
*OH	2.7768	-4	1.8428	-4	2.5007	-4	6.4898	-5	8.1758	-6	8.2744	-9
*O2	1.083	-7	5.610	-8	1.036	-7	1.142	-8	3.535	-10	2.936	-15
BeO (a)	0.0000	0	0.0000	0	0.0000	0	0.0000	0	1.9873	-1	1.9892	-1
BeO (b)	0.0000	0	1.3853	-2	1.5511	-1	1.9799	-1	0.0000	0	0.0000	0
BeO (L)	1.9567	-1	1.8245	-1	4.0950	-2	0.0000	0	0.0000	0	0.0000	0

* THERMODYNAMIC PROPERTIES FITTED TO 20000.K

PRODUCTS WHICH WERE CONSIDERED BUT WHOSE MOLE FRACTIONS
WERE LESS THAN 1.000000E-10 FOR ALL ASSIGNED CONDITIONS

HNO3	NO3	NH2NO2	N2H4	N2O3
N2O4	N2O5	N3	O3	Be (a)
Be (b)	Be (L)	BeO2H2 (b)	H2O (s)	H2O (L)

NOTE. WEIGHT FRACTION OF FUEL IN TOTAL FUELS AND OF OXIDANT IN TOTAL OXIDANTS

```

! EXAMPLE 14:
! (a) Output from this case is used 1) to illustrate the effect of
! condensed species on volume and molecular weight (see sec.2.2,part I)
! (b) Assigned-temperature-and-pressure problem (tp) .
! (c) Reactants are H2(L) and O2(L) and amounts are specified in moles.
! (d) The "exploded" formulas are given to save the program looking them
! up. Reactant enthalpies are not needed for assigned temperature
! problems.
! (e) Assigned pressure in atmospheres is p,atm = .05.
! (f) Assigned temperatures in kelvin are t,k =1000,500,351,305,304.3,
! 304, 300.
! (g) Print intermediate output for the fifth point with debug = 5.

```

```

      reac      name H2(L) moles=100   H 2
              name O2(L) moles=60    O 2

```

```

      prob      tp p,atm=.05 case=14
              t,k = 1000,500,350,305,304.3,304.2,304,300,

```

```

      output    siunits debug = 5

```

```

      end

```

```

OPTIONS: TP=T HP=F SP=F TV=F UV=F SV=F DETN=F SHOCK=F REFL=F INCD=F
RKT=F FROZ=F EQL=F IONS=F SIUNIT=T DEBUGF=F SHKDBG=F DETDBG=F TRNSPT=F

```

```

T,K = 1000.0000 500.0000 350.0000 305.0000 304.3000 304.2000 304.0000 30

```

```

TRACE= 0.00E+00 S/R= 0.000000E+00 H/R= 0.000000E+00 U/R= 0.000000E+00

```

```

P,BAR = 0.050663

```

REACTANT	MOLES	(ENERGY/R),K	TEMP,K	DENSITY
EXPLODED FORMULA				
N: H2(L)	100.000000	0.000000E+00	0.00	0.8740
H	2.00000			
N: O2(L)	60.000000	-0.156101E+04	90.17	1.4310
O	2.00000			

```

SPECIES BEING CONSIDERED IN THIS SYSTEM
(CONDENSED PHASE MAY HAVE NAME LISTED SEVERAL TIMES)

```

1 6/94 *H	1 5/89 HO2	tpis78 *H2
1 8/89 H2O	1 2/93 H2O2	1 1/90 *O
tpis78 *OH	tpis89 *O2	1 5/90 O3
1 8/89 H2O(s)	1 8/89 H2O(L)	

O/F = 0.000000

	EFFECTIVE FUEL	EFFECTIVE OXIDANT	MIXTURE
ENTHALPY (KG-MOL) (K) /KG	h(2)/R -0.44147845E+02	h(1)/R 0.00000000E+00	h0/R -0.44147845E+02
KG-FORM.WT./KG	bi(2)	bi(1)	b0i
*H	0.94272209E-01	0.00000000E+00	0.94272209E-01
*O	0.56563325E-01	0.00000000E+00	0.56563325E-01

POINT	ITN	T	H	O
1	10	1000.000	-20.527	-15.973
2	3	500.000	-34.596	-15.230
3	1	350.000	-46.944	-15.049
4	1	305.000	-53.061	-15.028

ITERATION	1	MATRIX		
	0.188544E+00	0.942722E-01	0.942722E-01	-0.114417E+02
	0.942722E-01	0.659905E-01	0.565633E-01	-0.600419E+01
	0.942722E-01	0.565633E-01	0.000000E+00	-0.586253E+01

SOLUTION VECTOR		H	O
		-0.531707E+02	-0.150274E+02
			0.000000E+00

T= 0.30430000E+03 ENN= 0.51849715E-01 ENNL=-0.29594058E+01 PP= 0.50662500E-01
LN P/N=-0.23163446E-01 AMBDA= 0.10000000E+01

	Nj	LN Nj	DEL LN Nj	H0j/RT
		S0j/R	G0j/RT	Gj/RT
*H	0.000000E+00	-0.125204E+03	-0.307497E+00	0.862123E+02
		0.138484E+02	0.723640E+02	-0.528633E+02
HO2	0.000000E+00	-0.604867E+02	-0.121044E+00	0.504603E+01
		0.276408E+02	-0.225947E+02	-0.831046E+02
*H2	0.000000E+00	-0.903810E+02	-0.219421E+00	0.701441E-01
		0.157881E+02	-0.157179E+02	-0.106122E+03
H2O	0.471361E-01	-0.305472E+01	0.177636E-14	-0.954977E+02
		0.227933E+02	-0.118291E+03	-0.121369E+03
H2O2	0.000000E+00	-0.541943E+02	-0.956804E-01	-0.537719E+02
		0.283113E+02	-0.820832E+02	-0.136301E+03
*O	0.000000E+00	-0.938907E+02	-0.226071E+00	0.985373E+02
		0.194248E+02	0.791125E+02	-0.148014E+02
*OH	0.000000E+00	-0.614818E+02	-0.145407E+00	0.156242E+02
		0.221720E+02	-0.654785E+01	-0.680528E+02
*O2	0.471361E-02	-0.535730E+01	-0.639488E-13	0.714483E-01
		0.247458E+02	-0.246744E+02	-0.300549E+02
O3	0.000000E+00	-0.722284E+02	-0.128601E+00	0.561412E+02
		0.288433E+02	0.272979E+02	-0.449537E+02
H2O(s)	0.000000E+00	0.000000E+00	0.000000E+00	-0.115317E+03
		0.550772E+01	-0.120825E+03	-0.172966E+03
H2O(L)	0.000000E+00	0.000000E+00	0.000000E+00	-0.112509E+03
		0.861762E+01	-0.121126E+03	-0.230622E+03
5	1	304.300	-53.171	-15.027

H2O (s) 200.000 273.150 0.0000000E+00

H2O (L) 273.150 600.000 0.0000000E+00

[G0j-SUM(Aij*PIi)]/Mj = -0.9021700E-03 MAX NEG DELTA G = -0.9021700E-03

ADD H2O (L)

ITERATION 0 MATRIX

0.188544E+00	0.942722E-01	0.200000E+01	0.942722E-01	-0.114417E+02
0.942722E-01	0.659905E-01	0.100000E+01	0.565633E-01	-0.600419E+01
0.200000E+01	0.100000E+01	0.000000E+00	0.000000E+00	-0.121385E+03
0.942722E-01	0.565633E-01	0.000000E+00	0.770217E-15	-0.586253E+01

SOLUTION VECTOR

H	O		
-0.532195E+02	-0.149462E+02	0.842705E-02	-0.162528E+00

T= 0.30430000E+03 ENN= 0.51849715E-01 ENNL=-0.29594058E+01 PP= 0.50662500E-01

LN P/N=-0.23163446E-01 AMBDA= 0.10000000E+01

	Nj	LN Nj	DEL LN Nj	H0j/RT
		S0j/R	G0j/RT	Gj/RT
*H	0.000000E+00	-0.125512E+03	-0.211287E+00	0.862123E+02
		0.138484E+02	0.723640E+02	-0.531707E+02
HO2	0.000000E+00	-0.606077E+02	-0.487585E-01	0.504603E+01
		0.276408E+02	-0.225947E+02	-0.832256E+02
*H2	0.000000E+00	-0.906004E+02	-0.260046E+00	0.701441E-01
		0.157881E+02	-0.157179E+02	-0.106341E+03
H2O	0.471361E-01	-0.305472E+01	-0.178781E+00	-0.954977E+02
		0.227933E+02	-0.118291E+03	-0.121369E+03
H2O2	0.000000E+00	-0.542900E+02	-0.975171E-01	-0.537719E+02
		0.283113E+02	-0.820832E+02	-0.136396E+03
*O	0.000000E+00	-0.941168E+02	-0.812642E-01	0.985373E+02
		0.194248E+02	0.791125E+02	-0.150274E+02
*OH	0.000000E+00	-0.616272E+02	-0.130023E+00	0.156242E+02
		0.221720E+02	-0.654785E+01	-0.681982E+02
*O2	0.471361E-02	-0.535730E+01	0.124345E-12	0.714483E-01
		0.247458E+02	-0.246744E+02	-0.300549E+02
O3	0.000000E+00	-0.723570E+02	0.812642E-01	0.561412E+02
		0.288433E+02	0.272979E+02	-0.450823E+02
H2O (s)	0.000000E+00	0.000000E+00	0.000000E+00	-0.115594E+03
		0.549580E+01	-0.121090E+03	-0.172966E+03
H2O (L)	0.000000E+00	0.000000E+00	0.842705E-02	-0.112788E+03
		0.859679E+01	-0.121385E+03	-0.121385E+03

ITERATION 1 MATRIX

0.157678E+00	0.788388E-01	0.200000E+01	0.788388E-01	-0.957128E+01
0.788388E-01	0.582738E-01	0.100000E+01	0.488466E-01	-0.506744E+01
0.200000E+01	0.100000E+01	0.000000E+00	0.000000E+00	-0.121385E+03
0.788388E-01	0.488466E-01	0.000000E+00	0.611676E-04	-0.492589E+01

SOLUTION VECTOR

H	O		
-0.532162E+02	-0.149527E+02	-0.122861E-02	0.131474E-01

T= 0.30430000E+03 ENN= 0.44071839E-01 ENNL=-0.31219343E+01 PP= 0.50662500E-01
LN P/N= 0.13936499E+00 AMBDA= 0.10000000E+01

	Nj	LN Nj SOj/R	DEL LN Nj GOj/RT	HOj/RT Gj/RT
*H	0.000000E+00	-0.125723E+03 0.138484E+02	0.164343E-01 0.723640E+02	0.862123E+02 -0.532195E+02
HO2	0.000000E+00	-0.606565E+02 0.276408E+02	0.328686E-02 -0.225947E+02	0.504603E+01 -0.831118E+02
*H2	0.000000E+00	-0.908604E+02 0.157881E+02	0.197211E-01 -0.157179E+02	0.701441E-01 -0.106439E+03
H2O	0.394194E-01	-0.323350E+01 0.227933E+02	0.131474E-01 -0.118291E+03	-0.954977E+02 -0.121385E+03
H2O2	0.000000E+00	-0.543875E+02 0.283113E+02	0.657371E-02 -0.820832E+02	-0.537719E+02 -0.136331E+03
*O	0.000000E+00	-0.941980E+02 0.194248E+02	0.657371E-02 0.791125E+02	0.985373E+02 -0.149462E+02
*OH	0.000000E+00	-0.617572E+02 0.221720E+02	0.986057E-02 -0.654785E+01	0.156242E+02 -0.681657E+02
*O2	0.471361E-02	-0.535730E+01 0.247458E+02	-0.127898E-12 -0.246744E+02	0.714483E-01 -0.298923E+02
O3	0.000000E+00	-0.722758E+02 0.288433E+02	-0.657371E-02 0.272979E+02	0.561412E+02 -0.448385E+02
H2O(s)	0.000000E+00	0.000000E+00 0.549580E+01	0.000000E+00 -0.121090E+03	-0.115594E+03 -0.172966E+03
H2O(L)	0.842705E-02	0.000000E+00 0.859679E+01	-0.122861E-02 -0.121385E+03	-0.112788E+03 -0.121385E+03

ITERATION 2 MATRIX

0.159764E+00	0.798822E-01	0.200000E+01	0.798822E-01	-0.969652E+01
0.798822E-01	0.587955E-01	0.100000E+01	0.493683E-01	-0.513018E+01
0.200000E+01	0.100000E+01	0.000000E+00	0.000000E+00	-0.121385E+03
0.798822E-01	0.493683E-01	0.000000E+00	-0.403867E-06	-0.498922E+01

SOLUTION VECTOR

H	O		
-0.532162E+02	-0.149527E+02	0.126035E-13	-0.856736E-04

T= 0.30430000E+03 ENN= 0.44655096E-01 ENNL=-0.31087869E+01 PP= 0.50662500E-01
 LN P/N= 0.12621757E+00 AMBDA= 0.10000000E+01

	Nj	LN Nj	DEL LN Nj	H0j/RT
		SOj/R	GOj/RT	Gj/RT
*H	0.000000E+00	-0.125706E+03 0.138484E+02	-0.107092E-03 0.723640E+02	0.862123E+02 -0.532162E+02
HO2	0.000000E+00	-0.606532E+02 0.276408E+02	-0.214184E-04 -0.225947E+02	0.504603E+01 -0.831217E+02
*H2	0.000000E+00	-0.908407E+02 0.157881E+02	-0.128510E-03 -0.157179E+02	0.701441E-01 -0.106432E+03
H2O	0.399411E-01	-0.322035E+01 0.227933E+02	-0.856736E-04 -0.118291E+03	-0.954977E+02 -0.121385E+03
H2O2	0.000000E+00	-0.543809E+02 0.283113E+02	-0.428368E-04 -0.820832E+02	-0.537719E+02 -0.136338E+03
*O	0.000000E+00	-0.941915E+02 0.194248E+02	-0.428368E-04 0.791125E+02	0.985373E+02 -0.149527E+02
*OH	0.000000E+00	-0.617473E+02 0.221720E+02	-0.642552E-04 -0.654785E+01	0.156242E+02 -0.681690E+02
*O2	0.471361E-02	-0.535730E+01 0.247458E+02	-0.284217E-13 -0.246744E+02	0.714483E-01 -0.299055E+02
O3	0.000000E+00	-0.722823E+02 0.288433E+02	0.428368E-04 0.272979E+02	0.561412E+02 -0.448582E+02
H2O(s)	0.000000E+00	0.000000E+00 0.549580E+01	0.000000E+00 -0.121090E+03	-0.115594E+03 -0.172966E+03
H2O(L)	0.719845E-02	0.000000E+00 0.859679E+01	0.126035E-13 -0.121385E+03	-0.112788E+03 -0.121385E+03

ITERATION 3 MATRIX

0.159751E+00	0.798753E-01	0.200000E+01	0.798753E-01	-0.969568E+01
0.798753E-01	0.587921E-01	0.100000E+01	0.493649E-01	-0.512976E+01
0.200000E+01	0.100000E+01	0.000000E+00	0.000000E+00	-0.121385E+03
0.798753E-01	0.493649E-01	0.000000E+00	-0.172989E-10	-0.498880E+01

SOLUTION VECTOR

H	O		
-0.532162E+02	-0.149527E+02	-0.757420E-14	-0.367002E-08

T= 0.30430000E+03 ENN= 0.44651270E-01 ENNL=-0.31088725E+01 PP= 0.50662500E-01
 LN P/N= 0.12630324E+00 AMBDA= 0.10000000E+01

	Nj	LN Nj	DEL LN Nj	H0j/RT
		SOj/R	GOj/RT	Gj/RT
*H	0.000000E+00	-0.125707E+03	-0.458755E-08	0.862123E+02
		0.138484E+02	0.723640E+02	-0.532162E+02
HO2	0.000000E+00	-0.606532E+02	-0.917481E-09	0.504603E+01
		0.276408E+02	-0.225947E+02	-0.831216E+02
*H2	0.000000E+00	-0.908408E+02	-0.550507E-08	0.701441E-01
		0.157881E+02	-0.157179E+02	-0.106432E+03
H2O	0.399377E-01	-0.322044E+01	-0.367004E-08	-0.954977E+02
		0.227933E+02	-0.118291E+03	-0.121385E+03
H2O2	0.000000E+00	-0.543810E+02	-0.183496E-08	-0.537719E+02
		0.283113E+02	-0.820832E+02	-0.136338E+03
*O	0.000000E+00	-0.941915E+02	-0.183497E-08	0.985373E+02
		0.194248E+02	0.791125E+02	-0.149527E+02
*OH	0.000000E+00	-0.617474E+02	-0.275250E-08	0.156242E+02
		0.221720E+02	-0.654785E+01	-0.681689E+02
*O2	0.471361E-02	-0.535730E+01	0.746070E-13	0.714483E-01
		0.247458E+02	-0.246744E+02	-0.299054E+02
O3	0.000000E+00	-0.722823E+02	0.183512E-08	0.561412E+02
		0.288433E+02	0.272979E+02	-0.448581E+02
H2O(s)	0.000000E+00	0.000000E+00	0.000000E+00	-0.115594E+03
		0.549580E+01	-0.121090E+03	-0.172966E+03
H2O(L)	0.719845E-02	0.000000E+00	-0.757420E-14	-0.112788E+03
		0.859679E+01	-0.121385E+03	-0.121385E+03
5	3	304.300	-53.216	-14.953

H2O(s) 200.000 273.150 0.000000E+00

H2O(L) 273.150 600.000 0.7198445E-02

T DERIV MATRIX

0.159751E+00	0.798753E-01	0.200000E+01	0.798753E-01	-0.762791E+01
0.798753E-01	0.587921E-01	0.100000E+01	0.493649E-01	-0.381328E+01
0.200000E+01	0.100000E+01	0.000000E+00	0.000000E+00	-0.112788E+03
0.798753E-01	0.493649E-01	0.000000E+00	0.000000E+00	-0.381362E+01

SOLUTION VECTOR

H	O
-0.930373E+02	0.732862E+02

P DERIV MATRIX

0.159751E+00	0.798753E-01	0.200000E+01	0.798753E-01	0.798753E-01
0.798753E-01	0.587921E-01	0.100000E+01	0.493649E-01	0.493649E-01
0.200000E+01	0.100000E+01	0.000000E+00	0.000000E+00	0.000000E+00
0.798753E-01	0.493649E-01	0.000000E+00	0.000000E+00	0.446513E-01

SOLUTION VECTOR

H	O
-0.236821E+01	0.473642E+01

POINT= 5 P= 0.506625E-01 T= 0.304300E+03

H/R=-0.140755E+04 S/R= 0.123707E+01

M= 0.223958E+02 CP/R= 0.113349E+03 DLVPT=-0.947284E+01

DLVTP= 0.147501E+03 GAMMA(S)= 0.110818E+01 V= 0.222990E+07

6	3	304.200	-53.247	-14.929
7	4	304.000	-53.305	-14.886
8	6	300.000	-54.288	-14.426

THERMODYNAMIC EQUILIBRIUM PROPERTIES AT ASSIGNED
TEMPERATURE AND PRESSURE

CASE = 14

REACTANT	MOLES	ENERGY KJ/KG-MOL	TEMP K
NAME H2 (L)	100.0000000	0.000	0.000
NAME O2 (L)	60.0000000	-12979.000	90.170

REACTANT DENSITY= 1349.29 KG/CU M

O/F= 0.00000 %FUEL= 0.000000 R,EQ.RATIO= 0.833333 PHI,EQ.RATIO= 0.000000

THERMODYNAMIC PROPERTIES

P, BAR	0.05066	0.05066	0.05066	0.05066	0.05066	0.05066	0.05066	0.05066	0.05066
T, K	1000.00	500.00	350.00	305.00	304.30	304.20	304.00	300.00	
RHO, KG/CU M	1.1752-2	2.3504-2	3.3577-2	3.8530-2	4.4845-2	4.7014-2	5.1325-2	1.3024-1	
H, KJ/KG	-10066.0	-11043.6	-11309.1	-11386.9	-11703.1	-11792.8	-11948.7	-12988.1	
U, KJ/KG	-10497.1	-11259.2	-11460.0	-11518.4	-11816.0	-11900.5	-12047.4	-13027.0	
G, KJ/KG	-23601.6	-17139.8	-15355.8	-14840.7	-14833.0	-14831.9	-14830.0	-14801.2	
S, KJ/(KG) (K)	13.5356	12.1924	11.5619	11.3239	10.2856	9.9907	9.4781	6.0435	
M, (1/n)	19.287	19.287	19.287	19.287	22.396	23.471	25.607	64.125	
MW, MOL WT	19.287	19.287	19.287	19.287	19.287	19.287	19.287	19.287	
(dLV/dLP)t	-1.00000	-1.00000	-1.00000	-1.00000	-9.47284	-9.03875	-8.28504	-3.30842	
(dLV/dLT)p	1.0000	1.0000	1.0000	1.0000	147.5009	140.0542	127.1235	41.6525	
Cp, KJ/(KG) (K)	2.1108	1.8069	1.7370	1.7233	942.4445	854.1858	711.2554	96.0625	
GAMMAS	1.2567	1.3133	1.3301	1.3336	1.1082	1.1061	1.1019	1.0345	
SON VEL, M/SEC	736.0	532.1	448.0	418.8	353.8	345.2	329.8	200.6	

MOLE FRACTIONS

H2O	0.90909	0.90909	0.90909	0.90909	0.77026	0.73080	0.66228	0.20986
*O2	0.09091	0.09091	0.09091	0.09091	0.09091	0.09091	0.09091	0.09091
H2O (L)	0.00000	0.00000	0.00000	0.00000	0.13883	0.17830	0.24681	0.69923

* THERMODYNAMIC PROPERTIES FITTED TO 20000.K

PRODUCTS WHICH WERE CONSIDERED BUT WHOSE MOLE FRACTIONS
WERE LESS THAN 5.000000E-06 FOR ALL ASSIGNED CONDITIONS

*H	HO2	*H2	H2O2	*O
*OH	O3	H2O(s)		

References

- Anon., 1995, "Atomic Weights of the Elements, 1993," *Journal of Physical and Chemical Reference Data*, Vol. 24, No. 4, pp. 1561–1576.
- Chase, M.W., Jr., ed., 1985, JANAF Thermochemical Tables, 3rd Ed., Pts. 1 & 2. (Also, *Journal of Physical and Chemical Reference Data*, Vol. 14, Suppl. 1, 1985).
- Cohen, E.R. and Taylor, B.N., 1987, "The 1986 CODATA Recommended Values of the Fundamental Physical Constants," *National Bureau of Standards Journal of Research*, Vol. 92, Mar.–Apr., pp. 85–95.
- Gordon S., 1970, "Calculation of Theoretical Equilibrium Nozzle Throat Conditions When Velocity of Sound Is Discontinuous," *American Institute of Aeronautics and Astronautics Journal*, Vol. 9, No. 1, pp. 179–182.
- Gordon S. and McBride, B.J., 1976, *Computer Program for Calculation of Complex Chemical Equilibrium Compositions, Rocket Performance, Incident and Reflected Shocks, and Chapman-Jouguet Detonations*, NASA SP-273, Interim Revision.
- Gordon, S., 1982, "Thermodynamic and Transport Combustion Properties of Hydrocarbons With Air. I—Properties in SI Units," NASA TP-1906.
- Gordon, S. and McBride, B.J., 1988, "Finite Area Combustor Theoretical Rocket Performance," NASA TM-100785.
- Gordon S. and McBride, B.J., 1994, *Computer Program for Calculation of Complex Chemical Equilibrium Compositions and Applications. I. Analysis*, NASARP-1311.
- Gupta, R.N., Yos, J.M., Thompson R.A., and Lee, K.P., 1990, *A Review of Reaction Rates and Thermodynamic and Transport Properties for an 11-Species Air Model for Chemical and Thermal Nonequilibrium Calculations to 30 000 K*, NASA RP-1232.
- Lide, D.R., ed., 1992–1993, *CRC Handbook of Chemistry and Physics*, 73rd Ed., CRC Press, Inc., Boca Raton, FL, pp. 6–12.
- McBride, B.J. and Gordon, S., 1992, *Computer Program for Calculating and Fitting Thermodynamic Functions*, NASARP-1271.
- McBride, B.J., Gordon, S., and Reno, M.A., 1993, "Coefficients for Calculating Thermodynamic and Transport Properties of Individual Species," NASATM-4513.
- McBride, B.J., Reno, M.A., and Gordon, S., 1994, "CET93 and CETPC: An Interim Updated Version of the NASA Lewis Computer Program for Calculating Complex Chemical Equilibria With Applications," NASATM-4557.
- Svehla, R.A. and McBride, B.J., 1973, "FORTRAN IV Computer Program for the Calculation of Thermodynamic and Transport Properties of Complex Chemical Systems," NASATND-7056.
- Svehla, R.A., 1995, "Transport Coefficients for the NASA Lewis Chemical Equilibrium Program," NASA TM-4647.
- Svehla, R.A., 1996, Private communication.

REPORT DOCUMENTATION PAGE			Form Approved OMB No. 0704-0188	
Public reporting burden for this collection of information is estimated to average 1 hour per response, including the time for reviewing instructions, searching existing data sources, gathering and maintaining the data needed, and completing and reviewing the collection of information. Send comments regarding this burden estimate or any other aspect of this collection of information, including suggestions for reducing this burden, to Washington Headquarters Services, Directorate for Information Operations and Reports, 1215 Jefferson Davis Highway, Suite 1204, Arlington, VA 22202-4302, and to the Office of Management and Budget, Paperwork Reduction Project (0704-0188), Washington, DC 20503.				
1. AGENCY USE ONLY (Leave blank)	2. REPORT DATE June 1996	3. REPORT TYPE AND DATES COVERED Reference Publication		
4. TITLE AND SUBTITLE Computer Program for Calculation of Complex Chemical Equilibrium Compositions and Applications II. Users Manual and Program Description			5. FUNDING NUMBERS WU-505-62-52	
6. AUTHOR(S) Bonnie J. McBride and Sanford Gordon				
7. PERFORMING ORGANIZATION NAME(S) AND ADDRESS(ES) National Aeronautics and Space Administration Lewis Research Center Cleveland, Ohio 44135-3191			8. PERFORMING ORGANIZATION REPORT NUMBER E-8017-1	
9. SPONSORING/MONITORING AGENCY NAME(S) AND ADDRESS(ES) National Aeronautics and Space Administration Washington, D.C. 20546-0001			10. SPONSORING/MONITORING AGENCY REPORT NUMBER NASA RP-1311	
11. SUPPLEMENTARY NOTES Bonnie J. McBride, NASA Lewis Research Center, and Sanford Gordon, Sanford Gordon and Associates, Cleveland, Ohio. Responsible person, Bonnie J. McBride, organization code 2670, (216) 433-5870.				
12a. DISTRIBUTION/AVAILABILITY STATEMENT Unclassified - Unlimited Subject Categories 20 and 25 This publication is available from the NASA Center for Aerospace Information, (301) 621-0390.			12b. DISTRIBUTION CODE	
13. ABSTRACT (Maximum 200 words) This users manual is the second part of a two-part report describing the NASA Lewis CEA (Chemical Equilibrium with Applications) program. The program obtains chemical equilibrium compositions of complex mixtures with applications to several types of problems. The topics presented in this manual are (1) details for preparing input data sets; (2) a description of output tables for various types of problems; (3) the overall modular organization of the program with information on how to make modifications; (4) a description of the function of each subroutine; (5) error messages and their significance; and (6) a number of examples that illustrate various types of problems handled by CEA and that cover many of the options available in both input and output. Seven appendices give information on the thermodynamic and thermal transport data used in CEA; some information on common variables used in or generated by the equilibrium module; and output tables for 14 example problems. The CEA program was written in ANSI standard FORTRAN 77. CEA should work on any system with sufficient storage. There are about 6300 lines in the source code, which uses about 225 kilobytes of memory. The compiled program takes about 975 kilobytes.				
14. SUBJECT TERMS Chemical equilibrium; Combustion products; Combustion temperatures; Computer program; Thermodynamic mixture properties; Thermal transport properties; Rocket performance			15. NUMBER OF PAGES 178	
			16. PRICE CODE A09	
17. SECURITY CLASSIFICATION OF REPORT Unclassified	18. SECURITY CLASSIFICATION OF THIS PAGE Unclassified	19. SECURITY CLASSIFICATION OF ABSTRACT Unclassified	20. LIMITATION OF ABSTRACT	