

# INSTALLATION AND WIRING

---



# CHAPTER 8

## In This Chapter...

<b>Safety Guidelines</b> .....	<b>8-2</b>
Plan for Safety .....	8-2
Three Levels of Protection .....	8-3
Emergency Stops.....	8-3
Emergency Power Disconnect .....	8-4
Orderly System Shutdown.....	8-4
Class 1, Division 2, Approval .....	8-4
<b>Mounting Guidelines</b> .....	<b>8-5</b>
Base Dimensions .....	8-5
Panel Mounting and Layout.....	8-6
Enclosures .....	8-7
Environmental Specifications .....	8-8
Marine Use.....	8-8
Agency Approvals .....	8-8
24VDC Power Bases .....	8-8
<b>Installing Bases for Do-more</b> .....	<b>8-9</b>
Mounting the Base.....	8-9
Using Mounting Rails .....	8-9
<b>Installing Components in the Base</b> .....	<b>8-10</b>
<b>Base Wiring Guidelines</b> .....	<b>8-11</b>
Base Wiring .....	8-11
<b>I/O Modules Position and Wiring</b> .....	<b>8-12</b>
Slot Numbering.....	8-12
Module Placement Restrictions.....	8-12
Wiring the Different Module Connectors.....	8-13
I/O Wiring Checklist .....	8-14

<b>ZIPLink Wiring System.....</b>	<b>8-15</b>
<b>I/O Wiring Strategies .....</b>	<b>8-17</b>
PLC Isolation Boundaries .....	8-17
Powering I/O Circuits with the Auxiliary Supply .....	8-18
Powering I/O Circuits Using Separate Supplies .....	8-19
Sinking / Sourcing Concepts .....	8-20
I/O “Common” Terminal Concepts.....	8-21
Connecting DC I/O to “Solid State” Field Devices.....	8-22
Solid State Input Sensors.....	8-22
Solid State Output Loads.....	8-22
Relay Output Guidelines.....	8-24
Relay Outputs – Transient Suppression for Inductive Loads in a Control System.....	8-25

## Safety Guidelines



**NOTE:** Products with CE marks perform their required functions safely and adhere to relevant standards as specified by CE directives, provided they are used according to their intended purpose and that the instructions in this manual are followed. The protection provided by the equipment may be impaired if this equipment is used in a manner not specified in this manual. A listing of our international affiliates is available on our Web site: <http://www.automationdirect.com>



**WARNING:** Providing a safe operating environment for personnel and equipment is your responsibility and should be your primary goal during system planning and installation. Automation systems can fail and may result in situations that can cause serious injury to personnel and/or damage equipment. Do not rely on the automation system alone to provide a safe operating environment. Sufficient emergency circuits should be provided to stop either partially or totally the operation of the PLC or the controlled machine or process. These circuits should be routed outside the PLC in the event of controller failure, so that independent and rapid shutdown are available. Devices, such as “mushroom” switches or end of travel limit switches, should operate motor starter, solenoids, or other devices without being processed by the PLC. These emergency circuits should be designed using simple logic with a minimum number of highly reliable electromechanical components. Every automation application is different, so there may be special requirements for your particular application. Make sure all national, state, and local government requirements are followed for the proper installation and use of your equipment.

### Plan for Safety

The best way to provide a safe operating environment is to make personnel and equipment safety part of the planning process. You should examine every aspect of the system to determine which areas are critical to operator or machine safety.

If you are not familiar with PLC system installation practices, or your company does not have established installation guidelines, you should obtain additional information from the following sources.

- NEMA — The National Electrical Manufacturers Association, located in Washington, D.C., publishes many different documents that discuss standards for industrial control systems. You can order these publications directly from NEMA. Some of these include:
  - ICS 1, General Standards for Industrial Control and Systems
  - ICS 3, Industrial Systems
  - ICS 6, Enclosures for Industrial Control Systems
- NEC — The National Electrical Code provides regulations concerning the installation and use of various types of electrical equipment. Copies of the NEC Handbook can often be obtained from your local electrical equipment distributor or your local library.
- Local and State Agencies — many local governments and state governments have additional requirements above and beyond those described in the NEC Handbook. Check with your local Electrical Inspector or Fire Marshall office for information.

## Three Levels of Protection

The publications mentioned provide many ideas and requirements for system safety. At a minimum, you should follow these regulations. Also, you should use the following techniques, which provide three levels of system control.

- Emergency stop switch for disconnecting system power
- Mechanical disconnect for output module power
- Orderly system shutdown sequence in the PLC control program

## Emergency Stops

It is recommended that emergency stop circuits be incorporated into the system for every machine controlled by a PLC. For maximum safety in a PLC system, these circuits must not be wired into the controller, but should be hardwired external to the PLC. The emergency stop switches should be easily accessed by the operator and are generally wired into a master control relay (MCR) or a safety control relay (SCR) that will remove power from the PLC I/O system in an emergency.

MCRs and SCRs provide a convenient means for removing power from the I/O system during an emergency situation. By de-energizing an MCR (or SCR) coil, power to the input (optional) and output devices is removed. This event occurs when any emergency stop switch opens. However, the PLC continues to receive power and operate even though all its inputs and outputs are disabled.

The MCR circuit could be extended by placing a PLC fault relay (closed during normal PLC operation) in series with any other emergency stop conditions. This would cause the MCR circuit to drop the PLC I/O power in case of a PLC failure (memory error, I/O communications error, etc.).

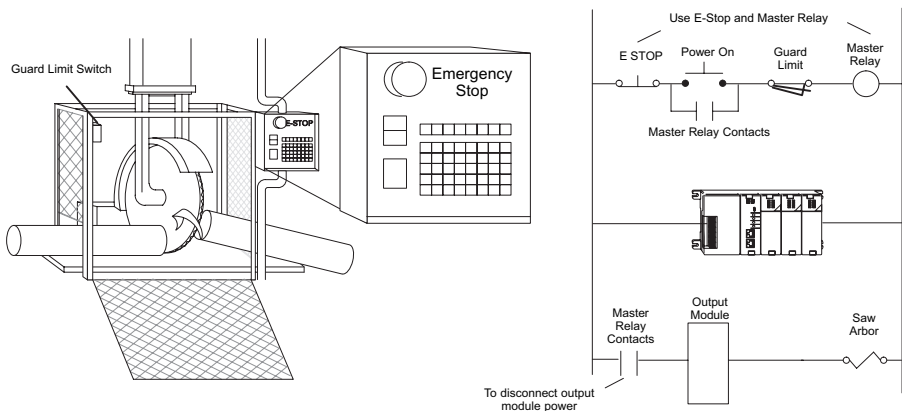

### Emergency Power Disconnect

A properly rated emergency power disconnect should be used to power the PLC controlled system as a means of removing the power from the entire control system. After an emergency shutdown or any other type of power interruption, there may be requirements that must be met before the PLC control program can be restarted. For example, there may be specific register values that must be established (or maintained from the state prior to the shutdown) before operations can resume. In this case, you may want to use retentive memory locations, or include constants in the control program to insure a known starting point.

### Orderly System Shutdown

Ideally, the first level of fault detection is the PLC control program, which can identify machine problems. Certain shutdown sequences should be performed. The types of problems are usually things such as jammed parts, etc. that do not pose a risk of personal injury or equipment damage.

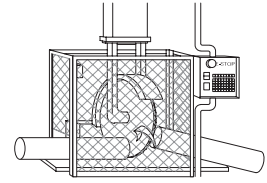

**WARNING:** The control program *must not* be the only form of protection for any problems that may result in a risk of personal injury or equipment damage.

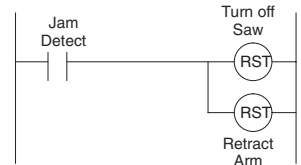

### Class 1, Division 2, Approval

This equipment is suitable for use in Class 1, Division 2, Zone 2, groups A, B, C and D or non-hazardous locations only.



**WARNING:** Explosion Hazard! Substitution of components may impair suitability for Class 1, Division 2, Zone 2.



**WARNING:** Explosion Hazard - Do not disconnect equipment unless power has been switched off or the area is known to be non-hazardous.



**WARNING:** All Do-more products used with connector accessories must use R/C (ECBT2) mating plugs. All mating plugs must have suitable ratings for the devices.

# Mounting Guidelines

Before installing the PLC system you will need to know the dimensions of the components considered. The diagrams on the following pages provide the component dimensions to use in defining your enclosure specifications. Remember to leave room for potential expansion.



**NOTE:** If you are using other components in your system, refer to the appropriate manual to determine how those units can affect mounting dimensions.

## Base Dimensions

The following information shows the proper mounting dimensions. The height dimension is the same for all bases. The depth varies depending on your choice of I/O module. The length varies as the number of slots increase. Make sure you have followed the installation guidelines for proper spacing.

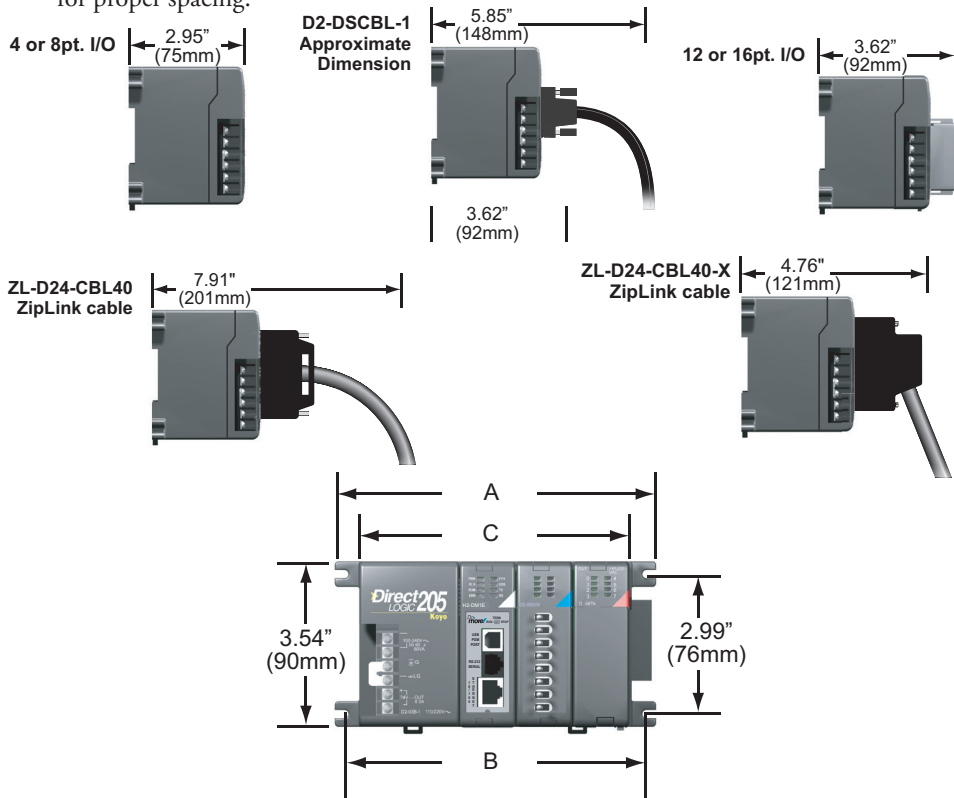

Base	A (Base Total Width)		B (Mounting Hole)		C (Component Width)	
	Inches	Millimeters	Inches	Millimeters	Inches	Millimeters
3-slot	6.77	172	6.41	163	5.8	148
4-slot	7.99	203	7.63	194	7.04	179
6-slot	10.43	265	10.07	256	9.48	241
9-slot	14.09	358	13.74	349	13.14	334

## Panel Mounting and Layout

It is important to design your panel properly to help ensure the components operate within their environmental and electrical limits. The system installation should comply with all appropriate electrical codes and standards. It is important the system also conforms to the operating standards for the application to insure proper performance. The diagrams below reference the items in the following list.

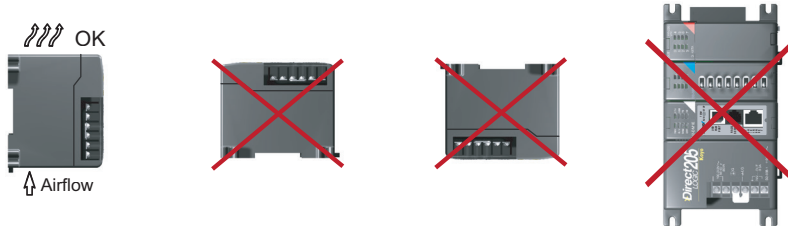

1. Mount the bases horizontally to provide proper ventilation.
2. If you place more than one base in a cabinet, there should be a minimum of 7.2 in. (183mm) between bases.
3. Provide a minimum clearance of 2in. (50mm) between the base and all sides of the cabinet. There should also be at least 1.2 in. (30mm) of clearance between the base and any wiring ducts.
4. There must be a minimum of 2in. (50mm) clearance between the panel door and the nearest component.



**NOTE:** The cabinet configuration below is not suitable for EU installations. Refer to Appendix B European Union Directives.

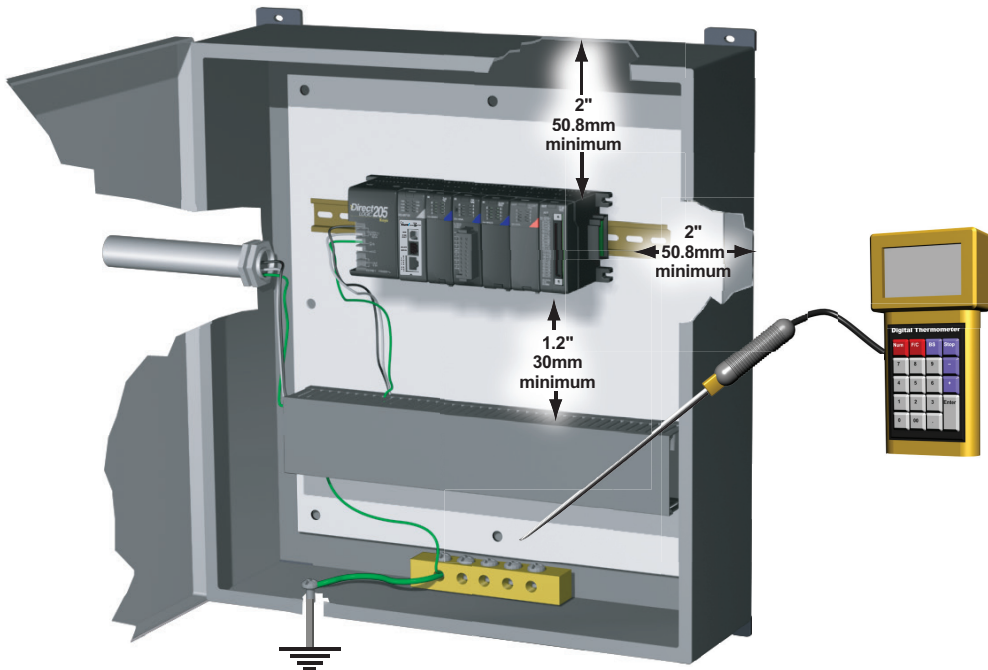

5. The ground terminal on the Do-more base must be connected to a single point ground. Use copper stranded wire to achieve a low impedance. Copper eye lugs should be crimped and soldered to the ends of the stranded wire to ensure good surface contact. Remove anodized finishes and use copper lugs and star washers at termination points. A general rule is to achieve a 0.1 ohm of DC resistance between the base and the single point ground.
6. There must be a single point ground (i.e. copper bus bar) for all devices in the panel requiring an earth ground return. The single point of ground must be connected to the panel ground termination. The panel ground termination must be connected to earth ground. For this connection you should use #12 AWG stranded copper wire as a minimum. Minimum wire sizes, color coding, and general safety practices should comply with appropriate electrical codes and standards for your region. A good common ground reference (Earth ground) is essential for proper operation of the Do-more. There are several methods of providing an adequate common ground reference, including:
  - a) Installing a ground rod as close to the panel as possible.
  - b) Connection to incoming power system ground.
7. Properly evaluate any installations where the ambient temperature may approach the lower or upper limits of the specifications. Place a temperature probe in the panel, close the door and operate the system until the ambient temperature has stabilized. If the ambient temperature is not within the operating specification for the Do-more system, measures such as installing a cooling/heating source must be taken to get the ambient temperature within the operating specifications.
8. Device mounting bolts and ground braid termination bolts should be #10 copper bolts or equivalent. Tapped holes instead of nut-bolt arrangements should be used whenever possible. To ensure good contact on termination areas impediments such as paint, coating or corrosion should be removed in the area of contact.
9. The Do-more system is designed to be powered by 110/220 VAC, 24 VDC, or 125 VDC normally available throughout an industrial environment. Electrical power in some areas where the PLCs are installed is not always stable and storms can cause power surges. Due to this, powerline filters are recommended for protecting the PLCs from power surges.

### Enclosures

Your selection of a proper enclosure is important to ensure safe and proper operation of your Do-more system. Applications of Do-more systems vary and may require additional features. The minimum considerations for enclosures include:

- Conformance to electrical standards
- Protection from the elements in an industrial environment
- Common ground reference
- Maintenance of specified ambient temperature
- Access to equipment
- Security or restricted access
- Sufficient space for proper installation and maintenance of equipment



## Environmental Specifications

The following table lists the environmental specifications that generally apply to the Do-more system (CPU, Bases, I/O Modules). I/O module operation may fluctuate depending on the ambient temperature and your application. Please refer to the appropriate I/O module specifications for the temperature derating curves applying to specific modules.

Specification	Rating
<b>Storage temperature</b>	-4° F to 158° F (-20° C to 70° C)
<b>Ambient operating temperature</b>	32° F to 131° F (0° C to 55° C)
<b>Ambient humidity*</b>	30% – 95% relative humidity (Non-condensing)
<b>Vibration resistance</b>	MIL STD 810C, Method 514.2
<b>Shock resistance</b>	MIL STD 810C, Method 516.2
<b>Noise immunity</b>	NEMA (ICS3-304)
<b>Atmosphere</b>	No corrosive gases

\* Equipment will operate below 30% humidity. However, static electricity problems occur much more frequently at lower humidity levels. Make sure you take adequate precautions when you touch the equipment. Consider using ground straps, anti-static floor coverings, etc., if you use the equipment in low humidity environments.

## Marine Use

American Bureau of Shipping (ABS) certification requires flame-retarding insulation as per 4-8-3/5.3.6(a). ABS will accept Navy low smoke cables, cable qualified to NEC “Plenum rated” (fire resistant level 4), or other similar flammability resistant rated cables. Use cable specifications for your system that meet a recognized flame retardant standard (i.e. UL, IEEE, etc.) including evidence of cable test certification (i.e. tests certificate, UL file number, etc.).



**NOTE:** Wiring needs to be “low smoke” per the above paragraph. Teflon coated wire is also recommended.

## Agency Approvals

Some applications require agency approvals. Typical agency approvals which your application may require are:

- UL (Underwriters’ Laboratories, Inc.)
- CSA (Canadian Standards Association)
- FM (Factory Mutual Research Corporation)
- cUL (Canadian Underwriters’ Laboratories, Inc.)

## 24VDC Power Bases

Follow these additional installation guidelines when installing D2-03BDC1-1, D2-04BDC1-1, D2-06BDC1-1 and D2-09BDC1-1 bases:

- Install these bases in compliance with the enclosure, mounting, spacing, and segregation requirements of the ultimate application.
- These bases must be used within their marked ratings.
- These bases are intended to be installed within an enclosure rated at least IP54.
- Provisions should be made to prevent the rated voltage being exceeded by transient disturbances of more than 40%.

# Installing Bases for Do-more

## Mounting the Base

All I/O configurations of the Do-more may use any of the base configurations. The bases are secured to the equipment panel or mounting location using four M4 screws in the corner tabs of the base. The full mounting dimensions are given in the previous section on Mounting Guidelines.



**WARNING:** To minimize the risk of electrical shock, personal injury, or equipment damage, always disconnect the system power before installing or removing any system component.

## Using Mounting Rails



The bases can also be secured to the cabinet by using mounting rails. You should use rails that conform to DIN EN standard 50 022. Refer to our catalog for a complete line of DIN rail, DINnectors and DIN rail mounted apparatus.

These rails are approximately 35mm high, with a depth of 7.5 mm. If you mount the base on a rail, you should also consider using end brackets on each end of the rail. The end brackets help keep the base from sliding horizontally along the rail. This helps minimize the possibility of accidentally pulling the wiring loose.

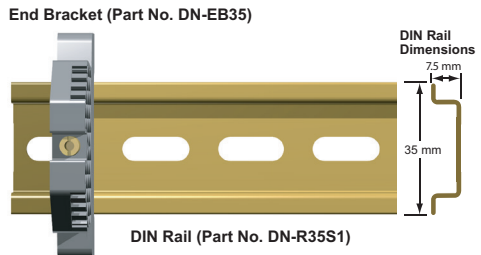

If you examine the bottom of the base, you'll notice small retaining clips. To secure the

base to a DIN rail, place the base onto the rail and gently push up on the retaining clips. The clips lock the base onto the rail. To remove the base, pull down on the retaining clips, lift up on the base slightly, and pull it away from the rail.

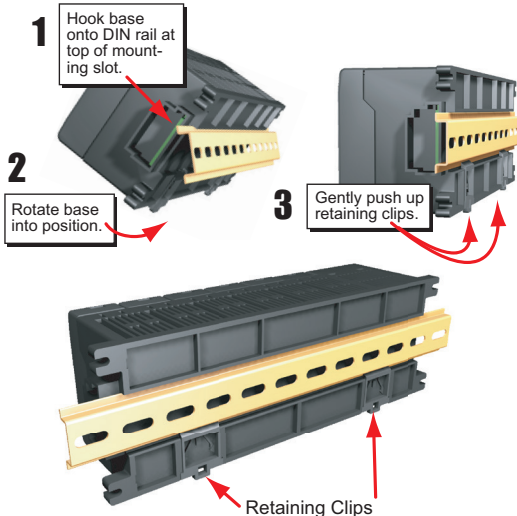

## Installing Components in the Base

To insert components into the base: first slide the module retaining clips to the out position and align the PC board(s) of the module with the grooves on the top and bottom of the base. Push the module straight into the base until it is firmly seated in the backplane connector. Once the module is inserted into the base, push in the retaining clips to firmly secure the module to the base.

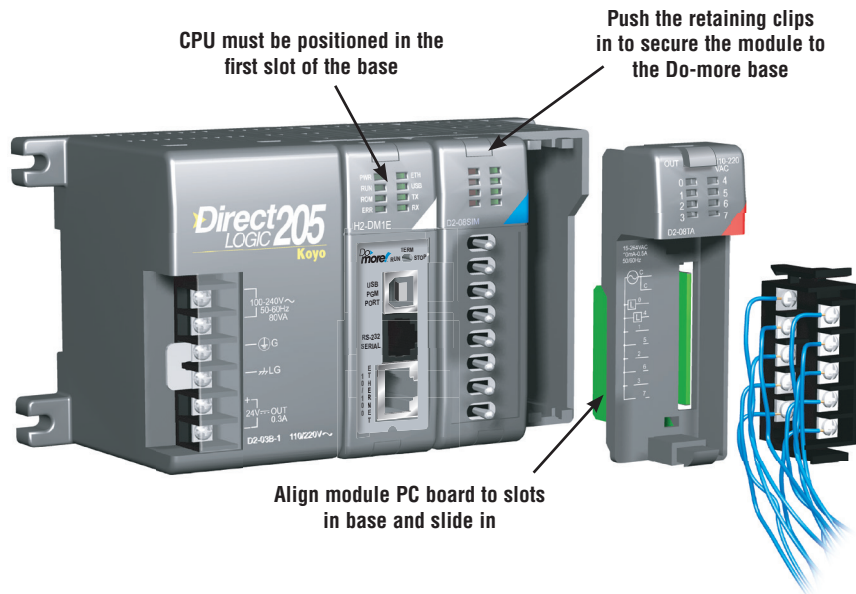

8



**WARNING:** To minimize the risk of electrical shock, personal injury, or equipment damage, always disconnect the system power before installing or removing any system component.

## Base Wiring Guidelines

### Base Wiring

The following diagrams show the terminal connections located on the power supply of the Do-more bases. The base terminals can accept up to 16 AWG. You may be able to use larger wiring depending on the type of wire used, but 16 AWG is the recommended size. Do not overtighten the connector screws; the recommended torque value is 7.81 lb-in (0.882 N·m).

110/220 VAC Base Terminal Strip

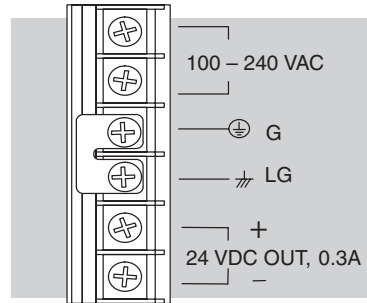

**NOTE:** You can connect either a 115VAC or 220VAC supply to the AC terminals without the need of special wiring or jumpers.

8

12/24 VDC Base Terminal Strip

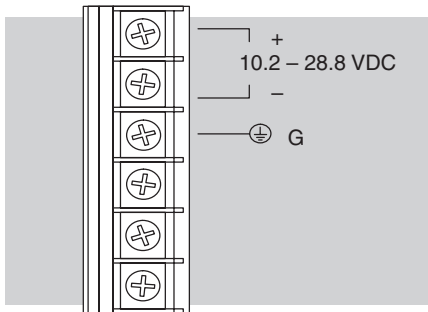

125 VDC Base Terminal Strip

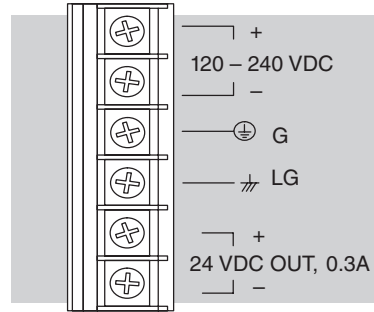

**WARNING:** Once the power wiring is connected, install the plastic protective cover. When the cover is removed there is a risk of electrical shock if you accidentally touch the wiring or wiring terminals.

## I/O Modules Position and Wiring

### Slot Numbering

The bases provide different numbers of slots for use with the I/O modules. You may notice the bases refer to 3-slot, 4-slot, etc. One of the slots is dedicated to the CPU, so you always have one less I/O slot. For example, you have five I/O slots with a 6-slot base. The I/O slots are numbered 0–4. The CPU slot always contains a PLC CPU or other CPU-slot controller and is not numbered.

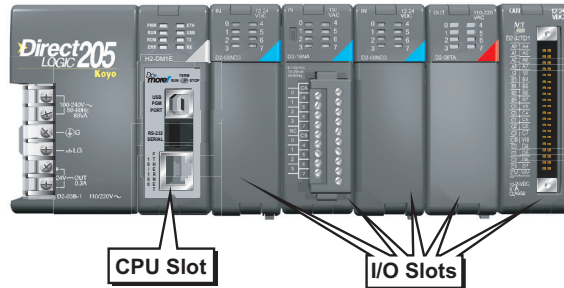

### Module Placement Restrictions

The following table lists the valid locations for all types of modules in a Do-more system:

Module/Unit	Local CPU Base	Ethernet Remote I/O Base
<b>CPUs</b>	CPU Slot Only	
<b>DC Input Modules</b>	X	X
<b>AC Input Modules</b>	X	X
<b>DC Output Modules</b>	X	X
<b>AC Output Modules</b>	X	X
<b>Relay Output Modules</b>	X	X
<b>Analog Input and Output Modules</b>	X	X
<b>Ethernet Remote I/O</b>		
<b>Ethernet Remote Master</b>	X	
<b>CPU Interface</b>		
<b>Ethernet Base Controller</b>		CPU Slot Only
<b>Specialty Modules</b>		
<b>Counter I/O</b>	X	
<b>Ethernet Communications</b>	X	
<b>Simulator</b>	X	X
<b>Filler</b>	X	X

### Wiring the Different Module Connectors

There are two types of module connectors for the Do-more I/O. Some modules have normal screw terminal connectors. Other modules have connectors with recessed screws. The recessed screws help minimize the risk of someone accidentally touching active wiring.

Both types of connectors can be easily removed. If you examine the connectors closely, you'll notice there are squeeze tabs on the top and bottom. To remove the terminal block, press the squeeze tabs and pull the terminal block away from the module.

We also have DIN rail mounted terminal blocks, DINnectors (refer to our catalog for a complete listing of all available products). *ZIPLink* systems come with special pre-assembled cables with the I/O connectors installed and wired.



**WARNING:** For some modules, field device power may still be present on the terminal block even though the PLC system is turned off. To minimize the risk of electrical shock, check all field device power before you remove the connector.

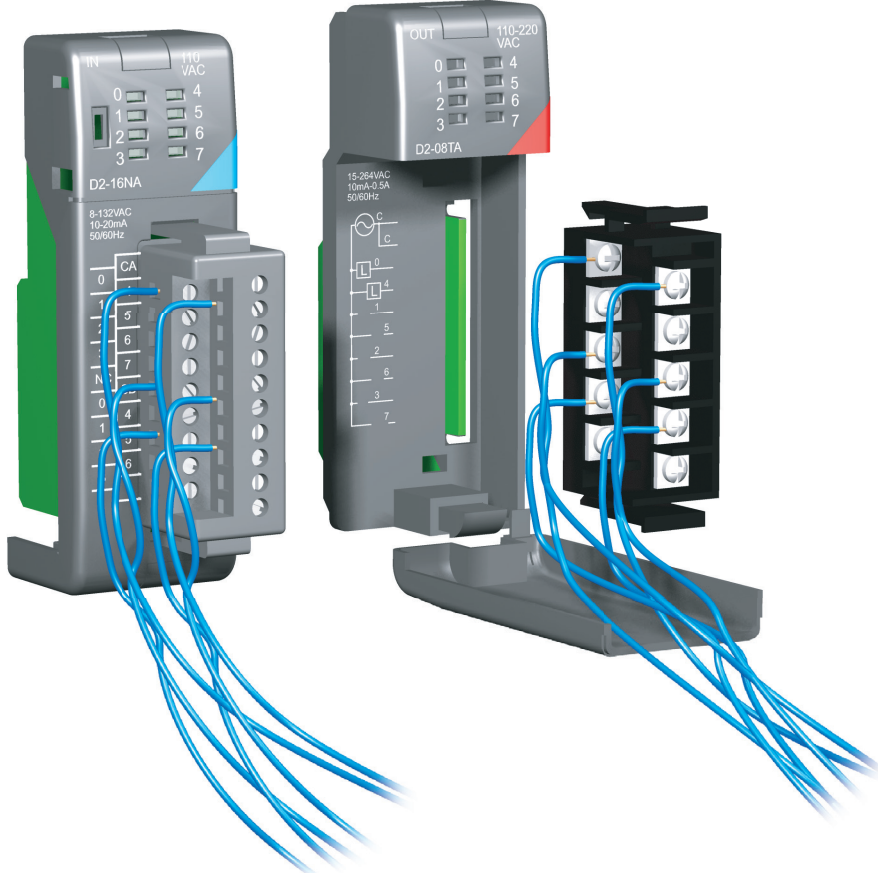

## I/O Wiring Checklist

Use the following guidelines when wiring the I/O modules in your system.

1. There is a limit to the size of wire the modules can accept. The table below lists the suggested AWG for each module type. When making terminal connections, follow the suggested torque values.

Module type	Suggested AWG Range	Suggested Torque
4 point	16–24 AWG	7.81 lb-in (0.882 N-m)
8 point	16–24 AWG	7.81 lb-in (0.882 N-m)
12 point	16–24 AWG	2.65 lb-in (0.3 N-m)
16 point	16–24 AWG	2.65 lb-in (0.3 N-m)



**NOTE:** 16 AWG Type TFFN or Type MTW is recommended. Other types of 16 AWG may be acceptable, but it really depends on the thickness and stiffness of the wire insulation. If the insulation is too thick or stiff and a majority of the module's I/O points are used, then the plastic terminal cover may not close properly or the connector may pull away from the module. This applies especially for high temperature thermoplastics such as THHN.

2. Always use a continuous length of wire, do not combine wires to attain a needed length.
3. Use the shortest possible wire length.
4. Use wire trays for routing where possible.
5. Avoid running wires near high energy wiring. Also, avoid running input wiring close to output wiring where possible.
6. To minimize voltage drops when wires must run a long distance, consider using multiple wires for the return line.
7. Avoid running DC wiring in close proximity to AC wiring where possible.
8. Avoid creating sharp bends in the wires.
9. To reduce the risk of having a module with a blown fuse, we suggest you add external fuses to your I/O wiring. A fast blow fuse, with a lower current rating than the I/O module fuse can be added to each common, or a fuse with a rating of slightly less than the maximum current per output point can be added to each output. Refer to our catalog for a complete line of DINnectors, DIN rail mounted fuse blocks.



DINnect External Fuses  
(DIN rail mounted Fuses)

## ZIPLink Wiring System

The ZIPLink I/O connector systems allows quick and easy connections using cables that are prewired to the I/O module terminal blocks at one end and plug into a ZIPLink connector module terminal block at the other end.

Use the following tables to specify your ZIPLink wiring system. See the ZIPLink section of the catalog for more details.

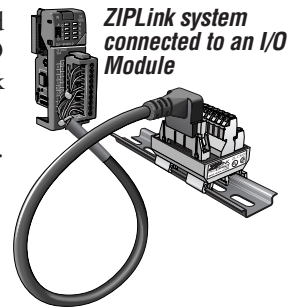

**NOTE:** ZIPLink Connector Modules and ZIPLink Cables specifications are in the ZIPLink catalog section.

8

Do-more PLC Input Module ZIPLink Selector				
PLC		ZIPLink		
Input Module	# of Terms	Component	Module	Cable †
D2-08ND3	10	Feedthrough	ZL-RTB20	ZL-D2-CBL10*
D2-16ND3-2	19	Feedthrough	ZL-RTB20	ZL-D2-CBL19*
		Sensor	ZL-LTB16-24	ZL-D2-CBL19*
D2-32ND3 <sup>1</sup>	40	Feedthrough	ZL-RTB40	ZL-D24-CBL40*
				ZL-D24-CBL40*X
D2-32ND3-2 <sup>1</sup>	40	Sensor	ZL-LTB32-24	ZL-D24-CBL40*
				ZL-D24-CBL40*X
D2-08NA-1	10	Feedthrough	ZL-RTB20	ZL-D2-CBL10*
D2-08NA-2	10	Feedthrough	ZL-RTB20	ZL-D2-CBL10*
D2-16NA	19	Feedthrough	ZL-RTB20	ZL-D2-CBL19*

† X in the part number represents a 45° angle plug

\* Select the cable length by replacing the \* with: Blank = 0.5 m, 1 = 1.0 m, or -2 = 2.0 m.

<sup>1</sup> To make a custom cable for the 32-point modules, use: Ribbon-style Connector ZL-D24-CON-R, Solder-style 180° connector ZL-D24-CON or Solder-style 45° connector ZL-D24-CON-X

<sup>2</sup> The F2-04RTD and F2-04THM modules are not supported by the ZIPLink wiring system.

Do-more PLC Analog Module ZIPLink Selector				
PLC		ZIPLink		
Analog Module	# of Terms	Component	Module	Cable
F2-04AD-1	10	Feedthrough	ZL-RTB20	ZL-D2-CBL10*
F2-08AD-1	10	Feedthrough	ZL-RTB20	ZL-D2-CBL10*
F2-04AD-2	10	Feedthrough	ZL-RTB20	ZL-D2-CBL10*
F2-08AD-2	10	Feedthrough	ZL-RTB20	ZL-D2-CBL10*
F2-02DA-1	10	Feedthrough	ZL-RTB20	ZL-D2-CBL10*
F2-02DA-1L	10	Feedthrough	ZL-RTB20	ZL-D2-CBL10*
F2-02DAS-1	10	Feedthrough	ZL-RTB20	ZL-D2-CBL10*
F2-08DA-1	19	Feedthrough	ZL-RTB20	ZL-D2-CBL19*
F2-02DA-2	10	Feedthrough	ZL-RTB20	ZL-D2-CBL10*
F2-02DA-2L	10	Feedthrough	ZL-RTB20	ZL-D2-CBL10*
F2-02DAS-2	10	Feedthrough	ZL-RTB20	ZL-D2-CBL10*
F2-08DA-2	10	Feedthrough	ZL-RTB20	ZL-D2-CBL10*
F2-4AD2DA	10	Feedthrough	ZL-RTB20	ZL-D2-CBL10*
F2-8AD4DA-1	19	Feedthrough	ZL-RTB20	ZL-D2-CBL19*
F2-8AD4DA-2	19	Feedthrough	ZL-RTB20	ZL-D2-CBL19*
F2-04RTD <sup>2</sup>	Matched Only			See Note 2
F2-04THM <sup>2</sup>	Matched Only			See Note 2

Do-more PLC Combo In/Out Module ZIPLink Selector				
PLC		ZIPLink		
Combo Module	# of Terms	Component	Module	Cable
D2-08CDR	10	Feedthrough	ZL-RTB20	ZL-D2-CBL10*



Do-more PLC Output Module ZI/Link Selector				
PLC		ZI/Link		
Output Module	# of Terms	Component	Module	Cable †
D2-04TD1 <sup>2</sup>	10	Feedthrough	ZL-RTB20	ZL-D2-CBL10*
D2-08TD1	10	Feedthrough	ZL-RTB20	ZL-D2-CBL10*
D2-08TD2	10	Feedthrough	ZL-RTB20	ZL-D2-CBL10*
D2-16TD1-2	19	Feedthrough	ZL-RTB20	ZL-D2-CBL19*
		Fuse	ZL-RFU20 <sup>4</sup>	ZL-D2-CBL19*
		Relay	ZL-RRL16-24-1	ZL-D2-CBL19*
D2-16TD2-2	19	Feedthrough	ZL-RTB20	ZL-D2-CBL19*
		Fuse	ZL-RFU20 <sup>4</sup>	ZL-D2-CBL19*
		Relay	ZL-RRL16-24-2	ZL-D2-CBL19*
F2-16TD1P	19	Feedthrough	ZL-RTB20	ZL-D2-CBL19*
		Relay	ZL-RRL16-24-1	ZL-D2-CBL19*
F2-16TD2P	19	Feedthrough	ZL-RTB20	ZL-D2-CBL19*
		Relay	ZL-RRL16-24-2	ZL-D2-CBL19*
D2-32TD1 <sup>1</sup>	40	Feedthrough	ZL-RTB40	ZL-D24-CBL40*
				ZL-D24-CBL40*X
		Fuse	ZL-RFU40 <sup>4</sup>	ZL-D24-CBL40*
D2-32TD2 <sup>1</sup>	40	Feedthrough	ZL-RTB40	ZL-D24-CBL40*
				ZL-D24-CBL40*X
		Fuse	ZL-RFU40 <sup>4</sup>	ZL-D24-CBL40*
				ZL-D24-CBL40*X
D2-08TA	10	Feedthrough	ZL-RTB20	ZL-D2-CBL10*
F2-08TA	10	Feedthrough	ZL-RTB20	ZL-D2-CBL10*
D2-12TA	19	Feedthrough	ZL-RTB20	ZL-D2-CBL19*
		Fuse	ZL-RFU20 <sup>4</sup>	ZL-D2-CBL19*
D2-04TRS <sup>2</sup>	10	Feedthrough	ZL-RTB20	ZL-D2-CBL10*
D2-08TR	10	Feedthrough	ZL-RTB20	ZL-D2-CBL10*
F2-08TRS <sup>2</sup>	19	Feedthrough	ZL-RTB20	ZL-D2-CBL19*
F2-08TR <sup>3</sup>	10	Feedthrough	ZL-RTB20	ZL-D2-CBL10*
D2-12TR	19	Feedthrough	ZL-RTB20	ZL-D2-CBL19*
		Fuse	ZL-RFU20 <sup>4</sup>	ZL-D2-CBL19*

† X in the part number represents a 45° angle plug

\* Select the cable length by replacing the \* with: Blank = 0.5 m, -1 = 1.0 m, or -2 = 2.0 m.

<sup>1</sup> To make a custom cable for the 32-point modules, use: Ribbon-style Connector ZL-D24-CON-R, Solder-style 180° connector ZL-D24-CON or Solder-style 45° connector ZL-D24-CON-X

<sup>2</sup> Caution: The D2-04TD1, D2-04TRS, and F2-08TRS outputs are derated not to exceed module specs 2A per point and 2A per common when used with the ZIPLink wiring system.

<sup>3</sup> The F2-08TR outputs are derated not to exceed 2A per point and 4A per common when used with the ZIPLink wiring system.

<sup>4</sup> Note: Fuses (5 x 20 mm) are not included. See Edison Electronic Fuse section for (5 x 20 mm) fuse. S500 and GMA electronic circuit protection for fast-acting maximum protection. S506 and GMC electronic circuit protection for time-delay performance. Ideal for inductive circuits. To ensure proper operation, do not exceed the voltage and current rating of ZIPLink module. ZL-RFU20 = 2A per circuit; ZL-RFU40 = 400mA per circuit.

## I/O Wiring Strategies

The Do-more PLC system is very flexible and will work in many different wiring configurations. By studying this section before actual installation, you can probably find the best wiring strategy for your application. This will help to lower system cost, wiring errors, and avoid safety problems.

### PLC Isolation Boundaries

PLC circuitry is divided into three main regions separated by isolation boundaries, shown in the drawing below. Electrical isolation provides safety, so that a fault in one area does not damage another. A transformer in the power supply provides isolation between the primary and secondary sides. Opto-couplers provide isolation in Input and Output circuits. This isolates logic circuitry from the field side, where factory machinery connects. Note the discrete inputs are isolated from the discrete outputs, because each is isolated from the logic side. Isolation boundaries protect the operator interface (and the operator) from power input faults or field wiring faults. When wiring a PLC, it is extremely important to avoid making external connections that connect logic side circuits to any other.

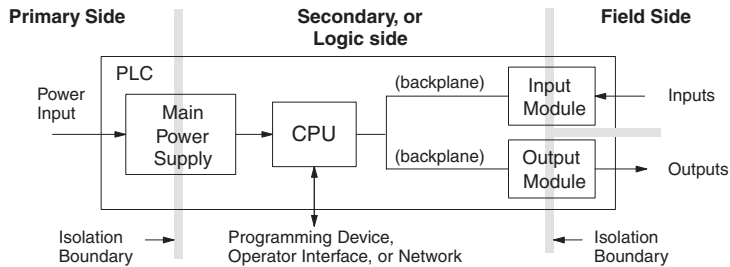

In addition to the basic circuits covered above, AC-powered and 125VDC bases include an auxiliary +24VDC power supply with its own isolation boundary. Since the supply output is isolated from the other three circuits, it can power input and/or output circuits!

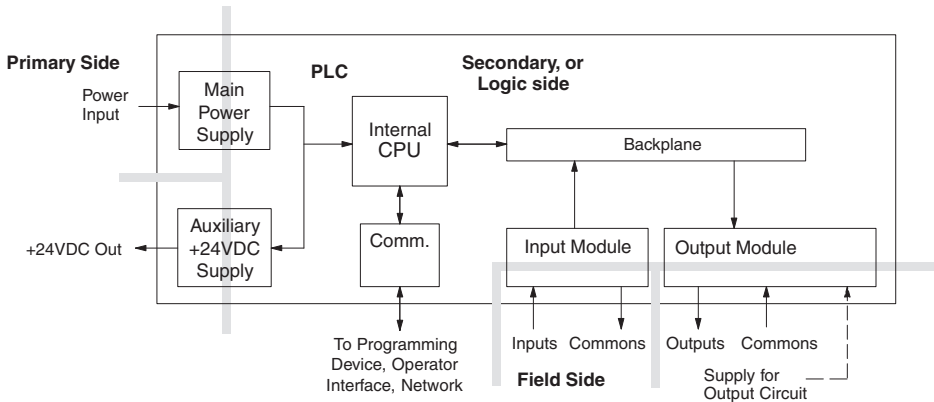

## Powering I/O Circuits with the Auxiliary Supply

In some cases, using the built-in auxiliary +24VDC supply can result in a cost savings for your control system. It can power combined loads up to 300mA. Be careful not to exceed the current rating of the supply. If you are the system designer for your application, you may be able to select and design in field devices which can use the +24VDC auxiliary supply.

All AC powered and 125VDC bases feature the internal auxiliary supply. If input devices AND output loads need +24VDC power, the auxiliary supply may be able to power both circuits as shown in the following diagram.

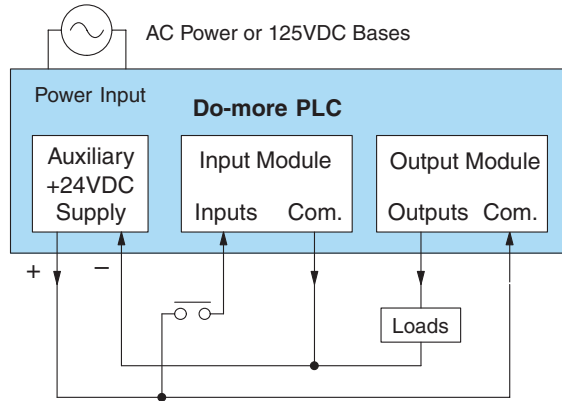

The 12/24VDC powered bases are designed for application environments in which low-voltage DC power is more readily available than AC. These include a wide range of battery-powered applications, such as remotely-located control, in vehicles, portable machines, etc. For this application type, all input devices and output loads typically use the same DC power source. Typical wiring for DC-powered applications is shown in the following diagram.

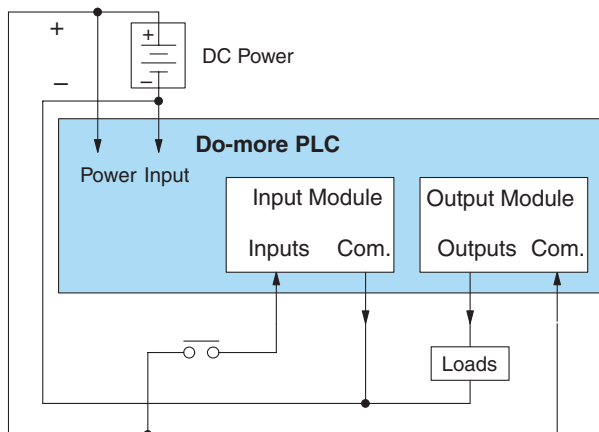

### Powering I/O Circuits Using Separate Supplies

In most applications it will be necessary to power the input devices from one power source, and to power output loads from another source. Loads often require high-energy AC power, while input sensors use low-energy DC. If a machine operator is likely to come in close contact with input wiring, then safety reasons also require isolation from high-energy output circuits. It is most convenient if the loads can use the same power source as the PLC, and the input sensors can use the auxiliary supply, as shown to the left in the figure below.

If the loads cannot be powered from the PLC supply, then a separate supply must be used as shown to the right in the figure below.

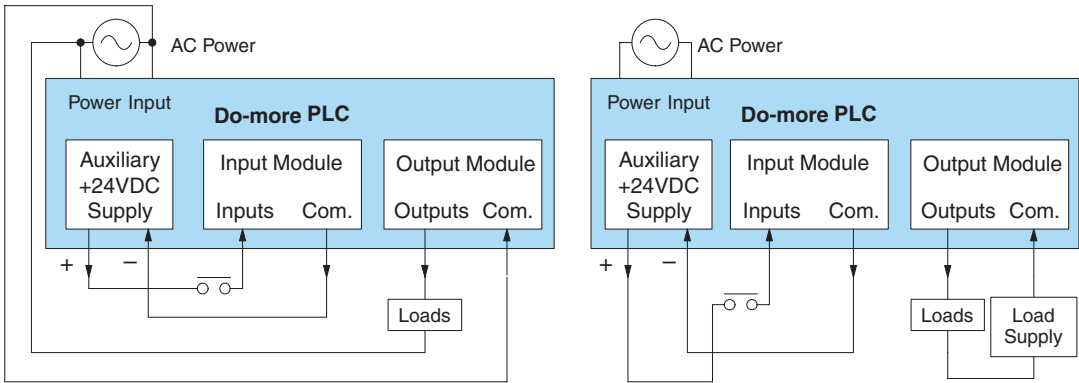

Some applications will use the PLC external power source to also power the input circuit. This typically occurs on DC-powered PLCs, as shown in the drawing below to the left. The inputs share the PLC power source supply, while the outputs have their own separate supply. A worst-case scenario, from a cost and complexity viewpoint, is an application which requires separate power sources for the PLC, input devices, and output loads. The example wiring diagram below on the right shows how this can work, but also the auxiliary supply output is an unused resource. You will want to avoid this situation if possible.

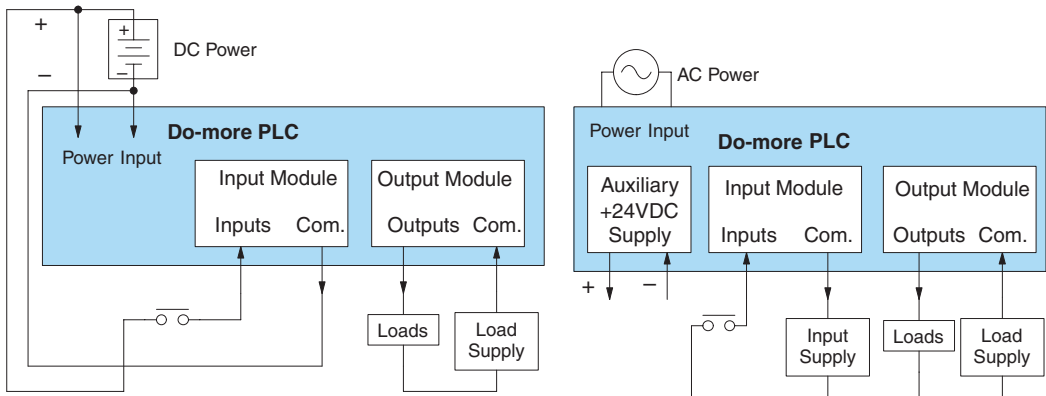

## Sinking / Sourcing Concepts

Before going further in the study of wiring strategies, you must have a solid understanding of “sinking” and “sourcing” concepts. Use of these terms occurs frequently in input or output circuit discussions. It is the goal of this section to make these concepts easy to understand, further ensuring your success in installation. First the following short definitions are provided, followed by practical applications.

**Sinking = provides a path to supply ground (-)**

**Sourcing = provides a path to supply source (+)**

First you will notice these are only associated with DC circuits and not AC, because of the reference to (+) and (-) polarities. Therefore, sinking and sourcing terminology only applies to DC input and output circuits. Input and output points that are sinking only or sourcing only can conduct current in only one direction. This means it is possible to connect the external supply and field device to the I/O point with current trying to flow in the wrong direction, and the circuit will not operate. However, you can successfully connect the supply and field device every time by understanding “sourcing” and “sinking”.

For example, the figure to the right depicts a “sinking” input. To properly connect the external supply, you will have to connect it so the input provides a path to ground (-). Start at the PLC input terminal, follow through the input sensing circuit, exit at the common terminal, and connect the supply (-) to the common terminal. By adding the switch, between the supply (+) and the input, the circuit has been completed. Current flows in the direction of the arrow when the switch is closed.

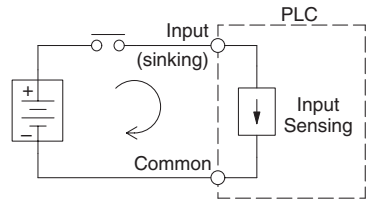

Apply the circuit principle above to the four possible combinations of input/output sinking/sourcing types as shown below. The I/O module specifications found in the “Specifications” chapters list the input or output type.

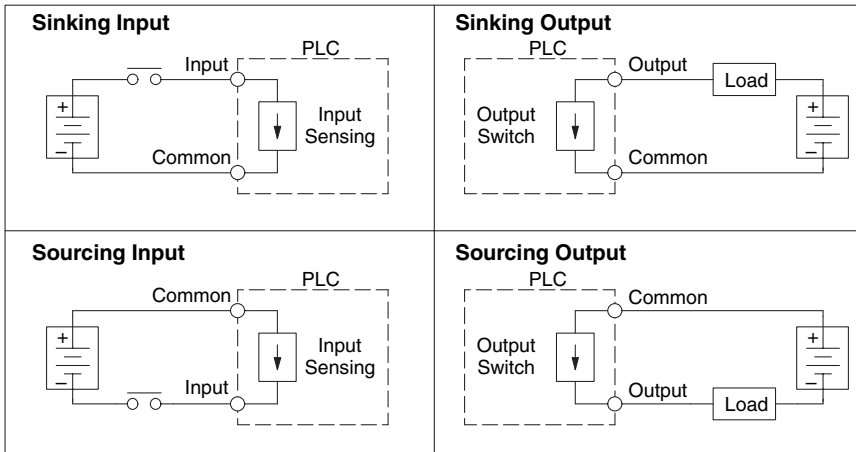

### I/O “Common” Terminal Concepts

In order for a PLC I/O circuit to operate, current must enter at one terminal and exit at another. Therefore, at least two terminals are associated with every I/O point. In the figure to the right, the Input or Output terminal is the main path for the current. An additional terminal must provide the return path to the power supply.

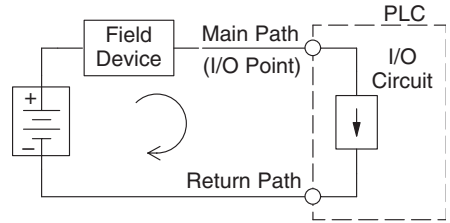

If there were unlimited space and budget for I/O terminals, every I/O point could have two dedicated terminals as the figure above shows. However, providing this level of flexibility is not practical or even necessary for most applications. So, most Input or Output points on PLCs are in groups which share the return path (called commons). The figure to the right shows a group (or bank) of four input points which share a common return path. In this way, the four inputs require only five terminals instead of eight.

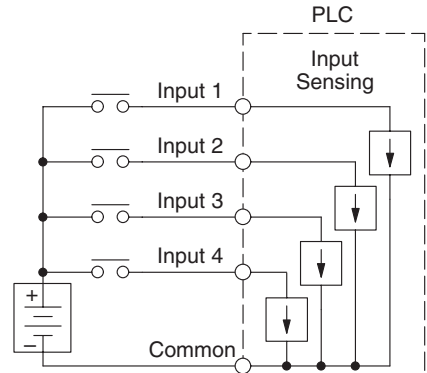

**NOTE:** In the circuit above, the current in the common path is 4 times any channel's input current when all inputs are energized. This is especially important in output circuits, where heavier gauge wire is sometimes necessary on commons.

Most Do-more input and output modules group their I/O points into banks that share a common return path. The best indication of I/O common grouping is on the wiring label, such as the one shown to the right. There are two circuit banks with eight input points in each. The common terminal for each is labeled “CA” and “CB”, respectively.

In the wiring label example, the positive terminal of a DC supply connects to the common terminals. Some symbols you will see on the wiring labels, and their meanings are:

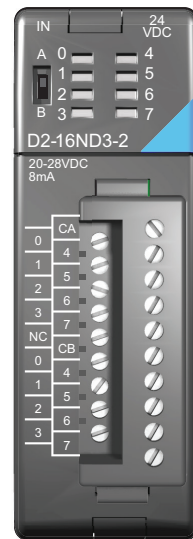
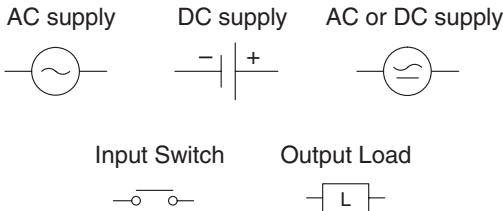

## Connecting DC I/O to “Solid State” Field Devices

In the previous section on Sourcing and Sinking concepts, the DC I/O circuits were explained to sometimes only allow current to flow one way. This is also true for many of the field devices which have solid-state (transistor) interfaces. In other words, field devices can also be sourcing or sinking.



**NOTE:** When connecting two devices in a series DC circuit, one device must be wired as sourcing and the other as sinking.

### Solid State Input Sensors

Several DC input modules are flexible because they detect current flow in either direction, so they can be wired as either sourcing or sinking. In the following circuit, a field device has an open-collector NPN transistor output. It sinks current from the PLC input point, which

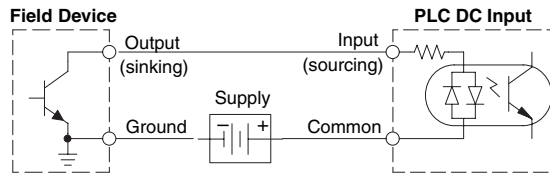

sources current. The power supply can be the +24 auxiliary supply or another supply (+12 VDC or +24VDC), as long as the input specifications are met.

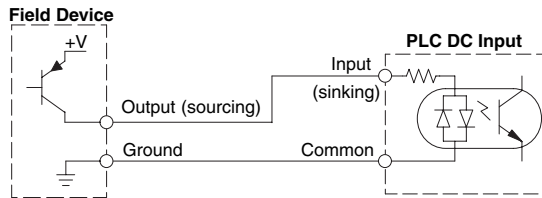

In the above circuit, a field device has an open-collector PNP transistor output. It sources current to the PLC input point, which sinks the current back to ground. Since the field device is sourcing current, no additional power supply is required.

### Solid State Output Loads

Sometimes an application requires connecting a PLC output point to a solid state input on a device. This type of connection is usually made to carry a low-level control signal, not to send DC power to an actuator.

Several of the Do-more DC output modules are the sinking type. This means that each DC output provides a path to ground when it is energized. In the following circuit, the PLC output point sinks current to the output common when energized. It is connected to a sourcing input of a field device input.

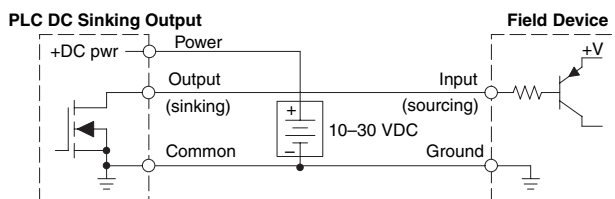

In the next example a PLC sinking DC output point is connected to the sinking input of a field device. This is a little tricky, because both the PLC output and field device input are sinking type. Since the circuit must have one sourcing and one sinking device, a sourcing capability needs to be added to the PLC output by using a pull-up resistor. In the circuit below, a  $R_{pull-up}$  is connected from the output to the DC output circuit power input.

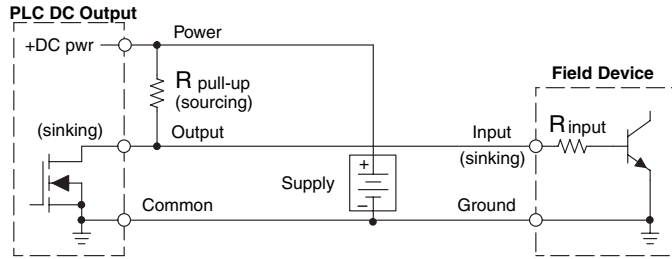

**NOTE :** DO NOT attempt to drive a heavy load (>25mA) with this pull-up method

**NOTE :** Using the pull-up resistor to implement a sourcing output has the effect of inverting the output point logic. In other words, the field device input is energized when the PLC output is OFF, from a ladder logic point of view. Your ladder program must comprehend this and generate an inverted output. Or, you may choose to cancel the effect of the inversion elsewhere, such as in the field device.

It is important to choose the correct value of  $R_{pull-up}$ . In order to do so, you need to know the nominal input current to the field device ( $I_{input}$ ) when the input is energized. If this value is not known, it can be calculated as shown (a typical value is 15mA). Then use  $I_{input}$  and the voltage of the external supply to compute  $R_{pull-up}$ . Then calculate the power  $P_{pull-up}$  (in watts), in order to size  $R_{pull-up}$  properly.

$$I_{input} = \frac{V_{input(turn-on)}}{R_{input}}$$

$$R_{pull-up} = \frac{V_{supply} - 0.7}{I_{input}} - R_{input}$$

$$P_{pull-up} = \frac{V_{supply}^2}{R_{pullup}}$$

Of course, the easiest way to drive a sinking input field device is to use a DC sourcing output module as shown below. The Darlington NPN stage will have about 1.5 V ON-state saturation, but this is not a problem with low-current solid-state loads.

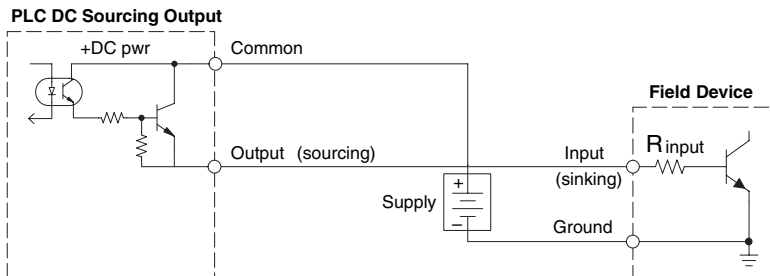



## Relay Output Guidelines

Several output modules in the Do-more I/O family feature relay outputs: D2-04TRS, D2-08TR, D2-12TR, D2-08CDR, F2-08TR and F2-08TRS. Relays are best for the following applications:

- Loads that require higher currents than the solid-state outputs can deliver
- Cost-sensitive applications
- Some output channels need isolation from other outputs (such as when some loads require different voltages than other loads)

Some applications in which NOT to use relays:

- Loads that require currents under 10mA
- Loads which must be switched at high speed or heavy duty cycle

Relay outputs in the Do-more output modules are available in two contact arrangements, shown to the right. The Form A type, or SPST (single pole, single throw) type, is normally open and is the simplest to use. The Form C type, or SPDT (single pole, double throw) type, has a center contact which moves and a stationary contact on either side. This provides a normally closed contact and a normally open contact.

Some relay output module's relays share common terminals, which connect to the wiper contact in each relay of the bank. Other relay modules have relays which are completely isolated from each other. In all cases, the module drives the relay coil when the corresponding output point is on.

**Relay with Form A contacts**

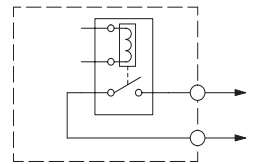

**Relay with Form C contacts**

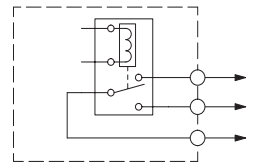

## Relay Outputs – Transient Suppression for Inductive Loads in a Control System

The following pages are intended to give a quick overview of the negative effects of transient voltages on a control system and provide some simple advice on how to effectively minimize them. The need for transient suppression is often not apparent to the newcomers in the automation world. Many mysterious errors that can afflict an installation can be traced back to a lack of transient suppression.

### What is a Transient Voltage and Why is it Bad?

Inductive loads (devices with a coil) generate transient voltages as they transition from being energized to being de-energized. If not suppressed, the transient can be many times greater than the voltage applied to the coil. These transient voltages can damage PLC outputs or other electronic devices connected to the circuit, and cause unreliable operation of other electronics in the general area. Transients must be managed with suppressors for long component life and reliable operation of the control system.

This example shows a simple circuit with a small 24V/125mA/3W relay. As you can see, when the switch is opened, thereby de-energizing the coil, the transient voltage generated across the switch contacts peaks at 140V!

#### Example: Circuit with no Suppression

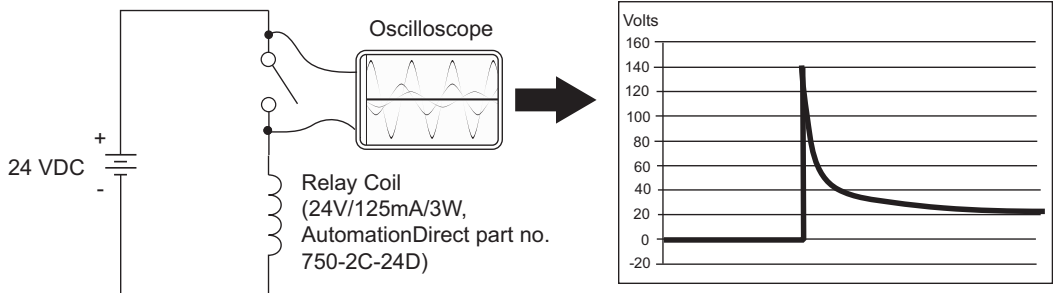

In the same circuit, replacing the relay with a larger 24V/290mA/7W relay will generate a transient voltage exceeding 800V (not shown). Transient voltages like this can cause many problems, including:

- Relay contacts driving the coil may experience arcing, which can pit the contacts and reduce the relay's lifespan.
- Solid state (transistor) outputs driving the coil can be damaged if the transient voltage exceeds the transistor's ratings. In extreme cases, complete failure of the output can occur the very first time a coil is de-energized.
- Input circuits, which might be connected to monitor the coil or the output driver, can also be damaged by the transient voltage.

A very destructive side-effect of the arcing across relay contacts is the electromagnetic interference (EMI) it can cause. This occurs because the arcing causes a current surge, which releases RF energy. The entire length of wire between the relay contacts, the coil, and the power source carries the current surge and becomes an antenna that radiates the RF energy. It will readily couple into parallel wiring and may disrupt the PLC and other electronics in the area. This EMI can make an otherwise stable control system behave unpredictably at times.

### PLC's Integrated Transient Suppressors

Although the PLC's outputs typically have integrated suppressors to protect against transients, they are not capable of handling them all. It is usually necessary to have some additional transient suppression for an inductive load.

Here is another example using the same 24V/125mA/3W relay used earlier. This example measures the PNP transistor output of a D0-06DD2 PLC, which incorporates an integrated Zener diode for transient suppression. Instead of the 140V peak in the first example, the transient voltage here is limited to about 40V by the Zener diode. While the PLC will probably tolerate repeated transients in this range for some time, the 40V is still beyond the module's peak output voltage rating of 30V.

#### Example: Small Inductive Load with Only Integrated Suppression

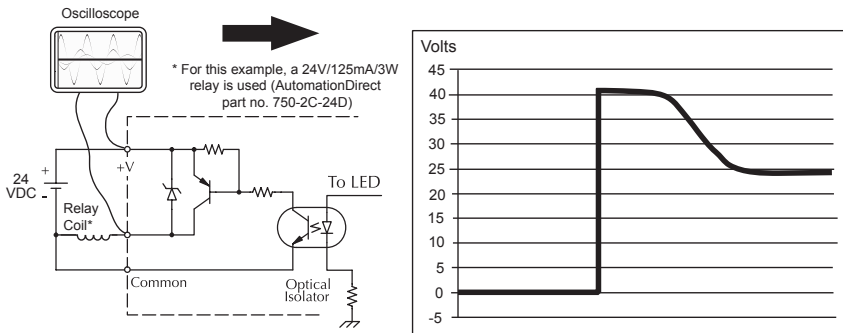

The next example uses the same circuit as above, but with a larger 24V/290mA/7W relay, thereby creating a larger inductive load. As you can see, the transient voltage generated is much worse, peaking at over 50V. Driving an inductive load of this size without additional transient suppression is very likely to permanently damage the PLC output.

#### Example: Larger Inductive Load with Only Integrated Suppression

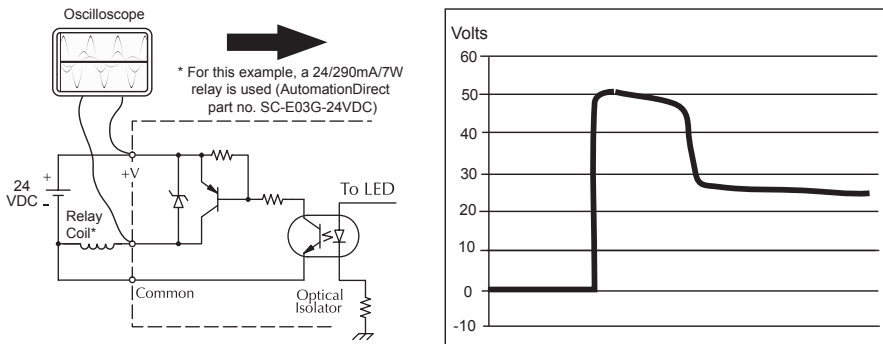

Additional transient suppression should be used in both these examples. If you are unable to measure the transients generated by the connected loads of your control system, using additional transient suppression on all inductive loads would be the safest practice.

## Types of Additional Transient Protection

### DC Coils:

The most effective protection against transients from a DC coil is a flyback diode. A flyback diode can reduce the transient to roughly 1V over the supply voltage, as shown in this example.

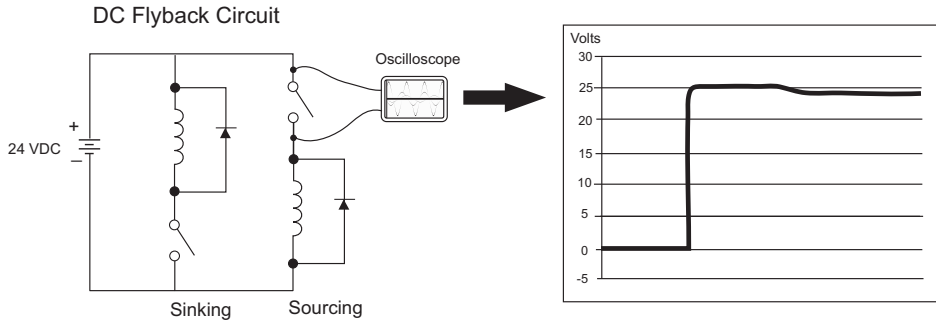

Many AutomationDirect socketed relays and motor starters have add-on flyback diodes that plug or screw into the base, such as the AD-ASMD-250 protection diode module and 784-4C-SKT-1 socket module shown below. If an add-on flyback diode is not available for your inductive load, an easy way to add one is to use AutomationDirect's DN-D10DR-A diode terminal block, a 600VDC power diode mounted in a slim DIN rail housing.



**AD-ASMD-250**  
Protection Diode Module



**784-4C-SKT-1**  
Relay Socket

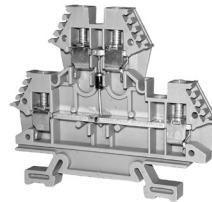

**DN-D10DR-A**  
Diode Terminal Block

Two more common options for DC coils are Metal Oxide Varistors (MOV) or TVS diodes. These devices should be connected across the driver (PLC output) for best protection as shown below. The optimum voltage rating for the suppressor is the lowest rated voltage available that will NOT conduct at the supply voltage, while allowing a safe margin.

AutomationDirect's ZL-TSD8-24 transorb module is a good choice for 24VDC circuits. It is a bank of 8 uni-directional 30V TVS diodes. Since they are uni-directional, be sure to observe the polarity during installation. MOVs or bi-directional TVS diodes would install at the same location, but have no polarity concerns.



**ZL-TSD8-24**  
Transorb Module

DC MOV or TVS Diode Circuit

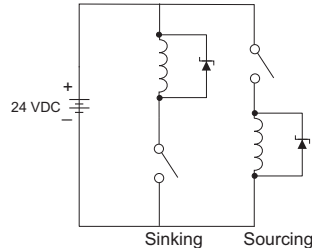

### AC Coils:

Two options for AC coils are MOVs or bi-directional TVS diodes. These devices are most effective at protecting the driver from a transient voltage when connected across the driver (PLC output) but are also commonly connected across the coil. The optimum voltage rating for the suppressor is the lowest rated voltage available that will NOT conduct at the supply voltage, while allowing a safe margin.

AutomationDirect's ZL-TSD8-120 transorb module is a good choice for 120VAC circuits. It is a bank of eight bi-directional 180V TVS diodes.



**ZL-TSD8-120**  
Transorb Module

AC MOV or Bi-Directional Diode Circuit

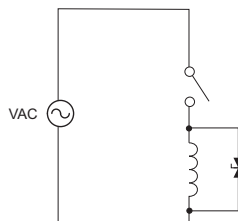

**NOTE:** Manufacturers of devices with coils frequently offer MOV or TVS diode suppressors as an add-on option which mount conveniently across the coil. Before using them, carefully check the suppressor ratings. Just because the suppressor is made specifically for that part does not mean it will reduce the transient voltages to an acceptable level.

For example, a MOV or TVS diode rated for use on 24–48 VDC coils would need to have a high enough voltage rating to NOT conduct at 48V. That suppressor might typically start conducting at roughly 60VDC. If it were mounted across a 24V coil, transients of roughly 84V (if sinking output) or -60V (if sourcing output) could reach the PLC output. Many semiconductor PLC outputs cannot tolerate such levels.

Notes: