

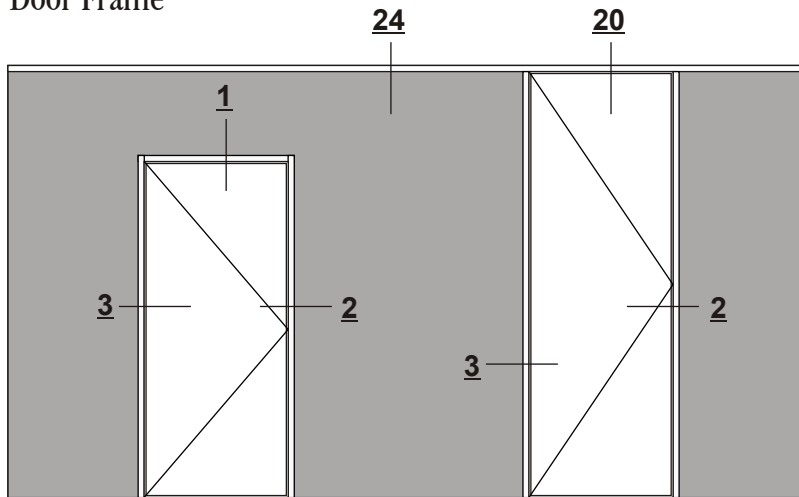

Classic

CLASSIC Reference Drawings

Door Frame



Door Frame with Sidelight

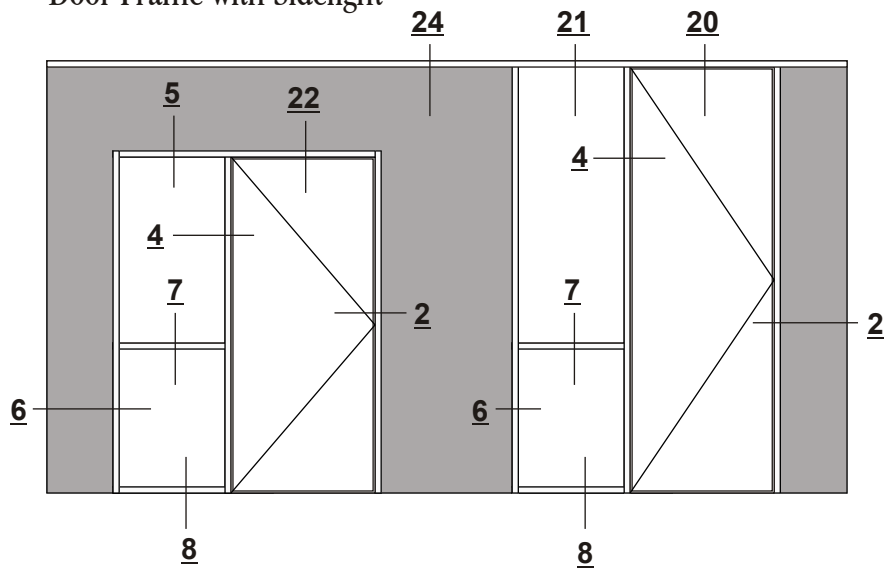

See reference matrix pages for typical details information.

CLASSIC Reference Drawings

Door Frame with Partial Height Sidelight

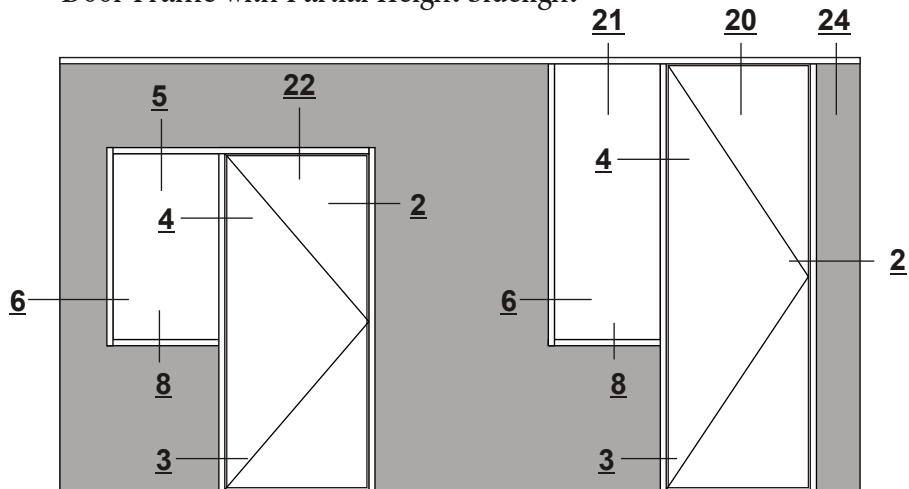

Door Frame with Transom

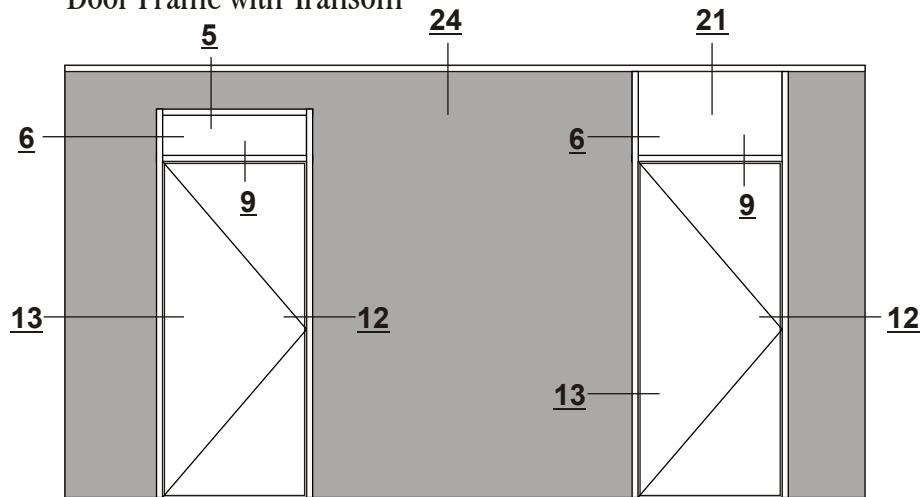

See reference matrix pages for typical details information.

CLASSIC Reference Drawings

Door Frame with Sidelight and Transom

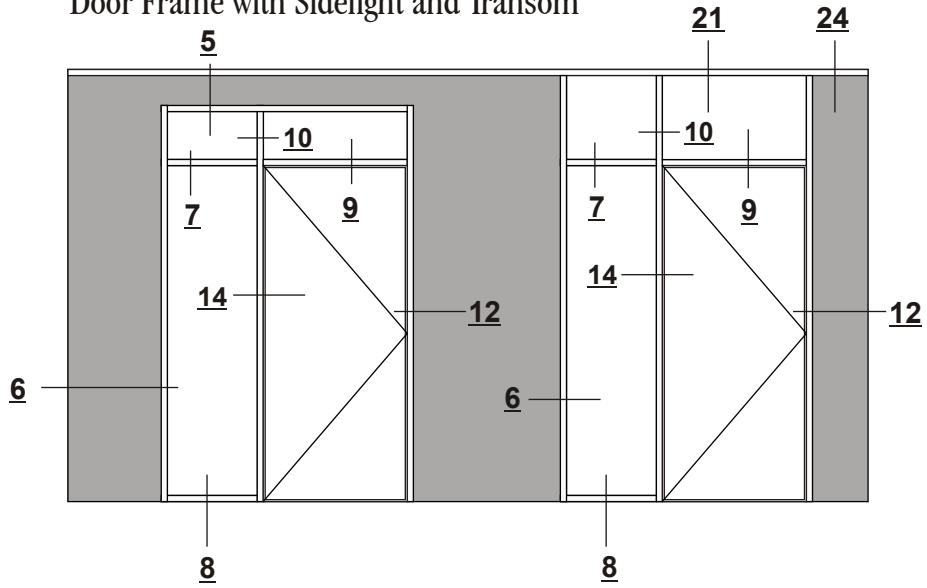

Borrowed Light

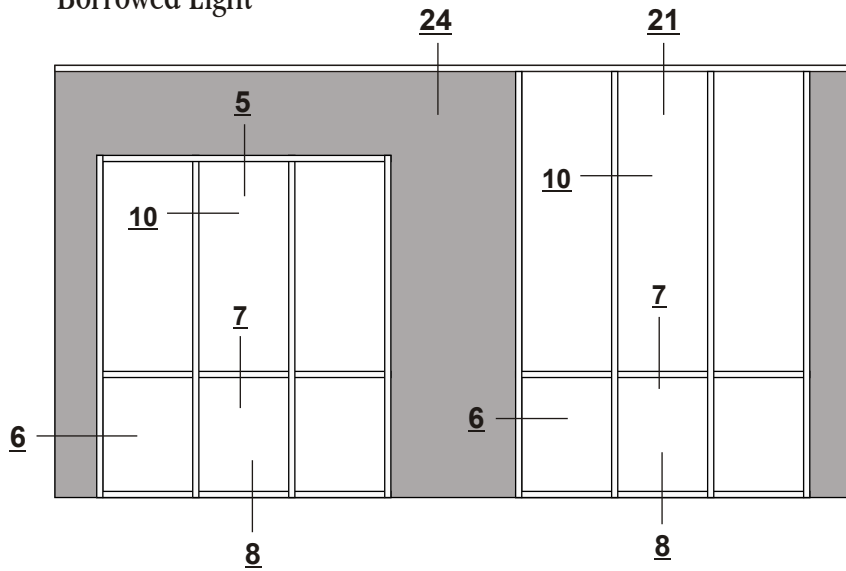

See reference matrix pages for typical details information.

CLASSIC Reference Drawings

Partial Height Borrowed Light

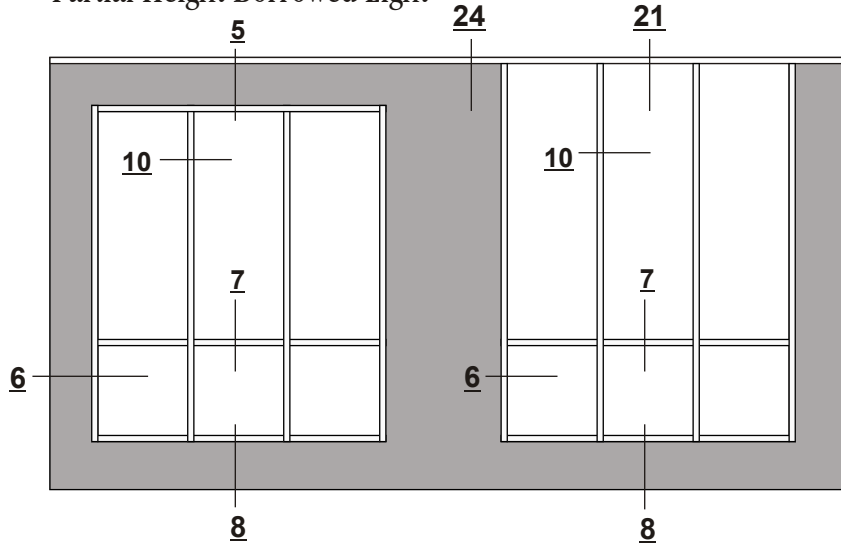

Cased Opening

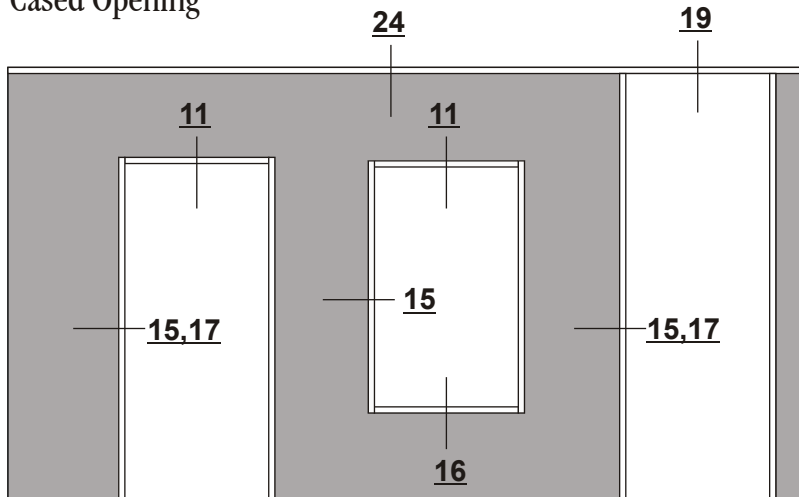

See reference matrix pages for typical details information.

CLASSIC Reference Drawings

Corners

See reference matrix pages for typical details information.

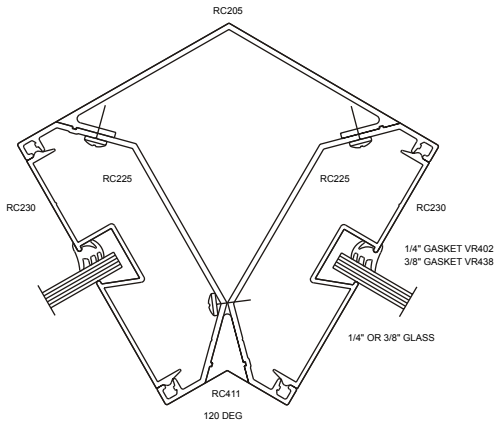

26

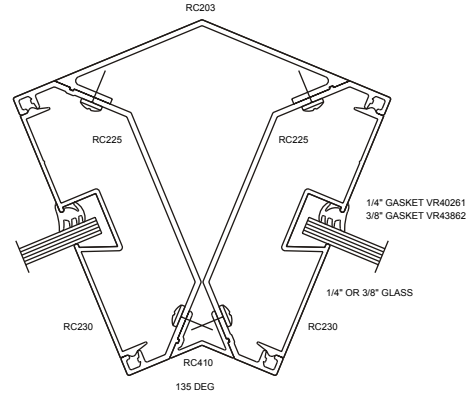

27

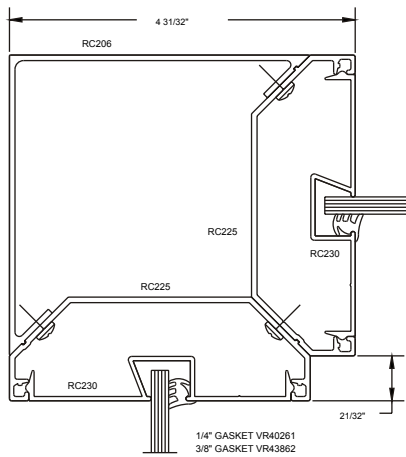

28

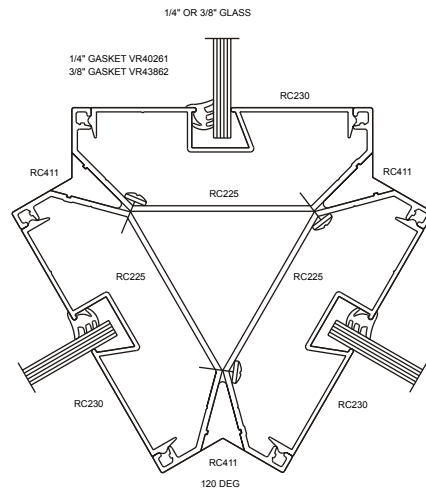

29

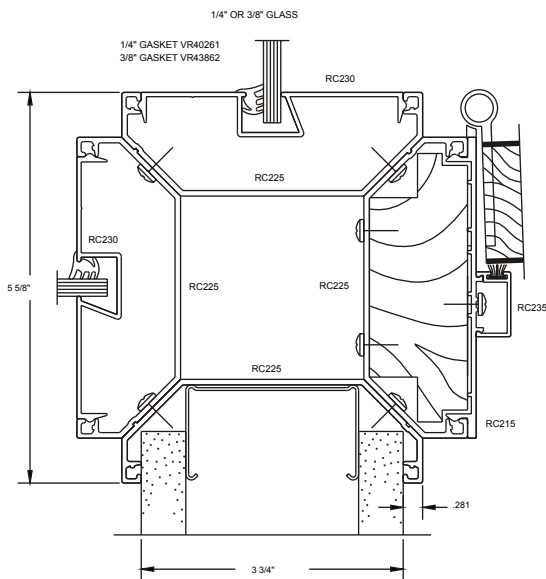

30

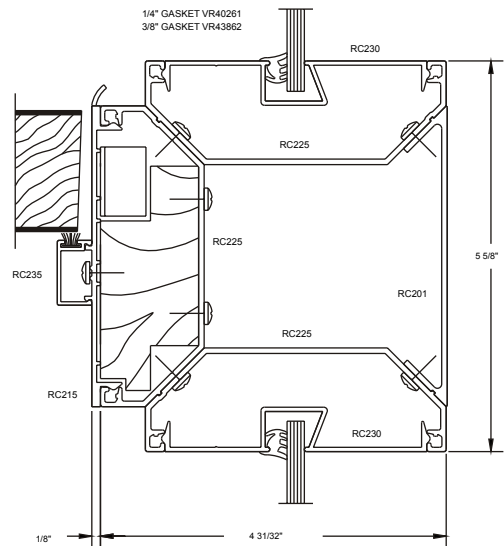

31

CLASSIC Reference Drawings

Corners

See reference matrix pages for typical details information.

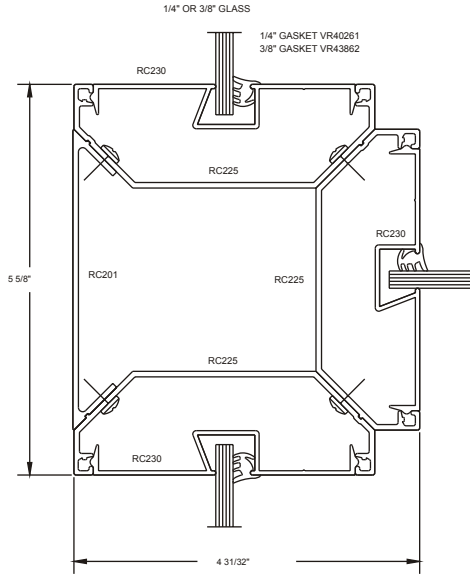

32

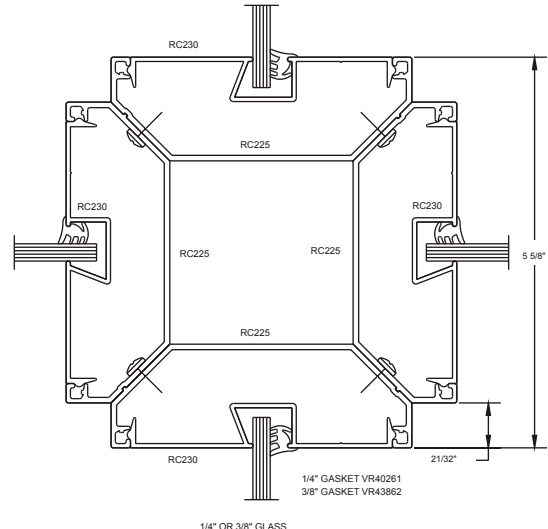

33

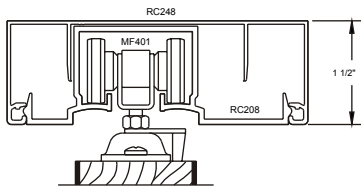

34

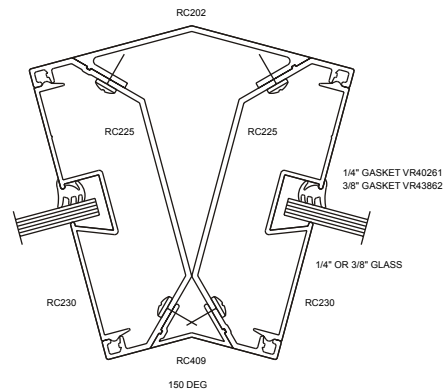

35

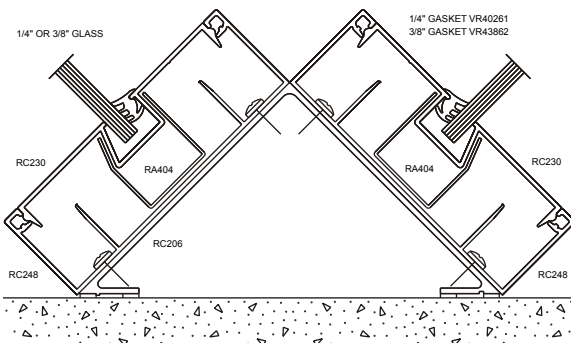

36

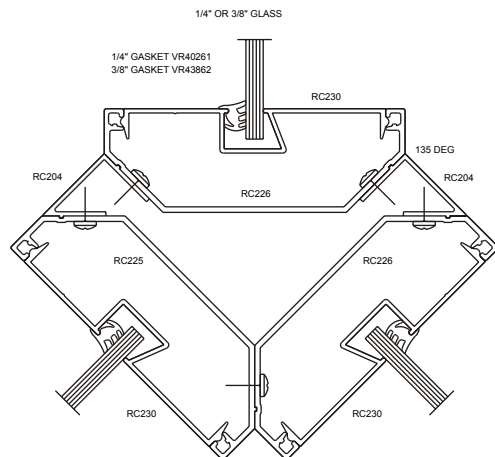

37

CLASSIC Reference Drawings

Corners

See reference matrix pages for typical details information.

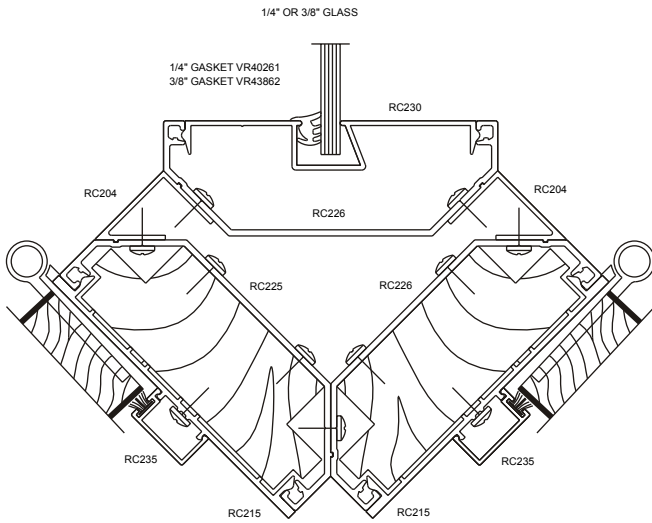

38

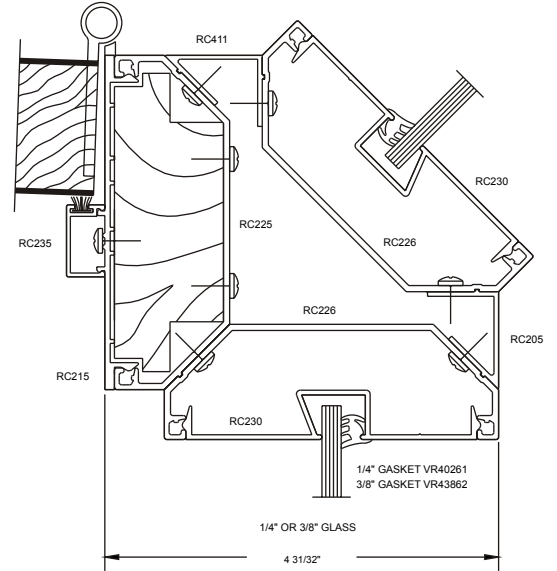

39

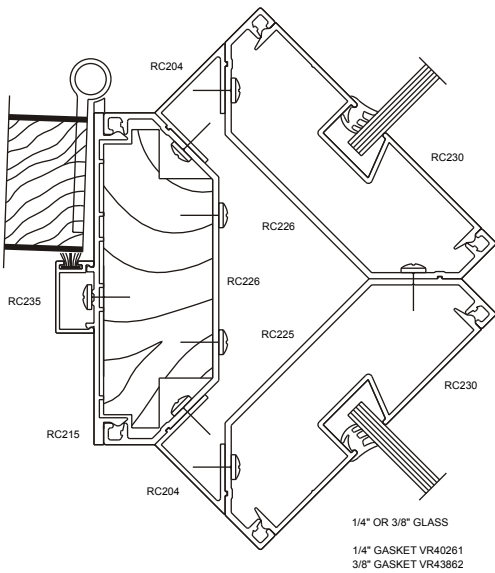

40

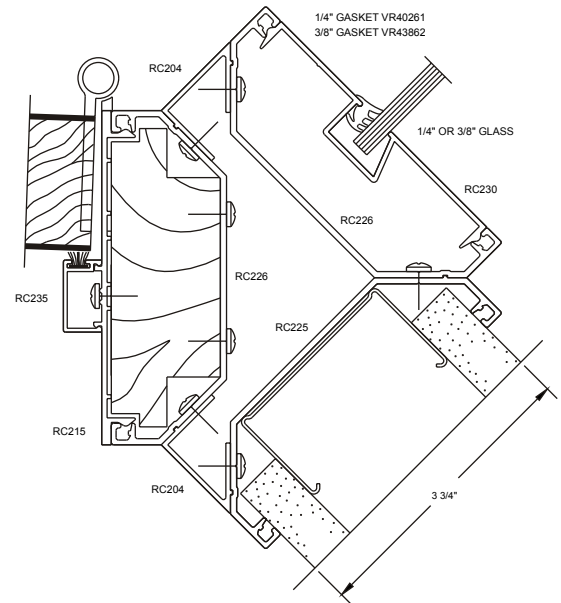

41

CLASSIC Reference Drawings

Specialty Frames

See reference matrix pages for typical details information.

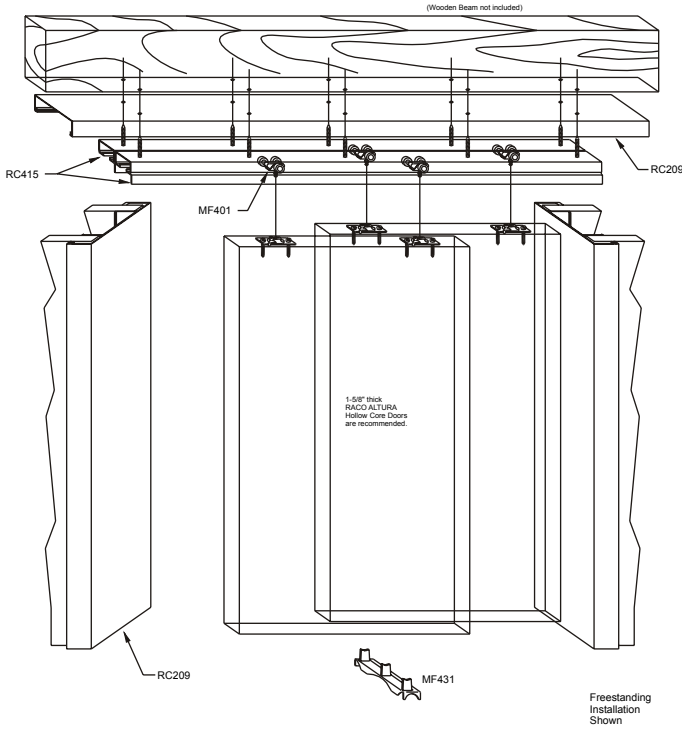

42

By-Passing Door

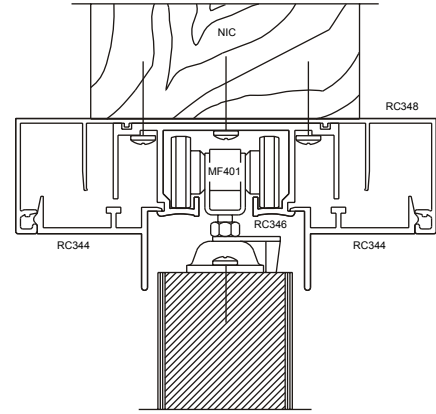

43

Pocket Door

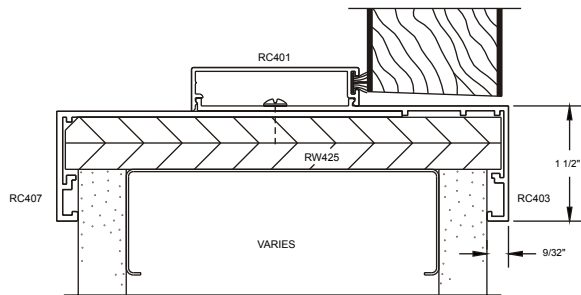

44

Adjustable 20-min. Frame

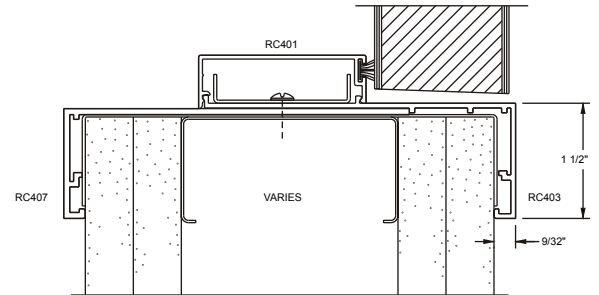

45

Adjustable 90-min. Frame

RACO Interior OfficeFronts™

CLASSIC Reference Matrix

Elevation Number	SERIES 225	SERIES 375	SERIES 487
1	C1-034	C2-022, C2-024, C2-025	C3-028, C3-029, C3-032
2	C1-018	C2-033, C2-034	C3-042, C3-043
3	C1-029	C2-056	C3-057
4	C1-017, C1-028	C2-035, C2-057, C2-058	C3-044, C3-058
5		C2-040, C2-041, C2-043	C3-040, C3-041
6	C1-019, C1-025	C2-038, C2-044, C2-045, C2-052, C2-055, C2-061	C3-036, C3-049
7	C1-022	C2-036, C2-046	C3-045
8	C1-026, C1-027	C2-048, C2-053, C2-054	C3-055, C3-056
9	C1-030	C2-059	C3-031
10	C1-020, C1-031	C2-028, C2-049, C2-051	C3-046, C3-059
11	C1-035	C2-016	C3-047
12	C1-021	C2-039	C3-050
13	C1-021 SIM.	C2-039 SIM.	C3-050 SIM.
14	C1-023, C1-024	C2-037	C3-048
15	C1-009	C2-018	C3-025
16	C1-011	C2-018 SIM., C2-016	
17	C1-012	C2-019	C3-027
18			C3-035
19	C1-010	C2-017	C3-026
20	C1-013	C2-021	C3-030
21	C1-014	C2-027, C2-032, C2-047	C3-035
22	C1-033	C2-023, C2-026, C2-042	C3-033, C3-034
23			
24	C1-032	C2-029	C3-037
25		C2-050	C3-053
26	C1-001	C2-002	C3-002
27	C1-002	C2-003	C3-003
28	C1-003	C2-001	C3-001
29	C1-004	C2-007	C3-011
30	C1-005	C2-015	C3-014
31	C1-006	C2-012	C3-012
32	C1-007	C2-006	C3-010
33	C1-008	C2-014	C3-013, C3-020, C3-022 C3-039
34	C1-015	C2-030	C3-019
35		C2-004	C3-004
36		C2-005	C3-005
37		C2-008	
38		C2-009	
39		C2-010	
40		C2-011	
41		C2-013	
42		C2-031	C3-023, C3-024, C3-038
43			C3-021, C3-051, C3-052
44			C3-006, C3-007, C3-008 C3-009, C3-018
45			C3-015, C3-016, C3-017

See reference elevation pages for typical details information.

CLASSIC Typical Details

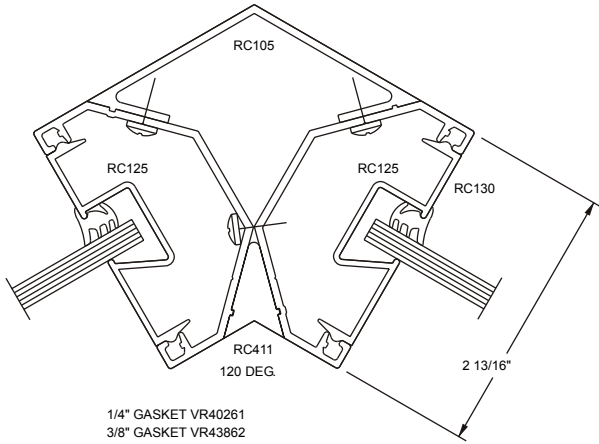

C1-001_225_2_way_corner_120_deg.dxf

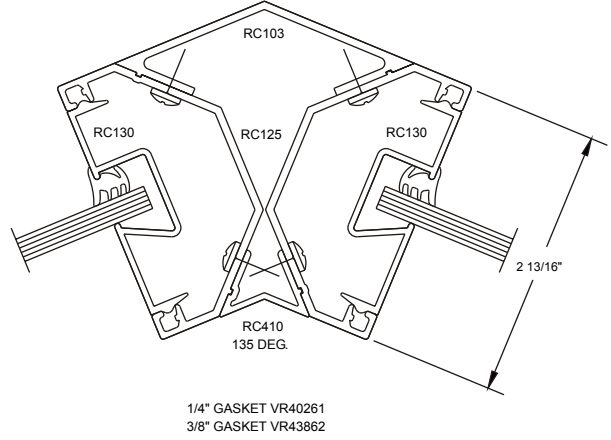

C1-002_225_2_way_corner_135_deg.dxf

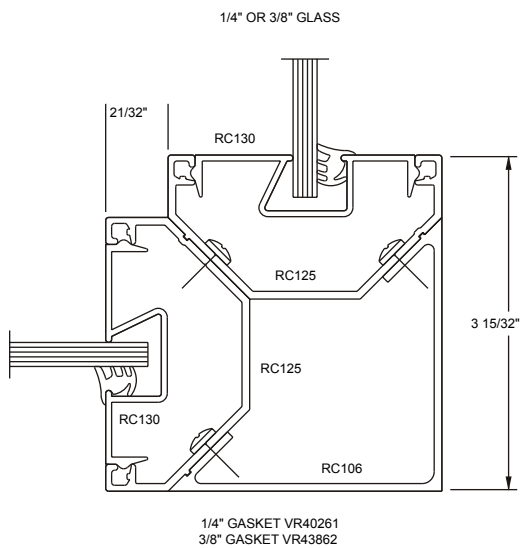

C1-003_225_2_way_corner.dxf

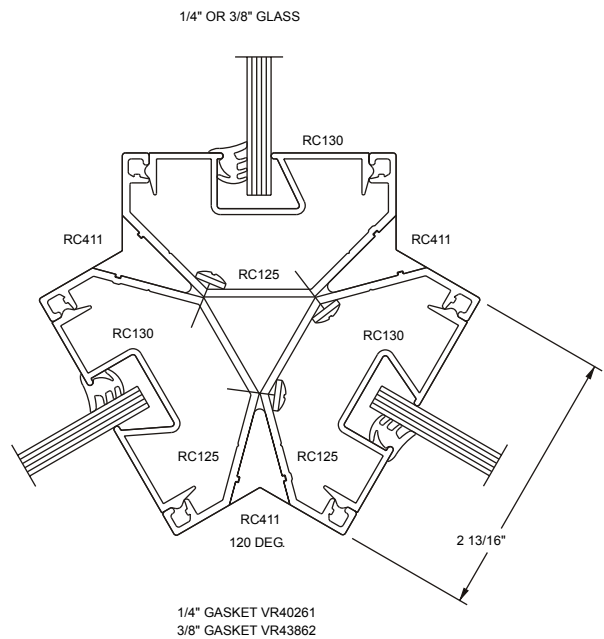

C1-004_225_3_way_corner_120_deg.dxf

CLASSIC Typical Details

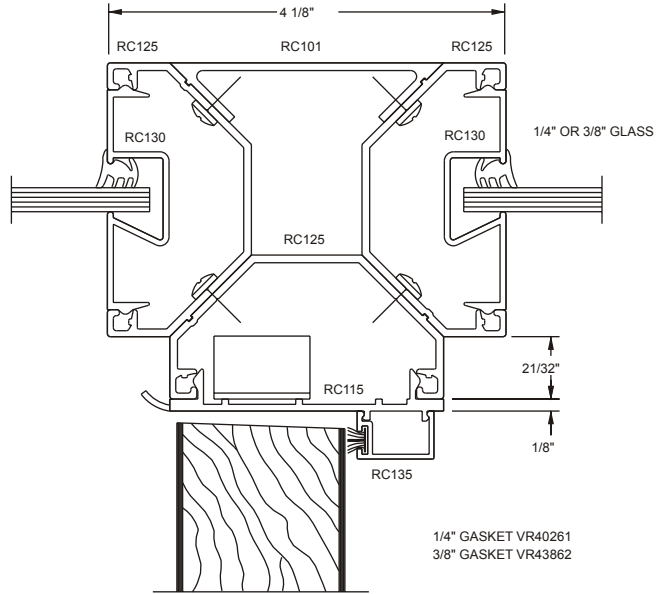
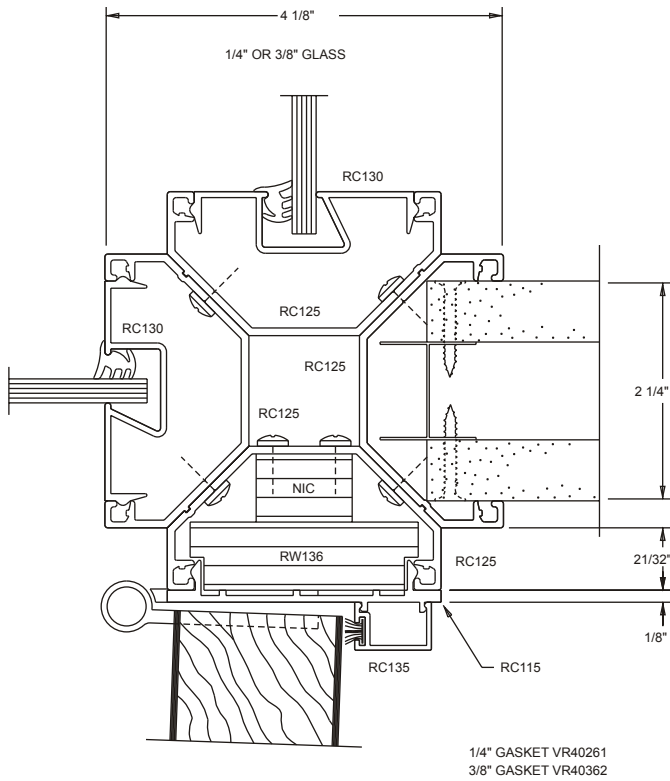

C1-006_225_3_way_corner_2_way_glazing_and_strike_jamb.dxf

C1-005_225_3_way_corner_2_way_glazing_and_hinge_jamb.dxf

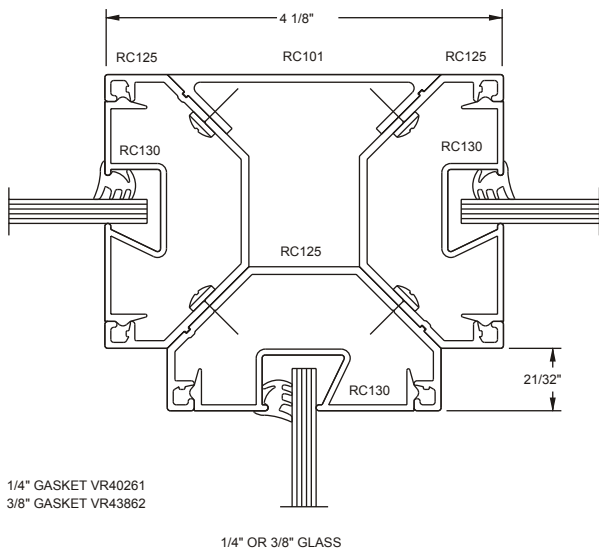

C1-007_225_3_way_corner.dxf

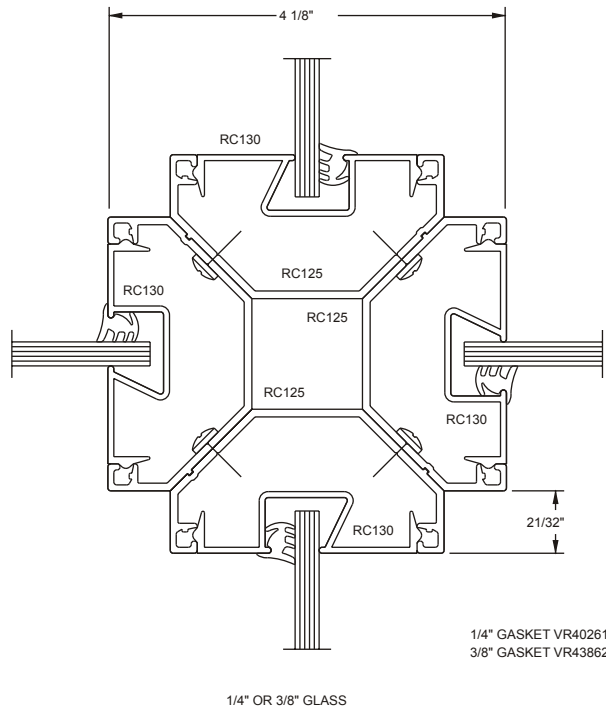

C1-008_225_4_way_corner.dxf

CLASSIC Typical Details

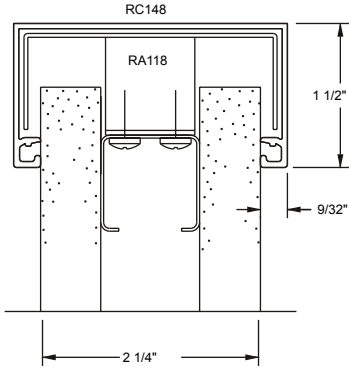

C1-009_225_cased_jamb.dxf

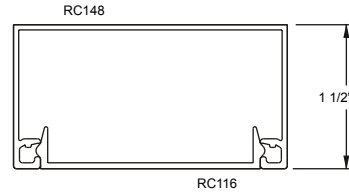

C1-010_225_cased_opening_header.dxf

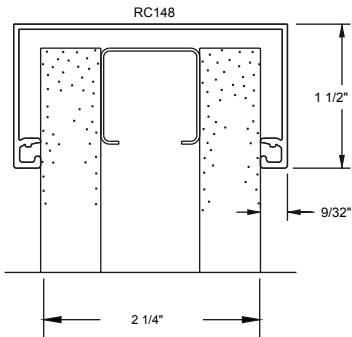

C1-011_225_cased_sill_partial_height.dxf

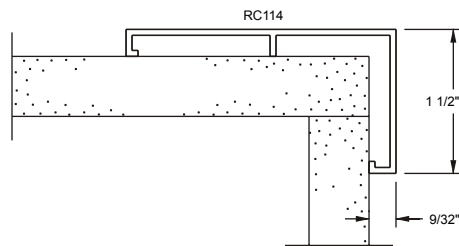

C1-012_225_closet_jamb.dxf

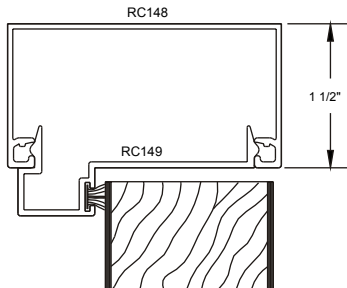

C1-013_225_door_head_at_head_track.dxf

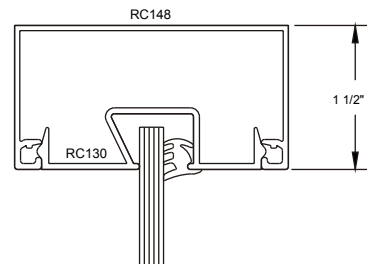

1/4" OR 3/8" GLASS

1/4" GASKET VR40261
3/8" GASKET VR43862

C1-014_225_head_track_glazing_insert.dxf

CLASSIC Typical Details

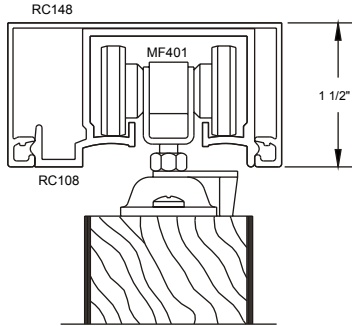

C1-015_225_head_at_single_bifold_door.dxf

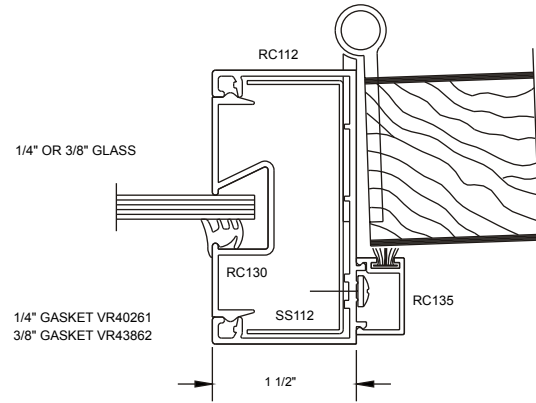

C1-017_225_hinge_jamb_at_glass.dxf
See also C1-028

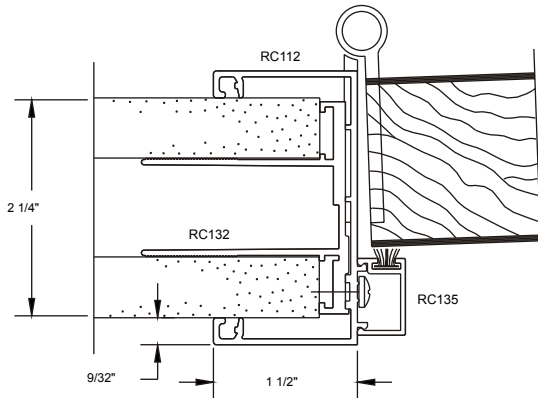

C1-018_225_hinge_jamb_left_hand.dxf

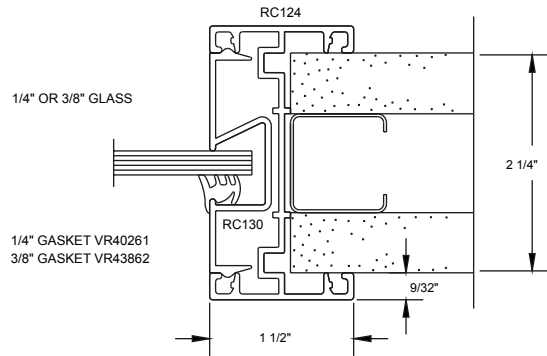

C1-019_225_vertical_mullion_at_glazing.dxf
See also C1-025

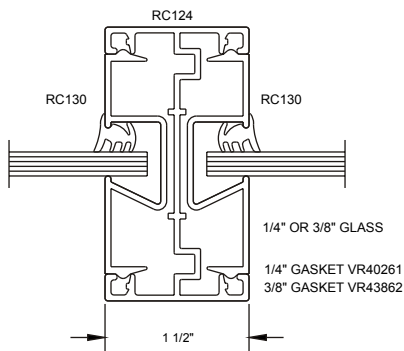

C1-020_225_vertical_mullion_glazing_both_sides.dxf
See also C1-031

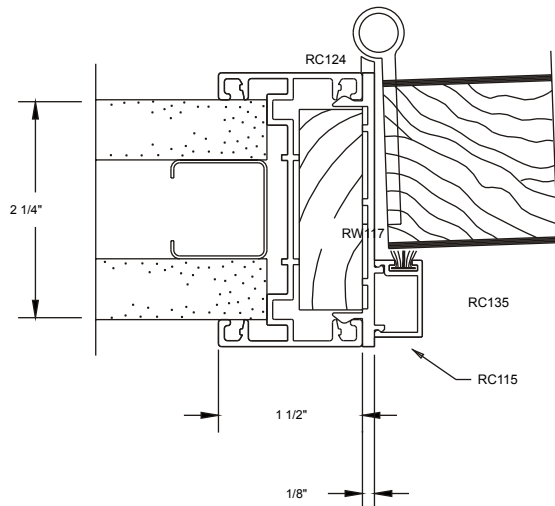

C1-021_225_vertical_mullion_hinge_door_jamb.dxf

CLASSIC Typical Details

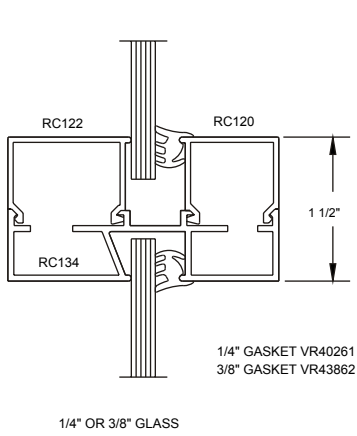

C1-022_225_horizontal_mullion.dxf

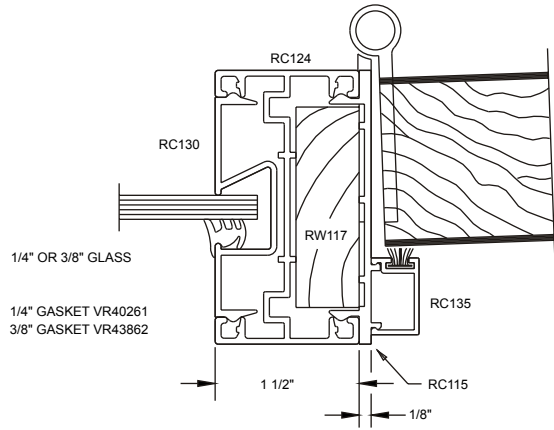

C1-023_225_vert_mullion_with_hinge_jamb_at_glass.dxf
See also C1-024

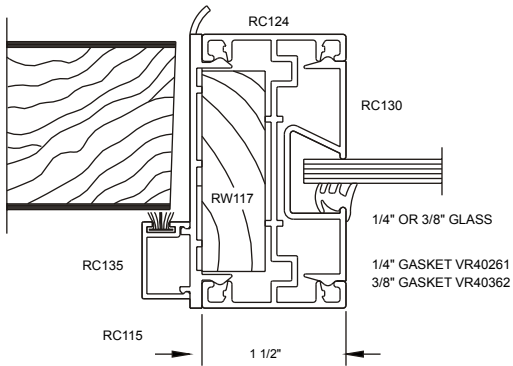

C1-024_225_vert_mullion_with_strike_jamb_at_glass.dxf
See also C1-023

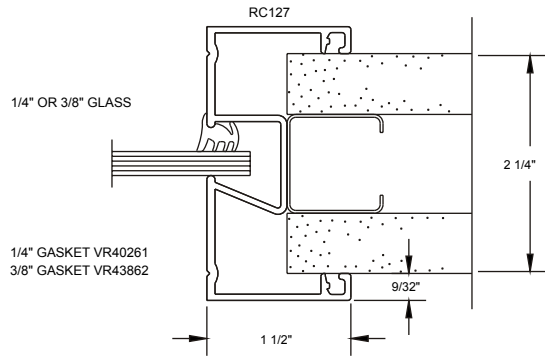

C1-025_225_jamb.dxf
See also C1-019

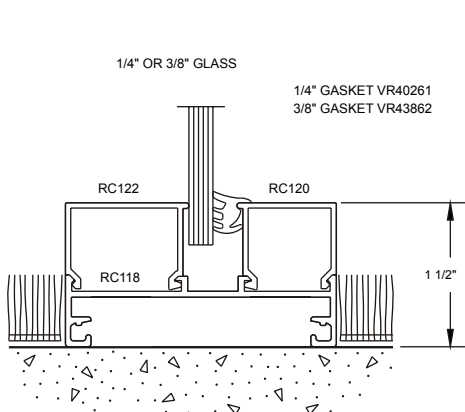

C1-026_225_sill_full_height.dxf
See also C1-027

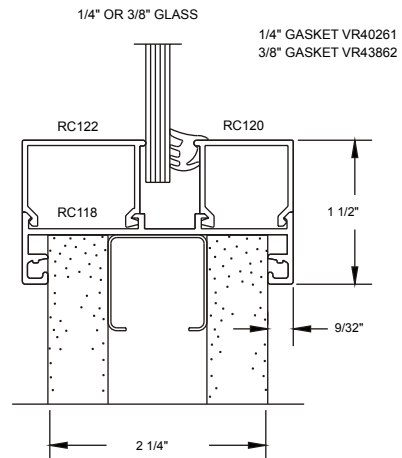

C1-027_225_sill_partial_height.dxf
See also C1-026

CLASSIC Typical Details

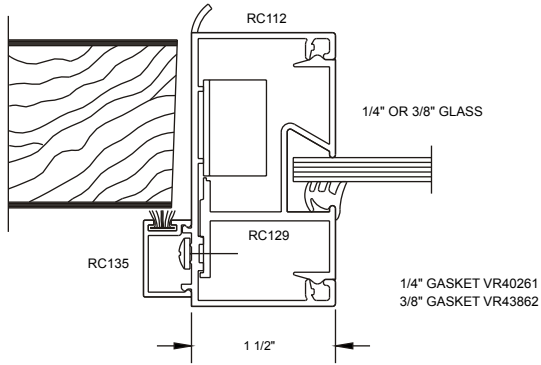

C1-028_225_strike_jamb_door_frame_at_glass.dxf
See also C1-017

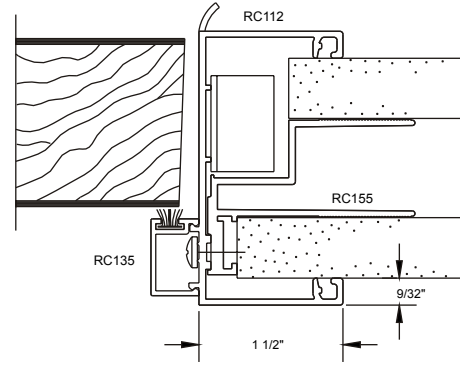

C1-029_225_strike_jamb_right_hand.dxf

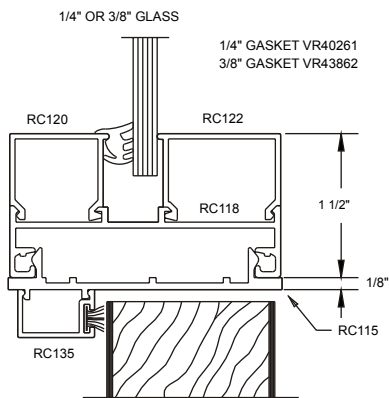

C1-030_225_transom_bar.dxf

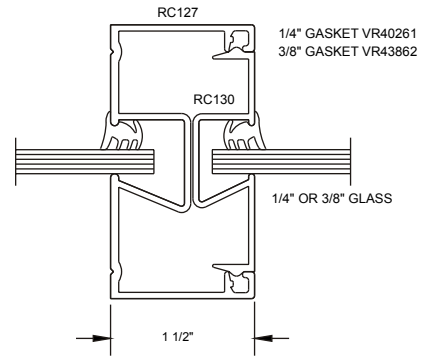

C1-031_225_vertical_mullion.dxf
See also C1-020

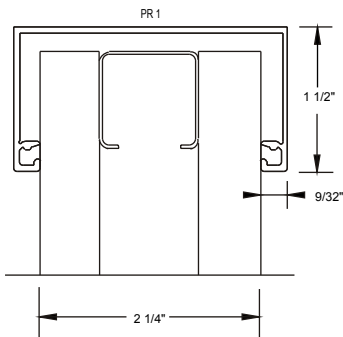

C1-032_225_head_track_to_drywall.dxf

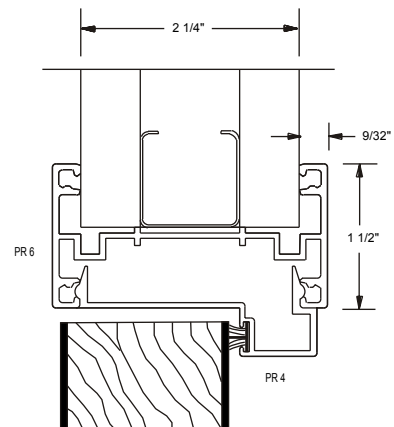

C1-033_225_door_frame_head_in_H_channel_to_drywall.dxf

CLASSIC Typical Details

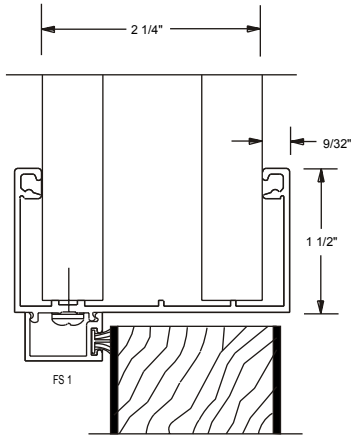

C1-034_225_door_frame_head_to_drywall.dxf

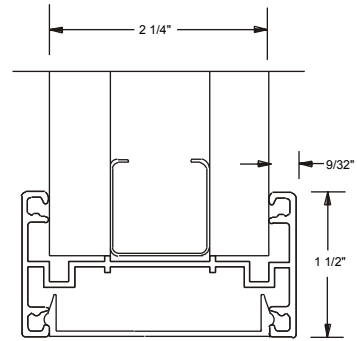

C1-035_225_cased_head_in_H_channel_to_drywall.dxf

CLASSIC Typical Details

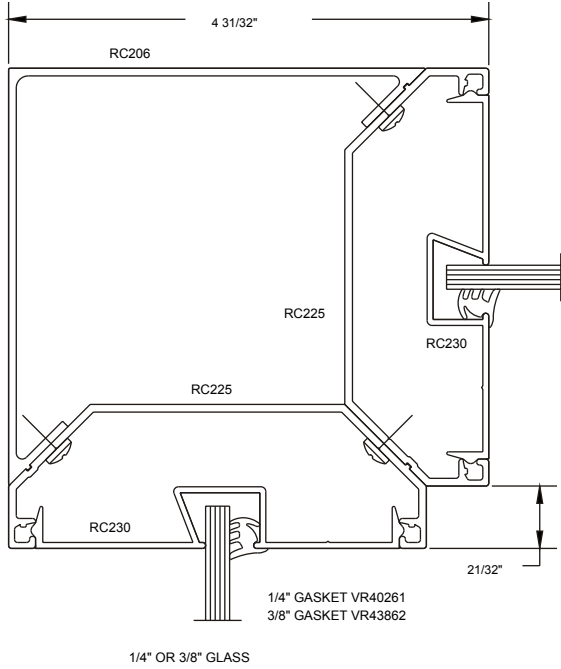

C2-001_375_2_way_corner.dxf

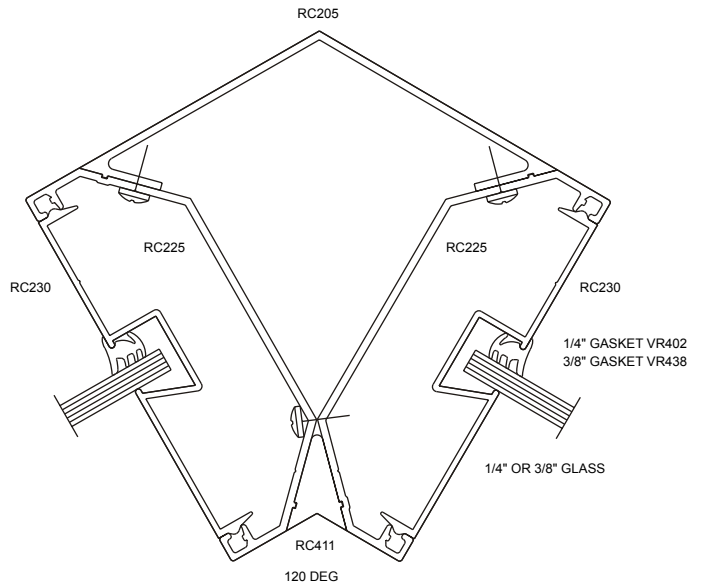

C2-002_375_2_way_corner_120_deg.dxf

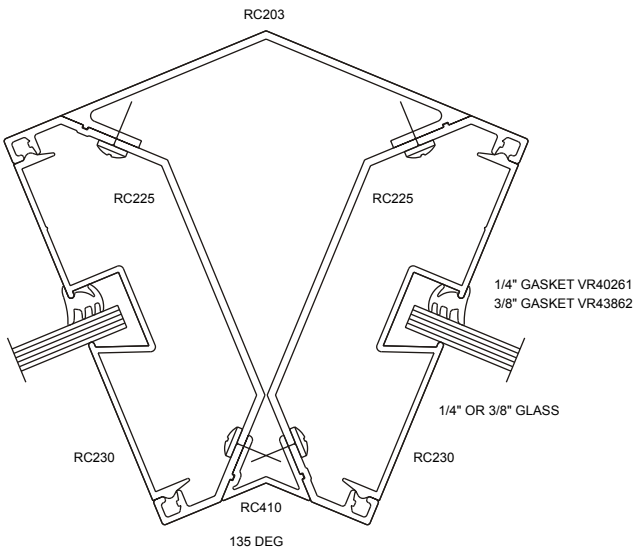

C2-003_375_2_way_corner_135_deg.dxf

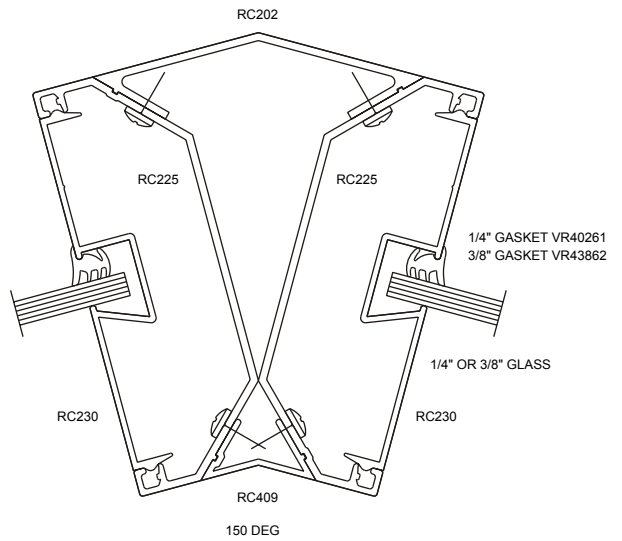

C2-004_375_2_way_corner_150_deg.dxf

CLASSIC Typical Details

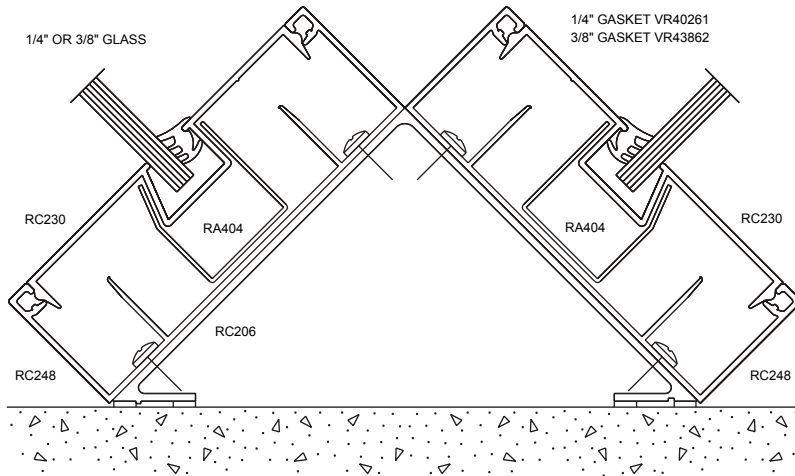

C2-005_375_2_way_corner_to_masonry.dxf

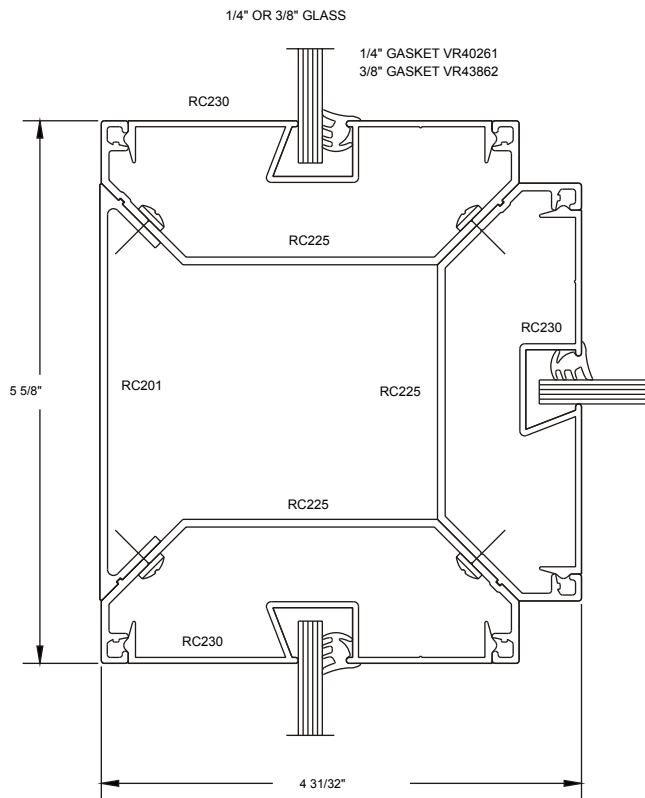

C2-006_375_3_way_corner.dxf

CLASSIC Typical Details

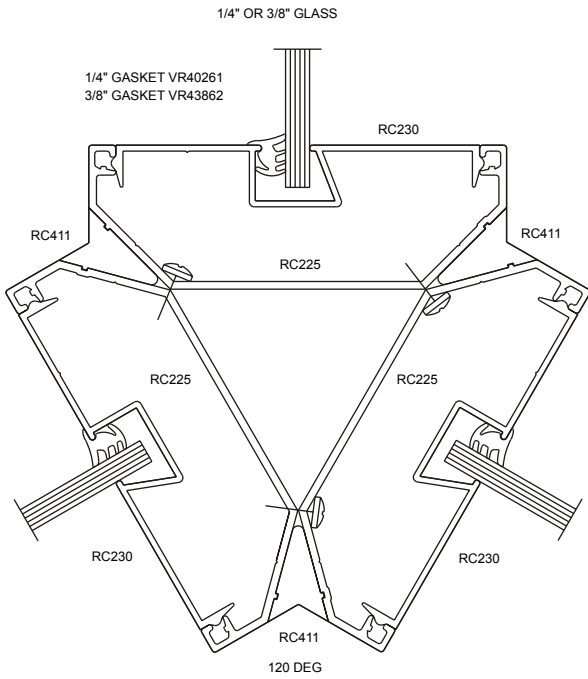

C2-007_375_3_way_corner_120_deg.dxf

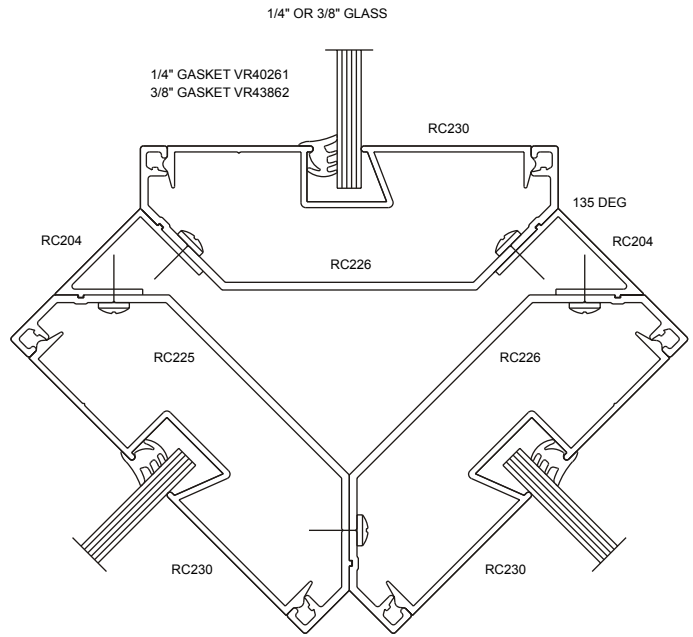

C2-008_375_3_way_corner_135_deg.dxf

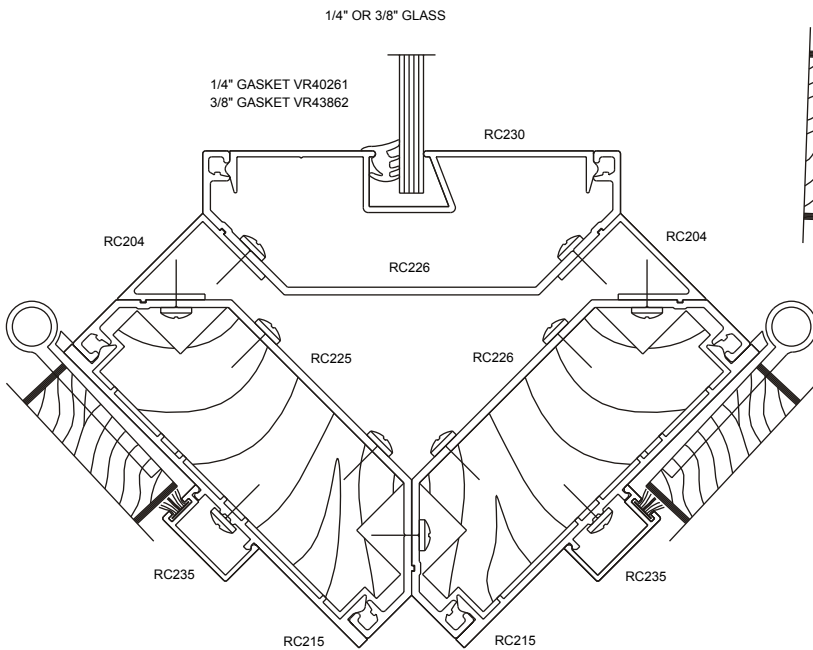

C2-009_375_3_way_corner_2_door_frames_and_glazing.dxf

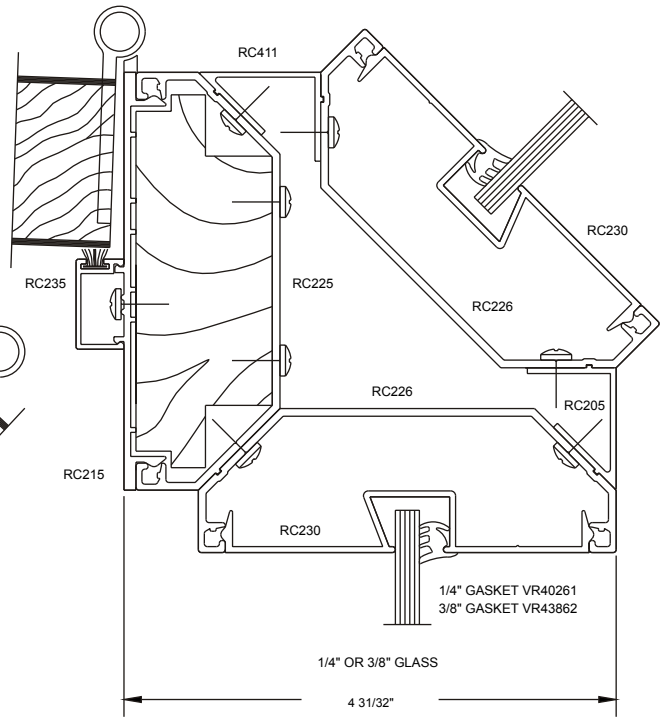

C2-010_375_3_way_corner_door_frame_and_2_glazing_2.dxf

CLASSIC Typical Details

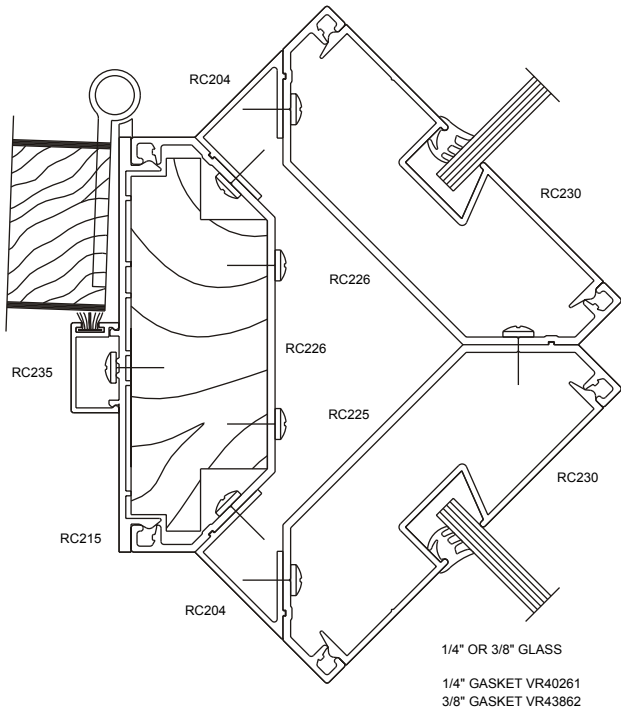

C2-011_375_3_way_corner_door_frame_and_2_glazing.dxf

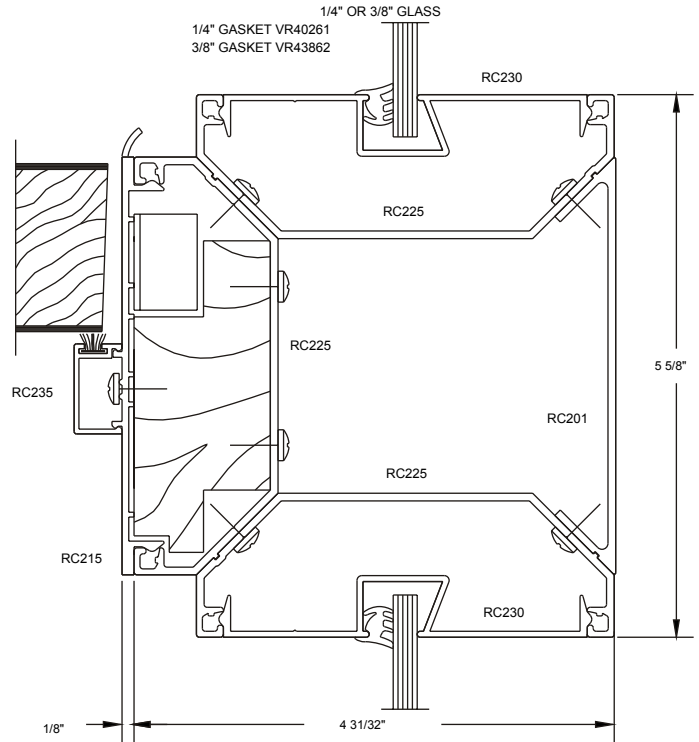

C2-012_375_3_way_corner_door_frame_and_2_glazing_90_deg.dxf

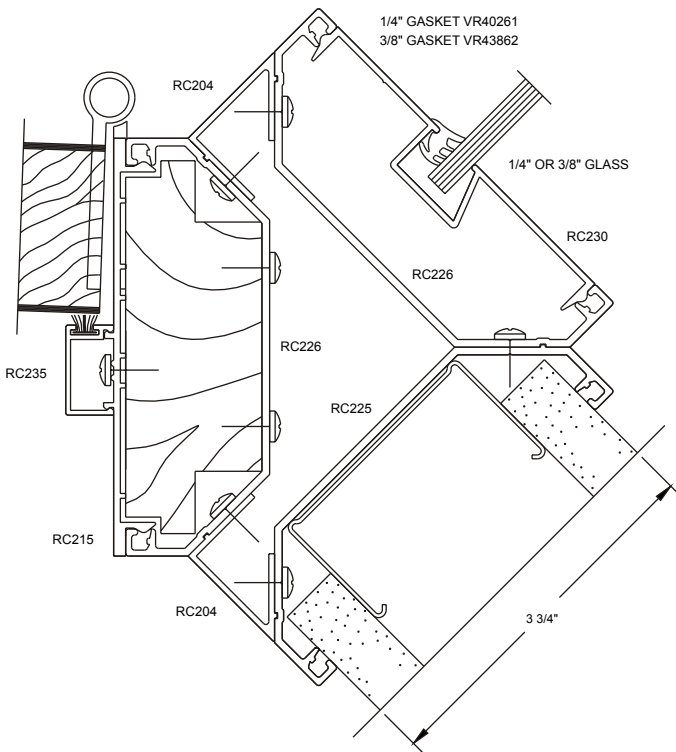

C2-013_375_3_way_corner_door_frame_glazing_and_drywall.dxf

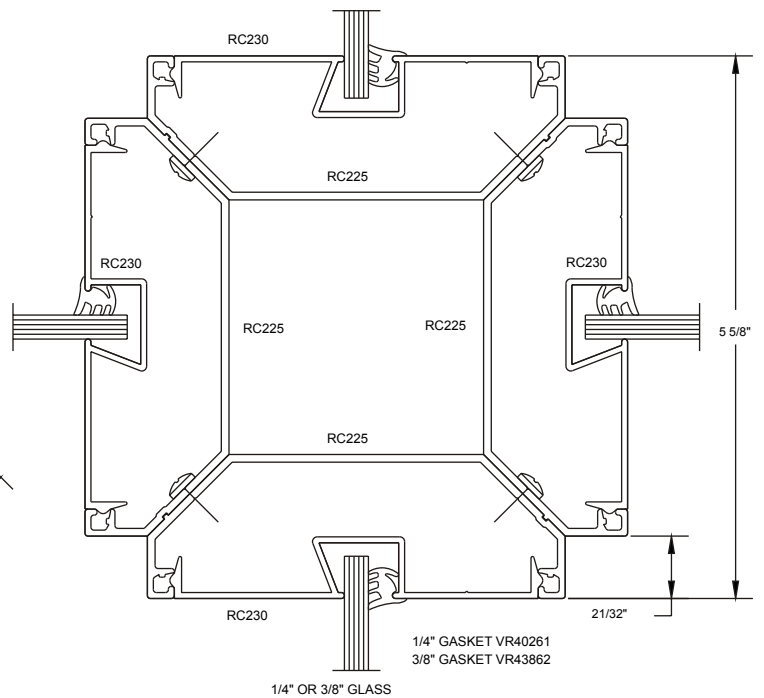

C2-014_375_4_way_corner.dxf

CLASSIC Typical Details

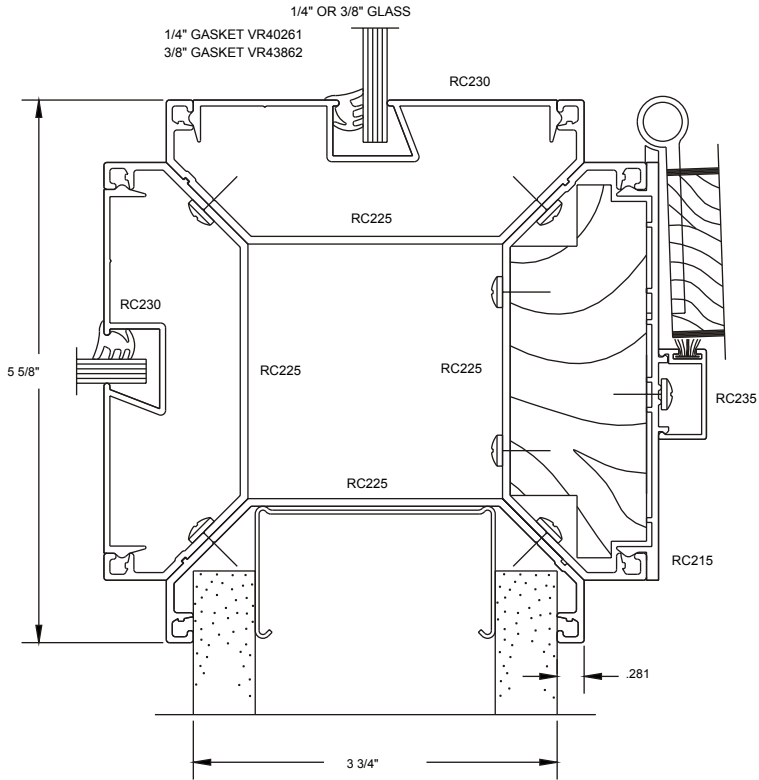

C2-015_375_4_way_corner_door_frame_2_glazing_and_drywall.dxf

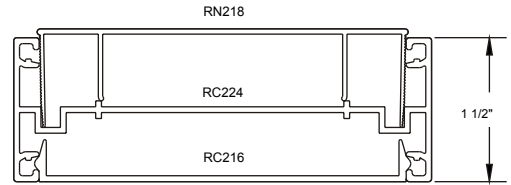

C2-016_375_cased_head_full_height.dxf
See also C2-018 SIM.

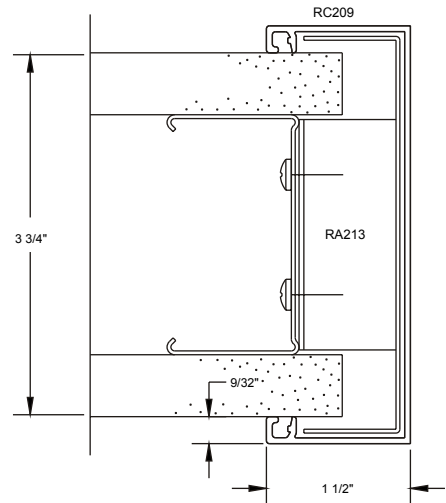

C2-018_375_cased_jamb_left_hand.dxf
See also C2-016

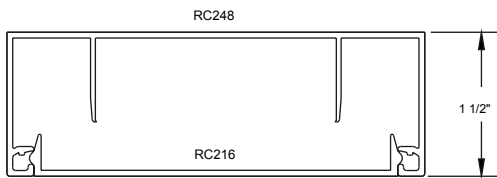

C2-017_375_cased_head_to_head_track.dxf

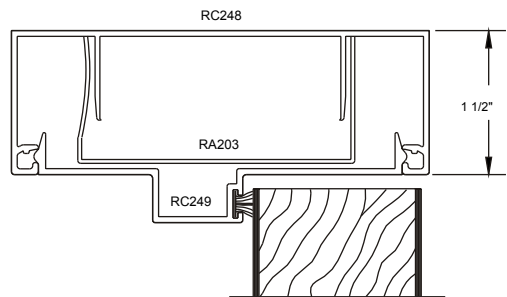

C2-021_375_door_frame_insert_to_head_track.dxf

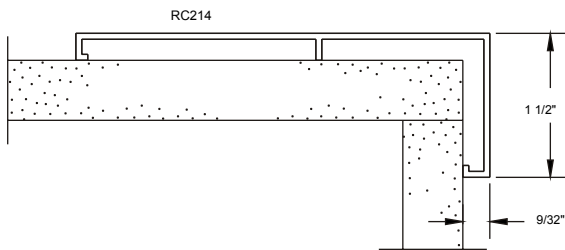

C2-019_375_closet_jamb.dxf

CLASSIC Typical Details

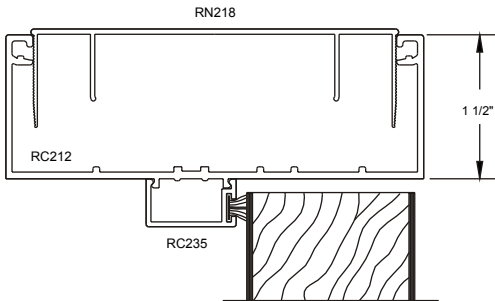

C2-022_375_door_head_full_height.dxf
See also C2-024, C2-025

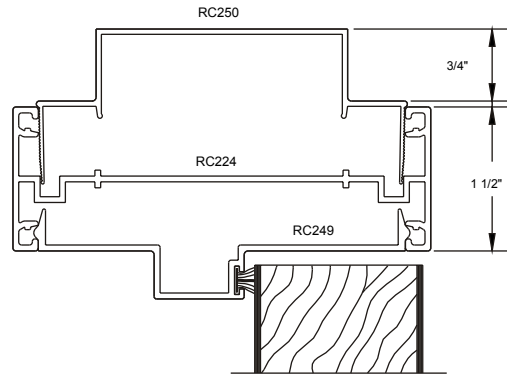

C2-023_375_door_head_full_height_at_sidelight_reveal_header.dxf
See also C2-026, C2-042

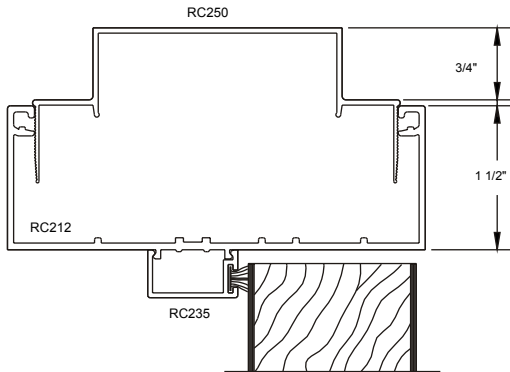

C2-024_375_door_head_full_height_with_reveal_header.dxf
See also C2-022, C2-025

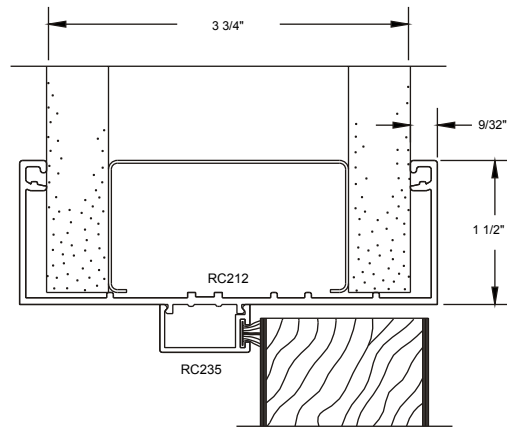

C2-025_375_door_head_partial_height.dxf
See also C2-022, C2-024

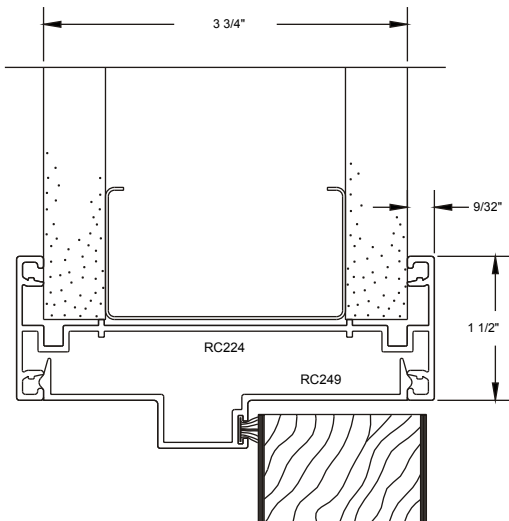

C2-026_375_door_head_partial_height_sidelite.dxf
See also C2-023, C2-042

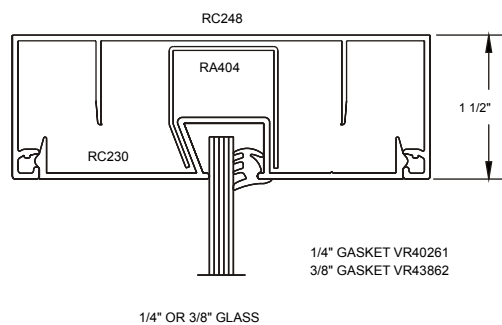

C2-027_375_glazing_insert_to_head_track.dxf
See also C2-032, C2-047

CLASSIC Typical Details

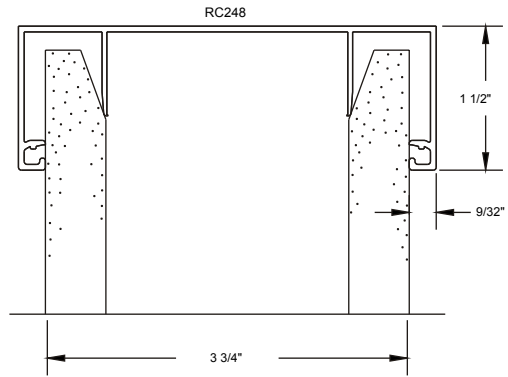
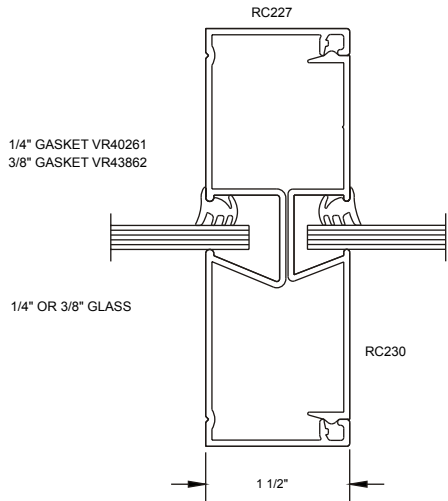

C2-029_375_header.dxf

C2-028_375_glazing_vertical_mullion.dxf
See also C2-049, C2-051

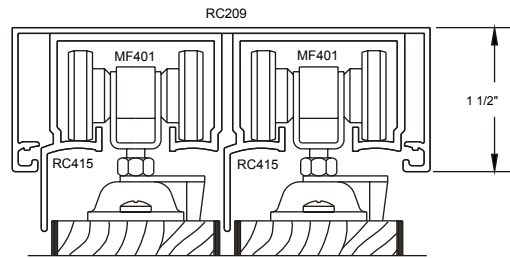
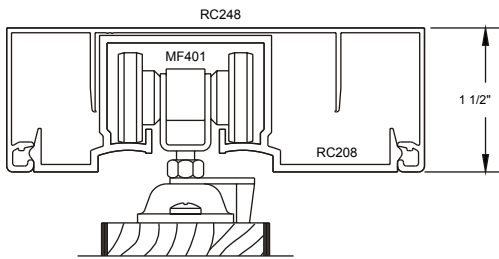

C2-031_375_head_at_bypassing_door.dxf

C2-030_375_head_at_bifold_door.dxf

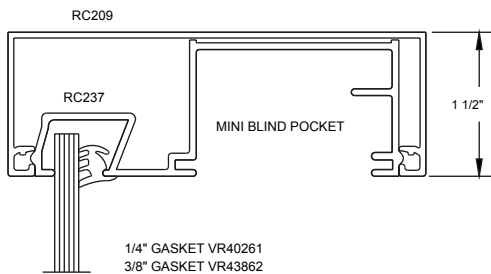

C2-032_375_head_with_blind_pocket.dxf
See also C2-027, C2-047

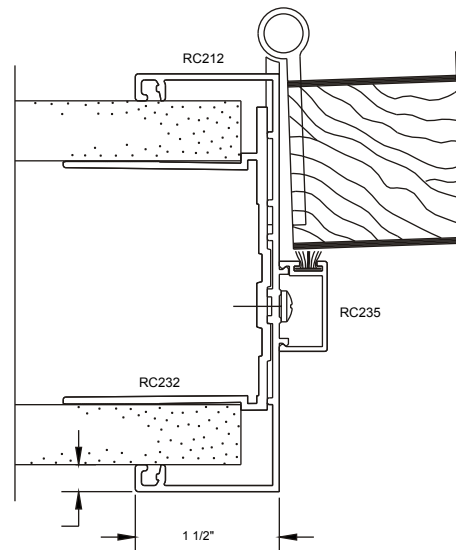

C2-033_375_hinge_jamb_left_hand.dxf
See also C2-034

CLASSIC Typical Details

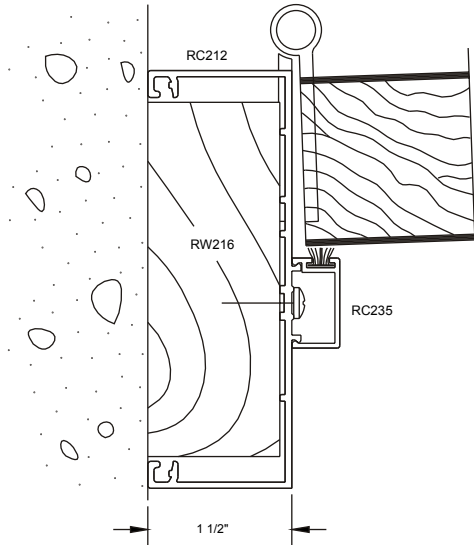

C2-034_375_hinge_jamb_left_hand_at_masonry.dxf
See also C2-033

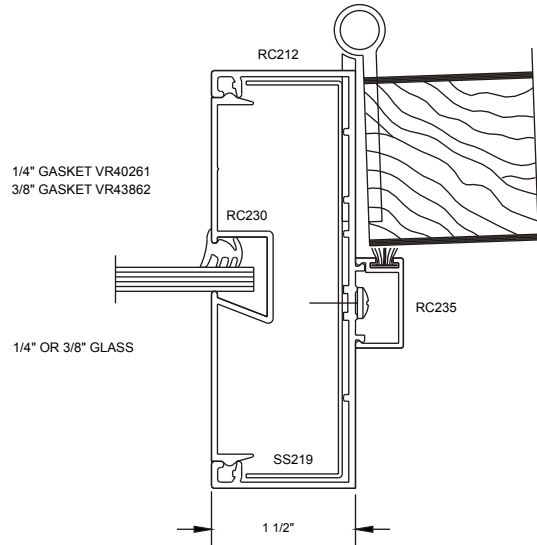

C2-035_375_hinge_jamb_left_hand_with_sidelight.dxf
See also C2-057, C2-058

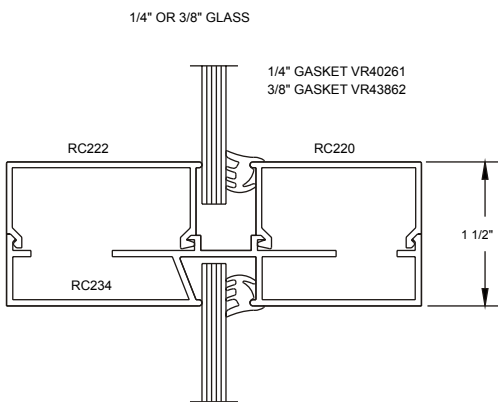

C2-036_375_horizontal_mullion.dxf
See also C2-046

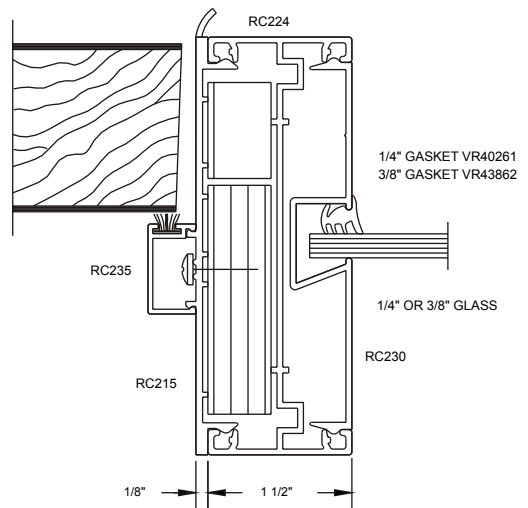

C2-037_375_vertical_mullion_strike_jamb_at_glass.dxf

CLASSIC Typical Details

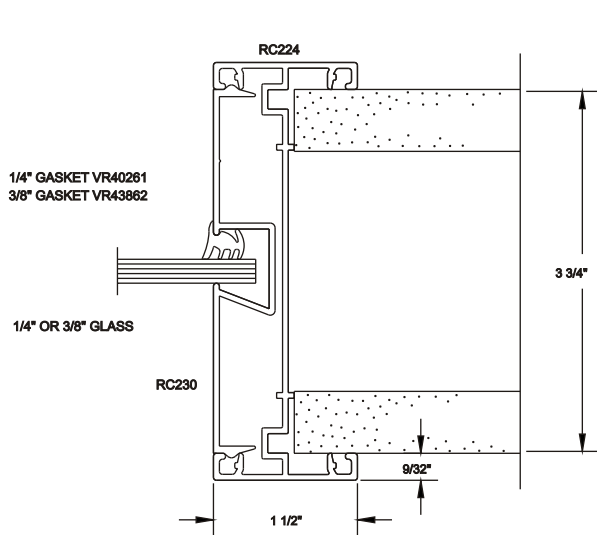

C2-038_375_vertical_mullion_with_glazing_insert.dxf
See also C2-044, C2-045, C2-052, C2-055, C2-061

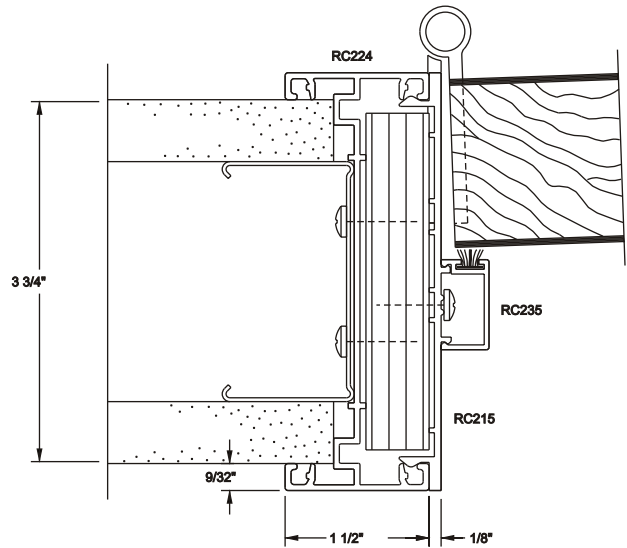

C2-039_375_vertical_mullion_with_hinge_jamb.dxf

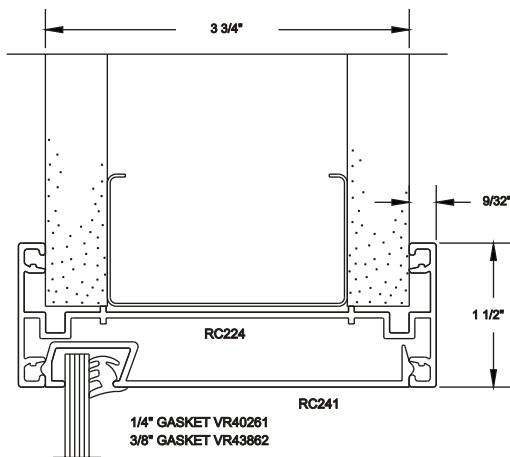

C2-040_375_horizontal_mullion_with_offset_glazing.dxf
See also C2-041, C2-043

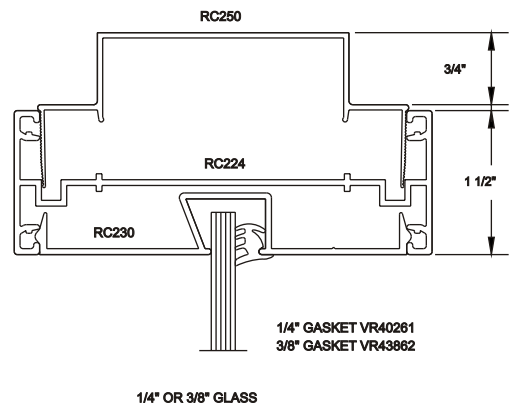

C2-041_375_horiz_mullion_glass_insert_and_reveal_head_track.dxf
See also C2-040, C2-043

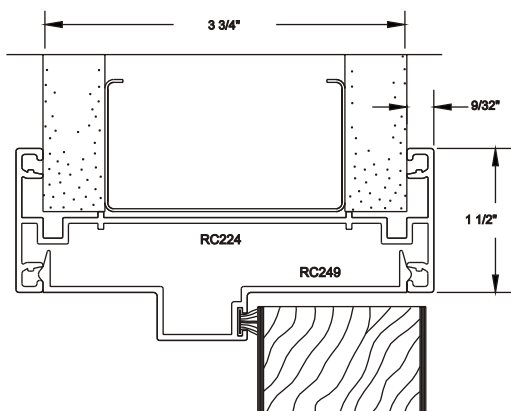

C2-042_375_horiz_mullion_with_door_frame_insert.dxf
See also C2-023, C2-026

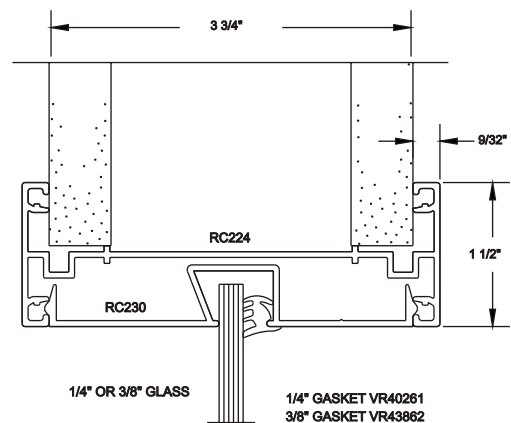

C2-043_375_horiz_mullion_with_glazing_insert.dxf
See also C2-040, C2-041

CLASSIC Typical Details

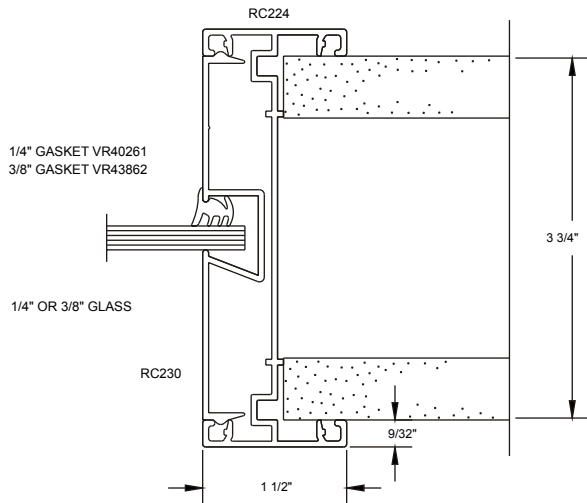

C2-044_375_jamb_right_hand.dxf
See also C2-038, C2-045, C2-052, C2-055, C2-061

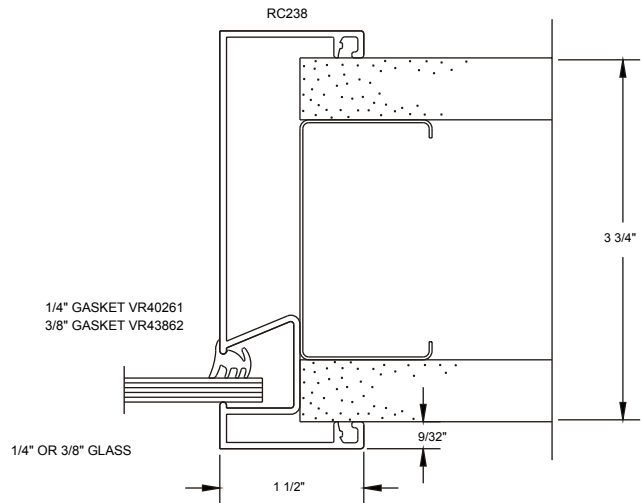

C2-045_375_offset_glazing_jamb.dxf
See also C2-038, C2-044, C2-052, C2-055, C2-061

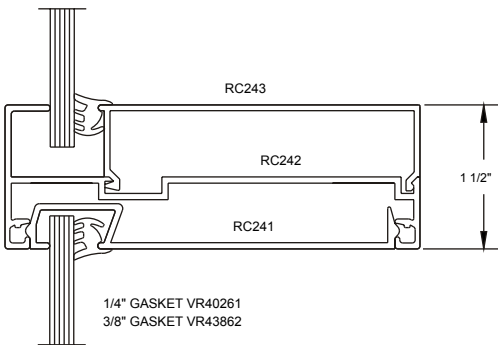

C2-046_375_offset_horizontal_mullion.dxf
See also C2-036

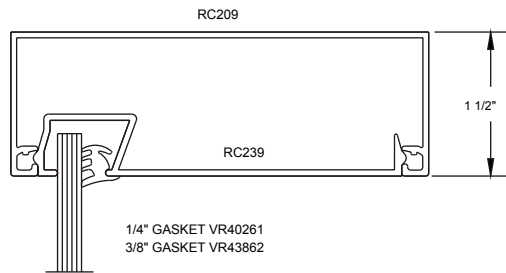

C2-047_375_offset_insert_to_head_track.dxf
See also C2-027, C2-032

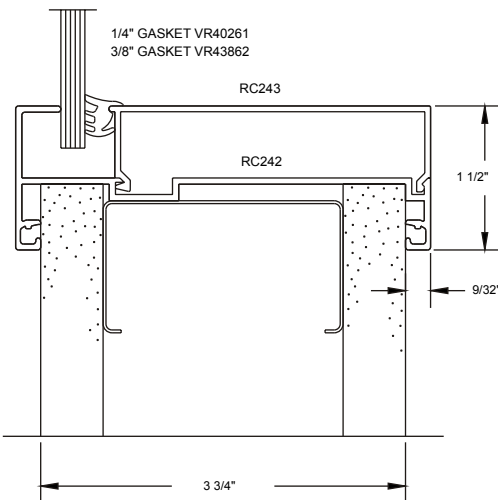

C2-048_375_offset_sill_partial_height.dxf
See also C2-053, C2-054

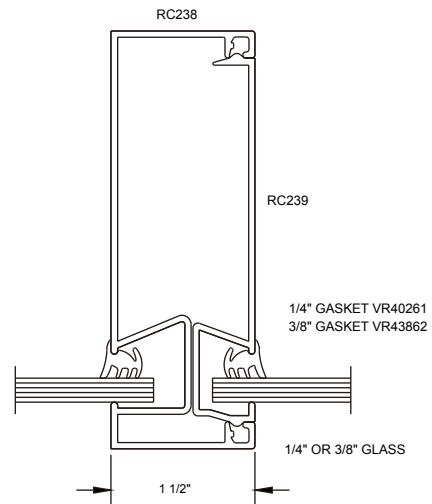

C2-049_375_offset_vertical_mullion.dxf
See also C2-028, C2-051

CLASSIC Typical Details

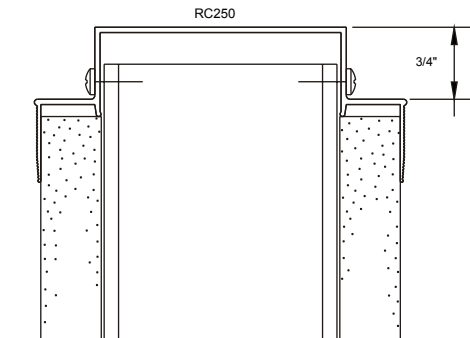

C2-050_375_recessed_reveal_header.dxf

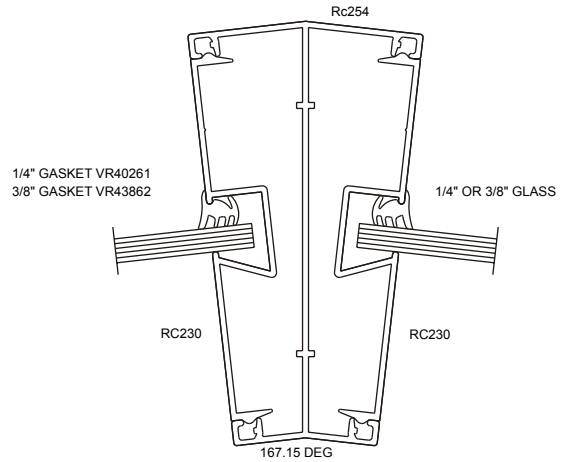

C2-051_375_segmented_vert_mull_with_2_glazing_inserts.dxf
See also C2-028, C2-049

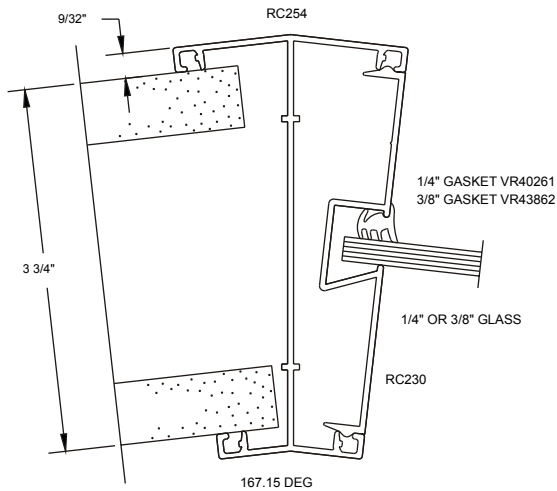

C2-052_375_segmented_vert_mull_with_glazing_and_drywall.dxf
See also C2-038, C2-044, C2-045, C2-055, C2-061

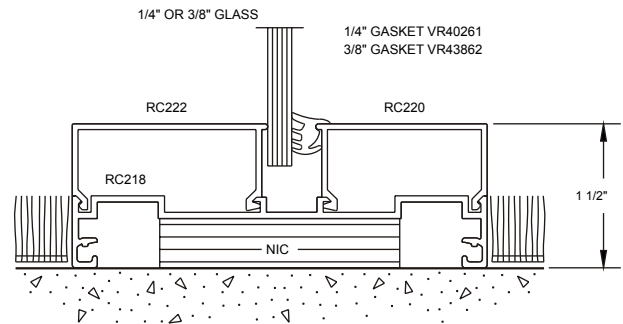

C2-053_375_sill_full_height.dxf
See also C2-048, C2-054

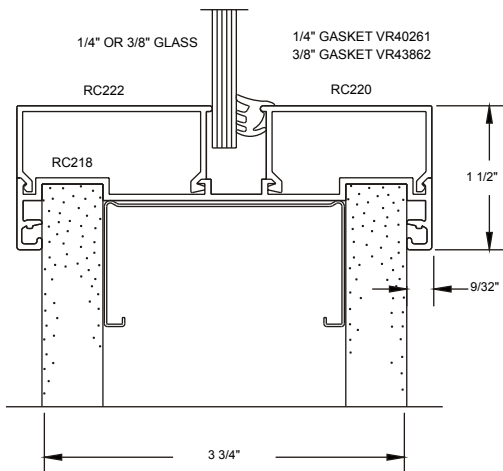

C2-054_375_sill_partial_height.dxf
See also C2-048, C2-053

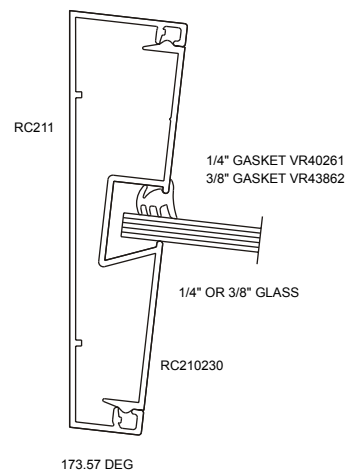

C2-055_375_starter_segmented_mullion.dxf
See also C2-038, C2-044, C2-045, C2-052, C2-061

CLASSIC Typical Details

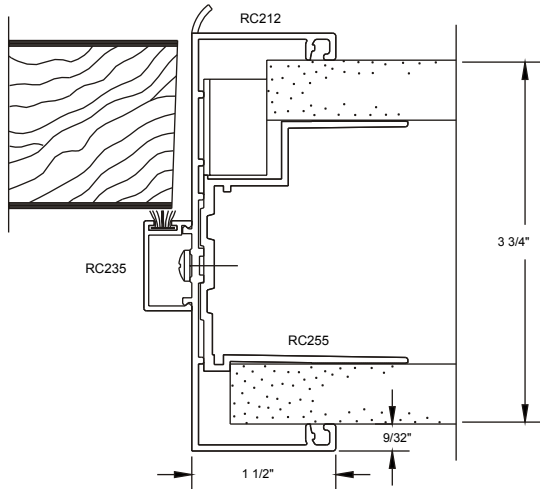

C2-056_375_strike_jamb_left_hand.dxf

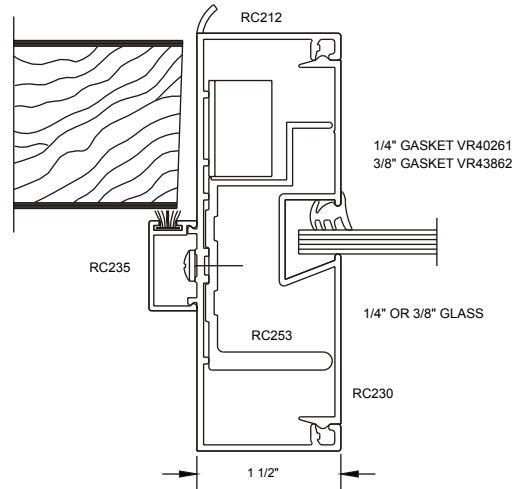

C2-057_375_strike_jamb_right_hand_with_sidelight.dxf
See also C2-035, C2-058

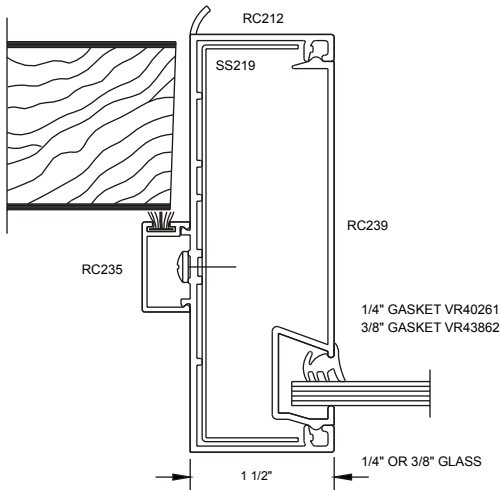

C2-058_375_strike_jamb_with_offset_glazing.dxf
See also C2-035, C2-057

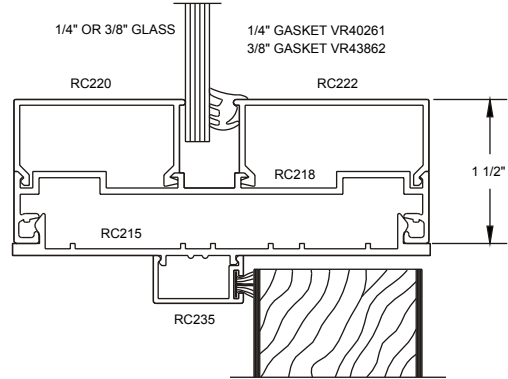

C2-059_375_transom_bar.dxf

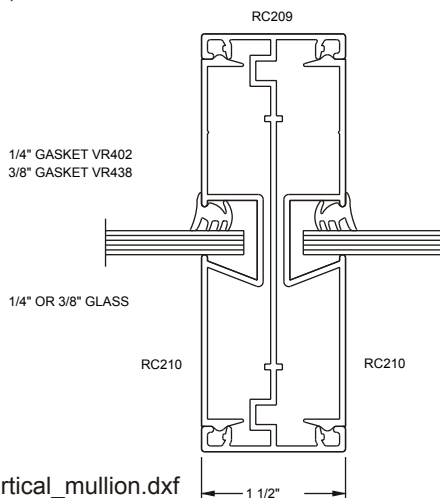

C2-060_375_vertical_mullion.dxf

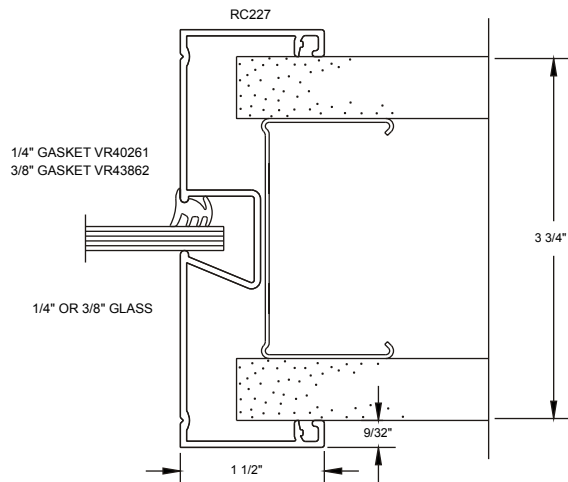

C2-061_375_wall_glazing_jamb.dxf
See also C2-038, C2-044, C2-045, C2-052, C2-055

CLASSIC Typical Details

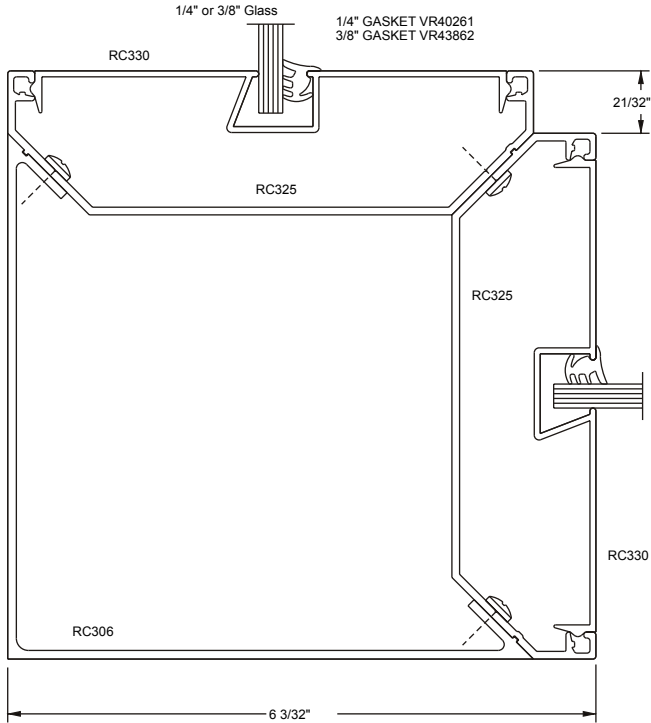

C3-001_487_2_way_corner.dxf

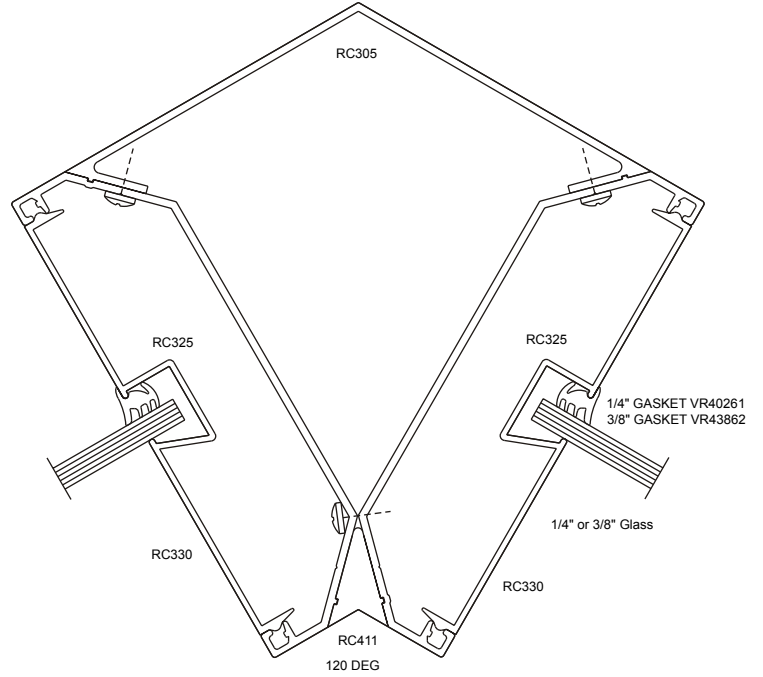

C3-002_487_2_way_corner_120_deg.dxf

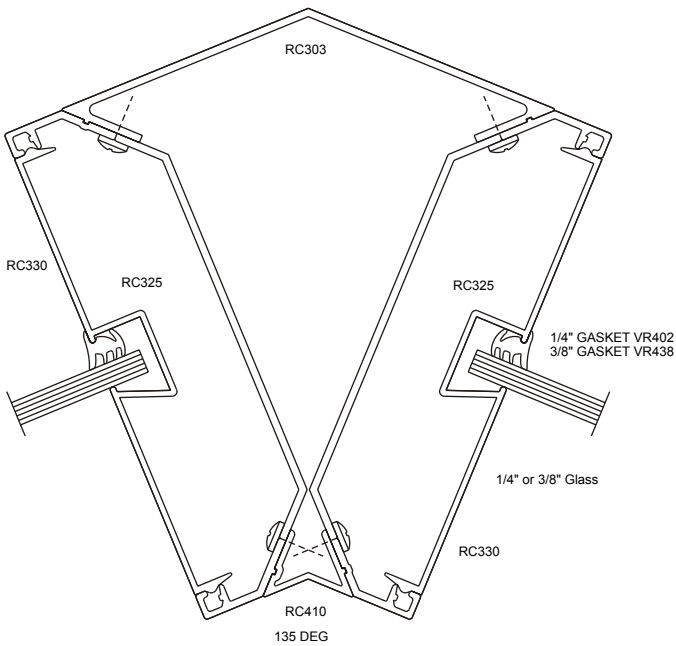

C3-003_487_2_way_corner_135_deg.dxf

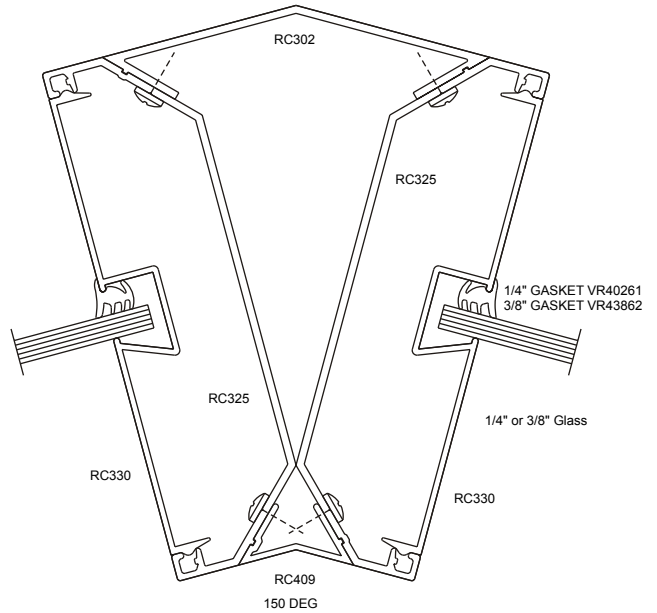

C3-004_487_2_way_corner_150_deg.dxf

CLASSIC Typical Details

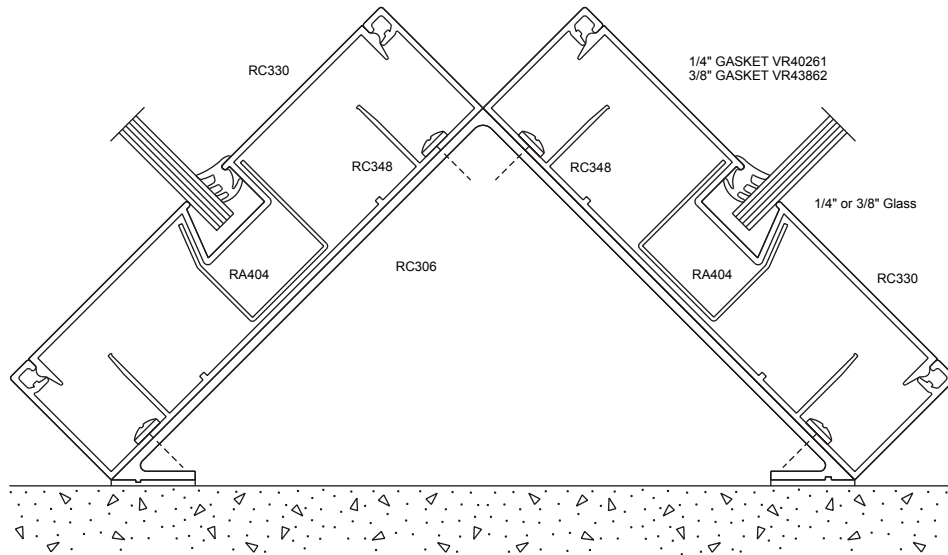

C3-005_487_2_way_corner_to_masonry.dxf

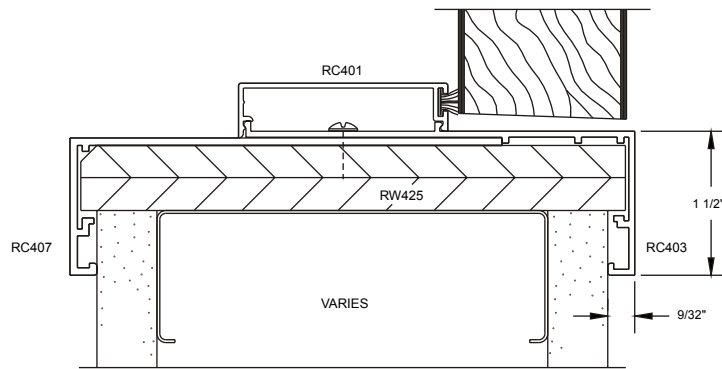

C3-006_487_20_min_adjustable_door_frame_lar_with_lar_stop.dxf
See also C3-007, C3-008, C3-009, C3-018

CLASSIC Typical Details

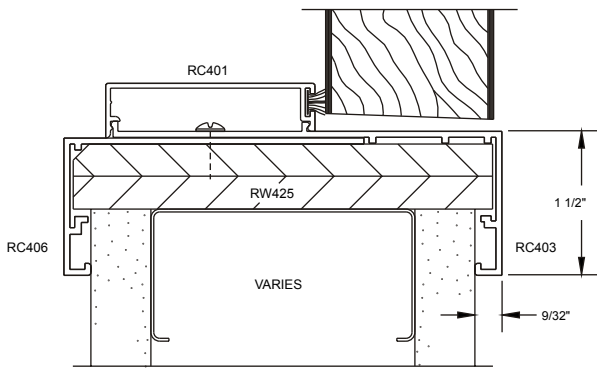

C3-007_487_20_min_adjustable_door_frame_med_with_lar_stop.dxf
See also C3-006, C3-008, C3-009, C3-018

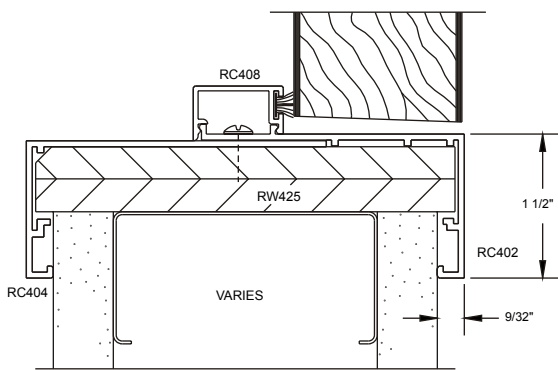

C3-009_487_20_min_adjustable_door_frame_with_sml_stop.dxf
See also C3-006, C3-007, C3-008, C3-018

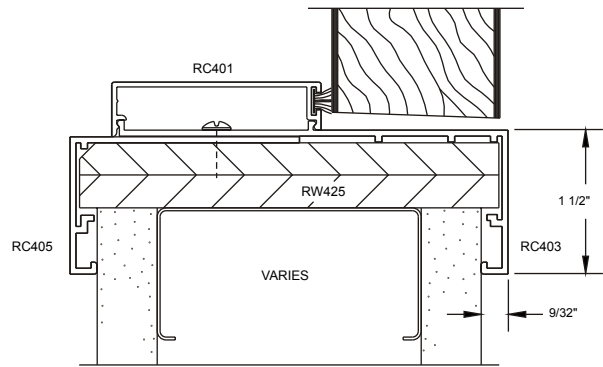

C3-008_487_20_min_adjustable_door_frame_sml_with_lar_stop.dxf
See also C3-006, C3-007, C3-009, C3-018

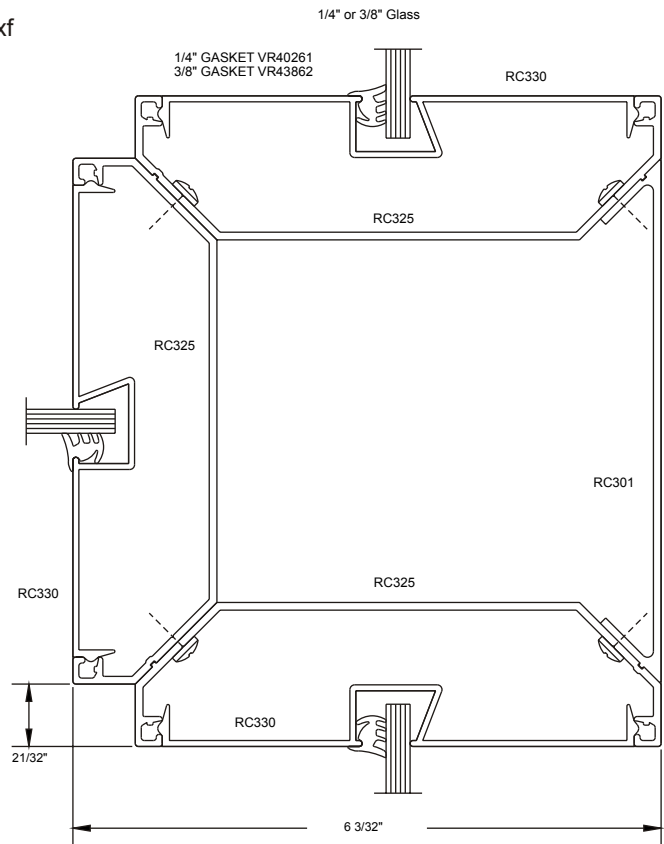

C3-010_487_3_way_corner.dxf

CLASSIC Typical Details

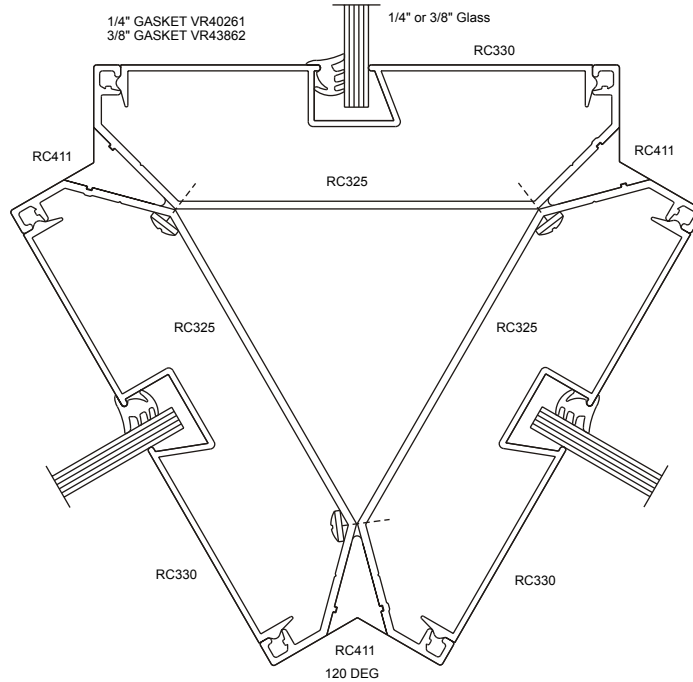

C3-011_487_3_way_corner_120_deg.dxf

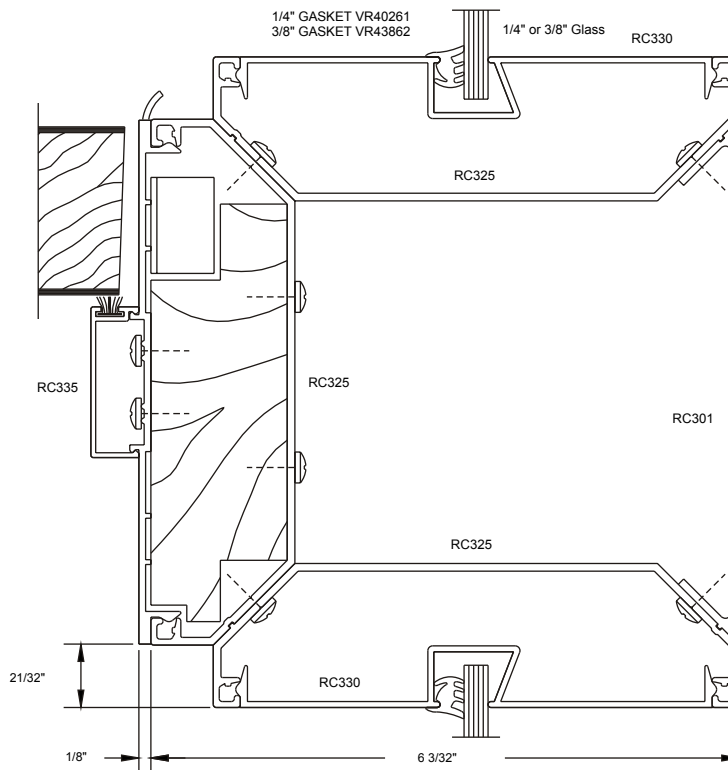

C3-012_487_3_way_corner_door_frame_and_2_glazing.dxf

CLASSIC Typical Details

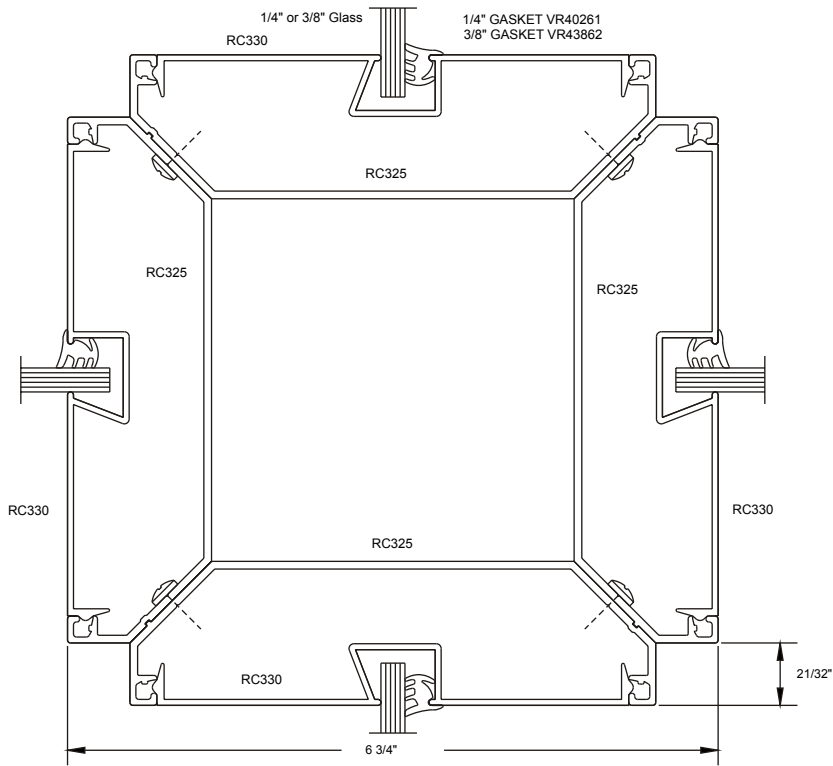

C3-013_487_4_way_corner.dxf

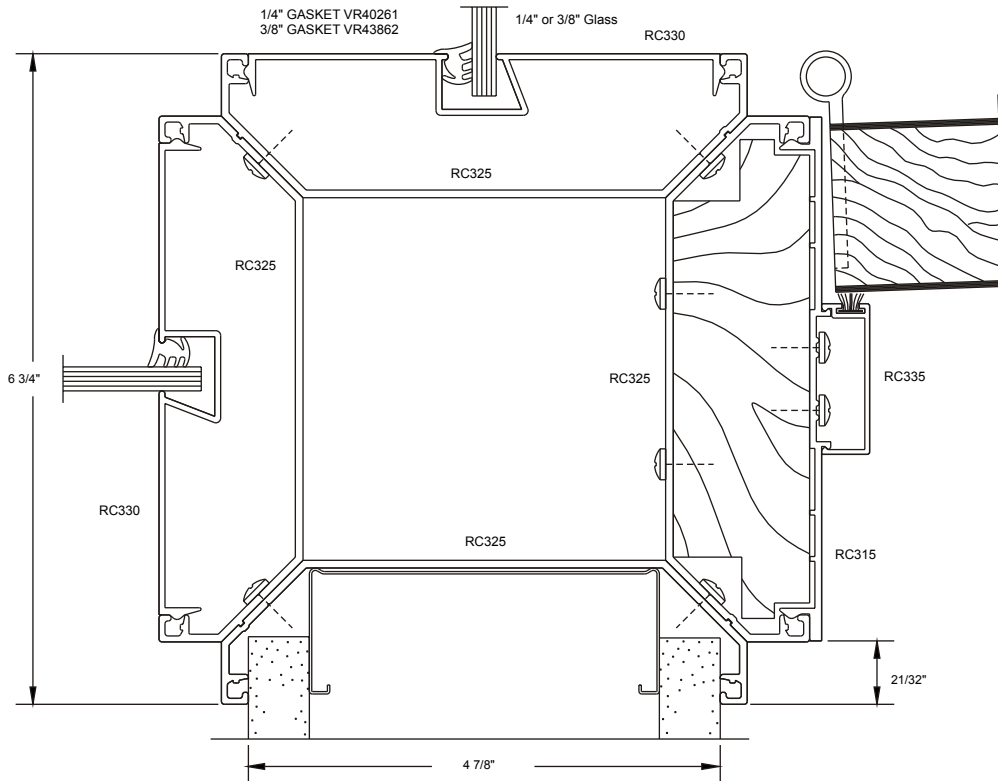

C3-014_487_4_way_corner_door_frame_2_glazing_and_drywall.dxf

CLASSIC Typical Details

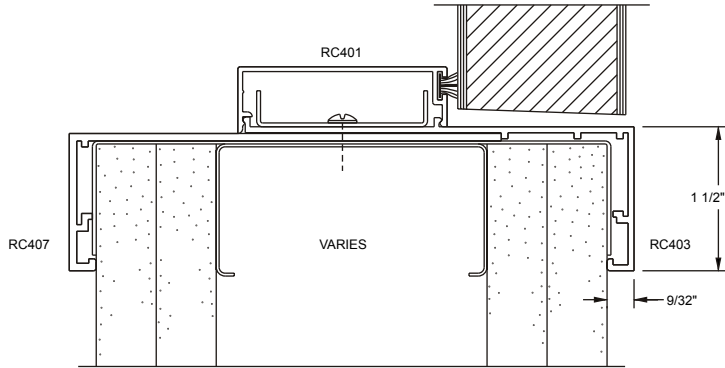

C3-015_487_90_min_adjustable_door_frame_lar_with_lar_stop.dxf
See also C3-016, C3-017

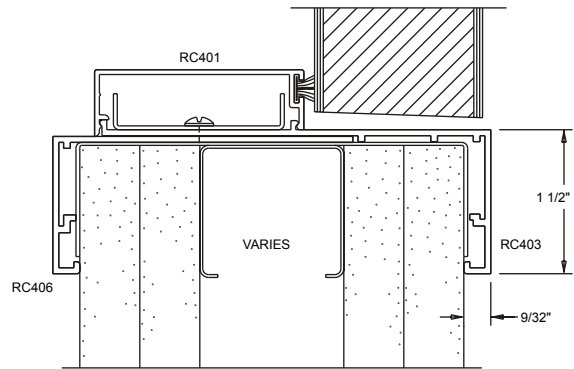

C3-016_487_90_min_adjustable_door_frame_med_with_lar_stop.dxf
See also C3-015, C3-017

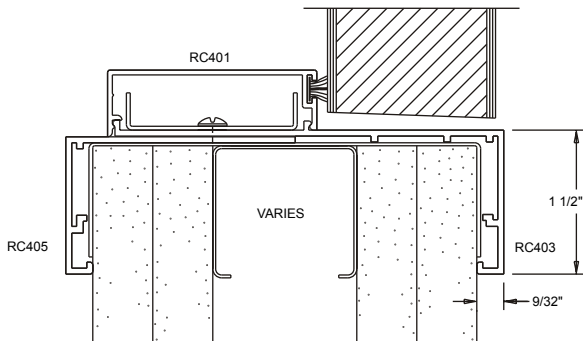

C3-017_487_90_min_adjustable_door_frame_sml_with_lar_stop.dxf
See also C3-015, C3-016

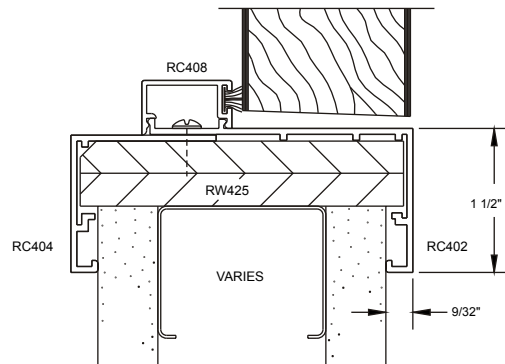

C3-018_487_adjustable_door_frame.dxf
See also C3-006, C3-007, C3-008, C3-009

CLASSIC Typical Details

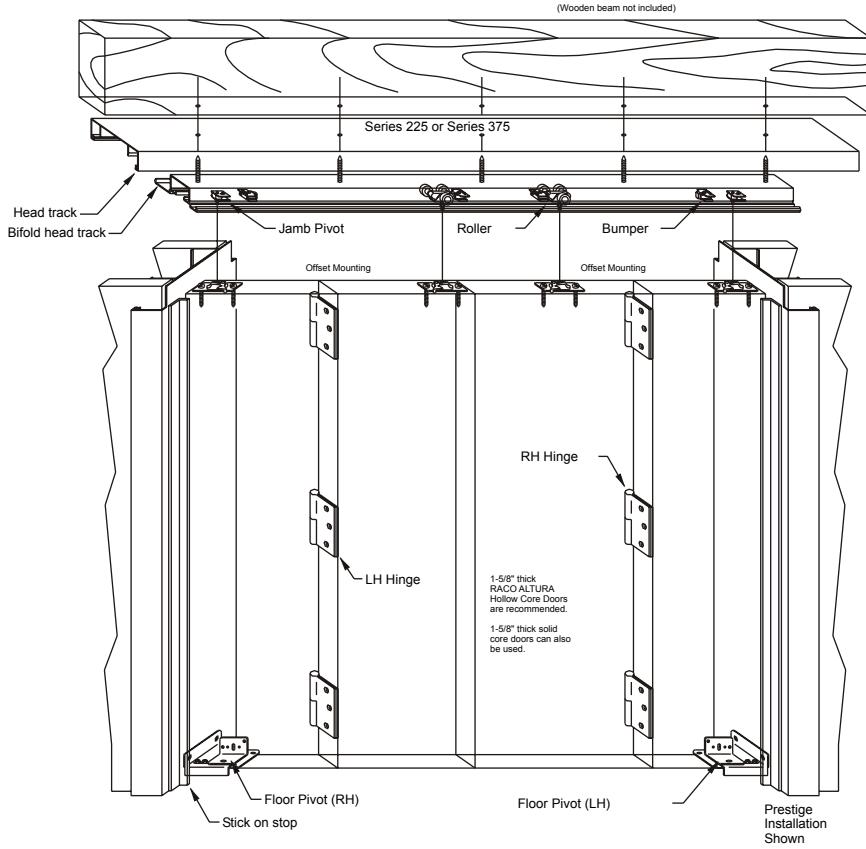

C3-019_487_bifold_frame_elevation_view.dxf
See also C3-020, C3-022, C3-039

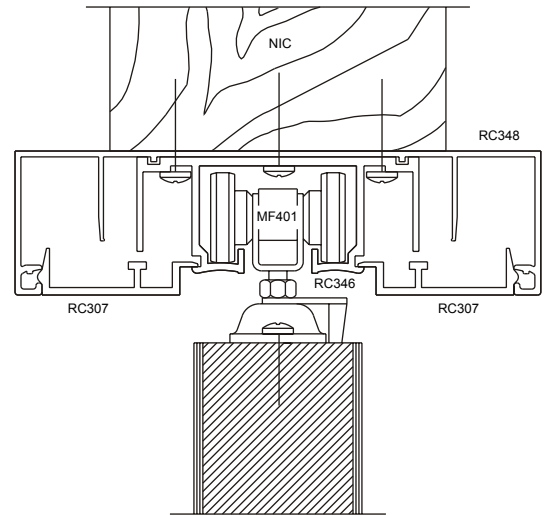

C3-020_487_bifold_frame_head_2.dxf
See also C3-019, C3-022, C3-039

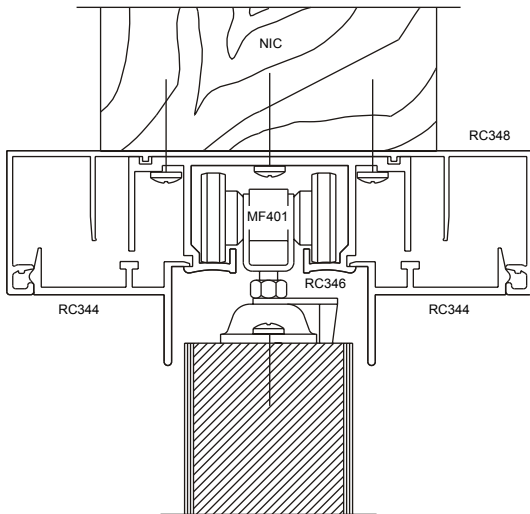

C3-021_487_pocket_frame_head.dxf
See also C3-051, C3-052

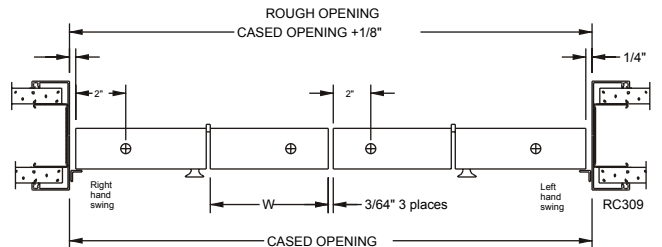

C3-022_487_bifold_frame_top_view.dxf
See also C3-019, C3-020, C3-039

RACO Interior OfficeFronts™

CLASSIC Typical Details

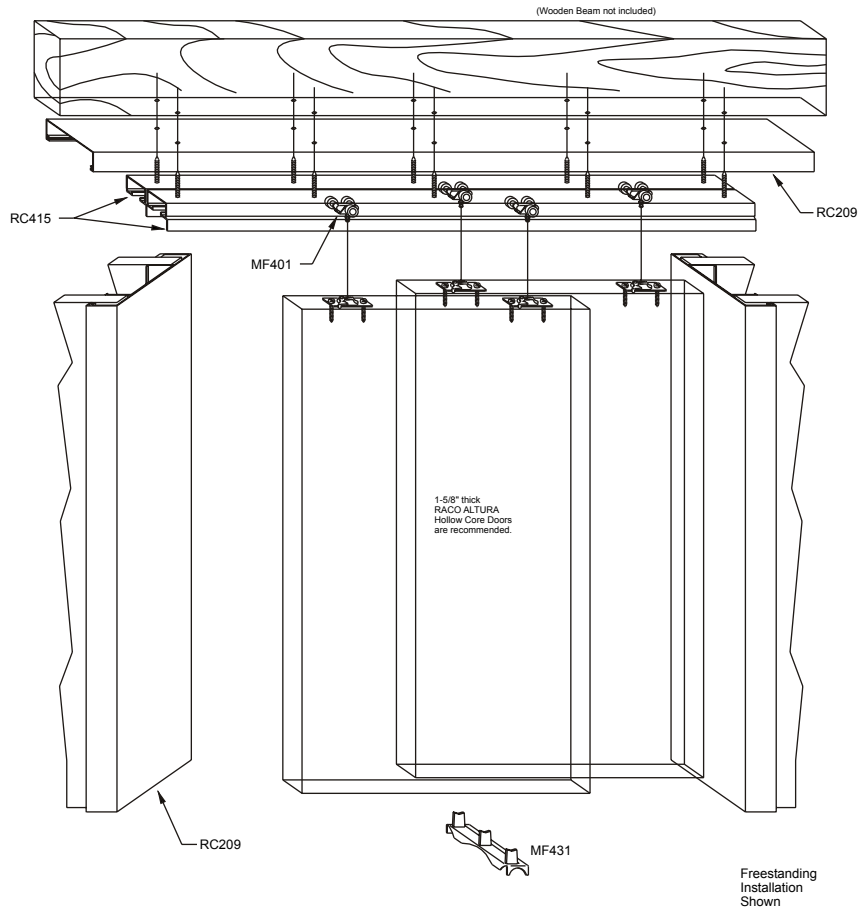

C3-023_487_bypassing_frame_elevation_view.dxf
See also C3-024, C3-038

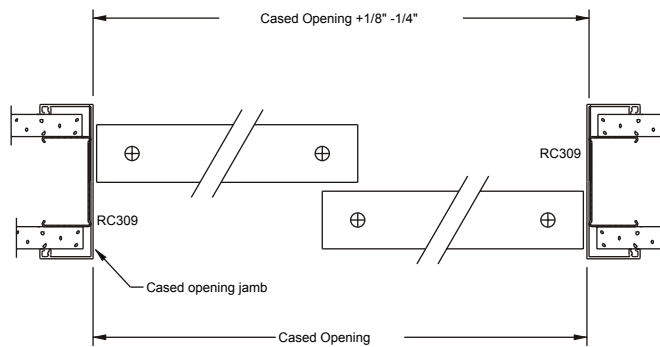

C3-024_487_bypassing_frame_top_view.dxf
See also C3-023, C3-038

CLASSIC Typical Details

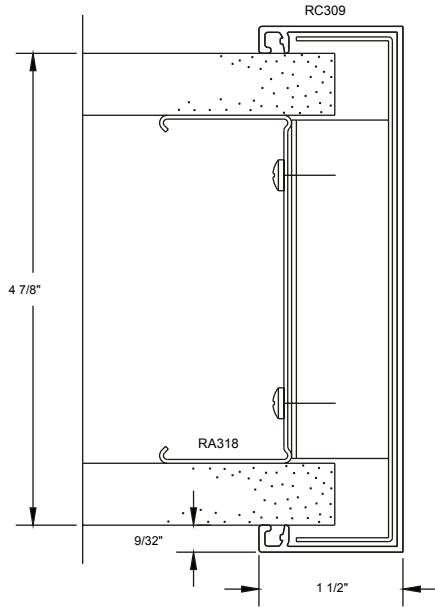

C3-025_487_cased_jamb_left_hand.dxf

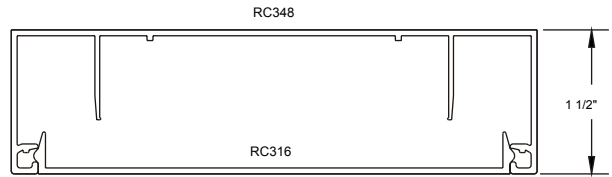

C3-026_487_cased_opening_to_head_track.dxf

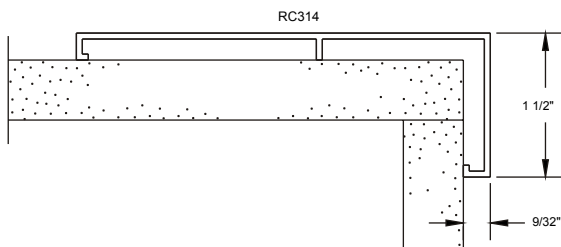

C3-027_487_closet_jamb.dxf

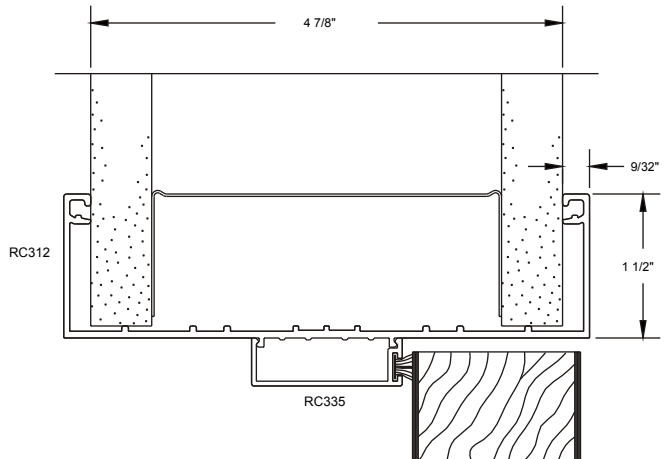

C3-028_487_door_frame_head_to_drywall.dxf
See also C3-029, C3-032

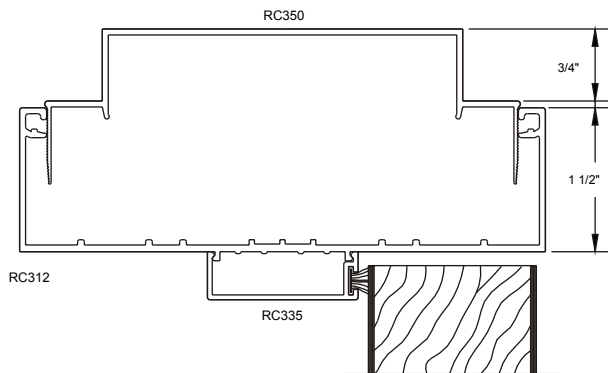

C3-029_487_door_frame_head_to_reveal_track.dxf
See also C3-028, C3-032

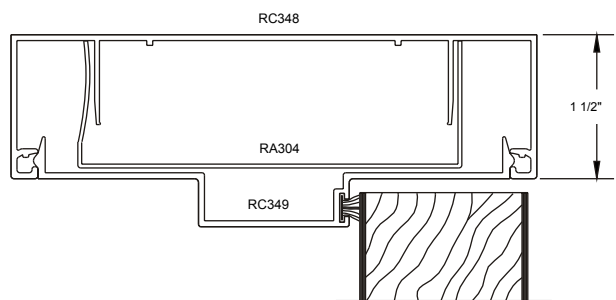

C3-030_487_door_frame_insert_to_head_track.dxf

CLASSIC Typical Details

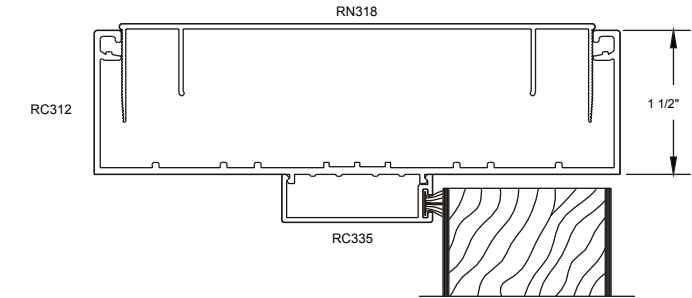
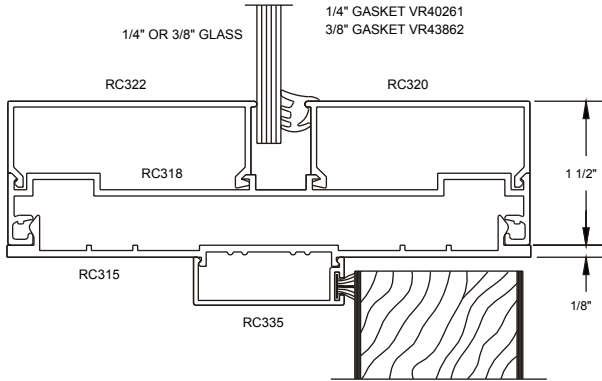

C3-032_487_door_head_full_height.dxf
See also C3-028, C3-029

C3-031_487_door_head_at_transom.dxf

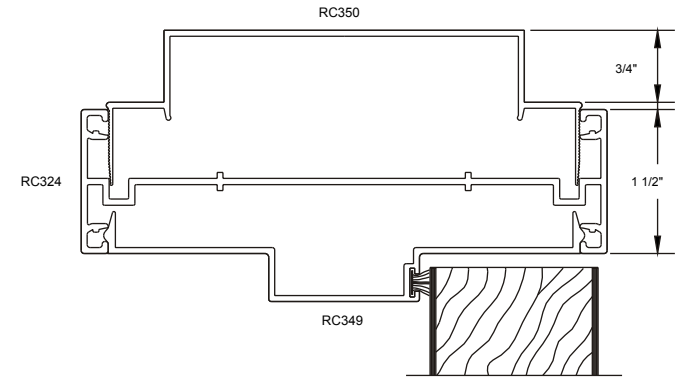
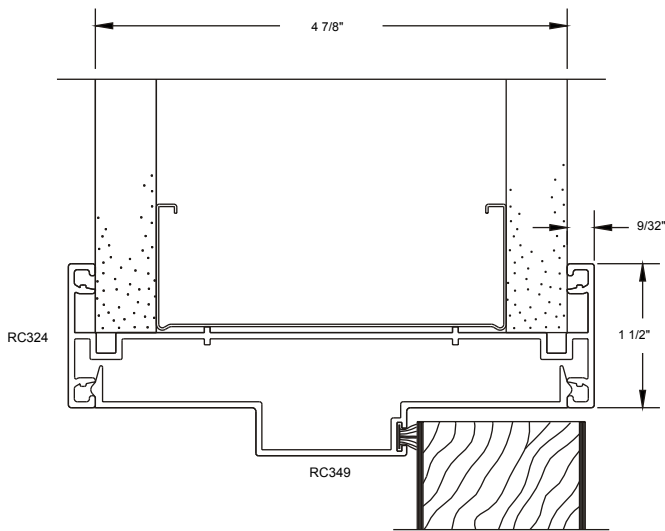

C3-034_487_door_head_hz_mull_full_height_with_reveal_header.dxf
See also C3-033

C3-033_487_door_head_horiz_mullion_partial_height.dxf
See also C3-034

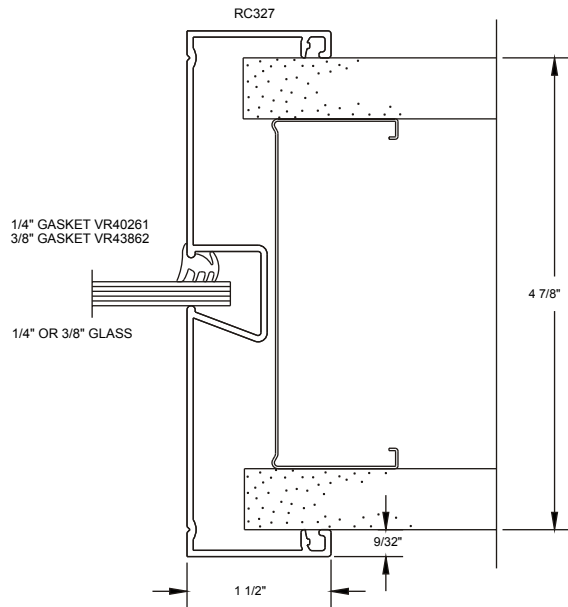
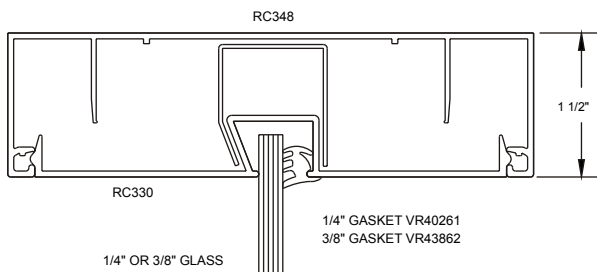

C3-035_487_glazing_insert_to_head_track.dxf

C3-036_487_glazing_wall_jamb.dxf
See also C3-049

CLASSIC Typical Details

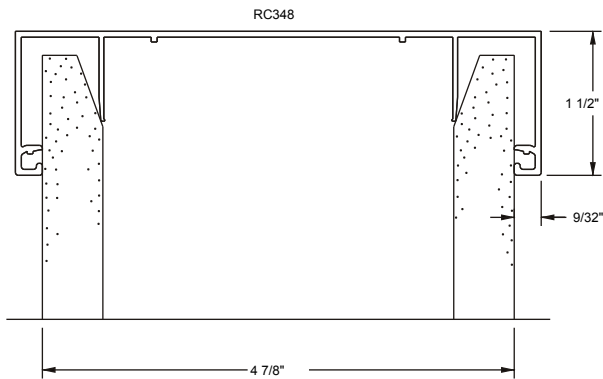

C3-037_487_header.dxf

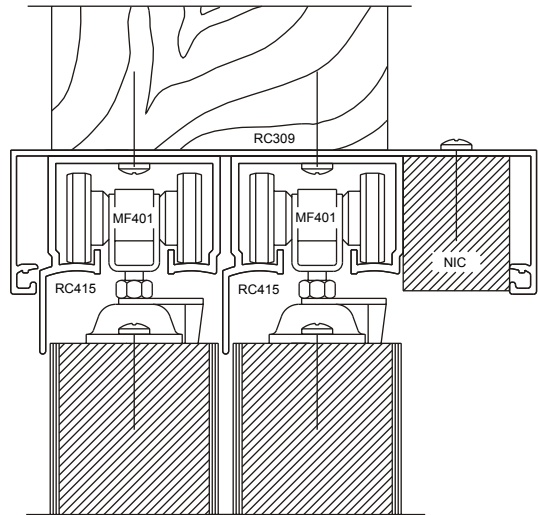

C3-038_487_head_at_double_bypassing_door.dxf
See also C3-023, C3-024

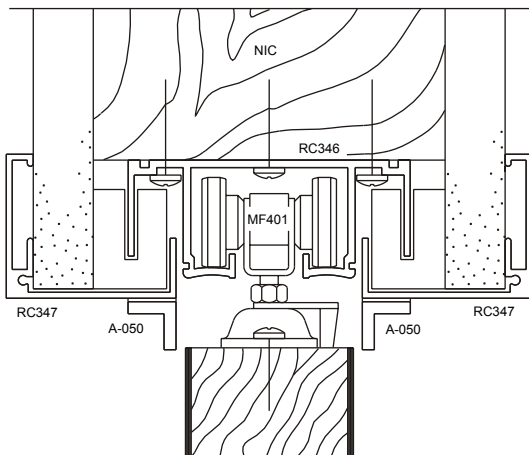

C3-039_487_head_at_single_bifold_door.dxf
See also C3-019, C3-020, C3-022

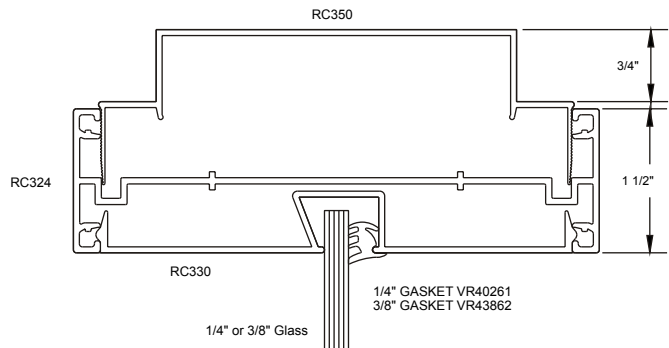

C3-040_487_head_full_height_horiz_mull_with_reveal_header.dxf
See also C3-041

CLASSIC Typical Details

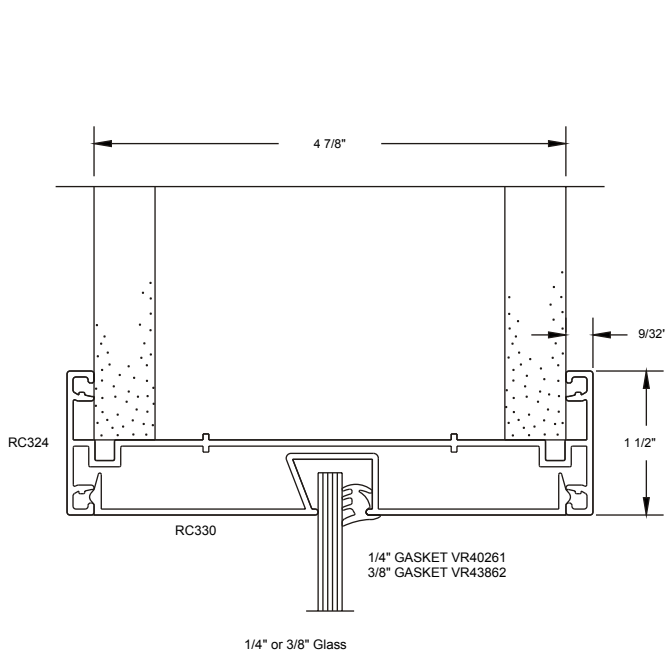

C3-041_487_head_horizontal_mullion_partial_height.dxf
See also C3-040

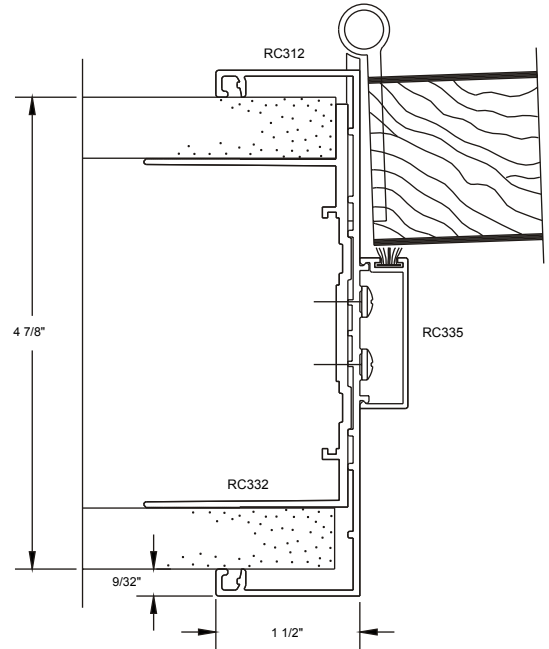

C3-042_487_hinge_door_frame.dxf
See also C3-043

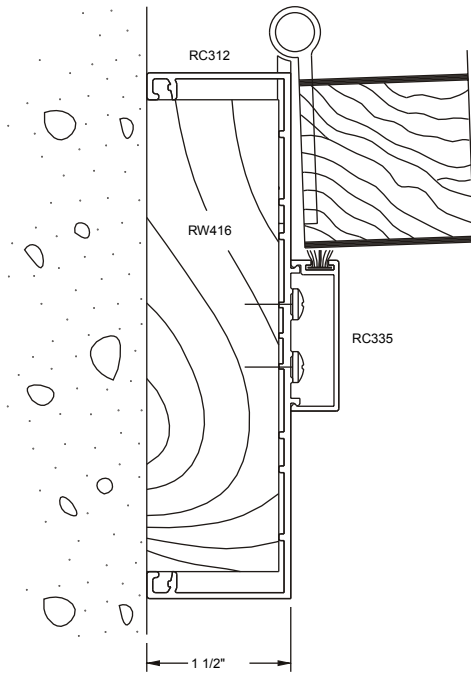

C3-043_487_hinge_door_frame_to_masonry.dxf
See also C3-042

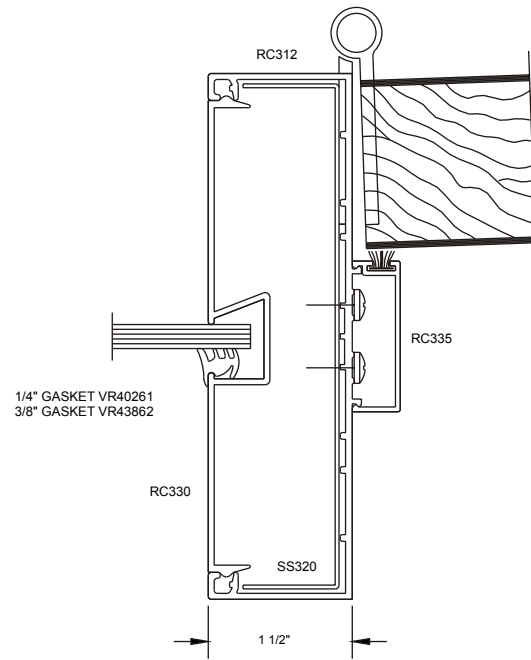

C3-044_487_hinge_door_frame_with_glazing.dxf
See also C3-058

CLASSIC Typical Details

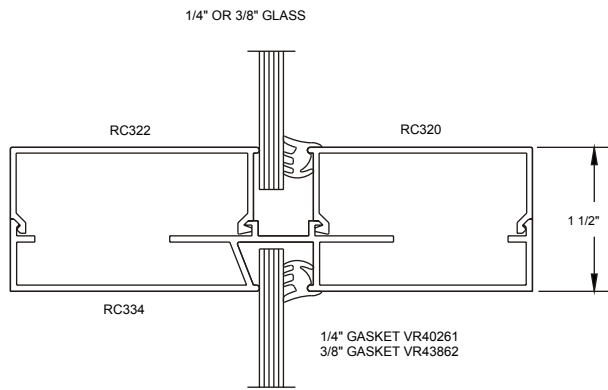

C3-045_487_horizontal_mullion.dxf

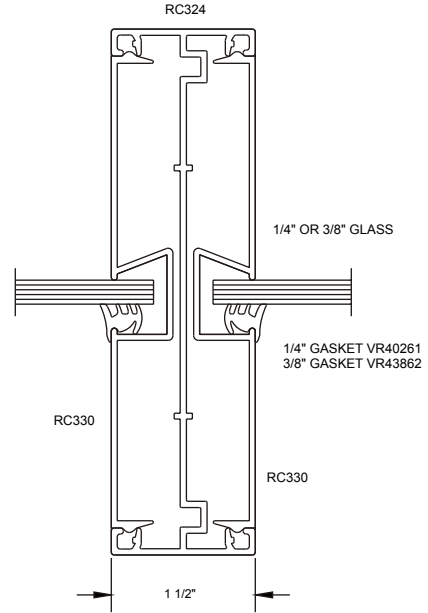

C3-046_487_vertical_mullion_with_2_glazing.dxf
See also C3-059

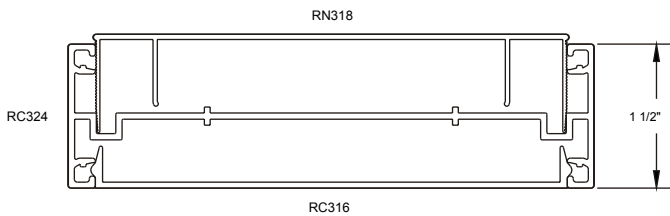

C3-047_487_horiz_mullion_cased_opening_head.dxf

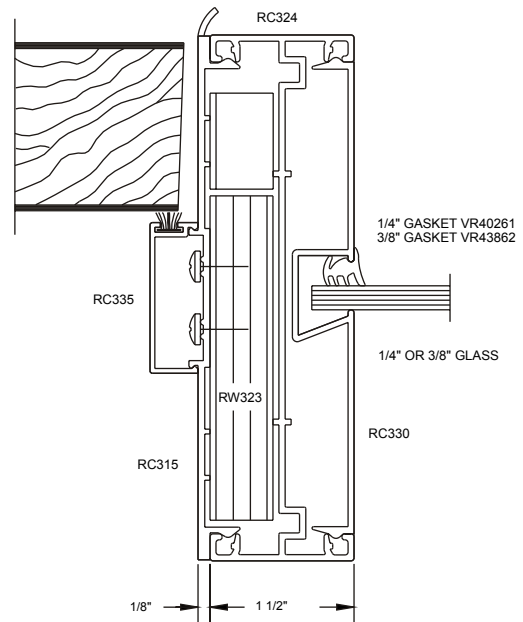

C3-048_487_vert_mullion_strike_door_frame_at_glass.dxf

CLASSIC Typical Details

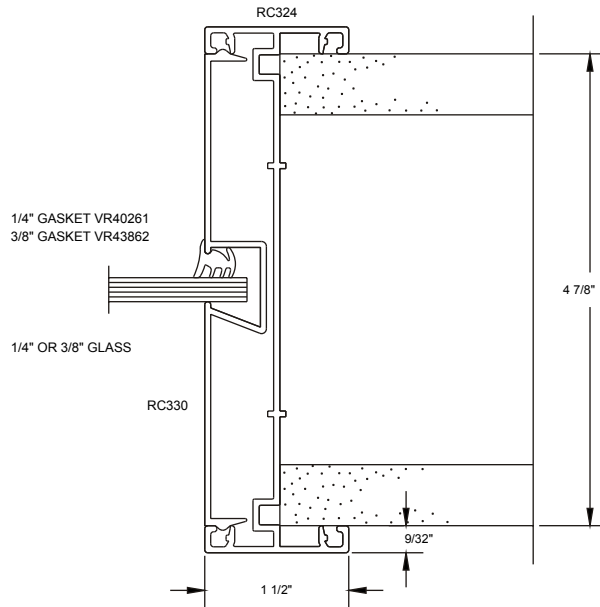

C3-049_487_vert_mullion_with_glazing_insert_to_drywall.dxf
See also C3-036

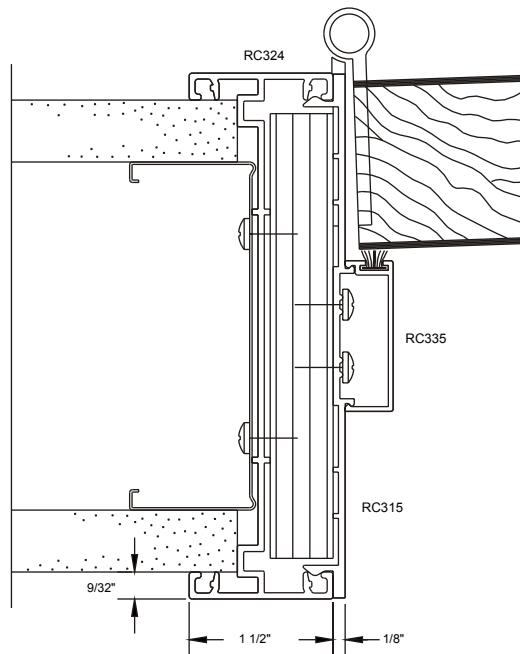

C3-050_487_vert_mullion_with_hinge_door_frame.dxf

CLASSIC Typical Details

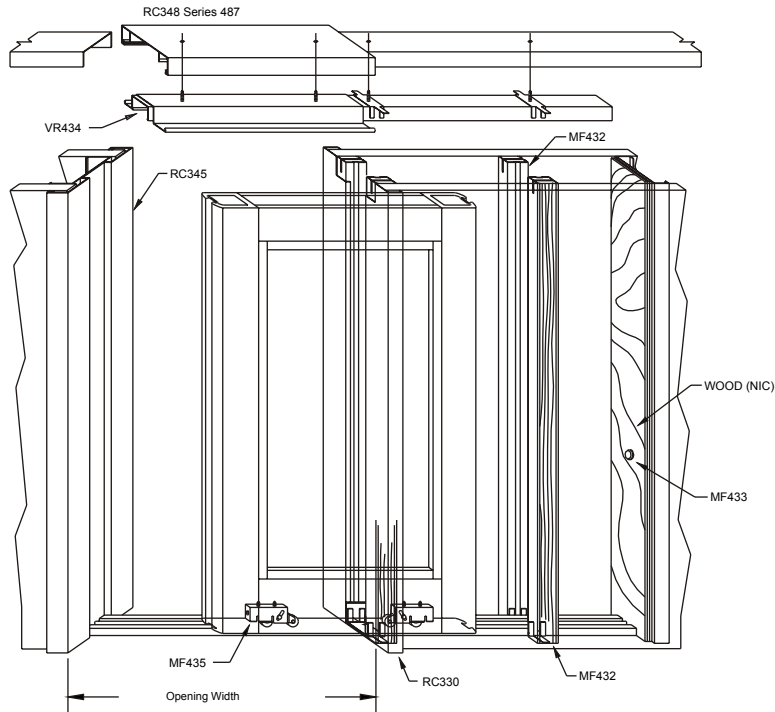

C3-051_487_pocket_door_frame_bottom_track.dxf
See also C3-021, C3-052

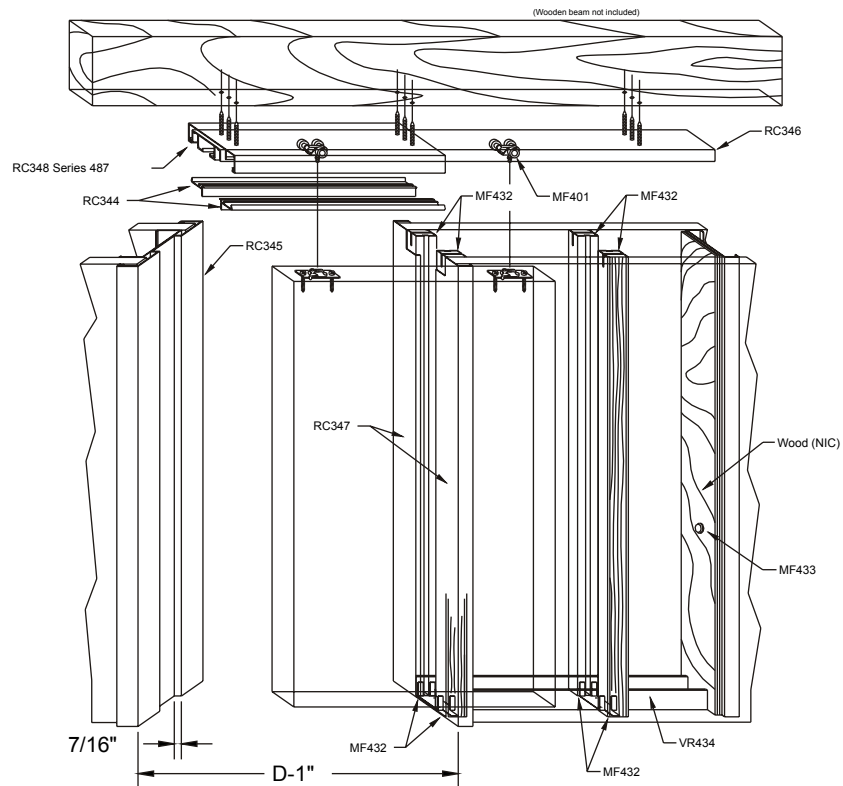

C3-052_487_pocket_door_frame_top_track.dxf
See also C3-021, C3-051

CLASSIC Typical Details

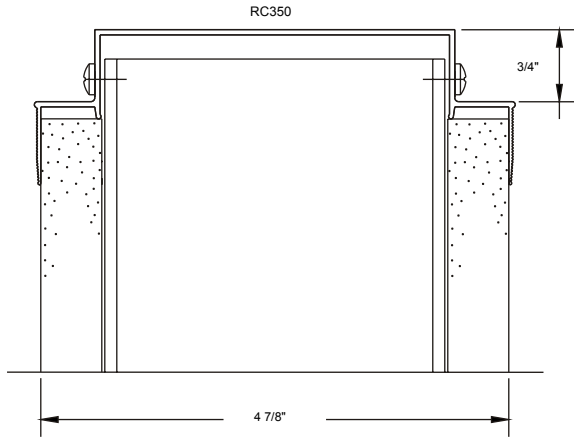

C3-053_487_recessed_reveal_header.dxf

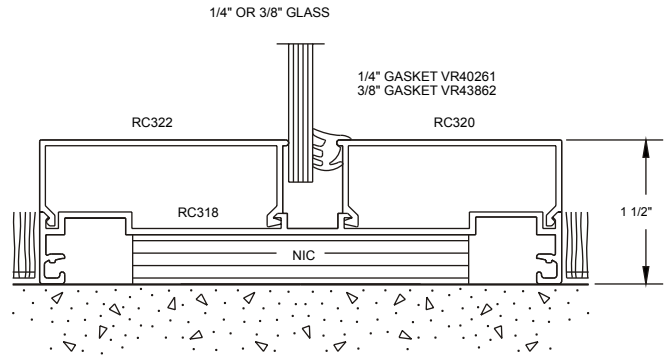

C3-055_487_sill_full_height.dxf
See also C3-056

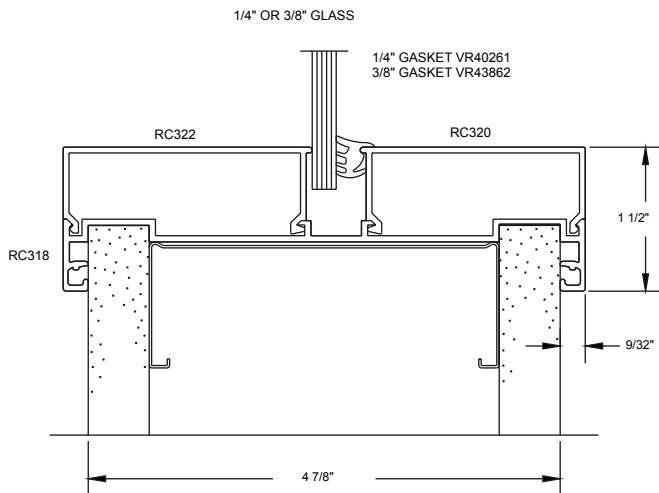

C3-056_487_sill_partial_height.dxf
See also C3-055

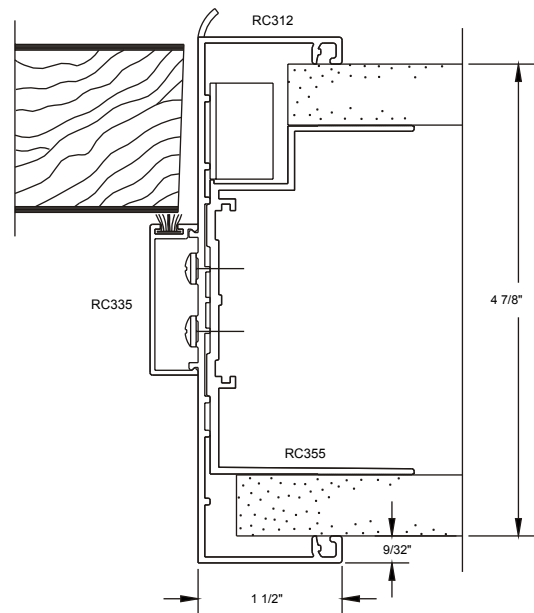

C3-057_487_strike_jamb_right_hand.dxf

CLASSIC Typical Details

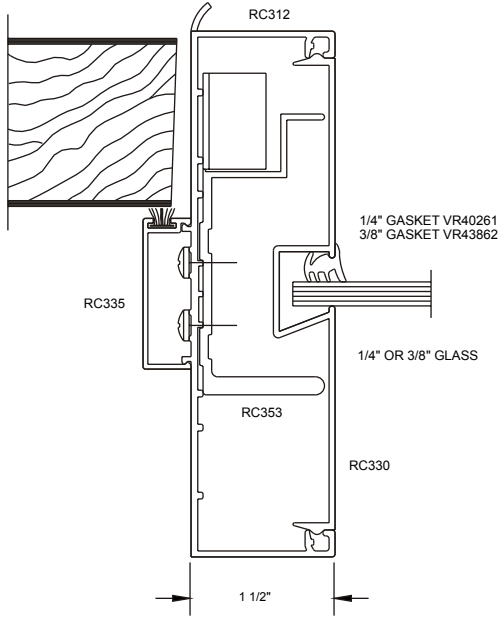

C3-058_487_strike_jamb_right_hand_with_sidelight.dxf
See also C3-044

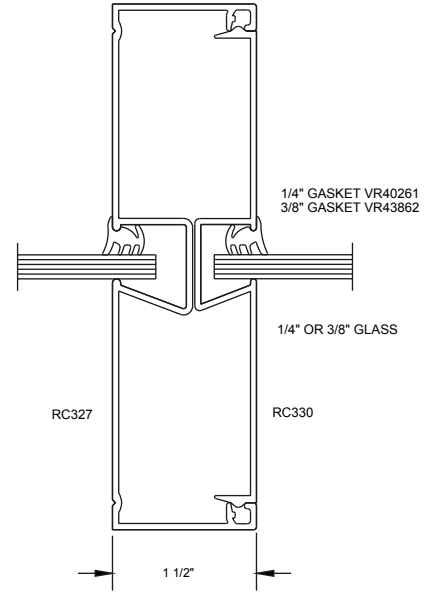

C3-059_487_vertical_mullion.dxf
See also C3-046

GUIDE SPECIFICATION

Manufacturer:
Raco Interior Products, Inc.
2000 Silber Road
Houston, Texas 77055
713 682 6100 voice
800 272 7226 toll free voice
713 682 2079 fax
www.RacoInteriors.com

**SECTION 08121
INTERIOR ALUMINUM DOORS, DOOR FRAMES, AND STOREFRONT FRAMING
(CLASSIC SYSTEM)**

This guide specification has been prepared by RACO Interior Products, Inc. in printed and electronic media, as an aid to specifiers in preparing written construction documents for interior applications for aluminum door frames, sidelight framing, storefront framing, and aluminum and glass doors.

Edit entire master to suit project requirements. Modify or add items as necessary. Delete items that are not applicable. Words and sentences within brackets [] reflect a choice to be made regarding inclusion or exclusion of a particular item or statement. This section may include performance, proprietary, and descriptive type specifications. Edit to avoid conflicting requirements. Editor notes to guide the specifier are included between lines of asterisks to assist in choices to be made. Remove these notes before final printing of specification.

This guide specification is written around the Construction Specifications Institute (CSI), Section Format standards references to section names and numbers are based on MasterFormat 95.

For specification assistance on specific product applications, please contact our offices above or any of our local product representatives throughout the country.

RACO reserves the right to modify these guide specifications at any time. Updates to this guide specification will be posted to the manufacturer's web site and/or in printed matter as they occur. RACO makes no expressed or implied warranties regarding content, errors, or omissions in the information presented.

PART 1 GENERAL

1.1 SUMMARY

A. Related Documents:

1. Provisions established within the General and Supplementary Conditions of the Contract, Division 1 _ General Requirements, and the Drawings are collectively applicable to this Section.

Edit the "Section Includes" paragraph to briefly describe the content of the section. After editing section, refer back to this paragraph to verify no conflicts occur.

CLASSIC Guide Specifications

- B. Section Includes:
 - 1. Aluminum door frames for interior use.
 - 2. [Aluminum door frames with sidelight frame components for interior use.]
 - 3. [Aluminum OfficeFronts framing system for interior use.]
 - 4. [Aluminum and glass doors for interior use.]
- C. Related Sections:
 - 1. [Section 08210 - Wood Doors.]
 - 2. [Section 08220 - Plastic Doors.]
 - 3. [Section 08710 - Door Hardware.]
 - 4. [Section 08800 - Glazing.]

1.2 SUBMITTALS

Include submittal requirements below which are consistent with the scope of the project and extent of work of this section. Only request submittals which are necessary for review of design intent.

Do not request submittals if drawings sufficiently describe the products of this section or if proprietary specifying techniques are used. The review of submittals increases the possibility of unintended variations to drawings.

- A. Submit under provisions of Section 01300.
- B. Product Data: Submit for door, sidelight and OfficeFronts frames.
 - 1. Include information for factory finish, glazing gaskets, accessories and other required components.
 - 2. Include color charts for finish indicating manufacturer's standard colors available for selection.
- C. Shop Drawings: Submit schedule indicating opening identification number, frame types, dimensions, swing, label, and hardware requirements. Use same reference numbers for openings as Contract Drawings.
- D. Include elevations and details indicating frame types, profiles, conditions at openings, methods and locations of anchoring, glazing requirements, hardware locations, and reinforcements for hardware, details of connections to special construction and other custom features.
- E. Samples: Submit following:
 - 1. Samples indicating quality of finish in selected colors on alloys used for Work.
 - 2. Where normal color and texture variations are expected, include additional samples to show range of such variation.
- F. Informational Submittals: Submit manufacturer's instructions.

1.4 QUALITY ASSURANCE

Include quality assurance requirements below that are consistent with the size and scope of the project and extent of work of this section. Only request qualification statements you intend to review, and which are necessary to establish qualifications of the product, manufacturer, or installer.

- A. Single Source Responsibility: Provide aluminum frames, aluminum and glass doors, and accessories produced by a single manufacturer for each type of product indicated.
- B. Manufacturer's Qualifications: Manufacturer shall demonstrate previous experience in manufacturing of interior aluminum door and OfficeFronts framing for a period of not less than 10 years on comparable sized project.
- C. [Fire and Smoke Rated Assemblies:
 - 1. Where fire-rated openings are scheduled or required by authorities having jurisdiction, provide fire-rated aluminum frames that have been tested and certified to meet the requirements of UBC 7.2 Positive Pressure Test for specified exposure by an agency acceptable to governing authorities.
 - 2. Provide labels permanently fastened on each fire rated frame and door that are within size limits established by NFPA and the testing authority.]

CLASSIC Guide Specifications

1.5 DELIVERY, STORAGE, AND HANDLING

- A. Deliver frames and doors in cartons to provide protection during transit and storage at project site.
- B. Inspect frames and doors upon delivery for damage.
 - 1. Repair minor damage to pre-finished products by means as recommended by manufacturer
 - 2. Replace frames and doors that cannot be satisfactorily repaired.
- C. Store frames and doors at project site under cover and as near as possible to final installation location. Do not use covering material that will cause discoloration of aluminum finish.

1.6 ENVIRONMENTAL REQUIREMENTS

- A. Do not begin installation of frames or doors until area of work has been completely enclosed and interior is protected from the elements.
- B. Maintain temperature and humidity in areas of installation within reasonable limits, as close as possible to final occupancy. If necessary, provide temperature control and ventilation to maintain required environmental conditions.

1.7 WARRANTY

- A. Warrant against defects in manufacturing of materials for a period of 2 years from date of substantial completion.
- B. Warrant framing finish against defects, including cracking, flaking, blistering, peeling, and excessive fading, chalking and non-uniformity in color for a period of 5 years.
- C. [Warrant aluminum and glass doors for life of door against corner construction failure, causing wracking of door beyond acceptable tolerances.]

PART 2 PRODUCTS

2.1 ACCEPTABLE MANUFACTURERS AND PRODUCTS

- A. Manufacturers:
 - 1. Meet or exceed standards of manufacture, appearance, performance, function, and design, of RACO Interior OfficeFronts by RACO Interior Products, Inc.
 - 2. Substitutions: Comply with provisions of Section 01600.
- B. Acceptable Products:

Select from product list below for particular project needs.

Include item 1 below if only doorframes are required. Delete items a, b, and c if fire rated doors are not required. First item 1 is for a full height (to ceiling) framing system. Second item 1 if for system less than ceiling height.

Include item 2 below if sidelights and storefront framing is required

Include item 3 below if aluminum and glass swinging doors are required

Include item 4 below if sliding aluminum and glass doors are required.

- 1. [Interior Door Frames: RACO Classic Prestige fixed throat frames to accommodate wall thicknesses indicated on Drawings; ceiling height system.]
- 1. [Interior Door Frames: RACO Classic Freestanding [fixed] [adjustable] throat frames to accommodate wall thicknesses indicated on Drawings; height of system as indicated on Drawings.
 - a. [Provide fire rated frames to [20] [90] minute rating complying with UL 10B, ASTM E152, and NFPA 252.]]
- 2. [Interior Borrowed Light and OfficeFronts Framing: RACO Classic [Prestige] [Free Standing], fixed throat frames to accommodate wall thicknesses indicated on Drawings; [ceiling height] [] height system]
- 3. [Swinging Aluminum and Glass Doors: RACO Series 550, wide stile doors, having [square] [beveled] glazing stops, and EPDM glazing gaskets, [and having ADA compliant bottom rail].

CLASSIC Guide Specifications

Select item a. below for non-fire rated doors and item b. for fire rated doors. In item c., custom mullion configurations can be specified and should be indicated on the Drawings as to type and locations. Hardware for swinging doors can be specified in e. below, or this section can be reference to Section 08710 for all hardware requirements.

- a. [Provide non-fire rated with adjustable bottom rails for field adjustment.]
- b. [Provide with 20 minute (without hose stream test) fire rated label, factory glazed with approved clear (wireless) or approved wire glass.]
- c. [Provide with custom horizontal and vertical mullion pattern as indicated on Drawings]
- d. [Provide complete with the following hardware in [] finish:
 - (1) [1-1/2] [2] pair of 4-1/2 x 4-1/2 inch [standard] [ball bearing] butts.
 - (2) Exposed overhead closer, [standard] [slim line] profile.
 - (3) [Latch] [Lock] set to match other devices in project.
 - (4) Flush bolts for inactive leaf of pairs of doors.
 - (5) Balance of hardware as indicated in Section 08710.]
- 4. [Sliding Aluminum and Glass Doors: Series 2000, Sliding Doors, complete with 2-1/16 inch stiles, 2-1/8 inch top rail, and 3-3/16 inch bottom rail.]

2.2 MATERIALS

- A. Aluminum: Meeting requirements of ASTM B221, 6063T5 alloy, and as otherwise required to assure compliance with dimensional tolerances and maintain color uniformity. Billets shall be composed of at least 33% recycled aluminum.
- B. Anchorage Devices, Clips and Fasteners: Manufacturer's standard type, compatible with materials being secured.
- C. Accessories: As necessary for complete system.

2.3 EXTRUDED ALUMINUM FRAME AND DOOR FABRICATION

- A. Assemble all sidelights and windows with the use of clips.
- B. Do not exceed maximum size of window or door to meet applicable code requirements.
- C. Factory pre-machine door frame jambs [and doors] and prepare for hardware, with concealed reinforcement plates, drilled and tapped as required, and fastened within frame with concealed screws.

2.4 FINISHES

- A. Factory finish extruded frame and door components so that all parts exposed to view upon completion of installation are uniform in finish and color. Exposed surfaces shall be free of scratches and other serious blemishes.
 - B. [Factory Applied Paint Finish: Comply with AAMA(2603)603.8 and AA-DAF-45, factory applied backed enamel coating.
 - 1. Color: [As selected from manufacturer's standard colors] [Custom color to match Architect's sample].]
 - C. Clear Anodized: AA-M12C22A21, etched, medium matte, clear anodic coating.
 - D. [Clean all aluminum surfaces of contaminants and leave ready for field painting per Section 09900.]

PART 3 EXECUTION

3.1 EXAMINATION

- A. Examine project conditions and verify that project is ready for work of this section to proceed. Do not proceed with installation until unsatisfactory conditions have been corrected.
- B. Verify wall thickness does not exceed manufacturer's recommended tolerances of specified throat size.

CLASSIC Guide Specifications

3.2 INSTALLATION

- A. Comply with frame and door manufacturer's printed installation instructions and approved shop drawings. Do not attempt installation in areas where wall thickness exceeds tolerances of specified throat size.
- B. Install frames plumb and square, free from warp or twist, securely anchored to substrates with fasteners recommended by frame manufacturer. Maintain dimensional tolerances and alignment with adjacent work. Ensure joints are hairline tight and surfaces flush with adjacent components.
- C. Set all doors in correct locations as shown on the drawings, level, square, plumb and in alignment with other work in accordance with the manufacturer's installation instructions and approved shop drawings.
- D. [Install glass in accordance with Section 08800.]

3.3 ADJUSTING AND CLEANING

- A. Protect exposed portions of aluminum surfaces from damage by plaster, lime, acid, cement, and other contaminants.
- B. Touch up marred areas so that touch-up is not visible from a distance of 4 feet. Remove and replace frames that cannot be satisfactorily adjusted.

3.4 PROTECTION

- A. Protect as required to assure that frames and doors will be without damage until Substantial Completion.

END OF SECTION