

Notebook Computer

M400A / M40AE / M400G / M40GE

Service Manual

Notice

The company reserves the right to revise this publication or to change its contents without notice. Information contained herein is for reference only and does not constitute a commitment on the part of the manufacturer or any subsequent vendor. They assume no responsibility or liability for any errors or inaccuracies that may appear in this publication nor are they in anyway responsible for any loss or damage resulting from the use (or misuse) of this publication.

This publication and any accompanying software may not, in whole or in part, be reproduced, translated, transmitted or reduced to any machine readable form without prior consent from the vendor, manufacturer or creators of this publication, except for copies kept by the user for backup purposes.

Brand and product names mentioned in this publication may or may not be copyrights and/or registered trademarks of their respective companies. They are mentioned for identification purposes only and are not intended as an endorsement of that product or its manufacturer.

Version 1.0
May 2005

Trademarks

Intel® and **Pentium®** are US registered trademarks of Intel Corporation.

 is a trademark of SRS Labs, Inc. **WOW** technology is incorporated under license from SRS Labs, Inc.

Windows® is a registered trademark of Microsoft Corporation.

Other brand and product names are trademarks and./or registered trademarks of their respective companies.

About this Manual

This manual is intended for service personnel who have completed sufficient training to undertake the maintenance and inspection of personal computers.

It is organized to allow you to look up basic information for servicing and/or upgrading components of the *M400A/M400G/M40AE/M40GE* series notebook PC.

The following information is included:

Chapter 1, Introduction, provides general information about the location of system elements and their specifications.

Chapter 2, Disassembly, provides step-by-step instructions for disassembling parts and subsystems and how to upgrade elements of the system.

Appendix A, Part Lists

Appendix B, Schematic Diagrams

Appendix C, Switches

IMPORTANT SAFETY INSTRUCTIONS

Follow basic safety precautions, including those listed below, to reduce the risk of fire, electric shock and injury to persons when using any electrical equipment:

1. Do not use this product near water, for example near a bath tub, wash bowl, kitchen sink or laundry tub, in a wet basement or near a swimming pool.
2. Avoid using a telephone (other than a cordless type) during an electrical storm. There may be a remote risk of electrical shock from lightning.
3. Do not use the telephone to report a gas leak in the vicinity of the leak.
4. Use only the power cord and batteries indicated in this manual. Do not dispose of batteries in a fire. They may explode. Check with local codes for possible special disposal instructions.
5. This product is intended to be supplied by a Listed Power Unit (**M400A/M40AE** by a DC Output 20V, 4.5A minimum AC Adapter and **M400G/M40GE** by a DC Output 20V, 3.25A minimum AC Adapter - see *"Power" on page 1 - 6*).

CAUTION

Always disconnect all telephone lines from the wall outlet before servicing or disassembling this equipment.

**TO REDUCE THE RISK OF FIRE, USE ONLY NO. 26 AWG OR LARGER,
TELECOMMUNICATION LINE CORD**

This Computer's Optical Device is a Laser Class I Product

Instructions for Care and Operation

The notebook computer is quite rugged, but it can be damaged. To prevent this, follow these suggestions:

1. **Don't drop it, or expose it to shock.** If the computer falls, the case and the components could be damaged.



2. **Keep it dry, and don't overheat it.** Keep the computer and power supply away from any kind of heating element. This is an electrical appliance. If water or any other liquid gets into it, the computer could be badly damaged.

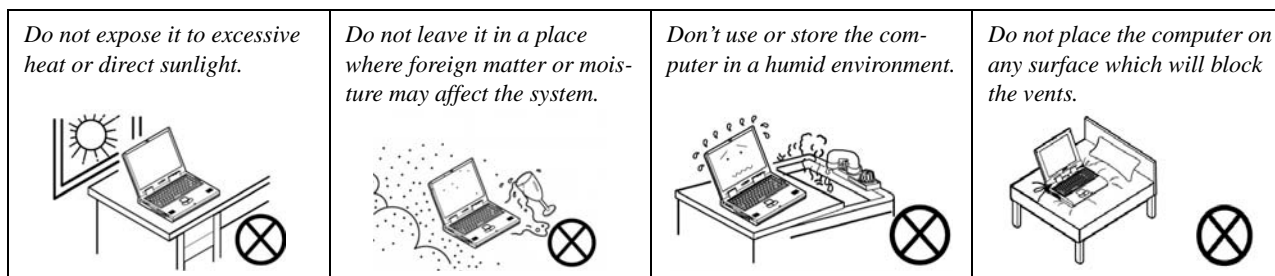

3. **Follow the proper working procedures for the computer.** Shut the computer down properly and don't forget to save your work. Remember to periodically save your data as data may be lost if the battery is depleted.

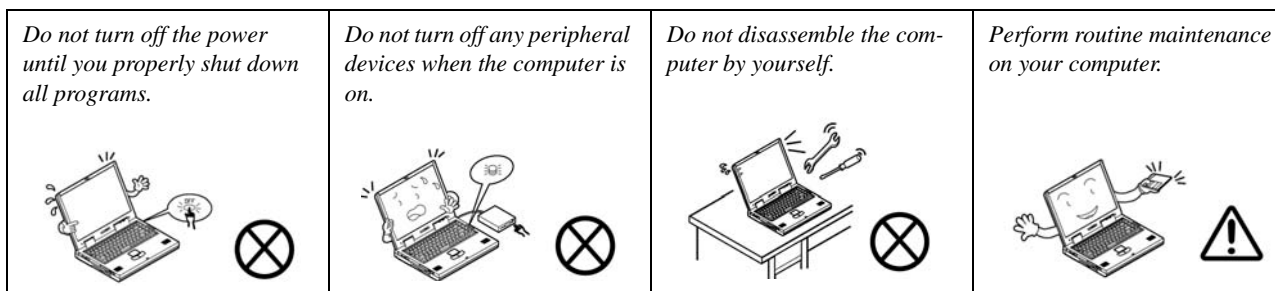

4. **Avoid interference.** Keep the computer away from high capacity transformers, electric motors, and other strong magnetic fields. These can hinder proper performance and damage your data.
5. **Take care when using peripheral devices.**

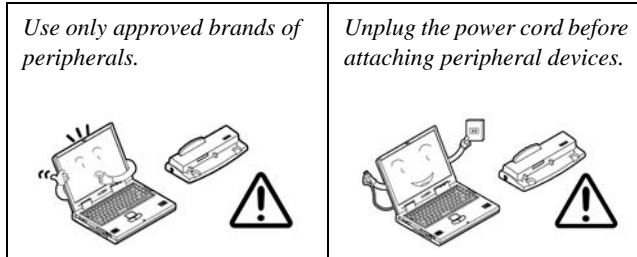

Power Safety

The computer has specific power requirements:

- Only use a power adapter approved for use with this computer.
- Your AC adapter may be designed for international travel but it still requires a steady, uninterrupted power supply. If you are unsure of your local power specifications, consult your service representative or local power company.
- The power adapter may have either a 2-prong or a 3-prong grounded plug. The third prong is an important safety feature; do not defeat its purpose. If you do not have access to a compatible outlet, have a qualified electrician install one.
- When you want to unplug the power cord, be sure to disconnect it by the plug head, not by its wire.
- Make sure the socket and any extension cord(s) you use can support the total current load of all the connected devices.
- Before cleaning the computer, make sure it is disconnected from any external power supplies.

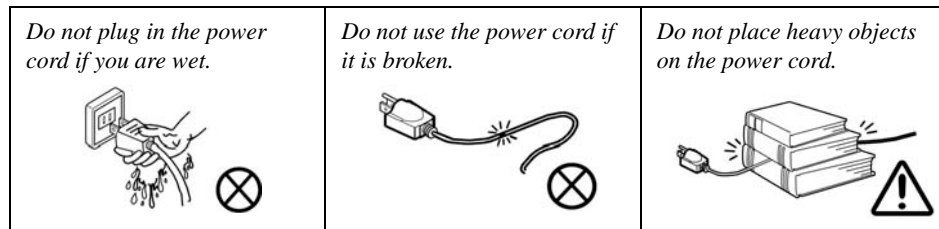

Power Safety Warning

Before you undertake any upgrade procedures, make sure that you have turned off the power, and disconnected all peripherals and cables (including telephone lines). It is advisable to also remove your battery in order to prevent accidentally turning the machine on.

Battery Precautions

- Only use batteries designed for this computer. The wrong battery type may explode, leak or damage the computer.
- Recharge the batteries using the notebook's system. Incorrect recharging may make the battery explode.
- Do not try to repair a battery pack. Refer any battery pack repair or replacement to your service representative or qualified service personnel.
- Keep children away from, and promptly dispose of a damaged battery. Always dispose of batteries carefully. Batteries may explode or leak if exposed to fire, or improperly handled or discarded.
- Keep the battery away from metal appliances.
- Affix tape to the battery contacts before disposing of the battery.
- Do not touch the battery contacts with your hands or metal objects.



Battery Disposal

The product that you have purchased contains a rechargeable battery. The battery is recyclable. At the end of its useful life, under various state and local laws, it may be illegal to dispose of this battery into the municipal waste stream. Check with your local solid waste officials for details in your area for recycling options or proper disposal.

Caution

Danger of explosion if battery is incorrectly replaced. Replace only with the same or equivalent type recommended by the manufacturer. Discard used battery according to the manufacturer's instructions.

Related Documents

You may also need to consult the User's Manual on CD as this describes the notebook PC's features, the procedures for operating the computer, and its ROM-based setup program. It also describes the installation and operation of the utility programs provided with the notebook PC.

Contents

Introduction1-1

Overview	1-1
Model Differences	1-2
Specifications	1-3
Processor	1-3
Core Logic	1-3
Memory	1-4
Security	1-4
BIOS	1-4
LCD Options	1-4
Video Adapter	1-4
Storage	1-5
Audio	1-5
Keyboard & Pointing Device	1-5
PCMCIA	1-5
Interface	1-5
Card Reader	1-5
Communication	1-5
Power Management	1-5
Power	1-6
Environmental Spec	1-6
Physical Dimensions & Weight	1-6
Optional	1-6
External Locator - Top View with LCD Panel Open	1-7
External Locator - Front & Rear Views	1-8
External Locator - Right Side & Left Side Views	1-9
External Locator - Bottom View	1-10
Mainboard Overview - Top (Key Parts)	1-11
Mainboard Overview - Bottom (Key Parts)	1-12

Mainboard Overview - Top (Connectors)	1-13
Mainboard Overview - Bottom (Connectors)	1-14

Disassembly2-1

Overview	2-1
Maintenance Tools	2-2
Connections	2-2
Maintenance Precautions	2-3
Cleaning	2-3
Disassembly Steps	2-4
Removing the Battery	2-5
Removing the Hard Disk Drive	2-6
Changing Serial and Parallel Hard Disk Cables	2-8
Upgrading the System Memory (RAM)	2-9
Removing the Optical (CD/DVD) Device	2-11
Removing the Processor	2-12
Removing the Modem	2-14
Removing the Wireless LAN Module	2-15
Removing the Keyboard	2-16
Removing the Keyboard Shielding Plate	2-17
Removing the PCI Express VGA Card	2-18

Part ListsA-1

Part List Illustration Location	A-2
Top (M400A/M40AE/M400G/M40GE)	A-3
Bottom (M400A)	A-4
Bottom (M400AE)	A-5
Bottom (M400G)	A-6
Bottom (M400GE)	A-7

Preface

LCD (M400A/M40AE/M400G/M40GE)	A-8
CD-ROM Drive - SAMSUNG (M400A/M40AE/M400G/M40GE)	A-9
Combo Drive - QSI (M400A/M40AE/M400G/M40GE)	A-10
Combo Drive - TEAC (M400A/M40AE/M400G/M40GE)	A-11
DVD-DUALRW Drive - LITEON (M400A/M40AE/M400G/M40GE)	A-12
DVD-DUALRW Drive - PIONEER (M400A/M40AE/M400G/M40GE)	A-13
DVD Drive - QSI (M400A/M40AE/M400G/M40GE)	A-14
Hard Disk Drive (M400A/M40AE/M400G/M40GE)	A-15

Schematic Diagrams..... B-1

System Block Diagram	B-2
CLOCK GENERATOR	B-3
CPU - 1	B-4
CPU - 2	B-5
ALVISO - 1	B-6
ALVISO - 2	B-7
ALVISO - 3	B-8
ALVISO - 4	B-9
VGA CARD CONNECTOR	B-10
DDR2 - DIMM1	B-11
DDR2 - DIMM2	B-12
ICH6 - 1	B-13
ICH6 - 2	B-14
ICH6 - 3	B-15
HDD & CD ROM	B-16
USB & CCD CONN	B-17
MDC, BT, CCD	B-18
PCI-E LAN	B-19
TI - 1394A (43AB21)	B-20

CON; MINIPCI	B-21
PCMCIA (1620)	B-22
PCMCIA SOCKET	B-23
HITACHI H8	B-24
AUDIO	B-25
+VS; PWRBTN	B-26
LED; NS87383	B-27
FAN CONN, LPC ROM	B-28
5V, 3.3V, +1.5V	B-29
CHARGER	B-30
TPS51116	B-31
VCORE+ 1.05V	B-32
CARD READER BOARD	B-33
CLICK BOARD	B-34
LED BOARD	B-35
RJ11 BOARD	B-36
SRS AP8202	B-37

Switches C-1

Locating the Jumper Switch	C-1
Settings	C-2
CPU Clock Setup (Switch SW1)	C-2

Introduction

Overview

This manual covers the information you need to service or upgrade the *M400A/M400G/M40AE/M40GE* series notebook computer. Information about operating the computer (e.g. getting started, and the *Setup* utility) is in the *User's Manual*. Information about drivers (e.g. VGA & audio) is also found in *User's Manual*. That manual is shipped with the computer.

Operating systems (e.g. *DOS*, *Windows 9x*, *Windows NT 4.0*, *Windows 2000*, *Windows XP*, *OS/2 Warp*, *UNIX*, etc.) have their own manuals as do application software (e.g. word processing and database programs). If you have questions about those programs, you should consult those manuals.

The *M400A/M400G/M40AE/M40GE* series notebook is designed to be upgradeable. See *“Disassembly” on page 2 - 1* for a detailed description of the upgrade procedures for each specific component. Please note the warning and safety information indicated by the “” symbol.

The balance of this chapter reviews the computer's technical specifications and features.

Model Differences

This notebook series includes **four** different model types. The models differ in video support, system memory (RAM) supported, and AC adapter supplied. Models **M400A & M40AE** include **ATI X700 (ATI M26)** PCI Express video cards, models **M400G & M40GE** include built-in **Intel (Intel GMA 900)** video. Models **M400A & M40AE** are supplied with a **90W** power adapter, models **M400G & M40GE** are supplied with a **65W** power adapter. Models **M400A & M400G** support **DDR RAM**; models **M40AE & M40GE** support **DDRII (DDR2)** RAM.

Feature	M400A	M40AE	M400G	M40GE
Video Adapter	ATI X700 PCI Express Video Card		Intel GMA 900 On-Board	
Power Adapter	90W		65W	
RAM (Memory) Supported	DDR	DDRII (DDR2)	DDR	DDRII (DDR2)

Table 1 - 1
Model Differences



RAM Modules Supported

If you need to upgrade or replace the memory (RAM) modules, make sure you are using the appropriate module type for the computer.

Specifications



Latest Specification Information

The specifications listed in this Appendix are correct at the time of going to press. Certain items (particularly processor types/speeds and CD/DVD device types) may be changed or updated due to the manufacturer's release schedule. Check with your service center for details.

Table 1 - 2
Specifications

Feature	Specification	
Processor	Intel Pentium® M Processor (478-pin) Micro-FC-PGA Package Models 730/ 740/ 750/ 760/ 770	(μ0.09) 0.09 Micron Process Technology 2MB On-die L2 Cache & 533MHz FSB 1.6/ 1.73/ 1.86/ 2/ 2.13 GHz
	Intel Pentium® M Processor (478-pin) Micro-FCPGA Package	(μ0.13) 0.13 Micron Process Technology 1MB On-die L2 Cache & 400MHz FSB 1.3/ 1.4/ 1.5/ 1.6/ 1.7 GHz
	Intel Pentium® M Processor (478-pin) Micro-FC-PGA Package Models 725/ 735/ 745/ 755	(μ0.09) 0.09 Micron Process Technology 2MB On-die L2 Cache & 400MHz FSB 1.6 / 1.7/ 1.8/ 2.0 GHz
	Intel Celeron® M Processor (478-pin) Micro-FCPGA Package Models 320/ 330/ 340	(μ0.13) 0.13 Micron Process Technology 512KB On-die L2 Cache & 400MHz FSB 1.3/ 1.4/ 1.5 GHz
	Intel Celeron® M Processor (478-pin) Micro-FCPGA Package Models 350/ 360/ 370	(μ0.09) 0.09 Micron Process Technology 1MB On-die L2 Cache & 400MHz FSB 1.3/ 1.4/ 1.5 GHz
Core Logic	Intel 915PM + ICH6-M (Models M400A & M40AE) Intel 915GM + ICH6-M (Models M400G & M40GE)	

Introduction

Feature	Specification	
Memory	<p>Models M400A & M400G Two SO-DIMM Sockets Supporting DDR Memory Single Channel Speed up to 333 MHz (Note: Do Not Use Other Module Types) Memory Expandable up to 2GB (128/ 256/ 512/ 1024 MB DDR Modules)</p>	<p>Models M40AE & M40GE: Two SO-DIMM Sockets Supporting DDRII (DDR2) Memory Dual Channel Speed up to 533 MHz (Note: Do Not Use Other Module Types) Memory Expandable up to 2GB (128/ 256/ 512/ 1024 MB DDRII Modules)</p> <div data-bbox="958 544 1951 868" style="border: 2px solid red; border-radius: 15px; padding: 10px; text-align: center;">  RAM Modules Supported <p>If you intend to upgrade or replace your memory (RAM) modules, make sure you are using the appropriate module type for your computer. Model M400A & M400G computers support DDR RAM modules; Model M40AE & M40GE computers support DDRII (DDR2) RAM modules. These types of RAM modules are not interchangeable, and they differ in size very slightly. If you are unsure which module type your computer supports then consult your service center.</p> </div>
Security	Security (Kensington® Type) Lock Slot	
BIOS	One 512KB Flash ROM	Phoenix BIOS, Plug and Play
LCD Options	15.0" XGA Flat Panel TFT (1024*768)	15.0" SXGA Flat Panel TFT (1400 * 1050)
Video Adapter	<p>Models M400A & M40AE: ATI M26(X700) PCI-E 16X 128MB/256MB(M26) DDR-DRAM Pure Hardware DirectX 9 128-bit Memory Interface</p>	<p>Models M400G & M40GE: Intel® Graphics Media Accelerator 900 (Intel® GMA 900) Dynamic Video Memory Technology DVMT 3.0 - Supports up to 224MB of Video Memory (dynamically allocated from system memory where needed) Supports Dual Independent Displays Motion Compensation for Smooth DVD Playback</p>

Feature	Specification	
Storage	One Changeable 12.7mm(h) Optical Device (CD/DVD) Type Drive (see "Optional" on page 1 - 6 for drive options) Easy Changeable 2.5" 9.5 mm (h) IDE HDD Supports PATA (Parallel) / SATA (Serial) HDDs. Supporting ATA 100/66/33 or SATA 1.5G	
Audio	7.1 Channel High Definition Audio Codecs with UAA (Universal Audio Architecture) EAX™ 1.0 & 2.0 Compatible Direct Sound™ 3D Compatible I3DL2 Compatible	A3D™ Compatible 16/20/24-bit S/PDIF-OUT Supporting 44.1/48/96kHz Sample Rates Built-In 2 Hi-Fi Speakers (Factory Option) SRS WOW Surround Sound (3D Surround\ True Bass\ Focus Enhancement)
Keyboard & Pointing Device	Winkey Keyboard	Built-In TouchPad with Scrolling Function
PCMCIA	One Type-II PCMCIA CardBus PC Card Slot	
Interface	Four USB 2.0 Ports One Mini-IEEE 1394 Port One External Monitor Port One Parallel Port (LPT1) Supporting ECP/EPP One S/PDIF Output Jack One S-Video-Out Port One Infrared Transceiver	One Headphone-Out Jack One Microphone-In Jack One Line-In Jack One RJ-11 Jack for Plug & Play Fax/Modem One RJ-45 Jack for 10M/100M/1000M Fast Ethernet One DC-in Jack
Card Reader	Embedded 3-in-1 Card Reader (MS/ SD/ MMC)	
Communication	56K Plug & Play Fax/Modem v.90/92 Compliant 1Gbit PCI-Express Fast Ethernet Card (Option) Intel® PRO/Wireless 2200BG Mini PCI Wireless LAN Module (Option) Intel® PRO/Wireless 2915ABG Mini PCI Wireless LAN Module (Factory Option) Bluetooth Version 1.2 with Azalia Modem Combo (Factory Option) PC Camera with USB Interface	
Power Management	Supports ACPI 2.0 Power Button as Sleep/Resume Key Supports Hibernate Mode Supports Standby	Supports Battery Low Suspend Supports Resume from Alarm Time Supports Resume from Modem Ring Supports Wake on LAN

Introduction

Feature	Specification	
Power	Models M400A & M40AE - AC Adapter: Full Range AC Adapter 90W 100~240V, 47~63Hz 6 Cell Smart Lithium-Ion Battery Pack, 4.4AH 12 Cell Smart Lithium-Ion Battery Pack, 6.6AH (Optional)	Models M400G & M40GE - AC Adapter: Full Range AC Adapter 65W 100~240V, 47~63Hz
Environmental Spec	Temperature Operating: 5°C ~ 35°C Non-Operating: -20°C ~ 60°C	Relative Humidity Operating: 20% ~ 80% Non-Operating: 10% ~ 90%
Physical Dimensions & Weight	329mm (w) * 275mm (d) * 25-37mm (h) Min Models M400A & M40AE: 3.2 kg With 6 cell Battery	
Optional	Optical Drive Module Options: CD-ROM Drive Module Combo Drive Module DVD-ROM Drive Module DVD-Dual Drive Module 6 Cell Smart Lithium-Ion Battery Pack, 4.4AH 12 Cell Smart Lithium-Ion Battery Pack, 6.6AH PC Camera with USB Interface	Wireless LAN Module Options: Intel® PRO/Wireless 2200BG Mini-PCI Wireless LAN Module Intel® PRO/Wireless 2915ABG Mini-PCI Wireless LAN Module Bluetooth Version 1.2 with Azalia Modem Combo Roxio CD Creator Software Power DVD 6.0 Software

External Locator - Top View with LCD Panel Open

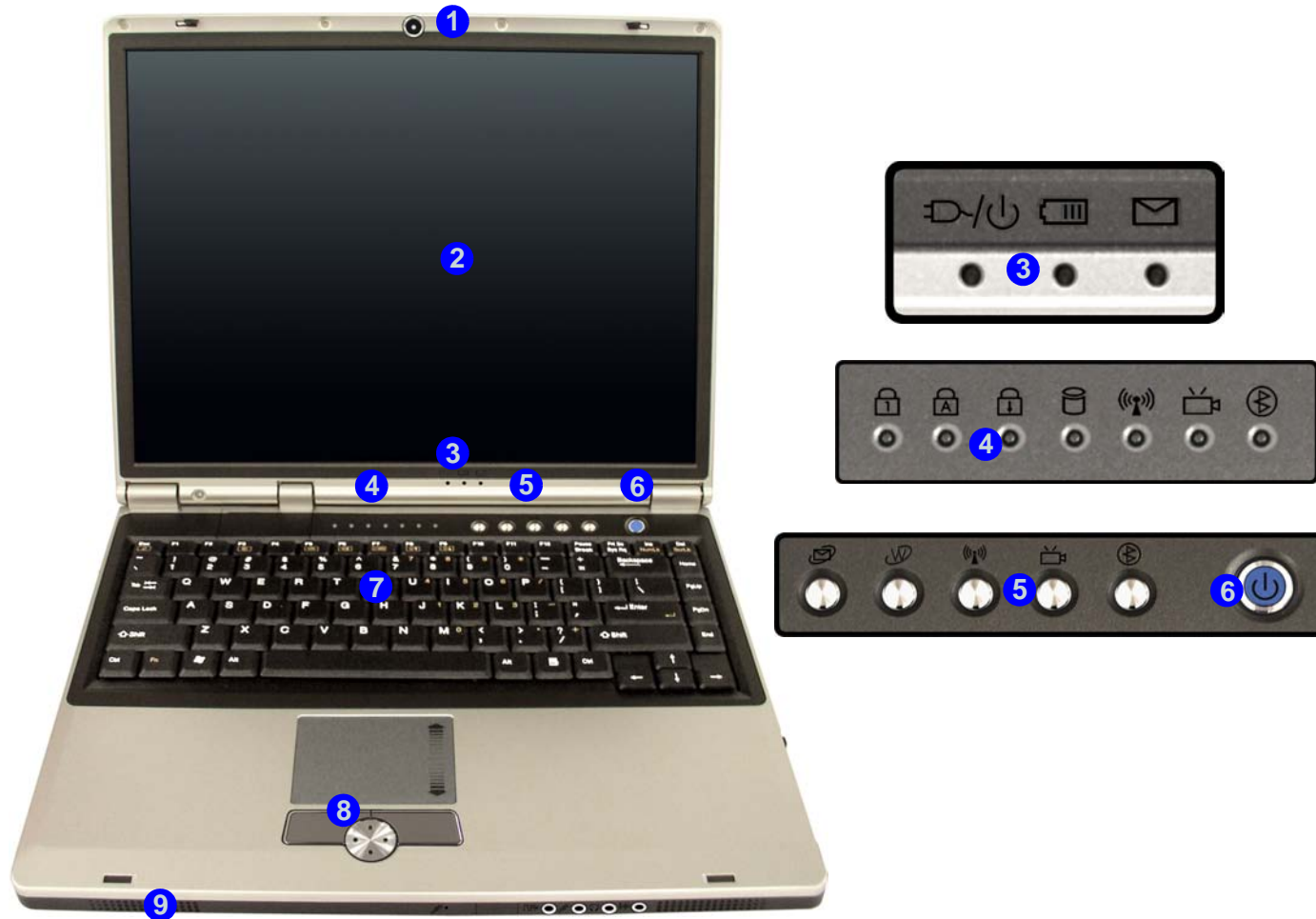

Figure 1 - 1
Top View

1. Optional Built-In PC Camera
2. LCD
3. LED Power & Communication Indicators
4. LED Status Indicators
5. Quick-Key Button
6. Power Button
7. Keyboard
8. TouchPad and Buttons
9. Speakers

Introduction

Figure 1 - 2
Front View

1. LCD Latches
2. Speaker
3. Built-In
Microphone
4. S/PDIF-Out
Jack
5. Microphone-In
Jack
6. Headphone-Out
Jack
7. Line-In Jack

External Locator - Front & Rear Views



Figure 1 - 3
Rear View

1. Vent
2. DC-In Jack
3. Security Lock Slot
4. Parallel Port
5. 2 * USB 2.0 Ports



External Locator - Right Side & Left Side Views



Figure 1 - 4
Right Side View

1. Optical Device Drive Bay
2. PC Card Slot
3. 4-in-1 Card Reader (reads SD/ MMC/ MS & MS Pro formats)
4. RJ-11 Phone Jack



Figure 1 - 5
Left Side View

1. RJ-45 LAN Jack
2. S-Video-Out Jack
3. External Monitor (VGA) Port
4. Mini-IEEE 1394a Port
5. 2 * USB 2.0 Ports



External Locator - Bottom View

Figure 1 - 6
Bottom View

1. Vent/Fan Intakes
2. Modem/
Bluetooth &
Modem Combo
Module Cover
3. CPU Bay Cover
4. Hard Disk/
Memory (RAM)/
WLAN Cover
5. Battery

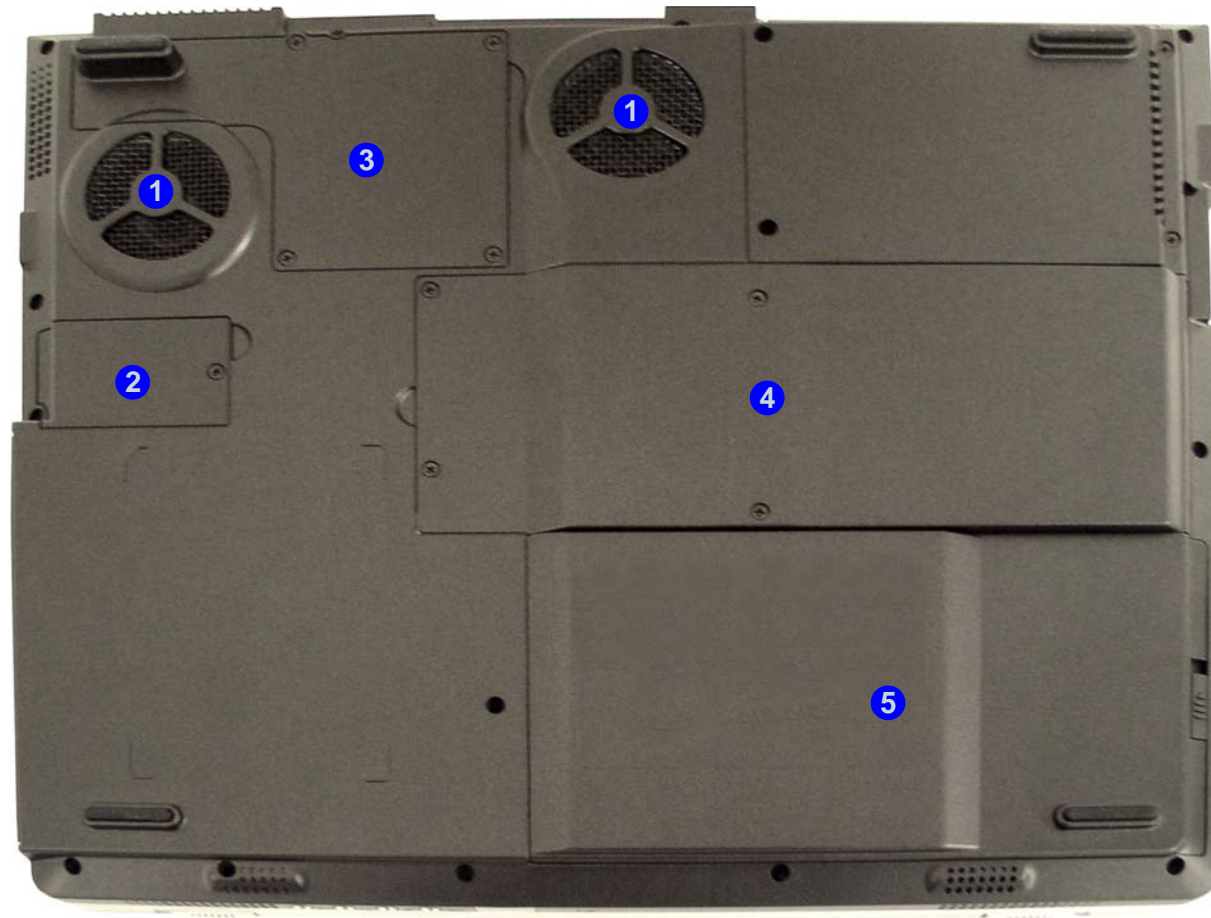

Overheating

To prevent your computer from overheating make sure nothing blocks the vent/fan intakes while the computer is in use.

Mainboard Overview - Top (Key Parts)

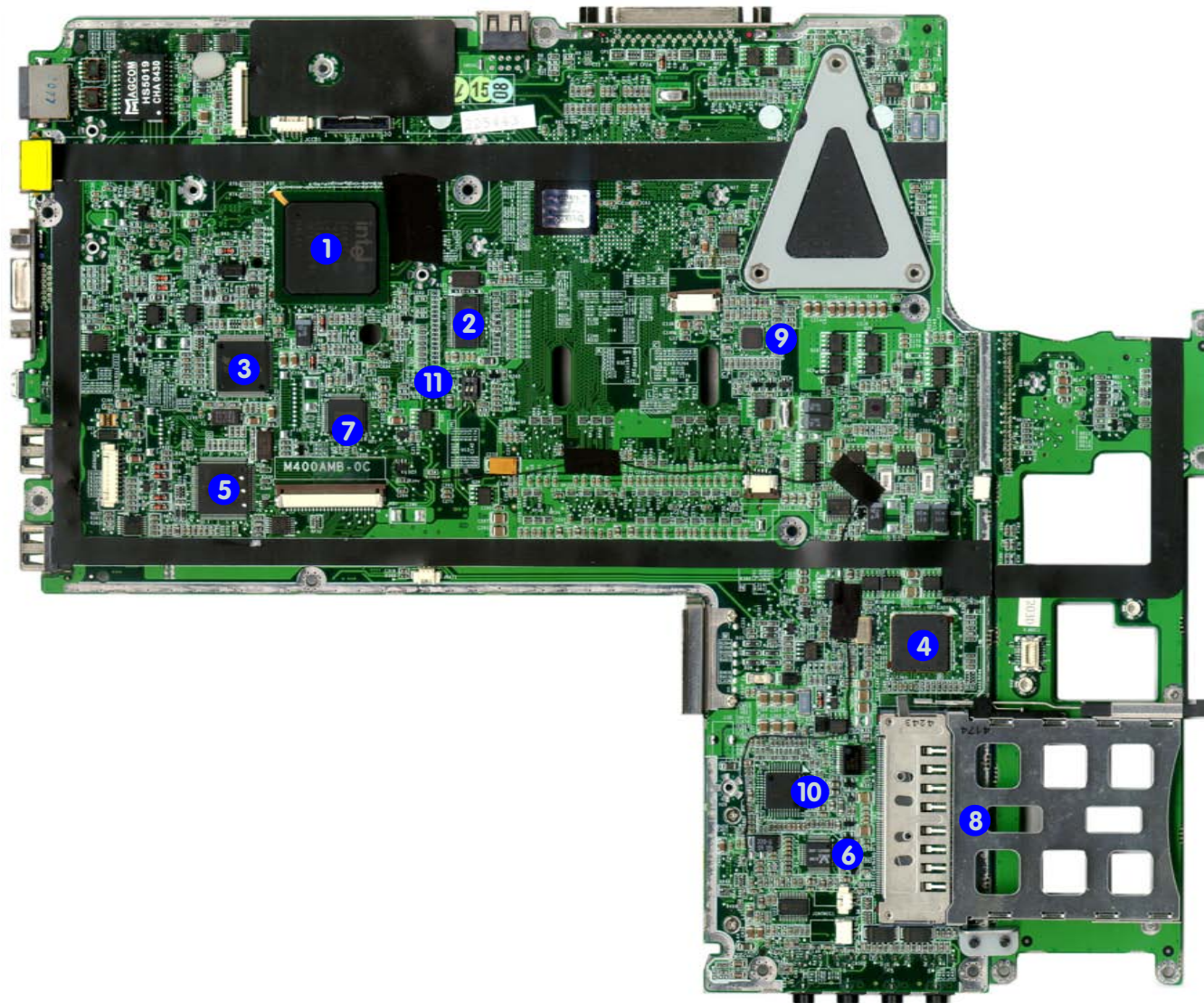

Figure 1 - 7
Mainboard Top
Key Parts

1. ICH6-M I/O Controller Hub
2. Clock Generator
3. TI - 1394A (43AB21)
4. PCMCIA (1620)
5. Hitachi H8
6. Audio - ALC880
7. LED; NS87383
8. TPS51116
9. VCORE+ 1.05V
10. SRS AP8202
11. DIP Switch (see *"Switches"* on page C - 1)

Introduction

Figure 1 - 8
**Mainboard Bottom
Key Parts**

1. CPU Socket (no CPU installed)
2. Memory Slots (M40AE & M40GE Support DDR2 Memory Modules)
3. Alviso 915PM (located under the fan unit)
4. Flash BIOS ROM

Mainboard Overview - Bottom (Key Parts)

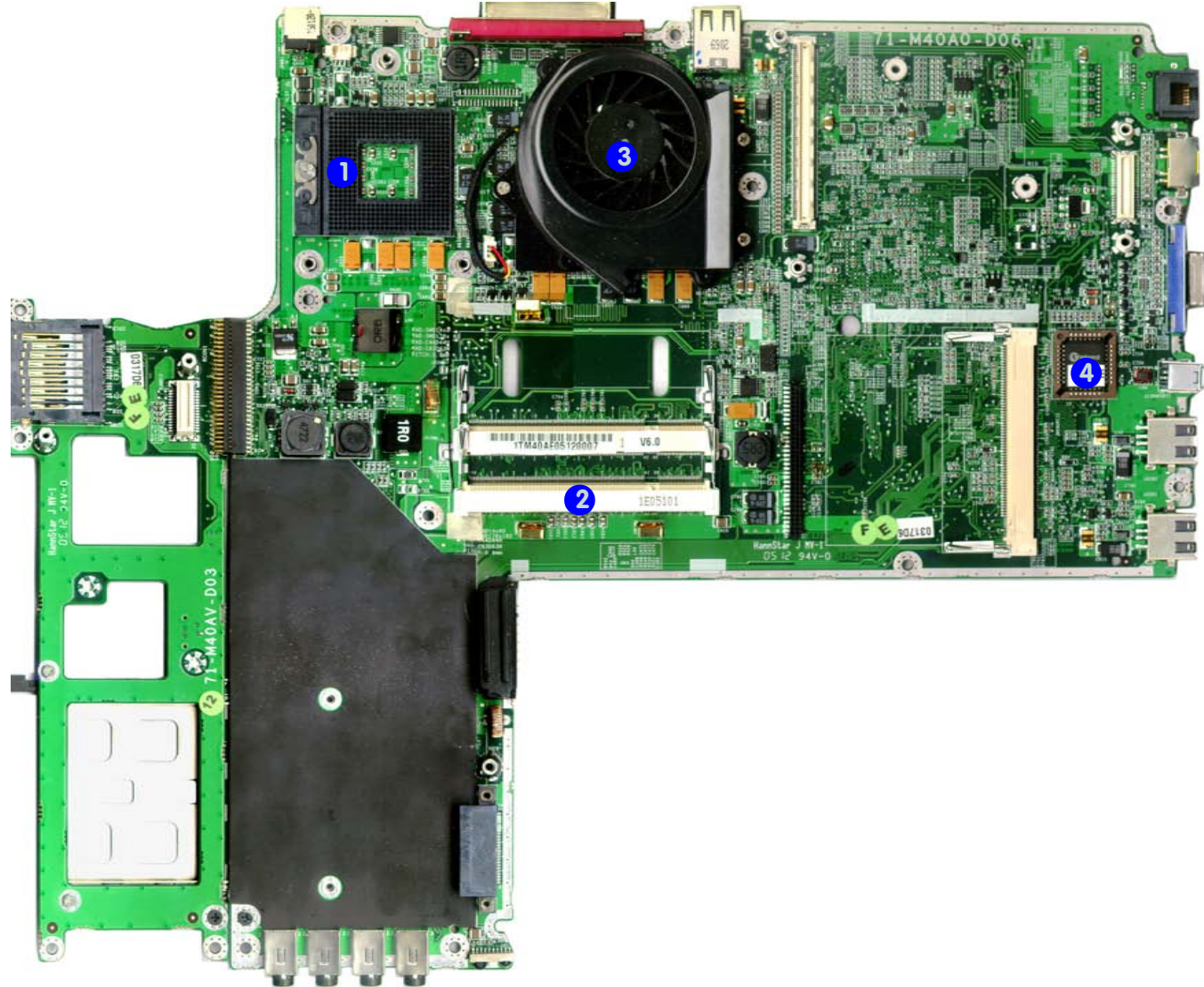

Mainboard Overview - Top (Connectors)

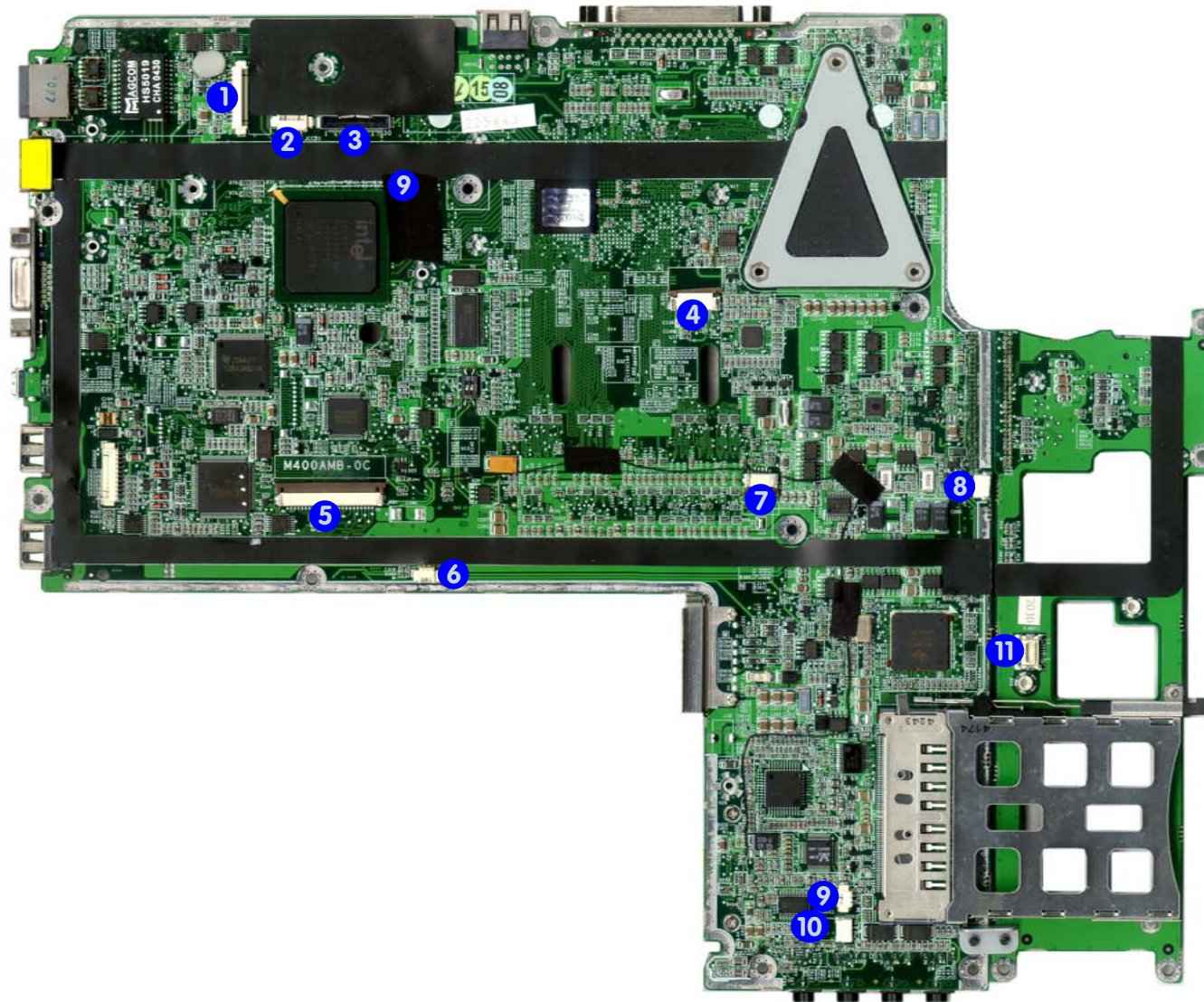

Figure 1 - 9
**Mainboard Top
Connectors**

1. Inverter (JINV1)
2. Camera (JCCD1)
3. LCD (JLCD1)
4. LED (JLED1)
5. Keyboard (JKB1)
6. CMOS Battery Cable (JBAT1)
7. TouchPad (JTP1)
8. Speaker (JSPK1)
9. Microphone Cable (JINTMIC1)
10. Speaker (JSPK2)
11. Modem (RJMDC1)

Introduction

Figure 1 - 10
**Mainboard Bottom
Connectors**

1. VGA Card Connectors (CON1 & CON2) - **M400A & M400AE Only**
2. Hard Disk (JHDD1)
3. Mini-PCI Connector (JMINIPC1)
4. Fan (JFAN1)
5. Modem (MDC2)
6. Fan (JFAN2)
7. Battery
8. CD/DVD Optical Device (JCD1)

Mainboard Overview - Bottom (Connectors)

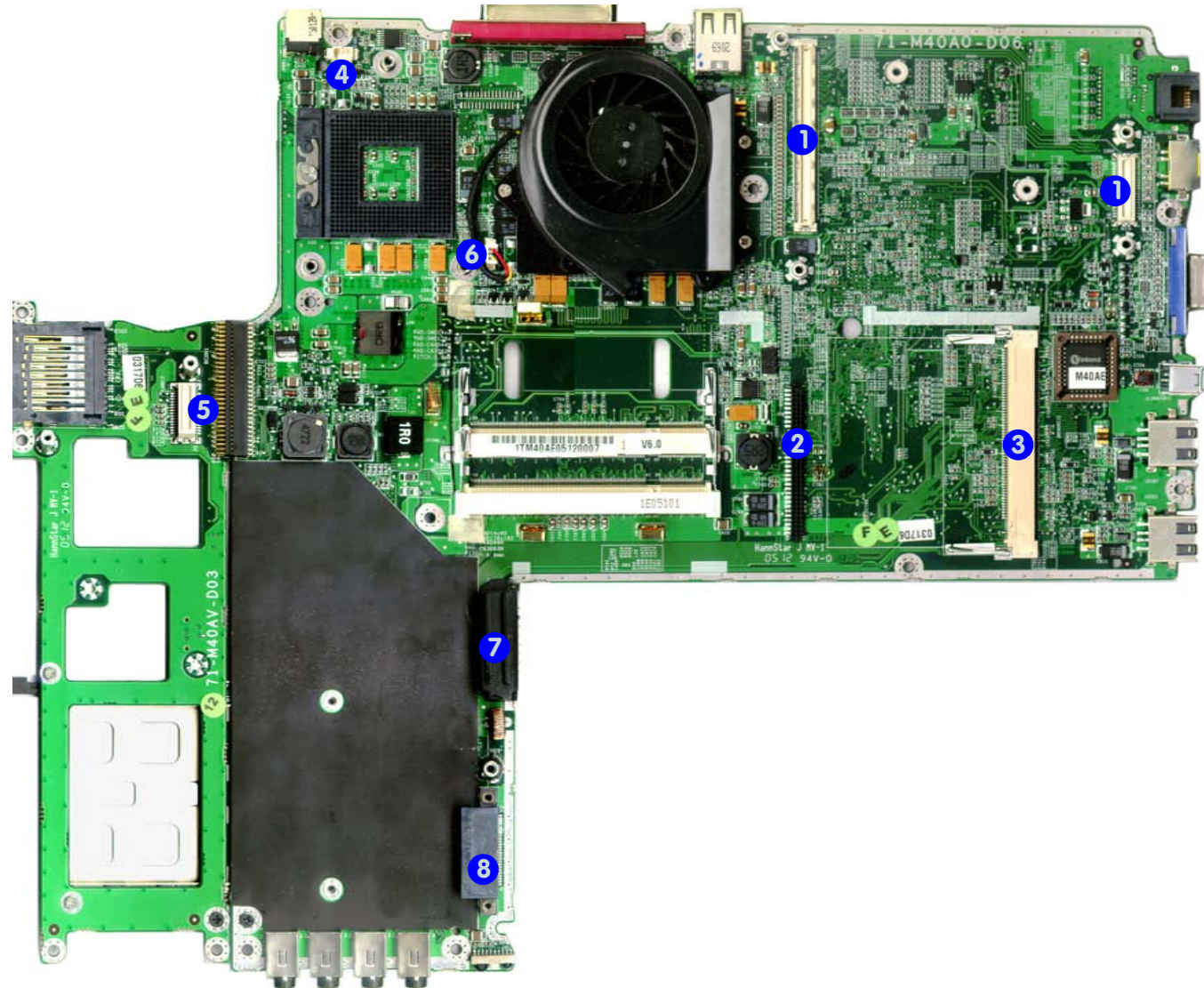

2: Disassembly



Overview

This chapter provides step-by-step instructions for disassembling the *M400A/M400G/M40AE/M40GE* series notebook's parts and subsystems. When it comes to reassembly, reverse the procedures (unless otherwise indicated).

We suggest you completely review any procedure before you take the computer apart.

Procedures such as upgrading/replacing the RAM, CD device and hard disk are included in the User's Manual but are repeated here for your convenience.

To make the disassembly process easier each section may have a box in the page margin. Information contained under the figure # will give a synopsis of the sequence of procedures involved in the disassembly procedure. A box with a  lists the relevant parts you will have after the disassembly process is complete. **Note:** The parts listed will be for the disassembly procedure listed ONLY, and not any previous disassembly step(s) required. Refer to the part list for the previous disassembly procedure. The amount of screws you should be left with will be listed here also.

A box with a  will also provide any possible helpful information. A box with a  contains warnings.

An example of these types of boxes are shown in the sidebar.

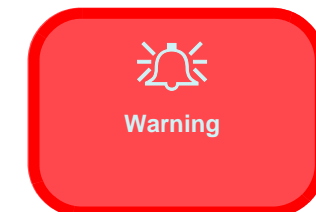

Disassembly

NOTE: All disassembly procedures assume that the system is turned **OFF**, and disconnected from any power supply (the battery is removed too).

Maintenance Tools

The following tools are recommended when working on the notebook PC:

- M3 Philips-head screwdriver
- M2.5 Philips-head screwdriver (magnetized)
- M2 Philips-head screwdriver
- Small flat-head screwdriver
- Pair of needle-nose pliers
- Anti-static wrist-strap

Connections

Connections within the computer are one of four types:

Locking collar sockets for ribbon connectors	To release these connectors, use a small flat-head screwdriver to gently pry the locking collar away from its base. When replacing the connection, make sure the connector is oriented in the same way. The pin1 side is usually not indicated.
Pressure sockets for multi-wire connectors	To release this connector type, grasp it at its head and gently rock it from side to side as you pull it out. Do not pull on the wires themselves. When replacing the connection, do not try to force it. The socket only fits one way.
Pressure sockets for ribbon connectors	To release these connectors, use a small pair of needle-nose pliers to gently lift the connector away from its socket. When replacing the connection, make sure the connector is oriented in the same way. The pin1 side is usually not indicated.
Board-to-board or multi-pin sockets	To separate the boards, gently rock them from side to side as you pull them apart. If the connection is very tight, use a small flat-head screwdriver - use just enough force to start.

Maintenance Precautions

The following precautions are a reminder. To avoid personal injury or damage to the computer while performing a removal and/or replacement job, take the following precautions:

1. **Don't drop it.** Perform your repairs and/or upgrades on a stable surface. If the computer falls, the case and other components could be damaged.
2. **Don't overheat it.** Note the proximity of any heating elements. Keep the computer out of direct sunlight.
3. **Avoid interference.** Note the proximity of any high capacity transformers, electric motors, and other strong magnetic fields. These can hinder proper performance and damage components and/or data. You should also monitor the position of magnetized tools (i.e. screwdrivers).
4. **Keep it dry.** This is an electrical appliance. If water or any other liquid gets into it, the computer could be badly damaged.
5. **Be careful with power.** Avoid accidental shocks, discharges or explosions.
 - Before removing or servicing any part from the computer, turn the computer off and detach any power supplies.
 - When you want to unplug the power cord or any cable/wire, be sure to disconnect it by the plug head. Do not pull on the wire.
6. **Peripherals** – Turn off and detach any peripherals.
7. **Beware of static discharge.** ICs, such as the CPU and main support chips, are vulnerable to static electricity. Before handling any part in the computer, discharge any static electricity inside the computer. When handling a printed circuit board, do not use gloves or other materials which allow static electricity buildup. We suggest that you use an anti-static wrist strap instead.
8. **Beware of corrosion.** As you perform your job, avoid touching any connector leads. Even the cleanest hands produce oils which can attract corrosive elements.
9. **Keep your work environment clean.** Tobacco smoke, dust or other air-borne particulate matter is often attracted to charged surfaces, reducing performance.
10. **Keep track of the components.** When removing or replacing any part, be careful not to leave small parts, such as screws, loose inside the computer.

Cleaning

Do not apply cleaner directly to the computer, use a soft clean cloth.

Do not use volatile (petroleum distillates) or abrasive cleaners on any part of the computer.



Power Safety Warning

Before you undertake any upgrade procedures, make sure that you have turned off the power, and disconnected all peripherals and cables (including telephone lines). It is advisable to also remove your battery in order to prevent accidentally turning the machine on.

Disassembly Steps

The following table lists the disassembly steps, and on which page to find the related information. **PLEASE PERFORM THE DISASSEMBLY STEPS IN THE ORDER INDICATED.**

To remove the Battery:

1. Remove the battery *page 2 - 5*

To remove the HDD:

1. Remove the battery *page 2 - 5*
2. Remove the HDD *page 2 - 6*

To remove the System Memory:

1. Remove the battery *page 2 - 5*
2. Remove the system memory *page 2 - 9*

To remove the Optical Device:

1. Remove the battery *page 2 - 5*
2. Remove the Optical device *page 2 - 11*

To remove the Processor:

1. Remove the battery *page 2 - 5*
2. Remove the processor *page 2 - 12*

To remove the Modem:

1. Remove the battery *page 2 - 5*
2. Remove the modem *page 2 - 14*

To remove the Wireless LAN Module:

1. Remove the battery *page 2 - 5*
2. Remove the HDD *page 2 - 6*
3. Remove the Wireless LAN module *page 2 - 15*

To remove the Keyboard:

1. Remove the battery *page 2 - 5*
2. Remove the keyboard *page 2 - 16*

To remove the Keyboard Shielding Plate:

1. Remove the battery *page 2 - 5*
2. Remove the keyboard *page 2 - 16*
3. Remove the shielding plate *page 2 - 17*

To remove the PCI Express VGA Card:

1. Remove the battery *page 2 - 5*
2. Remove the PCI Express VGA card *page 2 - 18*

Removing the Battery

1. Turn the computer **off**, and turn it over.
2. Locate the battery bay **1** (*Figure 2 - 1a*).
3. Slide the battery latch **2** in the direction of the arrow (towards the unlock symbol ) and hold it in place (as shown in *Figure 2 - 1b*).
4. The Battery **3** will pop up to allow you to lift it out of the bay (*Figure 2 - 1b*).

a.

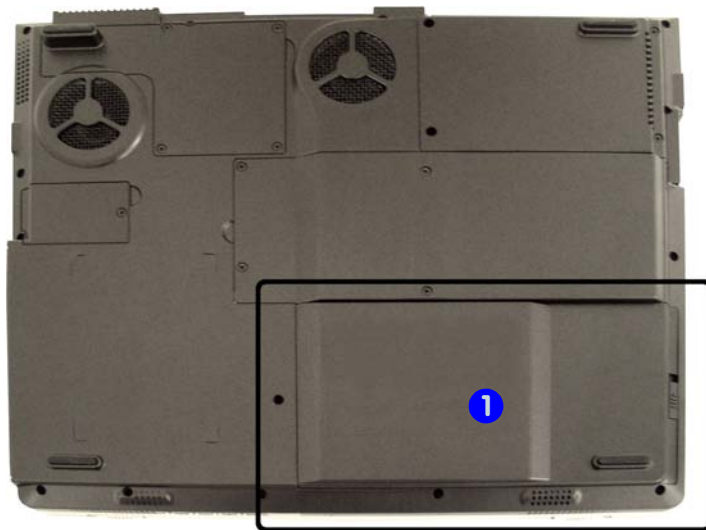

b.

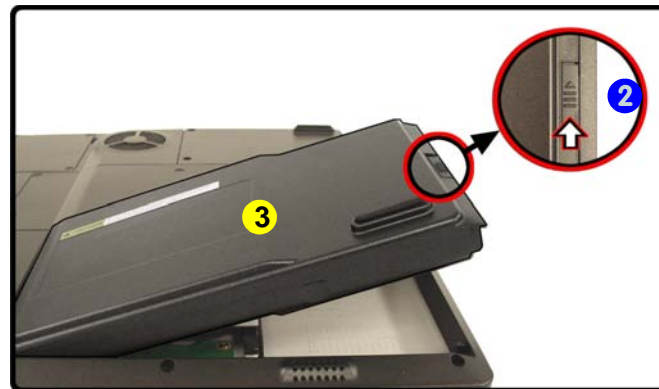
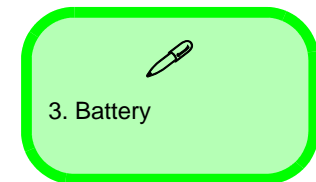

Figure 2 - 1
Battery Removal

- a. Locate the battery release latch.
- b. Release the latch and remove the battery out of the computer.



Removing the Hard Disk Drive

The hard disk drive can be taken out to accommodate other 2.5" serial (SATA) or parallel (PATA) hard disk drives (see *“Changing Serial and Parallel Hard Disk Cables” on page 2 - 8*) with a height of 9.5mm (h). Follow your operating system’s installation instructions, and install all necessary drivers and utilities (as outlined in **Chapter 4 of the User’s Manual**), when setting up a new hard disk.

1. Turn **off** the computer, turn it over and remove the battery ([page 2 - 5](#)).
2. Locate the hard disk/memory bay cover **1**.
3. Remove screws **2 - 5** and remove the bay cover **1**.

Figure 2 - 2
HDD Assembly
Removal

- a. Locate the HDD bay cover and remove the screws.
- b. Lift the cover off the computer.



HDD System Warning

New HDD's are blank. Before you begin make sure:

You have backed up any data you want to keep from your old HDD.

You have all the CD-ROMs and FDDs required to install your operating system and programs.

If you have access to the internet, download the latest application and hardware driver updates for the operating system you plan to install. Copy these to a removable medium.



1. HDD/Memory Bay Cover

- 4 Screws

a.

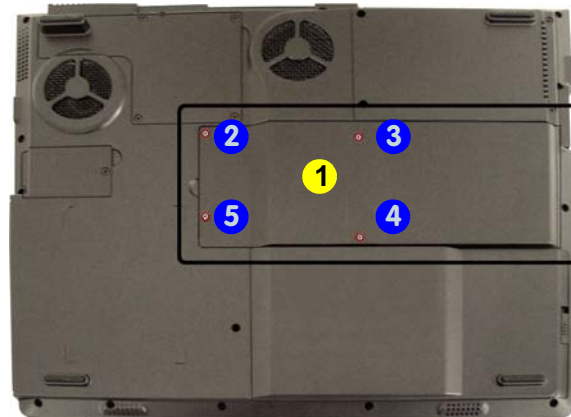

b.

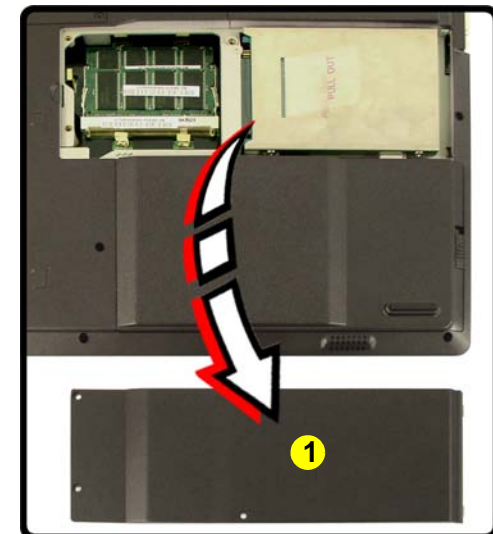

4. Pull the tab **1** in the direction of the arrow **2** in order to release the disk assembly from the connector (see [page 2 - 8](#) for instructions on changing hard disk cable types).
5. Carefully lift the hard disk assembly **3** up out off the computer.
6. Remove screws from points **4** - **7** on the side of the hard disk assembly in order to separate the bracket from the hard disk **8** (**Figure 2 - 3b**).
7. Reverse the process to install a new hard disk (pay careful attention to the orientation of the disk under the cover).

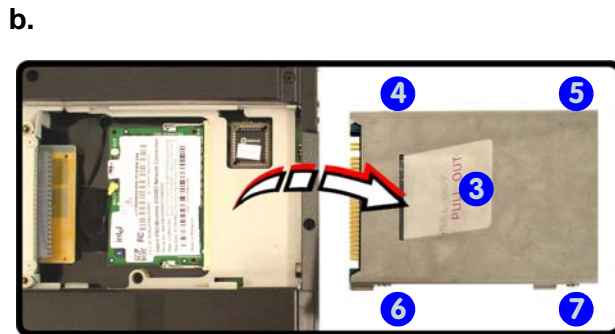
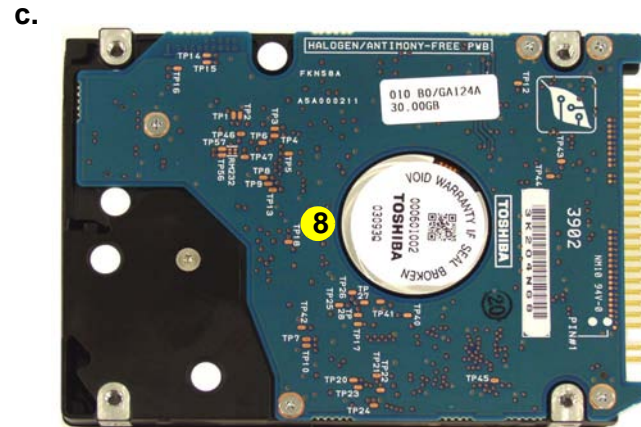
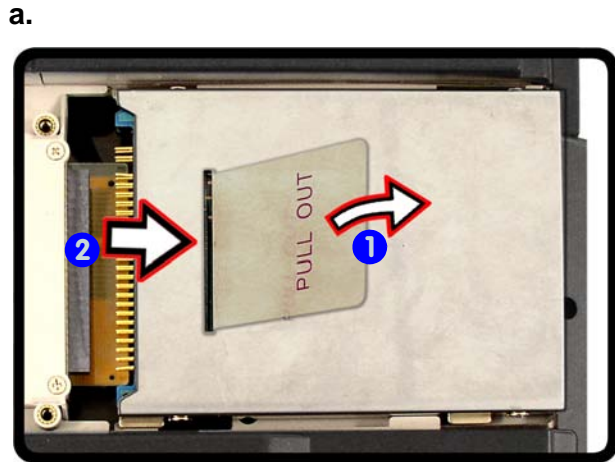

Parallel & Serial Cables
 If you wish to change your hard disk type, you will also need to change the cable (see [page 2 - 8](#) for details).

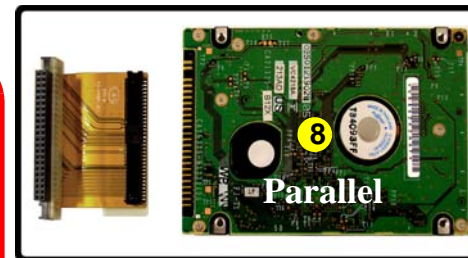



8. Hard Disk
 • 4 Screws

Figure 2 - 3
HDD Assembly Removal (Cont.)

- a. Slide out the HDD assembly.
- b. Lift the HDD assembly out of the bay and remove the screws.
- c. Separate the bracket and HDD.

Changing Serial and Parallel Hard Disk Cables

The system can support either serial (SATA) OR parallel (PATA) hard disks, however different cables are used to support each hard disk type. If you are changing hard disk types then you will be required to change the cable.

1. Remove the hard disk assembly (see page 2 - 6).
2. Remove screws ① & ②.
3. Carefully remove the cable ③.
4. Remove any cable protector ④ from the new cable.
5. Insert the new cable (be careful of the connector orientation) and re-insert screws ① & ②.
6. Insert the new hard disk (ensure it is attached to the bracket) and make sure it is firmly connected.

Figure 2 - 4
Changing Serial & Parallel HDD Cables

- a. Remove the screws.
- b. Remove the cable.
- c. Remove any cable protector from the new cable, and insert the cable.

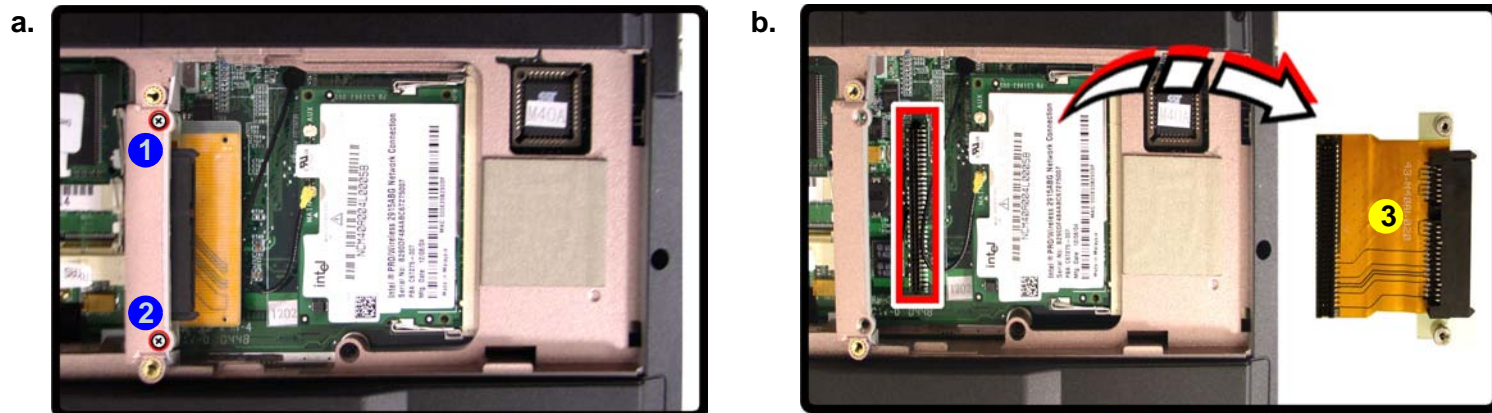

HDD Cable

You will need to bend the cable back and ensure that the connector is facing the correct direction in order to connect to the hard disk.

Be careful when pushing the cable down into the mainboard connector. Make certain that the cable and connector are correctly aligned in order to avoid damaging the mainboard.



- 3. Hard Disk Cable
- 4. Cable Protector

- 2 Screws

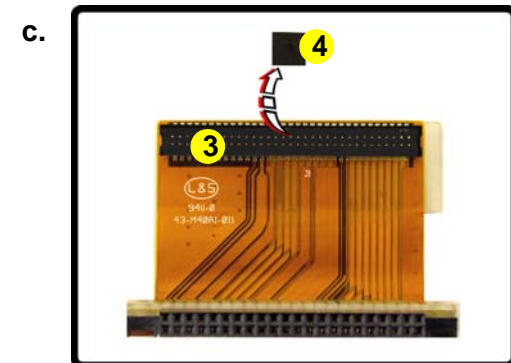

Upgrading the System Memory (RAM)

The computer has **two** memory sockets for 200 pin Small Outline Dual In-line (SO-DIMM) **DDR, OR DDRII (DDR2)** type memory modules (see *“Model Differences” on page 1 - 2* for details of supported module types).

Models M400A & M400G support **DDR RAM**; **Models M40AE & M40GE** support **DDRII (DDR2) RAM**. The total memory size is automatically detected by the POST routine once you turn on your computer.

1. Turn **off** the computer, turn it over and remove the battery (*page 2 - 5*).
2. Locate the hard disk and memory bay cover **1**.
3. Remove screws **2** - **5** and remove the bay cover **1**.

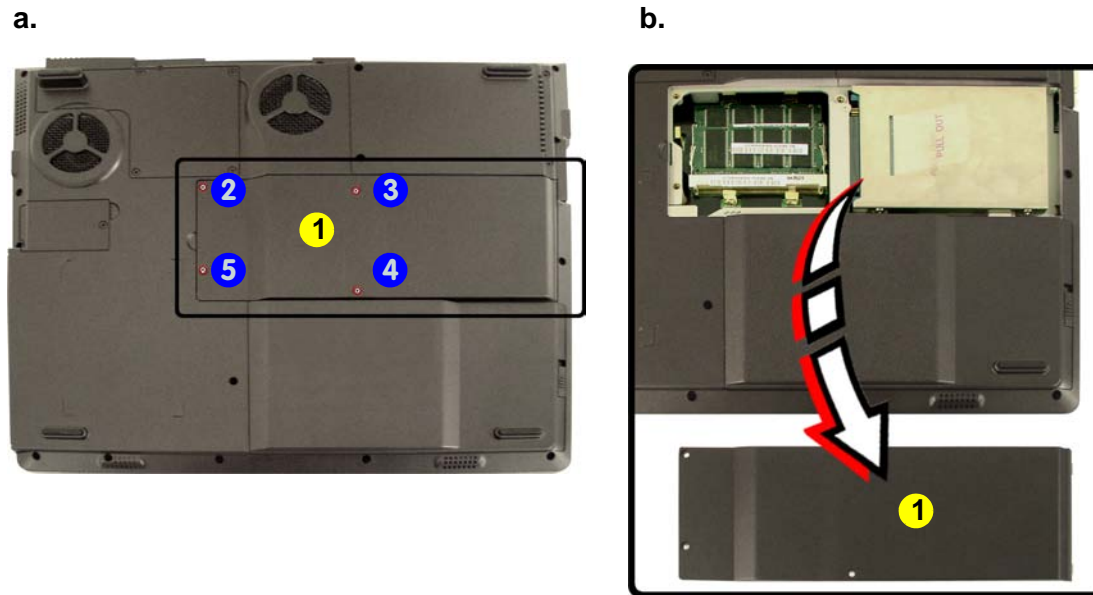
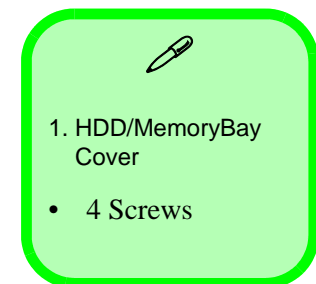

Figure 2 - 5
**Memory Socket
Cover Removal**

- a. Remove the screws.
- b. Lift the cover off the computer.



Disassembly

Figure 2 - 6
Removing/
Installing a RAM
Module

- Pull the release latch(es).
- Remove the module(s).



Contact Warning

Be careful not to touch the metal pins on the module's connecting edge. Even the cleanest hands have oils which can attract particles, and degrade the module's performance.



3. RAM Module

- Gently pull the two release latches (1 & 2) on the sides of the memory socket in the direction indicated by the arrows (Figure 2 - 6a).
- The RAM module(s) 3 will pop-up (Figure 2 - 6b), and you can then remove it.

a.

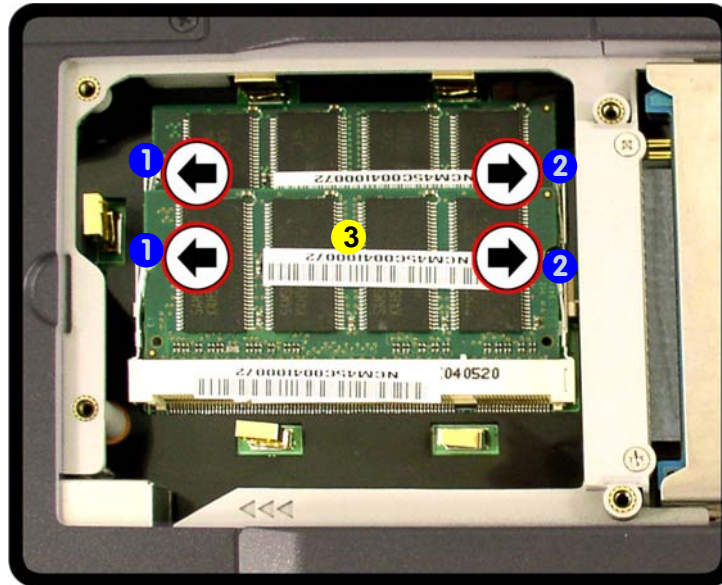

b.

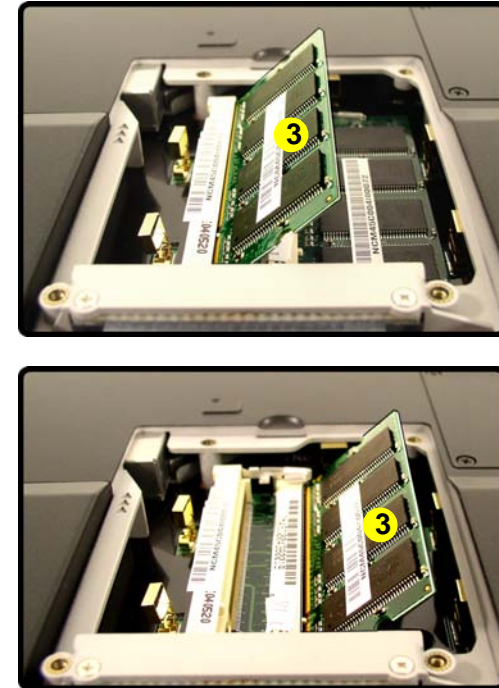

- Pull the latches to release the second module if necessary.
- Insert a new module holding it at about a 30° angle and fit the connectors firmly into the memory slot.
- The module will only fit one way as defined by its pin alignment. Make sure the module is seated as far into the slot as it will go. DO NOT FORCE IT; it should fit without much pressure.
- Press the module down towards the mainboard until the slot levers click into place to secure the module.
- Replace the memory socket cover and the 4 screws (see page 2 - 9).
- Restart the computer to allow the BIOS to register the new memory configuration as it starts up.

Removing the Optical (CD/DVD) Device

1. Turn **off** the computer, turn it over and remove the battery ([page 2 - 5](#)).
2. Locate the hard disk/memory bay cover and remove screws **1** - **5** ([Figure 2 - 7a](#)).
3. Remove the bay cover **6** ([Figure 2 - 7b](#)).
4. Use a screwdriver to apply pressure at point **7** to push the optical device **8** out of the computer ([Figure 2 - 7c](#)).
5. Insert the new device and carefully slide it into the computer (the device only fits one way. DO NOT FORCE IT; The screw holes should line up).
6. Restart the computer to allow it to automatically detect the new device.

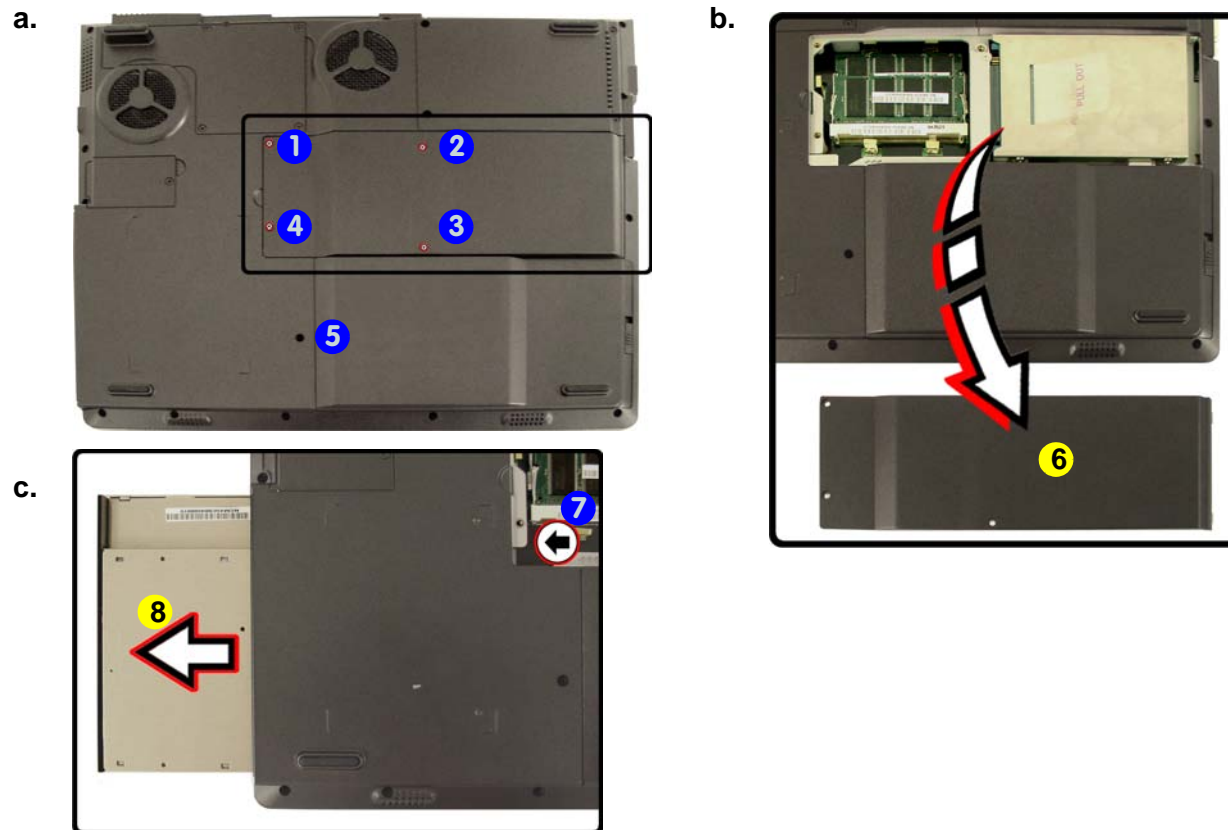
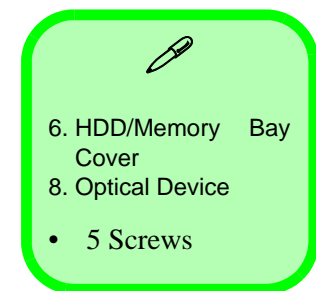

Figure 2 - 7
Optical Device Removal

- a. Remove the screws.
- b. Carefully lift the cover off the computer.
- c. Push the optical device out off the computer at point 7.



Removing the Processor

1. Turn **off** the computer, turn it over and remove the battery ([page 2 - 5](#)).
2. Remove screws **1** - **4** from the CPU cover.
3. Carefully lift up the CPU cover **5** off the computer.
4. Remove screws **6** - **8** ([Figure 2 - 8c](#)) from the heat sink in the order indicated.
5. Carefully lift up the heat sink **9** ([Figure 2 - 8d](#)) off the computer.

Figure 2 - 8

Processor Removal

- a. Remove the screws.
- b. Carefully lift the cover off the computer.
- c. Remove the screws in the order indicated.
- d. Remove the heat sink.

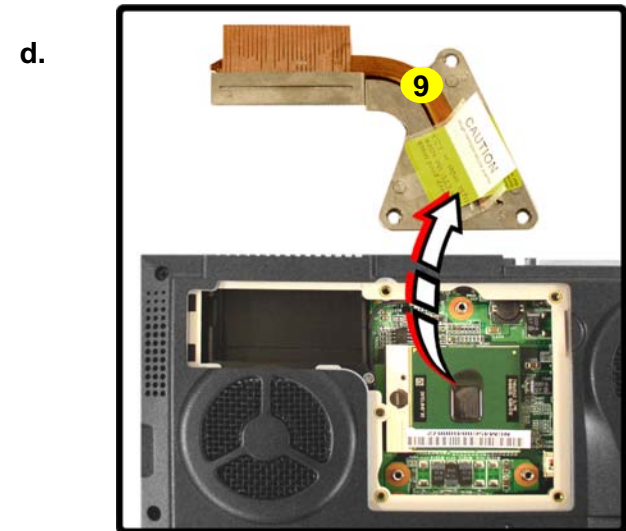
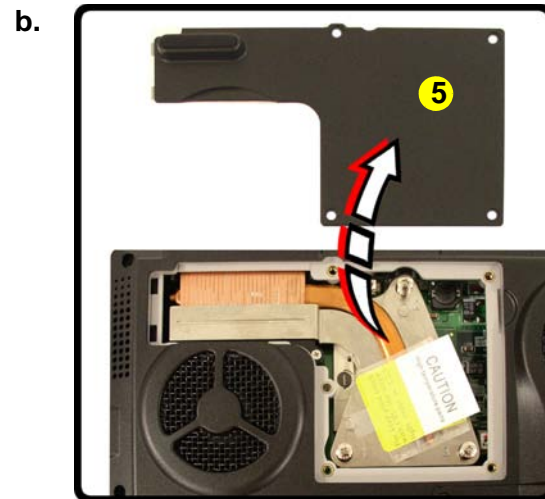
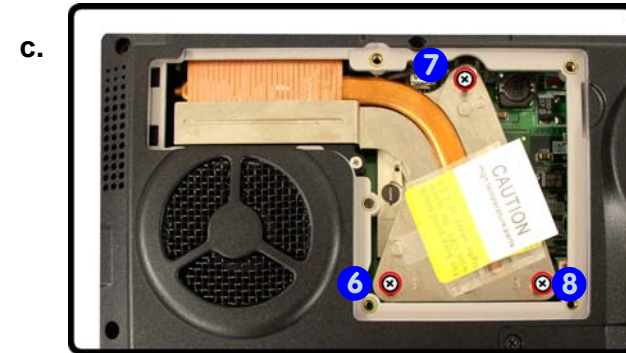
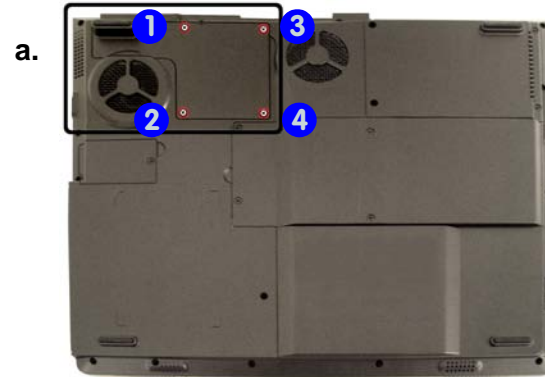

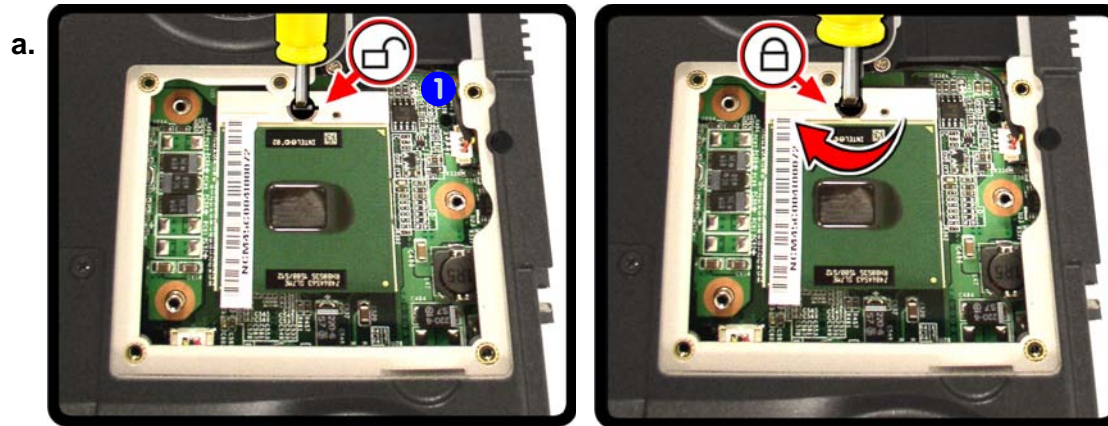

5. CPU Cover
9. Heat Sink
• 7 Screws

6. Turn the release latch **1** towards the unlock symbol , to release the CPU (*Figure 2 - 9a*).
7. Carefully (it may be hot) lift the CPU **2** up out of the socket (*Figure 2 - 9b*).
8. Reverse the process to install a new CPU.
9. When re-inserting the CPU, pay careful attention to the pin alignment, it will fit only one way (DO NOT FORCE IT!).

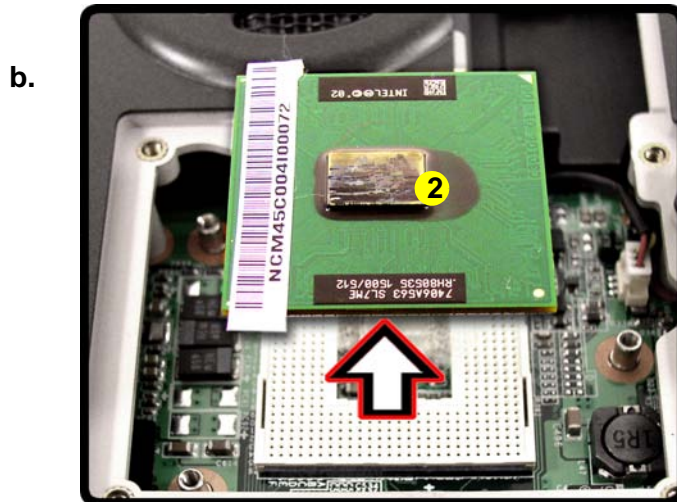

Unlock

Lock



Caution
The heat sink, and CPU area in general, contains parts which are subject to high temperatures. Allow the area time to cool before removing these parts.



2. CPU

Figure 2 - 9
Processor Removal
(cont'd)

- a. Turn the release latch to unlock the CPU.
- b. Lift the CPU out of the socket.

Removing the Modem

1. Turn **off** the computer, turn it over and remove the battery ([page 2 - 5](#)).
2. Locate the socket cover and remove screw **1** ([Figure 2 - 10a](#)).
3. Lift the cover **2** off the computer and remove screws **3** - **4** ([Figure 2 - 10b](#)).
4. Carefully separate the modem from the connector **5** and disconnect the cables **6** - **7**.
5. Lift the modem **8** ([Figure 2 - 10c](#)) up and off the computer.

Figure 2 - 10
Modem Removal

- a. Remove the screw.
- b. Lift the cover off the computer and remove the screws.
- c. Disconnect the cable and connector. Remove the module.

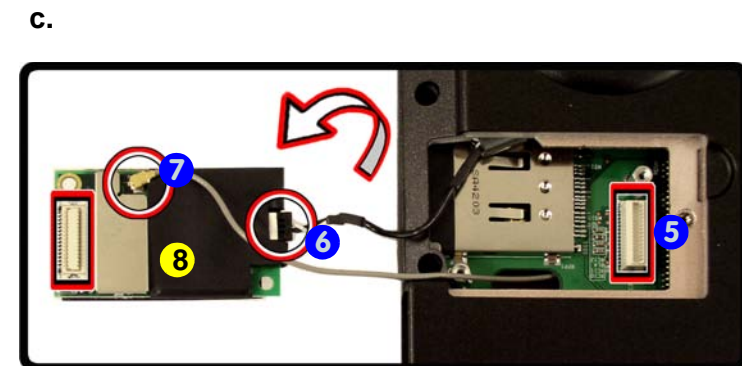
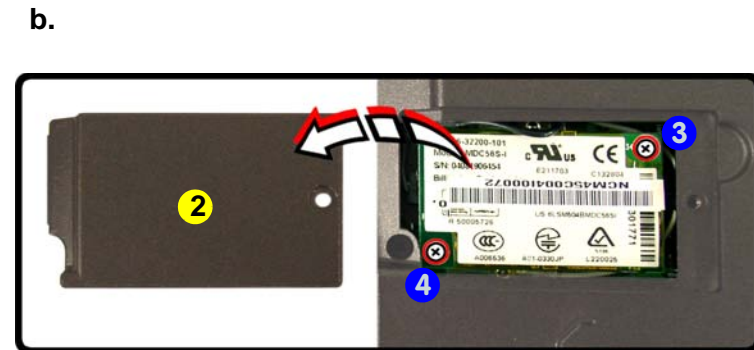

- 2. Socket Cover
- 8. Modem
- 3 Screws

Removing the Wireless LAN Module

1. Turn **off** the computer, remove the battery ([page 2 - 5](#)) and HDD ([page 2 - 6](#)).
2. Carefully disconnect cable **1**, then gently pull the two release latches (**2** - **3**) on the sides of the module socket.
3. The wireless LAN module **4** ([Figure 2 - 11b](#)) will pop-up, and you can remove it.

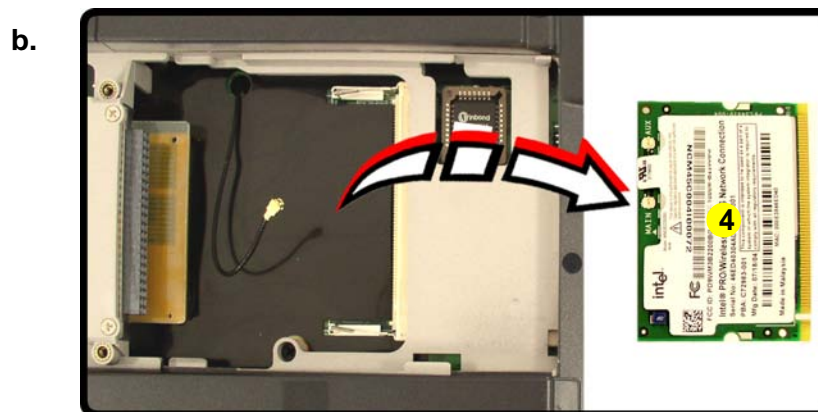
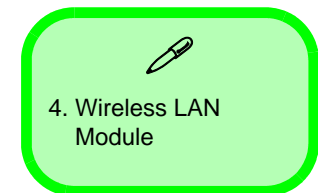

Figure 2 - 11
**Wireless LAN
Module Removal**

- a. Disconnect the cable and pull the release latches.
- b. Remove the WLAN module.

Note: Make sure you connect the antenna cable to the “Main” socket ([Figure 11a](#)).



Removing the Keyboard

1. Turn **off** the computer, and remove the battery ([page 2 - 5](#)).
2. Press the **three** keyboard latches at the top of the keyboard to elevate the keyboard from its normal position (you may need to use a small screwdriver to do this).
3. Carefully lift the keyboard **4** up, being careful not to bend the keyboard ribbon cable **5** ([Figure 2 - 12c](#)).
4. Disconnect the keyboard ribbon cable **5** from the locking collar socket **6**.

Figure 2 - 12
Keyboard Removal

- a. Press the three latches to release the keyboard.
- b. Disconnect the cable from the locking collar.
- c. Remove the keyboard.

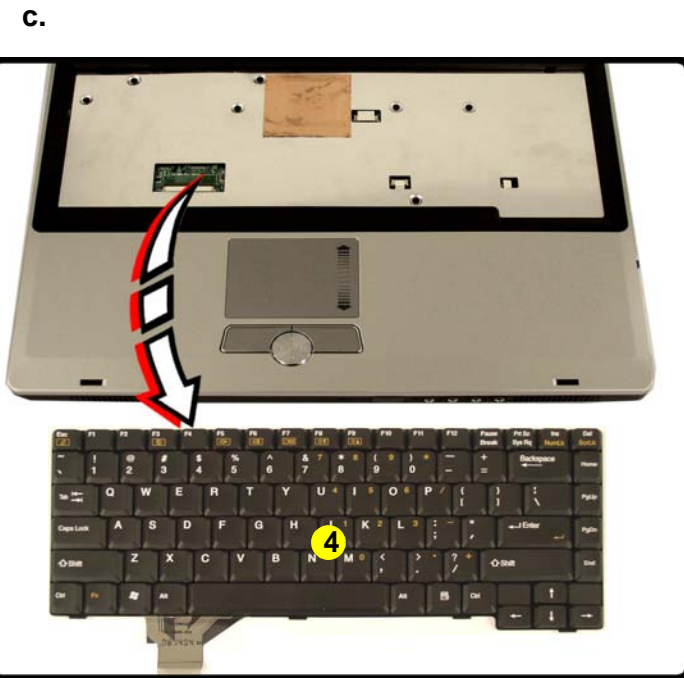
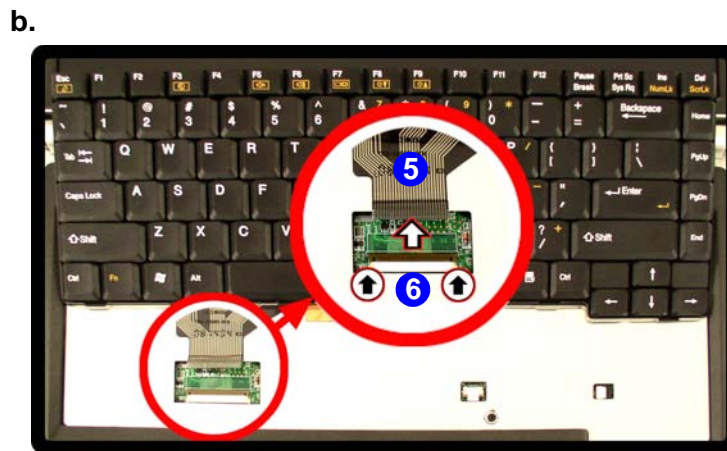

Re-Inserting the Keyboard

When re-inserting the keyboard firstly align the **five** keyboard tabs at the bottom of the keyboard with the slots in the case.



4. Keyboard

Removing the Keyboard Shielding Plate

1. Turn **off** the computer, remove the battery ([page 2 - 5](#)) and keyboard ([page 2 - 16](#)).
2. Remove screws **1** - **7** from the keyboard shielding plate **8** ([Figure 2 - 13a](#)).
3. Carefully lift the keyboard shielding plate **8** off the computer ([Figure 2 - 13b](#)).
4. Disconnect the cable **9** and connectors **10** & **11** from the mainboard ([Figure 2 - 13c](#)).

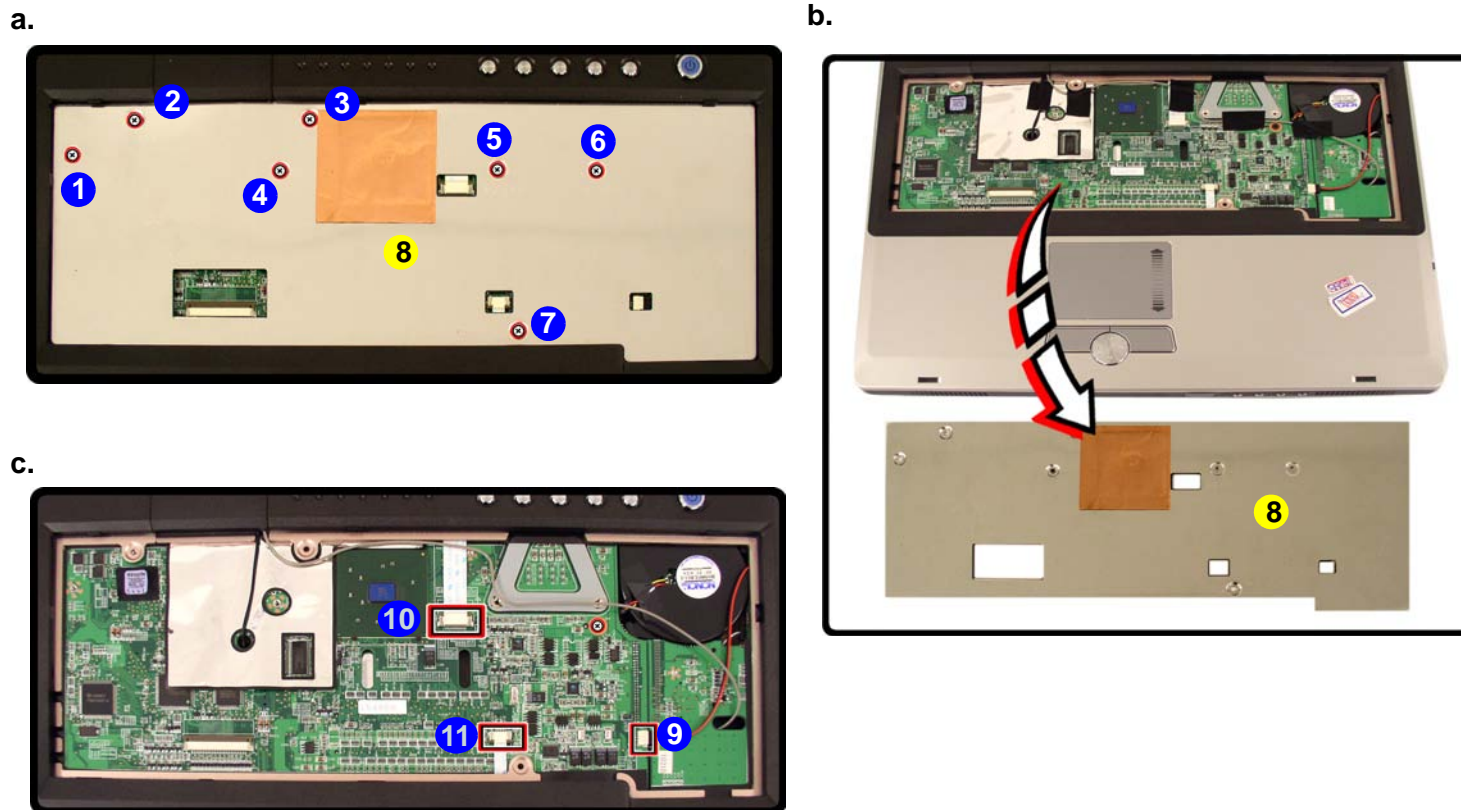



Figure 2 - 13
Keyboard Shielding Plate Removal

- Remove the screws.
- Remove the shielding plate.
- Disconnect the cable and connectors.



8. Shielding Plate

- 7 Screws

Disassembly

Removing the PCI Express VGA Card

1. Turn **off** the computer, turn it over and remove the battery ([page 2 - 5](#)).
2. Remove screws **1** - **4** from the VGA card cover.
3. Carefully lift up the VGA card cover **5** off the computer.
4. Remove screws **6** - **9** ([Figure 2 - 14c](#)) from the PCI Express VGA card.
5. Slide the PCI Express VGA card in the direction indicated by the arrow **10** ([Figure 2 - 14d](#)), and lift the card off the computer.

Figure 2 - 14
PCI Express VGA
Card Removal

- Remove the screws.
- Lift the cover off the computer.
- Remove the screws.
- Slide the VGA card in the direction of the arrow.
- Remove the PCI Express VGA Card.

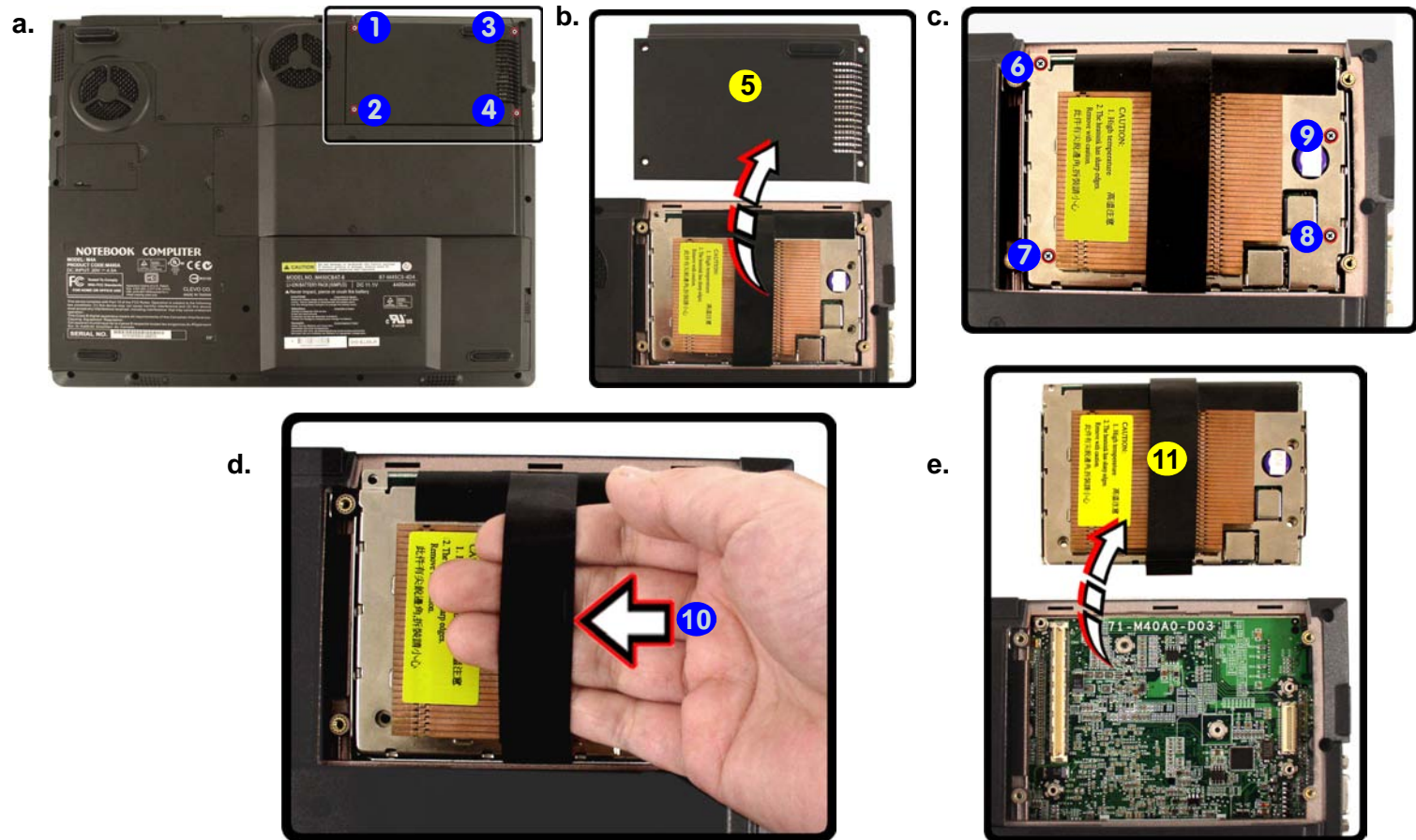

- 5. CPU Cover
- 9. PCI Express VGA Card
- 8 Screws

Appendix A: Part Lists

This appendix breaks down the *M400A/M400G/M40AE/M40GE* series notebook's construction into a series of illustrations. The component part numbers are indicated in the tables opposite the drawings.

Note: This section indicates the *manufacturer's* part numbers. Your organization may use a different system, so be sure to cross-check any relevant documentation.

Note: Some assemblies may have parts in common (especially screws). However, the part lists DO NOT indicate the total number of duplicated parts used.

Note: Be sure to check any update notices. The parts shown in these illustrations are appropriate for the system at the time of publication. Over the product life, some parts may be improved or re-configured, resulting in *new* part numbers.

Part List Illustration Location

The following table indicates where to find the appropriate part list illustration.

Table A - 1
**Part List Illustration
 Location**

Part	M400A	M40AE	M400G	M40GE
Top	<i>page A - 3</i>			
Bottom	<i>page A - 4</i>	<i>page A - 5</i>	<i>page A - 6</i>	<i>page A - 7</i>
LCD	<i>page A - 8</i>			
CD-ROM Drive - SAMSUNG	<i>page A - 9</i>			
Combo Drive - QSI	<i>page A - 10</i>			
Combo Drive - TEAC	<i>page A - 11</i>			
DVD-DUALRW Drive - LITEON	<i>page A - 12</i>			
DVD-DUALRW Drive - PIONEER	<i>page A - 13</i>			
DVD Drive - QSI	<i>page A - 14</i>			
Hard Disk Drive	<i>page A - 15</i>			

Top (M400A/M40AE/M400G/M40GE)

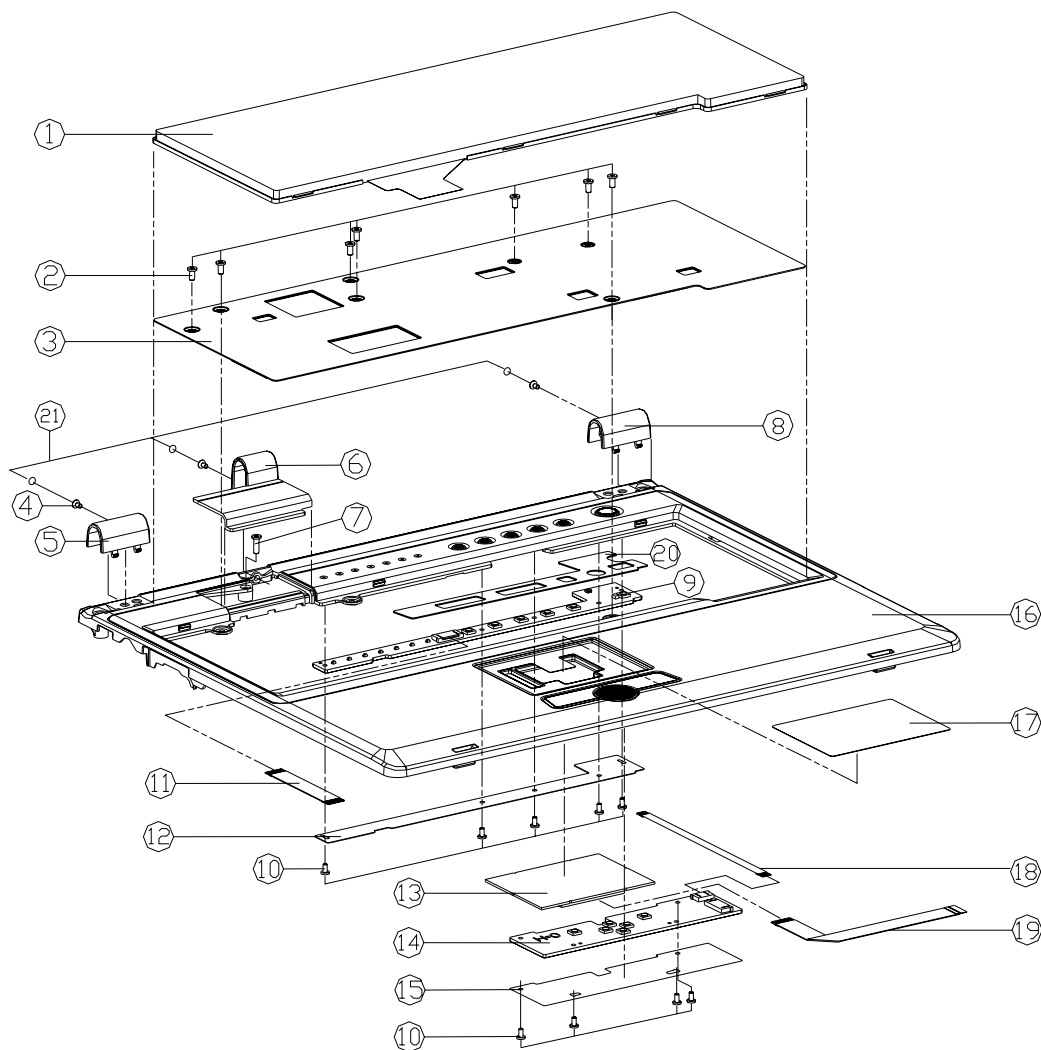

Figure A - 1
Top
(M400A/M40AE/
M400G/M40GE)

ITEM	PART NAME	PART NO	REMARK
1	KEYBOARD	80-M40A0-011-1	
2	SCREW M2.5*5L KI BK/Z ICT NY	35-B6125-5RA	
3	KEYBOARD SHIELDING 無鉛	33-M40A7-013	
4	SCREW M2*4L F NI ICT NY	35-21120-4RA	
5	HINGE COVER (L)(右標記) 無鉛	42-M40AY-022	
6	CONNECTOR COVER (右標記) 無鉛	42-M40A3-101	
7	SCREW M2.5*8L KI BK/Z NY ICT 無鉛	35-B6125-8R0	
8	HINGE COVER (R)(右標記) 無鉛	42-M40AY-012	
9	LED BOARD	77-M40A4-D04	
10	SCREW M2*4L KI BNI ICT NY	35-B9120-4RA	
11	FTC CABLE FOR LED BOARD RP PITCH#5 無鉛	43-M40A4-010	
12	MYLAR FOR PWR+HOTKEY -LED BOARD	40-M40A3-020	
13	TOUCH PAD ELANTECH 332004-1105	49-M40A2-D02	
14	CLICK BOARD	77-M40A2-D03	
15	MYLAR FOR CLICK BOARD	40-M40A3-030	
16	TOP CASE MODULE 無鉛	39-M40A2-011	
17	MYLAR FOR TOUCHPAD 無鉛	40-M40A3-041	
18	FTC CABLE FOR CLICK BOARD RP PITCH#5 無鉛	43-M40A2-010	
19	FTC CABLE FOR TOUCHPAD BOARD RP PITCH#5 無鉛	43-M40A2-020	
20	PWR+HOTKEY ESD SHIELDING	47-M40AS-050	
21	MYLAR φ4.3 (右標記) M400A	40-M40A3-0B0	

A.Part Lists

Bottom (M400A)

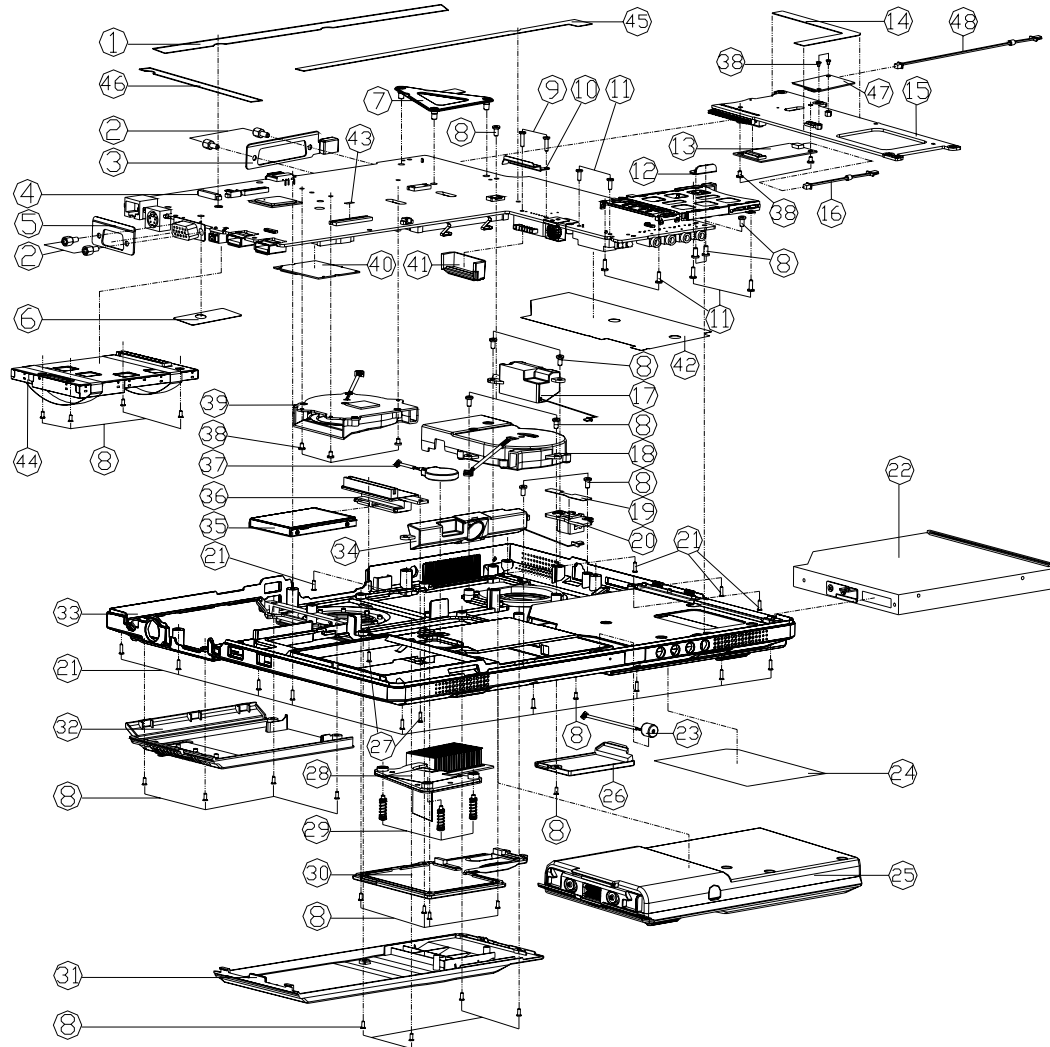
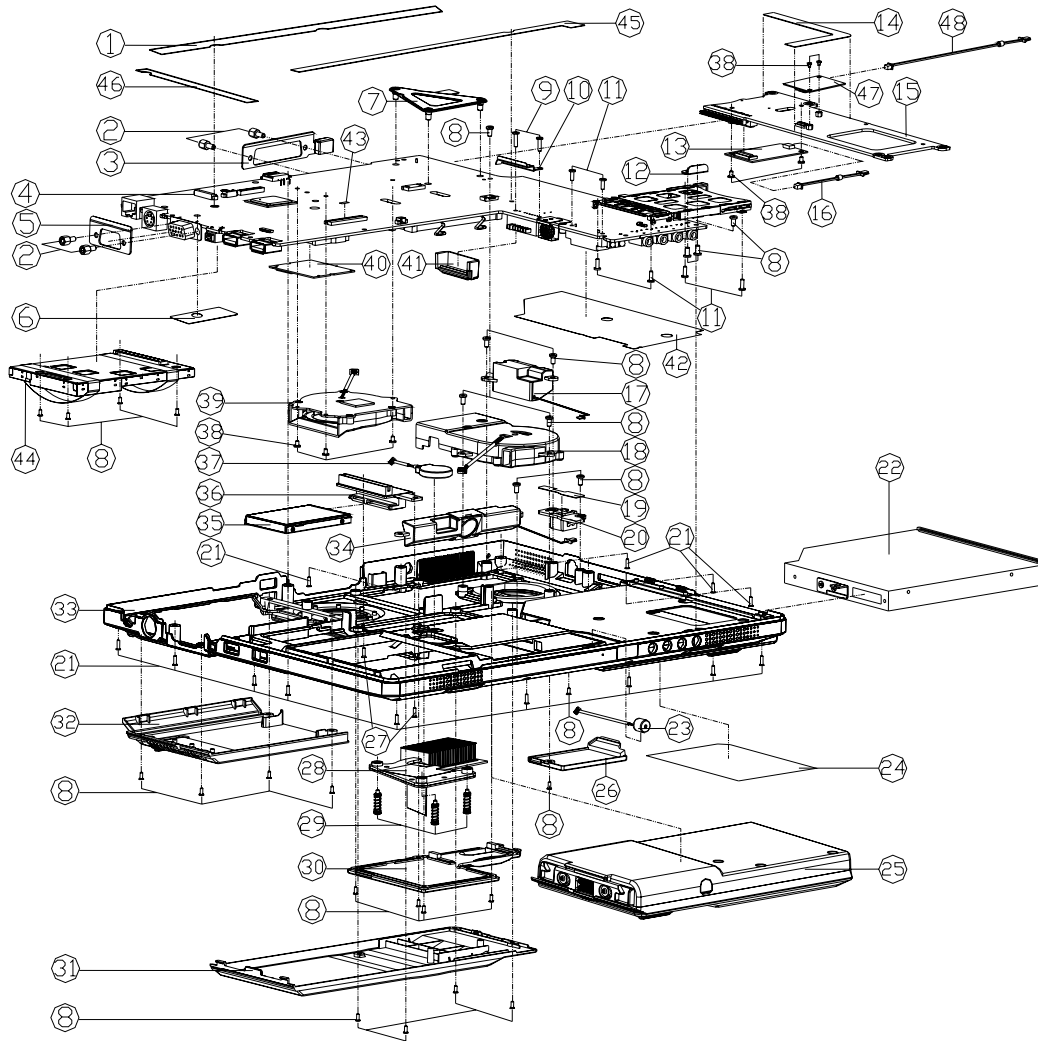

Figure A - 2
Bottom
(M400A)

ITEM	PART NAME	PART NO	REMARK
1	MYLAR SIZE FOR W/BCDST DOWN/UP TOP SIDE	40-M40A3-0J0	
2	HEX STUD(X)M22 NI-PL) 11mm	34-07009-011	
3	BRACKET FOR PARALLEL PORT(M/B)	33-M40A2-090	
4	MAIN BOARD	77-M40A0-003	
5	BRACKET FOR CRT PORT (M/B/M400A)	33-M40A2-020	
6	MYLAR FOR M/B TOP SIDE	40-M40A3-0K0	
7	CPU SUPPORTER MODULE	33-M40AS-101	
8	SCREW M2.5*5L K1 BK/Z ICT NY	35-B6125-5RA	
9	SCREW M2*11L P NI ICT NY	35-01120-11A	
10	BRACKET FOR BATTERY CONNECTOR(B USE)	33-M40AM-010	
11	SCREW M2*7L K1 NI ICT NY	35-B1120-7RA	
12	REINFORCE BRACKET FOR M/B	33-M40A2-070	
13	MYLAR FOR EPIN SHIELDING REV.6 (CASE BALL) (FOR D901)	88-D70T1-392	
14	MYLAR FOR CARD READER BOARD	40-M40A3-080	
15	CARD READER BOARD	77-M40AV-D03	
16	MC CABLE 2P AVG.30 L=43MM(BLUE)TOOTH COMD(M400A)	43-M40AU-021	
17	SPK -R 16*16*1.5W 110MM	23-51615-110	
18	FAN MODULE FOR CPU	31-M40AS-100	
19	MYLAR FOR RJ-11 BOARD	40-M40A3-070	
20	RJ11 BOARD	77-M40AH-D02	
21	SCREW M2.5*8L K1 BK/Z NY ICT	35-B6125-8R0	
22	CD-ROM ASS'Y	79-M40AZ-000	Reference Assy No (99-M40AS-070)
22	DVD/RW ASS'Y (option)	79-M40AQ-000	Reference Assy No (99-M40AS-060)
22	DVD ASS'Y(option)	79-M40AV-000	Reference Assy No (99-M40AS-050)
22	COMBO ASS'Y(option)	79-M40AX-000	Reference Assy No (99-M40AS-040)
23	MC CABLE 2P AVG.30 L=22MM(W/CABLE)	43-E0602-700	
24	PRODUCT LABEL M400A	45-M40A3-010	
25	MINI-SLL 66MM*16MM*3MM(SAMSUNG) CELLS	87-M40AS-4D6	
25	MINI-SLL 66MM*16MM*3MM (MILLI-CELL) CELLS	87-M40AS-496	
26	BLUETOOTH COVER	42-M40AB-011	
27	SCREW M2.5*8.5*P*BL NI K1 ICT NY	35-B1125-8R0	
28	CPU HEATSINK MODULE	31-M40AN-100	
29	SCREW M2.5*4.5*P*9.5.0F=35L=9.5.5*25 B	31-41025-095	
30	CPU COVER MODULE	42-M40AS-101	
31	HDD COVER	42-M40A1-011	
32	VGA COVER MODULE	42-M40A3-201	
33	BOTTOM CASE MODULE	39-M40A3-021	
34	SPK-L 16*16*6.5 1.5W 125MM	23-51615-125	
35	W/D HDD ASS'Y M400A	79-M40A1-010	
36	HDD FPC CABLE TO IDE 44P	43-M40A1-011	FOR IDE
36	HDD FPC CABLE TO SATA 28P	43-M40A1-020	FOR SATA
37	BAT. 2000 3V 230MAH W/CABLE 50MM CR2032	23-22015-P80	
38	SCREW M2*4 K1 NI ICT GY-PATCH (M400A)	35-B1120-3RD	
39	FAN MODULE FOR SYSTEM	31-M40AS-200	
40	LAN BRD(L=86MM) MINI-PCI 28 INTEL 250MHZ LAN CARD	88-M40A2-420	
40	INTEL CALEXO 2 220MHZ MINI-PCI 28 BRD(L=86MM) WIRELESS LAN CARD	88-M37E2-420	
40	MINI-PCI WIRELESS LAN CARD INTEL CALEXO BRD(L=86MM)	88-M35E0-420	
41	SAFETY RUBBER FOR BATT. CONN.(M/B)BLACK	47-M40AM-010	
42	MYLAR FOR M/B(CDST DOWN)	40-M40A3-0E0	
43	MYLAR(S=40*25H) FOR 8SV LCD(SAMSUNG)	40-00150-150	
44	VGA BOARD (ATI-M24)	77-D70TL-D02-1	
44	VGA BOARD (ATI-M26)	77-D70TL-D02-A	
44	VGA BOARD (ATI-M28-P)	77-D70TL-D02-B	
45	MYLAR FOR M/B(CDST DOWN)	40-M40A3-0F0	
46	MYLAR 990(SUPPORTER W/BCDST DOWN/UP LEFT SIDE)	40-M40A3-0H0	
47	MYLAR FOR EPIN SHIELDING REV.6 (CASE BALL) (FOR D901)	88-D90T1-392	
47	MYLAR FOR EPIN SHIELDING REV.6 (CASE BALL) (FOR D901)	88-D90T1-534	
48	MC CABLE 2P AVG.30 L=43MM(BLUE)TOOTH COMD	43-M40AU-010	

Bottom (M400AE)



ITEM	PART NAME	PART NO	REMARK
1	MYLAR SHEET MYLAR FOR W/BCOST DOWN/UP TOP SIDE	40-M40A3-0J0	
2	HEX STUICKSUM22 NI-PLJ 11mm	34-07009-011	
3	BRACKET FOR PARALLEL PORT(M/B)	33-M40A2-09D	
4	MAIN BOARD	77-M40A0-D06A	
5	BRACKET FOR CRT PORT (M/B/M400A)	33-M40A2-020	
6	MYLAR FOR M/B TOP SIDE	40-M40A3-0K0	
7	CPU SUPPORTER MODULE	33-M40AS-101	
8	SCREW M2.5*5L K1 BK/Z ICT NY	35-B6125-5RA	
9	SCREW M2*11L P NI ICT NY	35-01120-11A	
10	BRACKET FOR BATTERY CONNECTOR(B USED)	33-M40AM-010	
11	SCREW M2*7L K1 NI ICT NY	35-B1120-7RA	
12	REINFORCE BRACKET FOR M/B	33-M40A2-070	
13	NEED KALIA 12 PIN MOC 15 CASTLE(TOP) FOR DPT	88-D70T1-394	
14	MYLAR FOR CARD READER BOARD	40-M40A3-080	
15	CARD READER BOARD	77-M40AV-D03	
16	MOB CABLE 2P AVG30 L65MM*P*BLUE TOOTH COMBO(M400A)	43-M40AU-021	
17	SPK -R 16*16*15W 110MM	23-51615-110	
18	FAN MODULE FOR CPU	31-M40AS-100	
19	MYLAR FOR RJ-11 BOARD	40-M40A3-070	
20	RJ11 BOARD	77-M40AH-D02	
21	SCREW M2.5*6L K1 BK/Z NY ICT	35-B6125-BR0	
22	CD-ROM ASS'Y	79-M40AZ-000	Reference Assy No. C99-M40AS-0703
22	DVD/RW ASS'Y (option)	79-M40A0-000	Reference Assy No. C99-M40AS-050
22	DVD ASS'Y(option)	79-M40AV-000	Reference Assy No. C99-M40AS-050
22	COMBO ASS'Y(option)	79-M40AX-000	Reference Assy No. C99-M40AS-050
23	MOB GMSX(M400A) 2V-10V 22K W/CABLE	23-E0602-700	
24	PRODUCT LABEL M40AE	45-M40AE-010	
25	BATT*3511 650MHV M400A(SAMSUNG)R CELLS	87-M40AS-4D6	
25	BATT*3511 650MHV M400A(SH) CELLS	87-M40AS-496	
26	BLUE TOOTH COVER	42-M40AB-011	
27	SCREW M2.5*0.45P*6L NI K1 ICT NY	35-B1125-8R0	
28	CPU HEATSINK MODULE	31-M40AN-100	
29	SCREW M2.5*0.45P*5.0L-35L-95.5*25 B	35-41025-095	
30	CPU COVER MODULE	42-M40AS-101	
31	HDD COVER	42-M40A1-011	
32	VGA COVER MODULE	42-M40A3-201	
33	BOTTOM CASE MODULE	39-M40A3-021	
34	SPK-L 16*16*6.5 1.5W 125MM	23-51615-125	
35	W/O HDD ASS'Y M400A	79-M40A1-010	
36	HDD FPC CABLE TO IDE 44P	43-M40A1-011	FOR IDE
36	HDD FPC CABLE TO SATA 22P	43-M40A1-020	FOR SATA
37	BATT 2000 3V 230MAH W/CABLE 56MM CR2032	23-22015-P80	
38	SCREW M2X1 NI NI ICT QTY-PATCH (88-M40T-080)	35-B1120-3RD	
39	FAN MODULE FOR SYSTEM	31-M40AS-200	
40	MYLAR SHEET MYLAR FOR INTEL PROSING MYLAR (88)	88-M40A2-420	
40	INTEL CALDEX 2 2200G MM FOR 38 BRET(4) W/LESS LAM CAR	88-M37E2-420	
40	MYLAR FOR WIRELESS LAN CARD INTEL CALDEX(88)	88-M3520-420	
41	SAFETY RUBBER FOR BATT. CONN.(M/B)BLACK	47-M40AM-010	
42	MYLAR FOR M/BCOST DOWN	40-M40A3-0E0	
43	MYLAR(S*4*0.25) FOR 85V LCD(SAMSUNG)	40-00150-150	
44	VGA BOARD (ATI-M24)	77-D70TL-D02-1	
44	VGA BOARD (ATI-M26)	77-D70TL-D02-A	
44	VGA BOARD (ATI-M22-P)	77-D70TL-D02-B	
45	MYLAR FOR M/BCOST DOWN	40-M40A3-0F0	
46	MYLAR PROSING(MOC) DOWN/UP LEFT SIDE	40-M40A3-0H0	
47	NEED KALIA 12 PIN MOC 15 CASTLE(TOP) FOR DPT	88-D90T1-392	
47	NEED KALIA 12 PIN MOC 15 CASTLE(TOP) FOR DPT	88-D90T1-534	
48	MOB CABLE 2P AVG30 L65MM*P*BLUE TOOTH COMBO	43-M40AU-010	

Figure A - 3
Bottom
(M400AE)

A.Part Lists

Part Lists

Bottom (M400G)

Figure A - 4
Bottom
(M400G)

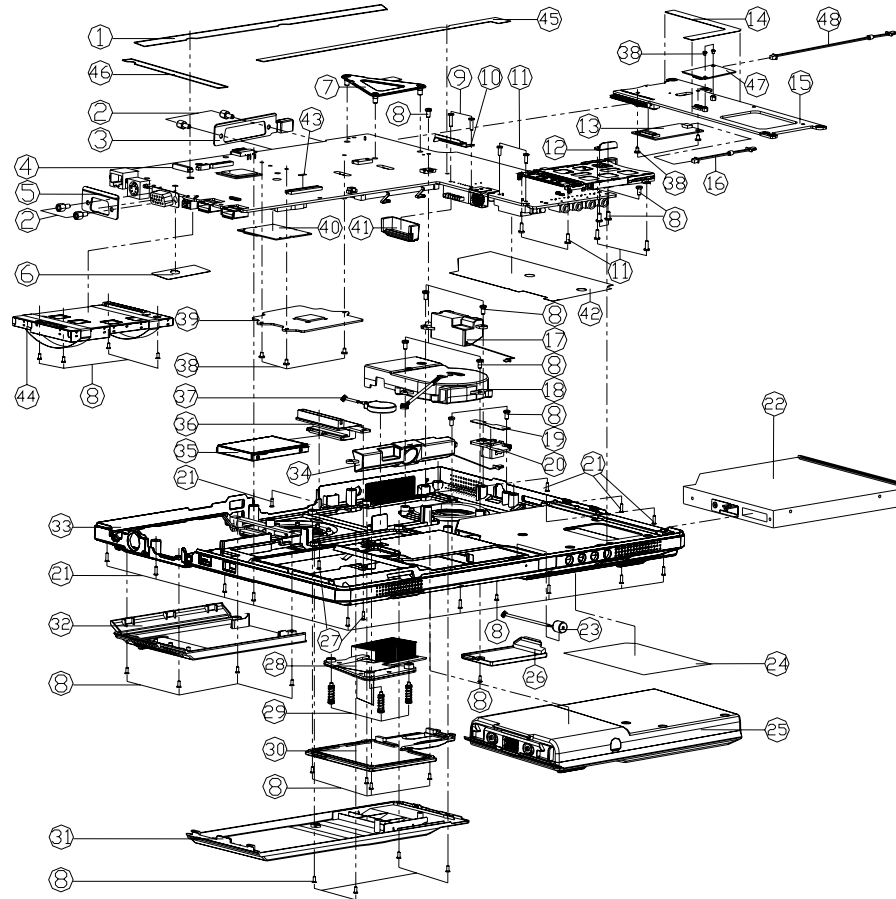

ITEM	PART NAME	PART NO	REMARK
1	MYLAR USED FOR WAREHOUSE STORAGE TOP SIDE (無色)	40-M40A3-0J0	
2	HEX STUD(SUM2E NI-PL) 11mm	34-07009-011	
3	BRACKET FOR PARALLEL PORT(M/B)	33-M40A2-090	
4	MAIN BOARD	77-M40G0-D06	
5	BRACKET FOR CRT PORT (M/B/M400A)	33-M40A2-020	
6	MYLAR FOR M/B TOP SIDE (白色/無色/有膜)	40-M40A3-0K0	
7	CPU SUPPORTER MODULE (無色)	33-M40AS-101	
8	SCREW M2.5xSL KI BK/Z ICT NY	35-B6125-SRA	
9	SCREW M2x11L P NI ICT NY (有膜)	35-01120-11A	
10	BRACKET FOR BATTERY CONNECTOR(B USED) (有膜/無膜)	33-M40AM-010	
11	SCREW M2x7L KI NI ICT NY	35-B1120-7RA	
12	REINFORCE BRACKET FOR M/B (無色)	33-M40A2-070	
13	MYLAR USED IN PARALLEL CTR VIO THROUGH LAMINUM	88-D70T1-394	
14	MYLAR FOR CARD READER BOARD (無色/有膜)	40-M40A3-080	
15	CARD READER BOARD	77-M40AV-D03	
16	MC CABLE 2P ANG 20P BLUE/TOOTH COMBO/M40A	43-M40AU-021	
17	SPK -R 16x16x15W 110MM	23-51615-110	
18	FAN MODULE FOR CPU	31-M40AS-110	
19	MYLAR FOR RJ-11 BOARD (無色/有膜)	40-M40A3-070	
20	RJ11 BOARD	77-M40AH-D03	
21	SCREW M2.5xSL KI BK/Z NY ICT NY	35-B6125-BR0	
22	CD-ROM ASS'Y	79-M40Z-000	Reference Assy. No. (99-M40AS-070)
22	DVD/RW ASS'Y (option)	79-M40A0-000	Reference Assy. No. (99-M40AS-060)
22	DVD ASS'Y(option)	79-M40AV-000	Reference Assy. No. (99-M40AS-060)
22	CD/BD ASS'Y(option)	79-M40AX-000	Reference Assy. No. (99-M40AS-060)
23	MC CABLE(SATA/FL) 2Y-10V 22K Y/CABLE	23-E0602-700	
24	PRODUCT LABEL M400G	45-M40G3-010	
25	BATTERY CELL 6600mAh 3.7V 245mAh (CELL)	87-M40AS-4D6	
26	BLUE/TOOTH COVER (無色) (無色)	87-M40AS-496	
27	SCREW M2.5x4.5PxSL NI KI ICT NY	35-B1125-BR0	
28	CPU HEATSINK MODULE (無色)	31-M40AN-100	
29	SCREW M2.5x4.5PxSL 35L-193.5x25 B	35-41025-095	
30	CPU COVER MODULE (無色) (無色)	42-M40AS-101	
31	HDD COVER (銀黑色) (無色)	42-M40A1-011	
32	VGA COVER MODULE (銀黑色) (無色)	42-M40A3-201	
33	BOTTOM CASE MODULE (無色) (無色)	39-M40A3-021	
34	SPK-L 16x16x6.5 15W 125MM	23-51615-125	
35	W/D HDD ASS'Y M400A	79-M40A1-010	
36	HDD FPC CABLE TO IDE 44P (無色) (無色)	43-M40A1-011-I	FOR IDE
36	HDD FPC CABLE TO SATA 20P (無色) (無色)	43-M40A1-020-I	FOR SATA
37	BAT. 2000 2V 220mAh Y/CABLE 56MM CR2032	23-22015-P80	
38	SCREW NICKEL KI M KT GR-FINISH (M-NI) (無色)	35-B1120-3RD	
39	AL PLATE FOR SYSTEM (無色)	33-M40GS-010	
40	MYLAR USED IN WAREHOUSE STORAGE (無色) (無色)	88-M40A2-421	
40	MYLAR USED IN WAREHOUSE STORAGE (無色) (無色)	88-M37E2-420	
40	MYLAR USED IN WAREHOUSE STORAGE (無色) (無色)	88-M3520-420	
40	MYLAR USED IN WAREHOUSE STORAGE (無色) (無色)	88-M40A2-422	
40	MYLAR USED IN WAREHOUSE STORAGE (無色) (無色)	88-M40A2-423	
40	MYLAR USED IN WAREHOUSE STORAGE (無色) (無色)	88-M40A2-424	
41	SAFETY RUBBER FOR BATT. CONTACT/SPRINGS (無色)	47-M40AM-010	
42	MYLAR FOR M/B/CDSST DOWN	40-M40A3-0E0	
43	MYLAR(S+H250) FOR 85V LOCK/SMSUNG	40-00150-150	
44	VGA DAUGHTER BOARD(M-24)	77-D70TL-D02-1	
44	VGA DAUGHTER BOARD(M-26)	77-D70TL-D02-A	
44	VGA DAUGHTER BOARD(M-22)	77-D70TL-D02-B	
44	VGA DAUGHTER BOARD(M-22-32M)	77-D70TL-D02-C	
44	VGA DAUGHTER BOARD(M24-128M)	77-D70TL-D02-D	
44	VGA DAUGHTER BOARD(M26-256M)	77-D70TL-D02-E	
45	MYLAR FOR M/B/CDSST DOWN	40-M40A3-0F0	
46	MYLAR USED IN WAREHOUSE STORAGE LEFT SIDE (無色)	40-M40A3-0H0	
47	MYLAR USED IN WAREHOUSE STORAGE (無色) (無色)	88-D90T1-392	
47	MYLAR USED IN WAREHOUSE STORAGE (無色) (無色)	88-D70T1-394	
48	MC CABLE 2P ANG 20 L 45MM/BLUE/TOOTH COMBO	43-M40AU-010	FOR MDC 12PIN
48	MC CABLE 2P ANG 20P BLUE/TOOTH COMBO/M40A	43-M40AU-021	FOR MDC 30PIN

A.Part Lists

Bottom (M400GE)

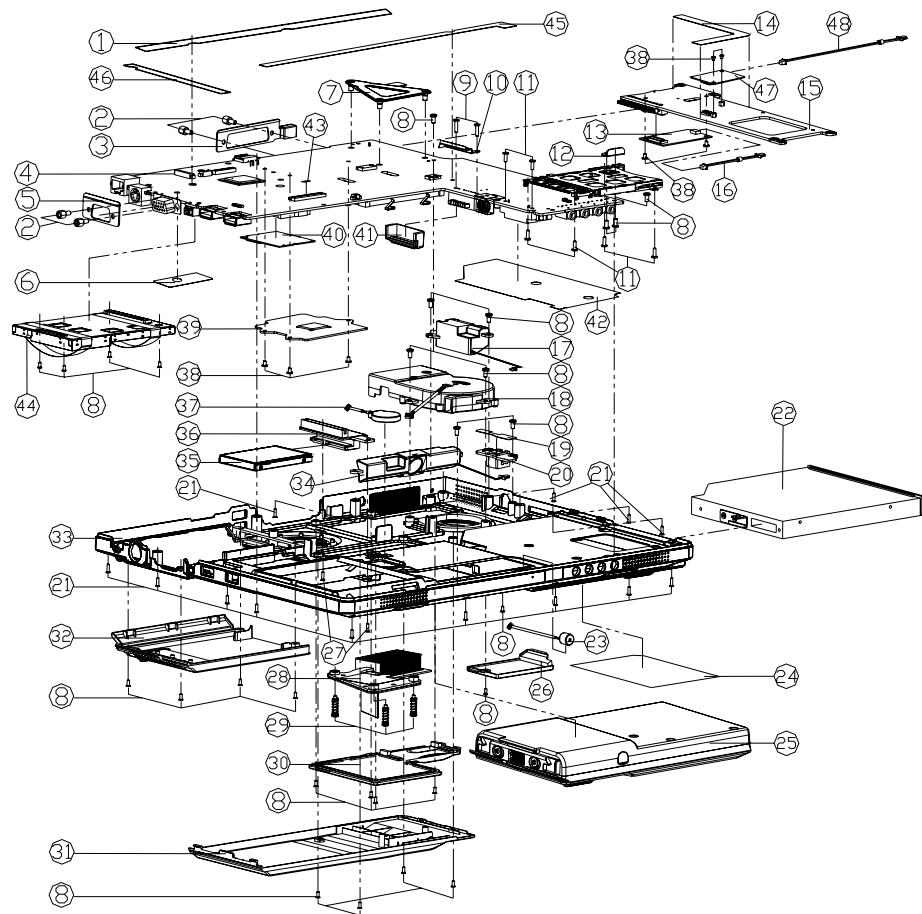

ITEM	PART NAME	PART NO	REMARK
1	MAIN BOARD FOR M400GE BOTTOM TOP SIDE (無鉛)	40-M40A3-0J0	
2	HEX STUDCSUM22 NI-PL3 11mm	34-07009-011	
3	BRACKET FOR PARALLEL PORT(M/B)	33-M40A2-090	
4	MAIN BOARD	77-M40G0-D06A	
5	BRACKET FOR CRT PORT (M/B/M400A)	33-M40A2-020	
6	MYLAR FOR M/B TOP SIDE (E/F/無鉛)	40-M40A3-0K0	
7	CPU SUPPORTER MODULE (無鉛)	33-M40A5-101	
8	SCREW M2.5x5L K1 BK/Z ICT NY (有鉛)	35-B6125-5RA	
9	SCREW M2x11L P NI ICT NY (有鉛)	35-01120-11A	
10	BRACKET FOR BATTERY CONNECTION/USED (有鉛)	33-M40AM-010	
11	SCREW M2x7L K1 NI ICT NY	35-B1120-7RA	
12	REINFORCE BRACKET FOR M/B (無鉛)	33-M40A2-070	
13	MOCK AURA MIC 3 PIN/BLUETOOTH CSR (E2) PROXESOR LAM (無鉛)	88-D70T1-394	
14	MYLAR FOR CARD READER BOARD (無鉛)	40-M40A3-0B0	
15	CARD READER BOARD	77-M40AV-D03	
16	MIC CABLE 2P AVG.30 1/4" BLUE/TOOTH COVER/MANA (無鉛)	43-M40AU-021	
17	SPK -R 16x16x1.5W 110HM	23-51615-110	
18	FAN MODULE FOR CPU	31-M40A5-110	
19	MYLAR FOR RJ-11 BOARD (無鉛)	40-M40A3-070	
20	RJ11 BOARD	77-M40AH-D03	
21	SCREW M2.5x8L K1 BK/Z NY ICT (無鉛)	35-B6125-8R0	
22	CD-ROM ASS'Y	79-M40A2-000	Reference Ass'y. Info C99-M40A5-0700
22	DVD/RW ASS'Y (option)	79-M40A0-000	Reference Ass'y. Info C99-M40A5-0600
22	DVD ASS'Y(option)	79-M40AV-000	Reference Ass'y. Info C99-M40A5-0500
22	COMBO ASS'Y(option)	79-M40AX-000	Reference Ass'y. Info C99-M40A5-0400
23	MIC GANESUNG(SUN-FD) 2V-10V 22K W/CABLE	23-E0602-700	
24	PRODUCT LABEL M400GE	45-M40GE-010	
25	BATTERY CELL SAMWON/SAKURA/2 CELLS	87-M40A5-4D6	
25	BATTERY CELL SAMWON/SAKURA/1 CELL - CELL CELLS	87-M40A5-496	
26	BLUETOOTH COVER (無鉛)	42-M40A3-013	
27	SCREW M2.5x0.45x8L NI K1 ICT NY	35-B1125-8R0	
28	CPU HEATSINK MODULE (無鉛)	31-M40AN-100	
29	SCREW M2.5x0.45x5.0x35L-953-25 B	35-41025-095	
30	CPU COVER MODULE (無鉛)	42-M40A5-101	
31	HDD COVER (銀黑色) (無鉛)	42-M40A1-011	
32	VGA COVER MODULE (銀黑色) (無鉛)	42-M40A3-201	
33	BOTTOM CASE MODULE (銀黑色) (無鉛)	39-M40A3-021	
34	SPK-L 16x16x6.5 1.5W 125MM	23-51615-125	
35	W/D HDD ASS'Y M400A	79-M40A1-010	
36	HDD FPC CABLE TO IDE 44P (IDE M400A)	43-M40A1-011-1	FOR IDE
36	HDD FPC CABLE TO SATA 22P (IDE M400A)	43-M40A1-020-1	FOR SATA
37	BAT. 2000 3V 220mAh W/CABLE 50MM CR2032	23-22015-P80	
38	SCREW M2x8 K1 NI ICT 6H-PHOS (08-1441)-080 (無鉛)	35-B1120-3RD	
39	AL PLATE FOR SYSTEM (無鉛)	33-M40G5-010	
40	WLAN BROADCASTING WIRELESS LAN PCI 20 INTEL 2296AG WLAN CARD (U) (無鉛)	88-M40A2-421	
40	WLAN CALDEXE 2296AG WIRELESS LAN PCI 20 INTEL 2296AG WIRELESS LAN CARD	88-M37E2-420	
40	WLAN-PCI WIRELESS LAN CARD INTEL CALDEXE (無鉛)	88-M3520-420	
40	WLAN BROADCASTING WIRELESS LAN PCI 20 INTEL 2296AG WLAN CARD (J) (無鉛)	88-M40A2-422	
40	WLAN BROADCASTING WIRELESS LAN PCI 20 INTEL 2296AG WLAN CARD (U) (無鉛)	88-M40A2-423	
40	WLAN BROADCASTING WIRELESS LAN PCI 20 INTEL 2296AG WLAN CARD (M) (無鉛)	88-M40A2-424	
41	SAFETY RUBBER FOR BATT. CONN.(M/B) (無鉛)	47-M40AM-010	
42	MYLAR FOR M/B/COST DOWN	40-M40A3-0E0	
43	MYLAR(S48x254) FOR 85V LCD(SAMSUNG)	40-00150-150	
44	VGA DAUGHTER BOARD(M-24)	77-D70TL-D02-1	
44	VGA DAUGHTER BOARD(M-26)	77-D70TL-D02-A	
44	VGA DAUGHTER BOARD(M-22)	77-D70TL-D02-B	
44	VGA DAUGHTER BOARD(M-22-32M)	77-D70TL-D02-C	
44	VGA DAUGHTER BOARD(M-24-128M)	77-D70TL-D02-D	
44	VGA DAUGHTER BOARD(M-26-256M)	77-D70TL-D02-E	
45	MYLAR FOR M/B/COST DOWN	40-M40A3-0F0	
46	MYLAR PROXESOR/M400GE BOTTOM/LEFT SIDE (無鉛)	40-M40A3-0H0	
47	MOCK AURA LSPK 3PIN/BLUETOOTH CSR (E2) PROXESOR LAM (無鉛)	88-D90T1-392	
47	MOCK AURA MIC 3 PIN/BLUETOOTH CSR (E2) PROXESOR LAM (無鉛)	88-D70T1-394	
48	MIC CABLE 2P AVG.30 1/4" BLUE/TOOTH COVER	43-M40AU-010	FOR MDC 12PIN
48	MIC CABLE 2P AVG.30 1/4" BLUE/TOOTH COVER/MANA	43-M40AU-021	FOR MDC 30PIN

Figure A - 5
Bottom
(M400GE)

A.Part Lists

LCD (M400A/M40AE/M400G/M40GE)

Figure A - 6
LCD
(M400A/M40AE/
M400G/M40GE)

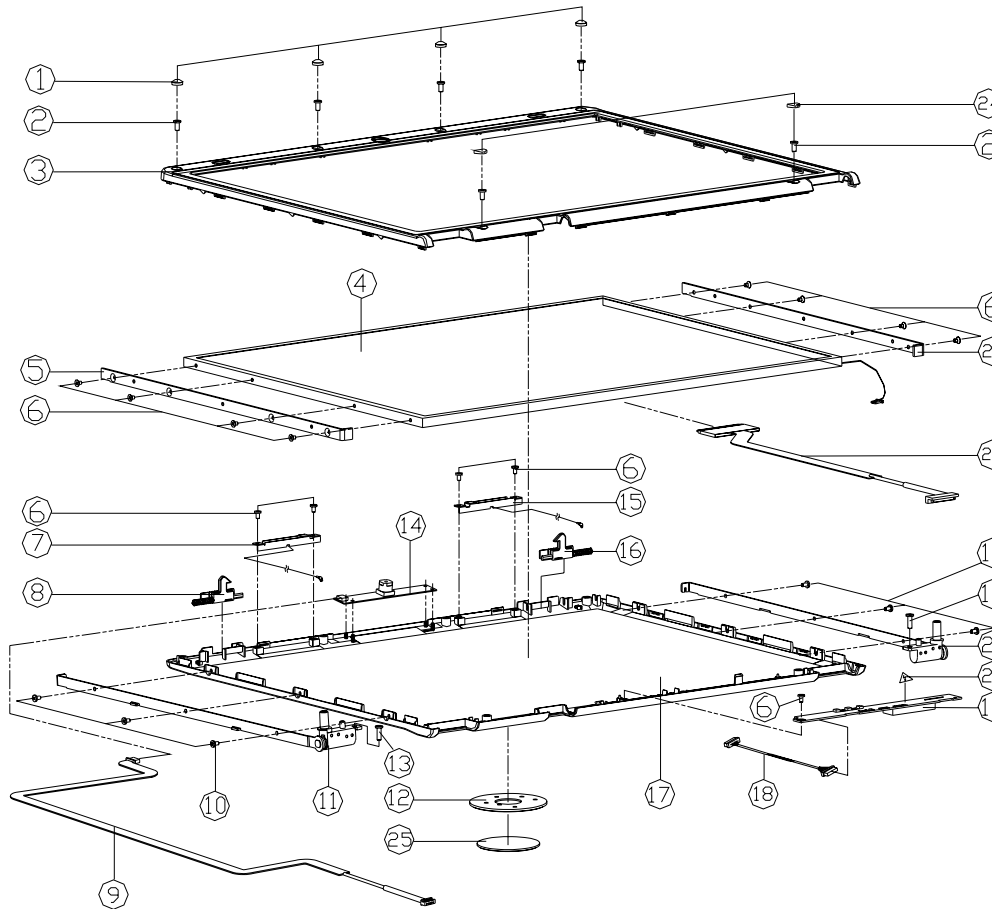

ITEM	PART NAME	PART NO	REMARK
1	RUBBER FOR LCD (TOP)	47-56P32-011	
2	SCREW M2.5*5L K1 NI ICT NY	35-B1125-SRA	
3	FRONT COVER MODULE M400A	39-M40A1-011	
4	LCD T OPT CLASSIPRHS-GRAB) 15" XGA 7.0MM	50-L5270-C03	
4	LCD T AU B150XG01 15" XGA 6.0mm	50-L2260-C00	
4	LCD T OPT CLASSIPRHS-GRAB) 15" XGA	50-L2260-C00	
4	LCD T AU RESIPGH VHS-GRAB) 15" XGA 5.9MM	50-L5259-G01	
4	LCD T SAMSUNG LTN150U3-L03 15" XGA 6.0MM	50-L2260-M00	
4	LCD T LG LP150U03-A2P1 15" UXGA	50-L4207-L01	
5	LCD BRACKET L CLASSIPRHS M400A, SECC 151	33-M40A1-020	
6	SCREW M2*3.5L K1 NI ICT NY	35-B1120-350	
7	ANTENNA PFA BLUE100M 2.4GHZ L-85MM GRAY M400A	23-742R4-D30	
8	HOOK KNOB L MODULE M400A	42-M40A1-800	
9	CCD CABLE CM3036 300K PIXELS, RESOLUTION	43-M40AT-010	OPTION
10	SCREW M2.0*3L F NI ICT NY	35-21120-3RA	
11	LCD HINGE MODULE L 151 M400A	33-M40A1-600	
12	LOGO BASE M400A AL2.0T	33-M40A1-090	
13	SCREW M2.5*5L K1 BK/Z NY ICT	35-B6125-8R0	
14	VIDEO CAMERA 300K TASSI3001B 949-T	88-M12CC-410	OPTION
15	ANTENNA PFA VLAJ BUL BAND L-60MM BLACK M400A	23-742R4-D20	
16	HOOK KNOB R MODULE M400A	42-M40A1-700	
17	BACK COVER MODULE M400A	39-M40A1-021	
18	INVERTER CABLE 12P AWG.32	43-M40AR-010	
19	EPS INVERTER BOARD	76-DB00R-011	
20	ELECTRIC SHOCK CAUTION B2H	45-82004-000	
21	LCD HINGE MODULE R 151 M400A	33-M40A1-500	
22	LCD COAXIAL CABLE FOR AU/B150XG01V2)	43-M40A1-010	
22	LCD COAXIAL CABLE FOR OPT(LA150P00)	43-M40A1-020	
22	LCD COAXIAL CABLE FOR LG(LA150U03)	43-M40A1-040	
23	LCD BRACKET R CLASSIPRHS M400A, SECC 151	33-M40A1-010	
24	DISPLAY RUBBER PAD (DOWN)	47-D4001-020	
25	LOGO FOR NOTEBOOK	45-M40A1-011	

CD-ROM Drive - SAMSUNG (M400A/M40AE/M400G/M40GE)

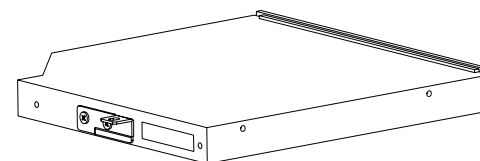
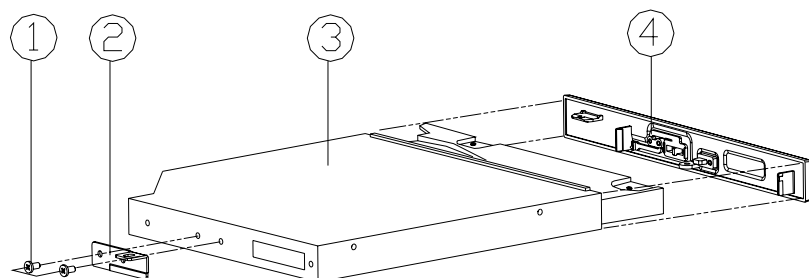

Figure A - 7
**CD-ROM Drive -
 SAMSUNG
 (M400A/M40AE/
 M400G/M40GE)**

ITEM	PART NAME	PART NO	REMARK
1	SCREW M2*3L KI NI ICT NY	35-B1120-3RB	
2	CD ROM FIX BRACKET	33-M40AZ-010	
3	CD-ROM 5 1/4" 24X SN-124 SAMSUNG	85-607□X-S00	
4	CD-ROM BEZEL MODULE SAMSUNG	42-M40AZ-200	

A.Part Lists

Combo Drive - QSI (M400A/M40AE/M400G/M40GE)

Figure A - 8
 Combo Drive - QSI
 (M400A/M40AE/
 M400G/M40GE)

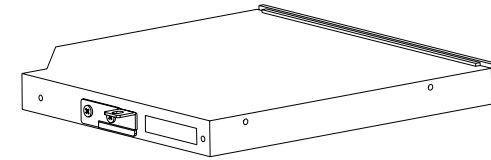
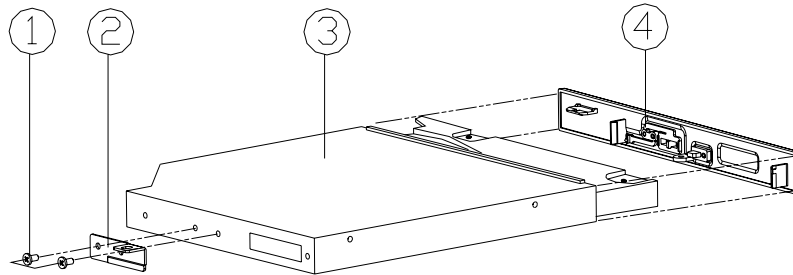

ITEM	PART NAME	PART NO	REMARK
1	SCREW M2*3L KI NI ICT NY	35-B1120-3RB	
2	CD ROM FIX BRACKET	33-M40AZ-010	
3	CD-RW/DVD 5 1/4" 24X 12.7mm SBW-242B QSI	85-907□X-C02	
4	DVD BEZEL MODULE QSI	42-M40AX-100	

Combo Drive - TEAC (M400A/M40AE/M400G/M40GE)

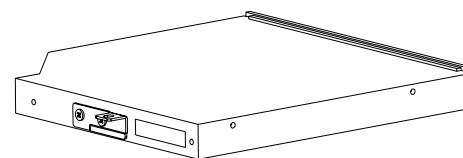
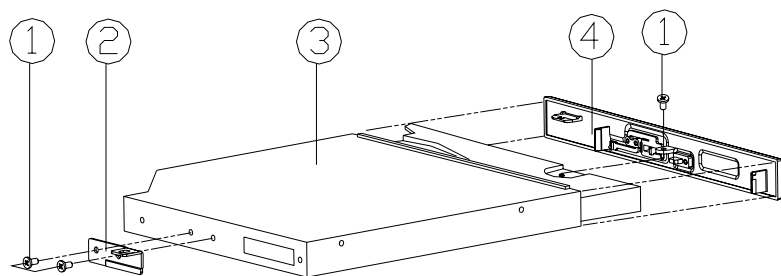

Figure A - 9
Combo Drive -
TEAC
(M400A/M40AE/
M400G/M40GE)

ITEM	PART NAME	PART NO	REMARK
1	SCREW M2*3L KI NI ICT NY	35-B1120-3RB	
2	CD ROM FIX BRACKET	33-M40AZ-010	
3	CD-RW/DVD 5 1/4" 24X 12.7mm DW-224E-A20A TEAC	85-907□X-702	
4	COMBO BEZEL MODULE TEAC 24X	42-M40AX-300	

A.Part Lists

DVD-DUALRW Drive - LITEON (M400A/M40AE/M400G/M40GE)

Figure A - 10
DVD-DUALRW Drive - LITEON
(M400A/M40AE/
M400G/M40GE)

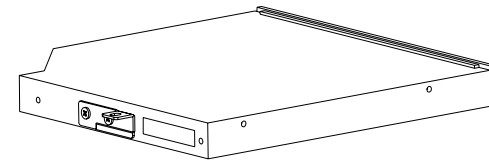
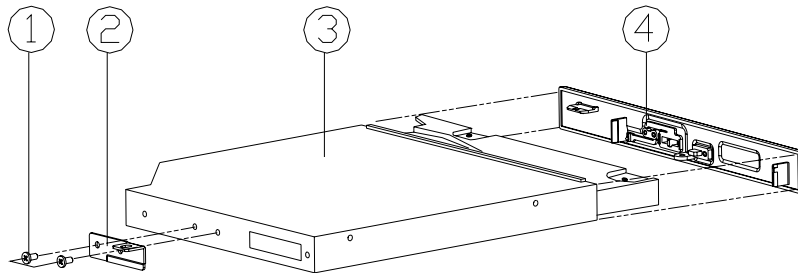

ITEM	PART NAME	PART NO	REMARK
1	SCREW M2*3L KI NI ICT NY	35-B1120-3RB	
2	CD RDM FIX BRACKET	33-M40AZ-010	
3	DVD/DUAL RW 5 1/4" 8X 12.7mm SDSW-852S LITEON	85-A078X-L00	
4	DVD/DUAL BEZEL MODULE LITEON(SDSW-852S)	42-M40AQ-300	

DVD-DUALRW Drive - PIONEER (M400A/M40AE/M400G/M40GE)

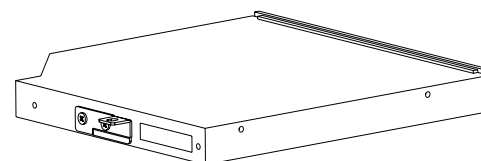
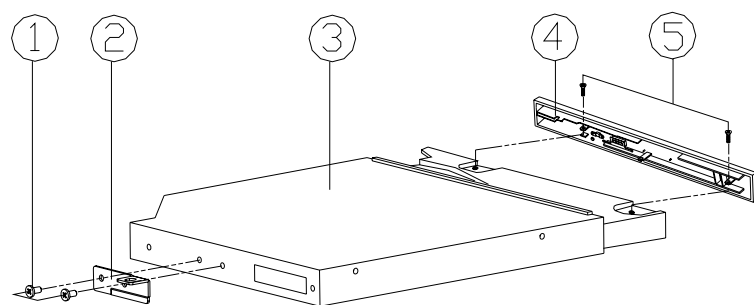

Figure A - 11
DVD-DUALRW Drive - PIONEER (M400A/M40AE/M400G/M40GE)

ITEM	PART NAME	PART NO	REMARK
1	SCREW M2*3L KI NI ICT NY	35-B1120-3RB	
2	CD ROM FIX BRACKET	33-M40AZ-010	
3	DVD/DUAL RW 5 1/4" 8X 12.7mm DVR-K14RA PIONEER	85-A078X-B00	
4	PIONEER DVD+RW(DUAL) BEZEL MODULE	42-M40AQ-200	
5	SCREW Ø1.7*5L I BZ	35-C6117-5R0	

A.Part Lists

DVD Drive - QSI (M400A/M40AE/M400G/M40GE)

Figure A - 12
DVD Drive - QSI
(M400A/M40AE/
M400G/M40GE)

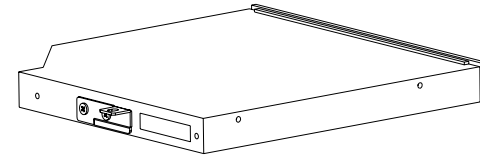
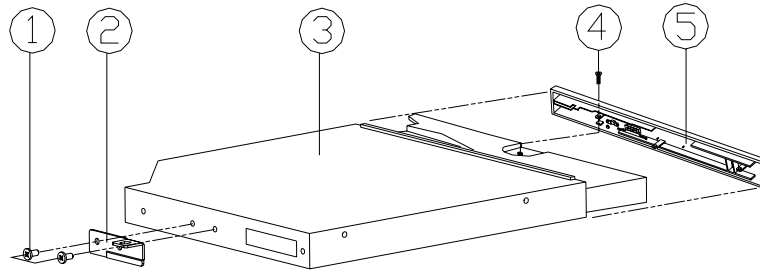

ITEM	PART NAME	PART NO	REMARK
1	SCREW M2*3L KI NI ICT NY	35-B1120-3RB	
2	CD ROM FIX BRACKET	33-M40AZ-010	
3	DVD 5 1/4" 8X 12.7mm SDR-083 F/V-MH12 QSI	85-7078X-C03	
4	QSI 8X DVD BEZEL MODULE	42-M40AV-100	
5	SCREW M1.7*0.64*3.8L B BZ ICT	35-46117-3R8	

Hard Disk Drive (M400A/M40AE/M400G/M40GE)

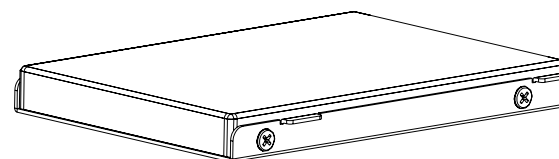
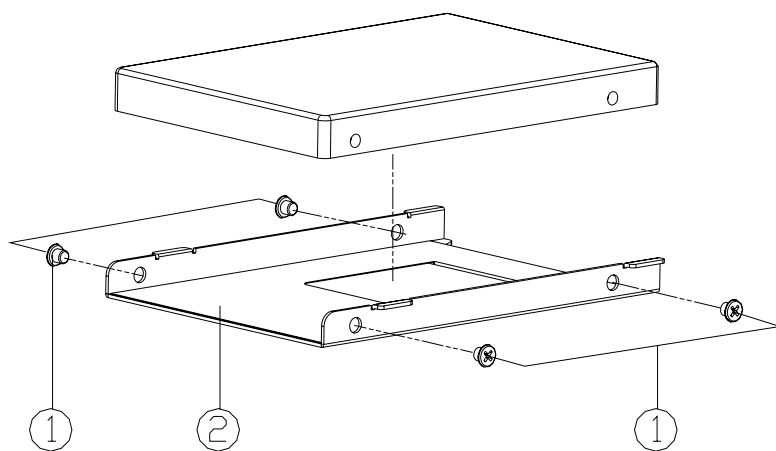

Figure A - 13
HDD Drive
(M400A/M40AE/
M400G/M40GE)

ITEM	PART NAME	PART NO	REMARK
1	SCREW M3*2.5L KI NI ICT NY	35-B1130-2R5	
2	HDD CASE MODULE(METAL)	33-M40AI-100	

A.Part Lists

Appendix B: Schematic Diagrams

This appendix has circuit diagrams of the *M400A/M400G/M40AE/M40GE* notebook's PCB's. The following table indicates where to find the appropriate schematic diagram.

Diagram - Page	Diagram - Page
<i>System Block Diagram - Page B - 2</i>	<i>TI - 1394A (43AB21) - Page B - 20</i>
<i>CLOCK GENERATOR - Page B - 3</i>	<i>CON; MINIPCI - Page B - 21</i>
<i>CPU - 1 - Page B - 4</i>	<i>PCMCIA (1620) - Page B - 22</i>
<i>CPU - 2 - Page B - 5</i>	<i>PCMCIA SOCKET - Page B - 23</i>
<i>ALVISO - 1 - Page B - 6</i>	<i>HITACHI H8 - Page B - 24</i>
<i>ALVISO - 2 - Page B - 7</i>	<i>AUDIO - Page B - 25</i>
<i>ALVISO - 3 - Page B - 8</i>	<i>+VS; PWRBTN - Page B - 26</i>
<i>ALVISO - 4 - Page B - 9</i>	<i>LED; NS87383 - Page B - 27</i>
<i>VGA CARD CONNECTOR - Page B - 10</i>	<i>FAN CONN, LPC ROM - Page B - 28</i>
<i>DDR2 - DIMM1 - Page B - 11</i>	<i>5V, 3.3V, +1.5V - Page B - 29</i>
<i>DDR2 - DIMM2 - Page B - 12</i>	<i>CHARGER - Page B - 30</i>
<i>ICH6 - 1 - Page B - 13</i>	<i>TPS51116 - Page B - 31</i>
<i>ICH6 - 2 - Page B - 14</i>	<i>VCORE+ 1.05V - Page B - 32</i>
<i>ICH6 - 3 - Page B - 15</i>	<i>CARD READER BOARD - Page B - 33</i>
<i>HDD & CD ROM - Page B - 16</i>	<i>CLICK BOARD - Page B - 34</i>
<i>USB & CCD CONN - Page B - 17</i>	<i>LED BOARD - Page B - 35</i>
<i>MDC, BT, CCD - Page B - 18</i>	<i>RJ11 BOARD - Page B - 36</i>
<i>PCI-E LAN - Page B - 19</i>	<i>SRS AP8202 - Page B - 37</i>

Table B - 1
Schematic Diagrams

System Block Diagram

BLOCK DIAGRAM

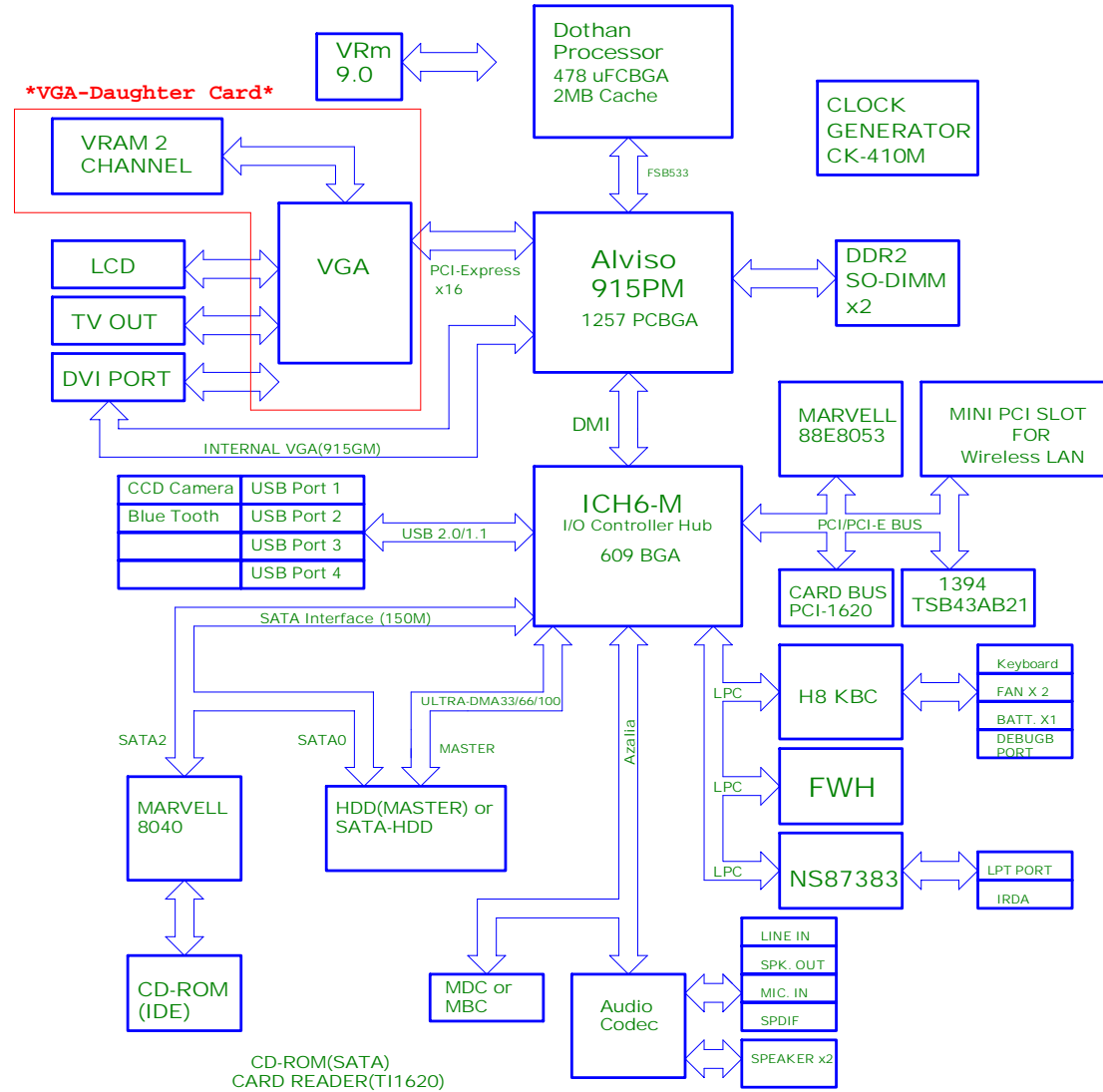

Sheet 1 of 42
System Block
Diagram

CLOCK GENERATOR

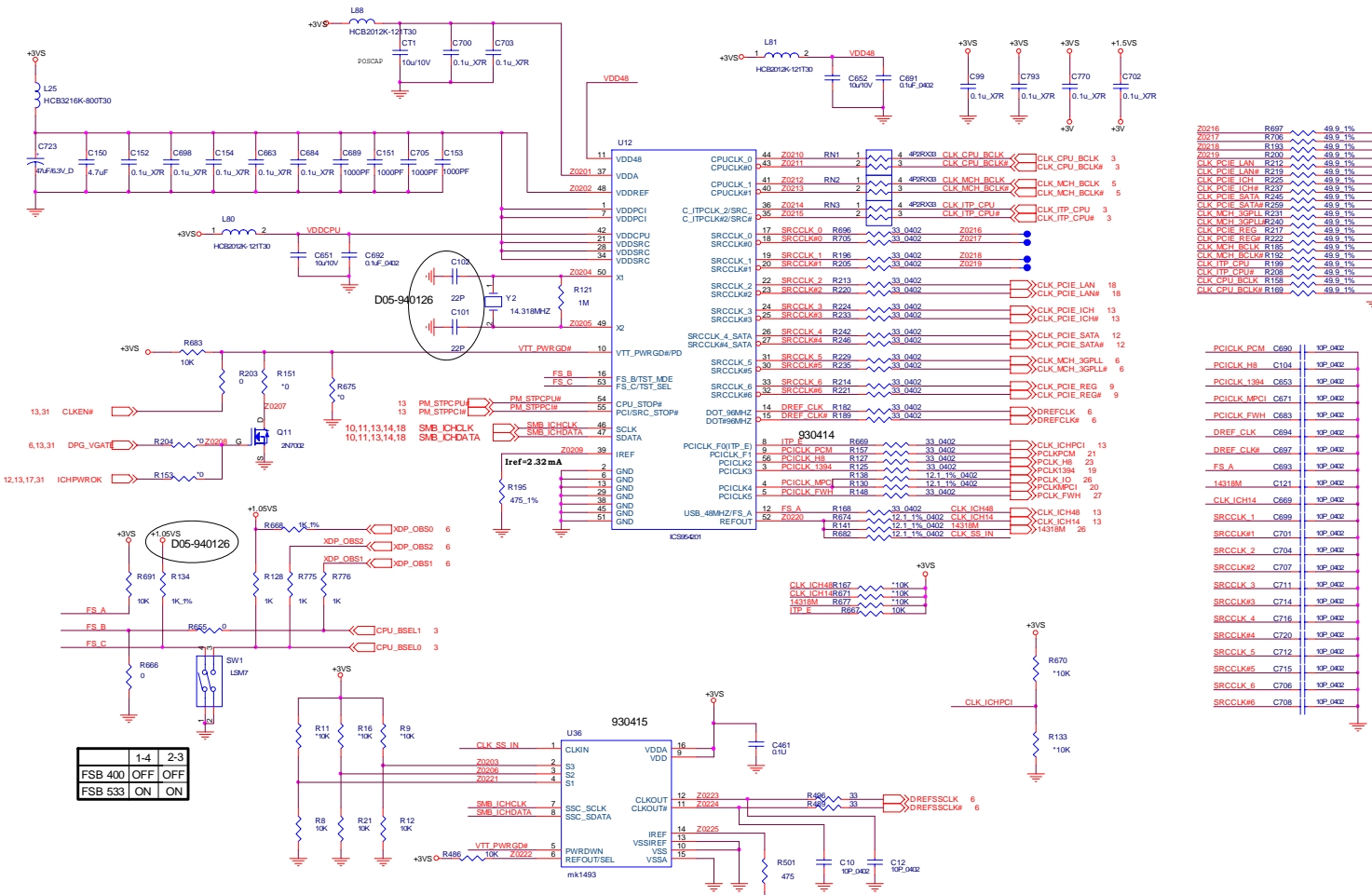

Z0216	R697	49.9 1%
Z0217	R706	49.9 1%
Z0218	R185	49.9 1%
Z0219	R200	49.9 1%
Z0220	R212	49.9 1%
Z0221	R215	49.9 1%
Z0222	R226	49.9 1%
Z0223	R229	49.9 1%
Z0224	R245	49.9 1%
Z0225	R259	49.9 1%
Z0226	R291	49.9 1%
Z0227	R217	49.9 1%
Z0228	R222	49.9 1%
Z0229	R188	49.9 1%
Z0230	R190	49.9 1%
Z0231	R208	49.9 1%
Z0232	R189	49.9 1%
Z0233	R189	49.9 1%
Z0234	R189	49.9 1%
Z0235	R189	49.9 1%
Z0236	R189	49.9 1%
Z0237	R189	49.9 1%
Z0238	R189	49.9 1%
Z0239	R189	49.9 1%
Z0240	R189	49.9 1%
Z0241	R189	49.9 1%
Z0242	R189	49.9 1%
Z0243	R189	49.9 1%
Z0244	R189	49.9 1%
Z0245	R189	49.9 1%
Z0246	R189	49.9 1%
Z0247	R189	49.9 1%
Z0248	R189	49.9 1%
Z0249	R189	49.9 1%
Z0250	R189	49.9 1%
Z0251	R189	49.9 1%
Z0252	R189	49.9 1%
Z0253	R189	49.9 1%
Z0254	R189	49.9 1%
Z0255	R189	49.9 1%
Z0256	R189	49.9 1%
Z0257	R189	49.9 1%
Z0258	R189	49.9 1%
Z0259	R189	49.9 1%
Z0260	R189	49.9 1%
Z0261	R189	49.9 1%
Z0262	R189	49.9 1%
Z0263	R189	49.9 1%
Z0264	R189	49.9 1%
Z0265	R189	49.9 1%
Z0266	R189	49.9 1%
Z0267	R189	49.9 1%
Z0268	R189	49.9 1%
Z0269	R189	49.9 1%
Z0270	R189	49.9 1%
Z0271	R189	49.9 1%
Z0272	R189	49.9 1%
Z0273	R189	49.9 1%
Z0274	R189	49.9 1%
Z0275	R189	49.9 1%
Z0276	R189	49.9 1%
Z0277	R189	49.9 1%
Z0278	R189	49.9 1%
Z0279	R189	49.9 1%
Z0280	R189	49.9 1%
Z0281	R189	49.9 1%
Z0282	R189	49.9 1%
Z0283	R189	49.9 1%
Z0284	R189	49.9 1%
Z0285	R189	49.9 1%
Z0286	R189	49.9 1%
Z0287	R189	49.9 1%
Z0288	R189	49.9 1%
Z0289	R189	49.9 1%
Z0290	R189	49.9 1%
Z0291	R189	49.9 1%
Z0292	R189	49.9 1%
Z0293	R189	49.9 1%
Z0294	R189	49.9 1%
Z0295	R189	49.9 1%
Z0296	R189	49.9 1%
Z0297	R189	49.9 1%
Z0298	R189	49.9 1%
Z0299	R189	49.9 1%
Z0300	R189	49.9 1%
Z0301	R189	49.9 1%
Z0302	R189	49.9 1%
Z0303	R189	49.9 1%
Z0304	R189	49.9 1%
Z0305	R189	49.9 1%
Z0306	R189	49.9 1%
Z0307	R189	49.9 1%
Z0308	R189	49.9 1%
Z0309	R189	49.9 1%
Z0310	R189	49.9 1%
Z0311	R189	49.9 1%
Z0312	R189	49.9 1%
Z0313	R189	49.9 1%
Z0314	R189	49.9 1%
Z0315	R189	49.9 1%
Z0316	R189	49.9 1%
Z0317	R189	49.9 1%
Z0318	R189	49.9 1%
Z0319	R189	49.9 1%
Z0320	R189	49.9 1%
Z0321	R189	49.9 1%
Z0322	R189	49.9 1%
Z0323	R189	49.9 1%
Z0324	R189	49.9 1%
Z0325	R189	49.9 1%
Z0326	R189	49.9 1%
Z0327	R189	49.9 1%
Z0328	R189	49.9 1%
Z0329	R189	49.9 1%
Z0330	R189	49.9 1%
Z0331	R189	49.9 1%
Z0332	R189	49.9 1%
Z0333	R189	49.9 1%
Z0334	R189	49.9 1%
Z0335	R189	49.9 1%
Z0336	R189	49.9 1%
Z0337	R189	49.9 1%
Z0338	R189	49.9 1%
Z0339	R189	49.9 1%
Z0340	R189	49.9 1%
Z0341	R189	49.9 1%
Z0342	R189	49.9 1%
Z0343	R189	49.9 1%
Z0344	R189	49.9 1%
Z0345	R189	49.9 1%
Z0346	R189	49.9 1%
Z0347	R189	49.9 1%
Z0348	R189	49.9 1%
Z0349	R189	49.9 1%
Z0350	R189	49.9 1%
Z0351	R189	49.9 1%
Z0352	R189	49.9 1%
Z0353	R189	49.9 1%
Z0354	R189	49.9 1%
Z0355	R189	49.9 1%
Z0356	R189	49.9 1%
Z0357	R189	49.9 1%
Z0358	R189	49.9 1%
Z0359	R189	49.9 1%
Z0360	R189	49.9 1%
Z0361	R189	49.9 1%
Z0362	R189	49.9 1%
Z0363	R189	49.9 1%
Z0364	R189	49.9 1%
Z0365	R189	49.9 1%
Z0366	R189	49.9 1%
Z0367	R189	49.9 1%
Z0368	R189	49.9 1%
Z0369	R189	49.9 1%
Z0370	R189	49.9 1%
Z0371	R189	49.9 1%
Z0372	R189	49.9 1%
Z0373	R189	49.9 1%
Z0374	R189	49.9 1%
Z0375	R189	49.9 1%
Z0376	R189	49.9 1%
Z0377	R189	49.9 1%
Z0378	R189	49.9 1%
Z0379	R189	49.9 1%
Z0380	R189	49.9 1%
Z0381	R189	49.9 1%
Z0382	R189	49.9 1%
Z0383	R189	49.9 1%
Z0384	R189	49.9 1%
Z0385	R189	49.9 1%
Z0386	R189	49.9 1%
Z0387	R189	49.9 1%
Z0388	R189	49.9 1%
Z0389	R189	49.9 1%
Z0390	R189	49.9 1%
Z0391	R189	49.9 1%
Z0392	R189	49.9 1%
Z0393	R189	49.9 1%
Z0394	R189	49.9 1%
Z0395	R189	49.9 1%
Z0396	R189	49.9 1%
Z0397	R189	49.9 1%
Z0398	R189	49.9 1%
Z0399	R189	49.9 1%
Z0400	R189	49.9 1%
Z0401	R189	49.9 1%
Z0402	R189	49.9 1%
Z0403	R189	49.9 1%
Z0404	R189	49.9 1%
Z0405	R189	49.9 1%
Z0406	R189	49.9 1%
Z0407	R189	49.9 1%
Z0408	R189	49.9 1%
Z0409	R189	49.9 1%
Z0410	R189	49.9 1%
Z0411	R189	49.9 1%
Z0412	R189	49.9 1%
Z0413	R189	49.9 1%
Z0414	R189	49.9 1%
Z0415	R189	49.9 1%
Z0416	R189	49.9 1%
Z0417	R189	49.9 1%
Z0418	R189	49.9 1%
Z0419	R189	49.9 1%
Z0420	R189	49.9 1%
Z0421	R189	49.9 1%
Z0422	R189	49.9 1%
Z0423	R189	49.9 1%
Z0424	R189	49.9 1%
Z0425	R189	49.9 1%
Z0426	R189	49.9 1%
Z0427	R189	49.9 1%
Z0428	R189	49.9 1%
Z0429	R189	49.9 1%
Z0430	R189	49.9 1%
Z0431	R189	49.9 1%
Z0432	R189	49.9 1%
Z0433	R189	49.9 1%
Z0434	R189	49.9 1%
Z0435	R189	49.9 1%
Z0436	R189	49.9 1%
Z0437	R189	49.9 1%
Z0438	R189	49.9 1%
Z0439	R189	49.9 1%
Z0440	R189	49.9 1%
Z0441	R189	49.9 1%
Z0442	R189	49.9 1%
Z0443	R189	49.9 1%
Z0444	R189	49.9 1%
Z0445	R189	49.9 1%
Z0446	R189	49.9 1%
Z0447	R189	49.9 1%
Z0448	R189	49.9 1%
Z0449	R189	49.9 1%
Z0450	R189	49.9 1%
Z0451	R189	49.9 1%
Z0452	R189	49.9 1%
Z0453	R189	49.9 1%
Z0454	R189	49.9 1%
Z0455	R189	49.9 1%
Z0456	R189	49.9 1%
Z0457	R189	49.9 1%
Z0458	R189	49.9 1%
Z0459	R189	49.9 1%
Z0460	R189	49.9 1%
Z0461	R189	49.9 1%
Z0462	R189	49.9 1%
Z0463	R189	49.9 1%
Z0464	R189	49.9 1%
Z0465	R189	49.9 1%
Z0466	R189	49.9 1%
Z0467	R189	49.9 1%
Z0468	R189	49.9 1%
Z0469	R189	49.9 1%
Z0470	R189	49.9 1%
Z0471	R189	49.9 1%
Z0472	R189	49.9 1%
Z0473	R189	49.9 1%
Z0474	R189	49.9 1%
Z0475	R189	49.9 1%
Z0476	R189	49.9 1%
Z0477	R189	49.9 1%
Z0478	R189	49.9 1%
Z0479	R189	49.9 1%
Z0480	R189	49.9 1%
Z0481	R189	49.9 1%
Z0482	R189	49.9 1%
Z0483	R189	49.9 1%
Z0484	R189	49.9 1%
Z0485	R189	49.9 1%
Z0486	R189	49.9 1%
Z0487	R189	49.9 1%
Z0488	R189	49.9 1%
Z0489	R189	49.9 1%
Z0490	R189	49.9 1%
Z0491	R189	49.9 1%
Z0492	R189	49.9 1%
Z0493	R189	49.9 1%
Z0494	R189	49.9 1%
Z0495	R189	49.9 1%
Z0496	R189	49.9 1%
Z0497	R189	49.9 1%
Z0498	R189	49.9 1%
Z0499	R189	49.9 1%
Z0500	R189	49.9 1%
Z0501	R189	49.9 1%
Z0502	R189	49.9 1%
Z0503	R189	49.9 1%
Z0504	R189	49.9 1%
Z0505	R189	49.9 1%
Z0506	R189	49.9 1%
Z0507	R189	49.9 1%
Z0508	R189	49.9 1%
Z0509	R189	49.9 1%
Z0510	R189	49.9 1%
Z0511	R189	49.9 1%
Z0512	R189	49.9 1%
Z0513	R189	49.9 1%
Z0514	R189	49.9 1%
Z0515	R189	49.9 1%
Z0516	R189	49.9 1%
Z0517	R189	49.9 1%
Z0518	R189	49.9 1%
Z0519	R189	49.9 1%
Z0520	R189	49.9 1%
Z0521	R189	49.9 1%
Z0522	R189	49.9 1%
Z0523	R189	49.9 1%
Z0524	R189	49.9 1%
Z0525	R189	49.9 1%
Z0526	R189	49.9 1%
Z0527	R189	49.9 1%
Z0528	R189	49.9 1%
Z0529	R189	49.9 1%
Z0530	R189	49.9 1%
Z0531	R189	49.9 1%
Z0532	R189	49.9 1%
Z0533	R189	49.9 1%
Z0534	R189	49.9 1%
Z0535	R189	49.9 1%
Z0536	R189	49.9 1%
Z0537	R189	49.9 1%
Z0538	R189	49.9 1%
Z0539	R189	49.9 1%
Z0540	R189	49.9 1%
Z0541	R189	49.9 1%
Z0542	R189	49.9 1%
Z0543	R189	49.9 1%
Z0544	R189	49.9 1%
Z0545	R189	49.9 1%
Z0546	R189	49.9 1%
Z0547	R189	49.9 1%
Z0548	R189	49.9 1%
Z0549	R189	49.9 1%
Z0550	R189	49.9 1%
Z0551	R189	49.9 1%
Z0552	R189	49.9 1%
Z0553	R189	49.9 1%
Z0554	R189	49.9 1%
Z0555	R189	49.9 1%
Z0556	R189	49.9 1%
Z0557	R189	49.9 1%
Z0558	R189	49.9 1%
Z0559	R189	49.9 1%
Z0560	R189	49.9 1%
Z0561	R189	49.9 1%
Z0562	R189	49.9 1%
Z0563	R189	49.9 1%
Z0564	R189	49.9 1%
Z0565	R189	49.9 1%
Z0566	R189	49.9 1%
Z0567	R189	49.9 1%
Z0568	R189	49.9 1%
Z0569	R189	49.9 1%
Z0570	R189	49.9 1%
Z0571	R189	49.9 1%</

CPU - 2

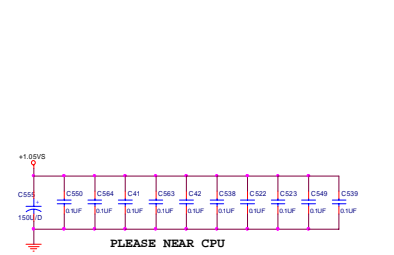
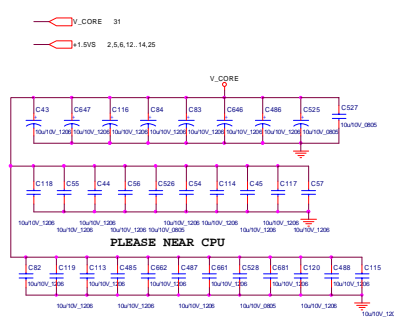
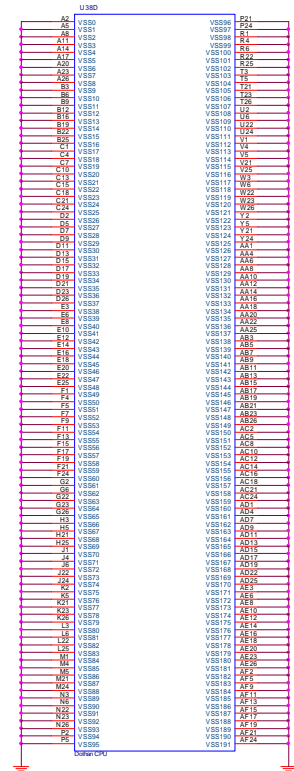
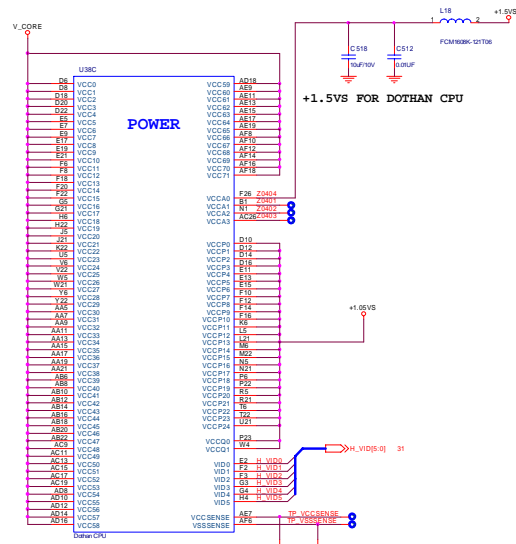

VID	Vcc	VID	Vcc
V	V	V	V
5	1.708	5	1.196
4	1.692	4	1.180
3	1.676	3	1.164
2	1.660	2	1.148
1	1.644	1	1.132
0	1.628	0	1.116
0	1.612	0	1.100
0	1.596	0	1.084
0	1.580	0	1.068
0	1.564	0	1.052
0	1.548	0	1.036
0	1.532	0	1.020
0	1.516	0	1.004
0	1.500	0	0.988
0	1.484	0	0.972
0	1.468	0	0.956
0	1.452	0	0.940
0	1.436	0	0.924
0	1.420	0	0.908
0	1.404	0	0.892
0	1.388	0	0.876
0	1.372	0	0.860
0	1.356	0	0.844
0	1.340	0	0.828
0	1.324	0	0.812
0	1.308	0	0.796
0	1.292	0	0.780
0	1.276	0	0.764
0	1.260	0	0.748
0	1.244	0	0.732
0	1.228	0	0.716
0	1.212	0	0.700

Sheet 5 of 36
CPU - 2

B.Schematic Diagrams

ALVISO - 3

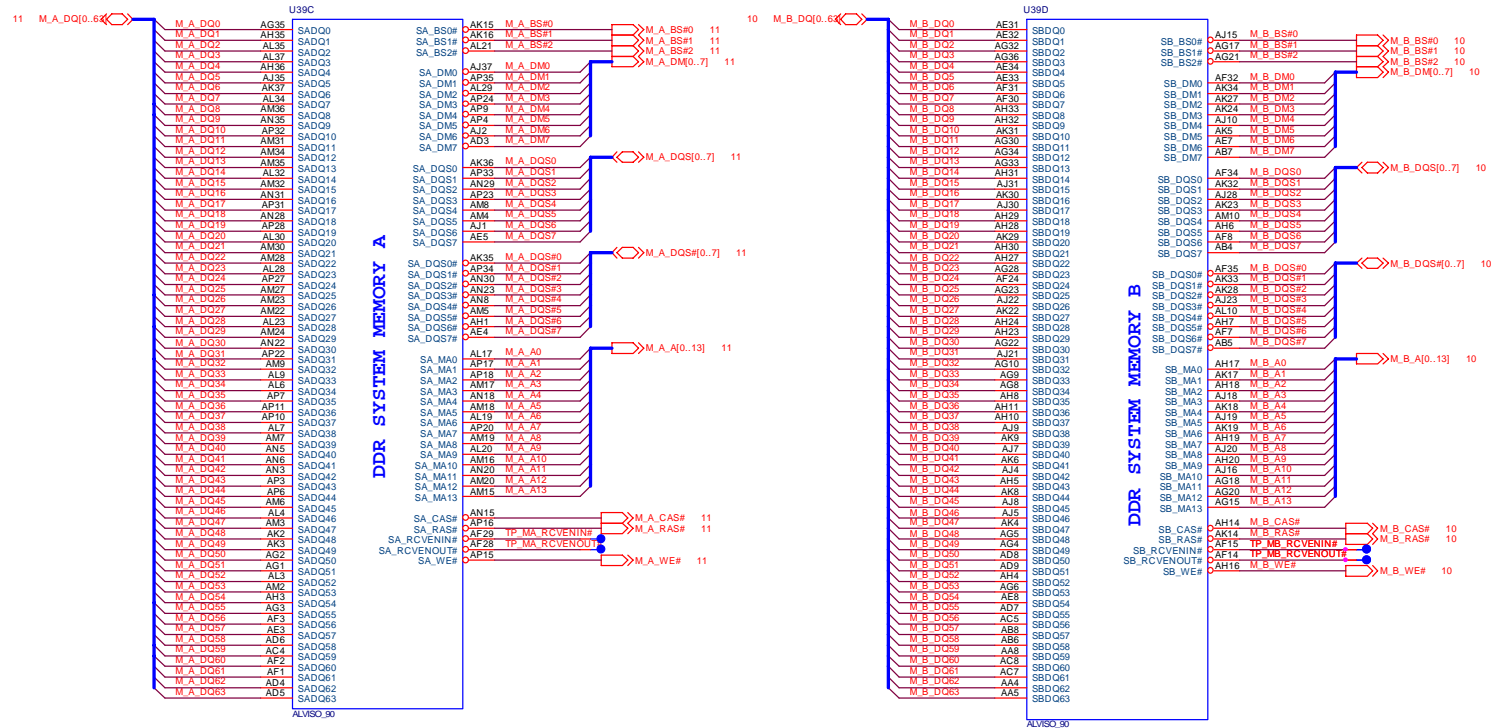

VGA CARD CONNECTOR

Sheet 10 of 36
VGA CARD
CONNECTOR

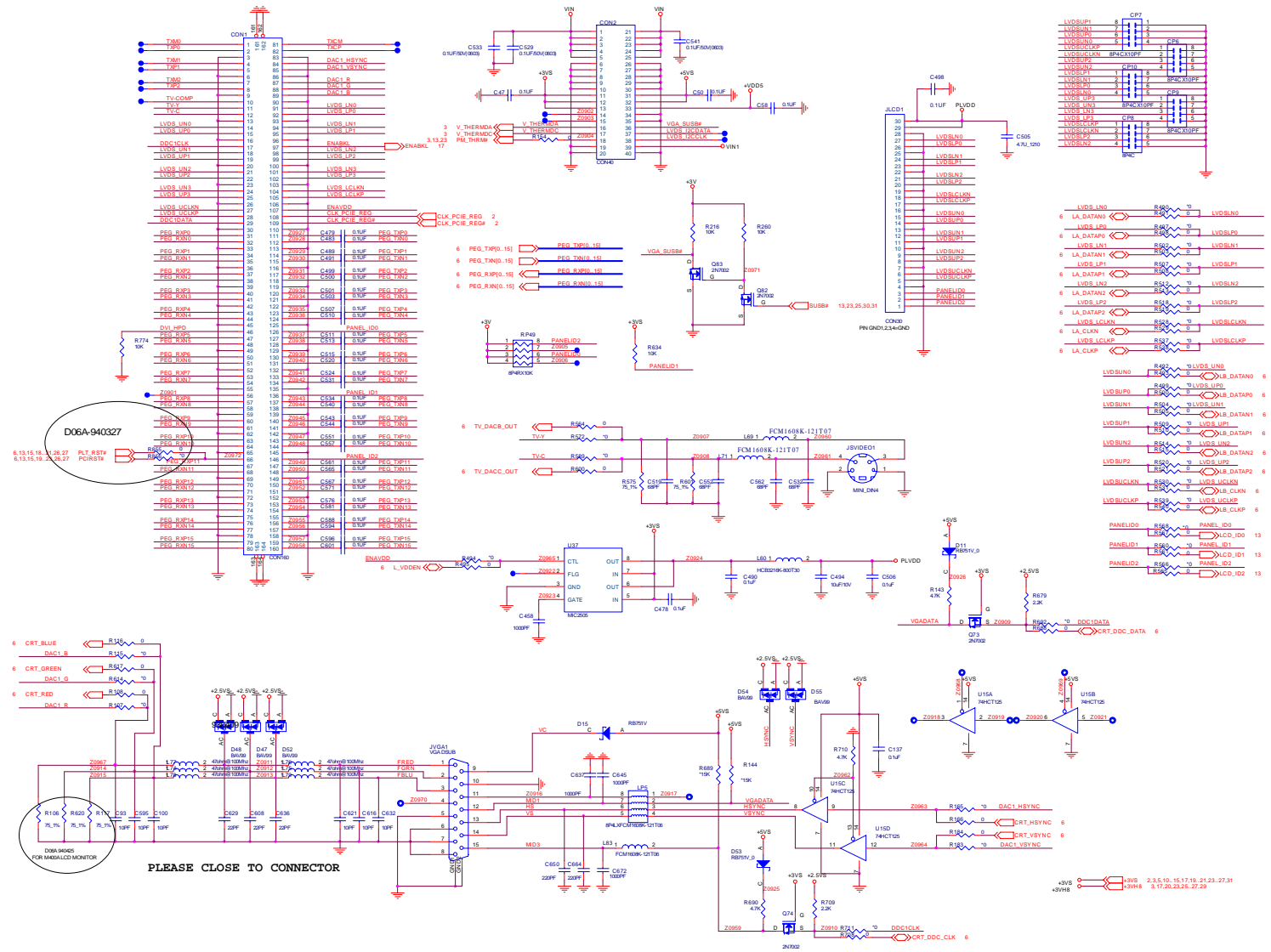

DDR2 - DIMM1

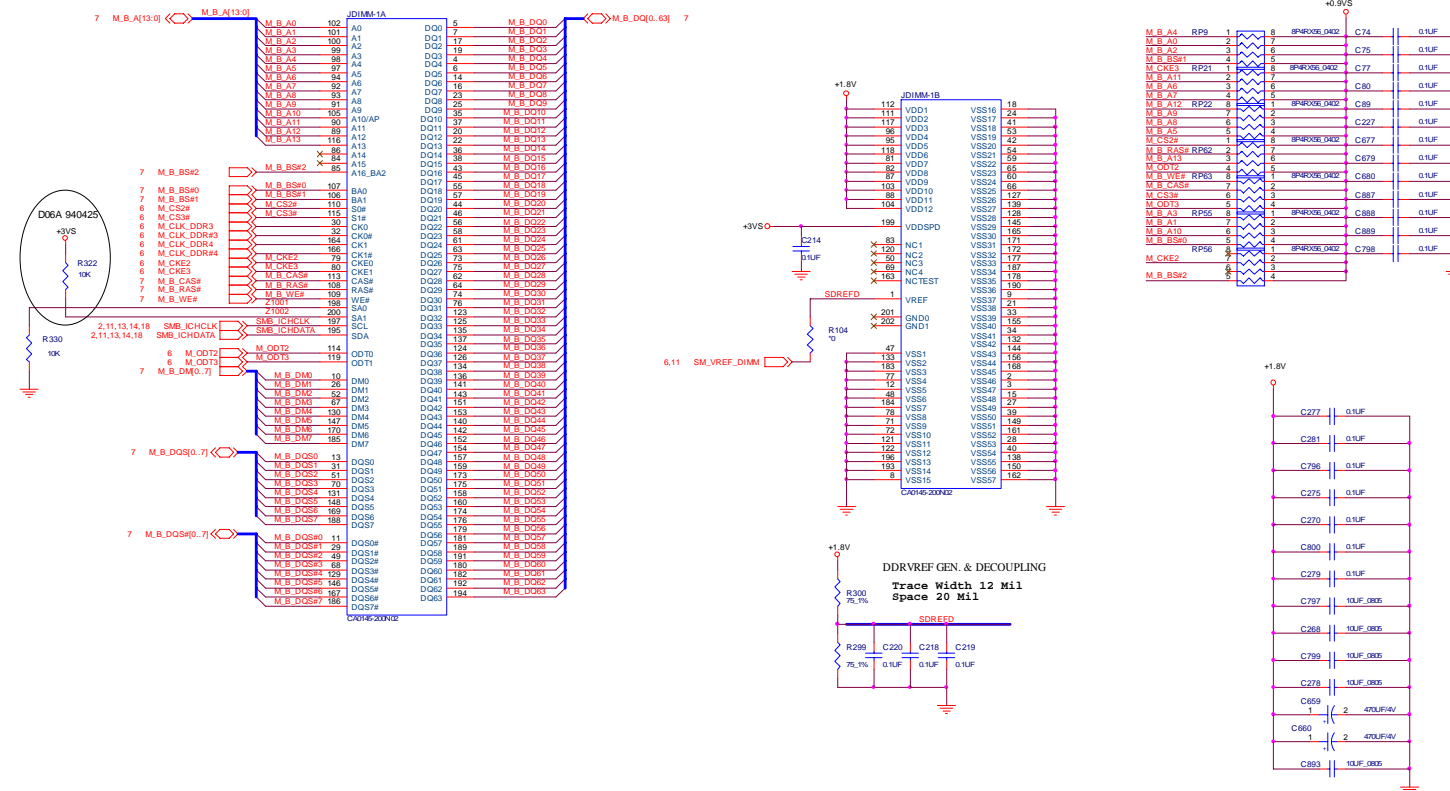

Sheet 11 of 38
DDR2 - DIMM1

B.Schematic Diagrams

ICH6 - 3

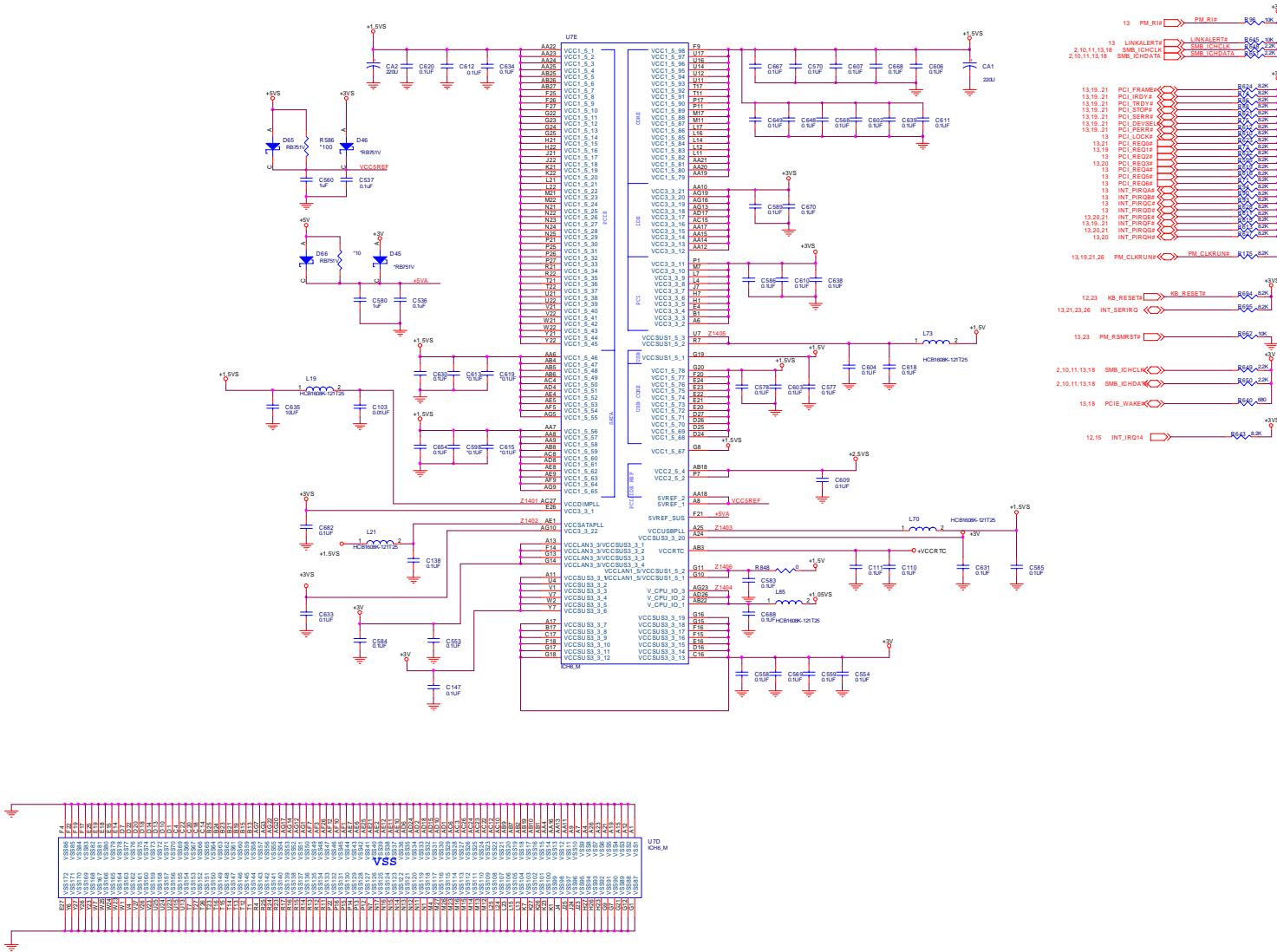

Sheet 15 of 36
ICH6 - 3

USB & CCD CONN

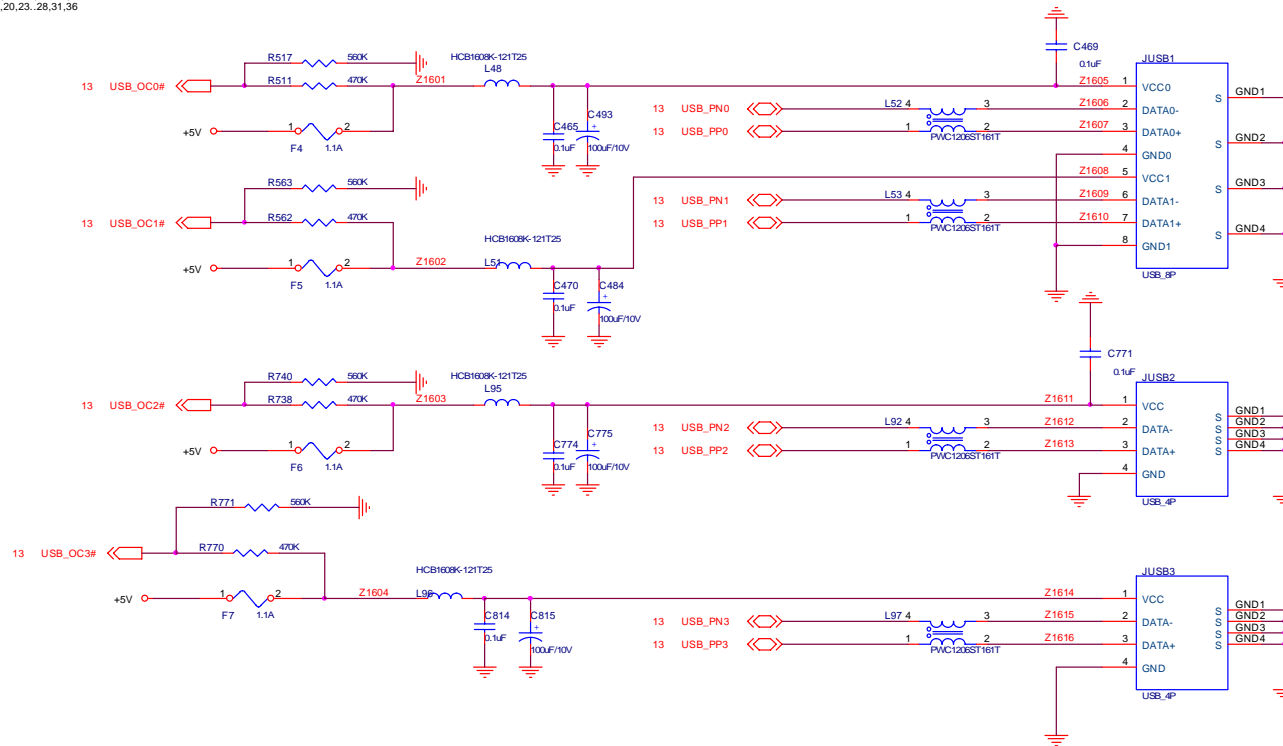

Sheet 17 of 36
USB & CCD CONN

B. Schematic Diagrams

Schematic Diagrams

MDC, BT, CCD

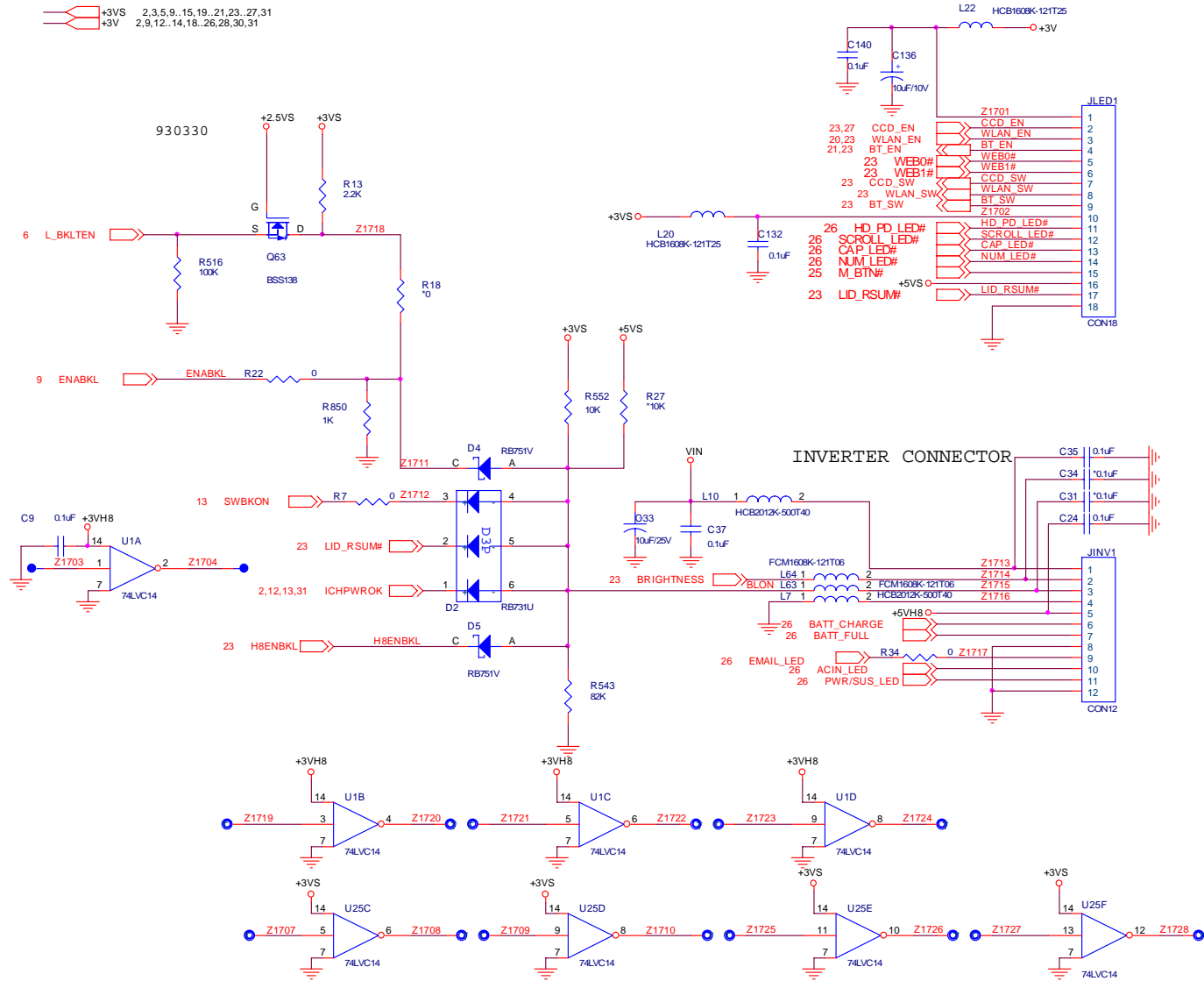

Sheet 18 of 36
MDC, BT, CCD

B.Schematic Diagrams

Schematic Diagrams

TI - 1394A (43AB21)

B.Schematic Diagrams

Sheet 20 of 36
TI 1394A (43AB21)

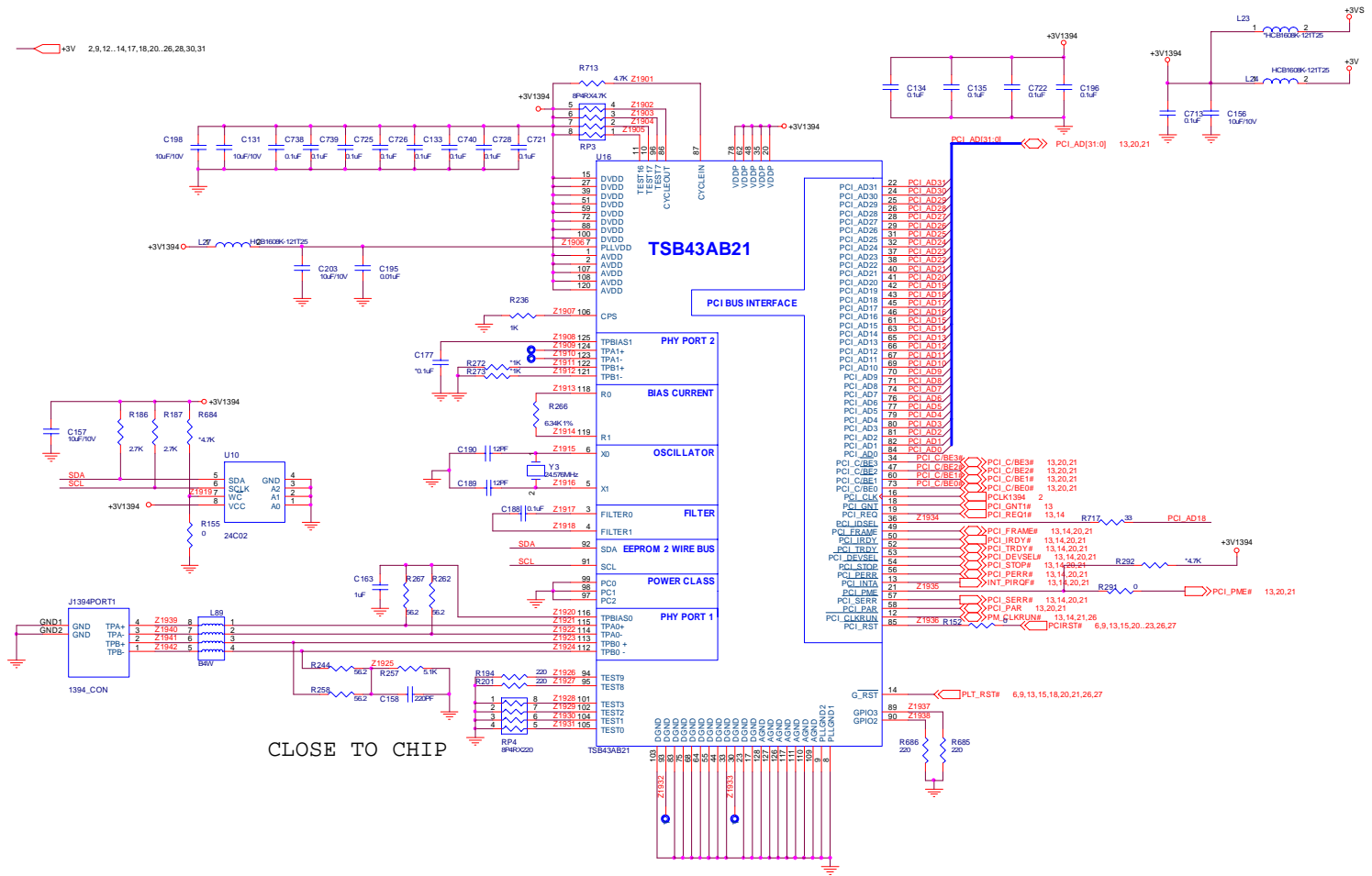

CON; MINIPCI

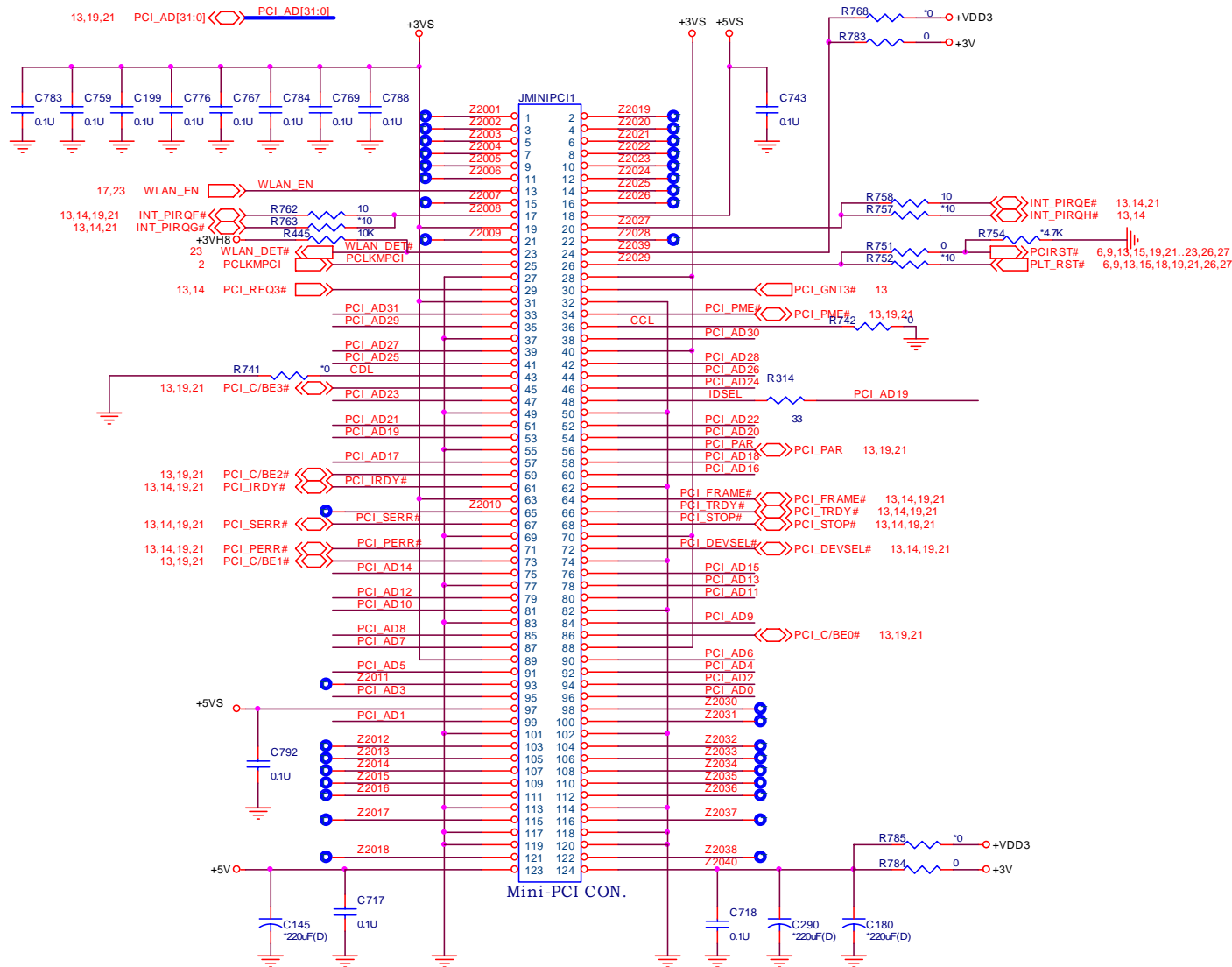

Sheet 21 of 36
CON; MINIPCI

PCMCIA SOCKET

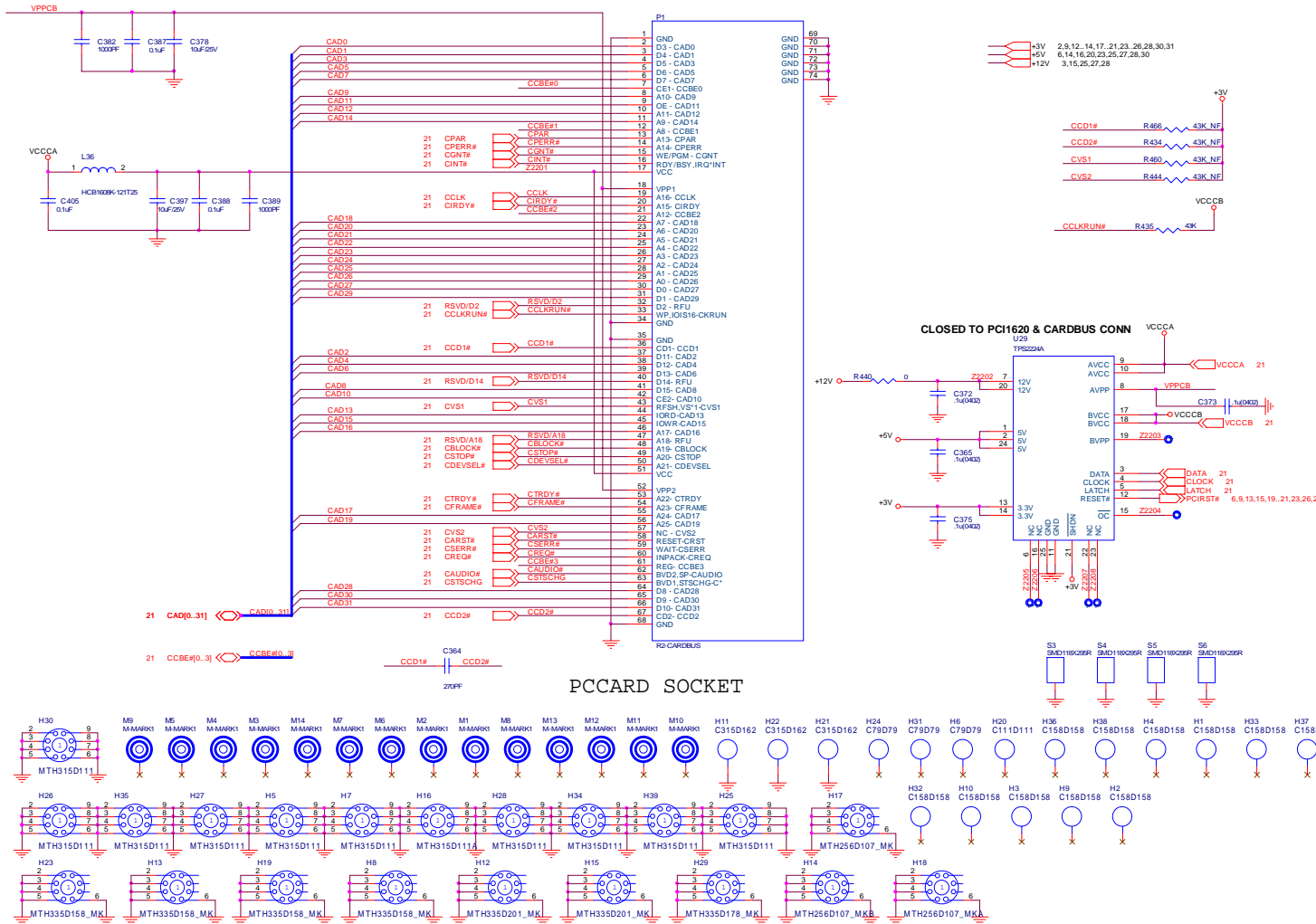

Schematic Diagrams

HITACHI H8

Sheet 24 of 36
HITACHI H8

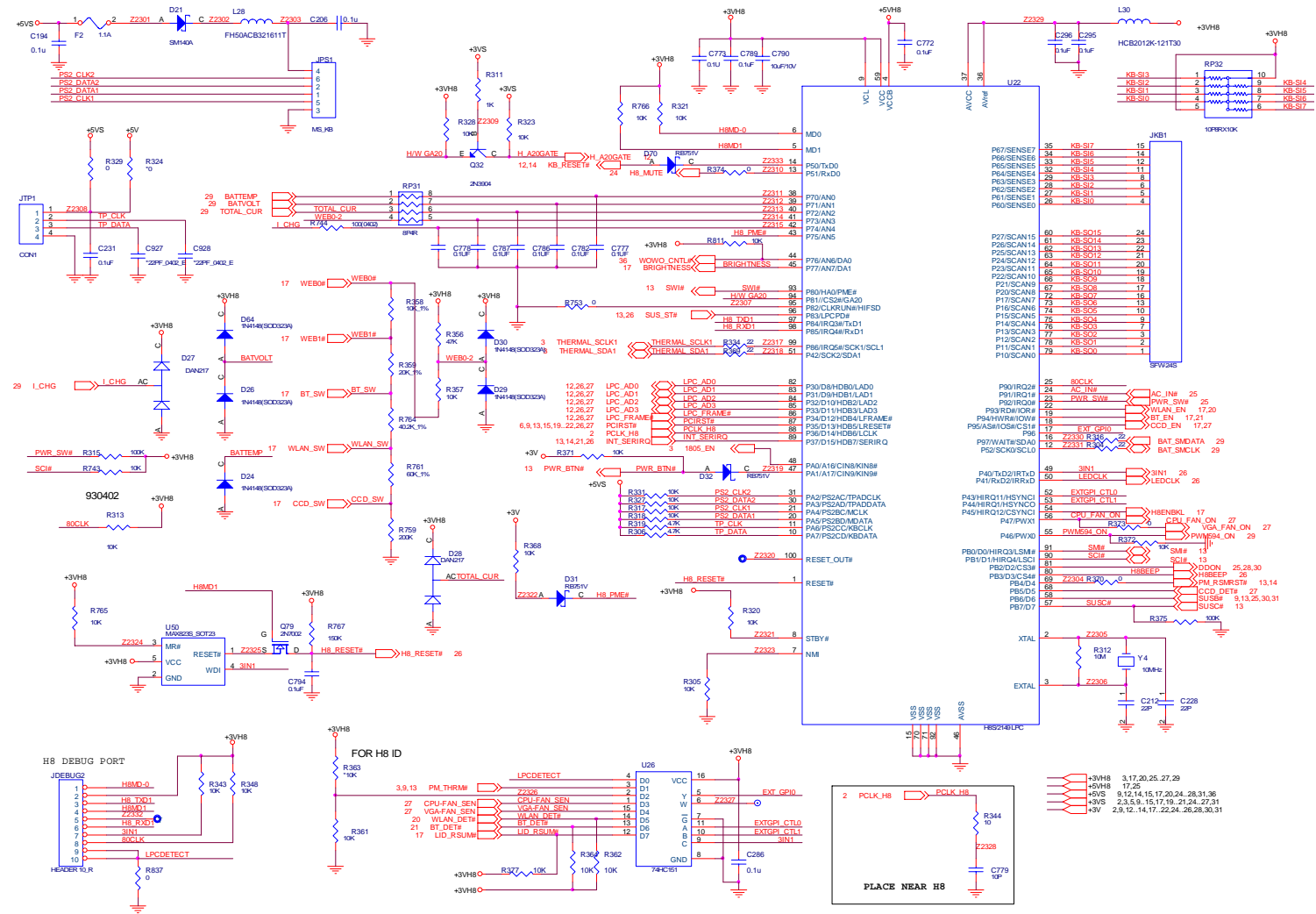

Schematic Diagrams

+VS; PWRBTN

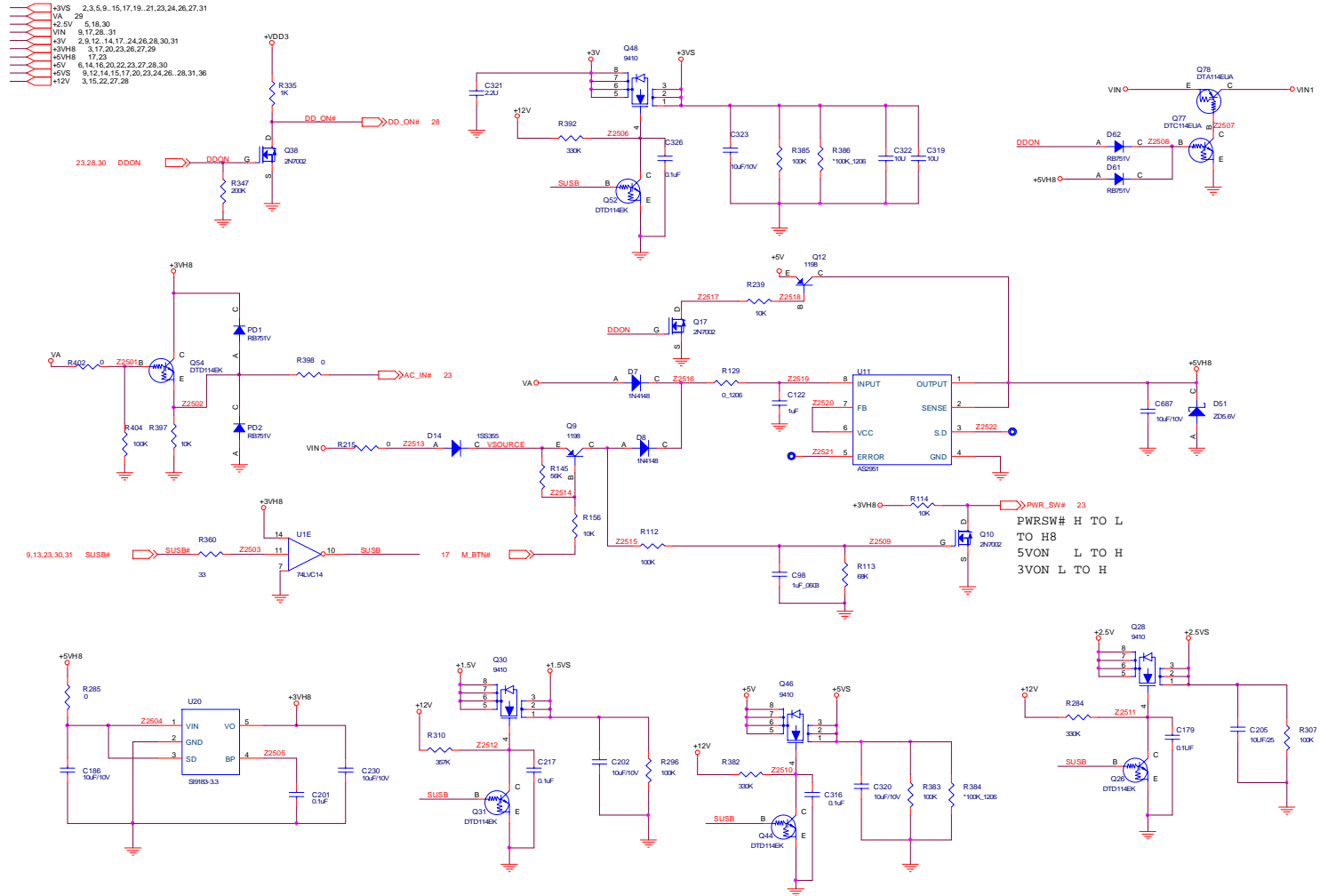

Sheet 26 of 36
+VS; PWRBTN

B.Schematic Diagrams

Schematic Diagrams

FAN CONN, LPC ROM

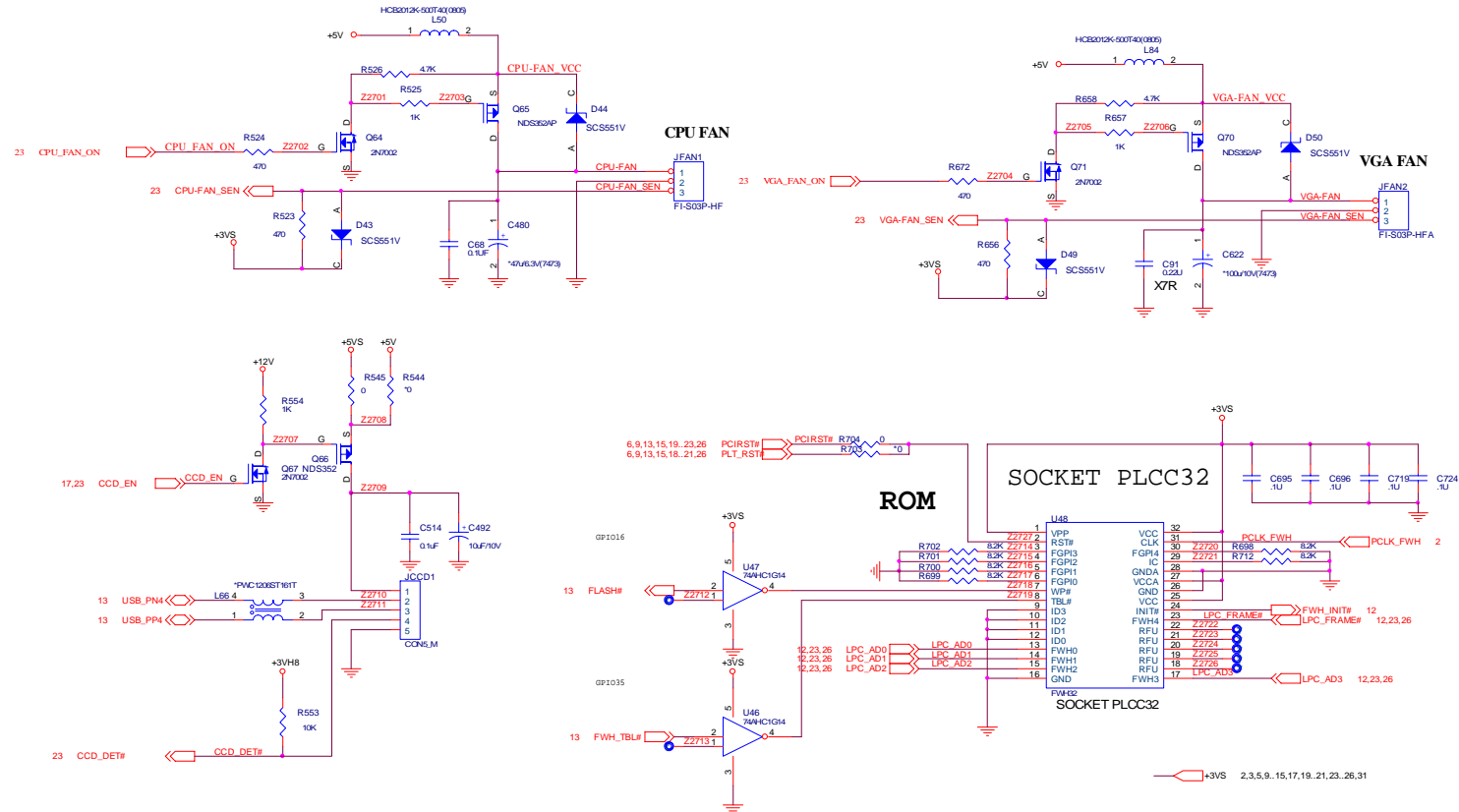

Sheet 28 of 36
FAN CONN, LPC
ROM

B.Schematic Diagrams

Schematic Diagrams

VCORE+ 1.05V

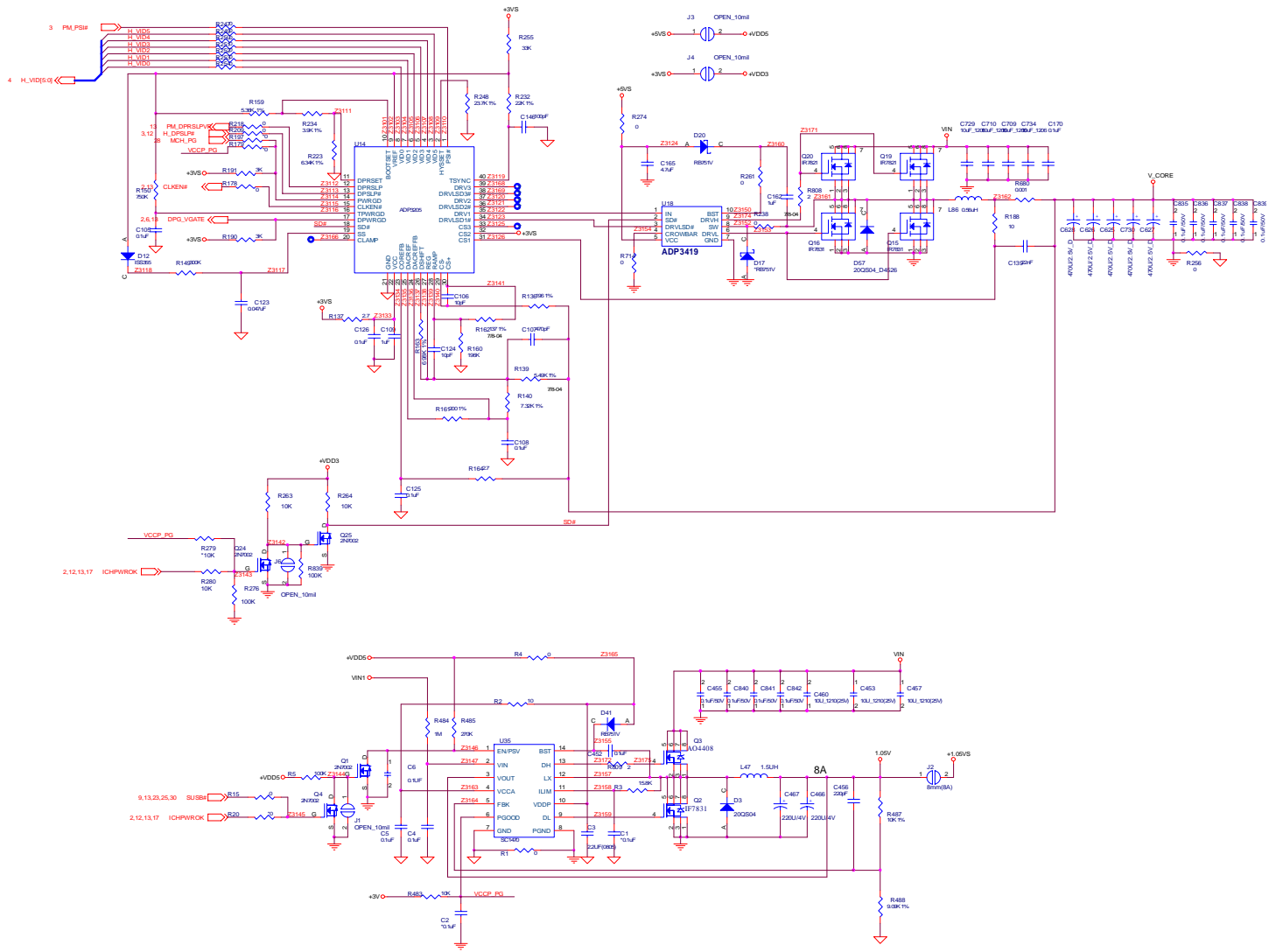

B.Schematic Diagrams

Sheet 32 of 36
VCORE+ 1.05V

CARD READER BOARD

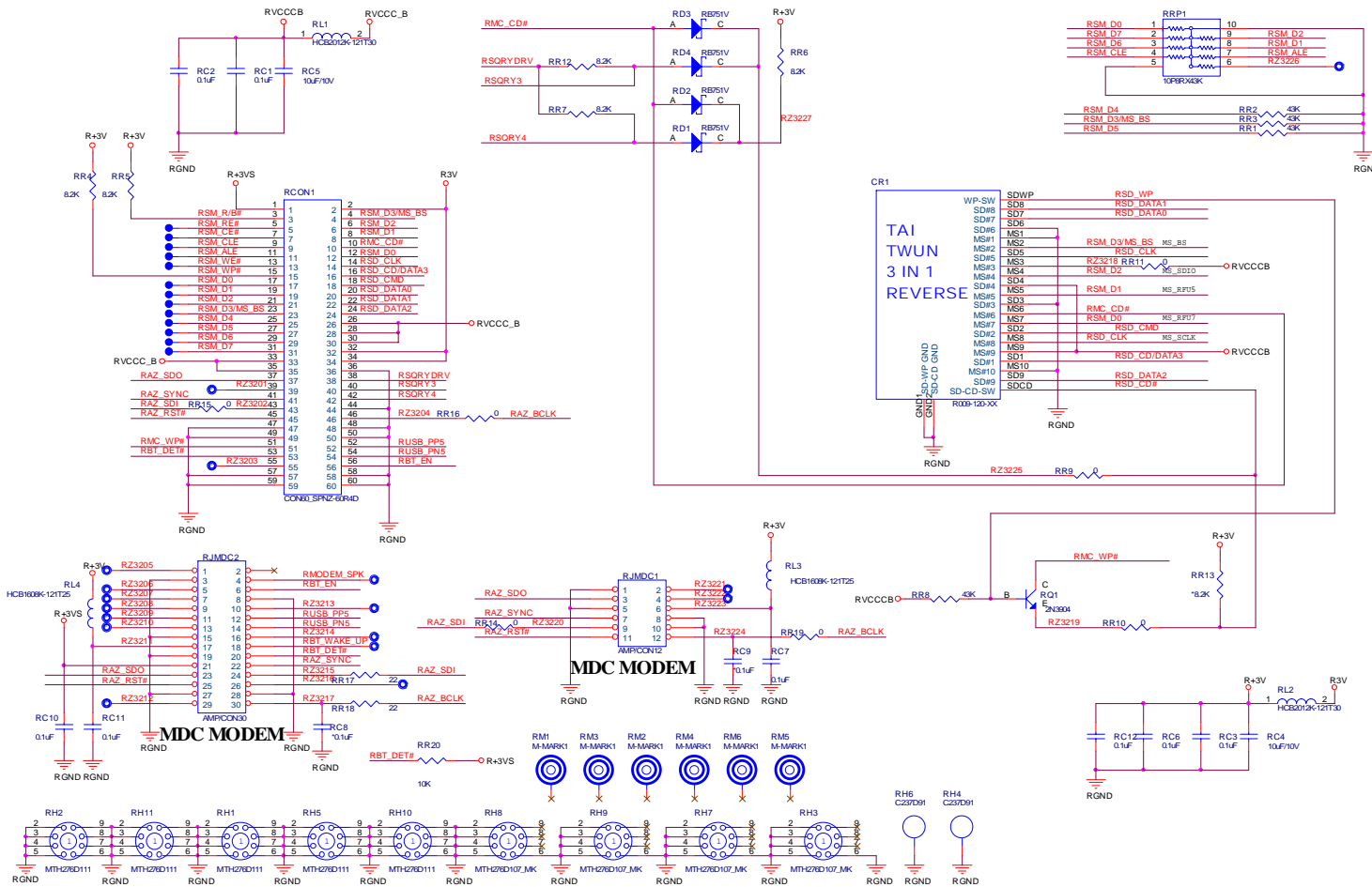

Sheet 33 of 36
CARD READER BOARD

B. Schematic Diagrams

CLICK BOARD

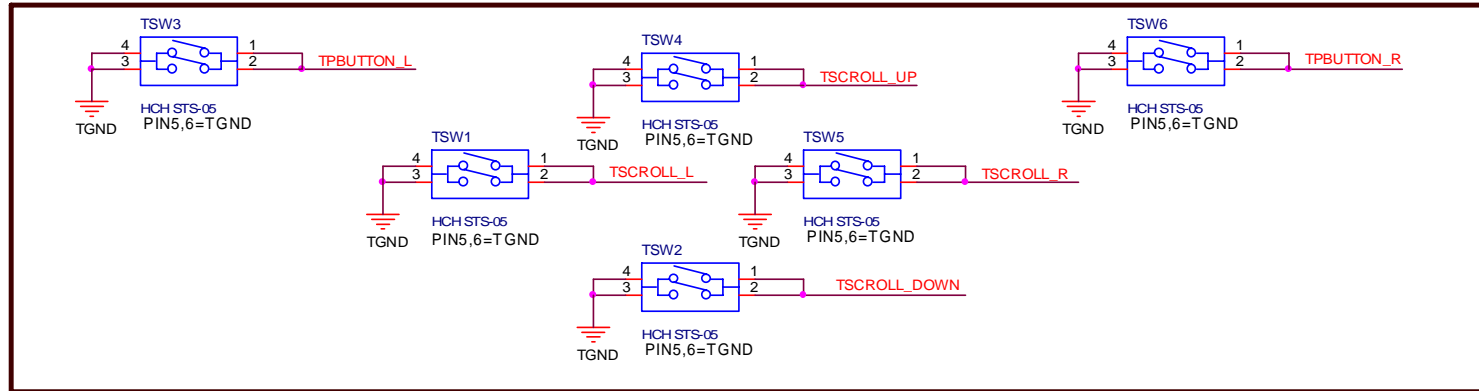

Sheet 34 of 36
CLICK BOARD

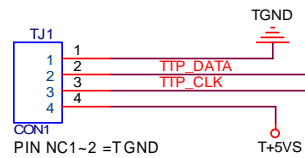
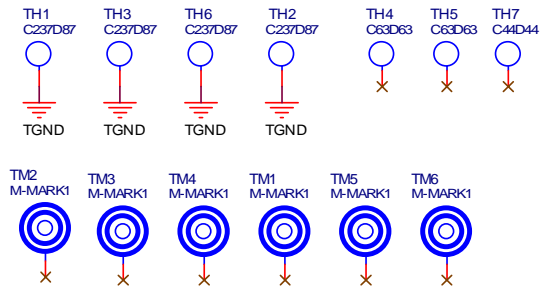
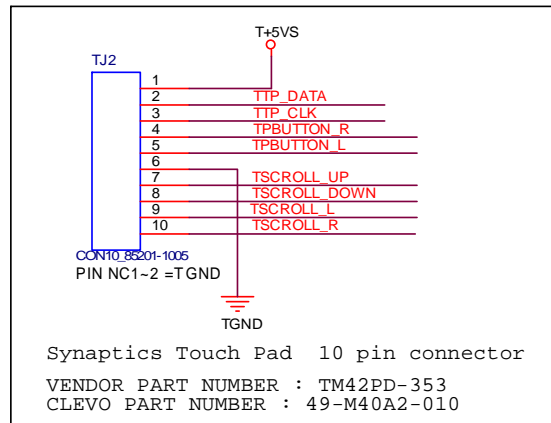

LED BOARD

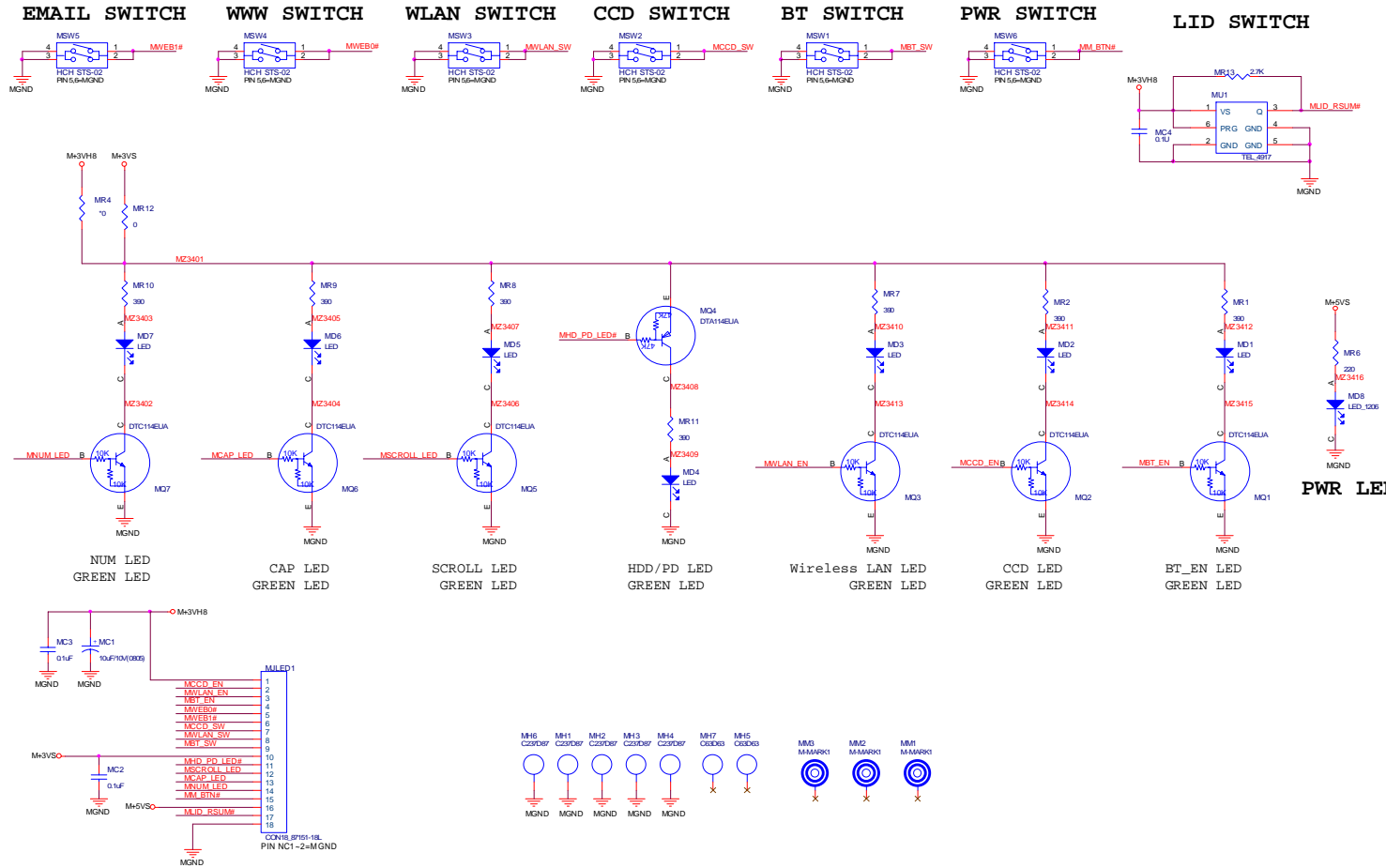

Sheet 35 of 36
LED BOARD

B.Schematic Diagrams

RJ11 BOARD

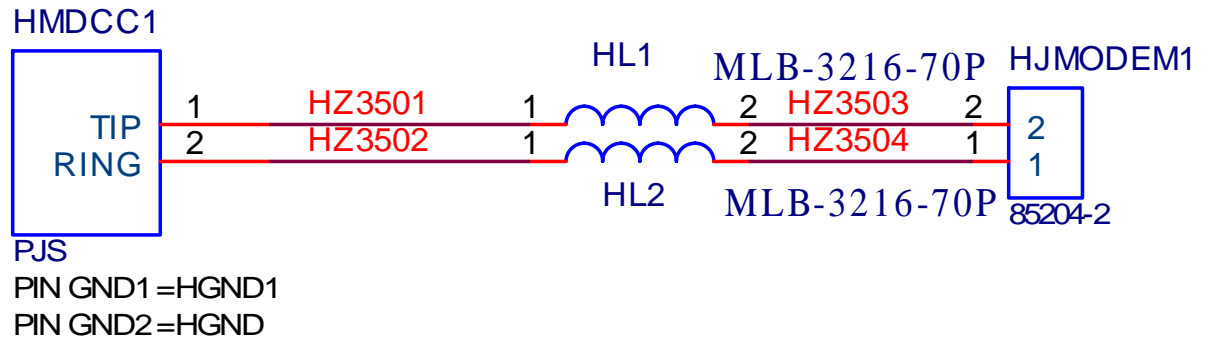

Sheet 36 of 36
RJ11 BOARD

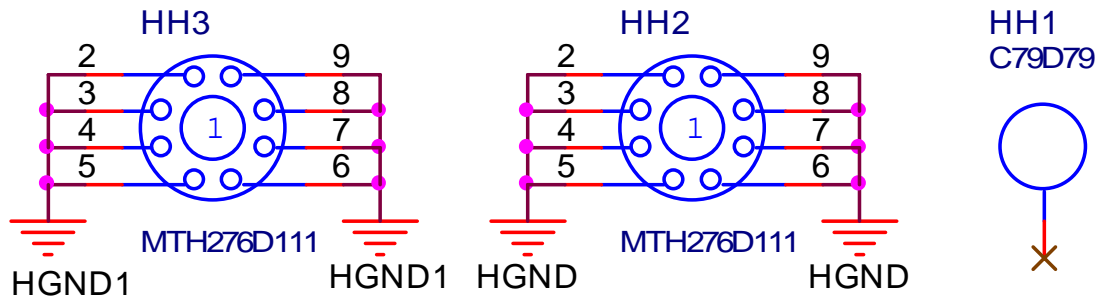

Schematic Diagrams

Appendix C: Switches

This appendix is about the system's switch setting. The switch (SW1) is used to change the CPU Clock Front Side Bus speed setting to either 400MHz or 533 MHz. Be sure to turn OFF the system before you perform any maintenance/up-grade procedure

Locating the Jumper Switch

1. Remove the keyboard and shielding plate (see [page 2 - 16](#) and [page 2 - 17](#)).
2. The Dip Switch (SW1) is at point **1** on the mainboard.

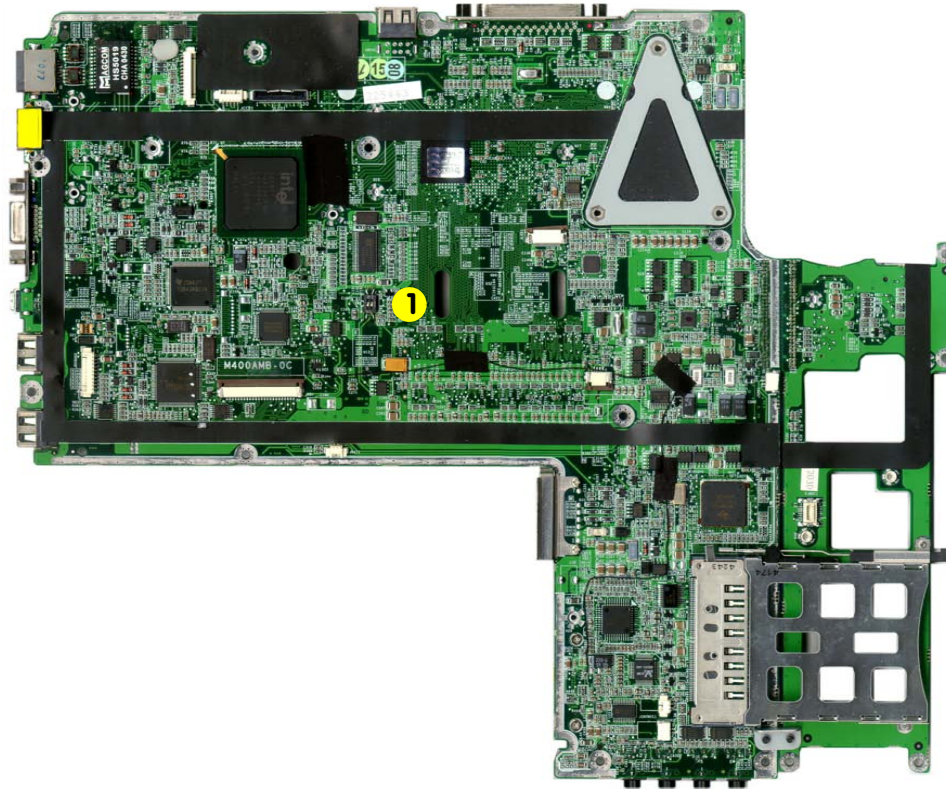

Figure C - 1
**Mainboard Switch
and Jumper
Location**

1. SW1

Settings

The following figure shows the location of the DIP Switch used for setting the CPU Clock Front Side Bus Speed.

Figure C - 2
**Mainboard Jumper
Switch**

1. SW1

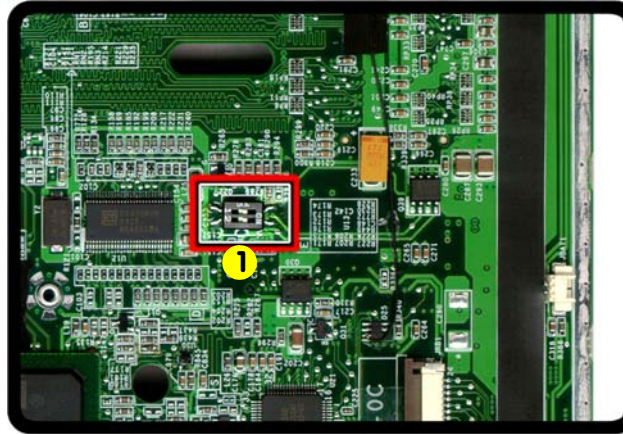

CPU Clock Setup (Switch SW1)

Table C - 1
CPU Clock Setup

SW1	1	2
FSB 400	OFF	OFF
FSB 533	ON	ON

www.s-manuals.com