

SERVICE MANUAL

M570TU

notebook

Notebook Computer

M570TU

Service Manual

Notice

The company reserves the right to revise this publication or to change its contents without notice. Information contained herein is for reference only and does not constitute a commitment on the part of the manufacturer or any subsequent vendor. They assume no responsibility or liability for any errors or inaccuracies that may appear in this publication nor are they in anyway responsible for any loss or damage resulting from the use (or misuse) of this publication.

This publication and any accompanying software may not, in whole or in part, be reproduced, translated, transmitted or reduced to any machine readable form without prior consent from the vendor, manufacturer or creators of this publication, except for copies kept by the user for backup purposes.

Brand and product names mentioned in this publication may or may not be copyrights and/or registered trademarks of their respective companies. They are mentioned for identification purposes only and are not intended as an endorsement of that product or its manufacturer.

Version 1.0
July 2008

Trademarks

Intel Core is a trademarks/registered trademarks of Intel Corporation.

 is a trademark of SRS Labs, Inc. **WOW** technology is incorporated under license from SRS Labs, Inc.

Other brand and product names are trademarks and./or registered trademarks of their respective companies.

About this Manual

This manual is intended for service personnel who have completed sufficient training to undertake the maintenance and inspection of personal computers.

It is organized to allow you to look up basic information for servicing and/or upgrading components of the *M570TU* series notebook PC.

The following information is included:

Chapter 1, Introduction, provides general information about the location of system elements and their specifications.

Chapter 2, Disassembly, provides step-by-step instructions for disassembling parts and subsystems and how to upgrade elements of the system.

Appendix A, Part Lists

Appendix B, Schematic Diagrams

Appendix C, Updating the FLASH ROM BIOS

IMPORTANT SAFETY INSTRUCTIONS

Follow basic safety precautions, including those listed below, to reduce the risk of fire, electric shock and injury to persons when using any electrical equipment:

1. Do not use this product near water, for example near a bath tub, wash bowl, kitchen sink or laundry tub, in a wet basement or near a swimming pool.
2. Avoid using a telephone (other than a cordless type) during an electrical storm. There may be a remote risk of electrical shock from lightning.
3. Do not use the telephone to report a gas leak in the vicinity of the leak.
4. Use only the power cord and batteries indicated in this manual. Do not dispose of batteries in a fire. They may explode. Check with local codes for possible special disposal instructions.
5. This product is intended to be supplied by a Listed Power Unit (DC Output 20V, 6A minimum AC/DC Adapter).

CAUTION

Always disconnect all telephone lines from the wall outlet before servicing or disassembling this equipment.

**TO REDUCE THE RISK OF FIRE, USE ONLY NO. 26 AWG OR LARGER,
TELECOMMUNICATION LINE CORD**

This Computer's Optical Device is a Laser Class 1 Product

FCC Statement (Federal Communications Commission)

You are cautioned that changes or modifications not expressly approved by the party responsible for compliance could void the user's authority to operate the equipment.

This equipment has been tested and found to comply with the limits for a Class B digital device, pursuant to Part 15 of the FCC Rules. These limits are designed to provide reasonable protection against harmful interference in a residential installation. This equipment generates, uses and can radiate radio frequency energy and, if not installed and used in accordance with the instructions, may cause harmful interference to radio communications. However, there is no guarantee that interference will not occur in a particular installation. If this equipment does cause harmful interference to radio or television reception, which can be determined by turning the equipment off and on, the user is encouraged to try to correct the interference by one or more of the following measures:

- Re orient or relocate the receiving antenna.
- Increase the separation between the equipment and receiver.
- Connect the equipment into an outlet on a circuit different from that to which the receiver is connected.
- Consult the service representative or an experienced radio/TV technician for help.

Operation is subject to the following two conditions:

1. This device may not cause interference.
And
2. This device must accept any interference, including interference that may cause undesired operation of the device.

FCC RF Radiation Exposure Statement:

1. This Transmitter must not be co-located or operating in conjunction with any other antenna or transmitter.
2. This equipment complies with FCC RF radiation exposure limits set forth for an uncontrolled environment. This equipment should be installed and operated with a minimum distance of 20 centimeters between the radiator and your body.



Warning

Use only shielded cables to connect I/O devices to this equipment. You are cautioned that changes or modifications not expressly approved by the manufacturer for compliance with the above standards could void your authority to operate the equipment.

Instructions for Care and Operation

The notebook computer is quite rugged, but it can be damaged. To prevent this, follow these suggestions:

1. **Don't drop it, or expose it to shock.** If the computer falls, the case and the components could be damaged.



2. **Keep it dry, and don't overheat it.** Keep the computer and power supply away from any kind of heating element. This is an electrical appliance. If water or any other liquid gets into it, the computer could be badly damaged.

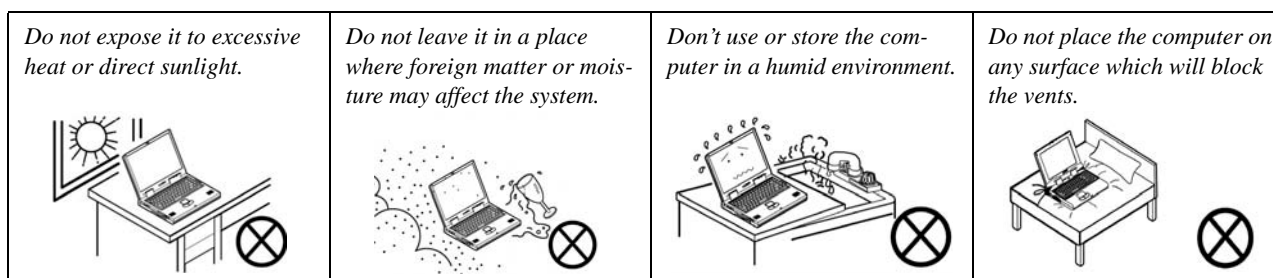

3. **Follow the proper working procedures for the computer.** Shut the computer down properly and don't forget to save your work. Remember to periodically save your data as data may be lost if the battery is depleted.

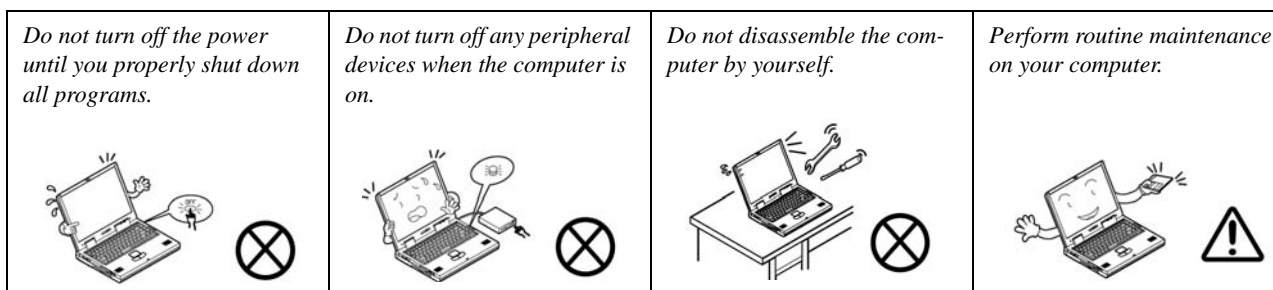

4. **Avoid interference.** Keep the computer away from high capacity transformers, electric motors, and other strong magnetic fields. These can hinder proper performance and damage your data.
5. **Take care when using peripheral devices.**

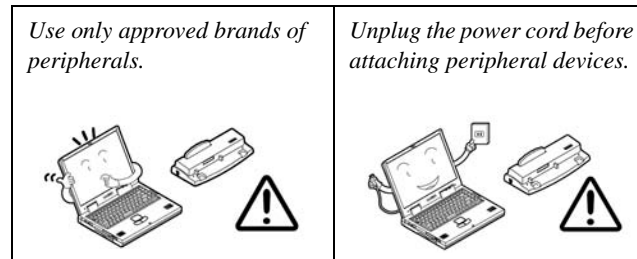

Power Safety

The computer has specific power requirements:

- Only use a power adapter approved for use with this computer.
- Your AC adapter may be designed for international travel but it still requires a steady, uninterrupted power supply. If you are unsure of your local power specifications, consult your service representative or local power company.
- The power adapter may have either a 2-prong or a 3-prong grounded plug. The third prong is an important safety feature; do not defeat its purpose. If you do not have access to a compatible outlet, have a qualified electrician install one.
- When you want to unplug the power cord, be sure to disconnect it by the plug head, not by its wire.
- Make sure the socket and any extension cord(s) you use can support the total current load of all the connected devices.
- Before cleaning the computer, make sure it is disconnected from any external power supplies (i.e. AC/DC adapter or car adapter).

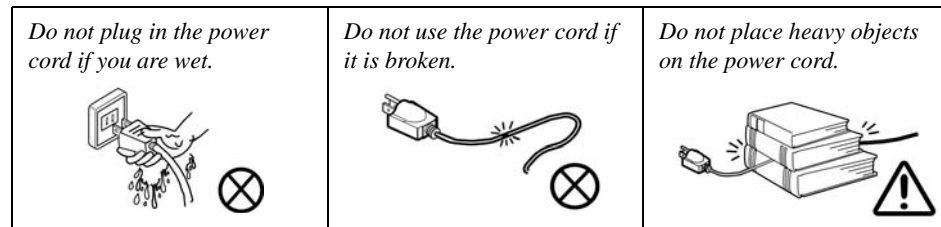

Power Safety Warning

Before you undertake any upgrade procedures, make sure that you have turned off the power, and disconnected all peripherals and cables (including telephone lines). It is advisable to also remove your battery in order to prevent accidentally turning the machine on.

Battery Precautions

- Only use batteries designed for this computer. The wrong battery type may explode, leak or damage the computer.
- Do not remove any batteries from the computer while it is powered on.
- Do not continue to use a battery that has been dropped, or that appears damaged (e.g. bent or twisted) in any way. Even if the computer continues to work with a damaged battery in place, it may cause circuit damage, which may possibly result in fire.
- Recharge the batteries using the notebook's system. Incorrect recharging may make the battery explode.
- Do not try to repair a battery pack. Refer any battery pack repair or replacement to your service representative or qualified service personnel.
- Keep children away from, and promptly dispose of a damaged battery. Always dispose of batteries carefully. Batteries may explode or leak if exposed to fire, or improperly handled or discarded.
- Keep the battery away from metal appliances.
- Affix tape to the battery contacts before disposing of the battery.
- Do not touch the battery contacts with your hands or metal objects.



Battery Disposal

The product that you have purchased contains a rechargeable battery. The battery is recyclable. At the end of its useful life, under various state and local laws, it may be illegal to dispose of this battery into the municipal waste stream. Check with your local solid waste officials for details in your area for recycling options or proper disposal.

Caution

Danger of explosion if battery is incorrectly replaced. Replace only with the same or equivalent type recommended by the manufacturer. Discard used battery according to the manufacturer's instructions.

Related Documents

You may also need to consult the following manual for additional information:

User's Manual on CD

This describes the notebook PC's features and the procedures for operating the computer and its ROM-based setup program. It also describes the installation and operation of the utility programs provided with the notebook PC.

Contents

Introduction	1-1	Removing the Inverter Board	2-22
Overview	1-1	Part Lists	A-1
System Specifications	1-2	Part List Illustration Location	A-2
External Locator - Top View with LCD Panel Open	1-5	Top with Fingerprint	A-3
External Locator - Front & Rear View	1-6	Top without Fingerprint	A-4
External Locator - Right & Left Side View	1-7	Bottom	A-5
External Locator - Bottom View	1-8	LCD	A-6
Mainboard Overview - Top (Key Parts)	1-9	DVD Combo Drive	A-7
Mainboard Overview - Bottom (Key Parts)	1-10	DVD Super-Multi Drive	A-8
Mainboard Overview - Top (Connectors)	1-11	Schematic Diagrams.....	B-1
Mainboard Overview - Bottom (Connectors)	1-12	SYSTEM BLOCK DIAGRAM	B-2
Disassembly	2-1	Penryn 1/2	B-3
Overview	2-1	Penryn 2/2	B-4
Maintenance Tools	2-2	Cantiga 1/5 Host	B-5
Connections	2-2	Cantiga 2/6 PEG	B-6
Maintenance Precautions	2-3	Cantiga 3/6 DDR	B-7
Disassembly Steps	2-4	Crestline 4/6 POWER1	B-8
Removing the Battery	2-6	Cantiga 5/6 GND	B-9
Removing the Hard Disk Drive	2-7	Cantiga 6/6 POWER2	B-10
Removing the Optical (CD/DVD) Device	2-9	DDR3 SO-DIMM 0	B-11
Removing the System Memory (RAM)	2-10	DDR3 SO-DIMM 1	B-12
Removing and Installing the Processor	2-11	LCD,CPU FAN	B-13
Removing the VGA Card	2-14	ICH9-M 1/4 SATA	B-14
Removing the Wireless LAN Module	2-15	ICH9-M 2/4 PCI,USB	B-15
Removing the TV Tuner Card	2-16	ICH9-M 3/4 CASE FAN	B-16
Removing the Turbo Memory Card	2-17	ICH9-M 4/4	B-17
Removing the Bluetooth Module	2-18	ODD, PC BEEP, USB2.0 & eSATA	B-18
Removing the Keyboard	2-19	CLOCK GENERATOR, CCD	B-19
Removing the Modem	2-20	PCI-E LAN RTL8111C	B-20

Preface

CARD READER & 1394 JMB380	B-21
NEW CARD	B-22
KBC-ITE IT8512	B-23
HDMI	B-24
LED	B-25
AZALIA CODEC ALC662	B-26
AUDIO AMP	B-27
SRS	B-28
CRT, INV, MDC, BT, PWRGD	B-29
Power Charger, DC IN	B-30
Power GPU	B-31
Power 1.5V/ 0.75V	B-32
Power 1.8VS/ 1.05VS	B-33
Power 3VS, 5VS, Power S/W	B-34
Power VDD3/ VDD5/ 3.3V/ 5V	B-35
Power VCORE for Penryn CPU	B-36
MINI CARD, CIR	B-37
MXM PCI-E TYPE-IV	B-38
Board to board CON	B-39
BUTTON BOARD	B-40
CLICK Board	B-41
Fingerprint Board	B-42
DEBUG Board	B-43

1: Introduction

Overview

This manual covers the information you need to service or upgrade the *M570TU* series notebook computer. Information about operating the computer (e.g. getting started, and the *Setup* utility) is in the *User's Manual*. Information about drivers (e.g. VGA & audio) is also found in *User's Manual*. That manual is shipped with the computer.



Operating systems (e.g. *Windows XP*, etc.) have their own manuals as do application software (e.g. word processing and database programs). If you have questions about those programs, you should consult those manuals.

The *M570TU* series notebook is designed to be upgradeable. See “*Disassembly*” on page 2 - 1 for a detailed description of the upgrade procedures for each specific component. Please note the warning and safety information indicated by the “” symbol.

The balance of this chapter reviews the computer's technical specifications and features.

System Specifications

Feature	Specification	
Processor Types	Intel® Core™2 Duo Processor (478-pin) Micro-FC-PGA Package, 25W P8400 / P8600	45nm (45 Nanometer) Process Technology 3MB On-die L2 Cache & 1066MHz FSB 2.26GHz / 2.4GHz
	Intel® Core™2 Duo Processor (478-pin) Micro-FC-PGA Package, 25W P9500	45nm (45 Nanometer) Process Technology 6MB On-die L2 Cache & 1066MHz FSB 2.53GHz
	Intel® Core™2 Duo Processor (478-pin) Micro-FC-PGA Package, 35W T9400	45nm (45 Nanometer) Process Technology 6MB On-die L2 Cache & 1066MHz FSB 2.53GHz
	Intel® Core™2 Extreme Mobile Processor (478-pin) Micro-FC-PGA Package, 44W X9100	45nm (45 Nanometer) Process Technology 6MB On-die L2 Cache & 1066MHz FSB 3.06GHz
Core Logic	Intel(R) PM45 + ICH9M Chipset	
Memory	Two 204 Pin SO-DIMM Sockets Supporting DDRIII (DDR3) 800 MHz / 1066 MHz Memory Expandable up to 4GB	
BIOS	One 2MB/ 4MB Flash ROM	Phoenix™ BIOS
Security	Security (Kensington® Type) Lock Slot Fingerprint Reader Module (Factory Option)	BIOS Password
LCD Options	17" WXGA (1440 * 900) TFT LCD (Glare Type) 17" WXGA (1440 * 900) TFT LCD (Non Glare Type)	17" WUXGA (1920 * 1200) TFT LCD (Glare Type) 17" WUXGA +(1680 * 1050) TFT LCD (Glare Type)
Storage	One Changeable 12.7mm(h) SATA Optical Device (CD/DVD) Type Drive (see " Optional " on page 1 - 4 for drive options) Easy Changeable 2.5" 9.5 mm (h) SATA HDD	
Card Reader	Embedded 7-in-1 Card Reader (MS/ MS Pro/ SD/ Mini SD/ MMC/ RS MMC/ MS Duo) Note: MS Duo/ Mini SD/ RS MMC Cards Require a PC Adapter	

Feature	Specification	
Video Card Options	NVIDIA GeForce 8800M GTX PCI-E Video Card MXM-III 512MB GDDR3 Video RAM On Board MS DirectX® 10.0 Compatible Supports HDCP	NVIDIA GeForce 9800M GTX PCI-E Video Card MXM-III 512MB GDDR3 Video RAM On Board MS DirectX® 10.0 Compatible Supports HDCP
<div style="border: 2px solid green; border-radius: 15px; padding: 10px; text-align: center;">  Video Card Options Note that card types, specifications and drivers are subject to continual updates and changes. Check with your service center for the latest details on video cards supported. </div>		
Audio	Intel High Definition Audio Compliant Interface 3D Stereo Enhanced Sound System  SRS WOW Surround Sound Technology Inside Sound-Blaster PRO™ Compatible	S/PDIF Digital Output Built-In Microphone 2 * Built-In Speakers (1.5W, 8Ω) One Sub Woofer (2W, 8Ω) 5.1 channel supported
Keyboard & Pointing Device	Full Size Winkey Keyboard with Numeric Keypad	Built-In TouchPad (Scroll Functionality Included)
ExpressCard Slot	ExpressCard/54(34) Slot	
Interface	Four USB 2.0 Ports One eSATA Port (eSATA/USB Port Combined) eSATA supported in Windows Vista only: AHCI mode supports hot swapping IDE mode does not support hot swapping One HDMI (High-Definition Multimedia Interface) Port (supports 5.1 channel) with audio output One DVI-Out Port (Supports Dual Link) One Headphone/Speaker-Out Jack One Microphone-In Jack One S/PDIF Out Jack	One Line-In Jack for Audio Input One Mini-IEEE1394 Port One RJ-11 Modem Jack One RJ-45 Giga LAN Jack One DC-In Jack One Cable (CATV) Antenna (Analog/Digital) Jack (Functions with Optional USB TV Tuner Module) One Consumer Infrared Transceiver (Functions with Optional USB TV Tuner Module)

Introduction

Feature	Specification	
Mini-Card Slots	One Mini-Card Slot for Wireless LAN Module One Mini-Card Slot for TV Tuner Module One Mini-Card Slot for Intel Turbo Memory Module	
Power Management	Supports ACPI 3.0	
Communication	Built-In 56K MDC Modem with V.90 & V.92 Compliant Built-In Gigabit Ethernet LAN Bluetooth 2.0 + EDR (Enhanced Data Rate) Module (Factory Option)	Wireless Module Options: Intel® WiFi Link 5300 (802.11 a/g/n) Wireless LAN Mini-Card Module Intel® WiFi Link 5100 (802.11 a/g/n) Wireless LAN Mini-Card Module
Power	Full Range AC/DC Adapter AC Input: 100 - 240V, 50 - 60Hz DC Output: 20V, 6.0A (120 Watts)	8 Cell Smart Lithium-Ion Battery Pack, 4400mAH
Environmental Spec	Temperature Operating: 5°C - 35°C Non-Operating: -20°C - 60°C	Relative Humidity Operating: 20% - 80% Non-Operating: 10% - 90%
Physical Dimensions & Weight	397mm (w) * 280.5mm (d) * 25.6 - 45.6mm (h)	Around 4kg (+/- 5%) with 8 Cell Battery
Optional	Optical Drive Module Options: DVD/CD-RW Combo SATA Drive Module DVD Dual (Super Multi) SATA Drive Module Blu-Ray SATA Drive Module Wireless Module Options: Intel® WiFi Link 5300 (802.11 a/g/n) Wireless LAN Mini-Card Module Intel® WiFi Link 5100 (802.11 a/g/n) Wireless LAN Mini-Card Module	TV Tuner Module with Mini-Card, USB Interface (Factory Option) 1.3M or 2.0M Pixel USB PC Camera Module (Factory Option) Fingerprint Reader Module Intel Turbo Memory (Robson) Module (2GB) (Factory Option) Bluetooth 2.0 + EDR (Enhanced Data Rate) Module

External Locator - Top View with LCD Panel Open



Figure 1
Top View

1. Optional Built-In PC Camera
2. LCD
3. Hot Key Buttons
4. Power Button
5. Keyboard
6. TouchPad and Buttons
7. Fingerprint Reader Module (**optional**)
8. LED Indicators
9. Built-In Microphone



Introduction

External Locator - Front & Rear View

Figure 2

Front & Rear Views

1. LCD Latches
2. Line-In Jack
3. Headphone-Out Jack
4. Microphone-In Jack
5. S/PDIF-Out Jack
6. LED Indicators
7. Infrared & Consumer Infrared Transceiver
8. Vent
9. HDMI-Out Port
10. DVI-Out Port
11. Combined eSATA/USB Port
12. USB 2.0 Port
13. DC-In Jack

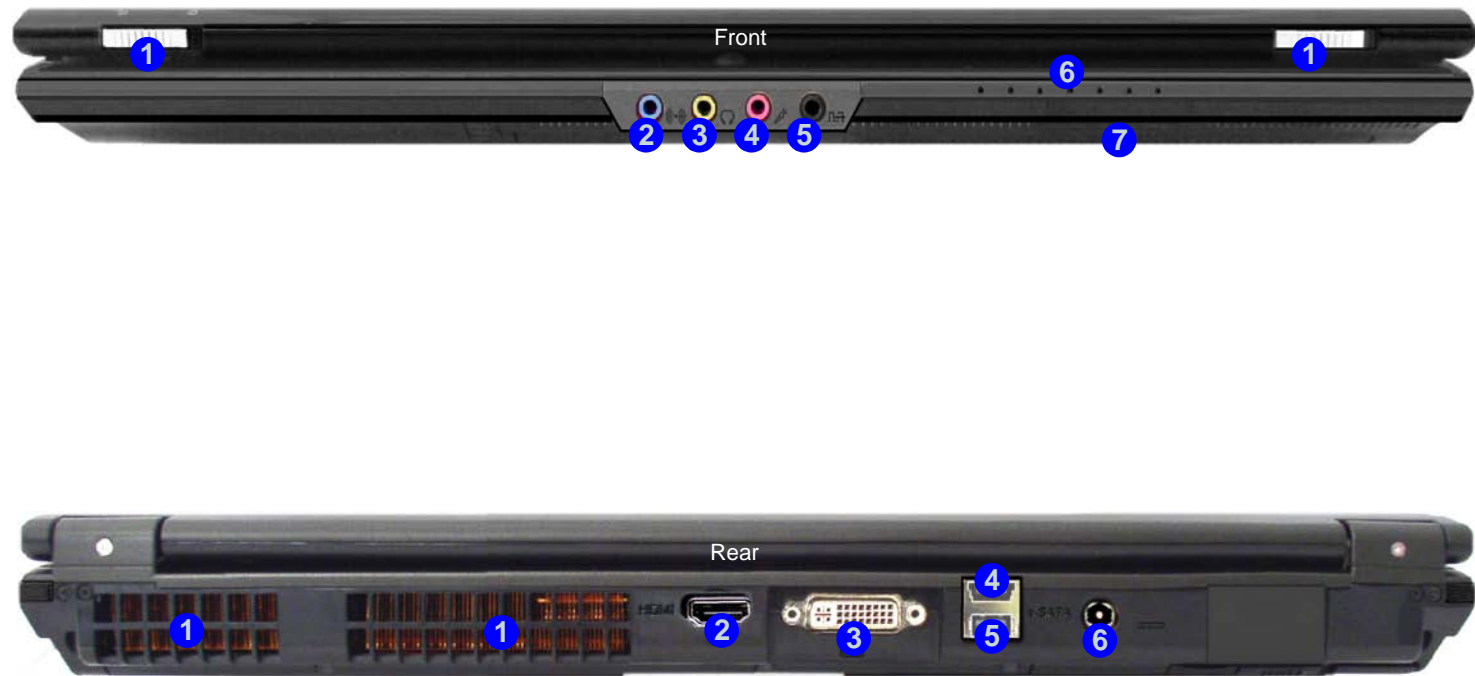

Overheating

To prevent your computer from overheating make sure nothing blocks the vent/fan intakes while the computer is in use.

External Locator - Right & Left Side View



Figure 3
Right & Left Side View

1. ExpressCard/54(34) Slot
2. 7-in-1 Card Reader
3. 2 * USB 2.0 Ports
4. Mini-IEEE 1394 Port
5. RJ-11 Phone Jack
6. RJ-45 LAN Jack
7. Cable (CATV) Antenna Jack (Enabled With TV Tuner Only)
8. Speaker
9. Security Lock Slot
10. Optical Device Drive Bay
11. Emergency Eject Hole

External Locator - Bottom View

Figure 4
Bottom View

1. Vent
2. Battery
3. Battery Release Latch
4. Optical Device Release Latches
5. Component Bay Cover
6. Consumer Infrared Transceiver
7. Sub Woofer

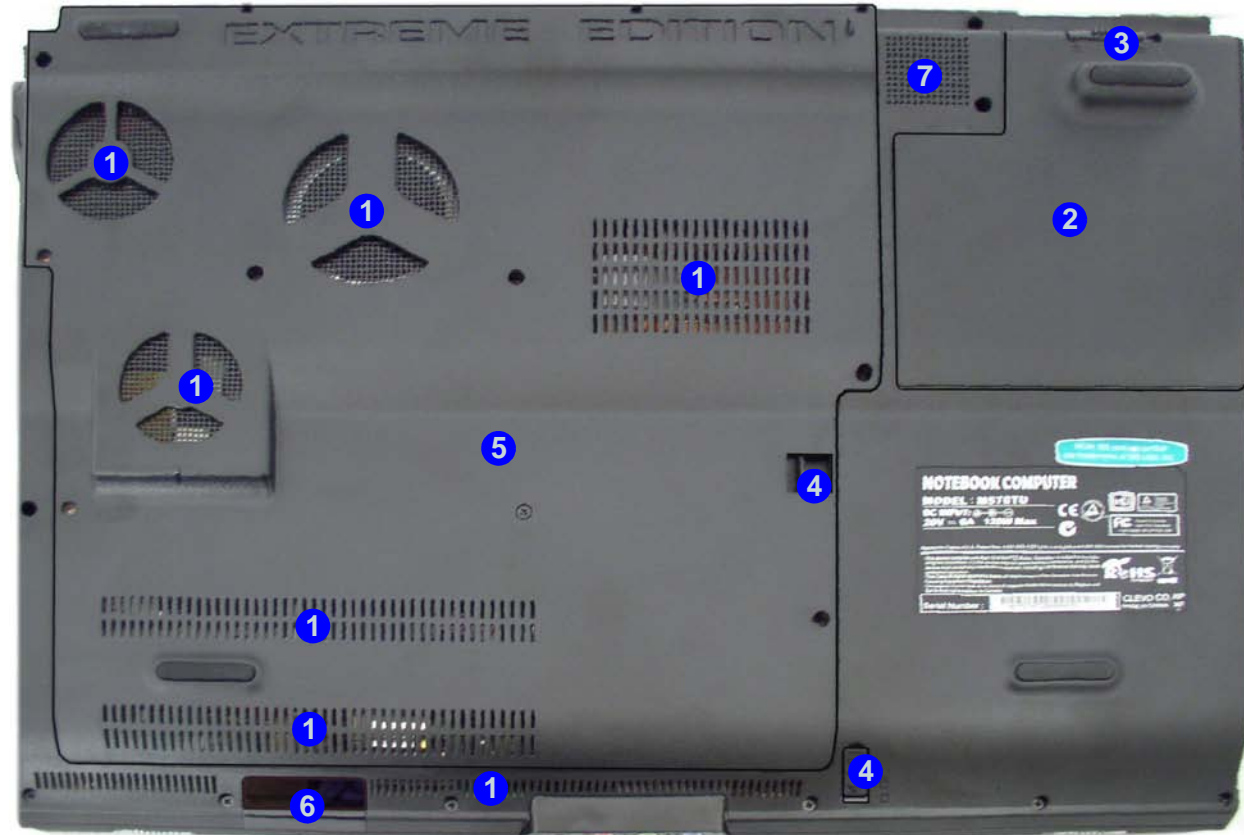

Overheating

To prevent your computer from overheating make sure nothing blocks the vent/fan intakes while the computer is in use.

Mainboard Overview - Top (Key Parts)

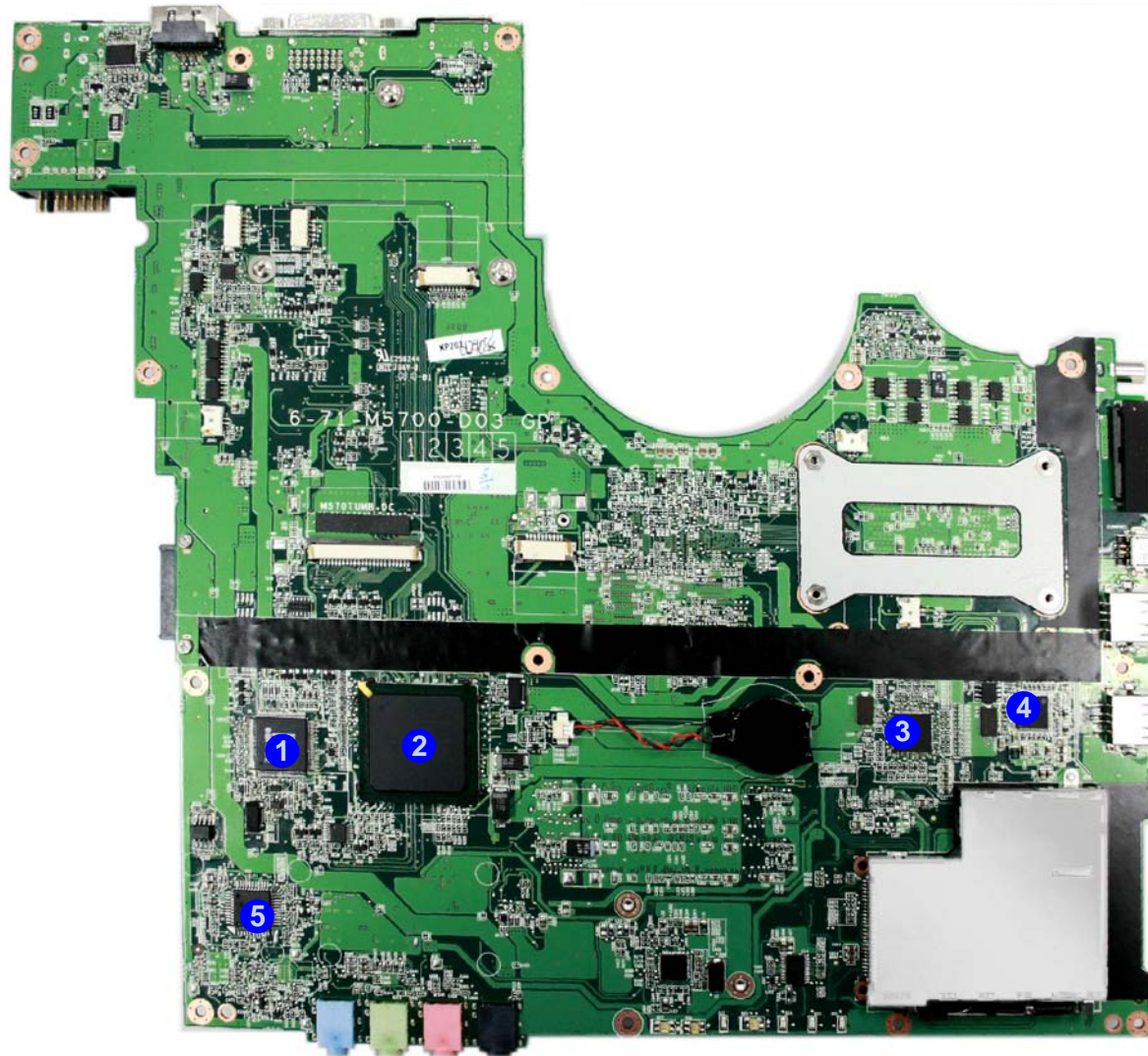

Figure 5
**Mainboard Top
Key Parts**

1. ITE IT8512E
2. South Bridge
3. Clock Generator
ICS9LPR395
4. LAN RTL8111C
5. SRS WOW
Audio Processor

Introduction

Mainboard Overview - Bottom (Key Parts)

Figure 6
**Mainboard Bottom
Key Parts**

1. CPU Socket (no CPU installed)
2. North Bridge
3. VGA Socket
4. Azalia Codec ALC 662
5. Audio Amp. APA2056
6. HDD Connector
7. Memory Slots DDR2 So-DIMM
8. Modem Socket
9. Bluetooth Cable Connector
10. MiniCard Socket (TV Tuner Card)
11. MiniCard PCIe Socket (Wireless Lan Module)
12. MiniCard Socket (Intel Turbo Memory Card)

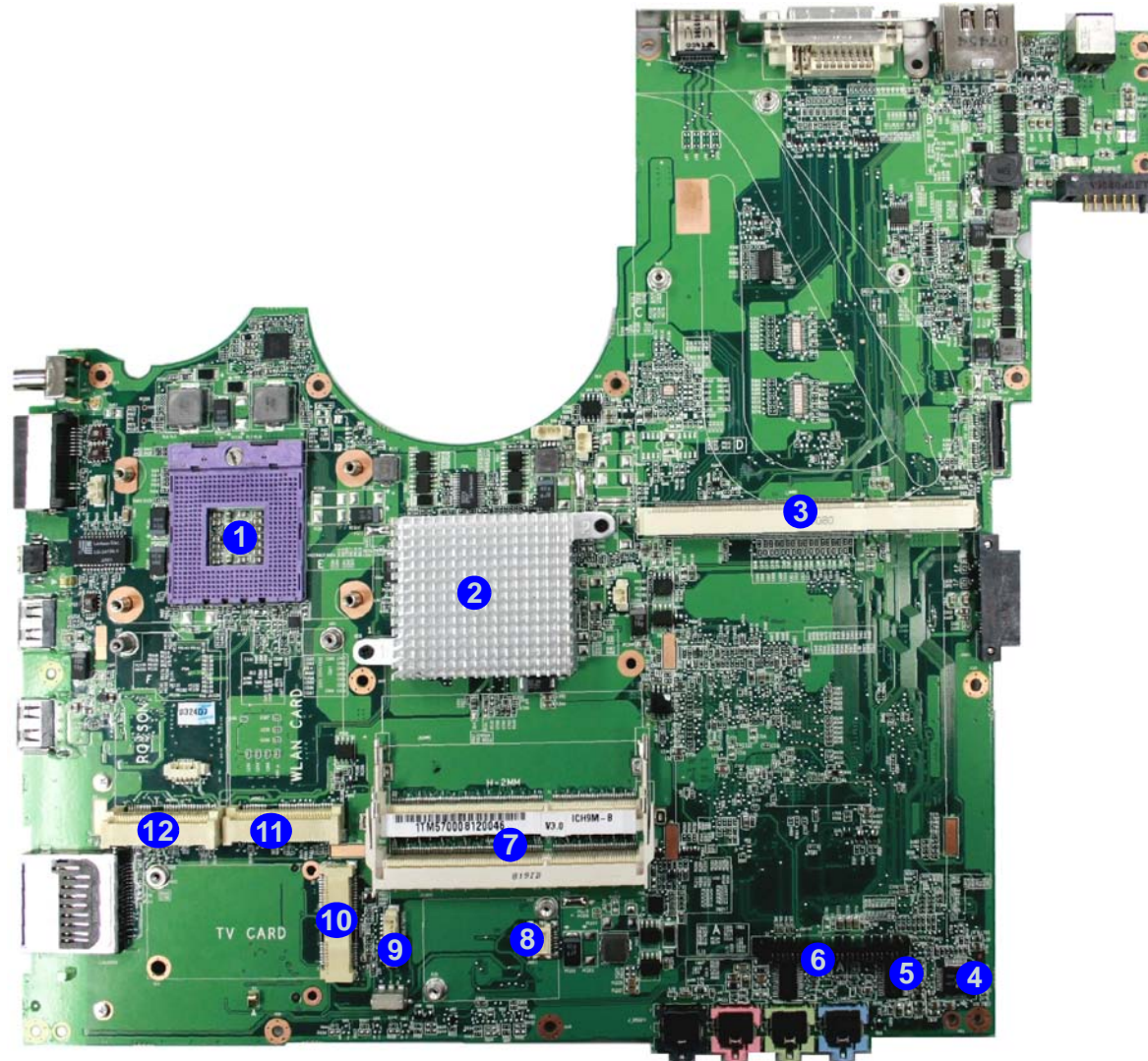

Mainboard Overview - Top (Connectors)

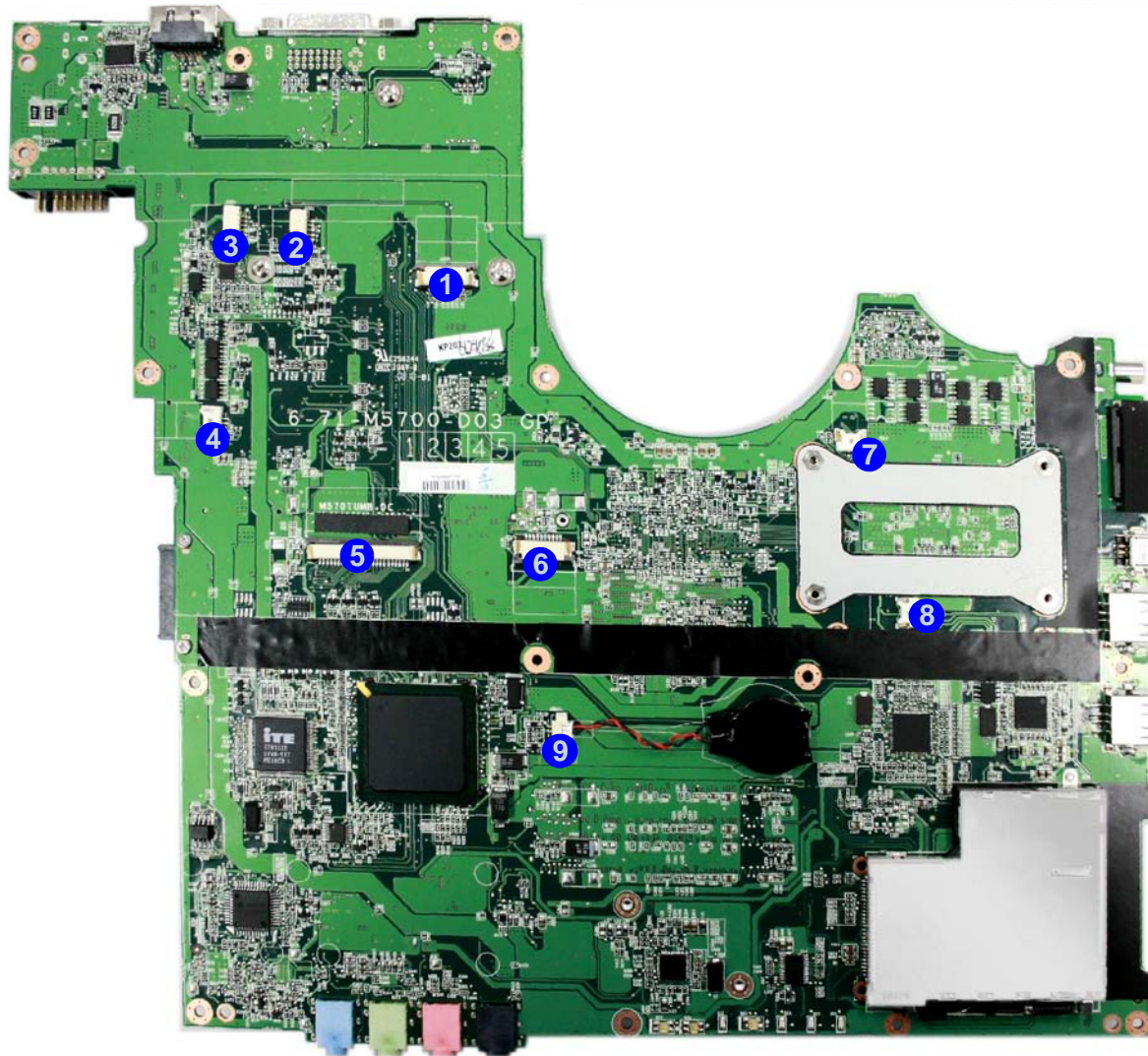

Figure 7
**Mainboard Top
Connectors**

1. LED Cable Connector
2. CCD Cable Connector
3. Inverter Board Cable Connector
4. Speaker-left Cable Connector
5. Keyboard Cable Connector
6. TouchPad Cable Connector
7. Speaker-right Cable Connector
8. Mic Cable Connector
9. RTC Battery Cable Connector

Introduction

Figure 8
**Mainboard Bottom
 Connectors**

1. HDMI Port
2. DVI-Out Port
3. Combined eSATA/
USB Port
4. DC-In Jack
5. Battery Connector
6. LCDS Cable
Connector
7. ODD Connector
8. Line-In Jack
9. Headphone Jack
10. Microphone Jack
11. S/PDIF-Out Jack
12. Speaker Connector
13. VGA Fan
Connector
14. Fan Connector
15. 7-in-1 Card Reader
Connector
16. Mini-IEEE 1394
Port
17. RJ-11 Jack
18. RJ-45 Jack
19. Cable Antenna
Jack

Mainboard Overview - Bottom (Connectors)

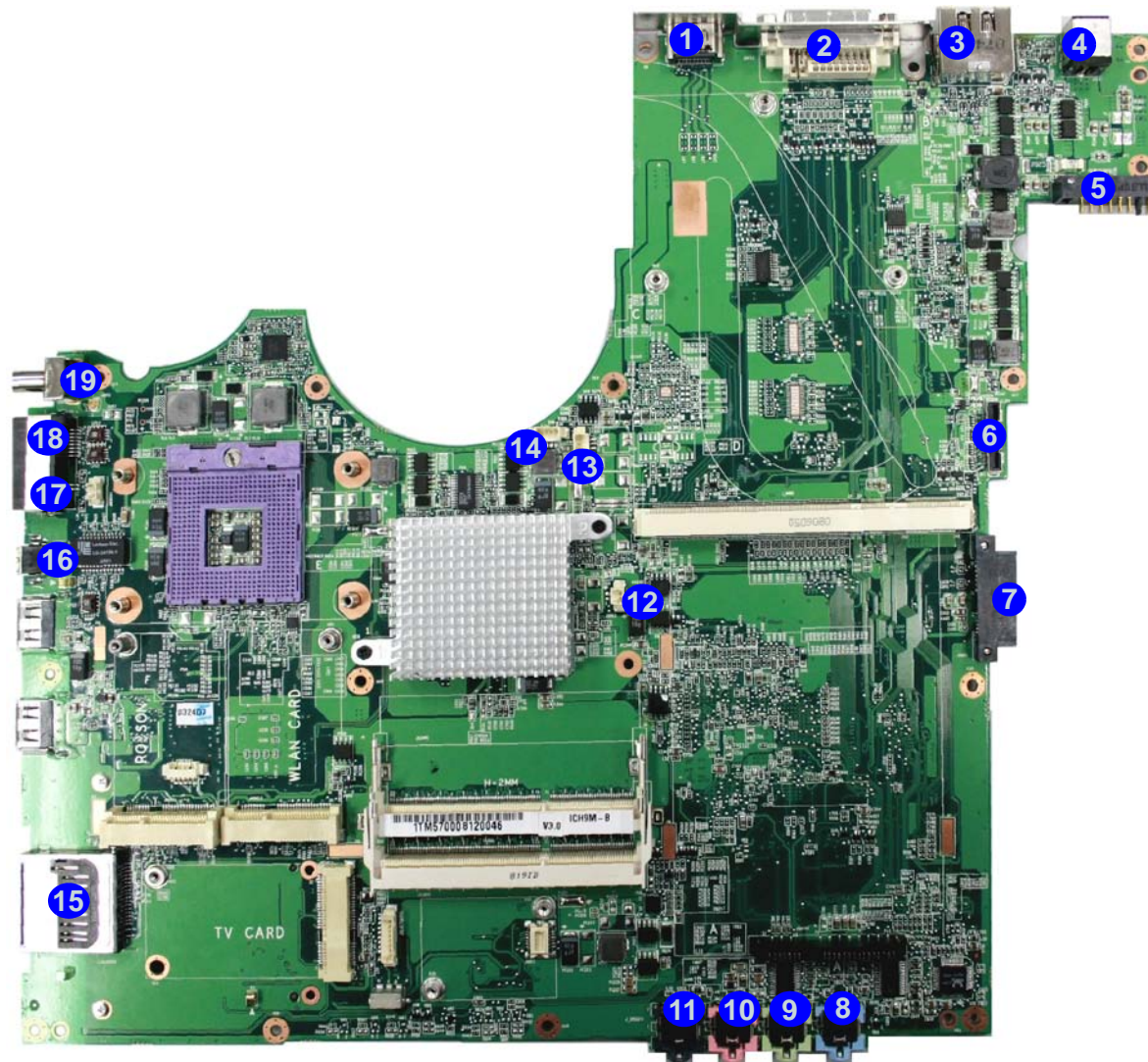

2: Disassembly



Overview

This chapter provides step-by-step instructions for disassembling the *M570TU* series notebook's parts and subsystems. When it comes to reassembly, reverse the procedures (unless otherwise indicated).

We suggest you completely review any procedure before you take the computer apart.

Procedures such as upgrading/replacing the RAM, CD device and hard disk are included in the User's Manual but are repeated here for your convenience.

To make the disassembly process easier each section may have a box in the page margin. Information contained under the figure # will give a synopsis of the sequence of procedures involved in the disassembly procedure. A box with a  lists the relevant parts you will have after the disassembly process is complete. **Note:** The parts listed will be for the disassembly procedure listed ONLY, and not any previous disassembly step(s) required. Refer to the part list for the previous disassembly procedure. The amount of screws you should be left with will be listed here also.

A box with a  will also provide any possible helpful information. A box with a  contains warnings.

An example of these types of boxes are shown in the sidebar.

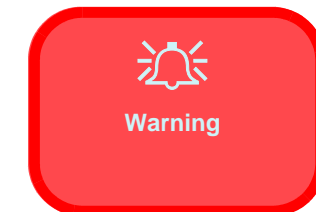
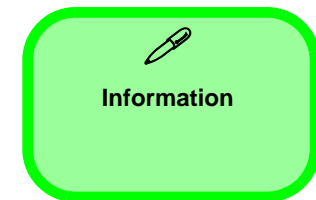

Disassembly

NOTE: All disassembly procedures assume that the system is turned **OFF**, and disconnected from any power supply (the battery is removed too).

Maintenance Tools

The following tools are recommended when working on the notebook PC:

- M3 Philips-head screwdriver
- M2.5 Philips-head screwdriver (magnetized)
- M2 Philips-head screwdriver
- Small flat-head screwdriver
- Pair of needle-nose pliers
- Anti-static wrist-strap

Connections

Connections within the computer are one of four types:

Locking collar sockets for ribbon connectors	To release these connectors, use a small flat-head screwdriver to gently pry the locking collar away from its base. When replacing the connection, make sure the connector is oriented in the same way. The pin1 side is usually not indicated.
Pressure sockets for multi-wire connectors	To release this connector type, grasp it at its head and gently rock it from side to side as you pull it out. Do not pull on the wires themselves. When replacing the connection, do not try to force it. The socket only fits one way.
Pressure sockets for ribbon connectors	To release these connectors, use a small pair of needle-nose pliers to gently lift the connector away from its socket. When replacing the connection, make sure the connector is oriented in the same way. The pin1 side is usually not indicated.
Board-to-board or multi-pin sockets	To separate the boards, gently rock them from side to side as you pull them apart. If the connection is very tight, use a small flat-head screwdriver - use just enough force to start.

Maintenance Precautions

The following precautions are a reminder. To avoid personal injury or damage to the computer while performing a removal and/or replacement job, take the following precautions:

1. **Don't drop it.** Perform your repairs and/or upgrades on a stable surface. If the computer falls, the case and other components could be damaged.
2. **Don't overheat it.** Note the proximity of any heating elements. Keep the computer out of direct sunlight.
3. **Avoid interference.** Note the proximity of any high capacity transformers, electric motors, and other strong magnetic fields. These can hinder proper performance and damage components and/or data. You should also monitor the position of magnetized tools (i.e. screwdrivers).
4. **Keep it dry.** This is an electrical appliance. If water or any other liquid gets into it, the computer could be badly damaged.
5. **Be careful with power.** Avoid accidental shocks, discharges or explosions.
 - Before removing or servicing any part from the computer, turn the computer off and detach any power supplies.
 - When you want to unplug the power cord or any cable/wire, be sure to disconnect it by the plug head. Do not pull on the wire.
6. **Peripherals** – Turn off and detach any peripherals.
7. **Beware of static discharge.** ICs, such as the CPU and main support chips, are vulnerable to static electricity. Before handling any part in the computer, discharge any static electricity inside the computer. When handling a printed circuit board, do not use gloves or other materials which allow static electricity buildup. We suggest that you use an anti-static wrist strap instead.
8. **Beware of corrosion.** As you perform your job, avoid touching any connector leads. Even the cleanest hands produce oils which can attract corrosive elements.
9. **Keep your work environment clean.** Tobacco smoke, dust or other air-borne particulate matter is often attracted to charged surfaces, reducing performance.
10. **Keep track of the components.** When removing or replacing any part, be careful not to leave small parts, such as screws, loose inside the computer.

Cleaning

Do not apply cleaner directly to the computer, use a soft clean cloth.

Do not use volatile (petroleum distillates) or abrasive cleaners on any part of the computer.



Power Safety Warning

Before you undertake any upgrade procedures, make sure that you have turned off the power, and disconnected all peripherals and cables (including telephone lines). It is advisable to also remove your battery in order to prevent accidentally turning the machine on.

Disassembly Steps

The following table lists the disassembly steps, and on which page to find the related information. **PLEASE PERFORM THE DISASSEMBLY STEPS IN THE ORDER INDICATED.**

To remove the Battery:

1. Remove the battery [page 2 - 6](#)

To remove the HDD:

1. Remove the battery [page 2 - 6](#)
2. Remove the HDD [page 2 - 7](#)

To remove the Optical Device:

1. Remove the battery [page 2 - 6](#)
2. Remove the Optical device [page 2 - 9](#)

To remove the System Memory:

1. Remove the battery [page 2 - 6](#)
2. Remove the system memory [page 2 - 10](#)

To remove the Processor:

1. Remove the battery [page 2 - 6](#)
2. Remove the processor [page 2 - 11](#)
3. Install the processor [page 2 - 13](#)

To remove the VGA Card:

1. Remove the battery [page 2 - 6](#)
2. Remove the VGA Card [page 2 - 14](#)

To remove the Wireless LAN Module:

1. Remove the battery [page 2 - 6](#)
2. Remove the WLAN module [page 2 - 15](#)

To remove the TV Tuner Card:

1. Remove the battery [page 2 - 6](#)
2. Remove the TV Tuner Card [page 2 - 16](#)

To remove the Turbo Memory Card:

1. Remove the battery [page 2 - 6](#)
2. Remove the Turbo Memory Card [page 2 - 17](#)

To remove the Bluetooth Module:

1. Remove the battery [page 2 - 6](#)
2. Remove the Bluetooth Module [page 2 - 18](#)

To remove the Keyboard:

1. Remove the battery [page 2 - 6](#)
2. Remove the keyboard [page 2 - 19](#)

To remove the Modem:

1. Remove the battery [page 2 - 6](#)
2. Remove the HDD [page 2 - 7](#)
3. Remove the Optical device [page 2 - 9](#)
4. Remove the system memory [page 2 - 10](#)
5. Remove the processor [page 2 - 11](#)

6. Remove the VGA Card *page 2 - 13*
7. Remove the WLAN module *page 2 - 15*
8. Remove the TV Tuner Card *page 2 - 16*
9. Remove the Bluetooth Module *page 2 - 18*
10. Remove the keyboard *page 2 - 19*
11. Remove the Modem *page 2 - 20*

To remove the Inverter Board:

1. Remove the battery *page 2 - 6*
2. Remove the inverter board *page 2 - 22*

Disassembly

Figure 1
Battery Removal

- Slide latch at point 1 towards the unlock symbol and hold it in place.
- Lift the battery out.

Removing the Battery

- Turn the computer off, and turn it over.
- Slide latch **1** towards the unlock symbol and hold it in place, and lift the battery **2** up and out of the battery bay.

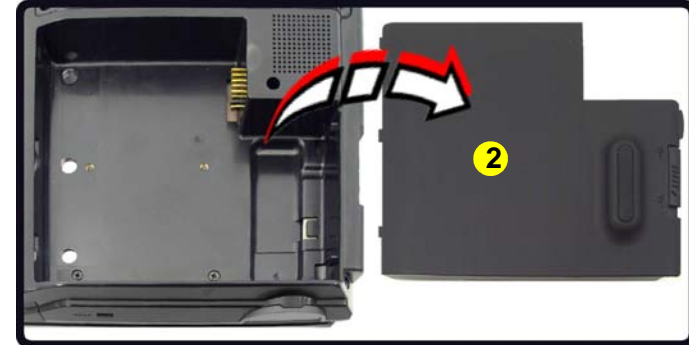
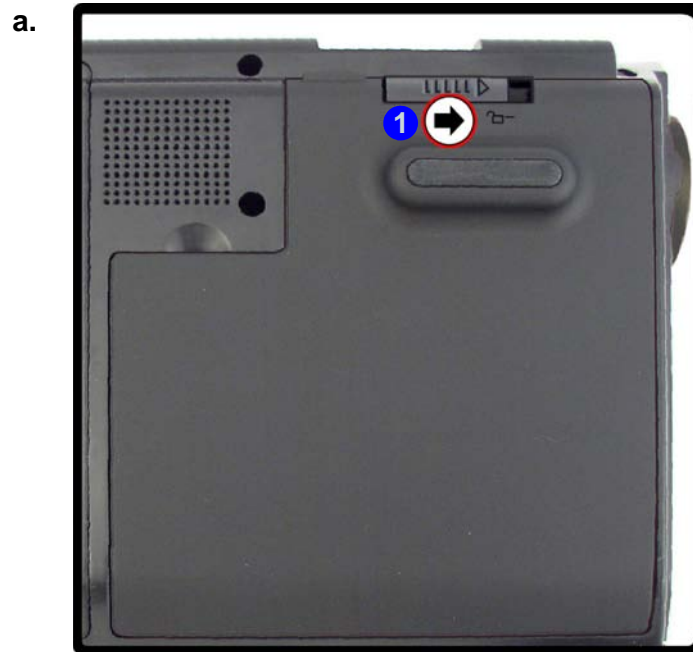

2. Battery

Removing the Hard Disk Drive

The hard disk drive is mounted in a removable case and can be taken out to accommodate other 2.5" serial (SATA) hard disk drives with a height of 9.5mm (h). Follow your operating system's installation instructions, and install all necessary drivers and utilities (as outlined in **Chapter 4 of the User's Manual**) when setting up a new hard disk.

Hard Disk Upgrade Process

1. Turn **off** the computer, and turn it over and remove the battery ([page 2 - 6](#)).
2. Locate the component bay cover and remove screws **1** - **11**.
3. Remove the bay cover **12**.
4. The hard disk assembly will be visible at point **13** on the mainboard.

Figure 2
HDD Assembly Removal

- a. Remove the screws.
- b. Remove the cover and locate the HDD.

a.

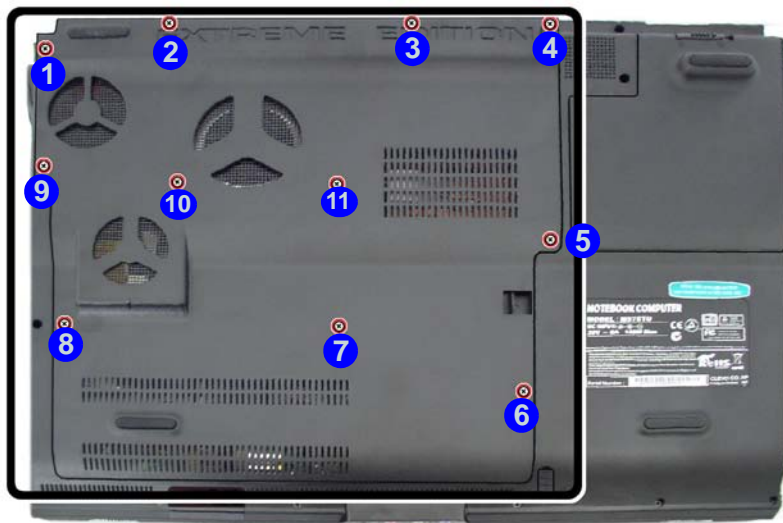

b.

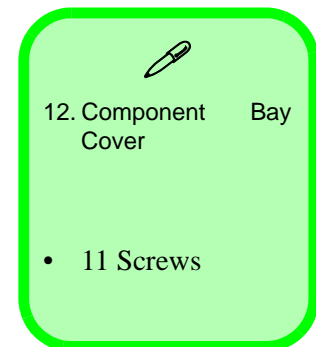
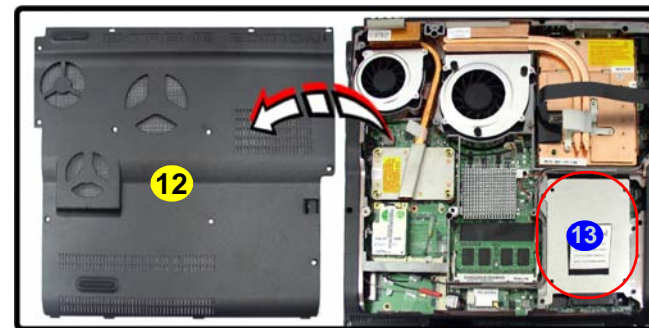

Disassembly

Figure 3
**HDD Assembly
 Removal (cont'd.)**

- c. Remove screws and slide the HDD module in the direction of the arrow
- d. Remove the HDD module.
- e. Remove the screws and lift the shielding plate up from the HDD.

5. Remove screws 14 - 17 from the hard disk cover.
6. Slide the hard disk assembly in the direction of the arrow 18.
7. Carefully remove the hard disk assembly in the direction of the arrow 19 (Figure 3d).
8. Remove screws 20 - 23 and lift the HDD shielding plate 24 up from the hard disk 25.
9. Reverse the process to install a new hard disk(s).

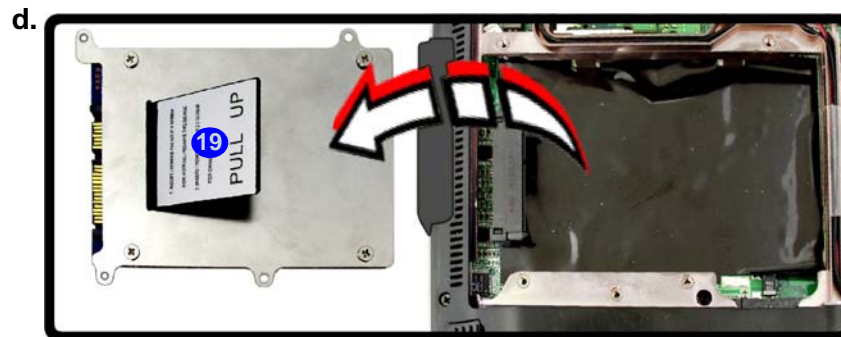
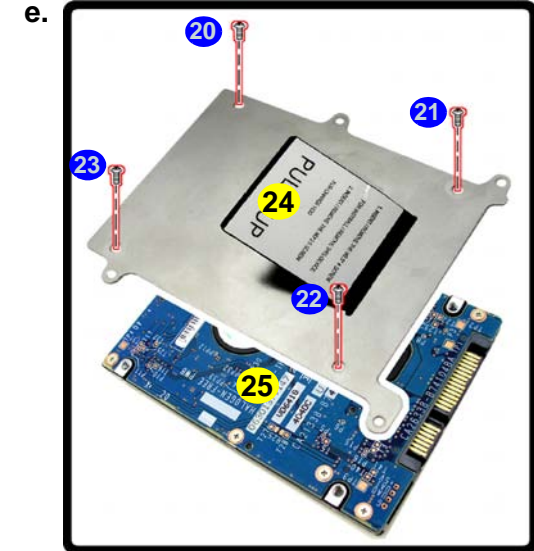
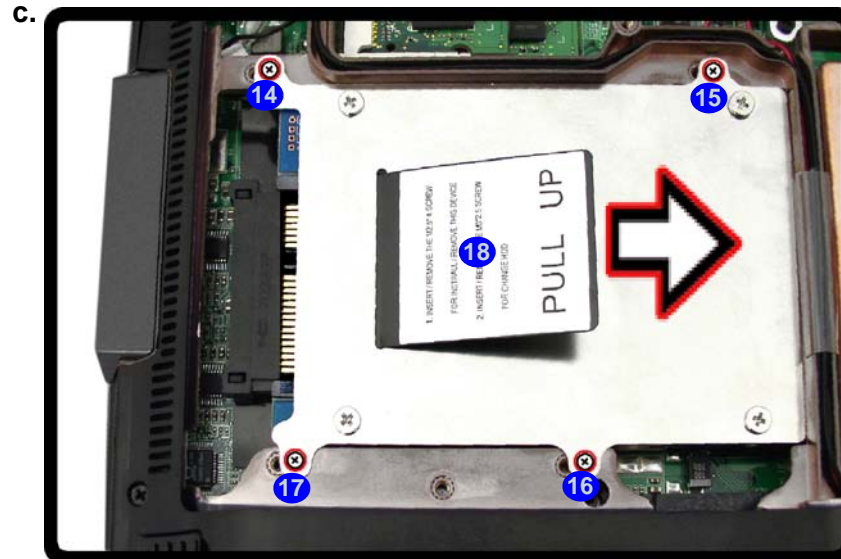

24. HDD Shielding Plate
 25. HDD

- 8 Screws

Removing the Optical (CD/DVD) Device

1. Turn **off** the computer, turn it over and remove the battery ([page 2 - 6](#)).
2. Slide latch **1** towards the unlock symbol and hold it in place.
3. Slide latch **2** (while still holding latch **1** in place) in the direction indicated by the arrow in order to push the optical device **3** out of the computer.
4. Restart the computer to allow it to automatically detect the new device.

Figure 4
Optical Device Removal

- a. Slide latch at point 1 towards the unlock symbol and hold it in place. Then slide the optical device out of the computer at point 2.

a.

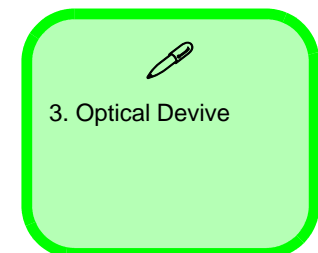
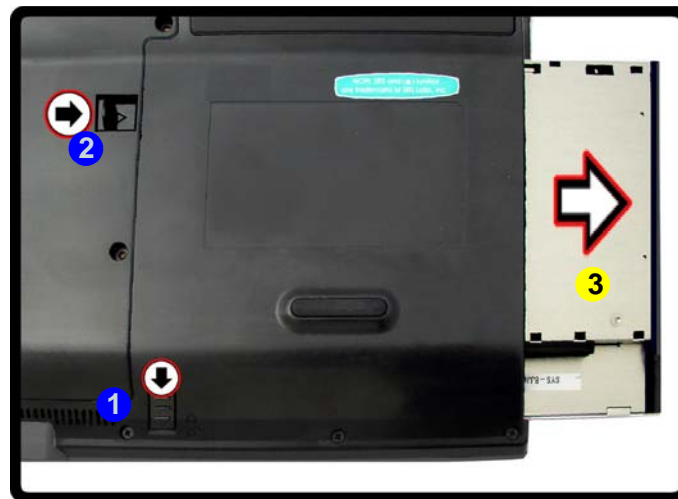

Figure 5
RAM Module Removal

- Locate the memory socket.
- Pull the release latch(es).
- Remove the module(s).



Contact Warning

Be careful not to touch the metal pins on the module's connecting edge. Even the cleanest hands have oils which can attract particles, and degrade the module's performance.



4. RAM Module

Removing the System Memory (RAM)

The computer has two memory sockets for 204 pin Small Outline Dual In-line Memory Modules (SO-DIMM) supporting DDRII (DDR3) Up to 800/1066 MHz. The main memory can be expanded up to 4GB. The SO-DIMM modules supported are 256MB, 512MB, 1024MB and 2048MB **DDRIII** Modules. The total memory size is automatically detected by the POST routine once you turn on your computer.

Memory Upgrade Process

- Turn **off** the computer, turn it over and remove the battery ([page 2 - 6](#)) and the component bay cover ([page 2 - 7](#)).
- The RAM module(s) will be visible at point **1** on the mainboard.
- Gently pull the two release latches (**2** & **3**) on the sides of the memory socket in the direction indicated by the arrows ([Figure 5b](#)).

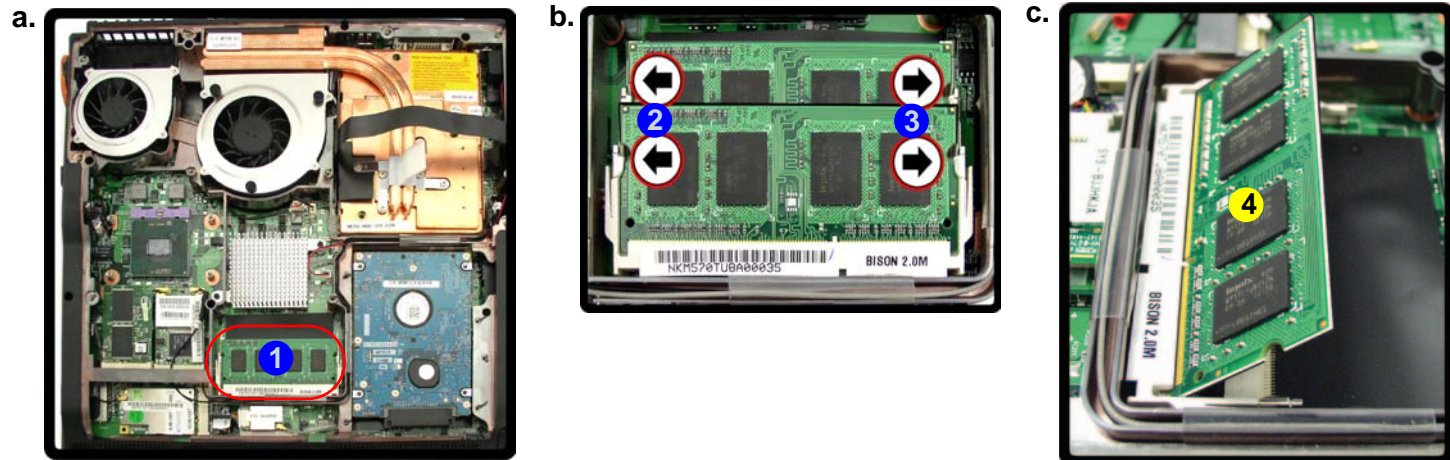

- The RAM module(s) **4** will pop-up ([Figure 5c](#)), and you can then remove it.
- Pull the latches to release the second module if necessary.
- Insert a new module holding it at about a 30° angle and fit the connectors firmly into the memory slot.
- The module will only fit one way as defined by its pin alignment. Make sure the module is seated as far into the slot as it will go. **DO NOT FORCE IT**; it should fit without much pressure.
- Press the module in and down towards the mainboard until the slot levers click into place to secure the module.
- Replace the bay cover and the screws (see [page 2 - 7](#)).
- Restart the computer to allow the BIOS to register the new memory configuration as it starts up.

Removing and Installing the Processor

Processor Removal Procedure

1. Turn **off** the computer, turn it over and remove the battery ([page 2 - 6](#)) and the component bay cover ([page 2 - 7](#)).
2. The CPU heat sink will be visible at point **A** on the mainboard.
3. Loosen screws **4** , **3** , **2** , **1** ([Figure 6b](#)) the reverse order as indicated on the label.
4. Carefully lift the heat sink **B** ([Figure 6c](#)) up and off the computer.

Figure 6
Processor Removal

- a. Locate the heat sink.
- b. Loosen the screws in the reverse order indicated.
- c. Remove the heat sink.

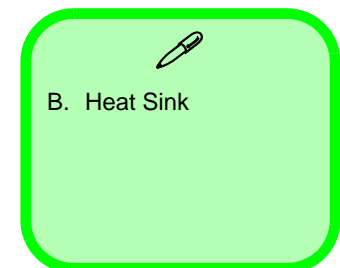
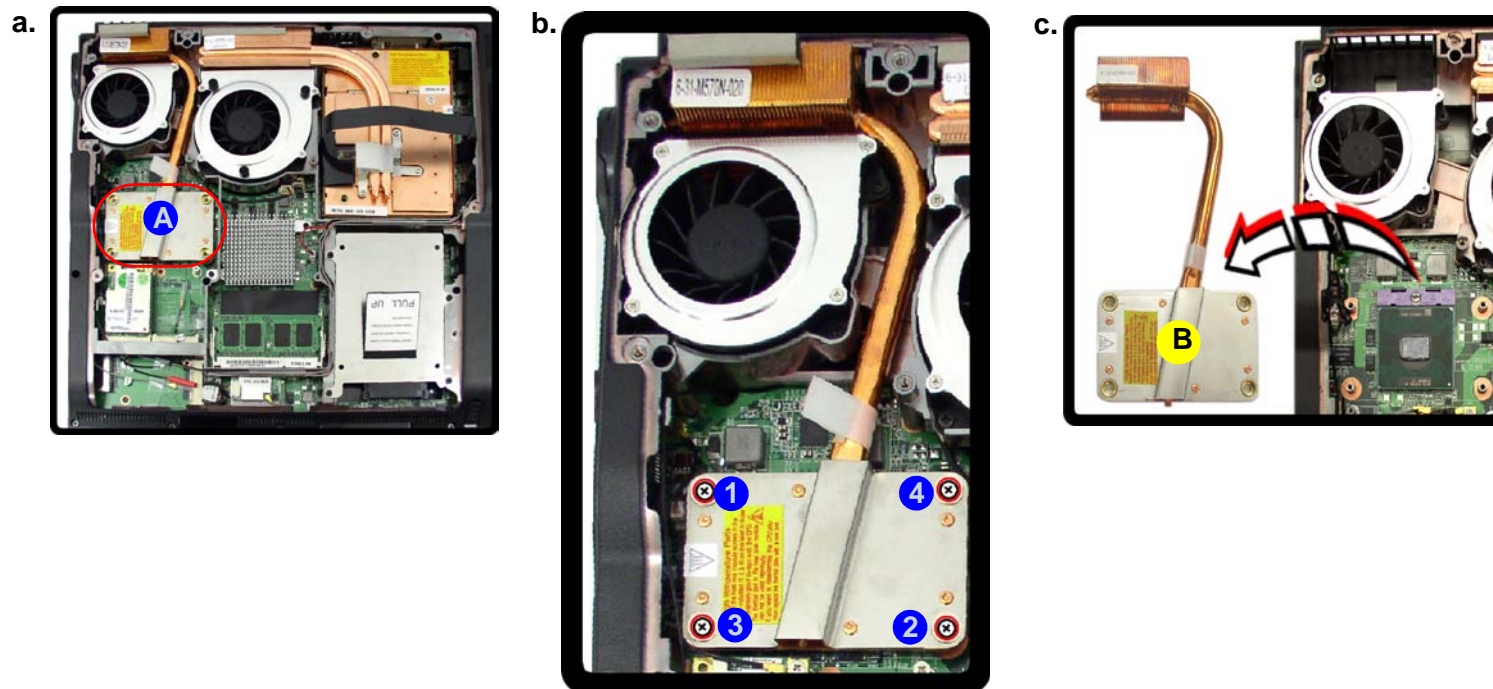

Disassembly

Figure 7 Processor Removal (cont'd)

- d. Turn the release latch to unlock the CPU.
e. Lift the CPU out of the socket.

5. Turn the release latch **C** towards the unlock symbol  to release the CPU.
6. Carefully (it may be hot) lift the CPU **D** up and out of the socket (**Figure 7e**).

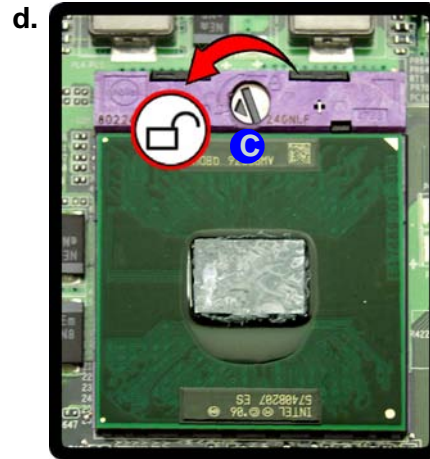

Unlock

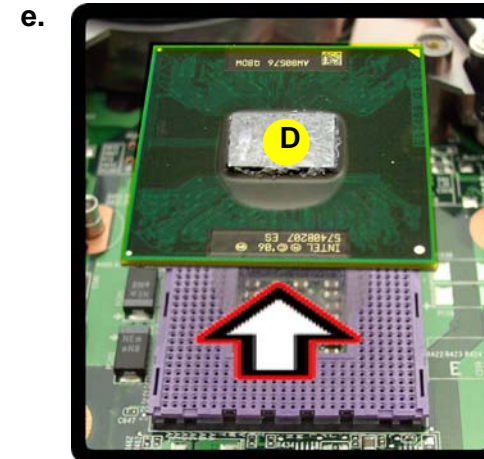

Caution

The heat sink, and CPU area in general, contains parts which are subject to high temperatures. Allow the area time to cool before removing these parts.



D. CPU

Processor Installation Procedure



1. Insert the CPU **A**, pay careful attention to the pin alignment, it will fit only one way (DO NOT FORCE IT!), and turn the release latch **B** towards the lock symbol  (*Figure 8b*).
2. **Remove the sticker C** (*Figure 8c*) from the heat sink.
3. Insert the heat sink **D** as indicated in *Figure 8c*.
4. Tighten screws **1** - **4** in the order indicated on the label.
5. Replace the component bay cover and tighten the screws (*page 2 - 7*).

Figure 8
Processor Installation

- a. Insert the CPU.
- b. Turn the release latch towards the lock symbol.
- c. Remove the sticker from the heat sink and insert the heat sink.
- d. Tighten the screws.



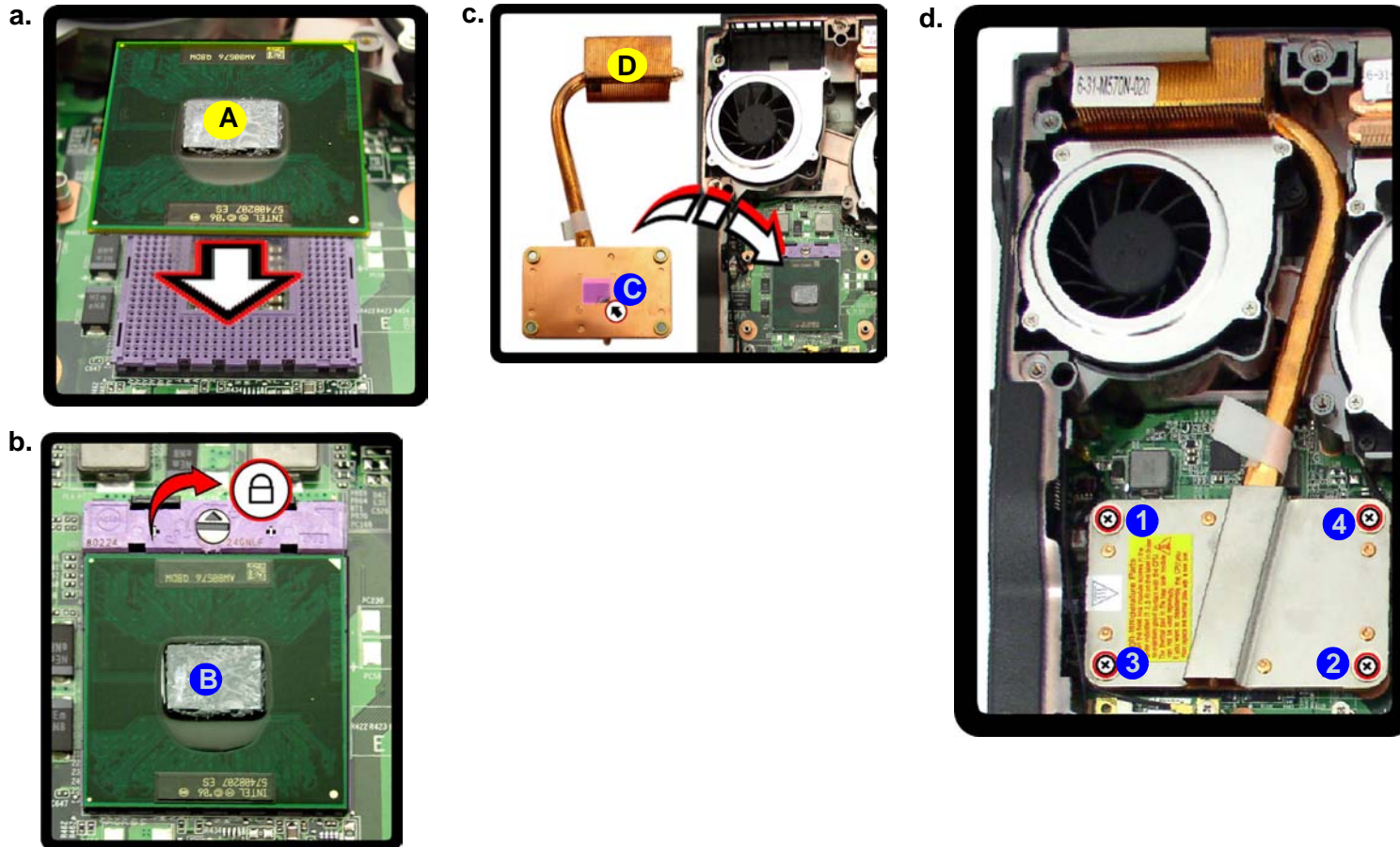

A. CPU
D. Heat Sink

Disassembly

Figure 9

VGA Card Removal

- Locate the VGA card.
- Remove the screws
- Remove the VGA heatsink.
- Remove the screws.
- Pull the plastic holder in the direction of the arrow.
- Lift the VGA card out of the socket.

Removing the VGA Card

- Turn **off** the computer, turn it over and remove the battery ([page 2 - 6](#)), and the component bay cover ([page 2 - 7](#)).
- The VGA card(s) will be visible at point **A** on the mainboard.
- Remove screws **4**, **3**, **2**, **1** ([Figure 6b](#)) the reverse order as indicated on the label.
- Carefully lift the VGA heatsink **B** up and off the VGA card.
- Remove screws **7**, **6**, **5** ([Figure 6c](#)) the reverse order as indicated on the label.
- Carefully grip the plastic holder **C** and lift the video card **D** up and off the socket **E**.
- Reverse the process to install the new VGA Card.

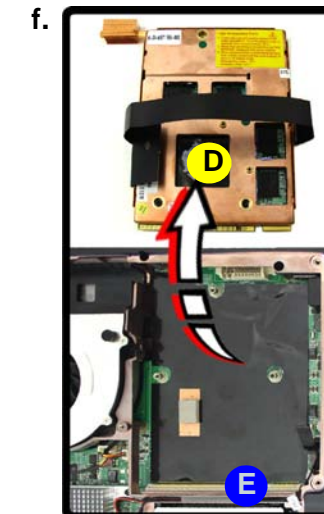
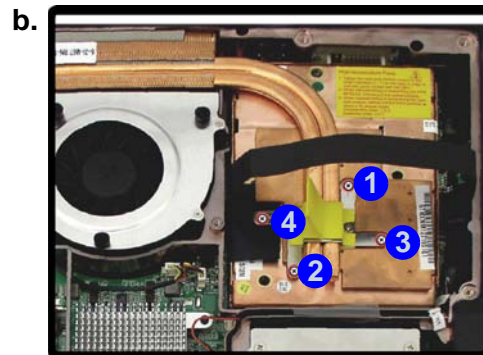
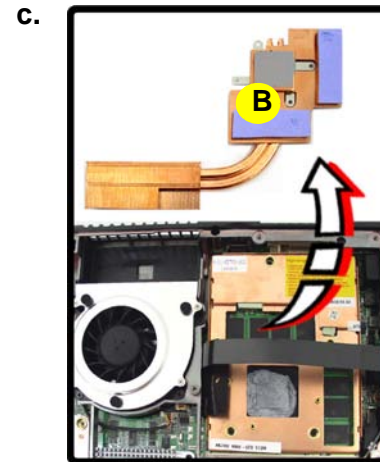
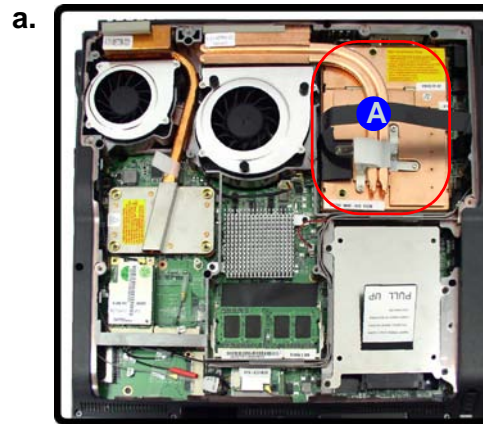

B. VGA Heatsink
D. VGA Card

- 7 Screws

Removing the Wireless LAN Module

1. Turn **off** the computer, turn it over and remove the battery ([page 2 - 6](#)) and the component bay cover ([page 2 - 7](#)).
2. The Wireless LAN module will be visible at point **1** on the mainboard.
3. Carefully disconnect cables **2** - **3**, and then remove screw **4**.
4. The Wireless LAN module **5** ([Figure 10c](#)) will pop-up, and you can remove it.

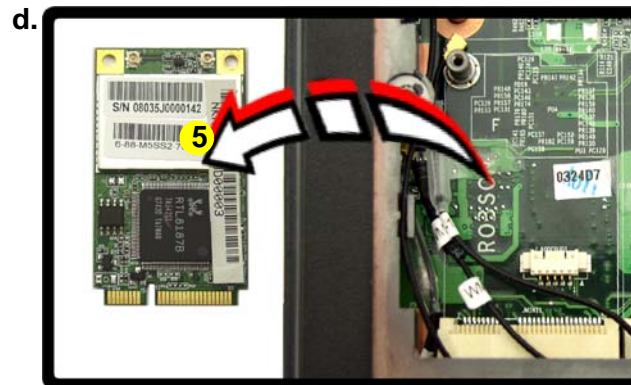
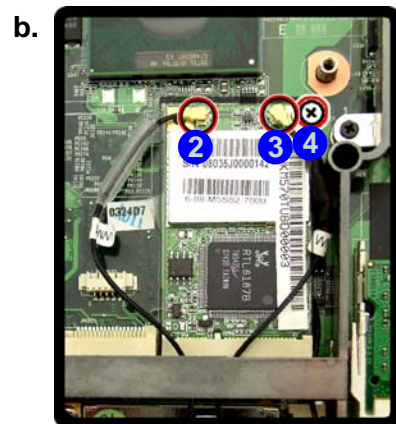



Figure 10
**Wireless LAN
Module Removal**

- a. Locate the WLAN.
- b. Disconnect the cables and remove the screw.
- c. The WLAN module will pop up.
- d. Remove the WLAN module.

Note: Make sure you reconnect the antenna cable to “1” + “2” socket ([Figure 10b](#)).



5. Wireless LAN Module

- 1 Screw

Disassembly

Figure 11
**TV Tuner Card
 Removal**

- Locate the TV Tuner card.
- Disconnect the cable and remove the screw.
- The TV Tuner card will pop up.
- Remove the TV Tuner card.

Removing the TV Tuner Card

- Turn **off** the computer, turn it over and remove the battery ([page 2 - 6](#)) and the component bay cover ([page 2 - 7](#)).
- The TV Tuner card will be visible at point **1** on the mainboard.
- Carefully disconnect cables **2**, and then remove screw **3**.
- The TV Tuner card **4** ([Figure 11c](#)) will pop-up, and you can remove it.

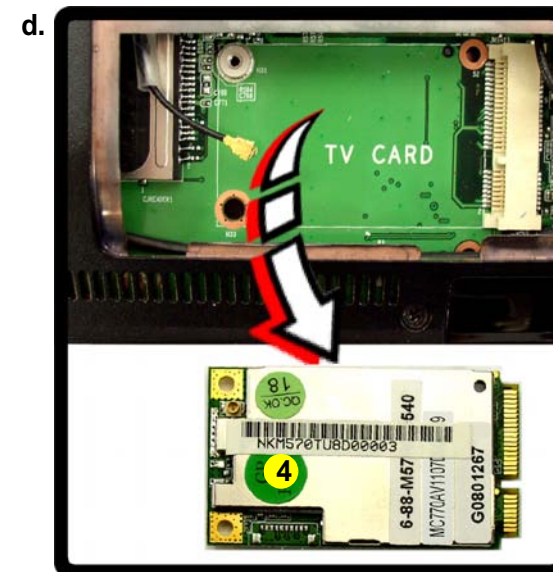
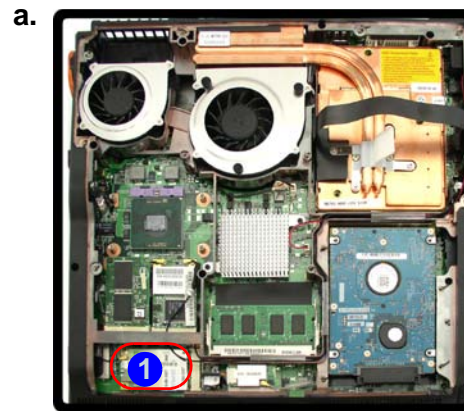

4. TV Tuner Card

- 1 Screw

Removing the Turbo Memory Card

1. Turn **off** the computer, turn it over and remove the battery ([page 2 - 6](#)) and the component bay cover ([page 2 - 7](#)).
2. The turbo memory card will be visible at point **1** on the mainboard.
3. Remove screw **2** from the module.
4. The turbo memory card **3** ([Figure 12c](#)) will pop-up, and you can remove it.

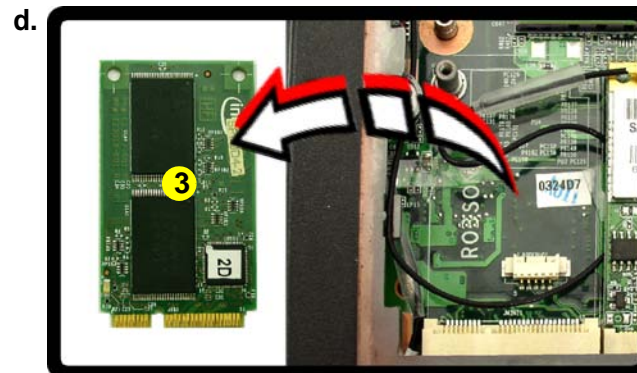
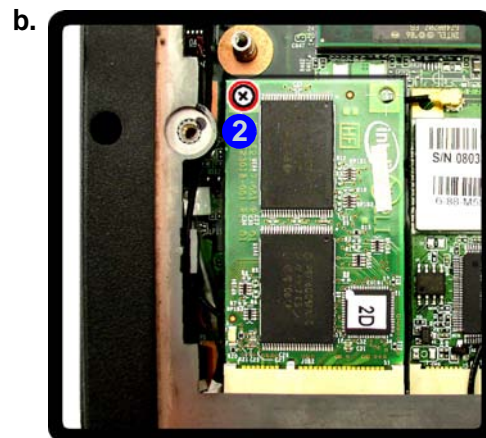
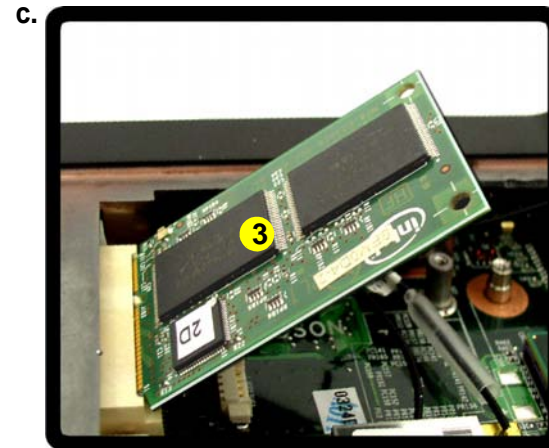
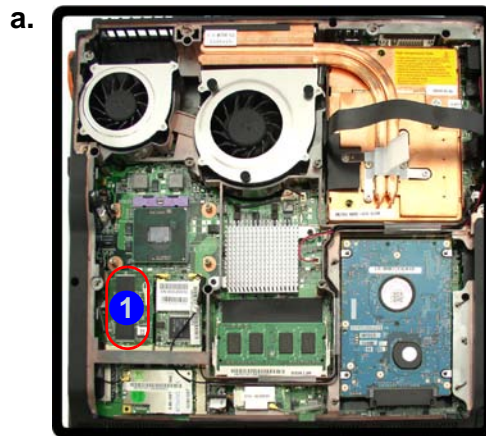
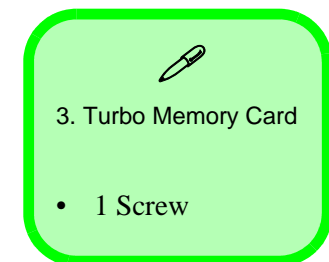

Figure 12
Turbo Memory Card Removal

- a. Locate the turbo memory card.
- b. Remove the screw.
- c. The turbo memory card will pop up.
- d. Remove the turbo memory card.



Disassembly

Figure 13
Bluetooth Module Removal

- Locate the Bluetooth module.
- Disconnect the cable and the connector from the bluetooth module.
- Lift the Bluetooth module out.

Removing the Bluetooth Module

- Turn **off** the computer, turn it over, and remove the battery ([page 2 - 6](#)) and the component bay cover ([page 2 - 7](#)).
- The Bluetooth module will be visible at point **1** on the mainboard.
- Disconnect the cable **2** and carefully separate the Bluetooth Module from the connector **3** ([Figure 13b](#)).
- Lift the Bluetooth Module **4** ([Figure 13c](#)) up and off the computer.

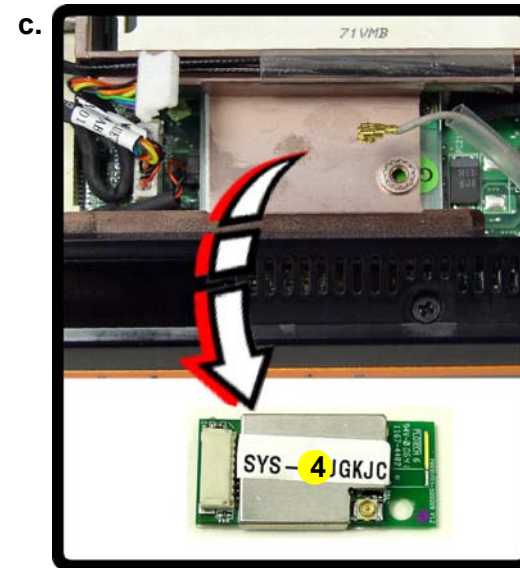
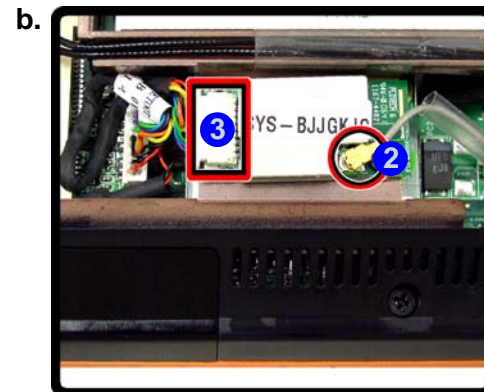
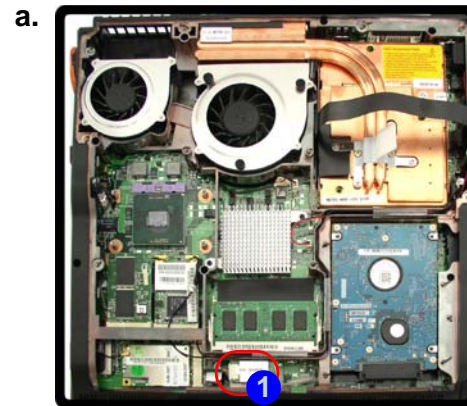

4. Bluetooth Module

Removing the Keyboard

1. Turn **off** the computer, and remove the battery ([page 2 - 6](#)).
2. Press the **five** keyboard latches at the top of the keyboard to elevate the keyboard from its normal position (you may need to use a small screwdriver to do this).
3. Carefully lift the keyboard up, being careful not to bend the keyboard ribbon cable **6** ([Figure 14b](#)).
4. Disconnect the keyboard ribbon cable **6** from the locking collar socket **7**.
5. Carefully lift up the keyboard **8** ([Figure 14c](#)) off the computer.

Figure 14
Keyboard Removal

- a. Press the five latches to release the keyboard.
- b. Lift the keyboard up and disconnect the cable from the locking collar.
- c. Remove the keyboard.

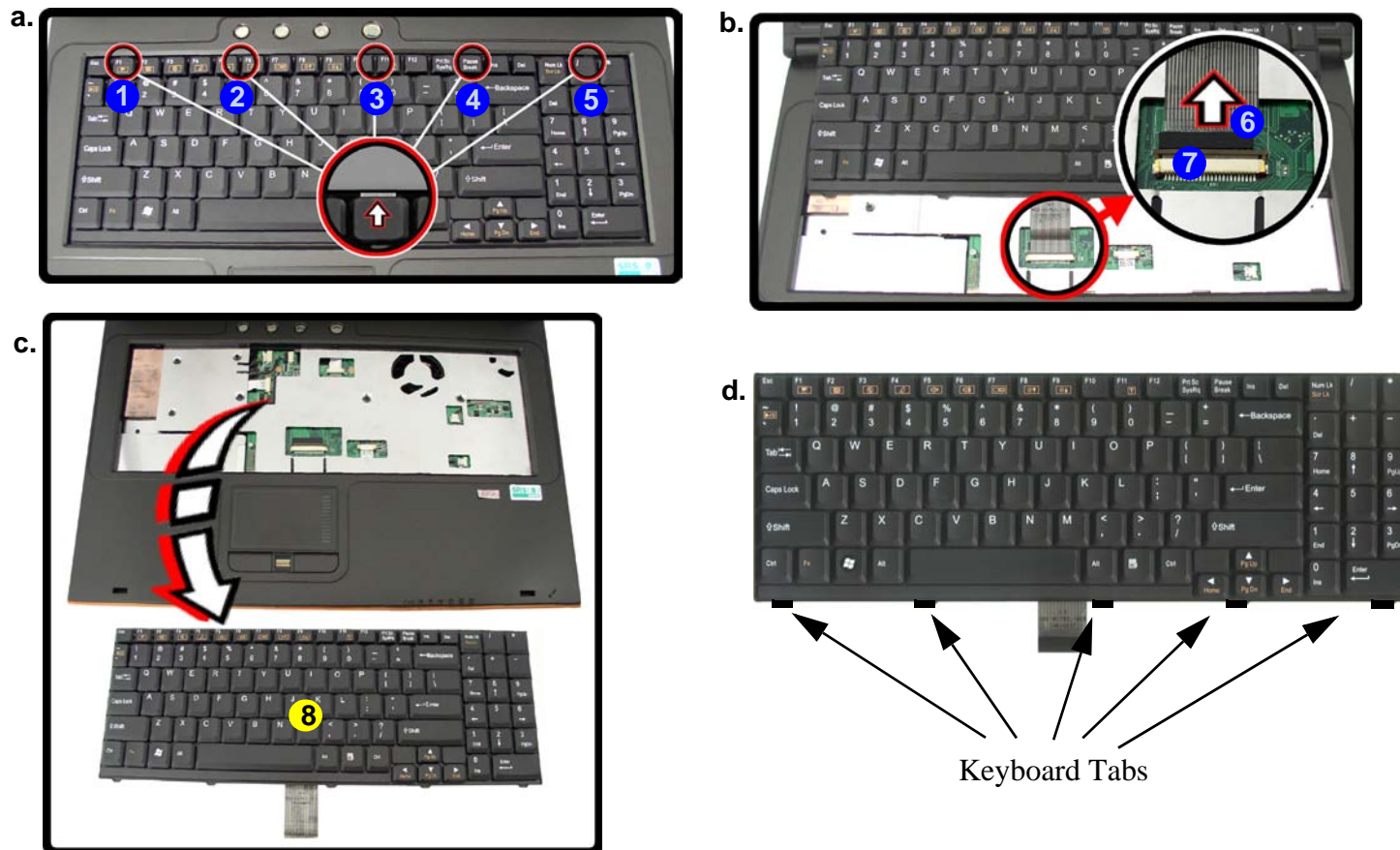



Re-Inserting the Keyboard

When re-inserting the keyboard firstly align the **five** keyboard tabs at the bottom ([Figure 14d](#)) at the bottom of the keyboard with the slots in the case.



8. Keyboard

Figure 15

Modem Removal

- Remove the screws from the keyboard shielding plate.
- Lift the shielding plate off the computer.
- Disconnect the connectors.
- Disconnect the connectors and remove the screws.

Removing the Modem

- Turn **off** the computer, turn it over and remove the battery ([page 2 - 6](#)), hard disk ([page 2 - 7](#)), optical device ([page 2 - 9](#)), RAM ([page 2 - 10](#)), CPU ([page 2 - 11](#)), VGA card ([page 2 - 13](#)), wireless LAN ([page 2 - 15](#)), TV Tuner ([page 2 - 16](#)), Bluetooth ([page 2 - 18](#)) and keyboard ([page 2 - 19](#)).
- Remove screws **1 - 6** from the keyboard shielding plate **7**.
- Lift the keyboard shielding plate **7** off the computer.
- Carefully disconnect connectors (**8 - 15**) and turn the computer over.
- Disconnect connectors (**16 - 19**) and remove screws **20 - 38** from the bottom case ([Figure 15d](#)) and remove screws **39 - 46** from the rear of the computer.

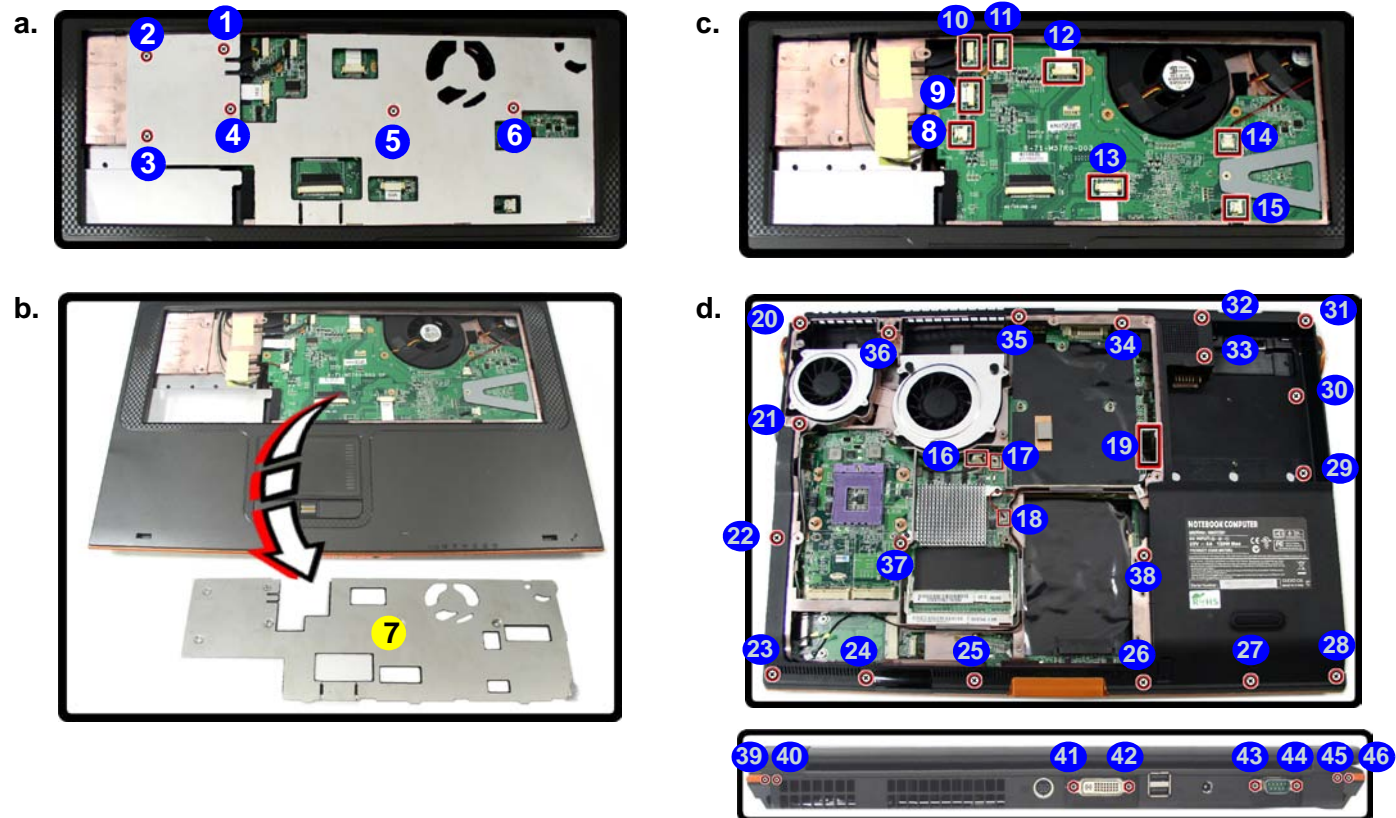



7. Keyboard Shielding Plate

- 33 Screws

6. Carefully lift the top case **47** (*Figure 16e*) up and off the computer.
7. Remove screws **48** - **49** from the mainboard.
8. Lift the mainboard **50** (*Figure 16g*) up and off the bottom case and turn over the mainboard.
9. Remove screws **51** - **52** from the modem and disconnect cable **53**.
10. Lift the modem **54** (*Figure 16i*) up and off the computer.

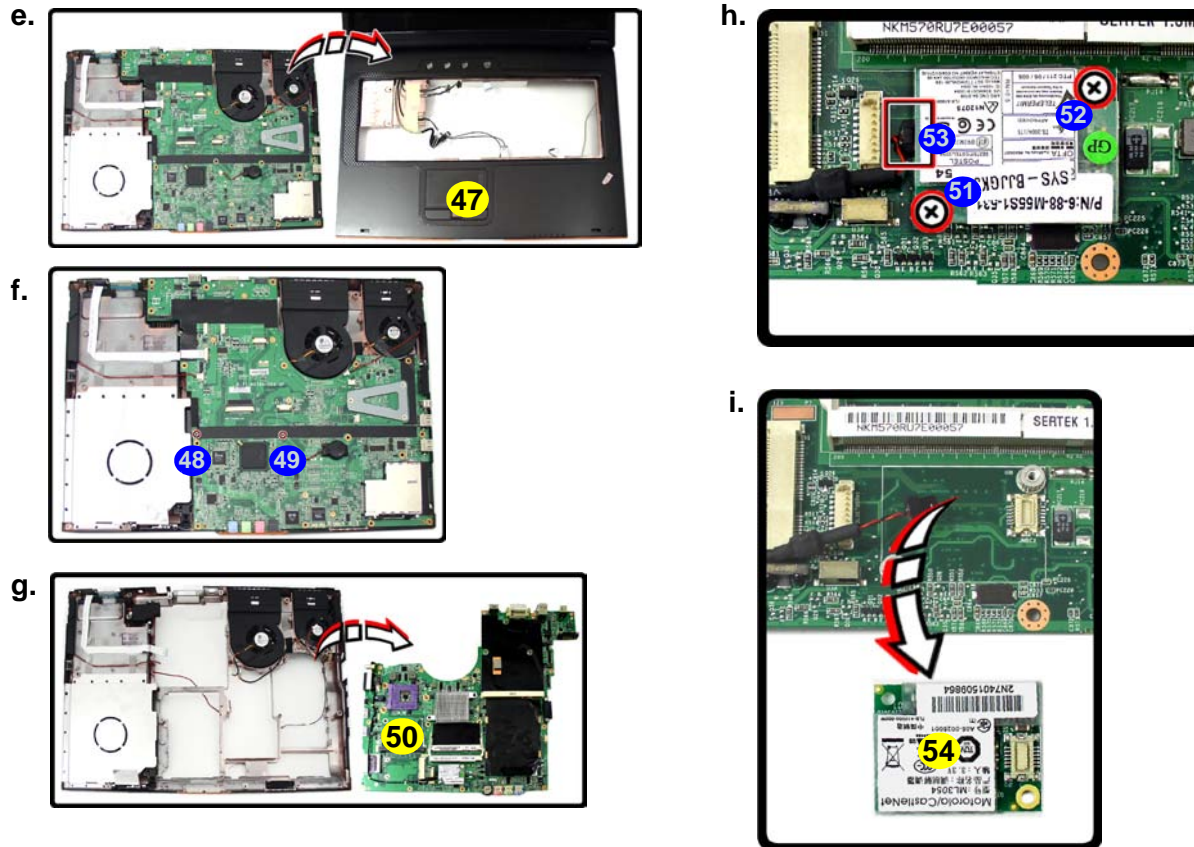

Figure 16
Modem Removal
(cont'd)

- e. Lift the top case off the computer.
- f. Remove the screws.
- g. Lift the mainboard off the bottom case.
- h. Remove the screws and disconnect the cable.
- i. Lift the modem off the computer.



47. Top Case
50. Mainboard
54. Modem

- 4 Screws

Disassembly

Figure 17
Inverter Board
Removal

- a. Remove the 7 screws and unsnap the LCD front panel module from the back.
 - b. Remove the screw and discharge the remaining power from the inverter board and lift the board up slightly.
 - c. Disconnect the cables from the inverter.
 - d. Remove the inverter.
1. Turn **off** the computer, and remove the battery ([page 2 - 6](#)).
 2. Remove any rubber covers, screws **1** - **7** ([Figure 17a](#)), then run your finger around the middle of the frame to carefully unsnap the LCD front panel module **8** from the back.
 3. Discharge the remaining system power (see [“Inverter Power Warning”](#) below).
 4. Remove screw **9** ([Figure 17b](#)) from the inverter, and carefully lift the inverter board up slightly.
 5. Disconnect cables **10** & **11** ([Figure 17c](#)) from the inverter, then remove the inverter **12** ([Figure 17d](#)) from the top case assembly.

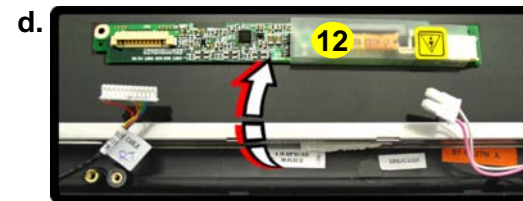
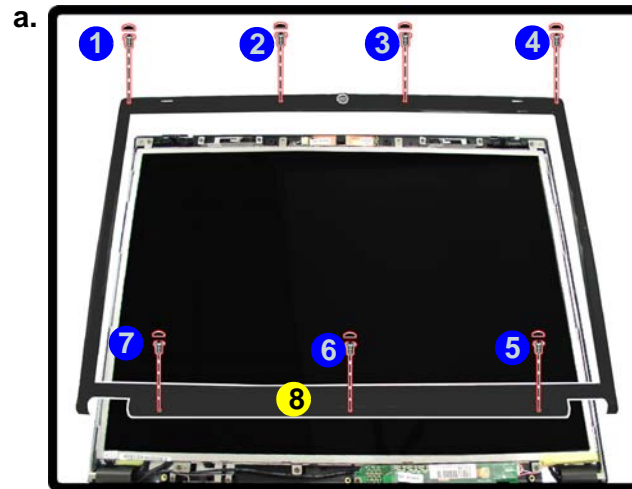

8. LCD Front Panel
12. Inverter Board

- 8 Screws



Inverter Power Warning

In order to prevent a short circuit when removing the inverter it is necessary to discharge any remaining system power. To do so, press the computer's power button for a few seconds before disconnecting the inverter cable.

Appendix A:Part Lists

This appendix breaks down the *M570TU* series notebook's construction into a series of illustrations. The component part numbers are indicated in the tables opposite the drawings.

Note: This section indicates the *manufacturer's* part numbers. Your organization may use a different system, so be sure to cross-check any relevant documentation.

Note: Some assemblies may have parts in common (especially screws). However, the part lists DO NOT indicate the total number of duplicated parts used.

Note: Be sure to check any update notices. The parts shown in these illustrations are appropriate for the system at the time of publication. Over the product life, some parts may be improved or re-configured, resulting in *new* part numbers.

Part List Illustration Location

The following table indicates where to find the appropriate part list illustration.

Table A - 1
**Part List Illustration
Location**

Part	M570TU
Top with Fingerprint	<i>page A - 3</i>
Top without Fingerprint	<i>page A - 4</i>
Bottom	<i>page A - 5</i>
LCD	<i>page A - 6</i>
DVD Combo Drive	<i>page A - 7</i>
DVD Super- Multi Drive	<i>page A - 8</i>

Top with Fingerprint

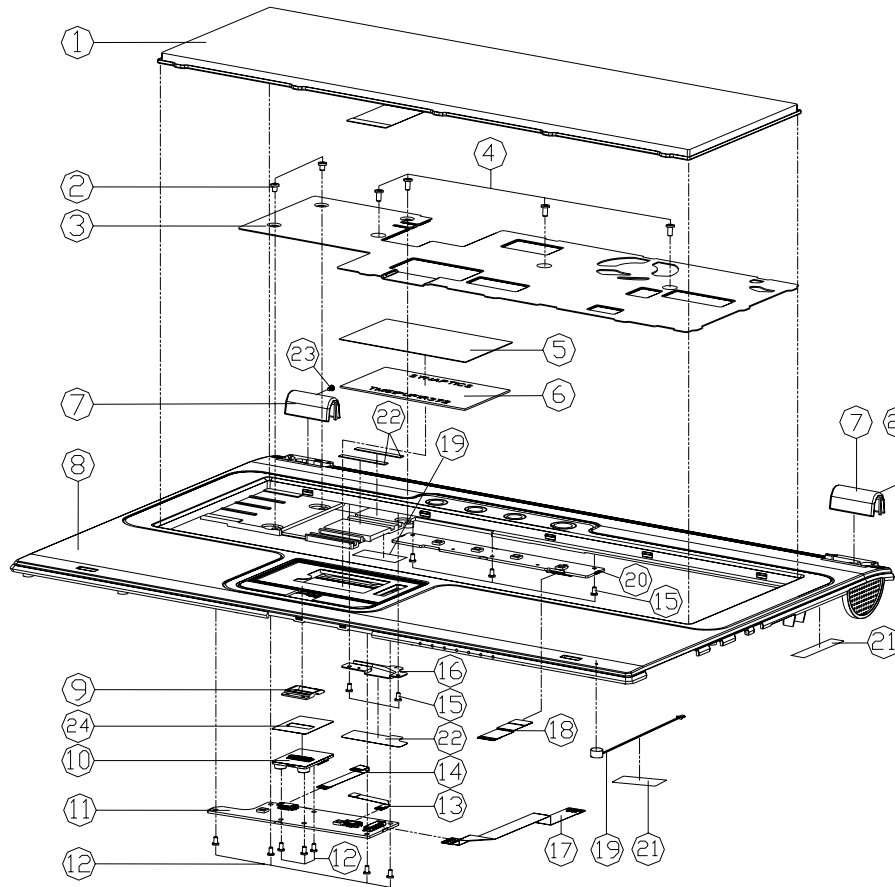

Figure A - 1
Top with Finger-
print

ITEM	PART NAME	PART NO	REMARK
1	KEYBOARD(OPTION)	6-80-D90C0-010-1	
2	SCREW M2.5x4L 1 BK/Z ICT (04.5;10.8)	6-35-C6125-4RA	
3	KEYBOARD SHIELDING SUS M570RU (04.75)	6-33-M57R2-044	
4	SCREW M2.5x6L KI BK/Z NY ICT	6-35-B6125-8R0	
5	TOUCH PAD MYLAR M570RU	6-40-M57R2-011	
6	TOUCH PAD SYNAPTICS 1MS1PUIZ1372	6-49-M57U2-010	
7	HINGE COVER L/R PC+ABS M570RU	6-42-M57RY-011	
8	TOP CASE MODULE (BK/A382)	6-39-M5702-013	
9	FINGER PRINT TOP CASE PC+ABS M570RU	6-42-M57R2-022	
10	FINGER PRINT BOARD V1.0 M570FU	6-77-M570F-D01	
11	CLICK BOARD V1.0 M570TU	6-77-M5702-D01	
12	SCREW M2.5x5L KI BK/Z ICT NY	6-35-B6125-5RA	
13	PC CABLE FOR FINGERPRINT # P100-01 (L-200)	6-43-M57RF-011	
14	PC CABLE FOR CLICK BOARD # P100-01 (L-200)	6-43-M57RO-031	
15	SCREW M2x4L KI BNI ICT NY	6-35-B9120-4RA	
16	CABLE COVER SUS430 M570RU	6-33-M57R2-050	
17	PC CABLE FOR CLICK BOARD # P100-01 (L-200)	6-43-M57RO-011	
18	PC CABLE FOR KEY BOARD # P100-01 (L-200)	6-43-M57RO-040	
19	MIC (04x3.4x1.4) 2V-3V 22K 2P W/CABLE	6-23-EM56A-011	
20	HOT KEY BOARD V2.0 M570RU	6-77-M57RS-D02	
21	TAPE MYLAR (C)MYLAR M550J	6-40-M55J2-030	
22	CABLE COVER MYLAR M570RU	6-40-M57R2-020	
23	SCREW M2x3 KI BZ ICT NY (03x4.5;11-04)	6-35-B6120-3RD	
24	FINGER PRINT PCB MYLAR M570RU	6-40-M57RS-011	

A.Part Lists

Top without Fingerprint

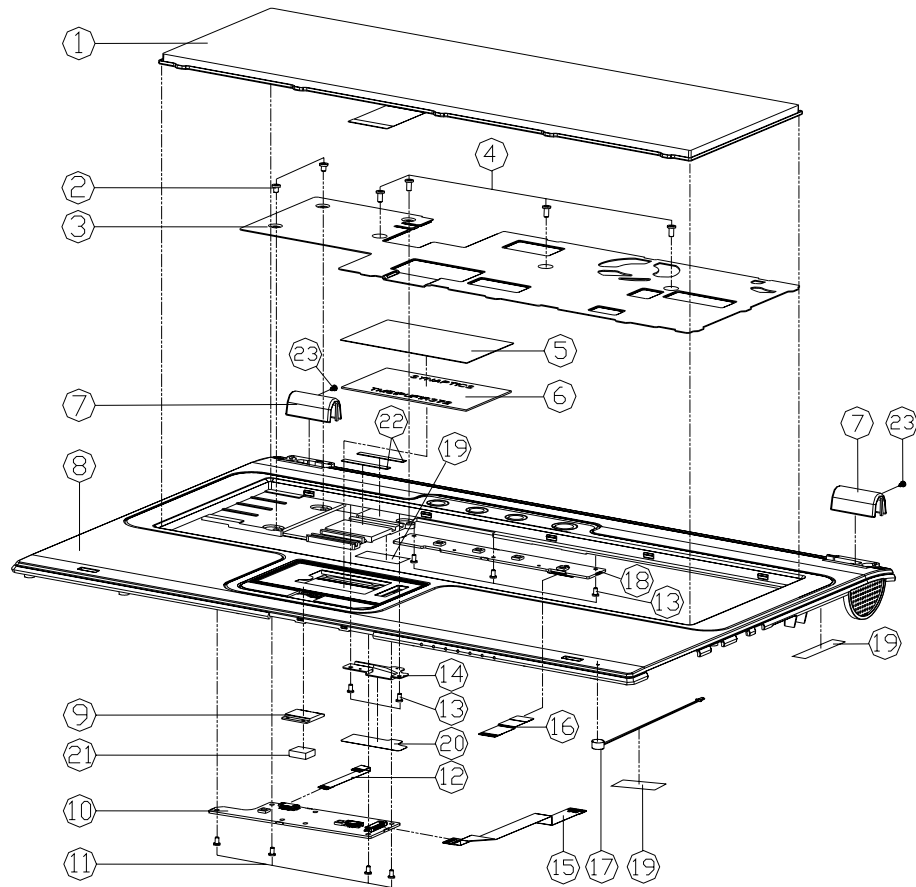
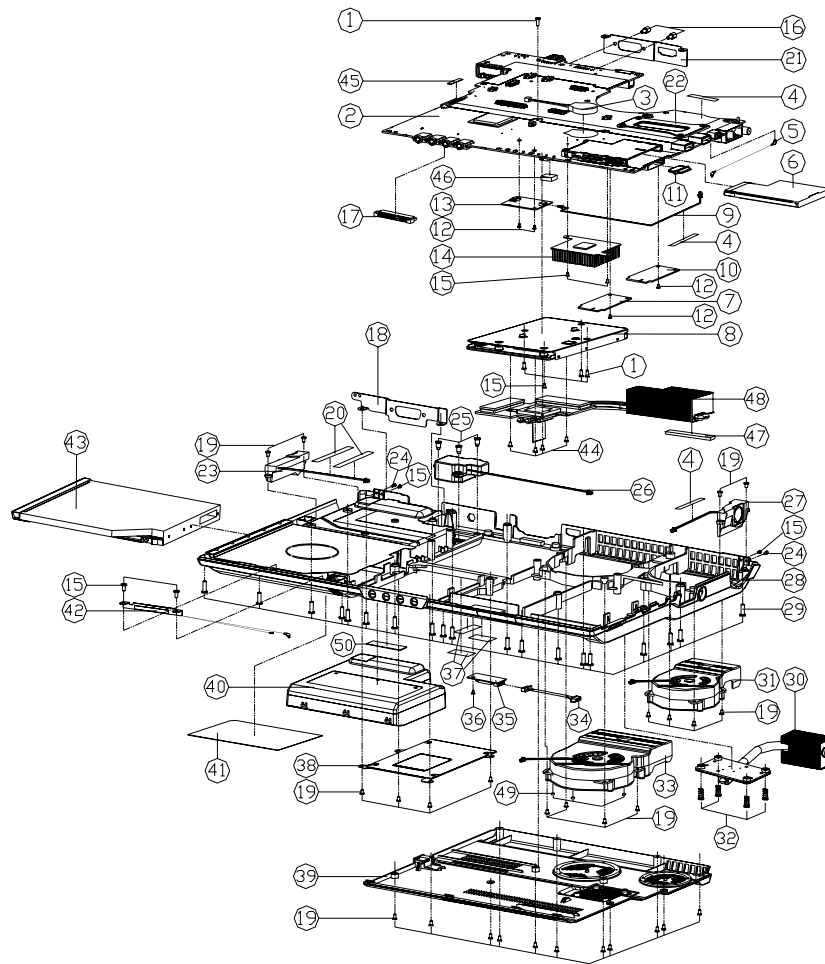

Figure A - 2
Top without
Fingerprint

A.Part Lists

ITEM	PART NAME	PART NO	REMARK
1	KEYBOARD(OPTION)	6-80-D90C0-010-1	
2	SCREW M2.5x4L I BK/Z ICT (04.5108)	6-35-C6125-4RA	
3	KEYBOARD SHIELDING SUS M570RU (06P10)	6-33-M57R2-044	
4	SCREW M2.5x8L KI BK/Z NY ICT	6-35-B6125-0R0	
5	TOUCH PAD MYLAR M570RU	6-40-M57R2-011	
6	TOUCH PAD SYNAPTICS 1MS1PUI372	6-49-M57U2-010	
7	HINGE COVER L/R PC+ABS M570RU	6-42-M57RY-011	
8	TOP CASE MDDULE M570TU	6-39-M5702-013	
9	FINGER PRINT DUMMY COVER PC+ABS M570RU	6-42-M57R2-082	
10	CLICK BOARD V1.0 M570TU	6-77-M5702-D01	
11	SCREW M2.5x5L KI BK/Z ICT NY	6-35-B6125-SRA	
12	ITE CABLE FOR CLK BOARD 2P PRO-40 (L-40MM) M570RU	6-43-M57R0-031	
13	SCREW M2x4L KI BNI ICT NY	6-35-B9120-4RA	
14	CABLE COVER SUS430 M570RU	6-33-M57R2-050	
15	ITE CABLE FOR CLK BOARD 2P PRO-41 (L-42MM) M570RU	6-43-M57R0-011	
16	ITE CABLE FOR HOT KEY BOARD 2P PRO-41 (L-42MM) M570RU	6-43-M57R0-040	
17	MIC 6MMx34MMx6.5MM 2V-10V 2K 2P W/CABLE	6-23-EM56A-011	
18	HOT KEY BOARD V2.0 M570RU	6-77-M57RS-D02	
19	TAPE MYLAR (C)MYLAR M550J	6-40-M55J2-030	
20	CABLE COVER MYLAR M570RU	6-40-M57R2-020	
21	BUKBER25MS4919FCR FINGER PRINTER DUMMY M570RU	6-47-M57R2-010	
22	SPONGE (L33xW5xH0.65MM)	6-47-M6651-010	
23	SCREW M2x3L KI BK ICT NY (00-M5.01-04)	6-35-B6120-3RD	

Bottom



ITEM	PART NAME	PART NO	REMARK
1	SCREW M2.5x4.0 K BZ ICT NY	6-35-B2125-6RA	
2	MAIN BOARD V3.0B M570TU	6-77-M5700-003B	
3	HEAT SINK FOR CPU M570TU	6-23-22015-PPC	
4	TAPE MYLAR (20)MYLAR M550J	6-40-M55J2-010	
5	DATA CABLE FOR SATA M570TU	6-43-L22CT-010	
6	KEY CARD BLANK (E) M570TU	6-42-M57RP-012	
7	VIA BOARD M570TU	6-88-M55S2-7000	(OPTION)
7	VIA BOARD M570TU INTEL SHIELD PEAK QM7	6-88-M7212-4210	(OPTION)
7	VIA BOARD M570TU INTEL SHIELD PEAK 102	6-88-M7212-4240	(OPTION)
7	VIA BOARD M570TU INTEL SHIELD PEAK 303	6-88-M7412-4200-1	(OPTION)
8	VIA BOARD M570TU M570TU AND G400	6-77-M570L-0A0	(OPTION)
8	VIA BOARD M570TU M570TU AND G400	6-77-M570L-0A0	(OPTION)
8	VIA BOARD M570TU M570TU AND G400	6-77-M570L-0A0	(OPTION)
9	MODE CABLE M570TU	6-43-M570R-010	
10	DATA CABLE FOR SATA M570TU	6-43-L22CT-670	(OPTION)
10	DATA CABLE FOR SATA M570TU	6-88-M5787-6540	(OPTION)
11	M570TU CARD READER RUBBER	6-47-M5208-010	
12	SCREW M2x4.0 KI NI ICT CITY-PATCH	6-35-B1120-3RE	
13	HEAT SINK FOR CPU M570TU	6-88-L3911-5300	(OPTION)
13	HEAT SINK FOR CPU M570TU	6-88-M66S1-620	(OPTION)
14	HEAT SINK FOR CPU M570TU	6-31-M57RN-301	
15	SCREW M2x4.0 KI BZ ICT NY	6-35-B6120-4RA	
16	HEAT SINK FOR CPU M570TU	6-24-07009-012	
17	DATA CABLE FOR SATA M570TU	6-21-14000-12E	
18	ID BRACKET FOR CPU M570TU	6-33-M57RS-011	
19	SCREW M2.5x4.0 KI BK/VD ICT NY	6-35-B4125-4RA	
20	TAPE MYLAR (20)MYLAR M550J	6-40-M55J2-010	
21	ID BRACKET DIV1 SUS430 M570T	6-33-M570S-021	
22	CPU SUPPORTER MODULE M570TU	6-33-M570S-102	
23	SCREW M2.5x4.0 KI BK/VD ICT NY	6-23-SM57R-021	
24	SCREW M2x4.0 KI BK/VD ICT NY	6-35-B6120-8R0	
25	SCREW FOR SPEAKER M570TU	6-35-Z0220-000	
26	SCREW FOR CPU M570TU	6-23-SM57R-030	
27	SCREW FOR CPU M570TU	6-23-SM57R-011	
28	BOTTOM CASE MIDDLE M570TU	6-39-M5703-013	
29	SCREW M2.5x4.0 KI BK/VD NY ICT	6-35-B6125-8R0	
30	CPU HEAT SINK FOR M570TU	6-31-M570N-020	
31	CPU FAN M570TU	6-31-M570S-100	
32	CPU FAN M570TU	6-31-41025-095	
33	VIA FAN M570TU	6-31-M57RS-204	
34	BLUETOOTH CABLE FOR M570TU	6-43-M66N8-010	(OPTION)
35	HEAT SINK FOR CPU M570TU	6-88-M5545-660	
35	HEAT SINK FOR CPU M570TU	6-88-M5545-390	
36	SCREW M2.5x4.0 KI BZ ICT NY	6-35-B6125-3R0	
37	TAPE MYLAR (20)MYLAR M550J	6-40-M55J2-030	
38	MODE BRACKET SUS304 M570TU	6-33-M57R-J-011	
39	CPU COVER X7900 MODULE FOR M570TU	6-42-M57RS-101	
40	MODE BRACKET FOR M570TU	6-87-M57AS-4L41	(OPTION)
40	MODE BRACKET FOR M570TU	6-87-M57AS-4D42	(OPTION)
40	MODE BRACKET FOR M570TU	6-87-M57RS-4DE	(OPTION)
41	PRODUCT LABEL FOR M570TU	6-45-M5703-010	
42	HEAT SINK FOR CPU M570TU	6-23-M57R-041	(OPTION)
43	SATA IDE CABLE FOR M570TU	6-79-M570L00-010	(OPTION)
43	SATA IDE SUPER MULTI 24X8 ASST M570TU	6-79-M570L00-000	(OPTION)
44	SCREW M2x4.0 KI NI ICT NY	6-35-B1120-3RA	
45	MODE BRACKET FOR M570TU	6-47-P2101-020	
46	MODE BRACKET FOR M570TU	6-47-00190-13G	
46	MODE BRACKET FOR M570TU	6-47-00190-05B	
48	VIA HEATING PIPE MODULE FOR M570TU	6-31-M57RN-921	
49	VIA FAN RUBBER FOR M570TU	6-47-M57RS-080	
50	MODE BRACKET FOR M570TU	6-47-M57RM-010	

Figure A - 3
Bottom

A.Part Lists

LCD

Figure A - 4
LCD

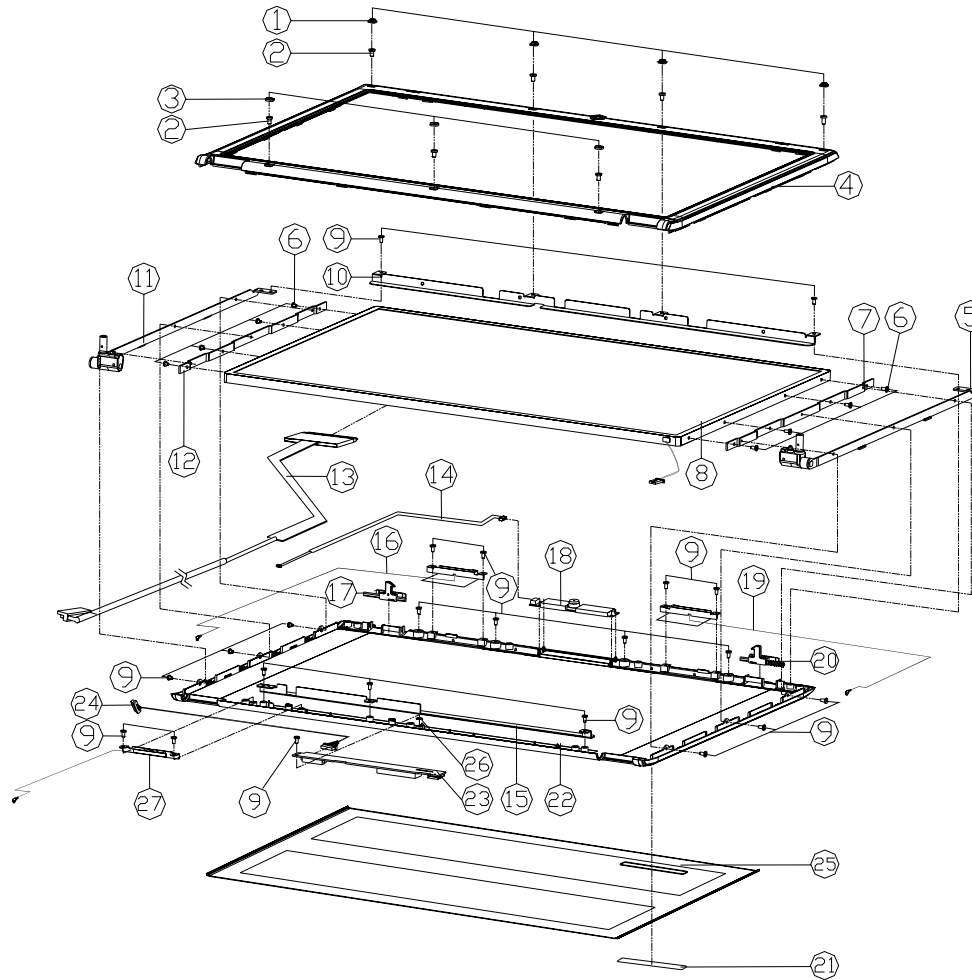

ITEM	PART NAME	PART NO	REMARK
1	RUBBER LCD TOP	6-47-M57A1-011	
2	SCREW M2.5*5L KI NI ICT NY	6-35-B112S-SRA	
3	RUBBER LCD DOWN M570RU	6-47-M57R3-030	
4	LCD FRONT COVER MODULE M570RU	6-39-M57R1-011	
5	LCD HINGE ASSY R	6-33-M57A1-DA1	
6	SCREW M2*3L KI NI ICT NY	6-35-B1120-3RA	
7	CONVERT BRACKET R FOR LG 17" M570RU	6-33-M57R1-030	FDR LG
7	CONVERT BRACKET R FOR LG17	6-33-M57A1-060	FDR AU
8	LCD 17" WING LG 1717MM-TLR GLASS TYPE	6-50-NB265-L02	FDR LG
8	LCD 17" AU WINGV2 17.17" WING GLASS TYPE	6-50-N7268-G00	FDR AU
8	LCD 17" WING AU WINGV2 V2 GLASS TYPE	6-50-NB266-G00	FDR AU
9	SCREW M2*4L KI BNI ICT NY	6-35-B9120-4RA	
10	LCD BRACKET TOP FOR AU17	6-33-M57A1-051	
11	LCD HINGE ASSY L	6-33-M57A1-0B1	
12	CONVERT BRACKET L FOR LG17	6-33-M57A1-070	
13	LCD CABLE LVDS M570TU	6-43-M5701-011	
14	CAMERA CABLE SP ANGR USER WIRE L=480MM	6-43-M570T-020	
15	LCD BRACKET DOWN	6-33-M57A1-0B1	
16	ANTENNA WLAN 2.4G/3.5G PIFA W/ GLASS	6-23-7M570-021	
17	HOLD KNEE L 06200MPP9-488	6-42-M57R1-080	
18	UVX CAMERA BISON TX BKCS457-800 2M W/40C	6-88-M5E4C-4913	(OPTION)
18	UVX CAMERA BISON TX BKCS457-800 2M W/40C	6-88-M5E4C-4913	(OPTION)
19	ANTENNA WLAN 2.4G/3.5G PIFA W/ GLASS	6-23-7M570-010	
20	HOLD KNEE R MODULE M570RU 4MPP9-488	6-42-M57R1-700	
21	FDR M540G WITH LOGO STYLE -NOTICE	6-45-M54G1-020	
22	LCD BACK COVER MODULE M570TU	6-39-M5701-021	
22	LCD BACK COVER MODULE M570TU	6-39-M5711-023	
23	INVERTER CABLE IN SMD TYPE-40-963	6-76-M57RR-010	
24	INVERTER CABLE OF ANGLE L=300MM	6-43-M570R-010	
25	AL PLATE FOR BACK COVER 099-17460	6-33-M57R1-011	
25	AL PLATE FOR BACK COVER 08103	6-33-M5711-0C0	
26	WASHER 06*0.3*0.34 (MYLAR)	6-37-02000-601	
27	ANTENNA WLAN 2.4G/3.5G PIFA W/ GLASS	6-23-7M570-030	

DVD Combo Drive

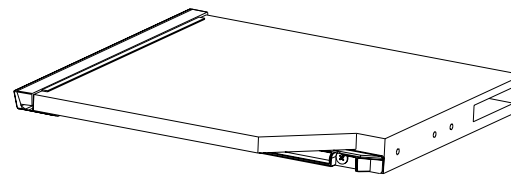
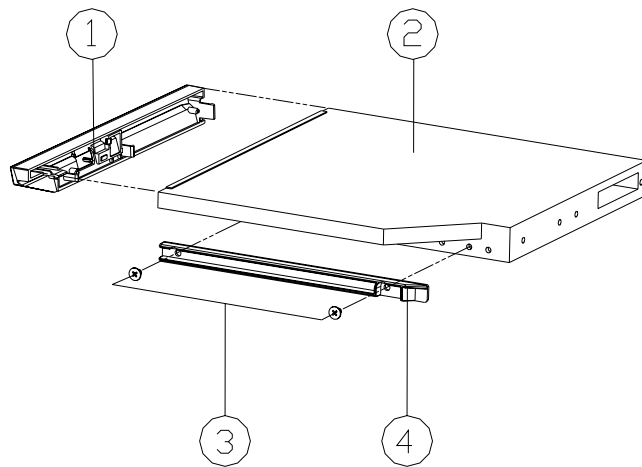
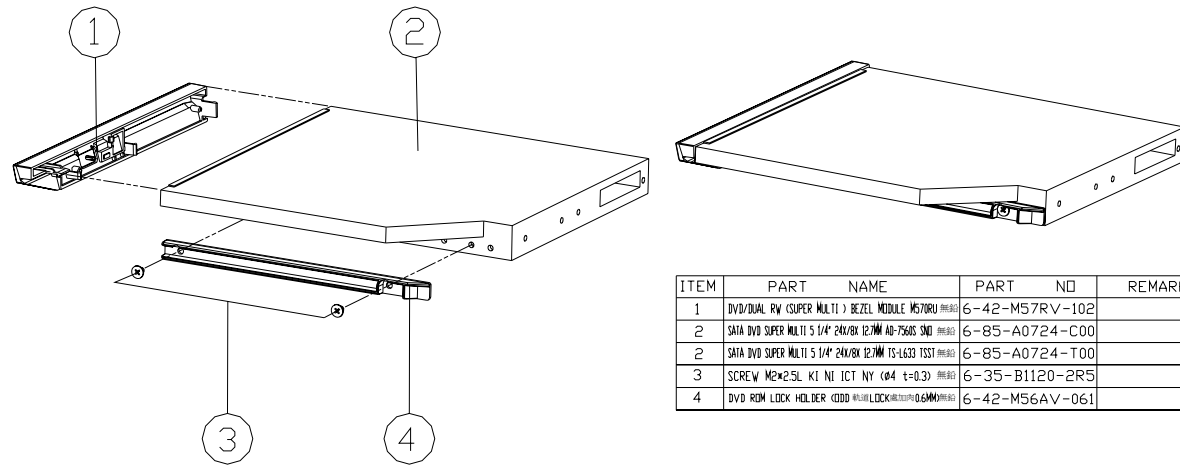

Figure A - 5
DVD Combo Drive

ITEM	PART NAME	PART NO	REMARK
1	DVD COMBO BEZEL MODULE M570RU 無鉛	6-42-M57RX-102	
2	SATA DVD COMBO 5 1/4" 24X/8X 12.7MM CRX8905 SMD 無鉛	6-85-90724-C00	
3	SCREW M2*2.5L K1 Ni ICT NY Ø4 t=0.3 無鉛	6-35-B1120-2R5	
4	DVD ROM LOCK HOLDER (ODD) 無鉛	6-42-M56AV-061	

DVD Super-Multi Drive

Figure A - 6
DVD Super-Multi Drive



ITEM	PART NAME	PART NO	REMARK
1	DVD/DUAL RW (SUPER MULTI) BEZEL MIDDLE M570RU (REV.01)	6-42-M57RV-102	
2	SATA DVD SUPER MULTI 5 1/4" 24X/8X 127MM AD-7560S SMD (REV.01)	6-85-A0724-C00	
3	SATA DVD SUPER MULTI 5 1/4" 24X/8X 127MM TS-1.633 TSST (REV.01)	6-85-A0724-T00	
3	SCREW M2*2.5L KI NI ICT NY (Ø4 t=0.3) (REV.01)	6-35-B1120-2R5	
4	DVD ROM LOCK HOLDER (ODD M/L) LOCK (REV.01) (Ø6MM) (REV.01)	6-42-M56AV-061	

Appendix B:Schematic Diagrams

This appendix has circuit diagrams of the *M570TU* notebook's PCB's. The following table indicates where to find the appropriate schematic diagram.

Diagram - Page	Diagram - Page	Diagram - Page
<i>SYSTEM BLOCK DIAGRAM - Page B - 2</i>	<i>ICH9-M 3/4 CASE FAN - Page B - 16</i>	<i>Power Charger, DC IN - Page B - 30</i>
<i>Penryn 1/2 - Page B - 3</i>	<i>ICH9-M 4/4 - Page B - 17</i>	<i>Power GPU - Page B - 31</i>
<i>Penryn 2/2 - Page B - 4</i>	<i>ODD, PC BEEP, USB2.0 & eSATA - Page B - 18</i>	<i>Power 1.5V/ 0.75V - Page B - 32</i>
<i>Cantiga 1/5 Host - Page B - 5</i>	<i>CLOCK GENERATOR, CCD - Page B - 19</i>	<i>Power 1.8VS/ 1.05VS - Page B - 33</i>
<i>Cantiga 2/6 PEG - Page B - 6</i>	<i>PCI-E LAN RTL8111C - Page B - 20</i>	<i>Power 3VS, 5VS, Power S/W - Page B - 34</i>
<i>Cantiga 3/6 DDR - Page B - 7</i>	<i>CARD READER & 1394 JMB380 - Page B - 21</i>	<i>Power VDD3/ VDD5/ 3.3V/ 5V - Page B - 35</i>
<i>Crestline 4/6 POWER1 - Page B - 8</i>	<i>NEW CARD - Page B - 22</i>	<i>Power VCORE for Penryn CPU - Page B - 36</i>
<i>Cantiga 5/6 GND - Page B - 9</i>	<i>KBC-ITE IT8512 - Page B - 23</i>	<i>MINI CARD, CIR - Page B - 37</i>
<i>Cantiga 6/6 POWER2 - Page B - 10</i>	<i>HDMI - Page B - 24</i>	<i>MXM PCI-E TYPE-IV - Page B - 38</i>
<i>DDR3 SO-DIMM 0 - Page B - 11</i>	<i>LED - Page B - 25</i>	<i>Board to board CON - Page B - 39</i>
<i>DDR3 SO-DIMM 1 - Page B - 12</i>	<i>AZALIA CODEC ALC662 - Page B - 26</i>	<i>BUTTON BOARD - Page B - 40</i>
<i>LCD,CPU FAN - Page B - 13</i>	<i>AUDIO AMP - Page B - 27</i>	<i>CLICK Board - Page B - 41</i>
<i>ICH9-M 1/4 SATA - Page B - 14</i>	<i>SRS - Page B - 28</i>	<i>Fingerprint Board - Page B - 42</i>
<i>ICH9-M 2/4 PCI,USB - Page B - 15</i>	<i>CRT, INV, MDC, BT, PWRGD - Page B - 29</i>	<i>DEBUG Board - Page B - 43</i>

Table B - 1
**Schematic
Diagrams**



Version Note

The schematic diagrams in this chapter are based upon version **6-7P-M5705-005**. If your mainboard (or other boards) are a later version, please check with the Service Center for updated diagrams (if required).

SYSTEM BLOCK DIAGRAM

Sheet 1 of 42
SYSTEM BLOCK
DIAGRAM

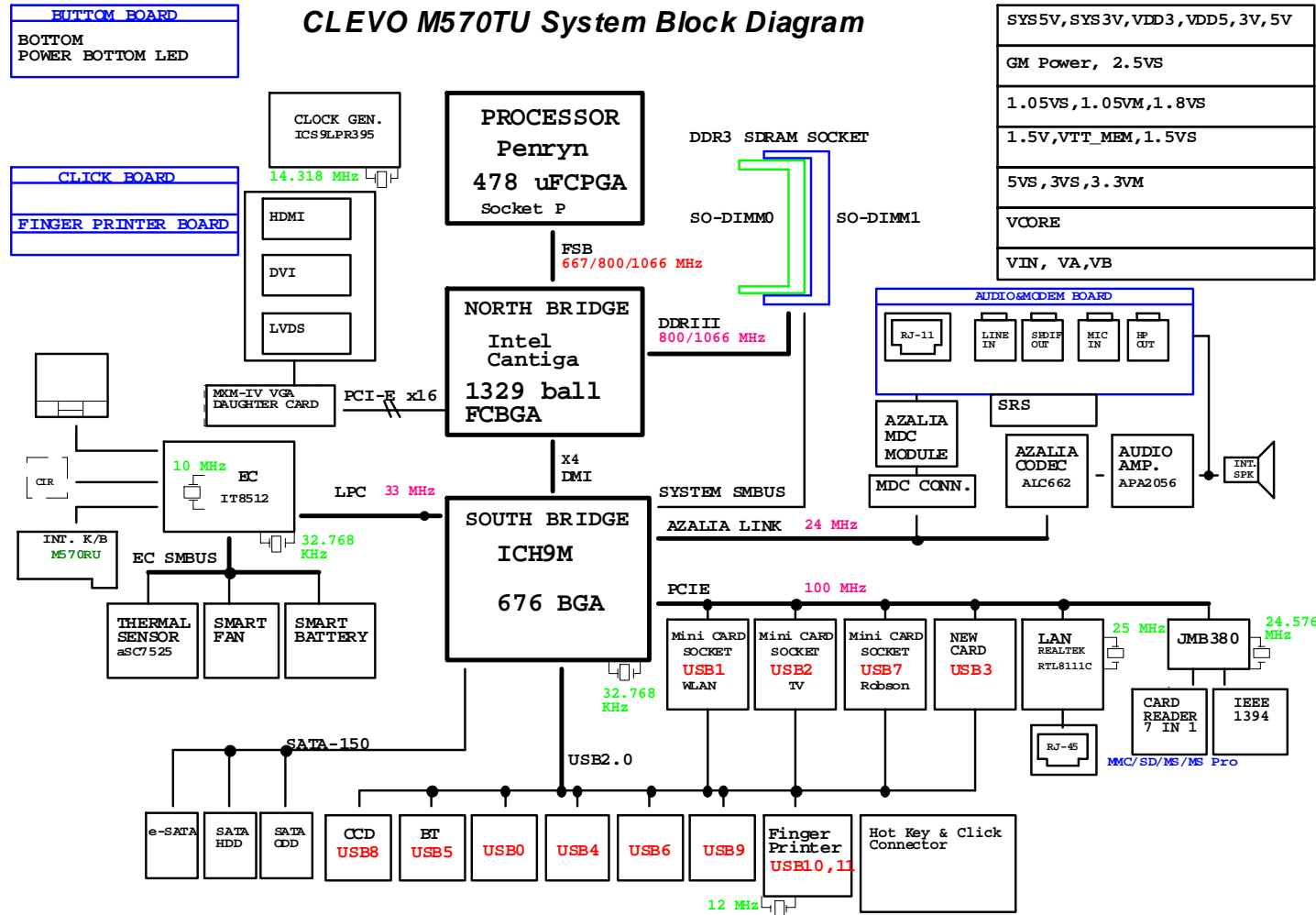

Schematic Diagrams

Penryn 2/2

B.Schematic Diagrams

Sheet 3 of 42
Penryn 2/2

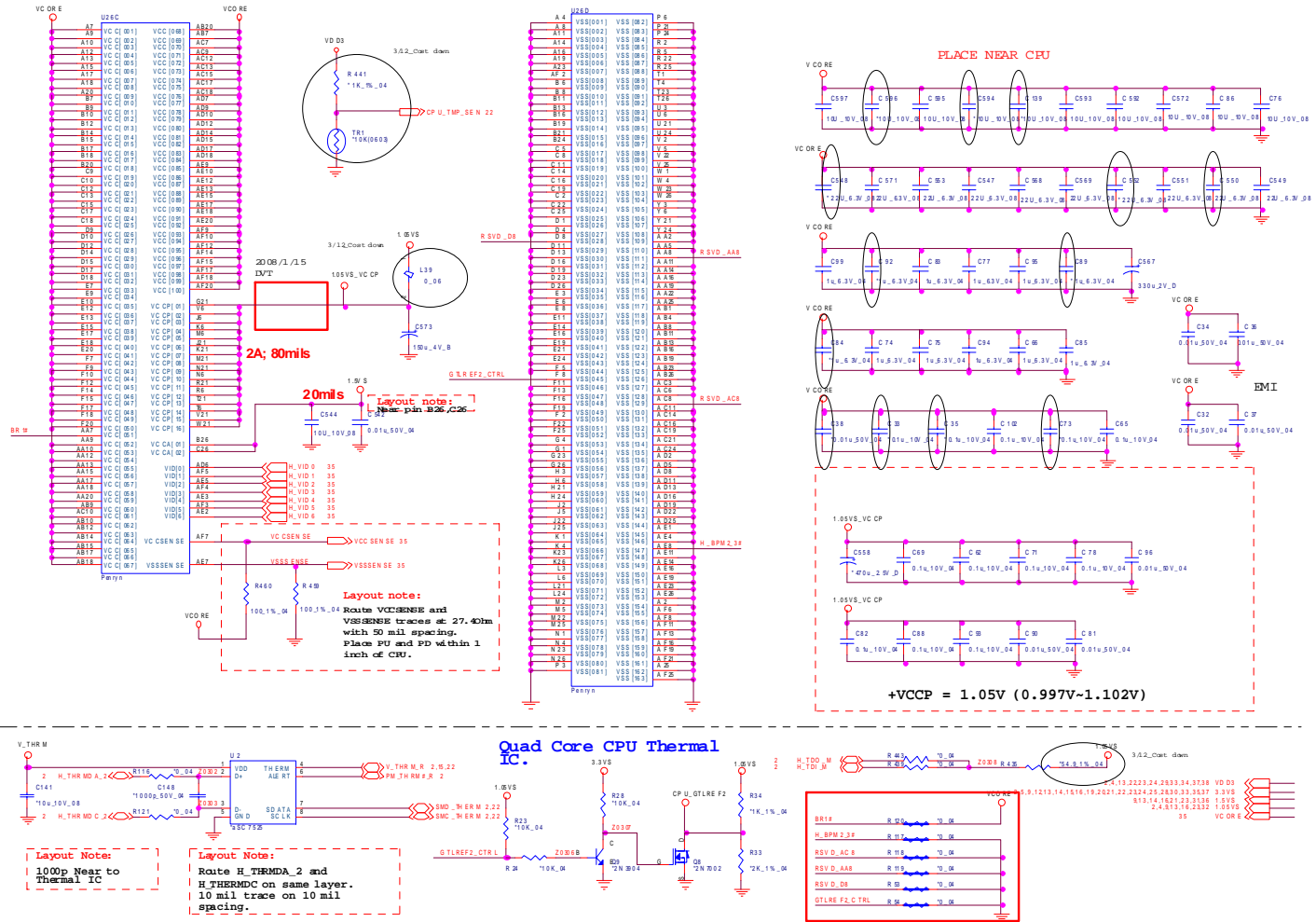

Cantiga 1/5 Host

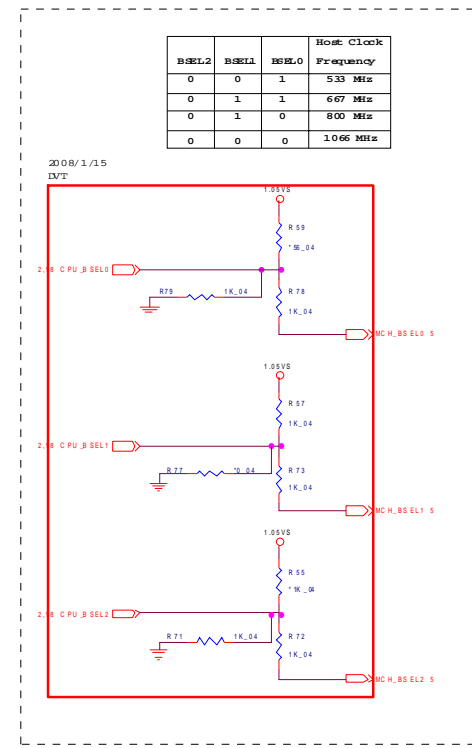
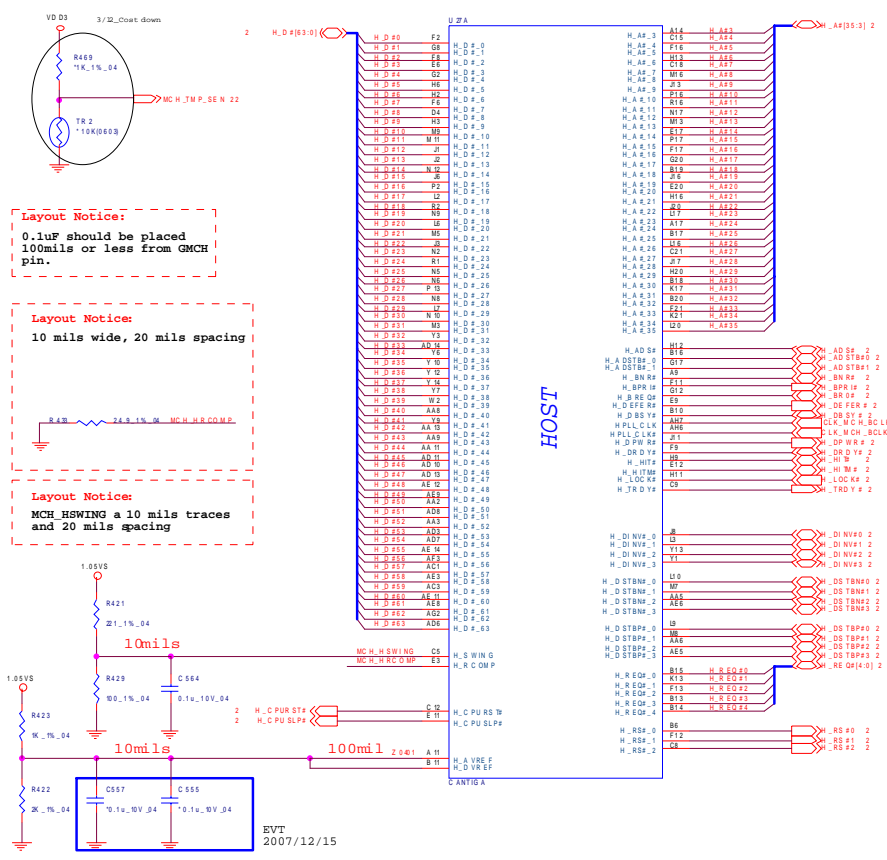

Sheet 4 of 42
Cantiga 1/5 Host

Cantiga 2/6 PEG

Sheet 5 of 42
Crestline 2/6 PEG

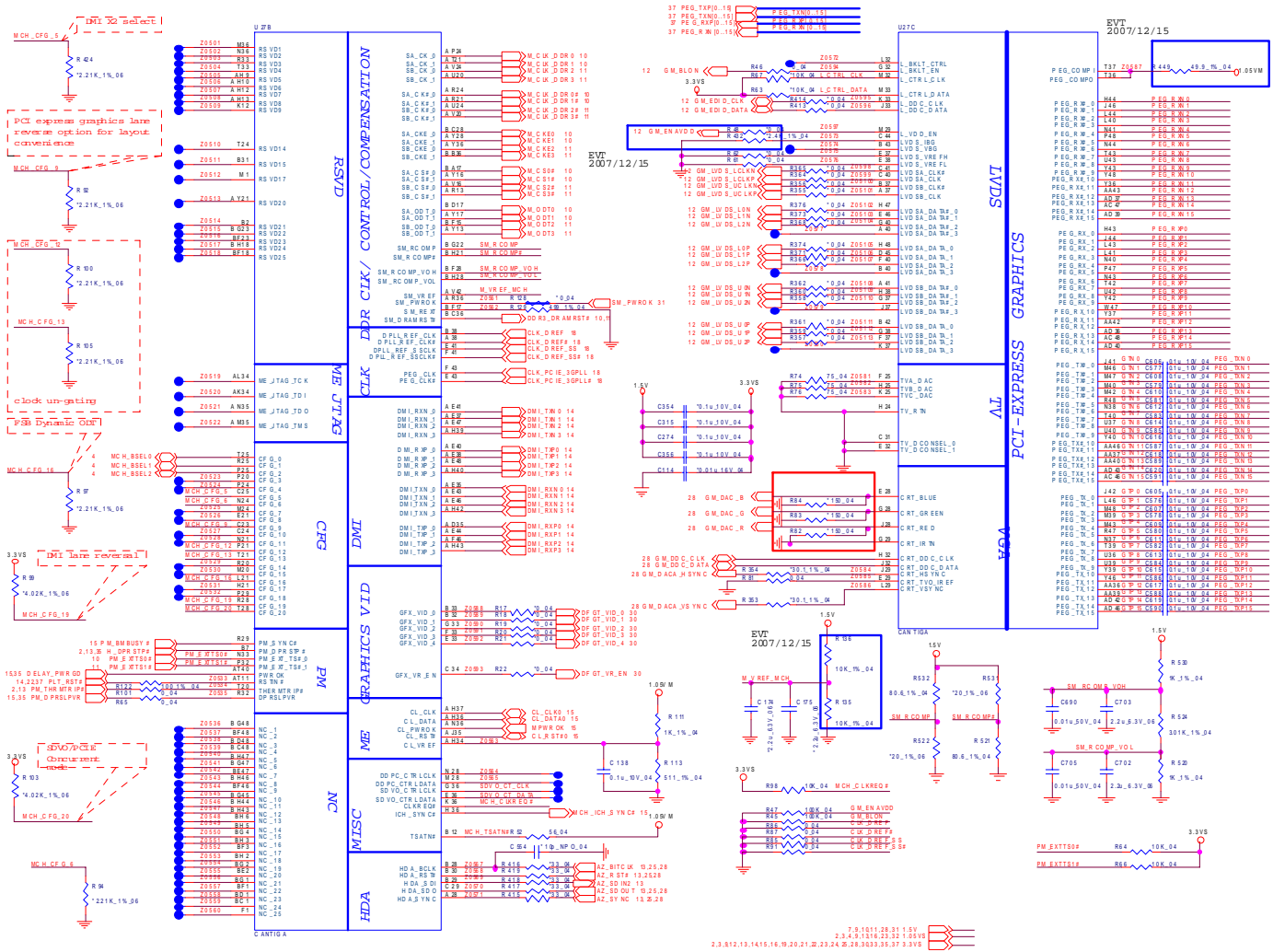

Cantiga 3/6 DDR

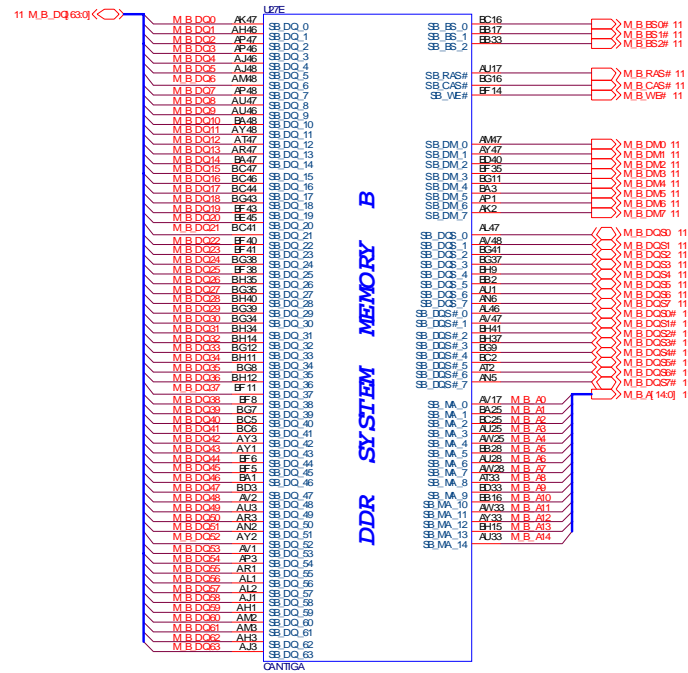
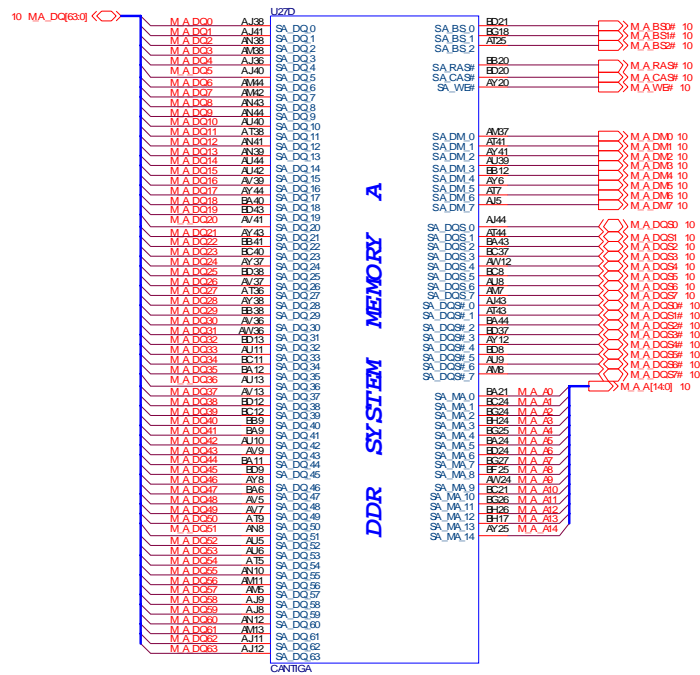

B. Schematic Diagrams

Sheet 6 of 42
Crestline 3/6 DDR

Crestline 4/6 POWER1

Sheet 7 of 42
Crestline 4/6
POWER1

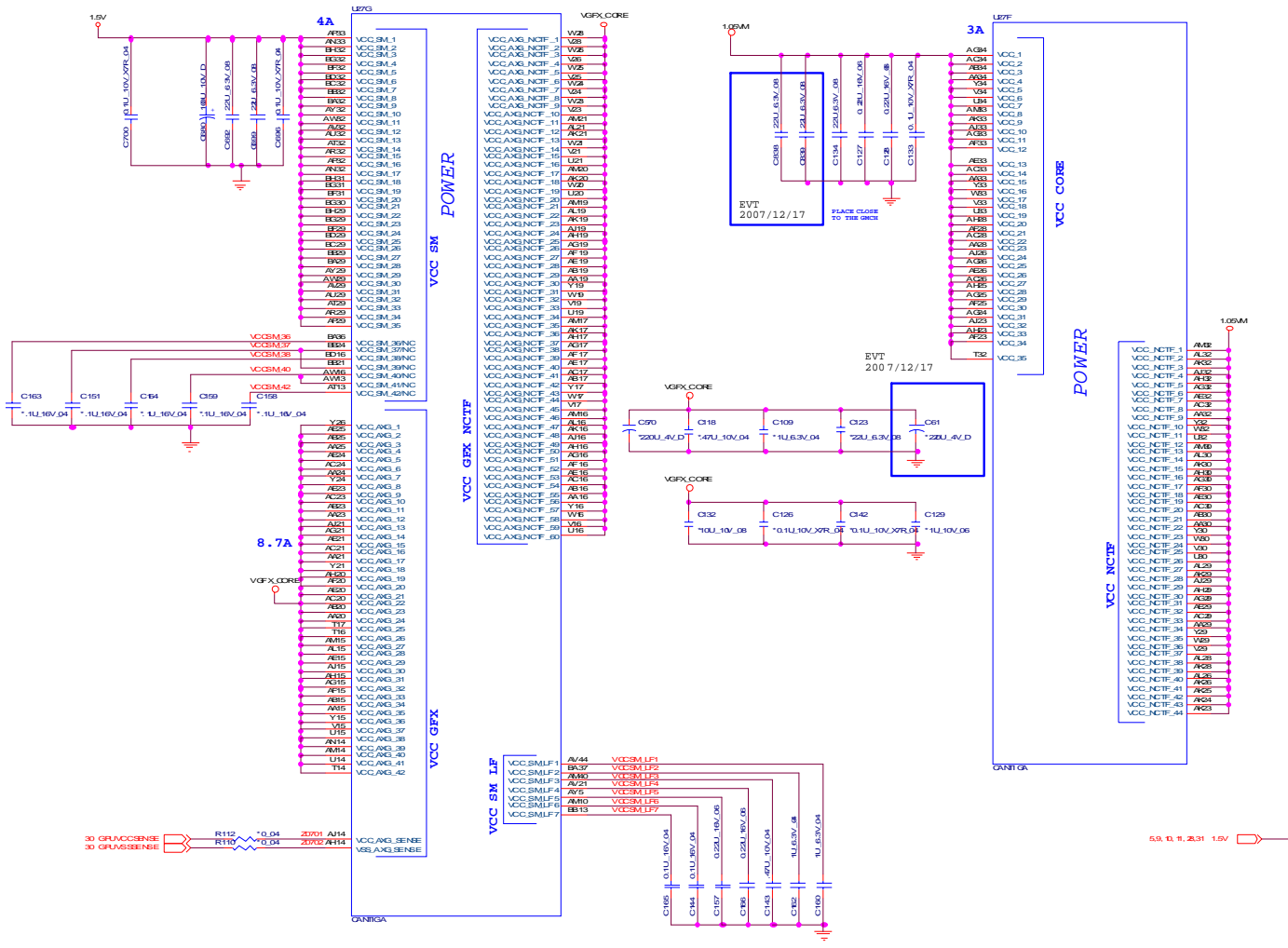

Cantiga 5/6 GND

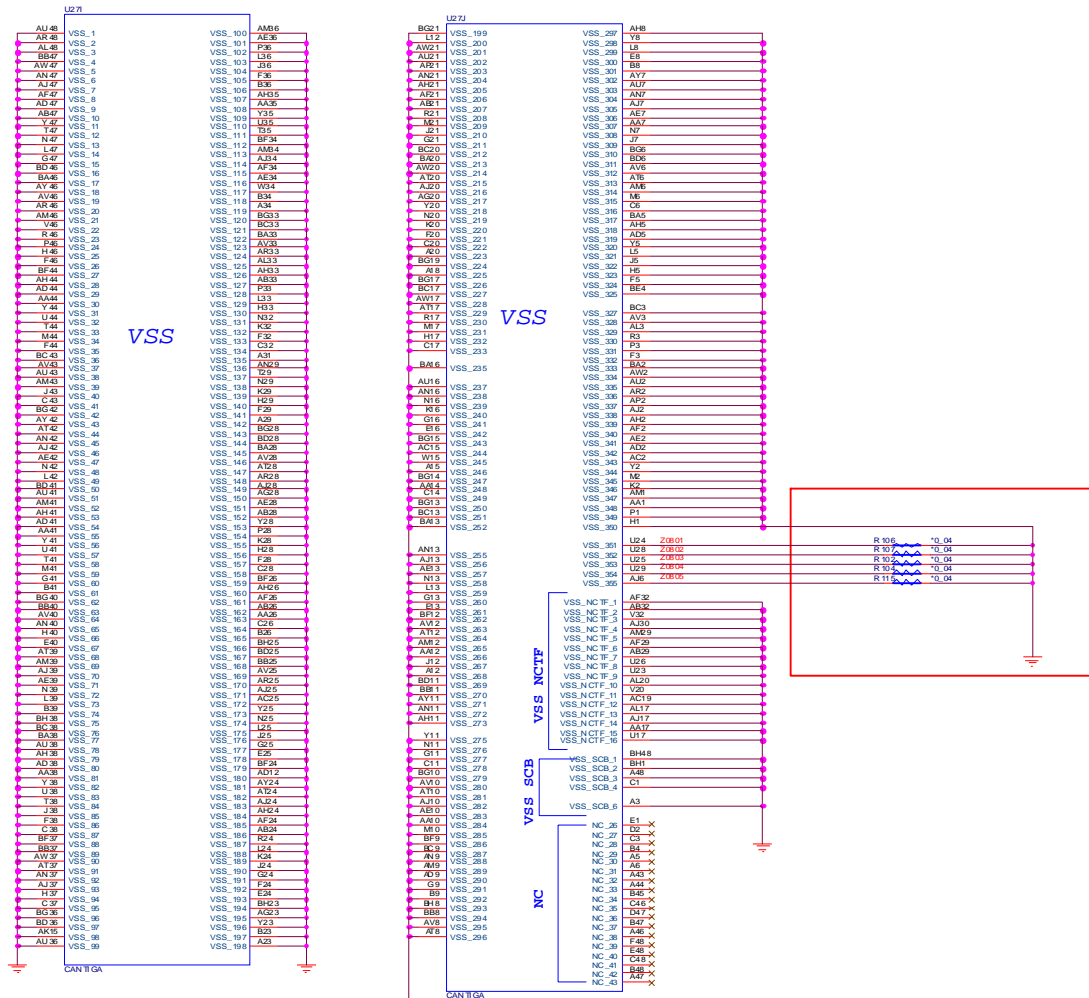

Sheet 8 of 42
Cantiga 5/6 GND

B.Schematic Diagrams

Cantiga 6/6 POWER2

Sheet 9 of 42
Cantiga 6/6
POWER2

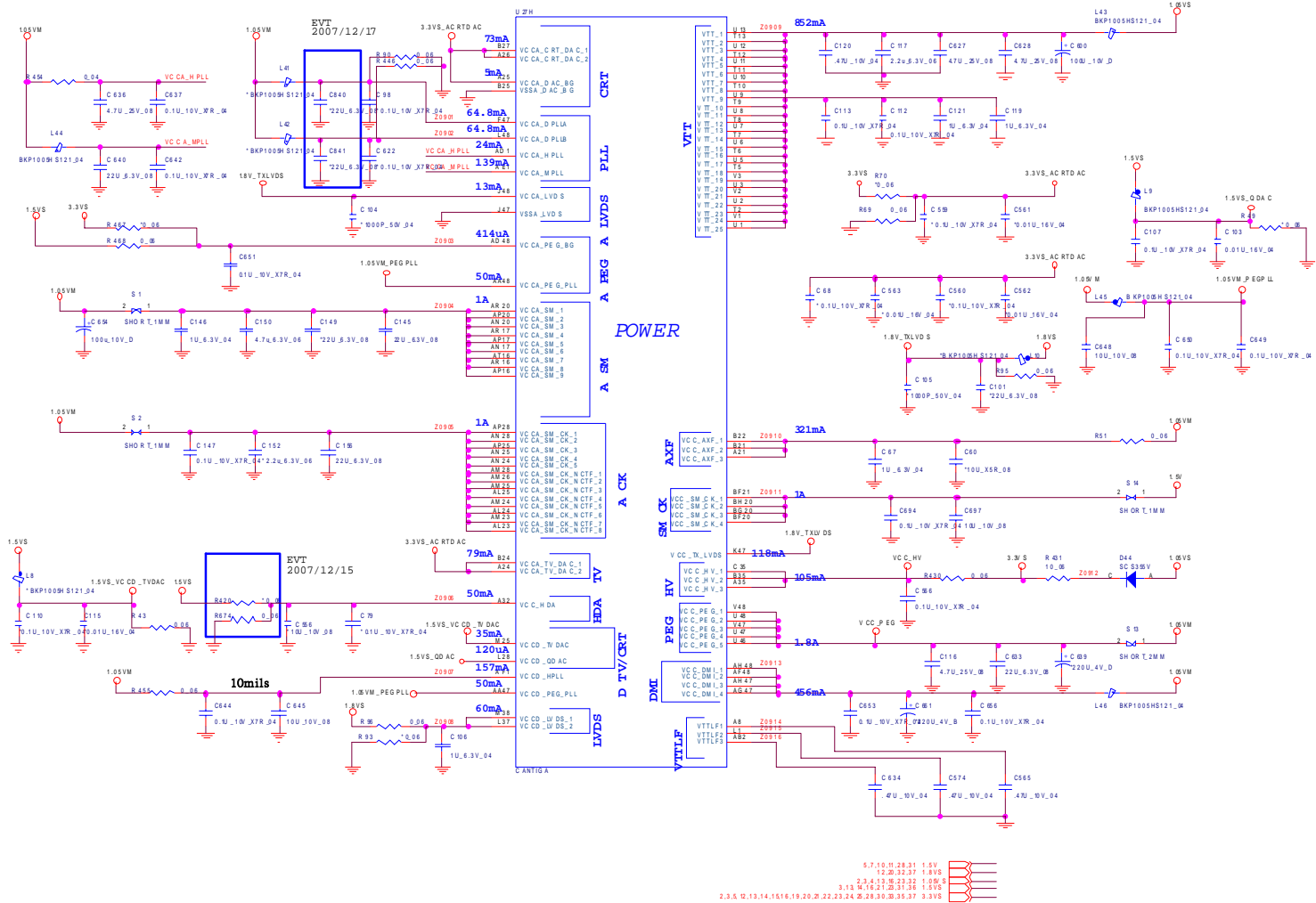

DDR3 SO-DIMM 0

SO-DIMM 0

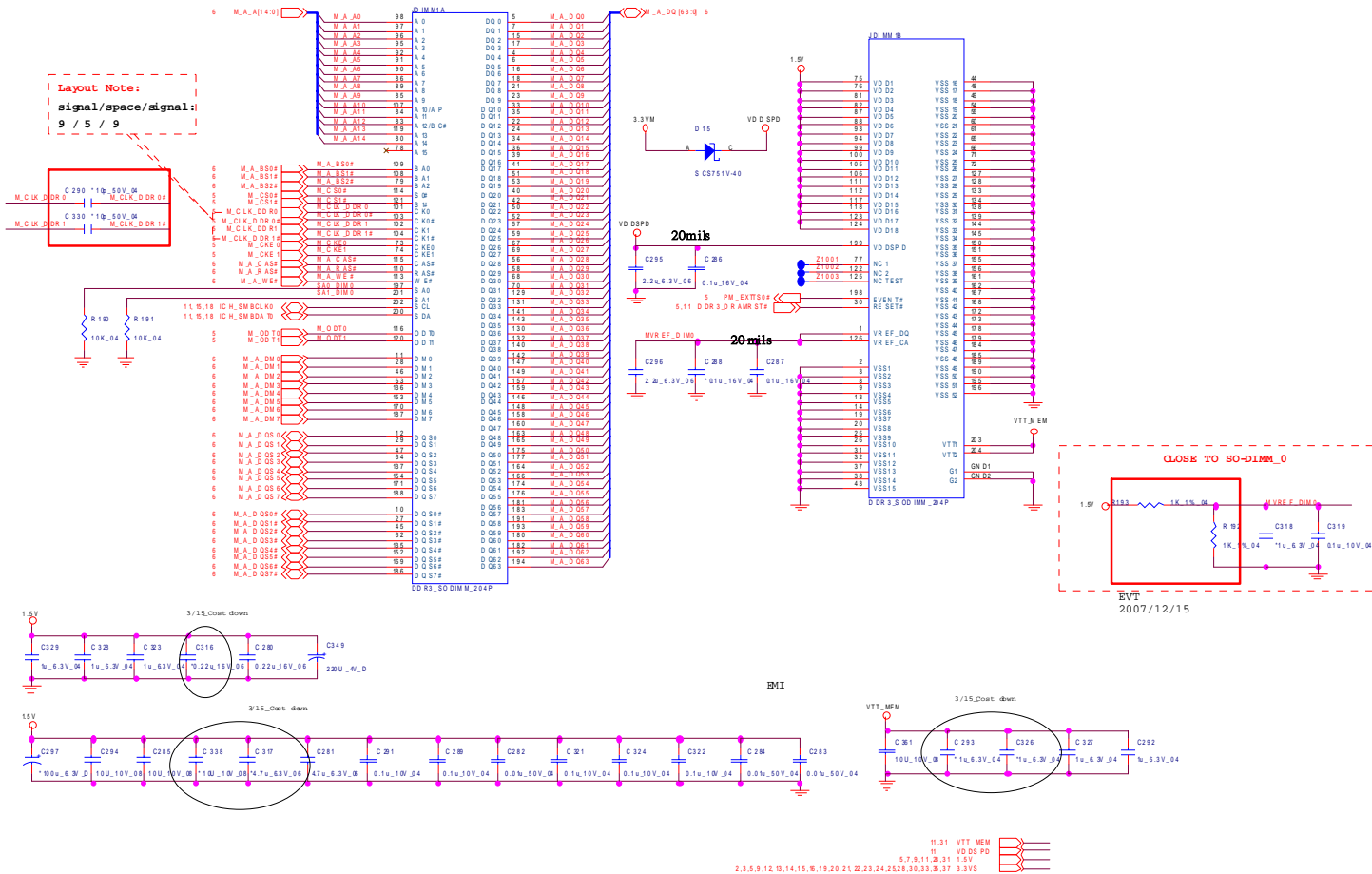

Sheet 10 of 42
 DDR3 SO-DIMM 0

DDR3 SO-DIMM 1

SO-DIMM 1

B.Schematic Diagrams

Sheet 11 of 42
DDR3 SO-DIMM 1

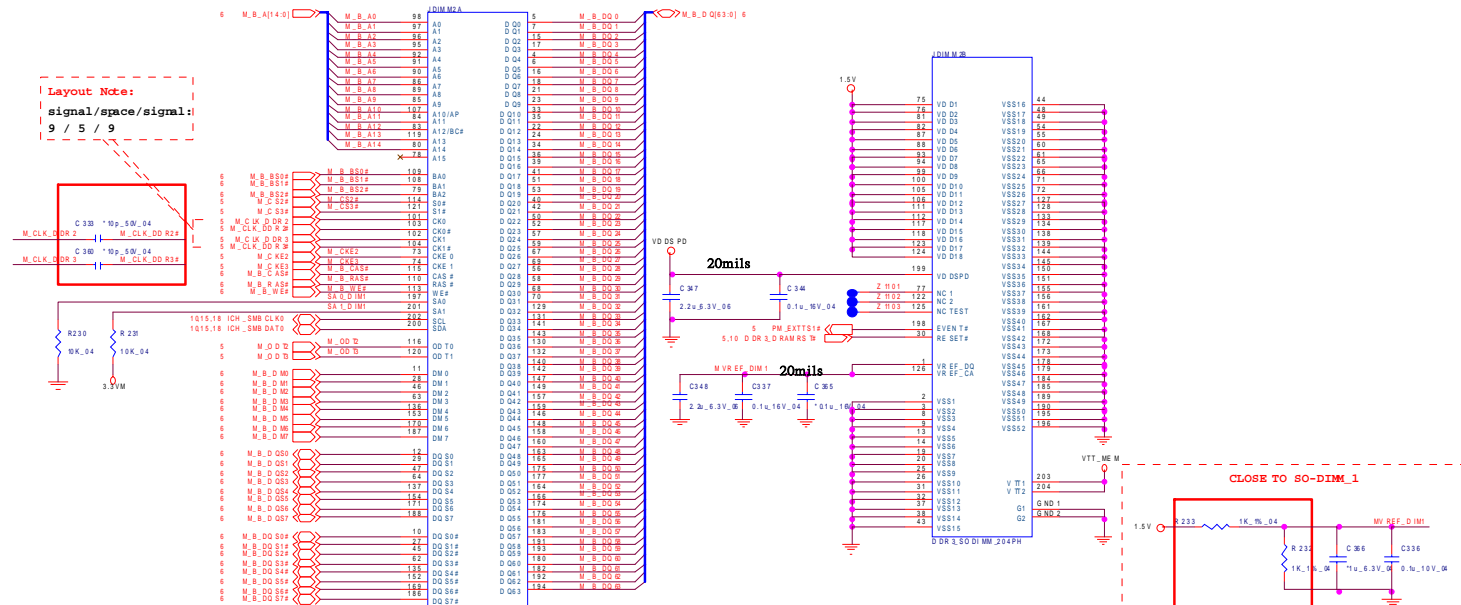

Layout note:
SO-DIMM 1 is placed farther from the GMCH than SO-DIMM 0

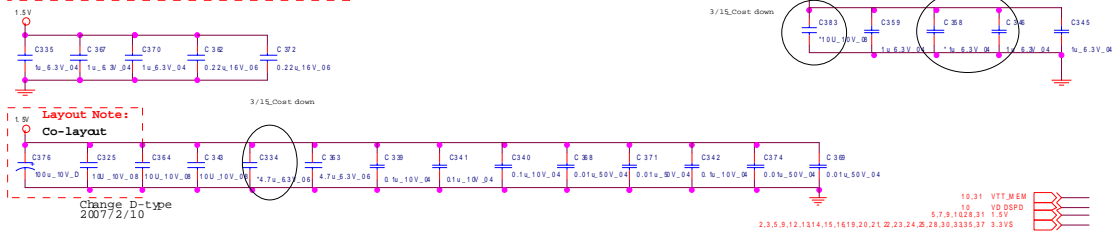

EVT 2007/12/15

LCD,CPU FAN

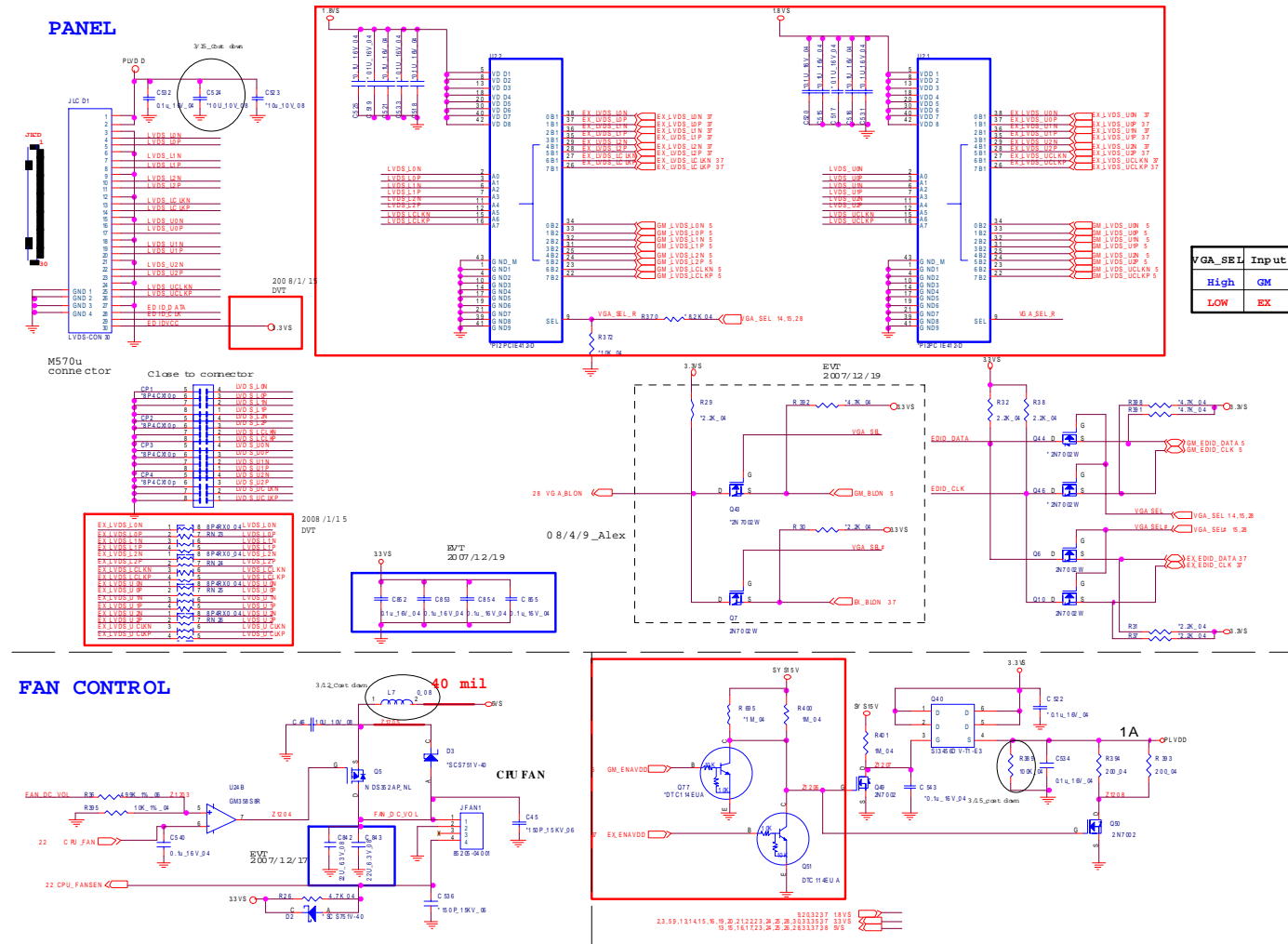

B. Schematic Diagrams

Sheet 12 of 42
LCD,CPU FAN

ICH9-M 2/4 PCI,USB

ICH9M Boot BIOS select				
	Strap	PCI_CN TR0	SPI_CS#1	
FWH(default)	11	R529 unstuff	R478 unstuff	
PCI	10	R529 unstuff	R478 unstuff	
SPI	01	R529 stuff	R478 unstuff	

SPI_CS#1 have internal pull up.

PCIRST#: LAN, Cardbus, KBC
 PLT_RST#: N/B, IDE, FWH, MXX
 BUF_PLT_RST#: NEW CARD, MINI CARD-1/2, MINI PCI

SPI_S1	1TPM Enable
Stuffed	Enable
NO_stuff	Disable

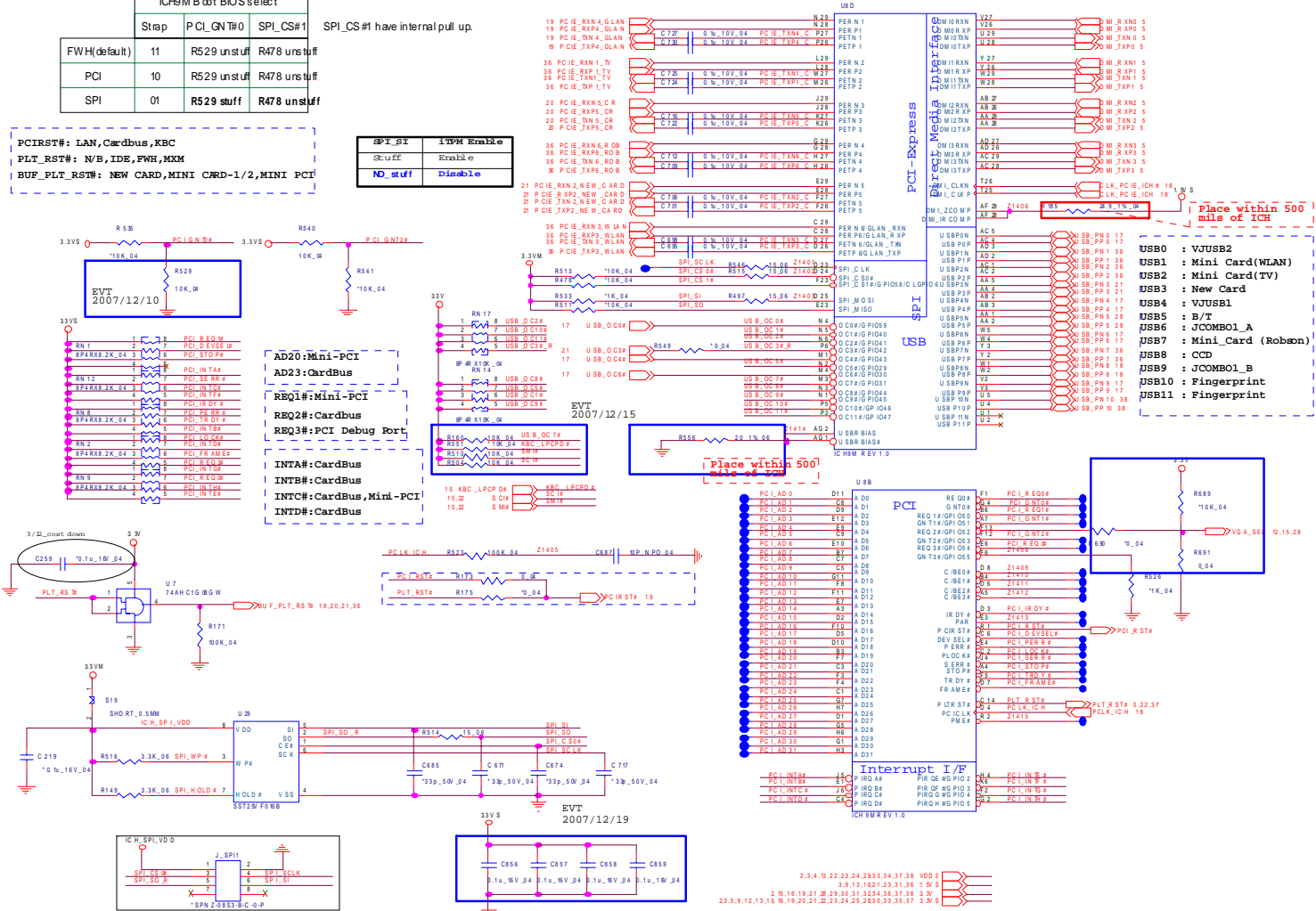

Sheet 14 of 42 ICH9-M 2/4 PCI,USB

B. Schematic Diagrams

ICH9-M 3/4 CASE FAN

B.Schematic Diagrams

Sheet 15 of 42
ICH9-M 3/4 CASE FAN

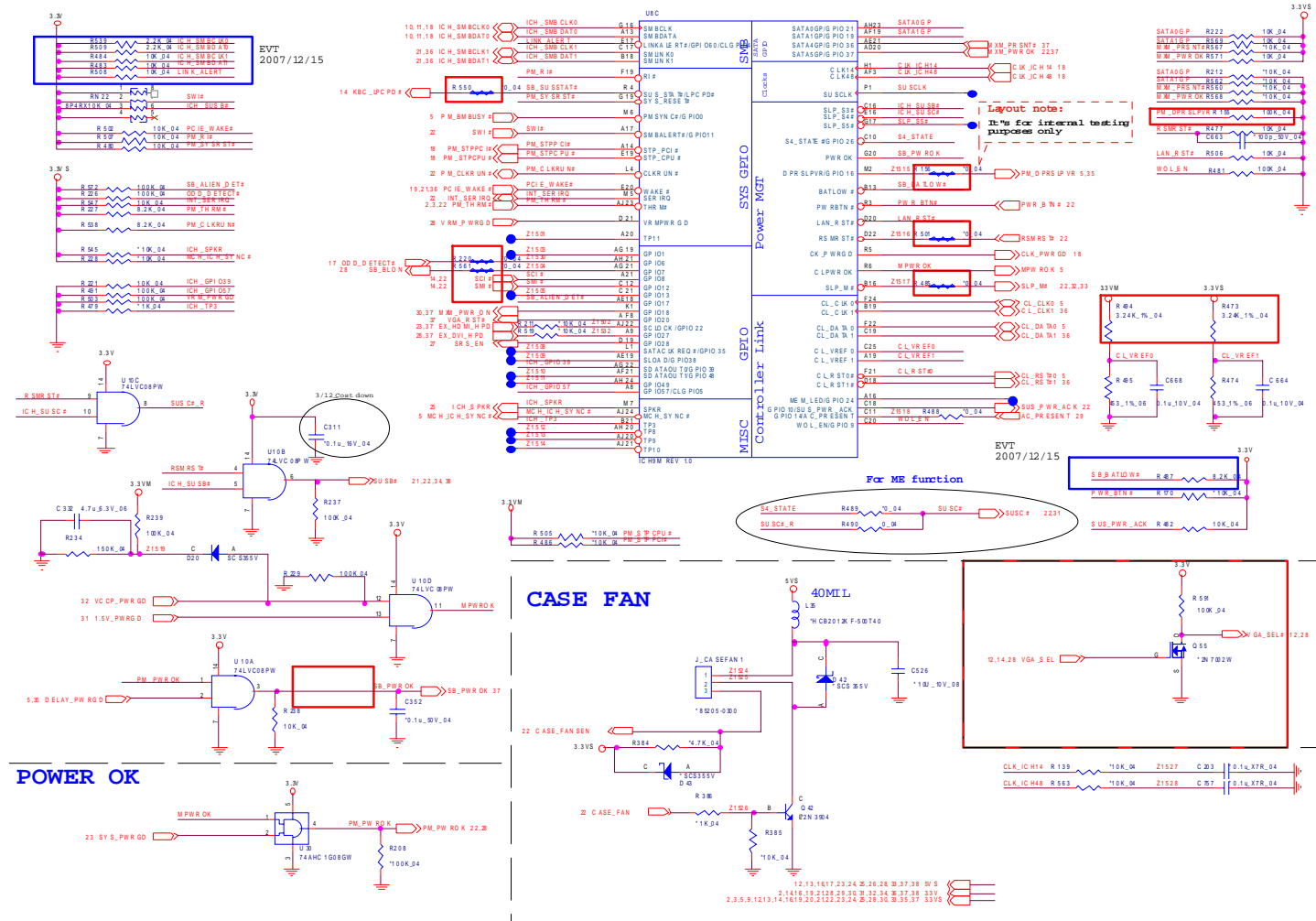

ODD, PC BEEP, USB2.0 & eSATA

Sheet 17 of 42
ODD, PC BEEP,
USB2.0 & eSATA

B.Schematic Diagrams

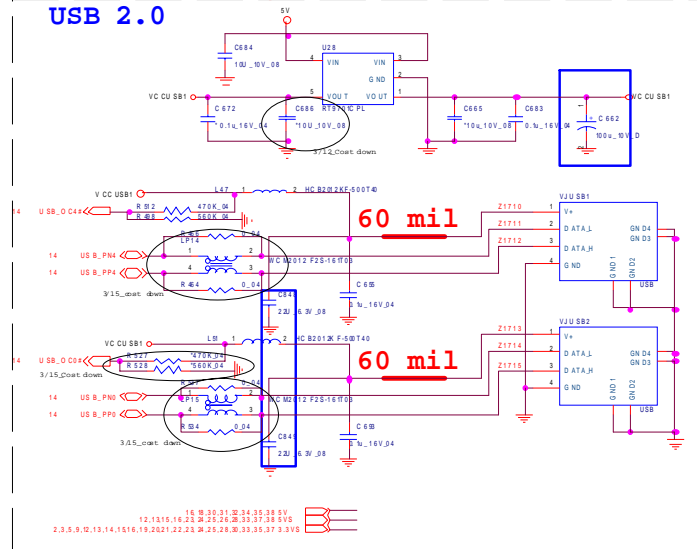
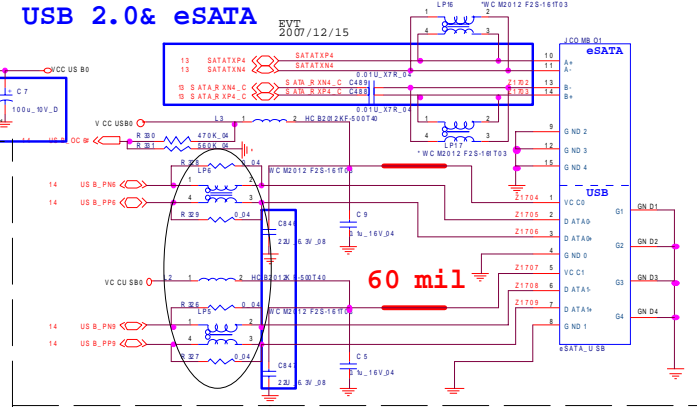
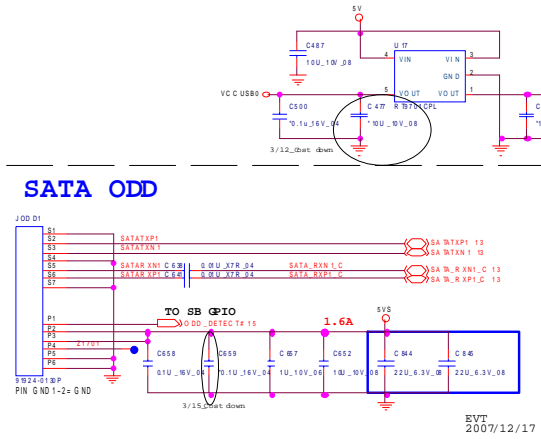

CLOCK GENERATOR, CCD

CLOCK GENERATOR

Layout note:
PLACE CRYSTAL WITHIN 500 MILS OF IC59LPR363

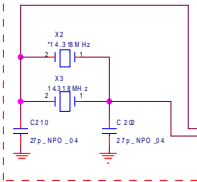

- SR C3 Card Reader (NO CR#)
- SR C4 Robson
- SR C5 TV
- SR C7 New Card
- SR C8 WLAN
- SR C9 GLAN
- SR C10 ICH (NO CR#)
- SR C12 MXM
- SR C13 MCH_PEG (NO CR#)

HOST2	HOST1	HOST0	Host Clock Frequency
0	0	1	53.3 Mhz
0	1	1	66.7 Mhz
0	1	0	80.0 Mhz
0	0	0	1.066 Mhz

40 mil

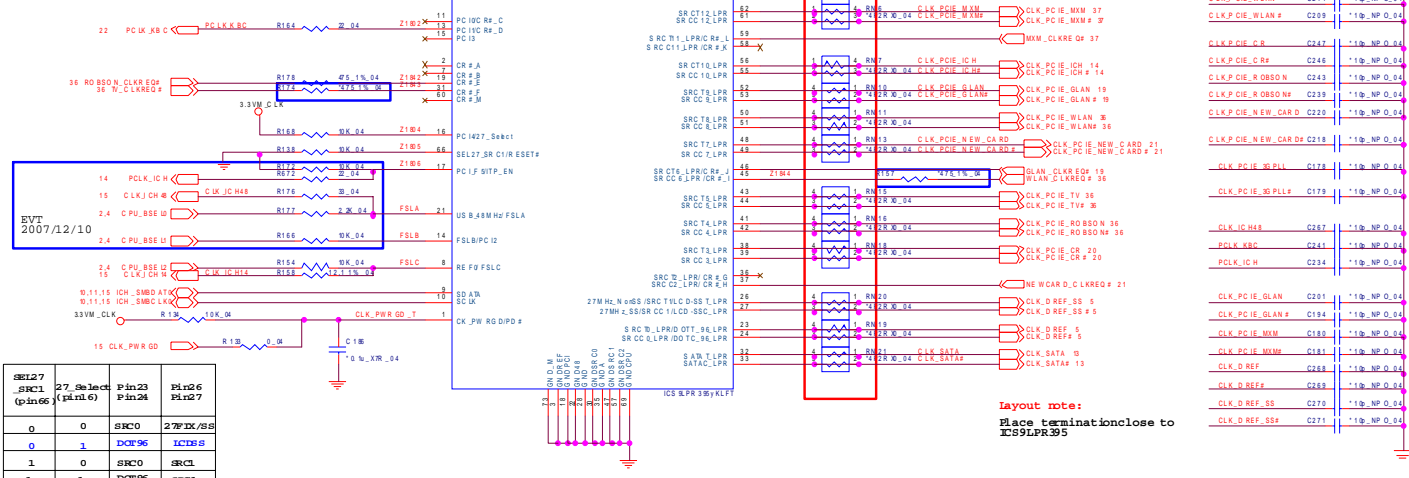

SEL27	SEL26	SEL25	SEL24	SEL23	SEL22
0	0	0	0	0	0
1	0	0	0	0	0
1	1	0	0	0	0

Layout note:
Place termination close to IC59LPR395

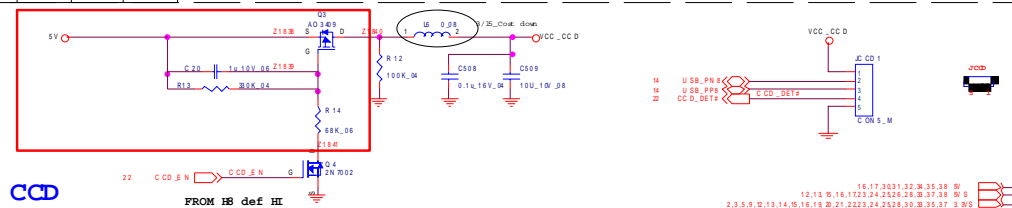

CCD

FROM IB def HI

Sheet 18 of 42
CLOCK GENERATOR, CCD

B. Schematic Diagrams

CARD READER & 1394 JMB380

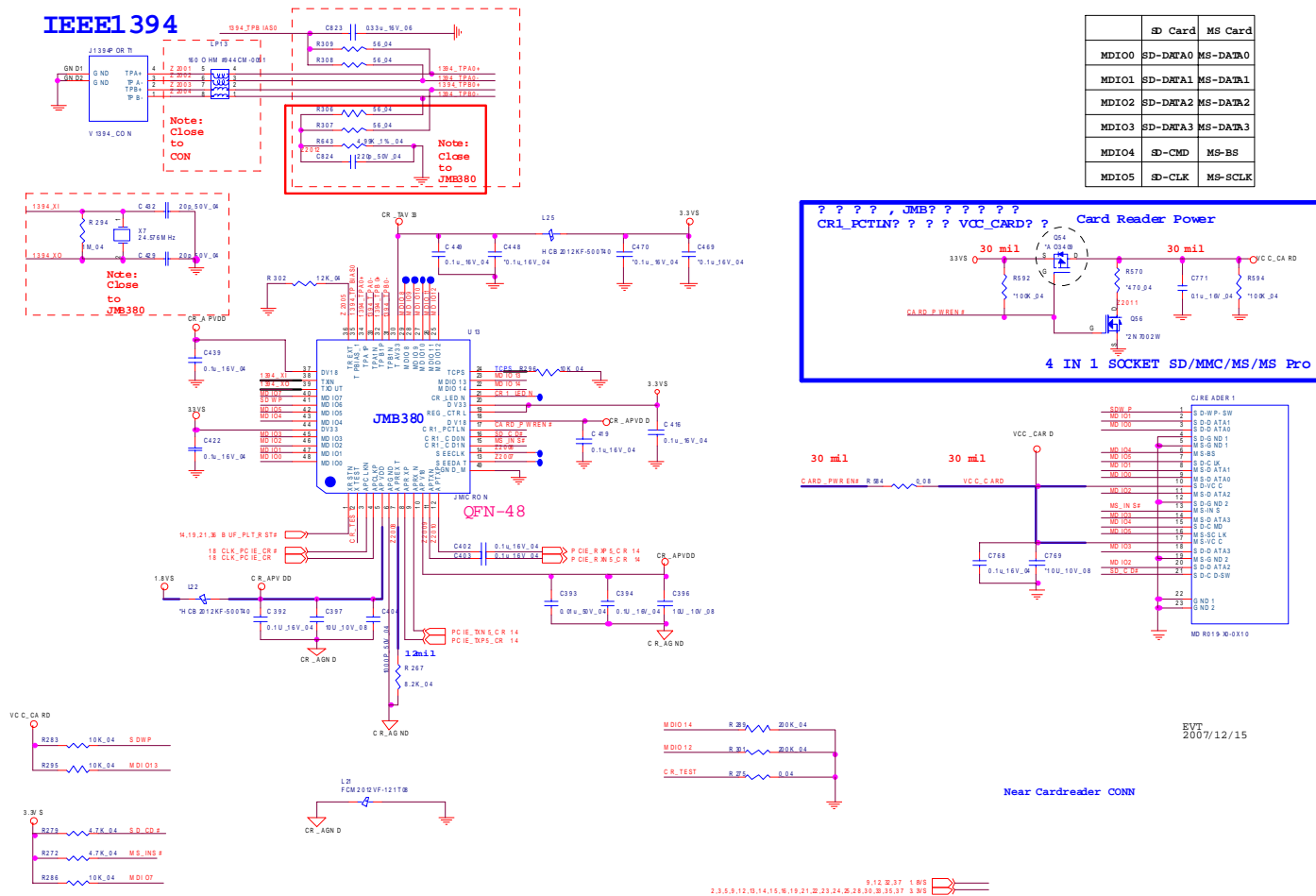

	SD Card	MS Card
MDI00	SD-DATA0	MS-DATA0
MDI01	SD-DATA1	MS-DATA1
MDI02	SD-DATA2	MS-DATA2
MDI03	SD-DATA3	MS-DATA3
MDI04	SD-CMD	MS-BS
MDI05	SD-CLK	MS-SCLK

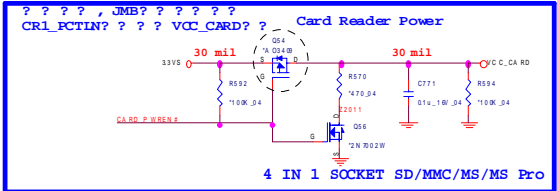

Sheet 20 of 42
CARD READER &
1394 JMB380

B.Schematic Diagrams

NEW CARD

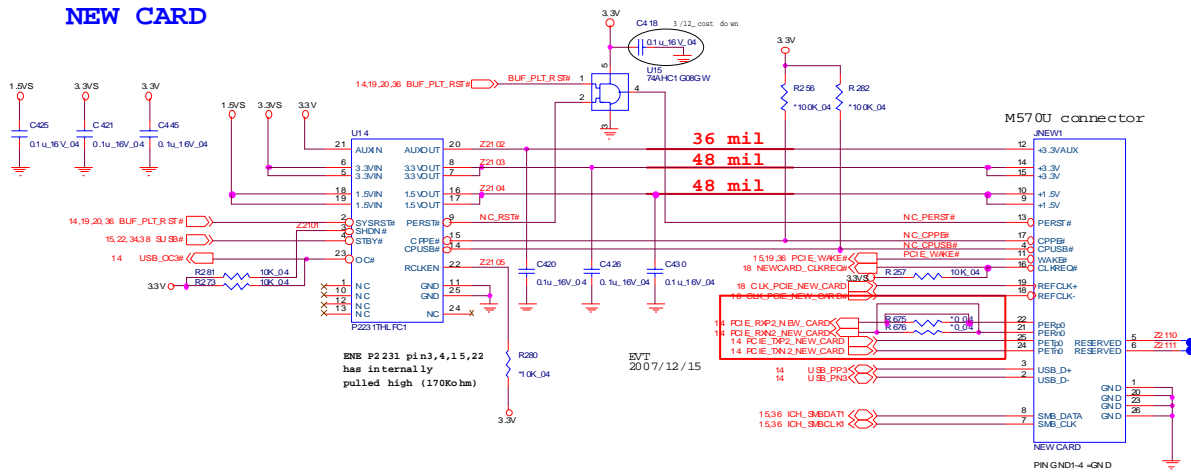

Sheet 21 of 42
NEW CARD

3,813,14,16,23,31,36 15V5
2,14,15,16,19,21,23,31,32,34,36,37,38 3.3V
2,3,5,8,1,2,13,14,15,16,18,20,22,2,3,2,26,28,30,33,35,37 3.3V5

KBC-ITE IT8512

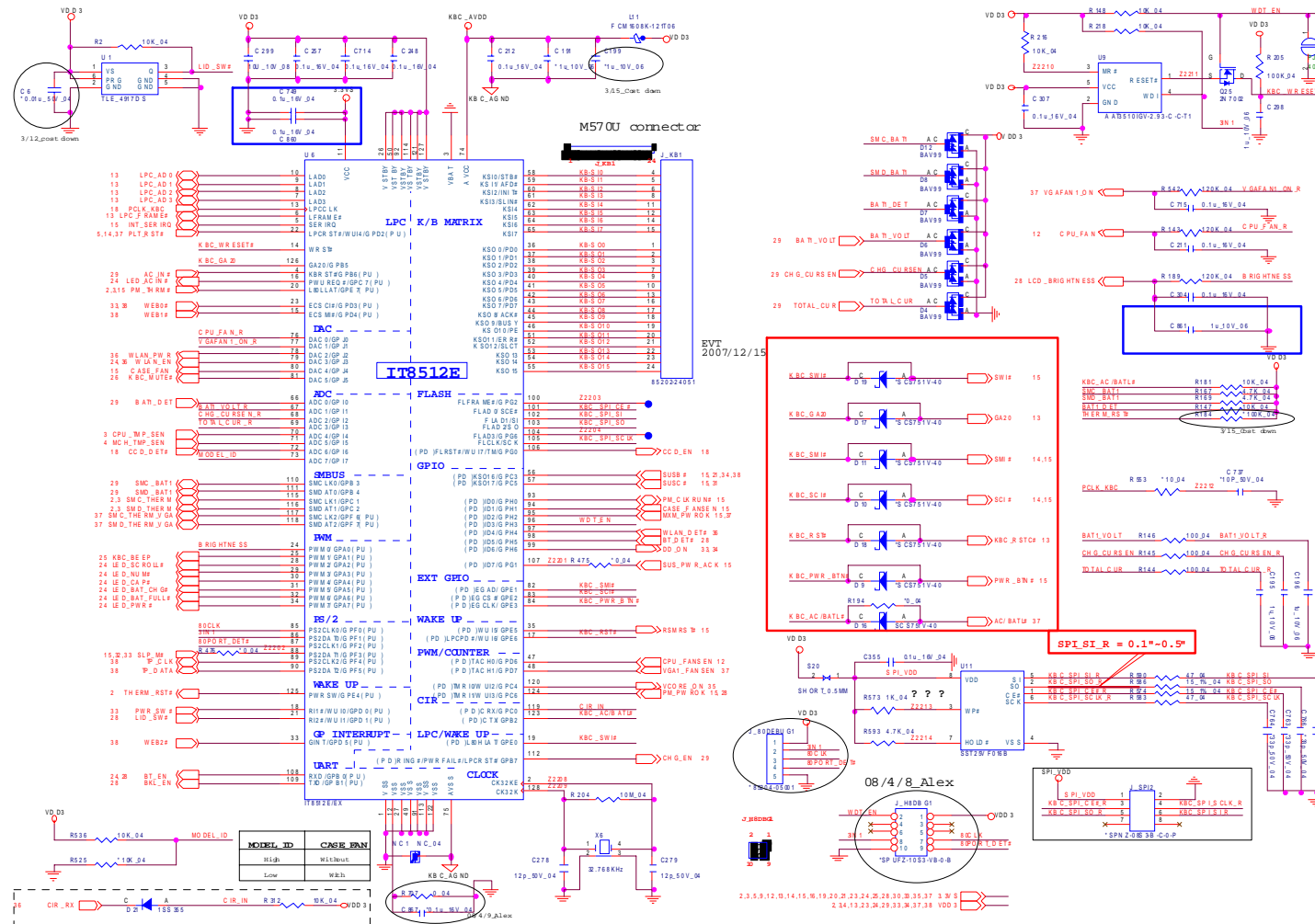

Sheet 22 of 42
KBC-ITE IT8512

B. Schematic Diagrams

Schematic Diagrams

HDMI

Sheet 23 of 42
HDMI

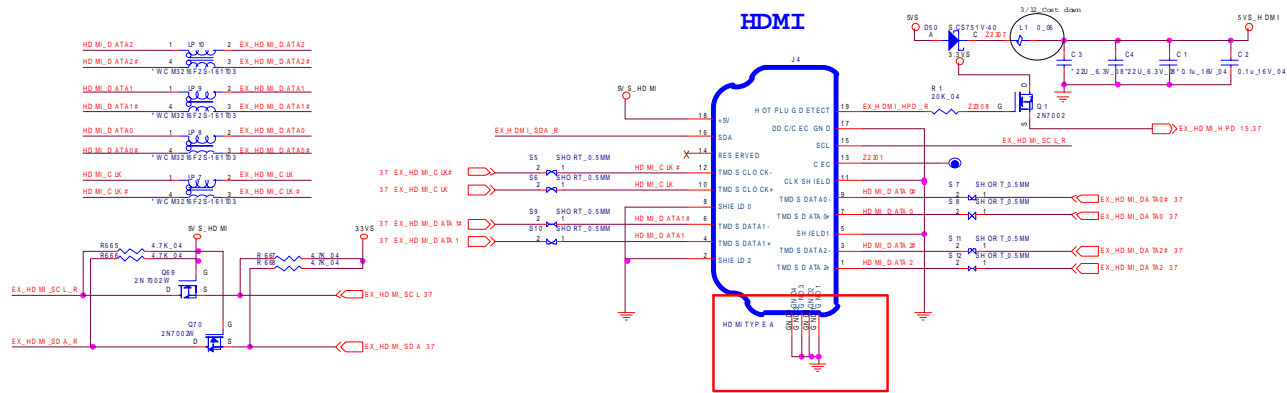

SYSTEM POWER OK

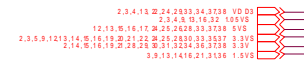
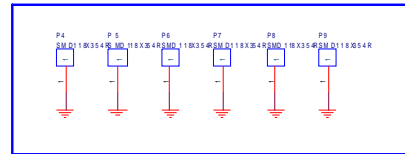
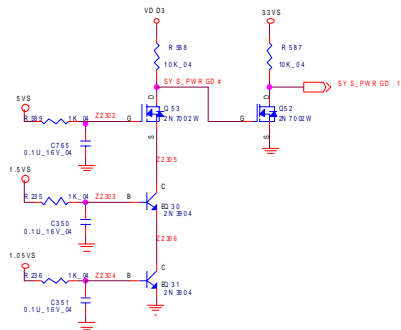

LED

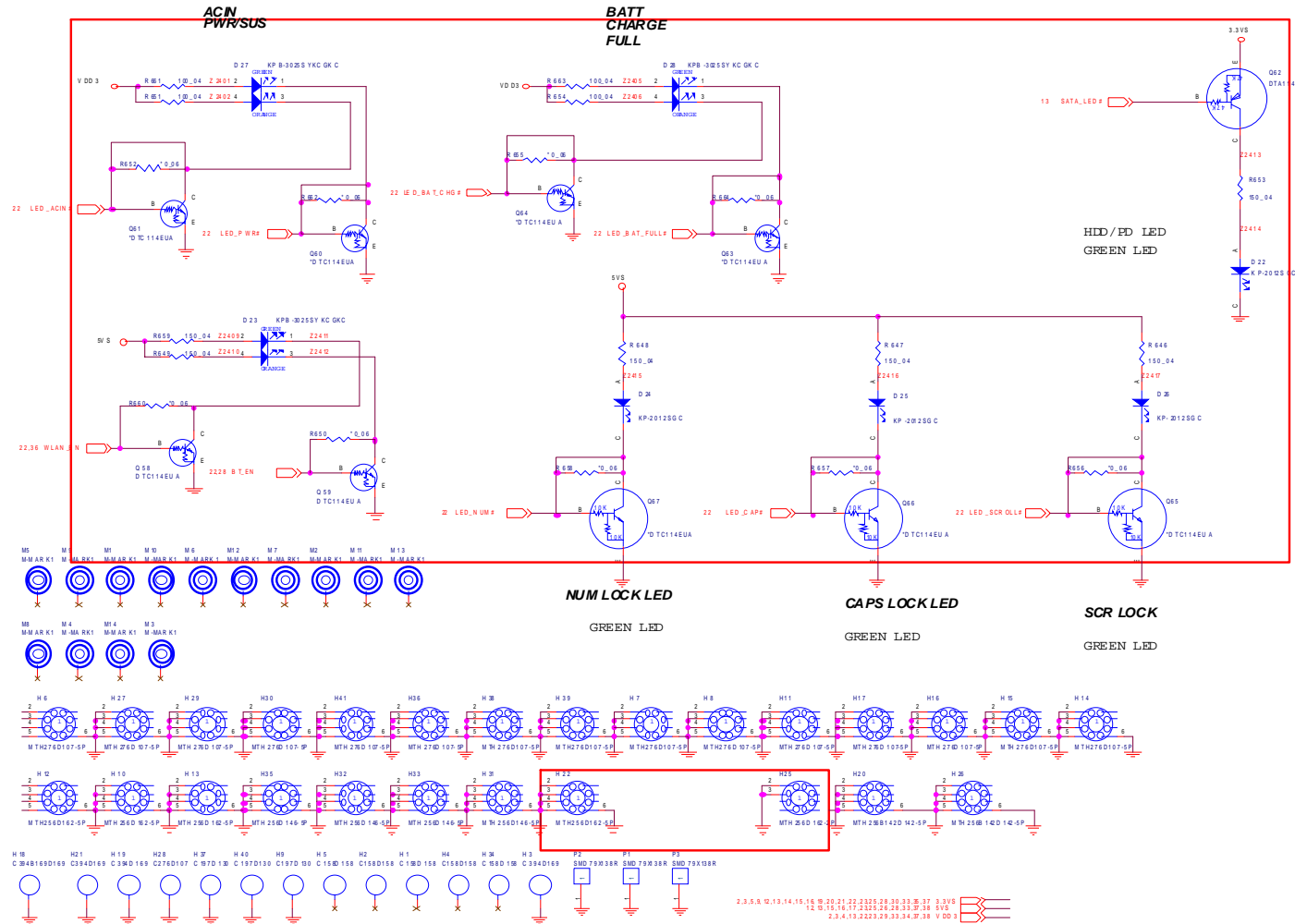

Sheet 24 of 42
LED

AZALIA CODEC ALC662

Sheet 25 of 42
AZALIA CODEC
ALC662

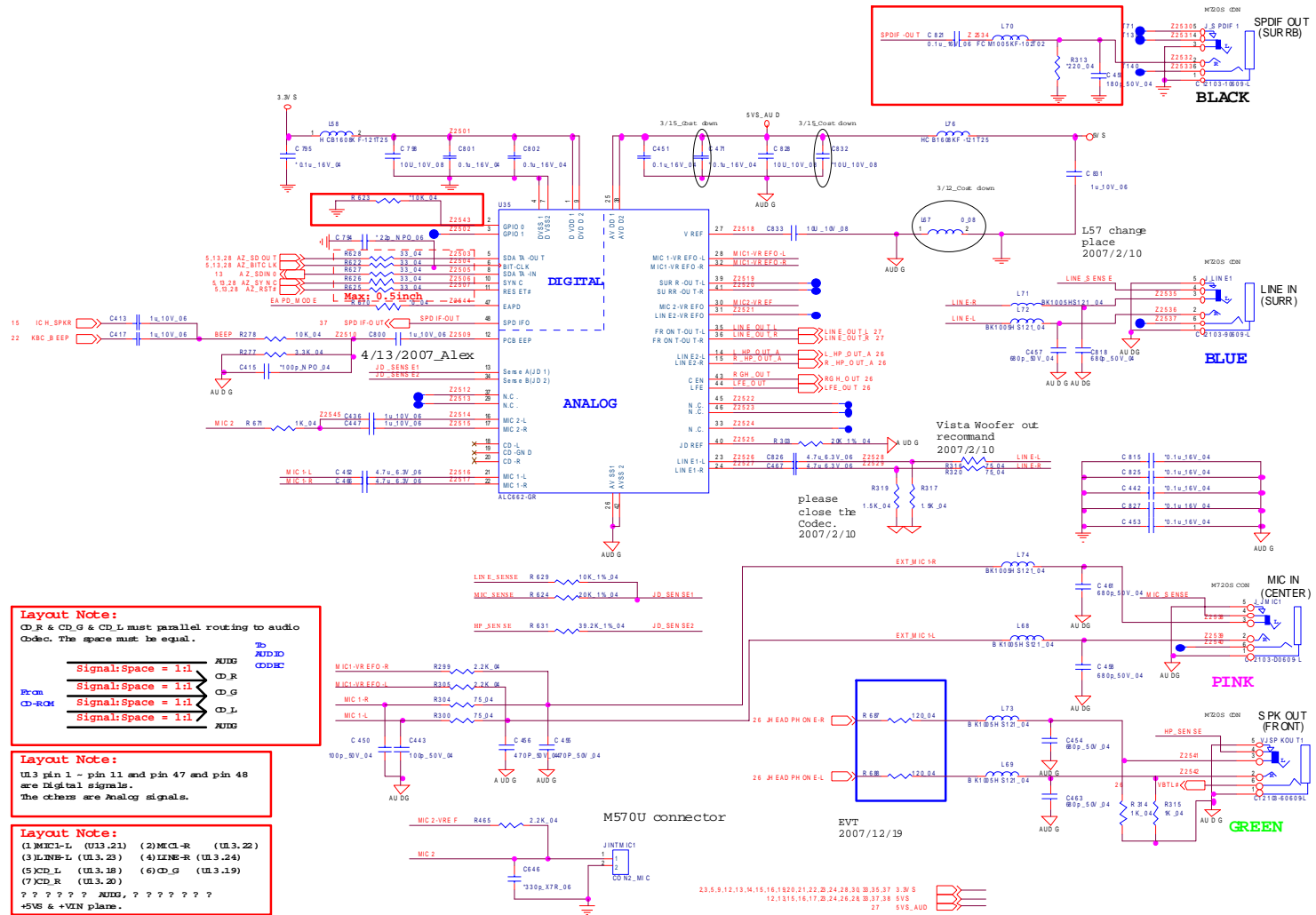

AUDIO AMP

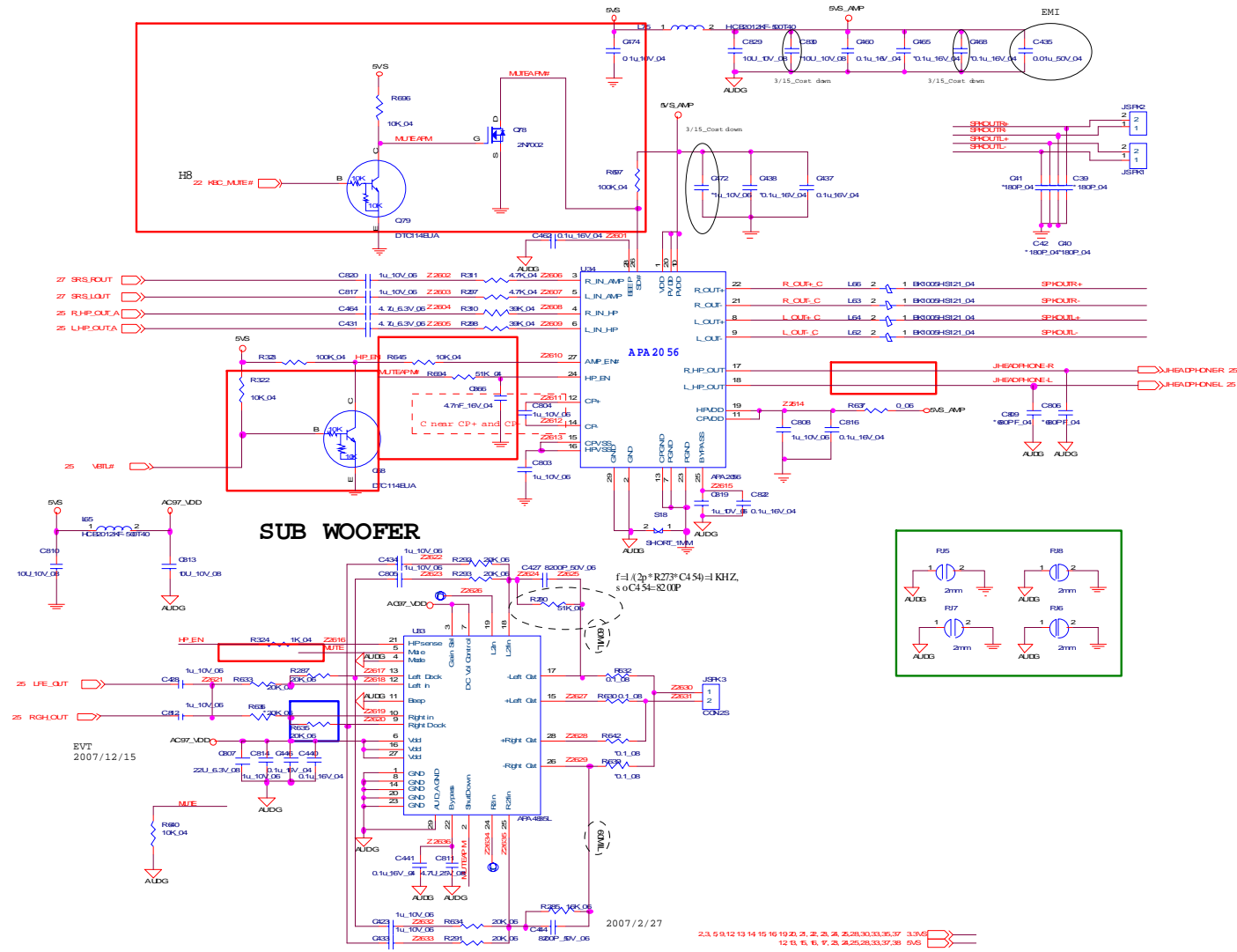

Sheet 26 of 42
AUDIO AMP

B. Schematic Diagrams

SRS

AUDIO PROCESSOR PRE-AMP

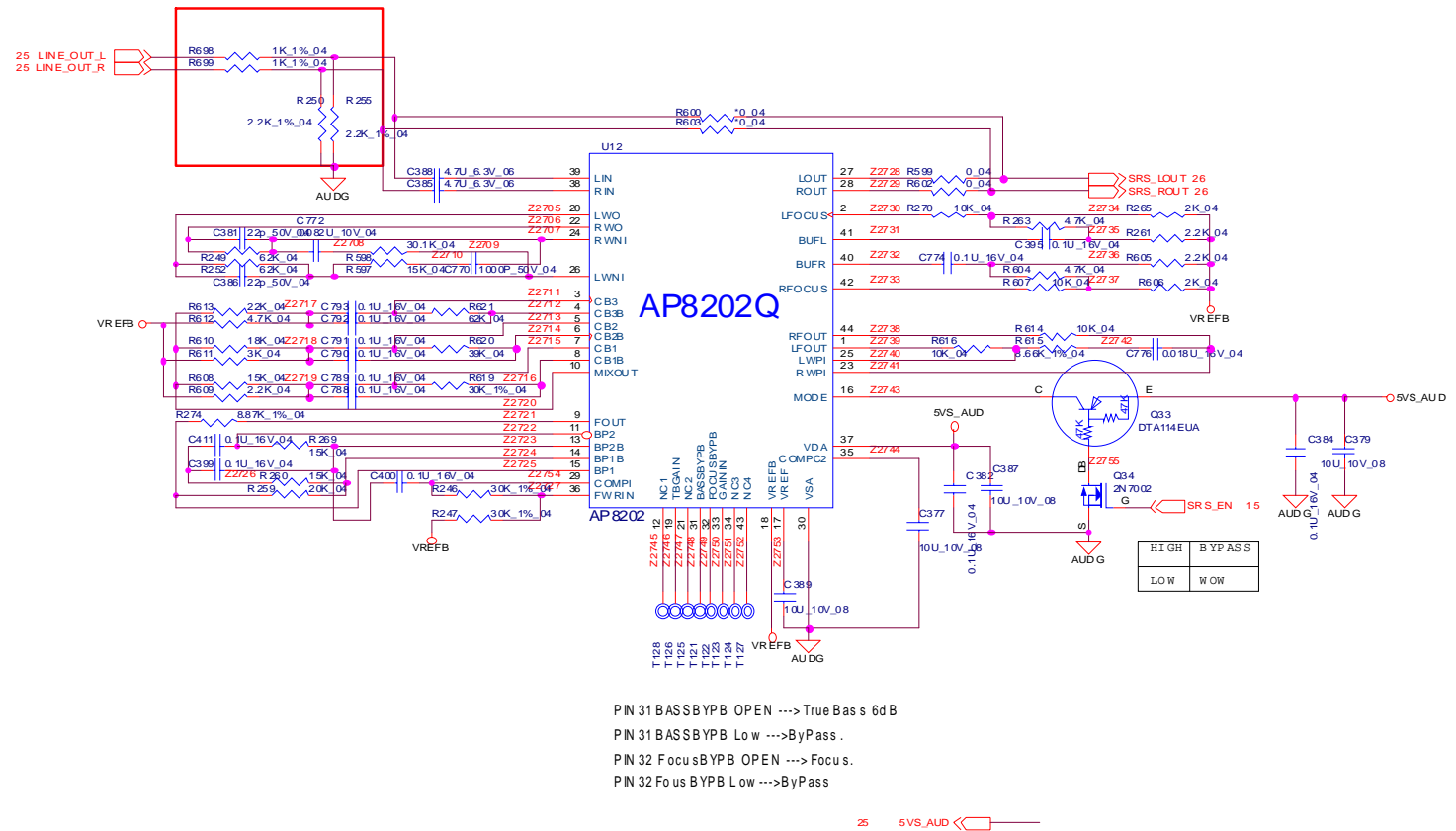

Sheet 27 of 42
SRS

B.Schematic Diagrams

CRT, INV, MDC, BT, PWRGD

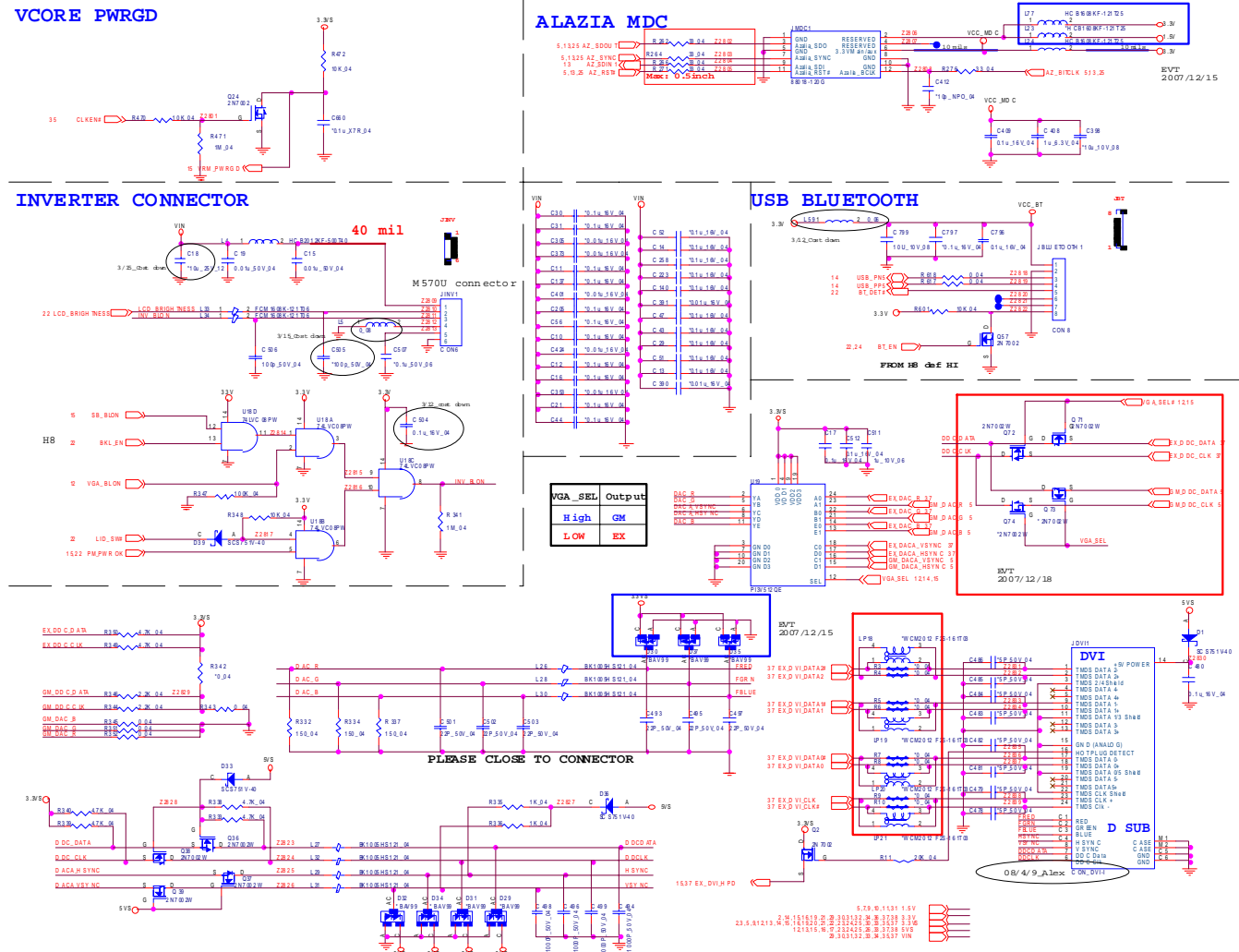

Sheet 28 of 42
 CRT, INV, MDC, BT,
 PWRGD

B. Schematic Diagrams

Schematic Diagrams

Power Charger, DC IN

B.Schematic Diagrams

Sheet 29 of 42
Power Charger, DC IN

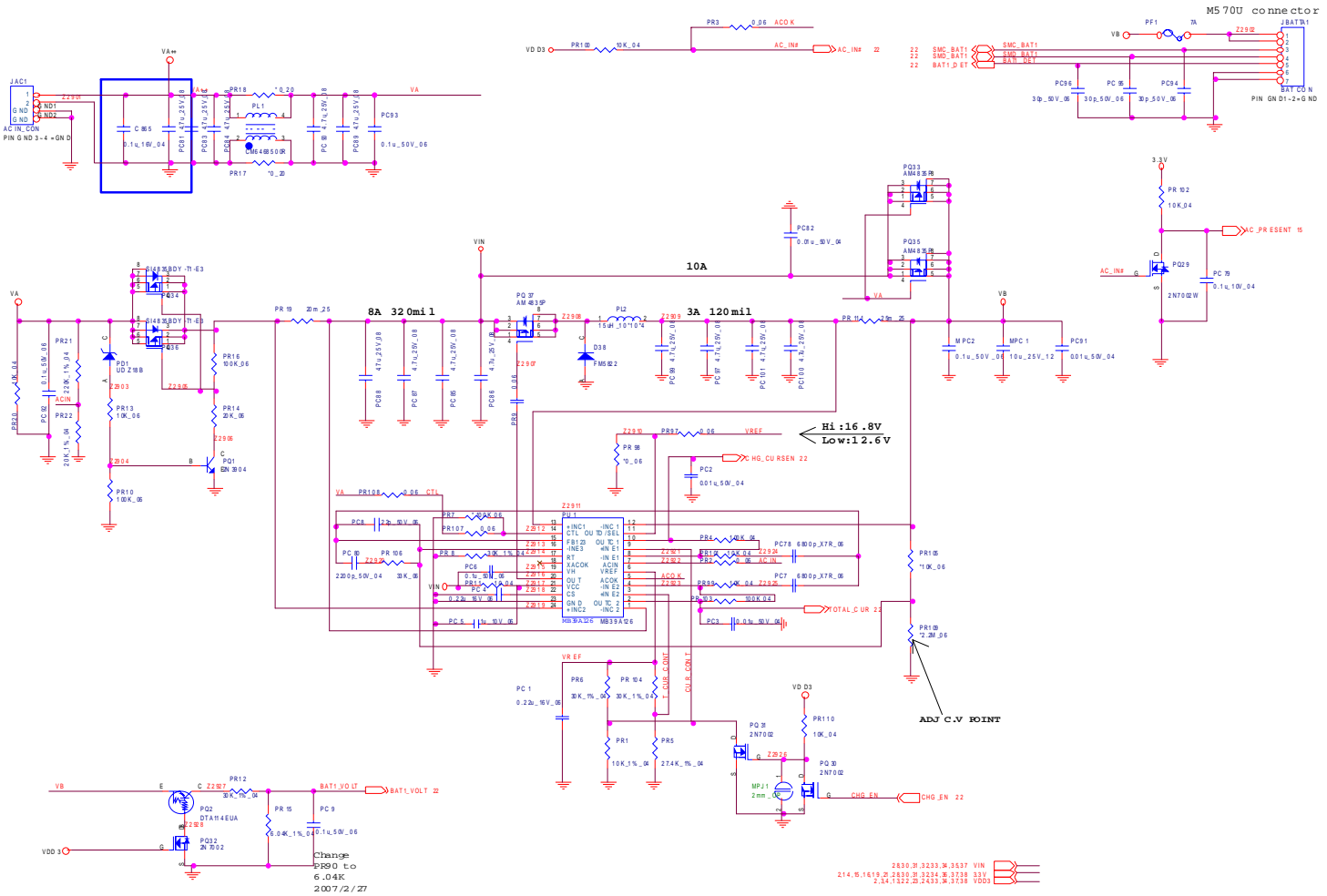

Power GPU

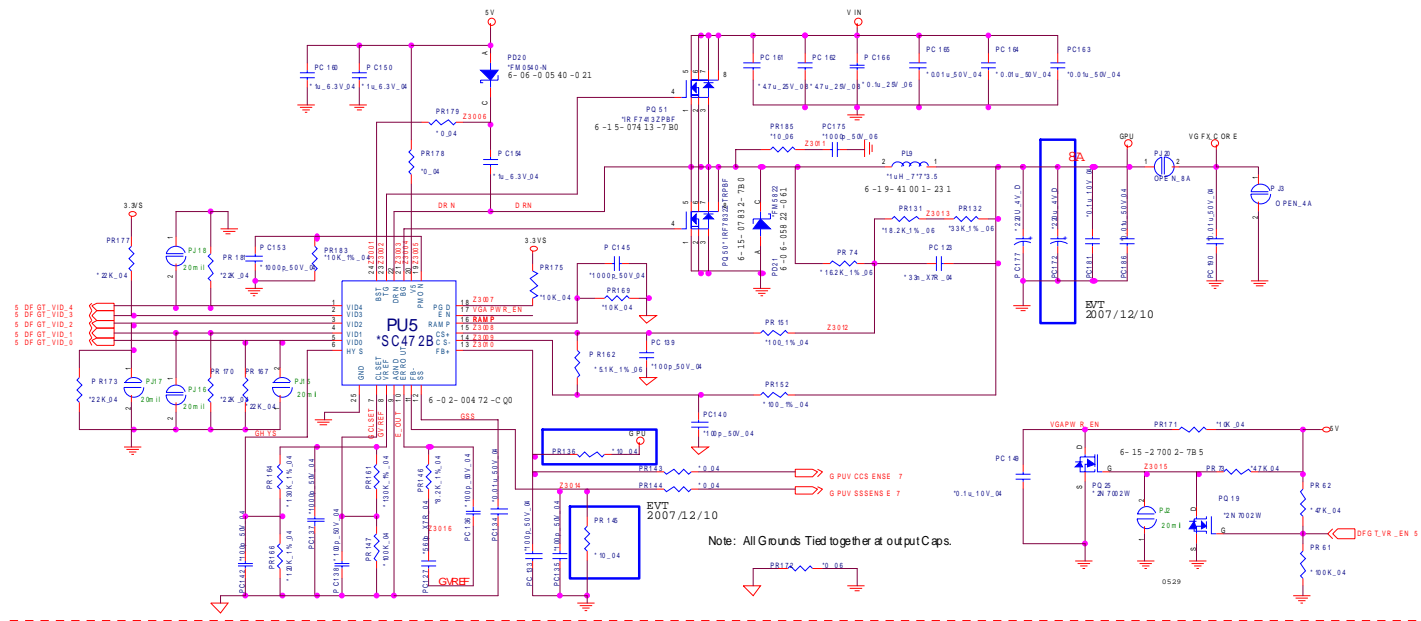

Sheet 30 of 42
Power GPU

B. Schematic Diagrams

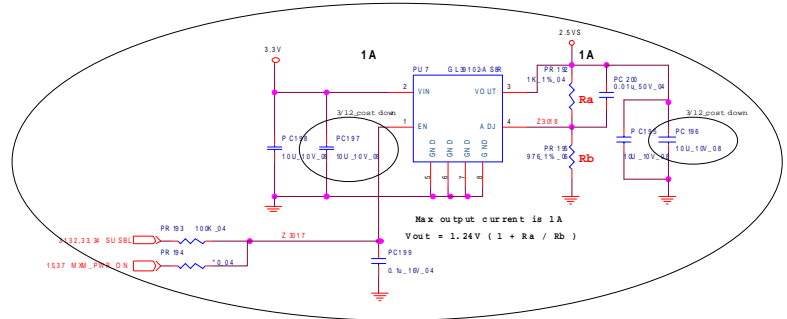

Max output current is 1A
 $V_{out} = 1.24V (1 + R_a / R_b)$

- 2,14,15,16,18,21,28,31,33,34,36,37,38 33V
- 16,17,18,33,32,34,35,38 5V
- 37 25V
- 2,5,6,9,12,13,14,15,16,19,20,21,22,23,24,25,28,33,35,37 33V
- 28 25V
- 31,32,35,36,37 33V
- 31,32,35,36,37 33V

Schematic Diagrams

Power 1.5V/ 0.75V

B.Schematic Diagrams

Sheet 31 of 42
Power 1.5V/ 0.75V

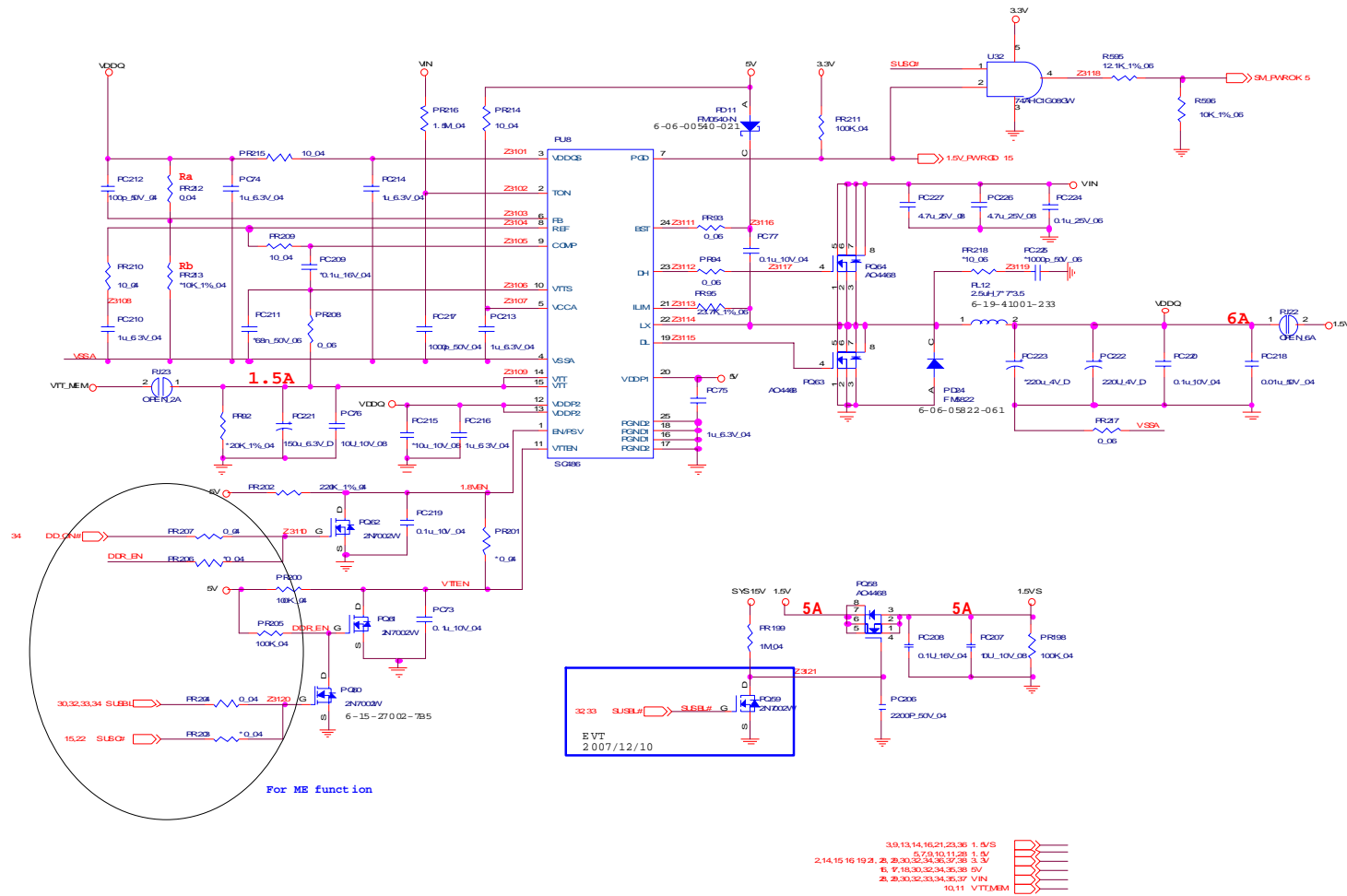

Power 1.8VS/ 1.05VS

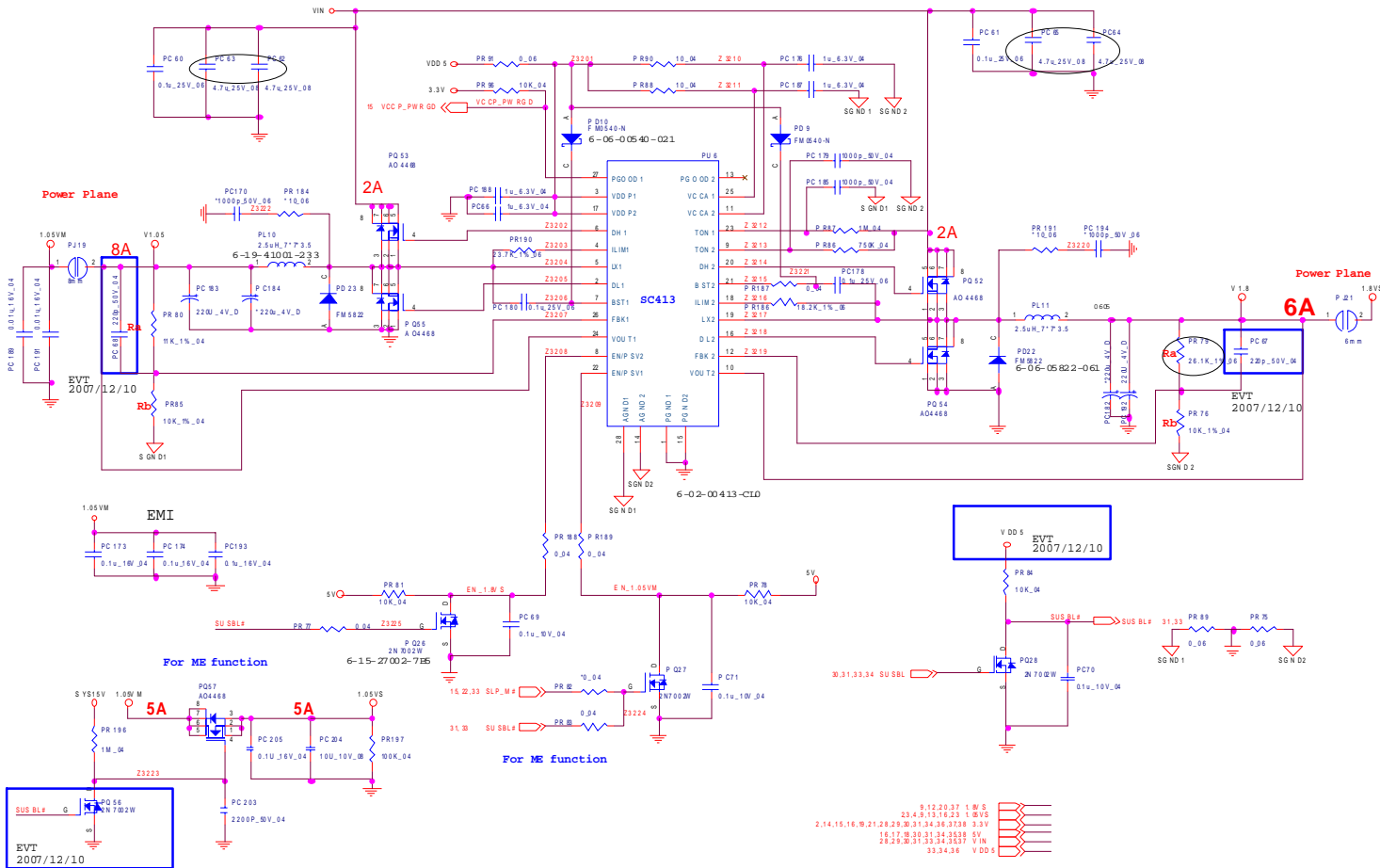

Sheet 32 of 42
Power 1.8VS/ 1.05VS

B. Schematic Diagrams

Schematic Diagrams

Power 3VS, 5VS, Power S/W

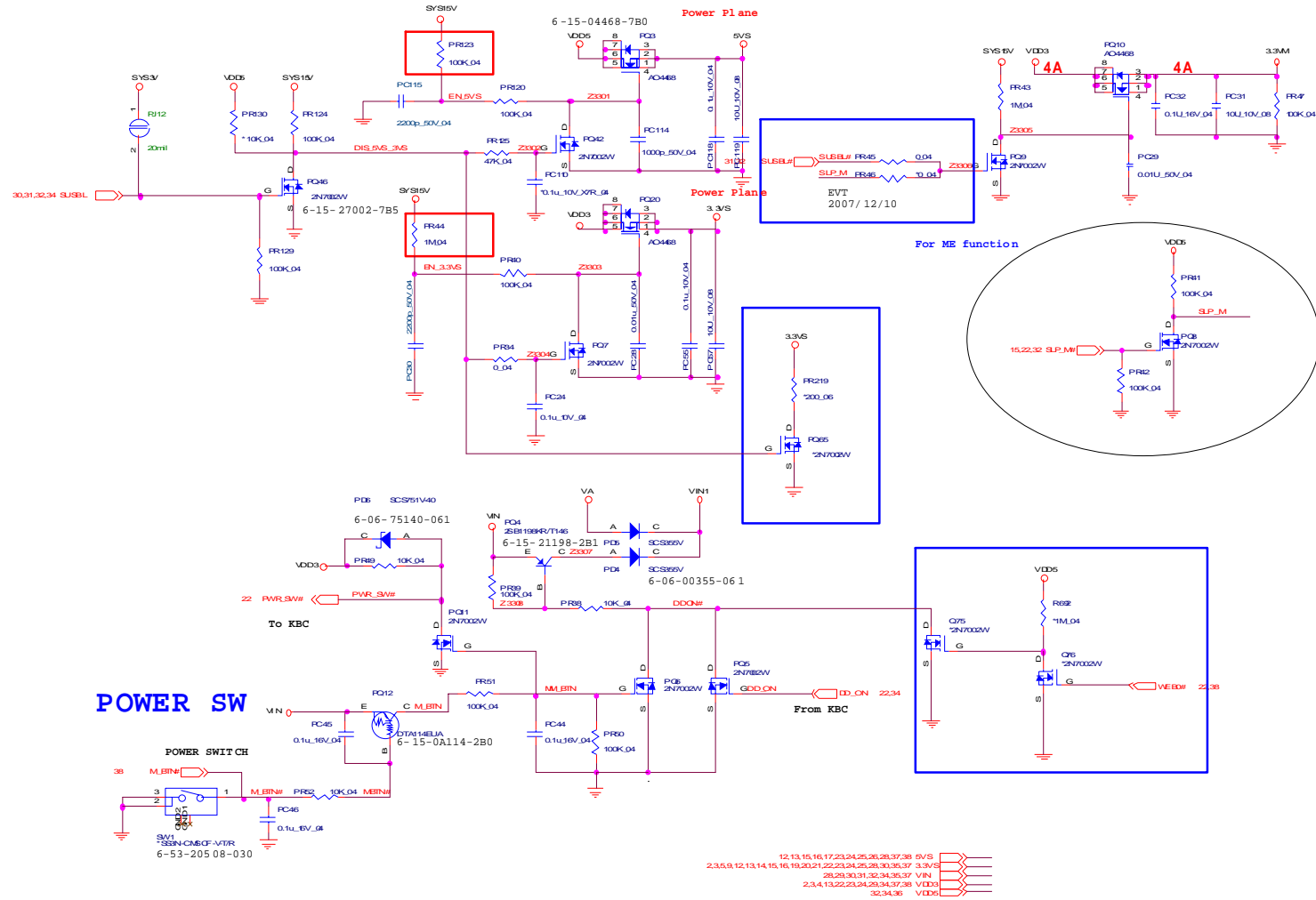

Sheet 33 of 42
Power 3VS, 5VS,
Power S/W

B.Schematic Diagrams

Power VDD3/ VDD5/ 3.3V/ 5V

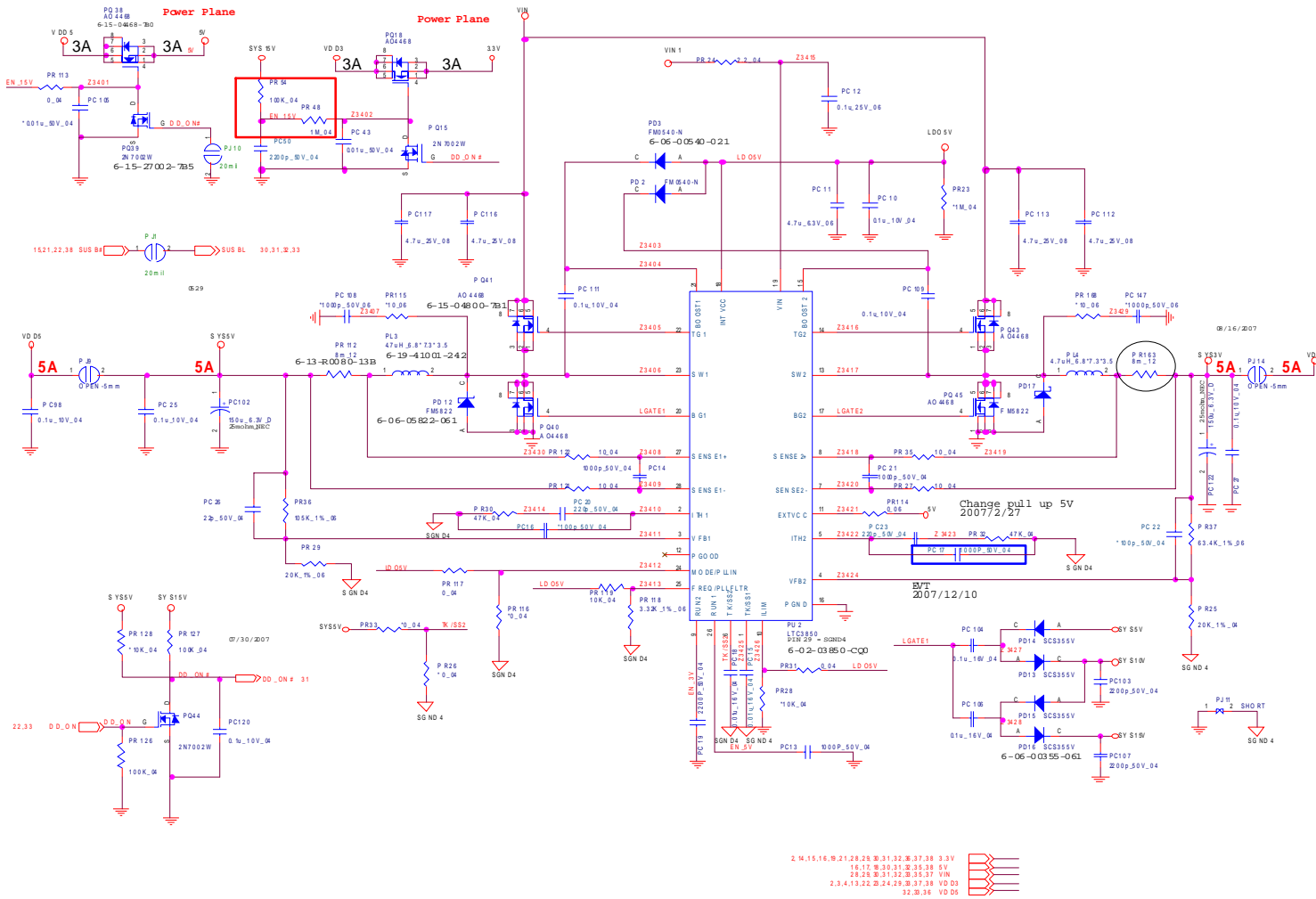

Sheet 34 of 42
Power VDD3/
VDD5/ 3.3V/ 5V

B. Schematic Diagrams

Power VCORE for Penryn CPU

Sheet 35 of 42
Power VCORE for
Penryn CPU

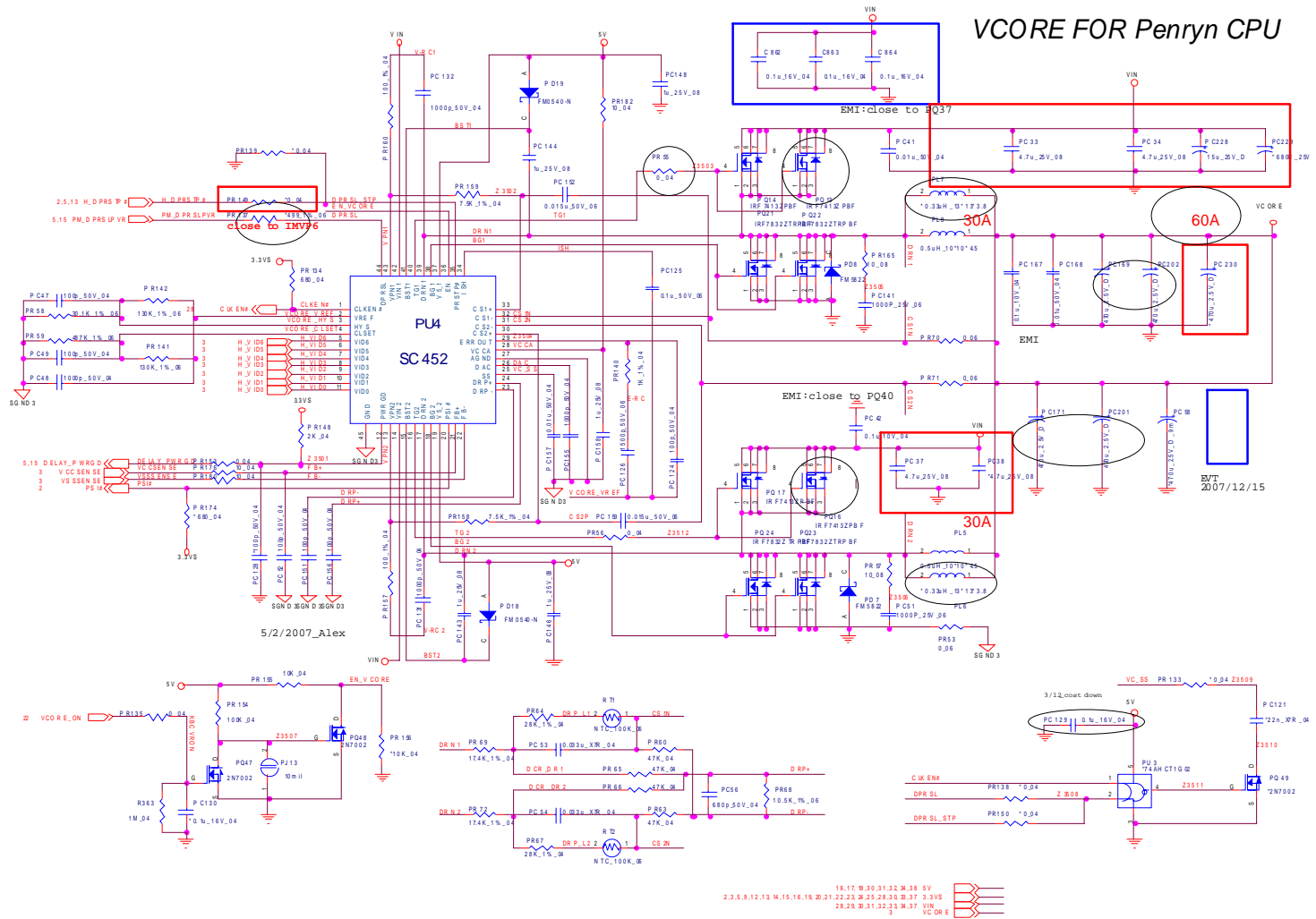

MINI CARD, CIR

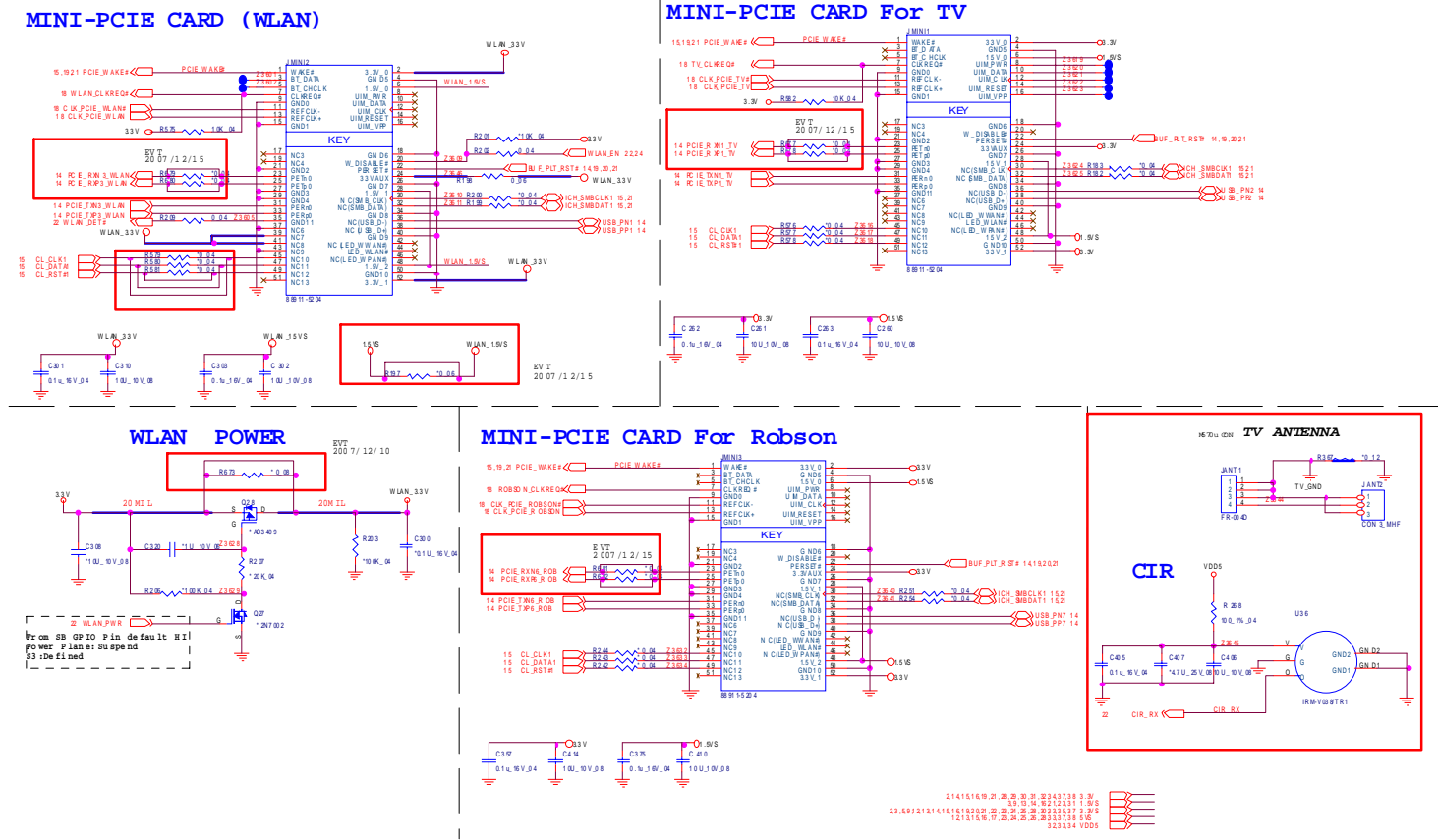

Sheet 36 of 42
MINI CARD, CIR

B. Schematic Diagrams

MXM PCI-E TYPE-IV

Sheet 37 of 42
MXM PCI-E TYPE-IV

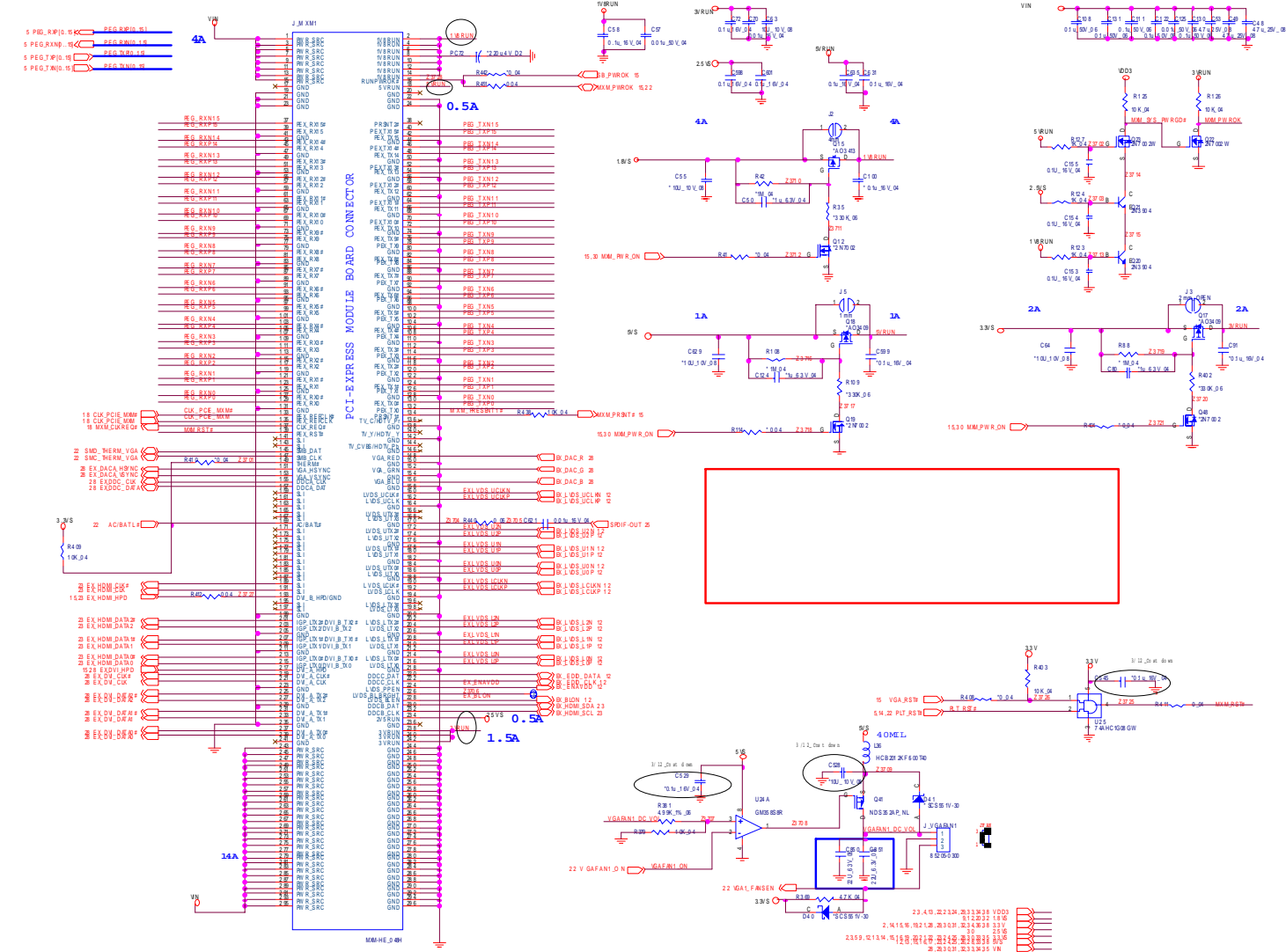

Board to board CON

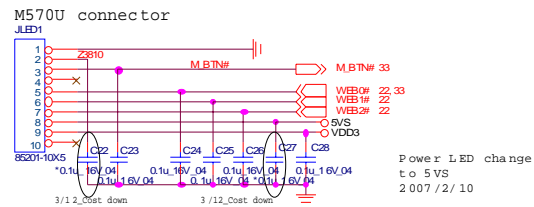

HOT KEY (M/B side)

CLICK(M/B side)

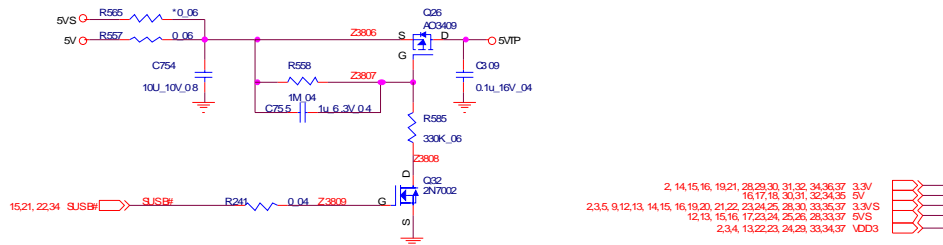
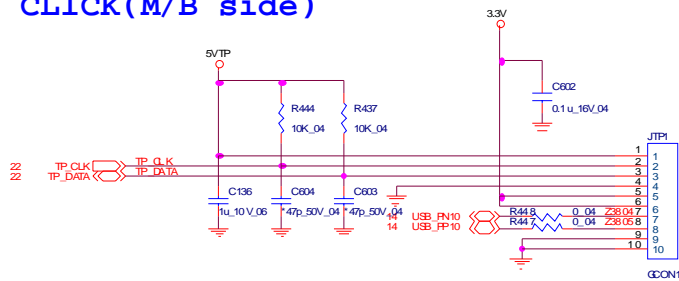

Sheet 38 of 42
Board to board
CON

BUTTON BOARD

Sheet 39 of 42
BUTTON BOARD

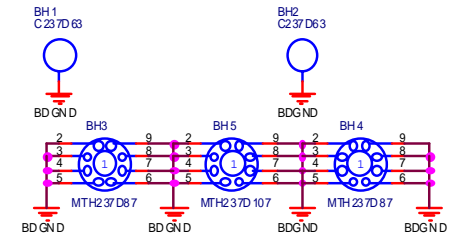
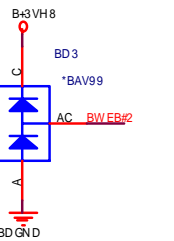
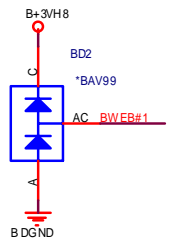
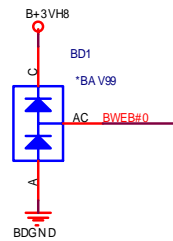
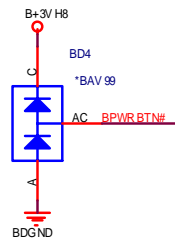
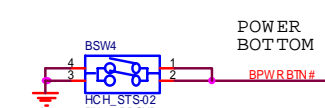
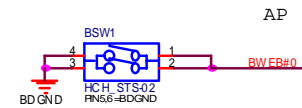
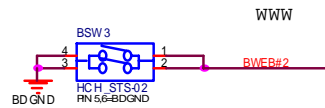
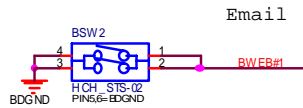
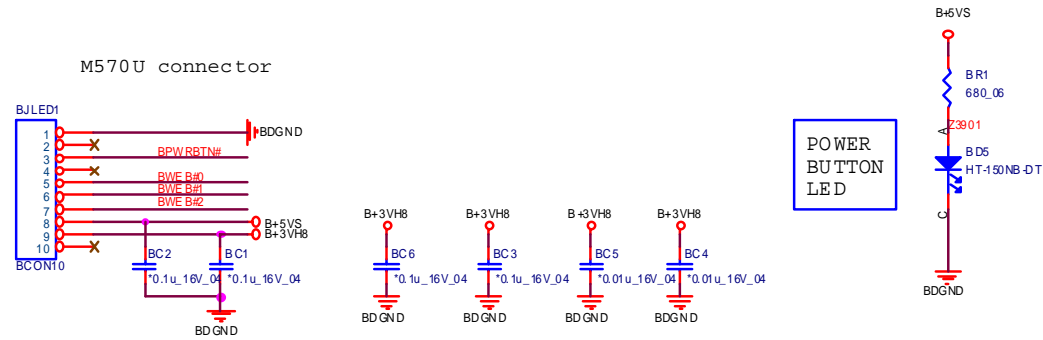

CLICK Board

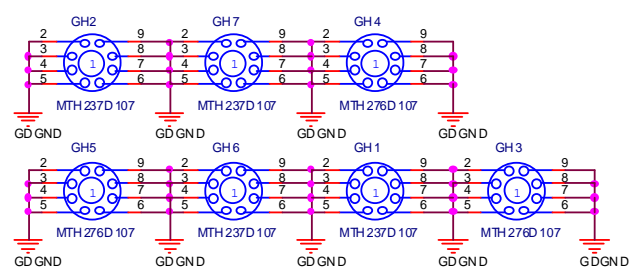
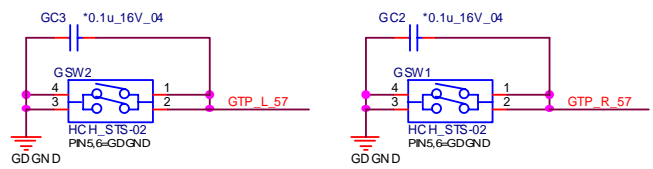
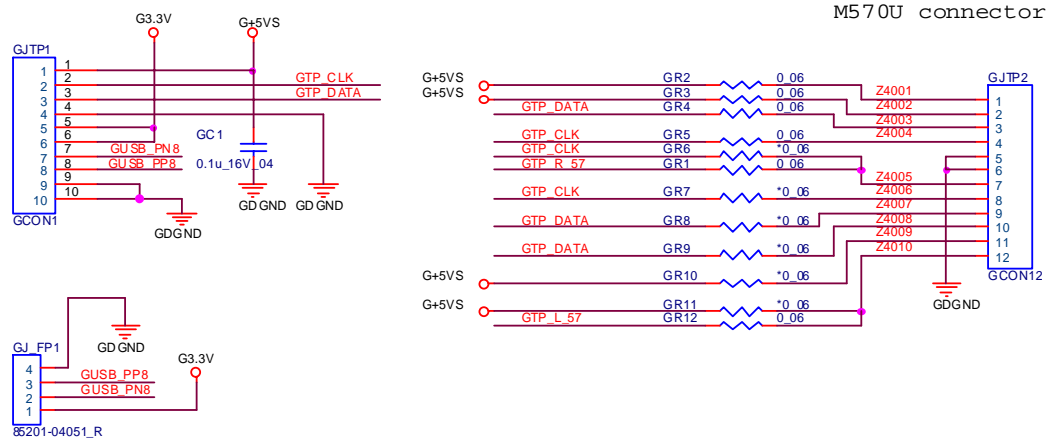

Sheet 40 of 42
CLICK Board

B.Schematic Diagrams

Schematic Diagrams

Fingerprint Board

11/07

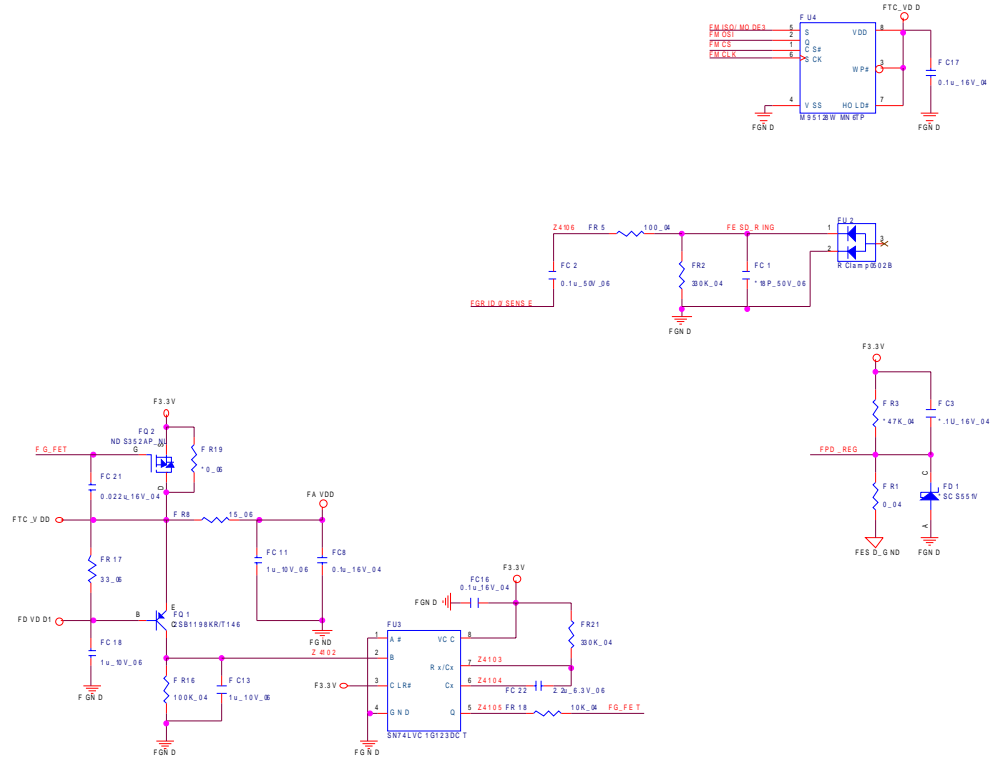
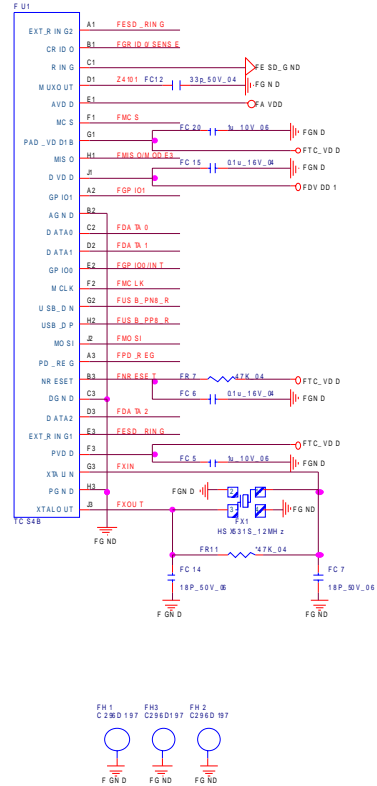
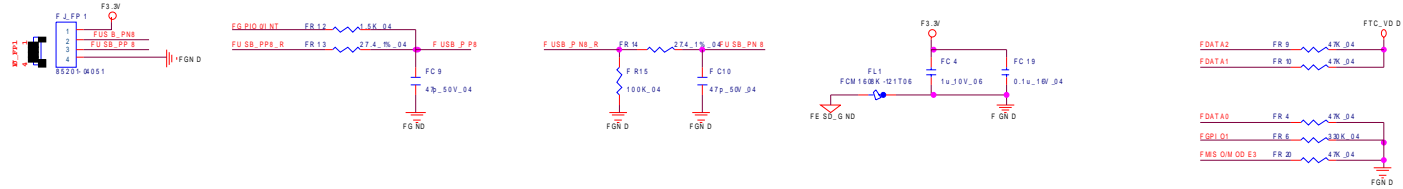

B.Schematic Diagrams

Sheet 41 of 42
Fingerprint Board

DEBUG Board

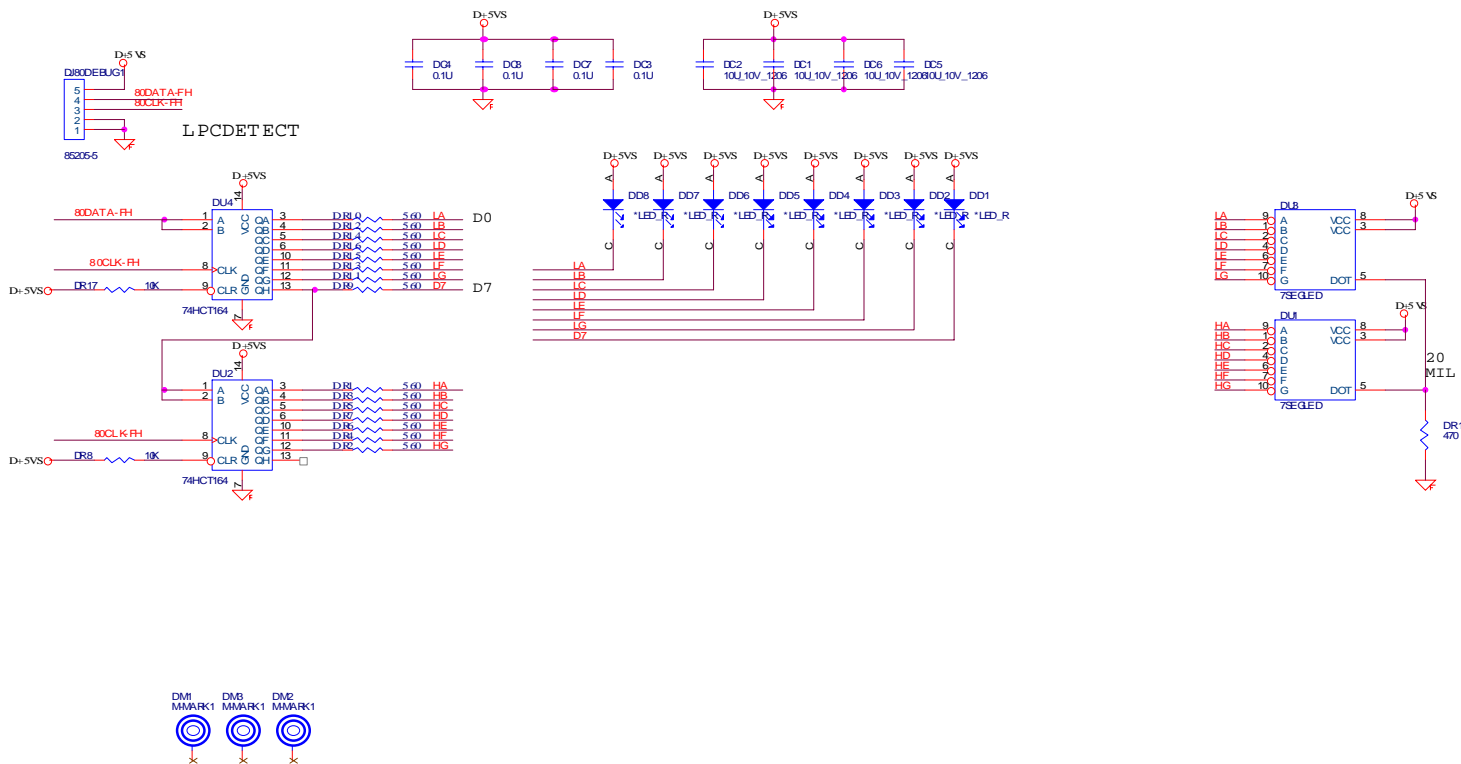

Sheet 42 of 42
DEBUG Board

Schematic Diagrams

www.s-manuals.com