

SERVICE MANUAL

M710L

notebook

Notebook Computer

M710L

Service Manual

Notice

The company reserves the right to revise this publication or to change its contents without notice. Information contained herein is for reference only and does not constitute a commitment on the part of the manufacturer or any subsequent vendor. They assume no responsibility or liability for any errors or inaccuracies that may appear in this publication nor are they in anyway responsible for any loss or damage resulting from the use (or misuse) of this publication.

This publication and any accompanying software may not, in whole or in part, be reproduced, translated, transmitted or reduced to any machine readable form without prior consent from the vendor, manufacturer or creators of this publication, except for copies kept by the user for backup purposes.

Brand and product names mentioned in this publication may or may not be copyrights and/or registered trademarks of their respective companies. They are mentioned for identification purposes only and are not intended as an endorsement of that product or its manufacturer.

Version 1.0
October 2008

Trademarks

Intel and **Atom** are trademarks/registered trademarks of Intel Corporation.

Windows® is a registered trademark of Microsoft Corporation.

Other brand and product names are trademarks and./or registered trademarks of their respective companies.

About this Manual

This manual is intended for service personnel who have completed sufficient training to undertake the maintenance and inspection of personal computers.

It is organized to allow you to look up basic information for servicing and/or upgrading components of the *M710L* series notebook PC.

The following information is included:

Chapter 1, Introduction, provides general information about the location of system elements and their specifications.

Chapter 2, Disassembly, provides step-by-step instructions for disassembling parts and subsystems and how to upgrade elements of the system.

Appendix A, Part Lists

Appendix B, Schematic Diagrams

FCC Statement (Federal Communications Commission)

You are cautioned that changes or modifications not expressly approved by the party responsible for compliance could void the user's authority to operate the equipment.



Warning

Use only shielded cables to connect I/O devices to this equipment. You are cautioned that changes or modifications not expressly approved by the manufacturer for compliance with the above standards could void your authority to operate the equipment.

If your purchase option includes both **Wireless LAN** and **3.5G** modules, then the appropriate antennas will be installed. Note that in order to comply with FCC RF exposure compliance requirements, the antenna must not be co-located or operate in conjunction with any other antenna or transmitter.

This equipment has been tested and found to comply with the limits for a Class B digital device, pursuant to Part 15 of the FCC Rules. These limits are designed to provide reasonable protection against harmful interference in a residential installation. This equipment generates, uses and can radiate radio frequency energy and, if not installed and used in accordance with the instructions, may cause harmful interference to radio communications. However, there is no guarantee that interference will not occur in a particular installation. If this equipment does cause harmful interference to radio or television reception, which can be determined by turning the equipment off and on, the user is encouraged to try to correct the interference by one or more of the following measures:

- Re orient or relocate the receiving antenna.
- Increase the separation between the equipment and receiver.
- Connect the equipment into an outlet on a circuit different from that to which the receiver is connected.
- Consult the service representative or an experienced radio/TV technician for help.

Operation is subject to the following two conditions:

1. This device may not cause interference.
And
2. This device must accept any interference, including interference that may cause undesired operation of the device.

FCC RF Radiation Exposure Statement:

1. This Transmitter must not be co-located or operating in conjunction with any other antenna or transmitter.
2. This equipment complies with FCC RF radiation exposure limits set forth for an uncontrolled environment. This equipment should be installed and operated with a minimum distance of 20 centimeters between the radiator and you body.

IMPORTANT SAFETY INSTRUCTIONS

Follow basic safety precautions, including those listed below, to reduce the risk of fire, electric shock and injury to persons when using any electrical equipment:

1. Do not use this product near water, for example near a bath tub, wash bowl, kitchen sink or laundry tub, in a wet basement or near a swimming pool.
2. Avoid using a telephone (other than a cordless type) during an electrical storm. There may be a remote risk of electrical shock from lightning.
3. Do not use the telephone to report a gas leak in the vicinity of the leak.
4. Use only the power cord and batteries indicated in this manual. Do not dispose of batteries in a fire. They may explode. Check with local codes for possible special disposal instructions.
5. This product is intended to be supplied by a Listed Power Unit (DC Output 19V, 3.42A or 18.5V, 3.5A **(65W)** AC/DC Adapter).

CAUTION

Always disconnect all telephone lines from the wall outlet before servicing or disassembling this equipment.

**TO REDUCE THE RISK OF FIRE, USE ONLY NO. 26 AWG OR LARGER,
TELECOMMUNICATION LINE CORD**

This Computer's Optical Device is a Laser Class 1 Product

Instructions for Care and Operation

The notebook computer is quite rugged, but it can be damaged. To prevent this, follow these suggestions:

1. **Don't drop it, or expose it to shock.** If the computer falls, the case and the components could be damaged.



2. **Keep it dry, and don't overheat it.** Keep the computer and power supply away from any kind of heating element. This is an electrical appliance. If water or any other liquid gets into it, the computer could be badly damaged.

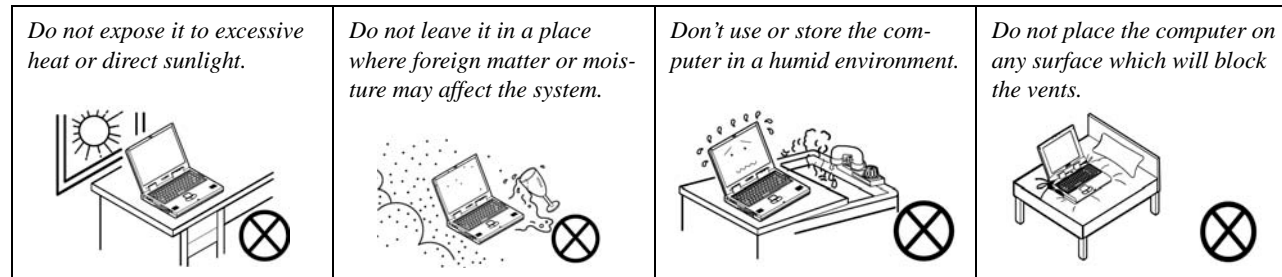

3. **Follow the proper working procedures for the computer.** Shut the computer down properly and don't forget to save your work. Remember to periodically save your data as data may be lost if the battery is depleted.

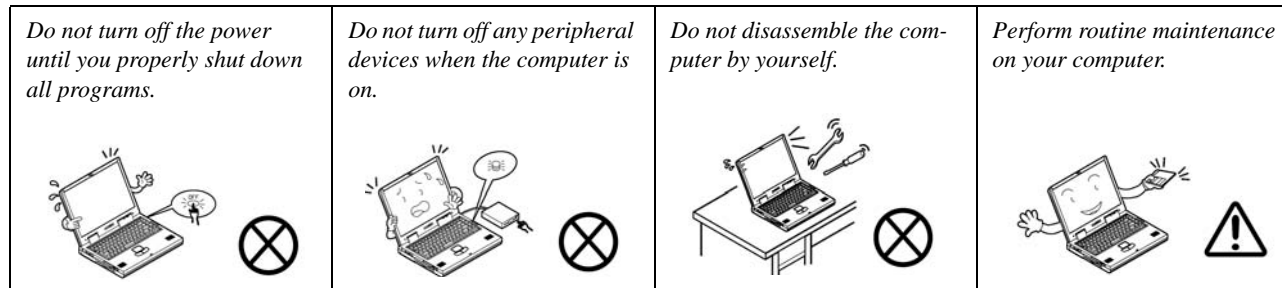

4. **Avoid interference.** Keep the computer away from high capacity transformers, electric motors, and other strong magnetic fields. These can hinder proper performance and damage your data.
5. **Take care when using peripheral devices.**

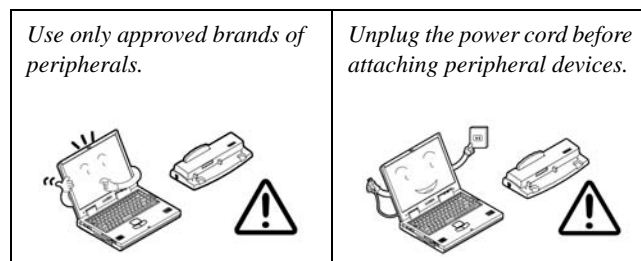

Power Safety

The computer has specific power requirements:

- Only use a power adapter approved for use with this computer.
- Your AC adapter may be designed for international travel but it still requires a steady, uninterrupted power supply. If you are unsure of your local power specifications, consult your service representative or local power company.
- The power adapter may have either a 2-prong or a 3-prong grounded plug. The third prong is an important safety feature; do not defeat its purpose. If you do not have access to a compatible outlet, have a qualified electrician install one.
- When you want to unplug the power cord, be sure to disconnect it by the plug head, not by its wire.
- Make sure the socket and any extension cord(s) you use can support the total current load of all the connected devices.
- Before cleaning the computer, make sure it is disconnected from any external power supplies.

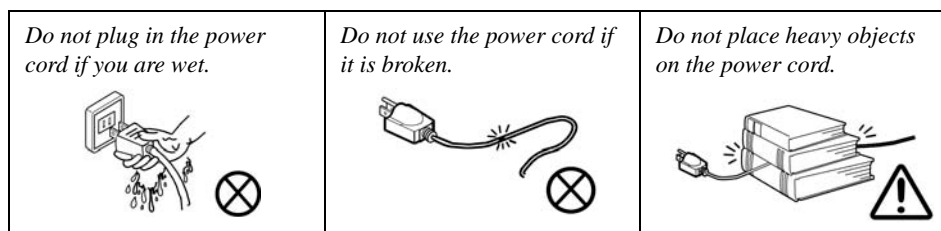

Power Safety Warning

Before you undertake any upgrade procedures, make sure that you have turned off the power, and disconnected all peripherals and cables (including telephone lines). It is advisable to also remove your battery in order to prevent accidentally turning the machine on.

Battery Precautions

- Only use batteries designed for this computer. The wrong battery type may explode, leak or damage the computer.
- Do not continue to use a battery that has been dropped, or that appears damaged (e.g. bent or twisted) in any way. Even if the computer continues to work with a damaged battery in place, it may cause circuit damage, which may possibly result in fire.
- Recharge the batteries using the notebook's system. Incorrect recharging may make the battery explode.
- Do not try to repair a battery pack. Refer any battery pack repair or replacement to your service representative or qualified service personnel.
- Keep children away from, and promptly dispose of a damaged battery. Always dispose of batteries carefully. Batteries may explode or leak if exposed to fire, or improperly handled or discarded.
- Keep the battery away from metal appliances.
- Affix tape to the battery contacts before disposing of the battery.
- Do not touch the battery contacts with your hands or metal objects.



Battery Disposal

The product that you have purchased contains a rechargeable battery. The battery is recyclable. At the end of its useful life, under various state and local laws, it may be illegal to dispose of this battery into the municipal waste stream. Check with your local solid waste officials for details in your area for recycling options or proper disposal.

Caution

Danger of explosion if battery is incorrectly replaced. Replace only with the same or equivalent type recommended by the manufacturer. Discard used battery according to the manufacturer's instructions.

Related Documents

You may also need to consult the following manual for additional information:

User's Manual on CD

This describes the notebook PC's features and the procedures for operating the computer and its ROM-based setup program. It also describes the installation and operation of the utility programs provided with the notebook PC.

Contents

Introduction1-1

Overview	1-1
System Specifications	1-2
External Locator - Top View with LCD Panel Open	1-5
External Locator - Front & Rear Views	1-6
External Locator - Left & Right Side Views	1-7
External Locator - Bottom View	1-8
Mainboard Overview - Top (Key Parts)	1-9
Mainboard Overview - Bottom (Key Parts)	1-10
Mainboard Overview - Top (Connectors)	1-11
Mainboard Overview - Bottom (Connectors)	1-12

Disassembly2-1

Overview	2-1
Maintenance Tools	2-2
Connections	2-2
Maintenance Precautions	2-3
Removing the Battery	2-5
Removing the Hard Disk Drive	2-6
Removing the System Memory (RAM)	2-8
Removing the Heat Sink	2-10
Removing the Wireless LAN Module	2-11
Removing the Bluetooth Module	2-12
Removing the Optical (CD/DVD) Device	2-13
Removing the Keyboard	2-14
Removing the Modem Module	2-15

Part ListsA-1

Part List Illustration Location	A-2
Top	A-3
Bottom	A-4

LCD	A-5
HDD	A-6
Combo	A-7
DVD-COMBO	A-8

Schematic Diagrams.....B-1

SYSTEM BLOCK DIAGRAM	B-2
Diamondville SC 1/2	B-3
Diamondville SC 2/2	B-4
945GSE 1/5, HOST	B-5
945GSE 2/5	B-6
945GSE 3/5, DDR	B-7
945GSE 4/5	B-8
945GSE 5/5	B-9
DDRII SO-DIMM 0	B-10
DDRII SO- DIMM 1	B-11
PANEL, INVERTER, CRT	B-12
CLOCK GENERATOR	B-13
CH7-M 1/4, SATA	B-14
ICH7-M 2/4, PCI, USB, SPI	B-15
ICH7-M 3/4	B-16
ICH7-M 4/4	B-17
MULTI I/O, ODD, CCD BT	B-18
NEW CARD, USB	B-19
CARD READER JMB385	B-20
LED, FAN, PC BEEP, TP, FP	B-21
PCI-E LAN RTL8102E	B-22
AUDIO CODEC ALC269 QFN	B-23
KBC-ITE IT8502E	B-24
3VS, 5VS	B-25
VDD3, VDD5	B-26

Preface

POWER 1.8V/ 0.9V	B-27
POWER 1.5VS/ 1.05VS	B-28
VCORE	B-29
AC IN, CHARGE	B-30
CLICK BOARD	B-31
Multi B'd, LID, LED, SW, USB	B-32
Multi B'd, Mini Card, MDC, RJ11	B-33

Chapter 1: Introduction

Overview

This manual covers the information you need to service or upgrade the *M710L* series notebook computer. Information about operating the computer (e.g. getting started, and the *Setup* utility) is in the *User's Manual*. Information about drivers (e.g. VGA & audio) is also found in *User's Manual*. That manual is shipped with the computer.

Operating systems (e.g. *Windows XP*, *Windows Vista*, etc.) have their own manuals as do application software (e.g. word processing and database programs). If you have questions about those programs, you should consult those manuals.

The *M710L* series notebook is designed to be upgradeable. See *“Disassembly” on page 2 - 1* for a detailed description of the upgrade procedures for each specific component. Please note the warning and safety information indicated by the “” symbol.

The balance of this chapter reviews the computer's technical specifications and features.

System Specifications



Latest Specification Information

The specifications listed in this Appendix are correct at the time of going to press. Certain items (particularly processor types/speeds and CD/DVD device types) may be changed, delayed or updated due to the manufacturer's release schedule. Check with your service center for details.

Feature	Specification
Processor	Intel® Atom™ N270 BGA Package 45nm (45 Nanometer) Process Technology 512 KB L2 Cache & 533 MHz FSB 1.60GHz
Core Logic	Intel® 82945GSE + 82801GBM Chipset
LCD	10.2" WSVGA (1024 * 600) TFT LCD
Memory	64-bit Wide DDRII (DDR2) Data Channel One 200 Pin SO-DIMM Socket Supporting DDRII (DDR2) 533MHz RAM Modules Memory Expandable up to 2GB (1024/2048 MB DDR2 Modules)
Video Adapter	Intel 945GSE Integrated Video Shared Memory Architecture (up to 128MB dynamically allocated from system memory where needed) Supports DirectX9.0
BIOS	One 8Mb SPI Flash ROM Phoenix™ BIOS
Security	Security (Kensington® Type) Lock Slot BIOS Password
Storage	One Changeable 12.7mm(h) SATA (Serial) Optical Device (CD/DVD) Type Drive (see "Optional" on page 1 - 4) Easy Changeable 2.5" 9.5 mm (h) SATA (Serial) HDD
Audio	High Definition Audio (HDA) Compliant with Microsoft UAA (Universal Audio Architecture) Direct Sound 3D™ Compatible 2 * Built-In Speakers Built-In Microphone

Feature	Specification	
Keyboard & Pointing Device	Winkey Keyboard	Built-In TouchPad with Scrolling Function
Interface	Two USB 2.0 Ports (Left Side of Computer) One Headphone-Out Jack One Microphone-In Jack One Internal Microphone	One RJ-11 Modem Jack One RJ-45 LAN Jack One DC-In Jack One External Monitor Port
Card Reader	Embedded 7-in-1 Card Reader (MS/ MS Pro/ SD/ Mini SD/ MMC/ RS MMC/ MS Duo) Note: MS Duo/ Mini SD/ RS MMC Cards require a PC adapter	
Mini-Card Slots	One Mini-Card Slot for Wireless LAN Module	
Communication	10/100Mb Base-T Ethernet LAN 56K Fax Modem 802.11b/g Wireless LAN Mini-Card Module with USB interface (Option) Bluetooth 2.0 + EDR (Enhanced Data Rate) Module (Factory Option) 1.3M or 2.0M Pixel PC Camera Module with USB interface (Factory Option)	
Power Management	Supports ACPI 3.0	Supports Wake on LAN (From Sleep) Supports Resume from Modem Ring (From Sleep)
Power	Full Range AC/DC Adapter AC Input 100 - 240V, DC Output 50 - 60Hz, 19V, 3.42A or 18.5V, 3.5A (65 Watts)	
Battery	4 Cell Smart Lithium-Ion Battery Pack, 2400mAH 2 Cell Smart Lithium-Ion Battery Pack, 2200mAH (Option) 8 Cell Smart Lithium-Ion Battery Pack, 4400mAH (Option) Battery Life 4 Hours with 4 Cell Battery (Without ODD Use)	
Environmental Spec	Temperature Operating: 5°C - 35°C Non-Operating: -20°C - 60°C	Relative Humidity Operating: 20% - 80% Non-Operating: 10% - 90%
Dimensions & Weight	299mm (w) * 219mm (d) * 26.5-35.7mm (h)	Around 1.6 kg With 2 Cell Battery and Without ODD

Introduction

Feature	Specification
Optional	<p>Optical Drive Module Options: SATA DVD/CD-RW Combo Drive Module SATA DVD Super Multi Drive Module</p> <p>8 Cell Smart Lithium-Ion Battery Pack 2 Cell Smart Lithium-Ion Battery Pack</p> <p>1.3M or 2.0M Pixel USB PC Camera Module (Factory Option)</p> <p>802.11b/g Wireless LAN Mini-Card Module with USB interface</p> <p>Bluetooth 2.0 + EDR (Enhanced Data Rate) Module (Factory Option)</p>

External Locator - Top View with LCD Panel Open



Figure 1
Top View

1. Built-In PC Camera
Camera
(Optional)
2. LCD
3. Speaker
4. Power Button
5. Hot-Key Buttons
6. LED Status Indicators
7. Keyboard
8. Touchpad & Buttons
9. LED Power & Communication Indicators
10. Built-in Microphone

Introduction

Figure 2
Front View

1. LED Power & Communication Indicators
2. 7-in-1 Card Reader
3. Microphone-In Jack
4. Headphone-Out Jack

External Locator - Front & Rear Views

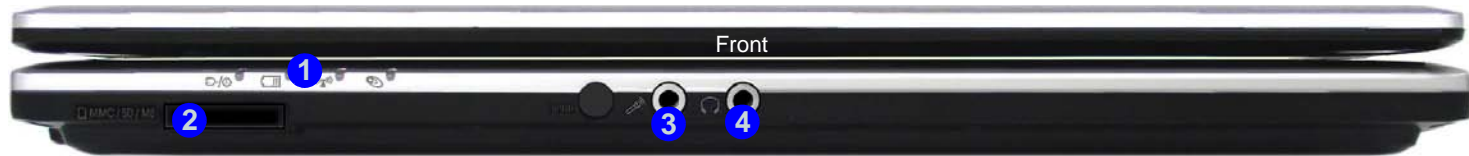
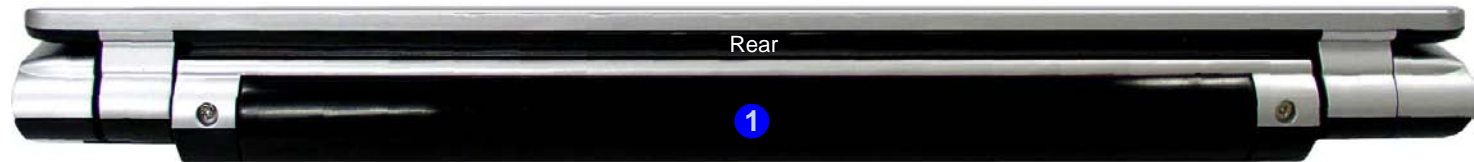

Figure 3
Rear View

1. Battery



External Locator - Left & Right Side Views

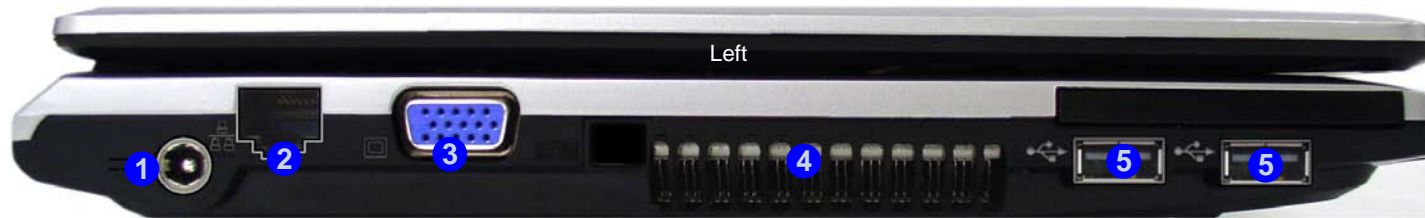

Figure 4
Left Side View

1. DC-In Jack
2. RJ-45 LAN Jack
3. External Monitor Port
4. Vent
5. 2 * USB 2.0 Ports



Figure 5
Right Side View

1. Optical Device Drive Bay
2. Emergency Eject Hole
3. RJ-11 Phone Jack
4. Security Lock Slot

External Locator - Bottom View

Figure 6
Bottom View

1. Battery
2. Hard Disk Bay Cover
3. RAM & CPU Bay Cover

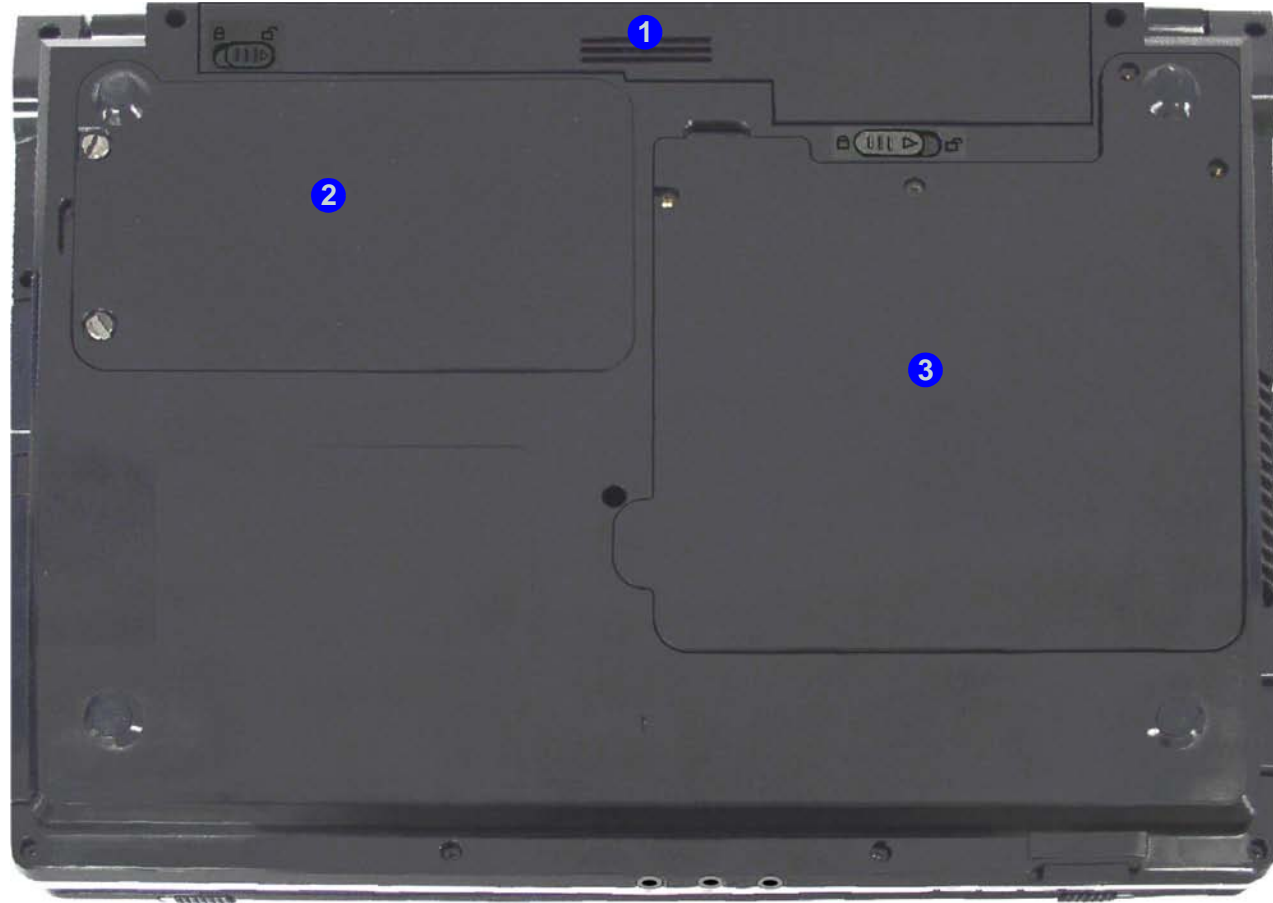

Overheating

To prevent your computer from overheating make sure nothing blocks the vent/fan intakes while the computer is in use.

Mainboard Overview - Top (Key Parts)

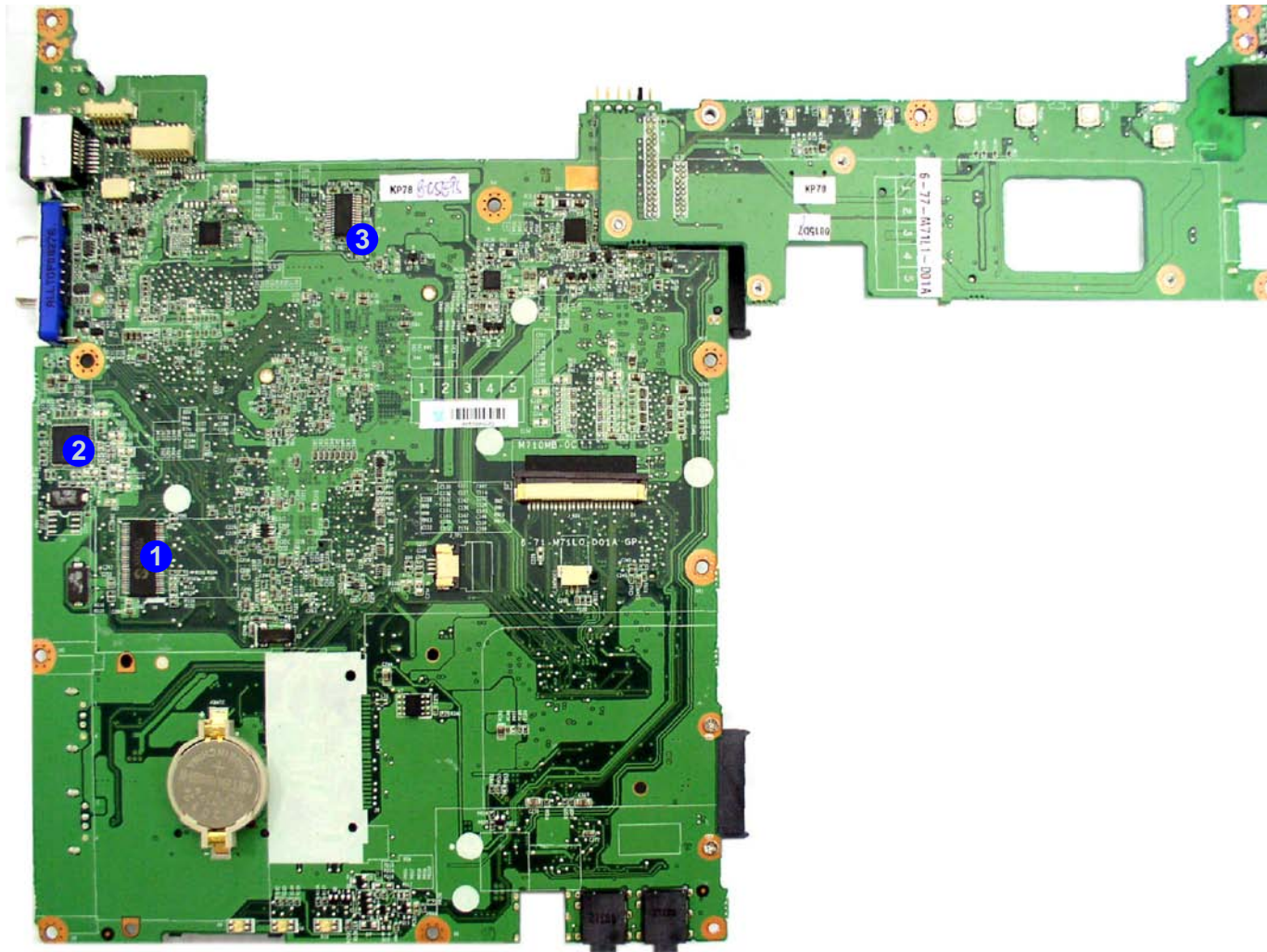

Figure 7
**Mainboard Top
Key Parts**

1. CLOCK GENERATOR
2. RTL8102E
3. SC413

Introduction

Figure 8
**Mainboard Bottom
Key Parts**

1. North Bridge
2. Intel Diamondville Processor
3. South Bridge
4. Card Reader Controller JM8385
5. Realtek ALC269
6. ITE
7. Memory Slot DDRII So-DIMM
8. HDD Connector
9. WLAN Connector

Mainboard Overview - Bottom (Key Parts)

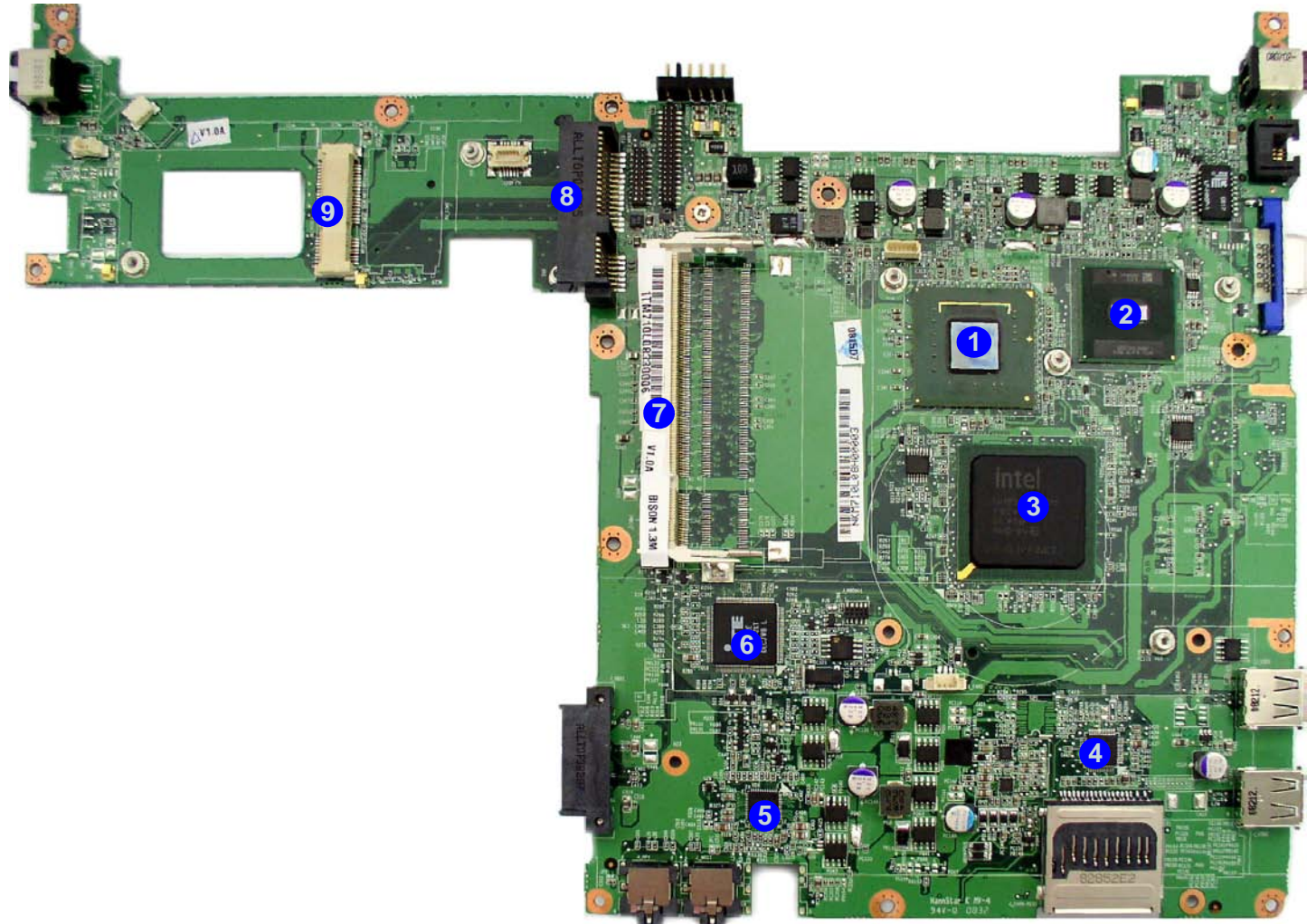

Mainboard Overview - Top (Connectors)

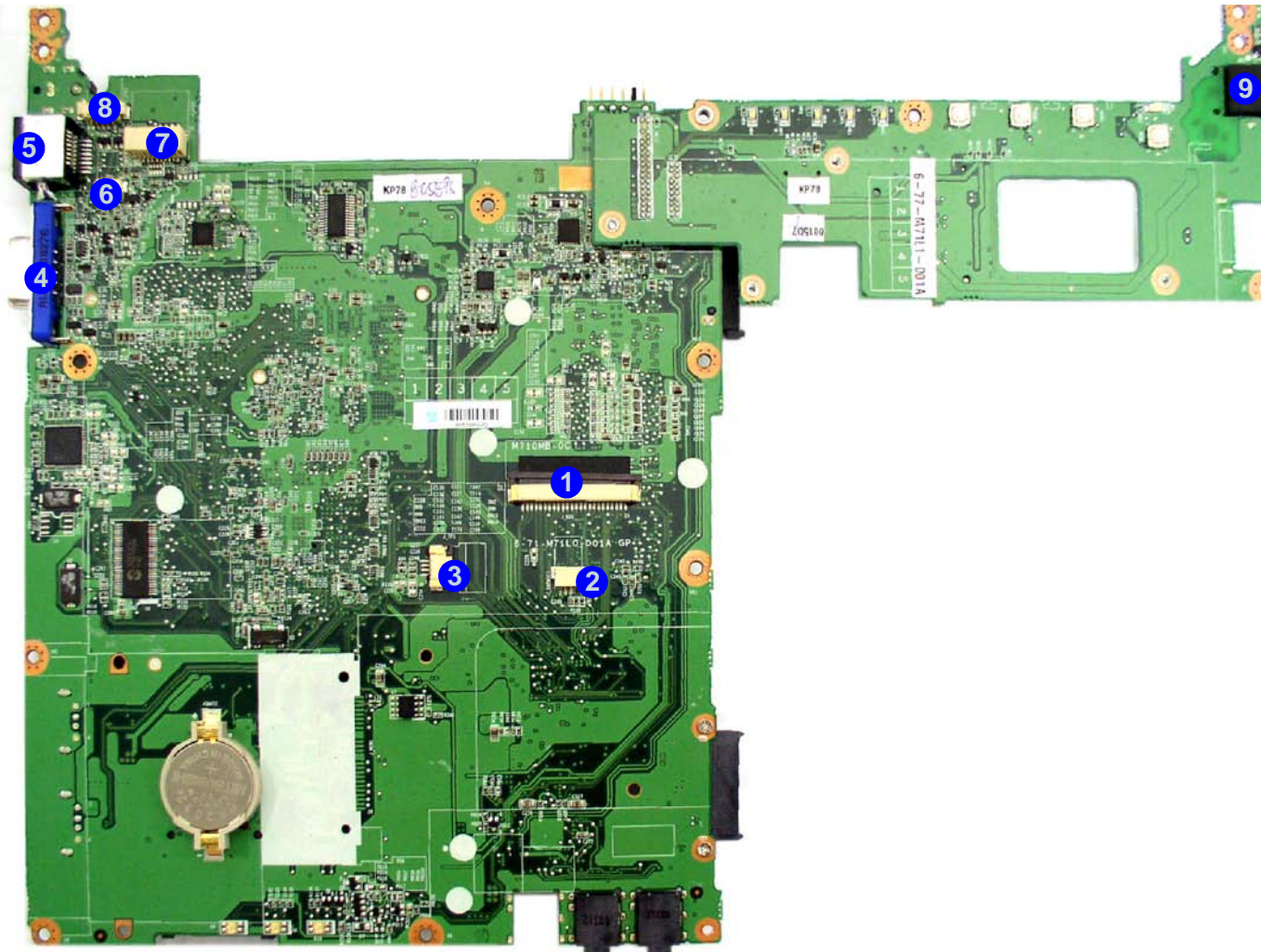

Figure 9
Mainboard Top Connectors

1. Keyboard Cable Connector
2. Internal Microphone Cable Connector
3. Touch Pad Cable Connector
4. External Monitor Port
5. RJ-45 LAN Jack
6. Speaker Cable Connector
7. LCD Cable Connector
8. CCD Cable Connector
9. RJ-11 Phone Jack

Introduction

Figure 10
**Mainboard Bottom
Connectors**

Mainboard Overview - Bottom (Connectors)

1. RJ-11 Phone Jack
2. Modem Cable Connector
3. Speaker Cable Connector
4. Modem Connector
5. Battery Connector
6. Bluetooth Cable Connector
7. DC-In Jack
8. RJ-45 LAN Jack
9. External Monitor Port
10. USB Ports
11. Card Reader
12. Fan Cable Connector
13. Microphone-In Jack
14. Headphone-Out Jack
15. Optical Device Drive Connector

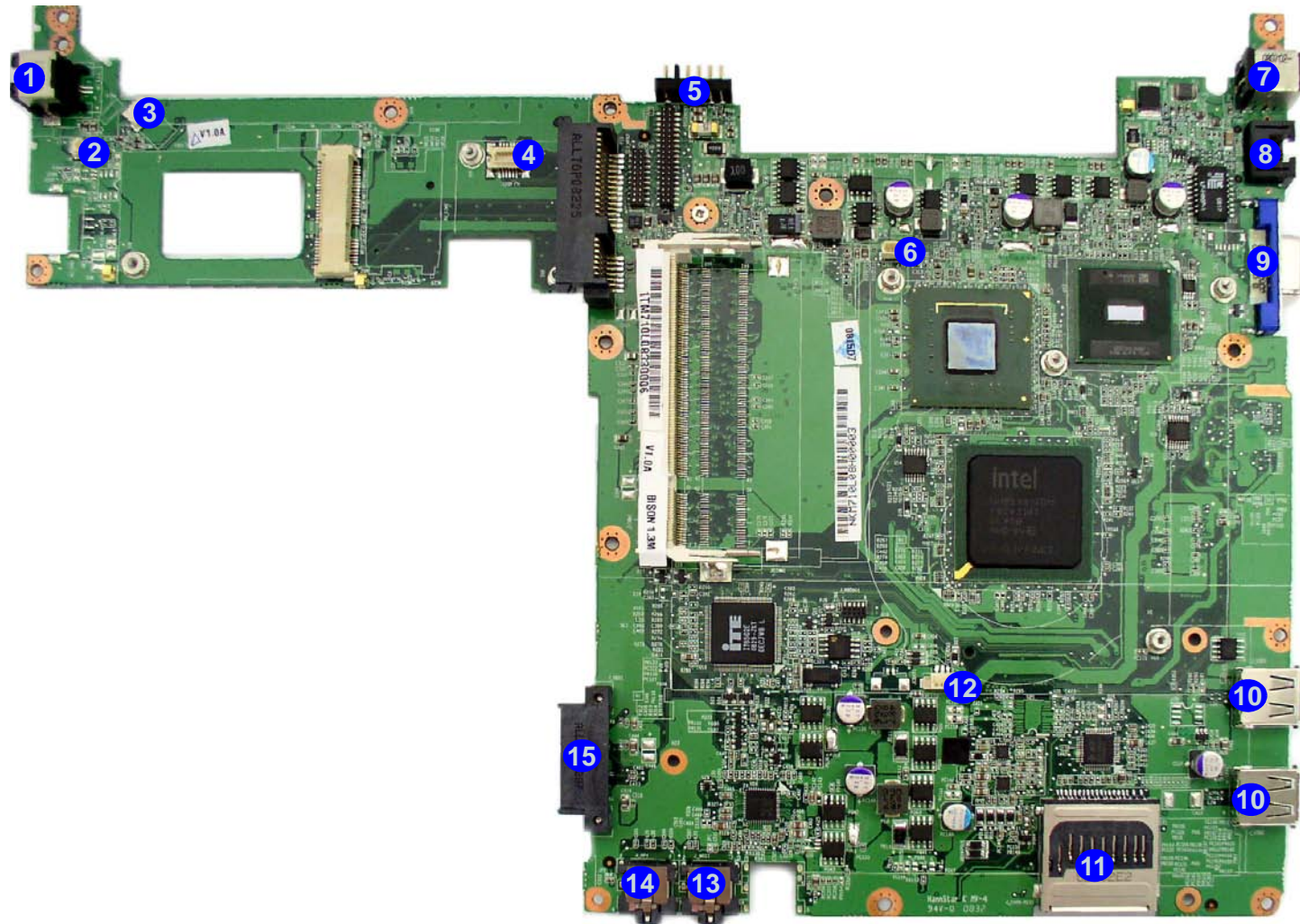

Chapter 2: Disassembly



Overview

This chapter provides step-by-step instructions for disassembling the *M710L* series notebook's parts and subsystems. When it comes to reassembly, reverse the procedures (unless otherwise indicated).

We suggest you completely review any procedure before you take the computer apart.

Procedures such as upgrading/replacing the RAM, CD device and hard disk are included in the User's Manual but are repeated here for your convenience.

To make the disassembly process easier each section may have a box in the page margin. Information contained under the figure # will give a synopsis of the sequence of procedures involved in the disassembly procedure. A box with a  lists the relevant parts you will have after the disassembly process is complete. **Note:** The parts listed will be for the disassembly procedure listed ONLY, and not any previous disassembly step(s) required. Refer to the part list for the previous disassembly procedure. The amount of screws you should be left with will be listed here also.

A box with a  will also provide any possible helpful information. A box with a  contains warnings.

An example of these types of boxes are shown in the sidebar.

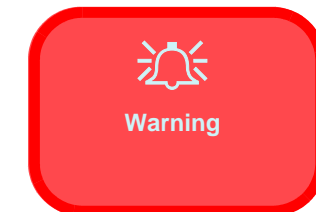
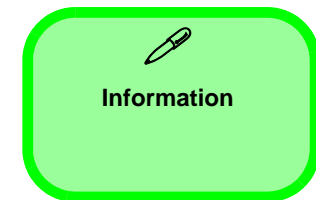

Disassembly

NOTE: All disassembly procedures assume that the system is turned **OFF**, and disconnected from any power supply (the battery is removed too).

Maintenance Tools

The following tools are recommended when working on the notebook PC:

- M3 Philips-head screwdriver
- M2.5 Philips-head screwdriver (magnetized)
- M2 Philips-head screwdriver
- Small flat-head screwdriver
- Pair of needle-nose pliers
- Anti-static wrist-strap

Connections

Connections within the computer are one of four types:

Locking collar sockets for ribbon connectors	To release these connectors, use a small flat-head screwdriver to gently pry the locking collar away from its base. When replacing the connection, make sure the connector is oriented in the same way. The pin1 side is usually not indicated.
Pressure sockets for multi-wire connectors	To release this connector type, grasp it at its head and gently rock it from side to side as you pull it out. Do not pull on the wires themselves. When replacing the connection, do not try to force it. The socket only fits one way.
Pressure sockets for ribbon connectors	To release these connectors, use a small pair of needle-nose pliers to gently lift the connector away from its socket. When replacing the connection, make sure the connector is oriented in the same way. The pin1 side is usually not indicated.
Board-to-board or multi-pin sockets	To separate the boards, gently rock them from side to side as you pull them apart. If the connection is very tight, use a small flat-head screwdriver - use just enough force to start.

Maintenance Precautions

The following precautions are a reminder. To avoid personal injury or damage to the computer while performing a removal and/or replacement job, take the following precautions:

1. **Don't drop it.** Perform your repairs and/or upgrades on a stable surface. If the computer falls, the case and other components could be damaged.
2. **Don't overheat it.** Note the proximity of any heating elements. Keep the computer out of direct sunlight.
3. **Avoid interference.** Note the proximity of any high capacity transformers, electric motors, and other strong magnetic fields. These can hinder proper performance and damage components and/or data. You should also monitor the position of magnetized tools (i.e. screwdrivers).
4. **Keep it dry.** This is an electrical appliance. If water or any other liquid gets into it, the computer could be badly damaged.
5. **Be careful with power.** Avoid accidental shocks, discharges or explosions.
 - Before removing or servicing any part from the computer, turn the computer off and detach any power supplies.
 - When you want to unplug the power cord or any cable/wire, be sure to disconnect it by the plug head. Do not pull on the wire.
6. **Peripherals** – Turn off and detach any peripherals.
7. **Beware of static discharge.** ICs, such as the CPU and main support chips, are vulnerable to static electricity. Before handling any part in the computer, discharge any static electricity inside the computer. When handling a printed circuit board, do not use gloves or other materials which allow static electricity buildup. We suggest that you use an anti-static wrist strap instead.
8. **Beware of corrosion.** As you perform your job, avoid touching any connector leads. Even the cleanest hands produce oils which can attract corrosive elements.
9. **Keep your work environment clean.** Tobacco smoke, dust or other air-borne particulate matter is often attracted to charged surfaces, reducing performance.
10. **Keep track of the components.** When removing or replacing any part, be careful not to leave small parts, such as screws, loose inside the computer.

Cleaning

Do not apply cleaner directly to the computer, use a soft clean cloth.

Do not use volatile (petroleum distillates) or abrasive cleaners on any part of the computer.



Power Safety Warning

Before you undertake any upgrade procedures, make sure that you have turned off the power, and disconnected all peripherals and cables (including telephone lines). It is advisable to also remove your battery in order to prevent accidentally turning the machine on.

Disassembly Steps

The following table lists the disassembly steps, and on which page to find the related information. **PLEASE PERFORM THE DISASSEMBLY STEPS IN THE ORDER INDICATED.**

To remove the Battery:

1. Remove the battery [page 2 - 5](#)

To remove the HDD:

1. Remove the battery [page 2 - 5](#)
2. Remove the HDD [page 2 - 6](#)

To remove the System Memory:

1. Remove the battery [page 2 - 5](#)
2. Remove the system memory [page 2 - 8](#)

To remove the Heat Sink:

1. Remove the battery [page 2 - 5](#)
2. Remove the heat sink [page 2 - 10](#)

To remove the Wireless LAN Module:

1. Remove the battery [page 2 - 5](#)
2. Remove the Wireless LAN [page 2 - 11](#)

To remove the Bluetooth:

1. Remove the battery [page 2 - 5](#)
2. Remove the bluetooth [page 2 - 12](#)

To remove the Optical Device:

1. Remove the battery [page 2 - 5](#)
2. Remove the Optical device [page 2 - 13](#)

To remove the Keyboard:

1. Remove the battery [page 2 - 5](#)
2. Remove the keyboard [page 2 - 14](#)

To remove the Modem :

1. Remove the battery [page 2 - 5](#)
2. Remove the HDD [page 2 - 6](#)
3. Remove the heat sink [page 2 - 10](#)
4. Remove the Wireless LAN [page 2 - 11](#)
5. Remove the bluetooth [page 2 - 12](#)
6. Remove the Optical device [page 2 - 13](#)
7. Remove the keyboard [page 2 - 14](#)
8. Remove the modem [page 2 - 15](#)

Removing the Battery

1. Turn the computer **off**, and turn it over.
2. Slide the latches (1 & 2) the direction of the arrow, and hold latch 2 in place.
3. Slide the battery in the direction of the arrow 3.

Figure 1
Battery Removal

- a. Slide the 2 latches and hold latch 2 in place.
- b. Slide the battery in the direction of the arrow.

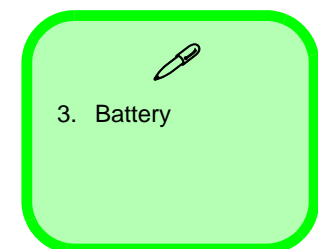
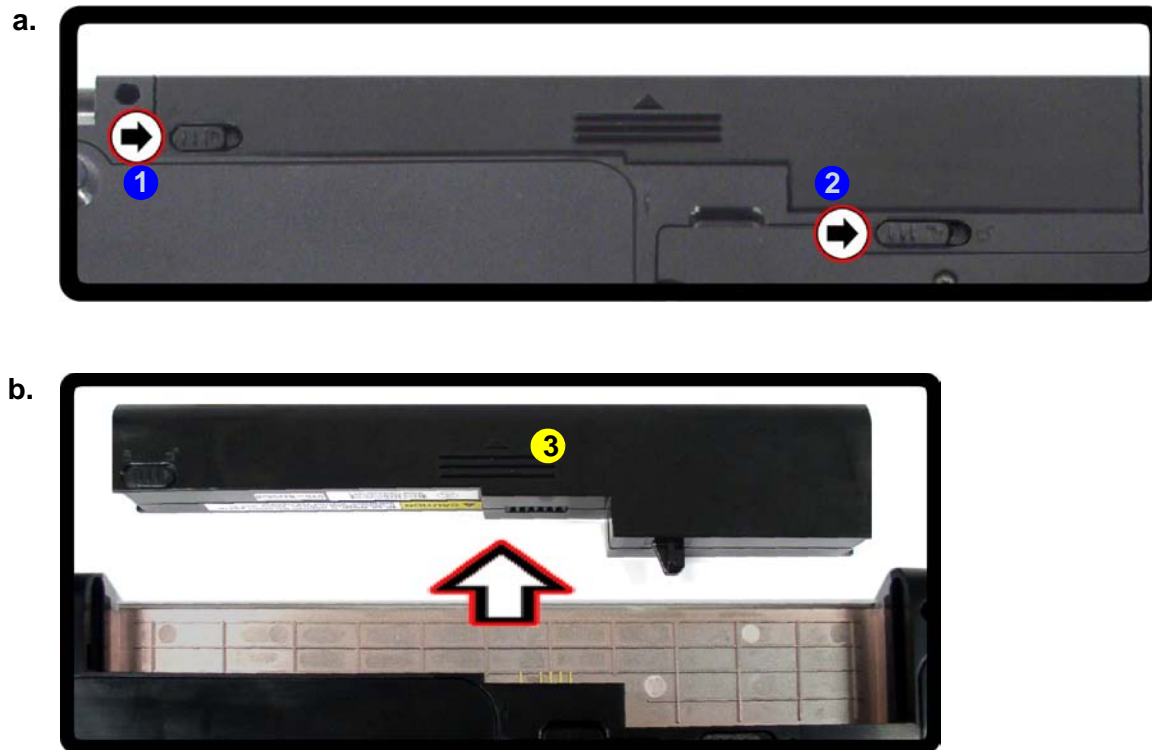

Disassembly

Figure 2
**HDD Assembly
Removal**

- Locate the HDD bay cover and remove the screws.
- Remove the bay cover.

Removing the Hard Disk Drive

The hard disk drive can be taken out to accommodate other 2.5" serial (SATA) hard disk drives with a height of 9.5mm (h). Follow your operating system's installation instructions, and install all necessary drivers and utilities (as outlined in **Chapter 4 of the User's Manual**) when setting up a new hard disk.

Hard Disk Upgrade Process:

- Turn **off** the computer, and remove the battery ([page 2 - 5](#)).
- Locate the hard disk bay cover and remove the screws (1 - 2).
- Remove the bay cover (3).

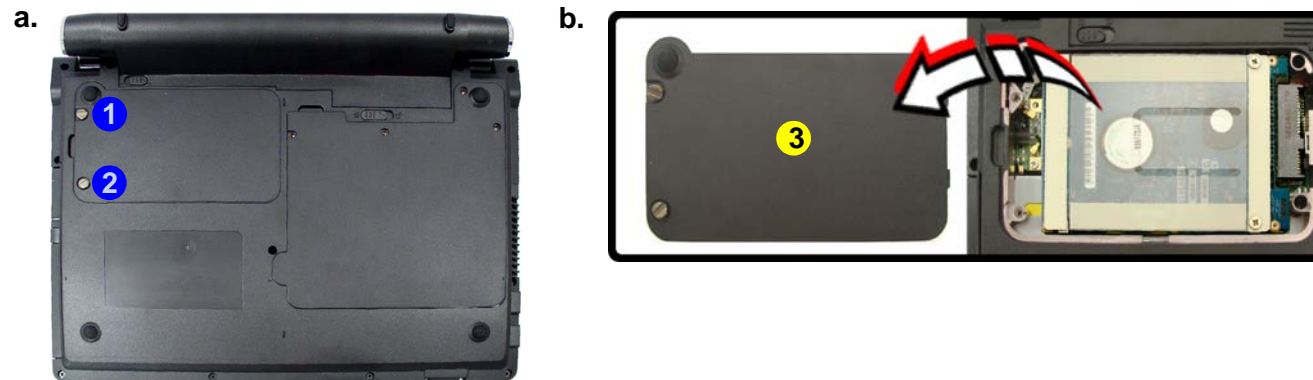

3. HDD Bay Cover

- 2 Screws



HDD System Warning

New HDD's are blank. Before you begin make sure:

You have backed up any data you want to keep from your old HDD.

You have all the CD-ROMs and FDDs required to install your operating system and programs.

If you have access to the internet, download the latest application and hardware driver updates for the operating system you plan to install. Copy these to a removable medium.

- Carefully grip the mylar cover tab **4** and slide the hard disk in the direction of arrow.
- Lift the hard disk up (**Figure d**) in the direction of arrow.
- Remove the screws **5** - **6** and separate the mylar cover **7** from the hard disk **8**.
- Reverse the process to install any new hard disk.

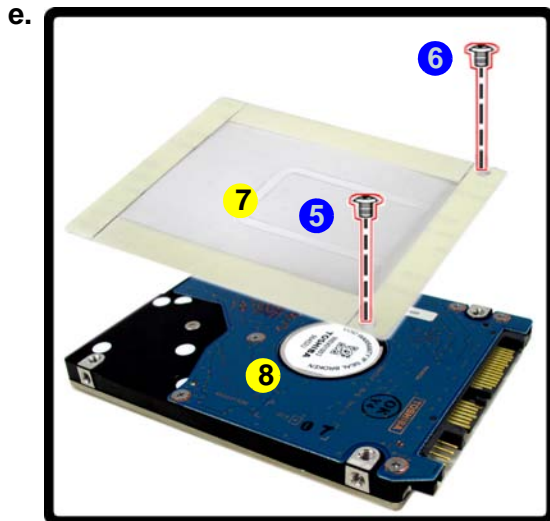
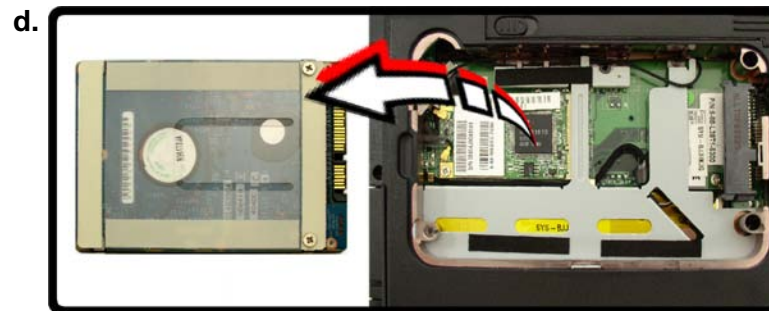

Figure 3
**HDD Assembly
Removal Sequence**

- Slide the HDD in the direction of the arrow.
- Lift the HDD out of the bay.
- Remove the screws and separate the mylar cover from the HDD.

- 
- 7. Mylar Cover
 - 8. HDD
 - 2 Screws

Figure 4
**RAM Module
Removal**

- Remove the screws.
- Disconnect the fan cable and remove the cover.



Contact Warning

Be careful not to touch the metal pins on the module's connecting edge. Even the cleanest hands have oils which can attract particles, and degrade the module's performance.



6. CPU/RAM Bay Cover

- 4 Screws

Removing the System Memory (RAM)

The computer has **one** memory socket for 200 pin Small Outline Dual In-line (SO-DIMM) **DDRII (DDR2)** type memory modules. The total memory size is automatically detected by the POST routine once you turn on your computer.

Memory Upgrade Process

- Turn **off** the computer, remove the battery ([page 2 - 5](#)).
- Locate the CPU/RAM bay cover, and remove screws **1** - **4**.
- Carefully (a fan and cable are attached to the under side of the cover) lift up the bay cover.
- Carefully disconnect the fan cable **5**.
- Remove the bay cover **6**.
- The RAM will be visible at point **7** on the mainboard.

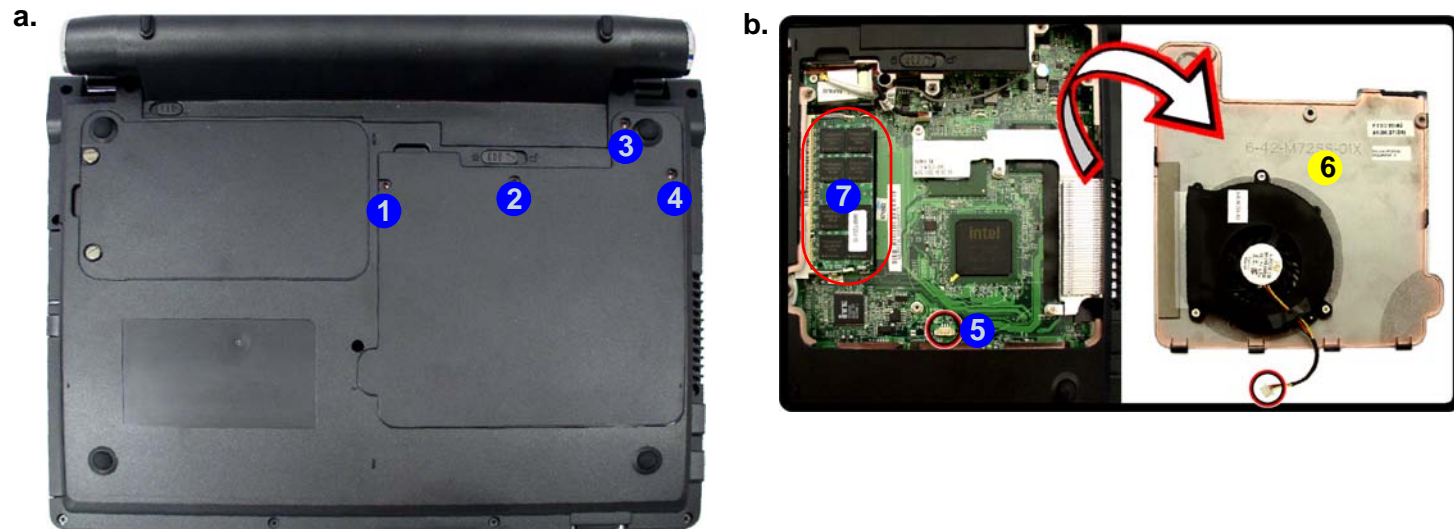
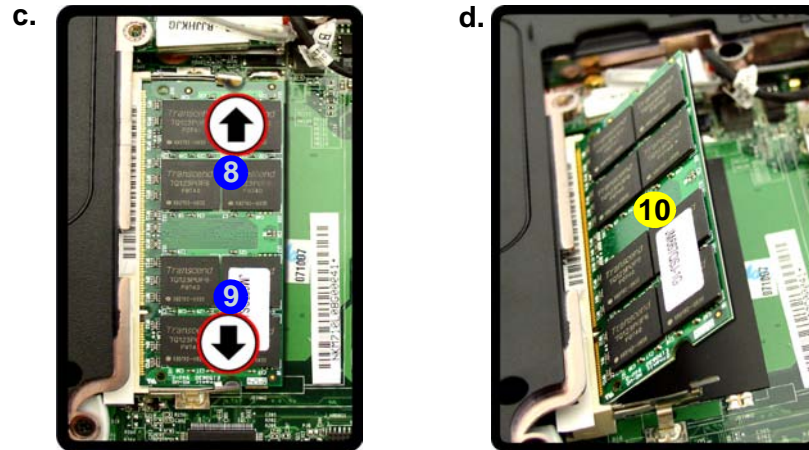

Figure 5
Memory Removal Sequence

- c. Push the release latch(es).
- d. Remove the module(s).



- 7. Gently push the two release latches (8 & 9) on the sides of the memory socket in the direction indicated by the arrows (Figure d).
- 8. The RAM module(s) 10 will pop-up (Figure d), and you can then remove it.

- 9. Insert a new module holding it at about a 30° angle and fit the connectors firmly into the memory slot.
- 10. The module will only fit one way as defined by its pin alignment. Make sure the module is seated as far into the slot as it will go. **DO NOT FORCE IT**; it should fit without much pressure.
- 11. Press the module down towards the mainboard until the slot levers click into place to secure the module.
- 12. Replace the bay cover and the screws (**make sure you reconnect the fan cable before screwing down the bay cover - Figure b**).
- 13. Restart the computer to allow the BIOS to register the new memory configuration as it starts up.

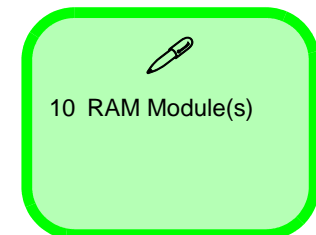

Disassembly

Figure 6

Processor Removal

- Locate the heat sink.
- Loosen the screws in the reverse order indicated.
- Remove the heat sink.

Removing the Heat Sink

- Turn off the computer, turn it over and remove the battery ([page 2 - 5](#)) and the component bay cover ([page 2 - 8](#)).
- The CPU heat sink will be visible at point **A** on the mainboard.
- Loosen screws **4**, **3**, **2**, **1** ([Figure 6b](#)) the reverse order as indicated on the label.
- Carefully lift the heat sink **B** ([Figure 6c](#)) up and off the computer.
- Reverse the process to install the heat sink.

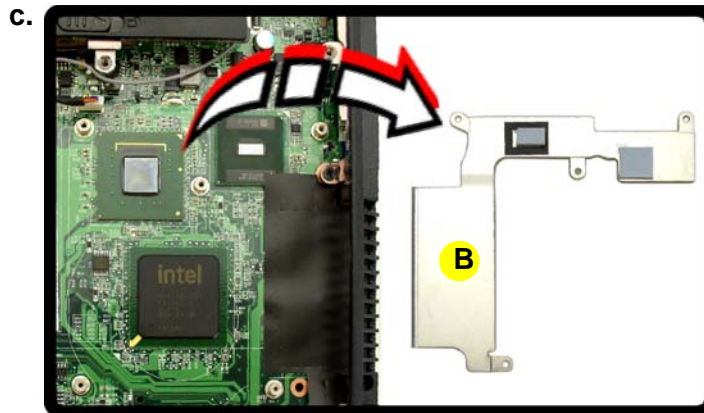
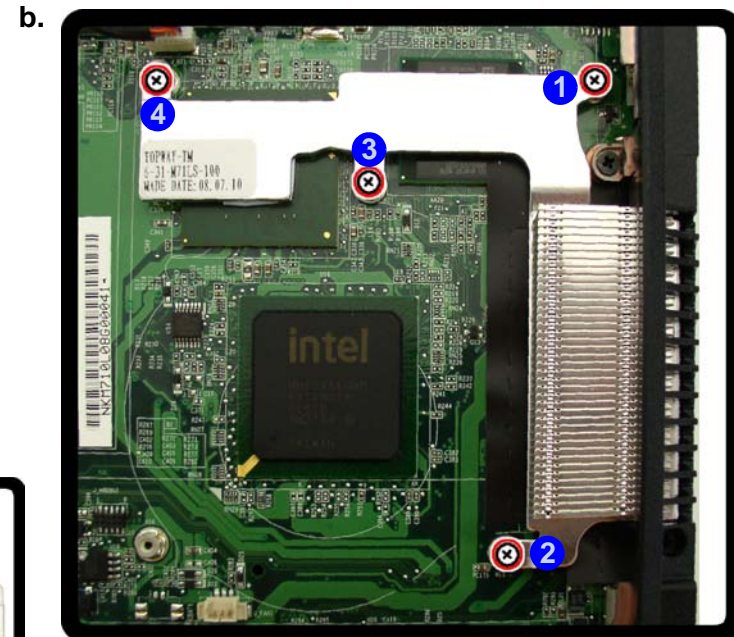
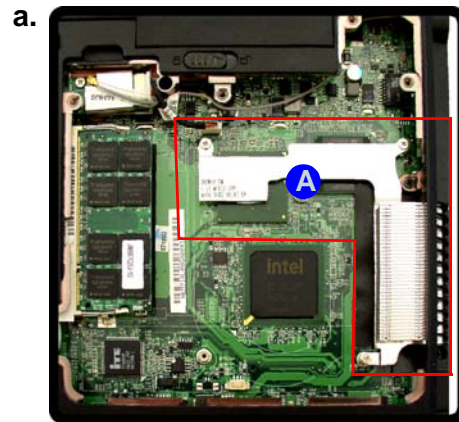

B. Heat Sink

- 4 Screws

Removing the Wireless LAN Module

1. Turn **off** the computer, remove the battery ([page 2 - 5](#)) and the HDD bay cover([page 2 - 8](#)).
2. Remove the HDD module.
3. The Wireless LAN module will be visible at point **1** on the mainboard.
4. Carefully disconnect cables **2** - **3**, and then remove screw **4** from the module socket.
5. The Wireless LAN module **5** will pop-up.
6. Lift the Wireless LAN module ([Figure d](#)) up and off the computer.

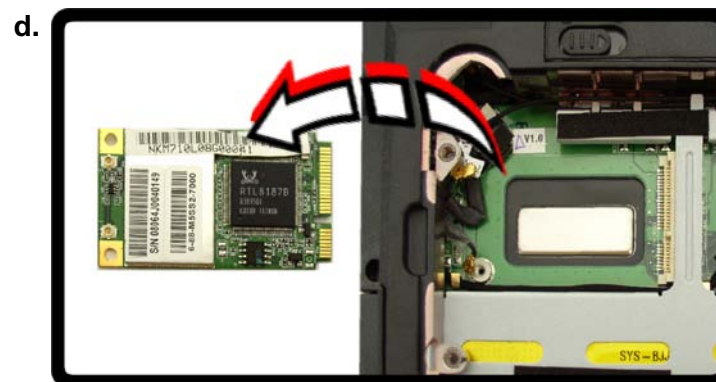
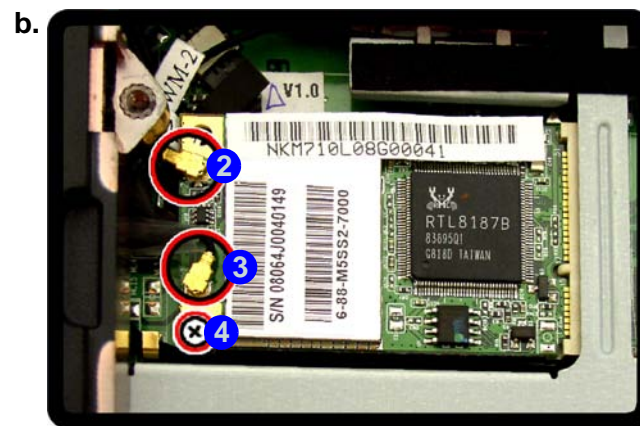
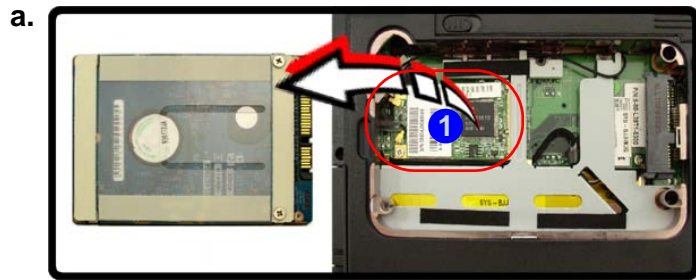
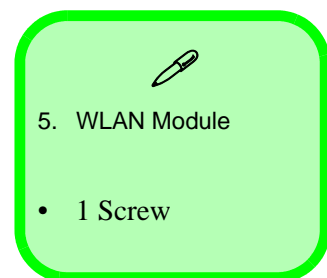

Figure 7
**Wireless LAN
Module Removal**

- a. Remove the HDD module and locate the WLAN module.
- b. Disconnect the cables and remove the screw.
- c. The WLAN module will pop up.
- d. Remove the WLAN module.

Note: Make sure you reconnect the antenna cable to “1” + “2” socket ([Figure 7b](#)).



Disassembly

Figure 8
Bluetooth Removal

- Remove the cover and locate the Bluetooth module.
- Remove the screw and disconnect the cable and separate the connector.
- Lift the Bluetooth module out.

Removing the Bluetooth Module

- Turn **off** the computer, remove the battery ([page 2 - 5](#)), and the CPU/RAM bay cover ([page 2 - 8](#)).
- The Bluetooth module will be visible at point **1** on the mainboard.
- Remove screw **2** and carefully disconnect the cable **3** and separate the module from the connector **4**.
- Lift the Bluetooth module **5** up and off the computer.

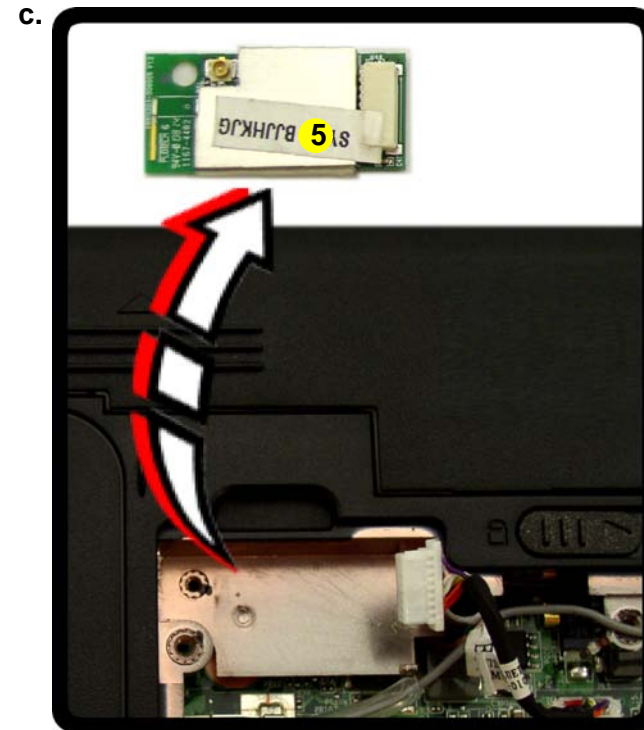
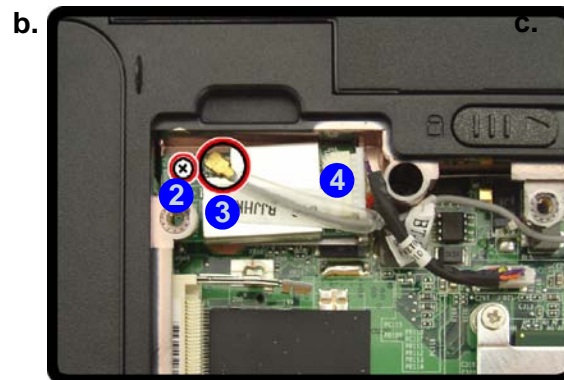
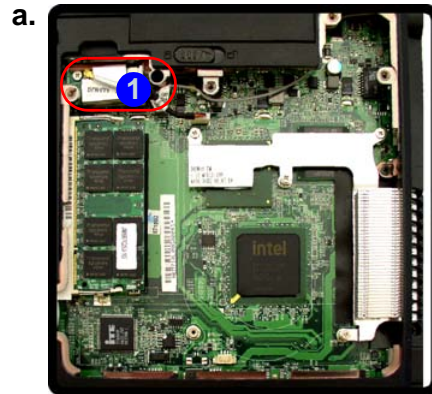

5. Bluetooth Module

- 1 Screw

Removing the Optical (CD/DVD) Device

1. Turn off the computer, remove the battery ([page 2 - 5](#)), and the CPU/RAM bay cover ([page 2 - 8](#)).
2. Remove the screw at point ①, and use a screwdriver to carefully push out the optical device at point ②.
3. Insert the new device and carefully slide it into the computer (the device only fits one way. DO NOT FORCE IT; The screw holes should line up).
4. Restart the computer to allow it to automatically detect the new device.

Figure 9
Optical Device Removal

- a. Remove the cover and locate the screw.
- b. Remove the screw and push the optical device out off the computer at point 2 and remove the optical device.



3. Optical Device

- 1 Screw

Disassembly

Figure 10
Keyboard Removal

- Press the three latches to release the keyboard.
- Lift the keyboard up and disconnect the cable from the locking collar.
- Remove the keyboard.

Removing the Keyboard

- Turn **off** the computer, and remove the battery ([page 2 - 5](#)).
- Press the **three** keyboard latches at the top of the keyboard to elevate the keyboard from its normal position (you may need to use a small screwdriver to do this).
- Carefully lift the keyboard up, being careful not to bend the keyboard ribbon cable ([Figure b](#)).
- Disconnect the keyboard ribbon cable **4** from the locking collar socket **5**.
- Carefully lift up the keyboard **6** ([Figure c](#)) off the computer.

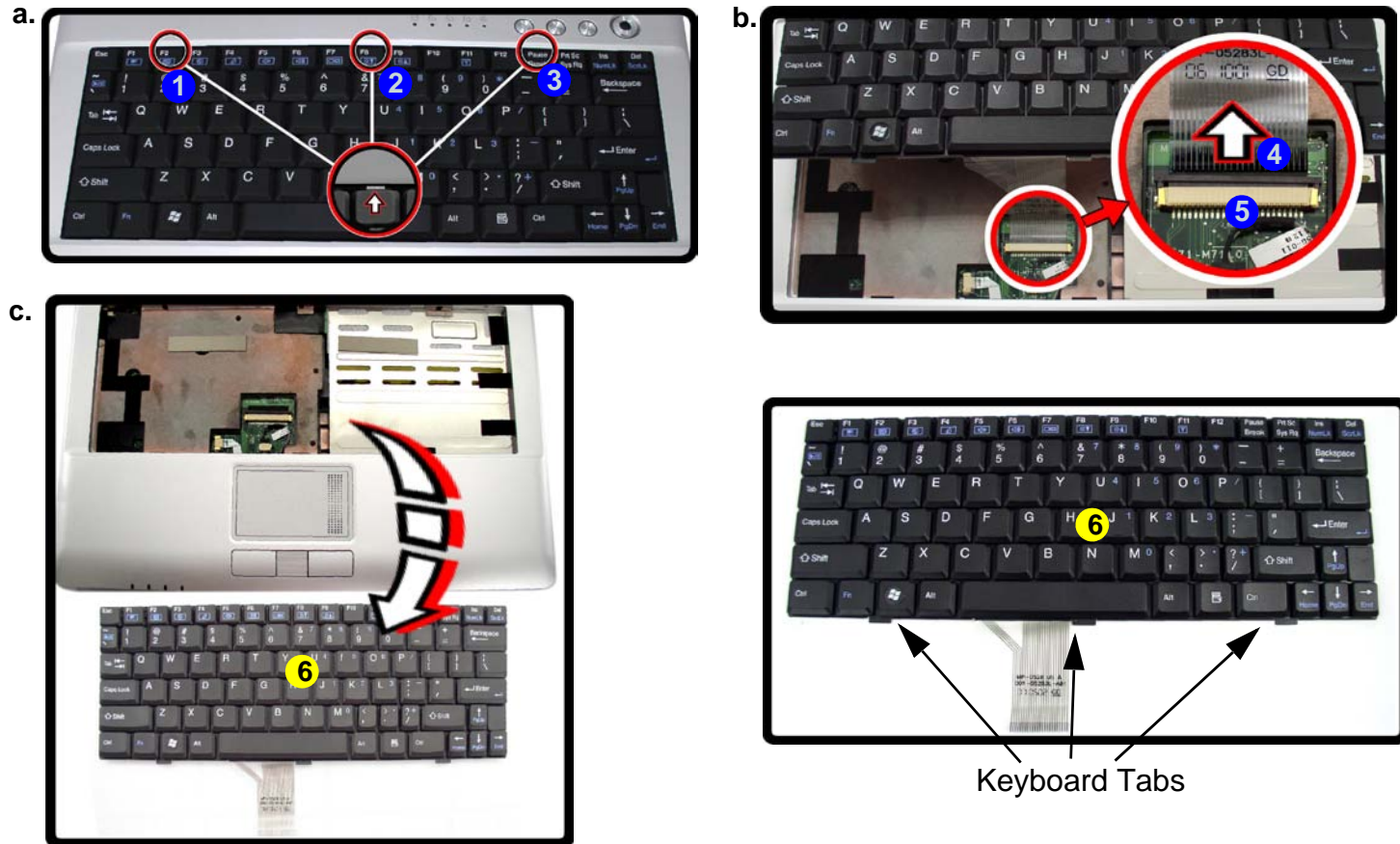

Re-Inserting the Keyboard

When re-inserting the keyboard firstly align the **three** keyboard tabs at the bottom of the keyboard with the slots in the case.



6. Keyboard Module.

Removing the Modem Module

1. Turn off the computer, remove the battery ([page 2 - 5](#)) and the CPU/RAM bay cover ([page 2 - 8](#)) and the heat sink ([page 2 - 10](#)) and the Wireless LAN ([page 2 - 11](#)) and the optical device ([page 2 - 13](#)) and the keyboard ([page 2 - 14](#)).
2. Disconnect the connectors **1** - **2** from under the keyboard and turn it over.
3. Remove screws **3** - **4** from the rear of the computer.

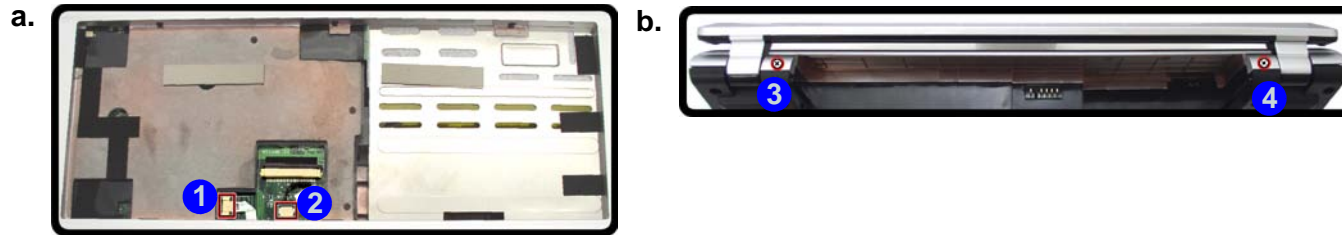
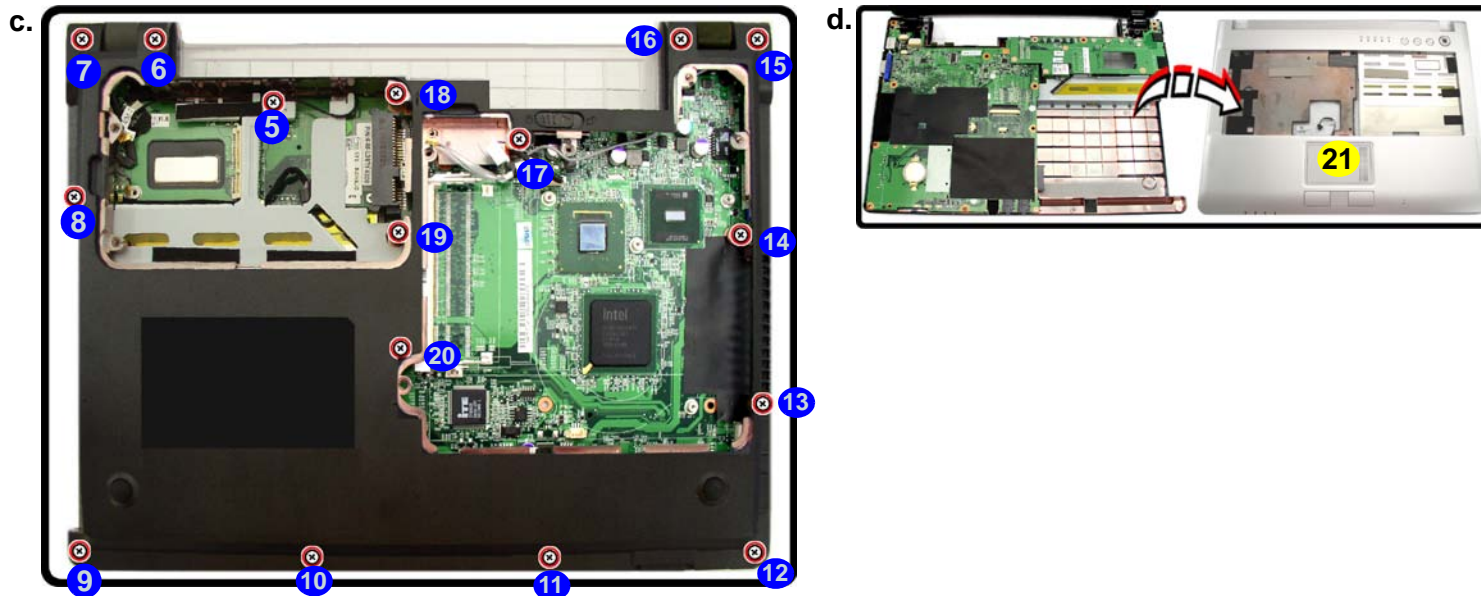



Figure 11
Modem Removal

- a. Disconnect the connectors from under the keyboard.
- b. Remove the screws.
- c. Remove the screws.
- d. Remove the top case.

4. Remove the screws **5** - **20** from the bottom case.
5. Carefully lift up the top case **21** off the computer.





21. Top Case

- 18 Screws

Disassembly

Figure 12 Modem Removal Sequence

- e. Remove the screws and disconnect the connectors.
- f. Separate the bottom case from the main board.
- g. Remove the screws
- h. Lift the modem up off the socket and disconnect the connector.

6. Remove screws 22 - 24 and disconnect the connectors 26 - 27 from the mainboard.
7. Separate the bottom case 28 from the mainboard 29 and turn it over.
8. Remove the screws 30 - 31.
9. Lift the modem 32 up off the socket 33 and disconnect the connector 34 from the modem.

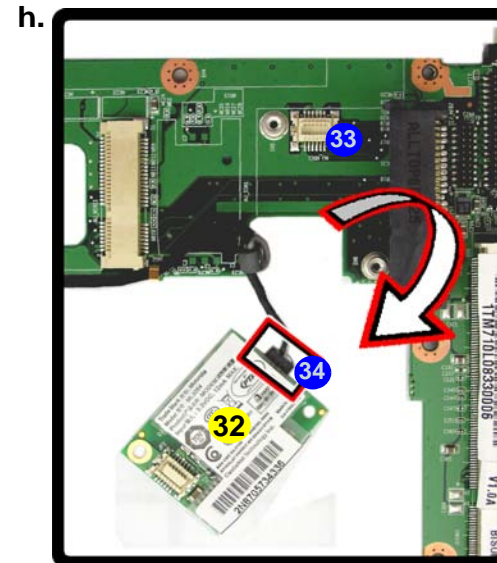
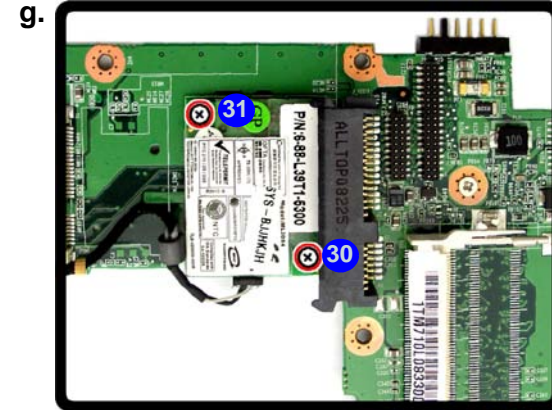
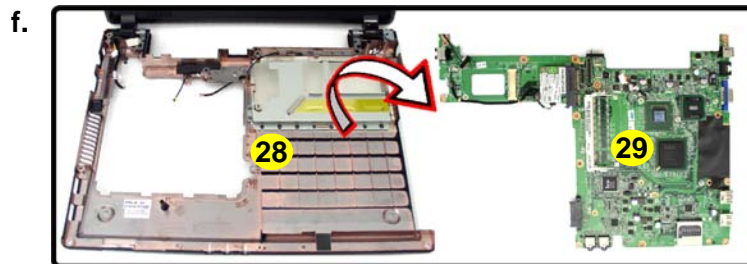
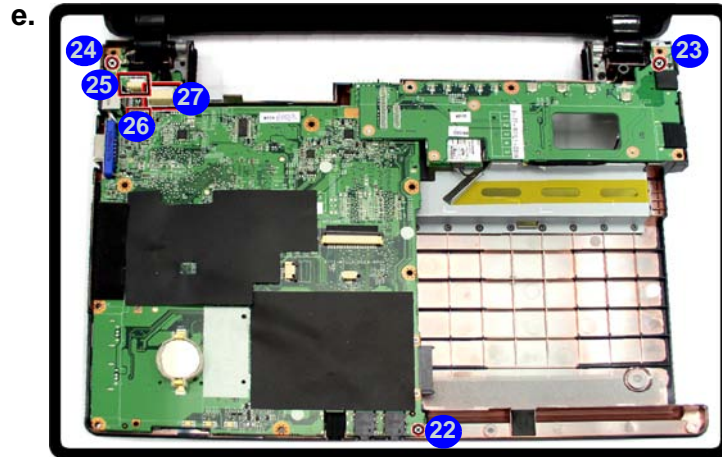

28. Bottom Case
29. Main Board
32. Modem

- 5 Screws

Appendix A:Part Lists

This appendix breaks down the *M710L* series notebook's construction into a series of illustrations. The component part numbers are indicated in the tables opposite the drawings.

Note: This section indicates the *manufacturer's* part numbers. Your organization may use a different system, so be sure to cross-check any relevant documentation.

Note: Some assemblies may have parts in common (especially screws). However, the part lists DO NOT indicate the total number of duplicated parts used.

Note: Be sure to check any update notices. The parts shown in these illustrations are appropriate for the system at the time of publication. Over the product life, some parts may be improved or re-configured, resulting in *new* part numbers.

Part List Illustration Location

The following table indicates where to find the appropriate part list illustration.

Table A - 1
Part List Illustration
Location

Part	Pages#
Top	<i>page A - 3</i>
Bottom	<i>page A - 4</i>
LCD	<i>page A - 5</i>
HDD	<i>page A - 6</i>
Combo	<i>page A - 7</i>
DVD-Combo	<i>page A - 8</i>

Top

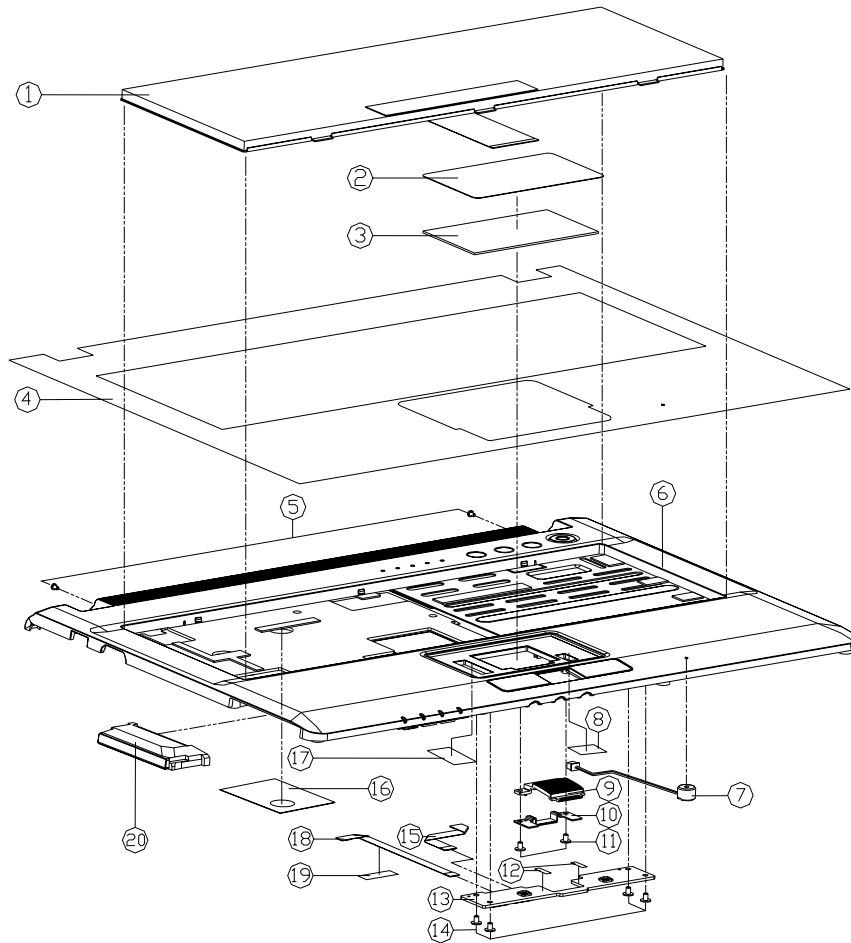

Figure A - 1
Top

ITEM	PART NAME	PART NO	REMARK
1	M/B USA MP-02283US-4303 M7205	6-80-M7250-011-1	
2	TOUCH PAD MYLAR RB35 M7205	6-40-M7252-011	
3	TOUCH PAD TMSIPBZIR389 M660JE	6-49-M66E2-010	
4	TOP CASE PROTECT MYLAR (411910) M7205	6-40-M7212-022	
5	WASHER SCREW M2X2L KI NI ICT	6-35-B1120-3R0	
6	TOP CASE MIDDLEKX FLOATING M7207	6-39-M7212-011	
7	NEOPRENE O-RING WITH 2X SYLUMI LAM KIK	6-23-EM55G-011	
8	TOUCH PAD GROUND AL FOLDED FOR CRAL	6-47-M55G2-010	
9	CP FINGER CENTER DAMY PC-ASGIC27AD M7205	6-42-M7252-041-1	
10	FINGER BRACKET MIDDLE M7205	6-33-M7252-201	
11	SCREW M2X2L KI NI ICT NY 028 14-01	6-35-B1120-3R5-1	
12	CLIP BUSH PLUR P020-02000000000000000000	6-40-M7295-011	
13	CLICK BOARD V1.0 M710L	6-77-M71L2-D01	
14	WASHER SCREW M2X2L KI NI ICT GY-PATCH	6-35-B1120-3RE	
15	ITC CABLE FOR TOUCH PAD TO M/B TOP M7205	6-43-M7250-010	
16	MYLAR FOR TOP CASE (354442) M7205	6-40-M72R2-020	
17	TOUCH PAD GROUND AL FOLDED FOR CRAL	6-47-M55G2-020	
18	ITC CABLE FOR CLCK TO M/B M7205	6-43-M7250-020	
19	TAPE MYLAR (C) MYLAR M550J	6-40-M55J2-030	
20	DUMMY NEW CARD RUBBER SILICONE M70L	6-47-M71L3-011	

A.Part Lists

Bottom

Figure A - 2
Bottom

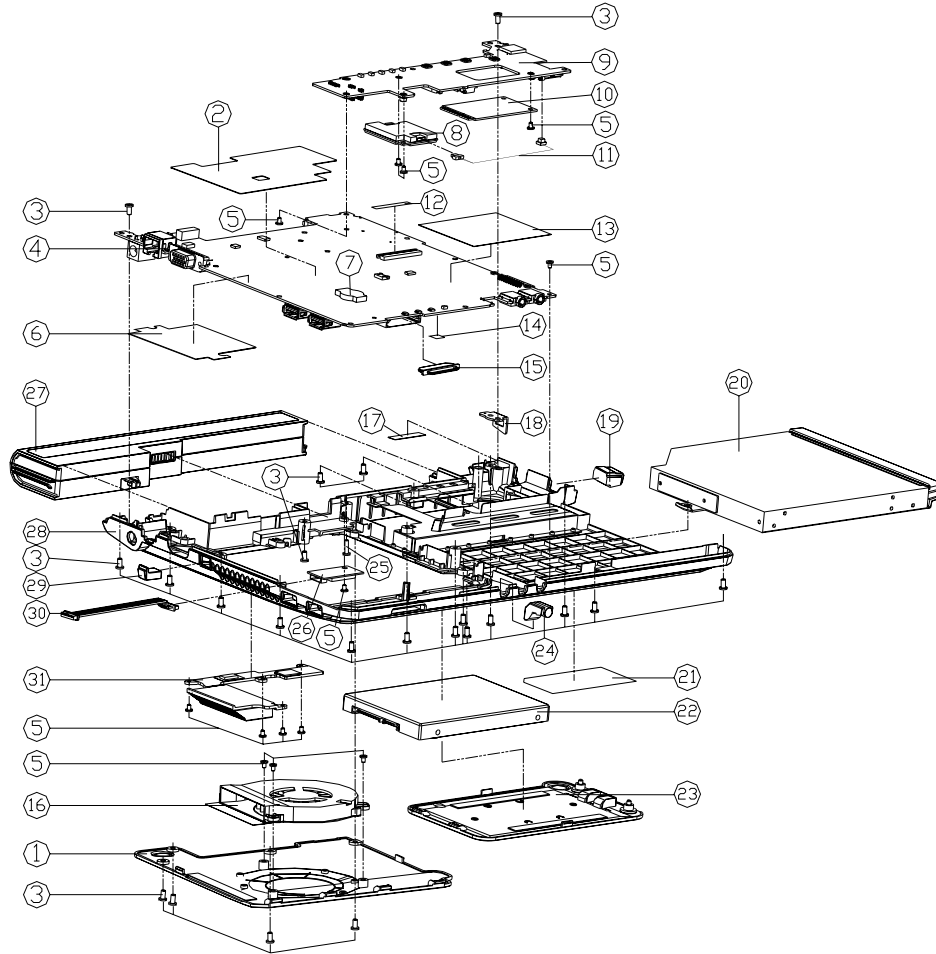

ITEM	PART NAME	PART NO	REMARK
1	CPU COVER MODULE(GADGET) M720S	6-42-M72SS-102	
2	MYLAR 2 FOR MB (944242851) FR83 M720S	6-40-M72SS-060	
3	SCREW M2.5x5L K1 BK/Z ICT NY	6-35-B6125-5RA	
4	MAIN BOARD V10A CW/ODD M710L	6-77-M71LO-001A-1	
4	MAIN BOARD V10A CW/ODD M710L	6-77-M71LO-001A	
5	SCREW M2x3L K1 NI ICT NY	6-35-B1120-3RA	
6	NORTH BRIDGE MYLAR FR83 M710L	6-40-M71LS-011	
7	BATTERY 3V 210MA CR2032 OHTSUBISHI	6-23-62015-607	
8	DATA MEMORY MODULE 2 GB M710L (OPTION)	6-88-L39T1-5300	
8	DATA MEMORY MODULE 4 GB M710L (OPTION)	6-88-M76S1-8110	
9	MULTI I/O BOARD V10A M710L	6-77-M71L1-001A	
10	WIRE CABLE FOR RJ-11 TO HDX 2P M720S	6-88-MSS52-7000	<OPTION>
11	WIRE CABLE FOR RJ-11 TO HDX 2P M720S	6-43-M72SU-010	<OPTION>
12	MS20G K/B CONN MYLAR	6-40-M52G5-060	
13	PHONE JACK MYLAR FOR83+HEADSET M720S	6-40-M72SS-031	
14	PROTECT MB MYLAR FR83 M720S	6-40-M72SS-040	
15	MS20G CARD READER RUBBER	6-47-M52G8-010	
16	FAN MODULE M720	6-31-M72SS-104	
17	SPEAKER CABLE PASTE (FR83+0810) M720S	6-40-M72S3-010	
18	LOCK BRACKET SECC M720S	6-33-M72S3-010	
19	SILICONE RUBBER FOR USB H70 M710L	6-47-M71L3-031	
20	SATA DVD SUPER MULTI ASS'Y M710L	6-79-M710L000-000	
20	SATA DVD COMBO ASS'Y M710L	6-79-M710L00X-000	
20	DUMMY ODD MODULE M710L	6-42-M71LZ-102	
21	PRODUCT LABEL FOR M710L	6-45-M71L3-010	
22	W/O HDD ASS'Y M720S	6-79-M72SJ-010	
23	HDD COVER MODULE M720S	6-42-M72SJ-103	
24	DUMMY SPIND RUBBER SILICONE M710L	6-47-M71L3-022	
25	SCREW M2x4L K1 BK/Z ICT NY	6-35-B6120-8R0	
26	BLUETOOTH 2.0 FOR MODULE (OPTION GREEN LINE) M720S	6-88-M55J5-620	<OPTION>
26	BLUETOOTH 2.0 FOR MODULE (OPTION GREEN LINE) M720S	6-88-M62C5-390	<OPTION>
26	BLUETOOTH 2.0 FOR MODULE (OPTION GREEN LINE) M720S	6-88-M73T5-3900	<OPTION>
27	MAP 5111 (M720S) 2P 3P M720S	6-87-M71LS-4CT	
27	MAP 5111 (M720S) 2P 3P M720S	6-87-M720S-4M4	
27	MAP 5111 (M720S) 2P 3P M720S	6-87-M720S-4M4	
27	MAP 5111 (M720S) 2P 3P M720S	6-87-M72SS-4DF2	
28	BOTTOM CASE MODULE (GROSS) M720S	6-39-M72S3-018	
29	1394 RUBBER M720S	6-47-M72SP-010	
30	WIRE CABLE FOR BLUETOOTH TO M/B OF M720S	6-43-M72SB-010	
31	CPU THERMAL MODULE M710L	6-31-M71LS-101	

LCD

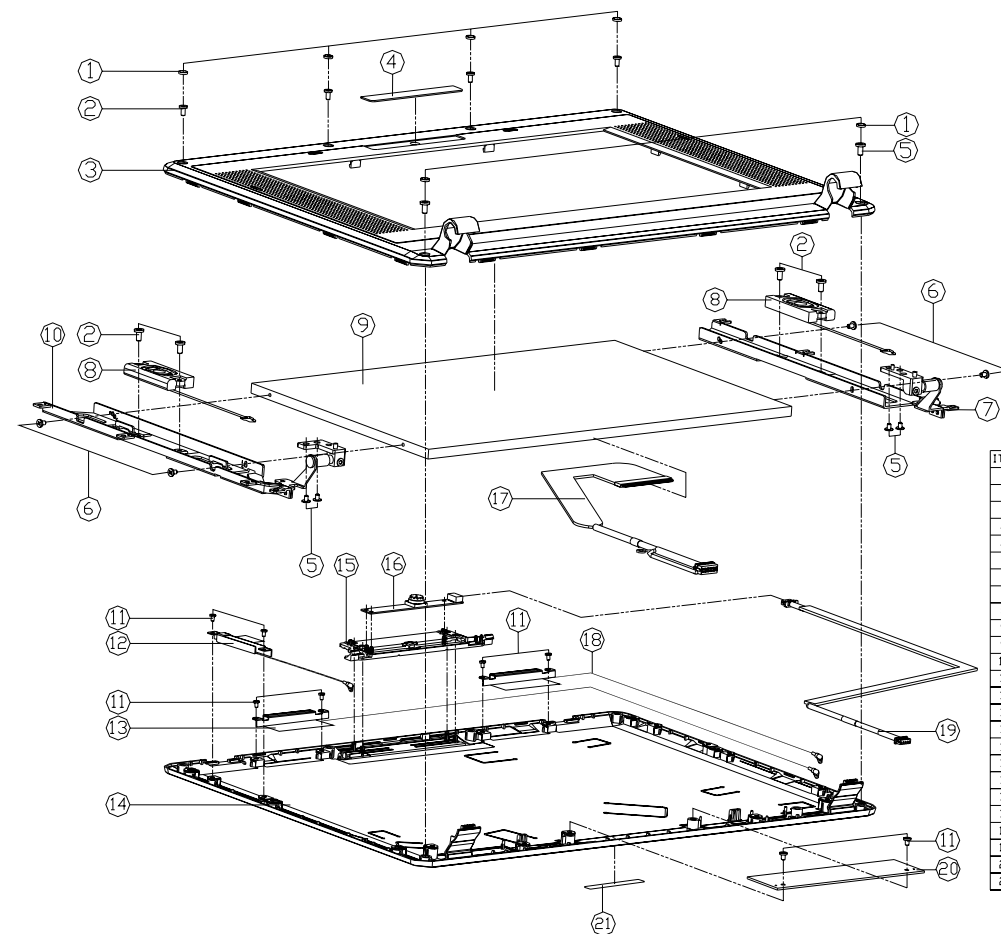

Figure A - 3
LCD

ITEM	PART NAME	PART NO	REMARK
1	LCD FRONT COVER SOREY HOLE RUBBER W/OS	6-47-M72S1-021	
2	SOREY NENAL I RT ICT GY-PATCH (T-88 3-4)	6-35-C6120-4RB	
3	LCD FRONT COVER MODULE M710L	6-39-M71L1-012	
4	CCD LINES (PMMA) M740S	6-42-M74S1-010	
4	CCD LINES (FR700) M740S	6-42-M74S1-020	
5	SCREW M2.5XSL K1 BK/Z ICT NY	6-35-B6125-SRA	
6	SCREW NENSL KI BK/Z ICT W/OS T-83	6-35-B6120-2RB	
7	LCD HINGE R SECC M710L	6-33-M71L1-012	
8	SPEAKER MODULE 15W BY 00-2534803 M710L	6-23-5M71L-010	
9	LED BL' YVGA OPT LAMENWAKY LED SSM	6-50-ED255-C00	FDR CPT
9	LED BL' YVGA LMDLX ATTENMR LED SSM	6-50-ED255-V00	FDR LNNGLUX
10	LCD HINGE L SECC M710L	6-33-M71L1-022	
11	NOT FOR ASSEMBLY NENSL KI W ICT GY-PATCH	6-35-B1120-3RE	
12	ANTENNA ALU/STN 240SG PRA BY 00-2534803 M710L	6-23-7M72S-020	(OPTION)
13	ANTENNA ALU/STN 240SG PRA BY 00-2534803 M710L	6-23-7M72L-012	
14	LCD BACK COVER MODULE M710L	6-39-M71L1-022	
15	CAMERA HOLD MODULE M710L	6-42-M71L1-101	
16	IVE CAMERA BRSH FIX BR28M57-80 1.5M W/AT	6-88-M740C-4922	(OPTION)
16	IVE CAMERA BRSH FIX BR28M57-80 2M W/AT	6-88-M740C-4913	(OPTION)
17	WIRE CABLE SPIN W/B TO CPT LCD M710L	6-43-M71L1-021	FDR CPT
17	WIRE CABLE SPIN W/B TO LMDLX LCD M710L	6-43-M71L1-011	FDR LNNGLUX
18	ANTENNA ALU/STN 240SG PRA BY 00-2534803 M710L	6-23-7M72L-022	(OPTION)
19	WIRE CABLE SPIN W/B TO CCD M710L	6-43-M71L1-012	
20	LCD BACK COVER PLATE PRA M710L	6-40-M71L1-012	
21	FDR M540G (FDR LOGO STYLE-NOTE)	6-45-M54G1-020	

A.Part Lists

HDD

Figure A - 4
HDD

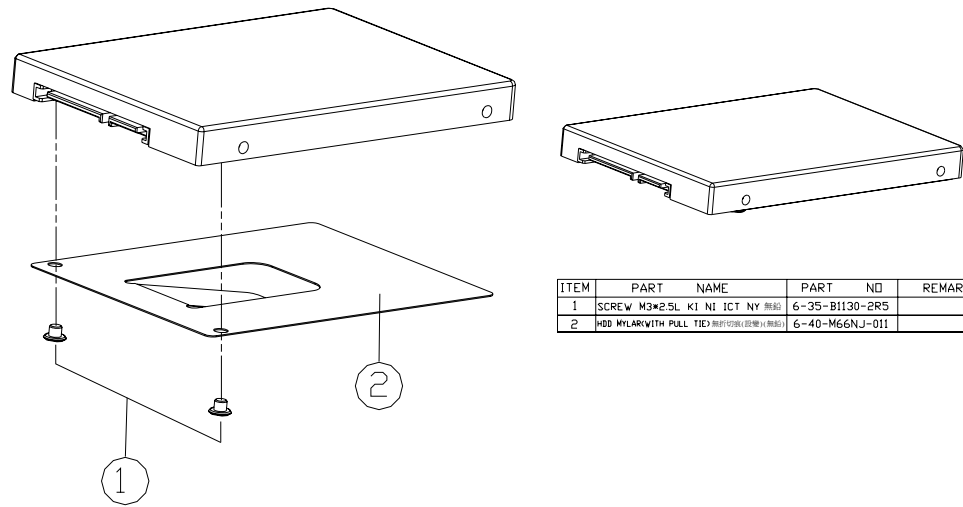

ITEM	PART NAME	PART NO	REMARK
1	SCREW M3*2.5L KI NI ICT NY <small>(PH06)</small>	6-35-B1130-2R5	
2	HDD MYLAR WITH PULL TIE <small>(HDD MYLAR WITH PULL TIE)</small>	6-40-M66NJ-011	

Combo

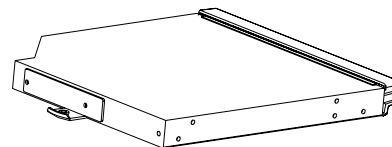
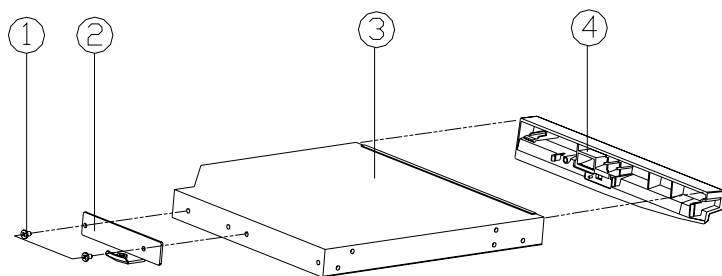

ITEM	PART NAME	PART NO	REMARK
1	SCREW M2x3L K1 NI ICT GTY-PATCH	6-35-B1120-3RE	
2	CD-ROM LOCK BRACKET SECC M720S	6-33-M72SZ-010	
3	SATA DVD COMBO 5 1/4" 24X/8X 12.7MM TSST	6-85-90724-T01	
3	SATA DVD COMBO 5 1/4" 24X/8X 12.7MM CR690	6-85-90724-C01	
4	COMBO G-BZEL MIDDLE (CR690/TSST) M720S (CP-48)	6-42-M72SX-102-1	

Figure A - 5
Combo

DVD-COMBO

Figure A - 6
DVD-COMBO

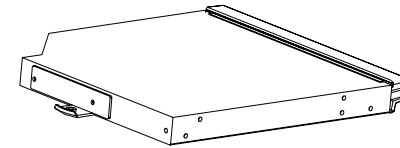
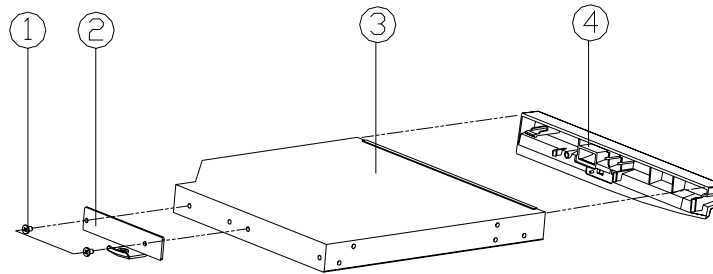

ITEM	PART	NAME	PART	NO	REMARK
1	SCREW	M2*3L K1 NI ICT GTY-PATCH	6-35-B1120-3RE		
2	CD-ROM LOCK BRACKET	SECC M720S	6-33-M72SZ-010		
3	SATA DVD COMBO	5 1/4" 24X/8X 12.7MM TSS1	6-85-90724-T01		
3	SATA DVD COMBO	5 1/4" 24X/8X 12.7MM EXK690	6-85-90724-C01		
4	COMBO G-BEZEL MODULE	(M720S/M720S) M720S (M720S)	6-42-M72SX-102-1		

Appendix B:Schematic Diagrams

This appendix has circuit diagrams of the *M710L* notebook's PCB's. The following table indicates where to find the appropriate schematic diagram.

Diagram - Page	Diagram - Page	Diagram - Page
<i>SYSTEM BLOCK DIAGRAM - Page B - 2</i>	<i>CLOCK GENERATOR - Page B - 13</i>	<i>KBC-ITE IT8502E - Page B - 24</i>
<i>Diamondville SC 1/2 - Page B - 3</i>	<i>CH7-M 1/4, SATA - Page B - 14</i>	<i>3VS, 5VS - Page B - 25</i>
<i>Diamondville SC 2/2 - Page B - 4</i>	<i>ICH7-M 2/4, PCI, USB, SPI - Page B - 15</i>	<i>VDD3, VDD5 - Page B - 26</i>
<i>945GSE 1/5, HOST - Page B - 5</i>	<i>ICH7-M 3/4 - Page B - 16</i>	<i>POWER 1.8V/ 0.9V - Page B - 27</i>
<i>945GSE 2/5 - Page B - 6</i>	<i>ICH7-M 4/4 - Page B - 17</i>	<i>POWER 1.5VS/ 1.05VS - Page B - 28</i>
<i>945GSE 3/5, DDR - Page B - 7</i>	<i>MULTI I/O, ODD, CCD BT - Page B - 18</i>	<i>VCORE - Page B - 29</i>
<i>945GSE 4/5 - Page B - 8</i>	<i>NEW CARD, USB - Page B - 19</i>	<i>AC IN, CHARGE - Page B - 30</i>
<i>945GSE 5/5 - Page B - 9</i>	<i>CARD READER JMB385 - Page B - 20</i>	<i>CLICK BOARD - Page B - 31</i>
<i>DDRII SO-DIMM 0 - Page B - 10</i>	<i>LED, FAN, PC BEEP, TP, FP - Page B - 21</i>	<i>Multi B'd, LID, LED, SW, USB - Page B - 32</i>
<i>DDRII SO-DIMM 1 - Page B - 11</i>	<i>PCI-E LAN RTL8102E - Page B - 22</i>	<i>Multi B'd, Mini Card, MDC, RJ11 - Page B - 33</i>
<i>PANEL, INVERTER, CRT - Page B - 12</i>	<i>AUDIO CODEC ALC269 QFN - Page B - 23</i>	

Table B - 1
**Schematic
Diagrams**



Version Note

The schematic diagrams in this chapter are based upon version 6-7P-M71L3-003. If your mainboard (or other boards) are a later version, please check with the Service Center for updated diagrams (if required).

SYSTEM BLOCK DIAGRAM

Sheet 1 of 32
SYSTEM BLOCK
DIAGRAM

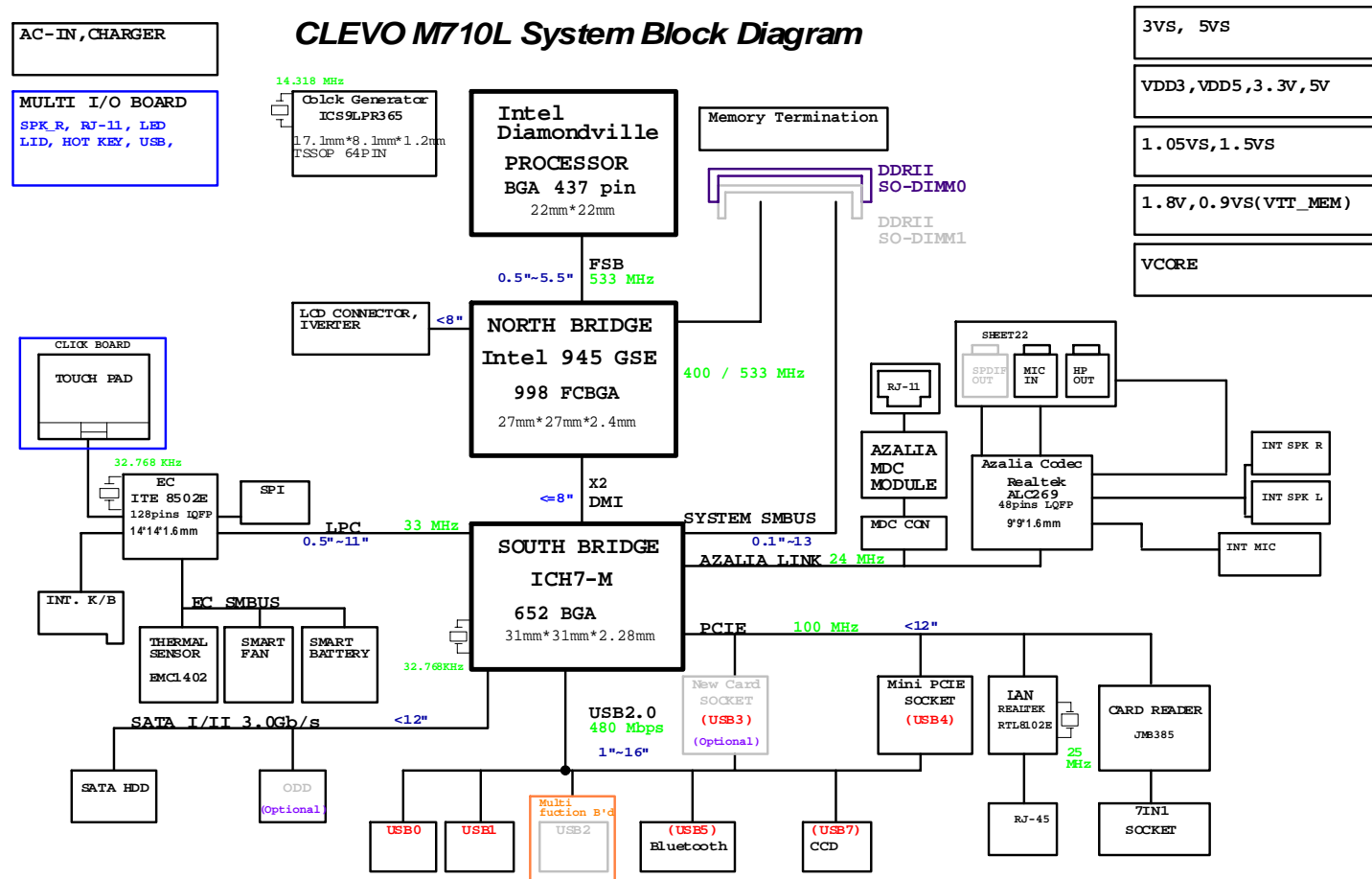

Diamondville SC 2/2

Sheet 3 of 32
Diamondville SC 2/2

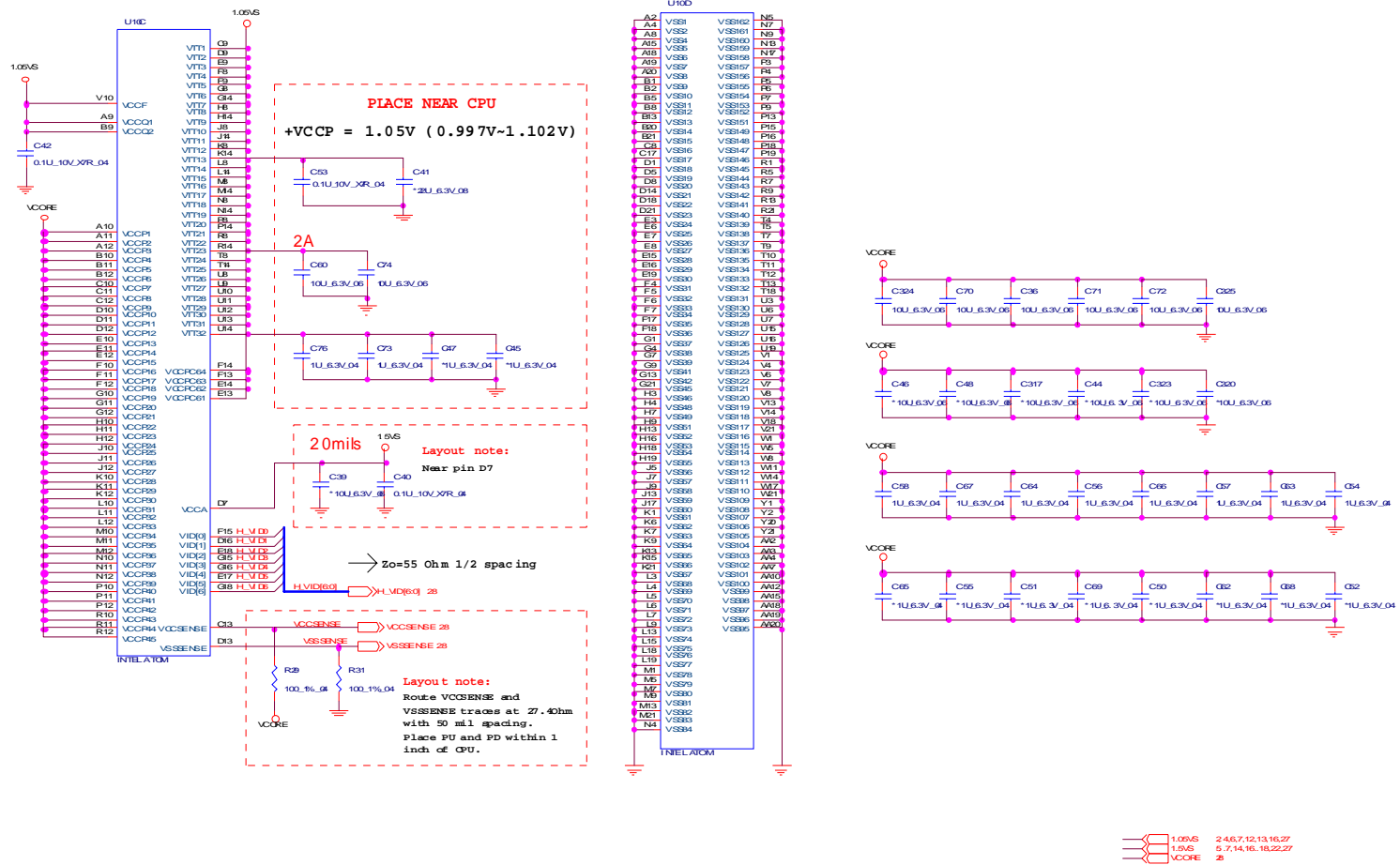

945GSE 1/5, HOST

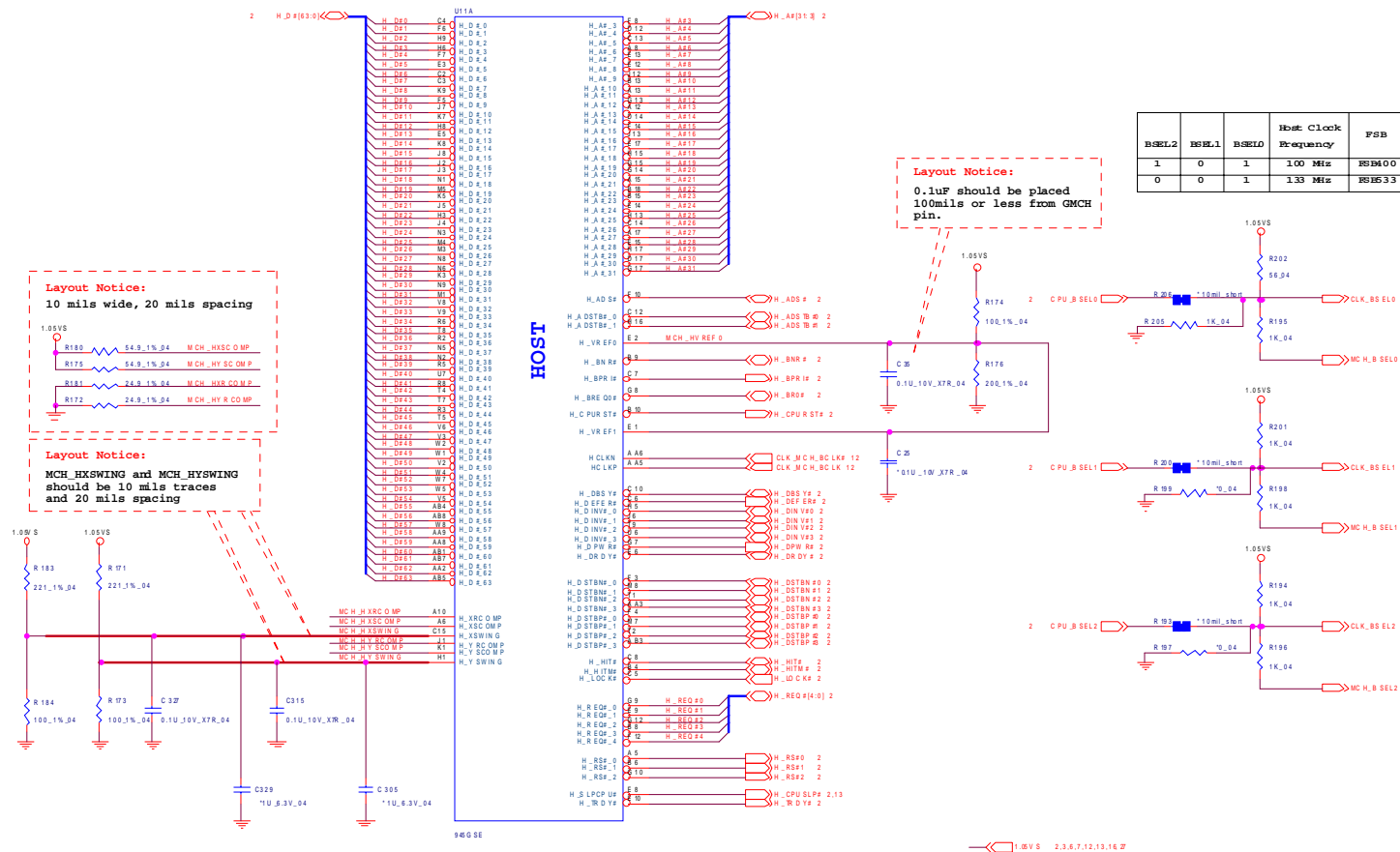

Sheet 4 of 32
945GSE 1/5, HOST

945GSE 2/5

Sheet 5 of 32
945GSE 2/5

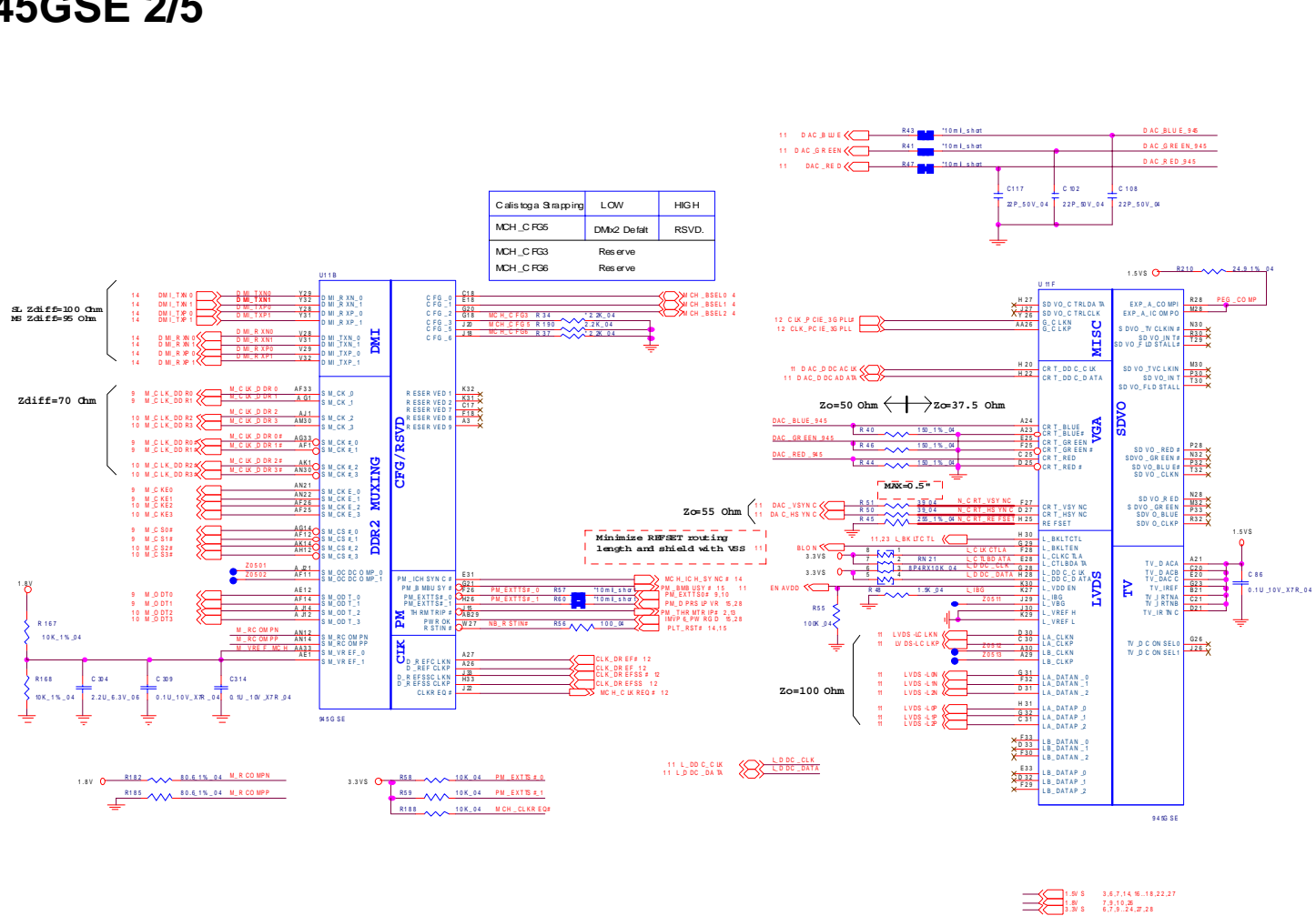

945GSE 3/5, DDR

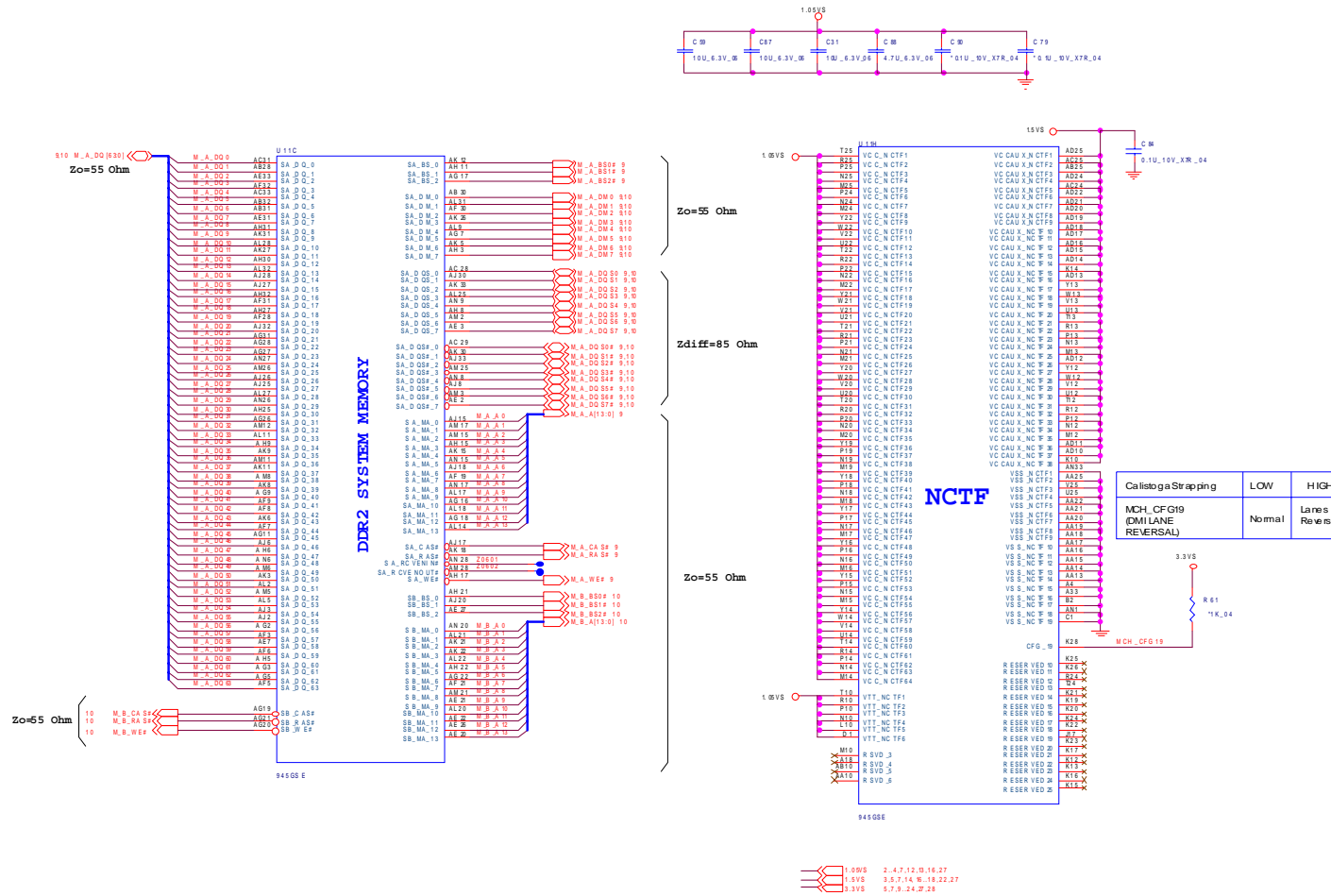

Sheet 6 of 32
945GSE 3/5, DDR

B. Schematic Diagrams

945GSE 4/5

Sheet 7 of 32
945GSE 4/5

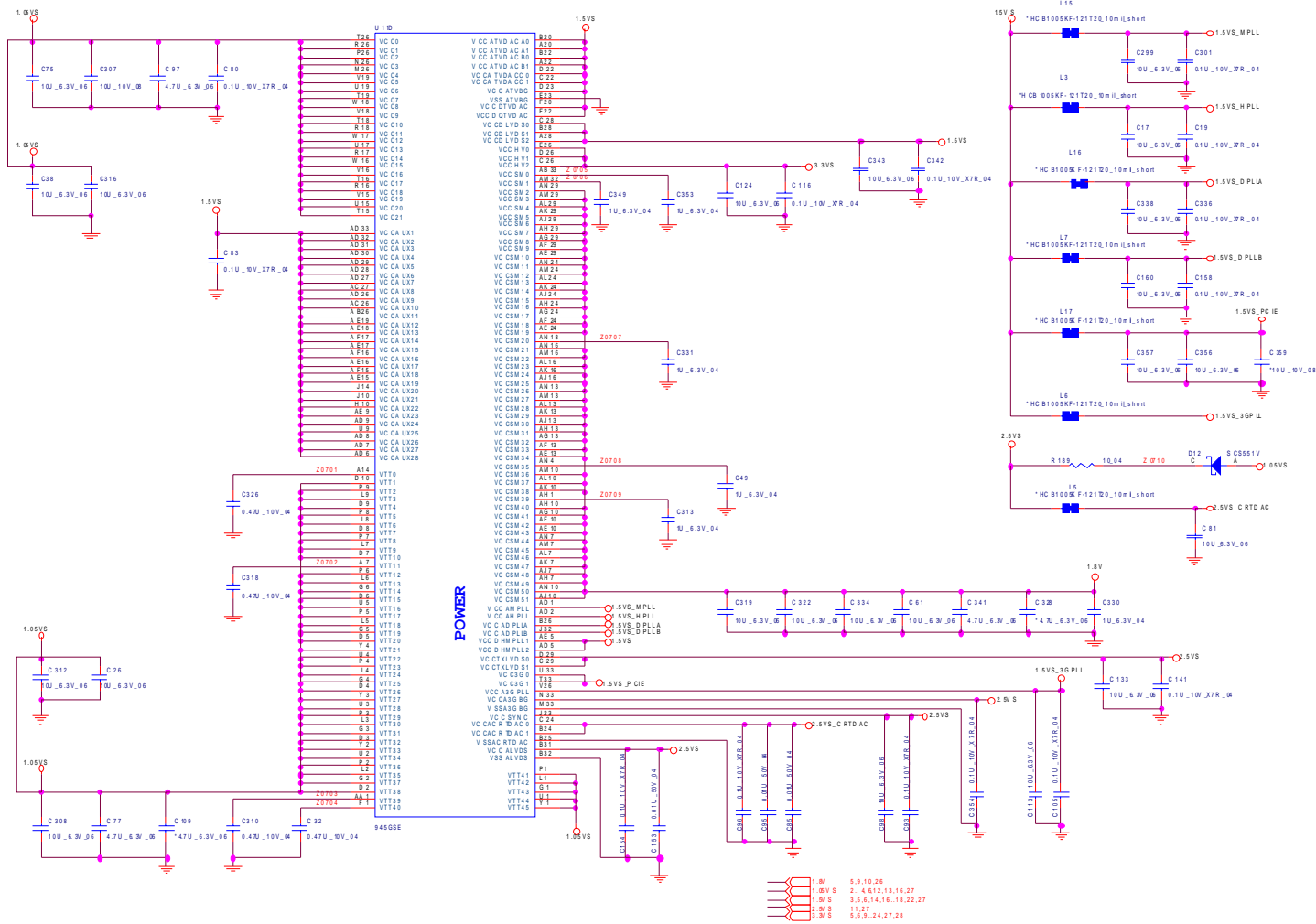

945GSE 5/5

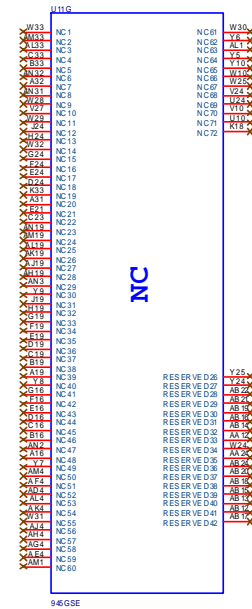
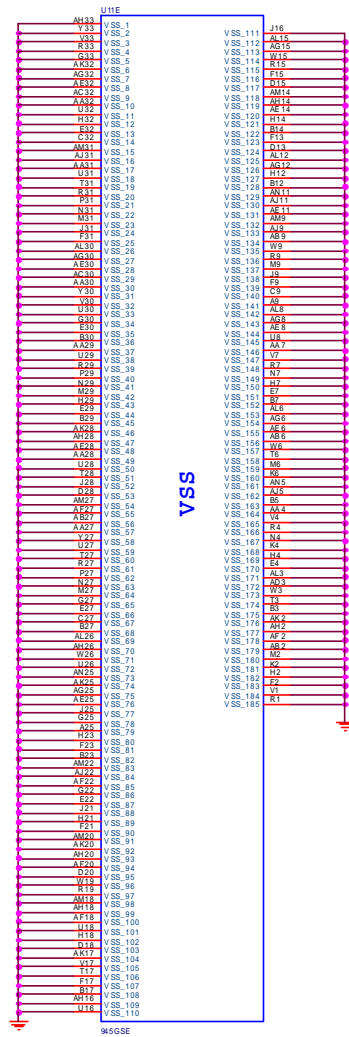

Sheet 8 of 32
945GSE 5/5

B. Schematic Diagrams

DDRII SO- DIMM 1

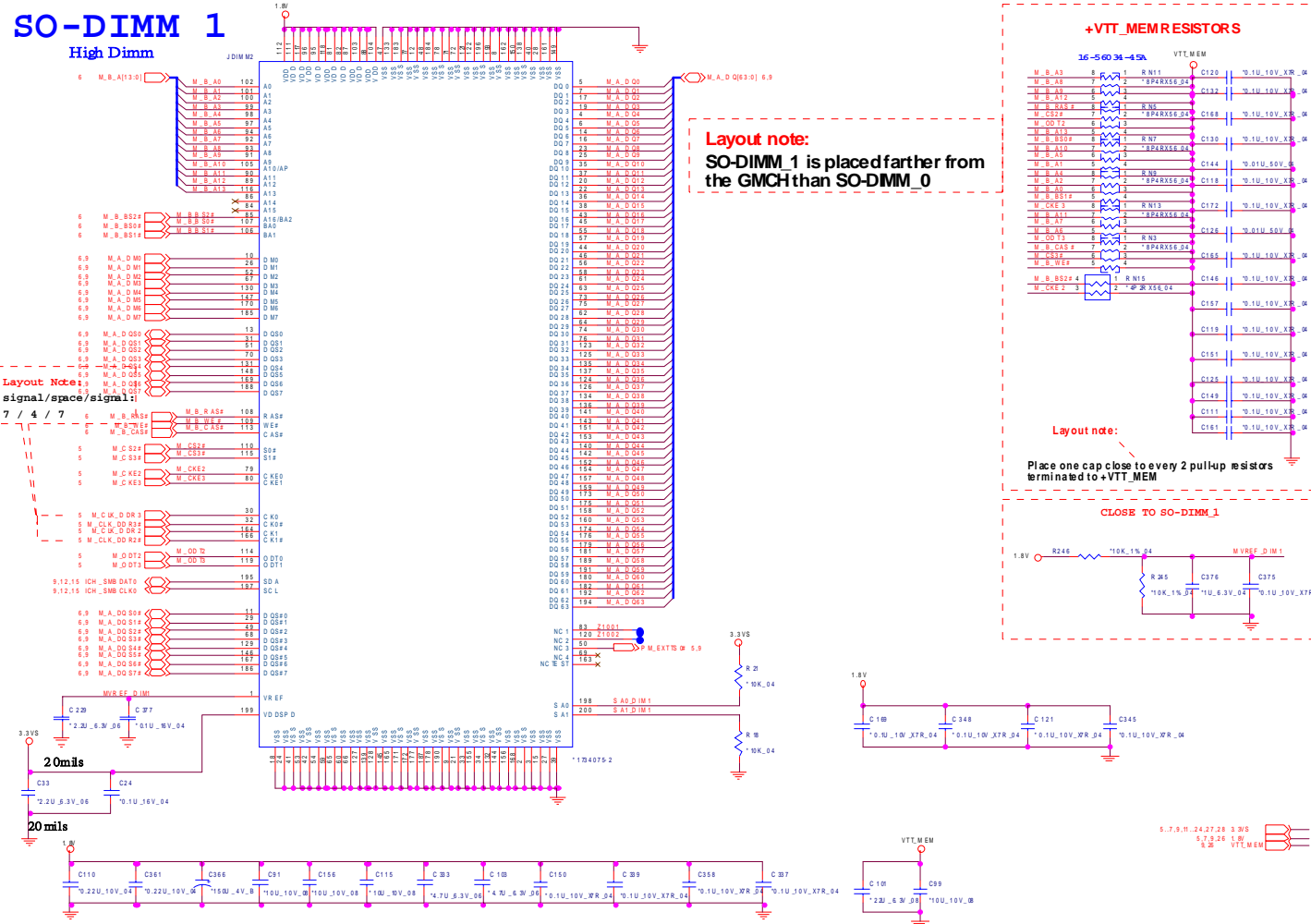

Sheet 10 of 32
DDRII SO-DIMM 1

CH7-M 1/4, SATA

Sheet 13 of 32
CH7-M 1/4, SATA

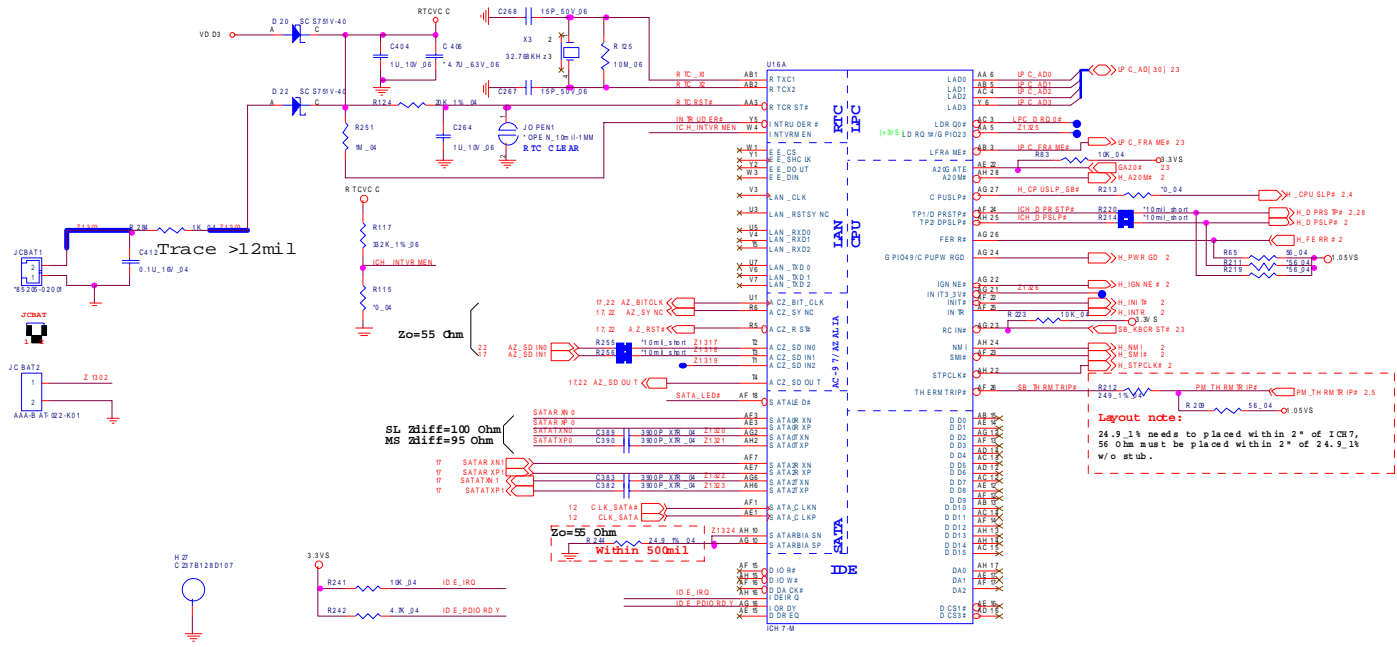

SATA HDD

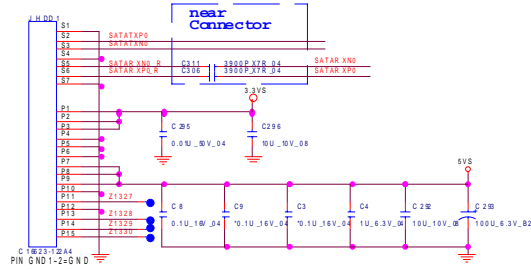

SATA HDD & ODD LED

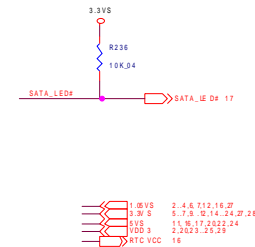

ICH7-M 2/4, PCI, USB, SPI

Layout Guide:
Near ICH7M
PBT_RST# : N/B, IDE, KBC, LAN
BUF_PLT_RST# : MINI CARD

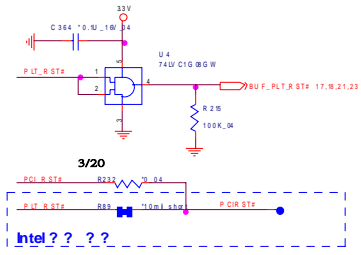
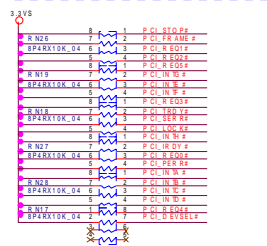

SL Zdiff=100 Ohm
MS Zdiff=95 Ohm

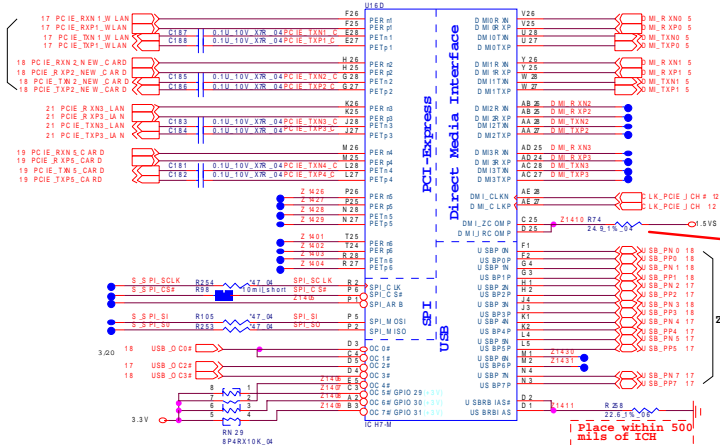

Place within 500 mils of ICH

- USB0: PORT0 on daughter board
- USB1: PORT1 on daughter board
- USB2: PORT2 on board
- USB3: NEW CARD
- USB4: Mini PCIE
- USB5: Bluetooth
- USB6: X
- USB7: CCD

Zo=90 Ohm

Zo=60 Ohm

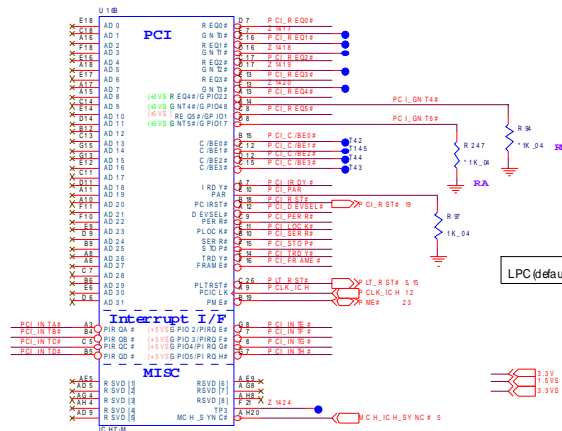

ICH7 Boot BIOS select			
Strap	GN T5#	RA	GN T4#
LPC (default)	11	UnStuf	Unst4f

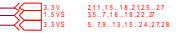

B.Schematic Diagrams

Sheet 14 of 32
ICH7-M 2/4, PCI,
USB, SPI

ICH7-M 3/4

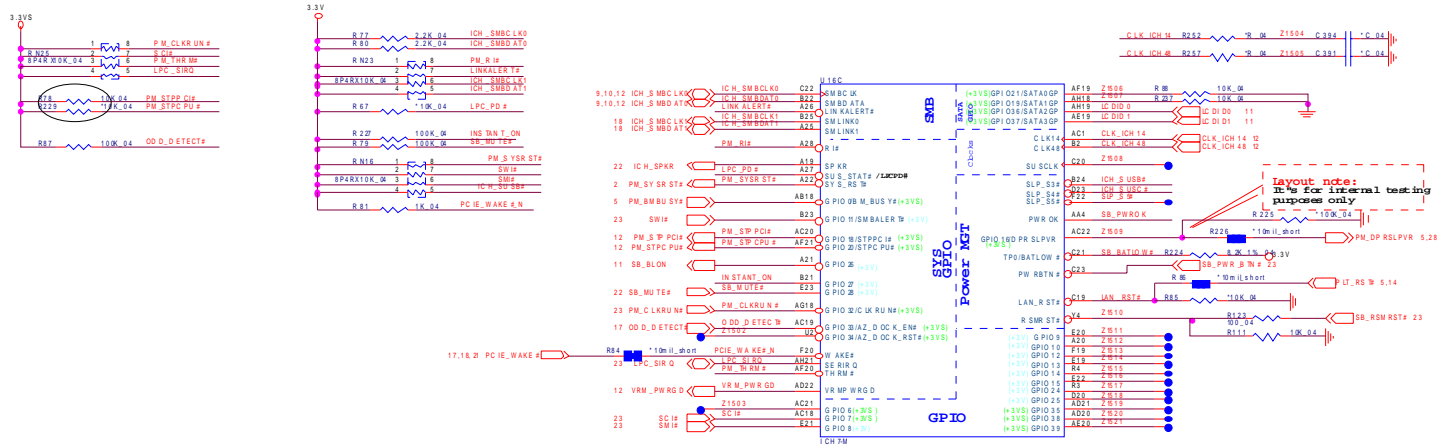

Layout note:
R# for internal testing purposes only

Sheet 15 of 32
ICH7-M 3/4

POWER GOOD

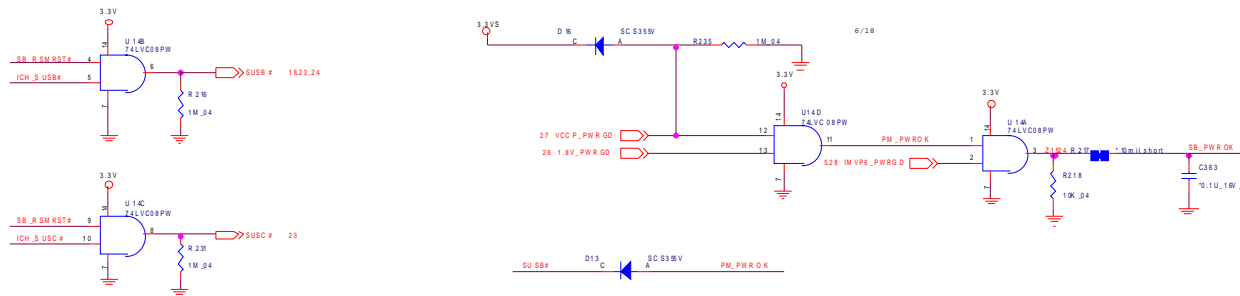

POWER OK

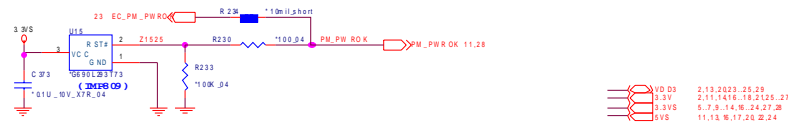

Signal	Value	Location
VO D3	2.13	2023, 25, 29
3.3V	2.11, 1.416, 18, 21, 55, 27	
3.3V	5, 7, 8, 14, 16, 24, 27, 28	
3.3V	11, 13, 16, 17, 20, 22, 24	

B.Schematic Diagrams

MULTI I/O, ODD, CCD BT

OPTION

SATA ODD

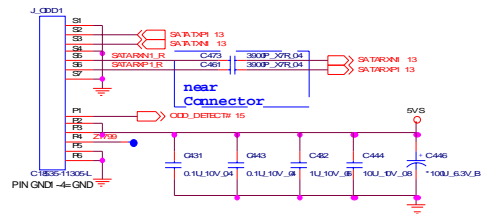

MULTI I/O CONN

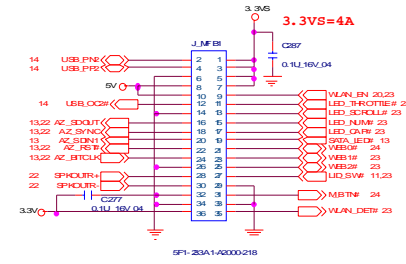

B.Schematic Diagrams

Sheet 17 of 32
MULTI I/O, ODD,
CCD BT

Bluetooth

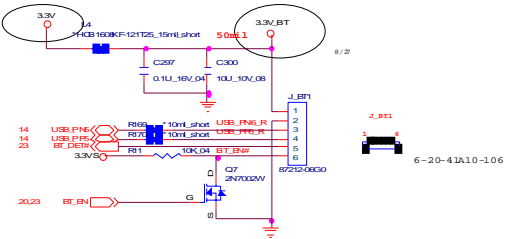

Port 5

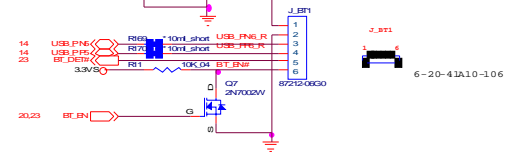

CCD

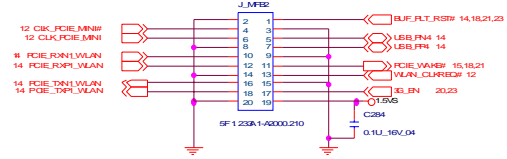
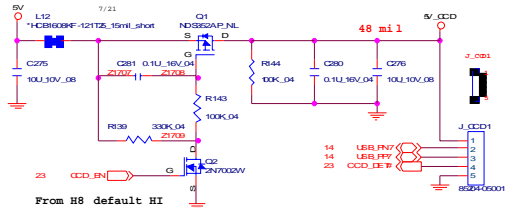

1.8V/S	3,5,7,14,16,18,22,27
3.3V	2,11,14,16,18,21,25,27
3.3V/S	5,7,8,8,8,24,27,28
5V	11,16,19,25,28
5V/S	11,13,16,20,22,24

CARD READER JMB385

Sheet 19 of 32
CARD READER
JMB385

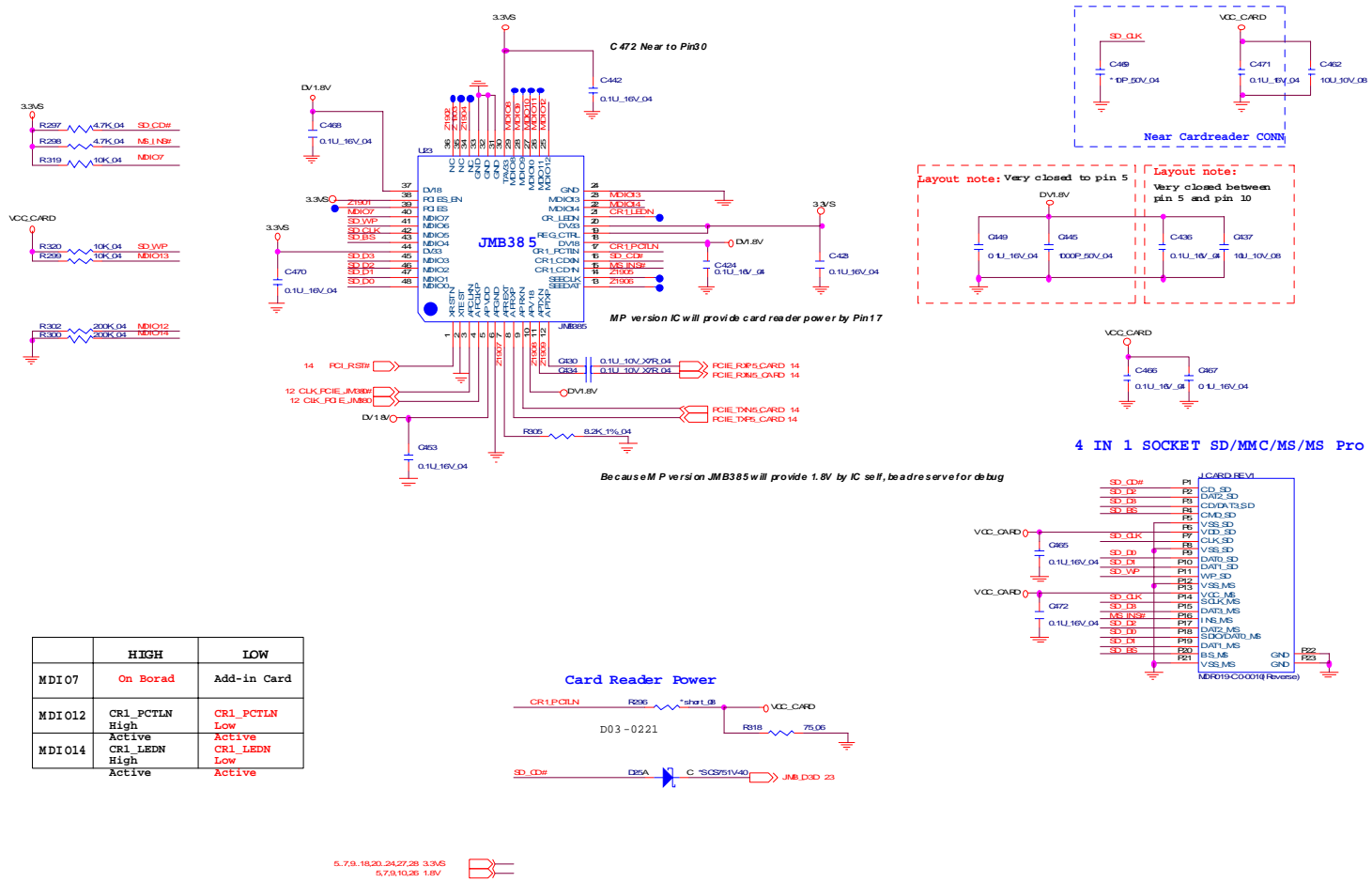

LED, FAN, PC BEEP, TP, FP

LED

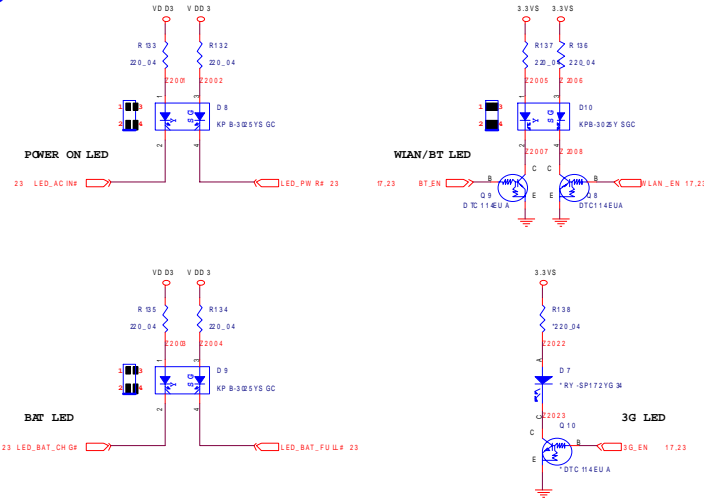

FAN CONTROL

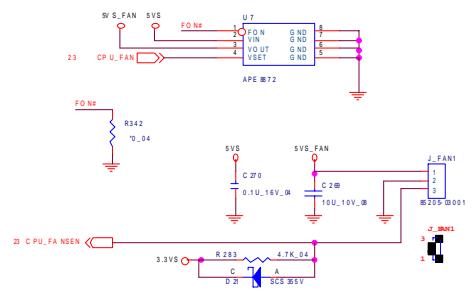

CLICK CONN

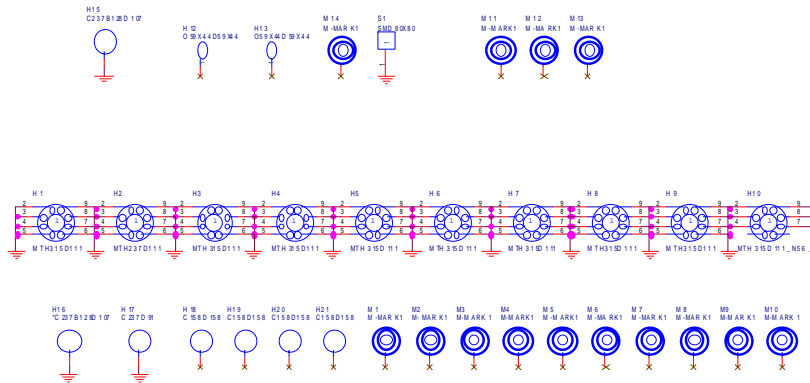
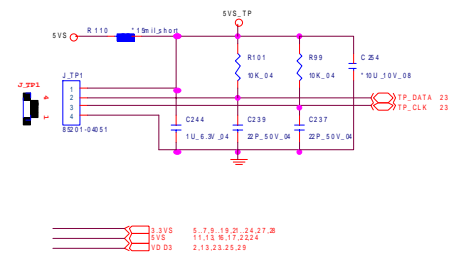

Sheet 20 of 32
LED, FAN, PC
BEEP, TP, FP

B.Schematic Diagrams

PCI-E LAN RTL8102E

LAN (RTL8102E)

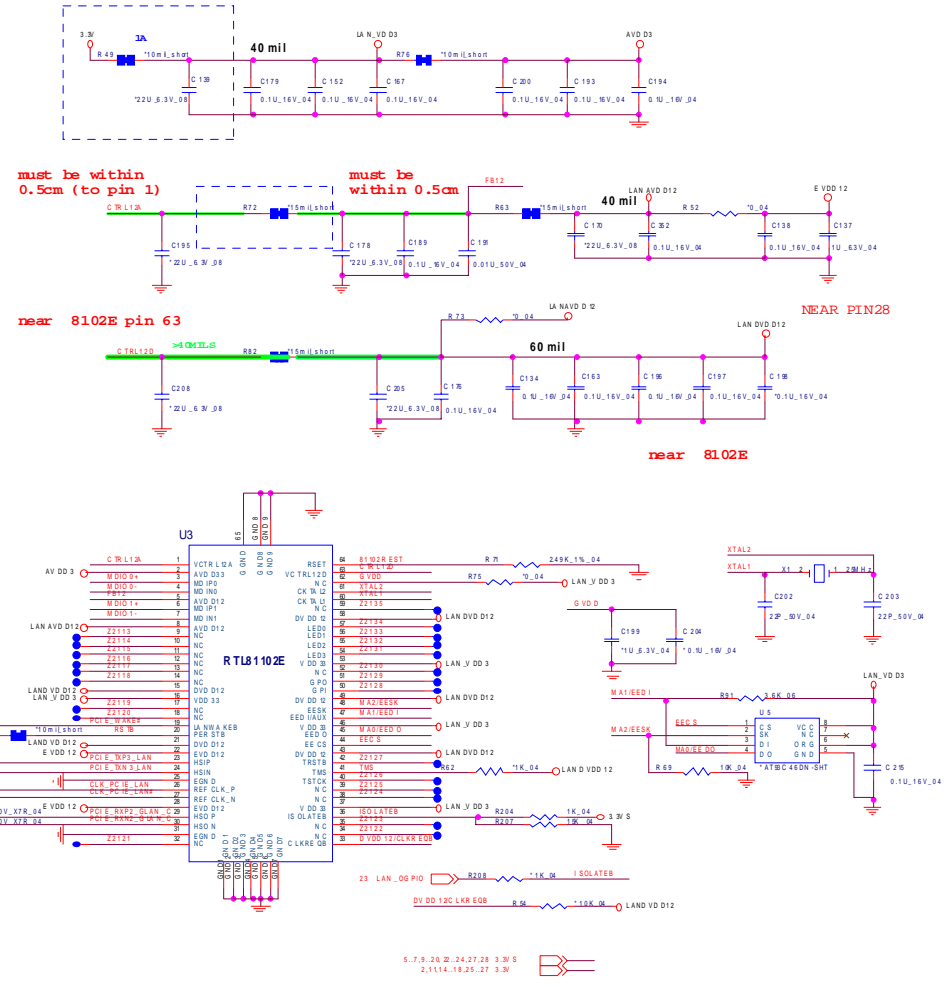
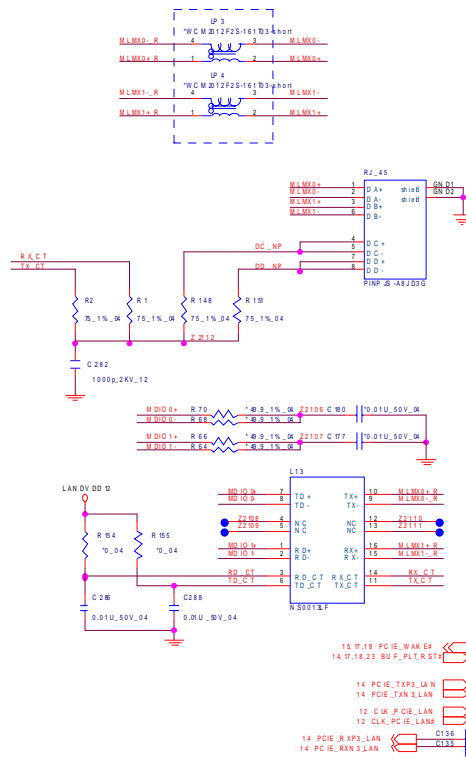

B.Schematic Diagrams

Sheet 21 of 32
PCI-E LAN
RTL8102E

3VS, 5VS

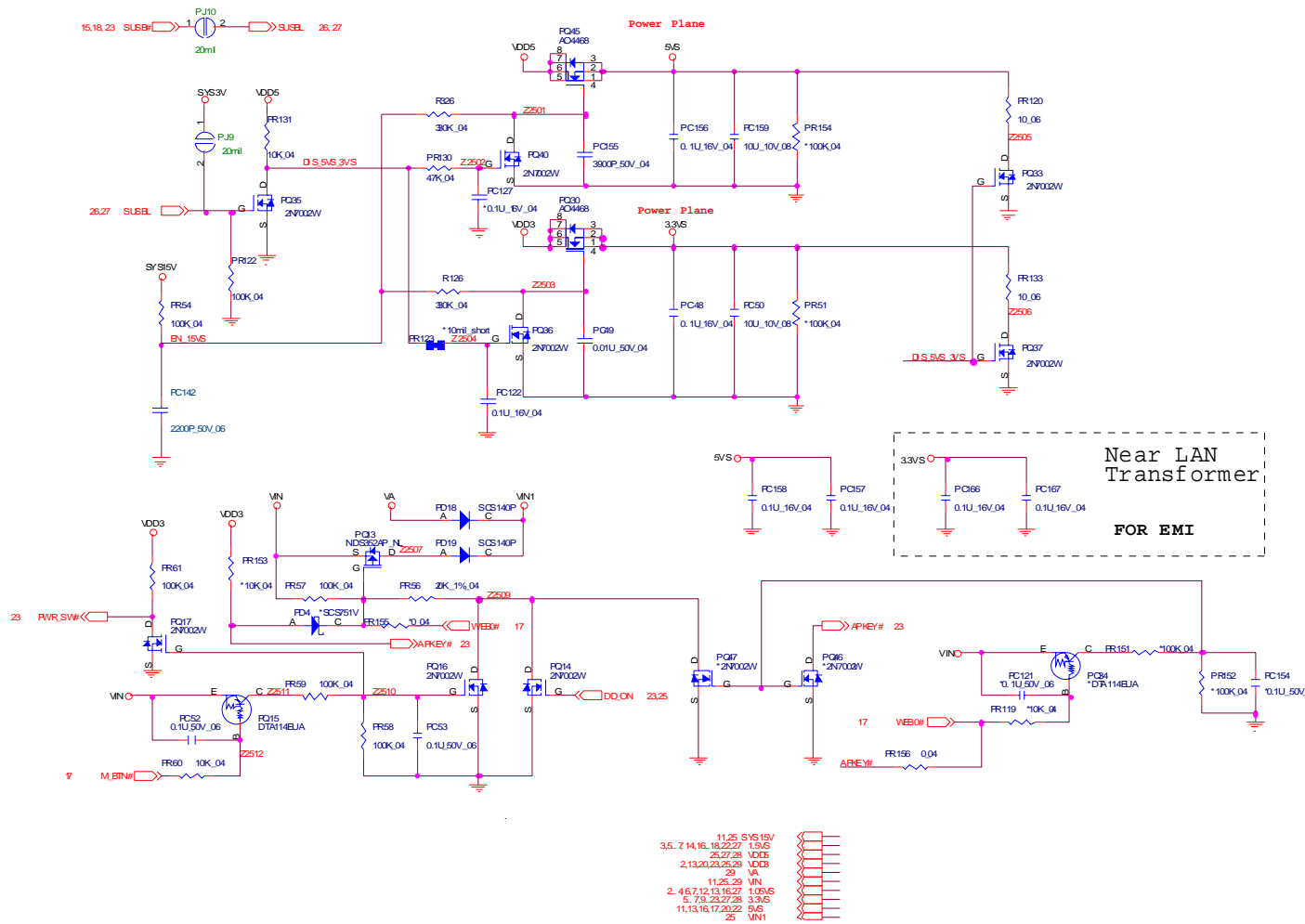

Sheet 24 of 32
3VS, 5VS

B. Schematic Diagrams

VDD3, VDD5

Sheet 25 of 32
VDD3, VDD5

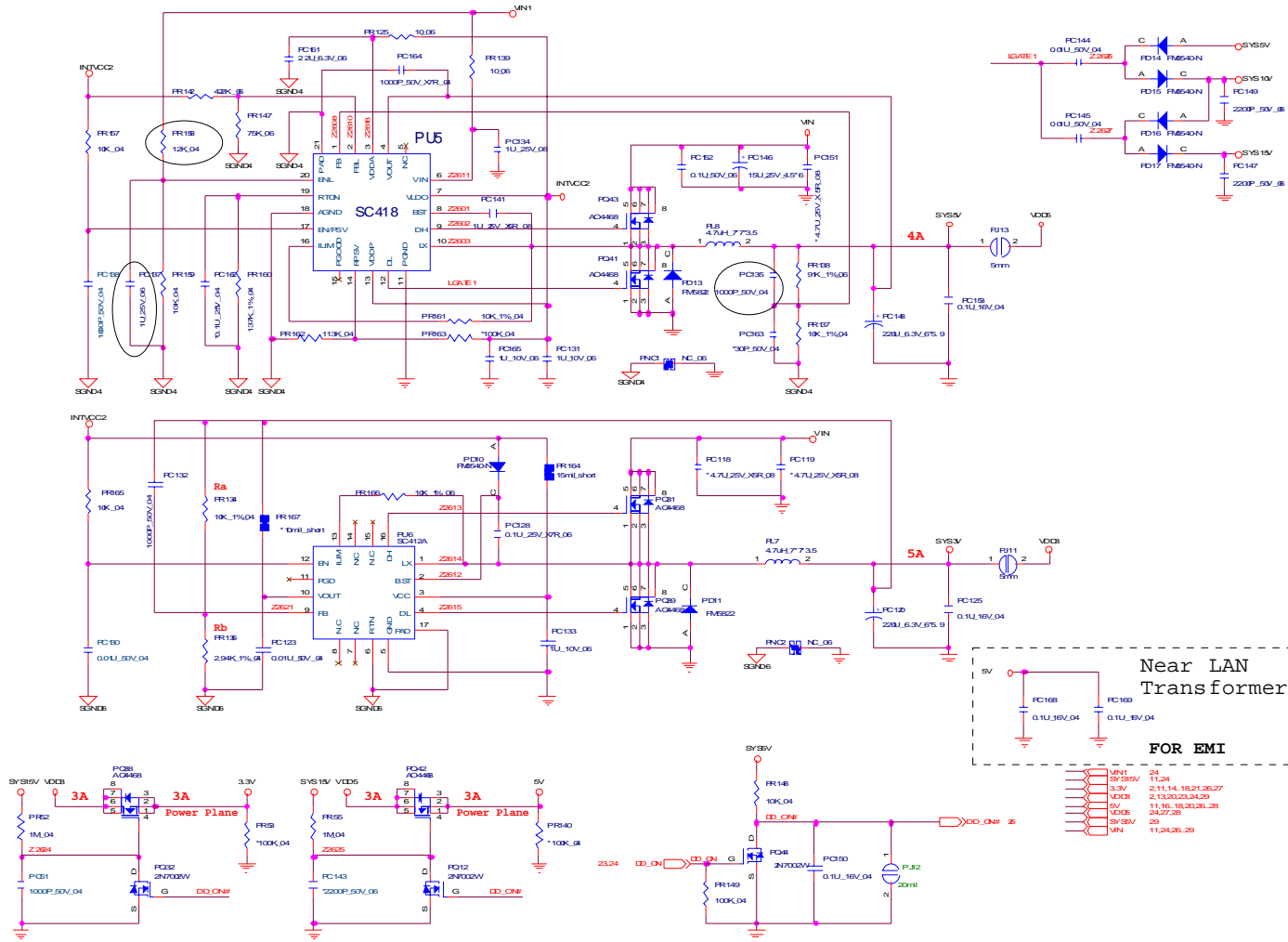

POWER 1.5VS/ 1.05VS

Sheet 27 of 32
POWER 1.5VS/
1.05VS

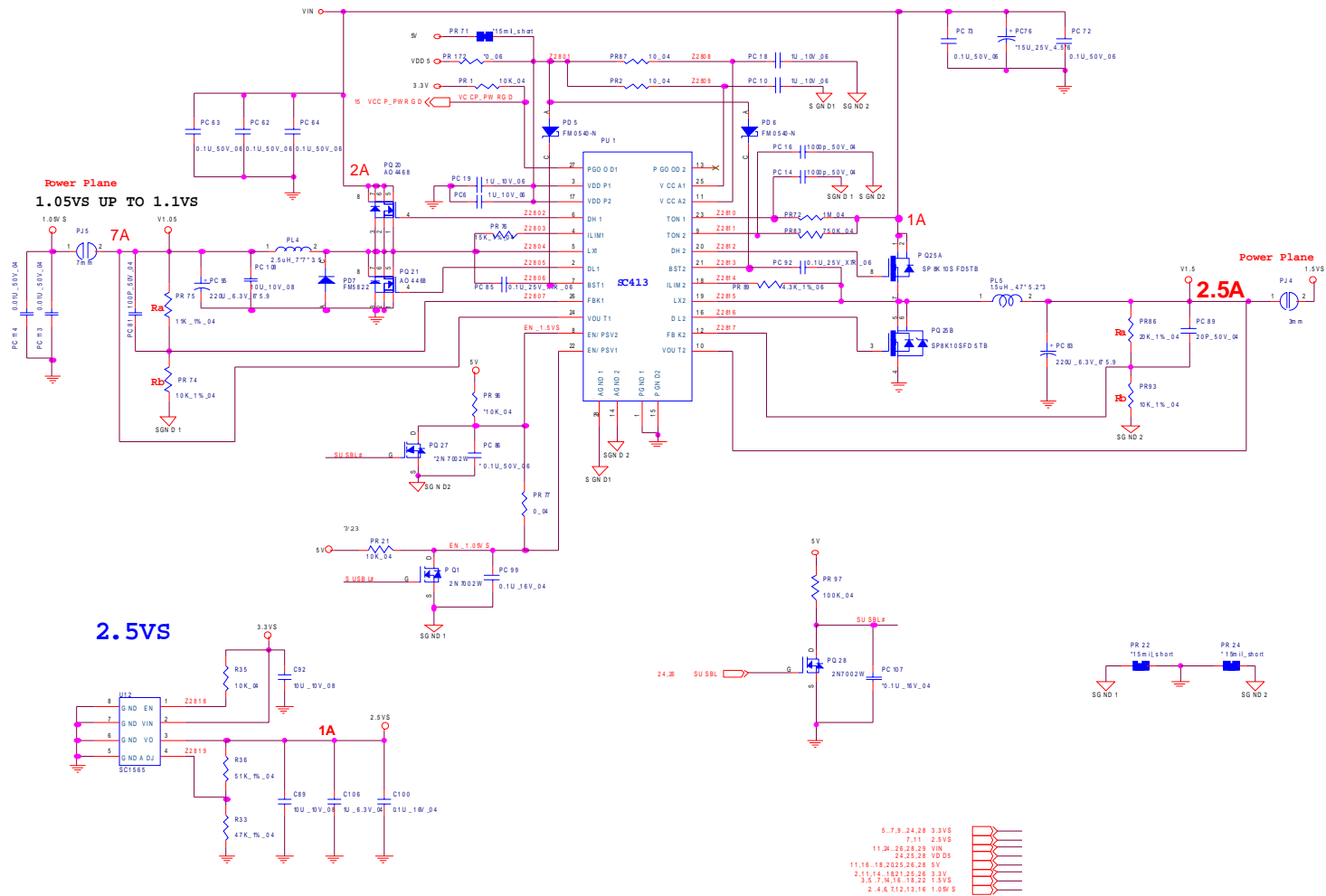

VCORE

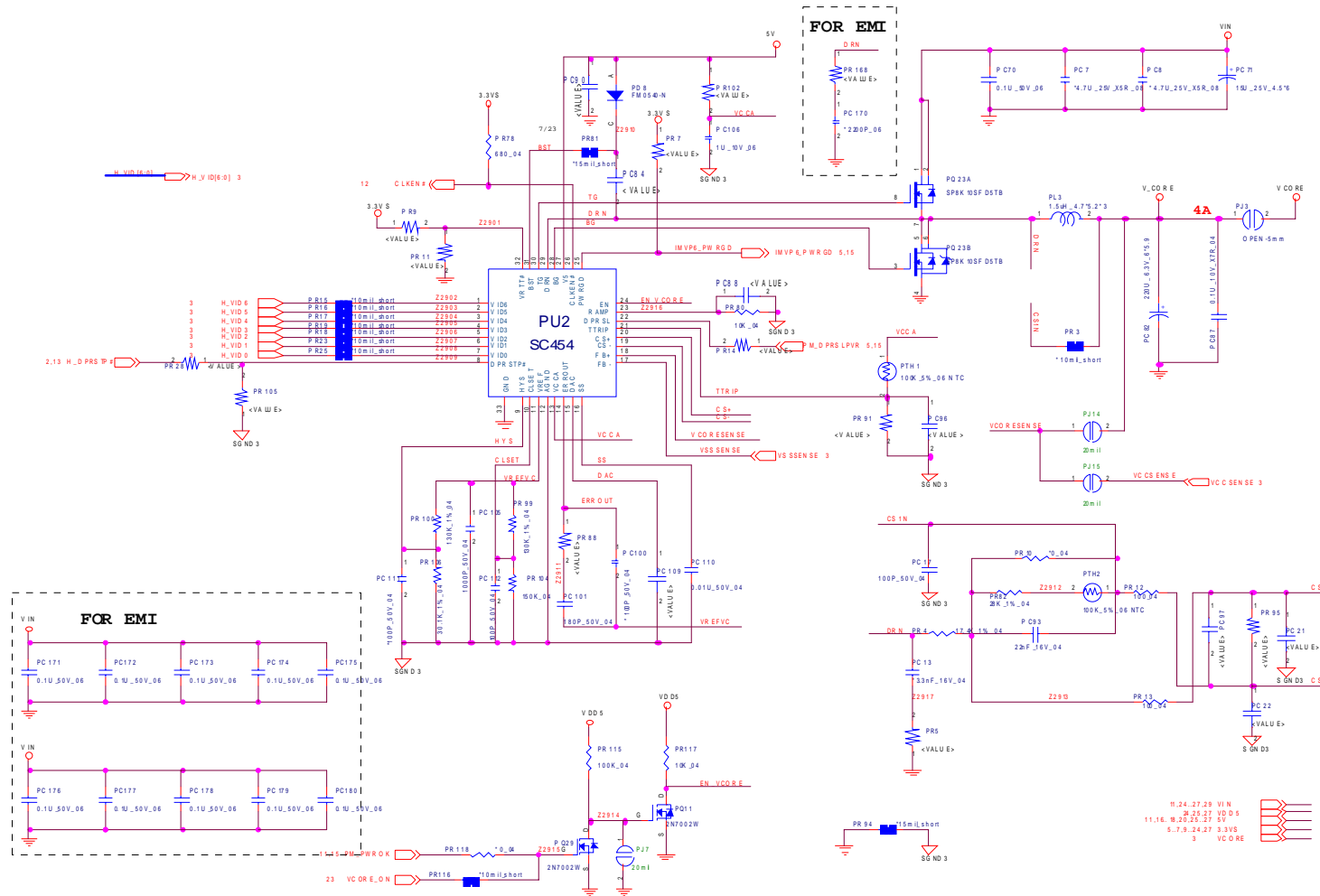

Sheet 28 of 32
VCORE

B.Schematic Diagrams

CLICK BOARD

CLICK BOARD

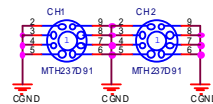
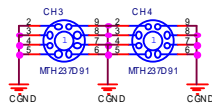
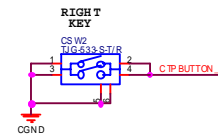
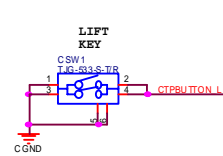
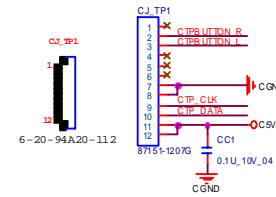
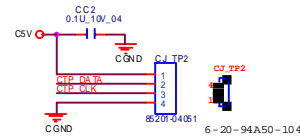

Sheet 30 of 32
CLICK BOARD

Multi B'd, LID, LED, SW, USB

Sheet 31 of 32
Multi B'd, LID, LED,
SW, USB

LID SWITCH IC

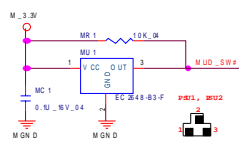

SPEAKER CONNECTOR

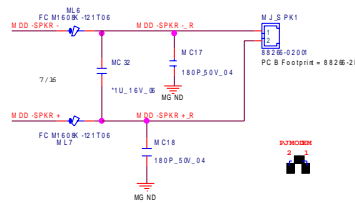

USB PORT

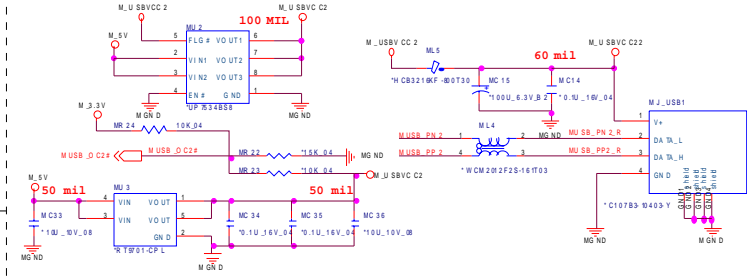

M_3.3VS NEED 4A

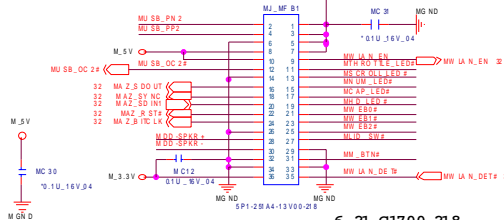

6-21-C1700-218

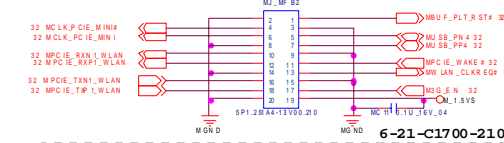

6-21-C1700-210

HOT KEY & POWER SW

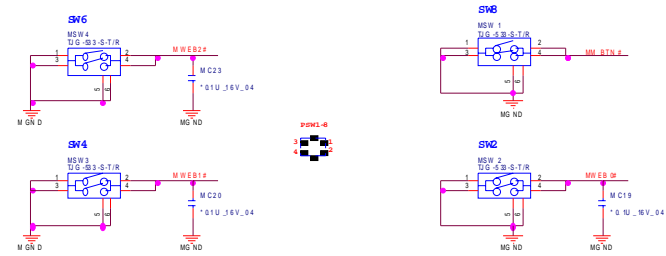

LED

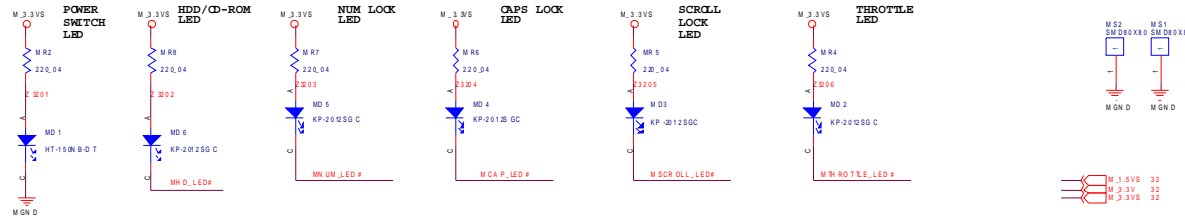

Schematic Diagrams

www.s-manuals.com