

SERVICE MANUAL

W130EV / W130EW

notebook



Notebook Computer

W130EV / W130EW

Service Manual

Notice

The company reserves the right to revise this publication or to change its contents without notice. Information contained herein is for reference only and does not constitute a commitment on the part of the manufacturer or any subsequent vendor. They assume no responsibility or liability for any errors or inaccuracies that may appear in this publication nor are they in anyway responsible for any loss or damage resulting from the use (or misuse) of this publication.

This publication and any accompanying software may not, in whole or in part, be reproduced, translated, transmitted or reduced to any machine readable form without prior consent from the vendor, manufacturer or creators of this publication, except for copies kept by the user for backup purposes.

Brand and product names mentioned in this publication may or may not be copyrights and/or registered trademarks of their respective companies. They are mentioned for identification purposes only and are not intended as an endorsement of that product or its manufacturer.

Version 1.0
June 2012

Trademarks

Intel, Pentium and Intel Core are trademarks of Intel Corporation.

Windows[®] is a registered trademark of Microsoft Corporation.

Other brand and product names are trademarks and /or registered trademarks of their respective companies.

About this Manual

This manual is intended for service personnel who have completed sufficient training to undertake the maintenance and inspection of personal computers.

It is organized to allow you to look up basic information for servicing and/or upgrading components of the *W130EV* / *W130EW* series notebook PC.

The following information is included:

Chapter 1, Introduction, provides general information about the location of system elements and their specifications.

Chapter 2, Disassembly, provides step-by-step instructions for disassembling parts and subsystems and how to upgrade elements of the system.

Appendix A, Part Lists

Appendix B, Schematic Diagrams

Appendix C, Updating the FLASH ROM BIOS

IMPORTANT SAFETY INSTRUCTIONS

Follow basic safety precautions, including those listed below, to reduce the risk of fire, electric shock and injury to persons when using any electrical equipment:

1. Do not use this product near water, for example near a bath tub, wash bowl, kitchen sink or laundry tub, in a wet basement or near a swimming pool.
2. Avoid using a telephone (other than a cordless type) during an electrical storm. There may be a remote risk of electrical shock from lightning.
3. Do not use the telephone to report a gas leak in the vicinity of the leak.
4. Use only the power cord and batteries indicated in this manual. Do not dispose of batteries in a fire. They may explode. Check with local codes for possible special disposal instructions.
5. This product is intended to be supplied by a Listed Power Unit with an AC Input of 100 - 240V, 50 - 60Hz, DC Output of 19V, 3.42A or 18.5V, 3.5A (65W) minimum AC/DC Adapter.

FCC Statement

This device complies with Part 15 of the FCC Rules. Operation is subject to the following two conditions:

This device may not cause harmful interference.

This device must accept any interference received, including interference that may cause undesired operation.

Instructions for Care and Operation

The notebook computer is quite rugged, but it can be damaged. To prevent this, follow these suggestions:

1. **Don't drop it, or expose it to shock.** If the computer falls, the case and the components could be damaged.



2. **Keep it dry, and don't overheat it.** Keep the computer and power supply away from any kind of heating element. This is an electrical appliance. If water or any other liquid gets into it, the computer could be badly damaged.

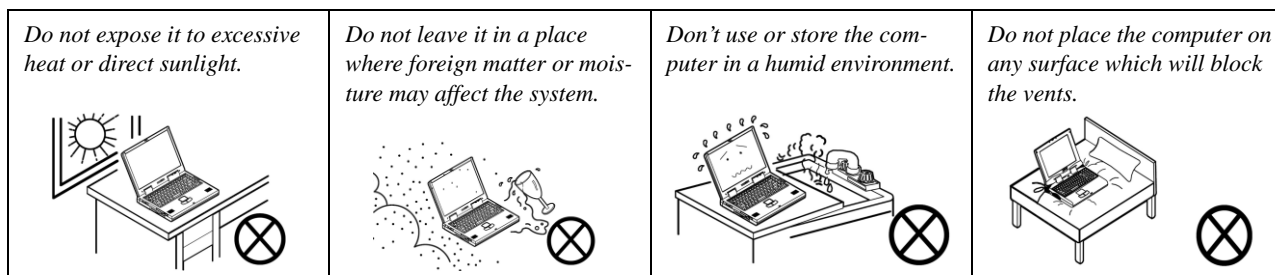

3. **Follow the proper working procedures for the computer.** Shut the computer down properly and don't forget to save your work. Remember to periodically save your data as data may be lost if the battery is depleted.

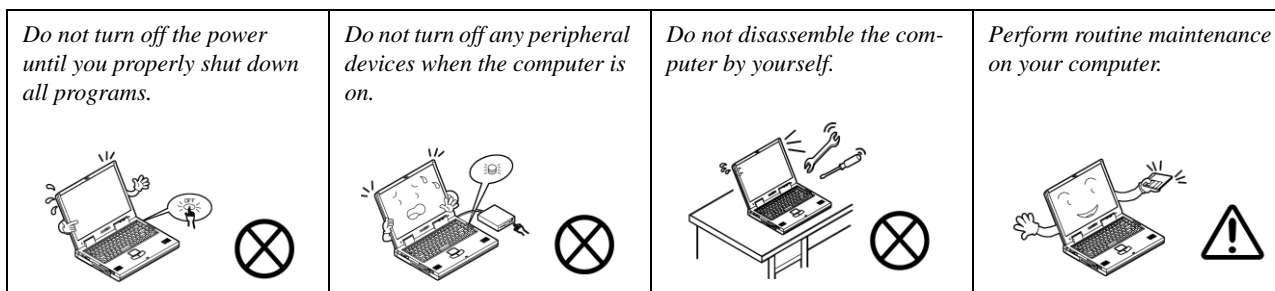

4. **Avoid interference.** Keep the computer away from high capacity transformers, electric motors, and other strong magnetic fields. These can hinder proper performance and damage your data.
5. **Take care when using peripheral devices.**

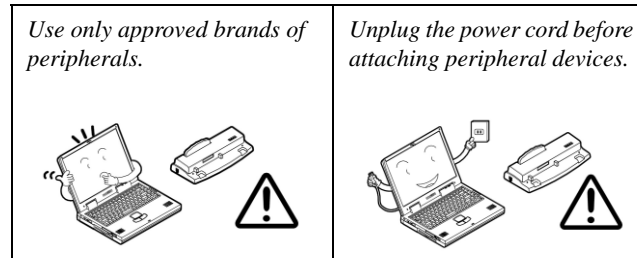

Power Safety

The computer has specific power requirements:

- Only use a power adapter approved for use with this computer.
- Your AC adapter may be designed for international travel but it still requires a steady, uninterrupted power supply. If you are unsure of your local power specifications, consult your service representative or local power company.
- The power adapter may have either a 2-prong or a 3-prong grounded plug. The third prong is an important safety feature; do not defeat its purpose. If you do not have access to a compatible outlet, have a qualified electrician install one.
- When you want to unplug the power cord, be sure to disconnect it by the plug head, not by its wire.
- Make sure the socket and any extension cord(s) you use can support the total current load of all the connected devices.
- Before cleaning the computer, make sure it is disconnected from any external power supplies.

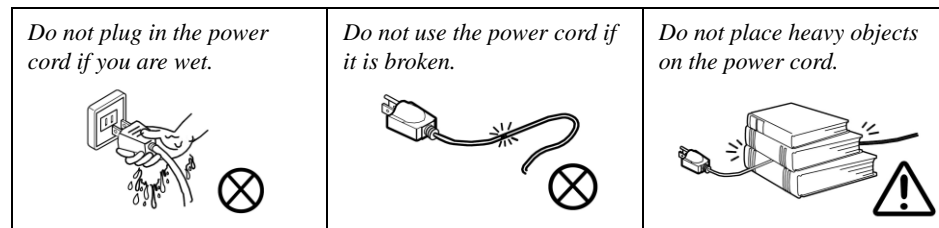

Power Safety Warning

Before you undertake any upgrade procedures, make sure that you have turned off the power, and disconnected all peripherals and cables (including telephone lines). It is advisable to also remove your battery in order to prevent accidentally turning the machine on.

Battery Precautions

- Only use batteries designed for this computer. The wrong battery type may explode, leak or damage the computer.
- Do not continue to use a battery that has been dropped, or that appears damaged (e.g. bent or twisted) in any way. Even if the computer continues to work with a damaged battery in place, it may cause circuit damage, which may possibly result in fire.
- Recharge the batteries using the notebook's system. Incorrect recharging may make the battery explode.
- Do not try to repair a battery pack. Refer any battery pack repair or replacement to your service representative or qualified service personnel.
- Keep children away from, and promptly dispose of a damaged battery. Always dispose of batteries carefully. Batteries may explode or leak if exposed to fire, or improperly handled or discarded.
- Keep the battery away from metal appliances.
- Affix tape to the battery contacts before disposing of the battery.
- Do not touch the battery contacts with your hands or metal objects.

Battery Guidelines

The following can also apply to any backup batteries you may have.

- If you do not use the battery for an extended period, then remove the battery from the computer for storage.
- Before removing the battery for storage charge it to 60% - 70%.
- Check stored batteries at least every 3 months and charge them to 60% - 70%.



Battery Disposal

The product that you have purchased contains a rechargeable battery. The battery is recyclable. At the end of its useful life, under various state and local laws, it may be illegal to dispose of this battery into the municipal waste stream. Check with your local solid waste officials for details in your area for recycling options or proper disposal.

Caution

Danger of explosion if battery is incorrectly replaced. Replace only with the same or equivalent type recommended by the manufacturer. Discard used battery according to the manufacturer's instructions.

Battery Level

Click the battery icon  in the taskbar to see the current battery level and charge status. A battery that drops below a level of 10% will not allow the computer to boot up. Make sure that any battery that drops below 10% is recharged within one week.

Related Documents

You may also need to consult the following manual for additional information:

User's Manual on CD/DVD

This describes the notebook PC's features and the procedures for operating the computer and its ROM-based setup program. It also describes the installation and operation of the utility programs provided with the notebook PC.

System Startup

1. Remove all packing materials.
2. Place the computer on a stable surface.
3. Insert the battery and make sure it is locked in position.
4. Securely attach any peripherals you want to use with the computer (e.g. keyboard and mouse) to their ports.
5. Attach the AC/DC adapter to the DC-In jack at the left of the computer, then plug the AC power cord into an outlet, and connect the AC power cord to the AC/DC adapter.
6. Use one hand to raise the lid/LCD to a comfortable viewing angle (do not exceed 120 degrees); use the other hand (as illustrated in Figure 1) to support the base of the computer (**Note: Never** lift the computer by the lid/LCD).
7. Press the power button to turn the computer "on".

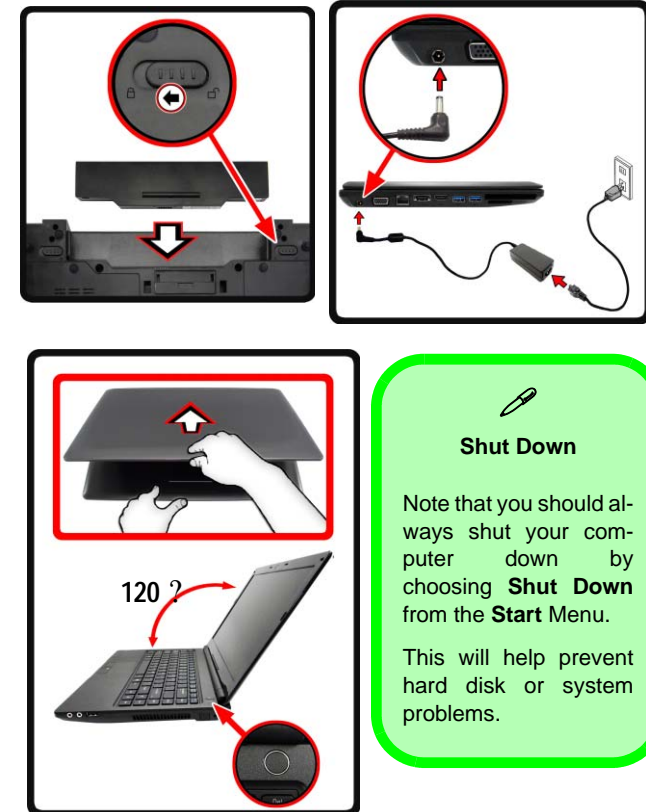

Figure 1
Opening the Lid/LCD/
Computer with AC/DC
Adapter Plugged-In

What to do if you Spill Liquid on the Computer

The keyboard incorporates a drainage system that minimizes the chances of liquid spillages on the keyboard penetrating the inside components of the computer. Liquid spilled on the computer is drained towards the right side of the computer. There is no guarantee that all water can be prevented from entering the computer, and damage resulting from spillages is not covered in the warranty. However if you follow the steps outlined here you should be able to prevent water from entering the sensitive parts of the computer and causing damage.

1. If you spill liquid on the computer immediately save any data required and then shut the computer down and disconnect the AC/DC adapter.
2. Carefully **lift the computer up and tilt it to a 90 degree angle towards the right side** (i.e. that right side of the computer should be at the bottom to allow **the water to drain away from the right side** and not the left).
3. Move the computer to a dry place and wipe any liquid off the keyboard and bottom of the computer using a clean, soft, dry cloth.
4. Remove the battery.
5. Leave the computer resting on its right side (while placed on a clean, soft, dry cloth) to dry out for about three hours.
6. Contact your service center to have the computer examined for any problems, **but do not attempt to turn the computer back on again** until after it has been examined.



Figure 2 - Drain any Liquid to the Right Side and Rest the Computer on the Right Side to Dry



Warranty Warning

Note that the keyboard drainage system is designed to help prevent and minimize damage from liquid spillages on the computer keyboard. However damage resulting from spillages is not covered in the warranty.

Contents

Introduction	1-1	LCD	A-6
Overview	1-1	Schematic Diagrams.....	B-1
Specifications	1-2	System Block Diagram	B-2
External Locator - Top View with LCD Panel Open	1-4	Processor 1/7	B-3
External Locator - Front & Right Side Views	1-5	Processor 2/7	B-4
External Locator - Left Side & Rear View	1-6	Processor 3/7	B-5
External Locator - Bottom View	1-7	Processor 4/7	B-6
Mainboard Overview - Top (Key Parts)	1-8	Processor 5/7	B-7
Mainboard Overview - Bottom (Key Parts)	1-9	Processor 6/7	B-8
Mainboard Overview - Top (Connectors)	1-10	Processor 7/7	B-9
Mainboard Overview - Bottom (Connectors)	1-11	DDR3 SO-DIMM_0	B-10
Disassembly	2-1	DDR3 SO-DIMM_1	B-11
Overview	2-1	LVDS, INVERTER	B-12
Maintenance Tools	2-2	HDMI	B-13
Connections	2-2	CRT	B-14
Maintenance Precautions	2-3	PCH 1/9	B-15
Disassembly Steps	2-4	PCH 2/9	B-16
Removing the Battery	2-5	PCH 3/9	B-17
Removing and Installing the Hard Disk Drive	2-6	PCH 4/9	B-18
Removing the System Memory (RAM)	2-9	PCH 5/9	B-19
Removing and Installing a Processor	2-10	PCH 6/9	B-20
Removing the 3.75G Module	2-13	PCH 7/9	B-21
Removing the Wireless LAN Module	2-14	PCH 8/9	B-22
Removing the Keyboard	2-15	PCH 9/9	B-23
Part Lists	A-1	NEW CARD, MINI PCIE	B-24
Part List Illustration Location	A-2	CCD, 3G	B-25
Top	A-3	TPM, HDD, USB3.0 CONN + PWR	B-26
Bottom	A-4	KBC-ITE IT8518	B-27
HDD	A-5	LED, MDC	B-28
		AUDIO CODEC VIA VT1802P	B-29

Preface

POWER CON, FAN, TP, CLICK CON	B-30
DOCKING CONNECTOR, COM PORT	B-31
AUDIO CONN, ESATA+USB+CHR	B-32
CARD READER JMC389	B-33
LAN (INTEL LAN82579)	B-34
INTEL LAN 82579LM	B-35
5VS, 3VS, 1.5VS CPU	B-36
Power 1.5V/0.75V,1.8VS	B-37
VDD3, VDD5	B-38
POWER 1.05V LAN_M	B-39
POWER 0.85VS	B-40
Power V-CORE 1	B-41
Power V-CORE 2	B-42
CHARGE, DC IN	B-43
CLICK BOARD / FG	B-44
AUDIO BOARD/ USB, HP, MIC	B-45
POWER SWITCH	B-46
DEBUG BOARD	B-47
Power Sequence	B-48
Updating the FLASH ROM BIOS.....	C-1
Download the BIOS	C-1
Unzip the downloaded files to a bootable CD/DVD/ or USB Flash drive	C-1
Set the computer to boot from the external drive	C-1
Use the flash tools to update the BIOS	C-2
Restart the computer (booting from the HDD)	C-2

Chapter 1: Introduction

Overview

This manual covers the information you need to service or upgrade the **W130EV / W130EW** series notebook computer. Information about operating the computer (e.g. getting started, and the *Setup* utility) is in the *User's Manual*. Information about drivers (e.g. VGA & audio) is also found in the *User's Manual*. The manual is shipped with the computer.

Operating systems (e.g. *Window 7*, etc.) have their own manuals as do application softwares (e.g. word processing and database programs). If you have questions about those programs, you should consult those manuals.

The **W130EV / W130EW** series notebook is designed to be upgradeable. See [Disassembly on page 2 - 1](#) for a detailed description of the upgrade procedures for each specific component. Please take note of the warning and safety information indicated by the “” symbol.

The balance of this chapter reviews the computer's technical specifications and features.

Specifications



Latest Specification Information

The specifications listed here are correct at the time of sending them to the press. Certain items (particularly processor types/speeds) may be changed, delayed or updated due to the manufacturer's release schedule. Check with your service center for more details.



CPU

The CPU is not a user serviceable part. Accessing the CPU in any way may violate your warranty.

Processor Options

W130EW:

Intel® Core™ i7 Processor

i7-3612QM (2.10GHz)

6MB L3 Cache, **22nm**, DDR3-1600MHz, TDP 35W

i7-3520M (2.90GHz)

4MB L3 Cache, **22nm**, DDR3-1600MHz, TDP 35W

Intel® Core™ i5 Processor

i5-3360M (2.80GHz), i5-3320M (2.60GHz), i5-3210M (2.50GHz)

3MB L3 Cache, **22nm**, DDR3-1600MHz, TDP 35W

Intel® Core™ i3 Processor

i3-3110M (2.40GHz)

3MB L3 Cache, **22nm**, DDR3-1600MHz, TDP 35W

Intel® Core™ i7 Processor

i7-2640M (2.80GHz)

4MB L3 Cache, **32nm**, DDR3-1333MHz, TDP 35W

Intel® Core™ i5 Processor

i5-2540M (2.60GHz), i5-2520M (2.50GHz), i5-2450M (2.50GHz), i5-2430M (2.40GHz)

3MB L3 Cache, **32nm**, DDR3-1333MHz, TDP 35W

Intel® Core™ i3 Processor

i3-2370M (2.40GHz), i3-2350M (2.30GHz),

3MB L3 Cache, **32nm**, DDR3-1333MHz, TDP 35W

Intel® Pentium™ Processor

B980 (2.40GHz), B970 (2.30GHz), B960 (2.20GHz), B950 (2.10GHz)

2MB L3 Cache, **32nm**, DDR3-1333MHz, TDP 35W

W130EV:

Intel® Core™ i7 Processor

i7-3520M (2.90GHz)

4MB L3 Cache, **22nm**, DDR3-1600MHz, TDP 35W

Intel® Core™ i5 Processor

i5-3360M (2.80GHz), i5-3320M (2.60GHz)

3MB L3 Cache, **22nm**, DDR3-1600MHz, TDP 35W

LCD

13.3" (33.78cm) HD LCD

BIOS

AMI BIOS (One 64Mb SPI Flash ROM)

Core Logic

W130EW:

Intel® HM77 Chipset

W130EV:

Intel® QM77 Chipset

Memory

Two 204 Pin SO-DIMM Sockets Supporting **DDR3 1333/1600MHz** Memory

Memory Expandable up to **8GB**

(The real memory operating frequency depends on the FSB of the processor.)

Video Adapter (W130EW)

Intel Integrated GPU

(GPU is Dependent on Processor)

Intel® HD Graphics

Dynamic Frequency (Intel Dynamic Video Memory Technology for up to **1.7GB**)

Microsoft DirectX®10 Compatible

Intel® HD Graphics 3000

Dynamic Frequency (Intel Dynamic Video Memory Technology for up to **1.7GB**)

Microsoft DirectX®10 Compatible

Intel® HD Graphics 4000

Dynamic Frequency (Intel Dynamic Video Memory Technology for up to **1.7GB**)

Microsoft DirectX®11 Compatible

Video Adapter (W130EV)

Intel® HD Graphics 4000

Dynamic Frequency (Intel Dynamic Video Memory Technology for up to **1.7GB**)

Microsoft DirectX®11 Compatible

Storage

One Changeable 2.5" 9.5 mm (h) SATA (Serial) HDD
Anti-Shock System

Audio

High Definition Audio Compliant Interface
2 * Built-In Speakers
Built-In Microphone

Security

BIOS Password
Security (Kensington® Type) Lock Slot
Fingerprint Reader
TPM v1.2
Intel vPro (**W130EV only**)

Keyboard

Isolated A4 Size Keyboard with Anti-Spray Support

Pointing Device

Built-in Touchpad (scrolling key functionality integrated)

Interface

One Powered USB 2.0 Port
Two USB 3.0 Ports
One eSATA/USB 2.0 Combo Port
One HDMI-Out Port
One Headphone-Out Jack
One Microphone-In Jack
One RJ-45 LAN Jack
One External Monitor Port
One ExpressCard/34(54) Slot
One DC-in Jack
(**Factory Option**) One Docking Port

Communication

Built-In Gigabit Ethernet LAN
(**Factory Option**) 1.3M Pixels/2M Pixels (HD) PC Camera Module
(**Factory Option**) 3G Module (UMTS/HSPA or UMTS/HSPA+)

WLAN/ Bluetooth Half Mini-Card Modules:**W130EW:**

(**Factory Option**) Intel® Centrino® Wireless-N 2230 Wireless LAN (**802.11b/g/n**) + Bluetooth **4.0**
(**Factory Option**) Intel® Centrino® Wireless-N 135 Wireless LAN (**802.11b/g/n**) + Bluetooth **4.0**
(**Factory Option**) Third-Party Wireless LAN (**802.11b/g/n**) + Bluetooth **4.0**
(**Factory Option**) Third-Party Wireless LAN (**802.11b/g/n**)

W130EV:

(**Factory Option**) Intel® Centrino® Advanced-N 6235 Wireless LAN (**802.11a/g/n**) + Bluetooth **4.0**
(**Factory Option**) Intel® Centrino® Advanced-N 6205 Wireless LAN (**802.11a/g/n**)

Card Reader

Embedded Multi-in-1 Push-Push Card Reader
MMC (MultiMedia Card) / RS MMC
SD (Secure Digital) / Mini SD / SDHC/ SDXC
MS (Memory Stick) / MS Pro / MS Duo

Mini Card Slots

Slot 1 for **WLAN** Module or **WLAN and Bluetooth** Combo Module
(**Factory Option**) Slot 2 for **3G** Module

Environmental Spec**Temperature**

Operating: 5°C - 35°C
Non-Operating: -20°C - 60°C

Relative Humidity

Operating: 20% - 80%
Non-Operating: 10% - 90%

Power

Full Range AC/DC Adapter
AC Input: 100 - 240V, 50 - 60Hz
DC Output: 19V, 3.42A or 18.5V, 3.5A (**65W**)

6 Cell Smart Lithium-Ion Battery Pack, 62.16WH

Dimensions & Weight

330mm (w) * 225mm (d) * 24.5 - 32mm (h)
1.78kg with 62.16WH Battery

Introduction

External Locator - Top View with LCD Panel Open

Figure 1
Top View

1. PC Camera
(Optional)
2. LCD
3. Power Button
4. Keyboard
5. Built-In
Microphone
6. Touchpad &
Buttons
7. Fingerprint Reader
8. LED Status
Indicators



External Locator - Front & Right Side Views

FRONT VIEW



Figure 2
Front View

1. LED Power Indicator
2. WLAN Switch

RIGHT SIDE VIEW



Figure 3
Right Side View

1. Microphone-In Jack
2. Headphone-Out Jack
3. USB 2.0 Port
4. Vent
5. Security Lock Slot

Introduction

External Locator - Left Side & Rear View

Figure 4
Left Side View

1. DC-In Jack
2. External Monitor Port
3. RJ-45 LAN Jack
4. e-SATA Port/USB 2.0 Combo Port
5. HDMI-Out Port
6. 2 * USB 3.0 Ports
7. ExpressCard/54(34) Slot
8. Multi-in-1 Card Reader



Figure 5
Rear View

1. Battery



External Locator - Bottom View

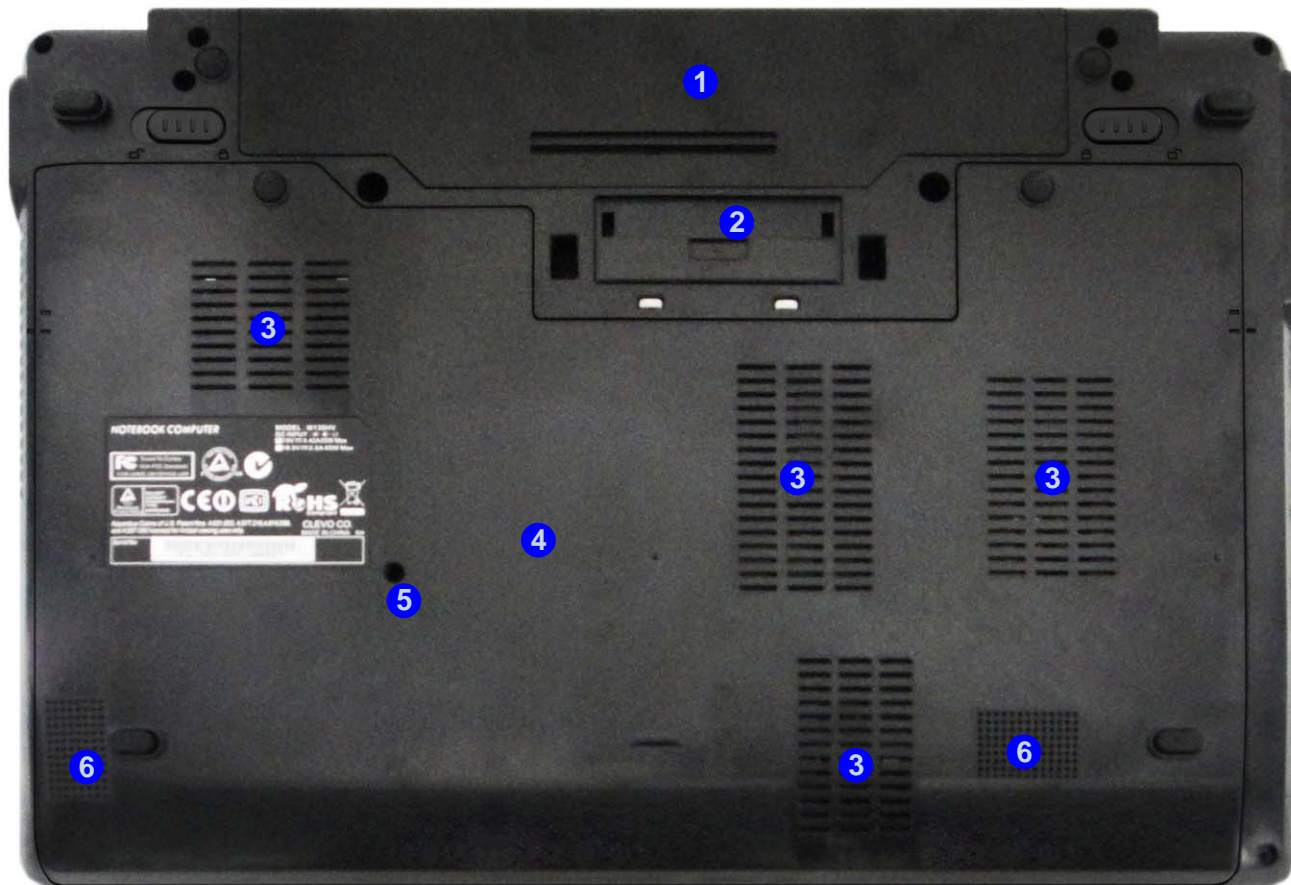

Figure 6
Bottom View

1. Battery
2. Docking Port
3. Vent
4. Component Bay Cover
5. Drainage Outlet
6. Speakers



Overheating

To prevent your computer from overheating, make sure nothing blocks any vent while the computer is in use.

Introduction

Figure 7
Mainboard Top
Key Parts

1. PI3L720ZHE
2. TUSB7320
3. ITE IT870SE
4. SIMLOCK

Mainboard Overview - Top (Key Parts)

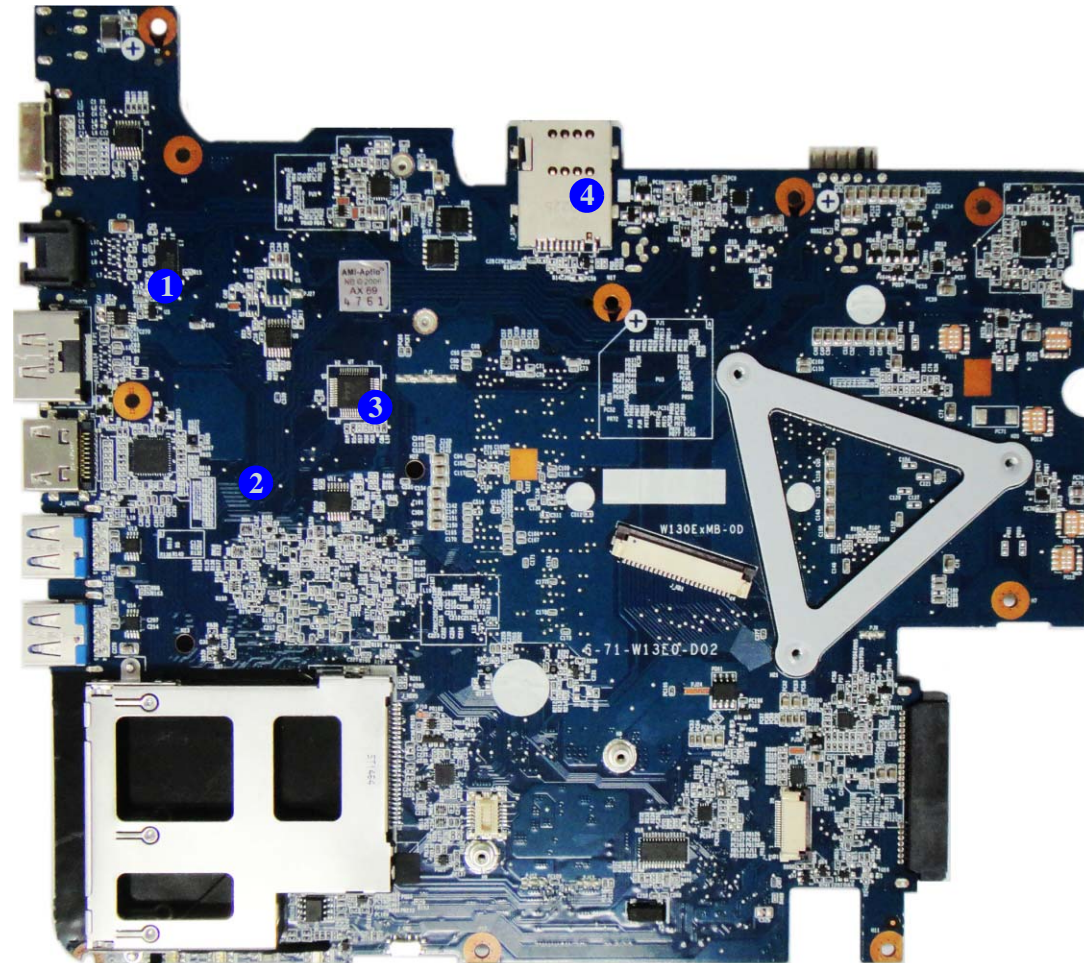

Mainboard Overview - Bottom (Key Parts)

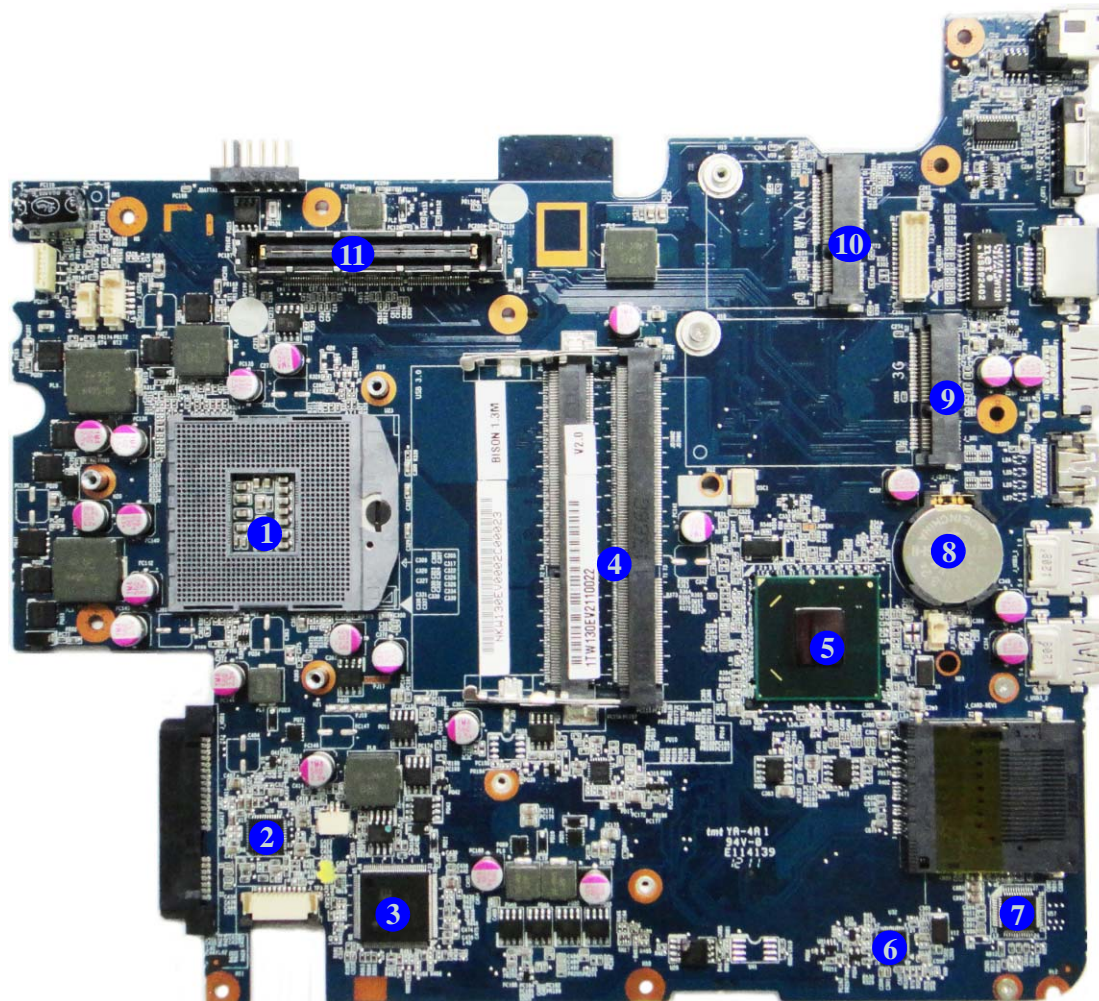

Figure 8
**Mainboard Bottom
Key Parts**

1. CPU Socket (no CPU installed)
2. Audio Codec VT1802P
3. ITE IT8518E
4. Memory Slots DDR3 SO-DIMM
5. Platform Controller Hub
6. LAN 82579
7. Card Reader JMB369
8. CMOS Battery
9. Mini-Card Connector (3G Module)
10. Mini-Card Connector (WLAN Module)
11. Docking Station Connector

Introduction

Figure 9
**Mainboard Top
Connectors**

1. e-SATA Port/USB 2.0 Combo Port
2. HDMI-Out Port
3. USB Port 3.0
4. Audio Board Connector
5. Keyboard Cable Connector

Mainboard Overview - Top (Connectors)

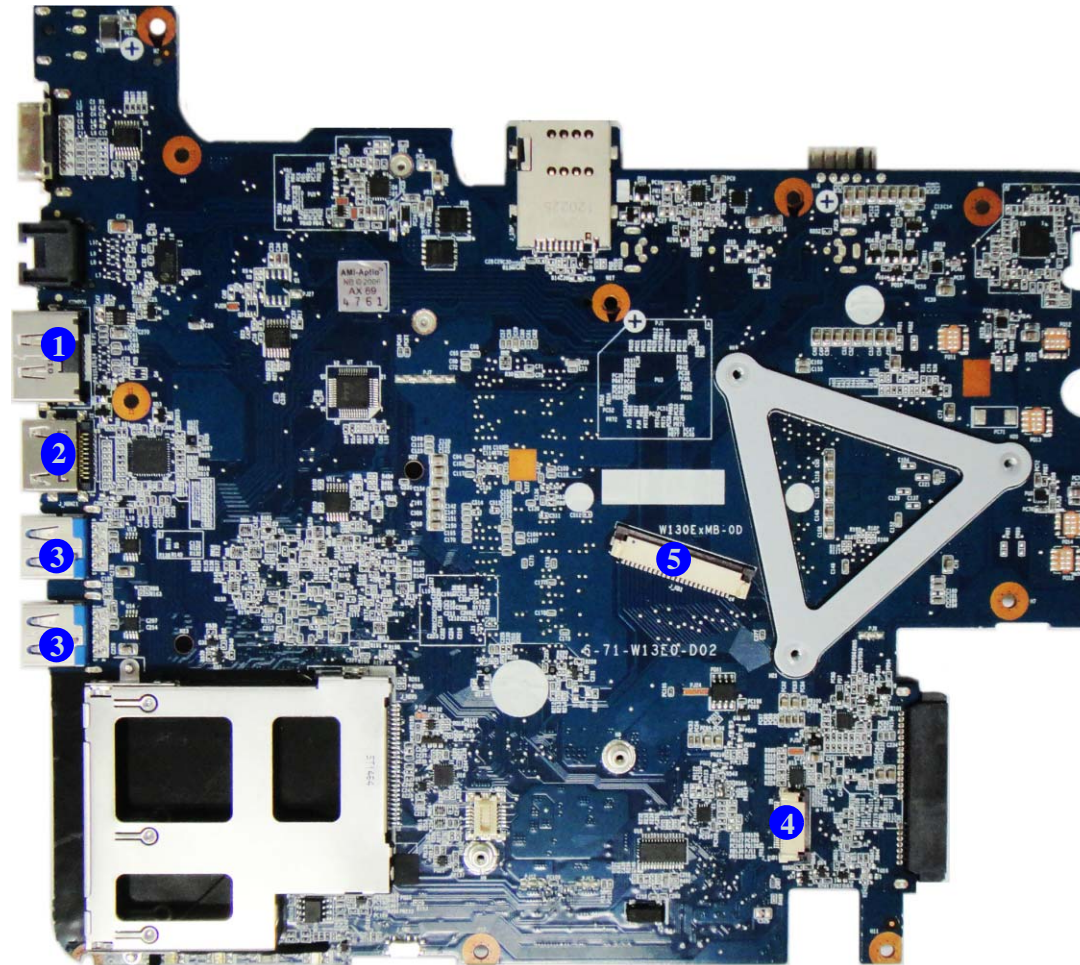

Mainboard Overview - Bottom (Connectors)

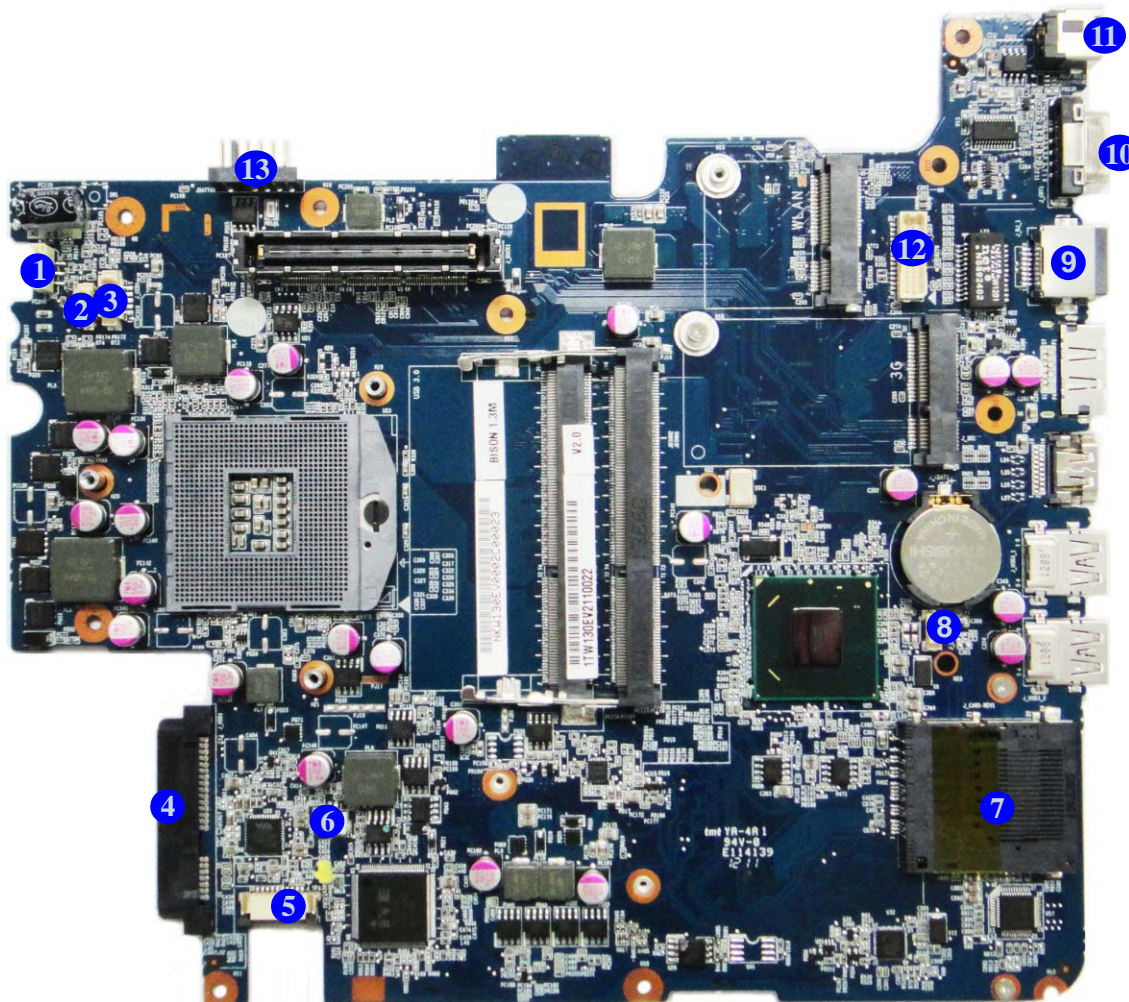

Figure 10
**Mainboard Bottom
Connectors**

1. Power Cable Connector
2. Fan Cable Connector
3. CCD Cable Connector
4. HDD Connector
5. TouchPad Cable Connector
6. Microphone Cable Connector
7. Multi-in-1 Card Reader
8. Speaker Cable Connector
9. RJ-45 LAN Jack
10. External Monitor Port
11. DC-In Jack
12. LVDS Cable Connector
13. Battery Connector

Chapter 2: Disassembly

Overview

This chapter provides step-by-step instructions for disassembling the *WI30EV / WI30EW* series notebook's parts and subsystems. When it comes to reassembly, reverse the procedures (unless otherwise indicated).

We suggest you completely review any procedure before you take the computer apart.

Procedures such as upgrading/replacing the RAM, optical device and hard disk are included in the User's Manual but are repeated here for your convenience.

To make the disassembly process easier each section may have a box in the page margin. Information contained under the figure # will give a synopsis of the sequence of procedures involved in the disassembly procedure. A box with a  lists the relevant parts you will have after the disassembly process is complete. **Note:** The parts listed will be for the disassembly procedure listed ONLY, and not any previous disassembly step(s) required. Refer to the part list for the previous disassembly procedure. The amount of screws you should be left with will be listed here also.

A box with a  will also provide any possible helpful information. A box with a  contains warnings.

An example of these types of boxes are shown in the sidebar.

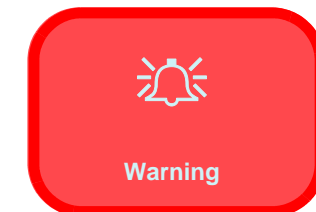

Disassembly

NOTE: All disassembly procedures assume that the system is turned **OFF**, and disconnected from any power supply (the battery is removed too).

Maintenance Tools

The following tools are recommended when working on the notebook PC:

- M3 Philips-head screwdriver
- M2.5 Philips-head screwdriver (magnetized)
- M2 Philips-head screwdriver
- Small flat-head screwdriver
- Pair of needle-nose pliers
- Anti-static wrist-strap

Connections

Connections within the computer are one of four types:

Locking collar sockets for ribbon connectors	To release these connectors, use a small flat-head screwdriver to gently pry the locking collar away from its base. When replacing the connection, make sure the connector is oriented in the same way. The pin1 side is usually not indicated.
Pressure sockets for multi-wire connectors	To release this connector type, grasp it at its head and gently rock it from side to side as you pull it out. Do not pull on the wires themselves. When replacing the connection, do not try to force it. The socket only fits one way.
Pressure sockets for ribbon connectors	To release these connectors, use a small pair of needle-nose pliers to gently lift the connector away from its socket. When replacing the connection, make sure the connector is oriented in the same way. The pin1 side is usually not indicated.
Board-to-board or multi-pin sockets	To separate the boards, gently rock them from side to side as you pull them apart. If the connection is very tight, use a small flat-head screwdriver - use just enough force to start.

Maintenance Precautions

The following precautions are a reminder. To avoid personal injury or damage to the computer while performing a removal and/or replacement job, take the following precautions:

1. **Don't drop it.** Perform your repairs and/or upgrades on a stable surface. If the computer falls, the case and other components could be damaged.
2. **Don't overheat it.** Note the proximity of any heating elements. Keep the computer out of direct sunlight.
3. **Avoid interference.** Note the proximity of any high capacity transformers, electric motors, and other strong magnetic fields. These can hinder proper performance and damage components and/or data. You should also monitor the position of magnetized tools (i.e. screwdrivers).
4. **Keep it dry.** This is an electrical appliance. If water or any other liquid gets into it, the computer could be badly damaged.
5. **Be careful with power.** Avoid accidental shocks, discharges or explosions.
 - Before removing or servicing any part from the computer, turn the computer off and detach any power supplies.
 - When you want to unplug the power cord or any cable/wire, be sure to disconnect it by the plug head. Do not pull on the wire.
6. **Peripherals** – Turn off and detach any peripherals.
7. **Beware of static discharge.** ICs, such as the CPU and main support chips, are vulnerable to static electricity. Before handling any part in the computer, discharge any static electricity inside the computer. When handling a printed circuit board, do not use gloves or other materials which allow static electricity buildup. We suggest that you use an anti-static wrist strap instead.
8. **Beware of corrosion.** As you perform your job, avoid touching any connector leads. Even the cleanest hands produce oils which can attract corrosive elements.
9. **Keep your work environment clean.** Tobacco smoke, dust or other air-borne particulate matter is often attracted to charged surfaces, reducing performance.
10. **Keep track of the components.** When removing or replacing any part, be careful not to leave small parts, such as screws, loose inside the computer.

Cleaning

Do not apply cleaner directly to the computer, use a soft clean cloth.

Do not use volatile (petroleum distillates) or abrasive cleaners on any part of the computer.



Power Safety Warning

Before you undertake any upgrade procedures, make sure that you have turned off the power, and disconnected all peripherals and cables (including telephone lines). It is advisable to also remove your battery in order to prevent accidentally turning the machine on.

Disassembly Steps

The following table lists the disassembly steps, and on which page to find the related information. **PLEASE PERFORM THE DISASSEMBLY STEPS IN THE ORDER INDICATED.**

To remove the Battery:

1. Remove the battery *page 2 - 5*

To remove the HDD:

1. Remove the battery *page 2 - 5*
2. Remove the HDD *page 2 - 6*

To remove the System Memory:

1. Remove the battery *page 2 - 5*
2. Remove the system memory *page 2 - 9*

To remove and install a Processor:

1. Remove the battery *page 2 - 5*
2. Remove the processor *page 2 - 10*
3. Install the processor *page 2 - 12*

To remove the 3.75G Module:

1. Remove the battery *page 2 - 5*
2. Remove the 3.75G module *page 2 - 13*

To remove the Wireless LAN Module:

1. Remove the battery *page 2 - 5*
2. Remove the WLAN module *page 2 - 14*

To remove the Keyboard:

1. Remove the battery *page 2 - 5*
2. Remove the keyboard *page 2 - 15*

Removing the Battery

1. Turn the computer **off**, and turn it over.
2. Slide the latch **1** in the direction of the arrow (*Figure 1a*).
3. Slide the latch **2** in the direction of the arrow, and hold it in place (*Figure 1a*).
4. Slide the battery **3** in the direction of the arrow **4** (*Figure 1b*).

Figure 1
Battery Removal

- a. Slide the latch and hold it in place.
- b. Slide the battery in the direction of the arrow.

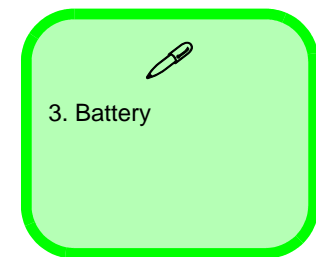
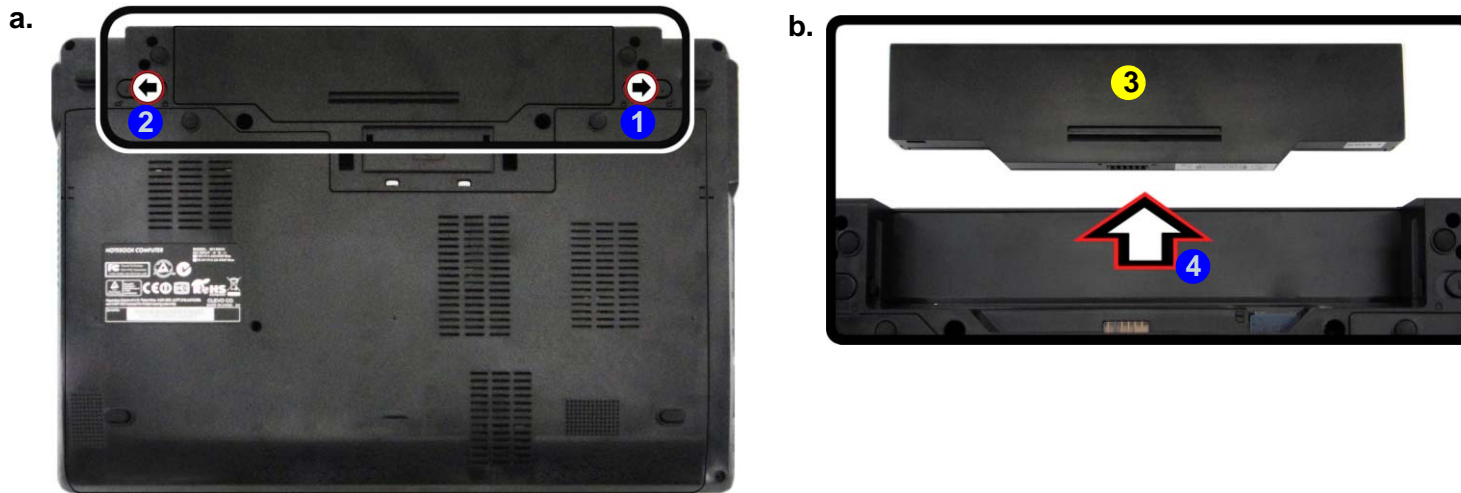

Disassembly

Figure 2
**HDD Assembly
Removal**

- Slide the latches and latch ② hold it in place.
- Remove the component bay cover.

Removing and Installing the Hard Disk Drive

Hdd Removal Procedure

The hard disk drive can be taken out to accommodate other 2.5" serial (SATA) hard disk drives with a height of 9.5mm (h). Follow your operating system's installation instructions, and install all necessary drivers and utilities (as outlined in **Chapter 4 of the User's Manual**) when setting up a new hard disk.

Hard Disk Upgrade Process

- Turn **off** the computer, and remove the battery ([page 2 - 5](#)).
- Slide the latch ① in the direction of the arrow and slide the latch ② in the direction of the arrow, and hold it in place and carefully slide the cover in the direction of the arrow ③ to align with the markers on the case ④.
- Lift the component bay cover ⑤ off the computer.
- When reinserting the cover align the markers on the case ④ and cover first, and then slide the cover until it clicks into place.

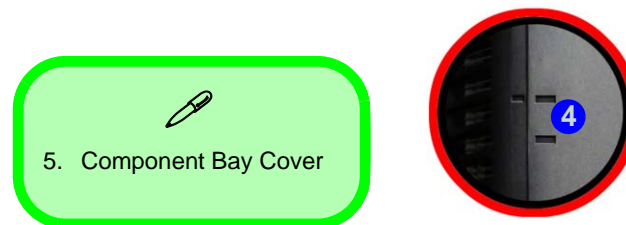
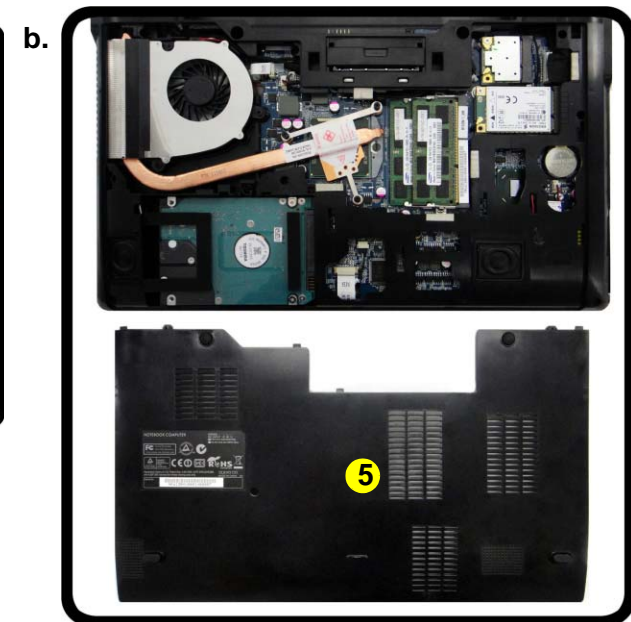
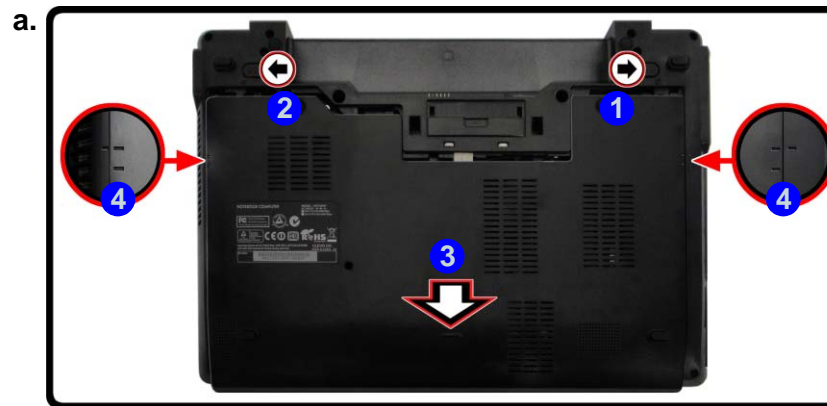

HDD System Warning

New HDD's are blank. Before you begin make sure:

You have backed up any data you want to keep from your old HDD.

You have all the CD-ROMs and FDDs required to install your operating system and programs.

If you have access to the internet, download the latest application and hardware driver updates for the operating system you plan to install. Copy these to a removable medium.

5. Raise the plastic tab ⑥.
6. Slide the hard disk assembly in the direction of arrow ⑦ until you can see the (gold colored) HDD connector ⑧.
7. When the connector can be viewed, lift the assembly up in the direction of arrow ⑨ remove the HDD assembly from the bay.
8. Remove the screws ⑩ & ⑪ and the mylar cover ⑫ from the hard disk ⑬ (Figure 3e)..

Figure 3
HDD Assembly
Removal (cont'd.)

- c. Raise the plastic tab.
- d. Grip the tab and slide the HDD assembly in the direction of the arrow.
- e. Lift the HDD assembly out of the bay.
- f. Remove the screws and mylar cover.

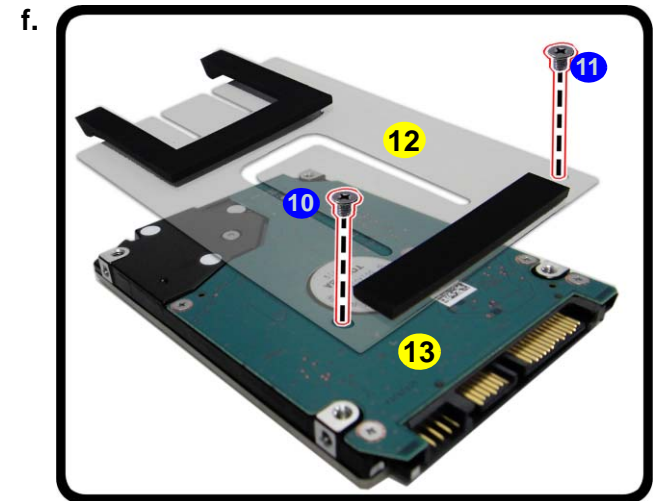
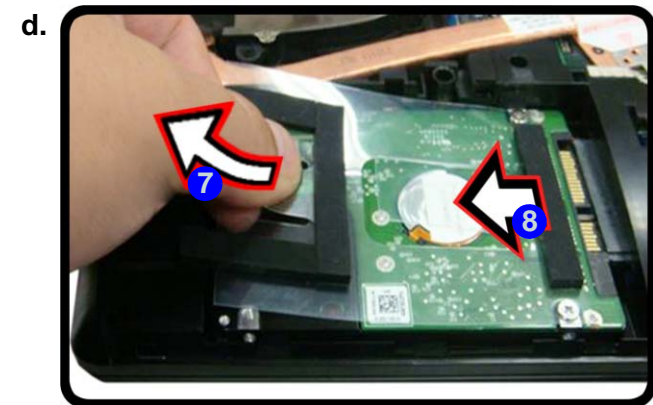
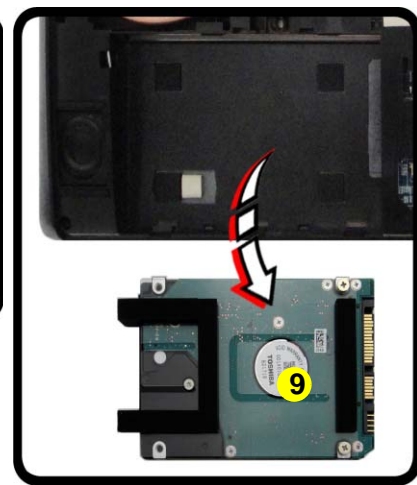
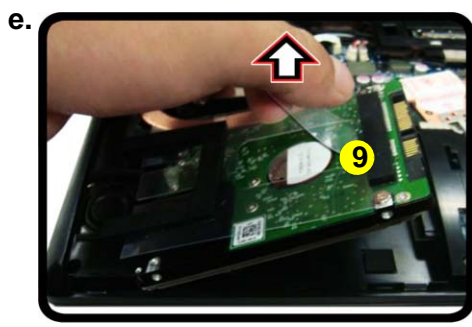
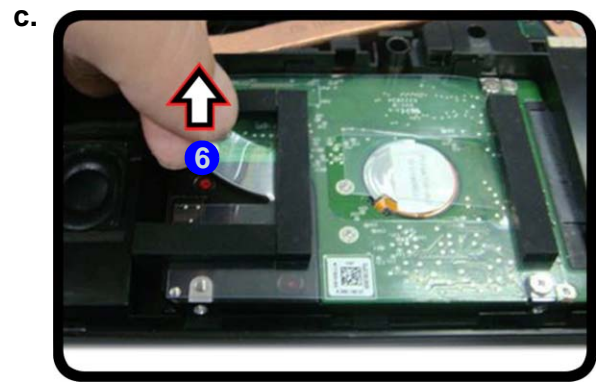

- 9. HDD Assembly
- 12. Mylar Cover
- 13. HDD
- 2 Screws

Disassembly

Figure 4
HDD Installation

- Insert the HDD directly down into the bay vertically.
- Press and slide the HDD assembly at the area illustrated **2**
- Press down on the rubber case



Hard Disk Handling

Do not press down on the center off the hard disk as this area houses the hard disk drive motor.



1. HDD Assembly

Reinserting the HDD

- To reinsert the HDD assembly **1** hold it carefully at the four corners between your thumb and forefinger and Insert the HDD directly down into the bay vertically (*Figure 1a*).
- Press and slide the HDD assembly at the area illustrated **2** (do not press on the center area - see sidebar) the direction of arrows to make sure the HDD fits securely into the connector.
- Press down on the rubber case **3** to ensure the assembly is properly seated before replacing the cover and screws.
- Replace the component bay cover (*page 2 - 6*).

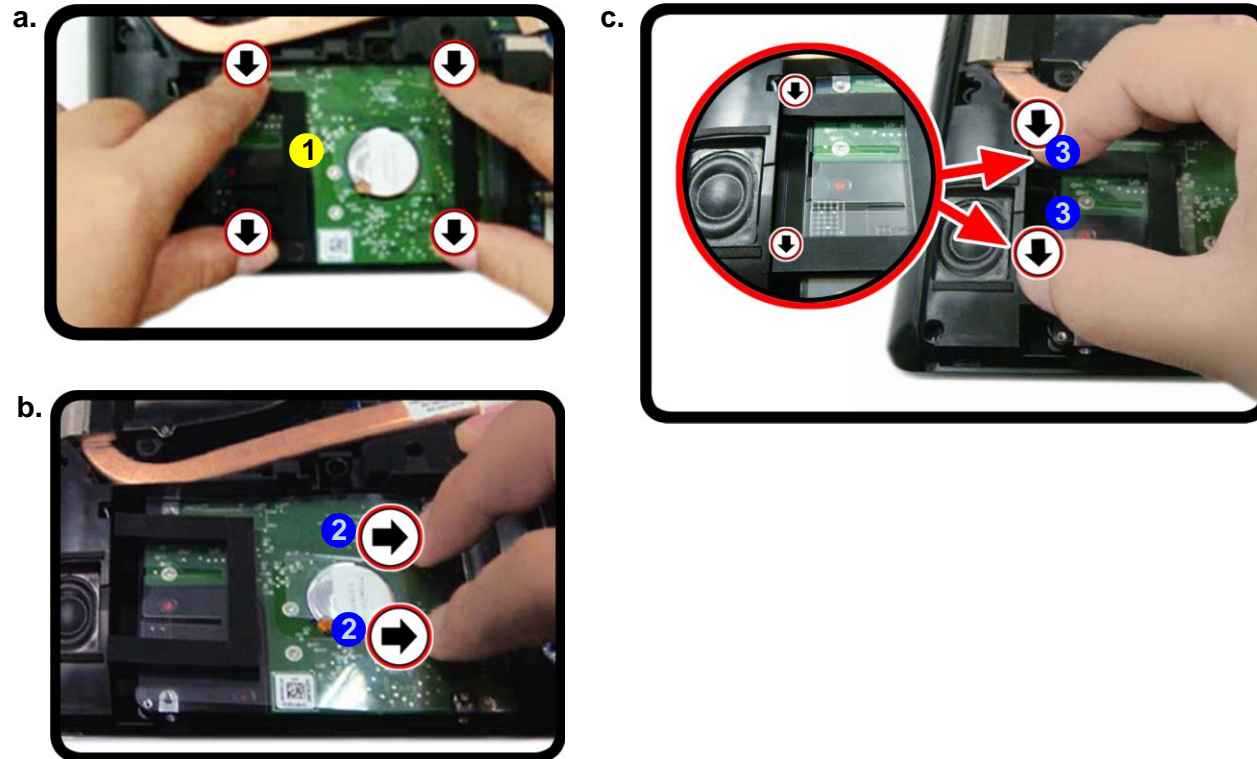

Removing the System Memory (RAM)

The computer has two memory sockets for 204 pin Small Outline Dual In-line Memory Modules (SO-DIMM) supporting DDRIII (DDR3) Up to 1333 MHz. The main memory can be expanded up to 8GB. The SO-DIMM modules supported are 1024MB and 2048MB **DDRIII** Modules. The total memory size is automatically detected by the POST routine once you turn on your computer.

Memory Upgrade Process

1. Turn **off** the computer, turn it over and remove the battery ([page 2 - 5](#)) and remove the component bay cover ([page 2 - 6](#)).
2. The RAM modules will be visible at point **1** on the mainboard.
3. Gently pull the two release latches (**2** & **3**) on the sides of the memory socket in the direction indicated by the arrows ([Figure 5b](#)). The RAM module **4** will pop-up ([Figure 5c](#)), and you can then remove it.
4. Pull the latches to release the second module if necessary.
5. Insert a new module holding it at about a 30° angle and fit the connectors firmly into the memory slot.
6. The module will only fit one way as defined by its pin alignment. Make sure the module is seated as far into the slot as it will go. **DO NOT FORCE IT**; it should fit without much pressure.
7. Press the module in and down towards the mainboard until the slot levers click into place to secure the module.
8. Replace the component bay cover (see [page 2 - 6](#)).
9. Restart the computer to allow the BIOS to register the new memory configuration as it starts up.

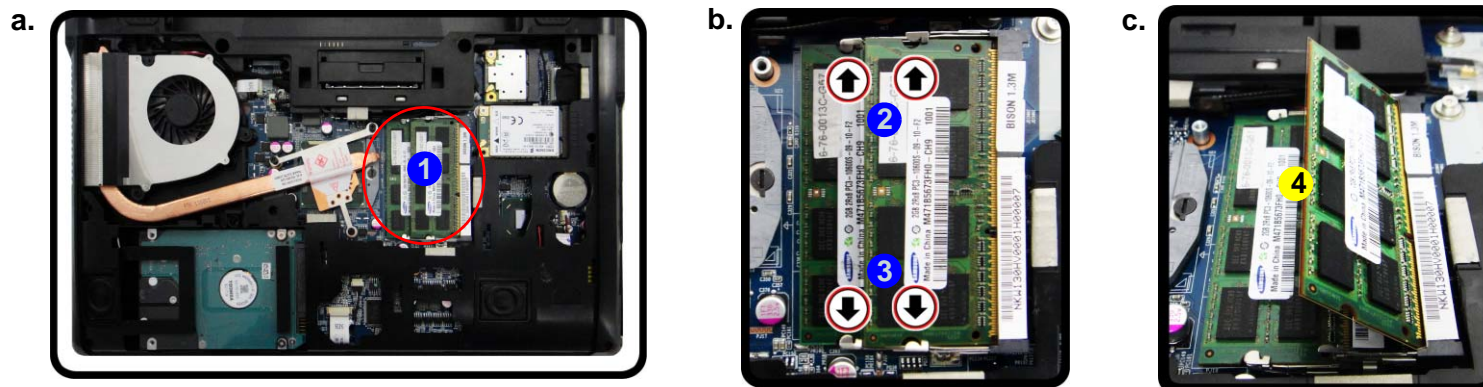

Figure 5
RAM Module Removal

- a. The RAM modules will be visible at point **1** on the mainboard.
- b. Pull the release latches.
- c. Remove the module.



Contact Warning

Be careful not to touch the metal pins on the module's connecting edge. Even the cleanest hands have oils which can attract particles, and degrade the module's performance.



4. RAM Modules

Disassembly

Figure 6
Processor Removal

- The CPU heat sink will be visible at point **A**.
- Remove the screws from the CPU heatsink.
- Grip the heat sink tab and carefully lift the heat sink up and off the computer.

Removing and Installing a Processor

Processor Removal Procedure

- Turn off the computer, turn it over, and remove the battery ([page 2 - 5](#)) and the component bay cover ([page 2 - 9](#)).
- The CPU heat sink will be visible at point **A** ([Figure 6a](#)).
- Loosen the CPU heat sink screws in the order **3**, **2** & **1** (the reverse order as indicated on the label [Figure 6b](#)).
- Grip the heat sink tab **4** and carefully raise the heat sink **5** up to an angle of around 30° and lift it up off the computer ([Figure 6c](#)).

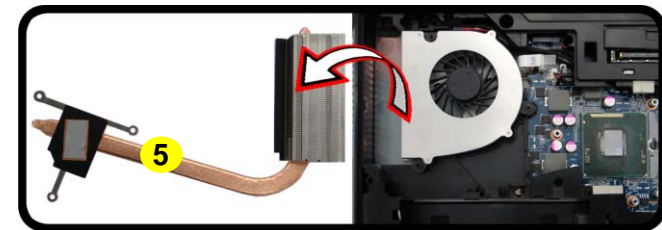
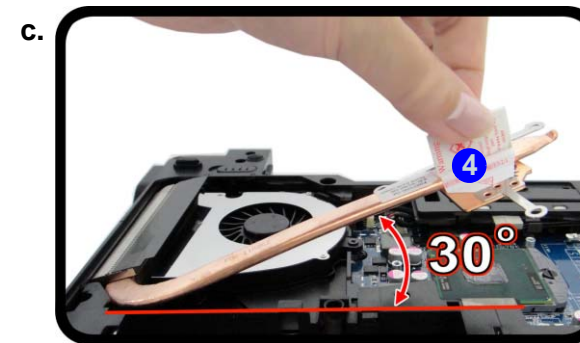
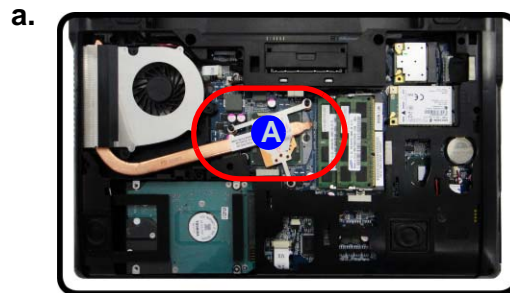

5. Heat Sink

- 3 Screws

- Turn the release latch **6** towards the unlock symbol  to release the CPU (*Figure 7d*).
- Carefully (it may be hot) lift the CPU **7** up and out of the socket (*Figure 7e*).
- Reverse the process to install a new CPU.
- When re-inserting the CPU, pay careful attention to the pin alignment, it will fit only one way (DO NOT FORCE IT!).

Figure 7
Processor Removal (cont'd)

- Turn the release latch to unlock the CPU.
- Lift the CPU out of the socket.

c.



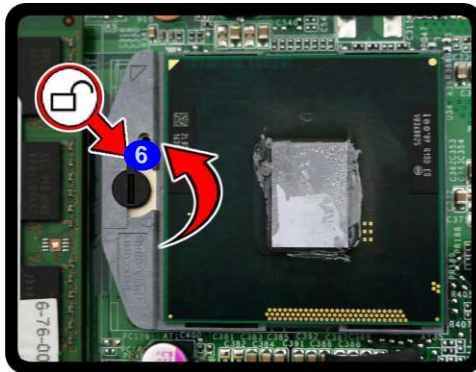

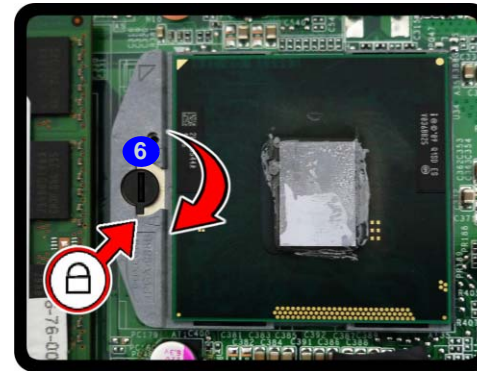
Unlock

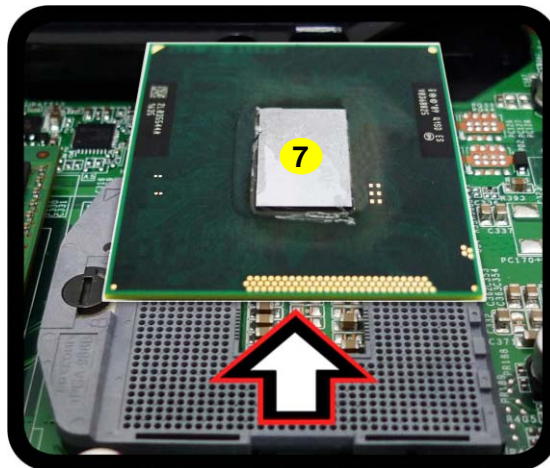

Lock

d.



Caution

The heat sink, and CPU area in general, contains parts which are subject to high temperatures. Allow the area time to cool before removing these parts.



7. CPU

Disassembly

Figure 8
Processor Installation

- Insert the CPU.
- Turn the release latch towards the lock symbol.
- Insert the heat sink.
- Tighten the screws.

Processor Installation Procedure

- Insert the CPU **A** (*Figure 8a*), pay careful attention to the pin alignment, it will fit only one way (DO NOT FORCE IT!), and turn the release latch **B** towards the lock symbol  (*Figure 8b*).
- Insert the heat sink **D** at an angle of around 30° as indicated in *Figure 8c*.
- Tighten the CPU heat sink screws in the order **1**, **2** & **3** (the order as indicated on the label and *Figure 8d*).
- Replace the component bay cover.

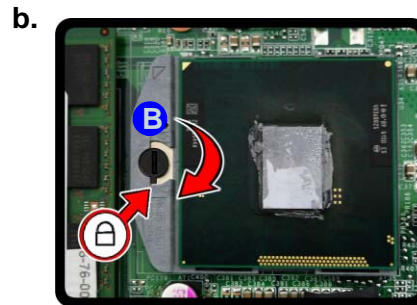
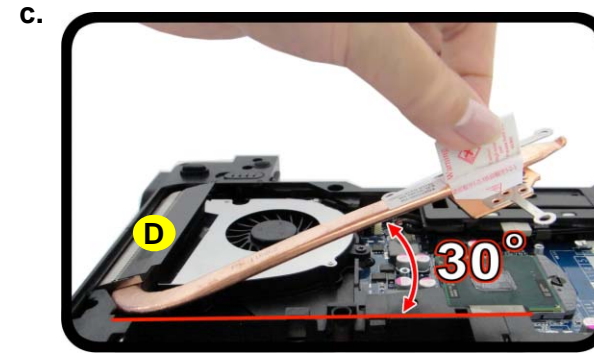
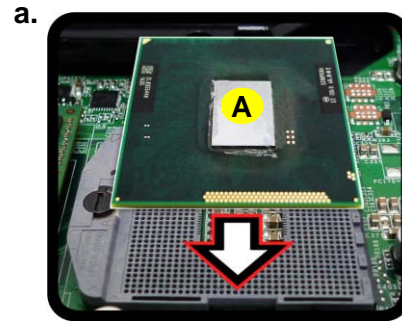

Note:
Tighten the screws
in the order as indi-
cated on the label.

- 
- A. CPU
 - D. Heat Sink
 - 3 Screws

Removing the 3.75G Module

1. Turn off the computer, turn it over, and remove the battery ([page 2 - 5](#)) and the component bay cover ([page 2 - 9](#)).
2. The 3.75G module will be visible at point **1** on the mainboard ([Figure 9a](#)).
3. Carefully disconnect the cable **2**, and then remove the screw **3** ([Figure 9b](#)).
4. The 3.75G module **4** will pop-up, and you can remove it from the computer ([Figure 9c](#)).

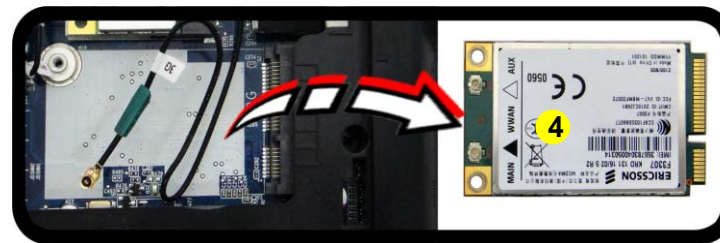
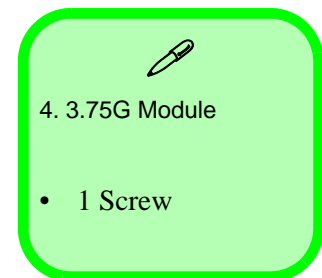

Figure 9
3G Module Removal

- Locate the 3.75G module.
- Disconnect the cable and remove the screw.
- The module will pop-up and remove the 3.75G module.

Note: Make sure you reconnect the antenna cable to socket.



Disassembly

Figure 10
**Wireless LAN
Module Removal**

- Locate the WLAN Module.
- Disconnect the cable and remove the screw.
- The WLAN module will pop up.

Note: Make sure you reconnect the antenna cable to the “1 + 2” socket (*Figure 10b*).

Removing the Wireless LAN Module

- Turn **off** the computer, turn it over, and remove the battery (*page 2 - 5*) and the component bay cover (*page 2 - 9*).
- The Wireless LAN module will be visible at point **1** on the mainboard (*Figure 10a*).
- Carefully disconnect the cables **2** - **3**, and then remove the screw **4** (*Figure 10b*).
- The Wireless LAN module **4** (*Figure 10c*) will pop-up, and you can remove it from the computer.

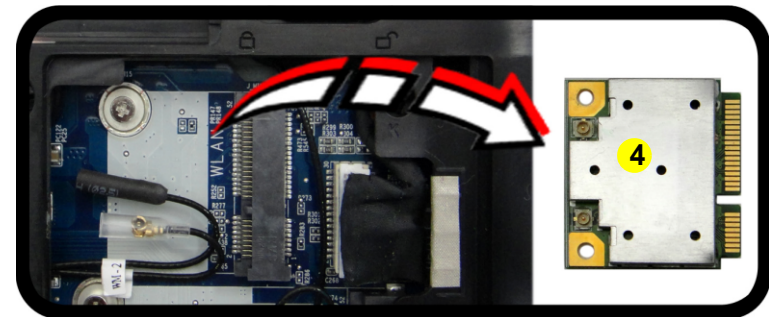
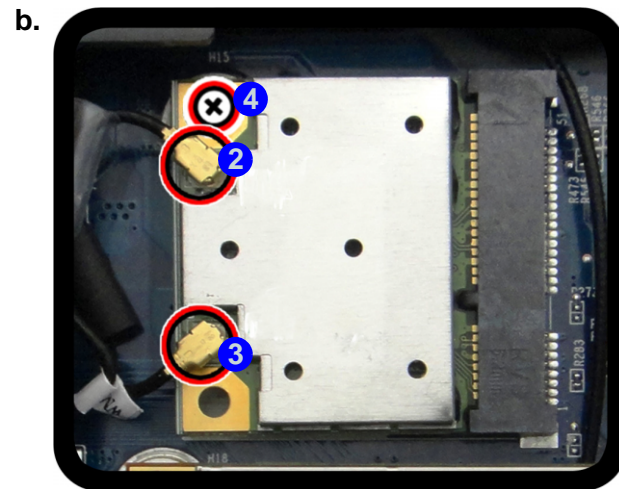
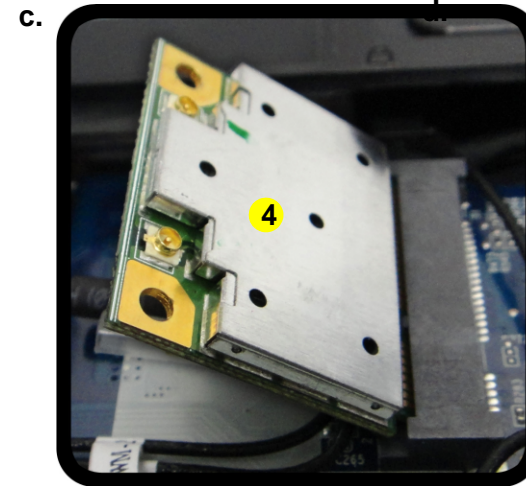
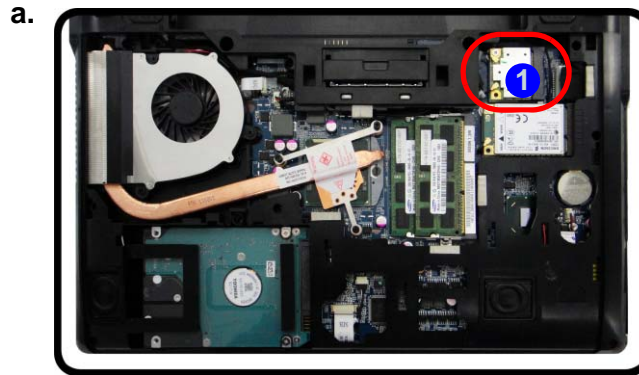

4. Wireless LAN Module

- 2 Screws

Removing the Keyboard

1. Turn **off** the computer remove the battery ([page 2 - 5](#)), and the component bay cover ([page 2 - 9](#)).
2. Remove screws **1** - **4** from the bottom of the computer.
3. Carefully raise the keyboard up, being careful not to bend the keyboard ribbon cable **5**. and remove screws **6** - **9** from the plate.
4. Remove the plate **10**.
5. Disconnect the keyboard ribbon cable **11** from the locking collar socket **12** ([Figure 11c](#))
6. Carefully lift up the keyboard **13** off the computer.

a.

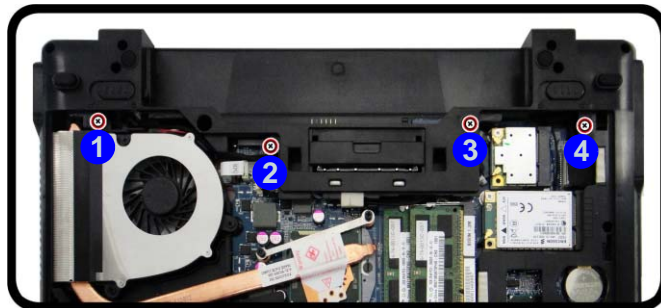

d.



b.

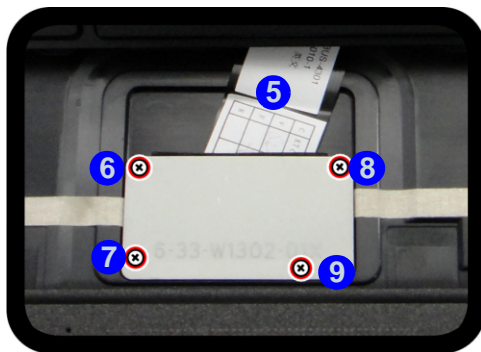

c.



e.

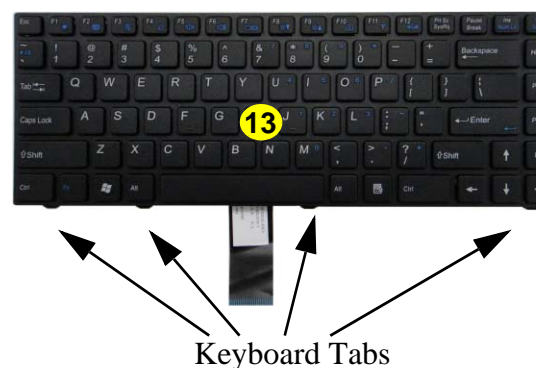

Figure 11
Keyboard Removal

- a. Remove screws from the bottom of the computer.
- b. Remove screws from the plate.
- c. Remove the plate.
- d. Carefully lift the keyboard up and disconnect the keyboard ribbon cable from the locking collar socket.
- e. Remove the keyboard.



Re-Inserting the Keyboard

When re-inserting the keyboard firstly align the **four** keyboard tabs at the bottom ([Figure 11e](#)) at the bottom of the keyboard with the slots in the case.



10. Plate for keyboard
13. Keyboard

- 8 Screws

Appendix A:Part Lists

This appendix breaks down the *W130EV / W130EW* series notebook's construction into a series of illustrations. The component part numbers are indicated in the tables opposite the drawings.

Note: This section indicates the *manufacturer's* part numbers. Your organization may use a different system, so be sure to cross-check any relevant documentation.

Note: Some assemblies may have parts in common (especially screws). However, the part lists DO NOT indicate the total number of duplicated parts used.

Note: Be sure to check any update notices. The parts shown in these illustrations are appropriate for the system at the time of publication. Over the product life, some parts may be improved or re-configured, resulting in *new* part numbers.

Part List Illustration Location

The following table indicates where to find the appropriate part list illustration.

Table A - 1
**Part List Illustration
Location**

Part	
Top	<i>page A - 3</i>
Bottom	<i>page A - 4</i>
HDD	<i>page A - 5</i>
LCD	<i>page A - 6</i>

Top

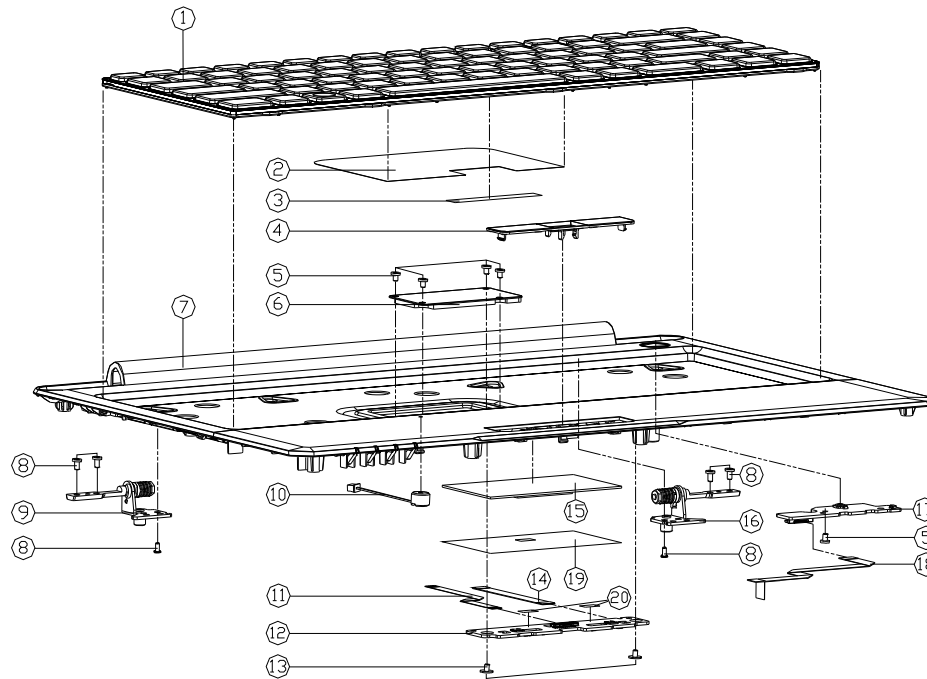
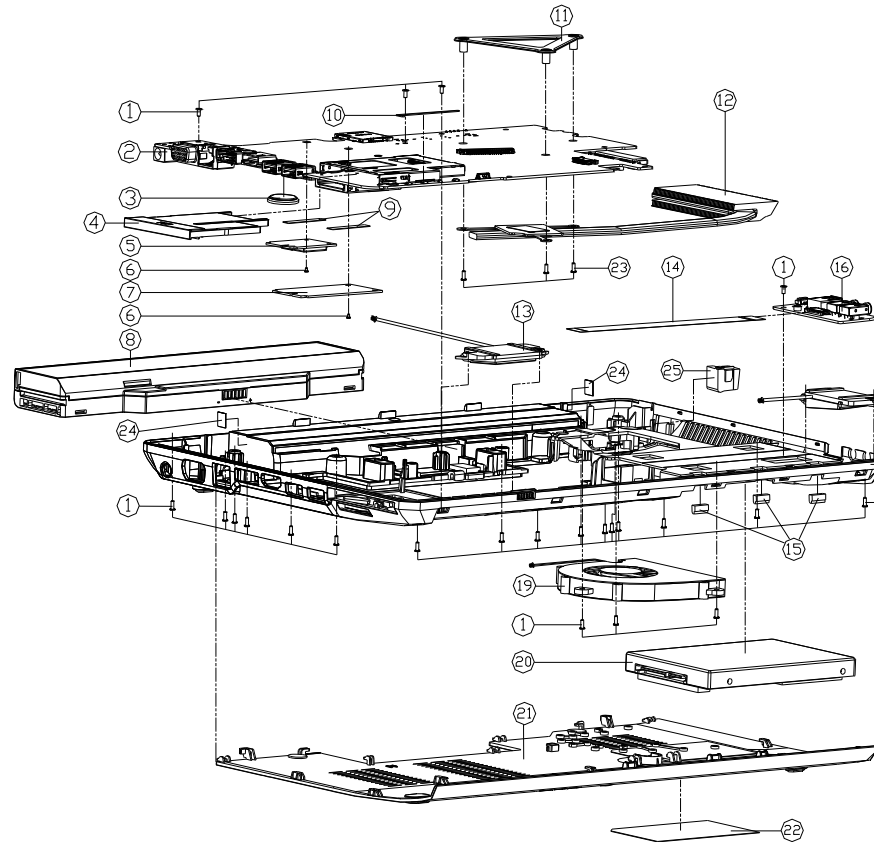

Figure A - 1
Top

ITEM	PART NAME	PART NO	REMARK
1	K/B USA (BLACK/FRAGILE) MODULE W130HUW130HV	6-79-W130HU0K-010	
2	K/B AL FOIL W130HU	6-47-W1302-010	
3	K/B MYLAR FOR WATERPROOF PET-3M467 W130HU	6-40-W1303-010	
4	CLICK BUTTON W/FINGER PC+ABS W130HU	6-42-W1302-031	
5	SCREW M2*3L KI NI ICT NY (DD=045,DT=04)	6-35-B1120-3RE	
6	PLATE FOR KEYBOARD SECC+CR4305 W130HU	6-33-W1302-010	
7	TDP CASE MODULE(CHANGE) W130HU	6-39-W1302-014	
8	SCREW M2.5*6L K BZ ICT NY	6-35-82125-6RA	
9	HINGE L K7 (CHANGE) W130HU	6-33-W1302-031	
10	ME GUNSCREWSTFL-0 INVEY 22X W08L09 L-8MM W08L (L080)	6-23-EM55G-011-2	
11	FFC CABLE FOR TOUCH PAD TO CLICK BOARD (TP V040)	6-43-W04T2-012-1	
12	CLICK BOARD V2.0A W130EW	6-77-W1302-D02A-A	
13	SCREW M2*2L KI BK/Z ICT NY(08,T=0.6)	6-35-B6120-2RE	
14	FFC CABLE FOR CLICK BOARD TO M0 TOPIN (CLUS) W130HU	6-43-W1300-010-1	
15	TOUCH PAD SYNAPTICS TM-00450-013 MULTI-GESTURE	6-49-W2103-010	
16	HINGE R K7(CHANGE) W130HU	6-33-W1302-021	
17	POWER SWITCH BOARD V2.0 W130EW	6-77-W130S-D02-A	
18	FFC CABLE FOR POWER BOARD TO M0 TOPIN (CLUS) W130HU	6-43-W1300-021-1	
19	MYLAR (68*25*0.25T) FOR TOUCH PAD W130HU	6-40-00150-6B2	
20	TDP CASE MYLAR FR83 25*7*0.05 P180HM	6-40-P1802-030	

Bottom

Figure A - 2
Bottom



ITEM	PART NAME	PART NO	REMARK
1	SCREW M2.5*6L K BZ ICT NY	6-35-82125-6RA	
2	MAIN BOARD V20 (W/3G W/MDC) W130EW	6-77-W13W0-D02	
2	MAIN BOARD V20 (W/D 3G W/D MDC) W130EW	6-77-W13W0-D02-1	
2	MAIN BOARD V20 (W/3G W/MDC) W130EW	6-77-W13E0-D02	
2	MAIN BOARD V20 (W/D 3G W/D MDC) W130EW	6-77-W13E0-D02-1	
3	BATTERY 3V Z10MA CR2032 (MITSUBISHI)	6-23-62015-607	
4	DUMMY NEW CARD PC+ABS INLEZOR (6.0.0)	6-42-T12R3-011-2	
5	LED LENS SPONGE W130HU	6-88-W345F-9400	<OPTION>
5	LED LENS SPONGE W130HU	6-88-W25H2-9400	<OPTION>
5	LED LENS SPONGE W130HU	6-88-P17EF-4200	<OPTION>
5	LED LENS SPONGE W130HU	6-88-P170F-4210	<OPTION>
5	LED LENS SPONGE W130HU	6-88-W345F-8700	<OPTION>
5	LED LENS SPONGE W130HU	6-88-W110F-4200	<OPTION>
5	LED LENS SPONGE W130HU	6-88-P1702-4200	<OPTION>
6	SCREW M2*CL KI NI ICT NY (00-44.5DT-04)	6-35-B1120-3RE	
7	WORM ERICSSON F3207 HSPA FULL MINI-CARD USB	6-88-W24HW-2410	<OPTION>
8	MIPS SU TINYSAFE250W 250W 250W 250W 250W	6-87-W130S-4D71	<OPTION>
9	TAPE MYLAR TRANSPARENT (20*10*0.05) P180M	6-40-P1803-020	
10	LED LENS SPONGE W130HU	6-47-W130S-010	
11	CPU SUPPORTER FOR HARD RIVER SECC W150HM	6-33-W150S-011	
12	CPU HEATSINK MODULE W130HU	6-31-W130N-101	
13	SPRING L 47A84 27V 41.5MM PRECISION-AL V100U	6-23-5W130-0L0	
14	FTC CABLE FOR MB TO AUDIO BOARD 20PIN (0.8)	6-43-W15HS-010-1	
15	BOTTOM CASE HD RUBBER (0.8*0.8) SILICONE V130HU	6-47-W1303-051	
16	AUDIO BOARD V2.0A W130HU	6-77-W1308-D02A	
17	SPRING 8 45*40 27V 41.5MM PRECISION-AL V100U	6-23-5W130-0R1	
18	BOTTOM CASE MODULE W130HU	6-39-W1303-013	
19	FAN MODULE W150HNM	6-23-AV150-100	
20	W/HDD ASSY W130HU/W130HV	6-79-W130HUJ-010	
20	W/D HDD ASSY W130HU/W130HV	6-79-W130HUJ-080	
21	CPU COVER MODULE W130HU	6-42-W1308-102	
21	PRODUCT LABEL FOR W130EW	6-45-W130EW03-010	
22	PRODUCT LABEL FOR W130EV	6-45-W130EV03-010	
23	SCREW M2.5*4L F NI ICT NY	6-35-21125-4R0	
24	MYLAR (15*6*0.6T) FOR M77X	6-40-M7703-010	
25	RJ45 DUMMY RUBBER KE-5612GU W130HU	6-47-W1303-011	

HDD

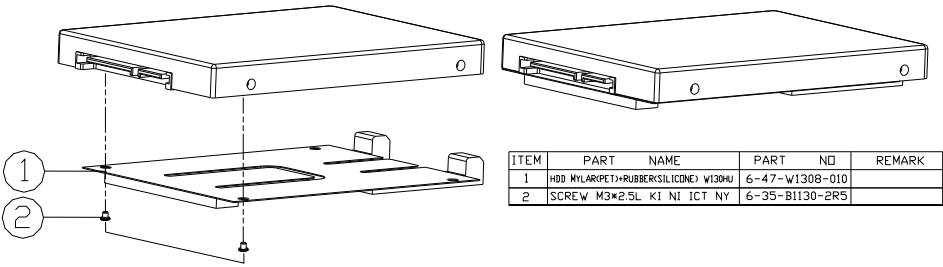
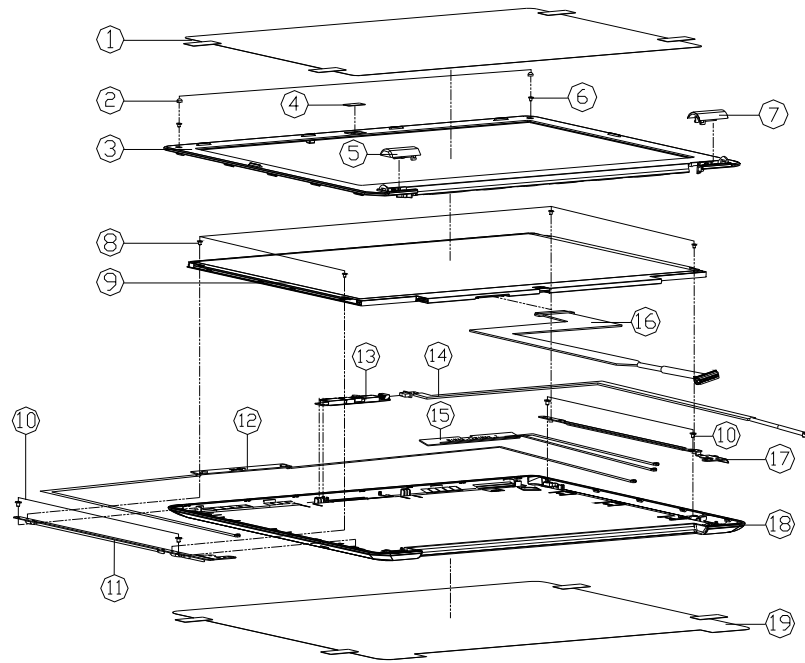

Figure A - 3
HDD



LCD

Figure A - 4
LCD



ITEM	PART NAME	PART NO.	REMARK
1	LCD FRONT COVER PROTECT FILM PET W830T	6-40-W83T1-011	
2	RUBBER CHANGED FOR FRONT COVER SCREW W830T	6-47-W83T1-061	
3	SPRING FOR FRONT COVER SCREW W830T	6-78-W83T1-001	
4	CCD MYLAR PC8010 W840T	6-40-W84TT-011	w/ CCD
4	W/D CCD MYLAR PC8010 W840T	6-40-W84TT-020	w/D CCD
5	LCD HINGE COVER L PC+ABS W130HU	6-42-W1301-020	
6	SCREW M2*3L I BK/Z ICT NY	6-35-C6120-3R0	
7	LCD HINGE COVER R PC+ABS W130HU	6-42-W1301-010	
8	SCREW M1.6*2L D=32 T=0.4 KI BZ ICT NY	6-35-B2116-2R0	
9	LCD 13.3" HD CHIMEI N133DE-L46 GLARE TYPE QLED 300M	6-50-G8136-DD1	
9	LCD 13.3" HD LG LP133W42-T1L2 GLARE TYPE QLED 300M	6-50-G8136-L00	
9	LCD 13.3" HD LG LP133W42-T1L2R GLARE TYPE	6-50-G8135-L00	
9	LCD 13.3" HD TOSHIBA LT133DEPR100 GLARE TYPE	6-50-G8136-T00	
9	LCD 13.3" HD CHIMEI N133DE-L31 QLED 300M	6-50-G8136-D00	
10	SCREW M2*3L KI NI ICT NY 100-445.01-044	6-35-B1120-3RE	
11	LCD BKT L SECC 0.5T W830T	6-33-W83T1-022	
12	WIRE CABLE FOR LVDS 26PIN ALU/AL COVER/BEZEL/COVER W830T	6-23-7W130-020	
13	UV-CAMERA COVER FOR BEZEL/300 FOR FRONT W830T	6-88-W25CC-4900	
13	UV-CAMERA COVER FOR DISPLAY FOR FRONT W830T	6-88-W25UC-5100	
13	UV-CAMERA RESIN FOR BEZEL/300 FOR BACK W830T	6-88-E510C-4904	
14	WIRE CABLE FOR CCD SP 494MM W130HU 04L	6-43-W130T-010	
15	WIRE CABLE FOR LVDS 26PIN ALU/AL COVER/BEZEL/COVER W830T	6-23-7W130-010	
16	WIRE CABLE FOR LVDS 26PIN ALU/AL COVER/BEZEL/COVER W830T	6-43-W1301-011-K	
17	LCD BKT R SECC 0.5T W830T	6-33-W83T1-012	
18	LCD BACK COVER MIDDLE/COEL RIBS W130HU	6-39-W1301-021	
19	LCD BACK COVER PET T=0.025MM W831T	6-40-W83T1-040	

Appendix B: Schematic Diagrams

This appendix has circuit diagrams of the *W130EV / W130EW* notebook's PCB's. The following table indicates where to find the appropriate schematic diagram.

Diagram - Page	Diagram - Page	Diagram - Page
<i>System Block Diagram - Page B - 2</i>	<i>PCH 5/9 - Page B - 19</i>	<i>5VS, 3VS, 1.5VS CPU - Page B - 36</i>
<i>Processor 1/7 - Page B - 3</i>	<i>PCH 6/9 - Page B - 20</i>	<i>Power 1.5V/0.75V,1.8VS - Page B - 37</i>
<i>Processor 2/7 - Page B - 4</i>	<i>PCH 7/9 - Page B - 21</i>	<i>VDD3, VDD5 - Page B - 38</i>
<i>Processor 3/7 - Page B - 5</i>	<i>PCH 8/9 - Page B - 22</i>	<i>POWER 1.05V LAN_M - Page B - 39</i>
<i>Processor 4/7 - Page B - 6</i>	<i>PCH 9/9 - Page B - 23</i>	<i>POWER 0.85VS - Page B - 40</i>
<i>Processor 5/7 - Page B - 7</i>	<i>NEW CARD, MINI PCIE - Page B - 24</i>	<i>Power V-CORE 1 - Page B - 41</i>
<i>Processor 6/7 - Page B - 8</i>	<i>CCD, 3G - Page B - 25</i>	<i>Power V-CORE 2 - Page B - 42</i>
<i>Processor 7/7 - Page B - 9</i>	<i>TPM, HDD, USB3.0 CONN + PWR - Page B - 26</i>	<i>CHARGE, DC IN - Page B - 43</i>
<i>DDR3 SO-DIMM_0 - Page B - 10</i>	<i>KBC-ITE IT8518 - Page B - 27</i>	<i>CLICK BOARD / FG - Page B - 44</i>
<i>DDR3 SO-DIMM_1 - Page B - 11</i>	<i>LED, MDC - Page B - 28</i>	<i>AUDIO BOARD/ USB, HP, MIC - Page B - 45</i>
<i>LVDS, INVERTER - Page B - 12</i>	<i>AUDIO CODEC VIA VT1802P - Page B - 29</i>	<i>POWER SWITCH - Page B - 46</i>
<i>HDMI - Page B - 13</i>	<i>POWER CON, FAN, TP, CLICK CON - Page B - 30</i>	<i>DEBUG BOARD - Page B - 47</i>
<i>CRT - Page B - 14</i>	<i>DOCKING CONNECTOR, COM PORT - Page B - 31</i>	<i>Power Sequence - Page B - 48</i>
<i>PCH 1/9 - Page B - 15</i>	<i>AUDIO CONN, ESATA+USB+CHR - Page B - 32</i>	
<i>PCH 2/9 - Page B - 16</i>	<i>CARD READER JMC389 - Page B - 33</i>	
<i>PCH 3/9 - Page B - 17</i>	<i>LAN (INTEL LAN82579) - Page B - 34</i>	
<i>PCH 4/9 - Page B - 18</i>	<i>INTEL LAN 82579LM - Page B - 35</i>	

Table B - 1
**SCHEMATIC
DIAGRAMS**



Version Note

The schematic diagrams in this chapter are based upon version 6-7P-W13E5-002. If your mainboard (or other boards) are a later version, please check with the Service Center for updated diagrams (if required).

System Block Diagram

Sheet 1 of 47
System Block
Diagram

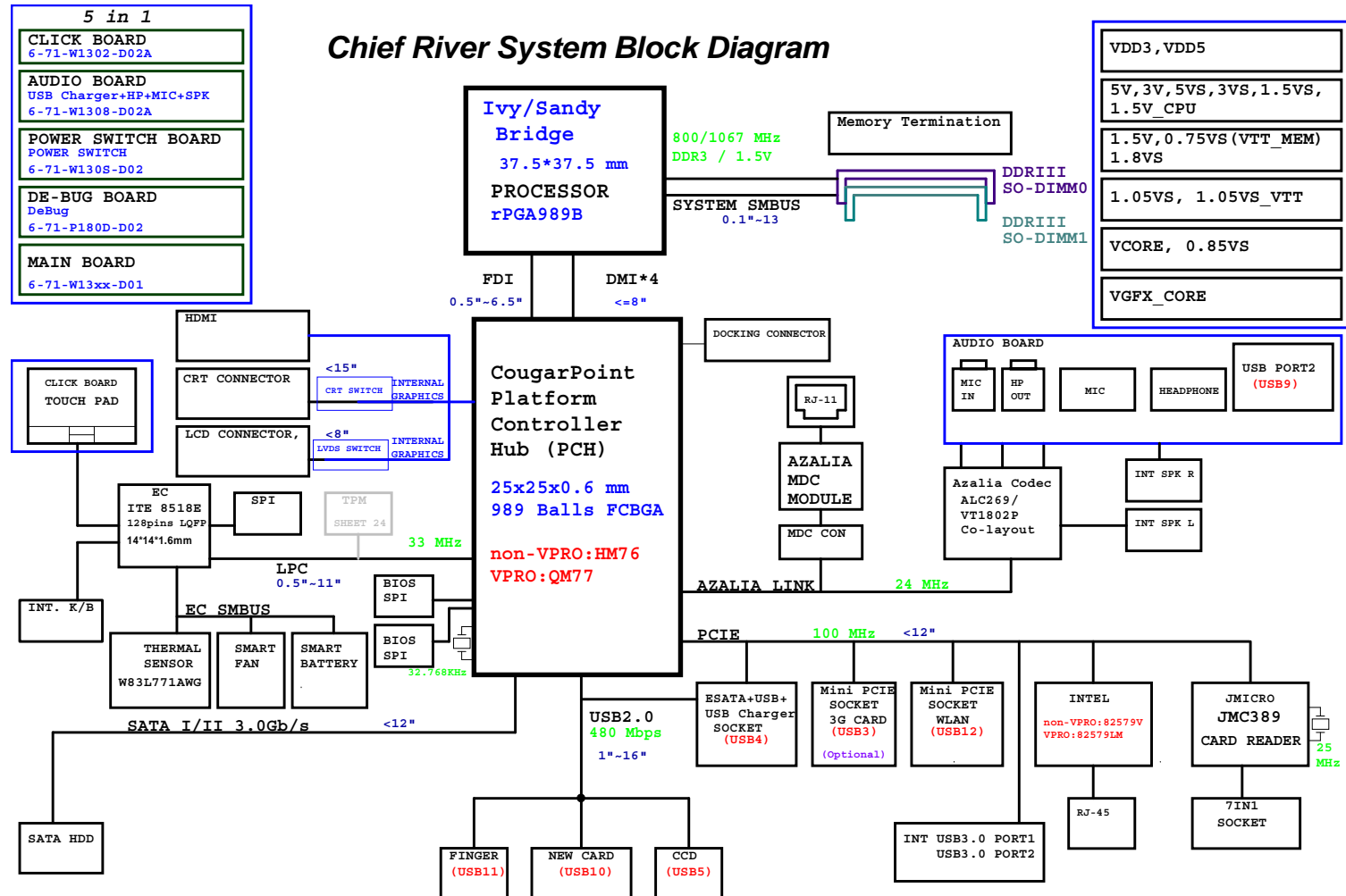

Processor 2/7

Sheet 3 of 47
Processor 2/7

Ivy/Sandy Bridge Processor 2/7 (CLK,MISC,JTAG)

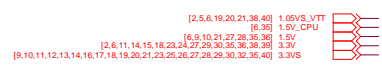
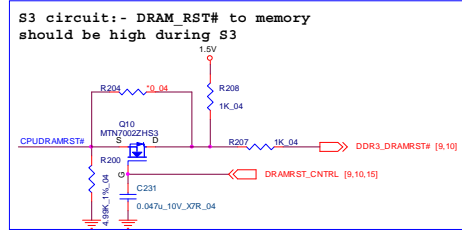
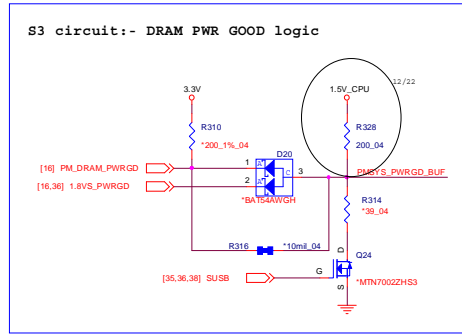
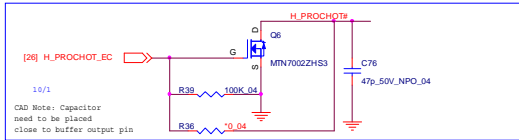
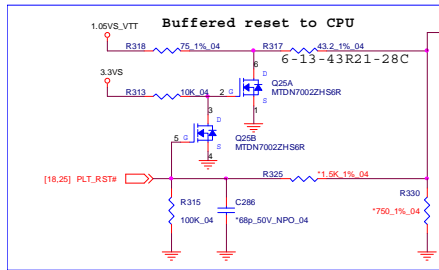
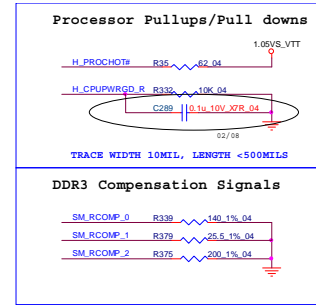
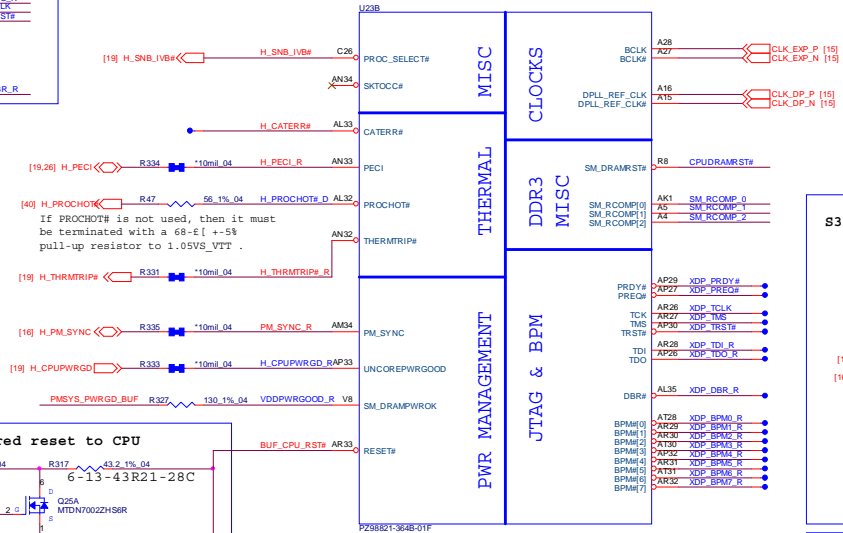
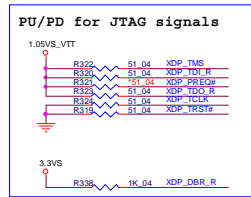

Processor 3/7

Ivy/Sandy Bridge Processor 3/7 (DDR3)

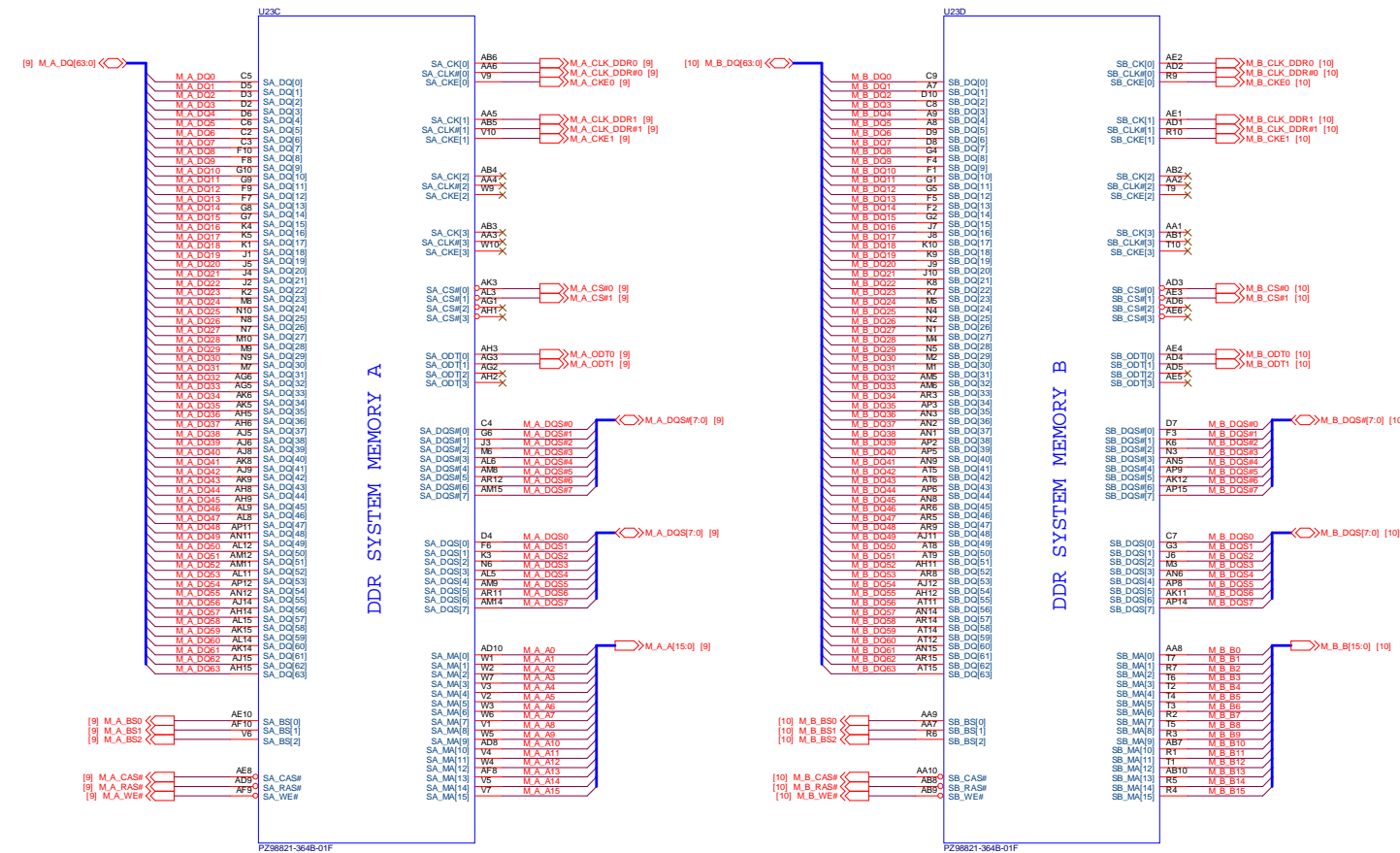

Sheet 4 of 47
Processor 3/7

B.Schematic Diagrams

Processor 4/7

Ivy/Sandy Bridge Processor 4/7

Sheet 5 of 47
Processor 4/7

PROCESSOR CORE POWER
ICCMAX Maximum Processor SV 48

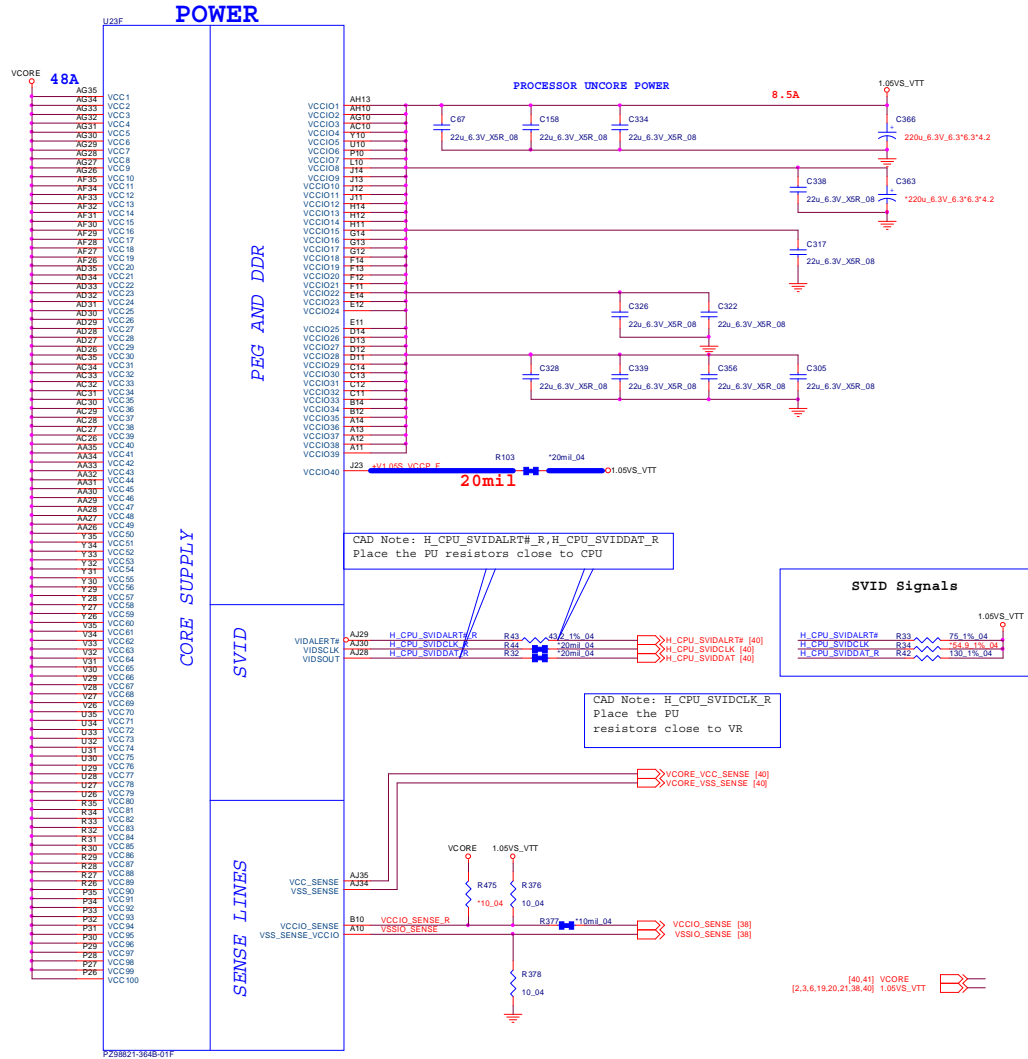
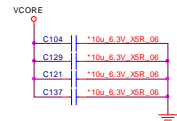
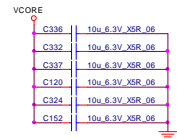
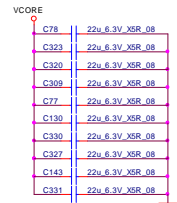

Processor 5/7

Ivy/Sandy Bridge Processor 5/7 (GRAPHICS POWER)

Sheet 6 of 47
Processor 5/7

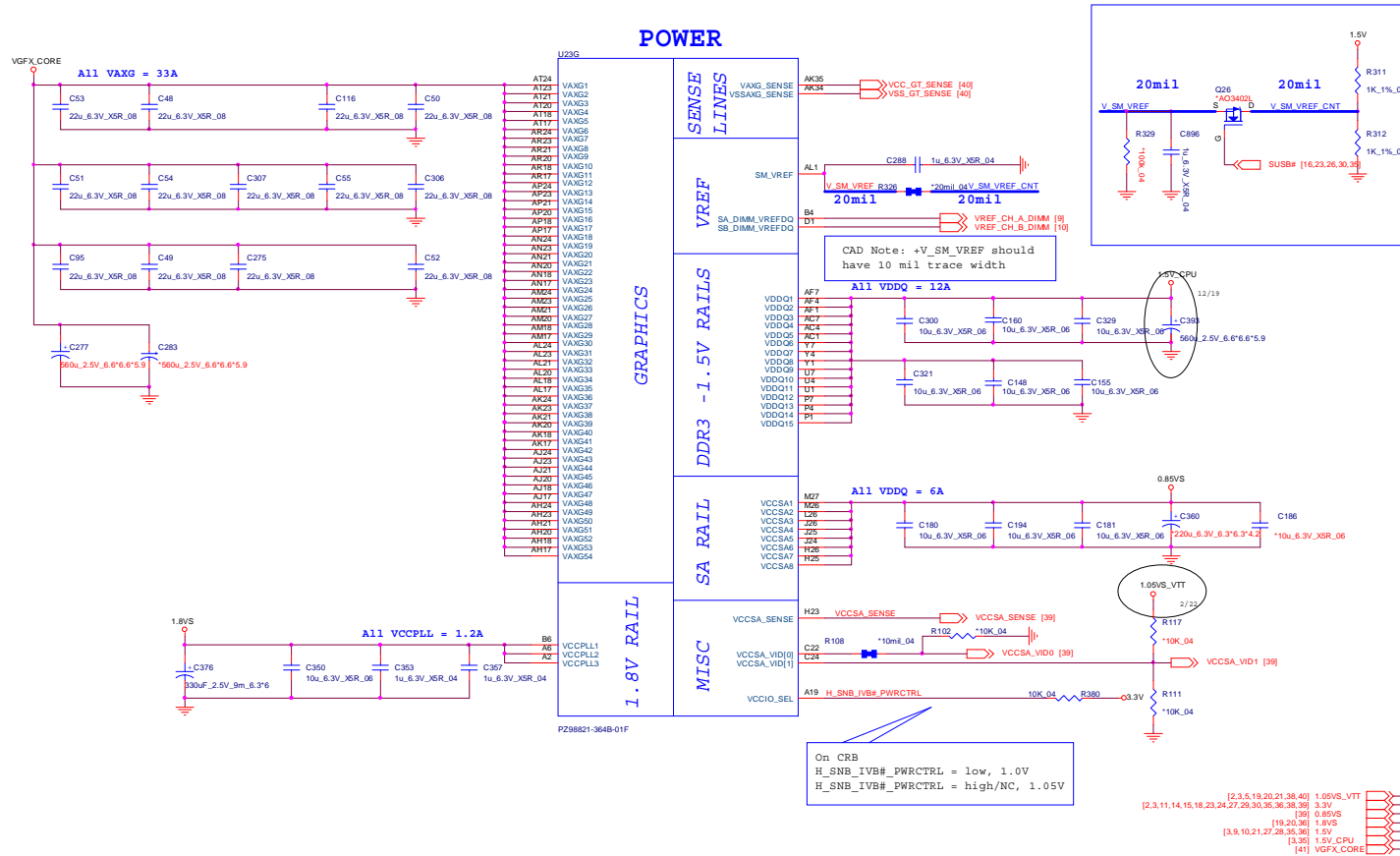

Processor 6/7

Ivy/Sandy Bridge Processor 6/7 (GND)

Sheet 7 of 47
Processor 6/7

CAD Note: 0 ohm resistor should be placed close to CPU

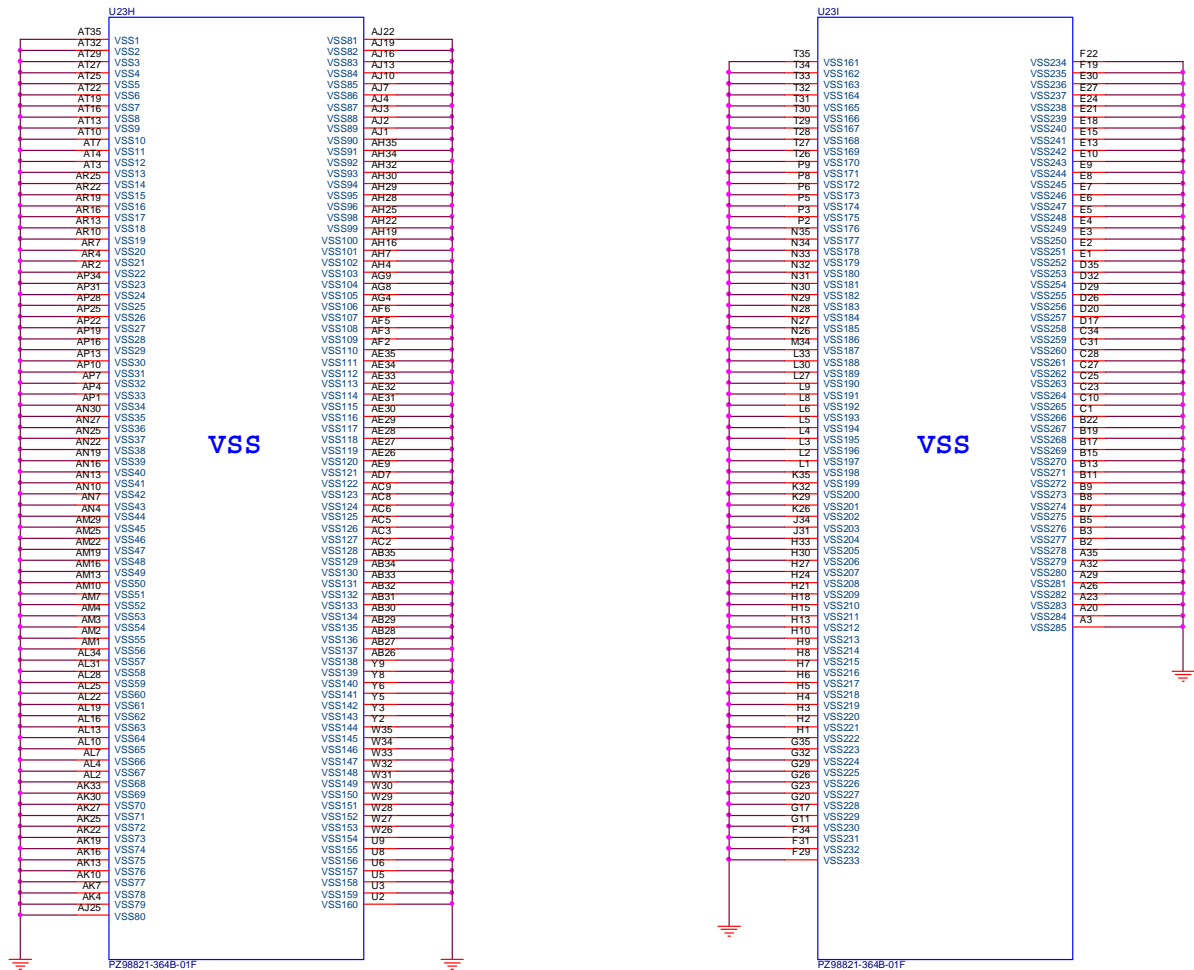

Processor 7/7

Ivy/Sandy Bridge Processor 7/7 (RESERVED)

CFG Straps for Processor

PEG Static Lane Reversal - CFG2 is for the 16x

CFG2	1: (Default) Normal Operation; Lane # definition matches socket pin map definition 0: Lane Reversed
------	--

Display Port Presence Strap

CFG4	1: (Default) Disabled; No Physical Display Port attached to Embedded Display Port 0: Enabled; An external Display Port device is connected to the Embedded Display Port
------	--

PCIe Port Bifurcation Straps

CFG [6 : 5]	11: (Default) x16 - Device 1 functions 1 and 2 disabled 10: x8, x8 - Device 1 function 1 enabled ; function 2 disabled 01: Reserved - (Device 1 function 1 disabled ; function 2 enabled) 00: x8,x4,x4 - Device 1 functions 1 and 2 enabled
-------------	--

PEG DEFER TRAINING

CFG7	1: (Default) PEG Train immediately following xxRESETB de assertion 0: PEG Wait for BIOS for training
------	---

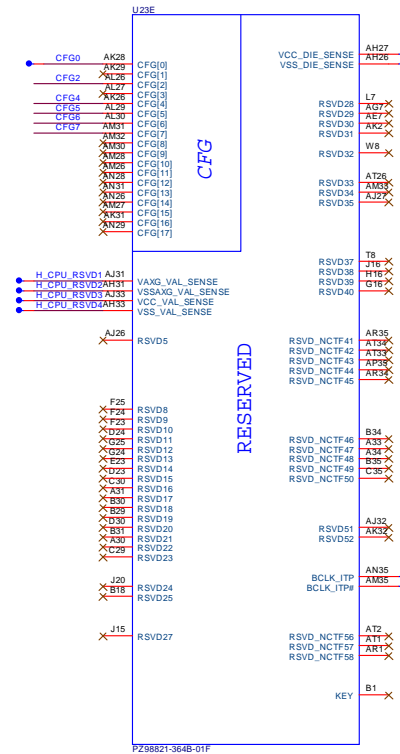

PZ98621-364B-01F

[3,6,9,10,21,27,28,35,36] 1.5V
[2,3,6,11,14,15,18,23,24,27,29,30,35,36,38,39] 3.3V

B.Schematic Diagrams

Sheet 8 of 47
Processor 7/7

DDR3 SO-DIMM_1

SO-DIMM B

CHANGE TO STANDARD

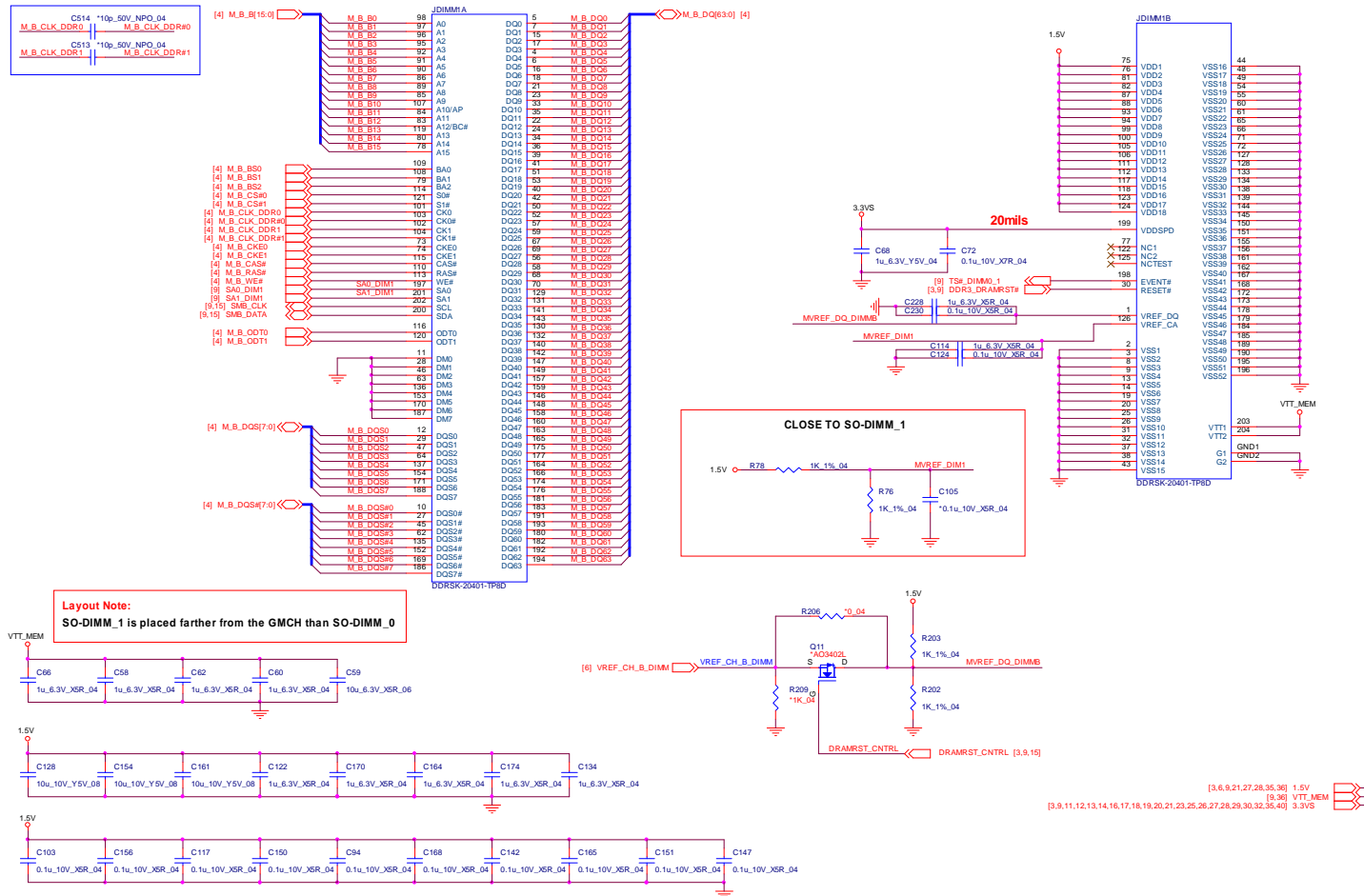

Sheet 10 of 47
DDR3 SO-DIMM_1

B.Schematic Diagrams

LVDS, INVERTER

PANEL CONNECTOR

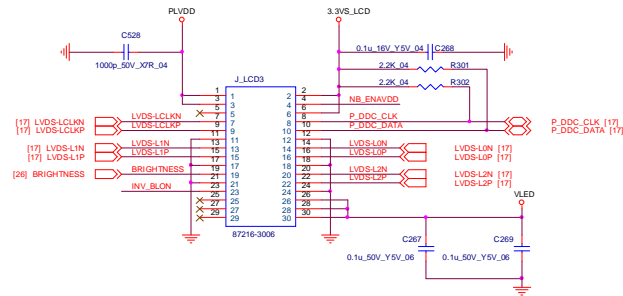

LED PANEL (LVDS Dual Channel).

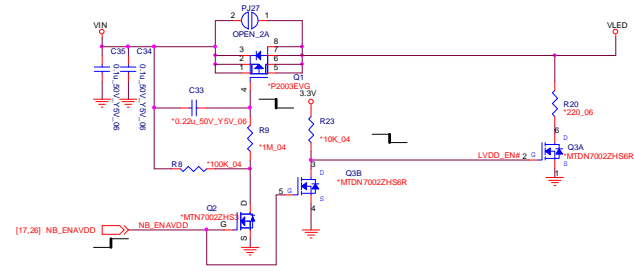

LCD Power Switch G5243A

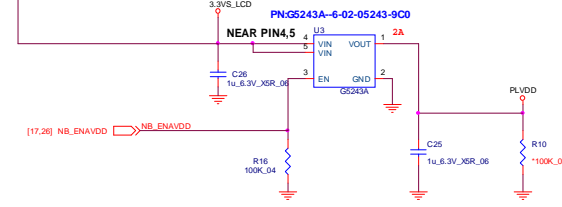

∅40pin connector@E, -nsN30pin connector@F, @T@wpin pad, U@OJKz¼

INVERTER CONNECTOR

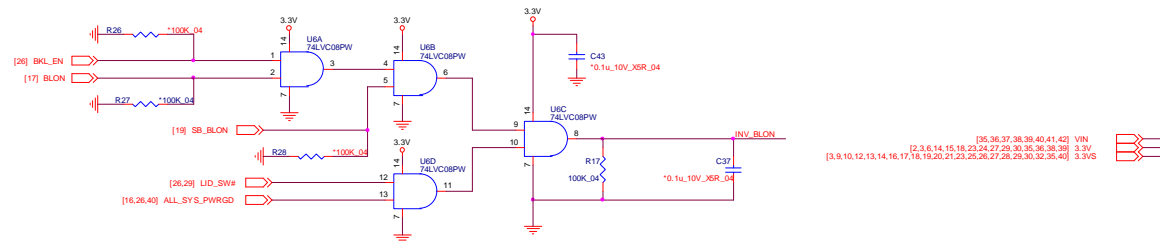

[35,36,37,38,39,40,41,42] VIN
[2,3,6,14,15,18,23,24,27,28,30,35,36,38,39] 3.3V
[3,8,10,12,13,14,16,17,18,19,20,21,22,25,26,27,28,29,30,32,35,40] 3.3V

B.Schematic Diagrams

Sheet 11 of 47
LVDS, INVERTER

Schematic Diagrams

CRT

CRT PORT

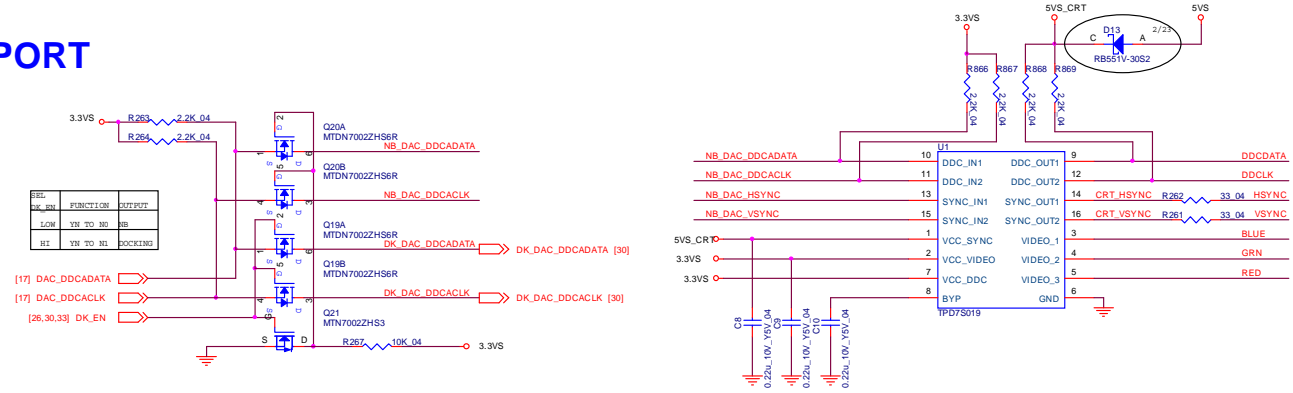

Sheet 13 of 47
CRT

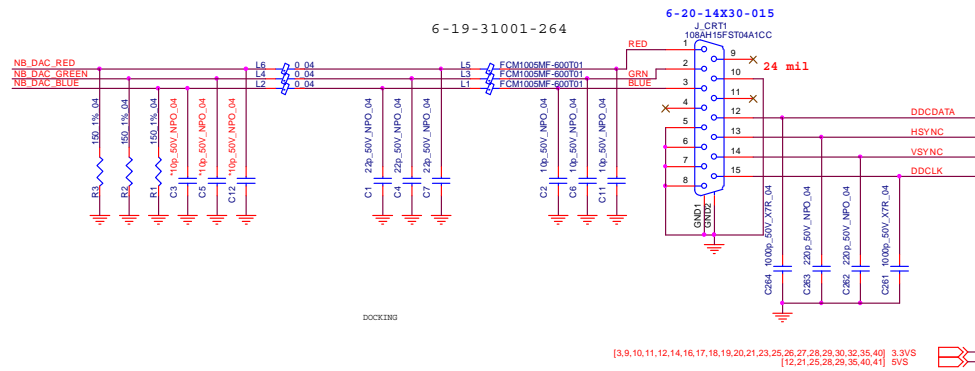
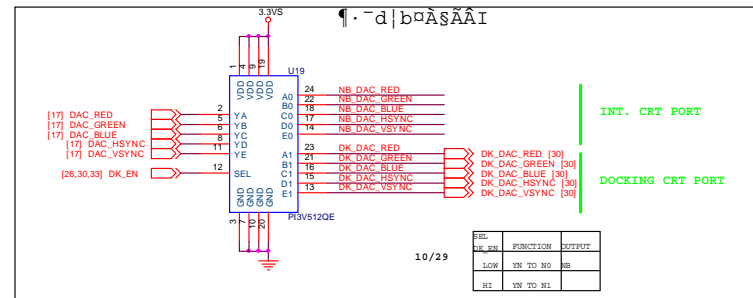

PCH 1/9

PantherPoint - M (HDA, JTAG, SATA)

6-03-08265-080

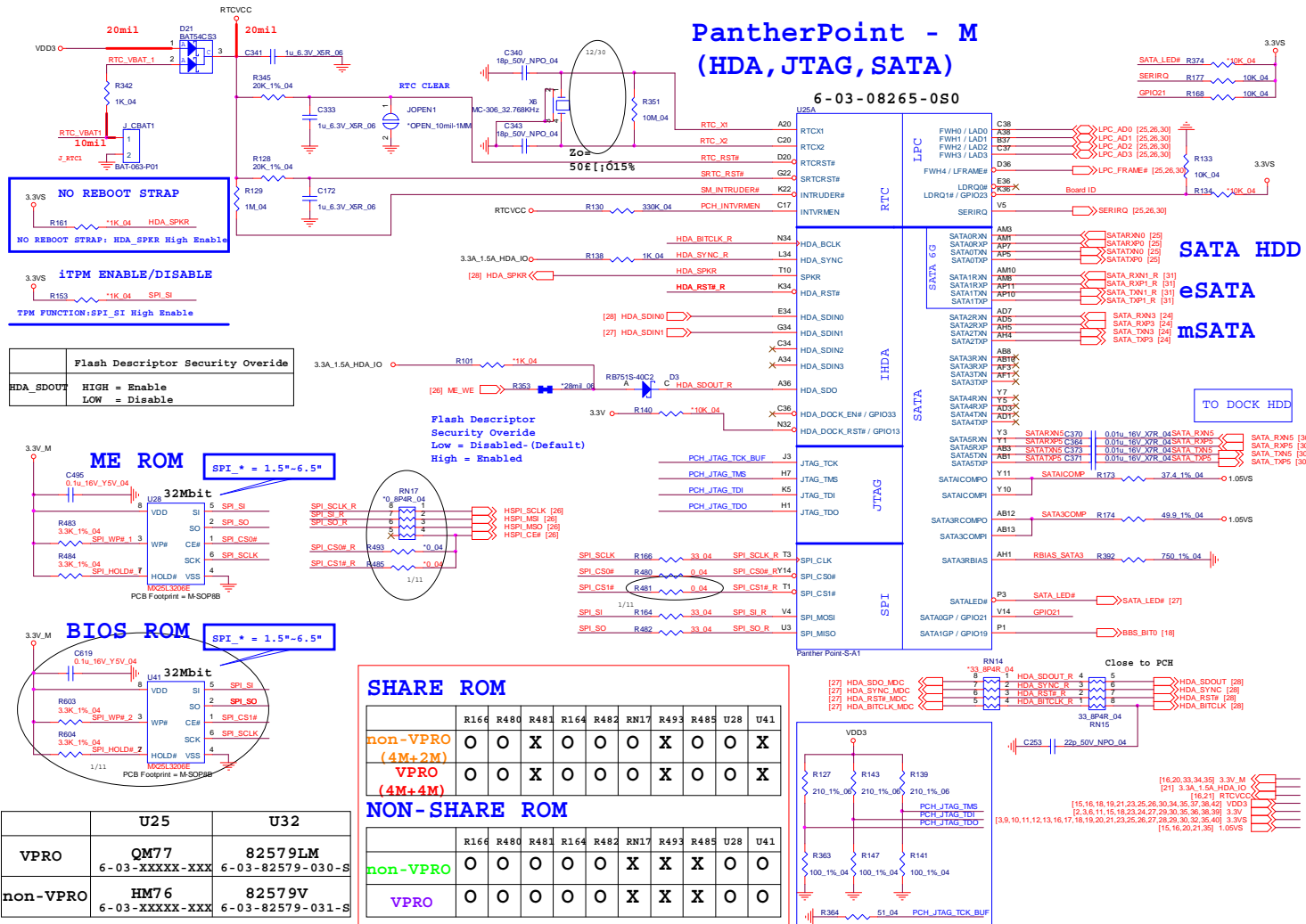

Sheet 14 of 47
PCH 1/9

PCH 2/9

Sheet 15 of 47
Cougar Point M 2/9

PantherPoint - M (PCI-E, SMBUS, CLK)

6-03-08265-0S0

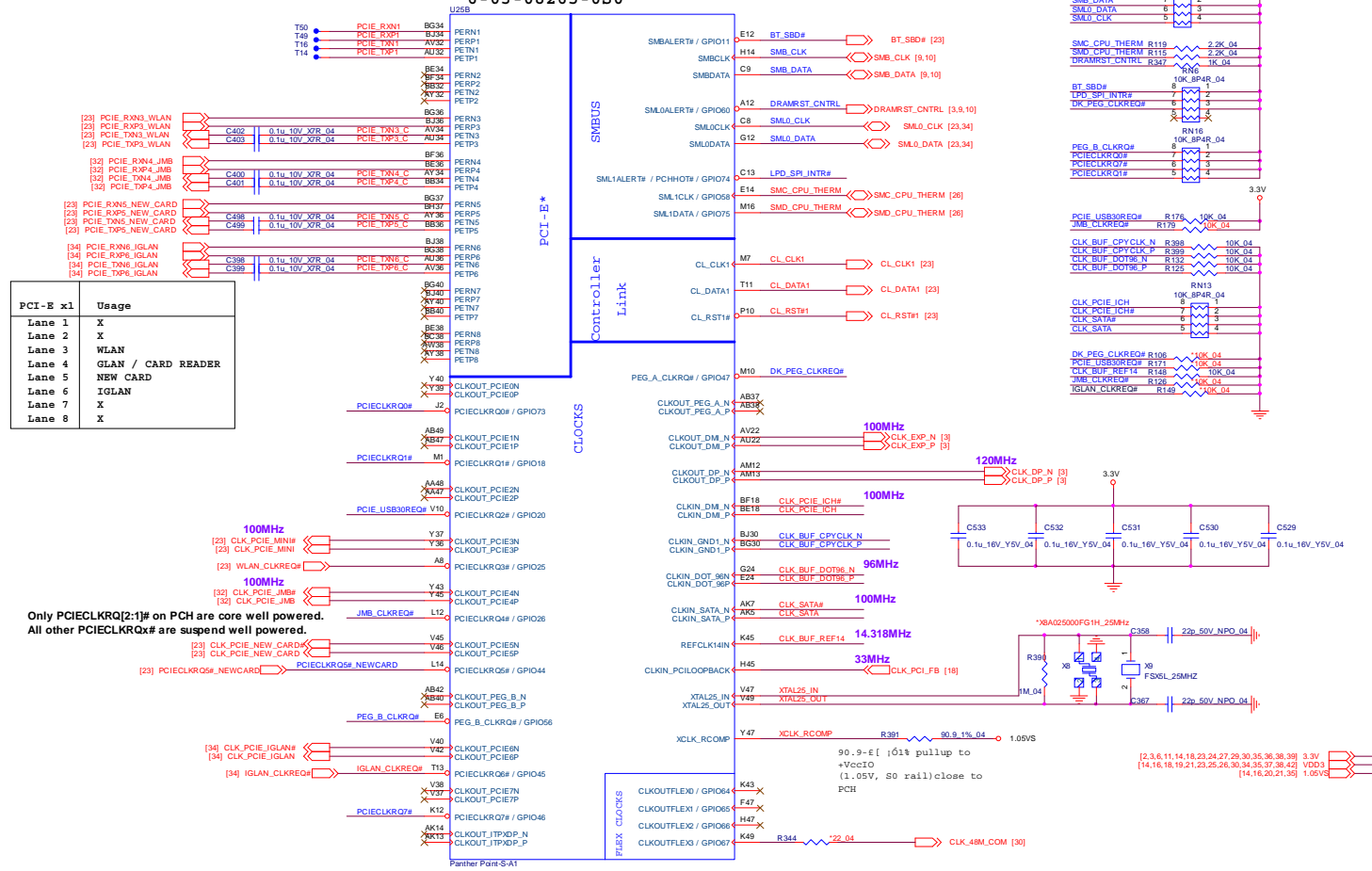

PCH 4/9

Sheet 17 of 47
PCH 4/9

PantherPoint -M
(LVDS, DDI, CRT)

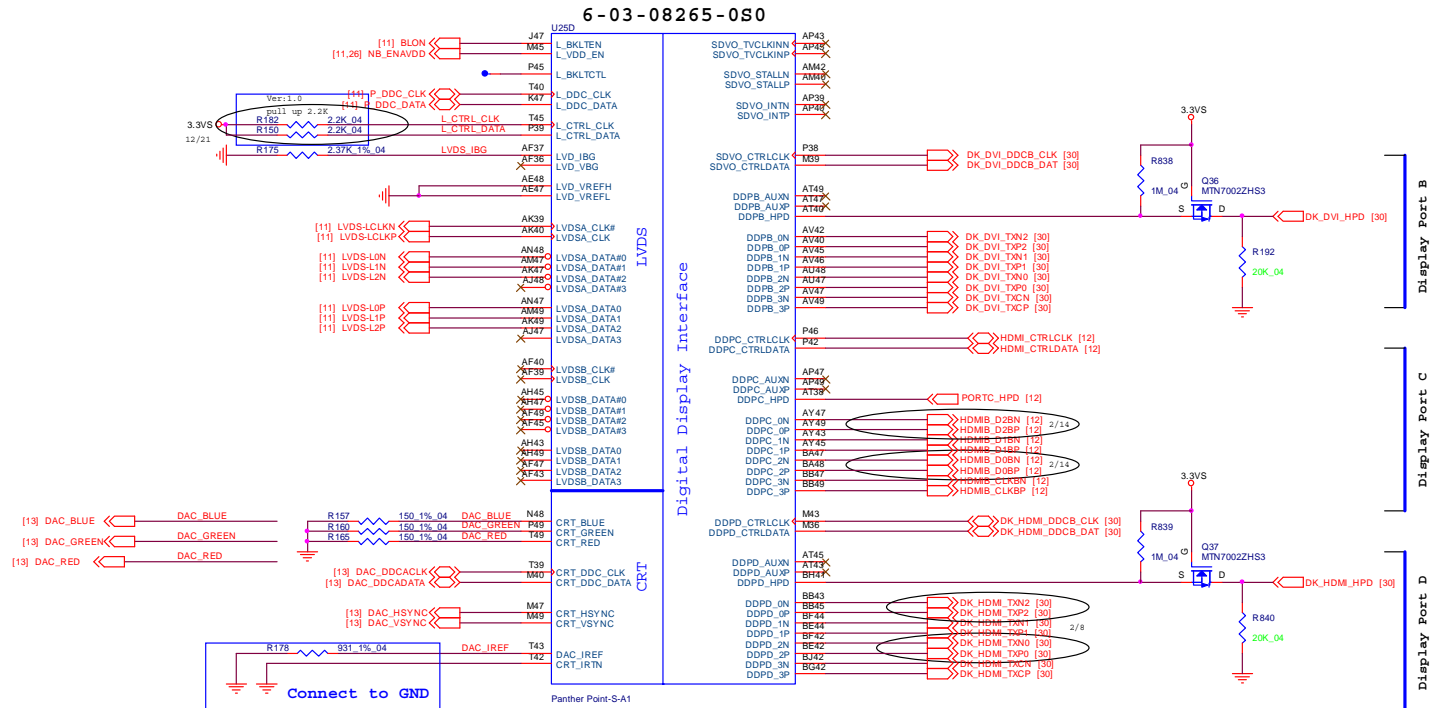

PCH 5/9

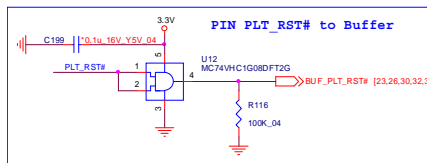
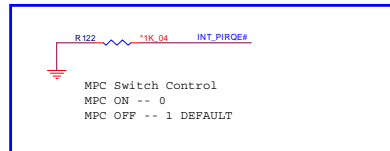
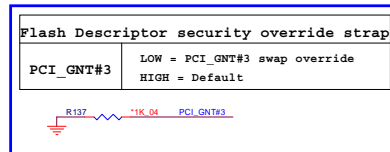
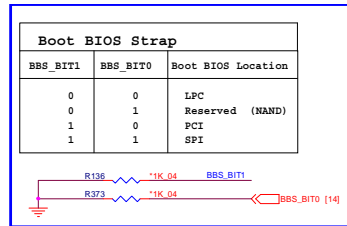

- [25] PCLK_TPM
- [15] CLK_PCI_FB
- [30] PCLK_C0M
- [28] PCLK_KBC

PantherPoint -M (PCI,USB,NVRAM)

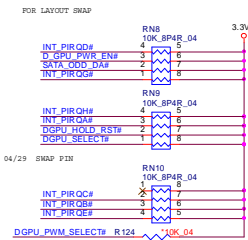
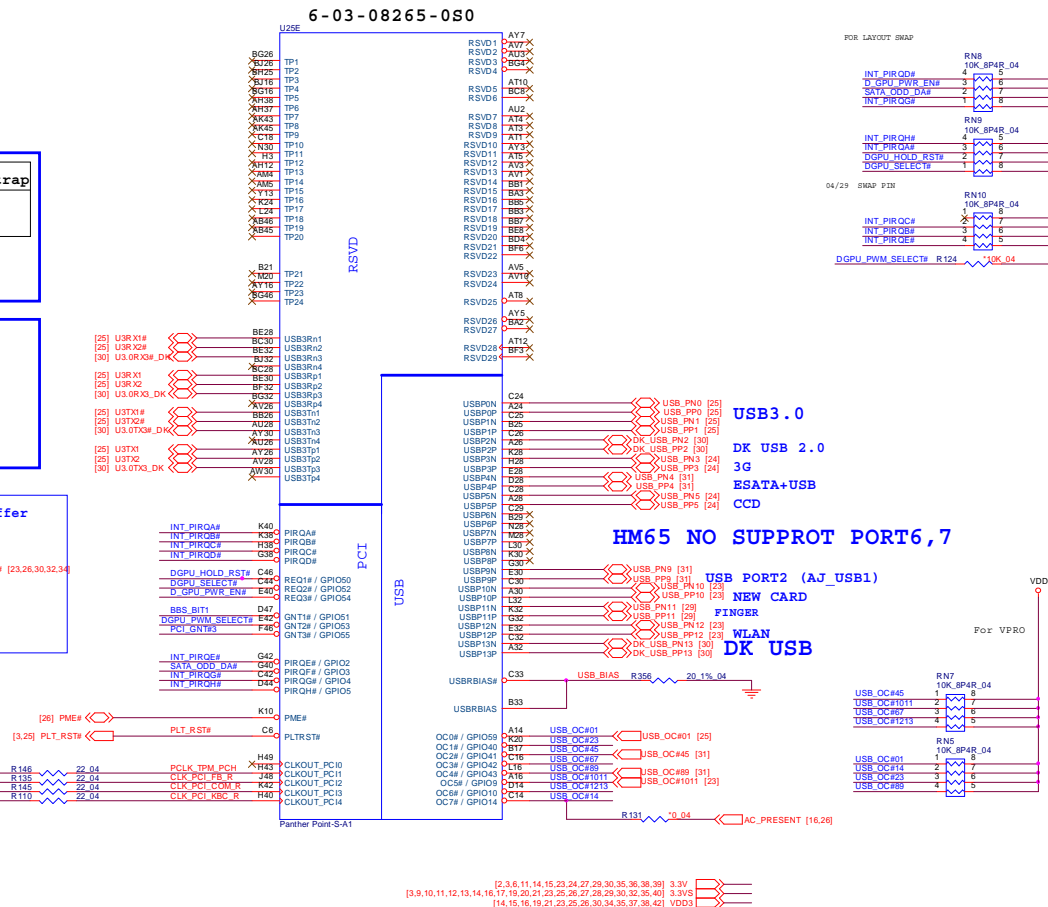

Sheet 18 of 47
PCH 5/9

B.Schematic Diagrams

PCH 7/9

PantherPoint -M (POWER)

6-03-08265-0S0

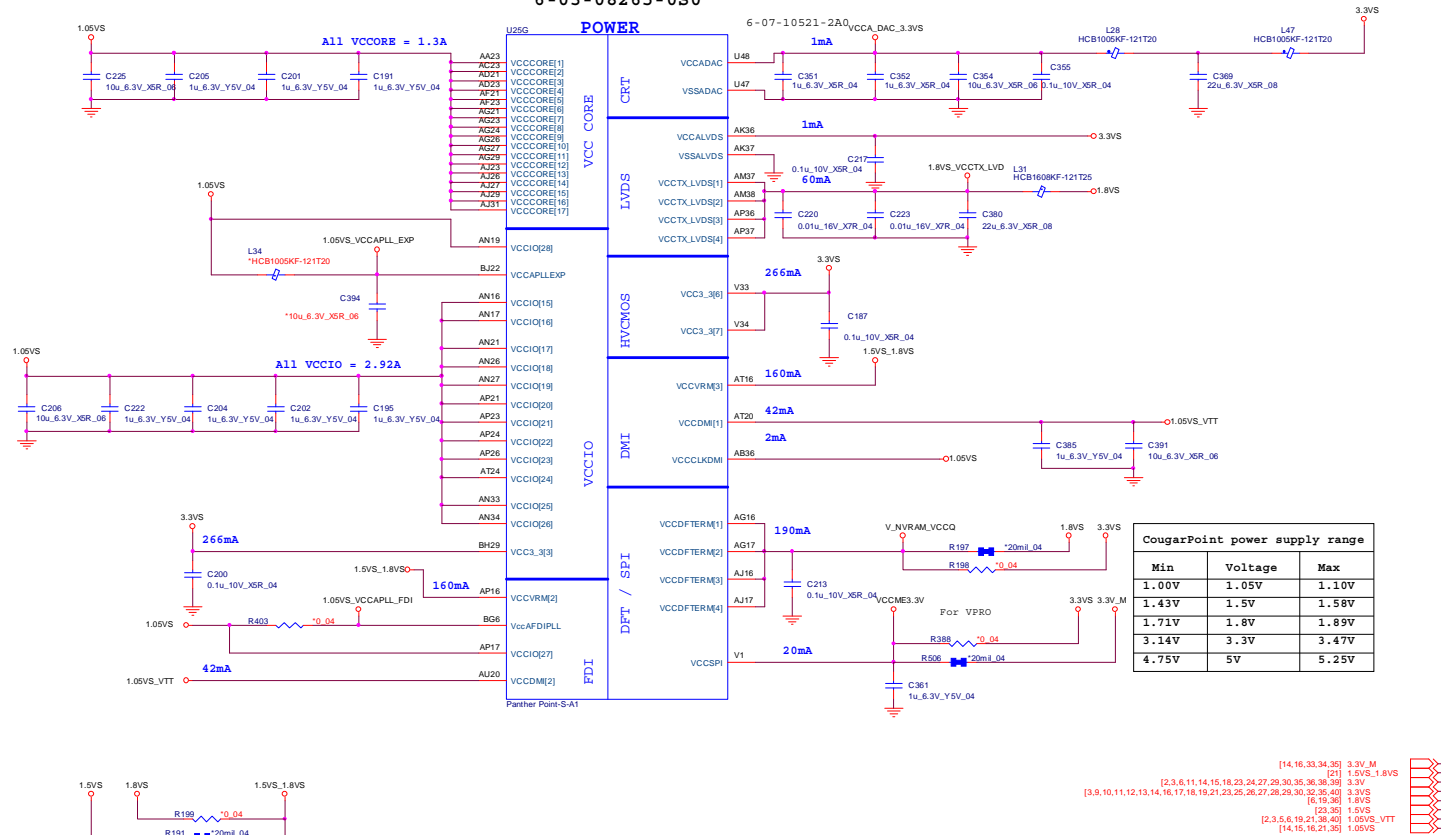

Sheet 20 of 47
PCH 7/9

B.Schematic Diagrams

NEW CARD, MINI PCIE

NEW CARD (Port 3)

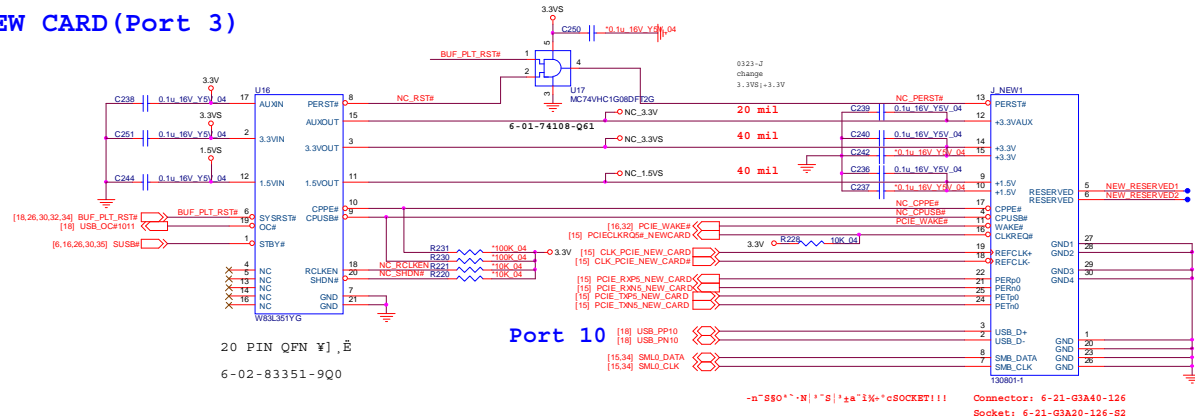

MINI CARD WLAN

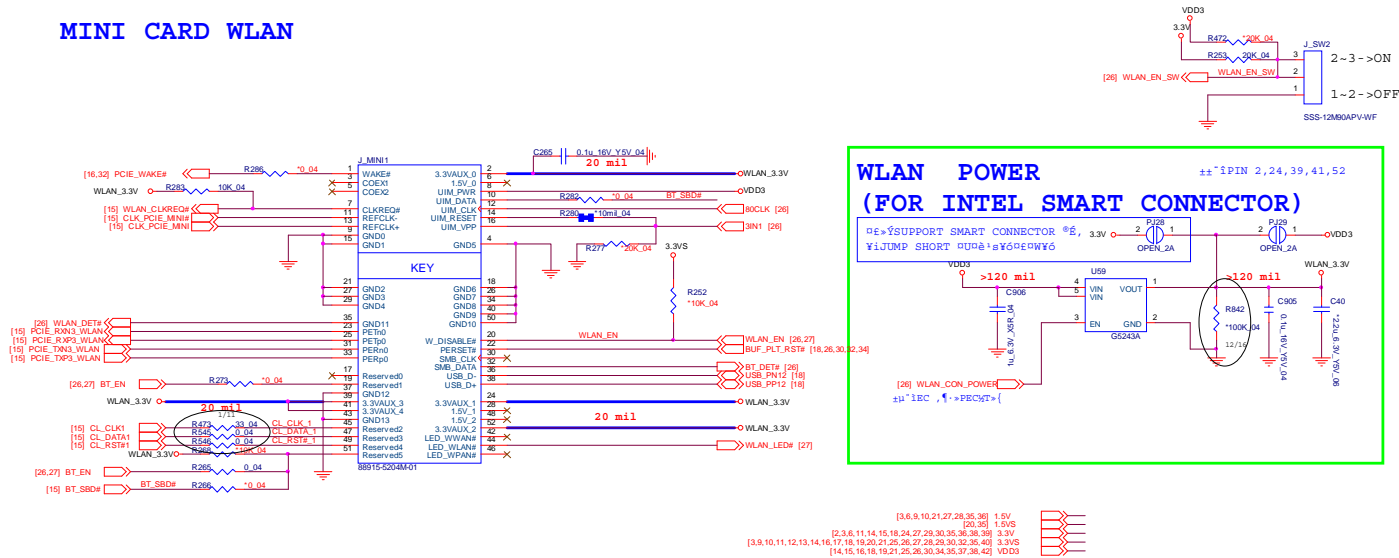

B.Schematic Diagrams

Sheet 23 of 47
NEW CARD, MINI PCIE

CCD, 3G

MINI CARD 3G (Port 6)

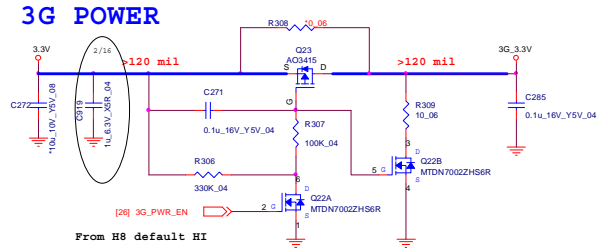
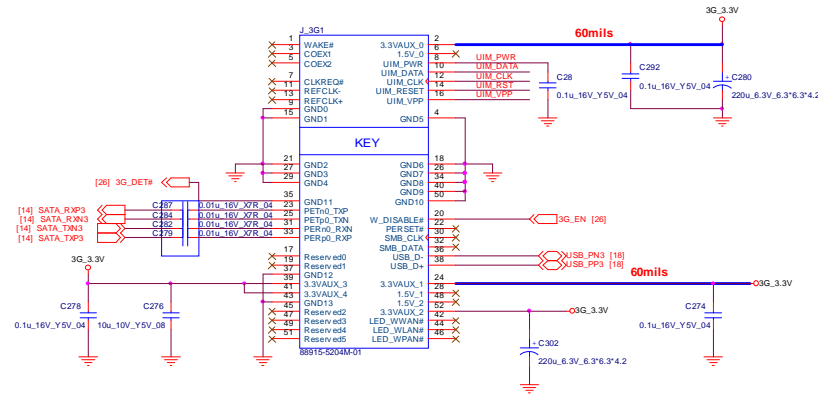

Sheet 24 of 47
CCD, 3G

B.Schematic Diagrams

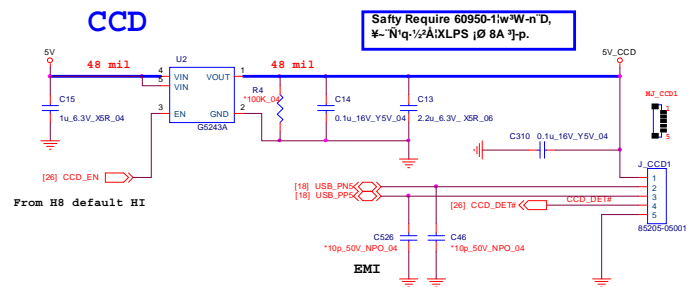

TPM, HDD, USB3.0 CONN + PWR

Sheet 25 of 47
TPM, HDD, USB3.0
CONN + PWR

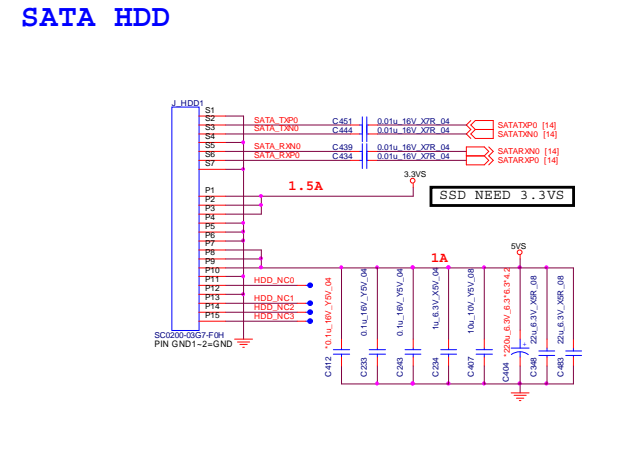
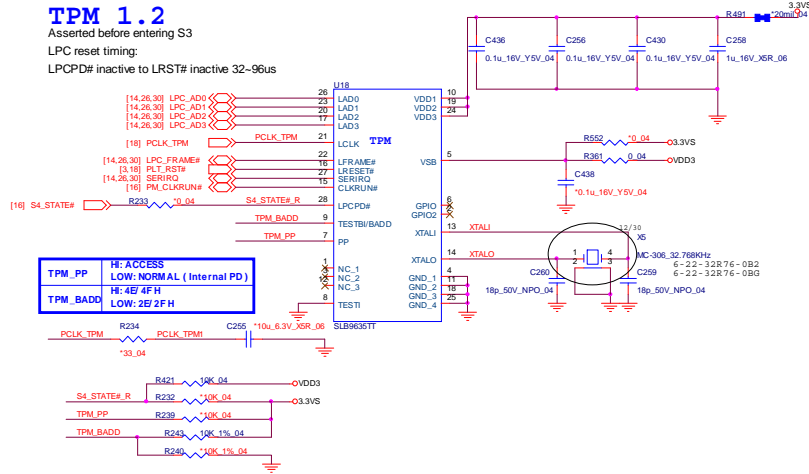

USB3.0 Conn + POWER

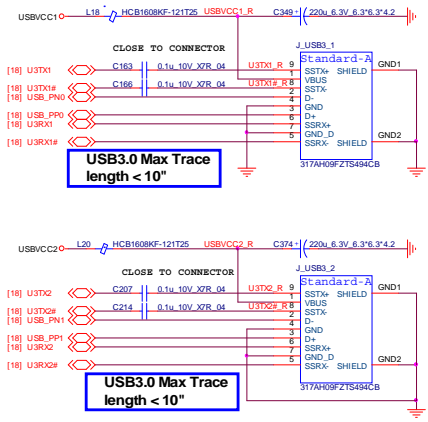
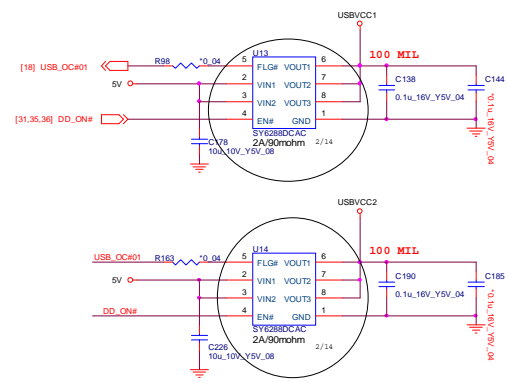

- 5V [24,31,35,36,38,39]
- VDD3 [14,15,16,18,19,21,23,26,30,34,35,37,38,42]
- VDS [12,13,21,28,29,35,40,41]
- 3.3VS [3,9,10,11,12,13,14,16,17,18,19,20,21,23,26,27,28,29,30,32,35,40]

KBC-ITE IT8518

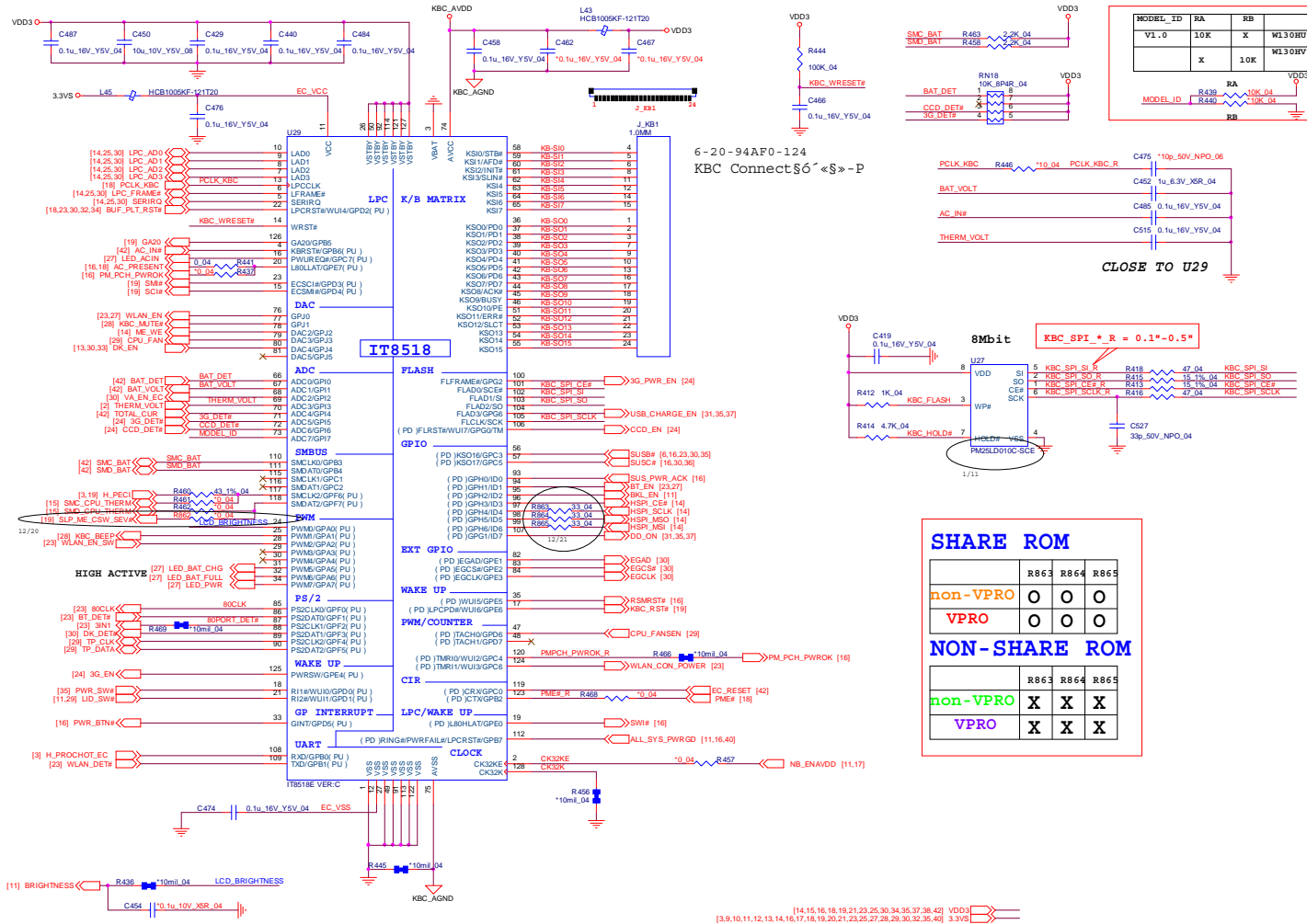

Sheet 26 of 47
KBC-ITE IT8518

B.Schematic Diagrams

LED, MDC

Sheet 27 of 47
LED, MDC

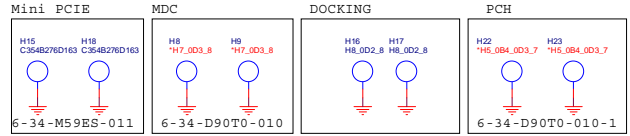
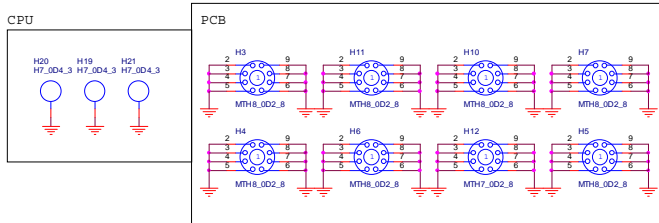
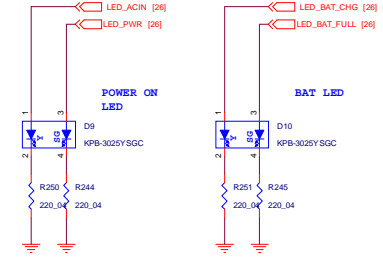
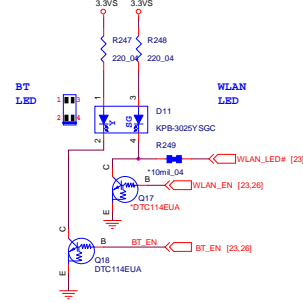
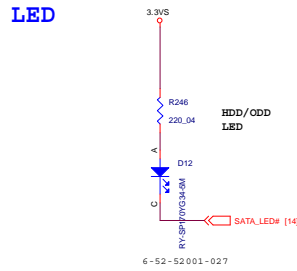
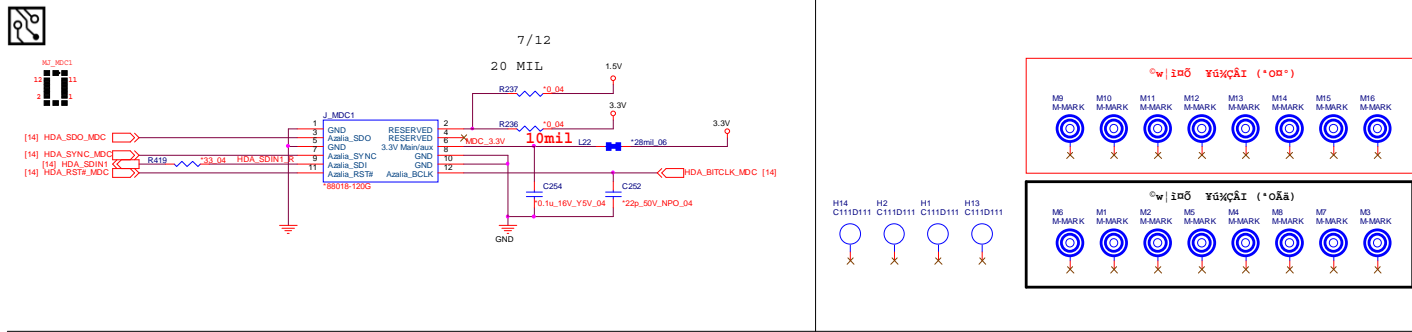

[3,6,9,10,21,28,35,38] 1.5V
[2,3,6,11,14,15,18,23,24,29,30,35,38,39] 3.3V
[3,8,10,11,12,13,14,16,17,18,19,20,21,23,25,26,28,29,30,35,40] 3.3VS

POWER CON, FAN, TP, CLICK CON

FAN CONTROL

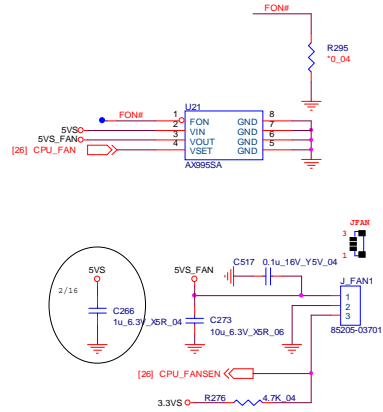

AX995B(SOT23-6) & APE8872
Dual-Layout

2nd Source PNAPE8874

Main Source APE8872 & 2nd
Source G990 Pin1 FON# not
necessary Pull down R1.

CLICK B'd CONN

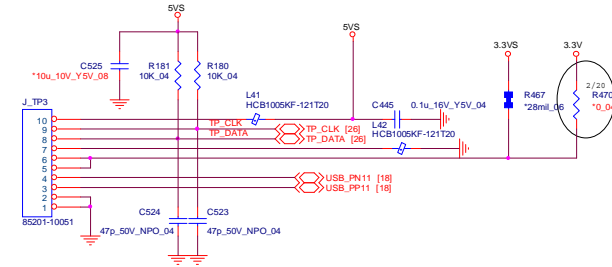

Sheet 29 of 47
POWER CON, FAN,
TP, CLICK CON

FOR POWER SWITCH BOARD

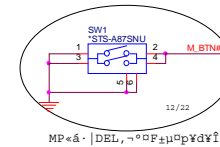
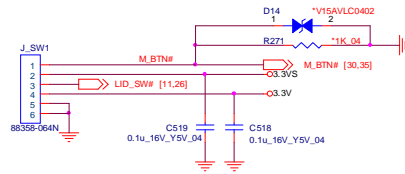

[2,3,6,11,14,15,18,23,24,27,30,35,36,38,39] 3.3V
[12,13,21,25,28,35,40,41] 5VS
[3,8,10,11,12,13,14,16,17,18,19,20,21,23,25,26,27,28,30,32,35,40] 3.3VS

AUDIO CONN, ESATA+USB+CHR

Sheet 31 of 47
AUDIO CONN,
ESATA+USB+CHR

Audio Conn. & USB Charger components

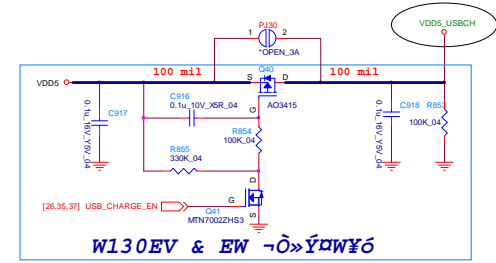
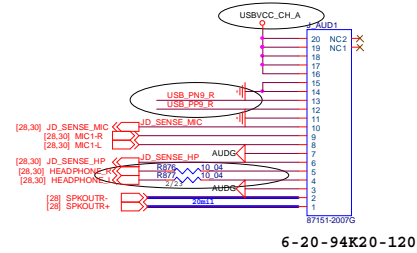

ESATA+USB & POW

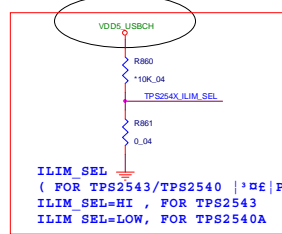
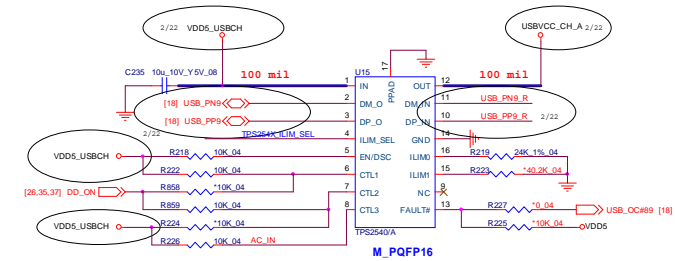
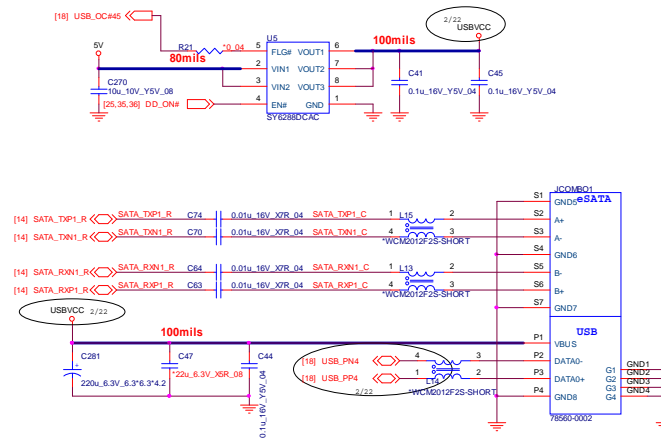

		CTL1	CTL2	CTL3
Mode 1	Power off & Discharge	0	0	0
Mode 2	Power off & Charge	0	1	1
Mode 3	Power off & Charge	1	0	1
Mode 4	Power on & Charge	1	1	1

[21,35,37,38] VDD5
[24,25,35,36,38,39] 5V
[2,3,6,11,14,15,18,23,24,27,29,30,35,36,38,39] GND

CARD READER JMC389

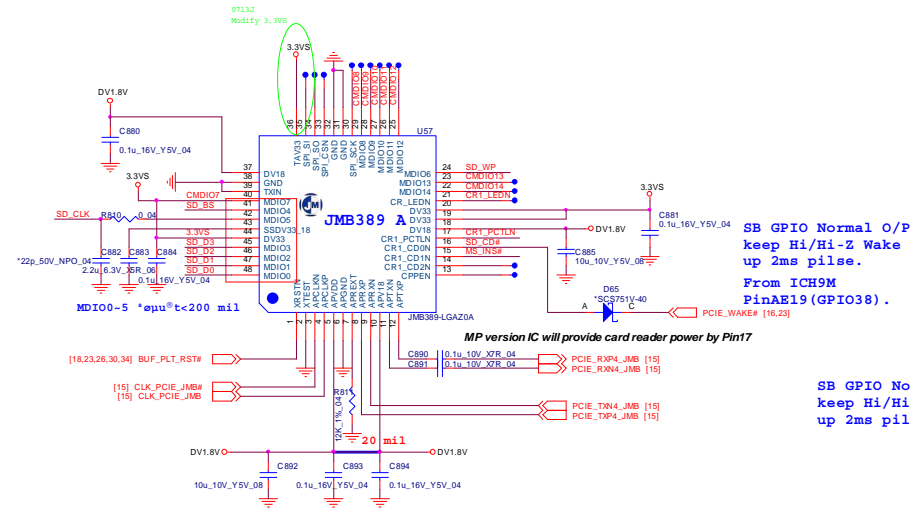

SB GPIO Normal O/P
keep Hi/Hi-Z Wake
up 2ms pilse.
From ICH9M
PinAE19 (GPIO38) .

SB GPIO Normal O/P
keep Hi/Hi-Z Wake
up 2ms pilse.

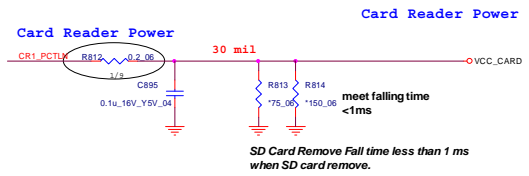
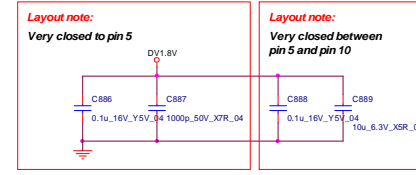
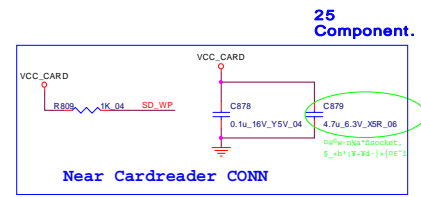

- Chip Note:**
1. All component must be closed to chip in this block.
 2. C70 place close to pin5 (Trace width/length: 10mil/<100mil) , C69 close to C70 (Trace width/length: 20mil/<100mil).
 3. C73 place close to pin10 (Trace width/length: 10mil/<100mil)
 4. Connect between Pin5 and Pin10 trace width/length: 20mil/<300mil
 5. APREXT trace width/length: 10mil/< 250mil
 6. C57 place close to pin18: 10mil/< 100mil for internal regulator usage

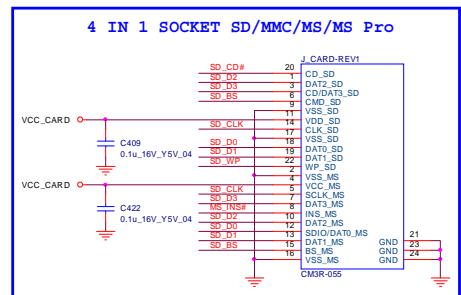

[14,15,16,18,19,21,23,25,26,30,34,35,37,38,42] VDD3
[3,9,10,11,12,13,14,16,17,18,19,20,21,23,25,26,27,28,29,30,35,40] 3.3V
[2,3,6,11,14,15,18,23,24,27,29,30,35,36,38,39] 3.3V

B.Schematic Diagrams

Sheet 32 of 47
CARD READER
JMC389

LAN (INTEL LAN82579)

Sheet 33 of 47
LAN (INTEL LAN82579)

GIGA LAN (INTEL LAN 82579)

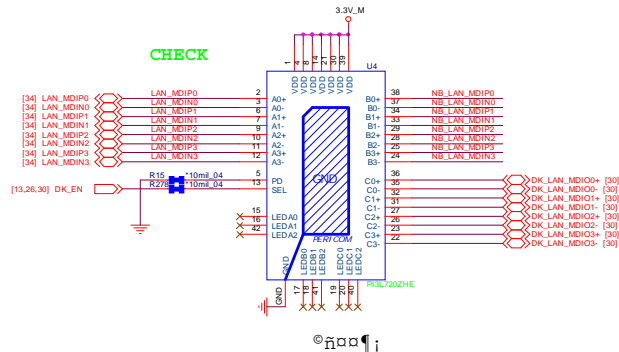
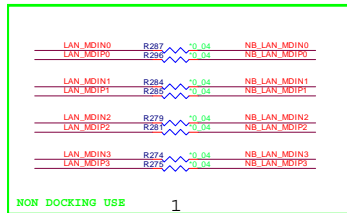
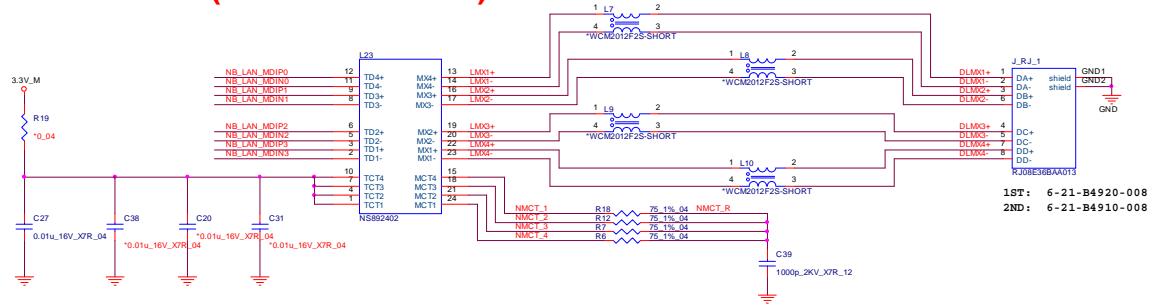

NB RJ45

DOCKING RJ45

PD	SEL	FUNCTION
L	L	Ax to Bx , LEDAx to LEDBx
L	H	Ax to Cx , LEDAx to LEDCx
H	X	Hi - Z

[14,16,20,34,35] 3.3V_M

INTEL LAN 82579LM

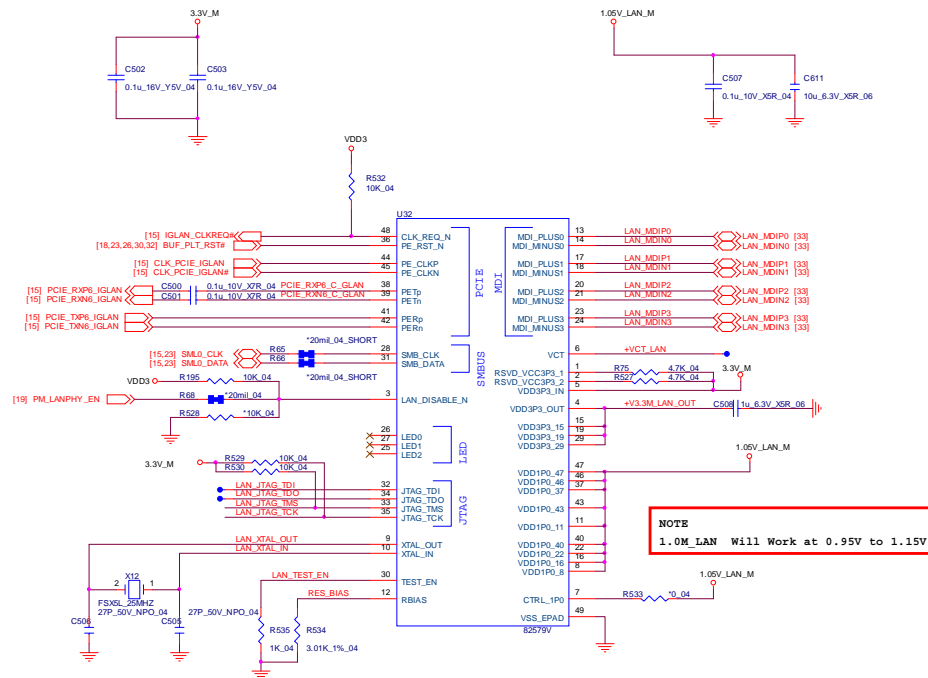

Sheet 34 of 47
INTEL LAN
82579LM

B.Schematic Diagrams

	U25	U32	U28	U41	U27
VPRO	QM67 6-03-08267-0S1	82579LM 6-03-82579-030-S6	MX25L3206E 6-04-25320-490	MX25L3206E 6-04-25320-490	PM25LD010C-SCE 6-04-25010-A91
non-VPRO	HM65 6-03-08265-0S1	82579V 6-03-82579-031-S	NI	NI	MX25L3206E 6-04-25320-490



Schematic Diagrams

5VS, 3VS, 1.5VS CPU

B.Schematic Diagrams

Sheet 35 of 47
5VS, 3VS, 1.5VS
CPU

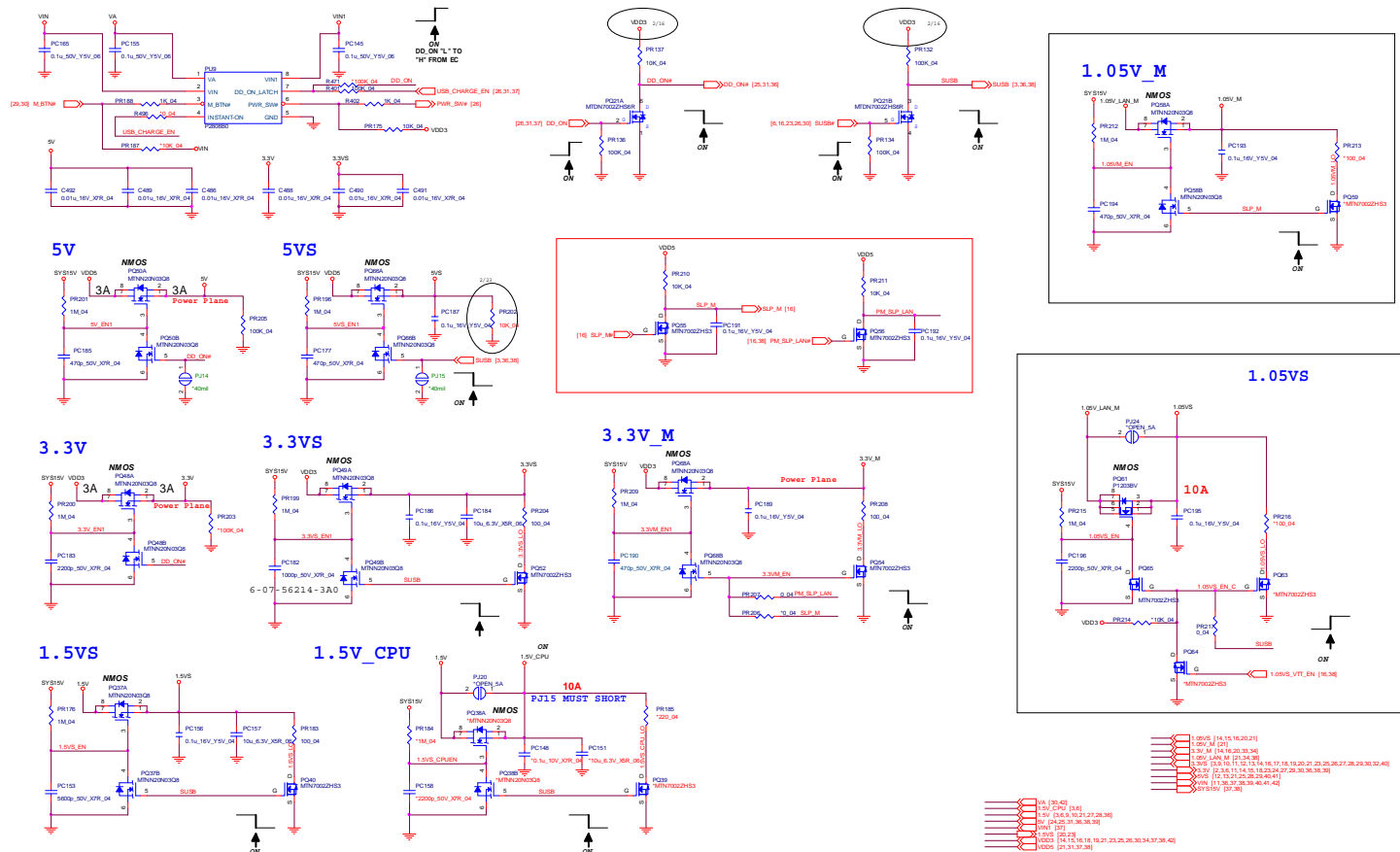

Power 1.5V/0.75V,1.8VS

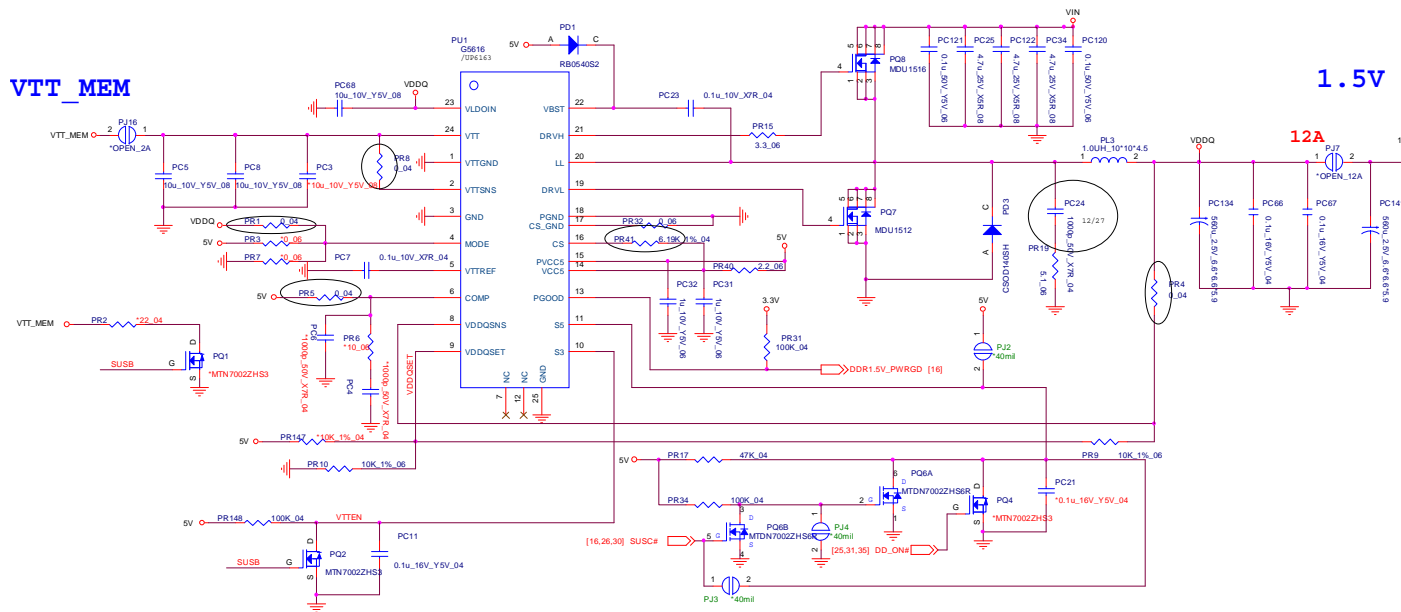

1.5V_CTRL1	1.5_CTRL0	Voltage
1	1	1.55V
1	0	1.60V
0	1	1.65V
0	0	1.70V

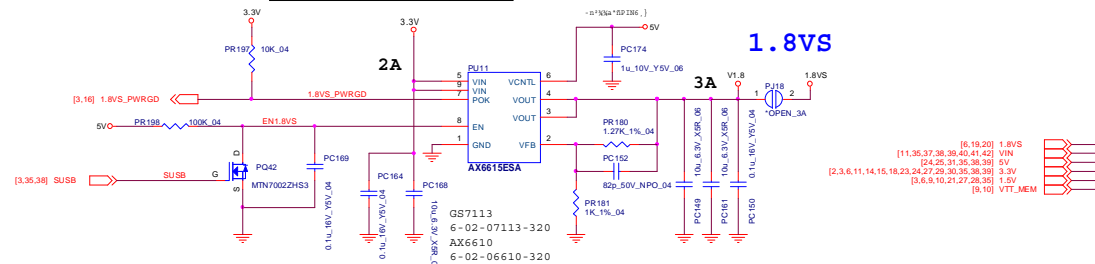

Sheet 36 of 47
Power 1.5V/
0.75V,1.8VS

B.Schematic Diagrams

POWER 0.85VS

Sheet 39 of 47
POWER 0.85VS

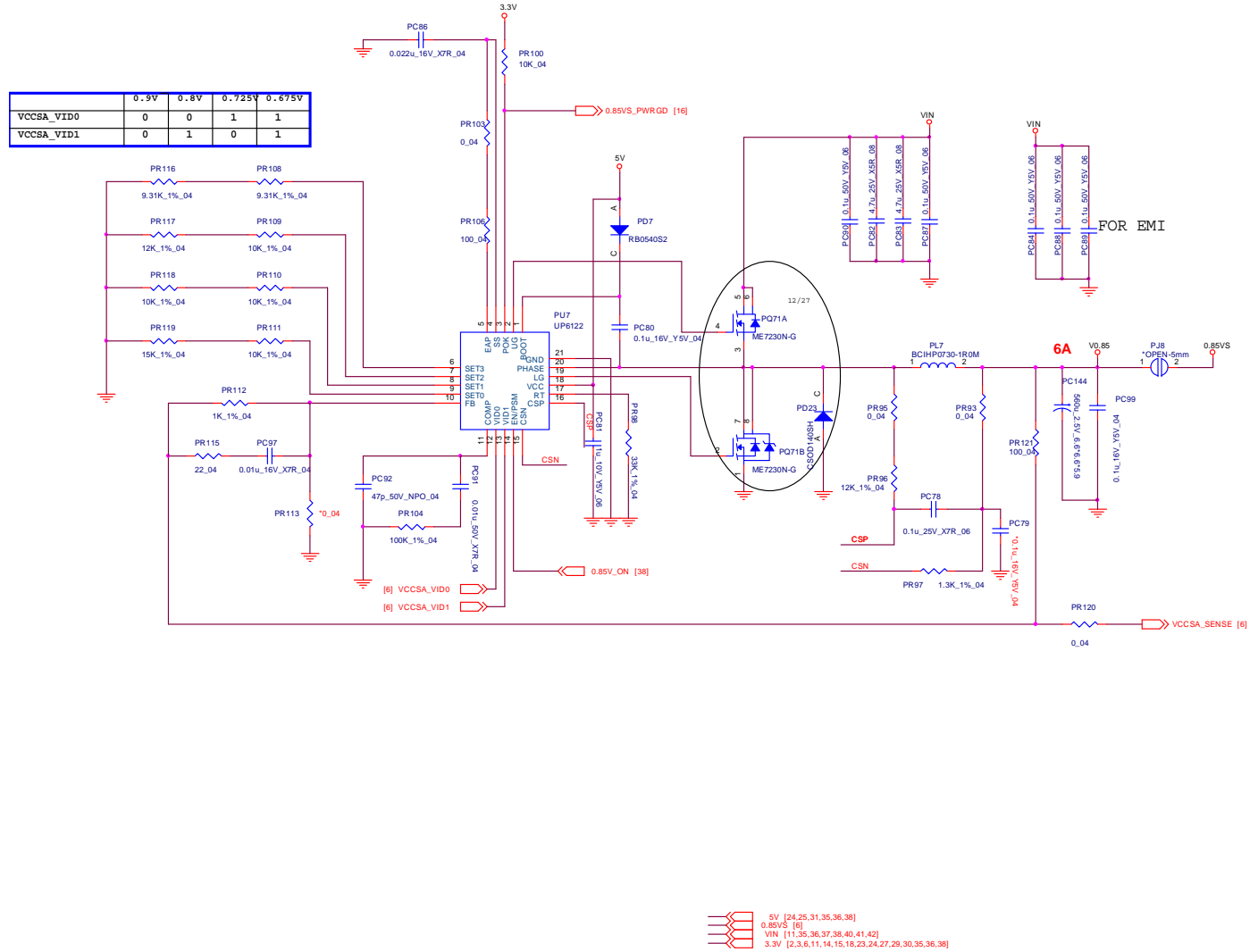

Power V-CORE 2

Sheet 41 of 47
Power V-CORE 2

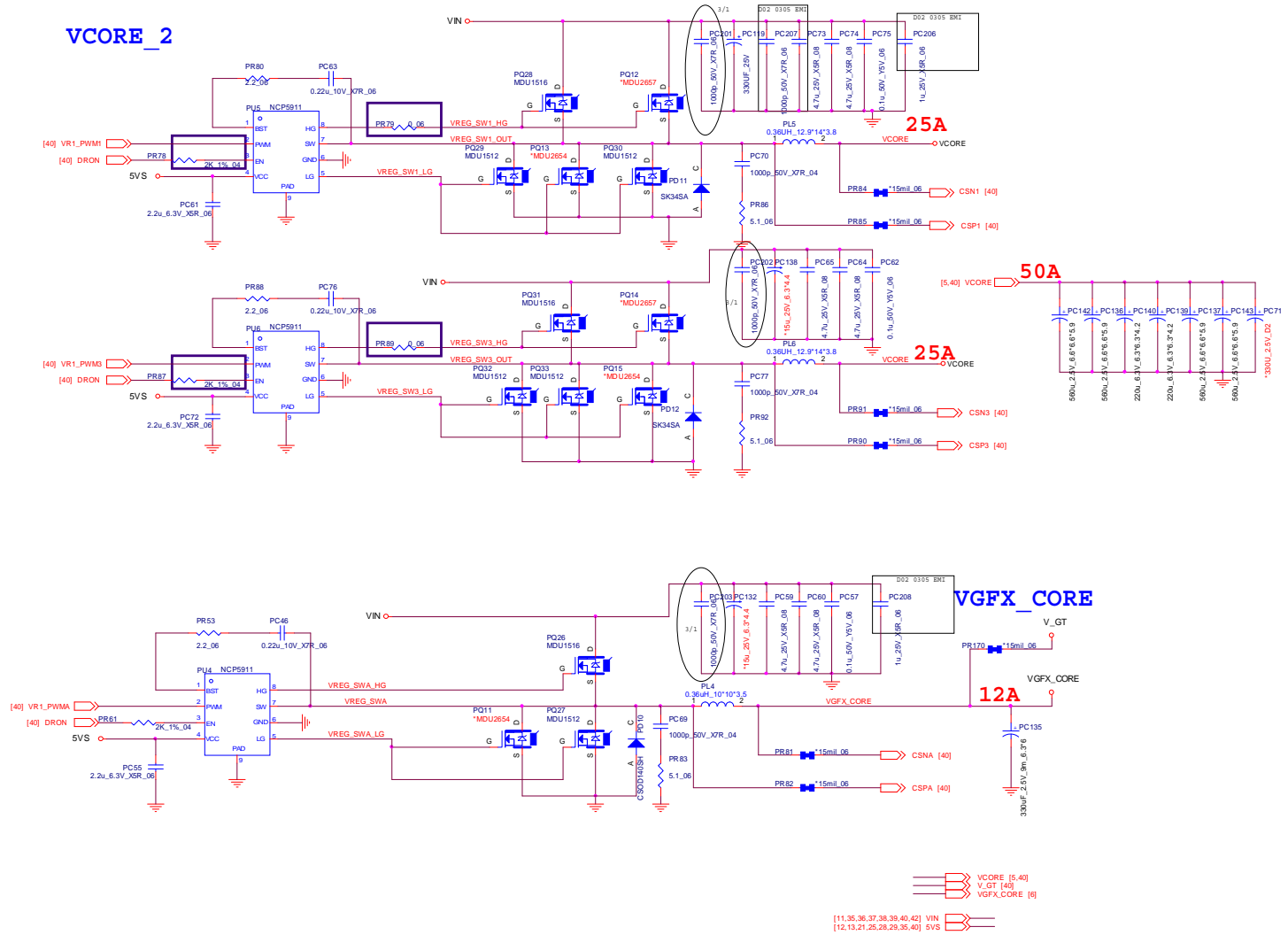

CHARGE, DC IN

2PCS MOSFET,180W-220W : 3PCS , 300W: 4PCS , 360W: 5PCS

CHARGER

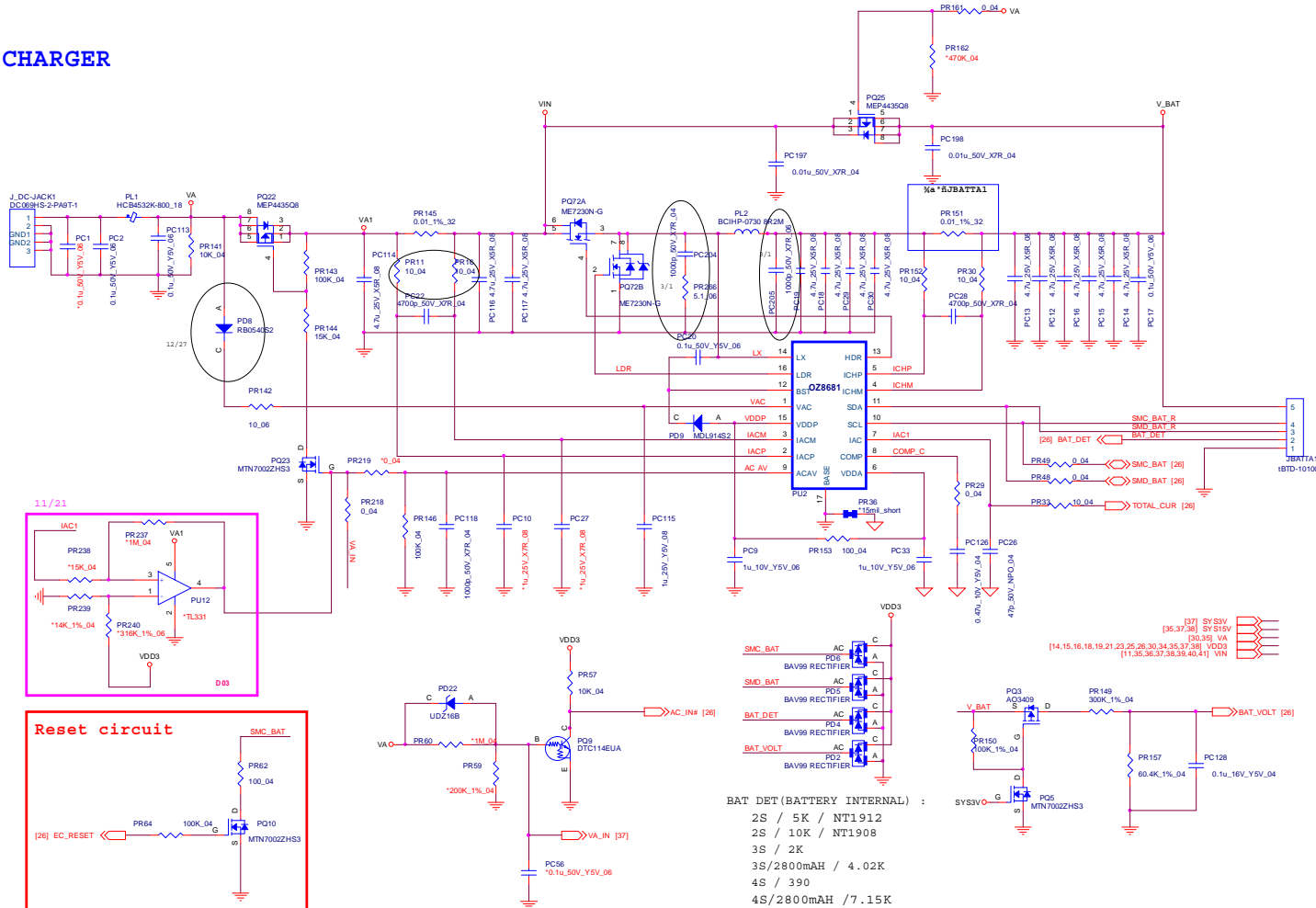

Sheet 42 of 47
CHARGE, DC IN

B.Schematic Diagrams

Schematic Diagrams

CLICK BOARD / FG

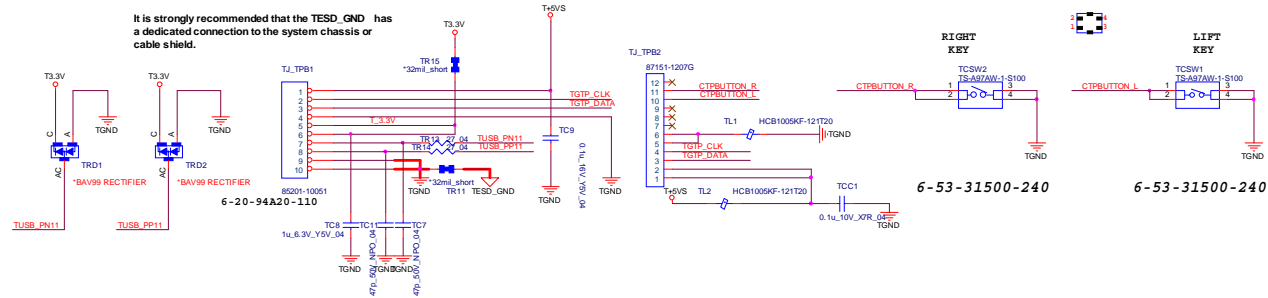

Sheet 43 of 47
CLICK BOARD/ FG

B.Schematic Diagrams

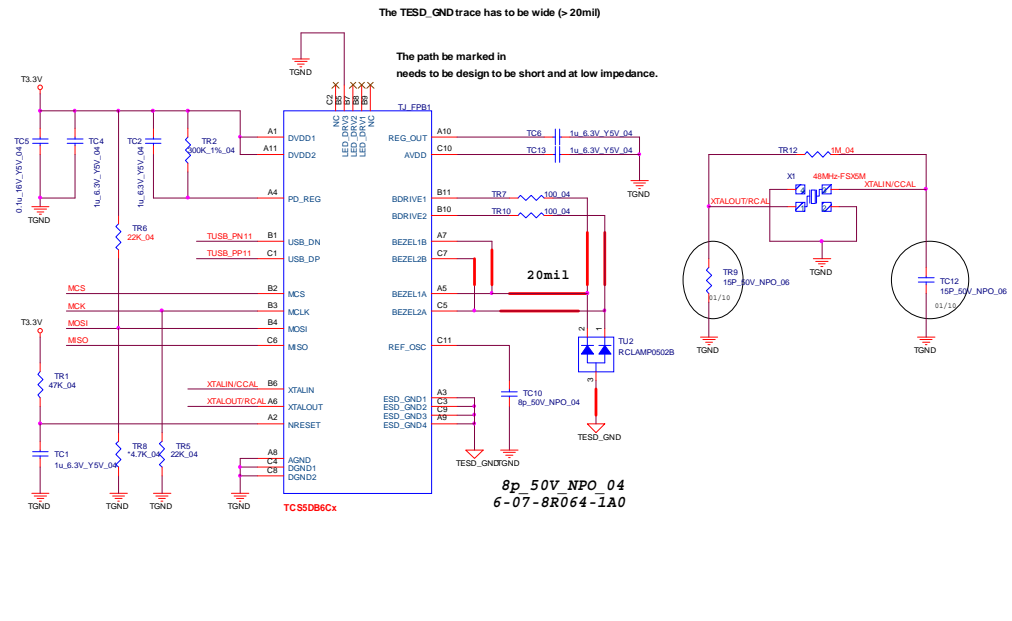

AUDIO BOARD/ USB, HP, MIC

USB PORT

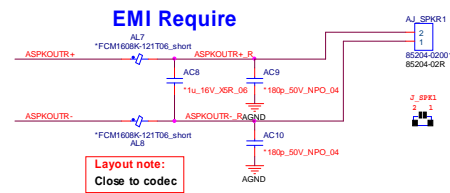
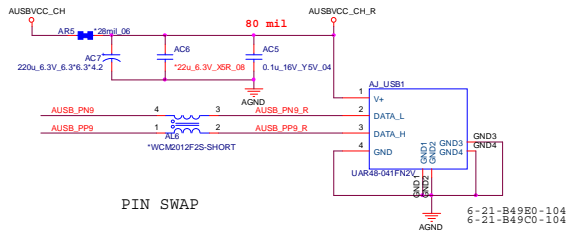

TO M/B

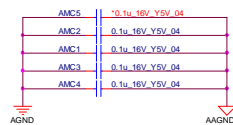
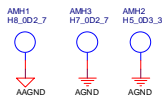
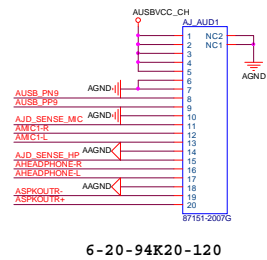

AUDIO JACK

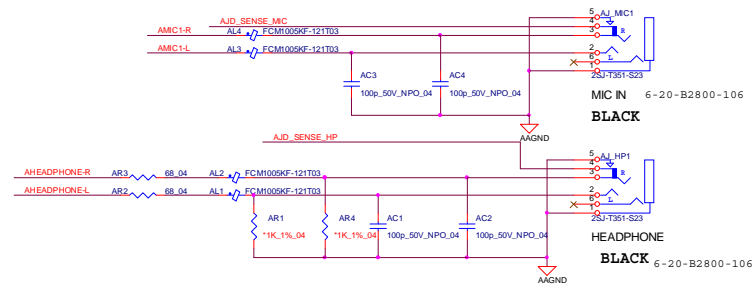

Sheet 44 of 47
AUDIO BOARD/
USB, HP, MIC

POWER SWITCH

Sheet 45 of 47
POWER SWITCH

POWER SW & LED & HOT KEY

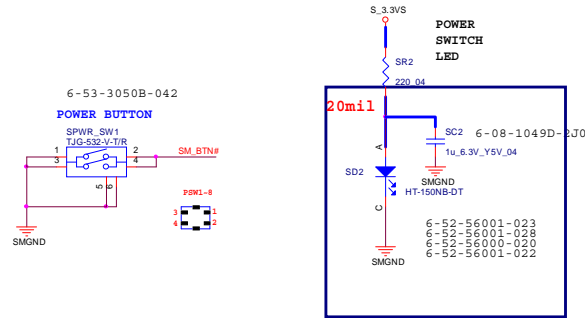

LID SWITCH IC

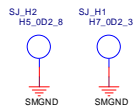
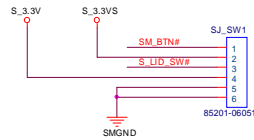
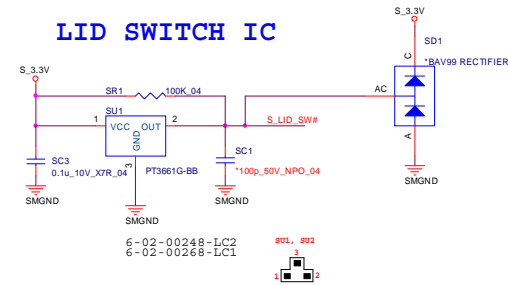

DEBUG BOARD

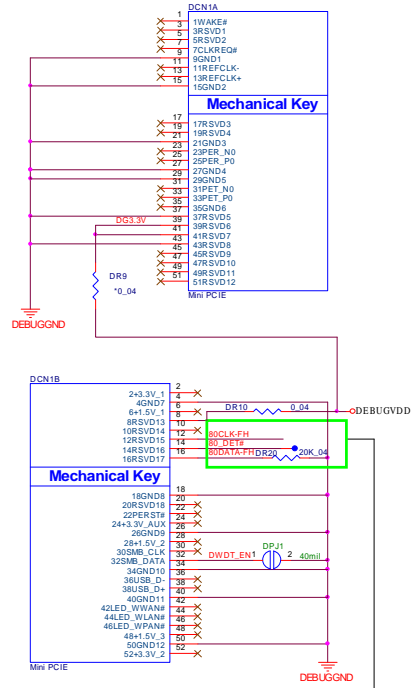

PIN51 & PIN8 Swap Future for Huron River Platform Debug Card Used.
PIN46 & PIN12 Swap Future for Huron River Platform Debug Card Used.
PIN17 & PIN14 Swap Future for Huron River Platform Debug Card Used.
PIN19 & PIN16 Swap Future for Huron River Platform Debug Card Used.



4 bits 80 Port Debug Card

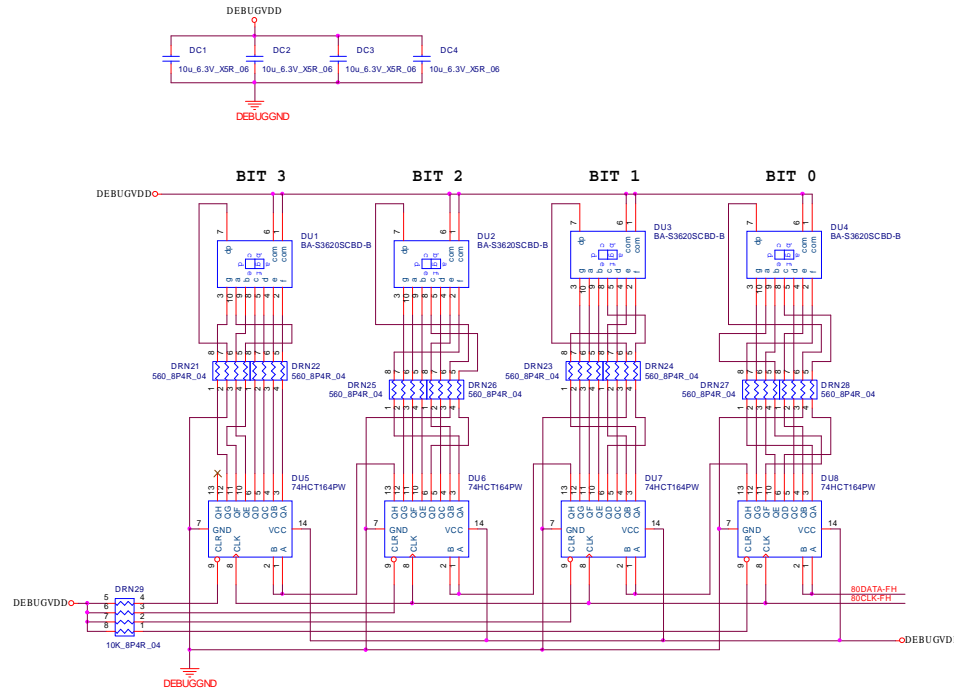

Near 74164 pin-14

Sheet 46 of 47
DEBUG BOARD

Power Sequence

Sheet 47 of 47
Power Sequence

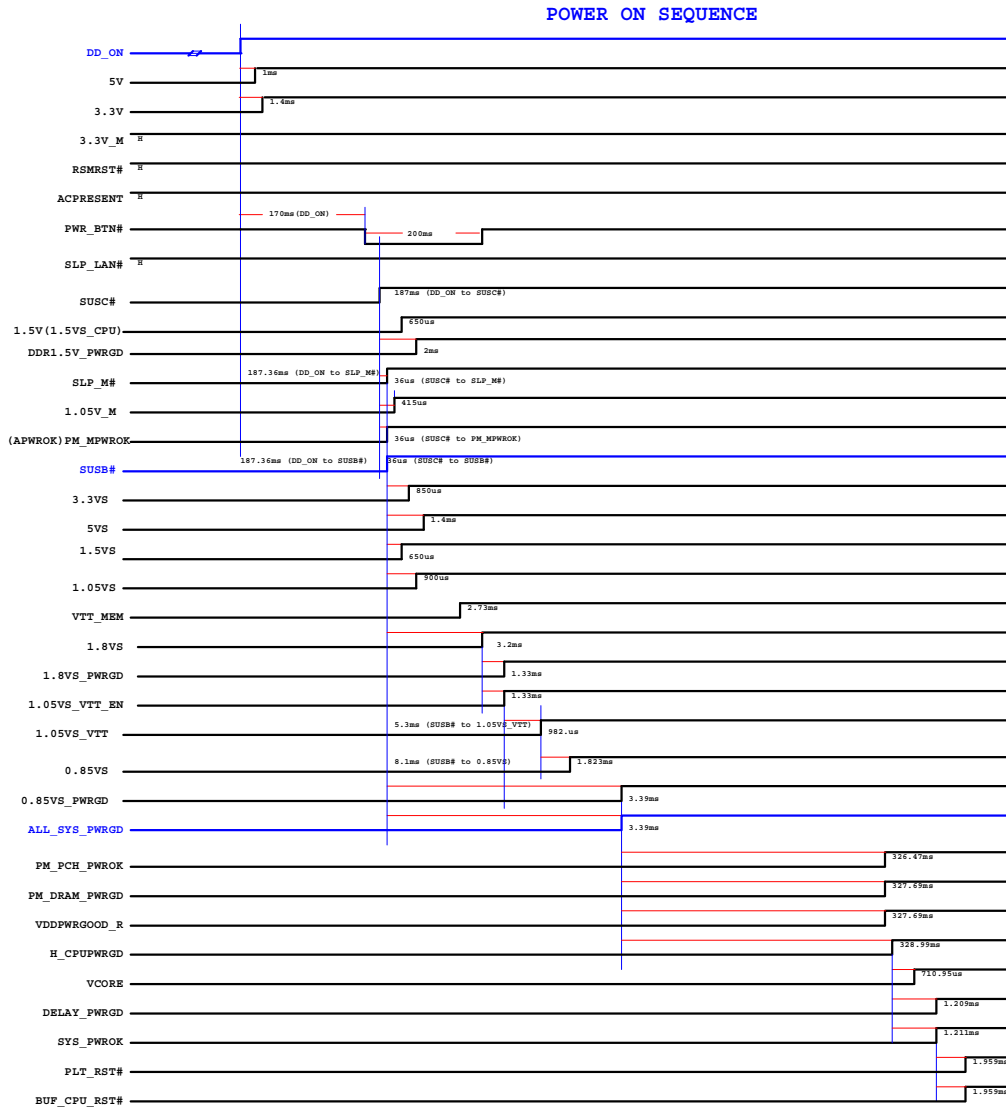

Appendix C: Updating the FLASH ROM BIOS

To update the FLASH ROM BIOS you must:

- Download the BIOS update from the web site.
- Unzip the files onto a bootable CD/DVD/USB Flash Drive.
- Reboot your computer from an external CD/DVD/USB Flash Drive.
- Use the flash tools to update the flash BIOS using the commands indicated below.
- Restart the computer booting from the HDD and press **F2** at startup enter the BIOS.
- Load setup defaults from the BIOS and save the default settings and exit the BIOS to restart the computer.
- After rebooting the computer you may restart the computer again and make any required changes to the default BIOS settings.

Download the BIOS

1. Go to www.clevo.com.tw and point to **E-Services** and click **E-Channel**.
2. Use your user ID and password to access the appropriate download area (BIOS), and download the latest BIOS files (the BIOS file will be contained in a batch file that may be run directly once unzipped) for your computer model (see sidebar for important information on BIOS versions).

Unzip the downloaded files to a bootable CD/DVD/ or USB Flash drive

1. Insert a bootable CD/DVD/USB flash drive into the CD/DVD drive/USB port of the computer containing the downloaded files.
2. Use a tool such as Winzip or Winrar to unzip all the BIOS files and refresh tools to your bootable CD/DVD/USB flash drive (you may need to create a bootable CD/DVD with the files using a 3rd party software).

Set the computer to boot from the external drive

1. With the bootable CD/DVD/USB flash drive containing the BIOS files in your CD/DVD drive/USB port, restart the computer and press **F2** (in most cases) to enter the BIOS.
2. Use the arrow keys to highlight the **Boot** menu.
3. Use the “+” and “-” keys to move boot devices up and down the priority order.
4. Make sure that the CD/DVD drive/USB flash drive is set first in the boot priority of the BIOS.
5. Press **F10** to save any changes you have made and exit the BIOS to restart the computer.



BIOS Version

Make sure you download the latest correct version of the BIOS appropriate for the computer model you are working on.

You should only download BIOS versions that are **V1.01.XX or higher** as appropriate for your computer model.

Note that BIOS versions are not backward compatible and therefore **you may not downgrade your BIOS to an older version** after upgrading to a later version (e.g if you upgrade a BIOS to ver 1.01.05, you **MAY NOT** then go back and flash the BIOS to ver 1.01.04).

BIOS Update

Use the flash tools to update the BIOS

1. Make sure you are not loading any memory management programs such as HIMEM by holding the **F8** key as you see the message “**Starting MS-DOS**”. You will then be prompted to give “**Y**” or “**N**” responses to the programs being loaded by DOS. Choose “**N**” for any memory management programs.
2. You should now be at the DOS prompt e.g: DISK C:\> (C is the designated drive letter for the CD/DVD drive/USB flash drive).
3. **Type the following command** at the DOS prompt:

C:\> Flash.bat

4. The utility will then proceed to flash the BIOS.
5. You should then be prompted to press any key to restart the system or turn the power off, and then on again but make sure you remove the CD/DVD/USB flash drive from the CD/DVD drive/USB port before the computer restarts.

Restart the computer (booting from the HDD)

1. With the CD/DVD/USB flash drive removed from the CD/DVD drive/USB port the computer should restart from the HDD.
2. Press **F2** as the computer restarts to enter the BIOS.
3. Use the arrow keys to highlight the **Exit** menu.
4. Select **Load Setup Defaults** (or press **F9**) and select “**Yes**” to confirm the selection.
5. Press **F10** to save any changes you have made and exit the BIOS to restart the computer.

Your computer is now running normally with the updated BIOS

You may now enter the BIOS and make any changes you require to the default settings.

www.s-manuals.com