

# SERVICE MANUAL

**W250HU/W250HUQ/W251HUQ-C/W252HUM/W252HUM-C  
W255HU/W255HU-C/W255HUM/W255HUM-C/W258HUQ-C**

*notebook*





## Notebook Computer

W250HU/W250HUQ/W251HUQ-C/W252HUM/W252HUM-C/  
W255HU/W255HU-C/W255HUM/W255HUM-C/W258HUQ-C

## Service Manual

### Notice

The company reserves the right to revise this publication or to change its contents without notice. Information contained herein is for reference only and does not constitute a commitment on the part of the manufacturer or any subsequent vendor. They assume no responsibility or liability for any errors or inaccuracies that may appear in this publication nor are they in anyway responsible for any loss or damage resulting from the use (or misuse) of this publication.

This publication and any accompanying software may not, in whole or in part, be reproduced, translated, transmitted or reduced to any machine readable form without prior consent from the vendor, manufacturer or creators of this publication, except for copies kept by the user for backup purposes.

Brand and product names mentioned in this publication may or may not be copyrights and/or registered trademarks of their respective companies. They are mentioned for identification purposes only and are not intended as an endorsement of that product or its manufacturer.

Version 2.0  
March 2011

### Trademarks

**Intel and Intel Core** are trademarks of Intel Corporation.

**Windows<sup>®</sup>** is a registered trademark of Microsoft Corporation.

Other brand and product names are trademarks and /or registered trademarks of their respective companies.

## About this Manual

This manual is intended for service personnel who have completed sufficient training to undertake the maintenance and inspection of personal computers.

It is organized to allow you to look up basic information for servicing and/or upgrading components of the *W250HU/W250HUQ/W251HUQ-C/W252HUM/W252HUM-C/W255HU/W255HU-C/W255HUM/W255HUM-C/W258HUQ-C* series notebook PC.

The following information is included:

Chapter 1, Introduction, provides general information about the location of system elements and their specifications.

Chapter 2, Disassembly, provides step-by-step instructions for disassembling parts and subsystems and how to upgrade elements of the system.

Appendix A, Part Lists

Appendix B, Schematic Diagrams

Appendix C, Updating the FLASH ROM BIOS

## IMPORTANT SAFETY INSTRUCTIONS

Follow basic safety precautions, including those listed below, to reduce the risk of fire, electric shock and injury to persons when using any electrical equipment:

1. Do not use this product near water, for example near a bath tub, wash bowl, kitchen sink or laundry tub, in a wet basement or near a swimming pool.
2. Avoid using a telephone (other than a cordless type) during an electrical storm. There may be a remote risk of electrical shock from lightning.
3. Do not use the telephone to report a gas leak in the vicinity of the leak.
4. Use only the power cord and batteries indicated in this manual. Do not dispose of batteries in a fire. They may explode. Check with local codes for possible special disposal instructions.
5. This product is intended to be supplied by a Listed Power Unit with an AC Input of 100 - 240V, 50 - 60Hz, DC Output of 19V, 3.42A or 18.5V, 3.5A (**65W**) minimum AC/DC Adapter.

## CAUTION

**This Computer's Optical Device is a Laser Class 1 Product**

### FCC Statement

This device complies with Part 15 of the FCC Rules. Operation is subject to the following two conditions:

This device may not cause harmful interference.

This device must accept any interference received, including interference that may cause undesired operation.

## Instructions for Care and Operation

The notebook computer is quite rugged, but it can be damaged. To prevent this, follow these suggestions:

1. **Don't drop it, or expose it to shock.** If the computer falls, the case and the components could be damaged.



2. **Keep it dry, and don't overheat it.** Keep the computer and power supply away from any kind of heating element. This is an electrical appliance. If water or any other liquid gets into it, the computer could be badly damaged.

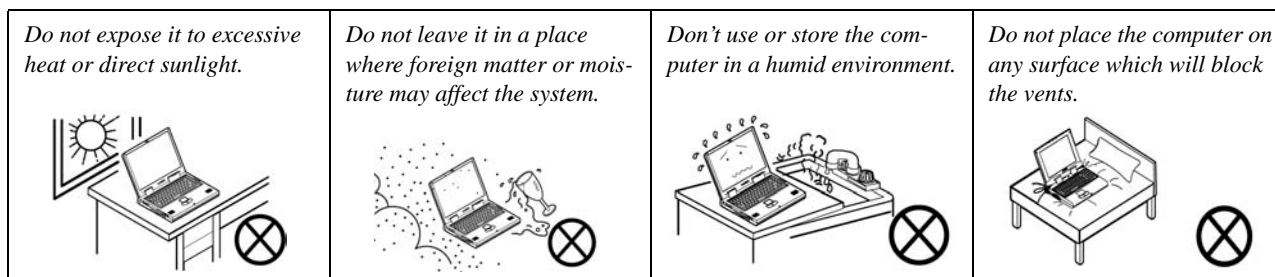

3. **Follow the proper working procedures for the computer.** Shut the computer down properly and don't forget to save your work. Remember to periodically save your data as data may be lost if the battery is depleted.

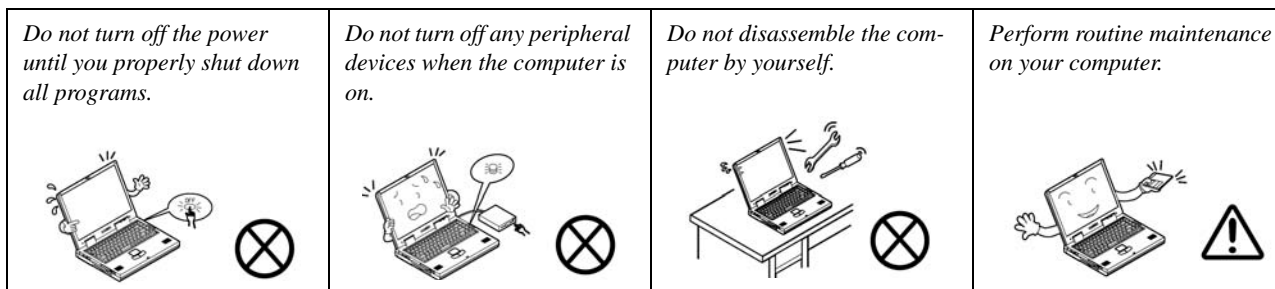

4. **Avoid interference.** Keep the computer away from high capacity transformers, electric motors, and other strong magnetic fields. These can hinder proper performance and damage your data.
5. **Take care when using peripheral devices.**

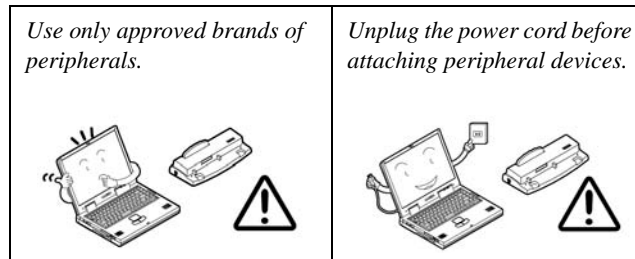

## Power Safety

The computer has specific power requirements:

- Only use a power adapter approved for use with this computer.
- Your AC adapter may be designed for international travel but it still requires a steady, uninterrupted power supply. If you are unsure of your local power specifications, consult your service representative or local power company.
- The power adapter may have either a 2-prong or a 3-prong grounded plug. The third prong is an important safety feature; do not defeat its purpose. If you do not have access to a compatible outlet, have a qualified electrician install one.
- When you want to unplug the power cord, be sure to disconnect it by the plug head, not by its wire.
- Make sure the socket and any extension cord(s) you use can support the total current load of all the connected devices.
- Before cleaning the computer, make sure it is disconnected from any external power supplies.

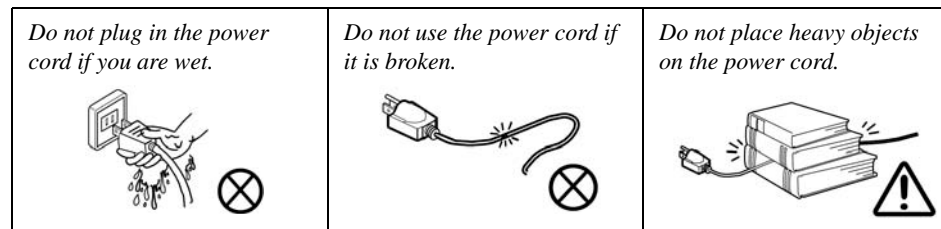

### Power Safety Warning

Before you undertake any upgrade procedures, make sure that you have turned off the power, and disconnected all peripherals and cables (including telephone lines). It is advisable to also remove your battery in order to prevent accidentally turning the machine on.



## Battery Precautions

- Only use batteries designed for this computer. The wrong battery type may explode, leak or damage the computer.
- Do not continue to use a battery that has been dropped, or that appears damaged (e.g. bent or twisted) in any way. Even if the computer continues to work with a damaged battery in place, it may cause circuit damage, which may possibly result in fire.
- Recharge the batteries using the notebook's system. Incorrect recharging may make the battery explode.
- Do not try to repair a battery pack. Refer any battery pack repair or replacement to your service representative or qualified service personnel.
- Keep children away from, and promptly dispose of a damaged battery. Always dispose of batteries carefully. Batteries may explode or leak if exposed to fire, or improperly handled or discarded.
- Keep the battery away from metal appliances.
- Affix tape to the battery contacts before disposing of the battery.
- Do not touch the battery contacts with your hands or metal objects.

## Battery Guidelines

The following can also apply to any backup batteries you may have.

- If you do not use the battery for an extended period, then remove the battery from the computer for storage.
- Before removing the battery for storage charge it to 60% - 70%.
- Check stored batteries at least every 3 months and charge them to 60% - 70%.



### Battery Disposal

The product that you have purchased contains a rechargeable battery. The battery is recyclable. At the end of its useful life, under various state and local laws, it may be illegal to dispose of this battery into the municipal waste stream. Check with your local solid waste officials for details in your area for recycling options or proper disposal.

### Caution

Danger of explosion if battery is incorrectly replaced. Replace only with the same or equivalent type recommended by the manufacturer. Discard used battery according to the manufacturer's instructions.

### Battery Level

Click the battery icon  in the taskbar to see the current battery level and charge status. A battery that drops below a level of 10% will not allow the computer to boot up. Make sure that any battery that drops below 10% is recharged within one week.

## Related Documents

You may also need to consult the following manual for additional information:

### User's Manual on CD/DVD

This describes the notebook PC's features and the procedures for operating the computer and its ROM-based setup program. It also describes the installation and operation of the utility programs provided with the notebook PC.

## System Startup

1. Remove all packing materials.
2. Place the computer on a stable surface.
3. Insert the battery and make sure it is locked in position.
4. Securely attach any peripherals you want to use with the computer (e.g. keyboard and mouse) to their ports.
5. Attach the AC/DC adapter to the DC-In jack at the rear of the computer, then plug the AC power cord into an outlet, and connect the AC power cord to the AC/DC adapter.
6. Use one hand to raise the lid/LCD to a comfortable viewing angle (do not exceed 130 degrees); use the other hand (as illustrated in [Figure 1](#)) to support the base of the computer (**Note: Never** lift the computer by the lid/LCD).
7. Press the power button to turn the computer "on".

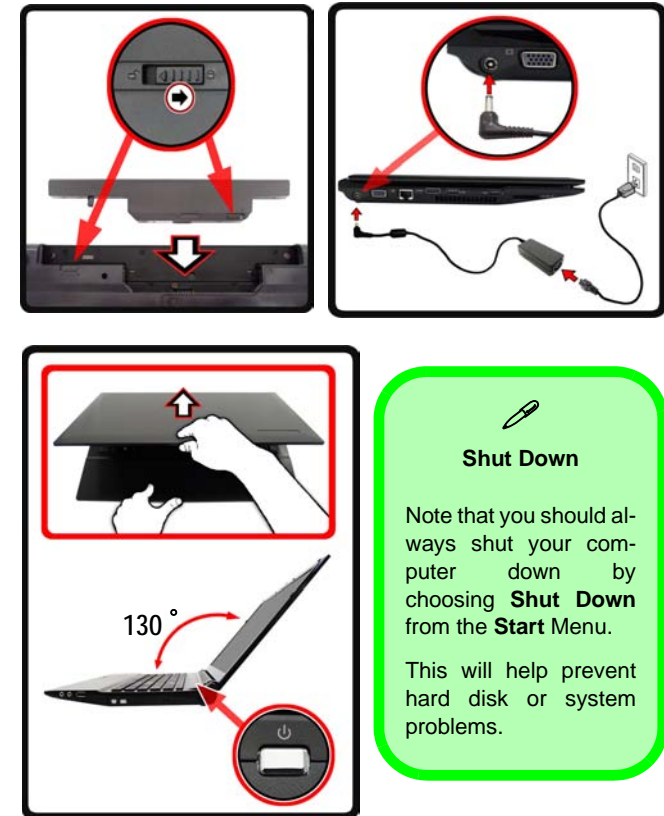

*Figure 1*  
Opening the Lid/LCD/  
Computer with AC/DC  
Adapter Plugged-In

## Contents

### Introduction .....1-1

Overview .....	1-1
Specifications .....	1-2
External Locator - Top View with LCD Panel Open .....	1-4
External Locator - Front & Right Side Views .....	1-5
External Locator - Left Side & Rear View .....	1-6
External Locator - Bottom View .....	1-7
Mainboard Overview - Top (Key Parts) .....	1-8
Mainboard Overview - Bottom (Key Parts) .....	1-9
Mainboard Overview - Top (Connectors) .....	1-10
Mainboard Overview - Bottom (Connectors) .....	1-11

### Disassembly .....2-1

Overview .....	2-1
Maintenance Tools .....	2-2
Connections .....	2-2
Maintenance Precautions .....	2-3
Disassembly Steps .....	2-4
Removing the Battery .....	2-5
Removing the Hard Disk Drive .....	2-6
Removing the Optical (CD/DVD) Device .....	2-8
Removing the System Memory (RAM) .....	2-9
Removing and Installing a Processor .....	2-11
Removing the Wireless LAN Module .....	2-14
Removing the Keyboard .....	2-15

### Part Lists .....A-1

Part List Illustration Location .....	A-2
Top (W251HU/W252HU/W255HU SERIES) .....	A-3
Top (W258HU SERIES) .....	A-4
Bottom .....	A-5

Combo .....	A-6
DVD .....	A-7
LCD (W25X HUQ) .....	A-8
LCD (W25X HUM) .....	A-9

### Schematic Diagrams.....B-1

System Block Diagram .....	B-2
CPU 1/7 (DMI, PEG, FDI) .....	B-3
CPU 2/7 (CLK, MISC, JTAG) .....	B-4
CPU 3/7 (DDR3) .....	B-5
CPU 4/7 (Power) .....	B-6
CPU 5/7 (Graphics Power) .....	B-7
CPU 6/7 (GND) .....	B-8
CPU 7/7 (RESERVED) .....	B-9
DDR3 SO-DIMM_0 .....	B-10
DDR3 SO-DIMM_1 .....	B-11
LVDS, Inverter .....	B-12
HDMI, CRT .....	B-13
CougarPoint - M 1/9 .....	B-14
CougarPoint - M 2/9 .....	B-15
CougarPoint - M 3/9 .....	B-16
CougarPoint - M 4/9 .....	B-17
CougarPoint - M 5/9 .....	B-18
CougarPoint - M 6/9 .....	B-19
CougarPoint - M 7/9 .....	B-20
CougarPoint - M 8/9 .....	B-21
CougarPoint - M 9/9 .....	B-22
New Card, Mini PCIE .....	B-23
CCD, 3G, TPM .....	B-24
Card Reader/LAN JMC251C .....	B-25
LAN (JMC251C), SATA HDD, ODD .....	B-26

## Preface

---

USB 3.0 NEC, USB Charger .....	B-27
KBC-ITE IT8518 .....	B-28
LED, MDC, BT .....	B-29
Audio Codec ALC269 .....	B-30
USB, Fan, TP, Multi-Conn .....	B-31
5VS, 3VS, 1.05VS, 1.5VS_CPU .....	B-32
VDD3, VDD5 .....	B-33
Power 1.5V/0.75V/1.8VS .....	B-34
Power 1.05VS .....	B-35
Power 0.85VS .....	B-36
Power V-Core1 .....	B-37
Power V-Core2 .....	B-38
Charger, DC In .....	B-39
Click Board .....	B-40
Audio Board/USB .....	B-41
Power Switch & LID Board .....	B-42
External ODD Board .....	B-43
Power Sequence .....	B-44

## Updating the FLASH ROM BIOS..... C-1

To update the FLASH ROM BIOS you must: C-1	
Download the BIOS .....	C-1
Unzip the downloaded files to a bootable CD/DVD/ or USB Flash drive .....	C-1
Set the computer to boot from the external drive .....	C-1
Use the flash tools to update the BIOS .....	C-2
Restart the computer (booting from the HDD) .....	C-2

# Chapter 1: Introduction

## Overview

This manual covers the information you need to service or upgrade the *W250HU/W250HUQ/W251HUQ-C/W252HUM/W252HUM-C/W255HU/W255HU-C/W255HUM/W255HUM-C/W258HUQ-C* series notebook computer. Information about operating the computer (e.g. getting started, and the *Setup* utility) is in the *User's Manual*. Information about drivers (e.g. VGA & audio) is also found in the *User's Manual*. The manual is shipped with the computer.

Operating systems (e.g. *Windows Vista/ Window 7*, etc.) have their own manuals as do application softwares (e.g. word processing and database programs). If you have questions about those programs, you should consult those manuals.

The *W250HU/W250HUQ/W251HUQ-C/W252HUM/W252HUM-C/W255HU/W255HU-C/W255HUM/W255HUM-C/W258HUQ-C* series notebook is designed to be upgradeable. See *Disassembly on page 2 - 1* for a detailed description of the upgrade procedures for each specific component. Please take note of the warning and safety information indicated by the “⚠” symbol.

The balance of this chapter reviews the computer's technical specifications and features.

## Introduction

# Specifications



### Latest Specification Information

The specifications listed here are correct at the time of sending them to the press. Certain items (particularly processor types/speeds) may be changed, delayed or updated due to the manufacturer's release schedule. Check with your service center for more details.



### CPU

The CPU is not a user serviceable part. Accessing the CPU in any way may violate your warranty.

### Processor Options

#### Intel® Core™ i7 Processor

##### i7-2620M (2.70GHz)

4MB L3 Cache, 32nm, DDR3-1333MHz, TDP 35W

#### Intel® Core™ i5 Processor

##### i5-2540M (2.60GHz), i5-2520M (2.50GHz),

##### i5-2410M (2.30GHz)

3MB L3 Cache, 32nm, DDR3-1333MHz, TDP 35W

#### Intel® Core™ i3 Processor

##### i3-2310M (2.10GHz)

3MB L3 Cache, 32nm, DDR3-1333MHz, TDP 35W

### Core Logic

Intel® HM65 Chipset

### LCD

15.6" (39.62cm) HD/HD+ TFT LCD

### Memory

Two 204 Pin SO-DIMM Sockets Supporting **DDR3 1066/1333MHz** Memory

Memory Expandable up to 8GB

### Video Adapter

#### Intel® HM65 Integrated Video

Shared Memory Architecture of up to **1748MB**

MS DirectX® 10 compatible

### BIOS

One 32Mb SPI Flash ROM

AMI BIOS

### Security

Security (Kensington® Type) Lock Slot

BIOS Password

### Storage

(**Factory Option**) One Changeable 12.7mm(h) Optical Device Type Drive (Super Multi Drive Module or Blu-Ray Combo Drive Module)

One Changeable 2.5" 9.5 mm (h) SATA HDD

### Audio

High Definition Audio Compliant Interface

2 \* Built-In Speakers

Built-In Microphone

### Communication

Built-In Gigabit Ethernet LAN

(**Factory Option**) 300K/1.3M Pixel USB PC Camera Module

(**Factory Option**) 3.75G/HSPA Mini-Card Module

#### WLAN/ Bluetooth Half Mini-Card Modules:

(**Factory Option**) Intel® Centrino® Wireless-N 100 (**802.11b/g/n**)

(**Factory Option**) Intel® Centrino® Wireless-N 130 Wireless LAN (**802.11b/g/n**) + Bluetooth 3.0

(**Factory Option**) Intel® Centrino® Wireless-N 1030 Wireless LAN (**802.11b/g/n**) + Bluetooth 3.0

(**Factory Option**) Third-Party Wireless LAN (**802.11b/g/n**)

(**Factory Option**) Third-Party Wireless LAN (**802.11b/g/n**) + Bluetooth 3.0

### Keyboard

Full-size "WinKey" keyboard (with numeric keypad)

### Pointing Device

Built-in Touchpad

### Mini Card Slots

Slot 1 for **WLAN** Module or Combo **WLAN and Bluetooth** Module

(**Factory Option**) Slot 2 for **3.75G/HSPA** Module

### Interface

Three USB 2.0 Ports  
One HDMI-Out Port  
One Headphone-Out Jack  
One Microphone-In Jack  
One RJ-45 LAN Jack  
One DC-in Jack  
One External Monitor Port

### Card Reader

Embedded Multi-In-1 Card Reader  
MMC (MultiMedia Card) / RS MMC  
SD (Secure Digital) / Mini SD / SDHC/ SDXC  
MS (Memory Stick) / MS Pro / MS Duo

### Power

6 Cell Smart Lithium-Ion Battery Pack, 48.84WH  
**(Factory Option)** 6 Cell Smart Lithium-Ion Battery Pack,  
62.16WH  
**(Factory Option)** 4 Cell Smart Lithium-Ion Battery Pack,  
32.56WH

Full Range AC/DC Adapter  
AC Input: 100 - 240V, 50 - 60Hz  
DC Output: 19V, 3.42A or 18.5V, 3.5A **(65W)**

Energy Star 5.0 Compliant

### Environmental Spec

#### Temperature

Operating: 5°C - 35°C  
Non-Operating: -20°C - 60°C

#### Relative Humidity

Operating: 20% - 80%  
Non-Operating: 10% - 90%

### Dimensions & Weight

374mm (w) \* 250mm (d) \* 14.3 - 34.1mm (h)  
2.3 kg (with 48.84WH Battery and ODD)  
Or  
374mm (w) \* 250mm (d) \* 14.3 - 35.3mm (h)  
2.3 kg (with 48.84WH Battery and ODD)

## Introduction

# External Locator - Top View with LCD Panel Open

*Figure 1*  
Top View

1. PC Camera  
(Optional)
2. LCD
3. Power Button
4. LED Status Indicators
5. Keyboard
6. Built-In Microphone
7. Touchpad & Buttons





## External Locator - Front & Right Side Views

FRONT VIEW



RIGHT SIDE VIEW



*Figure 2*  
**Front View**

1. LED Power Indicator

*Figure 3*  
**Right Side View**

1. Microphone-In Jack
2. Headphone-Out Jack
3. USB 2.0 Port
4. Optical Device Drive Bay
5. Emergency Eject Hole

## Introduction

### External Locator - Left Side & Rear View

*Figure 4*  
**Left Side View**

1. DC-In Jack
2. External Monitor Port
3. RJ-45 LAN Jack
4. HDMI-Out Port
5. USB 2.0 Port
6. Vent
7. USB 2.0 Port
8. Multi-in-1 Card Reader

LEFT SIDE VIEW



*Figure 5*  
**Rear View**

1. Security Lock Slot
2. Battery

REAR VIEW



## External Locator - Bottom View

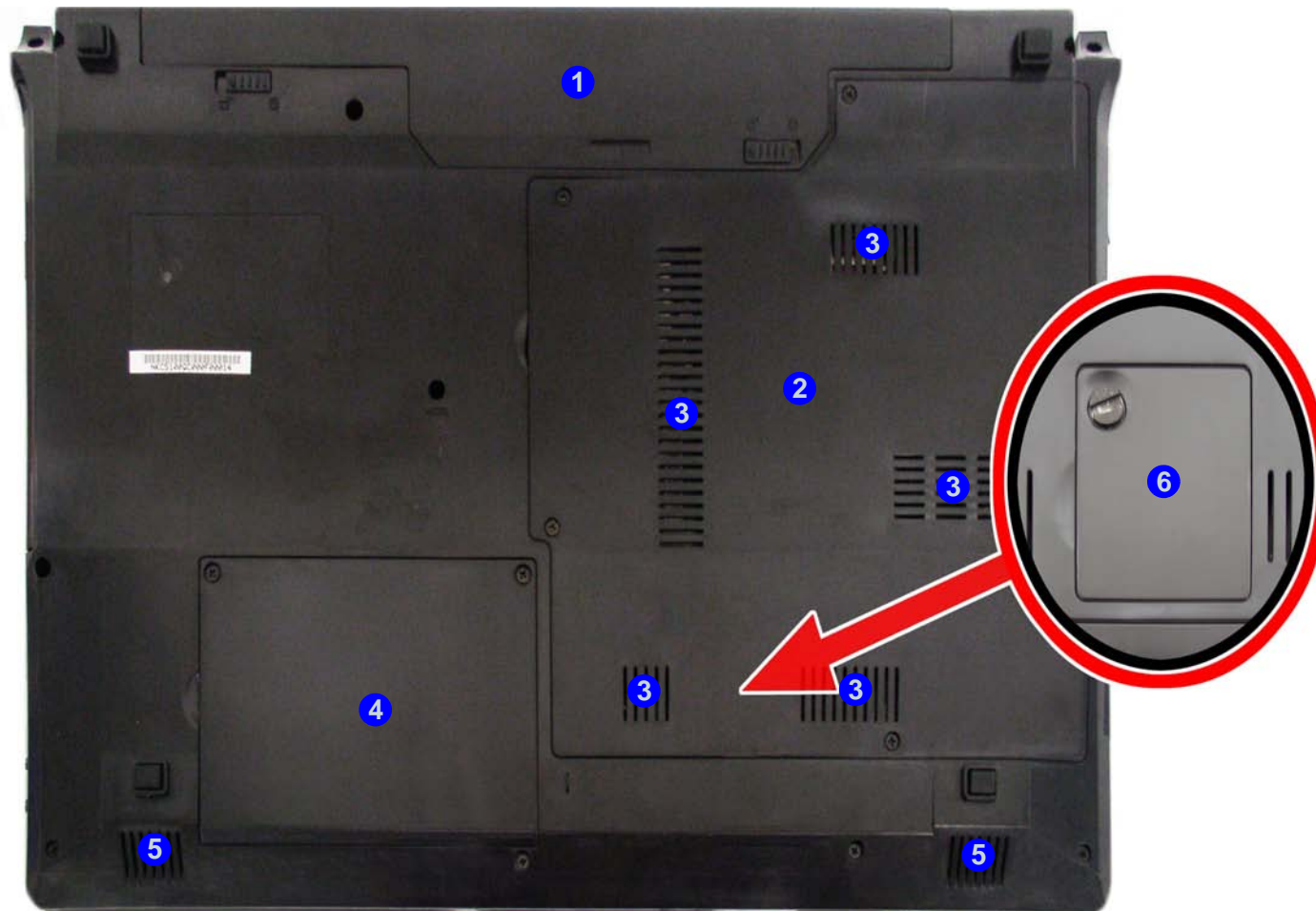

*Figure 6*  
**Bottom View**

1. Battery
2. Component Bay Cover
3. Vent
4. Hard Disk Bay Cover
5. Speakers
6. USIM Card Cover



### Overheating

To prevent your computer from overheating, make sure nothing blocks any vent while the computer is in use.

## Introduction

*Figure 7*  
**Mainboard Top  
Key Parts**

1. KBC-ITE IT8518
2. Audio Codec  
ALC269

## Mainboard Overview - Top (Key Parts)

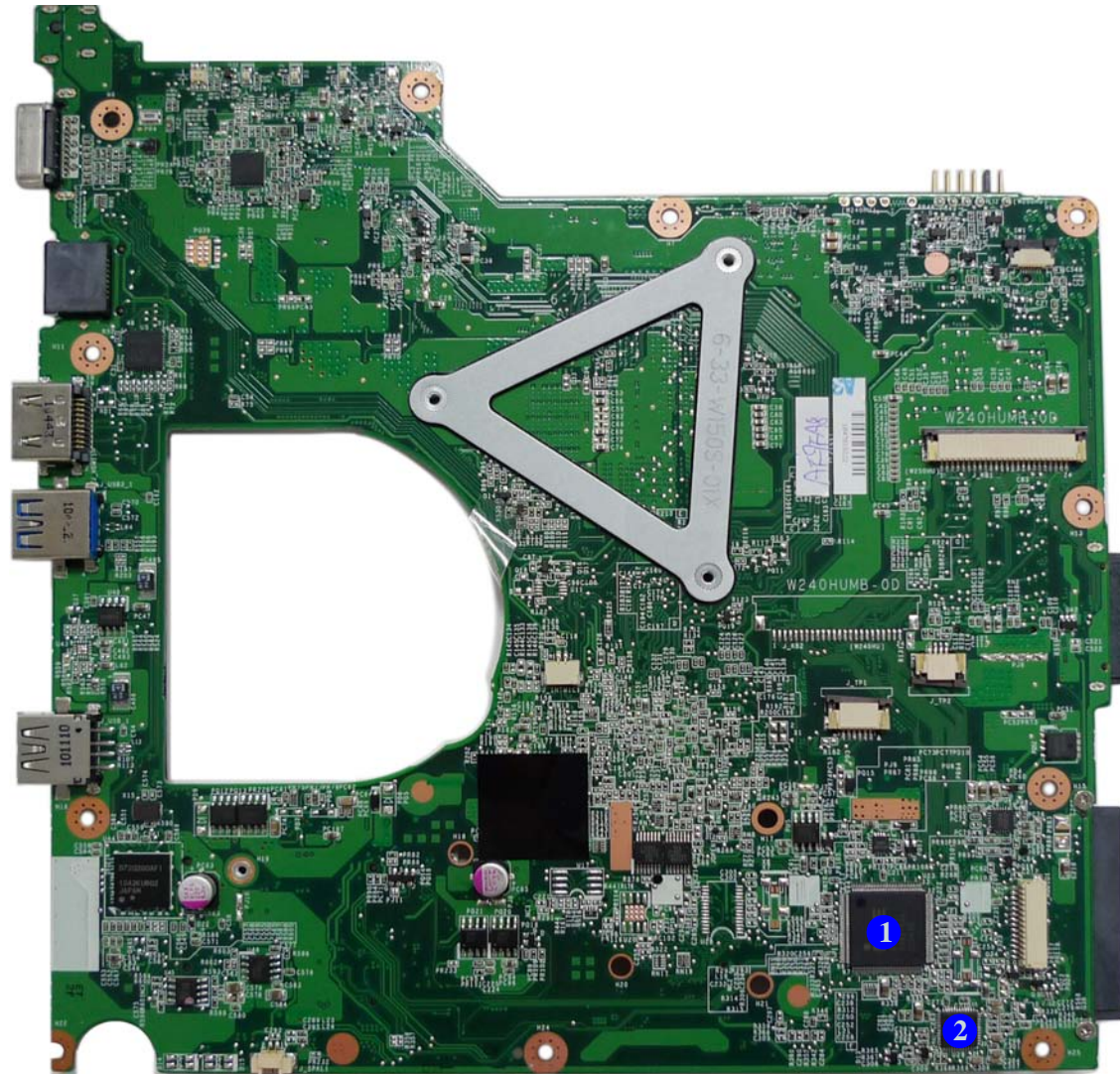

## Mainboard Overview - Bottom (Key Parts)

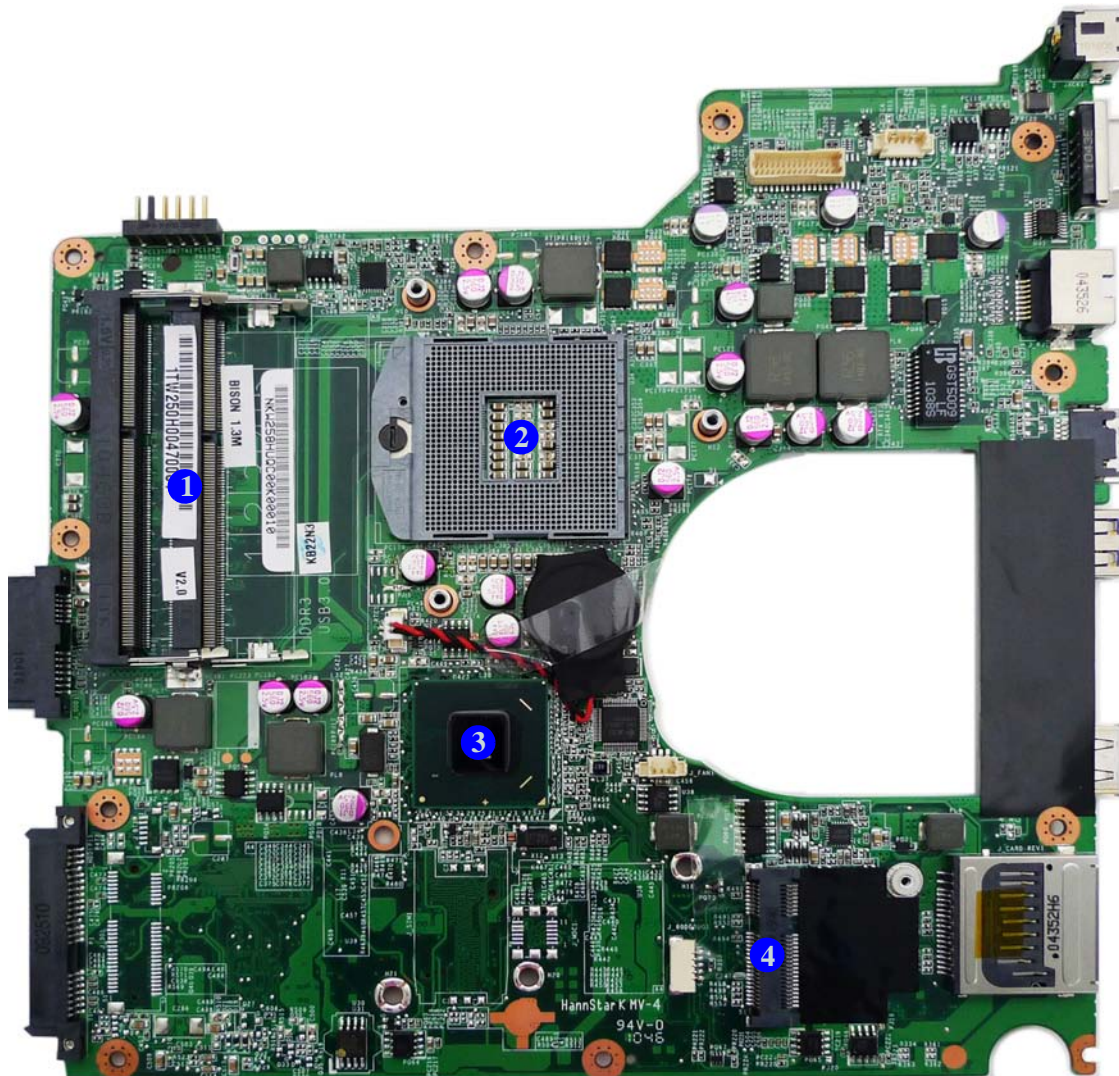

*Figure 8*  
**Mainboard Bottom  
Key Parts**

1. Memory Slots  
DDR3 SO-DIMM
2. CPU Socket (no  
CPU installed)
3. Platform Controller  
Hub
4. Mini-Card  
Connector (WLAN  
Module)

## Introduction

*Figure 9*  
**Mainboard Top  
Connectors**

1. HDMI-Out Port
2. USB Port 2.0
3. USB 2.0 Port
4. Speaker Cable Connector
5. Microphone Cable Connector
6. Audio Board Connector
7. TouchPad Cable Connector 1
8. TouchPad Cable Connector 2
9. Keyboard Cable Connector
10. Switch Board Cable Connector

## Mainboard Overview - Top (Connectors)

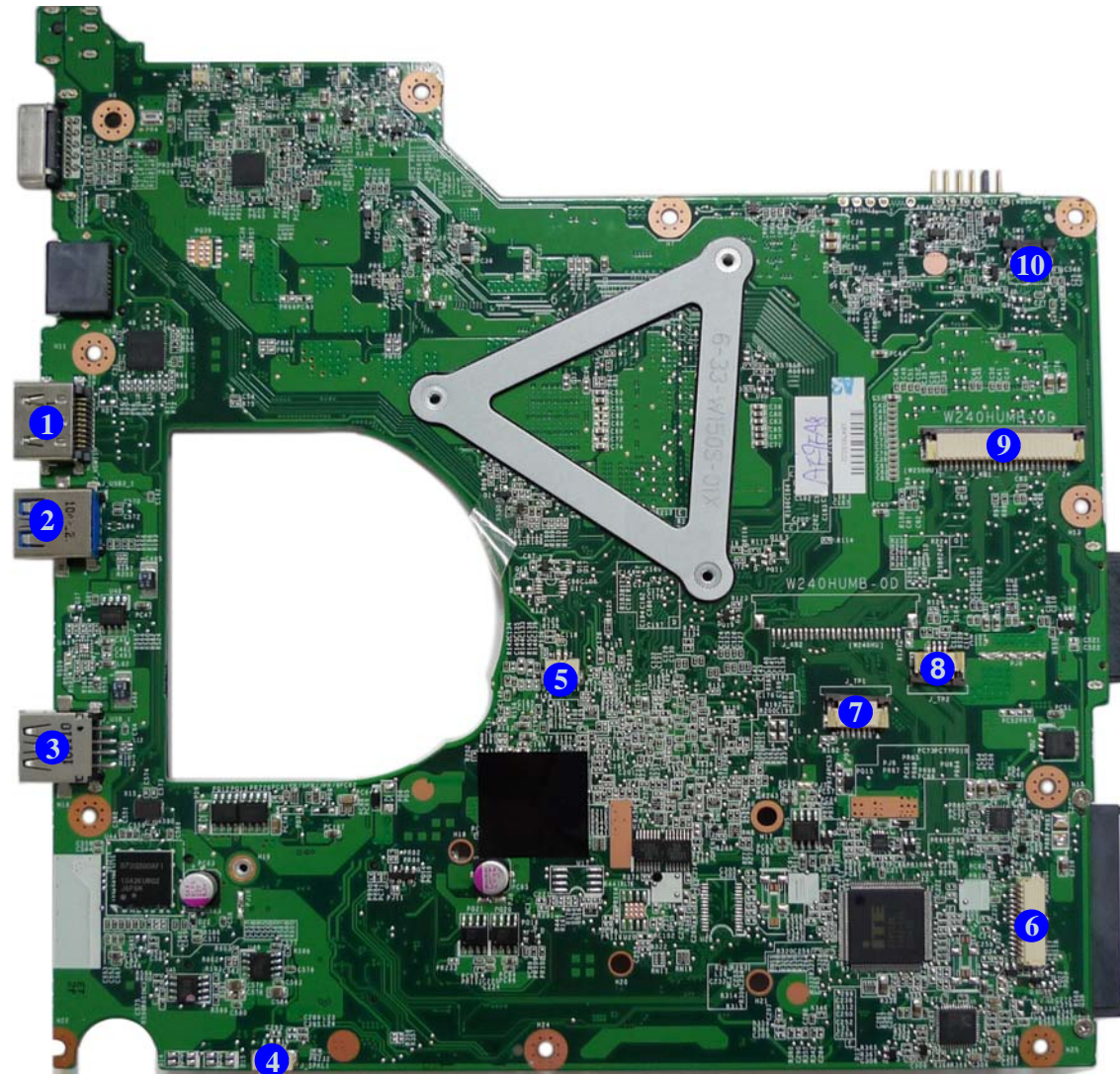

## Mainboard Overview - Bottom (Connectors)

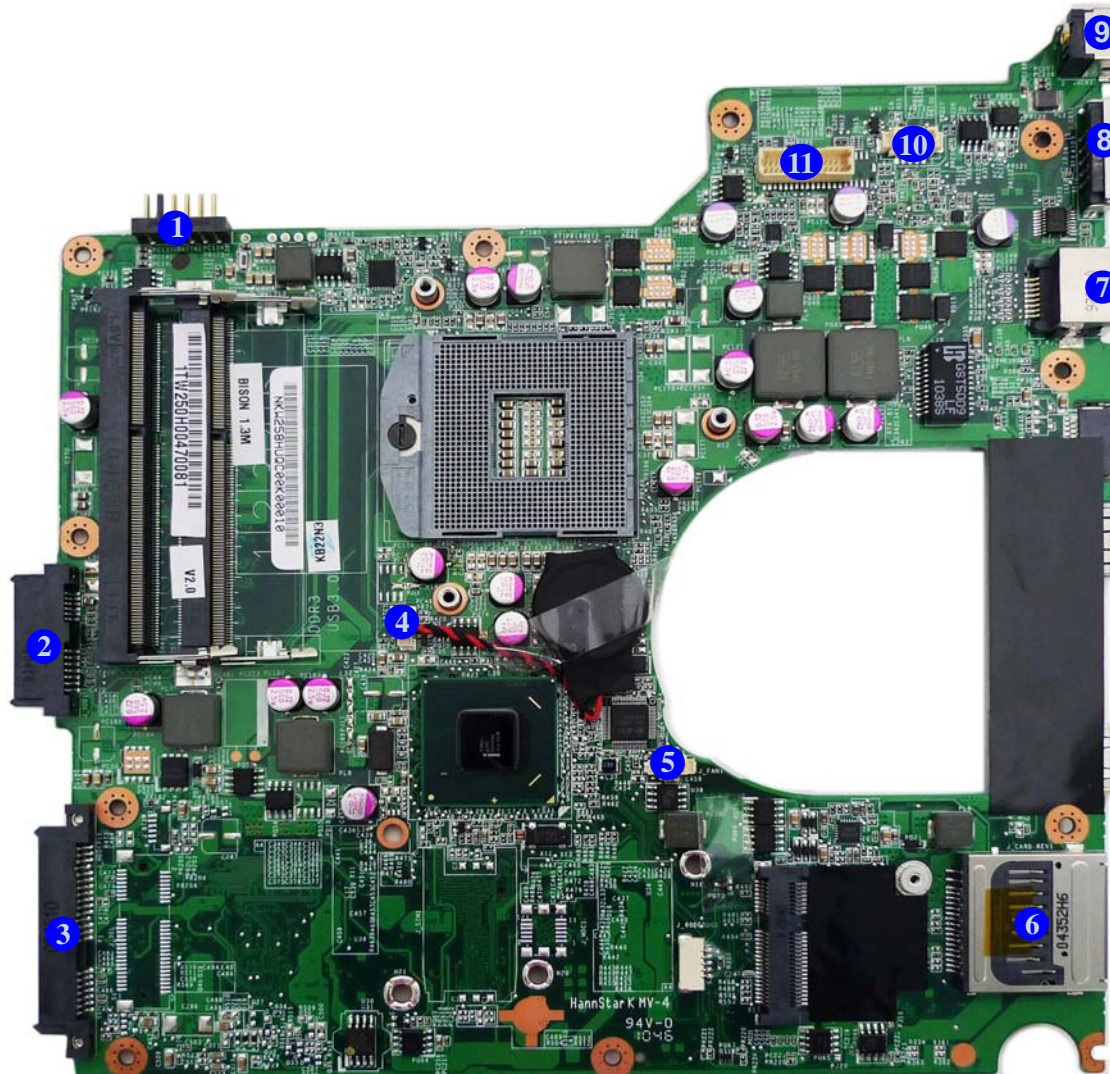

*Figure 10*  
**Mainboard Bottom  
Connectors**

1. Battery Connector
2. ODD Connector
3. HDD Connector
4. CMOS Battery Connector
5. CPU Fan Cable Connector
6. Multi-in-1 Card Reader
7. RJ-45 LAN Jack
8. External Monitor Port
9. DC-In Jack
10. CCD Cable Connector
11. LCD Cable Connector





# Chapter 2: Disassembly



## Overview

This chapter provides step-by-step instructions for disassembling the *W250HU/W250HUQ/W251HUQ-C/W252HUM/W252HUM-C/W255HU/W255HU-C/W255HUM/W255HUM-C/W258HUQ-C* series notebook's parts and subsystems. When it comes to reassembly, reverse the procedures (unless otherwise indicated).

We suggest you completely review any procedure before you take the computer apart.

Procedures such as upgrading/replacing the RAM, optical device and hard disk are included in the User's Manual but are repeated here for your convenience.

To make the disassembly process easier each section may have a box in the page margin. Information contained under the figure # will give a synopsis of the sequence of procedures involved in the disassembly procedure. A box with a  lists the relevant parts you will have after the disassembly process is complete. **Note:** The parts listed will be for the disassembly procedure listed ONLY, and not any previous disassembly step(s) required. Refer to the part list for the previous disassembly procedure. The amount of screws you should be left with will be listed here also.

A box with a  will also provide any possible helpful information. A box with a  contains warnings.

An example of these types of boxes are shown in the sidebar.

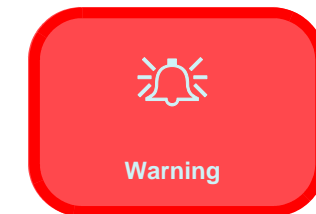
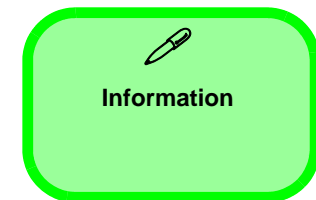

## Disassembly

---

**NOTE:** All disassembly procedures assume that the system is turned **OFF**, and disconnected from any power supply (the battery is removed too).

### Maintenance Tools

The following tools are recommended when working on the notebook PC:

- M3 Philips-head screwdriver
- M2.5 Philips-head screwdriver (magnetized)
- M2 Philips-head screwdriver
- Small flat-head screwdriver
- Pair of needle-nose pliers
- Anti-static wrist-strap

### Connections

Connections within the computer are one of four types:

Locking collar sockets for ribbon connectors	To release these connectors, use a small flat-head screwdriver to gently pry the locking collar away from its base. When replacing the connection, make sure the connector is oriented in the same way. The pin1 side is usually not indicated.
Pressure sockets for multi-wire connectors	To release this connector type, grasp it at its head and gently rock it from side to side as you pull it out. Do not pull on the wires themselves. When replacing the connection, do not try to force it. The socket only fits one way.
Pressure sockets for ribbon connectors	To release these connectors, use a small pair of needle-nose pliers to gently lift the connector away from its socket. When replacing the connection, make sure the connector is oriented in the same way. The pin1 side is usually not indicated.
Board-to-board or multi-pin sockets	To separate the boards, gently rock them from side to side as you pull them apart. If the connection is very tight, use a small flat-head screwdriver - use just enough force to start.

## Maintenance Precautions

The following precautions are a reminder. To avoid personal injury or damage to the computer while performing a removal and/or replacement job, take the following precautions:

1. **Don't drop it.** Perform your repairs and/or upgrades on a stable surface. If the computer falls, the case and other components could be damaged.
2. **Don't overheat it.** Note the proximity of any heating elements. Keep the computer out of direct sunlight.
3. **Avoid interference.** Note the proximity of any high capacity transformers, electric motors, and other strong magnetic fields. These can hinder proper performance and damage components and/or data. You should also monitor the position of magnetized tools (i.e. screwdrivers).
4. **Keep it dry.** This is an electrical appliance. If water or any other liquid gets into it, the computer could be badly damaged.
5. **Be careful with power.** Avoid accidental shocks, discharges or explosions.
  - Before removing or servicing any part from the computer, turn the computer off and detach any power supplies.
  - When you want to unplug the power cord or any cable/wire, be sure to disconnect it by the plug head. Do not pull on the wire.
6. **Peripherals** – Turn off and detach any peripherals.
7. **Beware of static discharge.** ICs, such as the CPU and main support chips, are vulnerable to static electricity. Before handling any part in the computer, discharge any static electricity inside the computer. When handling a printed circuit board, do not use gloves or other materials which allow static electricity buildup. We suggest that you use an anti-static wrist strap instead.
8. **Beware of corrosion.** As you perform your job, avoid touching any connector leads. Even the cleanest hands produce oils which can attract corrosive elements.
9. **Keep your work environment clean.** Tobacco smoke, dust or other air-borne particulate matter is often attracted to charged surfaces, reducing performance.
10. **Keep track of the components.** When removing or replacing any part, be careful not to leave small parts, such as screws, loose inside the computer.

## Cleaning

Do not apply cleaner directly to the computer, use a soft clean cloth.

Do not use volatile (petroleum distillates) or abrasive cleaners on any part of the computer.



### Power Safety Warning

Before you undertake any upgrade procedures, make sure that you have turned off the power, and disconnected all peripherals and cables (including telephone lines). It is advisable to also remove your battery in order to prevent accidentally turning the machine on.

### Disassembly Steps

The following table lists the disassembly steps, and on which page to find the related information. **PLEASE PERFORM THE DISASSEMBLY STEPS IN THE ORDER INDICATED.**

#### To remove the Battery:

1. Remove the battery *page 2 - 5*

#### To remove the HDD:

1. Remove the battery *page 2 - 5*
2. Remove the HDD *page 2 - 6*

#### To remove the Optical Device:

1. Remove the battery *page 2 - 5*
2. Remove the Optical device *page 2 - 8*

#### To remove the System Memory:

1. Remove the battery *page 2 - 5*
2. Remove the system memory *page 2 - 9*

#### To remove and install a Processor:

1. Remove the battery *page 2 - 5*
2. Remove the processor *page 2 - 11*
3. Install the processor *page 2 - 13*

#### To remove the Wireless LAN Module:

1. Remove the battery *page 2 - 5*
2. Remove the WLAN module *page 2 - 14*

#### To remove the Keyboard:

1. Remove the battery *page 2 - 5*
2. Remove the keyboard *page 2 - 15*

## Removing the Battery

1. Turn the computer **off**, and turn it over.
2. Slide the latch **1** in the direction of the arrow (*Figure 1a*).
3. Slide the latch **2** in the direction of the arrow, and hold it in place (*Figure 1a*).
4. Slide the battery **3** in the direction of the arrow **4** (*Figure 1b*).

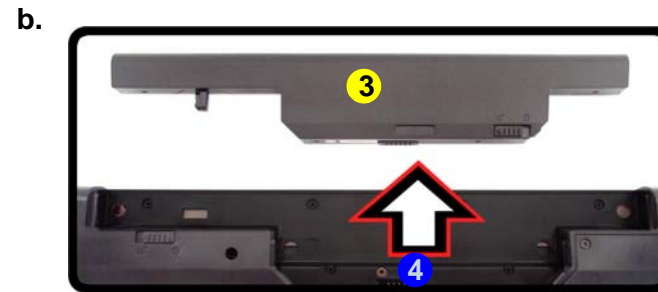
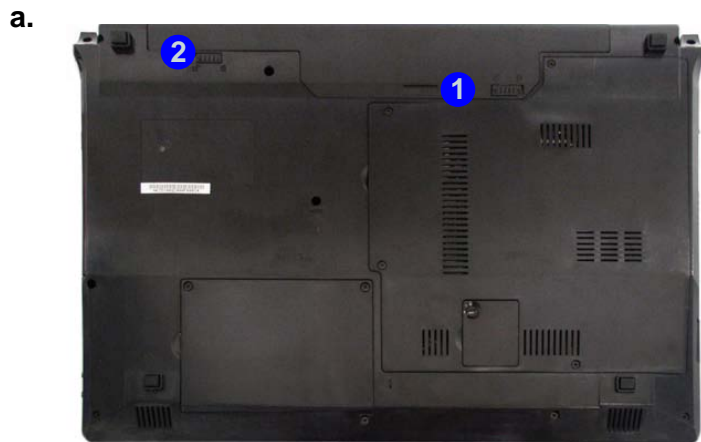

*Figure 1*  
**Battery Removal**

- a. Slide the latch and hold it in place.
- b. Slide the battery in the direction of the arrow.

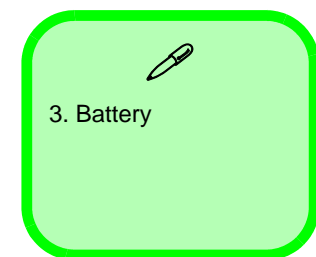

# Removing the Hard Disk Drive

*Figure 2*  
**HDD Assembly  
Removal**

The hard disk drive can be taken out to accommodate other 2.5" serial (SATA) hard disk drives with a height of 9.5mm (h). Follow your operating system's installation instructions, and install all necessary drivers and utilities (as outlined in **Chapter 4 of the User's Manual**) when setting up a new hard disk.

- a. Locate the HDD bay cover and remove the screws.

### Hard Disk Upgrade Process

1. Turn **off** the computer, and remove the battery ([page 2 - 5](#)).
2. Locate the hard disk bay cover and remove screws **1** & **2** ([Figure 2a](#)).

a.

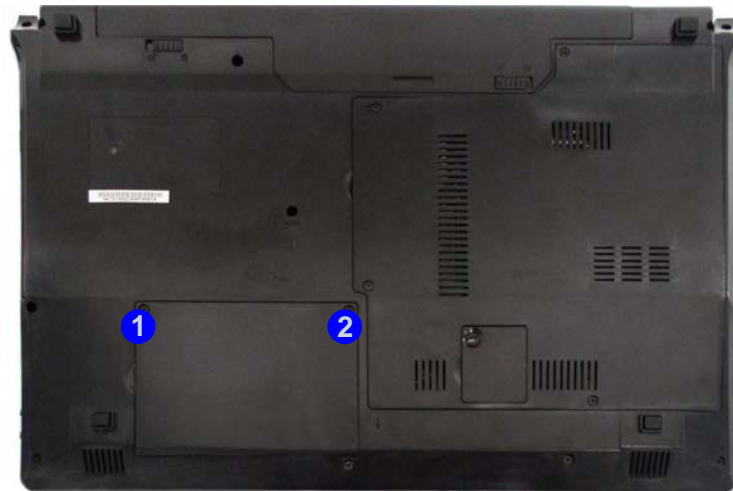

#### HDD System Warning

New HDD's are blank. Before you begin make sure:

You have backed up any data you want to keep from your old HDD.

You have all the CD-ROMs and FDDs required to install your operating system and programs.

If you have access to the internet, download the latest application and hardware driver updates for the operating system you plan to install. Copy these to a removable medium.



- 2 Screws

- Remove the hard disk bay cover **3** (*Figure 3b*).
- Grip the tab and slide the hard disk in the direction of arrow **4** (*Figure 3c*).
- Lift the hard disk assembly **5** out of the bay **6** (*Figure 3d*).
- Remove the screw **7** - **10** and the mylar cover **11** from the hard disk **12** (*Figure 3e*).
- Reverse the process to install a new hard disk (do not forget to replace all the screws and covers).

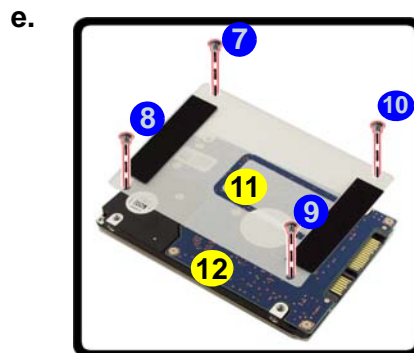
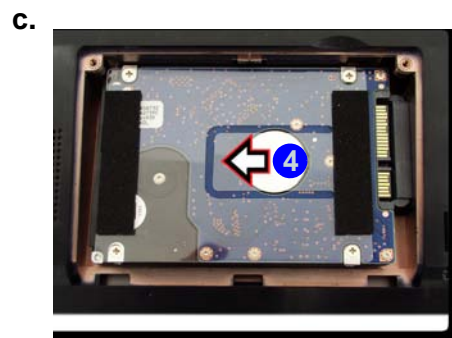
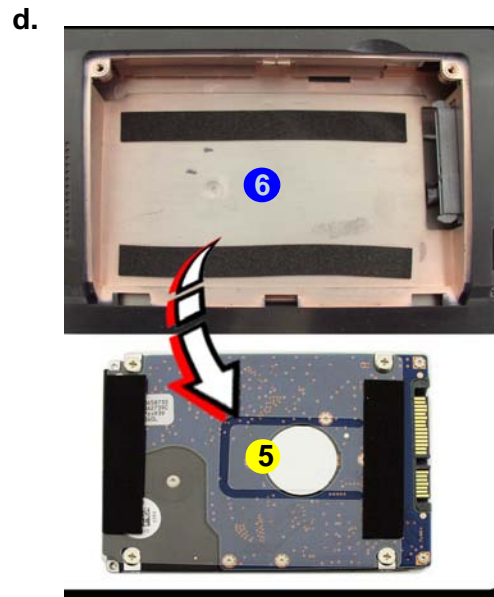
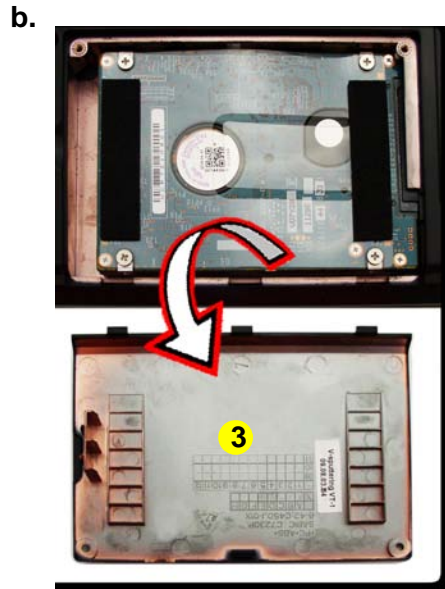

*Figure 3*  
**HDD Assembly  
Removal (cont'd.)**

- Remove the HDD bay cover.
- Grip the tab and slide the HDD assembly in the direction of the arrow.
- Lift the HDD assembly out of the bay.
- Remove the screws and mylar cover.



## Disassembly

### Figure 4 Optical Device Removal

- Remove the screw at point ①.
- Use a screwdriver to carefully push out the optical device at point ②.

## Removing the Optical (CD/DVD) Device

- Turn off the computer, remove the battery ([page 2 - 5](#)) and hard disk ([page 2 - 6](#)).
- Remove the screw at point ① ([Figure 4a](#)).
- Use a screwdriver to carefully push out the optical device ③ at point ② ([Figure 4b](#)).
- Insert the new device and carefully slide it into the computer (the device only fits one way. DO NOT FORCE IT; The screw holes should line up).
- Restart the computer to allow it to automatically detect the new device.

a.



b.



3. Optical Device

- 1 Screw



## Removing the System Memory (RAM)

The computer has two memory sockets for 204 pin Small Outline Dual In-line Memory Modules (SO-DIMM) supporting DDRIII (DDR3) Up to 1066/1333 MHz. The main memory can be expanded up to 8GB. The SO-DIMM modules supported are 1024MB and 2048MB **DDRIII** Modules. The total memory size is automatically detected by the POST routine once you turn on your computer.

### Memory Upgrade Process

1. Turn **off** the computer, turn it over and remove the battery ([page 2 - 5](#)).
2. Remove screws **1** - **4** from the component bay cover ([Figure 5a](#)).
3. The RAM modules will be visible at point **5** on the mainboard ([Figure 5b](#)).
4. Gently pull the two release latches (**6** & **7**) on the sides of the memory socket in the direction indicated by the arrows ([Figure 5c](#)). The RAM module **8** will pop-up ([Figure 5d](#)), and you can then remove it.

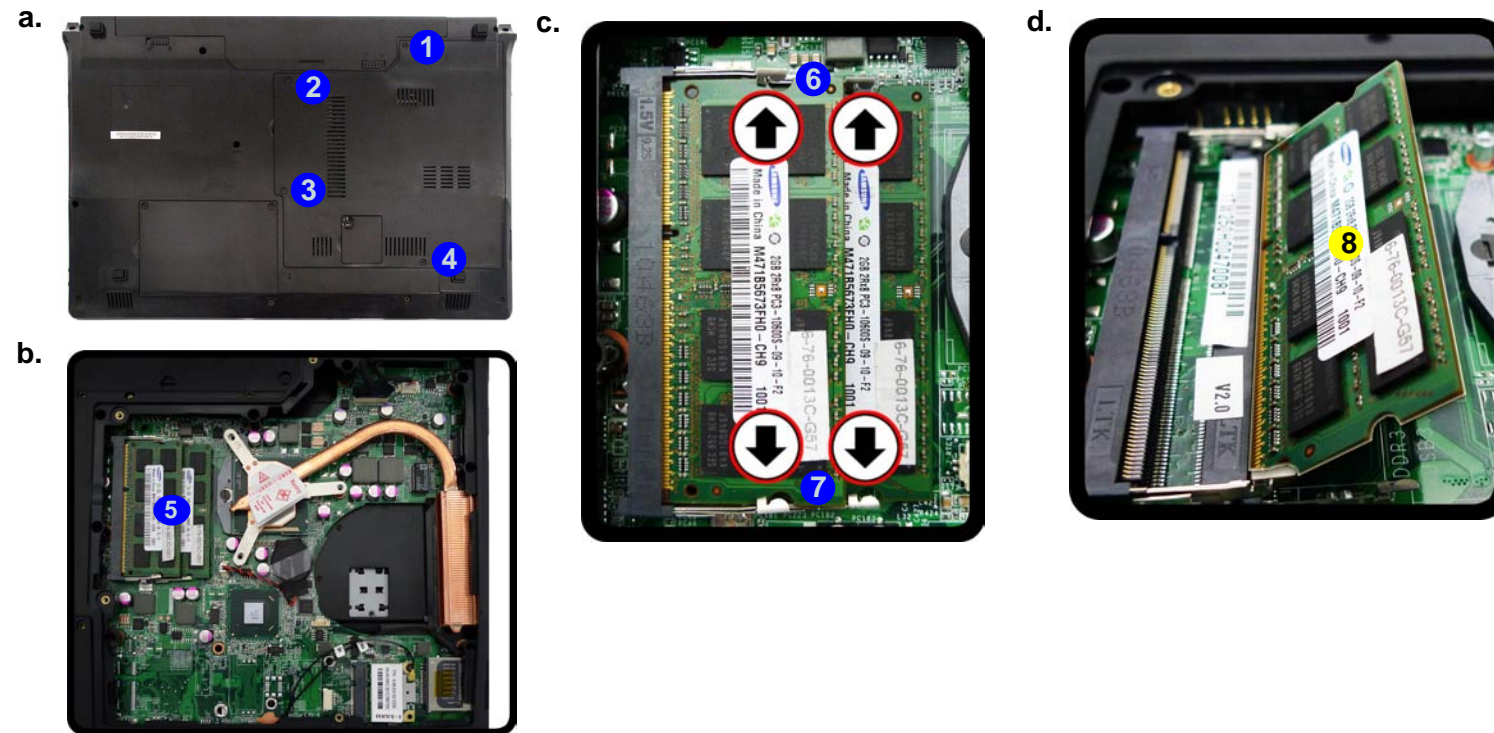

*Figure 5*  
**RAM Module Removal**

- a. Remove the screws from the component bay cover.
- b. The RAM modules will be visible at point **5** on the mainboard.
- c. Pull the release latches.
- d. Remove the module.

  
**Contact Warning**

Be careful not to touch the metal pins on the module's connecting edge. Even the cleanest hands have oils which can attract particles, and degrade the module's performance.



8. RAM Module

- 4 Screws

## Disassembly

---

5. Pull the latches to release the second module if necessary.
6. Insert a new module holding it at about a 30° angle and fit the connectors firmly into the memory slot.
7. The module will only fit one way as defined by its pin alignment. Make sure the module is seated as far into the slot as it will go. DO NOT FORCE IT; it should fit without much pressure.
8. Press the module in and down towards the mainboard until the slot levers click into place to secure the module.
9. Replace the component bay cover and the screws (see [page 2 - 9](#)).
10. Restart the computer to allow the BIOS to register the new memory configuration as it starts up.

# Removing and Installing a Processor

## Processor Removal Procedure

1. Turn **off** the computer, turn it over, and remove the battery ([page 2 - 5](#)) and the component bay cover ([page 2 - 8](#)).
2. The CPU heat sink will be visible at point **A** ([Figure 6a](#)).
3. Loosen the CPU heat sink screws in the order **3**, **2** & **1** (the reverse order as indicated on the label [Figure 6a](#)).
4. Grip the heat sink tab and carefully lift the heat sink **4** up and off the computer ([Figure 6b](#)).

*Figure 6*  
**Processor Removal**

- a. The CPU heat sink will be visible at point **A**. Remove the screws from the CPU heatsink.
- b. Grip the heat sink tab and carefully lift the heat sink up and off the computer.

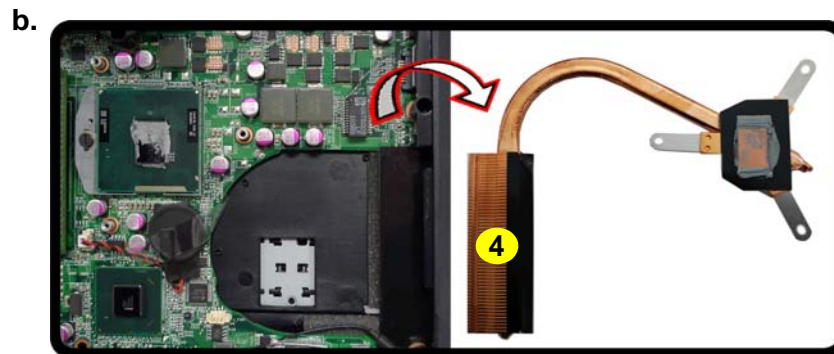
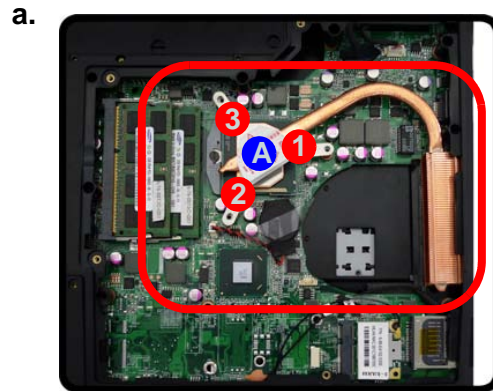



4. Heat Sink

- 3 Screws

## Disassembly

### Figure 7 Processor Removal (cont'd)

- c. Turn the release latch to unlock the CPU.  
d. Lift the CPU out of the socket.

5. Turn the release latch **5** towards the unlock symbol  to release the CPU (*Figure 7d*).
6. Carefully (it may be hot) lift the CPU **6** up and out of the socket (*Figure 7e*).
7. Reverse the process to install a new CPU.
8. When re-inserting the CPU, pay careful attention to the pin alignment, it will fit only one way (DO NOT FORCE IT!).

c.

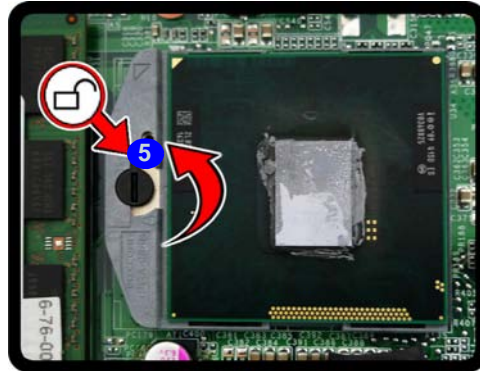

Unlock

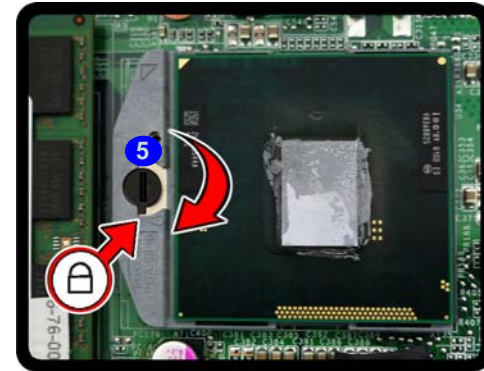

Lock

d.

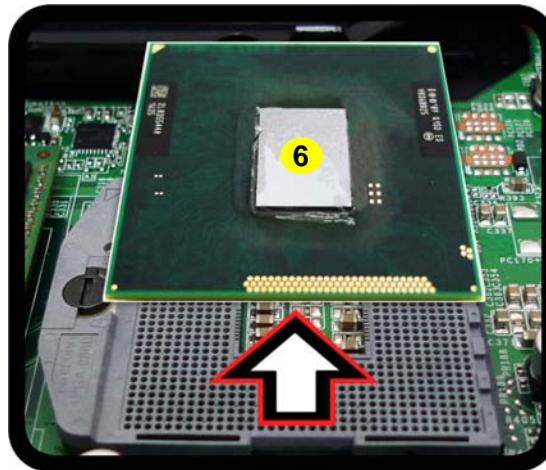

#### Caution

The heat sink, and CPU area in general, contains parts which are subject to high temperatures. Allow the area time to cool before removing these parts.

6. CPU

**Processor Installation Procedure**

1. Insert the CPU **A** (*Figure 8a*), pay careful attention to the pin alignment, it will fit only one way (DO NOT FORCE IT!), and turn the release latch **B** towards the lock symbol  (*Figure 8b*).
2. **Remove the sticker C** (*Figure 8c*) from the heat sink.
3. Insert the heat sink **D** as indicated in *Figure 8d*.
4. Tighten the CPU heat sink screws in the order **1**, **2** & **3** (the order as indicated on the label and *Figure 8d*).
5. Replace the component bay cover (don't forget to replace the fan cable) and tighten the screws (*page 2 - 9*).

*Figure 8*  
**Processor Installation**

- a. Insert the CPU.
- b. Turn the release latch towards the lock symbol.
- c. Remove the sticker from the heat sink and insert the heat sink.
- d. Tighten the screws.

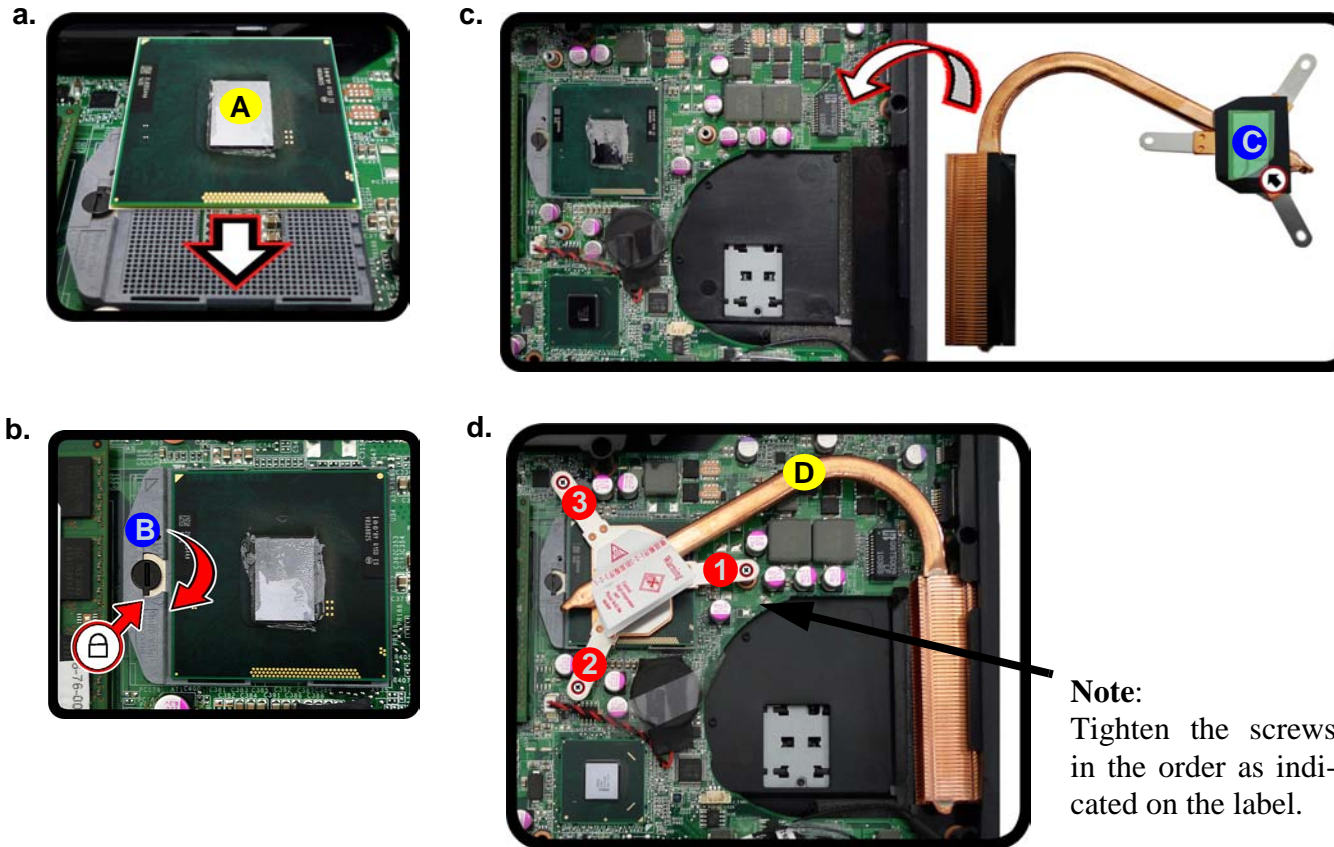

**Note:**  
Tighten the screws in the order as indicated on the label.



A. CPU  
D. Heat Sink

- 3 Screws

## Disassembly

### Figure 9 Wireless LAN Module Removal

- Locate the WLAN.
- Disconnect the cable and remove the screw.
- The WLAN module will pop up.
- Remove the Wireless LAN module.

Note: Make sure you reconnect the antenna cable to the “1 + 2” socket (Figure 9b).

## Removing the Wireless LAN Module

- Turn **off** the computer, turn it over, and remove the battery (page 2 - 5) and the component bay cover (page 2 - 9).
- The Wireless LAN module will be visible at point ① on the mainboard (Figure 9a).
- Carefully disconnect the cable ②, and then remove the screw ③ (Figure 9b).
- The Wireless LAN module ④ (Figure 9c) will pop-up, and you can remove it from the computer (Figure 9d).

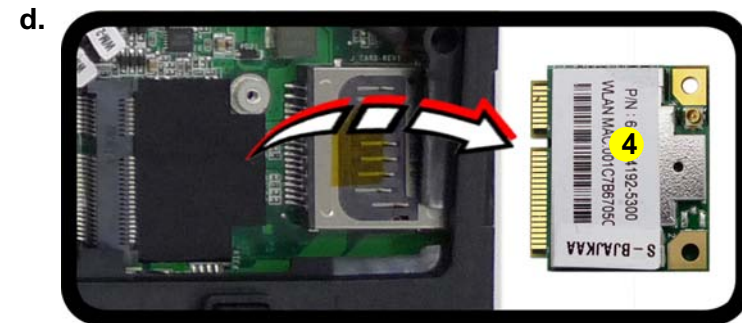
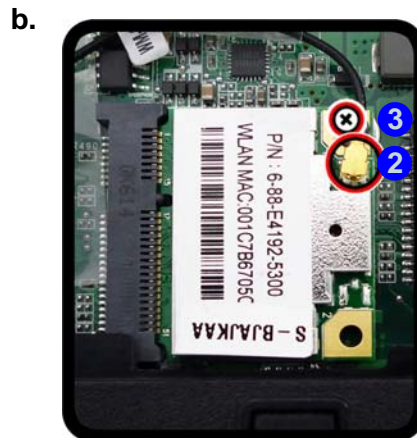
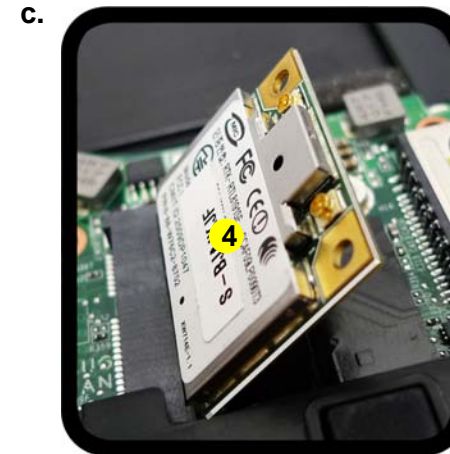

#### 4. Wireless LAN Module

- 1 Screw

## Removing the Keyboard

1. Turn **off** the computer, and remove the battery ([page 2 - 5](#)).
2. Remove screws **1** - **4** from the bottom of the computer. Press at points **5** to unsnap the LED cover module **6** (you may need to use the Eject Pin Tool to do this ([Figure 10a](#))).
3. Remove the LED cover module **6** and screws **7** - **11** from the keyboard ([Figure 10b](#)).
4. Carefully lift the keyboard up, being careful not to bend the keyboard ribbon cable **12**. Disconnect the keyboard ribbon cable **12** from the locking collar socket **13** ([Figure 10c](#)).
5. Carefully lift up the keyboard **14** ([Figure 10d](#)) off the computer.

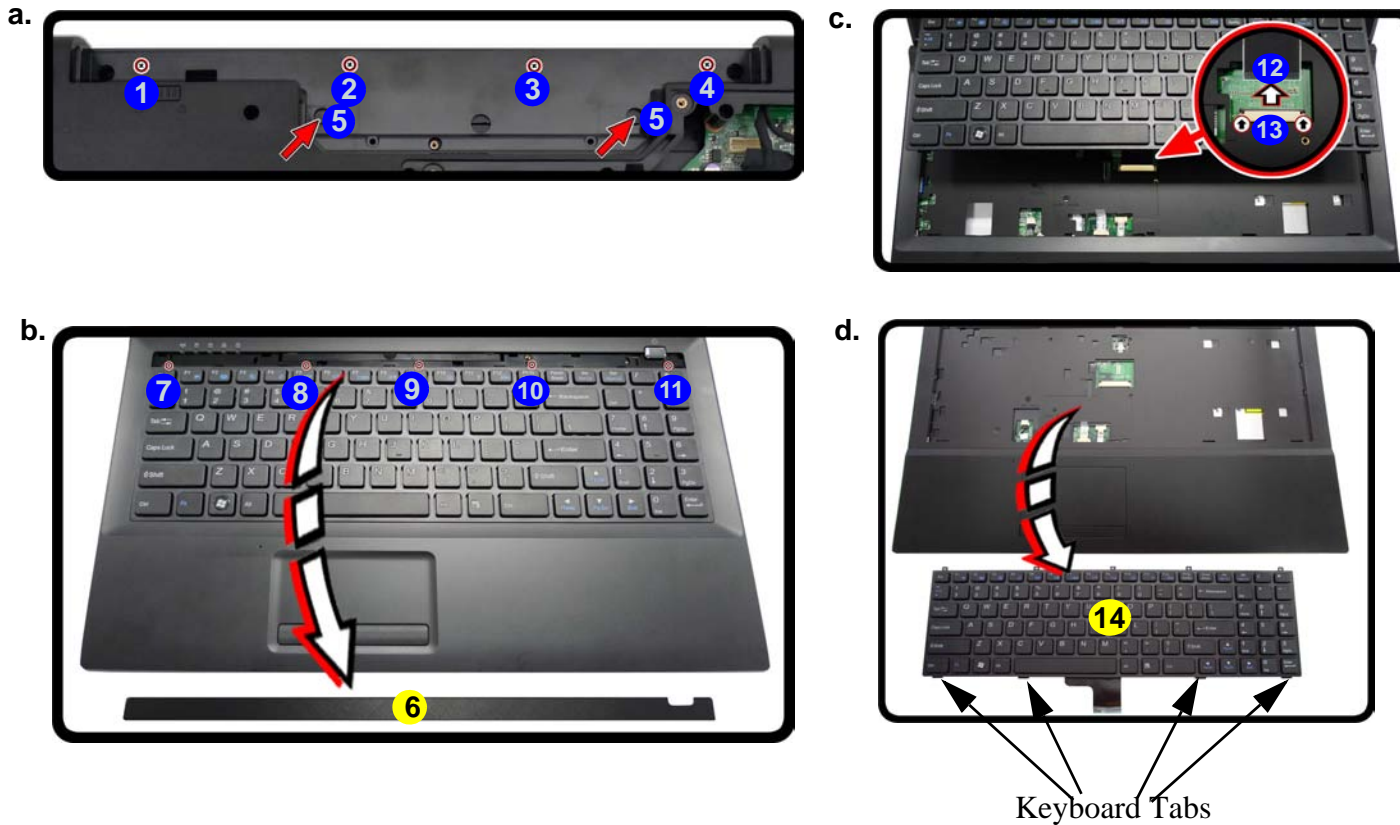

*Figure 10*  
**Keyboard Removal**

- a. Remove screws from the bottom of the computer. Press at points **5** to unsnap the LED cover module.
- b. Remove the LED cover module and screws from the keyboard.
- c. Carefully lift the keyboard up and disconnect the keyboard ribbon cable from the locking collar socket.
- d. Remove the keyboard.

  
**Re-Inserting the Keyboard**  
When re-inserting the keyboard firstly align the **four** keyboard tabs at the bottom ([Figure 10c](#)) at the bottom of the keyboard with the slots in the case.

  
6. LED Cover Module  
14. Keyboard  
• 9 Screws





---

# Appendix A:Part Lists

This appendix breaks down the *W250HU/W250HUQ/W251HUQ-C/W252HUM/W252HUM-C/W255HU/W255HU-C/W255HUM/W255HUM-C/W258HUQ-C* series notebook's construction into a series of illustrations. The component part numbers are indicated in the tables opposite the drawings.

**Note:** This section indicates the *manufacturer's* part numbers. Your organization may use a different system, so be sure to cross-check any relevant documentation.

**Note:** Some assemblies may have parts in common (especially screws). However, the part lists DO NOT indicate the total number of duplicated parts used.

**Note:** Be sure to check any update notices. The parts shown in these illustrations are appropriate for the system at the time of publication. Over the product life, some parts may be improved or re-configured, resulting in *new* part numbers.

## Part List Illustration Location

The following table indicates where to find the appropriate part list illustration.

*Table A - 1*  
Part List Illustration  
Location

Part	W251HUQ-C/W252HUM/ W252HUM-C/W255HU/ W255HU-C/W255HUM/ W255HUM-C	W258HUQ-C
Top	<i>page A - 3</i>	<i>page A - 4</i>
Bottom	<i>page A - 5</i>	
Combo	<i>page A - 6</i>	
DVD Dual Drive	<i>page A - 7</i>	
LCD (W25XHUQ)	<i>page A - 8</i>	
LCD (W25XHUM)	<i>page A - 9</i>	

# Top (W251HU/W252HU/W255HU SERIES)

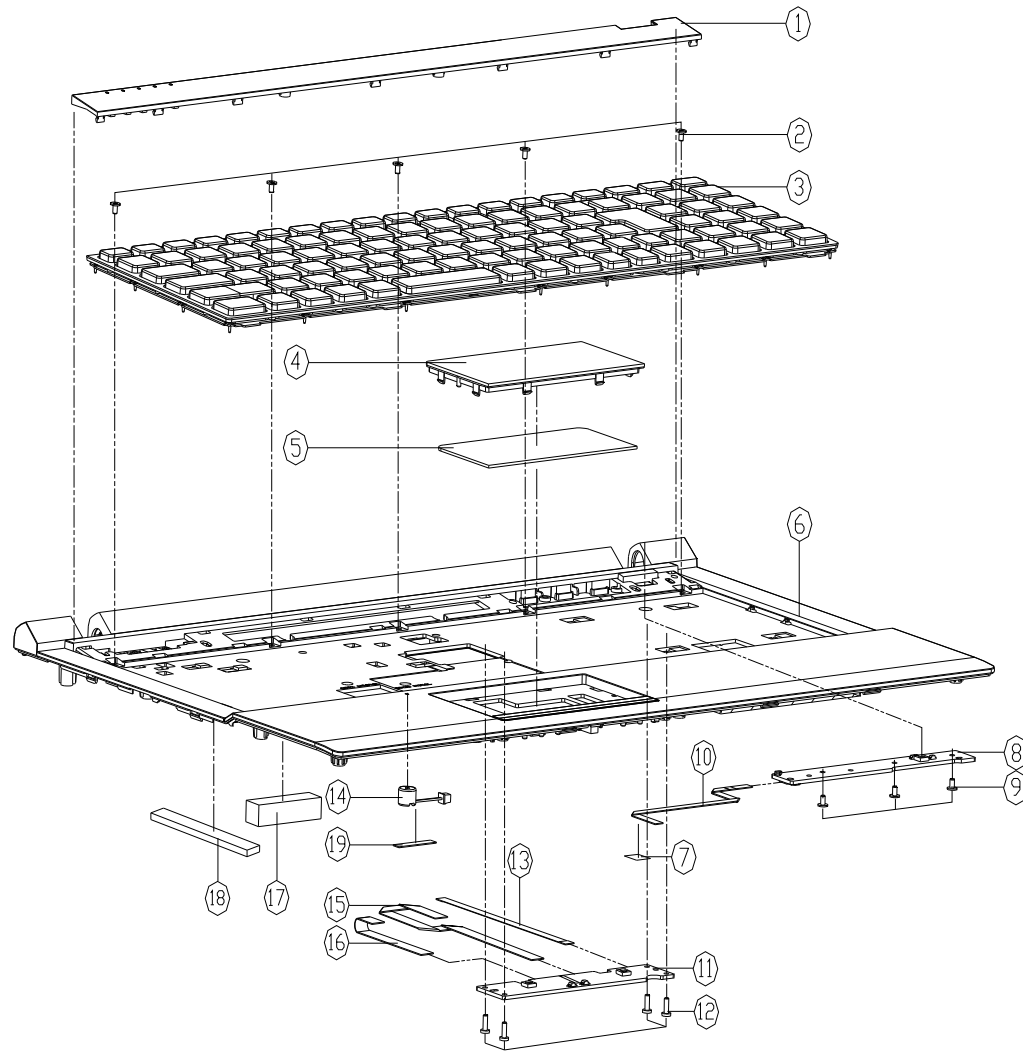

Figure A - 1  
Top (W251HU/  
W252HU/W255HU  
SERIES)

ITEM	PART NAME	PART NO	REMARK
1	KB COVER MODULE E5125	6-42-E5158-101	
2	SCREW M2x2.5L KI BK/Z ICT NY#35 T=03	6-35-B6120-2R/B	
3	KEY SWITCH/MECHANICAL KEYBOARD MODULE (E5125) (E5125)	6-79-E512000K-101	
4	CLICK BUTTON PLATE (PC/ABS) E5125	6-42-E5152-062	
5	TOUCH PAD SYNAPTICS IN-HUB-803 MULTI-ESTORE C400	6-49-C4802-010	
6	TOP CASE MODULE E5125	6-39-E5152-012	
6	TOP CASE MODULE E5125-C	6-39-E5152-012-C	
7	TOP FFC MYLAR (PET+3M 467) E51200	6-40-E5102-080	
8	POWER SWITCH BOARD V2.0 E51200	6-77-E5105-D02	
9	FFC CABLE FOR MB TO POWER BOARD 6PIN E51200	6-35-B1120-3RE	
10	CLICK BOARD V1.0 W250BU00	6-43-E5100-021	
11	CLICK BOARD V1.0 W250BU00	6-77-W2402-D01-A	
12	SCREW M2xSL K11T=08 D=40: BK/Z ICT NY	6-35-B6120-5R0	
13	FFC CABLE FOR MB TO CLICK BOARD 4PIN E51200	6-43-E5100-010	
14	FFC CABLE FOR MB TO TOUCH PAD 6PIN E51200	6-23-EMS4G-012	
15	FFC MB TO CLICK LED 6PIN C55000	6-43-C5500-010	
16	FFC CABLE FOR TOUCH PAD 6PIN C4500	6-43-C4502-010	
17	FFC SPRING FOR TOP CASE (S7462) (S7462) 6000 E51200	6-47-0019A-353	
18	SPONGE FOR TOP CASE (S7462) (S7462) 6000 E51200	6-47-0019A-570	
19	TAPE MYLAR (B) MYLAR M550J	6-40-M55J2-020	ONLY FOR E51250-C

A.Part Lists

## Top (W258HU SERIES)

Figure A - 1  
Top (W258HU SE-  
RIES)

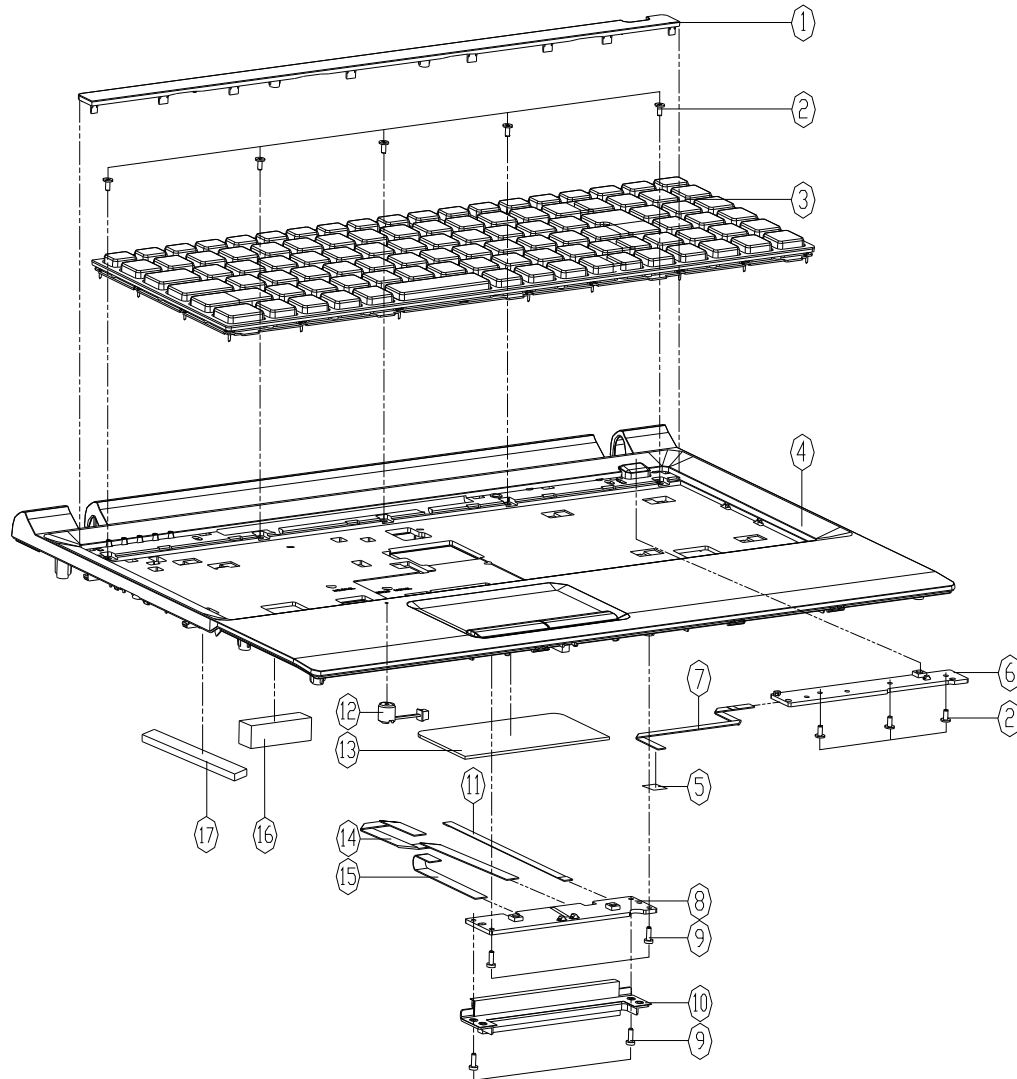

ITEM	PART NAME	PART NO	REMARK
1	KB COVER PC+ABS(CM6140) E51280	6-42-E5182-011	
2	(#H#P#B#S#E#Y#M#L#K#I#N#I#C#I#G#Y#P#A#T#C#H	6-35-B1120-3RE	
3	K/B US#BLACK#N#FR#M#C#S#M#D#L#E#S#I#2#8#0	6-79-E51200K-010	
4	TOP CASE MODULE C51280-C (CHANGE SPONGE)	6-39-E5182-012-C	
5	TOP FFC MYLAR (PET+3M 467) E51200	6-40-E5102-080	
6	POWER SWITCH BOARD V2.0 E51280	6-77-E518S-D02	
7	FFC CABLE FOR MB TO POWER BOARD 8PIN C51200	6-43-E5100-021	
8	CLICK BOARD V1.0 W250BUQ	6-77-W2402-D01-A	
9	(#H#P#B#S#E#Y#M#L#K#I#N#I#C#I#G#Y#P#A#T#C#H	6-35-C6120-4RB	
10	TP BRACKET MODULE E51280	6-33-E5182-100	
11	FFC CABLE FOR MB TO CLICK BOARD 4PIN C51200	6-43-E5100-010	
12	ME#S#P#O#S#E#F#E#R#H#2#M#2#2#W#O#L#D#E#S#E#L#E#M#M#S#E#	6-23-EM54G-012	
13	TOUCH PAD SYNAPSES TM-H146-003 MULTI-ESTURE C4800	6-49-C4802-010	
14	FFC MB TO CLICK LED 6PIN C55000	6-43-C5500-010	
15	FFC CABLE FOR TOUCH PAD 6PIN C4500	6-43-C4502-010	
16	FAN SPONGE FOR TOP C565(C25) C065(C04) C400 C5200	6-47-0019A-353	
17	SPONGE FOR TOP CASE C570(C2) C065(C04) C400	6-47-0019A-570	

# Bottom

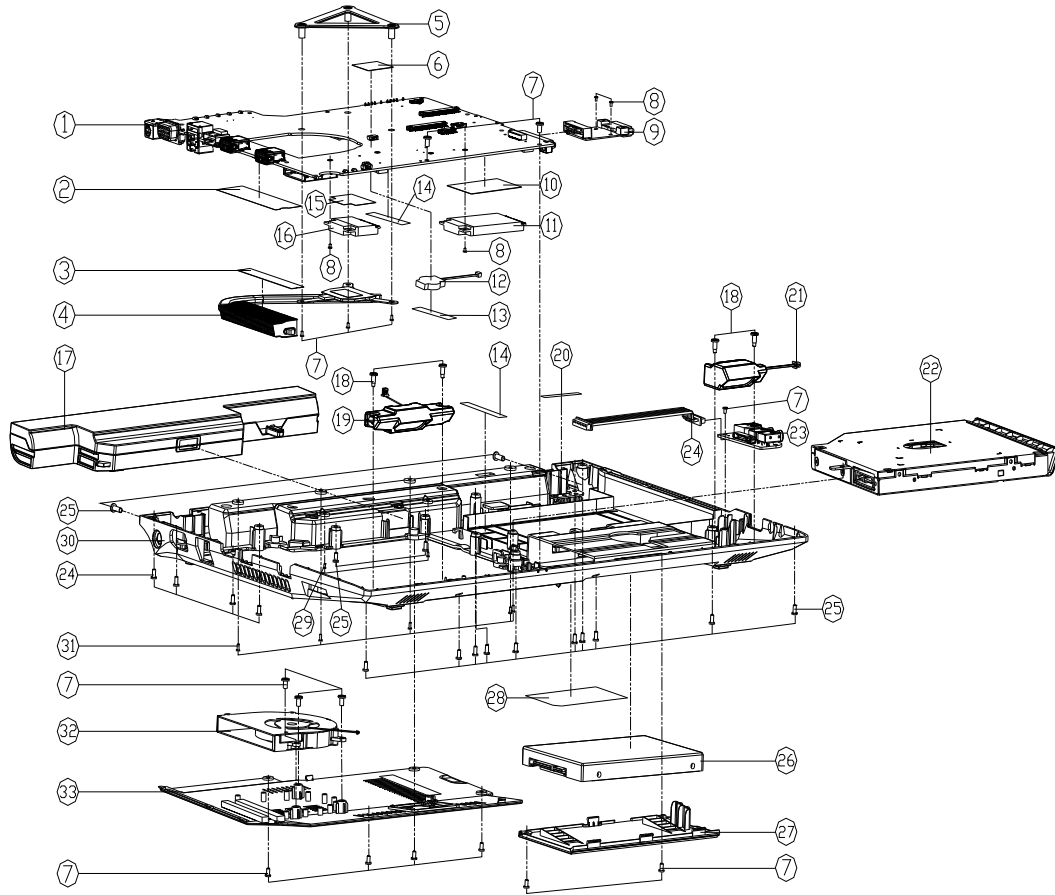

ITEM	PART NAME	PART NO	REMARK
1	MAIN BOARD V20 QV3G ; LCD 30P W25H0D	6-77-W25H0-D02	
1	MAIN BOARD V20 QV3G ; LCD 30P W25H0D	6-77-W25H0-D02-1	
1	MAIN BOARD V20 QV3G ; LCD 40P W25H0D	6-77-W25H0-D02-2	
1	MAIN BOARD V20 QV3G ; LCD 40P W25H0D	6-77-W25H0-D02-3	
2	MYLAR FOR M/B FIN C4500	6-40-C450S-010	
3	AIRDUCT MYLAR DFR117 W240HU	6-40-W24H8-010	
4	CPU HEATSINK MODULE W240HU	6-31-W24HN-100	
5	CPU SUPPORTER FOR HARD RIVER SEC W150HM	6-33-W150S-011	
6	AUDIO BOARD W/30 C4500S1 (CPU/PC/10W AC/CEM)	6-40-C450S-030	
7	SCREW M2.5xSL K1 BK/Z ICT NY	6-35-B612S-5RA	
8	SCREW M2xSL K1 RZ ICT NY (C08-4531-04)	6-35-B6120-3RD	
9	ODD BRIDGE BOARD VIA ES1200 (CN VLD)	6-77-E510N-D01	
10	MYLAR 40x50x11 (CR83 + 3M-467) M7351	6-40-M7351-020	ONLY FOR W/3G
11	MYLAR 40x50x11 (CR83) M7351	6-88-W150W-9100	(OPTION)
12	TAPE MYLAR (A) MYLAR M550J	6-23-2201S-P00	
13	TAPE MYLAR (A) MYLAR M550J	6-40-M55J2-010	
14	TAPE MYLAR (C) MYLAR M550J	6-40-M55J2-030	
15	3G HALF CARD MYLAR (PC/10W) E400	6-40-E412S-010	
16	MYLAR 40x50x11 (CR83) M7351	6-88-W76C2-7001	(OPTION)
16	MYLAR 40x50x11 (CR83) M7351	6-88-E4192-5300	(OPTION)
16	MYLAR 40x50x11 (CR83) M7351	6-88-C555F-7001	(OPTION)
16	MYLAR 40x50x11 (CR83) M7351	6-88-C555F-5300	(OPTION)
16	MYLAR 40x50x11 (CR83) M7351	6-88-W76C2-8702	(OPTION)
16	MYLAR 40x50x11 (CR83) M7351	6-88-W77C2-4200	(OPTION)
16	MYLAR 40x50x11 (CR83) M7351	6-88-W76C2-7001	(OPTION)
17	W/O DVD SUPER MULTI ASSY (OPTION)	6-87-C480S-4P42	(OPTION)
17	W/O DVD SUPER MULTI ASSY (OPTION)	6-87-E412S-4D7	(OPTION)
17	W/O DVD SUPER MULTI ASSY (OPTION)	6-87-C550S-4YF	(OPTION)
18	SCREW M2x6.2L NI ICT NY FOR SPEAKER	6-35-Z1120-6R2	
19	SPEAKER (L/R) 4W 8 OHM 20W 200HZ	6-23-5E510-011	
20	TAPE MYLAR (C) MYLAR M550J	6-40-M55J2-020	
21	SPEAKER (L/R) 4W 8 OHM 20W 200HZ	6-23-5E510-021	
22	SATA DVD SUPER MULTI ASSY (OPTION)	6-79-W25H0D-010	
22	SATA DVD SUPER MULTI ASSY (OPTION)	6-79-E512000-040	
22	SATA BLU-RAY COMBO ASSY E51200	6-79-W25H0D-000	
22	W/O ODD ASSY E51200	6-79-E51200Z-000	
23	AUDIO BOARD V3.0 C4500	6-77-C4508-D03	
24	VIA CABLE (P/P) NY TO AUDIO BOARD AND MYLAR (VLD)	6-43-E5100-031	
25	SCREW M2.5xSL K1 BK/Z NY ICT	6-35-B612S-8R0	
26	W/O HDD ASSY E51200	6-79-C480000J-010	
26	W/HDD ASSY E51200	6-79-E51200J-020	
27	HDD COVER (PC+ABS) E51200	6-42-E51QJ-011	
28	PRODUCT LABEL FOR W25H0D	6-45-W25H0D3-010	
28	PRODUCT LABEL FOR W25H0M	6-45-W25H0M3-010	
28	PRODUCT LABEL FOR W25SHU	6-45-W25SHU3-010	
28	PRODUCT LABEL FOR W25SHM	6-45-W25SHM3-010	
28	PRODUCT LABEL FOR W25H0D	6-45-W25H0D3-010	
29	SCREW M2xSL K11-08 (H-4D) BK/Z ICT NY	6-35-C2120-3R0	
30	BOTTOM CASE MODULE E51200	6-39-E5103-012	
30	BOTTOM CASE MODULE E51200-C	6-39-E5103-012-C	
31	SCREW M2xSL K11-08 (H-4D) BK/Z ICT NY	6-35-B6120-5R0	
32	CPU COVER MODULE W/3G E51200	6-42-AC450-013	
33	CPU COVER MODULE W/O 3G E51200	6-42-E5103-102	
33	CPU COVER MODULE W/O 3G E51200	6-42-E5103-202	

Figure A - 2  
Bottom

# Combo

Figure 3  
Combo

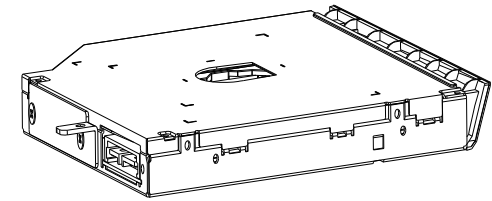
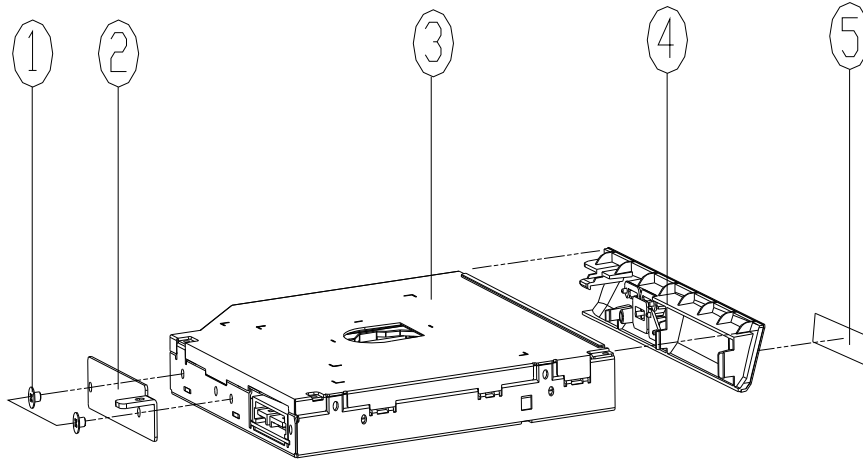

ITEM	PART NAME	PART NO	REMARK
1	六角自攻螺钉 M2x3L KI NI ICT GTY-PATCH	6-35-B1120-3RE	
2	CD ROM BRACKET SECC 镀锌 M740S	6-33-W74SZ-012-1	
3	蓝光DVD组合式托盘盖(带碟片槽) 适用于松下(PANASONIC)	6-85-B076X-P10	FOR PANASONIC
3	蓝光DVD组合式托盘盖(带碟片槽) 适用于日立(HITACHI)	6-85-B076X-511	FOR HLDS
4	ODD BEZEL MODULE E5120Q	6-42-E51QZ-102	
5	BLU-RAY ODD BEZEL LABEL (SIZE CHANGE) W860CU	6-45-W860W-011	

# DVD

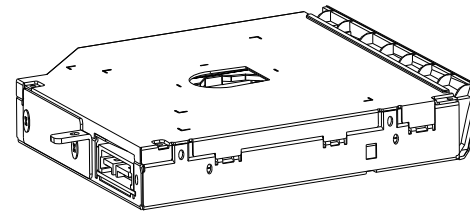
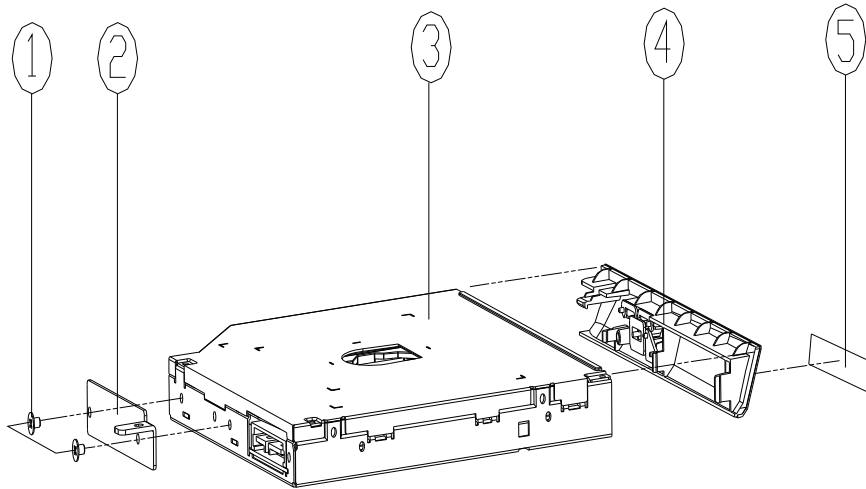
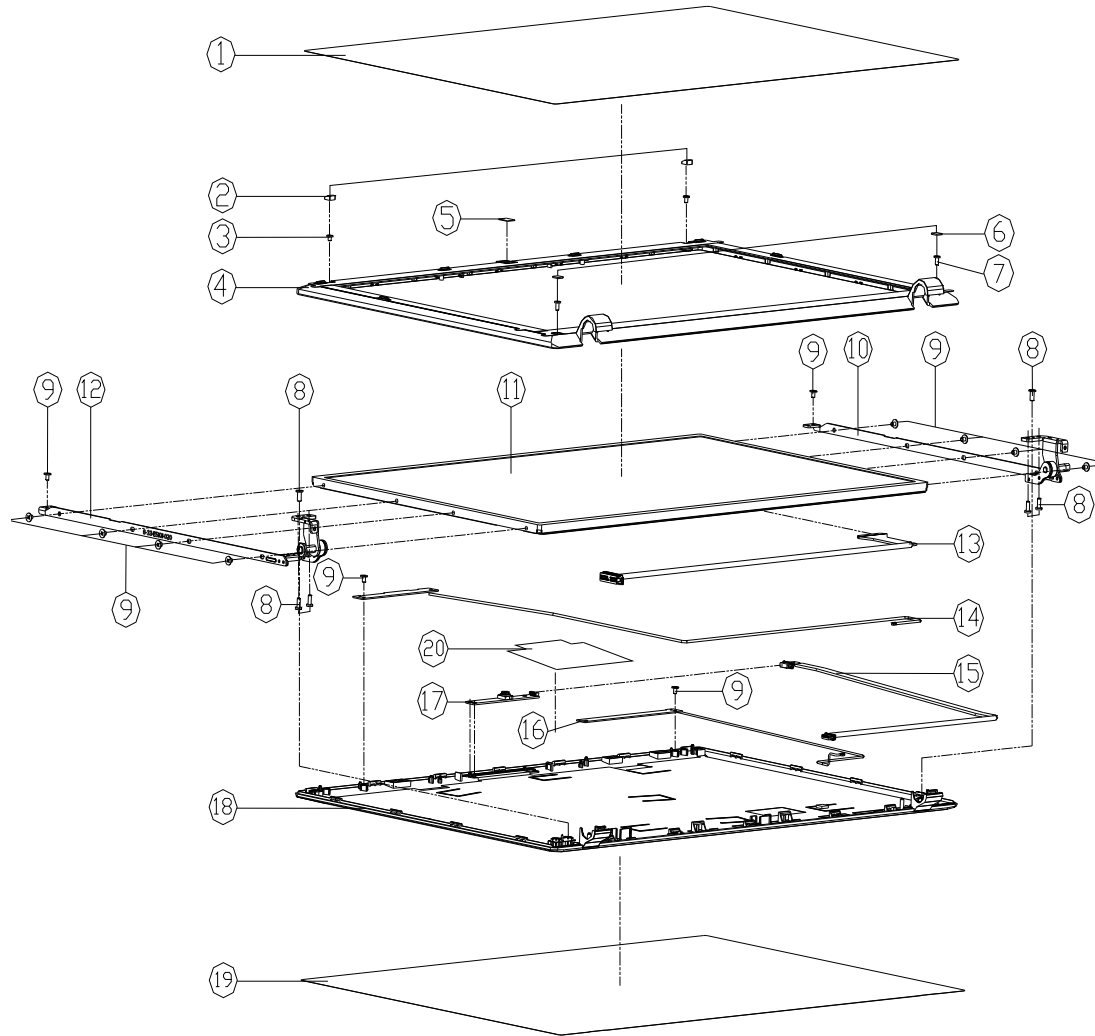

Figure A - 4  
DVD

ITEM	PART NAME	PART NO	REMARK
1	SCREW M2*3L K1 NI ICT GY-PATCH	6-35-B1120-3RE	
2	CD ROM BRACKET SECC G鉄 M740S	6-33-M74SZ-012-1	
3	DATA DVD SUPER MULTI 5 VPP BY 12MM 45MM FOR VCR 3.0W LANDING / SUPPORT HLDS	6-85-A078X-507	FOR HLDS
3	DATA DVD SUPER MULTI 5 VPP BY 12MM 45MM FOR VCR 3.0W LANDING / SUPPORT TSST	6-85-A078X-T09	FOR TSST
4	ODD BEZEL MODULE E5120Q	6-42-E51QZ-102	
5	SUPER MULTI ODD BEZEL LABEL (SIZE CHANGE)	6-45-W860Q-011	

# LCD (W25X HUQ)

Figure A - 5  
LCD (W25X HUQ)



ITEM	PART NAME	PART NO	REMARK
1	LED FRONT COVER PROTECTION MYLAR (PET-30015) E5200	6-40-E5101-030	
2	LED FRONT COVER SCREW RUBBER SILICON E5200	6-47-E5108-011	
3	SCREW M2xL KI BZ ICT NY (OD=4.5,DT=0.4)	6-35-B6120-3RD	
4	LED FRONT COVER MODULE E51200 (CHANGE)	6-39-E5101-012	
5	CCD LENS PMMA E5120Q	6-42-E5101-030	
5	W/D CCD LENS PMMA E5120Q	6-42-E5101-040	
6	FRONT COVER MYLAR PC FOR SCREW E51200	6-40-E5108-011	
7	SCREW M2xL KI BK/Z ICT NY(0.35 L=0.4)	6-35-B6120-6RB	
8	SCREW M2.5xL 0.015(0.4MM) KI BK/Z ICT NY	6-35-B6125-5R0	
9	SCREW M2.5xL 0.015(0.4MM) KI NI ICT G1Y-PATCH	6-35-B1120-3RE	
10	LCD HINGE R SK7 E51200 (KSH-HER)	6-33-E5101-010	
11	LED 15.6" HD LG LP156V01E-TLRE (LED) S5M	6-50-L8155-L07	
11	LED 15.6" HD CHINEE V656H-L01 CLARE TYPE S5M (LED)	6-50-L8155-D03	
11	LED 15.6" HD+ LG LP156V01E-TLRE CLARE TYPE	6-50-LA157-L03	
12	LCD HINGE L SK7 E51200 (KSH-HER)	6-33-E5101-020	
13	WIRE CABLE FOR LVDS 29MM UL/PS (CONDUCTIVE) MHD E5200	6-43-E5101-011-B	FOR HD LCD ONLY
13	WIRE CABLE FOR LVDS 29MM UL/PS (CONDUCTIVE) W25HUQ	6-43-W25H1-010-A	ONLY FOR HD+ LCD
14	WIRE CABLE FOR LVDS 29MM UL/PS (NON-CONDUCTIVE) E5200	6-23-7E510-040	
15	WIRE CABLE FOR CCD SP 229MM (HD) E51200	6-43-E5101-011	
16	WIRE CABLE FOR CCD SP 229MM (HD) W25HUQ	6-23-7E510-011	
17	OVC CAMERA HOUSING FIX (BNC)6322-010 L3M 6AA E5200	6-88-E510C-4900	OPTION
17	OVC CAMERA HOUSING FIX (BNC)6322-010 L3M 6AA E5200	6-88-E510C-4901	OPTION
18	LCD BACK IHR COVER MODULE E51200-C	6-39-E5101-021-C	FOR W25HUQ-C / W25HUQ-E
18	BACK COVER MODULE E5125	6-39-E5151-021	FOR W25SHU
18	BACK COVER MODULE E5125-C	6-39-E5151-021-C	FOR W25SHU-C
18	LCD IHR BACK COVER MODULE E51200-C	6-39-E5181-021-C	FOR W25SHUQ-C
19	LED BACK COVER PROTECTION MYLAR (PET-30015) E5200	6-40-E5101-041	FOR W25HUQ-E / W25HUQ / W25SHUQ
19	LED BACK COVER PROTECTION MYLAR (PET-30015) E5200	6-40-B51M8-020	FOR W25SHU
20	CCD AL FOIL (AL FOIL MYLAR-011) W24HUQ	6-47-W24H1-010	ONLY FOR W25HUQ-C / W25SHUQ-E



# LCD (W25X HUM)

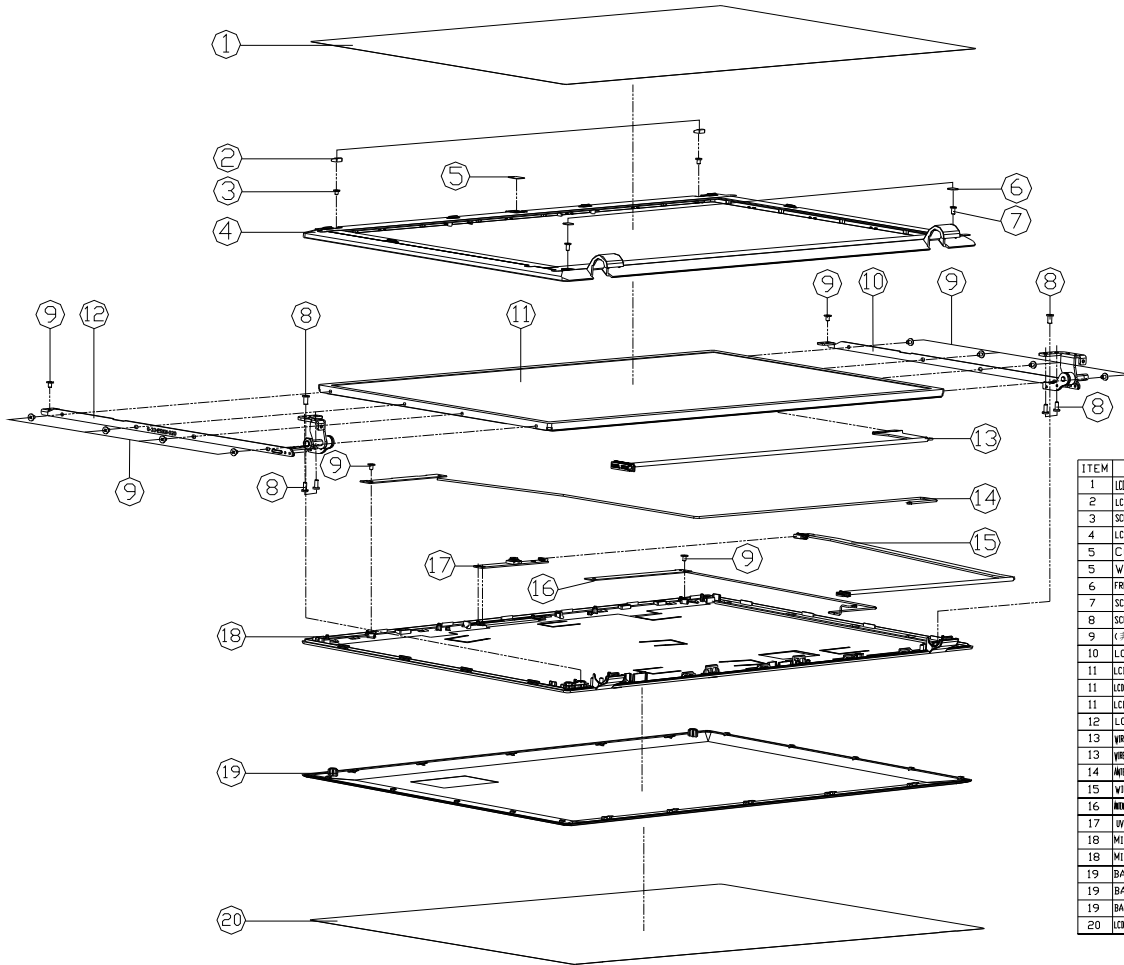

Figure A - 6  
LCD (W25X HUM)

ITEM	PART NAME	PART NO	REMARK
1	LCD FRONT COVER PROTECTION MYLAR (PET) 0.075(0.003) ES200	6-40-E5101-030	
2	LCD FRONT COVER SCREW RUBBER SILICON ES200	6-47-E5108-011	
3	SCREW M2x3, KI BZ ICT NY (CO) #45, DT 0.4	6-35-B6120-3RD	
4	LCD FRONT COVER MODULE ES1200 (CHANGE)	6-39-E5101-012	
5	CCD LENS PMMA ES1200	6-42-E5101-030	
5	W/O CCD LENS PMMA ES1200	6-42-E5101-040	
6	FRONT COVER MYLAR PC FOR SCREW ES1200	6-40-E5108-011	
7	SCREW M2x4, KI BK/Z ICT NY #35 (H04)	6-35-B6120-6RB	
8	SCREW M2.5xSL (0.01) 0.4MM KI BK/Z ICT NY	6-35-B6125-SRD	
9	ケーブル用 3SCREW M2x3, KI NI ICT GTY-PATCH	6-35-B1120-3RE	
10	LCD HINGE R SK7 ES1200 (CSINHER)	6-33-E5101-010	
11	LCD 15.6" HD LG LP156WH2-TL02 QLED S5MM	6-50-L8155-L07	
11	LCD 15.6" HD DM (NE) M5606-L08 GLARE TYPE S5MM (LED)	6-50-L8155-D03	
11	LCD 15.6" HD LG LP156WH1-TL02 GLARE TYPE	6-50-LA157-L03	
12	LCD HINGE L SK7 ES1200 (CSINHER)	6-33-E5101-020	
13	WIRE CABLE FOR LVDS 22PIN AL-PS (CONV) 64-40 ES1200	6-43-E5101-011-B	FOR HD LCD ONLY
13	WIRE CABLE FOR LVDS 22PIN AL-PS (CONV) 64-40 ES1200	6-43-W25A1-010-B	FOR HD LCD ONLY
14	MYLAR 36 PVC 36 PPS 0.075(0.003) 0.4MM (L) 85MM ES200	6-23-7E510-040	
15	WIRE CABLE FOR CCD SP 22PIN (AL) ES1200	6-43-E510T-011	
16	MYLAR 36 DM (NE) 0.075(0.003) 0.4MM (L) 85MM ES200	6-23-7E510-011	
17	WIRE CABLE FOR LVDS 22PIN AL-PS (CONV) 64-40 ES1200	6-88-E510C-4900	OPTION
18	MIDDLE COVER MODULE W25SHUM	6-39-W25U1-030	FOR W25SHUM W25SHUM
18	MIDDLE COVER (PC+ABS) W25SHUM	6-39-W25U1-03A	FOR W25SHUM-C
19	BACK COVER MODULE W25SHUM	6-39-W25H1-020	FOR W25SHUM W25SHUM-C
19	BACK COVER MODULE W25SHUM	6-39-W25U1-020	FOR W25SHUM W25SHUM-C
19	BACK COVER 7230P FOR MIFA W25SHUM	A6-39-W25U1-02A	FOR W25SHUM MIFA W25SHUM-C
20	LCD BACK COVER PROTECTION MYLAR (PET) 0.075(0.003) ES100	6-40-B51M8-020	ONLY FOR W25SHUM-C

A.Part Lists



# Appendix B: Schematic Diagrams

This appendix has circuit diagrams of the *W250HU/W250HUQ/W251HUQ-C/W252HUM/W252HUM-C/W255HU/W255HU-C/W255HUM/W255HUM-C/W258HUQ-C* notebook's PCB's. The following table indicates where to find the appropriate schematic diagram.

Diagram - Page	Diagram - Page	Diagram - Page
<i>System Block Diagram - Page B - 2</i>	<i>CougarPoint - M 6/9 - Page B - 19</i>	<i>Power 0.85VS - Page B - 36</i>
<i>CPU 1/7 (DMI, PEG, FDI) - Page B - 3</i>	<i>CougarPoint - M 7/9 - Page B - 20</i>	<i>Power V-Core1 - Page B - 37</i>
<i>CPU 2/7 (CLK, MISC, JTAG) - Page B - 4</i>	<i>CougarPoint - M 8/9 - Page B - 21</i>	<i>Power V-Core2 - Page B - 38</i>
<i>CPU 3/7 (DDR3) - Page B - 5</i>	<i>CougarPoint - M 9/9 - Page B - 22</i>	<i>Charger, DC In - Page B - 39</i>
<i>CPU 4/7 (Power) - Page B - 6</i>	<i>New Card, Mini PCIE - Page B - 23</i>	<i>Click Board - Page B - 40</i>
<i>CPU 5/7 (Graphics Power) - Page B - 7</i>	<i>CCD, 3G, TPM - Page B - 24</i>	<i>Audio Board/USB - Page B - 41</i>
<i>CPU 6/7 (GND) - Page B - 8</i>	<i>Card Reader/LAN JMC251C - Page B - 25</i>	<i>Power Switch &amp; LID Board - Page B - 42</i>
<i>CPU 7/7 (RESERVED) - Page B - 9</i>	<i>LAN (JMC251C), SATA HDD, ODD - Page B - 26</i>	<i>External ODD Board - Page B - 43</i>
<i>DDR3 SO-DIMM_0 - Page B - 10</i>	<i>USB 3.0 NEC, USB Charger - Page B - 27</i>	<i>Power Sequence - Page B - 44</i>
<i>DDR3 SO-DIMM_1 - Page B - 11</i>	<i>KBC-ITE IT8518 - Page B - 28</i>	
<i>LVDS, Inverter - Page B - 12</i>	<i>LED, MDC, BT - Page B - 29</i>	
<i>HDMI, CRT - Page B - 13</i>	<i>Audio Codec ALC269 - Page B - 30</i>	
<i>CougarPoint - M 1/9 - Page B - 14</i>	<i>USB, Fan, TP, Multi-Conn - Page B - 31</i>	
<i>CougarPoint - M 2/9 - Page B - 15</i>	<i>5VS, 3VS, 1.05VS, 1.5VS_CPU - Page B - 32</i>	
<i>CougarPoint - M 3/9 - Page B - 16</i>	<i>VDD3, VDD5 - Page B - 33</i>	
<i>CougarPoint - M 4/9 - Page B - 17</i>	<i>Power 1.5V/0.75V/1.8VS - Page B - 34</i>	
<i>CougarPoint - M 5/9 - Page B - 18</i>	<i>Power 1.05VS - Page B - 35</i>	

*Table B - 1*  
**SCHEMATIC  
DIAGRAMS**



### Version Note

The schematic diagrams in this chapter are based upon version 6-7P-W24H5-002. If your mainboard (or other boards) are a later version, please check with the Service Center for updated diagrams (if required).

# System Block Diagram

Sheet 1 of 43  
System Block  
Diagram

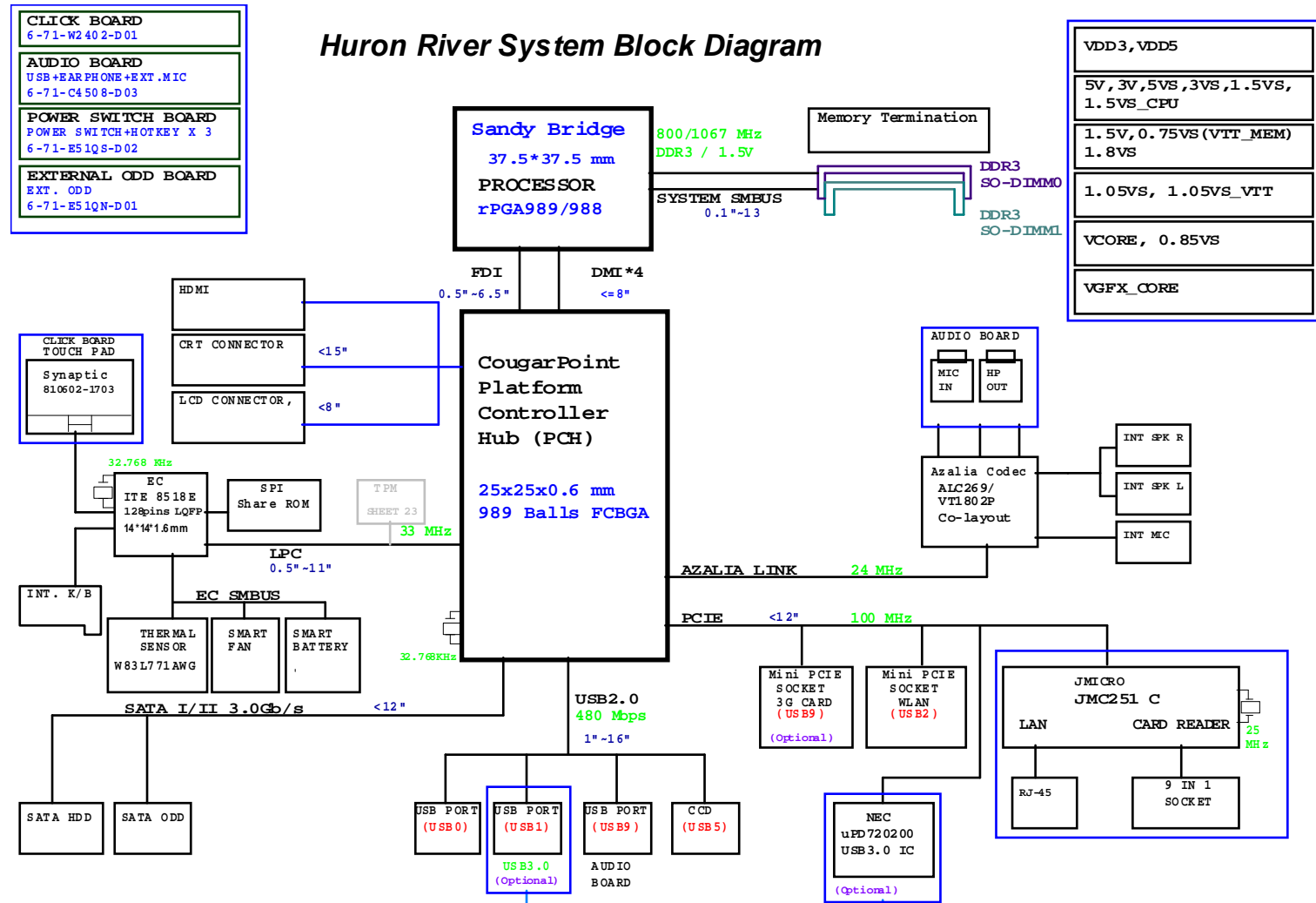

# CPU 1/7 (DMI, PEG, FDI)

## Sandy Bridge Processor 1/7 ( DMI, PEG, FDI )

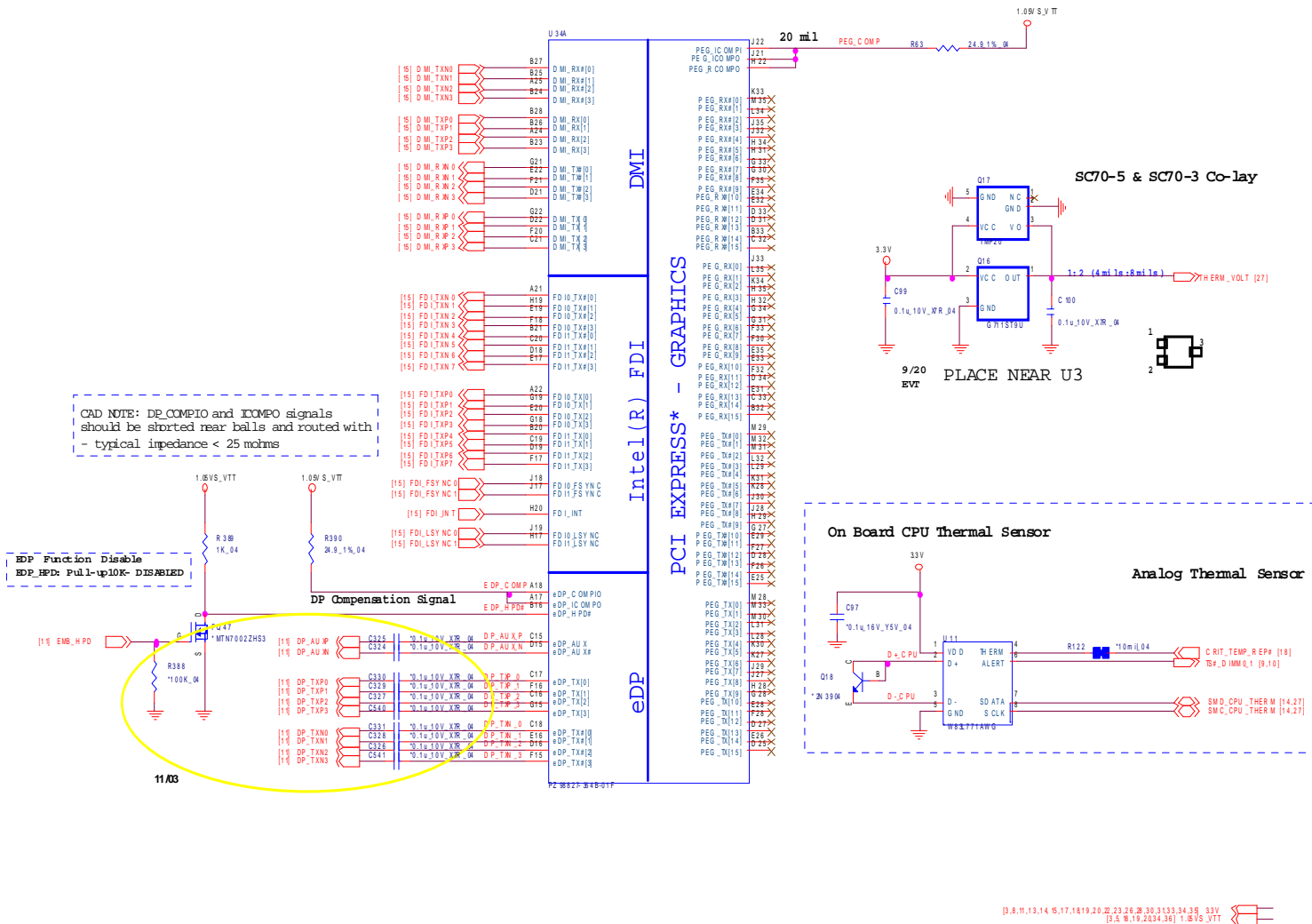

Sheet 2 of 43  
CPU 1/7  
(DMI, PEG, FDI)

B. Schematic Diagrams

# CPU 2/7 (CLK, MISC, JTAG)

Sheet 3 of 43  
CPU 2/7  
(CLK, MISC, JTAG)

## Sandy Bridge Processor 2/7 ( CLK, MISC, JTAG )

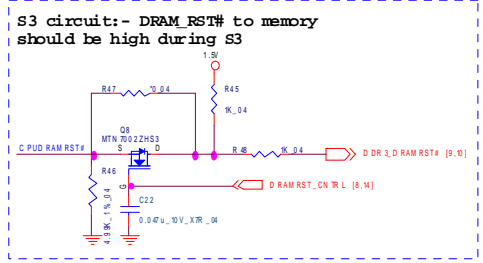
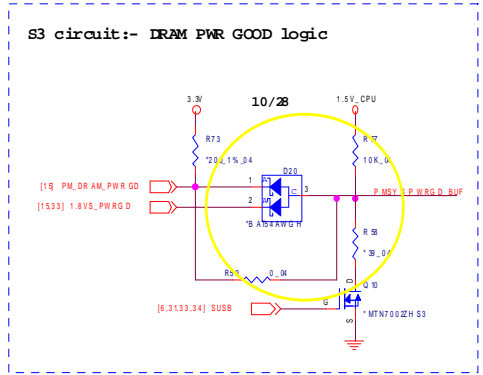
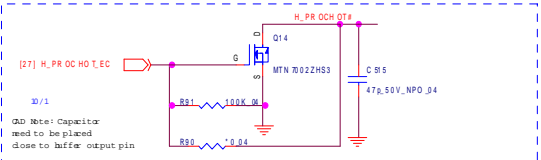
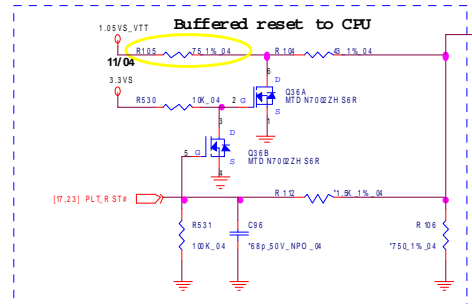
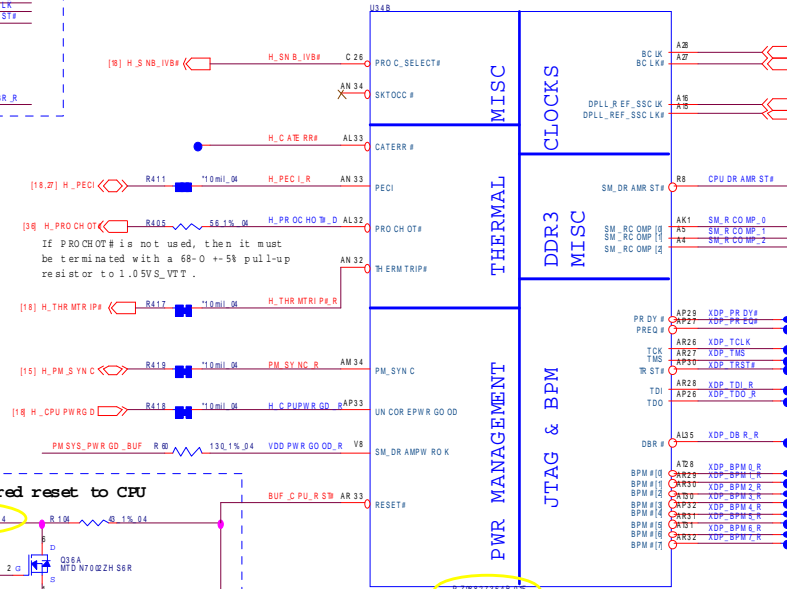
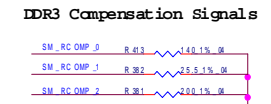
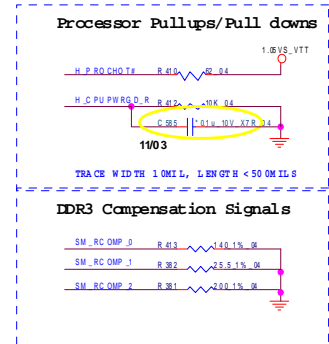
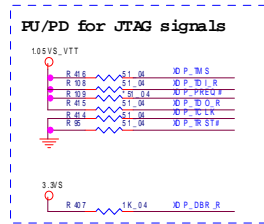

- [2,5,18,19,20,30,36] 1.05V\_VTT
- [6,31] 1.0V\_CPU
- [8,9,10,32,33,34,35,36] 3.3V
- [28,11,13,14,15,17,18,19,20,22,23,26,28,30,31,33,34,35] 3.3V
- [10,11,12,13,14,15,16,17,18,19,20,22,24,25,27,28,29,30,36] 3.3V/S

# CPU 3/7 (DDR3)

## Sandy Bridge Processor 3/7 ( DDR3 )

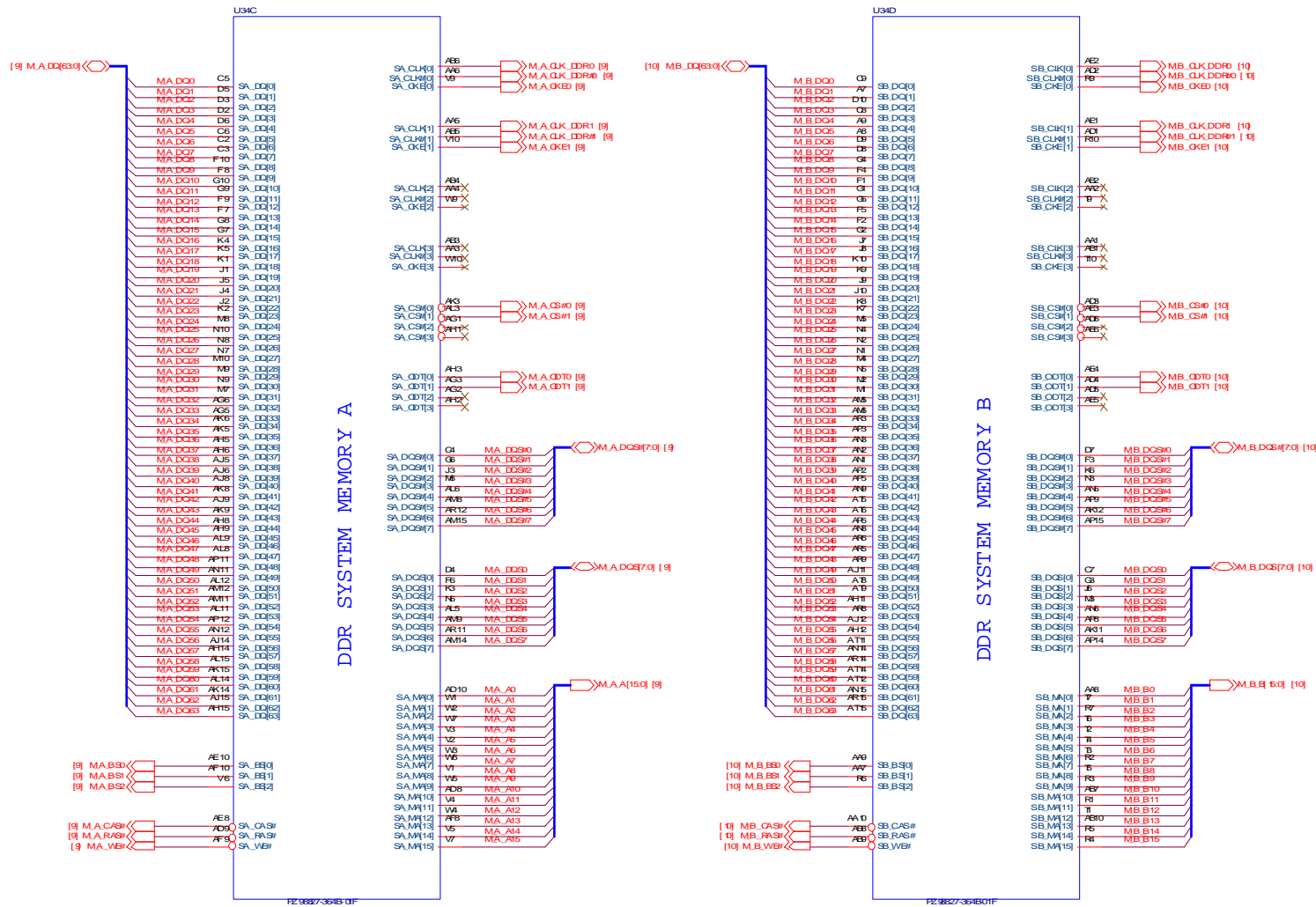

Sheet 4 of 43  
CPU 3/7  
(DDR3)

B. Schematic Diagrams

# CPU 4/7 (Power)

## Sandy Bridge Processor 4/7

Sheet 5 of 43  
CPU 4/7  
(Power)

**PROCESSOR CORE POWER**  
ICCMAX Maximum Processor SV 48

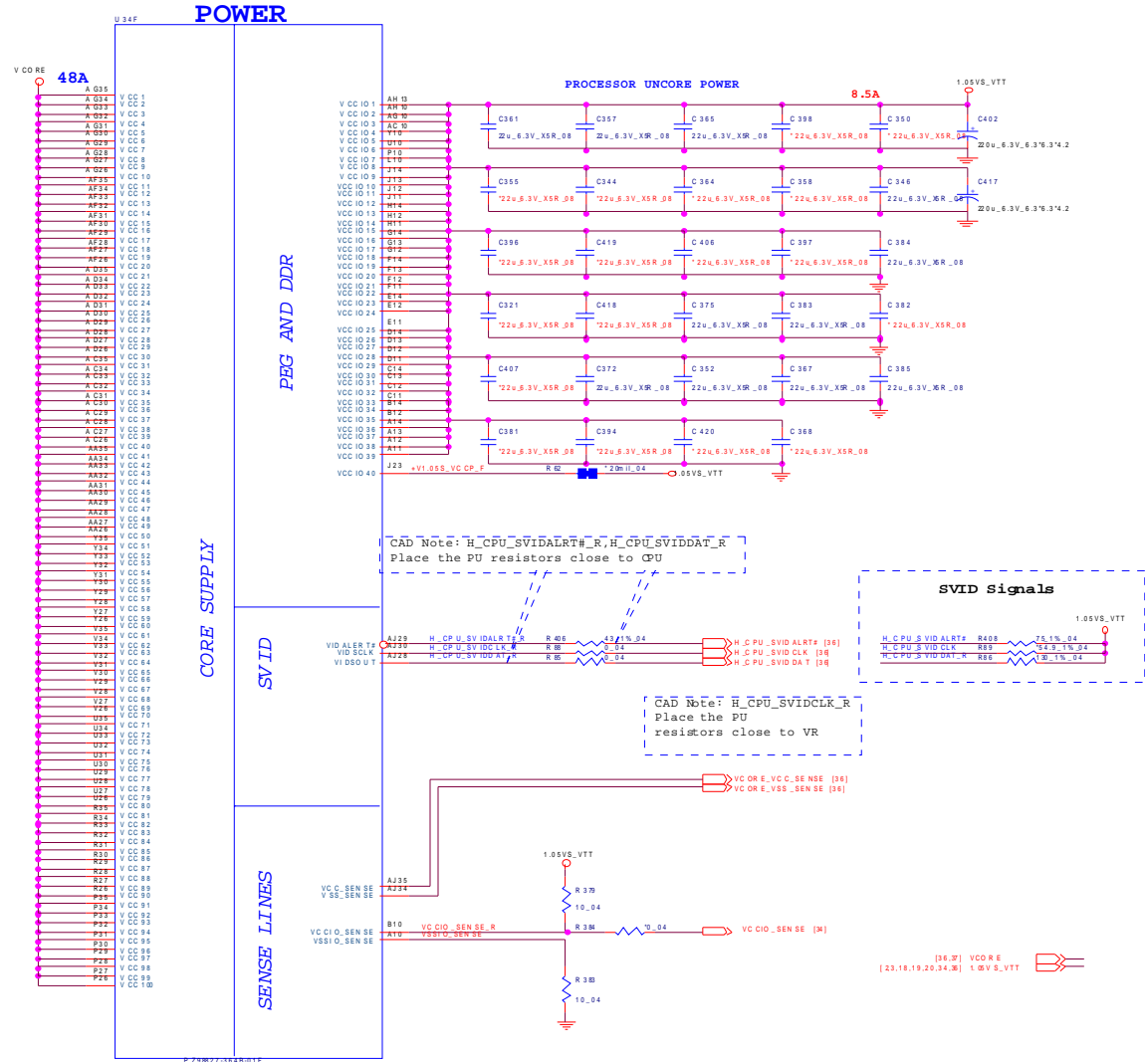
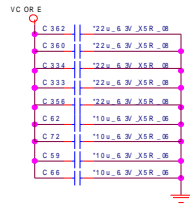
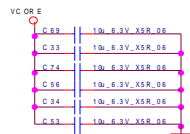
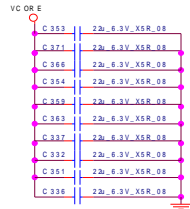



# CPU 5/7 (Graphics Power)

## Sandy Bridge Processor 5/7 ( GRAPHICS POWER )

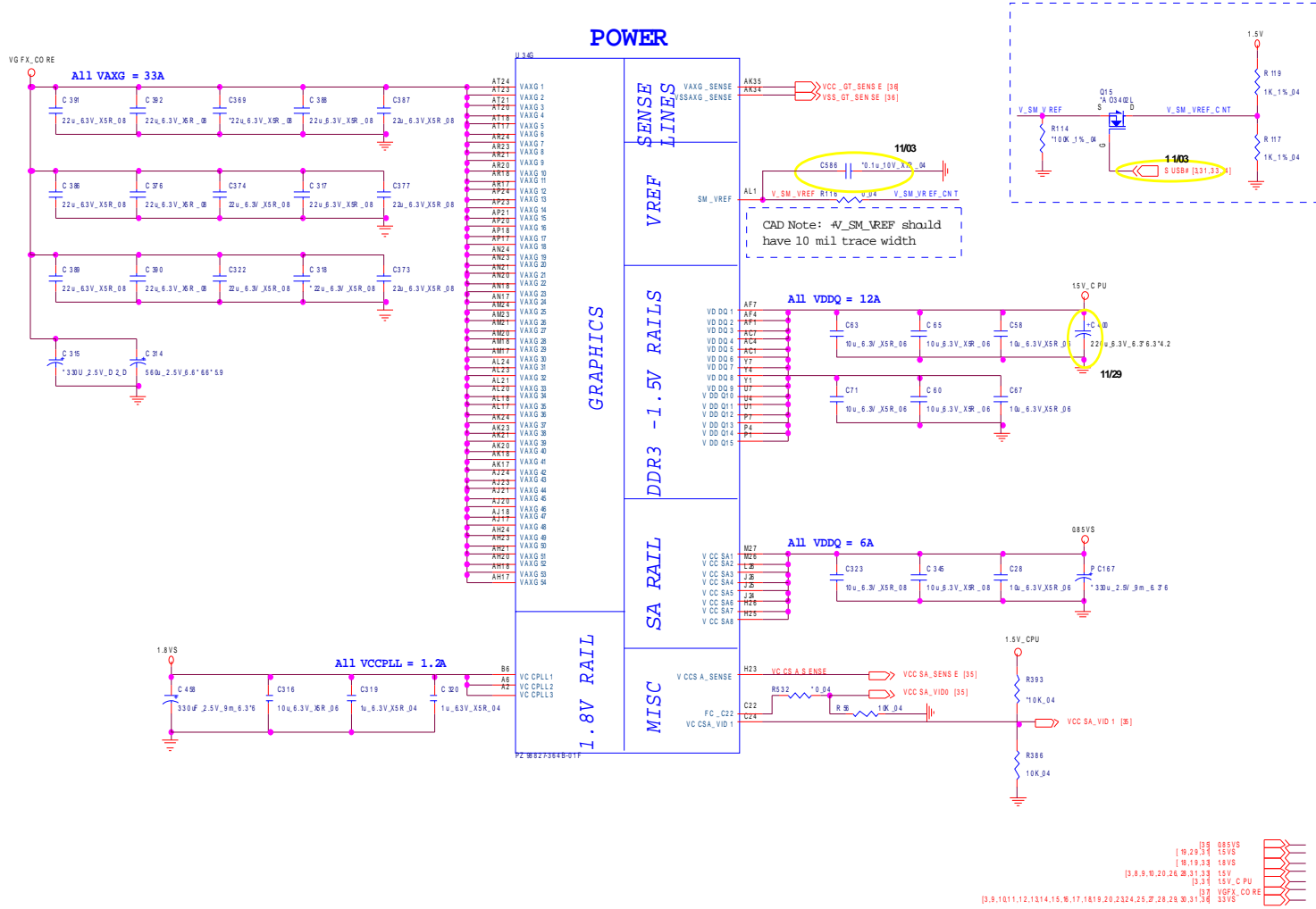

Sheet 6 of 43  
CPU 5/7  
(Graphics Power)

B. Schematic Diagrams

# CPU 6/7 (GND)

## Sandy Bridge Processor 6/7 ( GND )

Sheet 7 of 43  
CPU 6/7 (GND)

CAD Note: 0 ohm resistor should be placed close to CPU

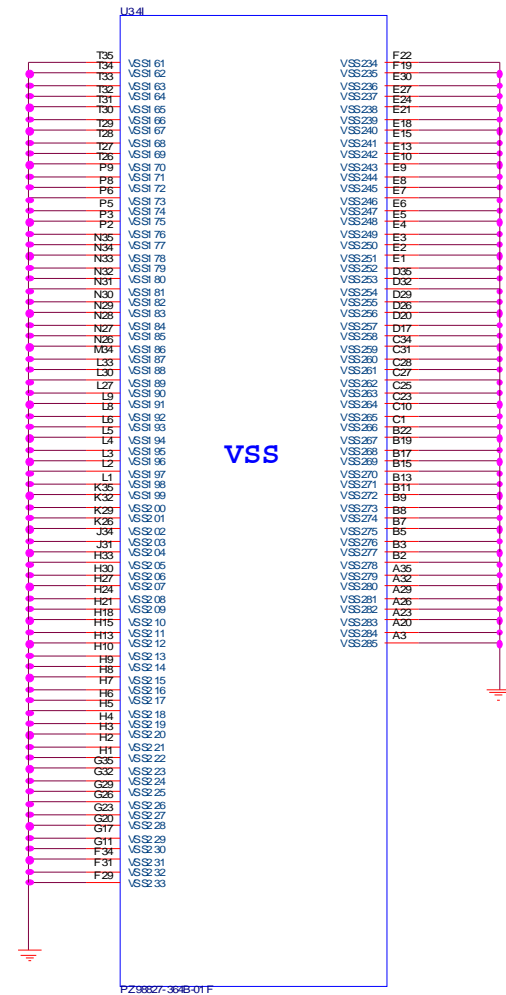
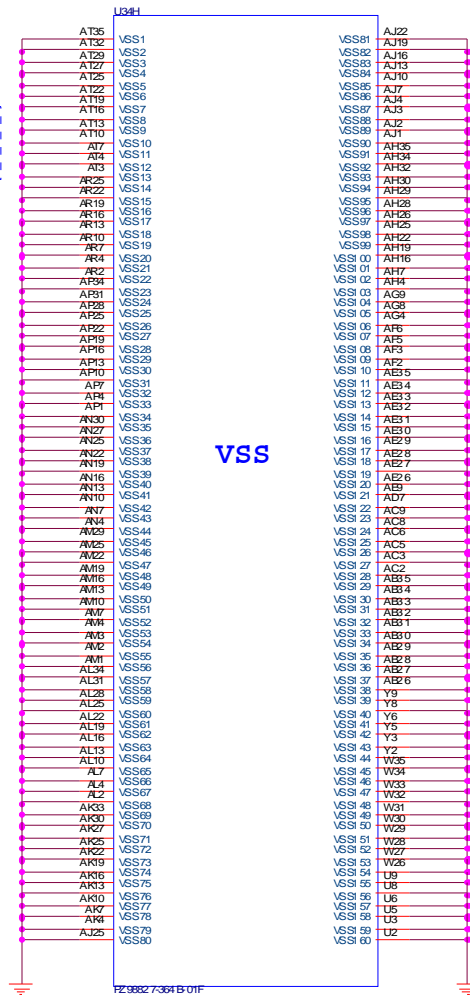

# CPU 7/7 (RESERVED)

## Sandy Bridge Processor 7/7 ( RESERVED )

**CFG Straps for Processor**

PEG Static Lane Reversal - CFG2 is for the 16x

CFG 2	1:(Default) Normal Operation; Lane # definition matches socket pin map definition 0:Lane Reversed
-------	--

**Display Port Presence Strap**

CFG 4	1:(Default) Disabled; No Physical Display Port attached to Embedded Display Port 0:Enabled; An external Display Port device is connected to the Embedded Display Port
-------	--

**PCIe Port Bifurcation Straps**

CFG [6 : 5]	11: (Default) x16 - Device 1 functions 1 and 2 disabled 10: x8, x8 - Device 1 function 1 enabled ; function 2 disabled 01: Reserved - (Device 1 function 1 disabled ; function 2 enabled) 00: x8, x4 x4 - Device 1 functions 1 and 2 enabled
-------------	---

**PEG DEFER TRAINING**

CFG 7	1: (Default) PEG Train immediately following xxRESETB de assertion 0: PEG Wait for BIOS for training
-------	---

On CRB  
H\_SNB\_IVBH\_PWCTRL = low, 1.0V  
H\_SNB\_IVBH\_PWCTRL = high/NC, 1.05V

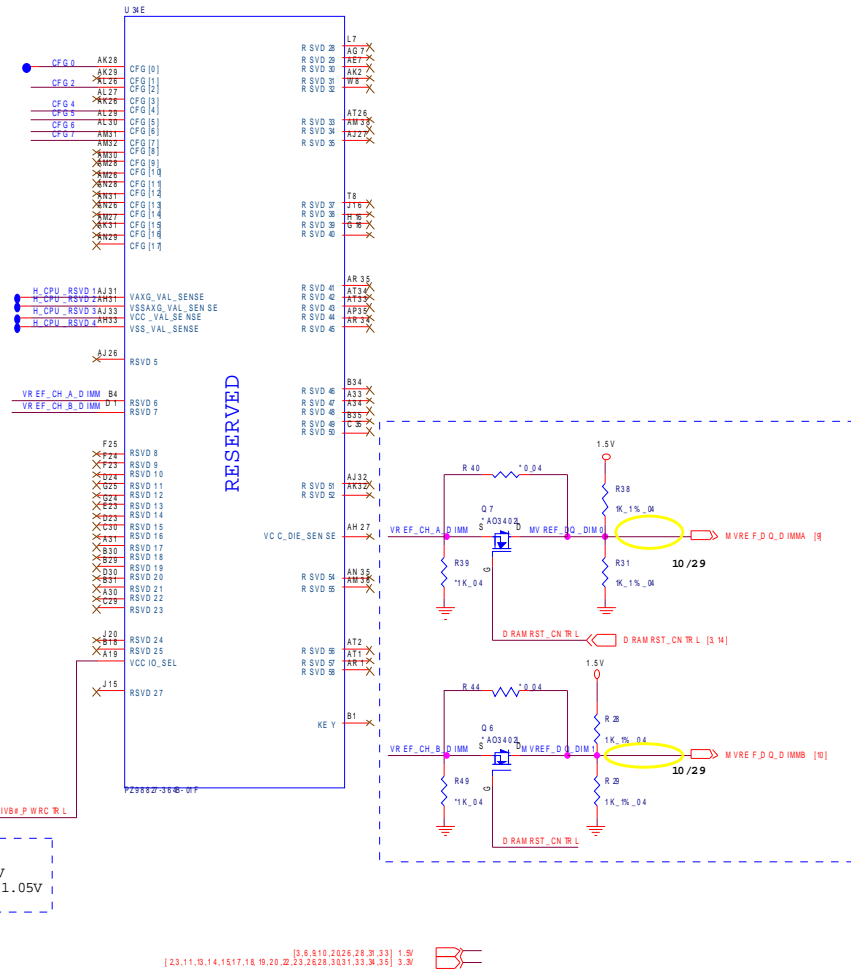

Sheet 8 of 43  
CPU 7/7  
(RESERVED)

B. Schematic Diagrams







# HDMI, CRT

## HDMI PORT

FOR INTEL GRAPHIC

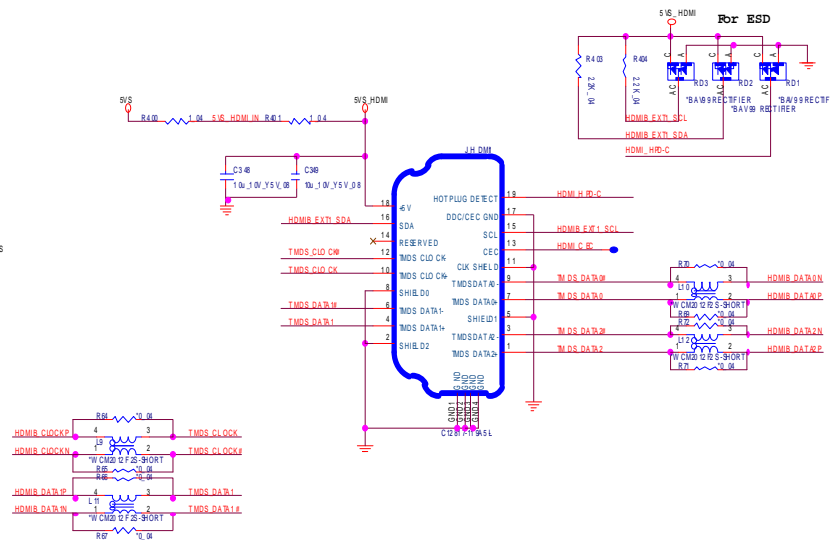
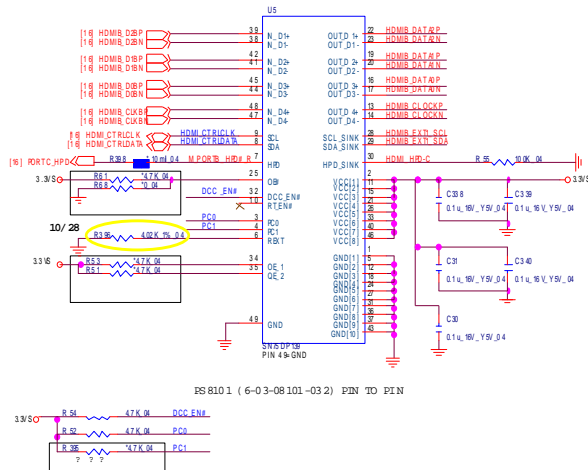

Sheet 12 of 43  
HDMI, CRT

B. Schematic Diagrams

## CRT PORT

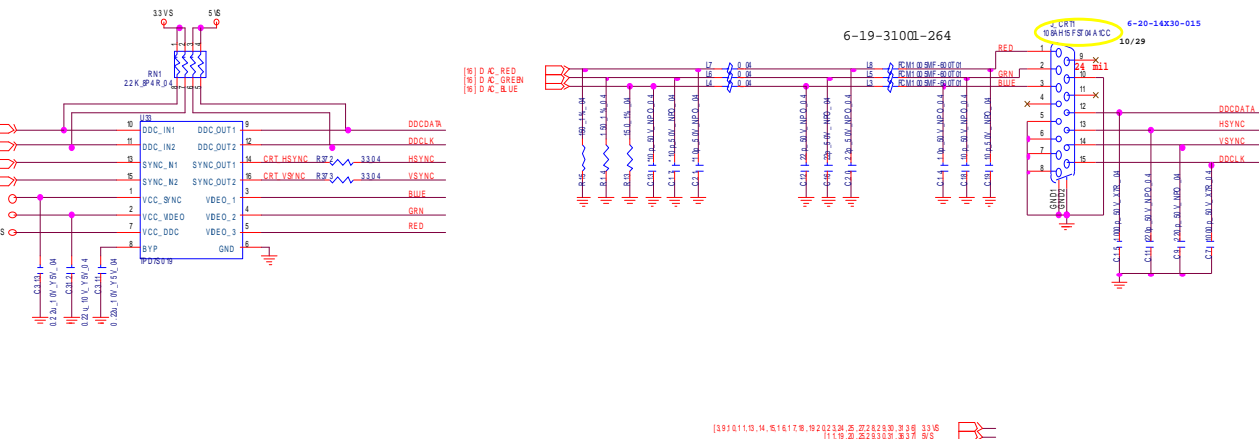







# CougarPoint - M 3/9

Sheet 15 of 43  
CougarPoint - M 3/9

## CougarPoint -M (DMI,FDI,GPIO)

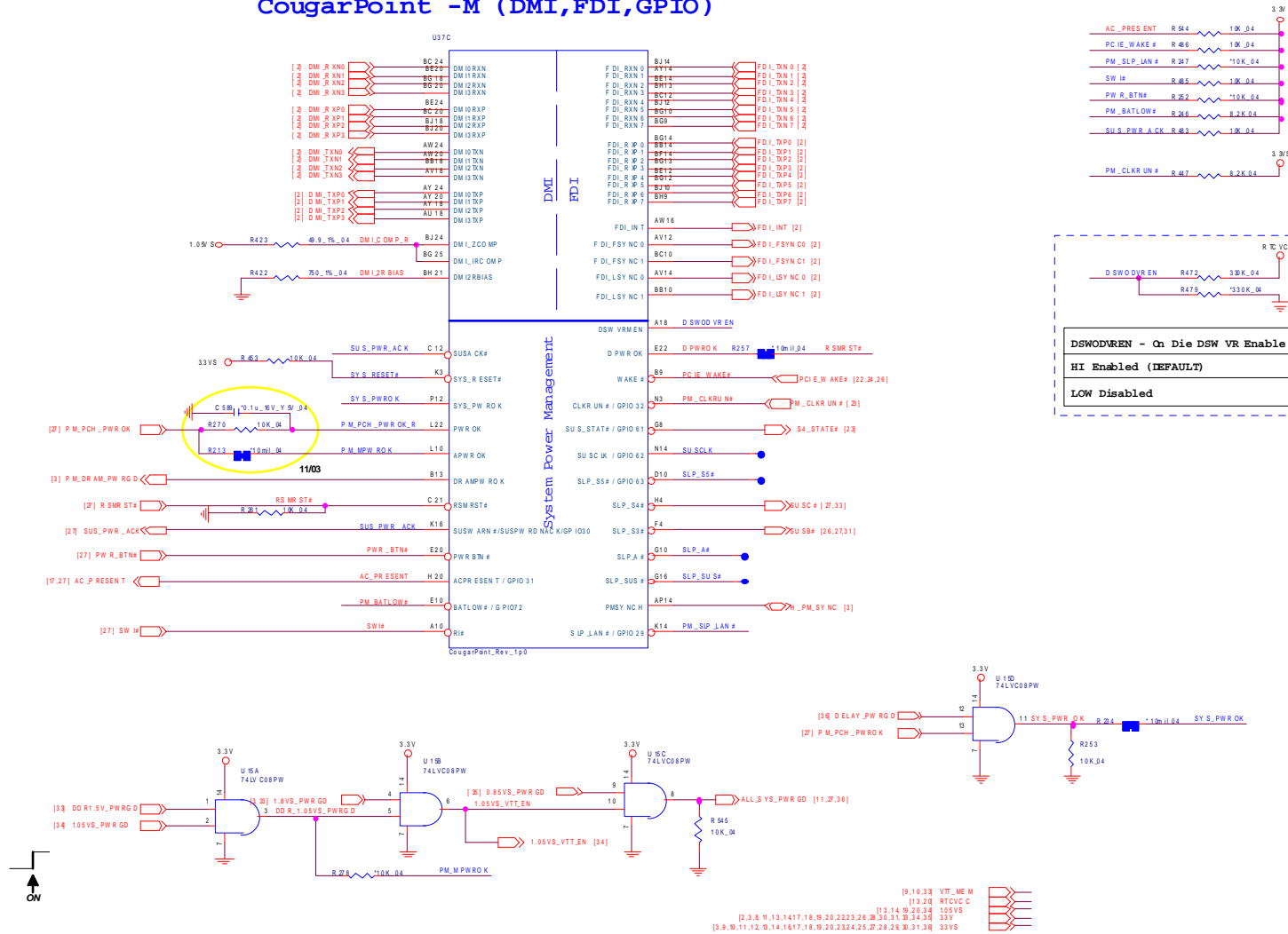

**DSWOD'REN - On Die DSW VR Enable**

**HI Enabled (DEFAULT)**

**LOW Disabled**

# CougarPoint - M 4/9

## CougarPoint - M (LVDS, DDI, CRT)

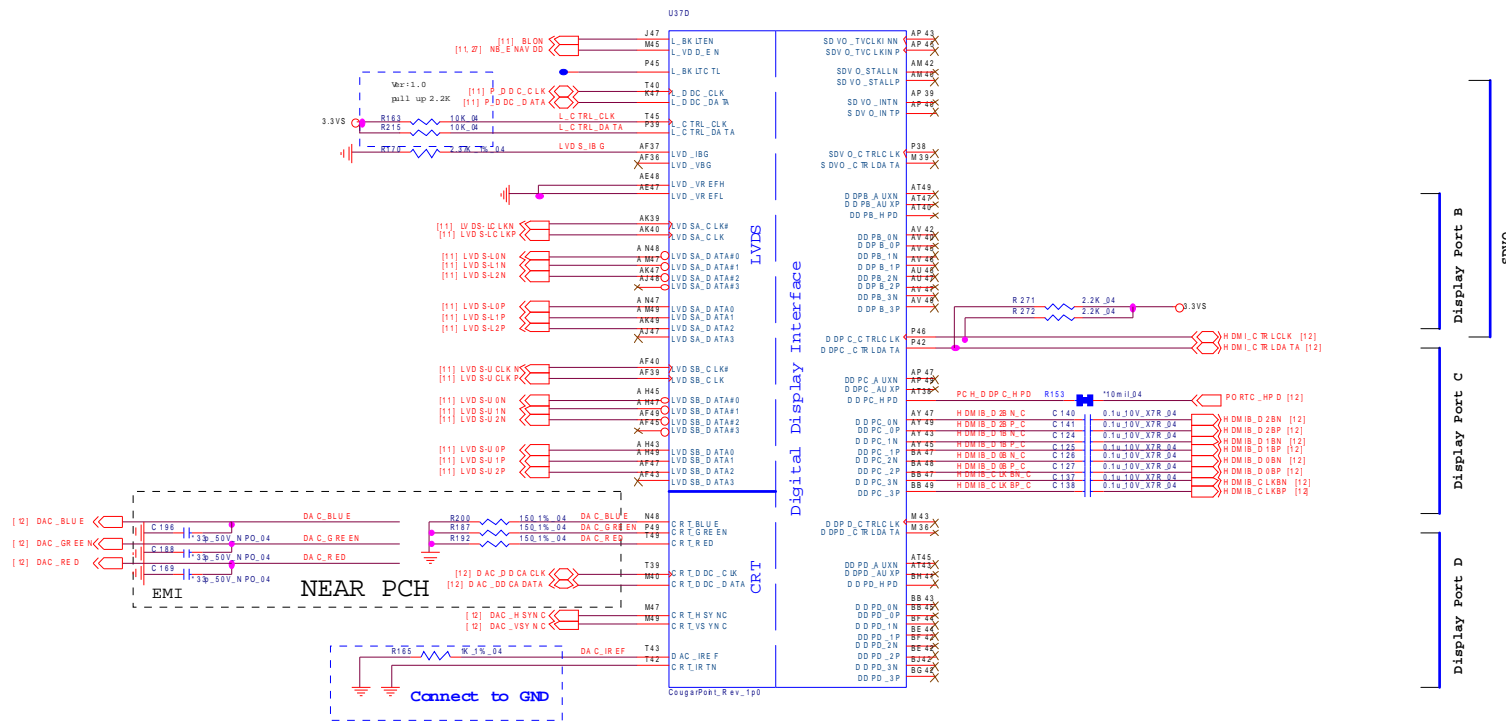

Sheet 16 of 43  
CougarPoint - M 4/9

B. Schematic Diagrams

[1, 12, 19, 20, 25, 28, 31, 36, 37] SVS  
[3, 8, 10, 11, 12, 14, 15, 17, 18, 19, 20, 23, 24, 25, 27, 28, 30, 31, 34] 3.3V5

# CougarPoint - M 5/9

Sheet 17 of 43  
CougarPoint - M 5/9

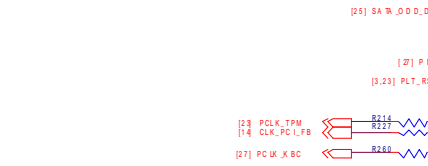
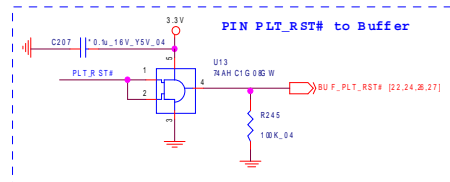
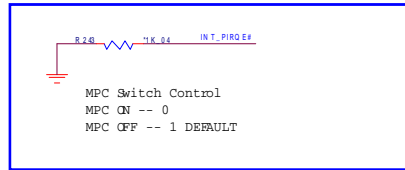
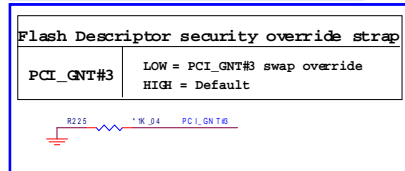
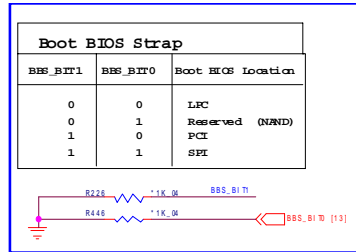

## CougarPoint -M (PCI,USB,NVRAM)

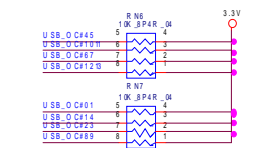
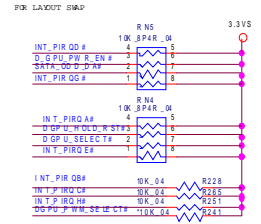
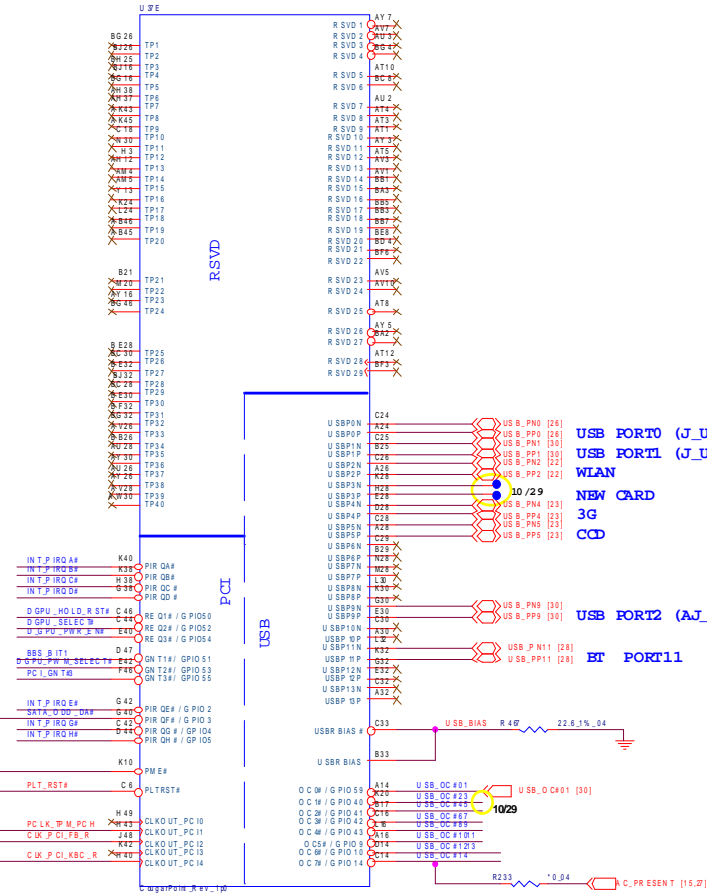

[23] PCLK\_TPM [14] CLK\_PC1\_FB [27] PCI\_X\_BC [25] SA\*\_ODD\*\_DA# [27] P\_ME# [3,23] P\_L\_T\_RST# [49] C\*\_PR\_ESEN\_T [15,27] [3,8,11,12,14,15,16,19,20,22,24,25,27,28,30,31,34,35,36,37,38,39,40,41,42,43,44,45,46,47,48,49,50,51,52,53,54,55,56,57,58,59,60,61,62,63,64,65,66,67,68,69,70,71,72,73,74,75,76,77,78,79,80,81,82,83,84,85,86,87,88,89,90,91,92,93,94,95,96,97,98,99,100,101,102,103,104,105,106,107,108,109,110,111,112,113,114,115,116,117,118,119,120,121,122,123,124,125,126,127,128,129,130,131,132,133,134,135,136,137,138,139,140,141,142,143,144,145,146,147,148,149,150,151,152,153,154,155,156,157,158,159,160,161,162,163,164,165,166,167,168,169,170,171,172,173,174,175,176,177,178,179,180,181,182,183,184,185,186,187,188,189,190,191,192,193,194,195,196,197,198,199,200,201,202,203,204,205,206,207,208,209,210,211,212,213,214,215,216,217,218,219,220,221,222,223,224,225,226,227,228,229,230,231,232,233,234,235,236,237,238,239,240,241,242,243,244,245,246,247,248,249,250,251,252,253,254,255,256,257,258,259,260,261,262,263,264,265,266,267,268,269,270,271,272,273,274,275,276,277,278,279,280,281,282,283,284,285,286,287,288,289,290,291,292,293,294,295,296,297,298,299,300,301,302,303,304,305,306,307,308,309,310,311,312,313,314,315,316,317,318,319,320,321,322,323,324,325,326,327,328,329,330,331,332,333,334,335,336,337,338,339,340,341,342,343,344,345,346,347,348,349,350,351,352,353,354,355,356,357,358,359,360,361,362,363,364,365,366,367,368,369,370,371,372,373,374,375,376,377,378,379,380,381,382,383,384,385,386,387,388,389,390,391,392,393,394,395,396,397,398,399,400,401,402,403,404,405,406,407,408,409,410,411,412,413,414,415,416,417,418,419,420,421,422,423,424,425,426,427,428,429,430,431,432,433,434,435,436,437,438,439,440,441,442,443,444,445,446,447,448,449,450,451,452,453,454,455,456,457,458,459,460,461,462,463,464,465,466,467,468,469,470,471,472,473,474,475,476,477,478,479,480,481,482,483,484,485,486,487,488,489,490,491,492,493,494,495,496,497,498,499,500,501,502,503,504,505,506,507,508,509,510,511,512,513,514,515,516,517,518,519,520,521,522,523,524,525,526,527,528,529,530,531,532,533,534,535,536,537,538,539,540,541,542,543,544,545,546,547,548,549,550,551,552,553,554,555,556,557,558,559,560,561,562,563,564,565,566,567,568,569,570,571,572,573,574,575,576,577,578,579,580,581,582,583,584,585,586,587,588,589,590,591,592,593,594,595,596,597,598,599,600,601,602,603,604,605,606,607,608,609,610,611,612,613,614,615,616,617,618,619,620,621,622,623,624,625,626,627,628,629,630,631,632,633,634,635,636,637,638,639,640,641,642,643,644,645,646,647,648,649,650,651,652,653,654,655,656,657,658,659,660,661,662,663,664,665,666,667,668,669,670,671,672,673,674,675,676,677,678,679,680,681,682,683,684,685,686,687,688,689,690,691,692,693,694,695,696,697,698,699,700,701,702,703,704,705,706,707,708,709,710,711,712,713,714,715,716,717,718,719,720,721,722,723,724,725,726,727,728,729,730,731,732,733,734,735,736,737,738,739,740,741,742,743,744,745,746,747,748,749,750,751,752,753,754,755,756,757,758,759,760,761,762,763,764,765,766,767,768,769,770,771,772,773,774,775,776,777,778,779,780,781,782,783,784,785,786,787,788,789,790,791,792,793,794,795,796,797,798,799,800,801,802,803,804,805,806,807,808,809,810,811,812,813,814,815,816,817,818,819,820,821,822,823,824,825,826,827,828,829,830,831,832,833,834,835,836,837,838,839,840,841,842,843,844,845,846,847,848,849,850,851,852,853,854,855,856,857,858,859,860,861,862,863,864,865,866,867,868,869,870,871,872,873,874,875,876,877,878,879,880,881,882,883,884,885,886,887,888,889,890,891,892,893,894,895,896,897,898,899,900,901,902,903,904,905,906,907,908,909,910,911,912,913,914,915,916,917,918,919,920,921,922,923,924,925,926,927,928,929,930,931,932,933,934,935,936,937,938,939,940,941,942,943,944,945,946,947,948,949,950,951,952,953,954,955,956,957,958,959,960,961,962,963,964,965,966,967,968,969,970,971,972,973,974,975,976,977,978,979,980,981,982,983,984,985,986,987,988,989,990,991,992,993,994,995,996,997,998,999,1000]

# CougarPoint - M 6/9

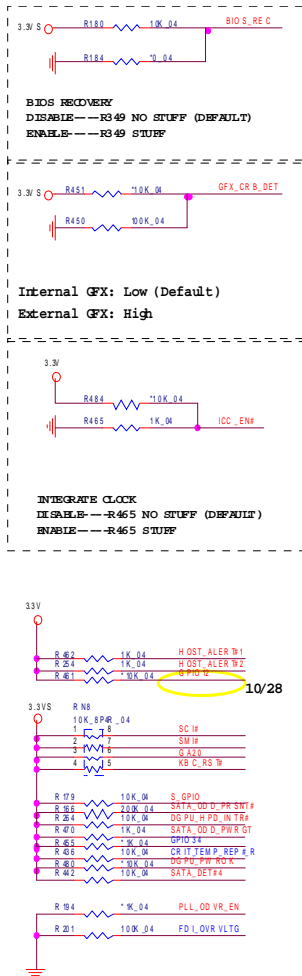

## CougarPoint - M (GPIO,VSS\_NCTF,RSVD)

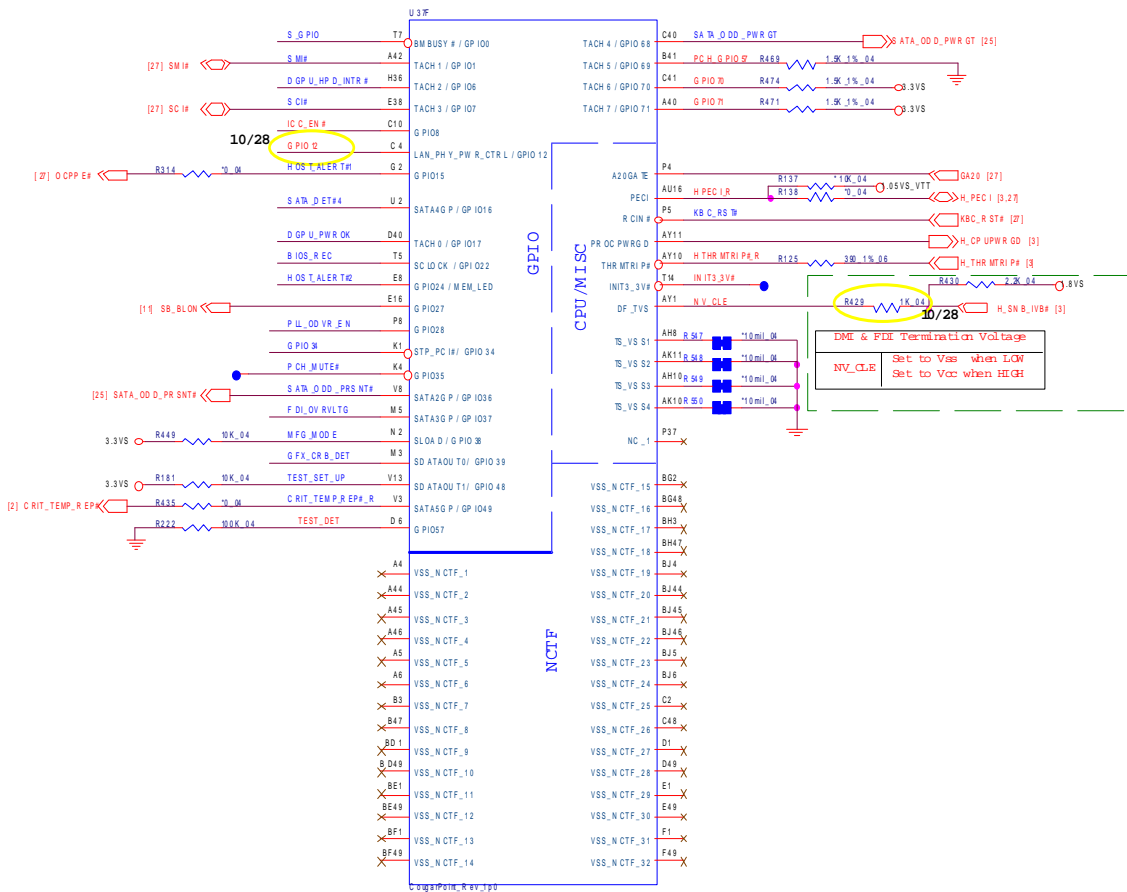

Sheet 18 of 43  
 CougarPoint - M 6/9

B.Schematic Diagrams

# CougarPoint - M 7/9

## CougarPoint -M (POWER)

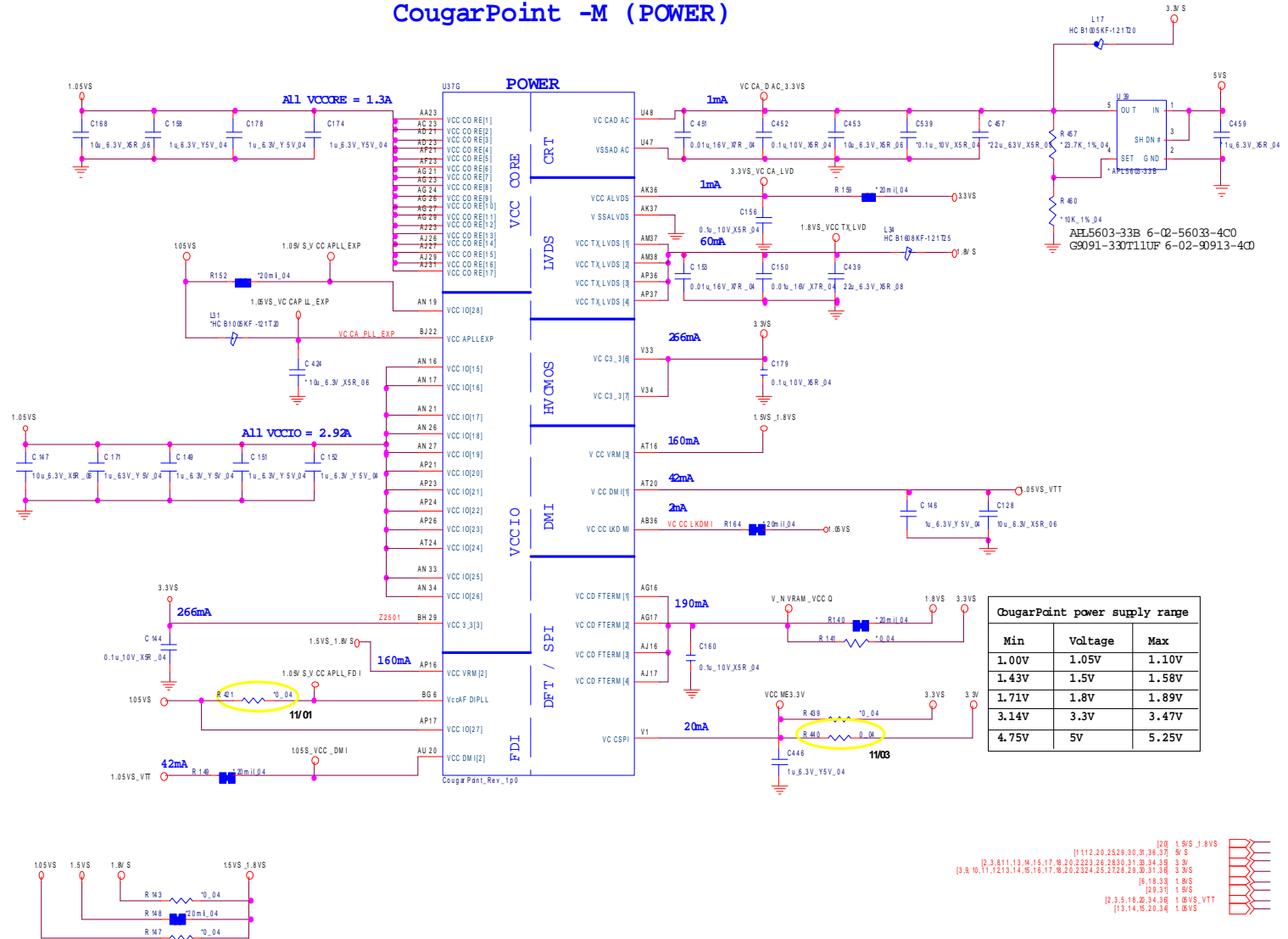

Sheet 19 of 43  
CougarPoint - M 7/9

# CougarPoint - M 8/9

CougarPoint power supply range		
Min	Voltage	Max
1.00V	1.05V	1.10V
1.43V	1.5V	1.58V
1.71V	1.8V	1.89V
3.14V	3.3V	3.47V
4.75V	5V	5.25V

## CougarPoint - M (POWER)

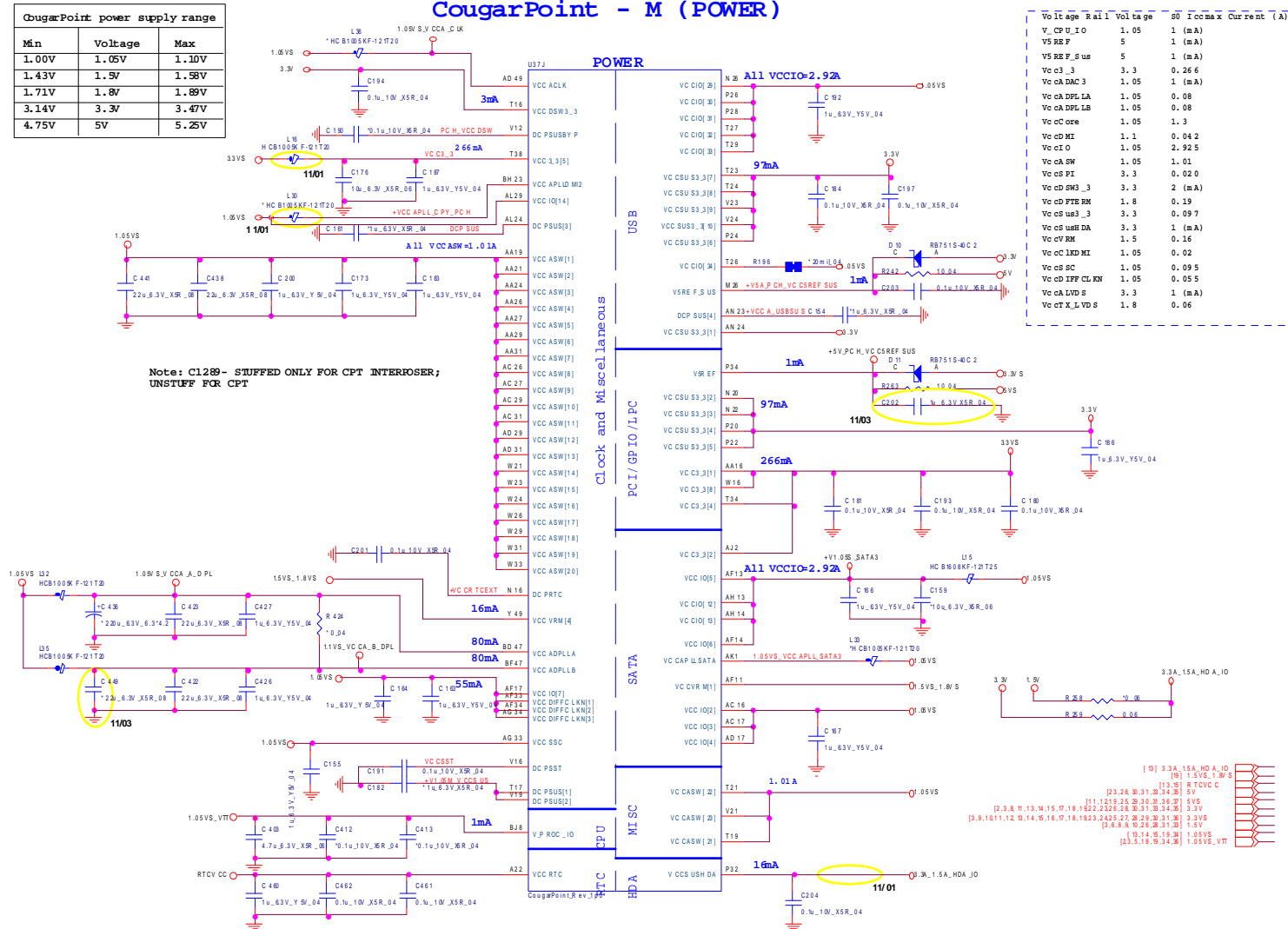

Sheet 20 of 43  
CougarPoint - M 8/9

B. Schematic Diagrams





# New Card, Mini PCIE

NEW CARD(Port 3)

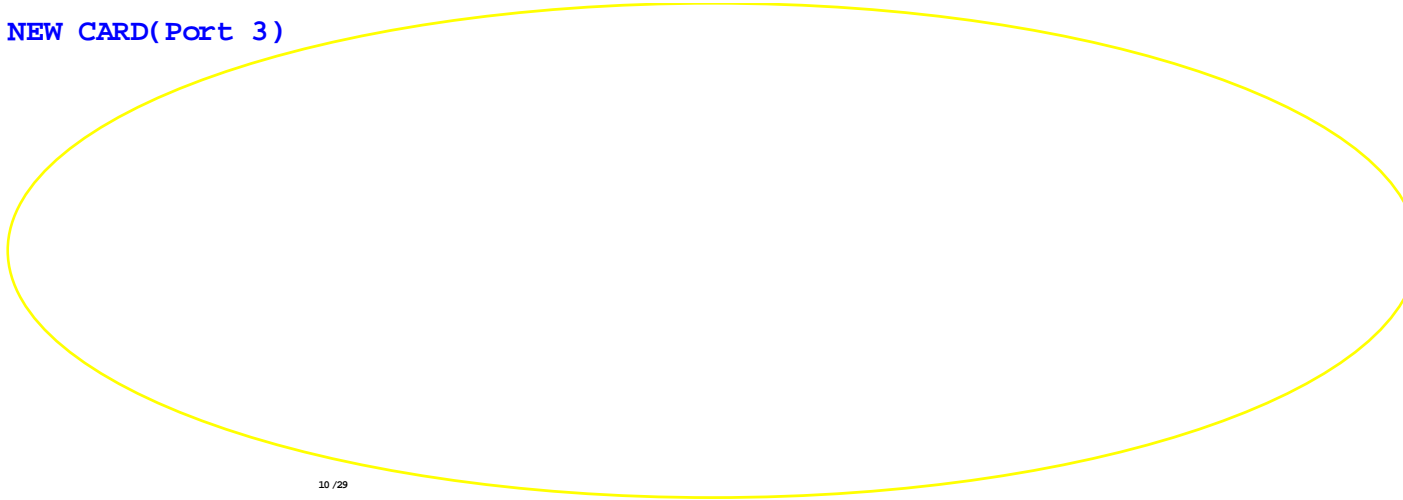

10 / 29

Sheet 22 of 43  
New Card, Mini PCIE

## MINI CARD WLAN

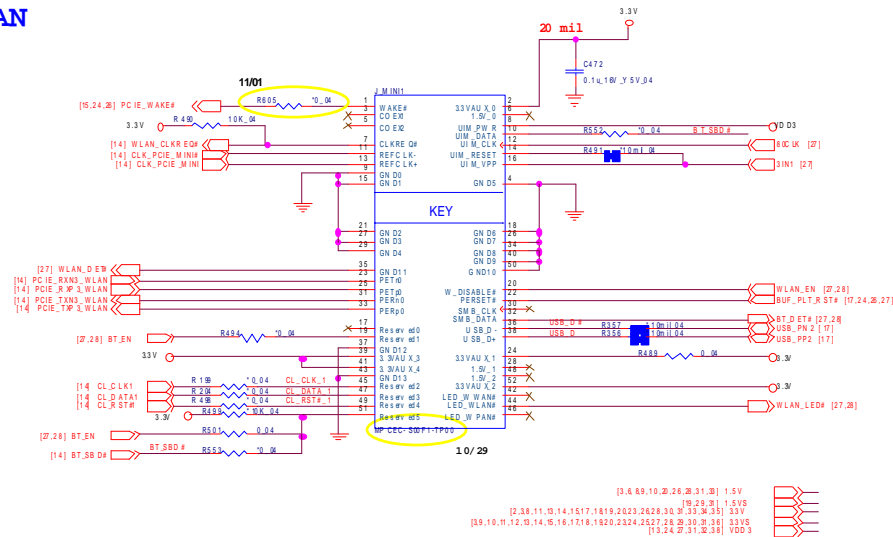

10 / 29

[3,8,9,10,20,26,30,31,30]	1.5V	
[2,28,11,10,14,15,17,18,19,20,22,26,28,30,31,33,34,35]	3.3V	
[9,10,11,12,13,14,15,16,17,18,19,20,22,24,25,27,28,29,30,31,36]	3.3V5	
[13,24,27,31,32,38]	VDD3	



# Card Reader/LAN JMC251C

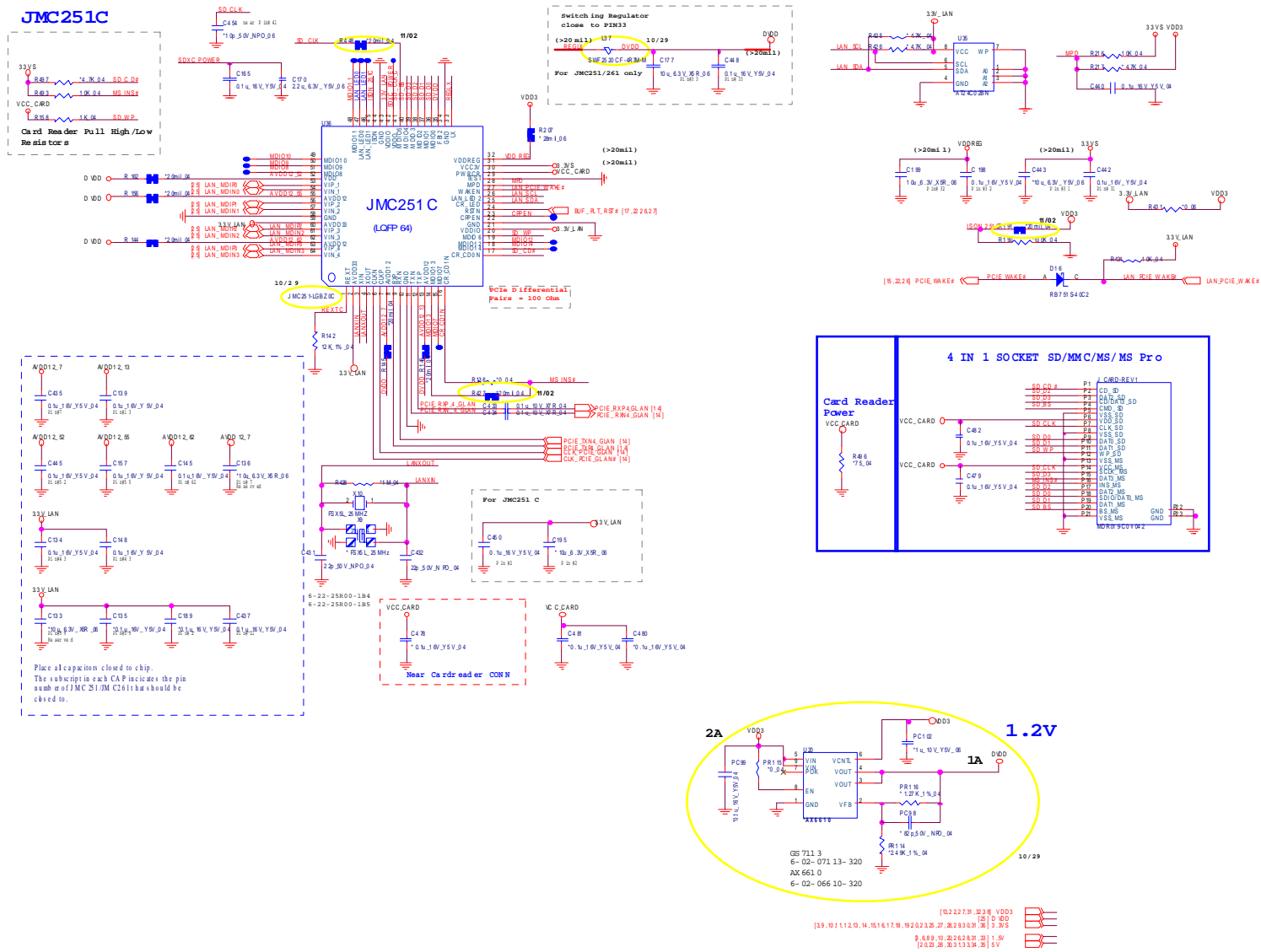

Sheet 24 of 43  
Card Reader/LAN  
JMC251C

B.Schematic Diagrams

# LAN (JMC251C), SATA HDD, ODD

B.Schematic Diagrams

Sheet 25 of 43  
LAN(JMC251C),  
SATA HDD, ODD

## GIGA LAN (JMC251C)

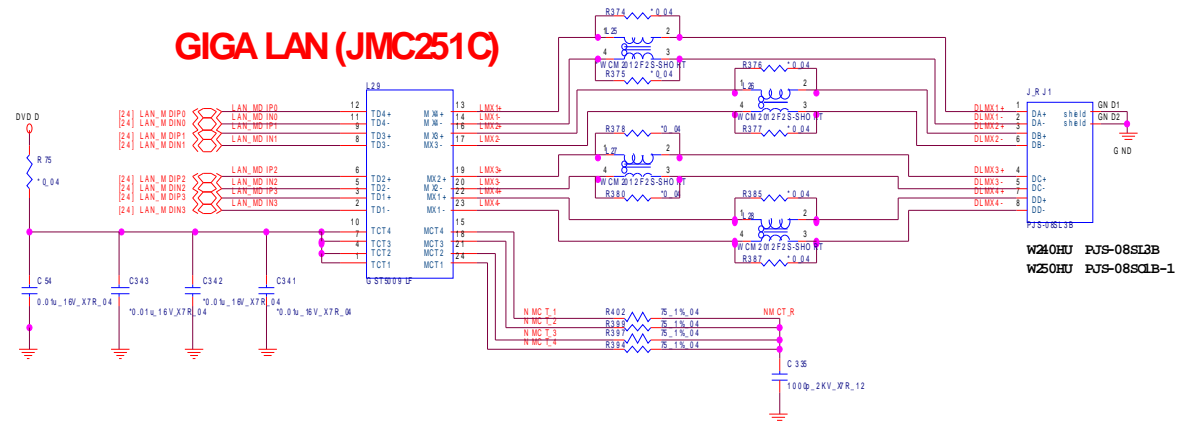

W240HU PJS-08SL3B  
W250HU PJS-08SCLB-1

## SATA HDD

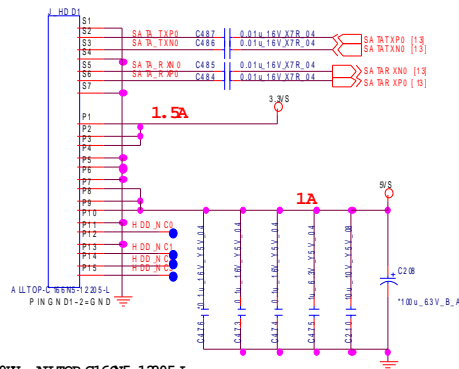

W240HU ALLTOP-C166N5-1.2205-L  
W250HU 1-1.62-1.0056L

## SATA ODD

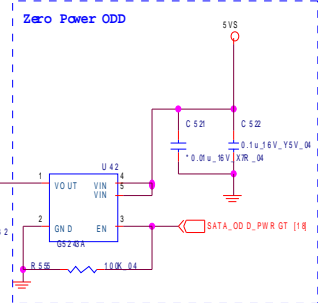
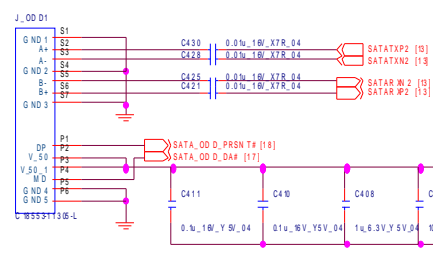

5VS [1:10,19,2029,3031,3637]  
VDD [0]  
3.3V [2,38,11,1314,1517,1819,2022,2326,28,30,31,33,34,35]  
1.5V [3,68,9,10,20,26,30,31,33]  
1.3V [5,6,10,11,12,13,14,15,16,17,18,19,2023,2427,2829,3031,38]

# USB 3.0 NEC, USB Charger

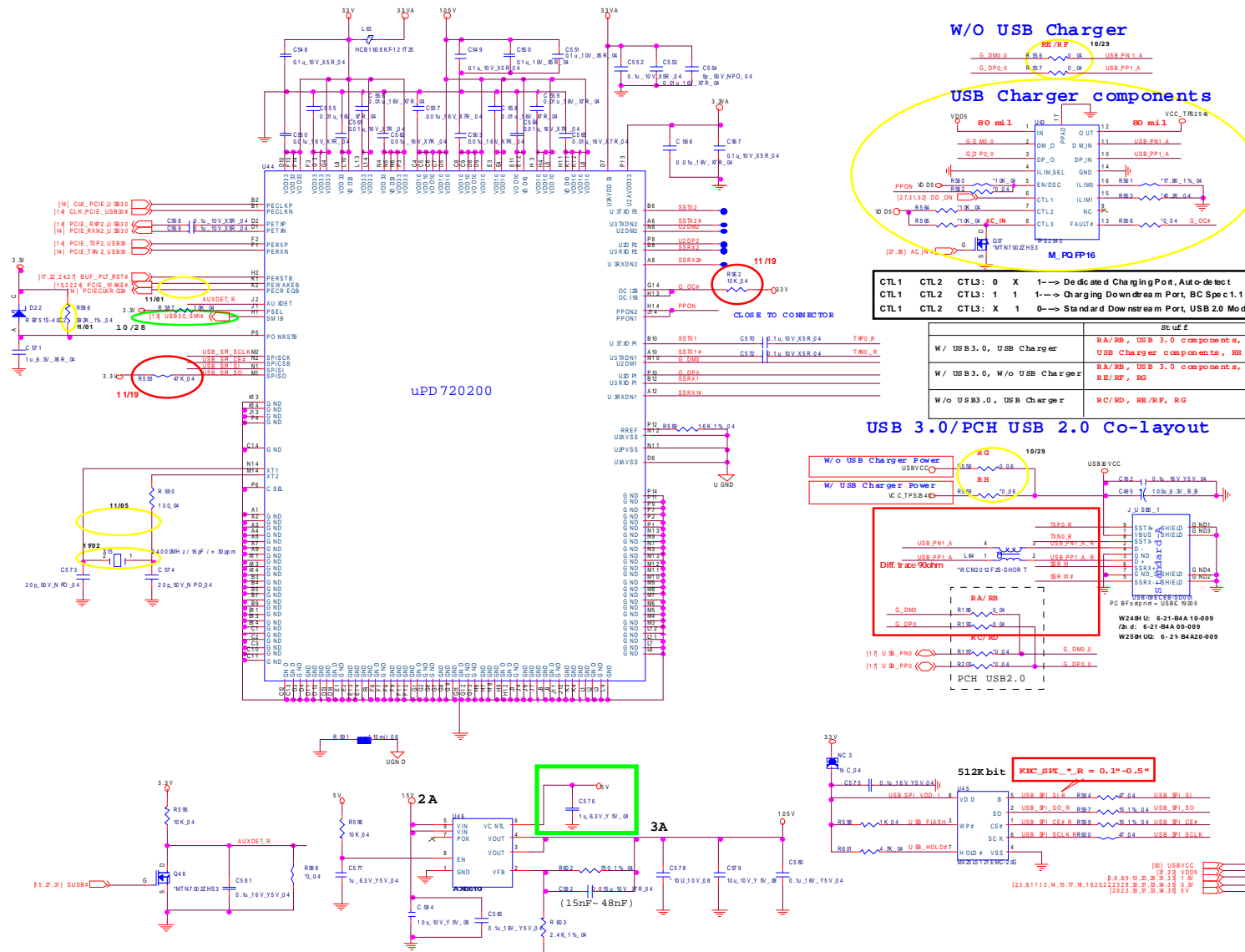

W/O USB Charger



USB Charger components

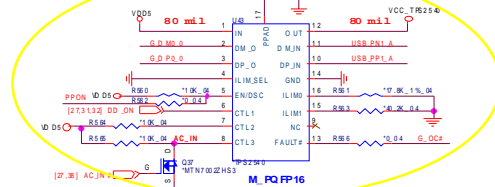

CTL1	CTL2	CTL3	0	X	1	→ De detect Charging Port, Auto-detect
CTL1	CTL2	CTL3	1	1	1	→ Charging Downstream Port, BC Spec 1.1
CTL1	CTL2	CTL3	X	1	0	→ Standard Downstream Port, USB 2.0 Mode

W/ USB 3.0, USB Charger	RA/RB, USB 3.0 component, USB Charger component, RH
W/ USB 3.0, W/o USB Charger	RA/RB, RG
W/o USB 3.0, USB Charger	RC/RD, RE/RP, RG

USB 3.0/PCH USB 2.0 Co-layout

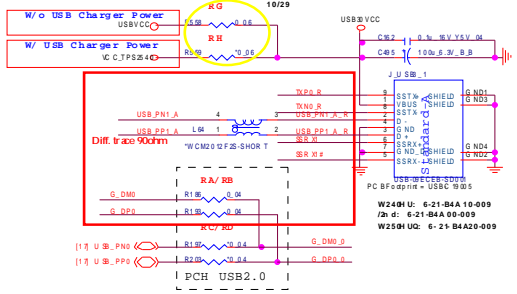

Sheet 26 of 43  
USB 3.0 NEC, USB  
Charger

B.Schematic Diagrams

# Schematic Diagrams

## KBC-ITE IT8518

B.Schematic Diagrams

Sheet 27 of 43  
KBC-ITE IT8518

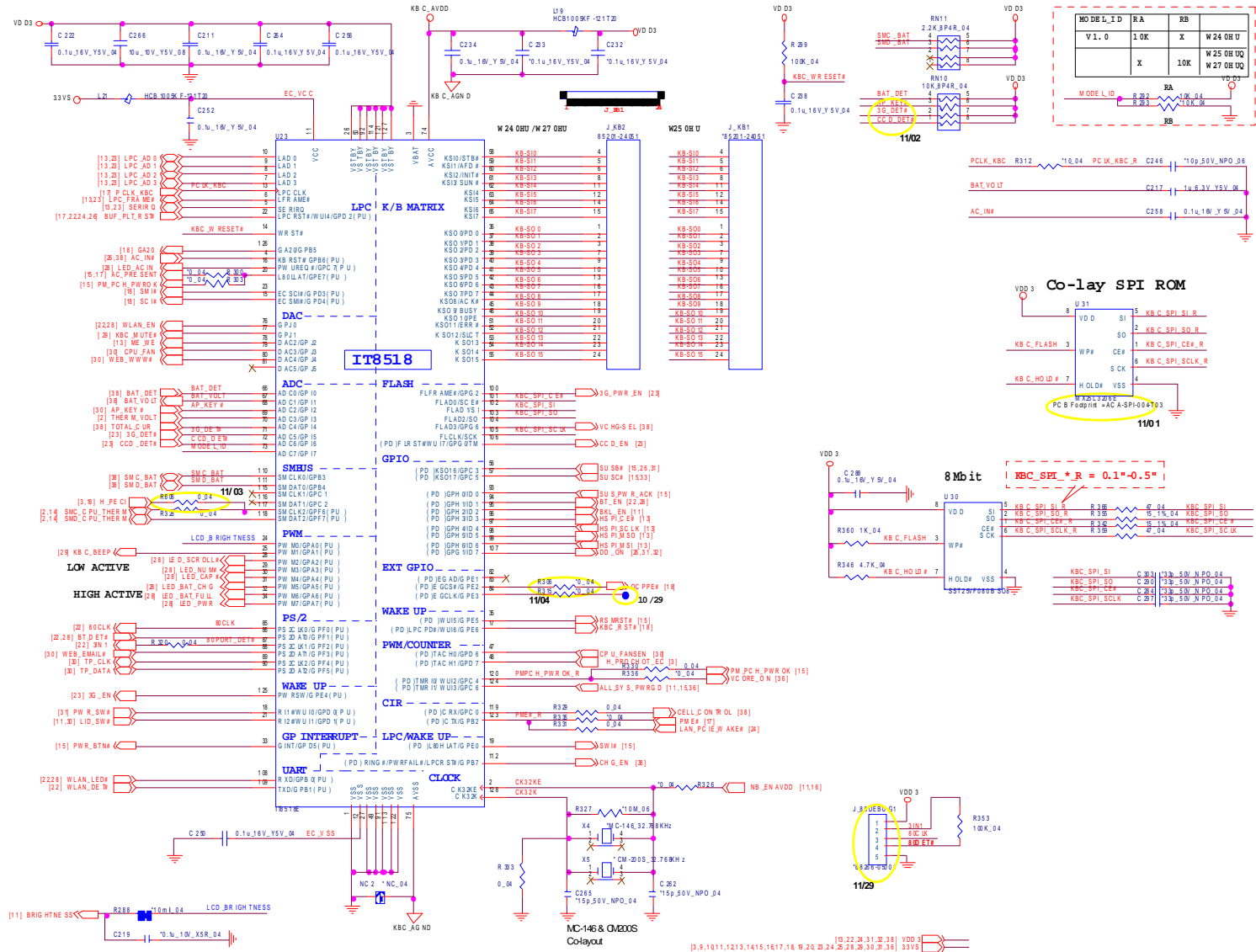

# LED, MDC, BT

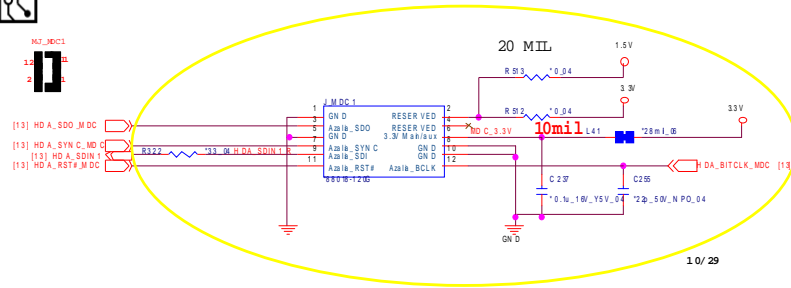

## Bluetooth (Port 8)

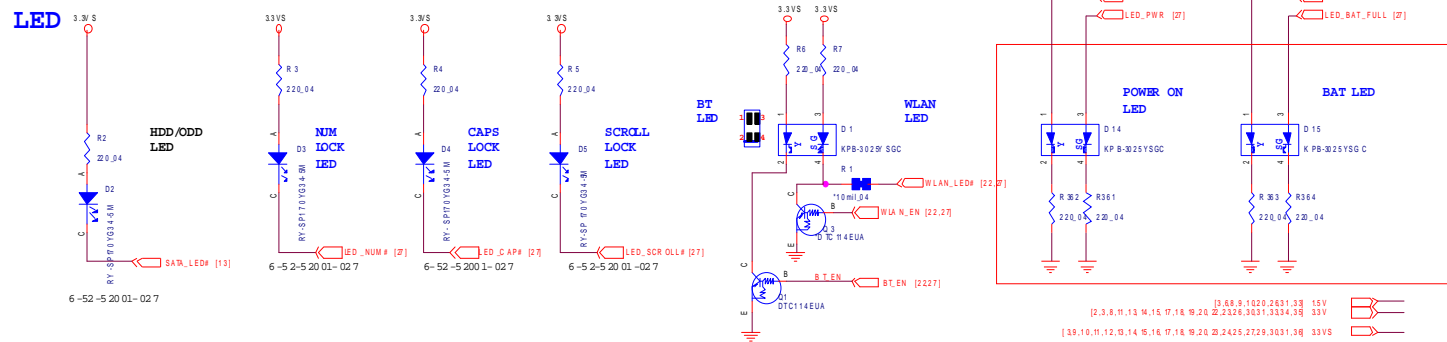
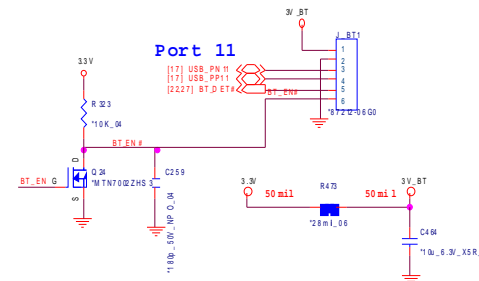

Sheet 28 of 43  
LED, MDC, BT

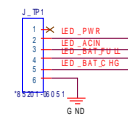
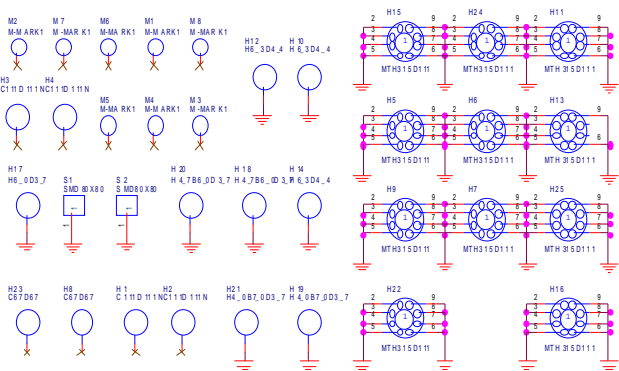

# Audio Codec ALC269

AUDIO CODEC  
ALC269 VB  
VT1802P

75 Component.

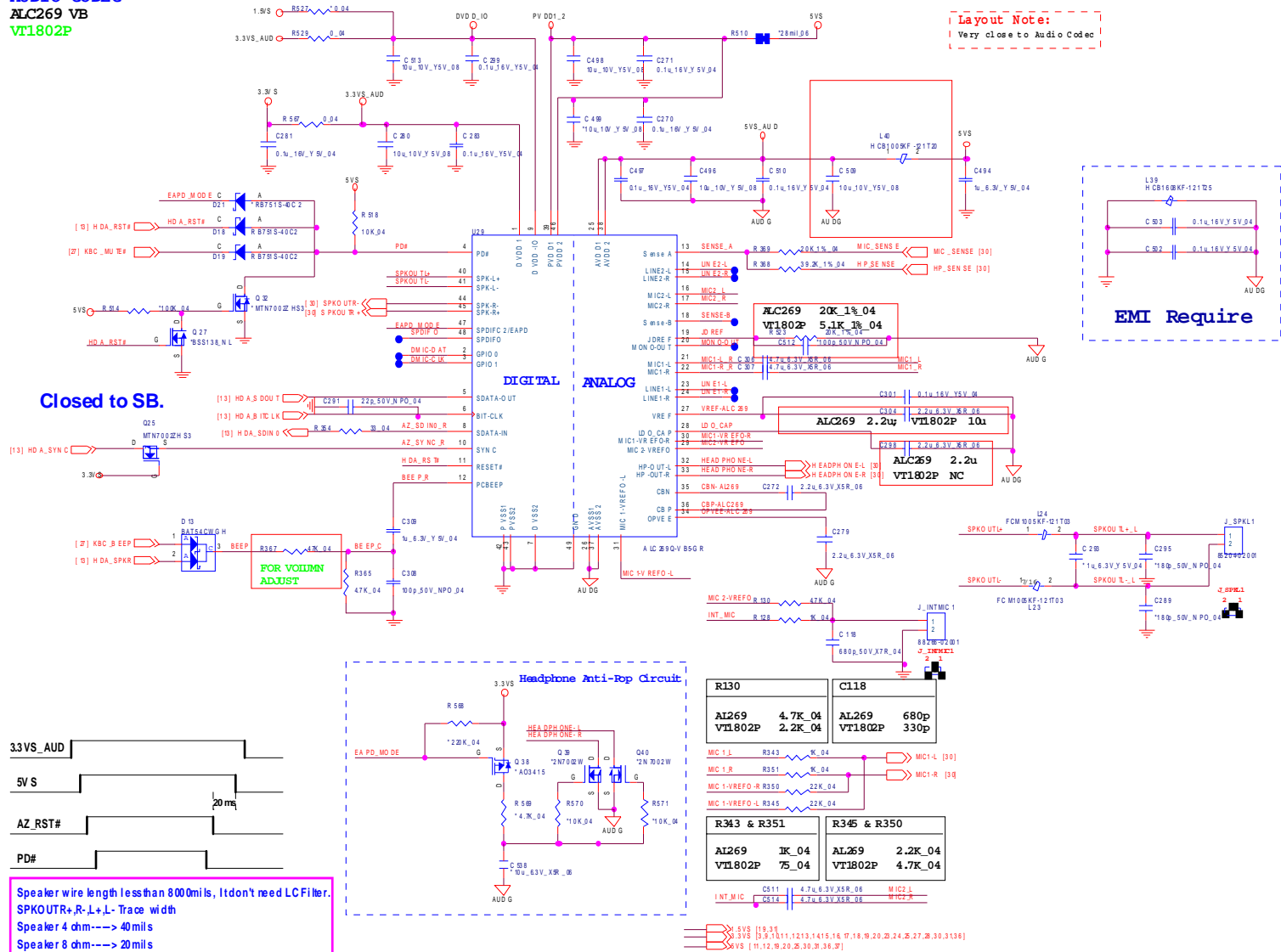

B.Schematic Diagrams

Sheet 29 of 43  
Audio Codec  
ALC269





# Schematic Diagrams

## 5VS, 3VS, 1.05VS, 1.5VS\_CPU

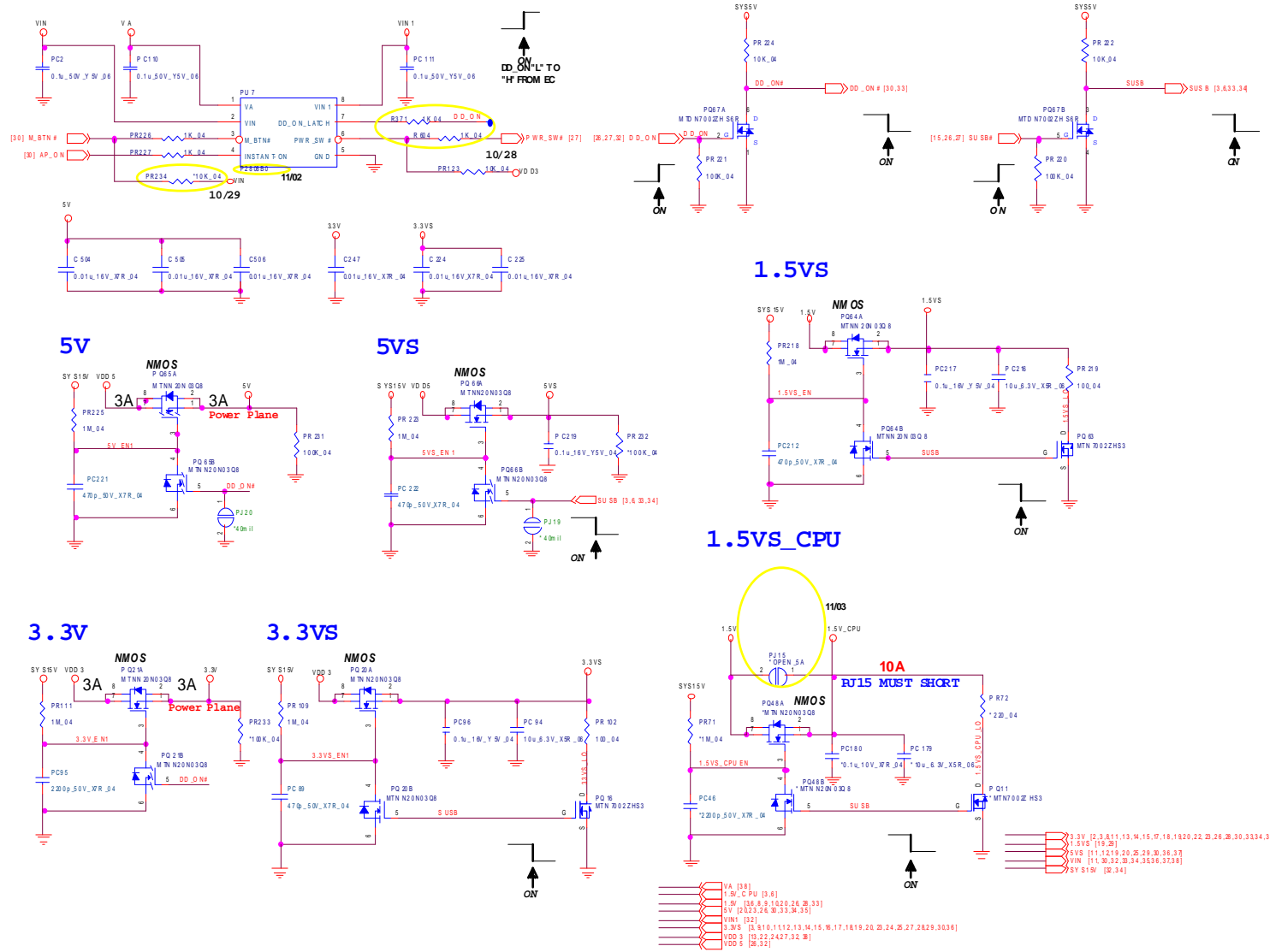

Sheet 31 of 43  
5VS, 3VS, 1.05VS,  
1.5VS\_CPU

B.Schematic Diagrams

# VDD3, VDD5

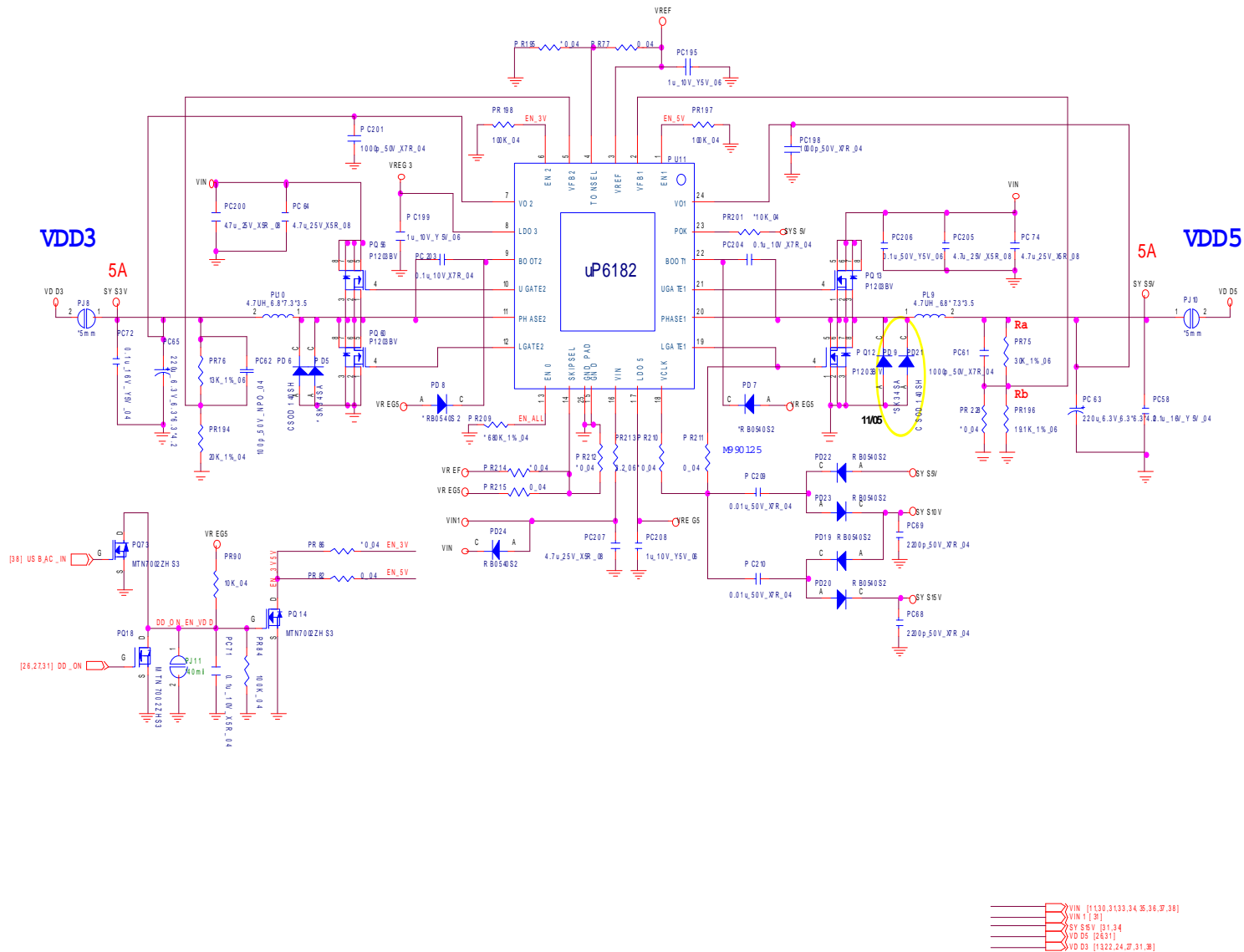

Sheet 32 of 43  
VDD3, VDD5

# Schematic Diagrams

## Power 1.5V/0.75V/1.8VS

Sheet 33 of 43  
Power 1.5V/0.75V/  
1.8VS

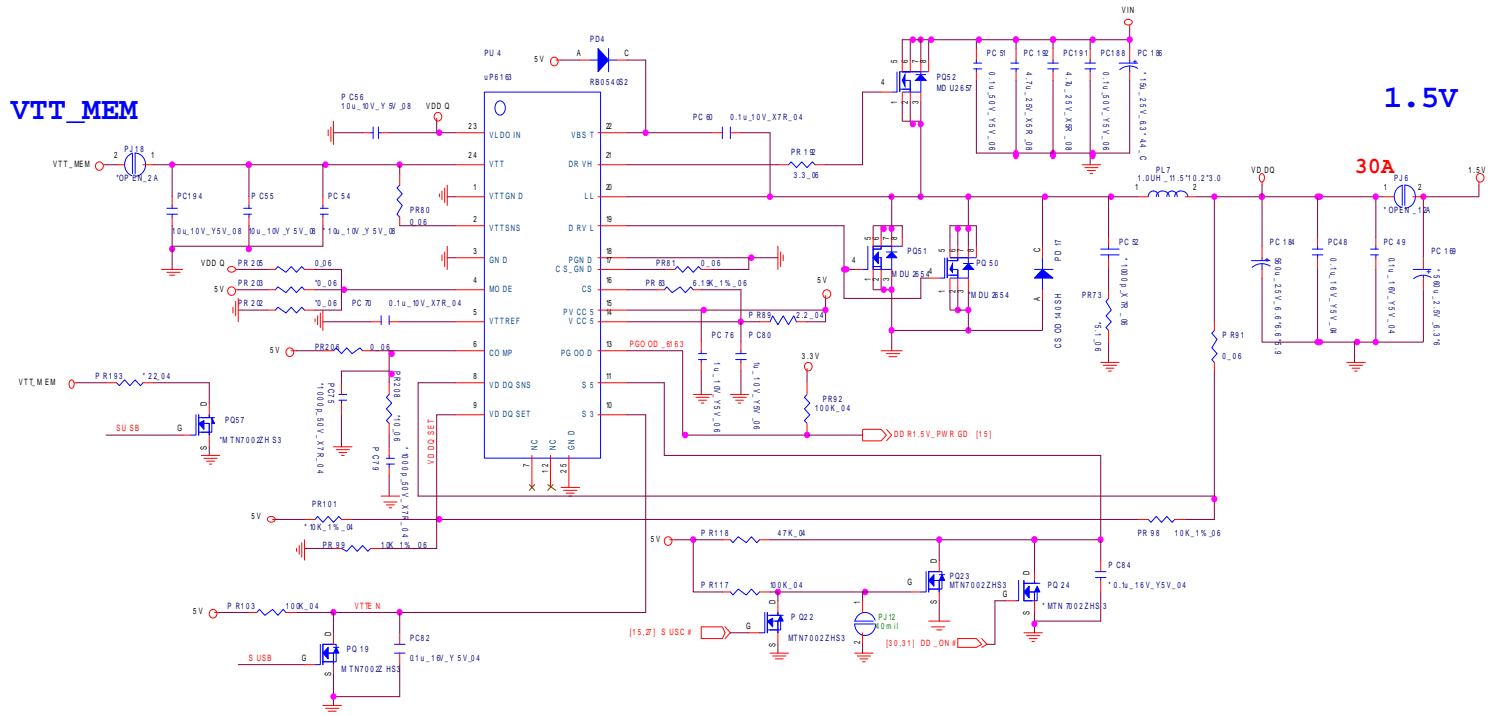

1.5V_CTRL1	1.5V_CTRL0	Voltage
1	1	1.55V
1	0	1.60V
0	1	1.65V
0	0	1.70V

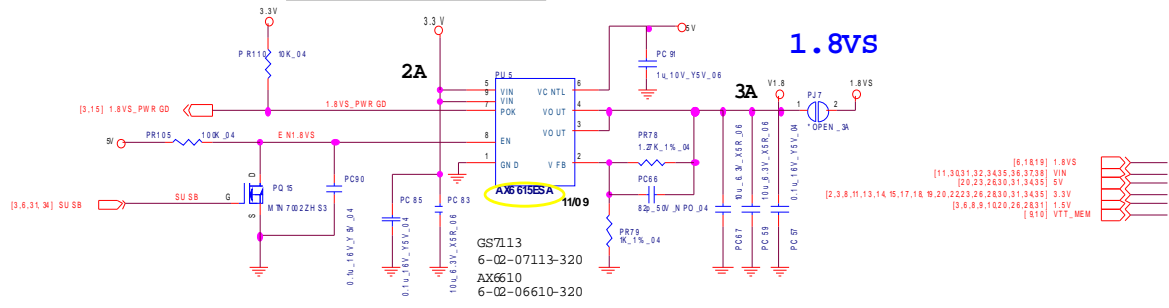

# Power 1.05VS

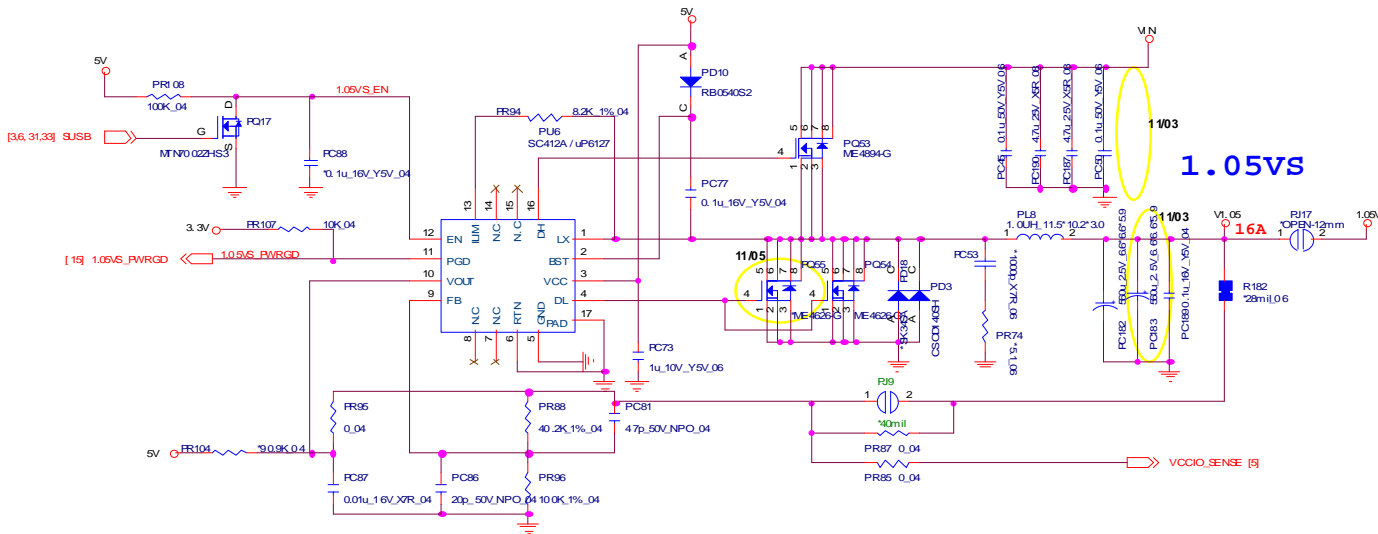

## 1.05VS\_VTT

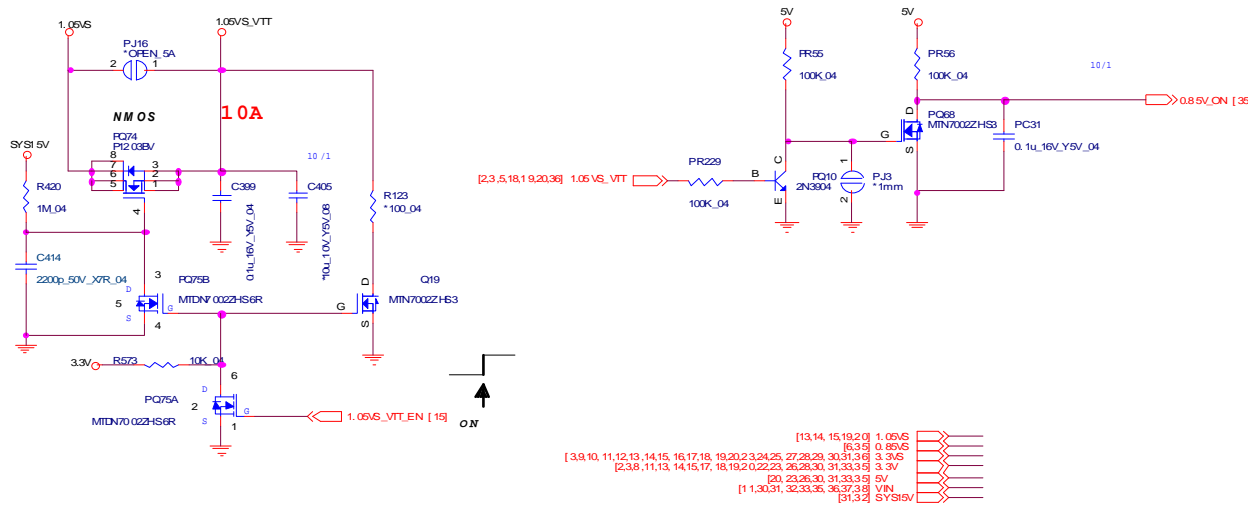

Sheet 34 of 43  
Power 1.05VS

B.Schematic Diagrams

# Power 0.85VS

VCCSA_VIDD	0.9V	0.8V	0.725V	0.645V
VCCSA_VIDL	0	0	1	1
	0	1	0	1

Sheet 35 of 43  
Power 0.85VS

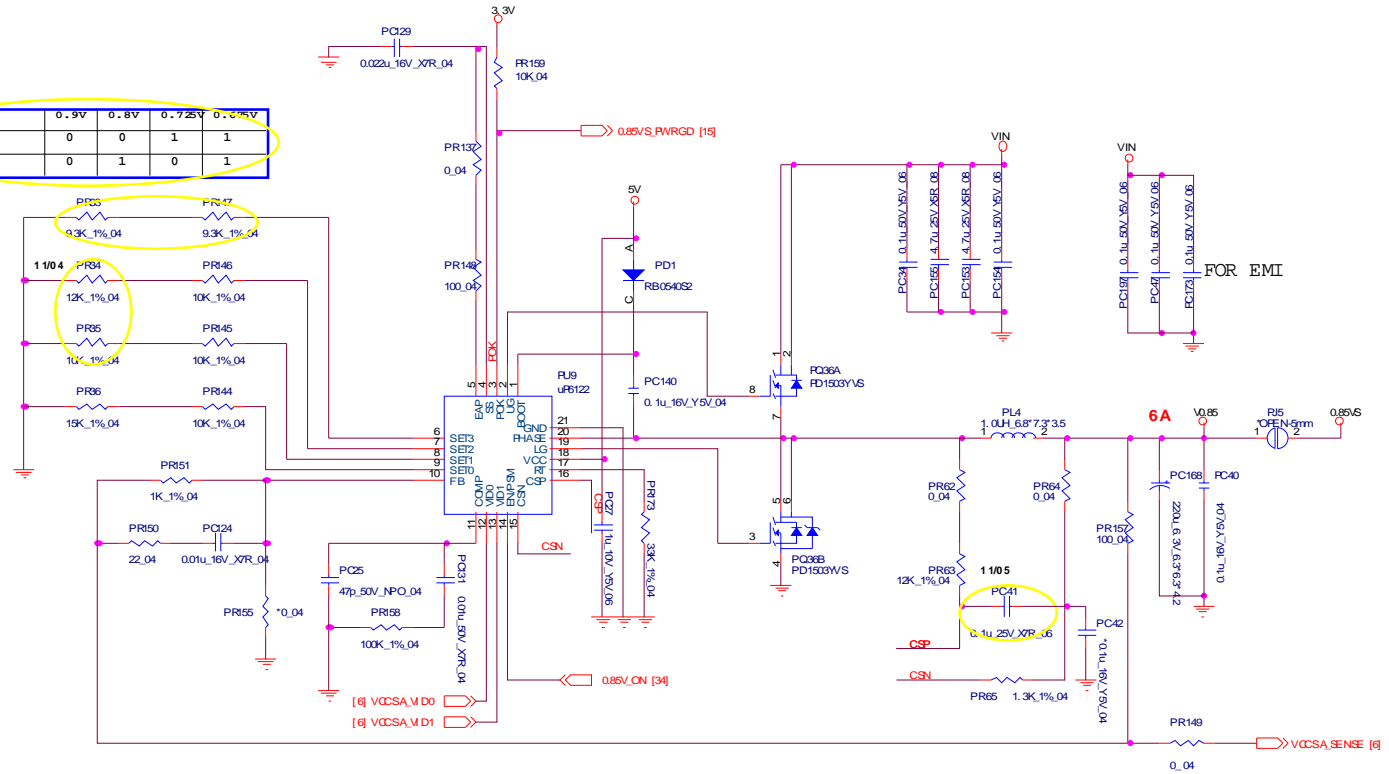

- 5V [20,23,26, 30,31,33,34]
- 0.85V [6]
- VIN [11,30,31, 32,33,34,36,37, 38]
- 3.3V [2,3, 8,11,13,14,15, 17,18,19,20,22, 23,26,28,30,31, 33,34]

# Power V-Core1

VCORE\_1

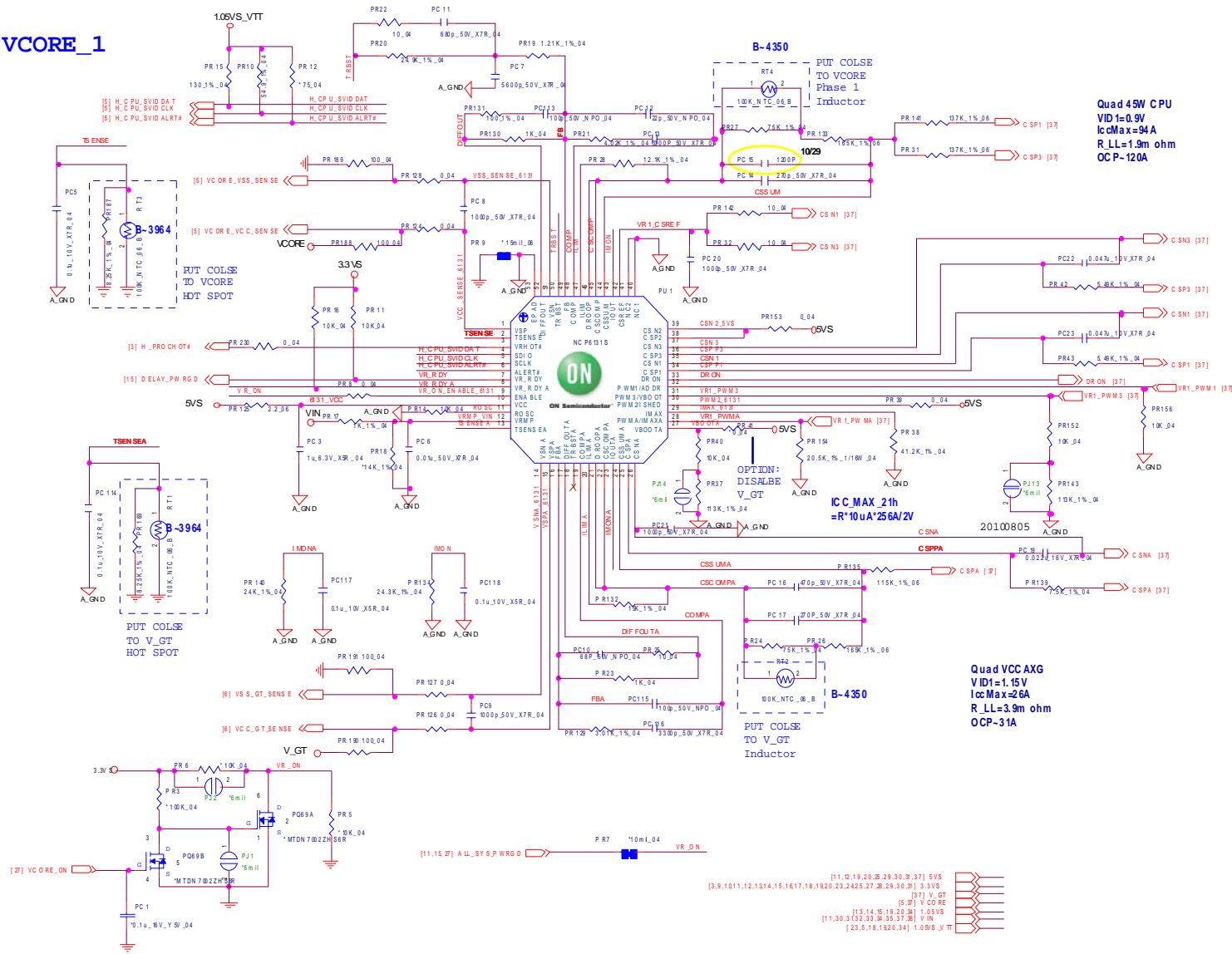

Sheet 36 of 43  
Power V-Core1

B. Schematic Diagrams

# Power V-Core2

Sheet 37 of 43  
Power V-Core2

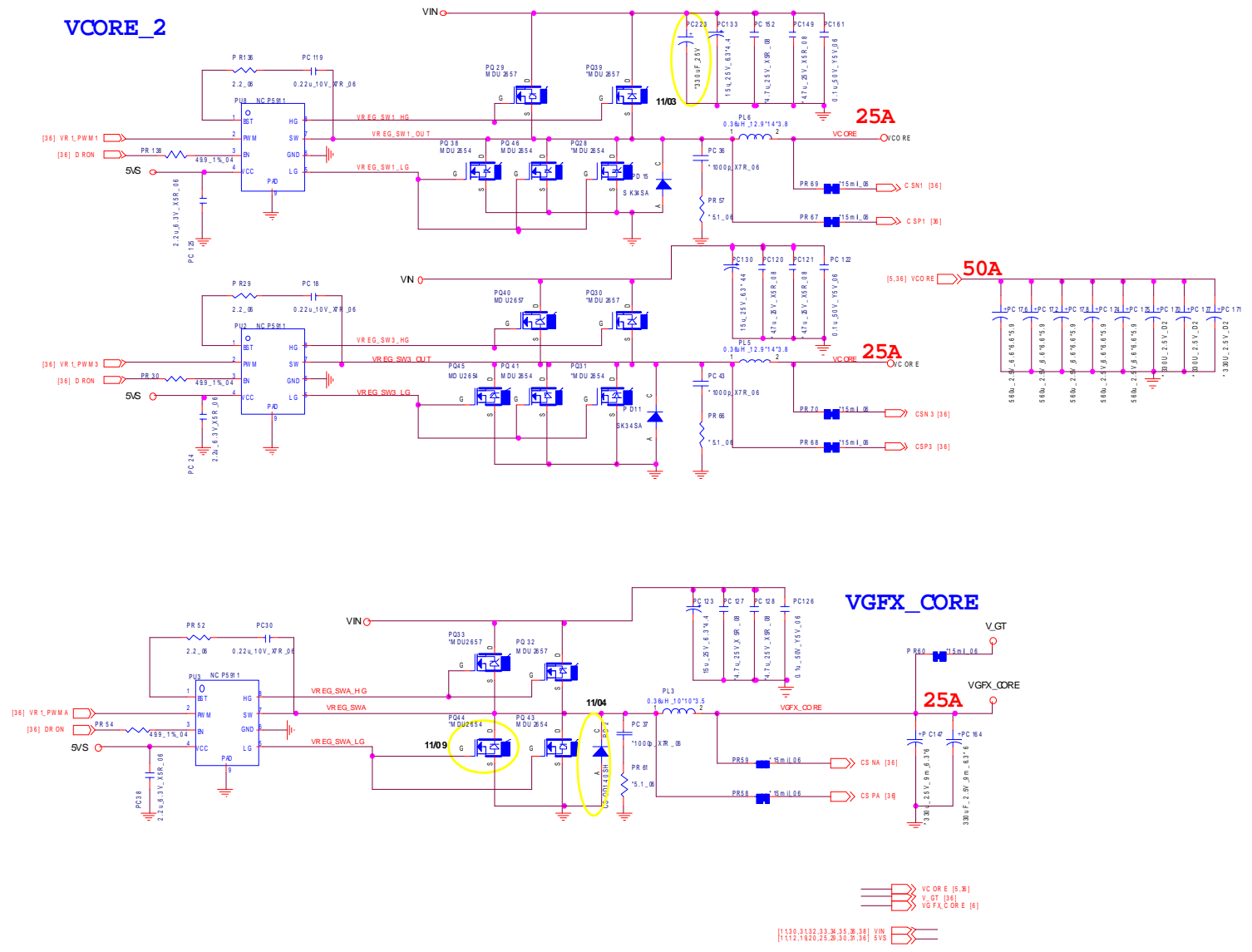



# Charger, DC In

## CHARGER

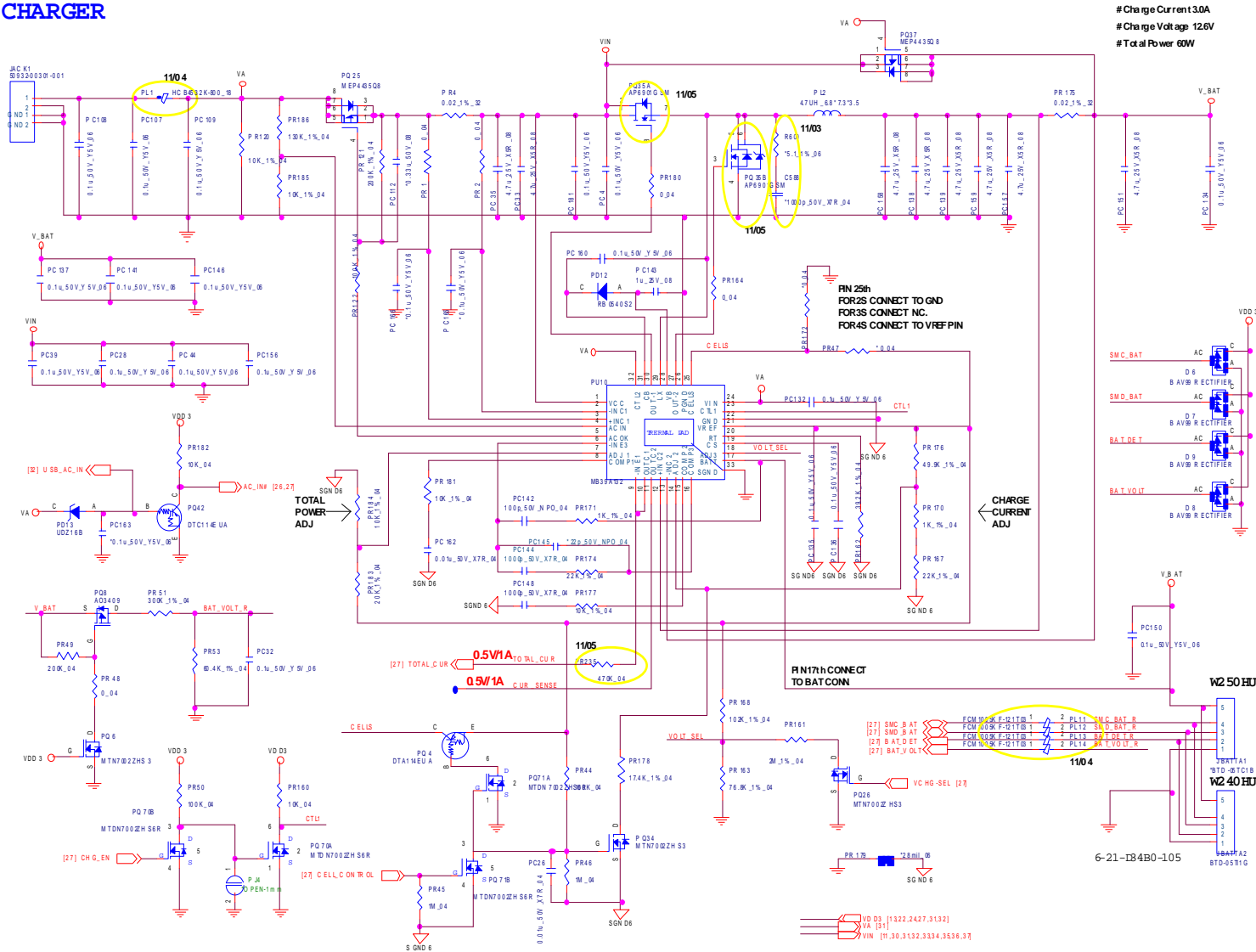

Sheet 38 of 43  
Charger, DC In

B.Schematic Diagrams

Schematic Diagrams

Click Board

CLICK BOARD

Sheet 39 of 43  
Click Board

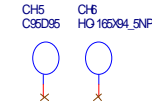
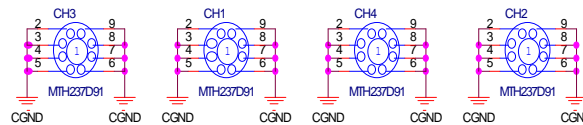
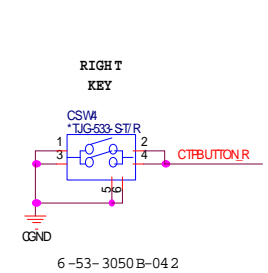
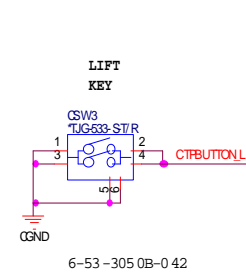
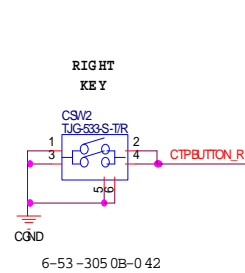
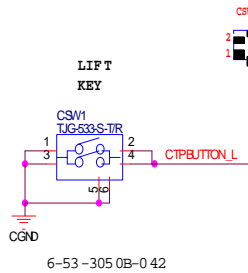
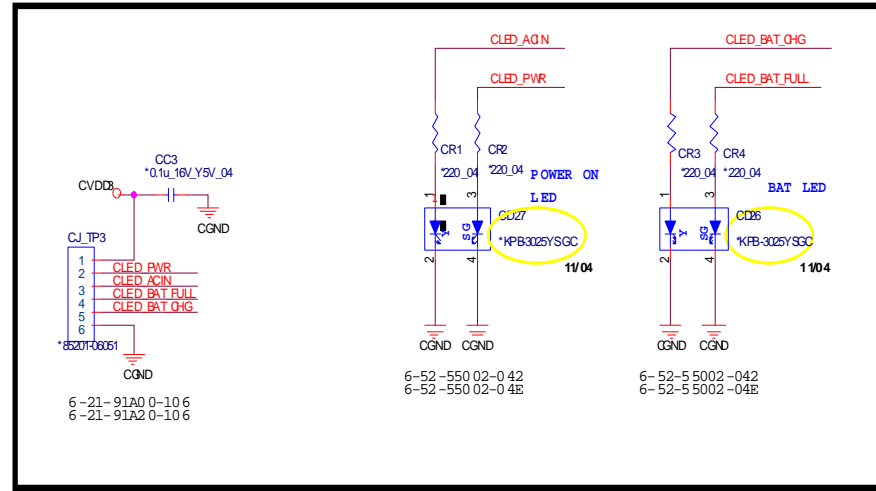
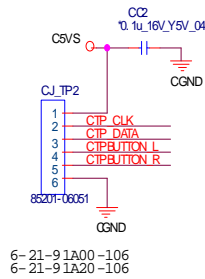
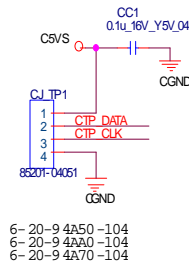

# Audio Board/USB

## USB PORT

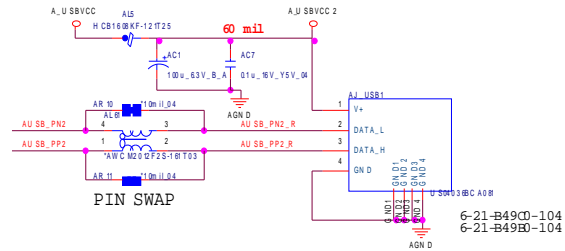
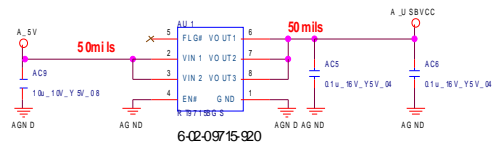

## TO M/B

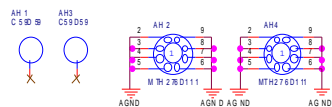
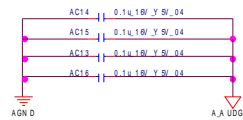
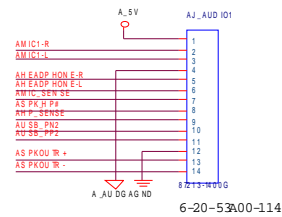

## AUDIO JACK

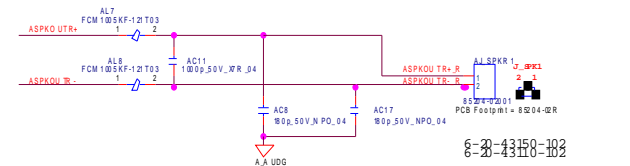
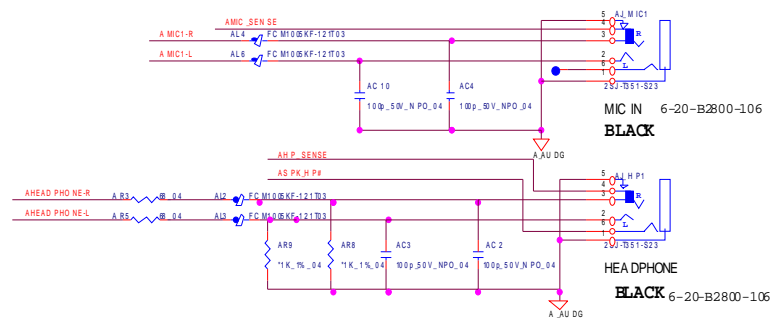

Sheet 40 of 43  
Audio Board/USB

# Power Switch & LID Board

POWER SW & LED & HOT KEY

Sheet 41 of 43  
Power Switch & LID Board

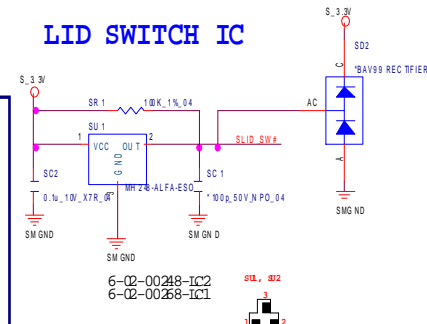
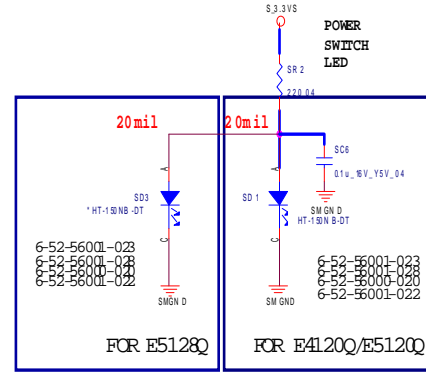
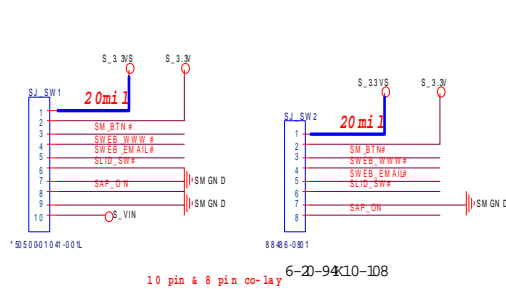

## HOT KEY

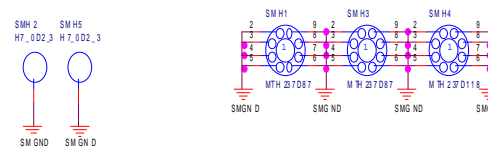
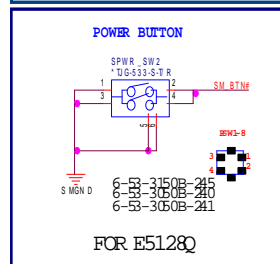
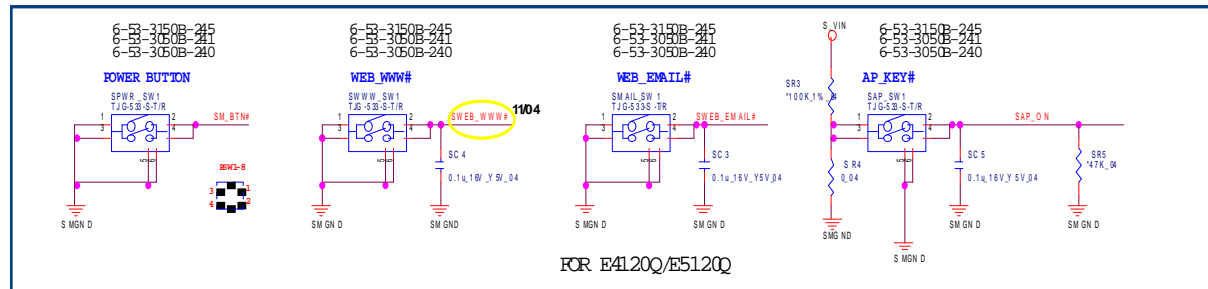

# External ODD Board

## ODD BOARD FOR E5120Q

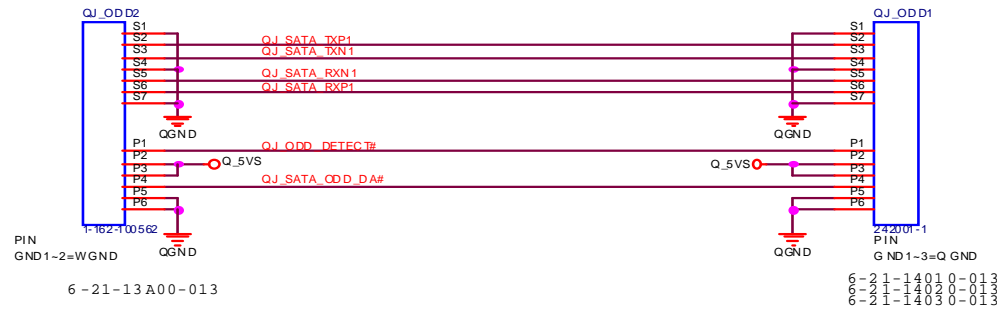

Sheet 42 of 43  
External ODD  
Board

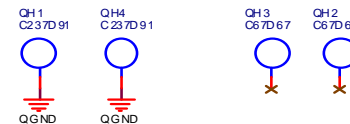
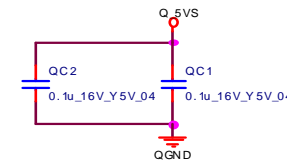

# Power Sequence

## W240HU/W250HUQ-D02 POWER ON SEQUENCE

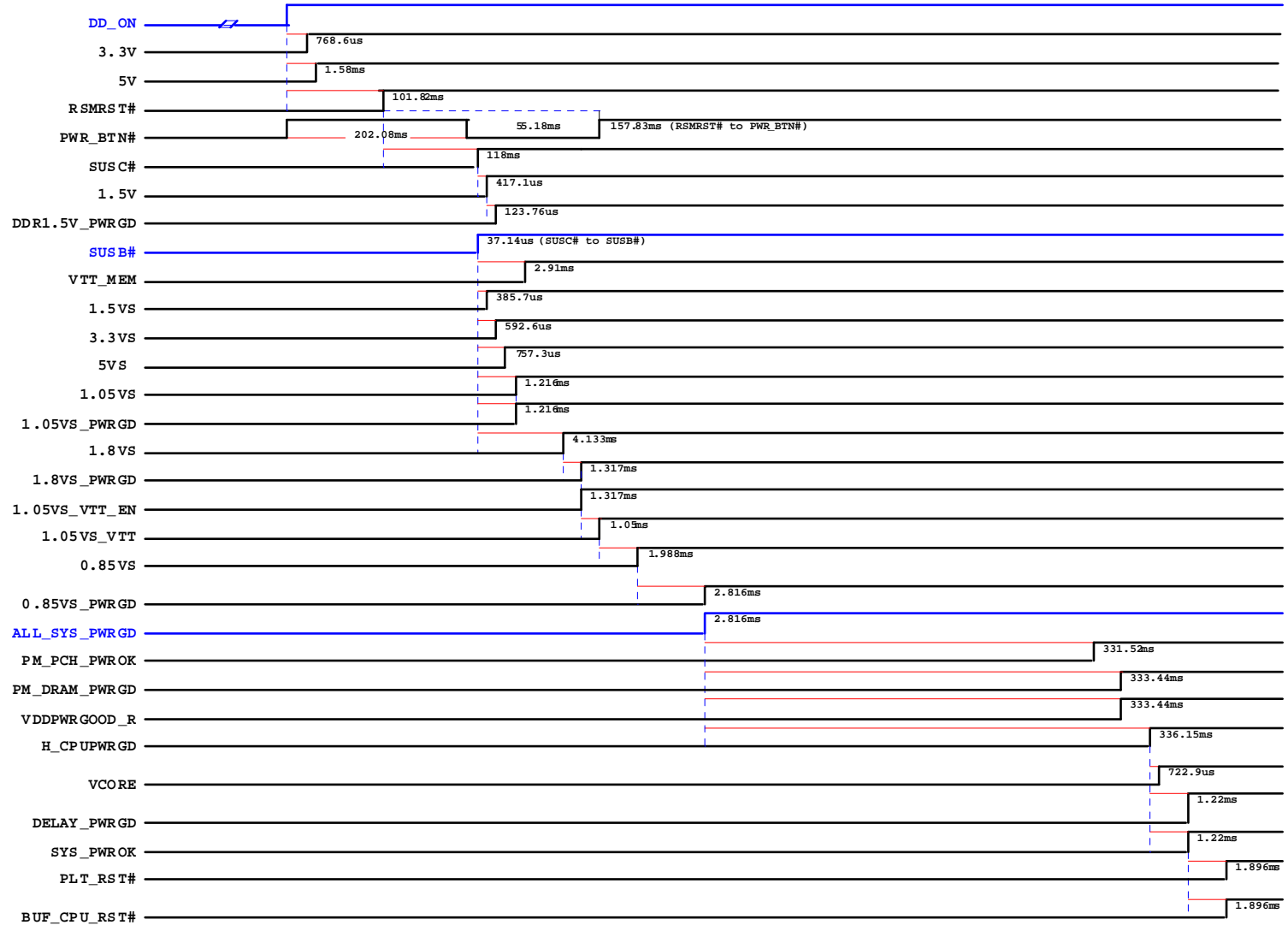

Sheet 43 of 43  
Power Sequence

# Appendix C: Updating the FLASH ROM BIOS

## To update the FLASH ROM BIOS you must:

- Download the BIOS update from the web site.
- Unzip the files onto a bootable CD/DVD/USB Flash Drive.
- Reboot your computer from an external CD/DVD/USB Flash Drive.
- Use the flash tools to update the flash BIOS using the commands indicated below.
- Restart the computer booting from the HDD and press **F2** at startup enter the BIOS.
- Load setup defaults from the BIOS and save the default settings and exit the BIOS to restart the computer.
- After rebooting the computer you may restart the computer again and make any required changes to the default BIOS settings.

## Download the BIOS

1. Go to [www.clevo.com.tw](http://www.clevo.com.tw) and point to **E-Services** and click **E-Channel**.
2. Use your user ID and password to access the appropriate download area (BIOS), and download the latest BIOS files (the BIOS file will be contained in a batch file that may be run directly once unzipped) for your computer model (see sidebar for important information on BIOS versions).

## Unzip the downloaded files to a bootable CD/DVD/ or USB Flash drive

1. Insert a bootable CD/DVD/USB flash drive into the CD/DVD drive/USB port of the computer containing the downloaded files.
2. Use a tool such as Winzip or Winrar to unzip all the BIOS files and refresh tools to your bootable CD/DVD/USB flash drive (you may need to create a bootable CD/DVD with the files using a 3rd party software).

## Set the computer to boot from the external drive

1. With the bootable CD/DVD/USB flash drive containing the BIOS files in your CD/DVD drive/USB port, restart the computer and press **F2** (in most cases) to enter the BIOS.
2. Use the arrow keys to highlight the **Boot** menu.
3. Use the “+” and “-” keys to move boot devices up and down the priority order.
4. Make sure that the CD/DVD drive/USB flash drive is set first in the boot priority of the BIOS.
5. Press **F10** to save any changes you have made and exit the BIOS to restart the computer.



### BIOS Version

Make sure you download the latest correct version of the BIOS appropriate for the computer model you are working on.

**You should only download BIOS versions that are V1.01.XX or higher** as appropriate for your computer model.

Note that BIOS versions are not backward compatible and therefore **you may not downgrade your BIOS to an older version** after upgrading to a later version (e.g if you upgrade a BIOS to ver 1.01.05, you **MAY NOT** then go back and flash the BIOS to ver 1.01.04).

## BIOS Update

---

### Use the flash tools to update the BIOS

1. Make sure you are not loading any memory management programs such as HIMEM by holding the **F8** key as you see the message “**Starting MS-DOS**”. You will then be prompted to give “**Y**” or “**N**” responses to the programs being loaded by DOS. Choose “**N**” for any memory management programs.
2. You should now be at the DOS prompt e.g: DISK C:\> (C is the designated drive letter for the CD/DVD drive/USB flash drive).
3. **Type the following command** at the DOS prompt:

**C:\> Flash.bat**

4. The utility will then proceed to flash the BIOS.
5. You should then be prompted to press any key to restart the system or turn the power off, and then on again but make sure you remove the CD/DVD/USB flash drive from the CD/DVD drive/USB port before the computer restarts.

### Restart the computer (booting from the HDD)

1. With the CD/DVD/USB flash drive removed from the CD/DVD drive/USB port the computer should restart from the HDD.
2. Press **F2** as the computer restarts to enter the BIOS.
3. Use the arrow keys to highlight the **Exit** menu.
4. Select **Load Setup Defaults** (or press **F9**) and select “**Yes**” to confirm the selection.
5. Press **F10** to save any changes you have made and exit the BIOS to restart the computer.

### Your computer is now running normally with the updated BIOS

You may now enter the BIOS and make any changes you require to the default settings.



[www.s-manuals.com](http://www.s-manuals.com)