



# CM6802A/B/AH/BH (Dynamic Soft PFC/Green PWM)

<http://www.championmicro.com.tw>

EPA/80++ ZVS-Like PFC/PWM COMBO CONTROLLER

Design for High Efficient Power Supply at both Full Load and Light Load

## GENERAL DESCRIPTION

Switching to CM6802A/B/AH/BH from your existing CM6800 family boards can gain the following advanced performances:

- 1.) Around 2% efficiency gain when the output load is below 40% of the full load.
- 2.) Hold Up time can be increased ~ 30% from the existing 6800 power supply.
- 3.) 420V bulk capacitor value may be reduced PFC boost ripple current can be reduced; therefore, the boost inductor core size maybe reduced.
- 4.) No Load Consumption can be reduced 290mW at 270VAC.
- 5.) PWM transformer size can be smaller.
- 6.) To design 12V, 5V and 3.3V output filters can be easy.
- 7.) The stress over the entire external power device is reduced and EMI noise maybe reduced.
- 8.) Monotonic Output design is easy and more...Of cause, the cost will be reduced.

CM6802A/B/AH/BH is pin to pin compatible with CM6800 family.

Beside all the goodies in the CM6800, it is designed to meet the EPA/80+ regulation. With the proper design, its efficiency of power supply can easily approach 85%.

To start evaluating CM6802A/B/AH/BH from the exiting CM6800,CM6800A or ML4800 board, 6 things need to be taken care before doing the fine tune:

- 1.) Change RAC resistor (on pin 2, IAC) from the old value to a higher resistor value between 4.7 Mega ohms to 8 Mega ohms.
- 2.) Change RTCT pin (pin 7) from the existing value to RT=7.75K ohm and CT=1000pF to have f<sub>pfc</sub>=55Khz, f<sub>pwm</sub>=55Khz, f<sub>rtct</sub>=220Khz.
- 3.) Adjust all high voltage resistor around 5 mega ohm or higher.
- 4.) VRMS pin (pin 4) needs to be 1.125V at VIN=85VAC for universal input application from line input from 85VAC to 270VAC. Both poles for the Vr<sub>ms</sub> of the CM6802A/B/AH/BH needs to substantially slow than CM6800 about 5 to 10 times.
- 5.) At full load, the average Ve<sub>ao</sub> needs to around 4.5V and the ripple on the Ve<sub>ao</sub> needs to be less than 250mV.
- 6.) Soft Start pin (pin 5), the soft start current has been reduced from CM6800's 20uA to CM6802A/B/AH/BH's 10uA.Soft Start capacitor can be reduced to 1/2 from your original CM6800 capacitor.

## FEATURES

- ◆ Patents Pending
- ◆ Pin to pin compatible with CM6800,CM6800A, ML4800 and FAN4800.
- ◆ 23V Bi-CMOS process.
- ◆ Designed for EPA/80++ efficiency.
- ◆ CM6802A/B : Selectable Boost output from 380V to 300V during light load.
- ◆ CM6802AH/BH: Selectable Boost output from 380V to 342V during light load.
- ◆ All high voltage resistors can be greater than 4.7 Mega ohm (4.7 Mega to 8 Mega ohm) to improve the no load consumption.
- ◆ Rail to rail CMOS Drivers with on, 60 ohm and off, 30 ohm for both PFC and PWM with two 17V zeners.
- ◆ Fast Start-UP Circuit without extra bleed resistor to aid VCC reaches 13V sooner.
- ◆ Low start-up current (55uA typ.)
- ◆ Low operating current (2.5mA typ.)
- ◆ 16.5V VCC shunt regulator
- ◆ Leading Edge Blanking for both PFC and PWM.
- ◆ f<sub>RTCT</sub> = 4\*f<sub>pfc</sub> =4\*f<sub>pwm</sub> for CM6802A//AH
- ◆ f<sub>RTCT</sub> = 4\*f<sub>pfc</sub> =2\*f<sub>pwm</sub> for CM6802B/BH
- ◆ Dynamic Soft PFC to ease the stress of the Power Device and Ease the EMI filter design.
- ◆ PFC Brown Out and PWM Brown Out
- ◆ Internally synchronized leading edge PFC and trailing edge PWM in one IC to Reduces ripple current in the 420V storage capacitor between the PFC and PWM sections.
- ◆ Low total harmonic distortion, THD and Power Factor approaches 1.0.
- ◆ Average current, continuous or discontinuous boost leading edge PFC.
- ◆ PWM configurable for current mode or feed-forward voltage mode operation.
- ◆ Current fed Gain Modulator for improved noise immunity.
- ◆ Gain Modulator is a constant maximum power limiter.
- ◆ Brown-out control, over-voltage protection, UVLO, and soft start, and Reference OK.
- ◆ PWM Short Circuit Protection
- ◆ Power Fold Back Protection
- ◆ Green Mode PWM for less no load consumption.

## APPLICATIONS

- ◆ EPA/80++ related Power Supply
- ◆ Desktop PC Power Supply
- ◆ Internet Server Power Supply
- ◆ LCD Power Supply
- ◆ PDP Power Supply
- ◆ IPC Power Supply
- ◆ UPS
- ◆ Battery Charger
- ◆ DC Motor Power Supply
- ◆ Monitor Power Supply
- ◆ Telecom System Power Supply
- ◆ Distributed Power

## PIN CONFIGURATION

SOP-16 (S16) / PDIP-16 (P16)

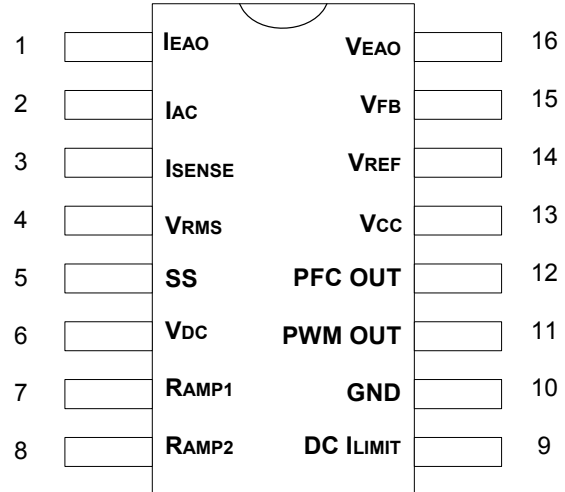

## PIN DESCRIPTION

Pin No.	Symbol	Description	Operating Voltage			
			Min.	Typ.	Max.	Unit
1	IEAO	PFC transconductance current error amplifier output (Gmi).	0		VREF	V
2	IAC	IAC has 2 functions: 1. PFC gain modulator reference input. 2. At start up, IAC is connected to VCC and it helps to reduce the startup time and it helps to reduce the no load consumption. Typical RAC resistor is about 6 Mega ohm to sense the line.	0		100	uA
3	ISENSE	PFC Current Sense: for both Gain Modulator and PFC ILIMIT comparator.	-1.2		0.7	V
4	VRMS	Line Input Sense pin and also, it is the brown out sense pin.	0		VCC+0.3	V
5	SS	Soft start capacitor pin; can use it to on/off the boost follower function; it is pulled down by 300 ohm internal resistor when DCILIMIT reach 1V; the power is limited during the PWM Brown out.	0		10	V



# CM6802A/B/AH/BH (Dynamic Soft PFC/Green PWM)

<http://www.championmicro.com.tw>

EPA/80++ ZVS-Like PFC/PWM COMBO CONTROLLER

Design for High Efficient Power Supply at both Full Load and Light Load

6	V <sub>DC</sub>	DC to DC PWM voltage feedback input.	0		10	V
7	RAMP 1 (RTCT)	Oscillator timing node; timing set by RT and CT	0.8		4	V
8	RAMP 2 (PWM RAMP)	In current mode, this pin functions as the current sense input; when in voltage mode, it is the feed-forward sense input from PFC output 380V (feed forward ramp).	0		V <sub>DCmax</sub> -1.8	V
9	DC I <sub>LIMIT</sub>	PWM current limit comparator input	0		1	V
10	GND	Ground				
11	PWM OUT	PWM driver output	0		VCC	V
12	PFC OUT	PFC driver output	0		VCC	V
13	V <sub>CC</sub>	Positive supply for CM6802A/B/AH/BH	10	15	18	V
14	VREF	Maximum 4mA buffered output for the internal 7.5V reference when VCC=14V		7.5		V
15	V <sub>FB</sub>	PFC transconductance voltage error amplifier input	0	2.5	3	V
16	VEAO	PFC transconductance voltage error amplifier output (GmV)	0		6	V

## ORDERING INFORMATION

Part Number	Temperature Range	Package
CM6802A/B/AH/BHGIP*	-40°C to 125°C	16-Pin PDIP (P16)
CM6802A/B/AH/BHGIS*	-40°C to 125°C	16-Pin Narrow SOP (S16)
CM6802A/B/AH/BHGISTR*	-40°C to 125°C	16-Pin Narrow SOP (S16)
CM6802A/B/AH/BHXIP*	-40°C to 125°C	16-Pin PDIP (P16)
CM6802A/B/AH/BHXIS*	-40°C to 125°C	16-Pin Narrow SOP (S16)
CM6802A/B/AH/BHXISTR*	-40°C to 125°C	16-Pin Narrow SOP (S16)

\*Note: G : Suffix for Pb Free Product

TR : Package is Typing Reel

X : Suffix for Halogen Free Product

## Simplified Block Diagram (CM6802A/B/AH/BH)

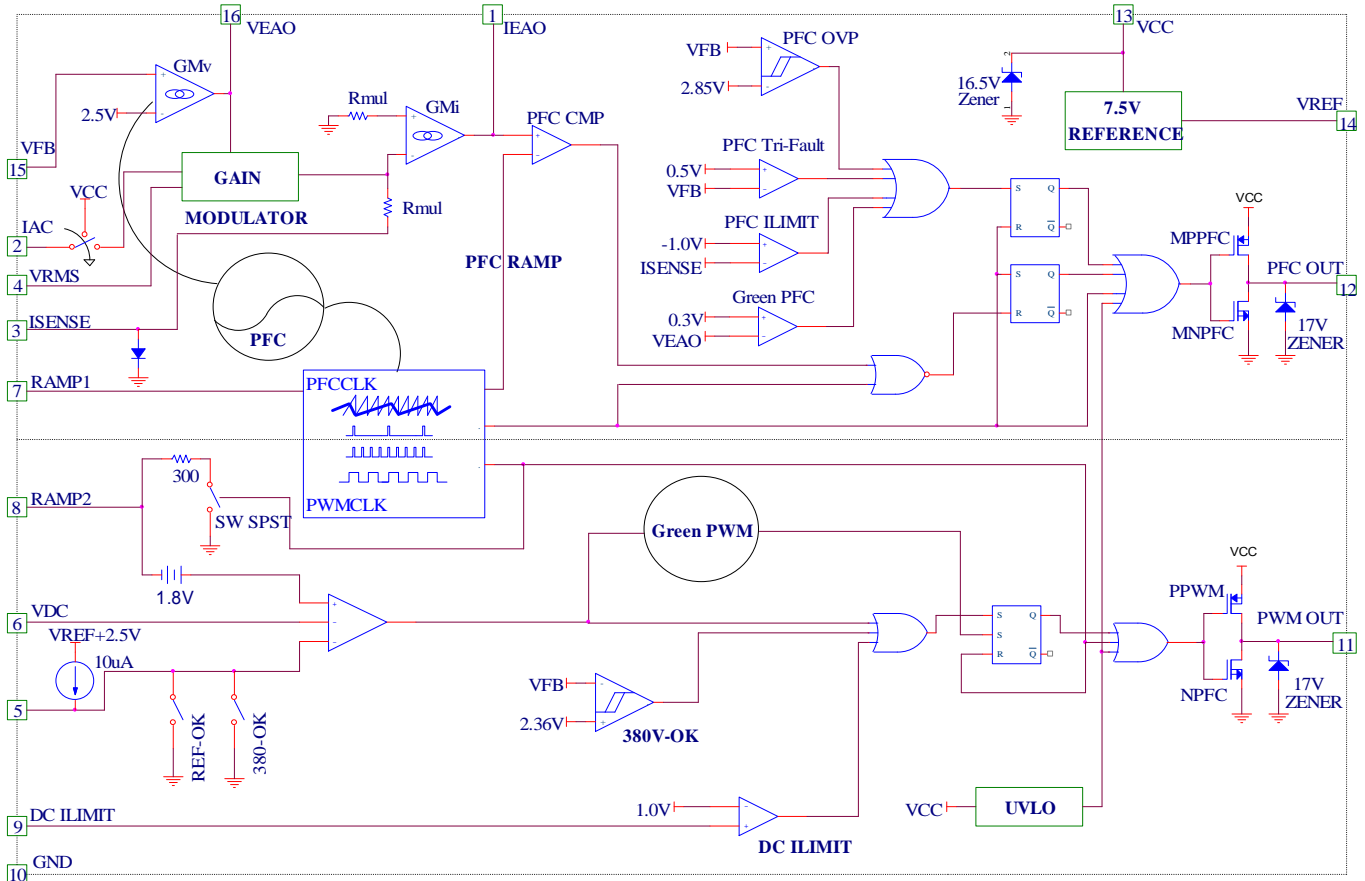

## ABSOLUTE MAXIMUM RATINGS

Absolute Maximum ratings are those values beyond which the device could be permanently damaged.

Parameter	Min.	Max.	Units
V <sub>CC</sub>		18	V
IEAO	0	VREF+0.3	V
I <sub>SENSE</sub> Voltage	-5	0.7	V
PFC OUT	GND - 0.3	VCC + 0.3	V
PWMOUT	GND - 0.3	VCC + 0.3	V
Voltage on Any Other Pin	GND - 0.3	VCC + 0.3	V
I <sub>REF</sub>		5	mA
I <sub>AC</sub> Input Current		1	mA
Peak PFC OUT Current, Source or Sink		0.5	A
Peak PWM OUT Current, Source or Sink		0.5	A
PFC OUT, PWM OUT Energy Per Cycle		1.5	μJ
Junction Temperature		150	°C
Storage Temperature Range	-65	150	°C
Operating Temperature Range	-40	125	°C
Lead Temperature (Soldering, 10 sec)		260	°C
Thermal Resistance (θ <sub>JA</sub> )			
Plastic DIP		80	°C/W
Plastic SOIC		105	°C/W
Power Dissipation (PD) T <sub>A</sub> <50°C		800	mW
ESD Capability, HBM Model		5.5	KV
ESD Capability, CDM Model		1250	V



# CM6802A/B/AH/BH (Dynamic Soft PFC/Green PWM)

<http://www.championmicro.com.tw>

EPA/80++ ZVS-Like PFC/PWM COMBO CONTROLLER

Design for High Efficient Power Supply at both Full Load and Light Load

## ELECTRICAL CHARACTERISTICS:

Unless otherwise stated, these specifications apply  $V_{CC}=+14V$ ,  $R_T = 7.75K \text{ k}\Omega$ ,  $C_T = 1000\text{pF}$ ,  $T_A$ =Operating Temperature Range (Note 1)

Symbol	Parameter	Test Conditions	CM6802A/B/AH/BH			Unit
			Min.	Typ.	Max.	
<b>PFC Brown Out</b>						
	VRMS Threshold High	Room Temperature=25°C	1.19	1.25	1.32	V
	VRMS Threshold Low	Room Temperature=25°C	0.97	1.05	1.13	V
	Hysteresis		170	216	260	mV
	AC High Line	Sweep Vrms Pin	2.15	2.25	2.35	V
	AC Low Line	Sweep Vrms Pin	1.85	2	2.12	V
	Hysteresis		200		300	mV
<b>Voltage Error Amplifier (g<sub>mv</sub>)</b>						
	Input Voltage Range		0		3	V
	Transconductance	$V_{NONINV} = V_{INV}$ , $VEAO = 2.25V @ T=25^\circ C$	53	69	88	$\mu\text{mho}$
	Feedback Reference Voltage (High)	$SS < VREF$ and $Veao > 2.5V$	2.43	2.51	2.58	V
	Feedback Reference Voltage (Low)	<b>CM6802A/B</b> $SS > VREF$ and $Veao <$	1.9	2	2.1	V
		<b>CM6802AH/BH</b> $1.75V$ and $Vrms < 2V$	2.19	2.26	2.33	V
	Input Bias Current	Note 2	-1.0	-0.05		$\mu A$
	Output High Voltage		5.8	6.0		V
	Output Low Voltage			0.1	0.4	V
	Sink Current	$V_{FB} = 3V$ , $VEAO = 1.5V$	-25	-18	-12	$\mu A$
	Source Current	$V_{FB} = 1.5V$ , $VEAO = 2.45V$	8	15	25	$\mu A$
	Open Loop Gain	DC gain	30	40		dB
	Power Supply Rejection Ratio	$11V < V_{CC} < 16.5V$	60	75		dB
<b>Current Error Amplifier (g<sub>mi</sub>)</b>						
	Input Voltage Range (Isense pin)		-1.2		0.7	V
	Transconductance	$V_{NONINV} = V_{INV}$ , $IEAO = 1.5V @ T=25^\circ C$	53	69	85	$\mu\text{mho}$
	Input Offset Voltage	$VEAO=0V$ , IAC is open	-10		50	mV
	Output High Voltage		6.8	7.4	7.7	V
	Output Low Voltage			0.1	0.4	V



# CM6802A/B/AH/BH (Dynamic Soft PFC/Green PWM)

<http://www.championmicro.com.tw>

EPA/80++ ZVS-Like PFC/PWM COMBO CONTROLLER

Design for High Efficient Power Supply at both Full Load and Light Load

## ELECTRICAL CHARACTERISTICS:

(Conti.) Unless otherwise stated, these specifications apply  $V_{CC}=+14V$ ,  $R_T = 7.75\text{ k}\Omega$ ,  $C_T = 1000\text{pF}$ ,  $T_A$ =Operating Temperature Range (Note 1)

Symbol	Parameter	Test Conditions	CM6802A/B/AH/BH			Unit
			Min.	Typ.	Max.	
	Sink Current	$I_{SENSE} = -0.5V$ , IEAO = 1.5V	-42	-33	-30	$\mu A$
	Source Current	$I_{SENSE} = +0.5V$ , IEAO = 4.0V	28	31	42	$\mu A$
	Open Loop Gain	DC Gain	30	40		dB
	Power Supply Rejection Ratio	$11V < V_{CC} < 16.5V$	60	75		dB
<b>PFC OVP Comparator</b>						
	Threshold Voltage		2.70	2.85	3.0	V
	Hysteresis		200		300	mV
<b>PFC Green Power Detect Comparator</b>						
	Veao Threshold Voltage		0.15	0.25	0.35	V
<b>Tri-Fault Detect</b>						
	Fault Detect HIGH		2.70	2.85	3.0	V
	Time to Fault Detect HIGH	$V_{FB}=V_{FAULT\ DETECT\ LOW}$ to $V_{FB}=OPEN$ , 470pF from $V_{FB}$ to GND		2	4	ms
	Fault Detect LOW		0.4	0.5	0.6	V
<b>PFC <math>I_{LIMIT}</math> Comparator</b>						
	Threshold Voltage		-1.10	-1.00	-0.90	V
	( $PFC I_{LIMIT}$ - Gain Modulator Output)		100	200		mV
	Delay to Output (Note 4)	Overdrive Voltage = -100mV		700		ns
<b>DC <math>I_{LIMIT}</math> Comparator</b>						
	Threshold Voltage		0.92	1.0	1.08	V
	Delay to Output (Note 4)	Overdrive Voltage = 100mV		700		ns
<b>DC to DC PWM Brown Out Comparator</b>						
	OK Threshold Voltage		2.20	2.36	2.52	V
	Hysteresis		900	950	1000	mV



# CM6802A/B/AH/BH (Dynamic Soft PFC/Green PWM)

<http://www.championmicro.com.tw>

EPA/80++ ZVS-Like PFC/PWM COMBO CONTROLLER

Design for High Efficient Power Supply at both Full Load and Light Load

## ELECTRICAL CHARACTERISTICS:

(Conti.) Unless otherwise stated, these specifications apply  $V_{CC}=+14V$ ,  $R_T = 7.75\text{ k}\Omega$ ,  $C_T = 1000\text{pF}$ ,  $T_A$ =Operating Temperature Range (Note 1)

Symbol	Parameter	Test Conditions	CM6802A/B/AH/BH			Unit
			Min.	Typ.	Max.	
<b>GAIN Modulator</b>						
	Gain1 (Note 3)	$I_{AC} = 20\text{ }\mu\text{A}$ , $V_{RMS} = 1.125$ , $V_{FB} = 2.375V$ @ $T=25^\circ\text{C}$ SS<VREF	4.5	5	6	
	Gain2 (Note 3)	$I_{AC} = 20\text{ }\mu\text{A}$ , $V_{RMS} = 1.45588V$ , $V_{FB} = 2.375V$ @ $T=25^\circ\text{C}$ SS<VREF	4.2	4.65	5.1	
	Gain3 (Note 3)	$I_{AC} = 20\text{ }\mu\text{A}$ , $V_{RMS} = 2.91V$ , $V_{FB} = 2.375V$ @ $T=25^\circ\text{C}$ SS<VREF	1.45		1.75	
	Gain4 (Note 3)	$I_{AC} = 20\text{ }\mu\text{A}$ , $V_{RMS} = 3.44V$ , $V_{FB} = 2.375V$ @ $T=25^\circ\text{C}$ SS<VREF	1.0		1.45	
	Bandwidth (Note 4)	$I_{AC} = 40\text{ }\mu\text{A}$		1		MHz
	Output Voltage = $R_{mul} * (I_{SENSE} - I_{OFFSET})$	$I_{AC} = 50\text{ }\mu\text{A}$ , $V_{RMS} = 1.125V$ , $V_{FB} = 2.0V$ SS<VREF	0.7	0.78	0.87	V
<b>Oscillator (Measuring fpfc)</b>						
	Initial fpfc Accuracy 1	$R_T = 7.75\text{ k}\Omega$ , $C_T = 1000\text{pF}$ , $T_A = 25^\circ\text{C}$ $I_{AC}=0\text{ }\mu\text{A}$	51	55.5	60	kHz
	Voltage Stability	$11V < V_{CC} < 16.5V$		2		%
	Temperature Stability			2		%
	Total Variation	Line, Temp	48		62	kHz
	Ramp Valley to Peak Voltage	$VEAO=6V$ and $I_{AC}=20\text{ }\mu\text{A}$		2.5		V
	PFC Dead Time (Note 4)		500		900	ns
	CT Discharge Current	$V_{RAMP2} = 0V$ , $V_{RAMP1} = 2.5V$	10	11	12	mA
<b>Light Load Veao Threshold</b>						
	Light Load Threshold (High)	Room Temperature= $25^\circ\text{C}$	2.325	2.50	2.658	V
	Light Load Threshold (Low)	Room Temperature= $25^\circ\text{C}$	1.625	1.75	1.88	V
	Hysteresis		700		850	mV



# CM6802A/B/AH/BH (Dynamic Soft PFC/Green PWM)

<http://www.championmicro.com.tw>

EPA/80++ ZVS-Like PFC/PWM COMBO CONTROLLER

Design for High Efficient Power Supply at both Full Load and Light Load

## ELECTRICAL CHARACTERISTICS

(Conti.) Unless otherwise stated, these specifications apply  $V_{CC}=+14V$ ,  $R_T = 7.75k\Omega$ ,  $C_T = 1000pF$ ,  $T_A=$ Operating Temperature Range (Note 1)

Symbol	Parameter	Test Conditions	CM6802A/B/AH/BH			Unit
			Min.	Typ.	Max.	
<b>Reference</b>						
	Output Voltage	$T_A = 25^\circ C$ , $I(VREF) = 0mA$	7.3	7.5	7.7	V
	Line Regulation	$11V < V_{CC} < 16.5V @ T=25^\circ C$		3	5	mV
	Load Regulation	$V_{CC}=10.5V, 0mA < I(VREF) < 2mA$ ; @ $T=25^\circ C$		25	50	mV
		$V_{CC}=14V, 0mA < I(VREF) < 3.5mA$ ; $T_A = -40^\circ C \sim 85^\circ C$		25	50	mV
	Temperature Stability			0.4		%
	Total Variation	Line, Load, Temp	7.2		7.8	V
	Long Term Stability	$T_J = 125^\circ C$ , 1000HRs	5		25	mV
<b>PFC</b>						
	Minimum Duty Cycle	$I_{EAO} > 4.5V$			0	%
	Maximum Duty Cycle	$V_{IEAO} < 1.2V$	95	97		%
	Output Low Rdson	$I_{OUT} = -20mA @ T=25^\circ C$		11.5	15	ohm
		$I_{OUT} = -100mA @ T=25^\circ C$			18	ohm
		$I_{OUT} = 10mA, V_{CC} = 9V @ T=25^\circ C$		0.5	1	V
	Output High Rdson	$I_{OUT} = 20mA @ T=25^\circ C$		24	30	ohm
		$I_{OUT} = 100mA @ T=25^\circ C$			40	ohm
	Rise/Fall Time (Note 4)	$C_L = 100pF @ T=25^\circ C$		50		ns
<b>PWM</b>						
	Duty Cycle Range		0-49.5		0-50	%
	Output Low Rdson	$I_{OUT} = -20mA @ T=25^\circ C$		11.5	15	ohm
		$I_{OUT} = -100mA @ T=25^\circ C$			18	ohm
		$I_{OUT} = 10mA, V_{CC} = 9V$		0.5	1	V
	Output High Rdson	$I_{OUT} = 20mA @ T=25^\circ C$		26.5	40	ohm
		$I_{OUT} = 100mA @ T=25^\circ C$			40	ohm
	Rise/Fall Time (Note 4)	$C_L = 100pF$		50		ns
	PWM Comparator Level Shift		1.6	1.8	2	V
<b>Soft Start</b>						
	Soft Start Current	Room Temperature= $25^\circ C$	7	8.5	10.5	$\mu A$
<b>Supply</b>						
	Start-Up Current	$V_{CC} = 12V, C_L = 0 @ T=25^\circ C$		50	65	$\mu A$
	Operating Current	$14V, C_L = 0$		2.5	3.5	mA
	Undervoltage Lockout Threshold	CM6802A/B/AH/BH	12.35	12.85	13.45	V
	Undervoltage Lockout Hysteresis	CM6802A/B/AH/BH	2.8	2.95	3.1	V
<b>Shunt Regulator (VCC zener)</b>						
	Zener Threshold Voltage	Apply VCC with $I_{op}=20mA$	16.2	16.8	17.4	V

Note 1: Limits are guaranteed by 100% testing, sampling, or correlation with worst-case test conditions.

Note 2: Includes all bias currents to other circuits connected to the  $V_{FB}$  pin.

Note 3: Gain  $\sim K \times 5.3V$ ;  $K = (I_{SENSE} - I_{OFFSET}) \times [I_{AC} (VEAO - 0.7)]^{-1}$ ;  $VEAO_{MAX} = 6V$

Note 4: Guaranteed by design, not 100% production test.

### TYPICAL PERFORMANCE CHARACTERISTIC:

#### PFC Soft Diagram :

Dynamic Soft PFC Performance @ Vin=110 Vac

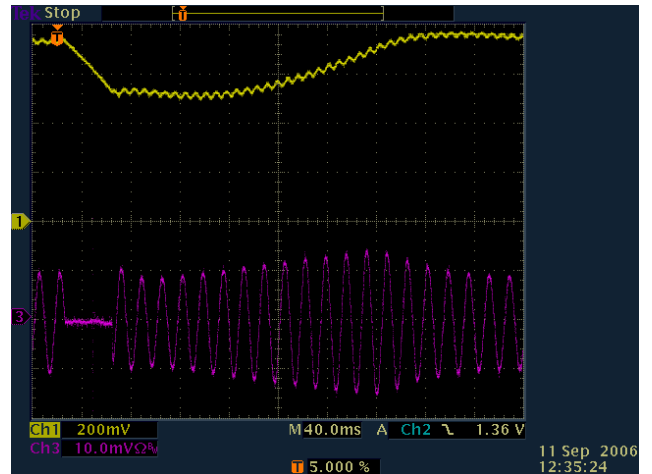
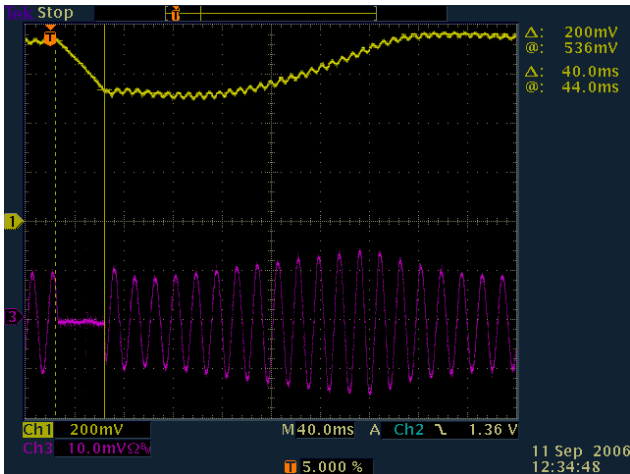

Ch1 is 380V bulk cap voltage which is 100V/div.

Ch3 is Input Line Current which is 1A/div.

Input Line Voltage (110 Vac) was turned off for 40mS before reaching PWM Brownout which is 209Vdc. When the bulk cap voltage goes below 209V, the system will reset the PWM soft start. The result of the CM6802A/B/AH/BH Input Line Current has a clean Off and softly On even the system does not reset PWM soft-start.

Dynamic Soft PFC Performance @ Vin=220 Vac

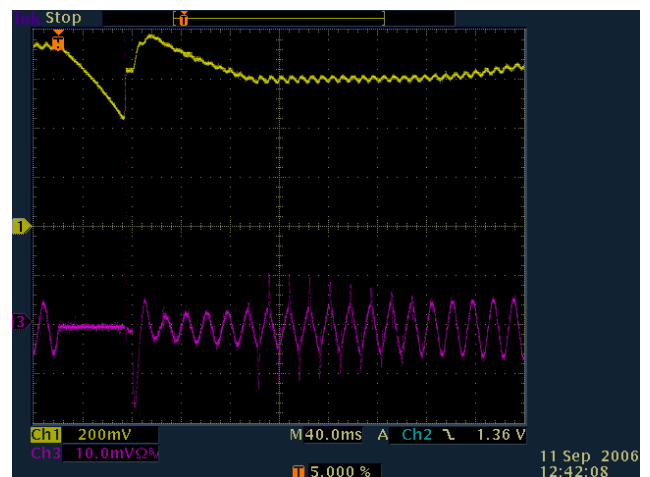
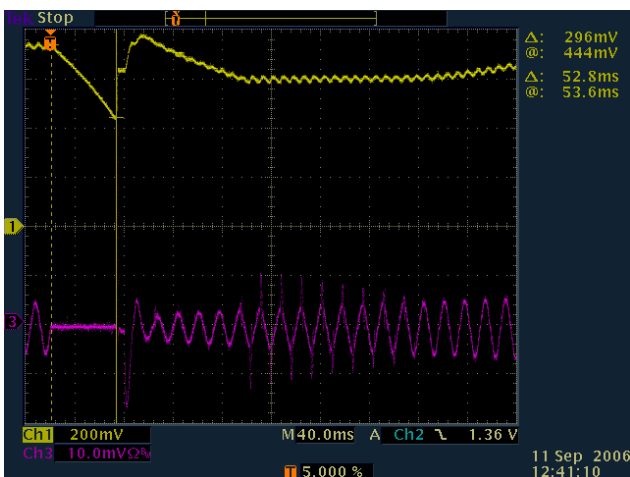

Ch1 is 380V bulk cap voltage which is 100V/div.

Ch3 is Input Line Current which is 1A/div.

Input Line Voltage (220 Vac) was turned off for 40mS before reaching PWM Brownout which is 209Vdc when Bulk cap voltage drops below 209V. When the bulk cap voltage goes below 209V, the system will reset the PWM soft start. The result of the CM6802A/B/AH/BH Input Line Current has a clean Off and softly On even the system does not reset itself. The first peak current at the beginning of the On time is the inrush current.



# CM6802A/B/AH/BH (Dynamic Soft PFC/Green PWM)

<http://www.championmicro.com.tw>

EPA/80++ ZVS-Like PFC/PWM COMBO CONTROLLER

Design for High Efficient Power Supply at both Full Load and Light Load

## Turn on Timing :

Output 50% and 100% load turn on waveform at 110Vac

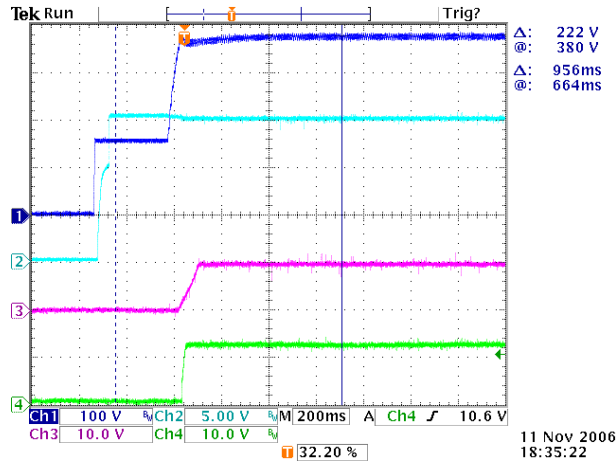

Ch1 is 380V bulk cap voltage which is 100V/div. Ch2 is VCC, Ch3 is SS(soft start pin), CH4 is Vo(12V).

Output 10% and 20% load turn on waveform at 230Vac

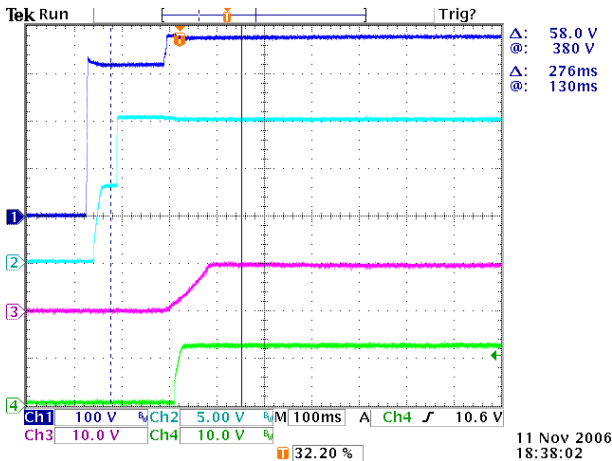

Ch1 is 380V bulk cap voltage which is 100V/div. Ch2 is VCC, Ch3 is SS(soft start pin), CH4 is Vo(12V)

Output 50% and 100% load turn on waveform at 230Vac

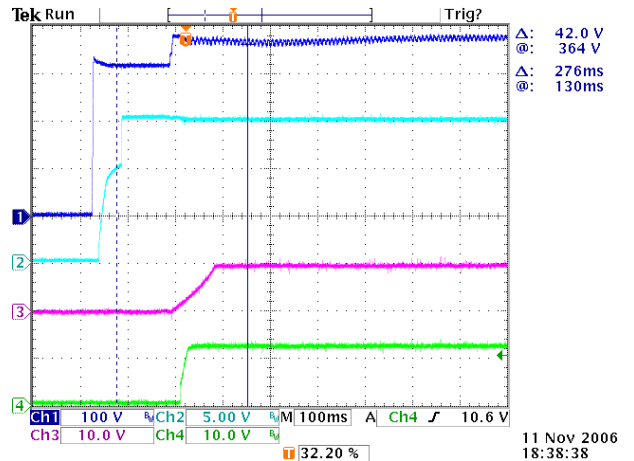

Ch1 is 380V bulk cap voltage which is 100V/div. Ch2 is VCC, Ch3 is SS(soft start pin), CH4 is Vo(12V)

## Dynamic load:

Output step load 10% to 100% load at 90Vac

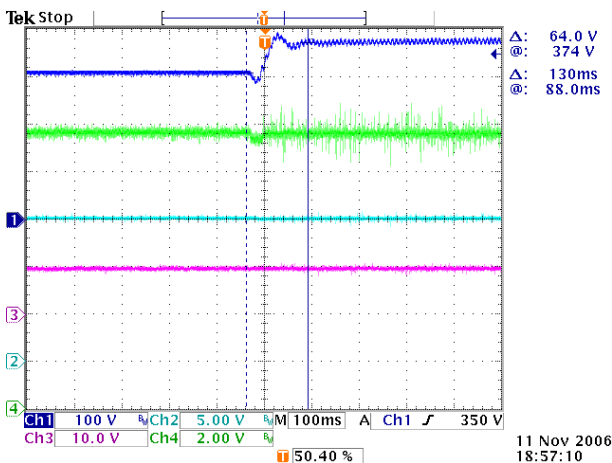

Ch1 is 380V bulk cap voltage which is 100V/div. Ch2 is VCC, Ch3 is SS(soft start pin), CH4 is Vo(12V)

Output step 100% load to 10% load at 90Vac

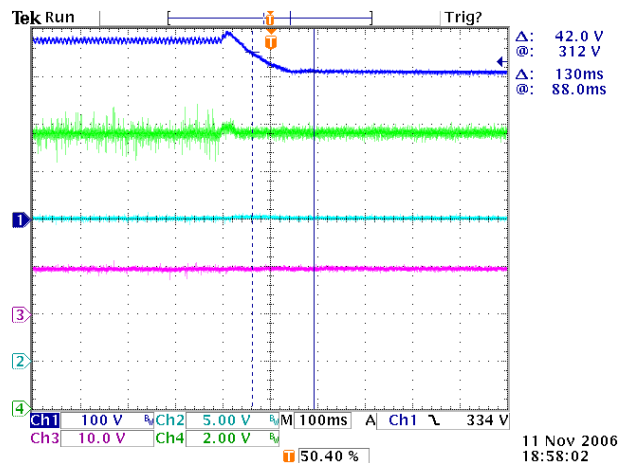

Ch1 is 380V bulk cap voltage which is 100V/div. Ch2 is VCC, Ch3 is SS(soft start pin), CH4 is Vo(12V)



# CM6802A/B/AH/BH (Dynamic Soft PFC/Green PWM)

<http://www.championmicro.com.tw>

## EPA/80++ ZVS-Like PFC/PWM COMBO CONTROLLER

### Design for High Efficient Power Supply at both Full Load and Light Load

#### Output step load 10% to 100% load at 230Vac

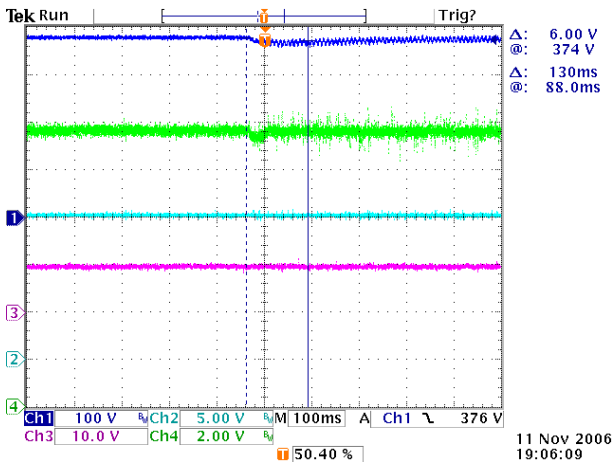

Ch1 is 380V bulk cap voltage which is 100V/div.  
Ch2 is VCC, Ch3 is SS (soft start pin), Ch4 is Vo(12V)

#### Output step 100% load to 10% load at 230Vac

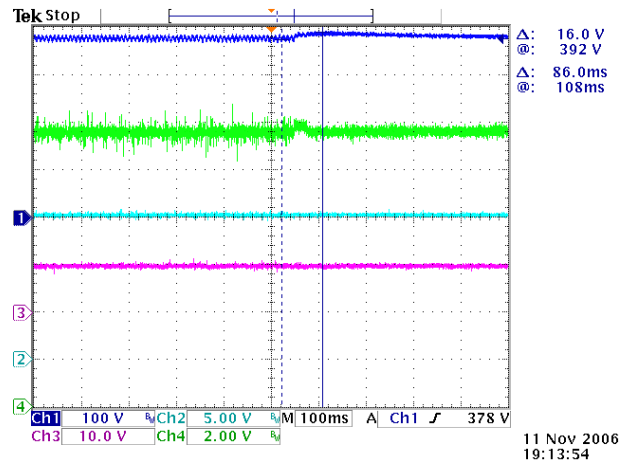

Ch1 is 380V bulk cap voltage which is 100V/div.  
Ch2 is VCC, Ch3 is SS (soft start pin), Ch4 is Vo(12V)

## AC power cycling :

### 90VAC turn on 500ms turn off 100ms at 10%LOAD

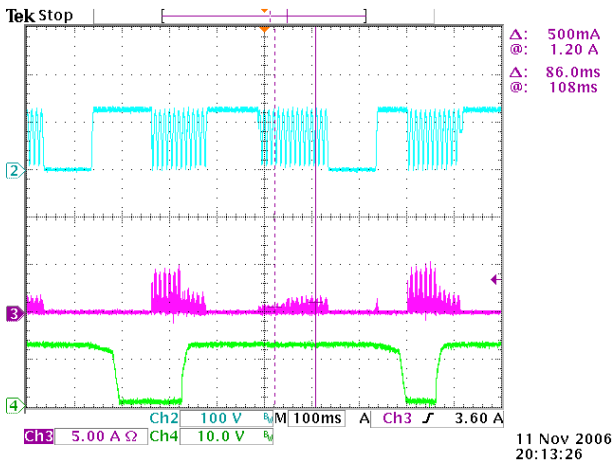

Ch2 is AC input voltage which is 100V/div.  
Ch3 is PFC stage Mosfet drain current, Ch4 is Vo(12V)

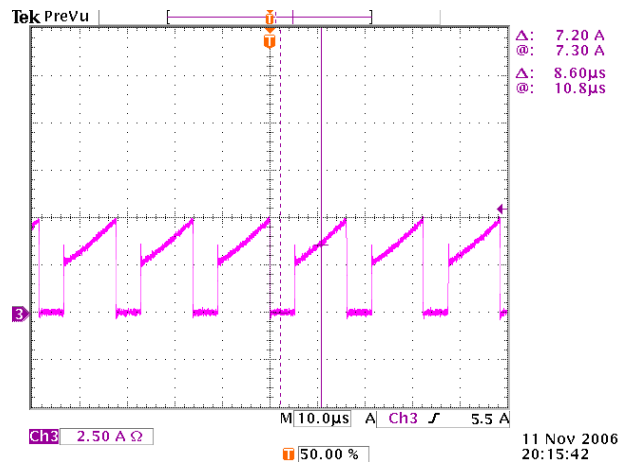

Ch3 is PFC stage Mosfet Drain current (zoom out)

### 90VAC turn on 500ms turn off 100ms at 100%LOAD

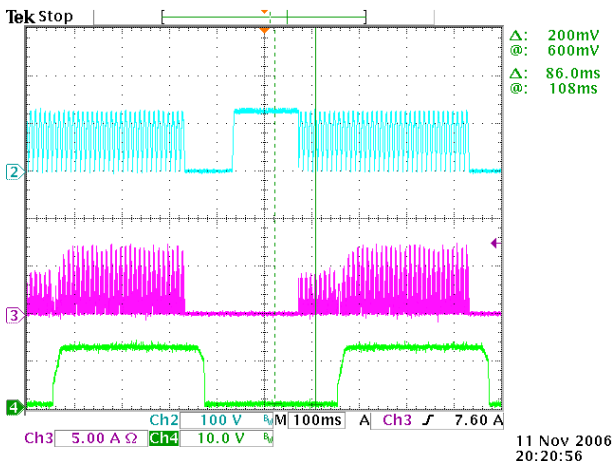

Ch2 is AC input voltage which is 100V/div.  
Ch3 is PFC stage Mosfet drain current, Ch4 is Vo(12V)

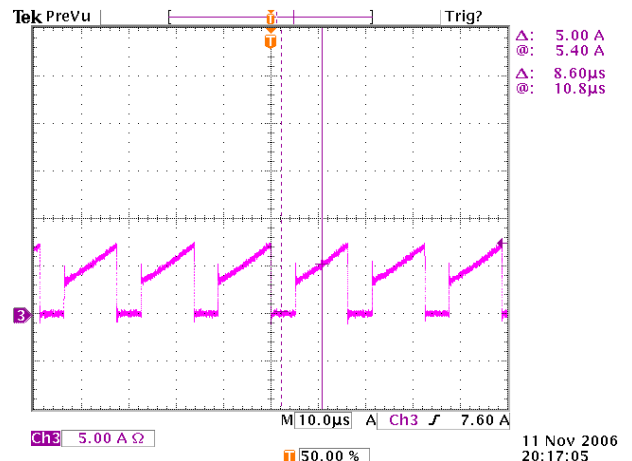

Ch3 is PFC stage Mosfet Drain current (zoom out)

#### 90VAC turn on 500ms turn off 10ms at 10%LOAD

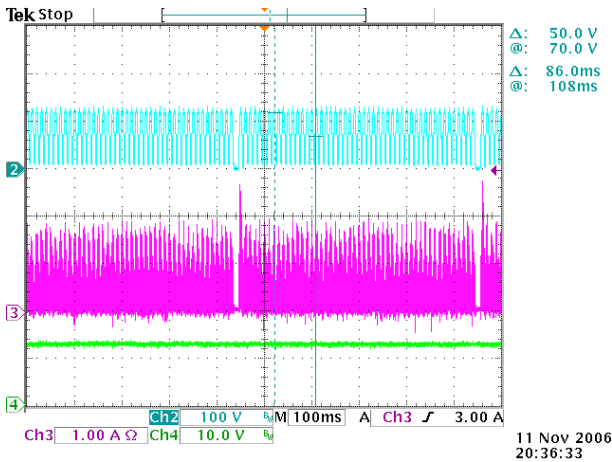

Ch2 is AC input voltage which is 100V/div.  
Ch3 is PFC stage Mosfet drain current, CH4 is Vo (12V)

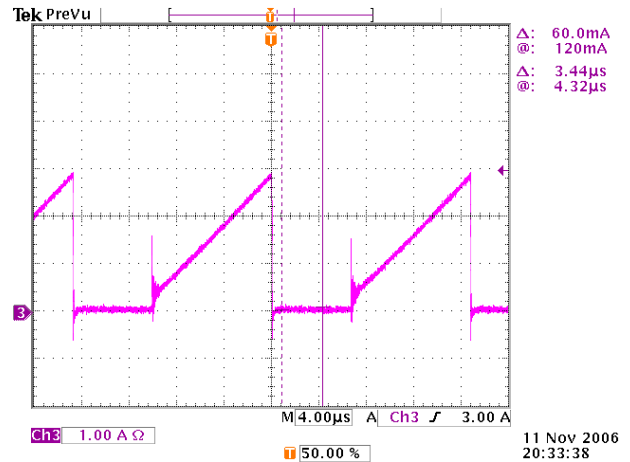

Ch3 is PFC stage Mosfet Drain current (zoom out)

#### 90VAC turn on 500ms turn off 10ms at 100%LOAD

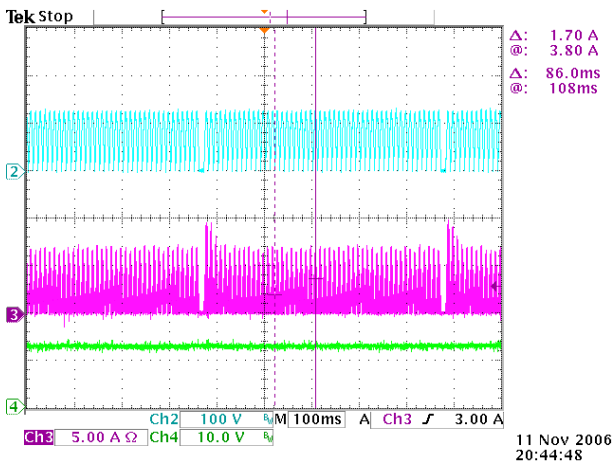

Ch2 is AC input voltage which is 100V/div.  
Ch3 is PFC stage Mosfet drain current, CH4 is Vo (12V)

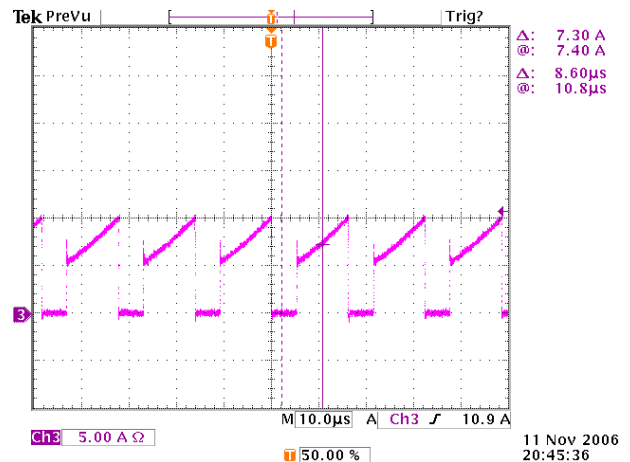

Ch3 is PFC stage Mosfet Drain current (zoom out)

#### 230VAC turn on 500ms turn off 100ms at 10%LOAD

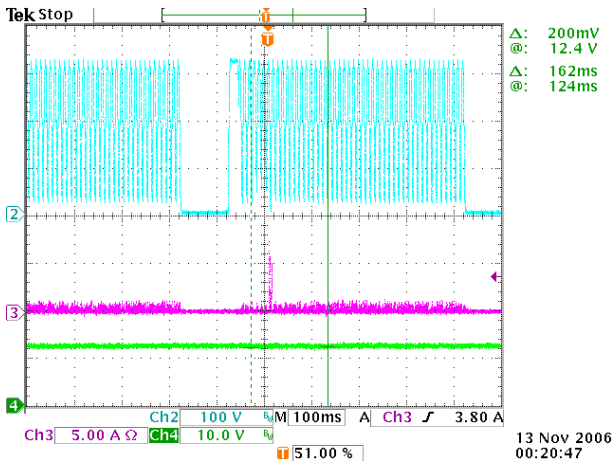

Ch2 is AC input voltage which is 100V/div.  
Ch3 is PFC stage Mosfet drain current, CH4 is Vo (12V)

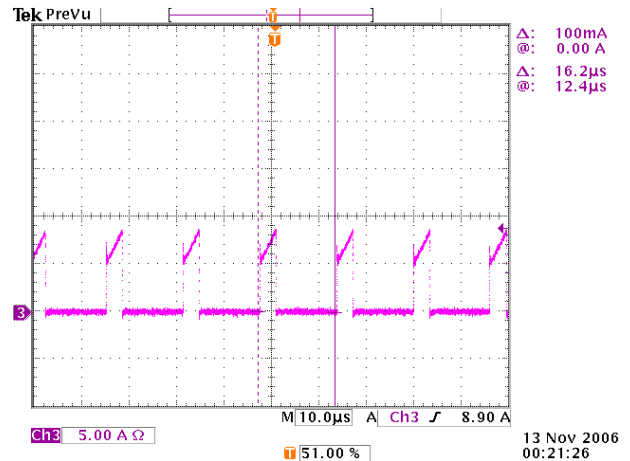

Ch3 is PFC stage Mosfet Drain current (zoom out)

#### 230VAC turn on 500ms turn off 100ms at 100%LOAD

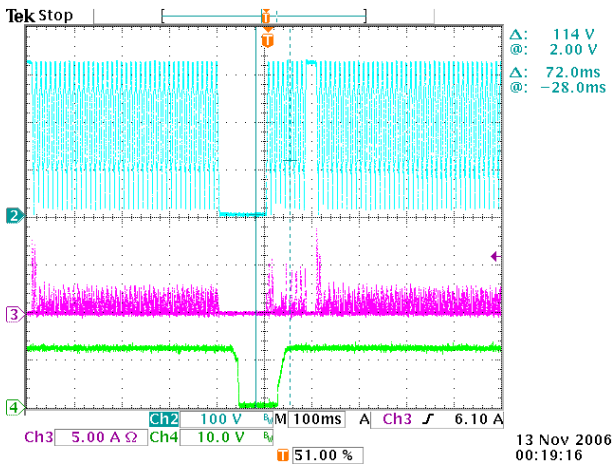

Ch2 is AC input voltage which is 100V/div.  
Ch3 is PFC stage Mosfet drain current, CH4 is Vo (12V)

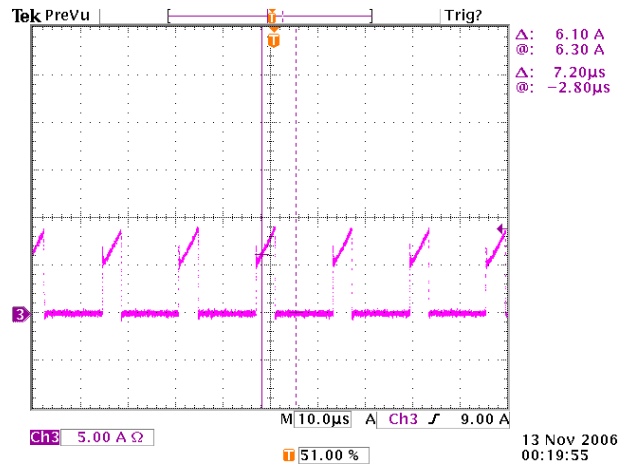

Ch3 is PFC stage Mosfet Drain current (zoom out)

#### 230VAC turn on 500ms turn off 10ms at 10%LOAD

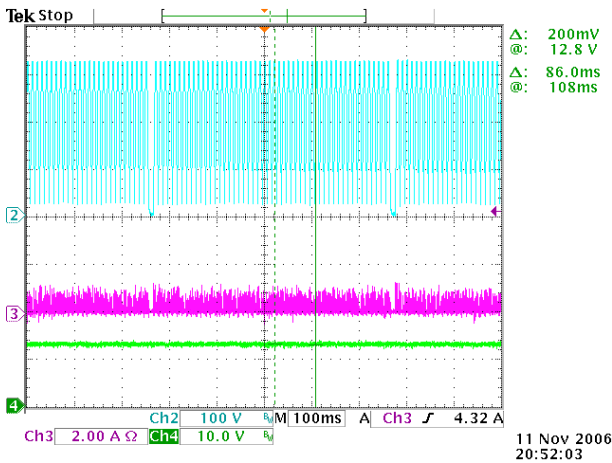

Ch2 is AC input voltage which is 100V/div.  
Ch3 is PFC stage Mosfet drain current, CH4 is Vo (12V)

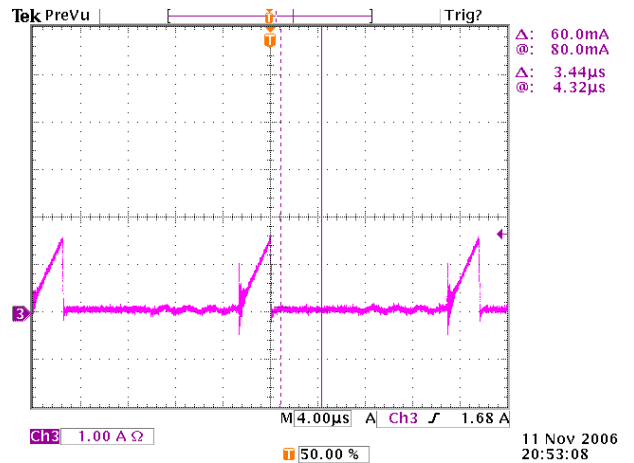

Ch3 is PFC stage Mosfet Drain current (zoom out)

#### 230VAC turn on 500ms turn off 10ms at 100%LOAD

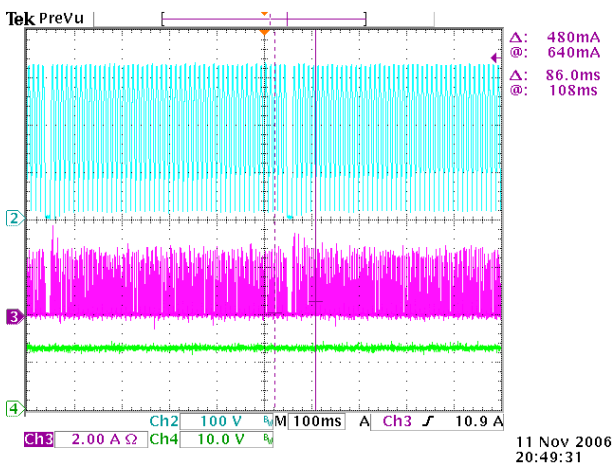

Ch2 is AC input voltage which is 100V/div.  
Ch3 is PFC stage Mosfet drain current, CH4 is Vo (12V)

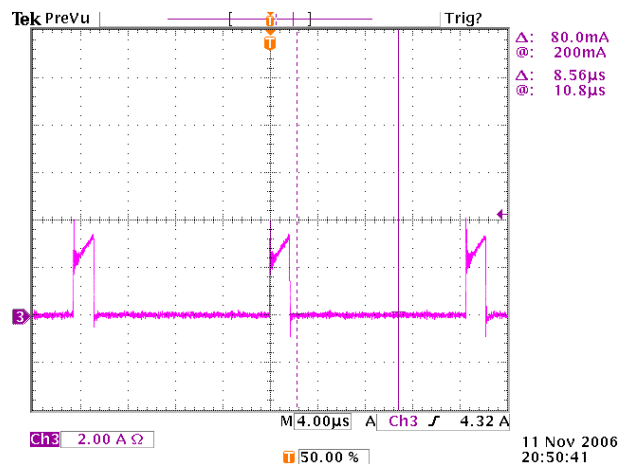

Ch3 is PFC stage Mosfet Drain current (zoom out)



# CM6802A/B/AH/BH (Dynamic Soft PFC/Green PWM)

<http://www.championmicro.com.tw>

EPA/80++ ZVS-Like PFC/PWM COMBO CONTROLLER

Design for High Efficient Power Supply at both Full Load and Light Load

## Getting Start:

To start evaluating CM6802A/B/AH/BH from the existing CM6800 or ML4800 board, 6 things need to be taken care before doing the fine tune:

- 1.) Change RAC resistor (on pin 2, IAC) from the old value to a higher resistor value between 4.7 Mega ohms to 8 Mega ohms.
- 2.) Change RTCT pin (pin 7) from the existing value to  $RT=7.0K$  ohm and  $CT=1000pF$  to have  $f_{pfc}=55$  KHz,  $f_{pwm}=55$  KHz,  $f_{RTCT}=220$  KHz for CM6802A/AH and  $f_{pfc}=55$  KHz,  $f_{pwm}=110$  KHz,  $f_{RTCT}=220$  KHz for CM6802B/BH.
- 3.) Adjust all high voltage resistor around 5 mega ohm or higher.
- 4.) VRMS pin (pin 4) needs to be 1.125V at  $V_{IN}=85VAC$  for universal input application from line input from 85VAC to 270VAC. Both poles for the Vrms of the CM6802A/B/AH/BH needs to be substantially slow than CM6800 about 5 to 10 times.
- 5.) At full load, the average Veao needs to be around 4.5V and the ripple on the Veao needs to be less than 250mV.
- 6.) Soft Start pin (pin 5), the soft start current has been reduced from CM6800's 20uA to CM6802A/B/AH/BH's 10uA. Soft Start capacitor can be reduced to 1/2 from your original CM6800 capacitor.

## Functional Description

CM6802A/B/AH/BH is designed for high efficient power supply for both full load and light load. It is a popular EPA/80++ PFC-PWM power supply controller.

The CM6802A/B/AH/BH consists of an average current controlled, continuous/discontinuous boost Power Factor Correction (PFC) front end and a synchronized Pulse Width Modulator (PWM) back end. The PWM can be used in either current or voltage mode. In voltage mode, feed-forward from the PFC output bus can be used to improve the PWM's line regulation. In either mode, the PWM stage uses conventional trailing edge duty cycle modulation, while the PFC uses leading edge modulation. This patented leading/trailing edge modulation technique results in a higher usable PFC error amplifier bandwidth, and can significantly reduce the size of the PFC DC buss capacitor.

The synchronization of the PWM with the PFC simplifies the PWM compensation due to the controlled ripple on the PFC output capacitor (the PWM input capacitor).

In addition to power factor correction, a number of protection features have been built into the CM6802A/B/AH/BH. These include soft-start, PFC over-voltage protection, peak current limiting, brownout protection, duty cycle limiting, and under-voltage lockout.

## Power Factor Correction

Power factor correction makes a nonlinear load look like a resistive load to the AC line. For a resistor, the current drawn from the line is in phase with and proportional to the line voltage, so the power factor is unity (one). A common class of nonlinear load is the input of most power supplies, which use a bridge rectifier and capacitive input filter fed from the line. The peak-charging effect, which occurs on the input filter capacitor in these supplies, causes brief high-amplitude pulses of current to flow from the power line, rather than a sinusoidal current in phase with the line voltage. Such supplies present a power factor to the line of less than one (i.e. they cause significant current harmonics of the power line frequency to appear at their input). If the input current drawn by such a supply (or any other nonlinear load) can be made to follow the input voltage in instantaneous amplitude, it will appear resistive to the AC line and a unity power factor will be achieved.

To hold the input current draw of a device drawing power from the AC line in phase with and proportional to the input voltage, a way must be found to prevent that device from loading the line except in proportion to the instantaneous line voltage. The PFC section of the CM6802A/B/AH/BH uses a boost-mode DC-DC converter to accomplish this. The input to the converter is the full wave rectified AC line voltage. No bulk filtering is applied following the bridge rectifier, so the input voltage to the boost converter ranges (at twice line frequency) from zero volts to the peak value of the AC input and back to zero. By forcing the boost converter to meet two simultaneous conditions, it is possible to ensure that the current drawn from the power line is proportional to the input line voltage. One of these conditions is that the output voltage of the boost converter must be set higher than the peak value of the line voltage. A commonly used value is 385VDC, to allow for a high line of 270VAC<sub>rms</sub>. The other condition is that the current drawn from the line at any given instant must be proportional to the line voltage. Establishing a suitable voltage control loop for the converter, which in turn drives a current error amplifier and switching output driver satisfies the first of these requirements. The second requirement is met by using the rectified AC line voltage to modulate the output of the voltage control loop. Such modulation causes the current error amplifier to command a power stage current that varies directly with the input voltage. In order to prevent ripple, which will necessarily appear at the output of boost circuit (typically about 10VAC on a 385V DC level); from introducing distortion back through the voltage error amplifier, the bandwidth of the voltage loop is deliberately kept low. A final refinement is to adjust the overall gain of the PFC such to be proportional to  $1/(V_{in} \times V_{in})$ , which linearizes the transfer function of the system as the AC input to voltage varies.

Since the boost converter topology in the CM6802A/B/AH/BH PFC is of the current-averaging type, no slope compensation is required.

More exactly, the output current of the gain modulator is given by:

#### Dynamic Soft PFC (patent pending)

Besides all the goodies from CM6800A, Dynamic Soft PFC is the main feature of CM6802A/B/AH/BH. Dynamic Soft PFC is to improve the efficiency, to reduce power device stress, to ease EMI, and to ease the monotonic output design while it has the more protection such as the short circuit with power fold back protection. Its unique sequential control maximizes the performance and the protections among steady state, transient and the power on/off conditions.

#### PFC Section:

##### Gain Modulator

Figure 1 shows a block diagram of the PFC section of the CM6802A/B/AH/BH. The gain modulator is the heart of the PFC, as it is this circuit block which controls the response of the current loop to line voltage waveform and frequency, rms line voltage, and PFC output voltages. There are three inputs to the gain modulator. These are:

1. A current representing the instantaneous input voltage (amplitude and wave-shape) to the PFC. The rectified AC input sine wave is converted to a proportional current via a resistor and is then fed into the gain modulator at  $I_{AC}$ . Sampling current in this way minimizes ground noise, as is required in high power switching power conversion environments. The gain modulator responds linearly to this current.
2. A voltage proportional to the long-term RMS AC line voltage, derived from the rectified line voltage after scaling and filtering. This signal is presented to the gain modulator at  $V_{RMS}$ . The gain modulator's output is inversely proportional to  $V_{RMS}^2$  (except at unusually low values of  $V_{RMS}$  where special gain contouring takes over, to limit power dissipation of the circuit components under heavy brownout conditions). The relationship between  $V_{RMS}$  and gain is called K, and is illustrated in the Typical Performance Characteristics.
3. The output of the voltage error amplifier, VEAO. The gain modulator responds linearly to variations in this voltage.

The output of the gain modulator is a current signal, in the form of a full wave rectified sinusoid at twice the line frequency. This current is applied to the virtual-ground (negative) input of the current error amplifier. In this way the gain modulator forms the reference for the current error loop, and ultimately controls the instantaneous current draw of the PFC from the power line. The general formula of the output of the gain modulator is:

$$I_{mul} = \frac{I_{AC} \times (VEAO - 0.7V)}{V_{RMS}^2} \times \text{constant} \quad (1)$$

$$\text{Gain} = I_{mul} / I_{ac}$$

$$K = \text{Gain} / (VEAO - 0.7V)$$

$$I_{mul} = K \times (VEAO - 0.7V) \times I_{AC}$$

Where K is in units of  $[V^{-1}]$

Note that the output current of the gain modulator is limited around  $100 \mu A$  and the maximum output voltage of the gain modulator is limited to  $100 \mu A \times 7.75K \approx 0.8V$ . This 0.8V also will determine the maximum input power.

However,  $I_{GAINMOD}$  cannot be measured directly from  $I_{SENSE}$ .  $I_{SENSE} = I_{GAINMOD} - I_{OFFSET}$  and  $I_{OFFSET}$  can only be measured when VEAO is less than 0.5V and  $I_{GAINMOD}$  is 0A. Typical  $I_{OFFSET}$  is around 33uA.

$I_{AC}=20\mu A, Veao=6V$

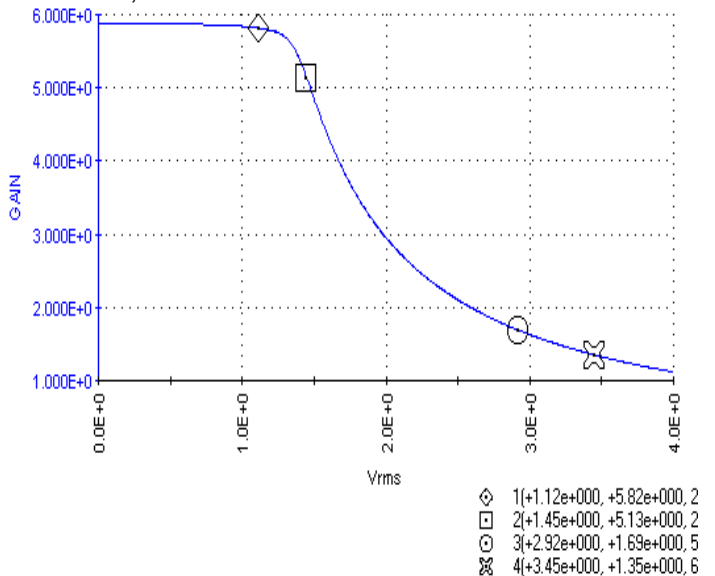

Gain vs. VRMS (pin4)

When  $V_{RMS}$  below 1V, the PFC is shut off. Designer needs to design 85VAC with  $V_{RMS}$  average voltage=1.125V.

$$\text{Gain} = \frac{I_{SENSE} - I_{OFFSET}}{I_{AC}} = \frac{I_{MUL}}{I_{AC}}$$

#### Selecting $R_{AC}$ for IAC pin

IAC pin is the input of the gain modulator. IAC also is a current mirror input and it requires current input. By selecting a proper resistor  $R_{AC}$ , it will provide a good sine wave current derived from the line voltage and it also helps program the maximum input power and minimum input line voltage.

$R_{AC} = V_{in \text{ min peak}} \times 39.09K$ . For example, if the minimum line voltage is 85VAC, the  $R_{AC} = 85 \times 1.414 \times 39.09K = 4.7 \text{ Megaohm}$ .

## Vrms Description:

VRMS pin is designed for the following functions:

1. VRMS is used to detect the AC Brown Out (Also, we can call it PFC brown out.). When VRMS is less than 1.0 V +/-5%, PFCOUT will be turned off and VEAO will be softly discharged toward 0 Volt. When VRMS is greater than 1.25V +/-5%, PFCOUT is enabled and VEAO is released.
2. VRMS also is used to determine if the AC Line is high line or it is low line. If VRMS is above 2.5V +/- 5%, IC will recognize it is high line the. If VRMS is below 2.25V +/- 5%, it is low line. Between 2V <= $\sim$  Vrms <= $\sim$  2.25V, it is the hysteresis.
3. At High Line and Light Load, 380V to 304V (Vfb threshold moves from 2.5V to 2V) is prohibited of CM6802A/B ; 380V to 342V (Vfb threshold moves from 2.5V to 2.25V) is prohibited of CM6802AH/BH.

At Low Line and Light Load, 380V to 304V (Vfb threshold moves from 2.5V to 2V) is enable of CM6802A/B ; 380V to 342V (Vfb threshold moves from 2.5V to 2.25V) is enable of CM6802AH/BH. It provides ZVS-Like performance.

## Current Error Amplifier, IEAO

The current error amplifier's output controls the PFC duty cycle to keep the average current through the boost inductor a linear function of the line voltage. At the inverting input to the current error amplifier, the output current of the gain modulator is summed with a current which results from a negative voltage being impressed upon the I<sub>SENSE</sub> pin. The negative voltage on I<sub>SENSE</sub> represents the sum of all currents flowing in the PFC circuit, and is typically derived from a current sense resistor in series with the negative terminal of the input bridge rectifier.

In higher power applications, two current transformers are sometimes used, one to monitor the IF of the boost diode. As stated above, the inverting input of the current error amplifier is a virtual ground. Given this fact, and the arrangement of the duty cycle modulator polarities internal to the PFC, an increase in positive current from the gain modulator will cause the output stage to increase its duty cycle until the voltage on I<sub>SENSE</sub> is adequately negative to cancel this increased current. Similarly, if the gain modulator's output decreases, the output duty cycle will decrease, to achieve a less negative voltage on the I<sub>SENSE</sub> pin.

## Error Amplifier Compensation

The PWM loading of the PFC can be modeled as a negative resistor; an increase in input voltage to the PWM causes a decrease in the input current. This response dictates the proper compensation of the two transconductance error amplifiers. Figure 2 shows the types of compensation networks most commonly used for the voltage and current error amplifiers, along with their respective return points.

The current loop compensation is returned to V<sub>REF</sub> to produce a soft-start characteristic on the PFC: as the reference voltage comes up from zero volts, it creates a differentiated voltage on I<sub>EAO</sub> which prevents the PFC from immediately demanding a full duty cycle on its boost converter.

## PFC Brown Out (PFC Brown Out Comparator)

The PFC Brown Out comparator monitors the Vrms (pin 4) voltage and inhibits the PFC and PFC error amplifier output, V<sub>eao</sub> is pulled down during the Vrms is lower than threshold. If this voltage on Vrms is less than its nominal 1.25V. Once this voltage reaches 1.25V, which corresponds to the PFC input rms is around 88Vac. It is a hysteresis comparator and its lower threshold is 1V. After PFC Brown Out conditions are removed, the system will initiate the start up sequence with the proper soft start rate set by SS (pin 5).

## Cycle-By-Cycle Current Limiter and Selecting R<sub>SENSE</sub>

The I<sub>SENSE</sub> pin, as well as being a part of the current feedback loop, is a direct input to the cycle-by-cycle current limiter for the PFC section. Should the input voltage at this pin ever be more negative than -1V, the output of the PFC will be disabled until the protection flip-flop is reset by the clock pulse at the start of the next PFC power cycle.

R<sub>s</sub> is the sensing resistor of the PFC boost converter. During the steady state, line input current x R<sub>SENSE</sub> = I<sub>muli</sub> x 7.75K. Since the maximum output voltage of the gain modulator is I<sub>muli</sub> max x 7.75K  $\approx$  0.8V during the steady state, R<sub>SENSE</sub> x line input current will be limited below 0.8V as well. When VEAO reaches maximum VEAO which is 6V, I<sub>sense</sub> can reach 0.8V. At 100% load, VEAO should be around 4.5V and I<sub>SENSE</sub> average peak is 0.6V. It will provide the optimal dynamic response + tolerance of the components.

Therefore, to choose R<sub>SENSE</sub>, we use the following equation:

$$R_{SENSE} + R_{Parasitic} = 0.6V \times V_{inpeak} / (2 \times \text{Line Input power})$$

For example, if the minimum input voltage is 80VAC, and the maximum input rms power is 200Watt, R<sub>SENSE</sub> + R<sub>Parasitic</sub> = (0.6V x 80V x 1.414) / (2 x 200) = 0.169 ohm. The designer needs to consider the parasitic resistance and the margin of the power supply and dynamic response. Assume R<sub>Parasitic</sub> = 30 mOhm, R<sub>SENSE</sub> = 139 mOhm.

## PFC OVP

In the CM6802A/B/AH/BH, PFC OVP comparator serves to protect the power circuit from being subjected to excessive voltages if the load should suddenly change. A resistor divider from the high voltage DC output of the PFC is fed to VFB. When the voltage on VFB exceeds ~ 2.85V, the PFC output driver is shut down. The PWM section will continue to operate. The OVP comparator has 250mV of hysteresis, and the PFC will not restart until the voltage at VFB drops below ~ 2.55V. The VFB power components and the CM6802A/B/AH/BH are within their safe operating voltages, but not so low as to interfere with the boost voltage regulation loop.

### PFC Voltage Loop

There are two major concerns when compensating the voltage loop error amplifier,  $V_{EAO}$ ; stability and transient response. Optimizing interaction between transient response and stability requires that the error amplifier's open-loop crossover frequency should be 1/2 that of the line frequency, or 23Hz for a 47Hz line (lowest anticipated international power frequency).

deviate from its 2.5V (nominal) value. If this happens, the transconductance of the voltage error amplifier,  $GM_V$  will increase significantly, as shown in the Typical Performance Characteristics. This raises the gain-bandwidth product of the voltage loop, resulting in a much more rapid voltage loop response to such perturbations than would occur with a conventional linear gain characteristics.

The Voltage Loop Gain (S)

$$= \frac{\Delta V_{OUT} * \Delta V_{FB} * \Delta V_{EAO}}{\Delta V_{EAO} * \Delta V_{OUT} * \Delta V_{FB}}$$

$$\approx \frac{P_{IN} * 2.5V}{V_{OUTDC}^2 * \Delta V_{EAO} * S * C_{DC}} * GM_V * Z_{CV}$$

$Z_{CV}$ : Compensation Net Work for the Voltage Loop

$GM_V$ : Transconductance of  $V_{EAO}$

$P_{IN}$ : Average PFC Input Power

$V_{OUTDC}$ : PFC Boost Output Voltage; typical designed value is 380V.

$C_{DC}$ : PFC Boost Output Capacitor

### PFC Current Loop

The current transconductance amplifier,  $GM_I$ ,  $I_{EAO}$  compensation is similar to that of the voltage error amplifier,  $V_{EAO}$  with exception of the choice of crossover frequency. The crossover frequency of the

current amplifier should be at least 10 times that of the voltage amplifier, to prevent interaction with the voltage loop. It should also be limited to less than 1/6th that of the switching frequency, e.g. 8.33kHz for a 50kHz switching frequency.

The Current Loop Gain (S)

$$= \frac{\Delta V_{ISENSE} * \Delta D_{OFF} * \Delta I_{EAO}}{\Delta D_{OFF} * \Delta I_{EAO} * \Delta I_{ISENSE}}$$

$$\approx \frac{V_{OUTDC} * R_S}{S * L * 2.5V} * GM_I * Z_{CI}$$

$Z_{CI}$ : Compensation Net Work for the Current Loop

$GM_I$ : Transconductance of  $I_{EAO}$

$V_{OUTDC}$ : PFC Boost Output Voltage; typical designed value is 380V and we use the worst condition to calculate the  $Z_{CI}$

$R_{SENSE}$ : The Sensing Resistor of the Boost Converter

**2.5V**: The Amplitude of the PFC Leading Edge Modulation Ramp(typical)

$L$ : The Boost Inductor

The gain vs. input voltage of the CM6802A/B/AH/BH's voltage error amplifier,  $V_{EAO}$  has a specially shaped non-linearity such that under steady-state operating conditions the transconductance of the error amplifier,  $GM_V$  is at a local minimum. Rapid perturbation in line or load conditions will cause the input to the voltage error amplifier ( $V_{FB}$ ) to

$I_{SENSE}$  Filter, the RC filter between  $R_{SENSE}$  and  $I_{SENSE}$  :

There are 2 purposes to add a filter at  $I_{SENSE}$  pin:

- 1.) Protection: During start up or inrush current conditions, it will have a large voltage cross  $R_S$  which is the sensing resistor of the PFC boost converter. It requires the  $I_{SENSE}$  Filter to attenuate the energy.
- 2.) To reduce  $L$ , the Boost Inductor: The  $I_{SENSE}$  Filter To reduce  $L$ , the Boost Inductor: The  $I_{SENSE}$  Filter also can reduce the Boost Inductor value since the  $I_{SENSE}$  Filter behaves like an integrator before going  $I_{SENSE}$  which is the input of the current error amplifier,  $I_{EAO}$ .

The  $I_{SENSE}$  Filter is a RC filter. The resistor value of the  $I_{SENSE}$  Filter is between 100 ohm and 50 ohm because  $I_{OFFSET} \times$  the resistor can generate an offset voltage of  $I_{EAO}$ . By selecting  $R_{FILTER}$  equal to 50 ohm will keep the offset of the  $I_{EAO}$  less than 5mV. Usually, we design the pole of  $I_{SENSE}$  Filter at  $f_{pfc}/6=8.33Khz$ , one sixth of the PFC switching frequency. Therefore, the boost inductor can be reduced 6 times without disturbing the stability. Therefore, the capacitor of the  $I_{SENSE}$  Filter,  $C_{FILTER}$ , will be around 381nF.

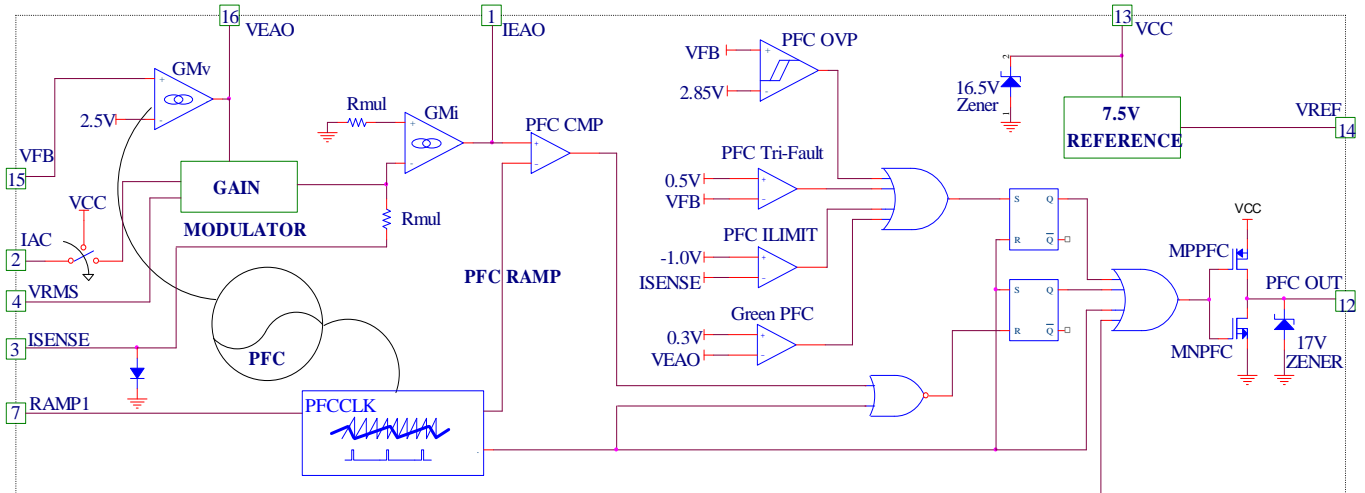

Figure 1. PFC Section Block Diagram

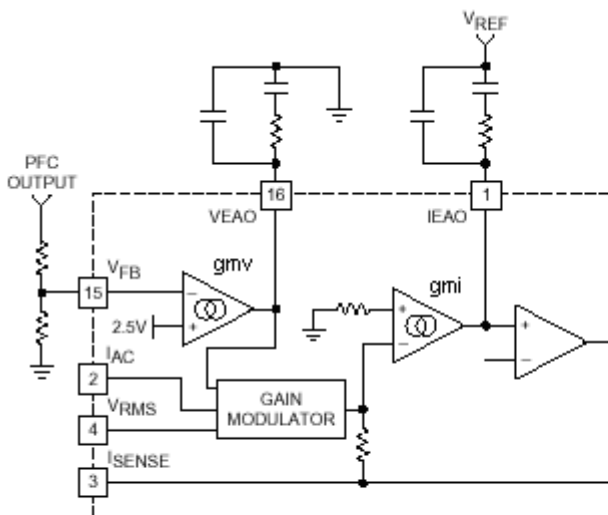

Figure 2. Compensation Network Connections for the Voltage and Current Error Amplifiers

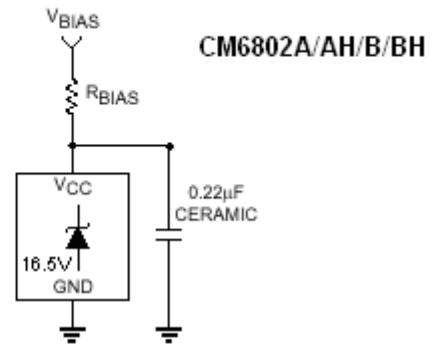

Figure 3. External Component Connections to VCC

## Oscillator (RAMP1, or called RTCT)

In CM6802A/AH,  $f_{RTCT}=4 \times f_{pwm}=4 \times f_{pfc}$   $f_{RTCT}=200\text{Khz}$ ,  $f_{pwm}=50\text{Khz}$  and  $f_{pfc}=50\text{Khz}$  when  $V_{EAO}=0\text{V}$ , it provides the best performance in the PC application.

In CM6802B/BH,  $f_{RTCT}=2 \times f_{pwm}=4 \times f_{pfc}$   $f_{RTCT}=200\text{Khz}$ ,  $f_{pwm}=100\text{Khz}$  and  $f_{pfc}=50\text{Khz}$  when  $V_{EAO}=0\text{V}$ , it provides the best performance in the PC application.

The oscillator frequency,  $f_{RTCT}$  is the similar formula in CM6800:

$$f_{RTCT} = \frac{1}{t_{RAMP} + t_{DEADTIME}}$$

The dead time of the oscillator is derived from the following equation:

$$t_{RAMP} = C_T \times R_T \times \ln \frac{V_{REF} - 1.25}{V_{REF} - 3.75}$$

at  $V_{REF} = 7.5\text{V}$ :

$$t_{RAMP} = C_T \times R_T \times 0.51$$

The dead time of the oscillator may be determined using:

$$t_{DEADTIME} = \frac{2.5\text{V}}{4.216\text{mA}} \times C_T = 593 \times C_T$$

The dead time is so small ( $t_{RAMP} \gg t_{DEADTIME}$ ) that the operating frequency can typically be approximately by:

$$f_{RTCT} = \frac{1}{t_{RAMP}}$$

$C_T$  should be greater than 470pF.

Let us use 1000PF Solving for  $R_T$  yields 7.75K. Selecting standard components values,  $C_T = 1000\text{pF}$ , and  $R_T = 7.75\text{k}\Omega$

The dead time of the oscillator determined two things:

- 1.) PFC minimum off time which is the dead time
- 2.) PWM skipping reference duty cycle: when the PWM duty cycle is less than the dead time, the next cycle will be skipped and it reduces no load consumption in some applications.

## PWM Section

### Pulse Width Modulator

The PWM section of the CM6802A/B/AH/BH is straightforward, but there are several points which should be noted. Foremost among these is its inherent synchronization to the PFC section of the device, from which it also derives its basic timing. The PWM is capable of current-mode or voltage-mode operation.

In current-mode applications, the PWM ramp (RAMP2) is usually derived directly from a current sensing resistor or current transformer in the primary of the output stage, and is thereby representative of the current flowing in the converter's output stage.  $DCI_{LIMIT}$ , which provides cycle-by-cycle current limiting, is typically connected to RAMP2 in such applications. For voltage-mode, operation or certain specialized applications, RAMP2 can be connected to a separate RC timing network to generate a voltage ramp against which  $V_{DC}$  will be compared. Under these conditions, the use of voltage feed-forward from the PFC buss can assist in line regulation accuracy and response. As in current mode operation, the DC  $I_{LIMIT}$  input is used for output stage over-current protection.

No voltage error amplifier is included in the PWM stage of the CM6802A/B/AH/BH, as this function is generally performed on the output side of the PWM's isolation boundary. To facilitate the design of opto-coupler feedback circuitry, an offset has been built into the PWM's RAMP2 input which allows  $V_{DC}$  to command a zero percent duty cycle for input voltages below around 1.8V.

### PWM Current Limit (DCILIMIT)

The DC  $I_{LIMIT}$  pin is a direct input to the cycle-by-cycle current limiter for the PWM section. Should the input voltage at this pin ever exceed 1V, the output flip-flop is reset by the clock pulse at the start of the next PWM power cycle. Beside, the cycle-by-cycle current, when the DC  $I_{LIMIT}$  triggered the cycle-by-cycle current. It will limit PWM duty cycle mode. Therefore, the power dissipation will be reduced during the dead short condition.

When DCILIMIT pin is connected with RAMP2 pin, the CM6802A/B/AH/BH's PWM section becomes a current mode PWM controller. Sometimes, network between DCILIMIT and RAMP2 is a resistor divider so the DCILIMIT's 1V threshold can be amplified to 1.5V or higher for easy layout purpose.

### PWM Brown Out (380V-OK Comparator)

The 380V-OK comparator monitors the DC output of the PFC and inhibits the PWM if this voltage on  $V_{FB}$  is less than its nominal 2.36V. Once this voltage reaches 2.36V, which corresponds to the PFC output capacitor being charged to its rated boost voltage, the soft-start begins. It is a hysteresis comparator and its lower threshold is 1.35V.

## PWM Control (RAMP2)

When the PWM section is used in current mode, RAMP2 is generally used as the sampling point for a voltage representing the current on the primary of the PWM's output transformer, derived either by a current sensing resistor or a current transformer. In voltage mode, it is the input for a ramp voltage generated by a second set of timing components ( $R_{RAMP2}$ ,  $C_{RAMP2}$ ), that will have a minimum value of zero volts and should have a peak value of approximately 5V. In voltage mode operation, feed-forward from the PFC output buss is an excellent way to derive the timing ramp for the PWM stage.

## Soft Start (SS)

Start-up of the PWM is controlled by the selection of the external capacitor at SS. A current source of  $10\mu A$  supplies the charging current for the capacitor, and start-up of the PWM begins at  $SS \sim 1.4V$ . Start-up delay can be programmed by the following equation:

$$C_{SS} = t_{DELAY} \times \frac{10\mu A}{1.8V}$$

where  $C_{SS}$  is the required soft start capacitance, and the  $t_{DEALY}$  is the desired start-up delay.

It is important that the time constant of the PWM soft-start allow the PFC time to generate sufficient output power for the PWM section. The PWM start-up delay should be at least 5ms.

Solving for the minimum value of  $C_{SS}$ :

$$C_{SS} = 5ms \times \frac{10\mu A}{1.8V} \approx 27nF$$

Caution should be exercised when using this minimum soft start capacitance value because premature charging of the SS capacitor and activation of the PWM section can result if  $V_{FB}$  is in the hysteresis band of the 380V-OK comparator at start-up. The magnitude of  $V_{FB}$  at start-up is related both to line voltage and nominal PFC output voltage. Typically, a  $0.05\mu F$  soft start capacitor will allow time for  $V_{FB}$  and PFC out to reach their nominal values prior to activation of the PWM section at line voltages between 90Vrms and 265Vrms.

## Generating $V_{CC}$

After turning on CM6802A/B/AH/BH at 13V, the operating voltage can vary from 10V to 17.9V. That's the two ways to generate  $V_{CC}$ . One way is to use auxiliary power supply around 15V, and the other way is to use bootstrap winding to self-bias CM6802A/B/AH/BH system. The bootstrap winding can be either taped from PFC boost choke or from the transformer of the DC to DC stage. The ratio of winding transformer for the bootstrap should be set between 18V and 15V.

A filter network is recommended between  $V_{CC}$  (pin 13) and bootstrap winding. The resistor of the filter can be set as following.

$$R_{FILTER} \times I_{VCC} \sim 2V, I_{VCC} = I_{OP} + (Q_{PFCFET} + Q_{PWMFET}) \times f_{sw}$$
$$I_{OP} = 3mA \text{ (typ.)}$$

If anything goes wrong, and  $V_{CC}$  goes beyond 19.4V, the PFC gate (pin 12) drive goes low and the PWM gate drive (pin 11) remains function. The resistor's value must be chosen to meet the operating current requirement of the CM6802A/B/AH/BH itself (5mA, max.) plus the current required by the two gate driver outputs.

### EXAMPLE:

With a wanting voltage called,  $V_{BIAS}$ , of 18V, a  $V_{CC}$  of 15V and the CM6802A/B/AH/BH driving a total gate charge of 90nC at 100kHz (e.g. 1 IRF840 MOSFET and 2 IRF820 MOSFET), the gate driver current required is:

$$I_{GATEDRIVE} = 100kHz \times 90nC = 9mA$$

$$R_{BIAS} = \frac{V_{BIAS} - V_{CC}}{I_{CC} + I_G}$$
$$R_{BIAS} = \frac{18V - 15V}{5mA + 9mA}$$

Choose  $R_{BIAS} = 214\Omega$

The CM6802A/B/AH/BH should be locally bypassed with a  $1.0\mu F$  ceramic capacitor. In most applications, an electrolytic capacitor of between  $47\mu F$  and  $220\mu F$  is also required across the part, both for filtering and as part of the start-up bootstrap circuitry.

## Leading/Trailing Modulation

Conventional Pulse Width Modulation (PWM) techniques employ trailing edge modulation in which the switch will turn on right after the trailing edge of the system clock. The error amplifier output is then compared with the modulating ramp up. The effective duty cycle of the trailing edge modulation is determined during the ON time of the switch. Figure 4 shows a typical trailing edge control scheme.

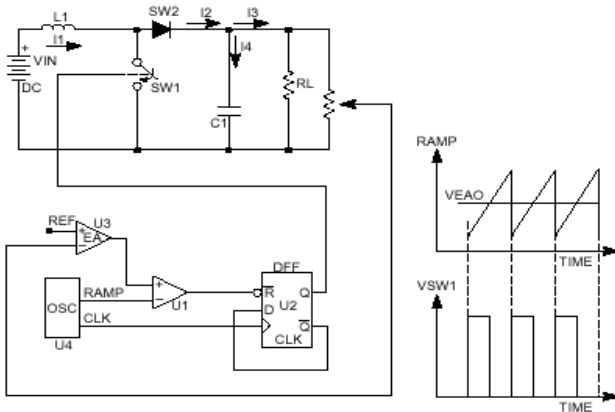

Figure 4. Typical Trailing Edge Control Scheme

In case of leading edge modulation, the switch is turned OFF right at the leading edge of the system clock. When the modulating ramp reaches the level of the error amplifier output voltage, the switch will be turned ON. The effective duty-cycle of the leading edge modulation is determined during OFF time of the switch.

Figure 5 shows a leading edge control scheme. One of the advantages of this control technique is that it required only one system clock. Switch 1 (SW1) turns off and switch 2 (SW2) turns on at the same instant to minimize the momentary “no-load” period, thus lowering ripple voltage generated by the switching action. With such synchronized switching, the ripple voltage of the first stage is reduced. Calculation and evaluation have shown that the 120Hz component of the PFC’s output ripple voltage can be reduced by as much as 30% using this method.

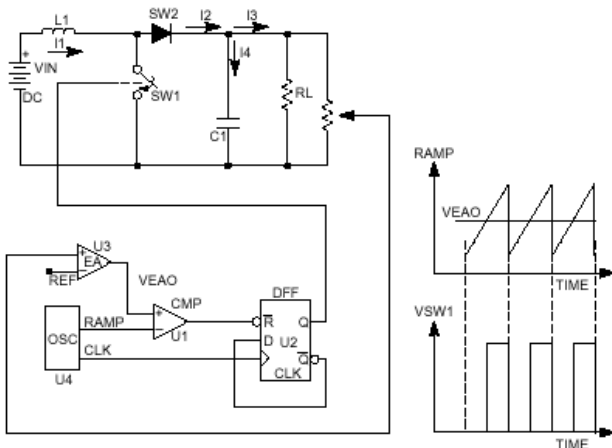
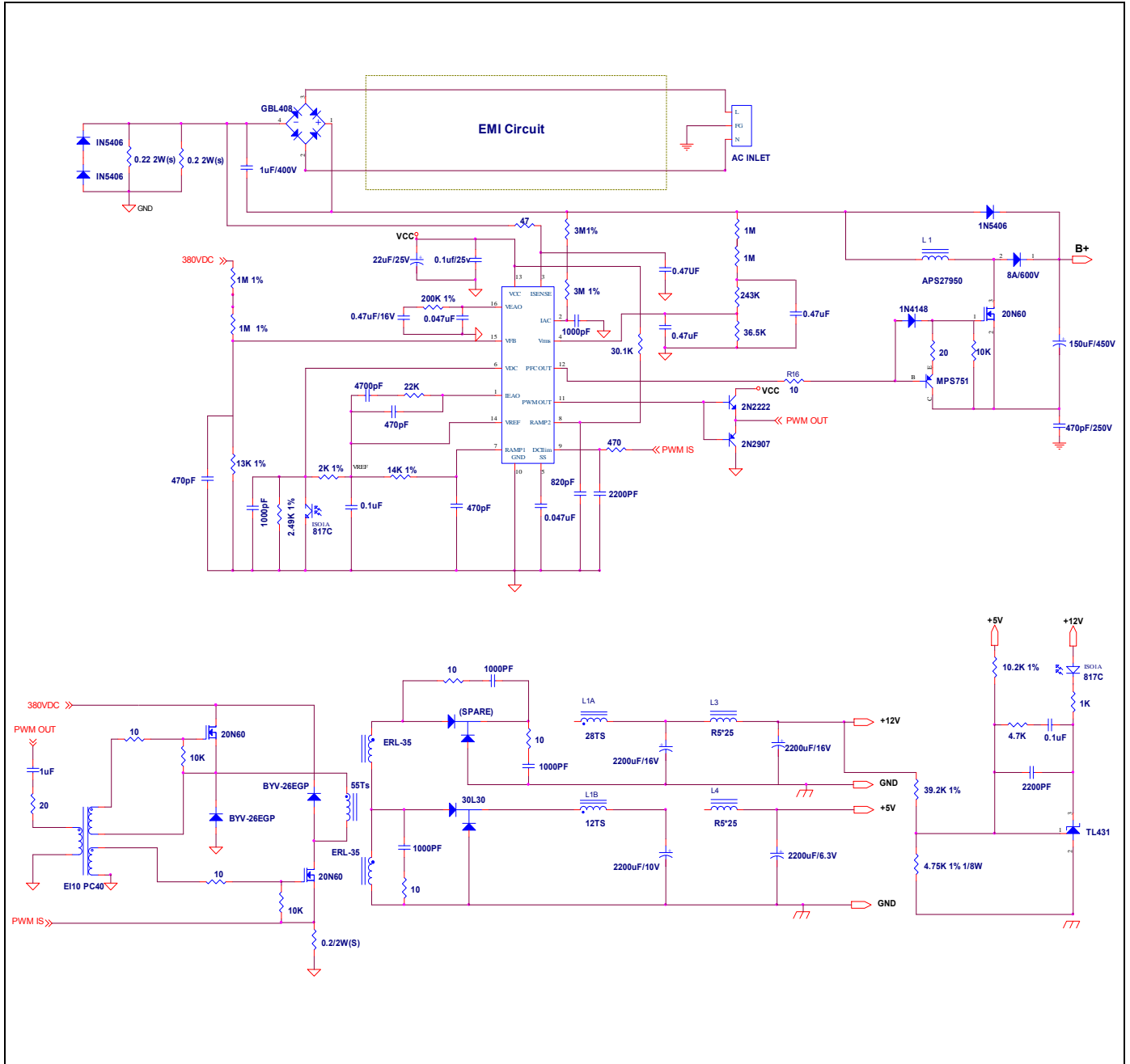

Figure 5. Typical Leading Edge Control Scheme

## CM6802A/B/AH/BH APPLICATION CIRCUIT (Voltage Mode)





## PACKAGE DIMENSION

### 16-PIN SOP (S16)

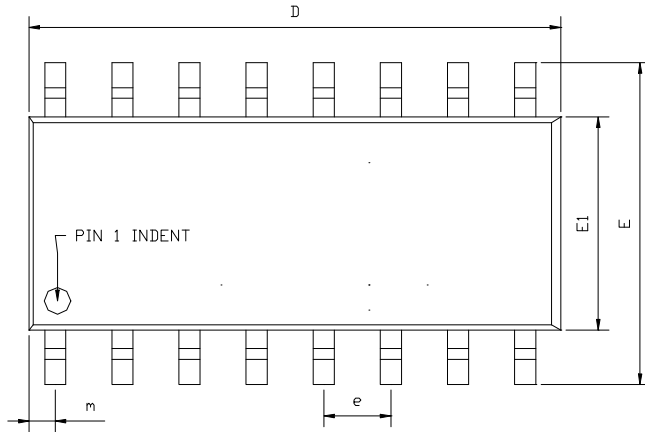

SYMBOLS	DIMENSIONS IN MILLIMETERS			DIMENSIONS IN INCHS		
	MIN	NOM	MAX	MIN	NOM	MAX
A1	0.05	---	0.15	0.002	---	0.006
A2	1.40	---	1.55	0.055	---	0.061
b	0.30	---	0.51	0.012	---	0.020
C	0.15	---	0.26	0.006	---	0.010
D	9.80	---	10.06	0.386	---	0.396
E	5.79	---	6.20	0.228	---	0.244
E1	3.76	---	4.01	0.148	---	0.158
e	---	1.27	---	---	0.050	---
L	0.38	---	0.69	0.015	---	0.035
m	0.43	---	0.69	0.017	---	0.027
θ	0°	---	8°	0°	---	8°

EXPOSED PAD DIMENSION : (mm)  
PAD SIZE: X=2.3 ; Y=2.8

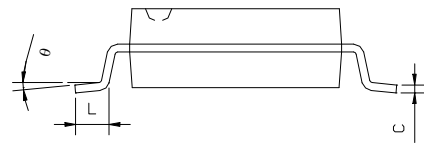
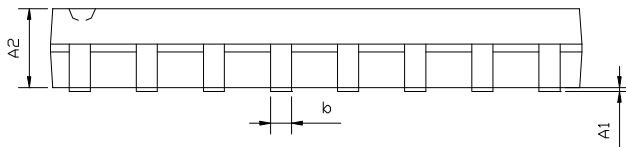

### 16-PIN PDIP (P16)

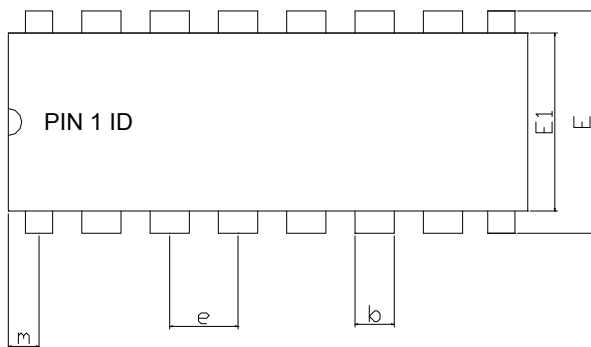

SYMBOLS	DIMENSIONS IN MILLIMETERS			DIMENSIONS IN INCHS		
	MIN	NOM	MAX	MIN	NOM	MAX
A	---	---	4.32	---	---	0.170
A1	0.38	---	---	0.015	---	---
b	1.40	---	1.65	0.055	---	0.065
b1	0.40	---	0.56	0.016	---	0.022
C	0.20	---	0.31	0.008	---	0.012
D	18.79	---	19.31	0.740	---	0.760
E	7.49	---	8.26	0.295	---	0.325
E1	6.09	---	6.61	0.240	---	0.260
e	---	2.54	---	---	0.100	---
L	3.18	---	---	0.125	---	---
m	0.50	---	---	0.02	---	---
θ	0°	---	15°	0°	---	15°

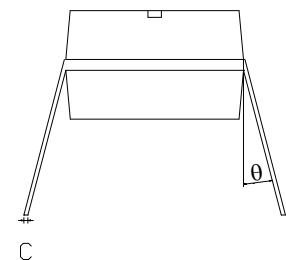
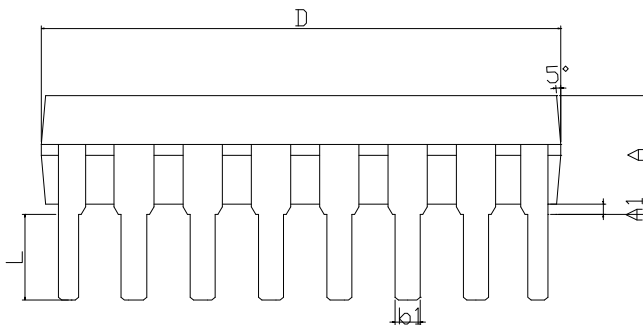



## CM6802A/B/AH/BH (Dynamic Soft PFC/Green PWM)

<http://www.championmicro.com.tw>

EPA/80++ ZVS-Like PFC/PWM COMBO CONTROLLER

Design for High Efficient Power Supply at both Full Load and Light Load

---

### IMPORTANT NOTICE

Champion Microelectronic Corporation (CMC) reserves the right to make changes to its products or to discontinue any integrated circuit product or service without notice, and advises its customers to obtain the latest version of relevant information to verify, before placing orders, that the information being relied on is current.

A few applications using integrated circuit products may involve potential risks of death, personal injury, or severe property or environmental damage. CMC integrated circuit products are not designed, intended, authorized, or warranted to be suitable for use in life-support applications, devices or systems or other critical applications. Use of CMC products in such applications is understood to be fully at the risk of the customer. In order to minimize risks associated with the customer's applications, the customer should provide adequate design and operating safeguards.

#### HsinChu Headquarter

5F, No. 11, Park Avenue II,  
Science-Based Industrial Park,  
HsinChu City, Taiwan

TEL: +886-3-567 9979  
FAX: +886-3-567 9909  
<http://www.champion-micro.com>

#### Sales & Marketing

21F., No. 96, Sec. 1, Sintai 5th Rd., Sijhih City,  
Taipei County 22102,  
Taiwan, R.O.C.

TEL: +886-2-2696 3558  
FAX: +886-2-2696 3559

[www.s-manuals.com](http://www.s-manuals.com)