



FOR SALES AND SERVICE PLEASE CALL:

PTB SALES T :: 866.332.0500
F :: 626.334.2151
www.ptbsales.com

DATE SERVICED: _____

263-13228I

[View our inventory](#)

Power Supply Unit
For Turbo Molecular Pump
Model: EI-D1003M,-D1103M
Model: EI-D1303M,-D2003M
Model: EI-D2203M,-D2303M
Model: EI-D3203M,-D3403M
Model: EI-D4203M
INSTRUCTION MANUAL

 SHIMADZU

Power Supply Unit for Turbo Molecular Pump

Model:EI-D1003M

Model:EI-D1103M

Model:EI-D1303M

Model:EI-D2003M

Model:EI-D2203M

Model:EI-D2303M

Model:EI-D3203M

Model:EI-D3403M

Model:EI-D4203M

INSTRUCTION MANUAL

**Read the instruction manual thoroughly before you use the product.
Keep this instruction manual for future reference.**

SHIMADZU CORPORATION
Semiconductor Equipment Division

Introduction

Thank you for choosing the EI-Dxx03M Power Supply Unit for Turbo Molecular Pump (hereafter referred to as "power supply unit" or "EI-Dxx03M"). Please read the instruction manual carefully before using the power supply unit, and save the instruction manual for future reference.

This instruction manual explains detailed operations of the power supply unit and cables. For instructions regarding the pump unit, please refer to the instruction manual for the pump unit to be used.

Standard type is explained in this manual. For special order type, please refer to the outlines and constructions of each specification.

Copyrights and Disclaimers

This document is copyrighted by Shimadzu Corporation. Please refrain from reproducing or copying part or all of this document without permission from Shimadzu.

In an effort to improve the product, this document may be revised in the future without notice.

Every effort has been made to prepare an accurate and complete manual, but if an error or omission should be discovered, revisions might not be possible immediately.

Shimadzu does not take responsibility for any effects that may result from the use of this manual.

Copyright © 2003-2006 Shimadzu Corporation. All rights reserved.

Precautions for Safe Operation

The instruction manual's nomenclature for warnings and precautions complies with the following safety warning symbols.

WARNING

Indicates a potentially hazardous situation which, if not avoided, could result in serious injury or possibly death.

CAUTION

Indicates a potentially hazardous situation which, if not avoided, may result in minor to moderate injury or equipment damage.

NOTICE

Emphasizes additional information that is provided to ensure the proper use of this product.

WARNING

Turbo molecular pump repair and/or power supply repair can be very hazardous. Only trained technicians who are authorized by Shimadzu may do service of products.



WARNING

Neither overhaul nor modify the pump proper and power supply unit without admission. Doing so would impair safety of the pump proper.



WARNING

Decisions on system compatibility should be made by the system designer or the person deciding the specifications after conducting tests as necessary. The responsibility for guaranteeing the expected performance and safety of the system lies with the person who decides system compatibility.

CAUTION

The standard power input voltage of the power supply unit EI-Dxx03M (the "xx" number indicates the model of the corresponding pump) is AC 200 - 240 V \pm 10%. Connect the power supply unit to the voltage indicated on the rear panel label only. Connection of the power supply unit to the incorrect input voltage can cause damage to the equipment. Supply the power via a breaker (rating 15A). Please provide PE(Protective Earth) connection to the terminal of a "PE" marked wire in final application.

CAUTION

If an EI-Dxx03M power supply unit is used in combination with an existing pump that was operated in combination with a power supply unit not having the variable speed function (EI-xx03MD), the variable speed function cannot be used. (the "xx" number indicates the model of the corresponding pump.)

If the power supply unit is to be combined with an existing pump, modification and operational inspections are necessary. Please contact Shimadzu for detailed information.

CAUTION

The following "CAUTIONS" are to prevent operation anomalies.

1. Do not interrupt the electrical power operating the turbo molecular pump while the turbo molecular pump is in operation.
2. Do not connect or disconnect the turbo molecular pump control cable during the time the power supply is "ON".
3. Do not operate any equipment (i.e. drill motor, welding machine, etc.) that produces electromagnetic pollution, noise, etc., in the immediate proximity of an operating turbo molecular pumping system (pump, power supply, cables, etc).
4. When using the variable speed function to change the pump rotation rate, use a rotation rate that does not cause resonance with other devices installed at the site.

○ Explanation of label



(1) **HOT SURFACE** : Risk of burn. (Notes 1)

- Keep off from touching surface of the pump as it is heated.

- Keep off from touching upper side surface of the power supply while the pump is in deceleration as it is heated.



(2) Do not remove cover, or else it may cause some changes inside and it is failed.



(3) Do not shut off ventilation, or else the inside of power supply get heated and it is failed.



(4) Be sure to use specified cable for this power supply. If not, it may cause connector be broken and power supply itself failed.



(5) **SECURITY seal**

This label certifies that the product was made or maintained by Shimadzu or by Shimadzu authorized facility.

In case "this label is removed" or "there is a mark showing once this label has been removed", Shimadzu warranty shall not be applied to the product.

(Notes 1) The power supply units for some production lots come with a single nameplate, on which the name is indicated in both English and Japanese, whereas the power supply units for other production lots come with two nameplates, one in English and one in Japanese.

○ Location of label

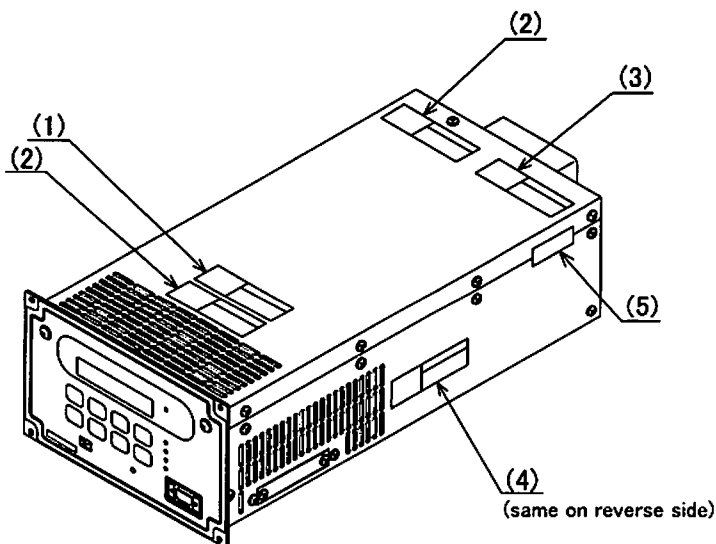

○ Installation Precautions

Do not apply abnormal loads to the turbo molecular pump control cable plug and/or connector. Abnormal loads may cause cable disconnection.

- (1) Do not pull the turbo molecular pump control cable by the connector or plug.



- (2) When installing the power supply unit into equipment, do not allow any electrical cables to be in tension or to have very tight bending radii.

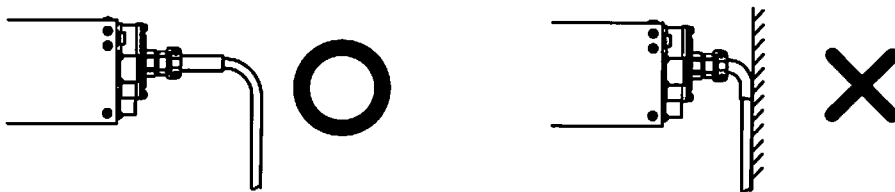

- (3) Do not bundle the turbo molecular pump control cable with any cables.

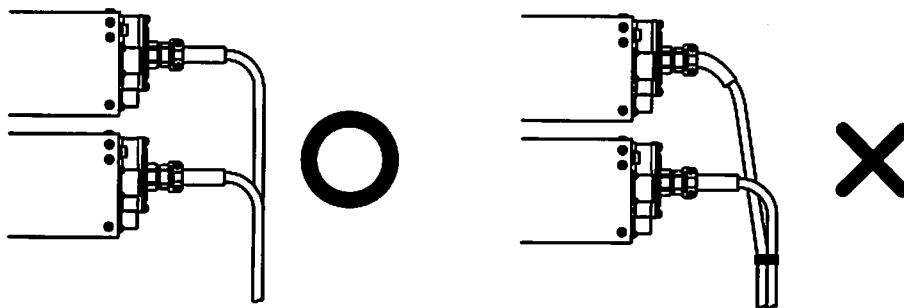

- (4) Do not twist the turbo molecular pump control cable during connection.



○ Part Replacement

The lifetime of parts are specified as below.

The request for changing parts exceeding the estimated lifetime should be made to Shimadzu or an approved service company in order for safety and adequate performance of the pump and power supply unit.

Table 1 Estimated Part Life.

| Parts List | Estimated Part Life |
|------------------------|---------------------|
| Transformer | 10 years |
| Electrolytic condenser | 5 years |
| Cooling fan | 5 years |
| Button-type battery | 10 years |

○ Warranty period

12 months on new TMP's from the date of shipment from Shimadzu, or from any of its worldwide sales offices.

○ Conditional warranty

During the warranty period and under normal operation, if the TMP fails to meet its product specification due to defects in material and/or workmanship, Shimadzu will, at its discretion, either repair it or exchange it with a new one for free.

○ Scope of the warranty

The warranty covers only TMPs, controllers and accessories sold by Shimadzu.

○ Warranty of repaired or replacement parts

In-warranty repaired or replacement parts are warranted only for the remaining unexpired portion of the original warranty period applicable to the parts that have been repaired or replaced.

○ Exemption from the warranty

During the warranty period, Shimadzu will charge for repair or exchange in the following cases:

- 1) Failure caused by natural disasters or fire.
- 2) Failure or functional deterioration due to the following:
 - a) Pumping of special gases and materials
 - b) Ingestion of foreign objects through the TMP's protective net
 - c) TMP is operated differently than what is prescribed in the instruction manual
 - d) When Shimadzu determines through failure analysis that the cause of failure was due to abnormal operation or external circumstances. our engineers judge that the cause of the trouble is an irregular operation
- 3) Warranty is voided if the "Security Seal" on the product has been removed, hampered with, or altered.

○ Disposal of Products and Parts

Please contact Shimadzu for proper disposal of its products or parts. There is a possibility to pollute the environment with the material of the parts, when you dispose this product in an inappropriate way.

○ LIMITATION OF LIABILITY

EXCEPT AS STATED HEREIN, SHIMADZU MAKES NO WARRANTY, EXPRESSED OR IMPLIED (EITHER IN FACT OR BY OPERATION OF LAW), STATUTORY OR OTHERWISE: AND, EXCEPT AS STATED HEREIN, SHIMADZU SHALL HAVE NO LIABILITY FOR SPECIAL OR CONSEQUENTIAL DAMAGES OF ANY KIND OR FROM ANY CAUSE ARISING OUT OF THE SALE, INSTALLATION, OR USE OF ANY OF ITS PRODUCTS.

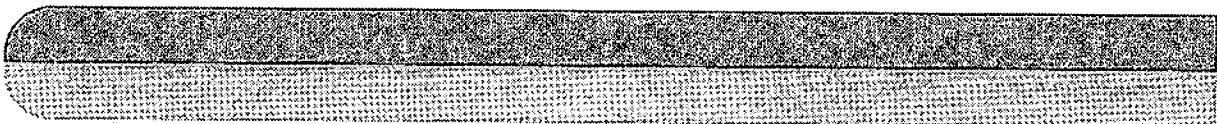

This page is intentionally left blank.

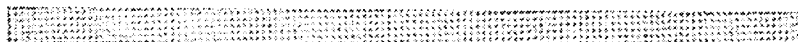
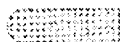

Table of contents

Introduction

| | |
|---|-----|
| Copyrights and Disclaimers | i |
| Precautions for Safe Operation | ii |
| ○ Explanation of label | iv |
| ○ Location of label. | iv |
| ○ Installation Precautions | v |
| ○ Part Replacement | vi |
| ○ Warranty period | vi |
| ○ Conditional warranty | vi |
| ○ Scope of the warranty | vi |
| ○ Warranty of repaired or replacement parts | vi |
| ○ Exemption from the warranty. | vi |
| ○ Disposal of Products and Parts | vii |
| ○ LIMITATION OF LIABILITY | vii |
| Table of contents | ix |

Section 1 OUTLINE AND DESCRIPTIONS

| | |
|--------------------------------------|---|
| 1.1 Outline | 2 |
| 1.2 Descriptions | 3 |
| 1.2.1 Power Supply Unit | 3 |
| 1.2.2 Control Cable | 4 |
| 1.2.3 Motor Cable | 4 |
| 1.2.4 Standard Accessories | 5 |

Section 2 IDENTIFICATION AND FUNCTION

| | |
|---------------------------------|---|
| 2.1 Power Supply Unit | 8 |
|---------------------------------|---|

Section 3 CONSTRUCTION AND PRINCIPLE

3.1 Power Supply Unit 12

Section 4 SPECIFICATIONS

4.1 Power Supply Unit 14
4.2 Standards Fulfilled 16

Section 5 INSTALLATION

5.1 Installation of the Power Supply Unit 18
5.1.1 Location of the Power Supply Unit 18
5.1.2 Installation of the Power Supply Unit 18
5.1.3 Compatibility with Previous Models 21
5.2 Connection of Power Cable 23
5.3 Connection of the Pump to the Power Supply Unit 24

Section 6 OPERATION

6.1 Outline 28
6.1.1 Introduction 28
6.1.2 Operation Flowchart 29
6.2 Start-up Preparation 35
6.2.1 Start-up Preparation Sequence in LOCAL Mode 35
6.2.2 Start-up Preparation Sequence in REMOTE Mode 35
6.3 Start-up 36
6.3.1 Start-up Sequence in LOCAL Mode 36
6.3.2 Start-up Sequence in REMOTE Mode 36
6.4 Shutting Down 37
6.4.1 Preparations Prior to Shutting Down Operation 37
6.4.2 Shutting Down Sequence in LOCAL Mode 37
6.4.3 Shutting Down Sequence in REMOTE Mode 38
6.5 Variable Speed Operation 39
6.5.1 Outline 39
6.5.2 Operation from Start-up to Low Speed Rotation 40

- 6.5.3 Operation from Rated Speed Rotation to Low Speed Rotation . . . 41
- 6.5.4 Operation from Low Speed Rotation to Rated Speed Rotation . . . 41
- 6.6 Software Operation 43
- 6.7 Remote-Control Connector 58
 - 6.7.1 Specifications 58
 - 6.7.2 Compatibility with Previous Models 60
 - 6.7.2.1 Replacing the EI-xx03M/MD Power Supply Unit 60
 - 6.7.2.2 Replacing EI-xx03MZ Power Supply Units 62

Section 7 TROUBLESHOOTING

- 7.1 Nothing Happens After an Operation is Made 66
- 7.2 Power Failures 67
 - 7.2.1 Power Failure Counter-Operation 68
- 7.3 Vacuum Pressure Rise 69
- 7.4 Abnormal Noise and/or Vibration 69
- 7.5 Alarm Detection Capabilities 69
 - 7.5.1 Movement in Alarm Detection Capabilities (ALARM) 69
 - 7.5.2 Movement in Alarm Detection Capabilities (WARNING) 70
 - 7.5.3 Reset Procedure 70

Appendix A COMMUNICATIONS

- A.1 GENERAL SPECIFICATION A-2
- A.2 INTERFACE SPECIFICATION A-3
 - A.2.1 RS-232C A-3
 - A.2.1.1 Transmission Specification A-3
 - A.2.1.2 Communications Connector A-3
 - A.2.1.3 CABLE A-3
 - A.2.2 RS-485 A-5
 - A.2.2.1 Transmission Specification A-5
 - A.2.2.2 Communications Connector A-5
 - A.2.2.3 CABLE A-5
- A.3 POWER SUPPLY TO COMPUTER CONNECTION A-7
 - A.3.1 Communication Cable Connection A-7
 - A.3.2 Serial Communications Baud Rate Configuration A-7
 - A.3.3 RS-485 Multi-drop Settings A-7
- A.4 SERIAL COMMUNICATIONS PROTOCOL A-8
 - A.4.1 Basic Message Structure A-8

Table of contents

| | | |
|-------|---|------|
| A.4.2 | Character to Character Time-out: 0.1 sec. | A-8 |
| A.4.3 | Command to Answer Time-out: 1 sec. | A-9 |
| A.4.4 | Power Supply Command Send Retry Cycles: 5 | A-9 |
| A.4.5 | Command Transmission Specification. | A-9 |
| A.4.6 | Receiving Sequence | A-9 |
| A.4.7 | Using the Checksum Byte | A-9 |
| A.4.8 | Outline of Multi-drop Communications. | A-10 |
| A.5 | TABLE OF COMMANDS | A-11 |
| A.6 | COMMAND DESCRIPTION. | A-17 |
| A.6.1 | Operation Mode | A-17 |
| A.6.2 | Operation | A-18 |
| A.6.3 | Run Status | A-19 |
| A.6.4 | Parameters | A-20 |
| A.6.5 | Events | A-20 |
| A.6.6 | Timer | A-21 |
| A.6.7 | History | A-21 |
| A.6.8 | Settings | A-22 |
| A.6.9 | Shared Answer | A-22 |
| A.7 | RS-232C COMMANDS / ANSWERS | A-23 |
| A.8 | RELATION OF LOCAL MODE TO REMOTE MODE OPERATIONS | A-26 |
| A.9 | TROUBLESHOOTING | A-27 |
| A.9.1 | No Message can Transmit and Receive | A-27 |
| A.9.2 | Sending and Receiving are Done, But Receivable Messages are Invalid | A-27 |
| A.9.3 | Characters Get Disordered from Time to Time, Then Resulting in CHECKSUM Error. | A-27 |

OUTLINE AND DESCRIPTIONS

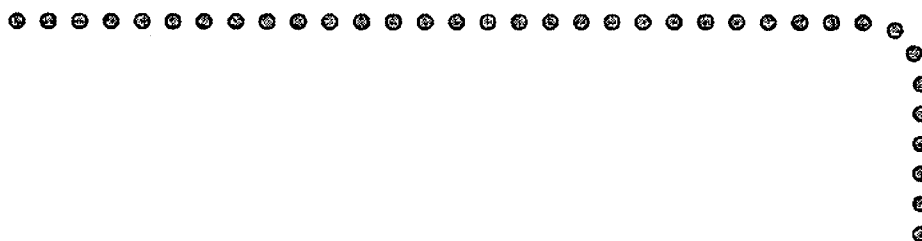

- 1.1 Outline
- 1.2 Descriptions
 - 1.2.1 Power Supply Unit
 - 1.2.2 Control Cable
 - 1.2.3 Motor Cable
 - 1.2.4 Standard Accessories

1 1.1 Outline

The turbo molecular pump is a vacuum pump. The turbo molecular pump is used with a backing vacuum pump to create a high vacuum in a vacuum chamber.

Typical Applications ; Semiconductor equipments,
 Industrial equipments,
 R&D applications,
 The other ultra high vacuum applications.

The turbo molecular pump (one standard set) consists of the following items.

- Pump 1
- Power Supply Unit 1
- Control Cable 1
- Motor Cable 1
- Standard Accessories 1 Set

The cable length must be specified for the magnetic bearing cable and motor cable. (Refer to Sections 1.2.2 and 1.2.3.)

1.2 Descriptions

1.2.1 Power Supply Unit

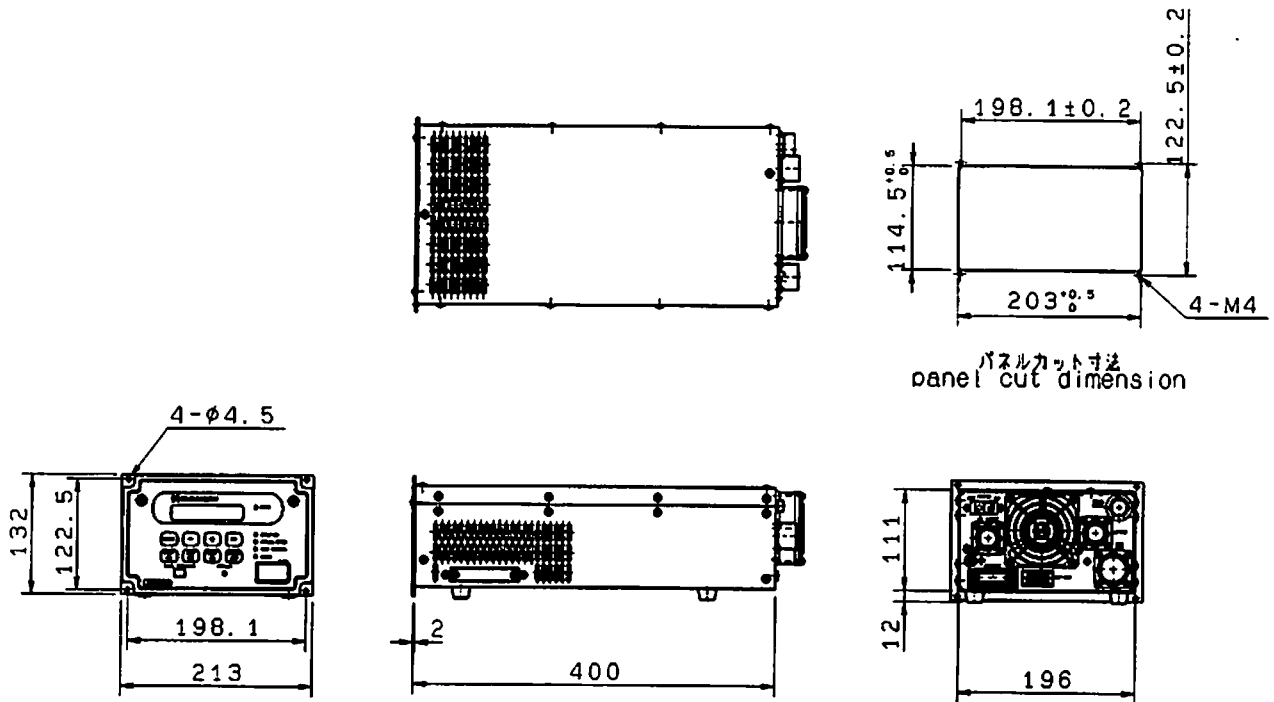

| Description | Parts number |
|-------------|--------------|
| EI-D1003M | 262-78689-02 |
| EI-D1103M | 262-78690-02 |
| EI-D1303M | 262-78688-02 |
| EI-D2003M | 262-78691-02 |
| EI-D2203M | 262-78692-02 |
| EI-D2303M | 262-78693-02 |
| EI-D3203M | 262-78685-02 |
| EI-D3403M | 262-78694-02 |
| EI-D4203M | 262-78696-02 |

Fig.1-1 Outside Dimensions of Power Supply Unit

SECTION 1 OUTLINE AND DESCRIPTIONS

1.2.2 Control Cable

The cable can be selected from the following.

| Description | Note | Parts number |
|---------------|--|--------------|
| Control Cable | 3 meters length, straight plugs for both sides. | 262-78187-03 |
| | 5 meters length, straight plugs for both sides. | 262-78187-05 |
| | 7 meters length, straight plugs for both sides. | 262-78187-07 |
| | 10 meters length, straight plugs for both sides. | 262-78187-10 |
| | 15 meters length, straight plugs for both sides. | 262-78187-15 |
| | 20 meters length, straight plugs for both sides. | 262-78187-20 |
| | 30 meters length, straight plugs for both sides. | 262-78187-30 |

1.2.3 Motor Cable

The cable can be selected from the following

| Description | Note | Parts number |
|-------------|--|--------------|
| Motor Cable | (for Air cooled type and Air cooled chemical type) | |
| | 3 meters length, straight plugs for both sides. | 262-76410-03 |
| | 5 meters length, straight plugs for both sides. | 262-76410-05 |
| | 7 meters length, straight plugs for both sides. | 262-76410-07 |
| | 10 meters length, straight plugs for both sides. | 262-76410-10 |
| | 15 meters length, straight plugs for both sides. | 262-76410-15 |
| | 20 meters length, straight plugs for both sides. | 262-76410-20 |
| | 30 meters length, straight plugs for both sides. | 262-76410-30 |
| | (for Wide range type and Wide range chemical type) | |
| | 3 meters length, straight plugs for both sides. | 262-76409-03 |
| | 5 meters length, straight plugs for both sides. | 262-76409-05 |
| | 7 meters length, straight plugs for both sides. | 262-76409-07 |
| | 10 meters length, straight plugs for both sides. | 262-76409-10 |
| | 15 meters length, straight plugs for both sides. | 262-76409-15 |
| | 20 meters length, straight plugs for both sides. | 262-76409-20 |
| | 30 meters length, straight plugs for both sides. | 262-76409-30 |

1.2.4 Standard Accessories

| | Description | Q'ty | Notes | Parts Number |
|---|--------------------------|------|--|------------------------------|
| 1 | Power cable | 1 | 5meters length | 262-76773-05 |
| 2 | Remote Control Connector | 1 | MR-34MG (Pin type connector) MR-34L4 (Connector hood) | 070-50791-63 070-50792-75 |
| 3 | Instruction Manual | 1 | | 263-13228 |

SECTION 1 OUTLINE AND DESCRIPTIONS

This page is intentionally left blank.

IDENTIFICATION AND FUNCTION

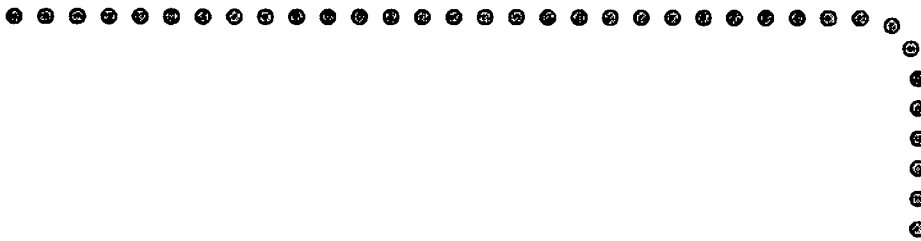

2.1 Power Supply Unit

2.1 Power Supply Unit

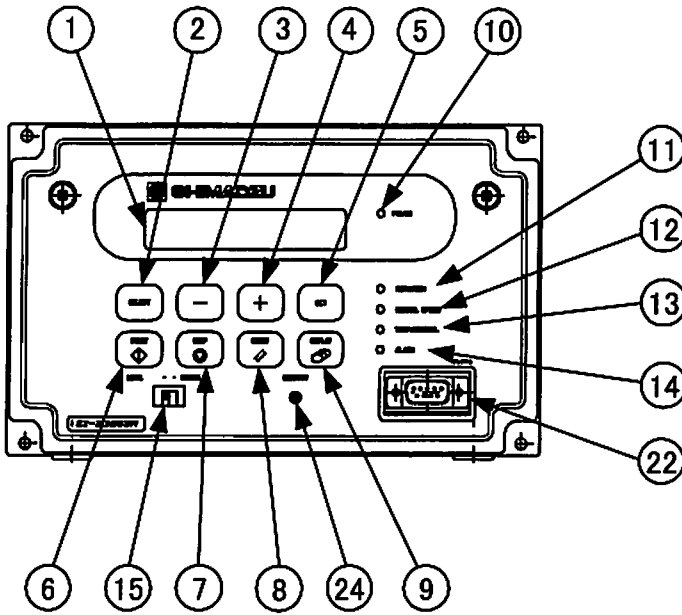

Fig.2-1 Front Control Panel

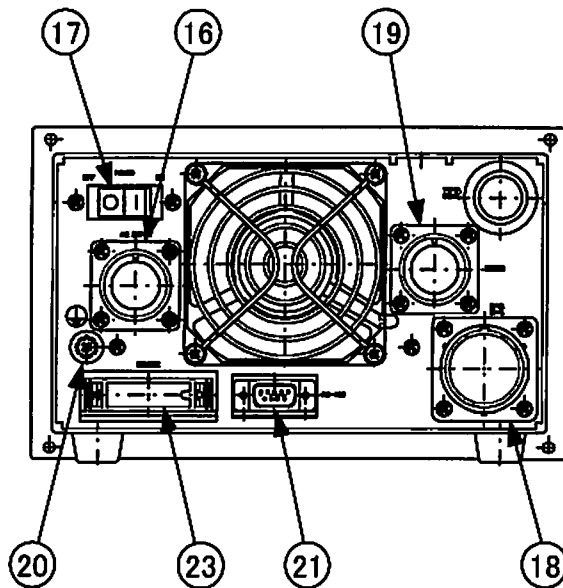

Fig.2-2 Rear Panel

- (1) LCD----- Display operation monitor, alarm contents, settings (see Section 6.6 "Software Operation")
 - (2) SELECT KEY ----- LCD display operation key, select menu
 - (3) + KEY ----- LCD display operation key, previous menu or addition
 - (4) - KEY----- LCD display operation key, next menu or subtraction
 - (5) SET KEY ----- LCD display operation key, set menu
 - (6) START SWITCH----- Press to start rotation of the pump's rotor.
 - (7) STOP SWITCH----- Press to apply the brake to stop rotation of the pump's rotor.
 - (8) RESET SWITCH----- Press to stop the buzzer after an alarm or warning occurs. After remedying the cause of the alarm, press the RESET switch again to turn off the ALARM lamp. However, the buzzer sounds again if the RESET switch is pressed again before the cause of the alarm is remedied.
 - (9) DISPLAY SWITCH ----- LCD display operation key, change display mode.
 - (10) POWER LAMP ----- Power On indicator lamp (green)
 - (11) ROTATION LAMP----- Operation indicator lamp indicating that the pump's rotor is running (green)
 - (12) NORMAL SPEED LAMP ----- Operation indicator lamp indicating that the pump's rotor is rotating normally (green)
 - (13) TEMP. CONTROL LAMP----- Not used with EI-Dxx03M.
 - (14) ALARM LAMP----- Alarm/warning lamp (yellow). See 10.6 "Alarm Detection Capabilities." Lights when an alarm occurs or flashes to give a warning.
 - (15) REMOTE/LOCAL SELECTION SWITCH----- Remote/Local selection switch; The remote mode allows the turbo molecular pump to be controlled by employing the external control connector (24) or serial interface connector ((22), (23)), located on the rear panel of the power supply unit. The local mode allows controlling the turbo molecular pump from the front panel
 - (16) AC INPUT CONNECTOR----- Power cable receptacle
 - (17) POWER SWITCH ----- Power switch
 - (18) CONTROL CONNECTOR ----- Control cable receptacle
 - (19) MOTOR CONNECTOR ----- Motor cable receptacle
 - (20) EARTH GROUND ----- Electrical grounding terminal
 - (21) RS-485 CONNECTOR----- Serial interface connector (Note 1)
 - (22) RS-232C CONNECTOR ----- Serial interface connector (Note 1)
 - (23) REMOTE CONNECTOR ----- Remote-control connector
 - (24) CONTRAST ----- Adjusts the contrast of the LCD
- (Note 1) See APPENDIX-A "COMMUNICATIONS" for details.

SECTION 2 IDENTIFICATION AND FUNCTION

2

This page is intentionally left blank.

CONSTRUCTION AND PRINCIPLE

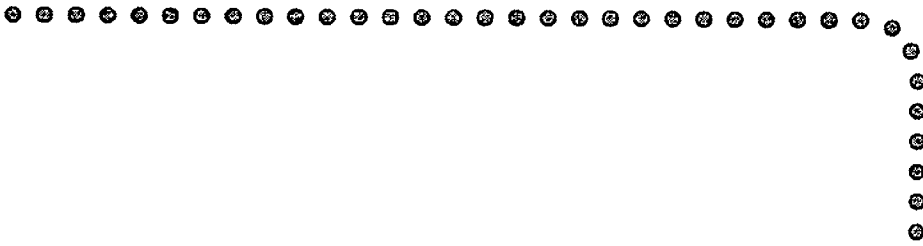

3.1 Power Supply Unit

3.1 Power Supply Unit

The power supply unit is composed of the magnetic bearing control system and the high frequency motor system and does not use back up batteries for electrical power failure.

The magnetic bearing control system controls the levitation of the rotor inside the turbo molecular pump. The system detects the rotor position by an electrical signal received from the gap sensors and maintains the levitation by regulating the current to the magnetic bearings.

The high frequency motor system rotates the rotor at a rated rotational speed. This frequency power system converts AC/single phase commercial power to controlled DC/three phase pulsed power. The DC/three phase pulsed power drives the DC motor that is an integral part of the rotor. If the electrical power is interrupted while the rotor is in a high-speed rotation, then the motor becomes a generator to power the magnetic bearing system during a power failure deceleration mode; therefore, the need for a battery backup system is eliminated.

The power supply unit is equipped with an RS-232C and an RS-485 serial interface and with Contact input/output to operate the turbo molecular pump from an external source. The operational status can be monitored and the history retrieved through the RS-232C and RS-485. See APPENDIX-A "COMMUNICATIONS" for instructions to remotely operate the turbo molecular pump using the RS-232C and RS-485 serial interface.

The turbo molecular pump, the power supply, the control cable, and the motor cable are respectively interchangeable among any products of the same model.

Fig.1-1 shows the external dimensions of the power supply unit.

The power supply unit, control cable, motor cable, and the pump unit are all mutually compatible. However, only pumps and power supply units with the same series number (the "xx" number) are compatible with each other.

SPECIFICATIONS

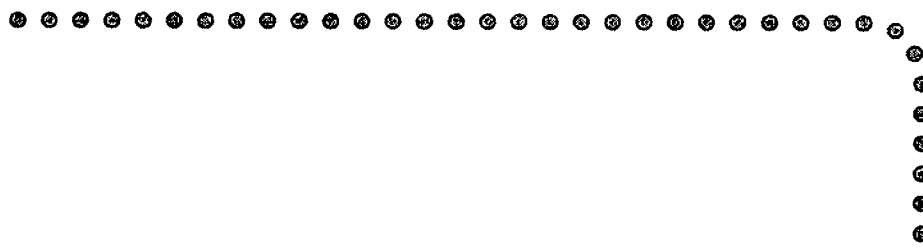

- 4.1 Power Supply Unit
- 4.2 Standards Fulfilled

SECTION 4 SPECIFICATIONS

4.1 Power Supply Unit

| Power supply unit model | | EI-D1003M | EI-D1103M | EI-D1303M | EI-D2003M | |
|----------------------------|------------------------------|--|--|--|--|--|
| Suitable pump | | TMP-803M TMP-803MC TMP-803LM TMP-803LMC | TMP-1003M TMP-1003MC TMP-1003LM TMP-1003LMC | TMP-1103MP TMP-1103MPC TMP-1103LMP TMP-1103LMPC | TMP-1303M TMP-1303MC TMP-1303LM TMP-1303LMC | TMP-2003M TMP-2003MC TMP-2003LM TMP-2003LMC |
| Exchangeable Compatibility | | The control cable and the motor cable are interchangeable between any pump and power supply unit. | | | | |
| Magnetic Bearing | | 5 axis control. No Battery is required. (When power failure occur, magnetic bearing is support by regenerative power from motor.) | | | | |
| Speed control | | Feedback control | | | | |
| Speed variation | | Speed is variable between 25% and 100% of the rated speed (set as 0.1%). | | | | |
| Display | LCD | 20characters*2 lines (With LED back light) | | | | |
| | LED | POWER / ROTATION / NORMAL SPEED / ALARM | | | | |
| Communication | Contact | REMOTE (MR 34pin) Input : START / STOP / RESET / LOW SPEED Output : ROTATION / ACC. / BRAKE / NORMAL REMOTE / ALARM / WARNING | | | | |
| | Serial | RS-232C (D-sub 9pin male, Screw lock size:M2.6) / RS-485 (D-sub 9pin female, Screw lock size:M2.6) | | | | |
| Alarm Detection | Alarm | Pump Temperature Pump Startup Failure,Overload,Overspin for motor Magnetic Bearing failure Power supply malfunction (Over Temperature inside power supply, Fail drive circuit) Power failure | | | | |
| | Warning | Failure of magnetic bearing | | | | |
| Protection | Alarm | ALARM LED lights, buzzer sounds, alarm description displayed on LCD. Power failure: Decelerates while maintaining magnetic levitation by regenerative braking power. Levitation is stopped after deceleration, and the rotor is supported by the touch-down bearing. Once power is restored, restart is possible after resetting. (Refer to Section 7.2) When other alarms occur: Stops operation or decelerates. Magnetic levitation is continued | | | | |
| | Warning | ALARM LED flashes, buzzer sounds, warning description displayed on LCD.Pump operation continues. | | | | |
| Momentary power failure | | If the electrical power is recovered in 1 second or less, then the power supply operation prior to the electrical power failure is continued. No change output signal.Otherwise, the turbo molecular pump rotor is decelerated. If the power is disrupted over one second, the brake will engage. The pump can be restarted after the reset operation. | | | | |
| Alarm history | | Stores the date, time and detected event information for the last 99 alarm events. | | | | |
| Input electric power | Voltage | Single phase 200 to 240 VAC \pm 10% (50 / 60 Hz \pm 2 Hz) | | | | |
| | Maximum power | 1.0 kVA | 1.0 kVA | 1.0 kVA | 1.2 kVA | |
| | Insulation withstand voltage | 1500 V, 1 minutes | | | | |
| Mass | | 8 kg | | | | |

4.1 Power Supply Unit

| | | | | | |
|---|---|---|-----------|-----------|--|
| Power supply unit model | EI-D1003M | EI-D1103M | EI-D1303M | EI-D2003M | |
| Environmental Conditions | Temperatures | Operation : 0 to 45 °C / Storage : -25 to 70 °C (No dew condensation) | | | |
| | Relative humidity | 40 to 80 %RH | | | |
| Installation conditions (See EN61010-1 standard) | Use : Indoor, Altitude max : 2000 m Overvoltage category III, Pollution degree 2 IP classification 20 | | | | |

| Power supply unit model | EI-D2203M | EI-D2303M | EI-D3203M | EI-D3403M | EI-D4203M |
|----------------------------|---|--|--|-------------|-------------|
| Suitable pump | TMP-2203M TMP-2203MC TMP-2203LM TMP-2203LMC | TMP-W2303LMC | TMP-3203M TMP-3203MC TMP-3203LM TMP-3203LMC | TMP-3403LMC | TMP-4203LMC |
| Exchangeable Compatibility | The control cable and the motor cable are interchangeable between any pump and power supply unit. | | | | |
| Magnetic Bearing | 5 axis control. No Battery is required. (When power failure occur, magnetic bearing is support by regenerative power from motor.) | | | | |
| Speed control | Feedback control | | | | |
| Speed variation | Speed is variable between 25% and 100% of the rated speed (set as 0.1%). | | | | |
| Display | LCD | 20characters*2 lines (With LED back light) | | | |
| | LED | POWER / ROTATION / NORMAL SPEED / ALARM | | | |
| Communication | Contact | REMOTE (MR 34pin) Input : START / STOP / RESET / LOW SPEED Output : ROTATION / ACC. / BRAKE / NORMAL REMOTE / ALARM / WARNING | | | |
| | Serial | RS-232C (D-sub 9pin male, Screw lock size:M2.6) / RS-485 (D-sub 9pin female, Screw lock size:M2.6) | | | |
| Alarm Detection | Alarm | Pump Temperature Pump Startup Failure,Overload,Overspin for motor Magnetic Bearing failure Power supply malfunction (Over Temperature inside power supply, Fail drive circuit) Power failure | | | |
| | Warning | Failure of magnetic bearing | | | |
| Protection | Alarm | ALARM LED lights, buzzer sounds, alarm description displayed on LCD. Power failure: Decelerates while maintaining magnetic levitation by regenerative braking power. Levitation is stopped after deceleration, and the rotor is supported by the touch-down bearing. Once power is restored, restart is possible after resetting. (Refer to Section 7.2) When other alarms occur: Stops operation or decelerates. Magnetic levitation is continued | | | |
| | Warning | ALARM LED flashes, buzzer sounds, warning description displayed on LCD.Pump operation continues. | | | |
| Momentary power failure | If the electrical power is recovered in 1 second or less, then the power supply operation prior to the electrical power failure is continued. No change output signal.Otherwise, the turbo molecular pump rotor is decelerated. If the power is disrupted over one second, the brake will engage. The pump can be restarted after the reset operation. | | | | |
| Alarm history | Stores the date, time and detected event information for the last 99 alarm events. | | | | |

SECTION 4 SPECIFICATIONS

| Power supply unit model | | EI-D2203M | EI-D2303M | EI-D3203M | EI-D3403M | EI-D4203M |
|---|------------------------------|---|-----------|-----------|-----------|-----------|
| Input electric power | Voltage | Single phase 200 to 240 VAC \pm 10% (50 / 60 Hz \pm 2 Hz) | | | | |
| | Maximum power | 1.2 kVA | 1.4 kVA | 1.2 kVA | 1.3 kVA | 1.5 kVA |
| | Insulation withstand voltage | 1500 V. 1 minutes | | | | |
| Mass | | 8 kg | | | | |
| Environmental Conditions | Temperatures | Operation : 0 to 45 °C / Storage : -25 to 70 °C (No dew condensation) | | | | |
| | Relative humidity | 40 to 80 %RH | | | | |
| Installation conditions (See EN61010-1 standard) | | Use : Indoor, Altitude max : 2000 m Overvoltage category III, Pollution degree 2 IP classification 20 | | | | |

4.2 Standards Fulfilled

| | |
|--------|--|
| Safety | EN61010-1; 2001 UL61010A-1 SEMI S2 EN1012-2; 1996 |
| EMC | EN61326-1; 1997 + A1; 1998 + A2; 2001 class A EN61000-3-2; 1995 + A14; 2000 SEMI F47 |

INSTALLATION

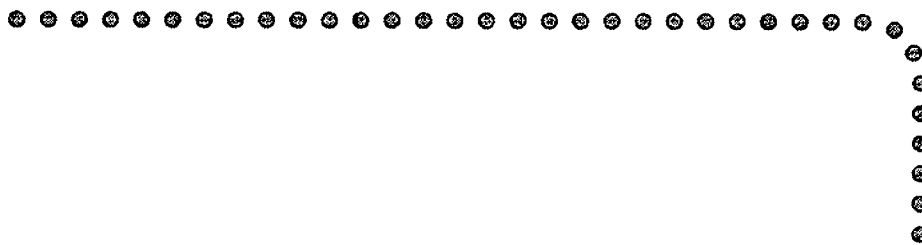

5.1 Installation of the Power Supply Unit

5.1.1 Location of the Power Supply Unit

5.1.2 Installation of the Power Supply Unit

5.1.3 Compatibility with Previous Models

5.2 Connection of Power Cable

5.3 Connection of the Pump to the Power Supply Unit

5.1 Installation of the Power Supply Unit

5.1.1 Location of the Power Supply Unit

Install and anchor the power supply unit inside a rack, which shall be located at a place where it is not exposed to direct sun ray and well ventilated. Avoid to locate it at the following places.

- (1) Place where it is very humid, dusty and, in addition, oil smoke, vapor, water, etc, are exist.
- (2) Place where the power supply unit is exposed to direct sun ray and abnormally high temperature
- (3) Place with high amplitude of vibration and impact
- (4) Near chemically active gas and explosive/combustible gas
- (5) Place with strong magnetic field and electric field, noisy place, and place with strong radioactive ray
- (6) Unventilatable place

5.1.2 Installation of the Power Supply Unit

When mounting the power supply unit onto the customer's rack, use the front panel installation holes. The installation panel and screws are to be supplied by the customer.

Prepare the shelf to support the weight of the power supply unit in the rack.

How to install the unit onto a rack

- (1) Turn the power supply unit over and remove the four rubber pads.
- (2) Pass the power supply unit through the cutout hole in the installation panel and secure it with four screws (See Fig. 5-2).
- (3) In order to ensure that the interior of the power supply unit is cooled sufficiently, leave a gap inside the rack of at least 30 mm above, 5 mm on either side, and 50 mm to the rear of the power supply unit (See Fig. 5-1).
- (4) The space required for installing the cables is shown in Fig. 5-4.
- (5) Reattach the rubber pads if necessary.

5.1 Installation of the Power Supply Unit

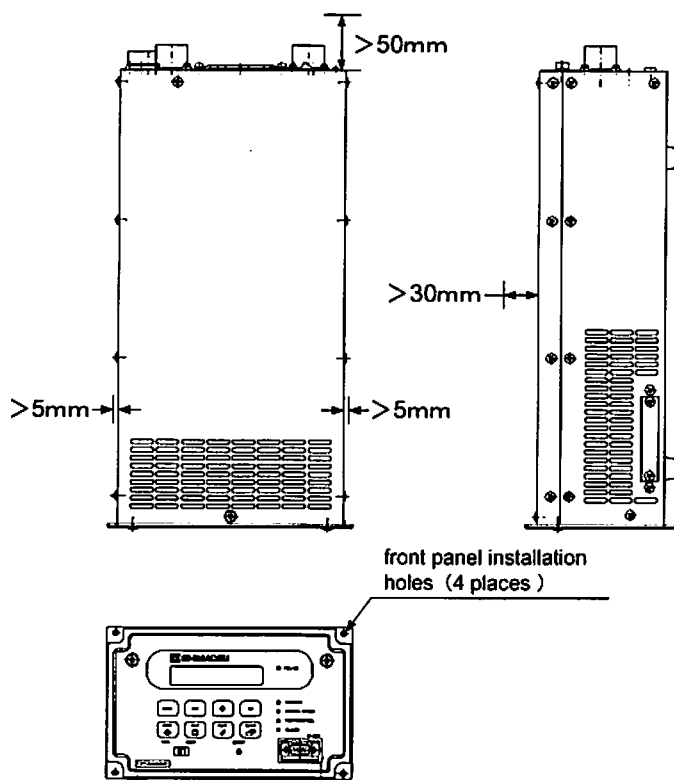

Fig.5-1 Leave enough space around the power supply unit

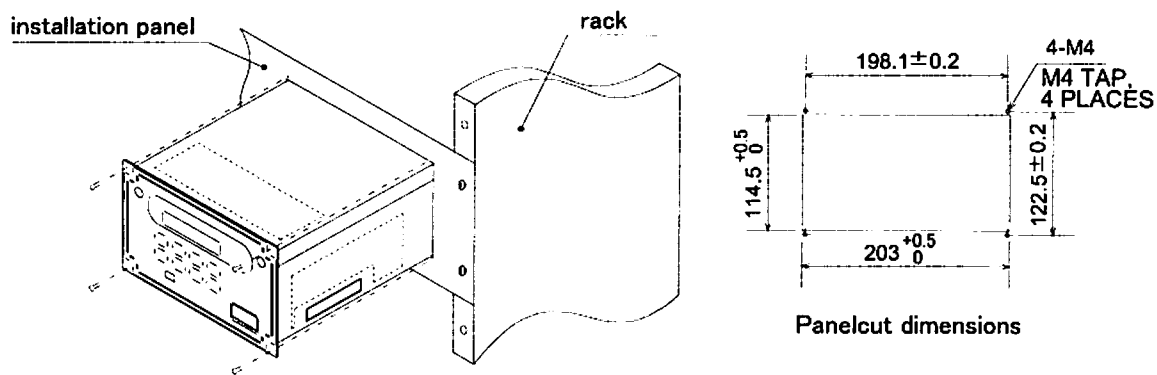

Fig.5-2 Mount the power supply unit

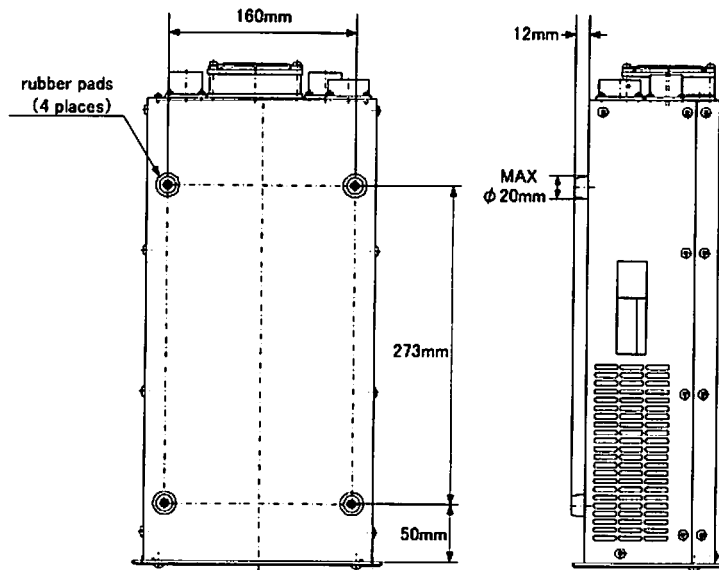
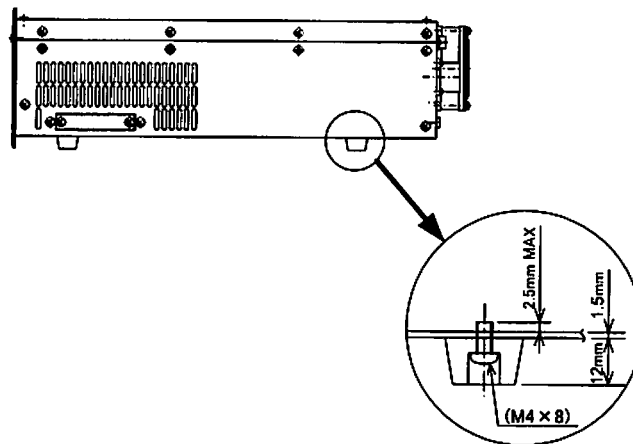

Fig.5-3 Location of rubber pads



(Note 1) Use the prescribed screws to attach the rubber pads. Using the wrong screws can lead to damage or failure of the power supply unit.

Fig.5-4 Attaching the rubber pads

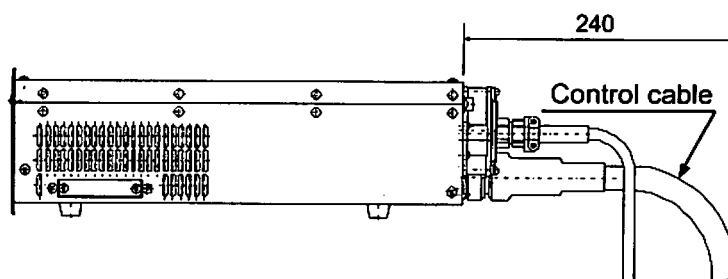

Fig.5-5 Space to connect the cable

5.1.3 Compatibility with Previous Models

If previous EI-xx03M/MD/MZ power supply units (where "xx" is a number that indicates the applicable pump type) are being used installed on a rack, then optional rack mounting kit is required in order to replace these units with EI-Dxx03M power supply units.

The mounting screws are to be supplied by the customer.

Prepare the shelf to support the weight of the power supply unit in the rack.

Optional Parts (Rack Mounting Kit)

| | Description | Q'ty | Notes | Parts Number |
|---|-------------------------|------|--|--------------|
| 1 | Rack Mounting Panel | 1 | Steel, painted same color as front panel of power supply unit. (See Fig.5-5) | 263-14117 |
| 2 | Panel Attachment Screws | 4 | Stainless Steel, M4 L=6mm | |

How to install the unit onto the rack :

- (1) Turn the power supply unit over and remove the four rubber pads.
- (2) Attach the rack mounting panel to the power supply unit with four Panel Attachment Screws. (See Fig. 5-7)
- (3) Reattach the rubber pads of the power supply unit if they are necessary.
- (4) Fix to the rack using 4 M4 tap screws. (See Fig. 5-7, Fig. 5-8)

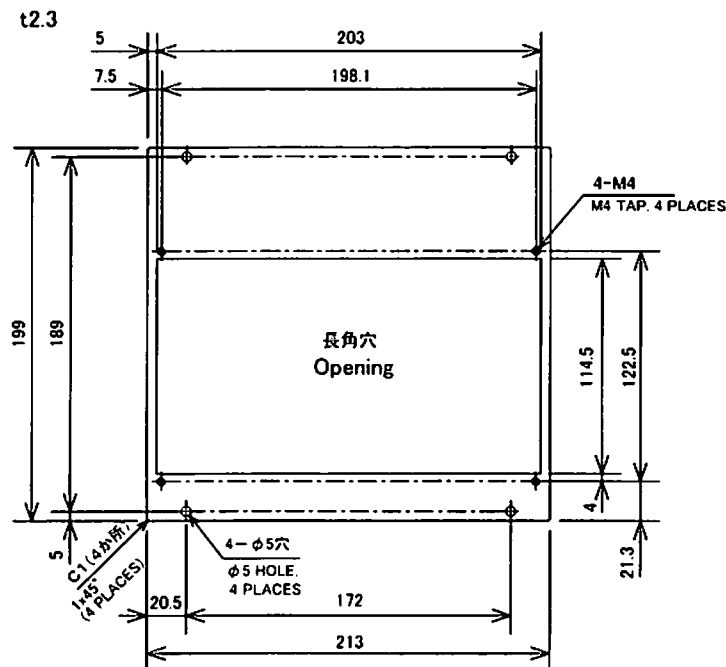

Fig.5-6 Dimensions of Rack Mounting Panel

SECTION 5 INSTALLATION

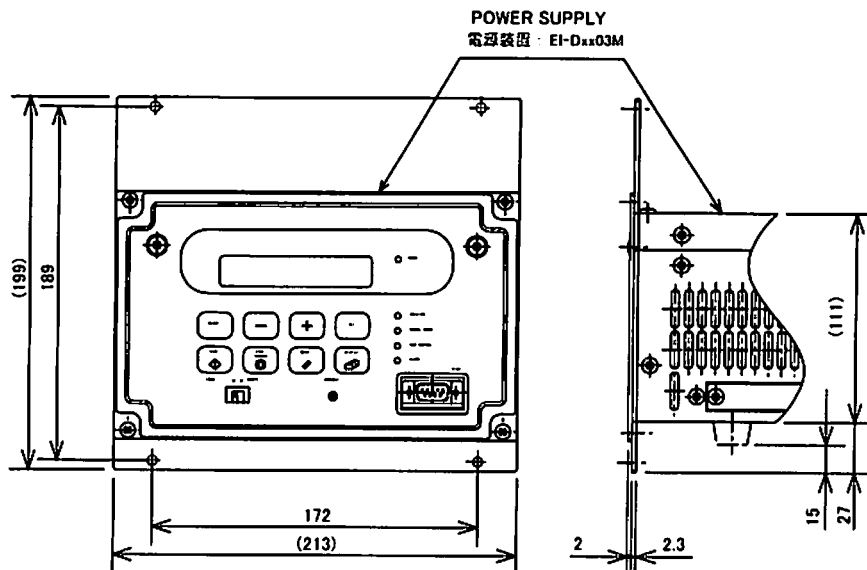

Fig.5-7 Dimensions of the Power Supply Unit with Rack Mounting Panel

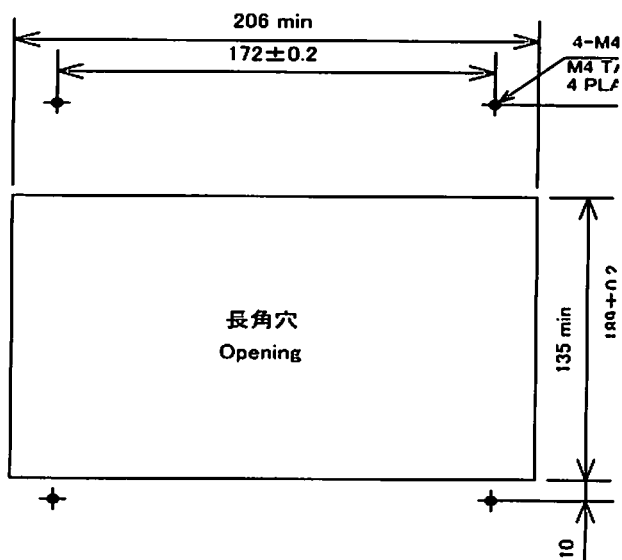

Fig.5-8 Panelcut Dimensions

If a remote-control signal is used, it must be checked for compatibility. For a detailed procedure, please refer to Section 6.7.1 "Compatibility with Previous Models".

5.2 Connection of Power Cable

NOTICE

The power input voltage of the power supply unit EI-Dxx03M (the "xx" number indicates the model of the corresponding pump) is 200 to 240 VAC \pm 10%. Connect the power supply unit to the voltage specified on the rear panel label only. Connection of the power supply unit to the incorrect input voltage can cause damage to the equipment. Supply the power via a breaker (rating 15A). Please provide PE(Protective Earth) connection to the terminal of a "PE" marked wire in final application.

5

Connection of Power Cable:

(1) Connect the power cable terminal to the terminal board of user's power distribution board for equipment. The wire with [PE] mark is for earth use and other remaining two wires are for single phase AC power. (See Fig. 5-9, Table 5-1)

First, connect the wire [PE] mark. Next connect the other two wires.

(2) Turn off the POWER switch (Fig. 2-2 (17)) on the rear panel of the power supply unit. Or otherwise be sure to check that it is in off.

(3) Connect the power cable connectors to the power supply unit AC INPUT connector (Fig. 2-2 (16)).

REFERENCE

For the specified power voltage, see the side panel of the power supply unit.

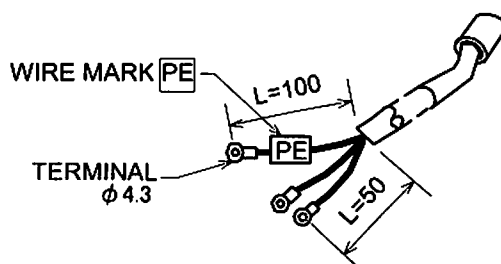

Fig.5-9 Power Cable

Table 5-1 Power Cable CONNECTION

| Wire color of power cable | | Green/Yellow | Black | White |
|---------------------------|----|--------------|-------|-------|
| Location | EU | PE | N | L |
| | US | GND | L2 | L1 |

5.3 Connection of the Pump to the Power Supply Unit

NOTICE

Insert straight the control cable connector after checking its key direction. Inserting it in oblique direction would cause damage of the connector pins. After the insertion, turn the cable connector clockwise until the rotation lock clicks.

NOTICE

Don't disconnect each cable while the pump is running. Particularly before disconnecting the control cable, Check complete shutdown of the pump by ROTATION lamp goes out and, thereafter, turn off the POWER switch.

Control Cable:

Use the control cable that conformed CE marking. It has ferrite core at power supply side. Control cables available for the use are identified with "262-75369A". But, If no ferrite core is not fixed around a control cable, it is not conformed CE marking.

Check that it is identified as specified. Even the use of other similar cable would disable start-up of the pump, even though it could be connected. After turn on the POWER switch of the power supply unit, ALARM lamp (Fig. 2-1 (14)) lights, if an old type cable is connected.



Fig.5-10 Control Cable

Connecting Sequence (See Fig. 2-2 and Fig. 5-10):

- (1) Turn off the POWER switch (Fig. 2-2 (17)) on the rear panel of the power supply unit. Or otherwise check that it is off.
- (2) Connect the power supply unit to the control connector (Fig. 2-2 (19)) of the pump proper with the control cable.
- (3) Connect the power supply unit to the motor connector (Fig. 2-2 (20)) of the pump proper with the motor cable.
- (4) For remote operation of the turbo molecular pump or intake of status signal, etc., connect the RS-485 connector (Fig. 2-2 (21)) or RS-232C connector (Fig. 2-2 (22)), Remote-Control connector (Fig. 2-2 (23)). When using Remote-Control connector, make wiring connection as instructed in Section 6.7 "Remote-Control Connector".

All interfaces are SELV(Safety extra-low Voltage).

5.3 Connection of the Pump to the Power Supply Unit

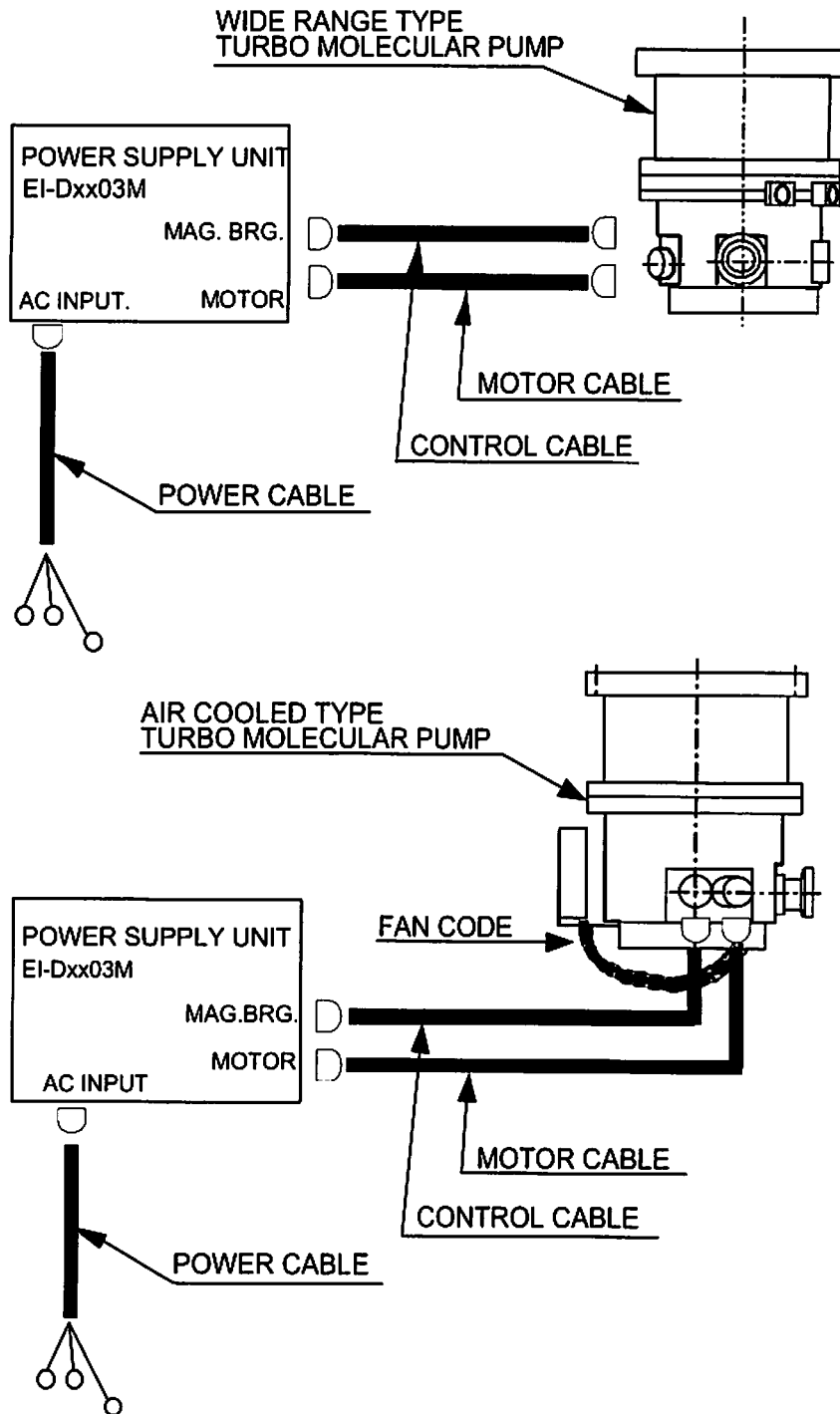

5

Fig.5-11 Connection of Cables

This page is intentionally left blank.

OPERATION

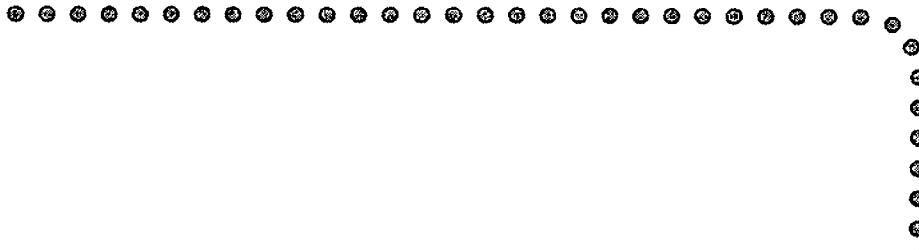

- 6.1 Outline
 - 6.1.1 Introduction
 - 6.1.2 Operation Flowchart
- 6.2 Start-up Preparation
 - 6.2.1 Start-up Preparation Sequence in LOCAL Mode
 - 6.2.2 Start-up Preparation Sequence in REMOTE Mode
- 6.3 Start-up
 - 6.3.1 Start-up Sequence in LOCAL Mode
 - 6.3.2 Start-up Sequence in REMOTE Mode
- 6.4 Shutting Down
- 6.5 Variable Speed Operation
 - 6.5.1 Outline
 - 6.5.2 Operation from Start-up to Low Speed Rotation
 - 6.5.3 Operation from Rated Speed Rotation to Low Speed Rotation
 - 6.5.4 Operation from Low Speed Rotation to Rated Speed Rotation
- 6.6 Software Operation
- 6.7 Remote-Control Connector
 - 6.7.1 Specifications
 - 6.7.2 Compatibility with Previous Models

6.1 Outline

CAUTION

Neither disconnect and reconnect each cable while the pump is running. Particularly for unplugging the control cable from the receptacle, check complete shutdown of the pump by ROTATION lamp goes out and, thereafter, turn off the POWER switch.

CAUTION

Do not turn the power off while the pump is running. The touch-down bearing may need to be replaced if the power is turned off repeatedly during operation. When the power is turned off while the pump is rotating, power from regenerative braking maintains the magnetic levitation until the rotational speed drops. Levitation then stops and the touch-down bearing supports the rotor. Consequently, repeated touch-down operations can reduce the life of the bearing.

6.1.1 Introduction

(See Fig. 2-1 and Fig. 2-2)

The LCD (Fig. 2-1 (1)) displays the model name of the power supply unit corresponding to the pump model name (e.g. SHIMADZU EI-Dxx03M) when the power supply unit POWER switch (Fig. 2-2 (17)) is turned on.

It then displays "SELF CHECKING" and the power supply unit conducts self-diagnosis. If the result is good, the LCD changes into monitor mode (See section 6.6 Software Operation (1)), and the power supply is operatable. But if an alarm is detected, the LCD changes into alarm mode (See Section 6.6 Software Operation (2)), and displays detected alarm.

6.1.2 Operation Flowchart

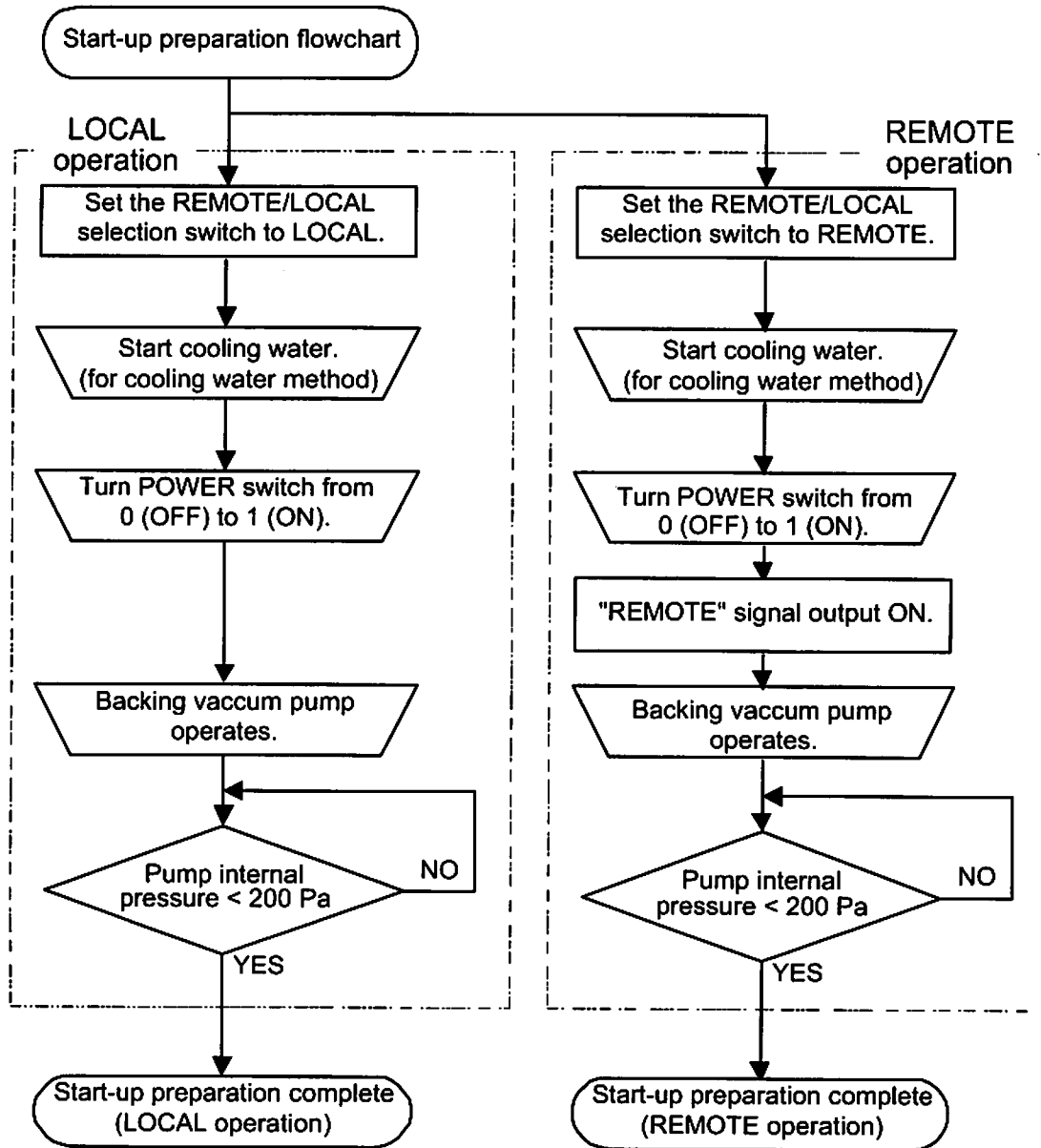

Fig. 6-1 Start-up Preparation Flowchart

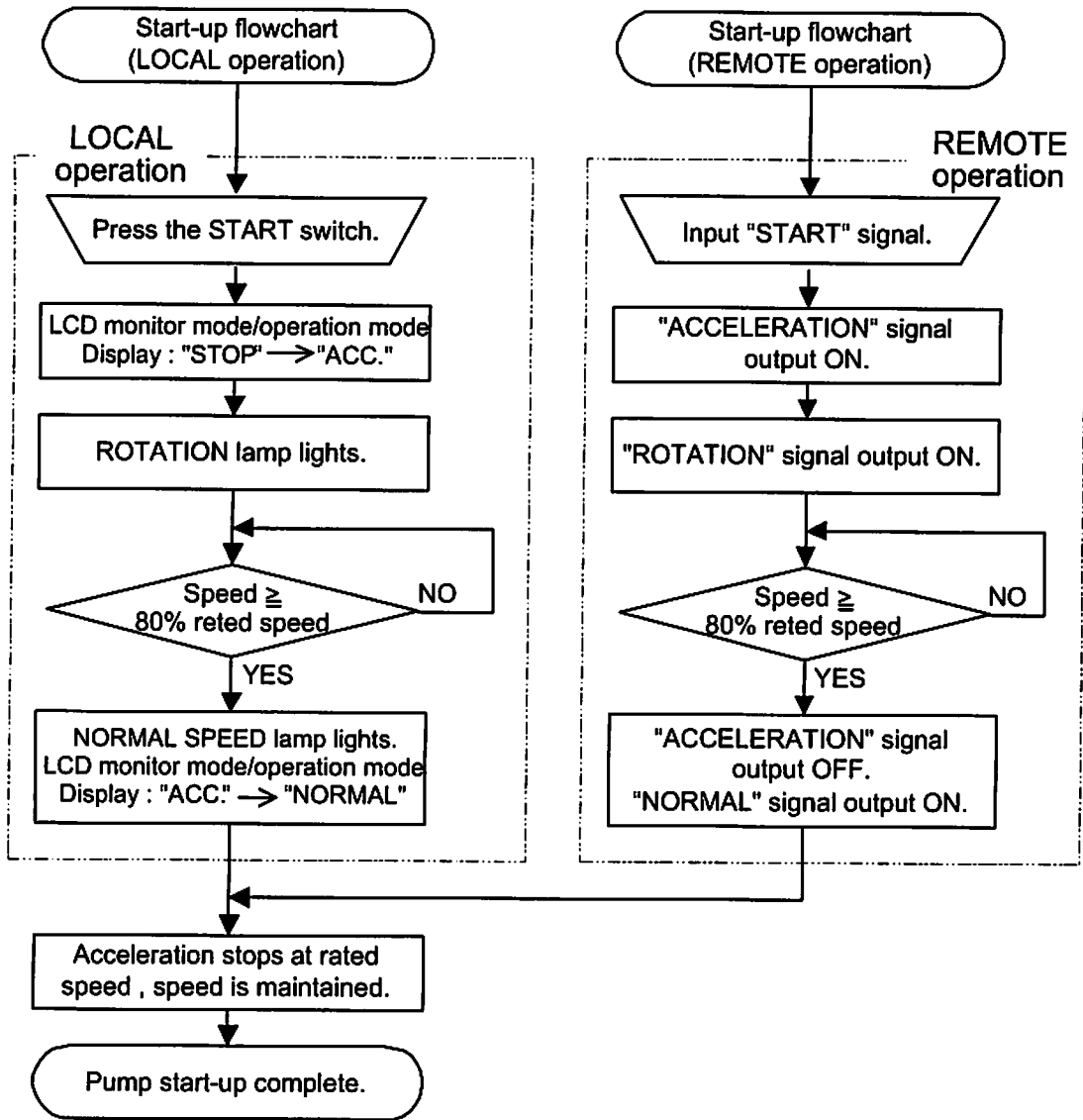

Fig. 6-2 Start-up Flowchart

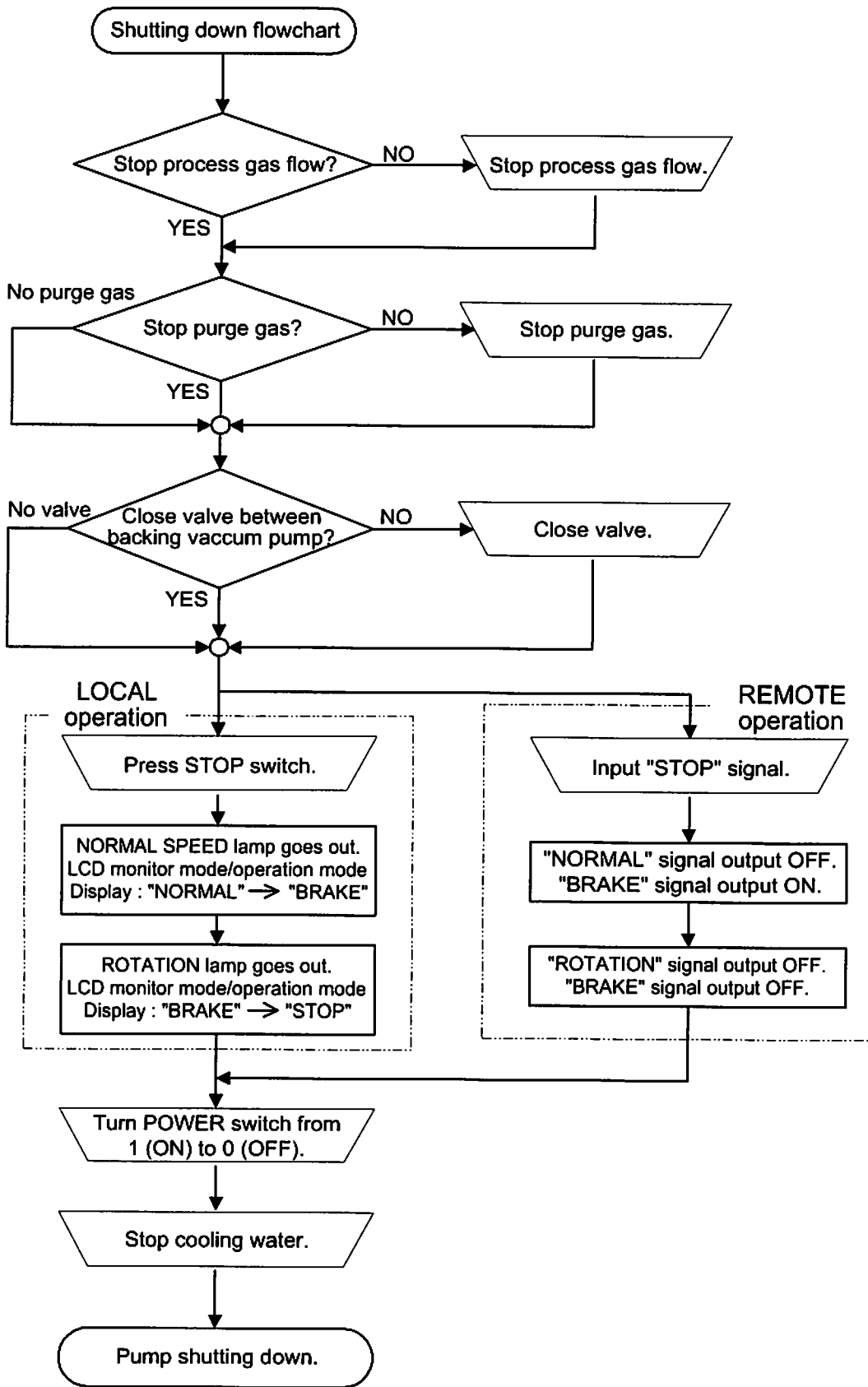
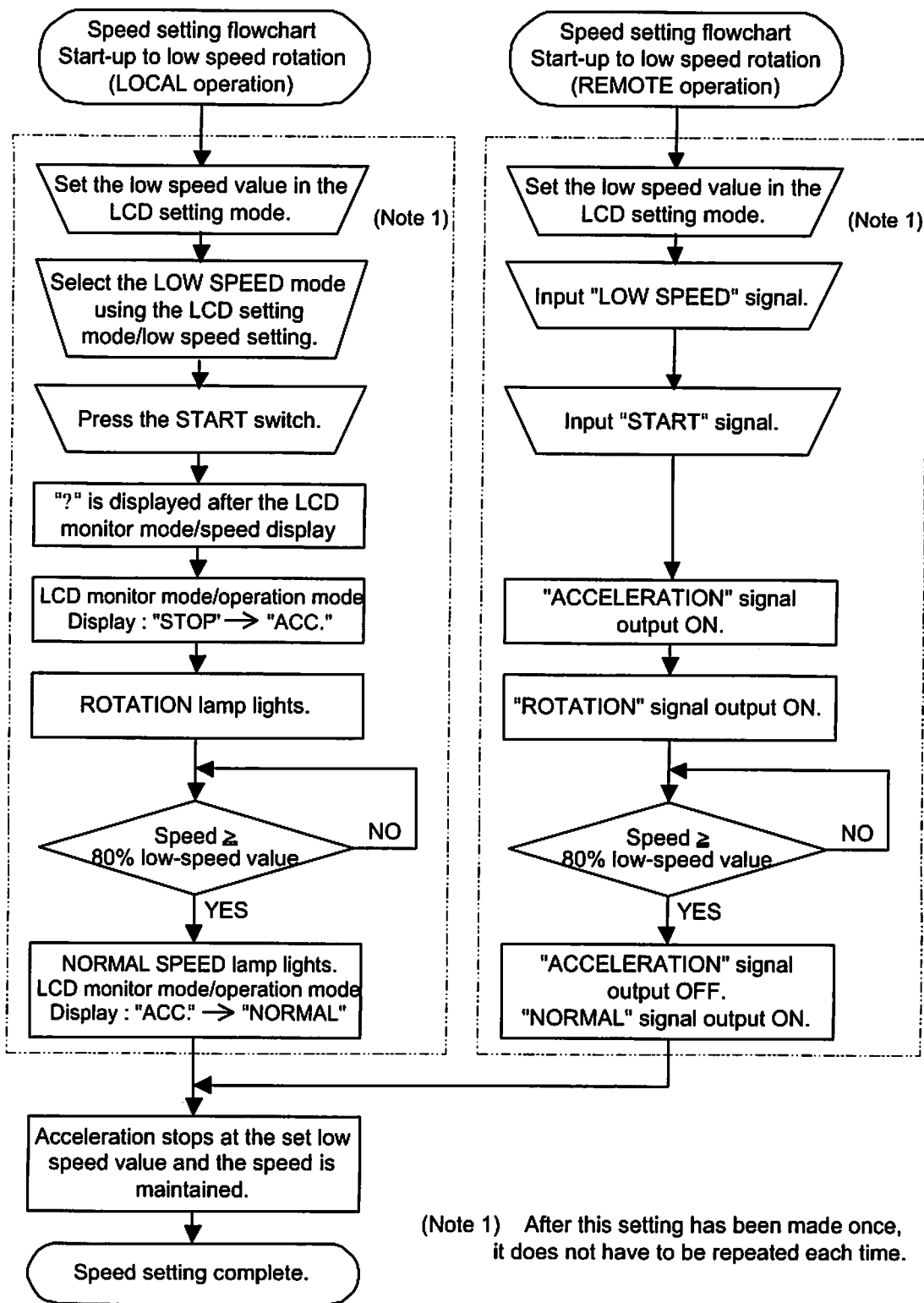
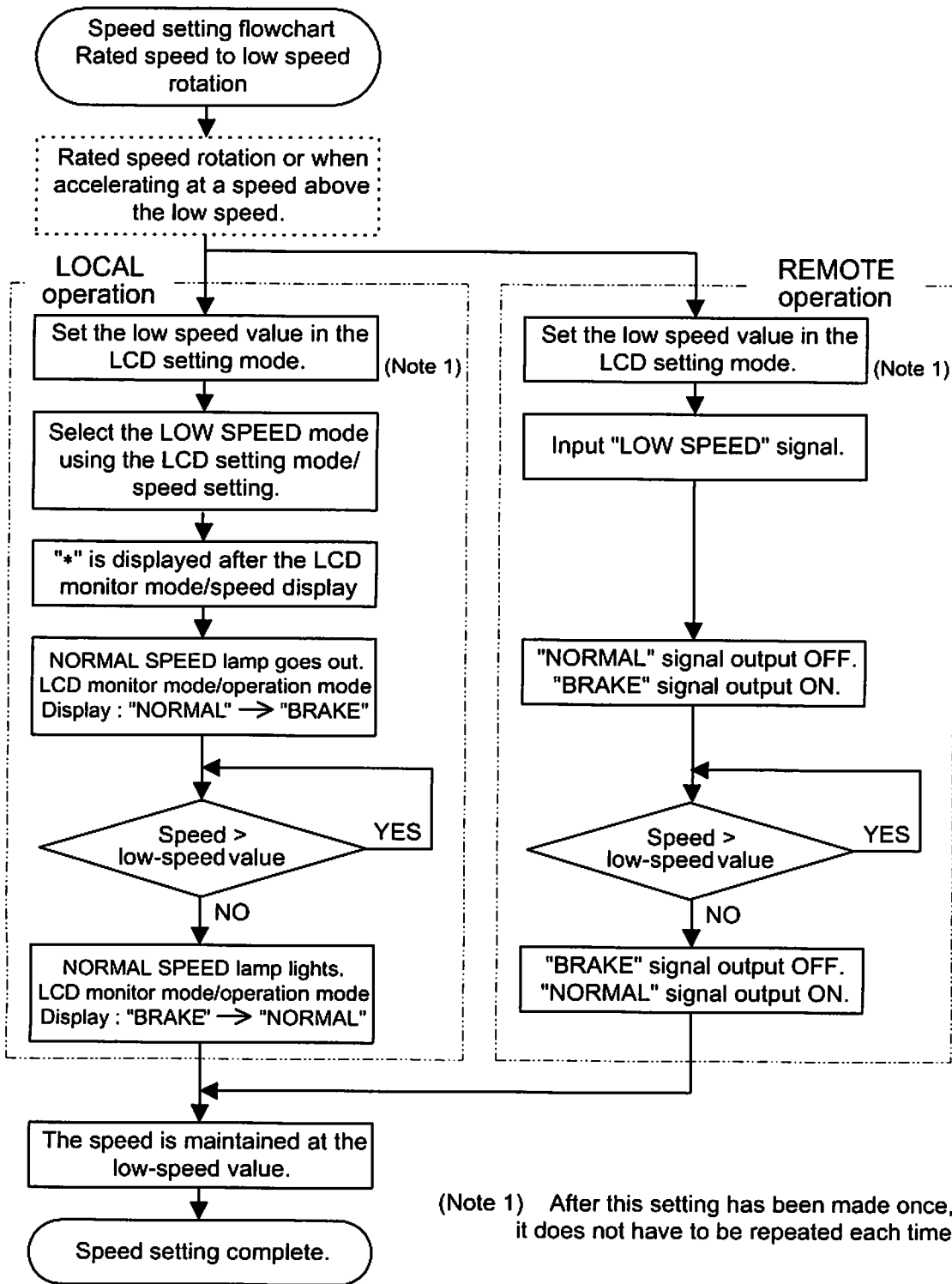

Fig. 6-3 Shutting down Flowchart



Start-up to Low Speed Rotation
Fig. 6-4 Speed Setting Flowchart



Rated Speed to Low Speed Rotation
Fig. 6-5 Speed Setting Flowchart

SECTION 6 OPERATION

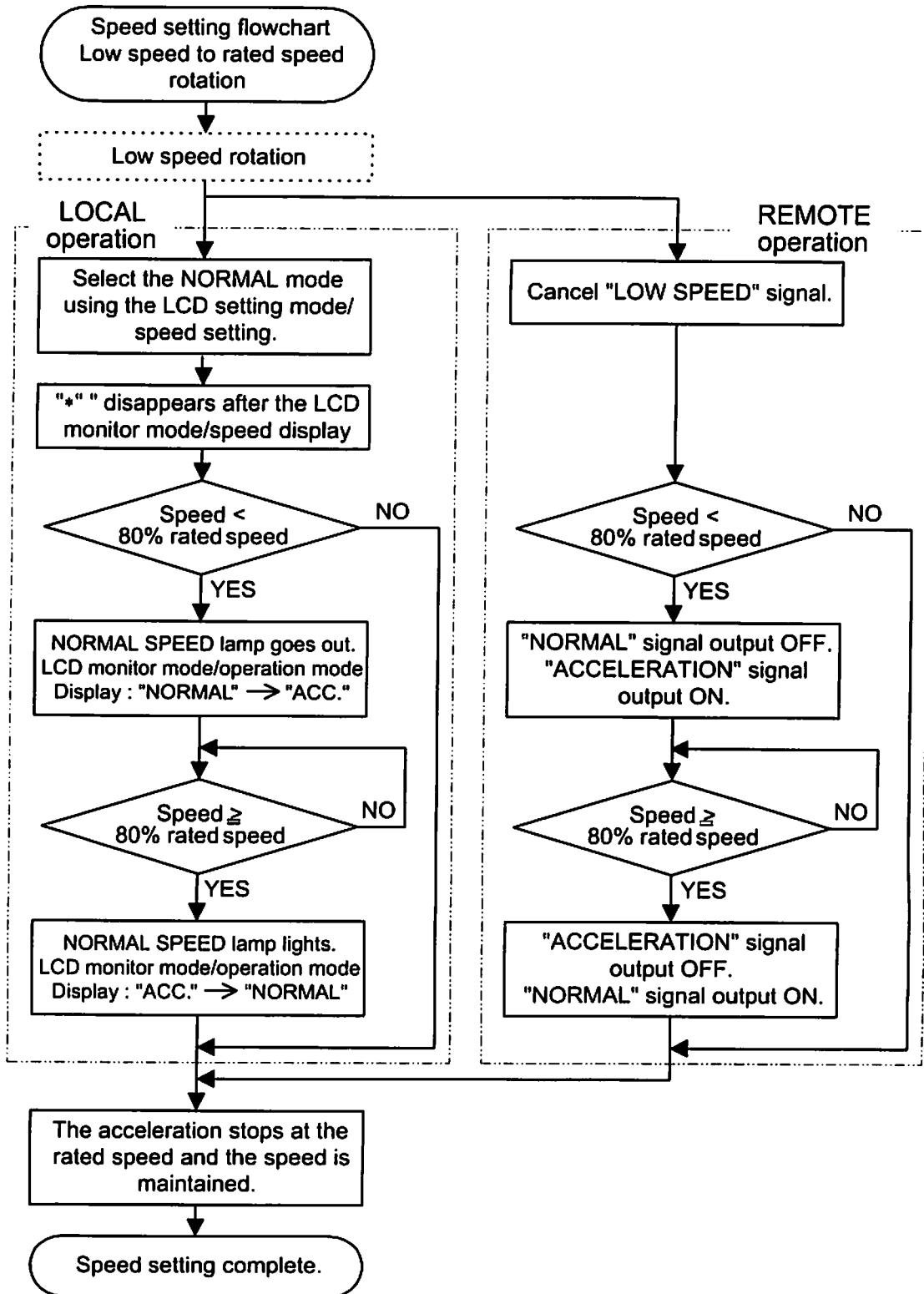

Low Speed to Rated Speed Rotation
Fig. 6-6 Speed Setting Flowchart

6.4 Shutting Down

CAUTION

After having operated the turbo molecular pump for evacuation of corrosive gas, keep the pump internal as vacuumed even after shutdown. Inflow of water content in the air to the pump internal would cause rapid corrosion trouble of the pump internals. The pump corrosion may result in damaging the vacuum vessel interior and other units, causing pressure fluctuation by stopping the pump and dispersal of parts.

CAUTION

When reducing internal pressure of the turbo molecular pump up to around the atmospheric pressure by use of inert gas, etc., adjust the pressure reducing valve so that the internal pressure of the same pump does not exceed 20 kPa [GAUGE].

For shut-down of the turbo molecular pump, follow the sequence below.

6.4.1 Preparations Prior to Shutting Down Operation

- (1) Check that process gas inflow is in complete stop. When main valve is provided between the turbo molecular pump and vacuum chamber, close the valve, too.
- (2) When purge gas is being fed into the turbo molecular pump, stop the gas feed, too.
- (3) When forevacuum valve is provided between the turbo molecular pump and backing vacuum pump, close the valve, too.

6.4.2 Shutting Down Sequence in LOCAL Mode

- (1) Press the STOP switch (Fig. 2-1 (7)) and check that the indication on the pump monitor mode/operation mode LCD switches from "NORMAL" to "BRAKE."
Then the NORMAL SPEED lamp (Fig. 2-1 (12)) goes off.
- (2) Wait until the ROTATION lamp (Fig. 2-1 (11)) goes out. The pump monitor mode/operation mode LCD switches from "BRAKE" to "STOP."
- (3) Turn off the power supply unit POWER switch (Fig. 2-2 (17)).
- (4) Stop the cooling water flow.

6.4.3 Shutting Down Sequence in REMOTE Mode

- (1) Input the "STOP" signal (see Table 6-3) from the remote-control connector (Fig. 2-2 (24)) and check that the "BRAKE" signal (see Table 6-3) is ON.
- (2) Wait until the "ROTATION" signal (see Table 6-3) turns OFF. At this time, the "BRAKE" signal (see Table 6-3) also turns OFF.
- (3) Turn off the power supply unit POWER switch (Fig. 2-2 (17)).
- (4) Stop the cooling water flow.

When the turbo molecular pump is turned off after pumping a corrosive gas, maintain a vacuum inside the turbo molecular pump or purge the interior of the pump with an inert gas.

Further, in such a case when a hydraulic rotary vacuum pump is used as backing vacuum pump and there is possible reverse flow and diffusion of oil from the backing vacuum pump, return the pump internal pressure to atmospheric pressure using dry nitrogen gas, after complete shut-down of the pump [ROTATION lamp (Fig. 2-1 (11)) goes out], to prevent the turbo molecular pump from being contaminated with oil vapor.

For shutting down the turbo molecular pump in running at high speed with infeed of dry nitrogen gas to the pump, keep the nitrogen gas flow rate at 1500 mL/min maximum.

REFERENCE

ROTATION lamp (Fig. 2-1 (11)) goes out or "ROTATION" signal (see Table 6-3) turns off when the pump rotational speed is 60rpm or less. Turning off the POWER switch (Fig. 2-2 (17)) permits the pump rotor to be supported by the touch-down bearings.

6.5 Variable Speed Operation

CAUTION

When using the variable speed function to change the pump rotation rate, use a rotation rate that does not cause resonance with other devices installed at the site.

6

CAUTION

If an EI-Dxx03M power supply unit is used in combination with an existing pump that was operated in combination with a power supply unit not having the variable speed function (EI-xx03MD), the variable speed function cannot be used. (the "xx" number indicates the model of the corresponding pump.)

If the power supply unit is to be combined with an existing pump, modification and operational inspections are necessary. Please contact Shimadzu for detailed information.

6.5.1 Outline

- (1) The rotational speed settings function sets the rotational speed by selecting between the NORMAL speed mode or LOW SPEED mode.
- (2) Select the NORMAL mode or LOW SPEED mode by LOCAL operation using the setting mode/rotational speed settings/speed setting set value on the LCD display or by REMOTE operation using the remote-control connector "LOW SPEED" signal input (see Table 6-3).
- (3) The NORMAL mode or LOW SPEED mode selection can be made before or after start-up. (See the Speed Setting Flowcharts in Figs. 6-4, 6-5, and 6-6.)
- (4) Set the low speed value between 25% and 100% of the rated speed in 0.1% increment with the setting mode/rotational speed settings/low speed setting set value on the LCD display.
- (5) The low speed value can be set while the pump is rotating in the LOW SPEED mode. The pump then accelerates or decelerates to the new set value and maintains the set speed.
- (6) The time required for the speed to change is the same as the time for normal acceleration or deceleration.

For example, if the low speed value is set to 80% and the LOW SPEED mode is selected during normal rotation, the time for the speed to drop to 80% is approximately one-fifth the time required to stop from rated speed.

6.5.2 Operation from Start-up to Low Speed Rotation

This is the procedure until low-speed rotation is achieved when the speed setting is made with the pump stopped.

LOCAL Operation

- (1) Start-up begins when the 6.2.1 "Start-up Preparation Sequence in LOCAL Mode" is complete.
- (2) Set the low speed value with the setting mode/rotational speed settings/low speed setting set value on the LCD display. (See Section 6.6 "Software Operation" (4).) After this setting has been made once, it does not have to be repeated each time.
- (3) Select the LOW SPEED mode using the setting mode/rotational speed settings/low speed setting set value. (See Section 6.6 "Software Operation" (4).)
- (4) Press the START switch (Fig. 2-1 (6)).
- (5) While the speed is changing, "*" is displayed after the monitor mode/speed display. (See Section 6.6 "Software Operation" (1).)
- (6) ACC is displayed on the pump monitor mode/operation mode LCD and the pump starts to accelerate. After a few seconds the ROTATION lamp (Fig. 2-1 (11)) lights.
- (7) When the rotational speed reaches 80% of low-speed value, the NORMAL SPEED lamp lights (Fig. 2-1 (12)) and the pump monitor mode/operation mode LCD switches from "ACC." to "NORMAL".
- (8) When the pump speed reaches the set low speed value, acceleration stops and the pump speed is maintained.

※ The same operation occurs if the LOW SPEED mode is selected after the START switch is pressed but before the pump speed reaches the set low speed value.

REMOTE Operation

- (1) Start-up begins when the 6.2.2 "Start-up Preparation Sequence in REMOTE Mode" is complete.
- (2) Set the low speed value with the setting mode/rotational speed settings/low speed setting set value on the LCD display. (See Section 6.6 "Software Operation" (4).) After this setting has been made once, it does not have to be repeated each time.
- (3) Input the "LOW SPEED" signal (see Table 6-3) from the remote-control connector (Fig. 2-2 (23)).
- (4) Input the "START" signal from the remote-control connector (Table 6-3).
- (5) The pump starts to accelerate when the "ACCELERATION" signal (see Table 6-3) from the remote-control connector (Fig. 2-2 (23)) turns ON. After a few seconds the "ROTATION" signal turns ON.
- (6) When the rotational speed reaches 80% of low speed value, the remote-control connector "ACCELERATION" signal turns OFF and the "NORMAL" signal turns ON.
- (7) When the pump speed reaches the set low speed value, acceleration stops and the pump speed is maintained.

※ The same operation occurs if the "LOW SPEED" signal is input after the "START" signal is input but before the pump speed reaches the set low speed value.

6.5.3 Operation from Rated Speed Rotation to Low Speed Rotation

This is the procedure to select low speed operation during rated speed rotation or when accelerating at a speed above the low speed.(see Fig. 6-5)

LOCAL Operation

- (1) Set the low speed value with the setting mode/rotational speed settings/low speed setting set value on the LCD display. (See Section 6.6 "Software Operation" (4).) After this setting has been made once, it does not have to be repeated each time.
- (2) Next, select the LOW SPEED mode using the setting mode/rotational speed settings/speed setting set value on the LCD display. (See Section 6.6 "Software Operation" (4).)
- (3) While the speed is changing, "*" is displayed after the monitor mode/speed display. (See Section 6.6 "Software Operation" (1).)
- (4) The pump monitor mode/operation mode LCD switches from "NORMAL" to "BRAKE" and the pump starts to decelerate. Then the NORMAL SPEED lamp (Fig. 2-1 (12)) goes off.
- (5) When the rotational speed reaches the set low speed value, the NORMAL SPEED lamp lights and the pump monitor mode/operation mode LCD switches from "BRAKE" to "NORMAL."
- (6) The pump stops decelerating and the pump speed is maintained.

※ A normal start-up and normal operation occurs if the mode is reverted to NORMAL speed before the pump speed reaches the set low speed value.

REMOTE Operation

- (1) Set the low speed value with the setting mode/rotational speed settings/low speed setting set value on the LCD display. (See Section 6.6 "Software Operation" (4).) After this setting has been made once, it does not have to be repeated each time.
- (2) Input the "LOW SPEED" signal (see Table 6-3) from the remote-control connector (Fig. 2-2 (23)).
- (3) The pump starts to decelerate when the remote-control connector "NORMAL" signal (see Table 6-3) turns OFF and the "BRAKE" signal (see Table 6-3) turns ON.
- (4) When the pump speed reaches the set low speed value, the remote-control connector "BRAKE" signal turns OFF and the "NORMAL" signal turns ON.
- (5) The pump stops decelerating and the pump speed is maintained.

※ A normal start-up and normal operation occurs if the "LOW SPEED" signal is cancelled before the pump speed reaches the set low speed value.

6.5.4 Operation from Low Speed Rotation to Rated Speed Rotation

This is the procedure to select normal speed operation during low speed rotation.
(see Fig. 6-6)

SECTION 6 OPERATION

LOCAL Operation

- (1) Select the NORMAL mode using the setting mode/rotational speed settings/speed setting set value on the LCD display. (See Section 6.6 "Software Operation" (4).)
- (2) The "*" disappears after the monitor mode/speed display. (See Section 6.6 "Software Operation" (1).)
- (3) If the set low speed value did not exceed 80% rated speed, the pump monitor mode/operation mode LCD switches from "NORMAL" to "ACC." and the pump starts to accelerate. The NORMAL SPEED lamp (Fig. 2-1 (12)) goes off.

When the rotational speed reaches 80% rated speed, the NORMAL SPEED lamp lights and the pump monitor mode/operation mode LCD switches from "ACC." to "NORMAL."

- (4) If the set low speed value exceed 80% rated speed, the LCD display remains unchanged and the pump accelerates.
- (5) When the rated speed is reached, the pump stops accelerating and the pump speed is maintained.

REMOTE Operation

- (1) Cancel the "LOW SPEED" signal (See Table 6-3) inputted in the remote-control connector (Fig. 2-2 (23)).
- (2) If the set low speed value did not exceed 80% rated speed, the remote-control connector "ACCELERATION" signal turns ON and (see Table 6-3) and the pump starts to accelerate. The "NORMAL" signal turns OFF. When the rotational speed reaches 80% rated speed, the remote-control connector "ACCELERATION" signal turns OFF and the "NORMAL" signal turns ON (see Table 6-3).
- (3) If the set low speed value exceed 80% rated speed, remote-control signals remain unchanged and the pump accelerates.
- (4) When the rated speed is reached, the pump stops accelerating and the pump speed is maintained.

6.6 Software Operation

The software operation functions are listed in Table 6-1.

Table 6-1 Software Operation Functions

| Function | Description | Reference flowchart | |
|---|--|---------------------|------------|
| Operation mode User memo Operation status Motor speed Motor current Magnetic bearing monitor (Note 1) | Monitors pump operation status | (1) Monitor mode | |
| Alarm and warning display | Displays details of alarms and warnings. | (2) Alarm mode | |
| Alarm and warning history and details | Display the alarm and warning history. | | |
| Run time Maintenance call time Number of power failure touch-downs Number of high-speed touch-downs Number of magnetic bearing warnings | Resets times and counters. | Menu mode | (3)Timer |
| User memo setting | Inputs user memo. | | (4)Setting |
| RS-232C setting | Sets the communication environment. | | |
| RS-485 setting | Sets the communication environment. | | |
| Rotational speed setting | Sets the pump speed display format. | | |
| Remote-control signal setting | Sets the operations of the remote-control signals. | | |
| Warning output setting (Note 2) | External output setting for warnings | | |
| Default setting | Reverts to the default settings. | | |

(Note 1) When during the low speed rotation (less than 50% of rated speed), or detected alarm below, the monitor function do not operate.

Alarm code:46,47(rotational speed error), 51 to 55(excessive vibration of the magnetic bearing), 66(magnetic bearing control error), 68,69(rotor is out of balance)
(see Table 7-6)

(Note 2) The warning output setting function is installed in some custom-specification instruments; it is not available in all instruments. Modifications are required to install this function in an instrument that does not incorporate it. Consult your Shimadzu representative for details.

SECTION 6 OPERATION

A flowchart of the entire LCD display is shown below.

SELECT, **+**, **-**, **SET** in the flowchart indicate keys on the power supply unit front panel represent the LCD display.

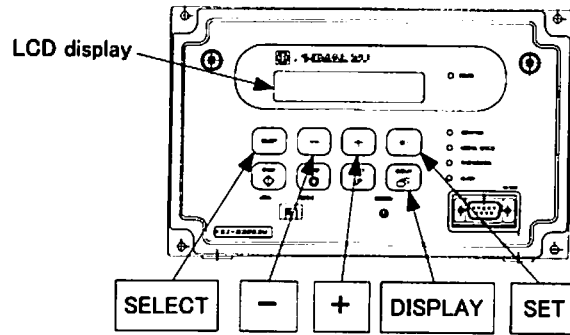
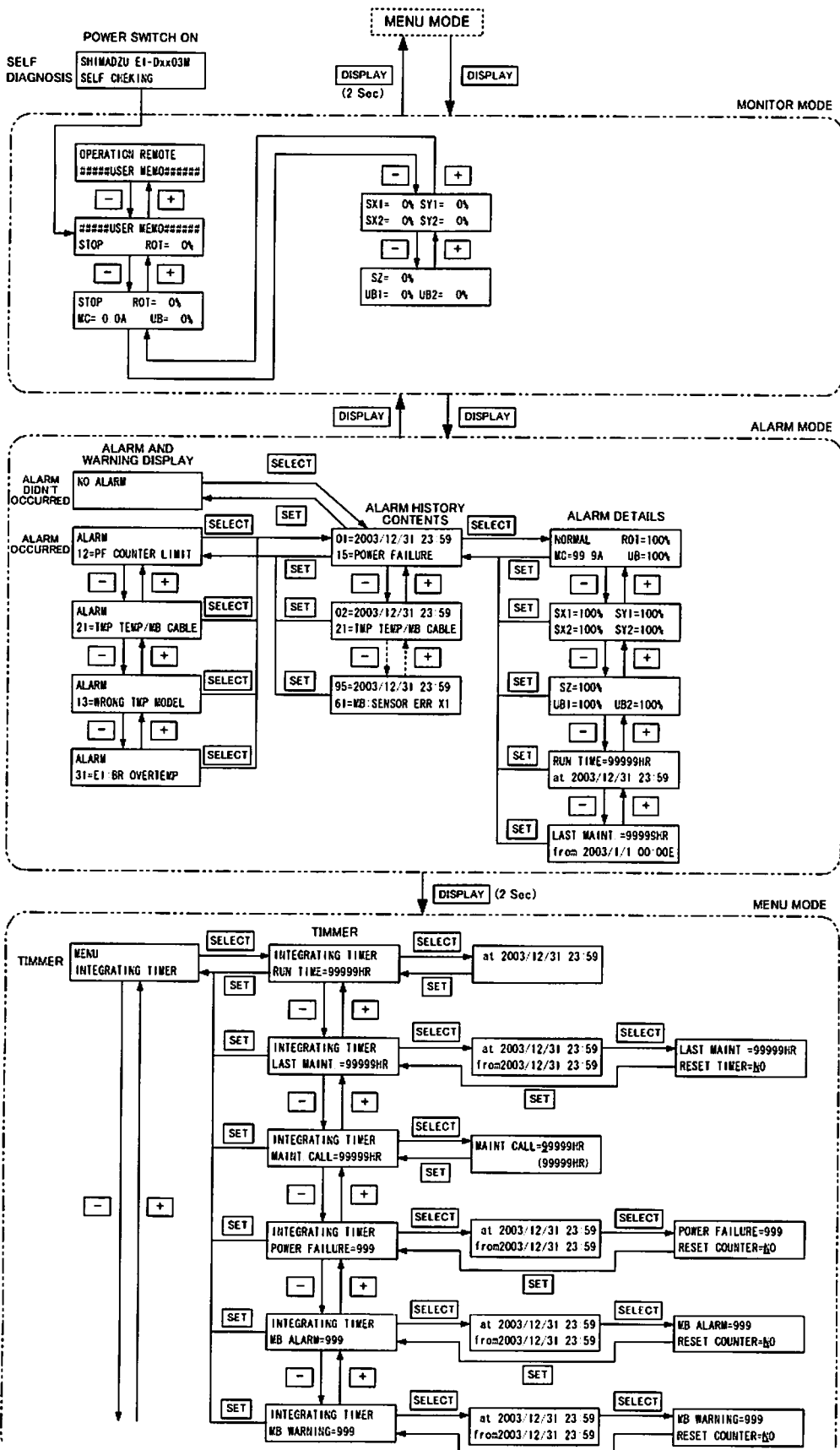

Fig. 6-7 Power Supply Unit Front Panel



Detail
→ P47

Detail
→ P49

Detail
→ P50

SECTION 6 OPERATION

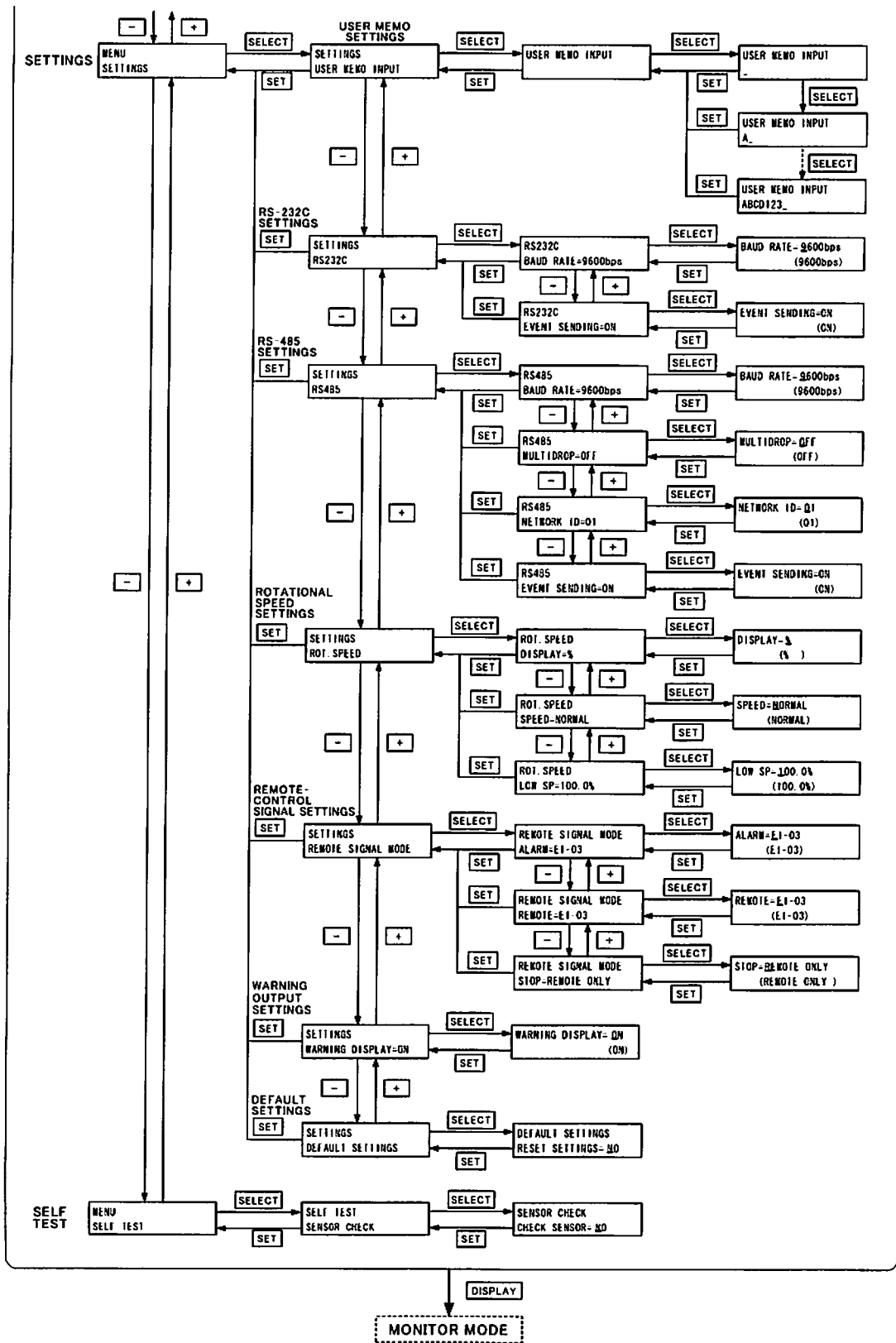

In the next tables, they are shown detailed flowchart of LCD display.

(1) MONITOR MODE

In monitor mode operation status of pump can be identified. If key DISPLAY is pushed in menu mode, the LCD changes into monitor mode. The LCD changes automatically into monitor mode after start or stop operation.

| Mode | Operation and LCD Display | Description of Display |
|-----------|---------------------------|------------------------|
| MONITOR 1 | | |
| MONITOR 2 | | |
| MONITOR 3 | | |
| MONITOR 4 | | |
| MONITOR 5 | | |

First, Monitor 2 display following to initial display after power switch turning on.

(Note 1) Operation Mode

| LCD Display | Operation |
|-------------|---|
| LOCAL | Control by a manual switch operation on the front panel |
| REMOTE | Control by a remote-control signal operation |
| RS-232C | Control by a RS-232C communication |
| RS-485 | Control by a RS-485 communication |

Refer to Section 6.2 for details on changing the operation mode.

SECTION 6 OPERATION

(Note 2) Pump Operation Mode

| LCD Display | Pump Operation |
|-------------|--|
| NORMAL | Normal rotation |
| ACC. | Motor acceleration |
| BRAKE | Motor brake deceleration |
| STOP | Motor stop |
| IDLE | Free operation |
| E-STOP | Error occurs (stop) |
| E-BRAKE | Error occurs (motor deceleration) |
| E-IDLE | Error occurs (free operation = motor stop) |

(Note 3) Any character can be entered in the USER MEMO from the menu mode "SETTINGS/ USER MEMO INPUT". Use it for displaying the chambers connected to the pump etc.

(Note 4) The Motor Rotational Speed display can be selected from %, rpm and rps in the menu mode "SETTINGS/ ROT.SPEED/ DISPLAY".

An asterisk (*) is displayed after the speed display during variable speed operation.





(2) ALARM MODE

Alarm mode is a mode to display detected alarm contents and alarm history. If key **DISPLAY** is pushed in monitor mode, the LCD changes into alarm mode. The LCD changes automatically changes into alarm mode when an alarm is detected. See Table 7-6 "Table of Alarms" and Table 7-7 "Table of Warnings" about alarm code.

| Mode | Operation and LCD Display | Description of Display |
|-----------------------|---------------------------|--|
| ALARM LIST | | <p>The currently detected error is displayed. If there is more than one error, all the errors can be displayed using the [+] and [-] keys.</p> <p>ALARM No.1</p> <p>ALARM No.2</p> <p>ALARM No.3</p> |
| ALARM HISTORY | | <p>Maximum ALARM No.99</p> <p>HISTORY No.:</p> <p>Dates and times are recorded as Greenwich Mean Time (GMT).</p> |
| ALARM HISTORY DETAILS | | <p>The pump's operating status when an error is detected is displayed.</p> |

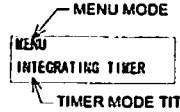
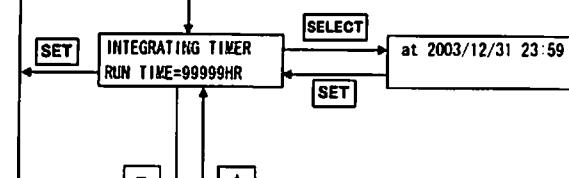
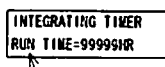
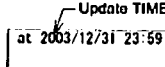
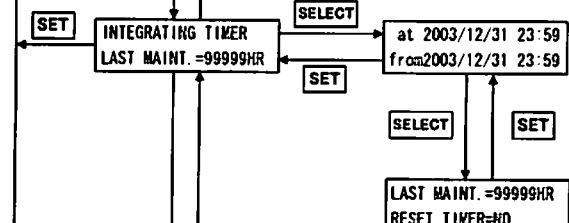
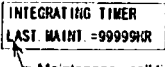
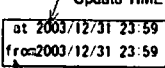
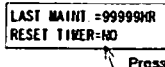
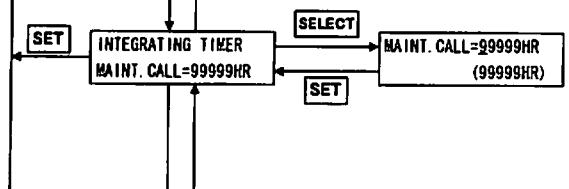
SECTION 6 OPERATION

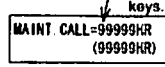
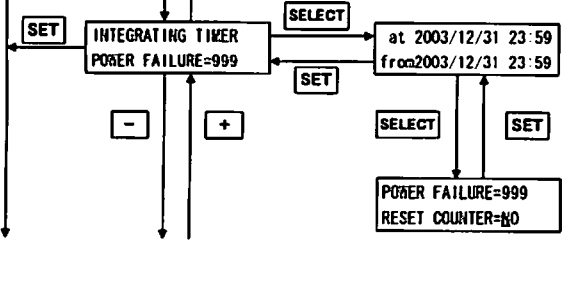
(3) MENU MODE/TIMER

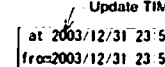
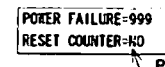
| Mode | Operation and LCD Display | Description of Display |
|-------------------|---|---|
| MENU |  |  <p>MENU MODE MENU INTEGRATING TIMER TIMER MODE TITLE</p> |
| INTEGRATING TIMER |  | <p>The pump's integrated run time is displayed.</p>  <p>INTEGRATING TIMER RUN TIME=99999HR RUN TIME</p>  <p>Update TIME at 2003/12/31 23:59</p> |
| INTEGRATING TIMER |  | <p>The pump's integrated run time is displayed. Reset is possible at the same time as, for example, maintenance.</p>  <p>INTEGRATING TIMER LAST MAINT.=99999HR Maintenance call time</p>  <p>Update TIME at 2003/12/31 23:59 from 2003/12/31 23:59 Reset TIME</p> <p>Select Reset Timer</p>  <p>LAST MAINT.=99999HR RESET TIMER=NO</p> <p>Press the <input type="checkbox"/> or <input type="checkbox"/> key to select between NO or YES</p> |
| INTEGRATING TIMER |  | <p>If the integrated value for the maintenance call time exceeds the set value, alarm code 99 (maintenance call warning) occurs. Setting the set value to 0 disables this function.</p>  <p>INTEGRATING TIMER MAINT. CALL=99999HR Settings of Maintenance call time</p> <p>The value is changed using the <input type="checkbox"/> and <input type="checkbox"/> keys.</p>  <p>MAINT. CALL=99999HR (99999HR)</p> |
| INTEGRATING TIMER |  | <p>A cursor moves to the right when pushes SELECT key.</p> <p>The number of power failure touch-downs is counted. If this number exceeds 250, alarm code 12 (number of power failure touch-downs alarm) occurs. Refer to Table 7-4 for the appropriate remedy.</p>  <p>INTEGRATING TIMER POWER FAILURE=999 Number of POWER FAILURE</p>  <p>Update TIME at 2003/12/31 23:59 from 2003/12/31 23:59 Reset TIME</p> <p>Select Reset Counter</p>  <p>POWER FAILURE=999 RESET COUNTER=NO</p> <p>Press the <input type="checkbox"/> or <input type="checkbox"/> key to select between NO or YES</p> |

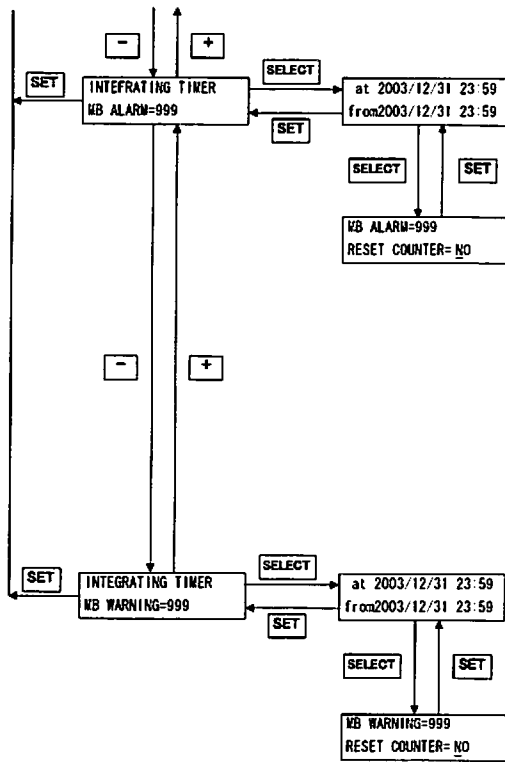

The number of alarms that occur for the magnetic bearing system at speeds exceeding 80% of the rated speed is counted. If this number exceeds 10, alarm code 11 (number of high-speed touch-downs alarm) occurs.

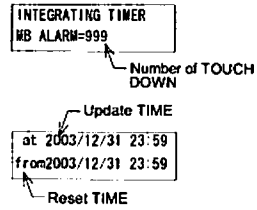

Select Reset Counter

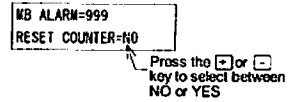

The number of warning that occur for the magnetic bearing system is counted.

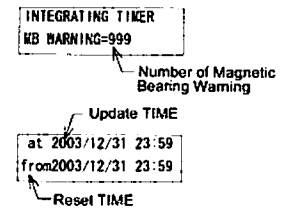

Select Reset Counter

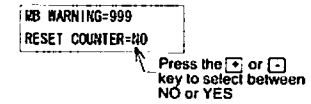

SECTION 6 OPERATION

(4) MENU MODE/SETTINGS

| Mode | Operation and LCD Display | Description of Display |
|----------------------------------|--|---|
| SETTINGS | | Select settings mode |
| USER MEMO SETTINGS | | Select user memo settings |
| RS-232C SETTINGS | | Select RS-232C settings |
| RS-485 SETTINGS | | Select RS-485 settings |
| ROTATIONAL SPEED SETTINGS | | Select rotational speed settings |
| REMOTE-CONTROL SIGNAL SETTINGS | | Select remote-control signal settings |
| WARNING OUTPUT SETTINGS (Note 1) | | Select warning output setting |
| DEFAULT SETTINGS | | Select default settings |
| USER MEMO SETTINGS | <p>Setting of any 20 characters is possible. (Ex. Connection name of Turbo Molecular Pump) Characters are displayed during monitor mode.</p> <p>Press the [+] or [-] key to select characters "A" to "Z", or "0" to "9".</p> <p>A cursor moves to the right when pushes [SELECT] key.</p> | Setting of any 20 characters is possible. (Ex. Connection name of Turbo Molecular Pump) Characters are displayed during monitor mode. |

(Note 1) The warning output setting function is installed in some custom-specification instruments; it is not available in all instruments. Modifications are required to install this function in an instrument that does not incorporate it. Consult your Shimadzu representative for details.

| Mode | Operation and LCD Display | Description of Display |
|-----------------------------|---------------------------|---|
| <p>RS-232C SETTINGS</p> | | <p>Baud rate setting</p> <p>Press the $\boxed{+}$ or $\boxed{-}$ key to select a baud rate between 19.2k, 9600, 4800, 2400, or 1200.</p> <p>BAUD RATE=9600bps (9600bps)</p> <p>Previous Setting</p> <p>Event Transmission Settings (Note 1)</p> <p>Press the $\boxed{+}$ or $\boxed{-}$ key to select between ON or OFF.</p> <p>EVENT SENDING=ON (ON)</p> <p>Previous Setting</p> <p>The event sending function is enabled or disabled. If set to ON, an event command is sent from the power supply unit when an event occurs.</p> |
| <p>RS-485 SETTINGS</p> | | <p>Baud rate setting</p> <p>Press the $\boxed{+}$ or $\boxed{-}$ key to select a baud rate between 19.2k, 9600, 4800, 2400, or 1200.</p> <p>BAUD RATE=9600bps (9600bps)</p> <p>Previous Setting</p> <p>Multi-drop setting (Note 1)</p> <p>Press the $\boxed{+}$ or $\boxed{-}$ key to select between ON or OFF.</p> <p>MULTIDROP=OFF (OFF)</p> <p>Previous Setting</p> <p>Set ON to select the multi-drop mode.</p> <p>Network ID setting (Note 1)</p> <p>Press the $\boxed{+}$ or $\boxed{-}$ key to select a value between 01 and 32.</p> <p>NETWORK ID=01 (01)</p> <p>Previous Setting</p> <p>Setting required in multi-drop mode.</p> <p>Event Transmission Settings (Note 1)</p> <p>Press the $\boxed{+}$ or $\boxed{-}$ key to select between ON or OFF.</p> <p>EVENT SENDING=ON (ON)</p> <p>Previous Setting</p> <p>The event sending function is enabled or disabled. If set to ON, an event command is sent from the power supply unit when an event occurs.</p> |

(Note 1) See APPENDIX-A "COMMUNICATIONS" for details.

SECTION 6 OPERATION

| Mode | Operation and LCD Display | Description of Display |
|----------------------------------|---|--|
| ROTATIONAL SPEED SETTINGS | <pre> graph TD S1[SETTINGS ROT. SPEED] -- SELECT --> S2[ROT. SPEED DISPLAY=%] S2 -- SET --> S1 S2 -- SELECT --> D[DISPLAY=% (%)] D -- SET --> S2 S2 -- +/- --> S3[ROT. SPEED SPEED=NORMAL] S3 -- SET --> S2 S3 -- SELECT --> S4[SPEED=NORMAL (NORMAL)] S4 -- SET --> S3 S3 -- +/- --> S5[ROT. SPEED LOW SP=100.0%] S5 -- SET --> S3 S5 -- SELECT --> S6[LOW SP=100.0% (100.0%)] S6 -- SET --> S5 </pre> | <p>Speed display setting</p> <p>Press the $\boxed{+}$ or $\boxed{-}$ key to select between %, rpm, or rps.</p> <p>DISPLAY=% (%)</p> <p>Previous Setting</p> <p>The format of the motor speed display in the pump monitor mode is changed.</p> <hr/> <p>Speed setting</p> <p>Press the $\boxed{+}$ or $\boxed{-}$ key to select between normal speed or low speed.</p> <p>SPEED=NORMAL (NORMAL)</p> <p>Previous Setting</p> <p>The pump rotates at the rated speed when NORMAL is selected. The pump rotates at the speed set with the low speed setting when LOW SPEED is selected. See Section 6.5 "Variable Speed Operation" for details.</p> <hr/> <p>Low speed setting</p> <p>Press the $\boxed{+}$ or $\boxed{-}$ key to select a value between 50 and 100.</p> <p>LOW SP=100.0% (100.0%)</p> <p>Previous Setting</p> <p>When the speed setting is set to LOW speed or the remote-control signal designates low speed, the pump continues operation at the speed set by the low speed setting.</p> |

| Mode | Operation and LCD Display | Description of Display |
|---|---------------------------|---|
| <p>REMOTE-CONTROL SIGNAL SETTINGS</p> | | <p>"ALARM" signal setting of remote-control signal (Note 2)</p> <p>Press the [+] or [-] key to select between E1-03 or SEMI E74.</p> <p>ALARM=E1-03 (E1-03) Previous Setting</p> <hr/> <p>"REMOTE" signal setting of remote-control signal (Note 2)</p> <p>Press the [+] or [-] key to select between E1-03 or SEMI E74.</p> <p>REMOTE=E1-03 (E1-03) Previous Setting</p> <hr/> <p>"STOP" signal setting of remote-control signal (Note 2)</p> <p>Press the [+] or [-] key to select between remote only or remote & RSXXX.</p> <p>STOP=REMOTE ONLY (REMOTE ONLY) Previous Setting</p> |
| <p>WARNING OUTPUT SETTINGS (Note 1)</p> | | <p>Press the [+] or [-] key to select between ON or OFF.</p> <p>WARNING DISPLAY=ON (ON) Previous Setting</p> <p>The setting changes the operation when warnings of alarm codes 86 to 94 (See Table 7-7 "Table of Warnings") occur, as follows:</p> <p>ON: Buzzer ON, ALARM LED flashes, Error event sent to RS-232C and RS-485, The remote-control connector "WARNING" signal turn ON</p> <p>OFF: Buzzer OFF, ALARM LED OFF No error event sent to RS-232C and RS-485, The remote-control connector "WARNING" signal turn OFF</p> |
| <p>DEFAULT SETTINGS</p> | | <p>DEFAULT SETTINGS RESET SETTINGS=NO</p> <p>Press the [+] or [-] key to select between NO or YES.</p> <p>Select YES and press the [SET] key to return all the above items to their default settings. (Note 3)</p> |

6

SECTION 6 OPERATION

(Note 1) The warning output setting function is installed in some custom-specification instruments; it is not available in all instruments. Modifications are required to install this function in an instrument that does not incorporate it. Consult your Shimadzu representative for details.

(Note 2) Remote-control signal settings mode

| Signals | | Description | Pin No. | |
|----------------|-----------------|--|-----------|-----------|
| ALARM | | | (20)–(22) | (21)–(22) |
| | EI-03 *1 | alarm occurrence | open | close |
| | | Power OFF and no failure | close | open |
| | SEMI E74 *2 | Power OFF and alarm occurrence | close | open |
| | | No failure | open | close |
| WARNING | | | (11)–(13) | (12)–(13) |
| | EI-03 *1 | warning occurrence | open | close |
| | | Power OFF and no failure | close | open |
| | SEMI E74 *2 | Power OFF and warning occurrence | close | open |
| | | No failure | open | close |
| REMOTE | EI-03 *1 | "REMOTE" signal is OFF in power failure regeneration braking even if remote-controlled operation is available. | | |
| | SEMI E74 *2 | "REMOTE" signal is always ON when remote-controlled operation is available. | | |
| STOP | REMOTE ONLY | "STOP" signal ((16)-(14) open) is effective for only the time when remote-controlled operation is available. | | |
| | REMOTE & RS-XXX | "STOP" signal ((16)-(14) open) is effective in operation by RS-232C or RS-485 set it in the cases that wants to use hardware inter lock. | | |

*1 When set to EI-03, behavior of remote-control signals is the same as SHIMADZU Turbo Molecular Pump power supply "EI-03MD" series.

*2 When set to SEMI E74, behavior of remote-control signals conform to SEMI E74 standard "Specification for vacuum Pump Interface-Turbomolecular Pumps"
Refer to the same standard about the shape of connectors and the pin configuration.

(Note 3) default parameters

| Function | default settings |
|------------------------|--|
| User memo | SHIMADZU EI-Dxx03M |
| RS-232C | BAUD RATE = 9600bps |
| RS-485 | BAUD RATE = 9600bps MULTI DROP = OFF NETWORK ID = 01 |
| Variable speed | DISPLAY = % SPEED = NORMAL LOW SP = 100% |
| Remote-control signal | ALARM = EI-03 REMOTE = EI-03 STOP = REMOTE ONLY |
| Warning output setting | WARNING DISPLAY = ON |

(5) MENU MODE/SELF TEST

| Mode | Operation and LCD Display | Description of Display |
|-----------|---|---|
| SELF TEST | <pre> graph TD A[MENU SELF TEST] -- SELECT --> B[SELF TEST SENSOR CHECK] B -- SET --> A B -- SELECT --> C[SENSOR CHECK CHECK SENSOR=NO] C -- SET --> B </pre> | <p>Select YES and press the SET key to execute self-diagnosis of the magnetic bearing sensor. If an abnormality is discovered by self-diagnosis, alarm codes 81 to 85 occur. Refer to Table 7-5 for the appropriate remedy. This function can be used only when the pump is stopped.</p> <p>SENSOR CHECK CHECK SENSOR=NO</p> <p>Press the + or - key to select between NO or YES.</p> |

6.7 Remote-Control Connector

6.7.1 Specifications

The controller is provided with remote-control connector for connection with remote operation, alarm signals, etc. Use this connector and a cable with shield as necessary. The shield of the cable should be connect to case of Remote-connector. (See Figs. 6-9, 6-10, 6-11 and Tables 6-2, 6-3) For remote-controlled operation, shift the REMOTE/LOCAL selection switch (Fig. 2-3 (15)) to REMOTE mode in advance. Fig. 6-9 Remote-Control Connector

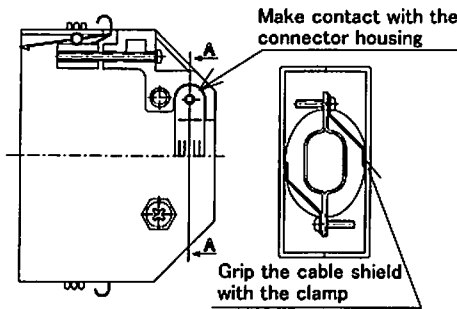

Fig. 6-8 Remote-Control Connector

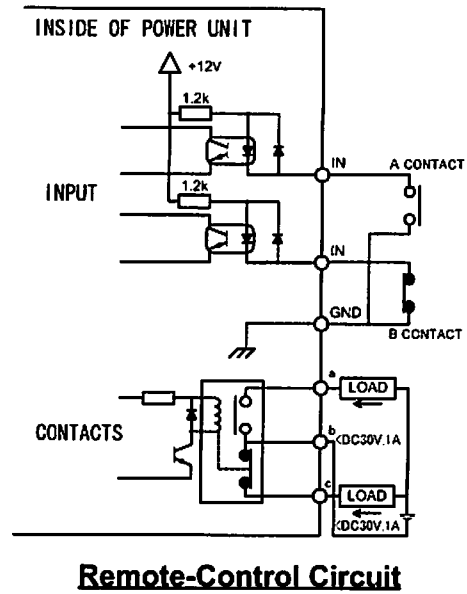

Table 6-2 Start/Stop According to Remote-Control Signals

| Connection method | By momentary type START/STOP switch | By alternate type switch |
|-------------------|--|--|
| Wiring connection | | |
| Starting | Pump start by short-circuiting (15) and (14). Pump stop by opening (16) and (14). | Pump start, with the contact close or photo transistor ON ((16) to (14) short-circuit) Pump stop, with the contact open or photo transistor OFF ((16) to (14) open) |
| Electric capacity | [Contact] : It is connected to +12V circuit and subject to stable open-close of DC 5 V, 1mA. Voltage...30VDC or more, Current...10mA or more [Photo transistor] : Select a photo transistor with a collector-emitter voltage limit of 30VDC and an on-state collector current of 10mA or more. | |
| Input rating | Direct forward current 50mA; DC reverse voltage 5V | |

Table 6-3 Remote-Control Signals (Default Settings)

| Classification | Signals | Pin No. | Operation | Electric spec. |
|----------------|---------------------|------------------------|---|---|
| Inputs | START | (15) | Starting operation on GND and short-circuiting (Note 1) | Contact input |
| | STOP | (16) | Stopping operation on GND and circuit opening (Note 1) (Note 2) | |
| | RESET | (17) | Resetting operation on GND an short-circuiting | |
| | LOW SPEED | (33) | Variable Speed Operation on GND and short-circuiting | |
| | GND | (14) | | |
| Outputs | ROTATION | (29), (4), (30) | During rotation; (29) - (30) : open → close (make contact) (4) - (30) : close → open (break contact) | Contact output Contact capacity (resistance load) 30 VDC 1 A |
| | NORMAL | (25), (2), (26) | During normal rotation; (25) - (26) : open → close (make contact) (2) - (26) : close → open (break contact) | |
| | ACCELERATION | (23), (1), (24) | During acceleration; (23) - (24) : open → close (make contact) (1) - (24) : close → open (break contact) | |
| | BRAKE | (27), (3), (28) | During deceleration; (27) - (28) : open → close (make contact) (3) - (28) : close → open (break contact) | |
| | REMOTE | (31), (5), (32) | Remote-controlled operation is available; (31) - (32) : open → close (make contact) (5) - (32) : close → open (break contact) (Note 2) | |
| | ALARM (Note 4) | (21), (20), (22) | Against alarm; (21) - (22) : open → close (make contact) (20) - (22) : close → open (break contact) (Note 2) | |
| | WARNING (Note 4) | (12) (11) (13) | Against warning; (12) - (13) : open → close (make contact) (11) - (13) : close → open (break contact) (Note 2) | |

(Note 1) "STOP" signal is prior to "START" signal.

(Note 2) It is possible to change movement by remote-control signal settings of settings mode.
(See Section 6.6 "Software Operation" (4).)

(Note 3) Don't connect any pins other than specified above.

(Note 4) See Table 7-6 "Table of Alarms" and Table 7-6 "Table of Alarms" about alarm and warning.

(Note 5) One Reset signal is input each time the contacts close. Repeatedly short and open the contacts to input multiple Reset signals. See section 7.5.3 for details about the error-reset procedure.

(Note 6) Approximately 6 seconds is required for the remote control signal to turn ON after the POWER switch is turned ON.

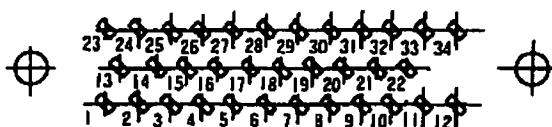

Fig. 6-9 Arrangement of Remote-Control Connector Pins

(The power supply unit rear panel attachment connectors, as viewed from the front)

6.7.2 Compatibility with Previous Models

6.7.2.1 Replacing the EI-xx03M/MD Power Supply Unit

CAUTION

The transistor output has been discontinued. The pins that were used for that output are now assigned to different functions. If wires were connected to these pins with previous models, then simply making the connection as it is could result in a malfunction on the system controller end. Therefore, please revise the wiring.

To avoid the risk of fire, please remove wiring, if wiring of power supply for the transistor output is connected to Pin No.1 and 2 of remote-control connector.

Replacing EI-xx03M/MD Power Supply Units As-Is (EI-03 Compatible Mode)

(1) Connectors

The shape and pin count of connectors are mutually compatible and can be utilized as-is.

(2) Pin Configuration

It is compatible with EI-xx03M/MD units, except for the transistor output. (See Table 6-4)

(3) Signal Activity

It is compatible with EI-xx03M/MD units.

When using it, changing into SEMI E74 Standard Mode

Change the "ALARM" signal and "REMOTE" signal activation settings from EI-03 to SEMI E74, in accordance with the "Remote-Control Signal Settings" instructions included in the (4) Menu Mode table of Section 6.6 "Software Operation".

(1) Connectors

The shape and pin count of connectors are mutually compatible and can be utilized as-is.

(2) Pin Configuration

The "ALARM" signal pin assignments ("make contact" or "break contact") are the reverse of EI-xx03M/MD units. If necessary, change the wiring connections.

(3) Signal Activity

The "ALARM" signal and "REMOTE" signal activity differs from EI-xx03M/MD units.

| Power Supply Unit | ALARM Signal | REMOTE Signal |
|-----------------------------------|---|--|
| EI-xx03M/MD | When the power supply is turned off, the ALARM signal is off. | Remote signal is forcibly off during regenerative braking. |
| EI-Dxx03M SEMI E74 Settings | When the power supply is turned off, the ALARM signal is on. | Remote signal during regenerative braking depends on the control mode. |

Table 6-4 Pin Configuration Comparison Chart (Default Settings)

| Signal Type | Signals | Pin numbers | | Compatibility |
|--------------------------------|--------------------|--------------------|-------------------------------------|---|
| | | EI-xx03M/MD | EI-Dxx03M (EI-03Compatible Mode) | |
| INPUT | START | 15 | 15 | Same pin number, same function |
| | STOP | 16 | 16 | |
| | RESET | 17 | 17 | |
| | LOW SPEED | | 33 | Variable rpm input added |
| | GND(COMMON) | 14 | 14 | Same pin number, same function |
| OUTPUT1 (Relay Output) | ROTATION | 29 : Make contact | 29 : Make contact | Same pin number, same function |
| | | 30 : Common | 30 : Common | |
| | | | 4 : Break contact | |
| | NORMAL | 25 : Make contact | 25 : Make contact | Same pin number, same function |
| | | 26 : Common | 26 : Common | |
| | | | 2 : Break contact | |
| | ACCELERATION | 23 : Make contact | 23 : Make contact | Same pin number, same function |
| | | 24 : Common | 24 : Common | |
| | | | 1 : Break contact | |
| | BRAKE | 27 : Make contact | 27 : Make contact | Same pin number, same function |
| | | 28 : Common | 28 : Common | |
| | | | 3 : Break contact | |
| | ALARM | 21 : Make contact | 21 : Make contact | Same pin number, same function |
| | | 22 : Common | 22 : Common | |
| | | 20 : Break contact | 20 : Break contact | |
| WARNING | | 11 : Break contact | Added function | |
| | | 13 : Common | | |
| | | 12 : Make contact | | |
| REMOTE | 31 : Make contact | 31 : Make contact | Same pin number, same function | |
| | 32 : Common | 32 : Common | | |
| | | 5 : Break contact | | "Break contact" added |
| OUTPUT2 (Transistor Output) | MOTOR | 3 | | Removed function |
| | MAG.BEARING | 4 | | EI-Dxx03M units have a pin assigned to the "Break contact" output terminal of OUTPUT1 |
| | POWER FAILURE | 5 | | |
| | PUMP TEMP. | 7 | | (If wiring is connected to the pin for EI-xx03M/MD units and is used without modification, a malfunction could occur on the system controller side, so please remove it.) |
| | CONT. TEMP. | 8 | | |
| | V(+) (Note 1) | 1 | | |
| | COM(-) (Note 1) | 2 | | |

(Note 1) To avoid the risk of fire, please remove wiring, if wiring of power supply for the transistor output is connected to the pin.

6.7.2.2 Replacing EI-xx03MZ Power Supply Units

If using the remote control signal for previous EI-xx03MZ power supply units (where "xx" is a number that indicates the applicable pump type), then the following checks and changes to settings are necessary when replacing the unit with an EI-Dxx03M model.

Change the "ALARM" signal and "REMOTE" signal activation settings from EI-03 to SEMI E74, in accordance with the "Remote-Control Signal Settings" instructions included in the (4) Menu Mode table of Section 6.6 "Software Operation".

(1) Connectors

The shape and pin count are both different. (See Figure 6-12)

(2) Pin Configuration

Different. (See Table 6-5)

(3) Signal Activity

Once the settings have been changed, it is compatible with SEMI 74 Standard Mode.

o

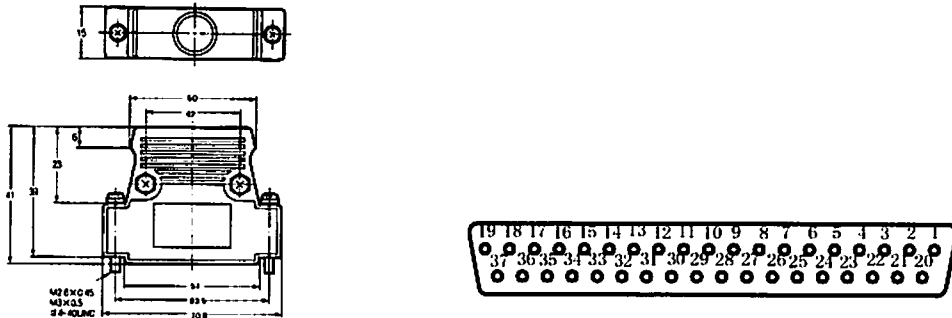

Remote-Control Connector

Arrangement of Remote-Control Connector Pins

(The power supply unit rear panel attachment connectors, as viewed from the front)

Fig. 6-10 Previous EI-xx03MZ Model Remote Control Connector and Pin Configuration

**Table 6-5 EI-xx03MZ vs. EI-Dxx03M Pin Configuration Comparison Chart
-After Changing Settings (SEMI E74 Standard Mode)**

| Signal type | Signals | Pin numbers | | Compatibility |
|-----------------------------|--------------|--------------------|--|---------------|
| | | EI-xx03MZ | EI-Dxx03M SEMI E74 Standard Mode | |
| INPUT | START | 2 | 15 | Same function |
| | STOP | 3 | 16 | |
| | RESET | 4 | 17 | |
| | LOW SPEED | 6 | 33 | |
| | GND(COMMON) | 1 | 14 | |
| OUTPUT (Relay Output) | ROTATION | 17 : Make contact | 29 : Make contact | |
| | | 19 : Common | 30 : Common | |
| | | 18 : Break contact | 4 : Break contact | |
| | NORMAL | 11 : Make contact | 25 : Make contact | |
| | | 13 : Common | 26 : Common | |
| | | 12 : Break contact | 2 : Break contact | |
| | ACCELERATION | 8 : Make contact | 23 : Make contact | |
| | | 10 : Common | 24 : Common | |
| | | 9 : Break contact | 1 : Break contact | |
| | BRAKE | 14 : Make contact | 27 : Make contact | |
| | | 16 : Common | 28 : Common | |
| | | 15 : Break contact | 3 : Break contact | |
| | ALARM | 27 : Make contact | 20 : Make contact | |
| | | 28 : Common | 22 : Common | |
| | | 26 : Break contact | 21 : Break contact | |
| | WARNING | 30 : Make contact | 11 : Make contact | |
| | | 31 : Common | 13 : Common | |
| | | 29 : Break contact | 12 : Break contact | |
| | REMOTE | 20 : Make contact | 31 : Make contact | |
| | | 22 : Common | 32 : Common | |
| 21 : Break contact | | 5 : Break contact | | |

6

**Table 6-5 EI-xx03MZ vs. EI-Dxx03M Pin Configuration Comparison Chart
-After Changing Settings (SEMI E74 Standard Mode)**

| Signal type | Signals | Pin numbers | | Compatibility |
|-------------|---------|-------------|--|---------------|
| | | EI-xx03MZ | EI-Dxx03M SEMI E74 Standard Mode | |

This page is intentionally left blank.

TROUBLESHOOTING

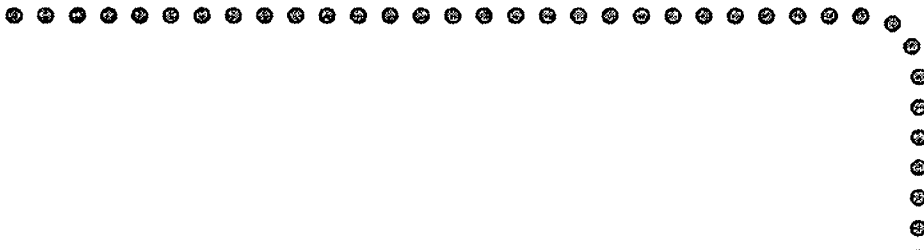

- 7.1 Nothing Happens After an Operation is Made
- 7.2 Power Failures
- 7.3 Vacuum Pressure Rise
- 7.4 Abnormal Noise and/or Vibration
- 7.5 Alarm Detection Capabilities

7.1 Nothing Happens After an Operation is Made

Table 7-1 Nothing Happens After an Operation is Made

| | PROBLEM | POSSIBLE CAUSES | CORRECTIVE ACTION |
|---|---|---|--|
| 1 | Power ON/OFF switch in the ON position but the turbo molecular pump fails to operate. | Electrical power cable not properly connected. | Properly connect the electrical power cable. |
| | | Electrical power outside power supply unit's power range. | Operate within power supply unit's power range. |
| | | Blown fuse (F1, F2) | Replace blown fuse. |
| | | POWER switch fails to the off position. | Replace POWER switch. Consult the nearest Shimadzu service company. |
| 2 | START switch pressed but turbo molecular pump does not accelerate. | REMOTE/LOCAL selection switch in the REMOTE position. | Set the REMOTE/LOCAL selection switch in the LOCAL position. |
| | | Other causes. | Check the power supply unit's ALARM lamp is not ON. If an alarm is indicated, correct the malfunction and reset the power supply unit. |
| 3 | Remote "START" signal active but the turbo molecular pump does not accelerate. | REMOTE/LOCAL selection switch in LOCAL position. | Set the selection switch in the REMOTE position. |
| | | "STOP" signal active. | Deactivate "STOP" signal. |
| | | Other problems. | Check the unit's ALARM lamp is not ON. If an alarm is indicated, correct the malfunction and reset the power supply unit. |
| 4 | STOP switch pressed but the turbo molecular pump does not decelerate. | REMOTE/LOCAL selection switch is in the REMOTE position. | Set the selection switch in the LOCAL position. |
| 5 | Remote "STOP" signal activated but the turbo molecular pump does not decelerate. | REMOTE/LOCAL selection switch is in the LOCAL position. | Set the selection switch in the REMOTE position. |

7.3 Vacuum Pressure Rise

A rapid rise of vacuum pressure in the turbo molecular pump causes the internal motor of the turbo molecular pump to start braking and the ALARM lamp (Fig. 2-3 (14)) lights.

7.4 Abnormal Noise and/or Vibration

Should the turbo molecular pump ever generate abnormal noise and/or vibration, the turbo molecular pump operation is to be stopped immediately.

But there is possible that a race of touch-down bearing (Fig. 3-1 (9)) may make sounds for seconds when the pump internal pressure gets back to atmospheric pressure using air (or non-activity gas). This phenomena is not abnormal and make no damage to the pump, because the air whirlpool sometimes occurs and then makes the touch-down bearing rotate slightly.

CAUTION

When turning the POWER switch for the power supply unit on or off, a "clunk" sound may be heard from inside the pump. This sound is from the rotor inside the pump being levitated or de-levitated. This is normal.

7.5 Alarm Detection Capabilities

The fault detection functions shown in Table 7-6 "Table of Alarms" and Table 7-7 "Table of Warnings" are incorporated for protection in the event of a problem with the turbo molecular pump or power supply unit.

When an error is detected, check the ALARM lamp (Fig. 2-3 (14)) and the alarm mode display on the front panel (See Section 6.6 "Software Operation" (2)) and refer to Tables 7-4 and 7-5 for the appropriate remedy.

7.5.1 Movement in Alarm Detection Capabilities (ALARM)

1. ALARM lamp (Fig. 2-1 (14)) lights.
2. Alarm description is displayed on LCD.
3. The remote-control connector "ALARM" signal turn ON.
4. The buzzer sounds.

SECTION 7 TROUBLESHOOTING

5. The pump start the protective operations shown in Table 7-6 "Table of Alarms."
6. The detection error is recorded in the error log.

7.5.2 Movement in Alarm Detection Capabilities (WARNING)

The warning output setting in the menu mode "SETTINGS / WARNING DISPLAY" item on the LCD changes the operation when a warning occurs.

<When the warning output setting is ON>

1. ALARM lamp (Fig. 2-1 (14)) flashes.
2. Warning description is displayed on LCD.
3. The remote-control connector "WARNING" signal turn ON.
4. The buzzer sounds.
5. Pump operation continues.
6. The detection error is recorded in the error log.

<When the warning output setting is OFF>

[When warnings of alarm codes 86 to 94 do not occur.] (See Table 7-7 "Table of Warnings")

The operation is the same as the warning output setting is ON.

[When warnings of alarm codes 86 to 94 occur.] (See Table 7-7 "Table of Warnings")

- (1. ALARM lamp (Fig. 2-1 (14)) does not flash.)
2. Warning description is displayed on LCD.
- (3. The remote-control connector "WARNING" signal do not turn ON.)
- (4. The buzzer does not sound.)
5. Pump operation continues.
6. The detection error is recorded in the error log.

7.5.3 Reset Procedure

1. The buzzer stops after the first reset operation.
2. Refer to the Troubleshooting information and eliminate the cause of the problem.
3. Conduct the reset operation again.
4. (ALARM) If the problem has been eliminated, the ALARM lamp (Fig. 2-1 (14)) goes out, the "ALARM" remote-control signals (see Table 6-3) turn OFF after an alarm was given, the pump rotor decelerates rotational speed.
(WARNING) When the problem is eliminated after a warning occurred, pump operation continues.
5. If the problem was not completely eliminated, the buzzer sounds again and the error is detected.

※ When the buzzer does not sound and if the warning output setting is OFF in the menu mode SETTINGS/WARNING DISPLAY item on the LCD, the first reset operation after a warning occurs is equivalent to the third reset operation.

Table 7-4 If the ALARM Lamp Lights

| | LCD Display | Possible Cause | Remedy | Section |
|---|--|---|--|---------|
| 1 | 11=TD COUNTER LIMIT 12=PF COUNTER LIMIT | The number of high speed or power failure touch-downs has exceeded the prescribed number. | The touch-down bearing may have deteriorated. Consult Shimadzu or an approved service company regarding replacement of the touch-down bearing. | |
| 2 | 13=WRONG TMP MODEL | The models of pump and power supply do not match. | Check the combination of the pump and power supply models. Check the connection of the magnetic bearing cable. Also check that the connector pins are not bent. Turn off the power supply before checking the magnetic bearing cable. Never disconnect the cable while the power is on. | 5.3 |
| 3 | 14=AC LOW VOLTAGE 15=POWER FAILURE | Power failure or reduction in the power supply voltage. | Wait for the power to be restored. An unfamiliar sound will be heard a few minutes after a power failure. This sound occurs when the rotor contacts the protective bearing as magnetic levitation cannot be maintained. This is not an abnormal sound. | |
| | | POWER switch was turned off by mistake. | Wait about 5 seconds before turning the POWER switch back on. Re-acceleration is possible after resetting and start-up. | |
| 4 | 16=TMP:OVERLOAD | Drop in rotation speed during rotation at rated speed (increased internal pump pressure). | Check that the outlet and inlet pressures are below the specified maximum pressures. Check for leakage. Check that too much purge gas is not flowing. Check that process gas flow rate is not too high. | |

SECTION 7 TROUBLESHOOTING

| | LCD Display | Possible Cause | Remedy | Section |
|----|--|--|---|-------------------|
| 5 | 21=TMP TEMP/MB CABLE | High pump unit temperature. | Check that the ambient temperature around the pump is within the specified range. For the air-cooled models, check that the cooling fan is operating and cooling is not hindered by peripheral objects. For water-cooled models, check that the temperature and flow rate of the cooling water are within the specified ranges. Check that no load in excess of the specified range is continuously applied to the pump. | |
| | | Magnetic bearing cable is not connected correctly. | Check the connection of the magnetic bearing cable. Also check that the connector pins are not bent. Turn off the power supply before checking the magnetic bearing cable. Never disconnect the cable while the power is on. | 5.3 |
| 6 | 22=TMP:SENSOR ERROR 46=MOTOR OVERSPEED 47=EI:R-SPEED ERROR | Rotation detection signal from the motor cannot be detected correctly. | Check that equipment causing noise is not used around the power supply unit, pump unit, motor cable, or magnetic bearing cable. | 5.1 5.2 5.3 |
| 7 | 23=EI:MOTOR OVERCURRE 34=EI:INV. OVERCURRE | Overcurrent supplied to the motor. | Check the motor cable and magnetic bearing cable. (Check for connection and wiring likely to cause disconnection or short circuit.) | |
| 8 | 31=EI:BR OVERTEMP 32=EI:DC-DC OVERTEMP | Temperature increase in the power supply unit. | Check that the ambient temperature around the power supply unit is within the specified range. Check the ventilation of the power supply unit. | 4.1 |
| | | | | 5.1 |
| 9 | 33=EI:FAN ERROR | Fan stopped. | Check that the fan on the power supply unit rear panel is operating. Remove any object obstructing its operation. | 5.1 |
| 10 | 35=EI:INV. OVERVOLT 36=EI:DC-DC LOW VOLT 37=EI:DC-DC OVERCURRE 38=EI:DC-DC OVERVOLT 45=EI:BRAKE OVERTIME | Defective circuit in the power supply unit. | Turn the power on again after the pump stops. The power supply unit must be repaired if the problem occurs again. | |
| 11 | 43=EI:PARAM ERROR | Defective circuit in the power supply unit. | Turn the power on again after the pump stops. The power supply unit must be repaired if the problem occurs again. | |

7.5 Alarm Detection Capabilities

| | LCD Display | Possible Cause | Remedy | Section |
|----|--|---|--|--------------------------|
| 12 | 44=EI:CPU ERROR 66=MB:DSP ERROR 67=MB:DSP OVERFLOW | Abnormal operation of circuit in the power supply unit. | Check that the ambient temperature around the power supply unit is within the specified range. Check that equipment causing noise is not used around the power supply unit, pump unit, motor cable, or magnetic bearing cable. | 4.1 5.1 5.2 5.3 |
| 13 | 48=EI:ACCEL OVERTIME | Rotation speed does not increase at start-up. | Check that the outlet and inlet pressures are not too high. Check for leakage. Check that too much purge gas is not flowing. | 6.2 |
| 14 | 49=TMP:CAN NOT START | Pump does not rotate. | Adhesion of reaction products or damage to the protective bearing is the possible cause. Remove the pump from the unit and check that the rotor blades rotate smoothly at the inlet. An overhaul is required if blades do not rotate smoothly. | |
| 15 | 51=MB:VIBRATION2 X1 52=MB:VIBRATION2 Y1 53=MB:VIBRATION2 X2 54=MB:VIBRATION2 Y2 55=MB:VIBRATION2 Z 56=MB:VIBRATION1 X1 57=MB:VIBRATION1 Y1 58=MB:VIBRATION1 X2 59=MB:VIBRATION1 Y2 60=MB:VIBRATION1 Z | Strong external shock or vibrations. | If the shock or vibrations are transient, re-acceleration is possible. If the shock or vibrations occur frequently, stop the pump and remove the source of the shock or vibrations; or re-examine the pump mounting method. | |
| 16 | 61=MB:SENSOR ERR. X1 62=MB:SENSOR ERR. Y1 63=MB:SENSOR ERR. X2 64=MB:SENSOR ERR. Y2 65=MB:SENSOR ERR. Z | Magnetic bearing cable is not connected correctly. | Check the connection of the magnetic bearing cable. Also check that the connector pins are not bent. Turn off the power supply before checking the magnetic bearing cable. Never disconnect the cable while the power is on. | 5.3 |
| | | The rotor does not move due to adhering matter or a damaged touch-down bearing. | Remove the pump and check that the rotor rotates smoothly. The pump requires an overhaul if the rotor does not rotate or the resistance to rotation is large. | |
| 17 | 68=MB:BALANCE AXIS1 69=MB:BALANCE AXIS2 | Rotor inside the pump is out of balance. | Adhesion of reaction products is a possibility. An overhaul is required. | |

Table 7-5 If the ALARM Lamp Flashes

| | LCD Display | Possible Cause | Remedy | Section |
|---|--|--|---|---------|
| 1 | 81=MB:SELFCHECK X1 82=MB:SELFCHECK Y1 83=MB:SELFCHECK X2 84=MB:SELFCHECK Y2 85=MB:SELFCHECK Z | Rattling of the protective bearing becomes pronounced. | Deterioration of the protective bearing is likely. Overhaul as soon as possible to avoid damage to the protective bearing in the event of a power failure etc. | |
| 2 | 86=MB:VIB. WARN. X1 87=MB:VIB. WARN. Y1 88=MB:VIB. WARN. X2 89=MB:VIB. WARN. Y2 90=MB:VIB. WARN. Z | Transient strong external shock or vibrations. | Continuous operation is possible. However, if the shock or vibrations occur frequently, stop the pump and remove the source of the shock or vibrations; or re-examine the pump mounting method. | |
| 3 | 91=MB:BALANCE WARN.1 92=MB:BALANCE WARN.2 | Rotor inside the pump is out of balance. | Adhesion of reaction products is a possibility. An overhaul is recommended. | |
| 4 | 93=MB:AIR RASH A 94=MB:AIR RASH B | Atmospheric penetration has occurred. | Create a vacuum system not allowing atmospheric penetration by re-examining the operating sequence of the back pump and valves etc. | |
| 5 | 99=MAINTENANCE TIME | Maintenance call timer has reached the set time. | Implement maintenance works prescribed by the customer, such an overhaul. The alarm can be cancelled by resetting the maintenance call timer after implementing necessary works. | 6.6 |

※ When warnings of alarm codes 86 to 94 (See Table 7-7 "Table of Warnings") occur, the alarm lamp does not flash and the display appears on the LCD only if the warning output setting is OFF in the menu mode SETTINGS/WARNING DISPLAY item on the LCD.

Table 7-6 Table of Alarms

| Alarm Code | LCD Display | Cause | Protective Action |
|------------|-----------------------|---|--|
| 11 | 11=TD COUNTER LIMIT | Counts of the high speed touch-down counter exceeded the specified number. | Start-up impossible (detected during power supply self-diagnostics) |
| 12 | 12=PF COUNTER LIMIT | Counts of the power failure touch-down counter exceeded the specified number. | |
| 13 | 13=WRONG TMP MODEL | The combination of the pump and power supply is wrong. | |
| 14 | 14=AC LOW VOLTAGE | Fall in AC input power voltage. | Regenerative braking |
| 15 | 15=POWER FAILURE | Power failure. | |
| 16 | 16=TMP:OVERLOAD | After accelerating to 80% of the designated speed or low-speed setting, the speed dropped below 80% due to overloading etc. | Deceleration |
| 21 | 21=TMP TEMP/MB CABLE | Increased pump drive motor temperature. MB cable is not connected. | Free run (motor stop) |
| 22 | 22=TMP:SENSOR ERROR | Pump rotation signal could not be detected correctly. | |
| 23 | 23=EI:MOTOR OVERCURRE | Overcurrent ran through the motor. | |
| 24 | 24=TMP PUMP TEMP | Pump Temperature | |
| 31 | 31=EI:BR OVERTEMP | Increased temperature inside power supply unit. | |
| 32 | 32=EI:DC-DC OVERTEMP | Increased temperature inside power supply unit. | |
| 33 | 33=EI:FAN ERROR | Power supply cooling fan has stopped. | |
| 34 | 34=EI:INV. OVERCURRE | Overcurrent ran through the motor. | |
| 35 | 35=EI:INV. OVERVOLT | Defective circuit in the power supply. | |
| 36 | 36=EI:DC-DC LOW VOLT | Defective circuit in the power supply. | |
| 37 | 37=EI:DC-DC OVERCURRE | Defective circuit in the power supply. | Deceleration |
| 38 | 38=EI:DC-DC OVERVOLT | Defective circuit in the power supply. | |
| 43 | 43=EI:PARAM ERROR | Stored parameters are not correct. | Start-up impossible (detected during power supply self-diagnostics) |
| 44 | 44=EI:CPU ERROR | Error in the CPU for inverter control. | Free run (motor stop) |
| 45 | 45=EI:BRAKE OVERTIME | Pump does not stop within the specified time after the stop operation. | |
| 46 | 46=MOTOR OVERSPEED | Pump rotation speed is too high. | |
| 47 | 47=EI:R-SPEED ERROR | Pump rotation speed cannot be detected. | |

SECTION 7 TROUBLESHOOTING

| Alarm Code | LCD Display | Cause | Protective Action |
|------------|----------------------|--|-------------------|
| 48 | 48=EI:ACCEL OVERTIME | Pump does not accelerate to 80% of the designated speed or low-speed setting within the specified time after start-up. | Deceleration |
| 49 | 49=TMP:CAN NOT START | Pump fails to rotate within 15 seconds after start-up. | |
| 51 | 51=MB:VIBRATION2 X1 | Continuous excessive vibration of the magnetic bearing. | |
| 52 | 52=MB:VIBRATION2 Y1 | | |
| 53 | 53=MB:VIBRATION2 X2 | | |
| 54 | 54=MB:VIBRATION2 Y2 | | |
| 55 | 55=MB:VIBRATION2 Z | | |
| 56 | 56=MB:VIBRATION1 X1 | Excessive magnetic bearing vibration. | |
| 57 | 57=MB:VIBRATION1 Y1 | | |
| 58 | 58=MB:VIBRATION1 X2 | | |
| 59 | 59=MB:VIBRATION1 Y2 | | |
| 60 | 60=MB:VIBRATION1 Z | | |
| 61 | 61=MB:SENSOR ERR. X1 | Abnormal output signal from the magnetic bearing sensor. | |
| 62 | 62=MB:SENSOR ERR. Y1 | | |
| 63 | 63=MB:SENSOR ERR. X2 | | |
| 64 | 64=MB:SENSOR ERR. Y2 | | |
| 65 | 65=MB:SENSOR ERR. Z | | |
| 66 | 66=MB:DSP ERROR | Error in the DSP for magnetic bearing control. | |
| 67 | 67=MB:DSP OVERFLOW | Overflow in the magnetic bearing control calculations. | |
| 68 | 68=MB:BALANCE AXIS1 | Rotor is out of balance. | |
| 69 | 69=MB:BALANCE AXIS2 | | |

Table 7-7 Table of Warnings

| Alarm Code | LCD Display | Causes | Protective Action |
|------------|------------------------|---|--|
| 81 | 81=MB:SELFCHECK X1 | Results of magnetic bearing sensor self-diagnostics are abnormal. | Operation is possible (detected during power supply self-diagnostics). |
| 82 | 82=MB:SELFCHECK Y1 | | |
| 83 | 83=MB:SELFCHECK X2 | | |
| 84 | 84=MB:SELFCHECK Y2 | | |
| 85 | 85=MB:SELFCHECK Z | | |
| 86 | 86=MB:VIB. WARN. X1 | Vibrations of the magnetic bearing become temporarily excessive. | Operation continued. |
| 87 | 87=MB:VIB. WARN. Y1 | | |
| 88 | 88=MB:VIB. WARN. X2 | | |
| 89 | 89=MB:VIB. WARN. Y2 | | |
| 90 | 90=MB:VIB. WARN. Z | | |
| 91 | 91=MB:BAL. WARN. AXIS1 | Rotor is slightly out of balance. | |
| 92 | 92=MB:BAL. WARN. AXIS2 | | |
| 94 | 94=MB:AIR RASH B | Atmospheric penetration. | |
| 99 | 99=MAINTENANCE TIME | Maintenance call timer reaches its set time. | |

This page is intentionally left blank.

Appendix A

COMMUNICATIONS

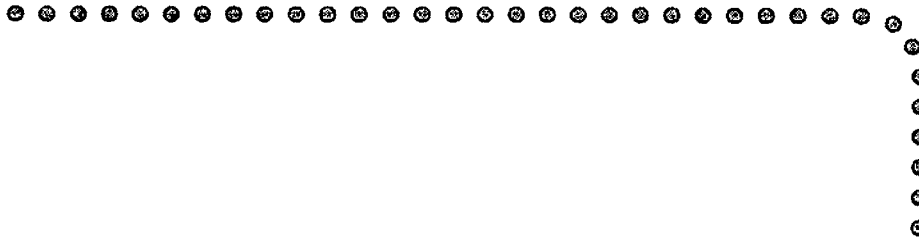

- A1. GENERAL SPECIFICATION
- A2. INTERFACE SPECIFICATION
 - A2.1 RS-232C
 - A2.2 RS-485
- A3. POWER SUPPLY TO COMPUTER CONNECTION
 - A3.1 Communication Cable Connection
 - A3.2 Serial Communications Baud Rate Configuration
 - A3.3 RS-485 Multi-drop Settings
- A4. SERIAL COMMUNICATIONS PROTOCOL
- A5. TABLE OF COMMANDS
- A6. COMMAND DESCRIPTION
 - A6.1 Operation Mode
 - A6.2 Operation
 - A6.3 Run Status
 - A6.4 Parameters
 - A6.5 Events
 - A6.6 Timer
 - A6.7 History
 - A6.8 Settings
 - A6.9 Shared Answer
- A7. RS-232C COMMANDS / ANSWERS
- A8. RELATION OF LOCAL MODE TO REMOTE MODE OPERATIONS
- A9. TROUBLESHOOTING
 - A9.1 No Message can Transmit and Receive
 - A9.2 Sending and Receiving are Done, But Receivable Messages are Invalid
 - A9.3 Characters Get Disordered from Time to Time, Then Resulting in CHECKSUM Error

A1. GENERAL SPECIFICATION

The EI-D03M series power supply units contain serial interfaces conforming to RS-232C and RS-485 specifications. The following functions are available by connecting a computer with communication capacity to these interfaces and creating the appropriate software.

The RS-232C and RS-485 interfaces can be used simultaneously, permitting simultaneous access from two computers. Also, the RS-485 interface permits multi-drop connections, allowing multiple power supplies to be connected to a single computer.

1. **Checking current operation mode:** The serial interfaces allow the user to check the mode selection switch status (REMOTE/LOCAL). In REMOTE mode, the user can change the operation mode to RS-232C or RS-485.
2. **Operation:** Operations equivalent to the START, STOP, and RESET switches are available in the RS-232C or RS-485 operation mode. Also, the speed setting can be made using the set value write function.
3. **Checking turbo molecular pump run status:** The serial interfaces allow the user to check the current turbo molecular pump's running status (Normal rotation, Accelerating, Decelerating, failure occurrence, etc.).
4. **Reading parameters:** The serial interfaces allow the user to read a variety of turbo molecular pump parameters such as pump rotational speed and motor current which are stored in the power supply unit.
5. **Receiving events:** The power supply unit can transmit status commands for events such as failure occurrences, rotation start and stop, and attainment of normal rotation speed.
6. **Reading history data:** The serial interfaces allow the user to read the alarm history data displayed in the LCD display history mode.
7. **Reading and writing timer data:** The serial interfaces allow the user to read the timer and counter values displayed in the LCD display timer mode and to reset the counters.
8. **Reading and writing settings data:** The serial interfaces allow the user to read and change settings in the LCD display setting mode.

A2. INTERFACE SPECIFICATION

A2.1 RS-232C

A2.1.1 Transmission Specification

| | |
|-------------------------|--|
| Interface | RS-232C |
| Synchronous system | Asynchronous |
| Transmission rate | 1200, 2400, 4800, 9600 and 19.2k bits per second (See Section 6.6 "Software Operation" (4) for settings). |
| Character configuration | Start bit: 1 Data bits: 8 Parity: None Stop bits: 1 |
| Flow control | None |

A2.1.2 Communications Connector

| | |
|----------------|--|
| Connector | Rear panel RS-232C connector (See Section 2.1 "Power Supply Unit"). |
| Connector type | D-Sub 9-pin Male, Screw lock size:M2.6 |
| Pin assignment | 2 : RD (Receive data) 3 : SD (Transmit data) 4 : ER (Data terminal ready) 5 : SG (Signal ground) 7 : RS (Transmit request) * Other pins are not connected. ER and RS are on during the power supply unit's power up. |

A2.1.3 CABLE

(1) Cable Connection

Use the connection cable as shown in Figs. A-1 to connect the power supply and computer.
(Number on figure is pin number of connector.)

(2) Cable Length

Connection cables can be extended up to 15 meters, but may be subjects to errors depending on actual operational environment.

Appendix A COMMUNICATIONS

a. Cable wiring connections for 9-pin to 9-pin connector cables

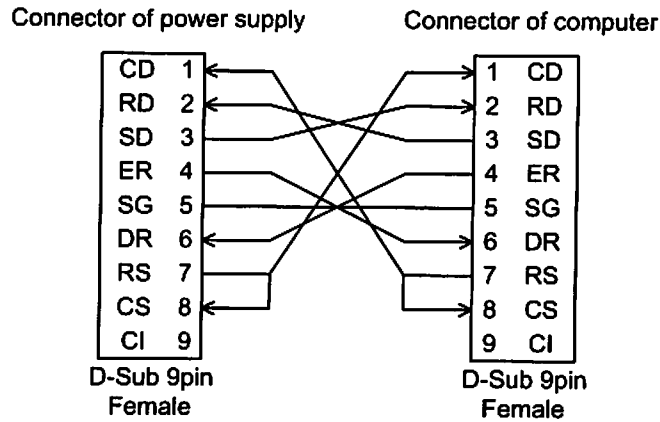

b. Cable wiring connections for 9-pin to 25-pin connector cables

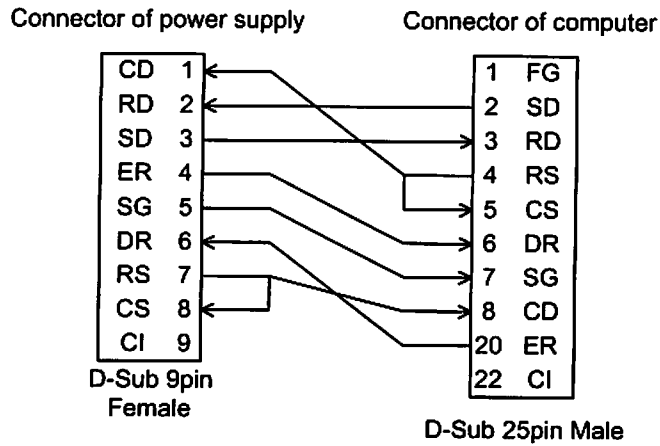

Fig. A-1 Example of RS-232 cable wiring connections

A2.2 RS-485

A

A2.2.1 Transmission Specification

| | |
|-------------------------|---|
| Interface | RS-485 |
| Synchronous system | Asynchronous |
| Transmission rate | 1200, 2400, 4800, 9600 and 19.2k bits per second (See Section 6.6 "Software Operation" (4) for settings). |
| Character configuration | Start bit: 1 Data bits: 8 Parity: None Stop bits: 1 |
| Flow control | None |
| Number of power supply | Multi-drop function OFF: 1 Multi-drop function ON: Max 32 (*1) |

*1 : There may be restrictions depending on cable length or cable type. Perform appropriate checks in the actual operating environment.

A2.2.2 Communications Connector

| | |
|----------------|---|
| Connector | Rear panel RS-485 connector (See Section 2.1 "Power Supply Unit"). |
| Connector type | D-Sub 9-pin Female, Screw lock size:M2.6 |
| Pin assignment | 1, 6 : RxA (Receive data +) 2, 7 : RxB (Receive data -) 3, 8 : TxB (Transmit data -) 4, 9 : TxA (Transmit data +) * Other pins are not connected. |

A2.2.3 CABLE

(1) Cable Connection

a. Multi-drop function OFF

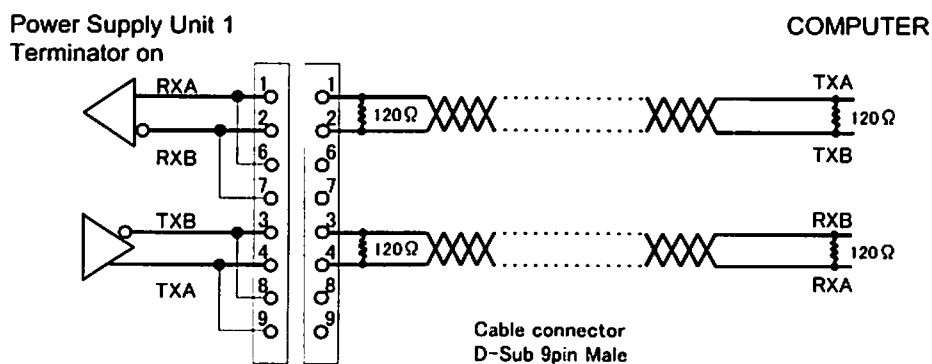

Fig. A-2 Example of RS-485 cable wiring connections (Multi-drop function OFF)

b. Multi-drop function ON

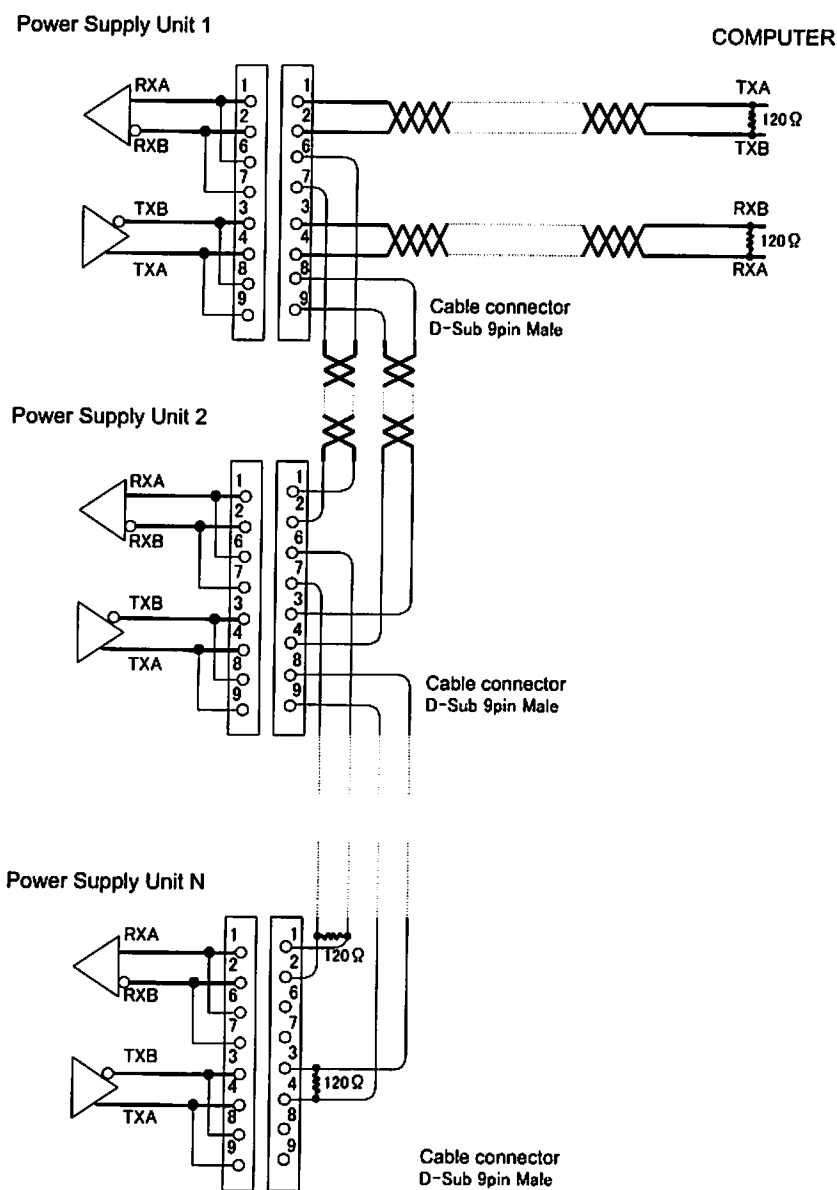

Fig. A-3 Example of RS-485 cable wiring connections (Multi-drop function ON)

(2) Cables used

RS-485 is a differential transmission and use twisted-pair cables in combinations as shown in Figs. A-2 and A-3.

(3) Connecting the terminator

A terminator (120 Ω, 1/4 W min.) is required for connection.

However, connection of the terminator may prevent communications with certain cable lengths and RS-485 device types. Connect the terminator to determine whether it is required.

(4) Cable Length

Connection cables can be extended up to 1.2 kilometers, but may be subjects to errors depending on actual operational environment.

A3. POWER SUPPLY TO COMPUTER CONNECTION

A3.1 Communication Cable Connection

Turn off the power supply unit and the computer to be connected. Connect the RS-232C connector on the power supply unit front panel or the RS-485 connector on the rear panel (refer to section 2.2 in this document, "Power Supply Unit") to the communications port of the computer with a cable, referring to section A2.

A3.2 Serial Communications Baud Rate Configuration

Check with a baud rate of a computer connected to, and set up a baud rate of RS-232C or RS-485. See Section 6.6 "Software Operation" (4) for details about the setting method.

A3.3 RS-485 Multi-drop Settings

The RS-485 interface multi-drop function is used to connect multiple power supply units to a single computer. Turn off the multi-drop function if the RS-485 is used instead of RS-232C to extend the communication cable length.

When the multi-drop function is turned on, the network ID portion of the sent character strings (see Section A4) is enabled and the event communication function that notifies the power supply unit status to the connected computer is disabled.

Set up the RS-485 as described below when using a multi-drop connection.

(1) Turn On the Multi-drop Function

Turn ON the multi-drop function using setting mode/RS485 setting/multi-drop setting on the LCD display. See Section 6.6 "Software Operation" (4) for details about the setting method.

(2) Setting the Network ID

The network ID is set using setting mode/RS485 setting/network ID setting on the LCD display to designate which power supply connected via the multi-drop connection the computer is sending commands to.

The network ID is set as a number between 01 and 32, and must be unique for each power supply connected to a computer. See Section 6.6 "Software Operation" (4) for details about the setting method.

When the RS-485 interface multi-drop function is turned ON, the event sending function (See A6.5) will be disabled, regardless of the SETTINGS/RS485/EVENT SENDING menu settings on the LCD display.

A4. SERIAL COMMUNICATIONS PROTOCOL

Communications software, between the power supply and customer equipment should be design according to the following specifications.

A4.1 Basic Message Structure

A basic transmit and receive message begins with the characters "MJ" and ends with a carriage return code (0dH : xxH means hexadecimal code). (See Table A-1)

The first message to be sent is referred as the COMMAND, while the reply to the command is referred as the ANSWER.

Table A-1 Basic structure of Commands and Answers

| Character | Hex. Code | Description | Number Of Bytes |
|-----------|-----------|--|-----------------|
| M | 4d | Command header characters | 2 |
| J | 4a | | |
| 0 | 30 | Network ID | 2 |
| 1 | 31 | Multi-drop function OFF: 01 fixed Multi-drop function ON: 01 to 32 | |
| X | xx | Command Characters | 2 |
| X | xx | | |
| | | Sub-command Characters | X |
| f | xx | Checksum characters (Calculation result by Section A4.7 enters it.) | 2 |
| f | xx | | |
| CR | 0d | Carriage return character | 1 |

A4.2 Character to Character Time-out: 0.1 sec.

Delays between characters, in the answer message, longer that 0.1 sec., shall be considered as a transmission line failure and special considerations should be made to re-send the message.

A5. TABLE OF COMMANDS

Table A-2 Table of Commands

| Type | Command/ answer | Name | Command character string | Sub-command character string | | |
|----------------------|--------------------|---------------------------------|--------------------------------|---------------------------------|----|----|
| Operation mode | Command | Operation mode check | LS | None | | |
| | | On-line request | LN | None | | |
| | | Off-line request | LF | None | | |
| | Answer | Local | LL | None | | |
| | | Remote | LR | None | | |
| | | RS-232C | LC | None | | |
| | | RS-485 | LD | None | | |
| Operation request | Command | START operation | RT | None | | |
| | | STOP operation | RP | None | | |
| | | RESET operation | RR | None | | |
| | Answer | Acceleration start | RA | None | | |
| | | Deceleration start | RB | None | | |
| | | Buzzer off | RZ | None | | |
| | | Failure occurred | RF | aa | *1 | |
| | | Failure elimination | RC | None | | |
| | | Operation invalid | RV | None | | |
| Run status | Command | Run status check | CS | None | | |
| | Answer | Stop | NS | aa | *1 | |
| | | Acceleration | NA | aa | *1 | |
| | | Normal rotation | NN | aa | *1 | |
| | | Deceleration | NB | aa | *1 | |
| | | Failure-Stop | FS | aa | *1 | |
| | | Failure-Free run | FF | aa | *1 | |
| | | Failure-Regenerative braking | FR | aa | *1 | |
| | | | Failure-Deceleration | FB | aa | *1 |
| | Command | Read alarm list | CF | aa | *5 | |
| Answer | Send alarm list | CA | aabb | *6 | | |
| | No alarm list | CV | aa | *5 | | |
| Parameters | Command | Read parameter | PR | aa | *2 | |
| | Answer | Send parameter | PA | aabbbb | *3 | |
| | | Invalid parameter number | PV | aa | *2 | |
| Event | Command | Failure occurred | EF | aa | *1 | |
| | | Rotation start | ER | None | | |
| | | Rotation stop | ES | None | | |
| | | Normal rotation | EN | None | | |
| | Answer | Event confirmation | EC | aa | *4 | |
| Timer | Command | Read timer | TR | aa | *7 | |
| | | Clear timer | TC | aa | *7 | |
| | | Write timer | TW | 06aaaaa | *8 | |
| | Answer | Send timer value | TA | aabbbbccc...cccd dd...ddd | *9 | |
| | | Invalid timer number | TV | aa | *7 | |

Appendix A COMMUNICATIONS

| | | | | | |
|---------------|---------|------------------------|----|-----------|-----|
| History | Command | Read alarm history | GA | aa | *10 |
| | Answer | Send alarm history | GB | xxx...xxx | *11 |
| | | No history data | GV | aa | *10 |
| Settings | Command | Read settings | SR | aa | *12 |
| | | Write settings | SW | aabbbb | *13 |
| | Answer | Send settings value | SA | aabbbb | *13 |
| | | Invalid setting number | SV | aa | *12 |
| | Command | Read user memo | SU | None | |
| | | Write user memo | SX | xxx...xxx | *14 |
| | Answer | Send user memo | SF | xxx...xxx | *14 |
| Shared answer | Answer | Invalid command | AN | None | |

*1 aa: Failure alarm codes (hexadecimal) corresponding to the protection system. See Table 7-6 "Table of Alarms" and Table 7-7 "Table of Warnings" in this manual for details.

*2 aa: Parameter number (decimal). See Table A-3 "Table of Parameters."

*3 aa: Parameter number (decimal). See Table A-3 "Table of Parameters."

bbbb: Parameter value (decimal). See Table A-3 "Table of Parameters."

*4 aa: Confirm event command character string

Send the unchanged command character string of the confirmed event command.

Example: Failure occurred → "EF"

*5 aa: Alarm list number (decimal)

*6 aa: Alarm list number (decimal)

bb: Alarm code (decimal) stored in the alarm list with the requested number.

See Table 7-6 "Table of Alarms" and Table 7-7 "Table of Warnings" in this manual for details.

*7 aa: Timer number (decimal). See Table A-4 "Table of Timers."

*8 06 (fixed): Timer number (decimal). See Table A-4 "Table of Timers."

aaaaa: Set value (decimal). See Table A-4 "Table of Timers."

*9 aa: Timer number (decimal). See Table A-4 "Table of Timers."

bbbbbb: Timer value (decimal). See Table A-4 "Table of Timers."

ccccccccc: Time when the timer updated. (YYMMDDHHMM format. Stored as Greenwich Mean Time)

ddddddddd: Time when the timer reset. (YYMMDDHHMM format. Stored as Greenwich Mean Time)

*10 aa: History number

*11 xxx...xxx: See Table A-5 "Alarm History Data Format."

*12 aa: Settings number (decimal). See Table A-6 "Table of Settings."

*13 aa: Settings number (decimal). See Table A-6 "Table of Settings."

bbbb: Set value (decimal). See Table A-6 "Table of Settings."

*14 xxx...xxx: Any 20-character displayable character string.

Table A-3 Table of Parameters

| No. | Name | Range | Description and format |
|-----|-------------------------------------|--------------|--|
| 01 | Model identification number | Fixed | Value representing the model. Example: EI-D3203M → 3203 |
| 03 | Rotational speed | 0000 to 5000 | Rotational speed / 10 Example: 15000 rpm → 1500 |
| 04 | Motor current | 0000 to 0150 | Motor drive current x 10 Example: 2.3 A → 0023 |
| 05 | Pump temperature | 0000 to 0099 | Pump temperature 45°C → 0045 (Valid only for a power supply with a temperature control function.) |
| 07 | Temperature control function | 0000 to 0002 | Temperature control function setting status 0000: Temperature control function on 0001: Temperature control function off 0002: Power supply has no temperature control function |
| 08 | Temperature control set temperature | Fixed | Target value of temperature control setting Example: 65°C → 0065 (Valid only for a power supply with a temperature control function.) |
| 09 | Rotational speed (%) | 0000 to 0100 | Percentage of rated rotational speed. Example: 80% → 0080 |
| 10 | Rotational speed (%) | 0000 to 1000 | Percentage of rated rotational speed. (x10) Example: 80% → 0800 |
| 11 | Rated rotational speed | 0000 to 5000 | Rated rotational speed / 10 Example: 21000 rpm → 2100 |
| 21 | Axis 1 unbalance monitor amount | 0000 to 100 | Unbalance monitor value of magnetic bearing: Axis 1 Example: 3% → "0003" |
| 22 | Axis 2 unbalance monitor amount | 0000 to 0100 | Unbalance monitor value of magnetic bearing: Axis 2 Example: 3% → "0003" |
| 26 | MB sensor output X1 | 0000 to 0100 | Sensor output monitor value of magnetic bearing: Axis X1 Example: 3% → "0003" |
| 27 | MB sensor output Y1 | 0000 to 0100 | Sensor output monitor value of magnetic bearing: Axis Y1 Example: 3% → "0003" |
| 28 | MB sensor output X2 | 0000 to 0100 | Sensor output monitor value of magnetic bearing: Axis X2 Example: 3% → "0003" |
| 29 | MB sensor output Y2 | 0000 to 0100 | Sensor output monitor value of magnetic bearing: Axis Y2 Example: 3% → "0003" |
| 30 | MB sensor output Z | 0000 to 0100 | Sensor output monitor value of magnetic bearing: Axis Z Example: 3% → "0003" |

Table A-4 Table of Timer

| No. | Name | Range | Description and format |
|-----|--------------------------------|----------------|---|
| 01 | Run time | 00000 to 99999 | Read the timer value in the "MENU MODE / INTEGRAL TIMER / RUN TIME" on the LCD display. (Can not be reset. Reset date is invalid.) Example: 0 → 00000, 99999 → 99999 |
| 02 | Last maintenance time | 00000 to 99999 | Read the timer value in the "MENU MODE / INTEGRAL TIMER / LAST MAINT." on the LCD display. (Can be reset) Example: 0 → 00000, 99999 → 99999 |
| 03 | Power failure touch-down count | 00000 to 00999 | Read the timer value in the "MENU MODE / INTEGRAL TIMER / POWER FAILURE" on the LCD display. (Can be reset) Example: 0 → 00000, 999 → 00999 |
| 04 | High-speed touch-down count | 00000 to 00999 | Read the timer value in the "MENU MODE / INTEGRAL TIMER / MB ALARM" on the LCD display. (Can be reset) Example: 0 → 00000, 999 → 00999 |
| 05 | MB warning counter | 00000 to 00999 | Read the timer value in the "MENU MODE / INTEGRAL TIMER / MB WARNING" on the LCD display. (Can be reset) Example: 0 → 00000, 999 → 00999 |
| 06 | Maintenance call time | 00000 to 99999 | Read or change the timer value in the "MENU MODE / INTEGRAL TIMER / MAINT.CALL" on the LCD display. Example: 0 → 00000, 99999 → 99999 |

Table A-5 Alarm History Data Format

| | Item | Number of bytes | Data | Comments |
|---|------------------------------|-----------------|---------------|--|
| 1 | History number | 2 | 01 to 99 | History number designated by the command. |
| 2 | Time | 10 | YYMMDDHHMM | Time when the failure occurred (stored as Greenwich Mean Time) YY: year, MM: month, DD: day, HH: hour, MM: minutes |
| 3 | Alarm number | 2 | 00 to 99 | Alarm number of the failure that occurred. See Table 7-6 "Table of Alarms" and Table 7-7 "Table of Warnings" in this manual for details. |
| 4 | Run status | 2 | NS, NA, NN... | Run status when the failure occurred. Data is identical to CS command answer. |
| 5 | Rotational speed | 4 | 0000 to 0100 | Speed when the failure occurred. Format is identical to 09 in Table A-3. |
| 6 | Motor current | 4 | 0000 to 0150 | Motor current in the event of a fault. The format is the same as No.04 in Table A-3. |
| 7 | Pump temperature | 2 | 00 to 99 | Pump temperature in the event of a fault. The format is equivalent to the last two characters of No.05 in Table A-3. (Valid only for a power supply with a temperature control function.) |
| 8 | Temperature control function | 2 | 00, 01, 02 | Temperature control function when the failure occurred. Format is equivalent to last 2 characters of 07 in Table A-3. |

A5. TABLE OF COMMANDS



| | Item | Number of bytes | Data | Comments |
|----|-------------------------------------|-----------------|---|---|
| 9 | Temperature control set temperature | 2 | 55, 65 (EI-D303MT to EI-D1303MT) 55, 65, 75 (EI-D2003MT to EI-D4203MT) | Temperature control set temperature when the failure occurred. Format is equivalent to last 2 characters of 08 in Table A-3. (Valid only for a power supply with a temperature control function.) |
| 10 | Axis 1 unbalance monitor amount | 4 | 0000 to 0100 | Unbalance monitor value of magnetic bearing when a fault occurs: Axis 1 Format is the same as No.21 in Table A-3. |
| 11 | Axis 2 unbalance monitor amount | 4 | 0000 to 0100 | Unbalance monitor value of magnetic bearing when a fault occurs: Axis 2 Format is the same as No.22 in Table A-3. |
| 12 | MB sensor output X1 | 4 | 0000 to 0100 | Sensor output monitor value of magnetic bearing when a fault occurs: Axis X1 Format is the same as No.26 in Table A-3. |
| 13 | MB sensor output Y1 | 4 | 0000 to 0100 | Sensor output monitor value of magnetic bearing when a fault occurs: Axis Y1 Format is the same as No.27 in Table A-3. |
| 14 | MB sensor output X2 | 4 | 0000 to 0100 | Sensor output monitor value of magnetic bearing when a fault occurs: Axis X2 Format is the same as No.28 in Table A-3. |
| 15 | MB sensor output Y2 | 4 | 0000 to 0100 | Sensor output monitor value of magnetic bearing when a fault occurs: Axis Y2 Format is the same as No.29 in Table A-3. |
| 16 | MB sensor output Z | 4 | 0000 to 0100 | Sensor output monitor value of magnetic bearing when a fault occurs: Axis Z Format is the same as No.30 in Table A-3. |
| 17 | Operation time | 6 | 000000 to 099999 | Operation time when a fault occurs. Format is the same as No.01 in Table A-4. |

Table A-6 Table of Settings

| No. | Name | Range | Description and format |
|-----|-----------------------------------|--------------|---|
| 01 | Temperature control on/off | 0000 / 0001 | Read or change the set values in the "MENU / SETTINGS / TEMP.CONTORL / TEMP.CONTROL" on the LCD display. 0000: Temperature control function on 0001: Temperature control function off (Valid only for a power supply with a temperature control function.) |
| 02 | Speed display format | 0000 to 0002 | Read or change the set values in the "MENU / SETTINGS / ROT.SPEED / DISPLAY" on the LCD display. 0000: %, 0001: rpm, 0002: rps |
| 03 | Rotational speed | 0000 / 0001 | Read or change the set values in the "MENU / SETTINGS / ROT.SPEED / SPEED" on the LCD display. 0000: NORMAL, 0001: LOW SPEED |
| 04 | Low speed value | 0025 to 0100 | Read or change the set values in the "MENU / SETTINGS / ROT.SPEED / LOW SPEED" on the LCD display. Example: 25% → 0025, 100% → 0100 |
| 05 | "ALARM" signal operation setting | 0000 / 0001 | Read or change the set values in the "MENU / SETTINGS / REMOTE SIGNAL MODE / ALARM" on the LCD display. 0000: SEMI-E74, 0001: EI-03 |
| 06 | "REMOTE" signal operation setting | 0000 / 0001 | Read or change the set values in the "MENU / SETTINGS / REMOTE SIGNAL MODE / REMOTE" on the LCD display. 0000: SEMI-E74, 0001: EI-03 |
| 07 | "STOP" signal operation setting | 0000 / 0001 | Read or change the set values in the "MENU / SETTINGS / REMOTE SIGNAL MODE / STOP" on the LCD display. 0000: REMOTE ONLY, 0001: REMOTE&RSXXX |
| 08 | Low rotation speed | 0250 to 1000 | Read or change the set values in the "MENU / SETTINGS / ROT.SPEED / LOW SPEED" on the LCD display. Example: 25.0% → 0250, 99.9% → 0999 |

A6. COMMAND DESCRIPTION

A6.1 Operation Mode

| | | |
|----------|----|---|
| Commands | LS | <p>Operation mode check</p> <p>Enables operation mode verification (LOCAL / REMOTE / RS-232C / RS-485)</p> <p>Action: Power supply returns an ANSWER showing present operation mode.</p> |
| | LN | <p>ON-LINE request</p> <p>If the current operation mode is REMOTE, the operation mode is shifted to RS-232C or RS-485. This command is ineffective in other operation modes.</p> <p>Action: Power supply returns an ANSWER showing the present operation mode.</p> |
| | LF | <p>OFF-LINE request</p> <p>If the current operation mode is RS-232C or RS-485, the operation mode is shifted to REMOTE. This command is ineffective in other operation modes.</p> <p>Action: Power supply returns an ANSWER showing the present operation mode.</p> |
| Answers | LL | <p>Operation mode LOCAL</p> <p>This answer is returned when the operation mode is LOCAL.</p> <p>The operation mode can also be shifted to LOCAL mode by the front panel REMOTE/LOCAL selection switch.</p> |
| | LR | <p>Operation mode REMOTE</p> <p>This answer is returned when the operation mode is REMOTE.</p> <p>The operation mode can also be shifted to REMOTE mode by the front panel REMOTE/LOCAL selection switch or when in the RS-232C or RS-485 operation mode by the "OFF-LINE" request command.</p> |
| | LC | <p>Operation mode RS-232C</p> <p>This answer is returned when the operation mode is RS-232C. The operation mode is shifted to RS-232C when the "ON-LINE" request command is sending via RS-232C in the remote operation mode.</p> |
| | LD | <p>Operation mode RS-485</p> <p>This answer is returned when the operation mode is RS-485. The operation mode is shifted to RS-485 when the "ON-LINE" request command is sending via RS-485 in the remote operation mode.</p> |

A6.2 Operation

| | | |
|----------|----|--|
| Commands | RT | <p>START Operation</p> <p>This command is the equivalent of pressing the front panel START switch.</p> <p>Action: The turbo molecular pump starts accelerating and sends the "Acceleration Start" answer.</p> |
| | RP | <p>STOP Operation</p> <p>This command is the equivalent of pressing the front panel STOP switch.</p> <p>Action: The turbo molecular pump starts decelerating and sends the "Deceleration Start" answer.</p> |
| | RR | <p>RESET Operation</p> <p>This command is the equivalent of pressing the front panel RESET switch.</p> <p>Action: This command is effective against failures. This command resets the alarm buzzer sound and returns the "Buzzer Off" answer. If the buzzer is already off, this command resets the ALARM. If the cause of the alarm is eliminated after resetting, the "Failure Elimination" answer will be returned, else the buzzer will sound again and the "Failure occurrence " Answer is sent back.</p> |
| Answers | RA | <p>Acceleration Start</p> <p>This answer is returned by the power supply after the acceleration is started on a START operation.</p> |
| | RB | <p>Deceleration Start</p> <p>This answer is returned by the power supply after the deceleration is started on a STOP operation.</p> |
| | RZ | <p>Buzzer Off</p> <p>This answer is returned by the power supply after the buzzer is turned off on a RESET operation.</p> |
| | RC | <p>Failure elimination</p> <p>This answer is returned by the power supply after the failure cause is removed after the power supply is reset on a RESET operation.</p> |
| | RF | <p>Failure Occurrence</p> <p>This answer is returned by the power supply if the failure cause is not removed after the power supply is reset on a RESET operation. The alarm code of the failure that has not been eliminated is returned as a 2-character sub-command.</p> |
| | RV | <p>Operation invalid</p> <p>This answer is returned if the operation is invalid (START operation command sent during acceleration) or if the operation mode differs from the port that sent the command (operation mode is RS-485 but operation command was sent from the RS-232C port).</p> |

A6.3 Run Status



| | | |
|----------|----------|---|
| Commands | CS | Run Status Check This command requests the current power supply status. |
| Answers | NS | Stop This answer is returned when the pump stops. Equivalent to the monitor mode/ STOP run status on the LCD display. For a normal status, "00" is returned as the sub-command. If a warning has occurred, the 2-character alarm code is returned as the sub-command. |
| | NA | Acceleration This answer is returned during pump acceleration. Equivalent to the monitor mode/ ACC. run status on the LCD display. For a normal status, "00" is returned as the sub-command. If a warning has occurred, the 2-character alarm code is returned as the sub-command. |
| | NN | Normal rotation This answer is returned during normal pump rotation. Equivalent to the monitor mode/NORMAL run status on the LCD display. For a normal status, "00" is returned as the sub-command. If a warning has occurred, the 2-character alarm code is returned as the sub-command. |
| | NB | Deceleration This answer is returned during pump deceleration. Equivalent to the monitor mode/ BRAKE run status on the LCD display. For a normal status, "00" is returned as the sub-command. If a warning has occurred, the 2-character alarm code is returned as the sub-command. |
| | FS | Failure-Stop This answer is returned when the pump is stopped after a failure occurs. Equivalent to the monitor mode/E-STOP run status on the LCD display. The 2-character alarm code is returned as the sub-command. |
| | FF | Failure-Free run This answer is returned when the pump is free-running (neither accelerating nor decelerating) after a failure occurs. Equivalent to the monitor mode/E-IDLE run status on the LCD display. The 2-character alarm code is returned as the sub-command. |
| | FR | Failure-Regenerative braking This answer is returned when the pump is regenerative braking after a failure occurs. Equivalent to the monitor mode/E-BRAKE run status on the LCD display. The 2-character alarm code is returned as the sub-command. |
| | FB | Failure-Deceleration This answer is returned when the pump is decelerating after a failure occurs. Equivalent to the monitor mode/E-BRAKE run status on the LCD display. The 2-character alarm code is returned as the sub-command. |
| | Commands | CF |
| Answers | CA | Send alarm list Returns the alarm code corresponding to the requested alarm list number. The sub-command returns a 2-character alarm list number and a 2-character alarm code. |
| | CV | No alarm list This answer is returned if no alarm corresponds to the requested alarm list number. The sub-command returns a 2-character alarm list number. |

A6.4 Parameters

| | | |
|----------|----|--|
| Commands | PR | Read parameter Reads the parameter value for a designated parameter number. Sends the 2-character parameter number as the sub-command. |
| Answers | PA | Send parameter Returns the parameter value for the designated parameter number. The 2-character parameter number + 4-character parameter value is returned as the sub-command in the format shown in Table A-3 "Table of Parameters." |
| | PV | Invalid parameter number This answer is returned if the designated parameter number is invalid. Returns the 2-character parameter number as the sub-command. |

A6.5 Events

For the event functions only, commands are sent from the power supply unit to the connected computer, and the answers are sent from the computer to the power supply unit.

This function can also be disabled by setting the SETTINGS/RS232C/EVENT SENDING or SETTINGS/RS485/EVENT SENDING menu setting to OFF on the LCD display.

This function will be disabled automatically if the RS485 multi-drop function is enabled.

In the default status, command ER is transmitted when either an alarm or warning occurs.

However, if the warning output setting is OFF in the menu mode SETTINGS/WARNING DISPLAY item on the LCD, command ER is not transmitted when warnings of alarm codes 86 to 94 (Table 7-7 "Table of Warnings") occur.

| | | |
|----------|----|--|
| Commands | EF | Failure occurred Sent to the connected computer when an failure occurs. The 2-character alarm code for the failure is sent as the sub-command. |
| | ER | Start rotation Sent to the connected computer when pump rotation starts. Equivalent to the ROTATION lamp lighting. |
| | ES | Stop rotation Sent to the connected computer when pump rotation stops. Equivalent to the ROTATION lamp going out. |
| | EN | Normal speed Sent to the connected computer when the normal rotation speed is achieved. Equivalent to the NORMAL SPEED lamp lighting. |
| Answers | EC | Confirm event Return this answer to the power supply unit when an event is received from the power supply unit. The power supply unit sends the command up to five times at one-second intervals until it receives the confirm event answer. Send the 2-character command character string for the received event command as a sub-command. |

A6.6 Timer

| | | |
|----------|----|--|
| Commands | TR | Read timer Reads the timer value for a designated timer number. Sends the 2-character timer number as the sub-command. |
| | TC | Clear timer Clears the timer value for a designated timer number. Sends the 2-character timer number as the sub-command. |
| | TW | Write timer Overwrites the set value for a maintenance call timer. Sends the 2-character settings number + 5-character set value data as the sub-command. |
| Answers | TA | Send timer value Returns the timer value for the designated timer number. The 2-character timer number + 5-character timer value is returned as the sub-command in the format shown in Table A-4 "Table of Timers." |
| | TV | Invalid timer number This answer is returned if the designated timer number is invalid. Returns the 2-character timer number as the sub-command. |

A6.7 History

| | | |
|----------|----|---|
| Commands | GA | Read alarm history Reads the alarm history for a designated alarm history number. Sends the 2-character alarm history number as the sub-command. |
| Answers | GB | Send alarm history Returns the alarm history for the designated alarm history number. The 64-character alarm history data is returned as the sub-command in the format shown in Table A-5 "Alarm History Data Format." |
| | GV | No history data This answer is returned if no alarm history data corresponds to the designated alarm history number. Returns the 2-character alarm history number as the sub-command. |

| | | |
|--|----|--|
| | TR | Read timer Reads the timer value for a designated timer number. Sends the 2-character timer number as the sub-command. |
|--|----|--|

A6.8 Settings

| | | |
|----------|----|--|
| Commands | SR | Read settings Reads the set value for a designated settings number. Sends the 2-character settings number as the sub-command. |
| | SW | Write settings Overwrites the set value for a designated settings number. Sends the 2-character settings number + 4-character set value data as the sub-command. |
| Answers | SA | Send settings value Returns the set value for the designated settings number. The 2-character settings number + 4-character set value is returned as the sub-command. |
| | SV | Invalid setting number This answer is returned if the designated settings number is invalid. Returns the 2-character settings number as the sub-command. |
| Commands | SU | Read user memo Reads the character string in the user memo. |
| | SX | Write user memo Overwrites the character string in the user memo. Sends the 20 characters to set in the user memo as the sub-command. If less than 20 characters are set, the remaining characters are filled with spaces. Be sure to always send 20 characters. |
| Answers | SF | Send user memo Returns as a sub-command the set user memo character string or the 20-character user memo character string overwritten by the SX command. |

A6.9 Shared Answer

| | | |
|---------|----|--|
| Answers | AN | Invalid Command Answer returned by the power supply after it receives an invalid command. |
|---------|----|--|

| | | |
|--|----|--|
| | SR | Read settings Reads the set value for a designated settings number. |
|--|----|--|

A7. RS-232C COMMANDS / ANSWERS (SEND AND RECEIVE Examples)

Table A-7 RS-232C COMMANDS / ANSWERS (SEND AND RECEIVE Examples)

| Type | Computer (Host) *1 | Send/Receive *2 | Power Supply | Description | Remarks | |
|----------------|--------------------|-----------------|-----------------------|--|--|--|
| Operation Mode | MJ01LS97\$ | → | | Operation Mode Check | | |
| | | ← | MJ01LL90\$ | LOCAL | | |
| | | | MJ01LR96\$ | REMOTE | | |
| | | | MJ01LC87\$ | RS-232C | | |
| | | | MJ01LD88\$ | RS-485 | | |
| | | MJ01LN92\$ | → | | ON-LINE Request | ON-LINE request from RS-232C communication port |
| | | ← | MJ01LC87\$ | Operation Mode Change | Operation mode changed to RS-232C ON-LINE | |
| | | | MJ01LD88\$ | Invalid Request | When in RS-485 mode | |
| | | | MJ01LL90\$ | Invalid Request | When in LOCAL mode | |
| | | MJ01LF8A\$ | → | | OFF-LINE Request | OFF-LINE request from RS-232C communication port |
| | | ← | MJ01LR96\$ | Operation Mode Change | Operation mode changed to REMOTE | |
| | | | MJ01LD88\$ | Invalid Request | When in RS-485 mode | |
| | MJ01LL90\$ | | Invalid Request | When in LOCAL mode | | |
| TMP Operation | MJ01RT9E\$ | → | | START Operation | START operation from RS-232C communication port | |
| | | ← | MJ01RA8B\$ | Acceleration Start | | |
| | | | MJ01RVA0\$ | Ineffective Operation | When START operation is ineffective or operation mode is not RS-232C | |
| | MJ01RP9A\$ | → | | STOP Operation | STOP operation from RS-232C communication port | |
| | | ← | MJ01RB8C\$ | Deceleration Start | | |
| | | | MJ01RVA0\$ | Ineffective Operation | When STOP operation is ineffective or operation mode is not RS-232C | |
| | MJ01RR9C\$ | → | | RESET Operation | RESET operation from RS-232C communication port | |
| | | ← | MJ01RZA4\$ | Buzzer Off | When a buzzer sounded | |
| | | | MJ01RF50F5\$ | Failure Occurrence | When the failure was not eliminated. | |
| | | | MJ01RC8D\$ | Failure Eliminated | When the failure was eliminated. | |
| | MJ01RVA0\$ | | Ineffective Operation | When RESET operation is ineffective or operation mode is not RS-232C | | |

Appendix A COMMUNICATIONS

A

| Type | Computer (Host) *1 | Send/Receive *2 | Power Supply | Description | Remarks |
|------------|--------------------|-----------------|--------------------------------------|--------------------------|--|
| Run Status | MJ01CS8E\$ | → | | Run Status Check | |
| | | ← | MJ01NS00F9\$ | Stop | |
| | | | MJ01NA00E7\$ | Acceleration | |
| | | | MJ01NB00E8\$ | Deceleration | |
| | | | MJ01NN00F4\$ | Normal Rotation | |
| | | | MJ01FS1C05\$ | Failure Stop | LCD: "TMP:CAN NOT START" |
| | | | MJ01FF32E9\$ | Failure Idle | LCD: "EI:DC-DC OVERTEMP" |
| | | | MJ01FR15F6\$ | Failure Regeneration | LCD: "POWER FAILURE" |
| | | | MJ01FB60E6\$ | Failure Deceleration | LCD: "MB:VIBRATION 1 Z" |
| | | MJ01CF01E2\$ | → | | Read Alarm List |
| | | ← | MJ01CA011543\$ | Send Alarm List | Power failure occurred. |
| Parameter | MJ01PR03FD\$ | → | | Read Parameter | Parameter 03 (rotational speed) |
| | | ← | MJ01PA032700B5\$ | Send Parameter | Data = 2700 (27,000 rpm) |
| | MJ01PR1500\$ | → | | Read parameter | Parameter 10 (invalid number) |
| | | ← | MJ01PV1504\$ | Invalid parameter number | |
| Event | | ← | MJ01EF15E9\$ | Failure Occurrence | Power failure occurred. |
| | MJ01ECEFB\$ | → | | Event Confirmation | |
| | | ← | MJ01ER8F\$ | Rotation Start | |
| | MJ01ECER17\$ | → | | Event Confirmation | |
| | | ← | MJ01ES90\$ | Rotation Stop | |
| | MJ01ECES18\$ | → | | Event Confirmation | |
| | | ← | MJ01EN8B\$ | Normal Rotation | |
| Timer | MJ01TR01FF\$ | → | | Read Timer | Timer 01 (Run time) |
| | | ← | MJ01TA01001350304051500000000000B9\$ | Send Timer | Timer 01 = 135 (135 hours) Last update: 2003/4/5 15:00 Last reset: (invalid) |
| | MJ01TW030000F6\$ | → | | Clear Timer | Clear timer 03 (Number of power failure touch-downs.) |
| | | ← | MJ01TA0300000E0\$ | Timer Value | Timer 03 = 0 Value cleared. |

A9. TROUBLESHOOTING

A9.1 No Message can Transmit and Receive

(1) Start the pump in LOCAL mode and check if the event command of Rotation start can be received in the timing at which ROTATION lamp lights.

Could be received >> check if command from connected computer can be received or not, using another computer, etc.

A nonsensical character string was received >> Go to A9.2.

c. Not receivable >> (2)

(2) Check the connection of RS-232C cable in reference to A2.

Check the polarity of RS-485 interface, because there is the case that polarity is reverse.

(3) Check the transmission specification of RS-232C at computer side.

A9.2 Sending and Receiving are Done, But Receivable Messages are Invalid

(1) Check the transmission rate of the power supply unit and computer.

A9.3 Characters Get Disordered from Time to Time, Then Resulting in CHECKSUM Error

(1) Remove the cable from equipment as noise source if it runs near it.

(2) When the cable in use is not a shield cable, replace it with the latter cable.

When shield cable is used, be sure to check that it is connected to the frame gland of the connected computer.

Use twisted pair cable when RS-485 is used.

(3) When 10 m or longer cable is used, replace it with another cable as short as possible.

(4) Make the transmission rate smaller unless there is problem in application program .

This page is intentionally left blank.

Index

A

| | |
|---------------------|------------|
| ALARM | 69 |
| Alarm history | 14, 15, 49 |
| Alarm mode | 43, 49 |

C

| | |
|---------------------|-------|
| Control Cable | 4, 24 |
|---------------------|-------|

H

| | |
|---|----|
| How to install the unit onto a rack | 18 |
|---|----|

M

| | |
|--------------------|----------------|
| Menu mode | 43, 50, 52, 57 |
| Monitor mode | 47 |
| Motor Cable | 4 |

P

| | |
|---------------------|--------|
| power failure | 14, 15 |
| Power switch | 9 |

R

| | |
|------------------------------|-----------|
| REMOTE signal | 55 |
| remote-control signal | 55 |
| Remote-Control Signals | 59 |
| Reset Procedure | 70 |
| RS-232C | 52, 53, 3 |
| RS-485 | 52, 53, 5 |

S

| | |
|------------------------|-------|
| SEMI F47 | 16 |
| SEMI S2 | 16 |
| serial interface | 12, 2 |

U

| | |
|----------|----|
| UL | 16 |
|----------|----|

This page is intentionally left blank.

Declaration of Conformity

SHIMADZU CORPORATION SEMICONDUCTOR EQUIPMENT DIVISION

**Address :380-1,HORIYAMASHITA,HADANO-CITY,
KANAGAWA, 259-1304, JAPAN**

as the Manufacturer

declares in sole responsibility that the following product

Product Name Turbo Molecular Pump

Model name , P/N

| Vacuum Pump | | Power Supply | |
|--------------------------------|--------------|------------------|--------------|
| Model name | P / N | Model name | P / N |
| TMP-803LM/LMC/M/MC | 262-81453-xx | EI-D1003M | 262-78689-xx |
| TMP-1003LM/LMC/M/MC | 262-81410-xx | | |
| TMP-1103LMP/LMPC/MP/MPC | 262-78492-xx | EI-D1103M | 262-78690-xx |
| TMP-1303LM/LMC/M/MC | 262-81475-xx | EI-D1303M | 262-78688-xx |
| TMP-2003LM/LMC/M/MC | 262-81439-xx | EI-D2003M | 262-78691-xx |
| TMP-2203LM/LMC/M/MC | 262-78453-xx | EI-D2203M | 262-78692-xx |
| TMP-3203LM/LMC/M/MC | 262-78430-xx | EI-D3203M | 262-78685-xx |
| TMP-3403LM/LMC/M/MC | 262-78503-xx | EI-D3403M | 262-78694-xx |
| TMP-4203LM/LMC/M/MC | 262-78512-xx | EI-D4203M | 262-78696-xx |

Note: -xx (P/N) means 00 to 99 or blank

referred to in this declaration conforms with following directives and standards

Machinery directive 98/37/EC amended by 98/79/EC

**EN292-1:1991, EN292-2:1991+A1:1995,
EN1012-2:1996**

Low Voltage directive 73/23/EEC amended by 93/68/EEC

**EN61010-1:1993+A2:1995
EN61010-1:2001**

EMC directive 89/336/EEC amended by 91/263/EEC, 92/31/EEC, 93/68/EEC, 93/97/EEC

EN61326:1997+A1:1998+A2:2001, class A

Note 1) This declaration becomes invalid if technical or operational modifications are introduced without manufacturer's consent.

Note 2) This declaration is valid if this product is used alone or in combination with the accessories of this product or other instruments which fulfill with the requirement of mentioned directive.

Note3) Importer/Distributor and Authorized Representative in EU is as follows:

KRATOS ANALYTICAL LTD.

Address : Whartisid, Trafford Wharf Road, Manchester M17 1GP England

Hadano, JAPAN, 3 April 2003.
place and date of issue



signature

Shinzo Inoue

name

Manager of Quality Assurance Dept.

Semiconductor Equipment Division

Shimadzu Corporation

Position

SHIMADZU CORPORATION SEMICONDUCTOR EQUIPMENT DIVISION

**Address :380-1,HORIYAMASHITA,HADANO-CITY,
KANAGAWA, 259-1304, JAPAN**

as the Manufacturer

declares in sole responsibility that the following product

TMP overhaul / repair request form

Please fill out this request form and attach to the product before you send back to Shimadzu service center for overhaul or repair service. We ask that you fill out this form completely to expedite the service and return shipment.

Please mark the item box, and fill out the blank.

| | |
|--|--|
| (1) Product | <input type="checkbox"/> Pump (TMP-) s/n () <input type="checkbox"/> Controller (EI-) s/n () |
| (2) Request | <input type="checkbox"/> Overhaul <input type="checkbox"/> Repair <input type="checkbox"/> Other |
| (3) Details | |
| (4) Alarm code | (If status lamp indicates, No is) |
| (5) Date of failure occurrence () | (6) Date for return shipment request () |
| (7) Date of TMP operation start () | (8) Date of previous delivery () |
| (9) Parts exchange recommendation | <p>If any parts exchange is recommended due to the excess of usage recommendation period.</p> <p><input type="checkbox"/> (a) Please exchange the parts.</p> <p><input type="checkbox"/> (b) Don't exchange unless any deterioration is found in the inspection.</p> <p style="text-align: center;">In case of (b), even if any failure occurs with the cause of parts for which customers choose continuous usage, it's out of warranty. Especially at rotor, it causes the material deterioration which even the fluorescent penetrant test can't detect after long term running. For this reason, periodical exchange is recommended in order to use the rotor safely.</p> |
| (10) Declaration of contamination | <p style="text-align: center; background-color: black; color: white; padding: 2px;">Please fill out the following items to make sure of our safety.</p> <p>Components which have been contaminated by hazardous substrates will not be accepted or served without written evidence of decontamination.</p> <ul style="list-style-type: none"> - Equipment process <input type="checkbox"/> Etch <input type="checkbox"/> PVD <input type="checkbox"/> CVD <input type="checkbox"/> Others () - Materials the equipment has been exposed to () (Etched material, CVD/PVD target, etc) - Gases the equipment has been exposed to <li style="padding-left: 20px;"><input type="checkbox"/> Air, Nitrogen, etc () <input type="checkbox"/> Reactive/active gas () <li style="padding-left: 20px;"><input type="checkbox"/> Inert gas such as helium, etc () <input type="checkbox"/> Virulent gas () <li style="padding-left: 20px;"><input type="checkbox"/> Corrosive gas () <input type="checkbox"/> Others () - Is it hazardous to human ? <input type="checkbox"/> Yes <input type="checkbox"/> No - Is there color change or adhesion at inlet or outlet flange ? <input type="checkbox"/> Yes <input type="checkbox"/> No <li style="padding-left: 20px;">(If yes, please let us perform TMP cleaning at additional charge to keep appropriate performance. - Precaution and procedure for decontamination in case it's necessary at Shimadzu. <li style="padding-left: 20px;">() |
| (11) Gas purge | <input type="checkbox"/> Used (sccm) <input type="checkbox"/> Not used |
| <p>I declare that the TMP being returned doesn't contain any amount of hazardous residues that exceed the permissible exposure limits on the MSDS and that the information provided above is complete and accurate.</p> <p style="text-align: right;">Date ()</p> <p>Company () Job title ()</p> <p>Name () Signature ()</p> <p>Phone () Fax ()</p> | |

「電子情報製品汚染防止管理弁法」(中華人民共和國 信息産業部発行)に基づく、
「環境保護使用期限」と「製品中の有毒有害物質または元素の名称および含有量」表示

Markings regarding the "Environmental Protection Use Period" and the "Names and Contents of Toxic or Hazardous Substances or Elements" for "Management Methods for Controlling Pollution by Electronic Information Products" (Issued by: Ministry of Information Industry of the People's Republic of China)

Model Name

Pump Unit : TMP-03 series
Power Supply : EI-Dxx03M/MT series

環境保護使用期限 [环保使用期限标识]
Environmental Protection Use Period



この環境保護使用期限標識(マーク)は【電子情報製品汚染防止管理弁法】及び【電子情報製品汚染防止標識に関する要求】に基づき策定され、中国国内で販売される電子情報製品に適用されます。マーク中央の数字は、環境保護使用期限の年数です。この製品に関する安全や使用上の注意をお守りいただく限り、製造日から起算するこの年限内では、有害・有毒物質または元素が外部へ漏れ出したり変化をおこしたりせず、重大な環境汚染や人体や財産に影響を及ぼすことはありません。なお、この標識の期限は、製品の品質や機能に関する保証期間と異なります。

[环保使用期限标识(标记)是根据《电子信息产品污染控制管理办法》以及《电子信息产品污染控制标识要求》制定的,适用于在中国境内销售的电子信息产品。标记中央处的数字即为环保使用期限的年数。只要遵守相关产品安全与使用方面的注意事项,则从生产日期起,在此期限内产品不会向外界泄漏有害、有毒物质或元素和发生化学变化,不会对环境造成严重污染或对人身、财产造成影响。另外,此标识中的期限不同于产品质量与功能的保证期,望周知。]

The Marking of Environmental Protection Use Period is formulated according to the stipulations in the "Management Methods for Controlling Pollution by Electronic Information Products" and "Marking for Control of Pollution Caused by Electronic Information Products", and applies to the electronic information products sold in the People's Republic of China.

The number in the middle of the logo means the unit of years for the actual environmental protection use period for this product. Within the indicated period from the date of manufacture, the toxic or hazardous substances or elements contained in the electronic information products will not leak or mutate under normal operating conditions so that the use of this electronic information products will not result in any severe environmental pollution, any bodily injury or any damage to assets.

In addition, note that a time limit in this marking is different from a guarantee period for quality and functions of this product.

製品中の有毒有害物質または元素の名称および含有量 [产品中有毒有害物质或元素的名称及含量]
Names and Contents of Toxic or Hazardous Substances or Elements

| 部品名称 [部件名称] Part Name | 有毒有害物質または元素 [有毒有害物质或元素] Toxic or Hazardous Substances and Elements | | | | | |
|---------------------------------------|---|------------------------------|---------------------------------|--|---|---|
| | 鉛 [鉛] Lead (Pb) | 水銀 [汞] Mercury (Hg) | カドミウム [鎘] Cadmium (Cd) | 六価クロム [六价铬] Hexavalent Chromium (Cr(VI)) | ポリ臭化ビフェニル [多溴联苯] Polybrominated biphenyls (PBB) | ポリ臭化ジフェニルエーテル [多溴二苯醚] Polybrominated diphenyl ethers (PBDE) |
| Pump Unit | X | O | O | X | O | O |
| Power Supply (EI-Dxx03M/MT series) | X | O | X | X | O | O |
| Cables | X | O | X | X | O | O |

O: 当該部材に使用されているすべての均質材料中における当該有毒有害物質の含有量がいずれも SJ/T11363-2006 標準に規定する限度量の要求以下であることを示す。

[表示该有毒有害物质在该部件所有均质材料中的含量均在SJ/T 11363-2006 标准规定的限量要求以下。]

Indicates that this toxic or hazardous substance contained in all of the homogeneous materials used for this part is below the limit requirement in SJ/T11363-2006.

X: 当該部材に使用されているある均質材料中における当該有毒有害物質の含有量が SJ/T11363-2006 標準に規定する限度量の要求を上回ることを示す。

[表示该有毒有害物质至少在该部件的某一均质材料中的含量超出SJ/T 11363-2006 标准规定的限量要求。]

Indicates that this toxic or hazardous substance contained in at least one of the homogeneous materials used for this part is above the limit requirement in SJ/T11363-2006.

SHIMADZU CORPORATION

SHIMADZU CORPORATION. International Marketing Division

3 Kanda-Nishikicho 1-chome, Chiyoda-ku, Tokyo 101-8448, Japan
Phone:81(3)3219-5641 Fax:81(3)3219-5710

SHIMADZU PRECISION INSTRUMENTS, INC.

SEMICONDUCTOR EQUIPMENT USA COMPANY

2340-C Walsh Avenue, Santa Clara, CA95051, U.S.A.
Phone:1(408)566-0960 Fax:1(408)566-0961 <http://www.shimadzuvacuum.com/>

KRATOS ANALYTICAL LTD.

Wharfside, Trafford Wharf Road, Manchester M17 1GP U.K.
Phone:44(161)888-4400 Fax:44(161)888-4402 E-mail:vacuum@kratos.co.uk

SHIMADZU (ASIA PACIFIC) PTE LTD.

16 Science Park Drive #01-01 The Pasteur Singapore Science Park, Singapore 118227,
Republic of Singapore
Phone:65-6778-6280 Fax:65-6779-2935

SHIMADZU INTERNATIONAL TRADING (SHANGHAI) Co., LTD.

24th Floor, Shanghai Xin-Huafan Building No.755 Huaihai Zhong Lu, Shanghai 200020
Phone:86(21)6472-8442 Fax:86(21)6472-8648



 SHIMADZU