

DTT3500 Digital

Information in this document is subject to change without notice and does not represent a commitment on the part of Creative Technology Ltd. No part of this manual may be reproduced or transmitted in any form or by any means, electronic or mechanical, including photocopying and recording, for any purpose without the written permission of Creative Technology Ltd. The software described in this document is furnished under a license agreement and may be used or copied only in accordance with the terms of the license agreement. It is against the law to copy the software on any other medium except as specifically allowed in the license agreement. The licensee may make one copy of the software for backup purposes.

Copyright © 2000 by Creative Technology Ltd. All rights reserved.

Version 1.0
August 2000

© 2000 Cambridge SoundWorks, Inc. All rights reserved. Cambridge SoundWorks is a registered trademark, and DeskTop Theatre is a trademark of Cambridge SoundWorks, Inc., Newton, MA. The Creative logo, Sound Blaster and the Sound Blaster logo are registered trademarks, and EAX, the EAX logo, PC-DVD, CMSS, Live! and Creative Multi Speaker Surround are trademarks of Creative Technology, Ltd in the United States and/or other countries. NOMAD is a registered trademark of Aonix and is used by Creative Technology and/or its affiliates under license. The DTT3500 Digital's Dolby Digital decoder/amplifier is manufactured under license by Dolby Laboratories. Dolby, Dolby Digital, Pro Logic, AC-3 and the Double D symbol are trademarks of Dolby Laboratories, Inc. Confidential unpublished works. Copyright 1992-1997 Dolby Laboratories. All rights reserved. Sony is a registered trademark and PlayStation 2 is a trademark of Sony Computer Entertainment Inc. Microsoft and DirectSound are registered trademarks of Microsoft Inc. All other brand and product names are trademarks or registered trademarks of their respective holders.

All specifications are subject to change without prior notice. Actual contents may differ slightly from those pictured.

Safety & Regulatory Information

The following sections contain notices for various countries:

CAUTION: This device is intended to be installed by the user in a CSA/TUV/UL certified/listed IBM AT or compatible personal computers in the manufacturer's defined operator access area. Check the equipment operating/installation manual and/or with the equipment manufacturer to verify/confirm if your equipment is suitable for user-installed application cards.

Modifications

Any changes or modifications not expressly approved by the grantee of this device could void the user's authority to operate the device.

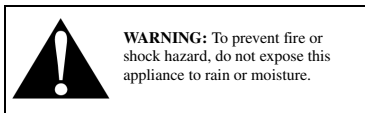

Compliance

This product conforms to the following Council Directive:

- Directive 89/336/EEC, 92/31/EEC (EMC) 72/23/EEC (LVD)

Important Notice

The serial number for the *DIT3500 Digital* is located on the subwoofer. Please write this number down and keep it in a secure area. This is for your security.

IMPORTANT SAFETY INSTRUCTIONS

READ INSTRUCTIONS - All safety and operating instructions should be read before the *DTT3500 Digital* amplified subwoofer/satellite system is operated.

RETAIN INSTRUCTIONS - The safety and operating instructions should be retained for future reference.

HEED WARNINGS - All warnings on the subwoofer and in the operating instructions should be adhered to.

FOLLOW INSTRUCTIONS - All operating and use instructions should be followed.

CLEANING - Unplug the subwoofer from the wall outlet or other power source before cleaning. Do not use liquid cleaners or aerosol cleaners. Use a damp cloth for cleaning.

ATTACHMENTS - Do not use attachments not recommended by Cambridge SoundWorks as they may cause hazards.

WATER AND MOISTURE - Do not use the subwoofer near water—for example, near a bath tub, wash bowl, kitchen sink, or laundry tub; in a wet basement; or near a swimming pool; and the like.

ACCESSORIES - Do not place the *DTT3500 Digital* system on an unstable cart, stand, tripod, bracket, or table. The subwoofer or satellites may fall, causing serious injury to a child or adult, and serious damage to the product. Use only with a cart, stand, tripod, bracket, or table recommended by Cambridge SoundWorks, or sold with the product. Any mounting of the satellites or subwoofer should follow the manufacturer's instructions, and should use a mounting accessory recommended by Cambridge SoundWorks.

VENTILATION - Slots and openings in the cabinet are provided for ventilation, to ensure reliable operation of the subwoofer and to prevent it from overheating; and these openings must not be blocked or covered. The openings should never be blocked by placing the product on a bed, sofa, rug, or other similar surface. The subwoofer should not be placed in a built-in installation such as a bookcase or rack unless proper ventilation is provided or Cambridge SoundWorks' instructions have been adhered to.

HEAT - The subwoofer should be situated away from heat sources such as radiators, heat registers, stoves, and other products (including amplifiers) that produce heat.

POWER SOURCES - The subwoofer should be operated only from the type of power source indicated on the marking label. If you are not sure of the type of power supply to your home, consult your product dealer or local power company. For products intended to operate from battery power or other sources, refer to the operating instructions.

POLARIZATION - The subwoofer may be equipped with a polarized alternating-current line plug (a plug having one blade wider than the other). This plug will fit into the power outlet only one way. This is a safety feature. If you are unable to insert the plug fully into the outlet, try reversing the plug. If the plug should still fail to fit, contact your electrician to replace your obsolete outlet. Do not defeat the safety purpose of the polarized plug.

POWER-CORD PROTECTION - Power-supply cords should be routed so that they are not likely to be walked on or pinched by items placed upon or against them, paying particular attention to cords at plugs, convenience receptacles, and the point where they exit from the subwoofer.

LIGHTNING - For added protection for the *DTT3500 Digital* system during a lightning storm, or when it is left unattended and unused for long periods of time, unplug it from the wall outlet. This will prevent damage to the subwoofer due to lightning and power-line surges.

OVERLOADING - Do not overload wall outlets, extension cords, or integral convenience receptacles as this can result in a risk of fire or electric shock.

OBJECT AND LIQUID ENTRY - Never push objects of any kind into the subwoofer through openings as they may touch dangerous voltage points or short out parts that could result in a fire or electric shock. Never spill liquid of any kind on the subwoofer.

SERVICING - Do not attempt to service the subwoofer yourself as opening or removing covers may expose you to dangerous voltage or other hazards. Refer all servicing to qualified service personnel.

DAMAGE REQUIRING SERVICE - Unplug the subwoofer from the wall outlet or other power source and refer servicing to qualified service personnel under the following conditions:

a) When the power-supply cord or plug is damaged.

b) If liquid has been spilled, or object have fallen into the subwoofer.

c) If the subwoofer has been exposed to rain or water.

d) If the subwoofer does not operate normally by following the operating instructions; or exhibits a distinct change in performance.

e) If the product has been dropped or damaged in any way.

REPLACEMENT PARTS - When replacement parts are required, be sure the service technician has used replacement parts specified by Cambridge SoundWorks or have the same characteristics as the original part. Unauthorized substitutions may result in fire, electric shock, or other hazards.

SAFETY CHECK - Upon completion of any service or repairs to the *DTT3500 Digital* system, ask the service technician to perform safety checks to determine that the *DTT3500 Digital* system is in proper operating condition.

WALL OR CEILING MOUNTING - The *DTT3500 Digital* satellites should be mounted to a wall or ceiling only as recommended by Cambridge SoundWorks.

DTT3500 Digital



Contents

Introduction.....	5
Inventory.....	6
Recommended Signal Sources.....	6
Installation Sequence.....	7
Speaker System Connections.....	7
Speaker System Connection Diagram.....	8
Signal Source Connections.....	9
Signal Source Connection Diagram.....	10
Speaker Cable and Stand Installation.....	11
Mounting Speakers.....	12
Speaker Placement.....	13
Decoder Amplifier Placement.....	16
Decoder Amplifier Functions.....	17
Surround Reference.....	19
Multiple Connections.....	21
Applications Guide.....	22
Playback Levels.....	25
Specifications.....	25
EAX.....	25
Technical Support.....	27
Limited Warranty.....	30

Introduction

Thank you for purchasing *DTT3500 Digital* by Cambridge SoundWorks. *DTT3500 Digital* lets you experience the full potential of Dolby® Digital multichannel sound from your DVD player or game console, with a dynamic output that rivals a component home theater system. It processes both Dolby Digital and Dolby Surround program material.

DTT3500 Digital includes an OPTICAL connection to enhance the connectivity and usability to any devices with OPTICAL output.

DTT3500 Digital also includes a DIGITAL DIN input which supports discrete 5.1-channel output.

DTT3500 Digital offers up to 6-channel discrete audio support for Microsoft® DirectSound® 3D and its other derivatives. In some of today's best CD-based action games, *DTT3500 Digital* can decode the Dolby Digital cut-scenes while offering enveloping positional multichannel audio. It's ready for the new era of DVD-based games.

Also included is Creative Multi Speaker Surround (CMSS), which lets you hear all of your favorite stereo program material with a new and exciting three-dimensional quality.

DTT3500 Digital comes equipped with an I.R. Remote Control, providing wireless control over a variety of audio functions.

The Memory Retention feature of the *DTT3500 Digital* system remembers the last used user settings in standby mode.

Inventory

Examine each unit carefully for shipping damage. If there is any, do not install or use the system. For advice, call the store where you made your purchase or call Creative Technology Ltd. technical support. Save the shipping carton and inserts in case you have to transport the system later. All of the items shown in the illustration below should be included with your system. If anything is missing, notify the retailer.



Subwoofer



Decoder Amplifier



15V 4A DC Power Adapter



Support Extends (18)



Monitor Stand (for Center Speaker)



Center Speaker



Remote Control



Feet (6)



Supports (6)



Desktop Stand (for Center Speaker)



Satellites (4)



"AA"- Size Battery (2)



Frames (2)



Holder/Cap (2)



Desktop Stand (4) (for Satellites)



Screw (for Center Speaker Stands)



Strips of Rubber Feet (2)



Screws and Plastic Anchors (2)



Identification Labels

Recommended Signal Sources

The *DTT3500 Digital* supports many signal source inputs, both analog and digital. For example:

1. DVD players with Dolby Digital (AC-3) optical outputs. DVD players with coaxial outputs (for example, the Creative labs PC-DVD Encore) may also be used.
2. Sound cards that support DirectSound®3D sound processing,

- including front and rear 2-channel minijack line outputs (like Sound Blaster Live! series or Creative Labs Sound Blaster PCI series). Sound Blaster Live! owners should utilize the exclusive Digital DIN connection to hear the clearest digital audio available.
3. Conventional 2-channel sound cards such as Sound Blaster 16 or the

Sound Blaster AWE series can also be used with the *DTT3500 Digital*.

4. Game consoles like the PlayStation 2 using the Optical or Analog Line In connections.

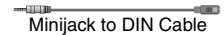

Minijack to DIN Cable



3m Speaker Cable



SPDIF Cable (RCA to RCA)



5m Speaker Cable (2)



Stereo to Dual RCA Cable



Optical Cable



Tandem Audio Cable



Dual Female-to-Female RCA Adapter



SPDIF DIN Cable

Installation Sequence

1. Read all of the instructions before installing the speaker system.
2. Attach the provided stand to the Decoder Amplifier if you wish to place the unit vertically. For more details see “Decoder Amplifier Placement” on page 16.
3. Connect the Satellites, Center Speaker, and Subwoofer to the Decoder Amplifier.
4. Connect the Dolby Digital output of your digital program source to the coaxial and/or optical Dolby Digital input of the Decoder Amplifier.
5. Connect your normal audio signal sources via the Analog Line In inputs. An owner of a Sound Blaster Live! sound card with a Digital DIN output should use the supplied cable to connect it to the Digital DIN input instead.
6. Using the placement instructions as a guide, position the Satellites, the Center Speaker and Subwoofer. Install the Desktop Stands and Floor Stands as appropriate. If you wish to substitute a powered subwoofer for the subwoofer that comes with *DTT3500 Digital*, read “Substituting a powered subwoofer” on page 15.
7. Connect the Power Adapter to the Decoder Amplifier.
8. Turn on the power. Use the TEST function on the Remote Control to position and balance the speakers.
9. You may wish to experiment with speaker placement briefly before concealing the connecting cables and making the installation more permanent.
10. The unit is ready for you to enjoy.

Speaker System Connections

Speaker Connections

Insert one satellite’s plug into the corresponding Speaker Output on the Decoder Amplifier. Repeat this process for the remaining satellites, center speaker and subwoofer. For more details see “Speaker Cable and Stand Installation” on page 11.

If substituting a powered subwoofer, connect it to the Subwoofer Line Out. For more details see “Substituting a powered subwoofer” on page 15.

Power Adapter Connections

Insert the small DC connector into the **15V DC IN** jack on the back of the Decoder Amplifier. Insert the Power Adapter’s AC plug into an appropriate receptacle.

Note: Set the Decoder Amplifier to standby mode before unplugging or turning off the power supply.

Speaker System Connection Diagram

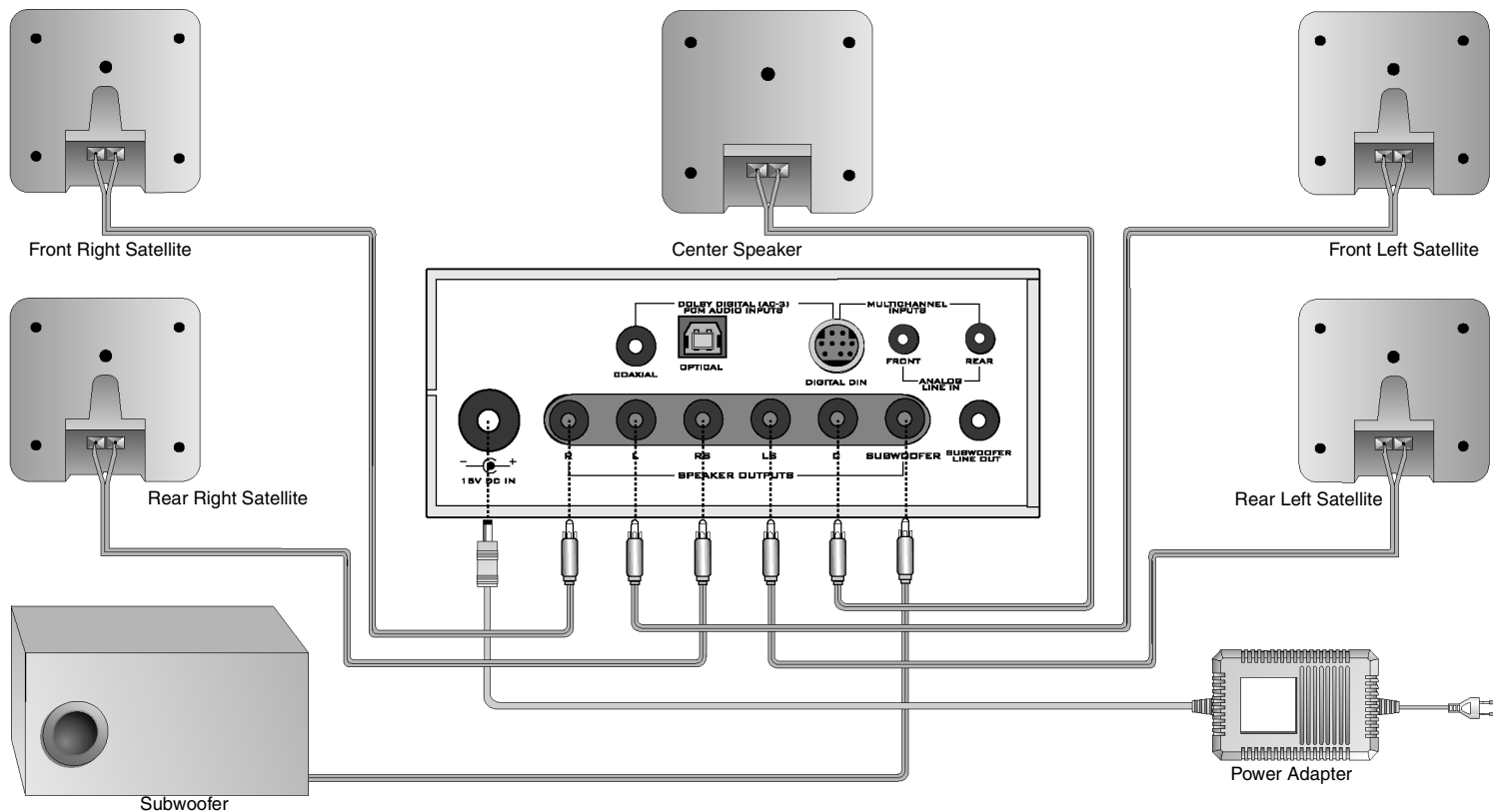

Signal Source Connections

Dolby Digital source

Connect the Dolby Digital/SPDIF output of your signal source to the Decoder Amplifier's Dolby Digital (AC-3) / PCM Audio Inputs

COAXIAL or **OPTICAL** jack using the **SPDIF Cable (RCA to RCA)** or the **Optical Cable**.

Game consoles

Connect the optical output of the game console (e.g. PlayStation 2) to the **OPTICAL** input with the **Optical Cable**.

Use the **Stereo to Dual RCA Cable** and the **Dual Female-to-Female RCA Adapter** to connect to the game console's RCA output through the multiple A/V plug. Then connect the miniplug end of the **Stereo to Dual RCA Cable** to the **FRONT** jack of the Decoder Amplifier.

For devices with optical output

Connect the optical output of these devices (e.g. CD or MD players) to the **OPTICAL** input with the **Optical Cable**.

For Sound Blaster Live! sound cards with Digital Out output

Connect the sound card's Digital Out output to the **Digital DIN** input with the **Minijack to DIN Cable** and the **SPDIF DIN Cable**.

For DIN Bracket bundled with Live! Drive IR

Connect its Digital DIN output to the **DIGITAL DIN** input with the **SPDIF DIN Cable**.

For all other sound cards

Use the **Tandem Audio Cable**. Connect the lime-green stereo miniplugs to the Line Out minijack output of your sound card and to the **FRONT** minijack input of the

Decoder Amplifier. Connect the black stereo miniplugs to the Rear Out minijack output of your sound card (if present) and to the **Rear** minijack input of the Decoder Amplifier.

Signal Source Connection Diagram

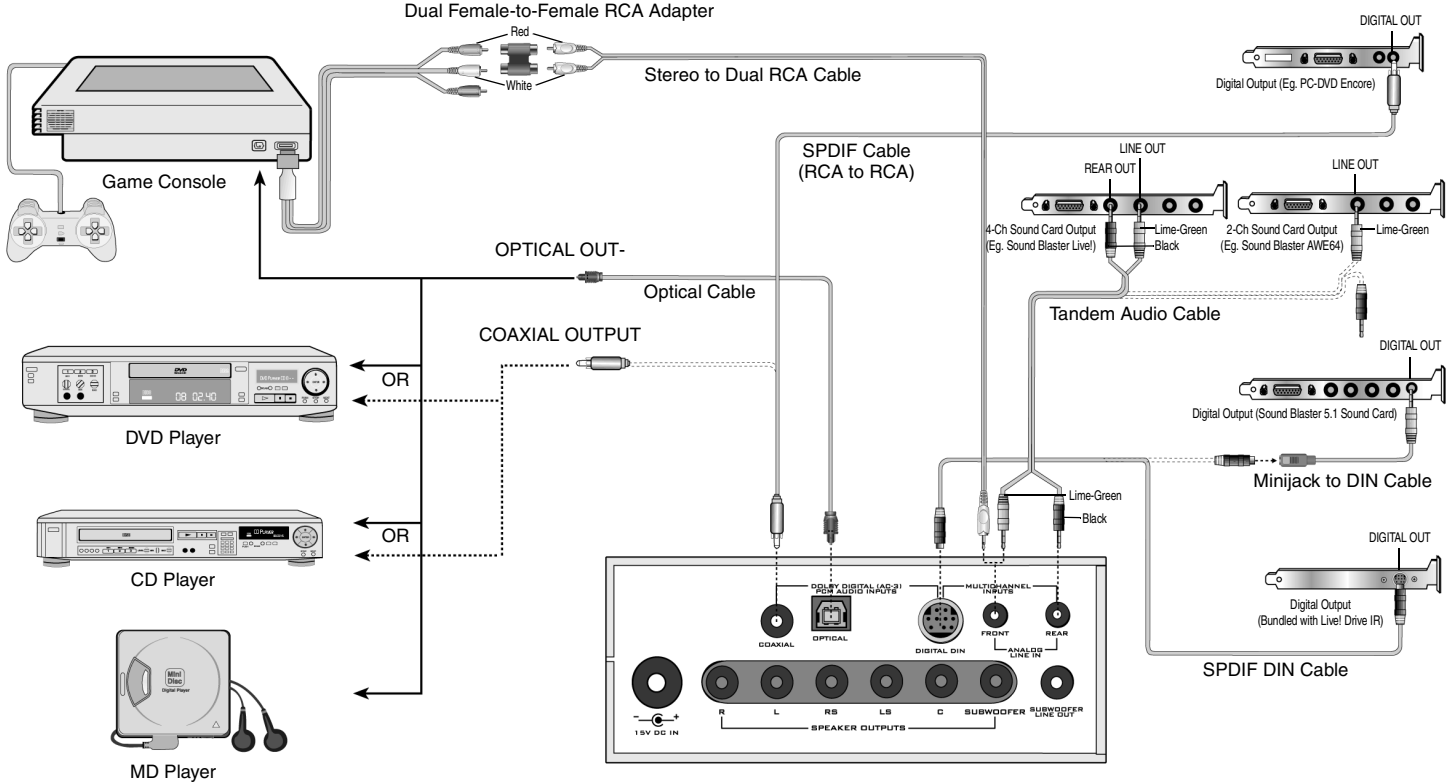

Speaker Cable and Stand Installation

Speaker Cable Installation

Typically, the 3 meter (5 feet) Speaker Cables will connect the front Satellites and the Center Speaker to the Decoder Amplifier and the 5 meter (9 feet) Speaker Cables will connect the rear Satellites to the Decoder Amplifier. A panel of twelve self-adhesive labels is provided to identify each Satellite and Subwoofer and the opposite end of the cable connected to a Satellite and Subwoofer.

1. Identify a 3 meter Speaker Cable. Most often, a Satellite will be used with a Desktop Stand. In this case, thread the bare cable end of a 3 meter Speaker Cable through the hole in the Desktop Stand. Connect this end to a Satellite (as shown in **Diagram A**). Carefully

- insert the Desktop Stand's attachment arm into the socket in the back of the Satellite, taking up any slack in the cable as required.
- To use this Satellite in the front left position, remove the backing from the small, round "L" label and apply it to the back of the Satellite (see **Diagram A**).
- Remove the backing from the remaining, longer "L" label and wrap it around the opposite end of the Speaker Cable near the RCA plug.
- Place the Satellite in the front left position.
- Repeat this process using another 3 meter Speaker Cable for the front right Satellite, using the "R" labels.
- Connect another 3 meter Speaker Cable to the Center Speaker. Use the "C" (center) labels. For details on attaching Center Speaker stands, see "Center Speaker Stand Installation" on page 12.
- Use the RS and LS labels (right and left surround) and 5 meter Speaker Cables for the rear Satellites.

- If you wish to use the Floor Stands with the rear Satellites, assemble the stand according to the **Floor Stand Assembly** leaflet.
- Use the last 3 meter Speaker Cable and the "SUB" labels for the Subwoofer.

Speaker Cable Usage

To connect the Speaker Cable to each speaker, press one of the spring-loaded tabs to expose the connection hole.

Insert the bare end of the cable into the exposed hole, then release the tab to lock the cable in place. Connect cables with red bands to red tab connectors, and unmarked wires to black tab connectors.

Notes: Matching red cables to red tabs and unmarked cables to black tabs insures the speakers all play "in phase". "Out-of-phase" connections will do no electrical harm, but the overall sound quality will be greatly reduced. You can substitute regular 18 gauge speaker cable to create longer cables, if needed. The 5 meter cables may also be used for the front satellites if required.

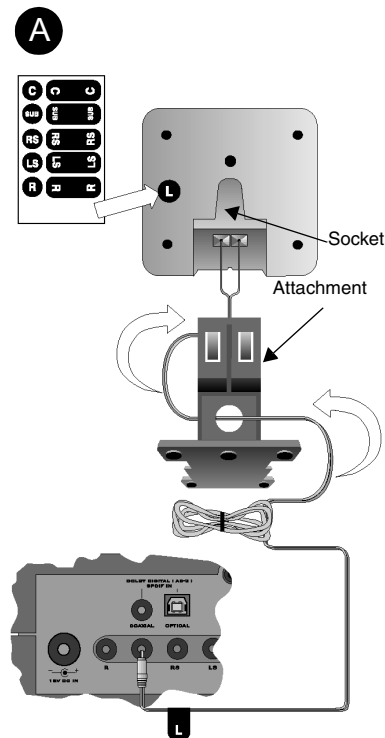

Center Speaker Stand Installation

Unlike the Desktop Stand (for Satellites), the stands for the Center Speaker are of the screw-in type.

1. Align the Attachment Arm to the Center Speaker (see **Diagram B**).
2. Use the screw provided to connect the Attachment Arm to the Center Speaker.

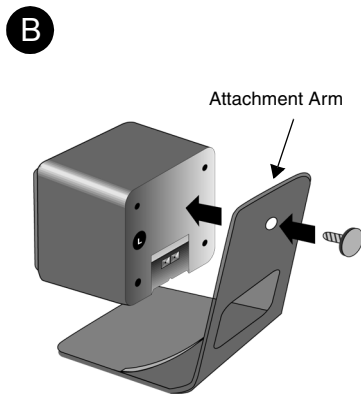

Mounting Speakers

Screw Mounting

Mounting the rear satellites on side walls will give you superior surround effects.

For a secure installation, mount the rear satellites only on walls that are structurally sound.

1. Place the following near you: rear satellites, screws, plastic anchors and rubber pads (supplied). You will also need a drill and hammer.
2. Mark the wall where each rear satellite screw will be. Position the speakers behind you and slightly above ear level.
3. Drill a hole about 2 cm (1 inch) deep into each wall. Tap a plastic anchor into the hole until it is flush with the wall (see **Diagram C**).
4. Screw a M5 x 25 mm screw into each anchor, leaving about 0.5 cm (1/4 inch) of the screw protruding.
5. Apply four rubber pads on the corners at the back of each rear

satellite. The rubber pads will cushion the satellites from any vibration and help keep them in position.

6. Slip the keyhole of each rear satellite onto a protruding screw to complete the installation.

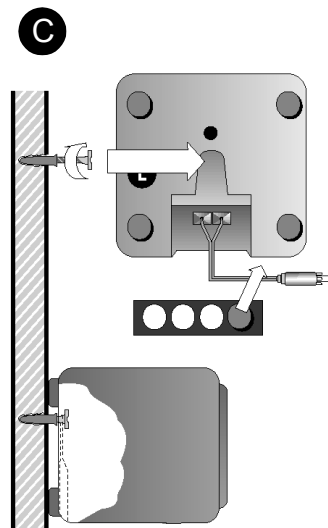

Speaker Placement

The Front Satellites

The left front and right front Satellites play stereo music, the off-screen sounds of video playback and the front channels of 4-channel games.

These Satellites should be placed to the sides of your T.V. or monitor. Try to form an equilateral triangle with your head and the satellites (see **Diagram D**). Be sure to have a clear line of sight from your listening position to these Satellites.

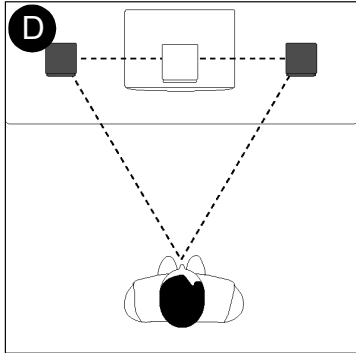

Install the Satellite's Desktop Stands when using them on the desktop, see "Speaker Cable and Stand Installation" on page 11.

The Center Speaker

The Center Speaker provides the on-screen effects and dialog in Dolby Digital, Dolby Surround or Creative Multi Speaker Surround modes. It should be placed as close to the center of your T.V. or monitor as possible.

There are many mounting possibilities. The Center Speaker can be placed on top of the T.V or monitor by using the provided Monitor Stand. It directs the sound

down towards the listener (see **Diagram E**).

Use the Center Speaker Desktop Stand to position a Center Speaker in front of the T.V. or monitor. It directs the sound up towards the listener (see **Diagram F**).

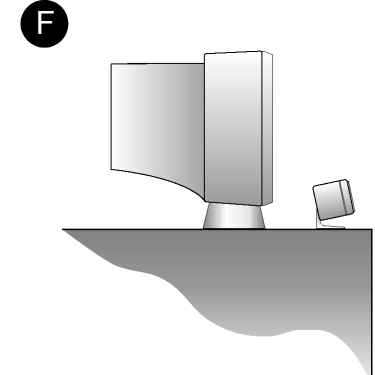
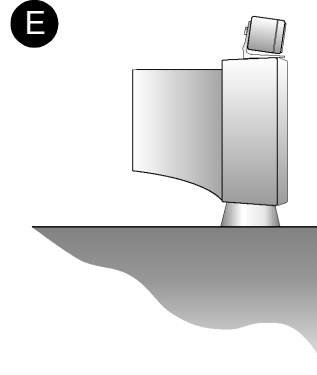

The Rear Satellites

The rear Satellites provide the surround effects in Dolby Digital, Dolby Surround or Creative Multi Speaker Surround modes. They also produce the discrete rear sounds of 4-channel sound cards.

5 meters (16 feet) of cable is provided with the two remaining Satellites for more flexibility in rear channel placement. The rear Satellites may be placed in any convenient sites alongside the listener, including sites slightly forward of the listening location. The rear Satellites do not have to be at

exactly the same height as the front Satellites.

If you have side walls close to your listening position, excellent placement for the rear Satellites is slightly behind your listening position, slightly above ear level (see **Diagram G**). The Satellites may be hung on the wall using the Screw and Wall Anchors provided, see “Mounting Speakers” on page 12.

Any rear Satellite placement to the left and right side of the listening position will also provide strong directional and surround effects.

The rear Satellites may be installed on their convenient Floor Stands. The stands should be positioned to the left and right of your listening position (see **Diagram H**).

Larger T.V. consoles or desktops can accommodate both front and surround pairs of Satellites. Try the extreme corners of a console or desk using the Desktop Stands (see **Diagram I**).

After you have positioned the rear Satellites, use the **TEST** function on the Remote Control to make sure each speaker can be heard clearly.

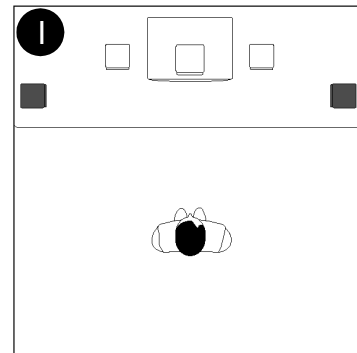
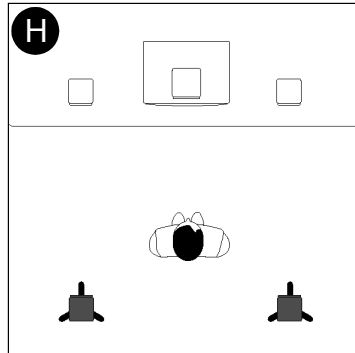
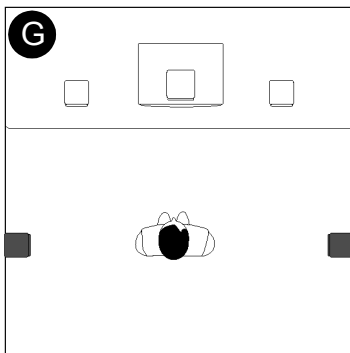

The Subwoofer

The Subwoofer's optimum position is on the floor against the wall. The closer the Subwoofer is to a corner, the stronger the maximum bass output. We strongly recommend placing the Subwoofer on the floor (see **Diagram J**). Leave at least 5 cm (2 inches) of space between the Subwoofer face and a wall. Position the Subwoofer so that its connection panel is facing a wall, shielded from inadvertent contact. The Subwoofer is not magnetically shielded, so position it at least 46 cm (18 inches) away from the T.V. or computer monitor.

Substituting a powered subwoofer

You may substitute a powered subwoofer for the subwoofer that comes with the *DTT3500 Digital*. Connect its line level input (typically an RCA jack) to the dedicated Subwoofer Line Out on the back of the Decoder Amplifier, using a shielded audio cable with RCA plugs on each end. Refer to the powered subwoofer's User Manual for adjustment procedures.

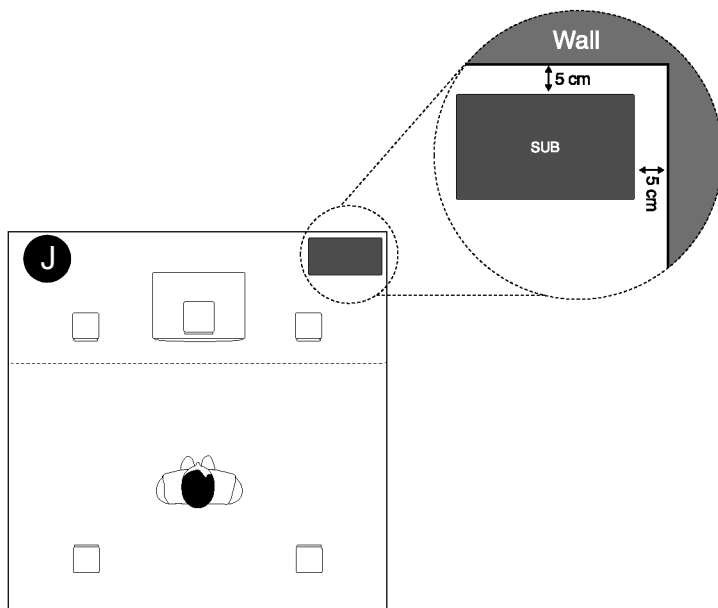

Decoder Amplifier Placement

The Decoder Amplifier can be placed on the desktop, a shelf or any site that makes the controls convenient.

The Power Adapter cord must be able to reach from the Decoder Amplifier back panel to your AC power receptacle.

Place the Decoder Amplifier on a hard, flat surface.

There are ventilation slots on the Decoder Amplifier's enclosure. Do not block these ventilation slots by placing materials over them.

Model Variations

There are two models of the Decoder Amplifier.

If you have purchased the horizontal version please ignore the following sections. Other than the changeable face plate feature, all functions remain the same.

The changeable face plate version is supplied with mylar sheets which enable you to choose a different design or orientation (horizontal or vertical).

Decoder Amplifier Stand

If placing the unit vertically, attach the provided stand to the base of the Decoder Amplifier (see **Diagram K**).

Face Plate Installation

The face of the front panel may be changed to reflect a different design or orientation. Remove the clear plastic cover and replace the underlying mylar sheet with another of your choice, (see **Diagram K**). Replace the cover.

Horizontal Placement

Place the Decoder Amplifier horizontally if there is adequate desktop space, (see **Diagram L**).

Vertical Placement

If your desktop space is limited you may choose to place the Decoder Amplifier vertically, (see **Diagram M**).

L

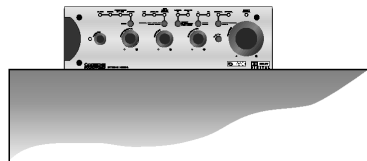

M

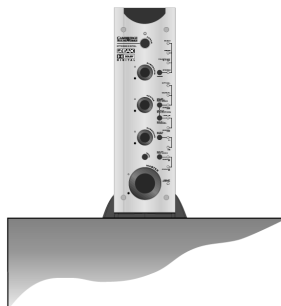

K

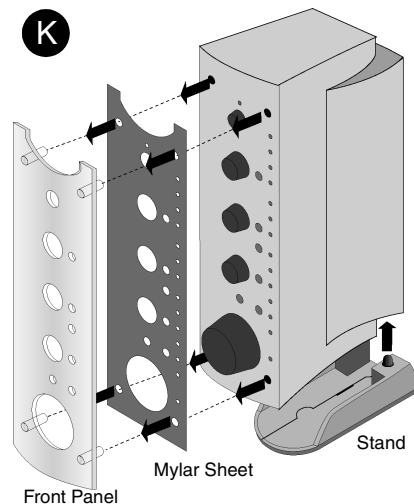

Decoder Amplifier Functions

The Standby LED lights up when the Power Adapter is connected to the mains. Press the Power button to turn on the Decoder Amplifier.

The CMSS Music LED will remain illuminated after initial start-up. The last used CMSS mode's light will illuminate for subsequent start-ups from system standby mode.

The Optical LED also lights up after initial start-up. The last used Dolby Digital/PCM Audio input's light will illuminate for subsequent start-ups from system standby mode.

The Digital DIN or Line In LED lights up, depending on whether Digital DIN or Analog Line In is connected. The Digital DIN LED will blink if a PC connected to the Decoder Amplifier is off but a Digital DIN input is connected. Turning on your PC stops the LED's blinking.

The indicator light for Dolby Digital will illuminate automatically if a Dolby Digital program is playing. That is, when a Dolby Digital signal passes through the

Decoder's processor via the Optical, Coaxial or Digital DIN (Dolby Digital/PCM Audio) inputs.

- POWER:** Sets the system to "On" or standby. When set to "On", the Standby LED above the power button turns off.
- SUBWOOFER, CENTER AND SURROUND:** These controls adjust the level of the indicated channels. Their output level should be balanced with the fixed output level of the Left and Right front Satellites.
- MASTER:** Adjusts the volume of the entire system. The Master volume knob is servo controlled via the Remote Control.
- CMSS:** CMSS (Creative Multi Speaker Surround) processes analog program material. Repeated presses of this button step through four different operation modes. **MOVIE:** Creates a 5.1 speaker soundfield appropriate for movie or game enjoyment from an analog sound source.

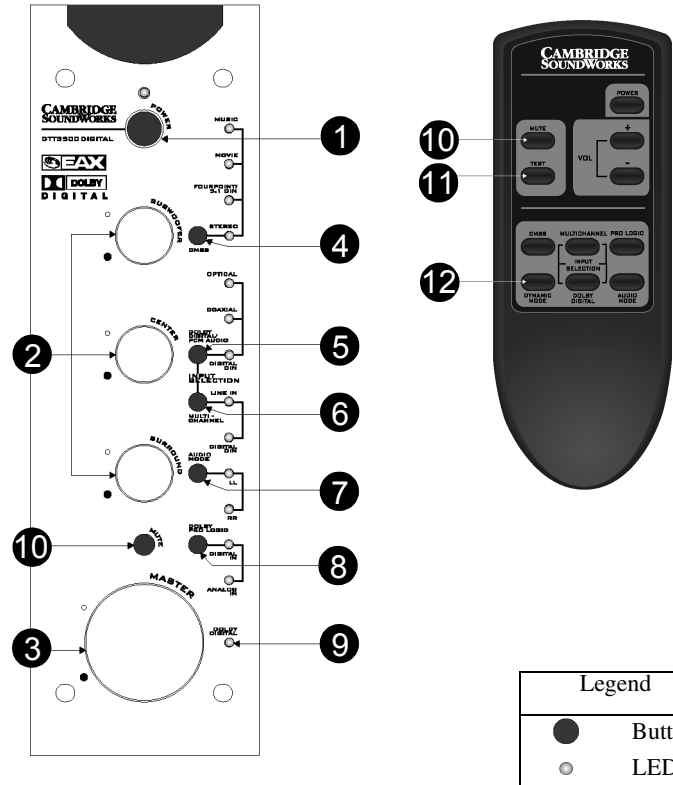

MUSIC: Creates a 5.1 speaker soundfield appropriate for music from any analog sound source.

FOURPOINT/5.1 DIN: Use this mode for DVD games having Dolby Digital soundtracks with EAX or Microsoft DirectSound3D for real-time positioning of sound effects. Typically a Dolby Digital 5.1-channel + analog signal source.

If a signal source is connected to the Analog Line In minijacks, 4.1-channel output is produced.

If the signal source is connected to the Digital DIN input, up to 5.1-channel output is produced. Typically when using a Sound Blaster Live! 5.1 sound card or the DIN bracket bundled with Live! Drive IR. For more details, see “Signal Source Connection Diagram” on page 10.

The DIN LED blinks if no signal or an invalid audio signal like an AC-3 signal is detected. In the case of an AC-3 signal, select Digital DIN at the Dolby Digital/PCM Audio input selection.

STEREO: Use this mode when you want to hear just stereo effects or the stereo Dolby Digital downmix of a DVD. The Dolby Surround Pro Logic processor is disabled in this mode.

5. **DOLBY DIGITAL /PCM AUDIO:** Use this button to select the signal source input. Repeated presses of the button cycles between Optical, Coaxial, Digital DIN and Off.
6. **MULTI-CHANNEL:** Use this button to select the signal source input. Repeated presses of the button cycle between Line In, Digital DIN and Off.
7. **AUDIO MODE:** Use this button to play just the left or right channels of a stereo digital signal (PCM from an audio CD, a Video CD or a stereo signal from a DVD). Use this when, for example, a Video CD has different languages on the left and right channels.
Repeated presses of the button select which channel is fed to both the Left and Right front speakers.

LL-Left channel program is directed to both Left and Right front speakers.

RR-Right channel program is directed to both Left and Right front speakers. See “Audio Mode Selection” on page 20 for further information about this feature.

8. **DOLBY PRO LOGIC:** This button cycles from Dolby Pro Logic processing of the digital input to Dolby Pro Logic processing of the analog input, then to no Pro Logic processing.
9. **DOLBY DIGITAL:** This light turns on whenever a Dolby Digital signal is detected at the SPDIF input of the *DTT3500 Digital*. For Dolby Digital 5.1 sound reproduction, make sure only this light is illuminated.
10. **MUTE:** Mutes all output from the *DTT3500 Digital*. Press the button once to mute. The blue LED on the Master volume knob blinks and all functions are operable except speaker test. Press a second time to restore audio output. After being muted for more than thirty minutes, the

Decoder Amplifier goes to standby mode and the Standby LED lights up.

11. **TEST:** Press this button to start the “test sound” generator. Use this test sound to position all the speakers and to balance their relative output.

The test sound moves in sequence from the left Satellite, the Center Speaker, the right Satellite, then to the rear right Satellite, rear left Satellite and the subwoofer. All indicator lights will blink on and off while the test sound generator is in operation.

The test sound will operate for three complete cycles and then stop. You can terminate the sound at any point by pressing the Test button again.

First use the test sound to verify that each speaker is operating.

Then make sure the speakers are positioned so that the test sound can be clearly heard.

Finally, adjust the front panel level controls for the Center, Subwoofer and rear Satellites. Adjust each control so its speaker achieves a

balanced output level with the left and right satellites (which provide a fixed “reference” output level).

All functions except for the level controls are disabled while the test sound is running.

The speaker level controls operate at all times. If desired, you may adjust these controls during program material to fine-tune the balance.

(This function is only available on the Remote Control)

Note: Volume levels during the test sequence are lower than during normal operation.

- DYNAMIC MODE:** Press this button to experience the full dynamic range of Dolby Digital programs. The LEDs on the upper half of the Decoder Amplifier light up momentarily. The program source will sound louder in Dynamic Mode. If you press this button again, the default mode (compressed) resumes. The LEDs on the lower half of the Decoder Amplifier light up momentarily. (This function is only available on the Remote Control)

Surround Reference

Dolby Digital

Dolby Digital (earlier called AC-3) delivers five discreet full-range channels (left front, center, right front, left surround and right surround) plus a separate Low Frequency Effects (LFE) channel.

Many soundtracks on the latest generation laser discs, DVDs and High Definition Television (HDTV), are encoded with Dolby Digital technology.

When a 5.1-channel Dolby Digital program source is playing, such as from a Creative PC-DVD player, DVD player or game console, the Dolby Digital indicator light will illuminate automatically.

Note: Not every section of a DVD will be 5.1-channel encoded. On many DVDs, only the main movie program will be available in 5.1-channel sound. Other supporting chapters (like a “Director’s Comment” section) may be in stereo or mono. These sections will not light the Dolby Digital indicator even

though the sound will be properly reproduced by the *DTT3500 Digital*.

Dolby Pro Logic

Dolby Surround is an earlier surround sound standard which is decoded with a Pro Logic processor in the *DTT3500 Digital*. The Pro Logic steering circuitry derives separate center and rear channels from encoded stereo program sources.

Pro Logic processing provides a convincing movie soundfield when the material is specifically encoded for Dolby Surround. Most older stereo movie soundtracks will only be encoded for Dolby Surround, even though the program source may be a DVD’s digital output. Most DVDs containing Dolby Surround program material will cause both the Dolby Digital and Dolby Pro Logic lights to illuminate. *DTT3500 Digital* will decode these digitally transferred Dolby Surround programs through the digital Pro Logic decoder automatically.

CD-ROMs and CDs with Dolby Surround encoding will feature the Dolby Surround logo at the beginning of the program or on the packaging.

Process these programs by selecting Analog In using the Dolby Pro Logic button for input through Analog Line In.

If using Digital DIN input, ensure that the Digital DIN on the Dolby Digital/PCM Audio input is selected. Then select Digital In using the Dolby Prologic button.

When Dolby Pro Logic is selected CMSS is turned off. To turn on CMSS again, turn off Dolby Pro Logic first.

Do not select a Pro Logic decoding mode if the program material is not encoded for Dolby Surround. Excessive center channel output will result, and most of the stereo effect will be lost. Use CMSS “Movie” or “Music” modes to upmix stereo programs to a realistic 5.1-channel sound field.

Creative Multi Speaker Surround (CMSS)

CMSS is a 2-channel to 5.1-channel sound processor similar in some aspects to a Dolby Surround Pro Logic processor.

The Music mode creates a convincing 5.1-channel surround soundfield with typical stereo sources, whether they are Dolby Surround-encoded or not. It works well with Dolby Pro Logic, WAVE, AVI and MIDI program material. In essence, CMSS Music mode puts you “on the stage” for the music’s performance, surrounding you with the performers.

In a similar manner, Movie mode provides the sonic impression of being front and center at a movie screening. Dialog and all normally centered sounds from a stereo program are heard through the center speaker. Use this mode whenever a music program has sounds you want to blend with on-screen action or dialog.

Unlike Pro Logic decoding, CMSS Music, Movie and FourPoint/5.1

DIN modes are appropriate for use with multi-coded sources such as DVD games. In some game titles, the movie sequences may be encoded in Dolby Surround but the game sequences may be in the WAV format. CMSS Movie mode supports 5.1-channel output for .WAV, .AVI, .MIDI and other audio software formats. Few, if any of these kinds of formats are Dolby Surround encoded.

The FourPoint/5.1 DIN mode passes the four discrete channel audio of 4-channel games direct to each satellite channel. It does not synthesize rear channel output, so stereo signal in this mode will play just through the front two speakers and subwoofer.

The **STEREO** mode plays the Left and Right Front speakers and the subwoofer. It also lets you hear the stereo downmix from any DVD.

The Dolby Pro Logic processor is disabled in this mode.

Audio Mode Selection

The stereo soundtracks of some movies on Video CDs (VCD format)

contain different languages. For example, a 2-channel soundtrack may contain Mandarin on the right channel and English on the left channel. The VCD program literature should indicate the presence of dual-language soundtracks. Similarly, some movies in the DVD format will contain dual-language soundtracks. *DTT3500 Digital* lets you select one of these languages and play it through both the Left and Right speakers.

If there is no indication of which channel is which, and you hear two different language soundtracks during stereo playback, select the “LL” and “RR” settings until you find the language soundtrack you want.

The Audio Mode selection feature can only be used with the PCM digital soundtrack of a Video CD or DVD with a dual soundtrack, not a DVD encoded with Dolby Digital 5.1 sound or Dolby Surround-encoded material. If you have an analog program with separate left and right channels (the analog output of a CD ROM, or the analog stereo

output of a “software” Video CD, for instance), you will have to use the balance control in your PC’s audio software to mute the undesired channel.

Multiple Connections

The *DTT3500 Digital* system has many configuration possibilities. Typically, the system can be connected to either a game console or a PC.

However, the *DTT3500 Digital* allows you to connect to both, forming a hybrid system.

Connecting to a Game Console and a PC

You can connect your game console and PC to the *DTT3500 Digital* system while sharing one monitor by following the instructions below.

Audio Connection:

1. Connect your game console's audio output to the Decoder Amplifier's Front minijack input with the provided Dual Female-to-Female RCA adapter.
2. Connect your PC's audio output to the Decoder Amplifier.

Video Connection:

1. Connect your game console's video output to a RF to VGA video converter box.

2. Connect your video converter's output to a VGA switch box.
3. Connect your PC's VGA output to the VGA switch box.
4. Connect the PC monitor's VGA input socket to the output of the VGA switch box.

After completing the above connections you will be able to choose the display output between your PC and game console by using the switch box.

To select the audio output, use the Dolby Digital/PCM Audio or Multi-channel input buttons on the Decoder Amplifier.

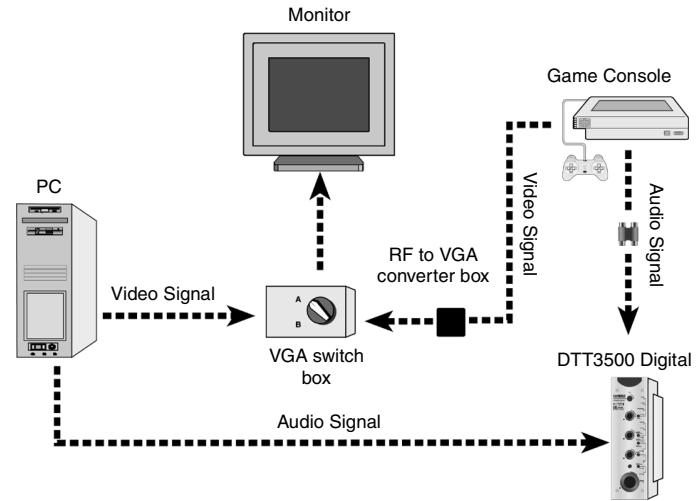

Applications Guide

Playing Games:

Playing Multi-format DVD Games

These games have Dolby Digital or Dolby Pro Logic movie clips mixed with the actual game sequence. These DVD games have a mix of Dolby Digital 5.1 sound (a digital signal at the SPDIF input) and soundcard wavetable output (a signal at the analog input).

PC-DVD Setup

For AC-3 signal source connected to COAXIAL input:

Select the COAXIAL input using the DOLBY DIGITAL/PCM AUDIO input selection button. The Dolby Digital or Dolby Pro Logic source signal will be automatically processed.

For multi-channel inputs (FRONT and REAR ANALOG LINE IN or DIGITAL DIN):

1. Select LINE IN or DIGITAL DIN input using the MULTI-CHANNEL button.

2. Select the FOURPOINT/5.1 DIN mode using the CMSS button.

For 2-channel sound cards:

1. Select LINE IN input using the MULTI-CHANNEL button.
2. Select MOVIE or MUSIC mode using the CMSS button.

Software DVD Player

For sound card's with analog output to FRONT and REAR ANALOG LINE IN or digital output to DIGITAL DIN:

Use the software DVD player to process all signals into multi-channel output.

1. Select LINE IN or DIGITAL DIN using the MULTI-CHANNEL button.
2. Select FOURPOINT/5.1 DIN mode using the CMSS button.

Playing Microsoft DirectSound3D or EAX Games

1. Select LINE IN or DIGITAL DIN input using the MULTI-CHANNEL button.

2. Under CMSS on your *DTT3500 Digital* decoder amplifier, select FOURPOINT/5.1 DIN to fully enjoy up to 5.1-channel gaming experience from Microsoft DirectSound3D or Creative EAX titles.
3. For Sound Blaster Live! users, enable the multi-channel configuration on your PC.

Playing Conventional Games

Select MUSIC or MOVIE by pressing the CMSS button until the LED for MUSIC or MOVIE mode lights up.

Playing Console Games

1. Select LINE IN input using the MULTI-CHANNEL button and/or OPTICAL input using the DOLBY DIGITAL/PCM AUDIO button.
2. Select MUSIC or MOVIE by pressing the CMSS button until the LED for MUSIC or MOVIE mode lights up.

Playing DVD Movies

Using PC-DVD player on a PC

Select the COAXIAL input using the DOLBY DIGITAL/PCM AUDIO input selection button.

Listening to PC-DVD movies with 5.1-channel Dolby Digital sound

Be sure to listen only to the digital program source. You can do this by:

1. Making sure your PC-DVD player's stereo downmix is not sent to your soundcard. For example, disconnect any cable link between the cards, or
2. Muting the CD input of your computer's software mixer/volume control application.

Using software DVD player on a PC

1. Set the software DVD player to pass through AC-3 to DIGITAL DIN output.
2. Select DIGITAL DIN using the DOLBY DIGITAL/PCM AUDIO input selection button.

Using set-top DVD player or PlayStation 2

Select OPTICAL or COAXIAL using the DOLBY DIGITAL/PCM AUDIO input selection button.

For movies with Dolby Digital (AC-3) soundtracks

This signal is detected automatically and the DOLBY DIGITAL LED lights up. You will experience Dolby Digital 5.1-channel output.

For 2-channel movies which are Dolby Surround-encoded carried within the Dolby Digital compressed bitstream

The Dolby Pro Logic decoder will automatically decode the program for 5.1-channel movie experience.

For 2-channel DVD movies which are Dolby Surround-encoded

The Dolby Pro Logic decoder will automatically decode the program for 5.1-channel movie experience.

Playing VCD Movies

Using PC-DVD player on PC

Select the COAXIAL input using the DOLBY DIGITAL/PCM AUDIO input selection button.

Using SoftMPEG player or PlayCenter on PC

1. Select LINE IN or DIGITAL DIN input using the MULTI-CHANNEL button.
2. Select the Movie mode by pressing the CMSS button until the LED for Movie mode lights up.
This mode lets you experience the surround sound with 5.1-channel output; all dialog and central sounds will be heard through the center speaker, while music and off-stage sounds are heard through the other four satellites.
3. If you are using PlayCenter to play the VCDs, disable all CMSS effects in your PlayCenter - use only DTT3500 Digital's Movie mode.

Using set-top VCD player

1. Select LINE IN input using the MULTI-CHANNEL button.
2. Select the Movie mode by pressing the CMSS button until the LED for Movie mode lights up. You can experience surround sound instead of mono/stereo sound; all dialog and central sounds will be heard through the center speaker, while music and off-stage sounds are heard through the other four satellites.

For VCD movies with Dolby Surround-encoded stereo program

Use the Dolby Pro Logic decoder for 5.1-channel movie viewing experience.

For source connected to OPTICAL/COAXIAL/DIGITAL DIN:

1. Select OPTCAL/COAXIAL/DIGITAL DIN input using the DOLBY DIGITAL/PCM AUDIO button.
2. Press the DOLBY PRO LOGIC button until the DIGITAL IN LED lights up.

For source connected to ANALOG LINE IN

1. Select LINE IN input using the MULTI-CHANNEL button.
2. Select ANALOG IN using the DOLBY PRO LOGIC button.

CD Audio Music

Enjoying CD Audio on PC

1. Select LINE IN or DIGITAL DIN input using the MULTI-CHANNEL button.
2. Select the Music mode by pressing the CMSS button until the LED for Music mode lights up. This mode creates an enveloping five-speaker surround effect that enhances stereo music.

Karaoke Music

Singing Karaoke on PC with Sound Blaster Live! only (with Creative PlayCenter)

1. Select LINE IN or DIGITAL DIN input using the MULTI-CHANNEL button.
2. Ensure your microphone is connected to the MIC IN of Sound Blaster Live!.
3. Enable the Microphone source in the Mixer.
4. Select one of the seven Karaoke modes under Environment in Creative Launcher.
5. Click the Audio Menu button on the Creative PlayCenter to hear only the music, i.e. with the vocal portion masked out.

Singing Karaoke on PC with Sound Blaster Live! and Creative PC-DVD Decoder Card (with Creative Navigator application)

1. Ensure your microphone is connected to the MIC IN minijack of Sound Blaster Live!.
2. Enable the Microphone source in the Mixer.
3. Select one of the seven Karaoke modes under Environment in Creative Launcher.
4. Select the COAXIAL input using the DOLBY DIGITAL/PCM AUDIO input selection button.
5. Press the AUDIO MODE button of the *DTT3500 Digital* decoder amplifier unit until you hear only the music i.e. vocal portion is masked out.

Important!

Playback Levels

DTT3500 Digital is intended for individual or small group listening and can achieve surprisingly high output levels. However, playing heavy-bass program material continuously at overly loud, distorted levels may blow the system's internal fuse.

The fuse can be replaced only by a qualified representative. To avoid this inconvenience and a possible non-warranty repair charge, reduce the playback volume when the system shows obvious signs of stress, for example, when it sounds raspy, fuzzy, and/or muddy.

Specifications

DTT3500 Digital 6-Channel Amplifier

Satellite speaker:
7 watts RMS per channel

Center Channel amplifier:
21 watts RMS per channel

Subwoofer amplifier:
35 watts RMS per channel

These specifications apply to *DTT3500 Digital* operating from the supplied 15V 4A DC power adapter.



EAX is a collection of powerful, innovative audio technologies. Developed by Creative's world-class audio scientists and built into groundbreaking Personal Digital Entertainment (PDE) solutions, EAX is changing the way you experience audio. EAX offers advanced, interactive audio and high-definition sound to a new generation of portable audio appliances, audio applications, and internet services. Advanced technologies for incredible, cutting edge audio are built into powerful tools. EAX-enabled products let you shape and customize your audio experience, and include advanced audio features for music composition and sound design.

The DTT3500 Digital is the most complete 5.1 speaker system for movies and games. The built-in Dolby Digital decoder and 24-bit Digital-to-Analog Converter (DAC) delivers a thrilling, high quality home theater audio experience. When used with Sony's PlayStation 2™, direct digital interfacing via the optical connector is possible,

assuring the best possible DVD audio experience.

Different audio content from games to movies to music files can be further enhanced with the advanced EAX technologies incorporated into the DTT3500 Digital. "Movie" mode expands the soundfield across the full 5.1 speaker configuration - great for enhancing playback of regular stereo audio soundtracks. In addition, the "Music" mode provides special processing to enhance playback of audio CDs and music files.

o the original purchaser, Cambridge SoundWorks, Inc. will warrant the speaker system to be free of defects in material and workmanship for a period of one (1) year from date of purchase. With respect to defects, Cambridge SoundWorks will, at its option, replace the product or repair the defect in the product with no charge to the original purchaser for parts or labor.

Technical Support

We are committed to giving you the best product as well as the best technical support.

Note: Before contacting “European Help Line”, please ensure that you have read the ‘Troubleshooting’ Appendix. The Creative web site at www.creative.com gives you access to the latest drivers and troubleshooting tips.

For fast and efficient Technical Support solutions, please use the Creative Web Support services in the first instance. If your Creative product was pre-installed in your computer, your primary source of technical support is the Personal Computer supplier who provided the system.

The European support area on our web site at www.creative.com is continuously updated and contains the following:

- | | |
|--------------------------------|---|
| FAQ: | Access the latest information on Creative products with advice on how to resolve commonly asked questions |
| Solve Your Own Problem: | Enter keywords to search the comprehensive library of product and technical information |
| Download Drivers: | Quick access to the latest Creative drivers |
| Library: | Find the documents for a wide range of Creative products |
| Email Your Problem: | Complete the technical support web form and submit for a response |
| Telephone Support: | European Telephone Support contact details. See also European Helpline section in manual for contact details. |

If You Have a Problem

Please retain all contents including packaging and proof of purchase until you are fully satisfied with product.

If you have a problem installing or using your Creative product, please use the Creative Web Support and/or Telephone Support services for assistance. Note the following information for reference should you require technical assistance:

- The model and serial number of your Creative product
- Error information on the screen and how it came about
- Information on the adapter cards which may be causing a conflict
- Hardware configuration information such as the base I/O address, IRQ line, DMA channels used
- Motherboard information: BIOS manufacturer/version and chipset manufacturer
- Type and version of your operating system, e.g., DOS 6.0, Windows 3.1x, Windows 95, Windows 98 or Windows NT

If, after using the Creative support services, you believe your Creative product to be defective, you should verify the purchase date and the take the appropriate action as detailed below:

Less than 30 days since date of purchase

Should your store receipt indicate that the product is less than 30 days old, you have the option of returning the full product to the dealer/retailer for a replacement or credit. The 30-day time period may not apply in all instances, so please check the seller's replacement/credit terms.

More than 30 days since date of purchase

Contact European Technical Support to clarify the nature of the problem and to obtain details of our repair returns procedure. Creative Labs requires that all returns for repair/replacement must first be issued with an authorisation number.

Returning a product for repair

- ❑ Contact Technical Support to receive your authorisation number for repair/replacement of product.
- ❑ Technical Support will communicate how to return the product in question for repair/replacement.
- ❑ You should only return the hardware item in question and return it to the address detailed by Technical Support. Please retain all software, accessories and the original packaging.
- ❑ Please quote the authorisation number clearly on the outside of the packaging in which you return the hardware item in question.
- ❑ Upon receipt of the faulty item, Creative Labs will process your request and arrange a return or replacement.

Creative may replace or repair the product with new or re-conditioned parts, and the faulty parts will become the property of Creative. The warranty period for your repaired/replacement item is 90 days from the date of shipment from Creative, or what is left on the original item's warranty, whichever is longer.

To avoid tariffs when shipping a product to Creative Labs from outside the E.U., you must complete the relevant customs documentation before shipping the product (please allow 30 days).

Limited Warranty

Creative Labs (Ireland) Limited (“Creative”) warrants to you, the original purchaser only, that the hardware product will be free of defects in materials and workmanship for a period of two years after the date of purchase, or such other period as may be expressly specified by Creative or required by applicable law (“Warranty Period”).

Creative’s entire liability and your remedy will be, at Creative’s sole discretion, the repair or replacement (with the same or similar model) of any hardware or accompanying item(s) not meeting the “Limited Warranty” explained above that is returned to Creative’s authorised distributor or dealer during the Warranty Period with a copy of your receipt.

What this warranty does not cover

Note: This warranty gives you specific legal rights. You may have other rights which vary from country to country. Certain limitations in this warranty are not permitted by the jurisdiction of some countries, so some limitations here may not apply to you.

To the maximum extent permitted by applicable law, Creative disclaims all other warranties and conditions, expressed or implied, including the conditions of quality, merchantability or fitness for a particular purpose with respect to the use of this product. Creative also disclaims any obligation to support products for all operating environments - for example, by ensuring interoperability with future versions of software or hardware. In no event shall Creative or its licensors be liable for any indirect, incidental, special or consequential loss or for any lost profits, savings or data arising from or relating to the use of this product, even if Creative or its licensors have been advised of the possibility of such loss.

Specifically, this warranty does not cover failures of the product which result from accident, abuse, misuse, alterations (by persons other than Creative or its authorized repair agents), moisture, corrosive environments, shipping, high voltage surges, or abnormal working conditions. This warranty does not cover normal wear and tear. You are specifically advised to take a backup copy of any software provided with the Creative product for security purposes.

Creative European Help Line

CREATIVE LABS (IRELAND) LTD.,

Technical Support Department,
Ballycoolin Business Park, Blanchardstown, Dublin 15,
Ireland.

Fax: +353 1 8205052

United Kingdom

Tel +44 (0) 870 8760876

Germany

Tel +49 69-66982900

Ireland

Tel +353 1 820 7555

France

Tel +33 1 55 46 87 77

Spain

Tel +34 (91) 66 25 116

Italy

Tel +39 02 4828 0000

Austria

Tel +43 (01) 589 244 320

Belgium

Tel +32 (02) 7171 198

Denmark

Tel +45 3525 9498

Finland

Tel +358 (09) 2294 3101

Norway

Tel +47 2305 0401

Sweden

Tel +46 (08) 7519 147

Holland

Tel +31 (0) 205040616

Switzerland

Tel +41 (01) 2121 868

Portugal

Tel 800 8 53066

Czech Republic

Tel +353 1 8066964

Poland

Freephone 00 800 353 1229

Hungary

Freephone 06 800 12222

Russia

Tel +353 1 8066967

Operating Hours / Heures d'ouverture / Öffnungszeiten / Ore d'ufficio / Horario de oficina / Openingstijden / Horário de abertura

EUROPE

Mon-Fri	:	Business Hours	Sat-Sun & Public Holidays	:	Closed
Lun. au vend.	:	Heures de bureau	Sam., dim. et jours fériés	:	Fermé
Mo-Fr	:	Geschäftszeiten	Sa, So & gesetzl. Feiertage	:	Geschlossen
Lunedì-venerdì	:	Orario d'ufficio	Sábato, domenica e festivi	:	Chiuso
Lunes-Viernes	:	Horario de oficina	Sábados, domingos y festivos	:	Cerrado
Maandag-Vrijdag	:	Kantooruren	Zat.-Zon. & Nationale Feestdagen	:	Gesloten
Segunda a sexta-feira	:	Horário de expediente	Sábado, domingo e feriados	:	Fechado

Internet To receive technical support via the Internet, please e-mail: support@europe.creative.com

Web Site www.creative.com