

P.O. Box 654
Katy TX 77492-0654
Toll Free: (866) 794-8357
Tel: (281) 391-6750
Fax: (281) 391-6760
Email: info@cruiserlift.com

FAST MASTER PRODUCTS, INC.

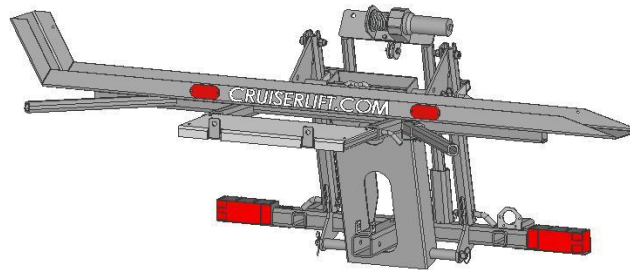

Memo

To: Cruiserlift Customer
From: Fast Master Products, Inc.
Date: 8/6/2008
Re: Cruiserlift System / Motor Coach Installation Requirements

The following information is provided in order help you evaluate whether your motor coach will accept the Cruiserlift System.

The Cruiserlift System was not designed to install onto Fifth Wheel Travel Trailers. The chassis frames on these trailers were not designed to have that much weight downloaded on the frame. We have had numerous customers inform us of the pitfalls of installing a lift to the rear of their trailer. Competitive systems will install these systems onto fifth wheel trailers. Fast Master Products, Inc. will not sell a system that is to be installed onto a fifth wheel trailer. A couple of the problems are listed below.

1. The weight of the lift and bike reduced the king pin weight creating massive sway at 50 mph.
2. The added weight of the lift and bike bent the chassis frame. Slide outs will not work anymore, and the gel-coat is cracking above the frame bend.

The Cruiserlift system was not designed to install onto Class-B or Class-C motor coaches. The chassis frames are usually not strong enough to handle the weights involved. Also, the rear axle gross weight rating-Rear (GAWR-Rear) may not be sufficient enough. There is an exception to that statement. The newer Class-C diesel coaches such as the Dynamax Grand Sport and Dynaquest coaches may handle the loads associated with the system.

The system was designed to install onto either a Class-A Diesel, and selected Class-A Gas motor coaches. If you are not sure if the system will mount to your coach, the following information should help.

1. Does the original chassis frame run from the front of the coach to the rear of the coach without any welded on extensions? Welded on extensions will not hold the weight being loaded to the rear of the coach. A short extension (less than 2') may be reinforced.
2. If the original chassis frame extends to the rear of the coach, or close, use the attached **"Added Weight Diagram"** formula to determine the amount of weight that will be added to the rear axle of your coach. (Form is attached) (If downloading from the web site, also download the Added Weight Formula)
 - ✓ This formula will tell you how much weight you will be adding to the rear axle of the coach with the system, and bike loaded. The formula takes into consideration the amount of overhang from the rear axle to the rear of the coach. The longer the overhang, the greater the leverage, thus increasing the weight to the axles.
3. **Check the manufacturers GAWR-Rear** (Gross Axle Weight Rating-Rear) rating for the rear axle. This information is usually in the coach manual, or on a sheet of paper taped on the inside door of one of the closets.
4. If you have not done so, you need to **Weigh The Coach** for a reference point. You should have a starting weight of your coach with all added supplies and equipment that you normally travel with. This will give you a base line to go by. Without a starting point weight, you will only be guessing at your available axle weight. You can obtain weights from truck stops, gravel pits, concrete plants, etc. These are usually at a small charge of \$5.00 to \$8.00. Next time you use your coach and pull into a truck stop for fuel, this is a good time to weigh the coach since you already have the normal cargo loading onboard. Most all truck stop scales are segmented, so you just have to run on top of the scales with your front and rear wheels on separate platforms.
5. Once you have the **Actual** rear axle weight (GAWR Rear) from the weigh slip, and the **Manufacturers** rear axle gross weight rating (GAWR Rear), subtract the actual axle weight from the manufacturers specifications. This will give you the available weight you may add to the rear axle. Compare the available weight for your coach and the figure from the Added Weight Formula.

Example:

Manufacturers (GAWR-Rear) Gross Axle Weight Rating– Rear	24,000 Pounds
Actual (GAWR-Rear) Gross Axle Weight Rating– Rear (After weighing)	19,500 Pounds
Subtract Actual from Manufacturers (GAWR) (Available weight)	4,500 Pounds
Results from Added Weight Formula	2052 Pounds

Since the available weight calculates to **4,500** pounds, and the results from the Added weight Formula is **2,052** pounds, there is enough room to add the Cruiserlift system.

6. If there is enough room available, then the system may be able to be installed. Generally, with gas coaches - the longer the coach, the greater the rear overhang there will be from the rear axle. This relates to a significant leverage factor associated with adding weight to the rear of the coach. When the motorcycle is loaded onto the coach, the rear of the coach will drop, thus bringing the front of the coach upward. This could lead to handling issues while driving. Unfortunately, the coach manufacturers do not normally include automatic leveling air bags on gas coaches as they do on diesel. It could be that you might need to add air bags to compensate for the added weight to the rear of the coach and re-level the coach with the bike loaded.
7. If you are not able to install the Cruiserlift System, there is an alternative solution available. The Swivel Wheel System is now available for install onto all Class-A and Class-C motor coaches, fifth wheel travel trailers, full size pick-ups, and full size SUV's with a Class-III or Class IV receiver hitch. You can see the system by visiting either www.cruiserlift.com, or www.swivelwheel.com. **The Swivelwheel systems may not be utilized in conjunction with towing a vehicle behind the coach.**
8. If towing a car, another alternative is the Tandem Tow Dolly. With this product, you can take your motorcycle, golf cart, or ATV along with your car. You can see the tow dolly at www.cruiserlift.com.

There is a word of caution when looking at the Tandem Tow Dolly. If you are currently or are looking to tow a jeep or other vehicle that is normally towed with all four wheels on the ground, check with the vehicle manufacturer to see if that vehicle is able to be towed by two wheels on the ground. We are told that the jeep cannot be towed by just two wheels on the ground.

9. If you have any further questions, please contact us toll free at (866) 794-8357 or email us at info@cruiserlift.com.

DIMENSIONS NEEDED TO DETERMINE ADDED WEIGHT ON REAR AXLE

DIRECTIONS: 1) FILL IN THREE BLANKS BELOW
2) PLUG NUMBERS INTO EQUATION
AND SOLVE

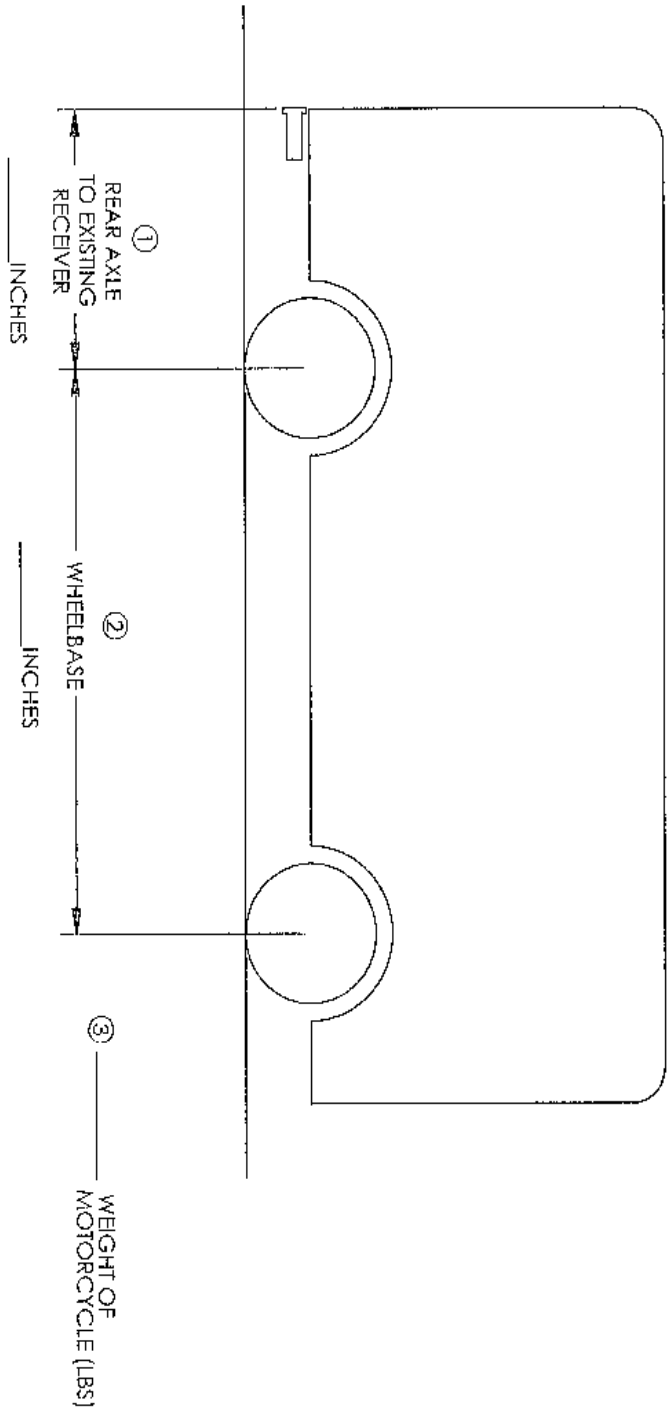

ADDED WEIGHT ON REAR AXLE = $A \times B + C$

$A = \text{Weight of motorcycle} + 460 =$ _____

$B = \text{Wheelbase} + \text{Rear Axle to Existing Receiver} + 23 =$ _____

$C = \text{Wheelbase} =$ _____

Installation Instructions for Receiver Weldment

Figure 1

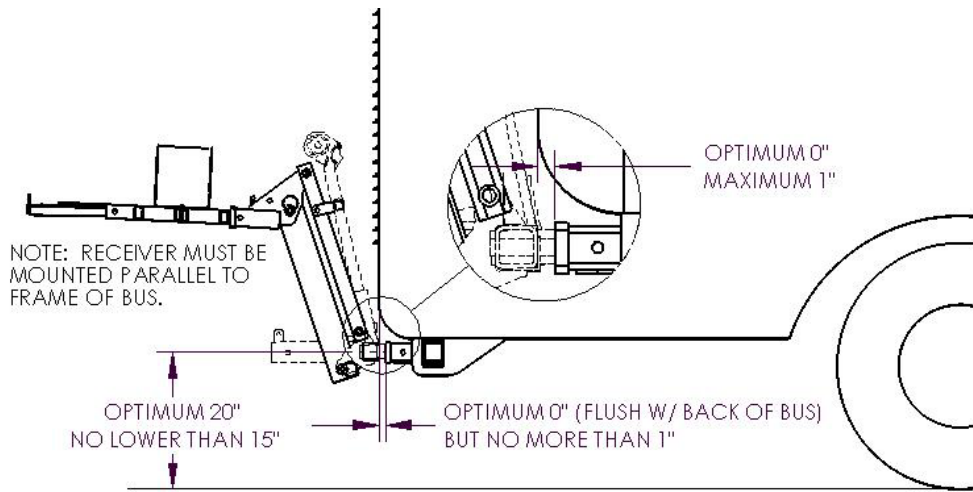

Figure 2

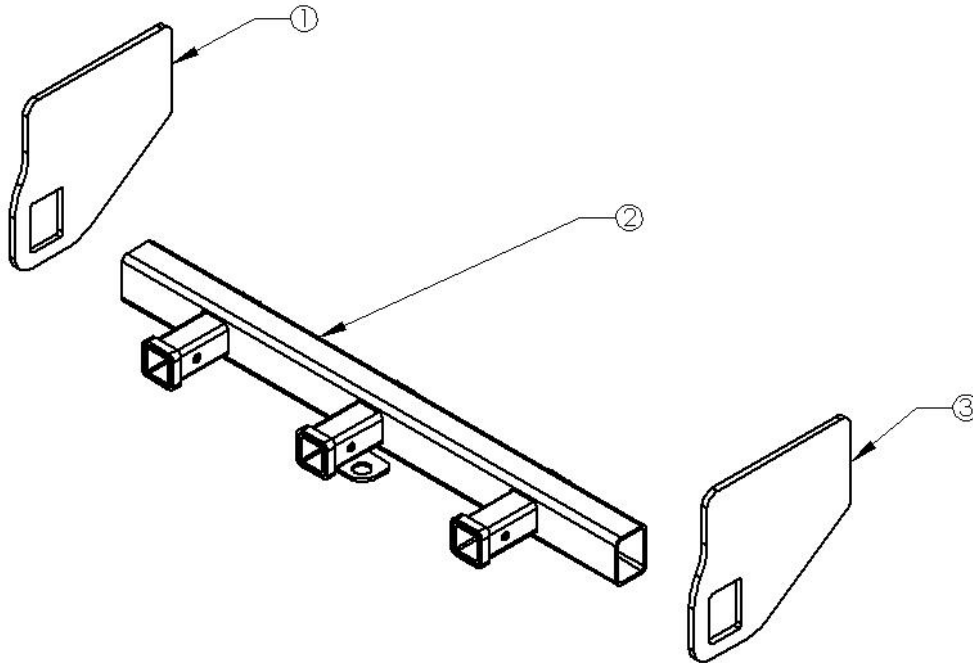

Table 1

Item	Description
1	Driver Side Weldment Plate
2	Receiver Bar
3	Passenger Side Weldment Plate

Step 1) Park coach on level ground such that rear bumper is same height from ground as during travel.

Step 2) Disconnect Battery Cables from all batteries on coach.

Step 3) Weld item 1, Driver Side Weldment Plate, to frame of coach. Weldment Plate may be trimmed to eliminate interferences in order to fit against the frame of the coach. A minimum of 30 linear inches of at least a 3/8" fillet weld **must** be used to attach Weldment Plate to frame of coach. Refer to figure 1 for dimensions to determine location of Weldment Plate to frame of coach.

Step 4) Slide Receiver Bar, into opening in Driver Side Weldment Plate. Use jack stands or appropriate means to hold Receiver Bar level and centered on the coach. The dimensions shown in Figure 1 should be checked to insure proper location of Receiver Bar. Tack weld Receiver Bar to Driver Side Weldment Plate.

Step 5) If item 3, Passenger Side Weldment Plate, needs modification do so at this time.

Step 6) Weld item 3, Passenger Side Weldment Plate to the frame of the coach. A minimum of 30 linear inches of at least a 3/8" fillet weld **must** be used to attach Weldment Plate to frame of coach.

Step 7) Tack weld Receiver Bar to Passenger Side Weldment Plate.

Step 8) Weld Receiver bar to Weldment Plates using a 3/8" fillet weld in the following order:

- a) Bottom of driver side
- b) Bottom of passenger side
- c) Top of driver side
- d) Top of passenger side
- e) Front of driver side
- f) Front of passenger side
- g) Back of driver side
- h) Back of passenger side

NOTE: It is not necessary to weld both sides of each Welding Plate. However there must be a minimum of 14 linear inches of at least a 3/8" fillet weld between **each** Welding Plate and the Receiver Bar.

NOTE: Warping of the Receiver Bar may occur if weld order is not followed.

NOTE: Over-heating of Receiver Bar may cause tubing to draw

WARNING: BOLTING WELDING PLATE TO FRAME OF COACH IS NOT AN ACCEPTABLE MEANS OF ATTACHMENT. THE NECESSARY WELD FOR EACH SIDE IS LISTED ABOVE!

THE CRUISERLIFT UNIT IS DESIGNED FOR USE ON COACHES WITH FRAMES THAT EXTEND FAR ENOUGH TOWARDS THE REAR SUCH THAT WELDMENT PLATES CAN BE ATTACHED WITHOUT EXTENSIONS. FOR RV'S WITH EXTENSIONS, FASTMASTER PRODUCTS WILL NOT WARRANTY THE UNIT.

As a reference only, we have provided a photo of an install. With this specific coach, there was not enough room to weld the plates to the chassis frame. Another piece of like channel was welded under the main chassis frame. The Cruiserlift Weldment plates were then attached to this new channel as shown below.

