

proense Digital Panel Meter DPM1 Series

Instructions

AUTOMATIONDIRECT.com

3505 HUTCHINSON ROAD
CUMMING, GA 30040-5860

Models:

DPM1-A-LP



Features

- 48 x 24mm 1/32 DIN
- 4 digit (-1999 to 9999) red LED display
- Selectable decimal point
- Process (4-20mA DC)
- Loop powered
- Display scaling or process teaching modes
- Configuration for direct or reverse acting linear processes
- Total configuration lock out

Dimensions and Mounting

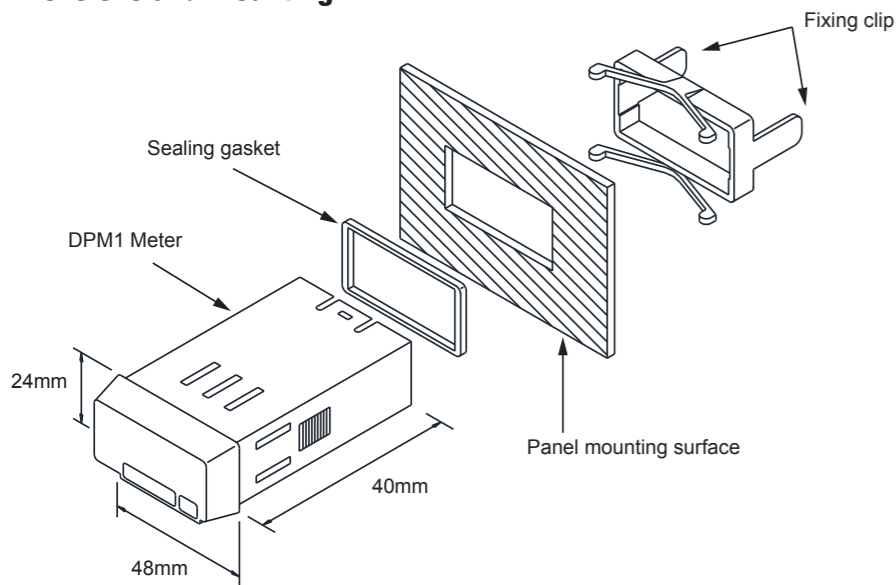

To install the instrument, prepare a 45mm x 22mm panel cut-out and slide the unit inwards making sure to place the sealing gasket between the front side panel and the front bezel.

While holding the unit in place, put the fixing clip around case and slide it until it reaches the panel at the rear side.

Press slightly to fasten the clip to the latching slots on the case and get the unit fully assembled and close fitted to achieve a good seal.

To remove the instrument from the panel, pull the rear fixing clip latching tabs outwards until they are disengaged, then slide the fixing clip back over the case.

Installation	
Dimensions	48 x 24 x 40mm (1/32 DIN)
Panel Cutout	45 x 22mm (Max. panel thickness 7mm)
Case Material	Polycarbonate UL 94 V-0



WARNING: To minimize the risk of potential safety problems, you should follow all applicable local and national codes that regulate the installation and operation of your equipment. These codes vary from area to area and it is your responsibility to determine which codes should be followed, and to verify that the equipment, installation, and operation are in compliance with the latest revision of these codes.

Equipment damage or serious injury to personnel can result from the failure to follow all applicable codes and standards. We do not guarantee the products described in this publication are suitable for your particular application, nor do we assume any responsibility for your product design, installation, or operation.

If you have any questions concerning the installation or operation of this equipment, or if you need additional information, please call us at 1-800-633-0405 or 770-844-4200.

This publication is based on information that was available at the time it was printed. At Automationdirect.com® we constantly strive to improve our products and services, so we reserve the right to make changes to the products and/or publications at any time without notice and without obligation. This publication may also discuss features that may not be available in certain revisions of the product.



WARNING! Electric shock danger

1. Keep away from high-voltage and high-frequency environment during the installation to prevent interference. Avoid using the device in environments which contain: (a) dust or corrosive gas; (b) high humidity or high radiation; (c) shock or vibration
2. Make sure the input power is switched off when installing or uninstalling the DPM1 to prevent harm to personnel or equipment.
3. Before switching on the input power, check the signal connection, e.g. the input voltage and polarity. Voltage that is too high may cause damage to the DPM1.
4. Front cover should be cleaned only with a soft cloth soaked in neutral soap product. DO NOT USE SOLVENTS.

Wiring Terminals

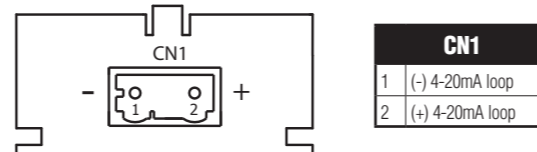

Terminal	
Connector	CN1
Wire cross section	0.08 to 2.5mm ² (28 to 12 AWG)
Strip length	8 to 9mm
Manufacturer	Wago 231-302/026-000
Cage clamp connection	Insertion tool or screwdriver with 0.5 mm x 3.0 mm blade

Connection Terminal

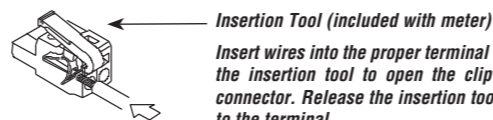

This instrument conforms with the following community directives: EMC 2004/108/CE. Refer to the instructions in this insert to preserve safety protections

To guarantee electromagnetic compatibility, the following guidelines should followed:

- Use shielded cable for signal wiring.
- Cable cross-section must be $\geq 0.25\text{mm}^2$

Additional Help and Support

- For additional technical support and questions, call our Technical Support team @ 1-800-633-0405 or 770-844-4200



Configuration

Programming Keys (Bottom View)

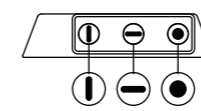

- **ENTER:** Enters configuration and validates data and parameters.
- **SHIFT:** Selects mode or shifts blinking digit in configuration.
- ↑ **UP:** Increases value of blinking digit in configuration.

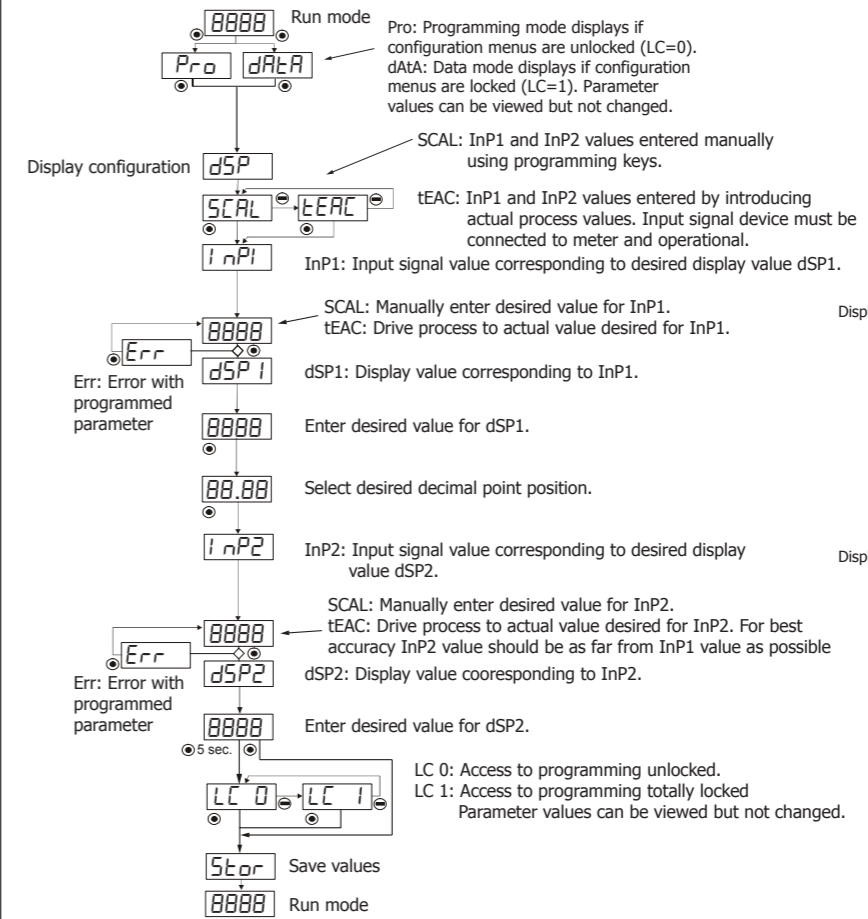

Direct Acting Process

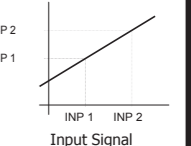

Reverse Acting Process

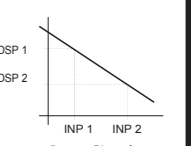

Technical Specifications

Input	Range	4-20mA
	Resolution	$\pm 0.01\text{mA}$
	Impedance	10 Ω
Accuracy (@ 23°C $\pm 5^\circ\text{C}$)	Maximum error	$\pm (0.1\% \text{ of reading} + 3 \text{ digits})$
	Temperature coefficient	100 ppm/ $^\circ\text{C}$
	Warm-Up time	5 minutes
Power Supply		Loop powered
Voltage Drop on Input Loop	4-20 mA	<5V
Conversion	Technique	Single slope
	Resolution	16 bits
	Conversion rate	62 times per second
Display	Range	-1999 to 9999, selectable decimal point position
	Type	4 digit 10mm (0.4"), red
	Display refresh rate	2 times per second
	Display/input overrange indication	Err
Environmental Conditions	Operating temperature	-10°C to +60°C (14°F to 140°F)
	Storage temperature	-25°C to +85°C (-13°F to 185°F)
	Relative humidity (non-condensing)	<95% @ 40°C (104°F)
	Maximum altitude	2000m
	Frontal protection degree	IP65
Environmental Air		No corrosive gases permitted
Agency Approvals		CE

Model DPM1-A-LP Example Application:

4-20mA input, 0.0 to 100.0 display (direct acting process using Scale Mode)

Programming Keys (Bottom View)

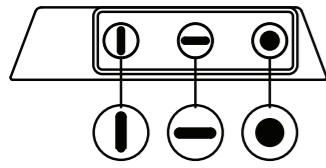

- ENTER:** Enters configuration and validates data and parameters.
- SHIFT:** Selects mode or shifts blinking digit in configuration.
- UP:** Increases value of blinking digit in configuration.

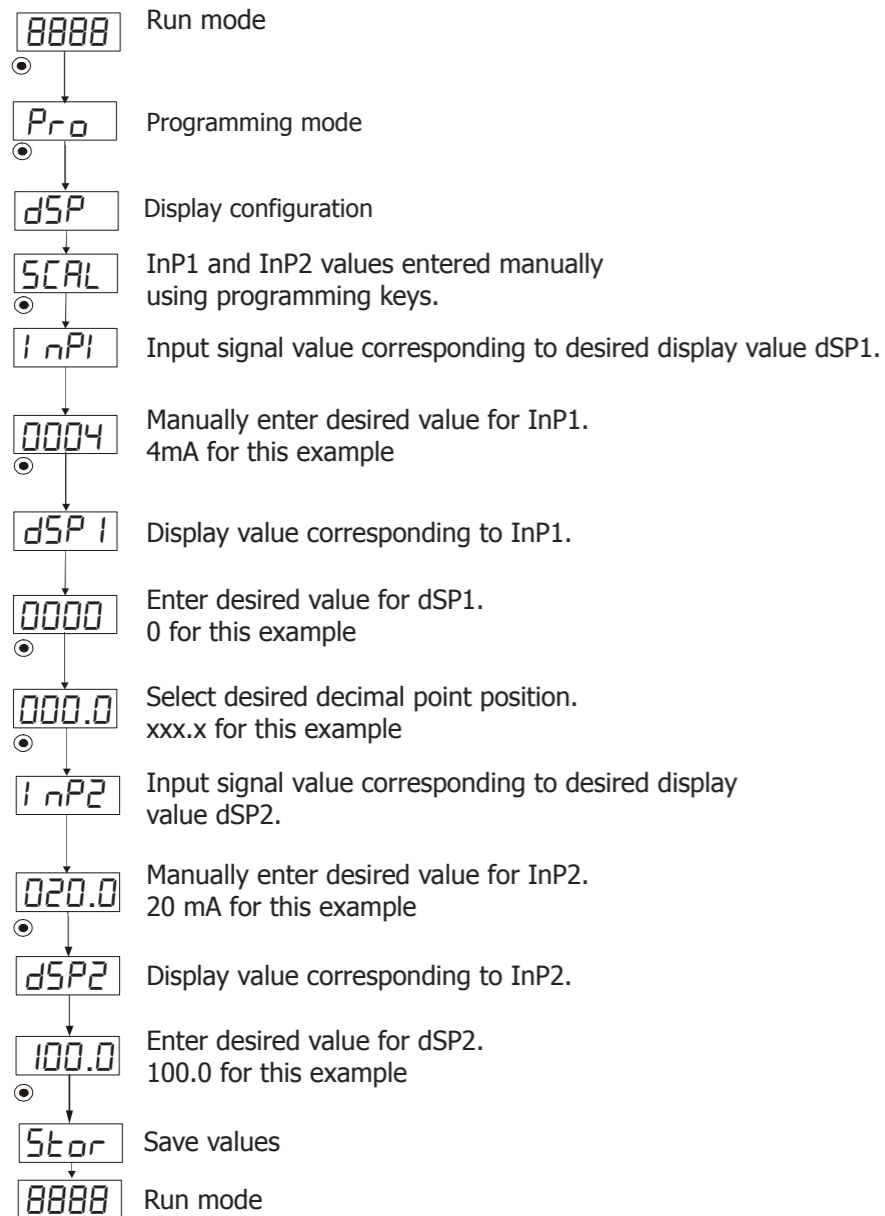

Direct Acting Process

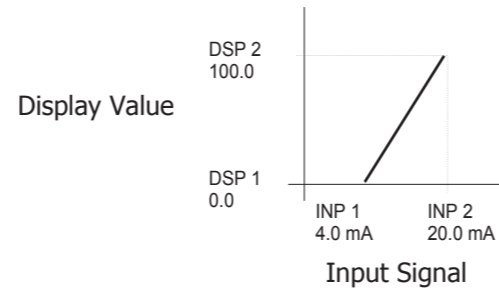

Notes