

Documentation & Coding Compliance for Otolaryngology – Head & Neck Surgery

Stephen R. Levinson, (M.D.)

www.PracticalEM.com

ASALLC@aol.com;

ASA,LLC

Disclaimer

- This presentation is designed to provide accurate and authoritative information in regard to the subject matter covered. The information includes both reporting and *interpretation* of materials in various publications, as well as *interpretation* of policies of various organizations. This information is subject to individual *interpretation* and to *changes over time*
- Presenter has personal interests in consulting, presenting, writing about, and developing software in order to help physicians achieve compliant medical records and to help them facilitate quality patient care

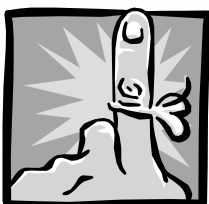

ASA,LLC

Attendee Demographics

- Physician offices
- Hospital / Academic Medical Center
- Medicare / Insurers
- Consultant
- HIT
- Other



ASA,LLC

Today's Agenda: *Otolaryngology - FMS*

Principles of procedure coding

- Selecting appropriate codes
 - When and how to use procedure modifiers
 - Ear and Balance Procedures
 - Nose & Sinus Procedures
 - Oropharynx & Head & Neck Procedures
 - Plastic & Reconstructive Procedures
-
- *Coding E/M & procedures on same DOS ???*
 - Codes with XXX global designation
 - E/M modifiers and how to use them compliantly
 - Office diagnostic procedures (0 & 10 day global)

Compliance Tools

- CPT® (AMA)
- ICD-9 (AMA)
- RBRVS for Physicians
 - RVUs
 - Global periods
- CCI
- www.ENTcodingtoday.com, Encoder Pro, or other web based tools



Setting the Table

- Discussion is NOT about black & white rules, but about principles & tools and working in the gray zone
- Format – open dialogue with questions and critiques
 - Umpty-three thousand ENT codes; please ask about those of interest
 - NOT the med school definition of a “lecture”

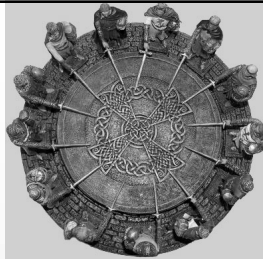

Medical Record Formats? – MDs/staff

- Data Storage
 - Paper
 - Electronic
 - EHR
 - Scanning system
- Data entry
 - Writing on paper
 - Dictation
 - Transcription
 - Voice recognition software
- Using some form of template for operative reports?
 - In O.R.
 - In office



Coding Practices

- Who does coding for Procedures
 - Physician primary
 - Coder primary
 - Is there review when questions?
- Who does coding for E/M services
 - Physician primary
 - Coder primary
 - Is there review when questions?
- Are there educational conferences scheduled with coders & MDs
 - Regularly scheduled group sessions
 - As needed group sessions

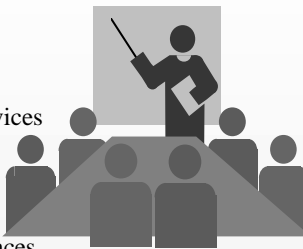

Coding Procedure Services



Coders' Role in Procedure Coding

- When coder does primary coding:
- Review operative report
 - Operation performed section is only the starting point
 - Must review details of op report to confirm accuracy of operative designation
 - Then select appropriate code(s)
- If any question of documentation or coding, must review with physician
- When the physician does the primary coding:
- Coder reviews the report to confirm that documentation supports the submitted codes
 - And to assess if additional procedures were also performed that should be coded
- If any question of documentation or coding, must review with physician

Coders' Role as Educator

- Physicians need understand coding - to appreciate the details that must be documented in their dictation to support coding of the procedure performed
 - For example, if physician submits code for total ethmoidectomy (31255) must document performance of surgery on the posterior ethmoid cells
 - (“if it wasn’t documented, it wasn’t done”)
- Should discuss any discrepancies, add a dated correction note if necessary (and if appropriate)
- Should lead to prevention of discrepancies in future cases

Coders' Tools for Auditing Procedures

- CPT (AMA)
- ICD-9 (AMA)
- HCPCS Level II
- Medical Dictionary
- ?Anatomy book (e.g., Netter)
- Photocopy of operative note
- Highlighter



Suggested Architecture (*Template*) for an Op Note

- Patient information
- Surgeon
- Date of Operation
- Operation Performed
- Pre-op diagnosis
- Post-op diagnosis
- Indications for surgery
- Operative findings
- Procedure - *detailed* and procedure specific description of operation

Use of *Macros* ???

- Which components of procedure description are acceptable for macro?
 - Even for this, need protection by separate sections for indications and operative findings
- Which are not?

The Rubber Stamp



EHRs, Cloned Documents, & Medical Necessity

- “Cloned documentation does not meet medical necessity requirements for coverage of services rendered due to the lack of specific, individual information.
- All documentation in the medical record must be specific to the patient and her/his situation at the time of the encounter
- Cloning of documentation is considered a misrepresentation of the medical necessity requirement for coverage of services. Identification of this type of documentation will lead to denial of services for lack of medical necessity and recoupment of all overpayments made.”
 - Eugene J. Winter, M.D., Medical Director for First Coast Service Options, Inc.
 - http://www.alliance1.org/conferences/National2008/materials/medicaid/Medicare_Document.pdf

No Rubber Stamp



The Foundation Guidelines for Coding Any Procedure (CPT Introduction)

- “Select the name of the procedure or service that accurately identifies the service performed. Do not select a CPT code that merely approximates the service provided. If no such procedure or service exists, then report the service using the appropriate unlisted procedure or service code”
- “When necessary, modifying or extenuating circumstances are added”
- “Any service or procedure should be adequately documented in the med record”



Guidelines for Coding Multiple Procedures

- All procedure codes (except those designated XXX) include a CPT-defined surgical package:
 - Local or topical anesthesia
 - One related E/M encounter on day of (or one day before) the procedure, subsequent to the decision for surgery
 - Immediate post-op care, including dictation and communication with family and/or other physicians
 - Evaluation in recovery area
 - “Typical postoperative follow-up care”



What is Included in “Typical” Follow-Up?

- “Follow-up care for therapeutic surgical procedures includes only that care which is usually a part of the surgical service. Complications, exacerbations, recurrence, or the presence of other diseases or injuries requiring additional services should be separately reported”
- Be aware (& wary) of the CMS non-compliant variation on this package
 - Complications ARE included in their global package



Modifiers

- When > 1 procedure performed on same date, several modifiers may apply (as defined in Appendix A of CPT)
- Without the appropriate use of modifiers, insurer software will bundle all services into a primary code
- Do not submit codes for two procedures when one is a component of the other
- Modifiers: -51, -59

Commonly Used Procedure Modifiers

- -22 *unusual services: greater than usually required*
- -50 bilateral procedure: Used to identify performing identical operations on both sides for services that are not already identified as bilateral in CPT
 - E.g., 31254.50
 - 42826 does not need a modifier since the RVU vignette describes this as a unilateral procedure
- -51 multiple procedures: used only when procedures are not components
 - Advises insurer software to pay both services
 - Also triggers (by convention) a 50% reduction on all secondary procedures (except add-on & -51 mod exempt)

Commonly Used Procedure Modifiers

- -58 performance of a planned or staged procedure during the post-operative period
- -59 distinct procedure service: one procedure that would normally be a component of another (& therefore not submitted) is being submitted because it was appropriate due to different site, different encounter, separate lesion, etc
 - Used only when a different modifier not appropriate
- -62 two co-surgeons performing distinct parts of a procedure
 - What is payment policy of Medicare & insurers on this modifier?
 - What are the \$\$ consequences?

Commonly Used Procedure Modifiers

- -76 repeat procedure by same physician
- -77 repeat procedure by another physician
- -78 return to O.R. for a related procedure during post-op period (usually due to unexpected complics)
- -79 return to O.R. for unrelated procedure during post-op pd
- -80 assistant surgeon
 - What is payment policy of Medicare & insurers on this code?
 - What are the consequences?

Managed Care Non-Compliant Policies for E/M Codes with Procedure Modifiers

- Some turn off modifier functionality (i.e., pay only one code regardless of modifier)
- Non-compliant bundling edits that override the correctly used modifier
 - How many CCI edits?
 - How many Claim Check edits?
 - Suggest visiting www.CignaForHCP.com



Questions on Principles for Procedures?



Ear Procedures

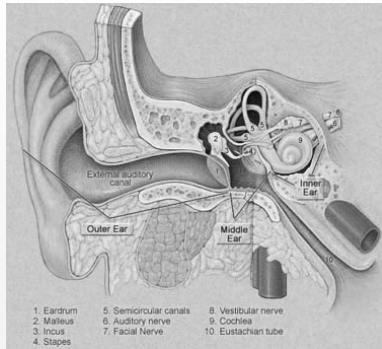

Ear Wax 101



- CPT code 69210
 - “Removal impacted cerumen” – define?
 - (separate procedure), one or both ears”
 - What is the global period designation for this procedure?
- How should this be coded when performed with another ear procedure (e.g., 69436 – tube placement)?
- How should this be coded with E/M service
 - When cerumen is the only reason for the visit?
 - When there is another problem addressed as well?
 - What must be documented in the chart for necessity?
 - Compliance problem when every occurrence of wax is “impacted” (this fails to pass the smell test)
- How to code for patients impacted every two months?

Using the Operating Microscope

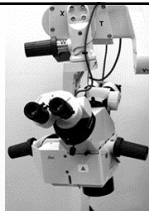

- CPT code 92504
- This is a separate procedure
- This has an XXX global designation
- 0.69 RVUs
- Can 92504 be billed with cerumen removal code?
 - CPT Asst 7/2005: permissible if required (document medical necessity!); not if used routinely
- Should 92504 be billed for routine ear examination?
- Under what circumstances is this service billable? What is the documentation required?
- CPT Asst (1/2005) advises use .52 modifier if unilateral

What About the Add-On Code for Using the Operating Microscope?

- “Surgical microscope is employed when...using the techniques of microsurgery”
- Code 69990 should be reported (without modifier -51) in addition to the code for the primary procedure
- “Do not report code 69990 where use of the operating microscope is an inclusive component!”
- Although CPT’s example list of codes not to add 69990 does not include any ear operations, it is not a comprehensive list
- The RVU vignettes for ear surgery codes include use of the operating microscope!

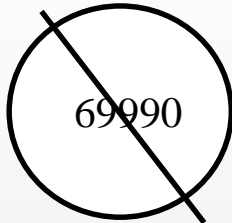

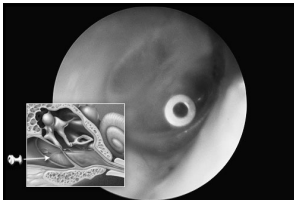

Tube Insertion

- Local anesthesia (office): 69433 / .50 bilat
- General anesthesia (office): 69436 / .50 bilat



Tube Removal (the \$750 tube removals)

- Tube removal in office: E/M
- Tube removal general anesthesia (unilat): 69424 (1.6 RVU)
- ? Repair, with or without preparation of perf, with or without patch: 69610 (7.73 RVUs)
- ? Myringoplasty: 69620 (12.49 RVU)

Coding for Acoustic Neuroma



- This is NOT a “skull base surgery”
- The 2 codes that “accurately identify the procedure performed are
 - 61526: craniectomy, bone flap craniotomy, transtemporal (mastoid) for excision of cerebellopontine angle tumor;”
 - 61530: “combined with middle/posterior fossa craniotomy/craniectomy”

Other Ear Questions?



- Mastoid?
- Stapes?

Nose & Sinus Procedures



Diagnostic Endoscopy

- 92511 is treated as a component of 31231 & 31575
- 31231 is treated as a component of 31575
- Interestingly, as of 2004, 31575 has lower RVU value (2.99 RVUs) than 31231 (4.68) or 92511 (4.1)
 - Prior to 2004, 31575 had the higher RVU value
 - Why?
- What do we think about this bundling policy from a clinical, coding, & RVU perspective?

Epistaxis Codes

- 30901: control nasal hemorrhage, anterior, simple (limited cautery &/or packing) any method
- 30903: control nasal hemorrhage, anterior, complex (extensive cautery &/or packing) any method
- 30905: control nasal hemorrhage, posterior, with packs &/or cauterization, any method; initial
- 30906: control nasal hemorrhage, posterior, with packs &/or cauterization, any method; subsequent
- Documentation critical to distinguish correct service
 - As well as showing separate E/M service when appropriate

Epistaxis Coding

- How do you code the services?
 - Initial visit for patient with 3 weeks of intermittent nasal bleeding, usually mild but occasionally moderate.
 - Perform & document level 3 initial visit care
 - Identify left anterior bleeding site and control with silver nitrate cautery and Surgicel topical pack
 - Codes?
 - Called to E.R. at 9 PM to see patient who is bleeding briskly from the left nostril. Remove old packing and place a full posterior pack
 - Codes?

Epistaxis Coding

- How do you code the services:
 - Initial visit for patient with 3 weeks of intermittent nasal bleeding, usually mild but occasionally moderate.
 - Perform & document level 3 initial visit care
 - Identify left anterior bleeding site and control with silver nitrate cautery and Surgicel topical pack
 - Physician documents use of nasal endoscope during evaluation and requests use of code 31238
 - Codes?



Nasal Trauma Operations

- Closed reduction nasal dorsum 21315 – 21320
- Closed reduction nasal septum 21337?
- Open reduction septum 21336
- Open reduction septum with closed reduction dorsum 21336 & 21320.51
- Open reduction septum & dorsum 21335

Nasal Septum Operations

- Repair deviated nasal septum • 30520
- Septal dermatoplasty • 30620

Turbinates

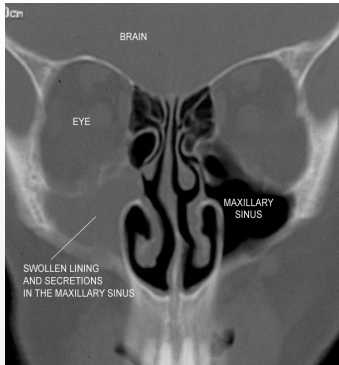

- Physiology
 - Warming
 - Humidification
 - Appropriate airway resistance (nasal-pulmonary reflex)

Turbinate Coding

- Prior to 2006 CPT changes, insurer software often bundled turbinate surgery into sinus surgery, stating that the middle turbinates are part of the ethmoid bone
 - And choosing to ignore the fact that the inferior turbinates are not part of the ethmoid bone
- Coding ambiguities resolved with 2006 semantics, which define the procedures as relating only to the inferior turbinates

Turbinate Coding

- CPT procedure codes (changed 2006 to inf turbs)
 - 30801: cautery and/or ablation, mucosa of inferior turbinates, unilat or bilat, any method; superficial (3.4 rvu)
 - 30802: intramural (4.92 rvu) (this includes radiofrequency procedures)
 - 30930: fracture inferior turbinates, therapeutic (3.02 rvu)
 - 30130: excision inferior turbinate, partial or complete (7.15 rvu)
 - 30140: submucous resection of inferior turbinate, partial or complete, any method (7.68 rvu)
- 30801, 30802, & 30930 are components of 30130 & 30140
- Middle turbinate Rx (non-endoscopic), including concha bullosa, now coded as 30999 unlisted procedure
- 31240: endoscopic resection concha bullosa; NOT bundled into 31254 & 31255 per CCI

Turbinate Coding for Radiofrequency

- AAO-HNS position:
 - “For RFA of the turbinates, use CPT 30802, cautery and or ablation, mucosa or turbinates, unilateral or bilateral, any method (separate procedure); intramural”
 - “Or CPT 30999, unlisted procedure nose”
 - Code for “submucous resection of turbinates is not the best suited code, even when the -52 modifier for reduced services is applied”
 - Comment: this would NOT be a correct code! – the RFA does not involve a surgical resection of bone!

Commentary: Turbinate Anatomy & Physiology

- Turbinates swell and contract all the time as part of the normal alternating nasal cycle – membranes on one side are more congested than those on the other side; then it switches
- With a significantly deviated septum, there may be compensatory hypertrophy on the wide open side; *this usually resolves spontaneously after the septum is straightened*
- With chronic sinus infection or allergy, the turbinates congest; this usually resolves with resolution (medical or surgical) of the underlying problem

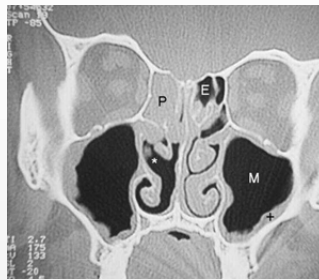

Commentary: Turbinate Controversies

- ENTs who operate on turbinates seem to do so in every case
 - Including bilateral inferior turbinate surgery with septoplasty
 - That is, the procedure is performed *routinely*, WITHOUT DOCUMENTED MEDICAL INDICATIONS
- Other ENTs (almost) NEVER operate on turbinates
- Both groups report similar excellent outcomes with their nasal and sinus procedures
- There is no evidence to support a medical benefit to routine turbinate surgery

Turbinate Controversies

- AAO-HNS “Clinical Indicators” state that indications for inferior turbinate surgery must include:
 - Chronic nasal obstruction due in part to inferior turbinate hypertrophy.
 - Failure of directed medical management with continued nasal symptoms (medications, allergy treatment, and duration of therapy)
 - Failure of medical treatment of rhinitis medicamentosa.
 - Symptoms of obstructive sleep apnea
- The “failure of directed medical management” might be considered (particularly if YOU are the patient) to include
 - Continued obstruction following straightening nasal septum
 - Continued obstruction following endoscopic sinus surgery

Turbinate Controversies

- When complications occur from turbinate surgery, they commonly have significant symptoms, which are chronic and usually cannot be effectively remedied!
 - Chronic dryness / crusting
 - Discharge / PND
 - Ozena !

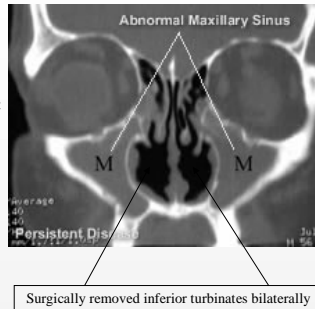

Turbinate Controversies

- **Opinion:** from an auditor’s & coder’s perspective, this is not an issue of coding; it is an issue of medical necessity
- That is, from a reviewer’s perspective, “how can routine performance of this procedure be medically ‘necessary’ when some physicians achieve successful outcomes without performing it?”
 - {The lesson of utilization of coronary bypass surgery}

CPT's Endoscopic Sinus Surgery Codes

- Nasal sinus endoscopy, surgical, with
 - 31254: ethmoidectomy, partial (anterior)
 - 31255: ethmoidectomy, total (anterior & posterior)
 - 31256: maxillary antrostomy
 - 31267: maxillary antrostomy with removal of sinus tissue
 - Note: medically necessary, NOT ROUTINE
 - 31276: frontal sinus exploration, with or without removal of tissue from the frontal sinus
 - 31287: sphenoidotomy
 - 31288: sphenoidotomy with removal of sinus tissue
 - Note: medically necessary, NOT ROUTINE
 - Others for repair CSF leak and orbital decompression
- These are all unilateral codes – require –50 modifier if bilateral

Endoscopic Frontal Sinus (31276)

- To employ this code, there must be evidence of *significant* frontal sinus pathology, and *significant* surgery must be performed
- Simply identifying the frontal sinus recess outlet is insufficient to apply this code
- Must have documented removal of frontal recess cells and diseased tissue, or removal of bone between frontal recess & supra-orbital ethmoid

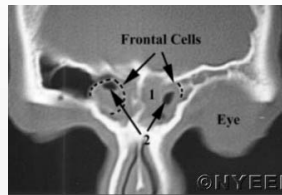

Endoscopic Repair of CSF Leak

- Cerebrospinal fluid leaks may occur spontaneously (rare), following trauma, or following ESS
- These occur from the bone at the roof of the sinuses, which separates sinus from brain
- CPT 31290: “Nasal/sinus endoscopy, surgical with repair of cerebrospinal fluid leak, ethmoid region”
- CPT 31291: “Nasal/sinus endoscopy, surgical with repair of cerebrospinal fluid leak, sphenoid region”
- Note: these codes are inclusive of surgical access through the ethmoid and sphenoid sinuses

Potential Insurer Non-Compliance for Endoscopic Sinus Surgery

- Ignoring -50 modifier in bilateral procedures
- Bundling inferior turbinate procedures into sinus surgery
- Bundling nasal septal procedures into sinus surgery (claiming that septum was done only for “exposure”)
 - MDs need appropriate DOCUMENTATION in the medical record to support appeal & medical necessity of performing septum
 - Examples of inadequate documentation of septal status?
 - Examples of adequate documentation of septal status?
- Ignoring the 0 day global designation for endoscopic sinus surgery, particularly with regard to debridements

Debridement Controversies

- CPT code 31237: “Nasal/sinus endoscopy, surgical; with biopsy, polypectomy or debridement (separate procedure)”
 - 8.63 RVUs
 - This is a unilateral code. Use -50 modifier if bilateral
- ENTs who submit for multiple debridements in the post-op period of ESS seem to do so in every case
 - That is, the procedure is performed routinely, without documented medical indication other than “routine” post-op care
- Other ENTs employ 0 – 1 debridement in nearly every case
 - That is, the procedure appears to be physician specific, not patient specific. This fact mitigates against medical necessity
- Both groups report similar excellent outcomes
- Contention that mucosal-sparing benefits of micro-debriders eliminate significant scarring and therefore reduces indication for debridements
- There is no evidence to support a medical benefit to frequent routine debridement surgery

AAO-HNS Survey 2001

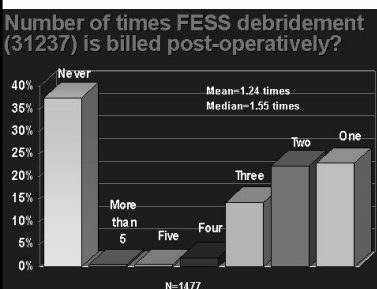

- 60% of respondents report usually billing for 0 – 1 debridements
- Critique: perhaps many are performing debridements & not billing for them due to insurer non-payment
 - Questionable concern IF the procedure meets criteria of AAO-HNS Policy Statement

Debridement Controversies

- AAO-HNS Policy Statement on debridement reports that:
 - Debridement of the sinus cavity.....involves transnasal insertion of the endoscope for visualization and parallel insertion of various instruments for the purpose of removal of postsurgical crusting, devitalized mucosa or other contaminated tissue. It is performed under local or general anesthesia in an office suitably equipped or operating room, depending on the clinical circumstances of the case.
- Review of charts of physicians who routinely perform multiple debridements rarely reveals documentation that supports these requirements. Particularly, most of these episodes use only topical anesthesia and fail to document the indications or significant abnormalities
- The conclusion is that there should be documentation of medical necessity and of performing this significant surgical procedure to support submitting 31237.
 - *Recommend a separate op report!*

Office Debridement Procedure Report

Procedure Report (Nasal Endoscopy with Polypectomy or Debridement)

Patient: _____ Account #: _____

Date of Operation: ____/____/____, M.D.

Surgeon: _____, M.D. _____, M.D.

Procedure: Fiberoptic Nasal Endoscopy with Polypectomy/ Debridement

Pre-operative Diagnosis: _____

Post-operative Diagnosis: _____

Indications for use of fiberoptic examination and treatment:

Chronic sinusitis

Nasal polyp(s)

Significant granulations and eschar following recent endoscopic sinus surgery

Procedure: The patient's nose was prepared with topical anesthesia, using cotton pledgets moistened with a solution of 4% lidocaine combined with 0.5% neosynephrine. Five minutes was allowed for anesthetic and vasoconstrictive effect, and the pledgets were removed. The rigid fiberoptic nasal endoscope was advanced into the _____ nostril(s) to examine the septum, turbinates, ostiomeatal complex, and nasopharynx. The turbinate and septal mucosa were then injected with 2% lidocaine with epinephrine 1:100,000. Ten minutes was allowed for anesthetic and vasoconstrictive effect. The remainder of the procedure was facilitated by visualization through fiberoptic nasal telescope(s):

Debridement

- **Opinion:** from an audit perspective, appropriateness of 31237 should not be a coding issue; it should be either:
 - Documentation issue
 - Documentation fails to meet AAO-HNS policy statement conditions to be considered a 'debridement' (rather than just a 'suctioning')
 - Medical necessity issue
 - From a reviewers perspective, "How can routine performance of this procedure be medically 'necessary' when some physicians achieve successful outcomes without performing it routinely?"

Coding for the Caldwell-Luc

- A traditional sinus operation that provides an external opening into the maxillary sinus thru the canine fossa.
 - Very useful for removing tissue in a totally opacified sinus
- CCI lists this as mutually exclusive with 31256 & 31267
 - If perform both, must charge for only one (or will be paid for the lower valued procedure)

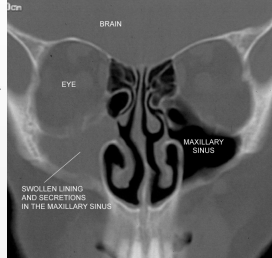

Coding for Open Frontal Sinusotomy

- Non-obliterative: a traditional sinus operation that provides for removal of sinus disease code 31086-87
- Obliterative: a traditional sinus operation that provides for removal of sinus disease and mucosa, followed by obliteration with fat removed from distant location (20926) code 31080-85
- Usually a coronal incision
- If also perform an endoscopic procedure, must charge for only one (or will be paid for the lower valued procedure) – mutually exclusive

Image Guided ESS

- Advent of a computerized CT tracking system to better define important surgical anatomical sites during surgery in real time has been useful to avoid potential complications in selected potential complex cases. *Indicated and approved only for complex surgical cases*
- CT guidance surgery is NOT considered *medically necessary* for all sinus surgery cases

AAO-HNS Policy on Image Guided ESS

- “Examples of indications in which use of computer-aided surgery may be deemed appropriate include:
 - Revision sinus surgery
 - *Distorted sinus anatomy* of development, postoperative, or traumatic origin
 - *Extensive* sino-nasal polyposis
 - Pathology (*significant*) involving the frontal, posterior ethmoid and sphenoid sinuses
 - Disease abutting the skull base, orbit, optic nerve or carotid artery
 - CSF rhinorrhea or conditions where there is a skull base defect
 - Benign and malignant sino-nasal neoplasms”
- *** The clinical record and the operative report, should clearly document one or more of these appropriate indications in cases where image guided surgery is billed; op report should document challenges
 - What if used “electively” by MD in non-complicated case?

Image Guided ESS

- CPT code 61795 (CT navigation)
 - To be replaced with 61782 in 2011
 - This is an add-on code
 - No modifier required
 - No multiple surgery reduction
 - Code encompasses all preparations as well as procedure
- *Medicare had been bundling 61795 into sinus surgery codes – reversed due to input from AAO-HNS & ARS
- Recommendation: obtain reimbursement policy (in writing) from each individual insurer
 - Options if this is not a “covered service”? (appeal, appeal to settlement administrator, patient appeal to employer, patient responsible for payment?)

Other Nose & Sinus Questions?



Oropharynx & Head and Neck

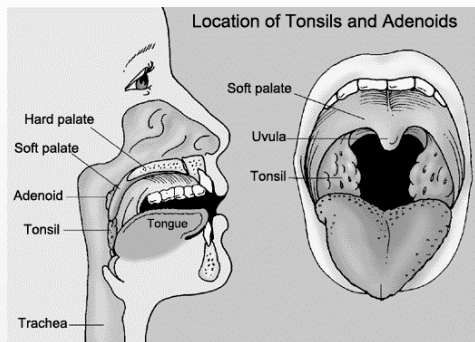

UPPP & Tonsillectomy Coding

- CPT code 42145:
palatopharyngoplasty
(15.33 rvu)
- CPT code 42826:
tonsillectomy age 12 or over
(6.86 rvu)
- How should we (compliantly)
code UP³ + tonsillectomy?
 - 42145 or
 - 42145 + 42826.51
 - What are our reference possibilities?

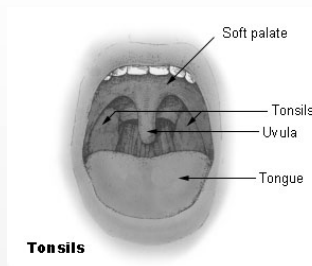

Diagnostic Endoscopy

- 31579: Laryngoscopy with (video) stroboscopy
 - Double the RVUs of 31575 (5.76 RVUs)
 - Requires documentation of medically necessary indications

Laryngoscopy & Bronchoscopy

- CPT code 31525: Diagnostic laryngoscopy (4.55 rvu)
- CPT code 31622: Diagnostic bronchoscopy (3.84 rvu)
- Commonly performed together, often with esophagoscopy as well, during head & neck cancer W/U.
 - Why is this a bundling issue?
 - How should we code 31525 + 31622?
 - Per CPT
 - Per CCI
 - Per insurers?



Classification of Neck Dissection

- RND: 38720
- Modified RND: 38724
- Suprahyoid dissection: 38700
- Extended neck dissection (beyond structures of RND):
 - 38720.22
 - 38724.22
- (CPT Assistant, August 2010)

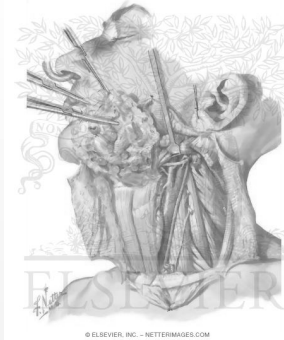

Other Oropharynx or Head and Neck Questions?



- Flaps & reconstruction
- Salivary glands
- Thyroid

Diagnostic Endoscopy

- 31579: Laryngoscopy with (video) stroboscopy
 - Double the RVUs of 31575 (6.23 RVUs)
 - Requires documentation of *medically necessary* indications

Coding for Skull Base Procedures (Any interest in covering?)

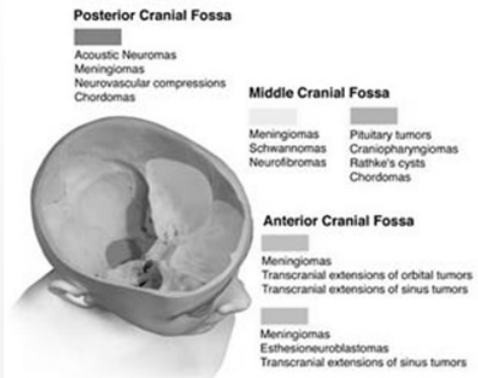

Coding for Skull Base Procedures

- Often requires several surgeons working together
- Each procedure has two or three components
 - Approach procedure (CPT 61580 – 61598)
 - Definitive procedure (CPT 61600 – 61616)
 - Repair/reconstruction procedure (CPT 61618 – 61619)
 - In cases requiring extensive dural grafting, cranioplasty, local or regional myocutaneous flaps, or extensive skin grafts
- Each surgeon bills only the component he or she performs
- If one surgeon performs more than one component, bills lesser procedure(s) with -51 modifier

Example Skull Base Procedures

- Anterior cranial fossa
 - Juvenile angiofibroma of the nasopharynx (jna)
 - Nasal meningioma
 - Inverted papilloma (or other tumor) involving cribriform
 - Erosive sphenoid lesions
- Middle cranial fossa
 - Glomus jugulare tumor
 - Certain parapharyngeal space tumors
- Posterior cranial fossa

Skull Base Procedure Questions?



Plastic & Reconstructive Procedures

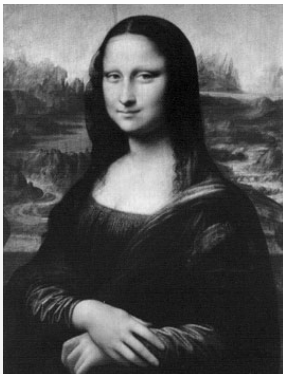

Components of Various Skin Procedures

- Excision of benign lesions (CPT 11400 – 11471)
 - Report each excised lesion separately
 - Size of excision includes lesion plus margins (measurement is of greatest diameter, and is made prior to excision)
 - Code includes simple closure (only)
 - Repair by intermediate or complex closure, or by reconstructive procedure, should be reported separately (using –51 modifier on lesser codes)

Components of Various Skin Procedures

- Excision of malignant lesions (CPT 11600 – 11646)
 - Report each excised lesion separately
 - Size of excision includes lesion plus margins (measurement is of greatest diameter, and is made prior to excision)
 - If re-excision due to frozen section, report only the one code, based on final size of excision
 - Code includes simple closure (only)
 - Repair by intermediate or complex closure, or by reconstructive procedure, should be reported separately (using –51 modifier on lesser codes)

Components of Various Skin Procedures

- Wound repair / closure, using sutures, staples, or tissue adhesive
 - Repair using adhesive strips only is reported by E/M
- Instructions for reporting
 - Each repaired wound is measured in centimeters
 - When multiple wounds repaired, add together the lengths of all wounds of same type of repair & same anatomic site category
 - When more than one classification of wound repair, report most complex as primary and others with –51 mod

Components of Various Skin Procedures

- Three types of wound repair: simple, intermediate, & complex
 - Simple: superficial wound involving primarily epidermis, dermis, or subcu without deeper tissues. Requires simple one-layer closure
 - Intermediate: additionally require layered closure of one or more deeper layers. May also refer to single layered closure of heavily contaminated wounds with extensive cleaning or removal of particulate matter
 - Complex: repair that requires more than layered closure, such as scar revision, debridement, extensive undermining, stents, or retention sutures
 - Includes creation of a defect for repair
 - Does not include excision of benign or malignant lesions

Components of Various Skin Procedures

- Adjacent tissue transfer or rearrangement (CPT 14000 – 14061)
 - Includes, but not limited to, Z-plasty, W-plasty, V-Y plasty, rotation flap, advancement flap, and double pedicle flap
 - Does not include mere undermining!
 - Includes excision of lesion
 - When applied in repairing traumatic lacerations, these procedures must be developed by the surgeon (not just be the incidental result of shape of the laceration)
 - To determine correct code, size of lesion (in square centimeters) include both the size of defect resulting from excision plus defect resulting from flap design

Coding Rhinoplasty

- These codes are NOT exclusively for “cosmetic” procedures
- Some nasal deformities affect patency of airway (ability to breathe properly)
- Strongly recommend insurer written approval of payment prior to surgery IF trying to obtain insurer coverage
 - 30400 (cartilage only) = 26.39 RVUs
 - 30410 (cartilage + bone) = 32.8 RVUs
 - 30420 (cartilage + bone + septum) = 35.28 RVUs



Coding Blepharoplasty (15822-15823)

- 15822 is for upper eyelid
- 15823 is for upper lid “with excessive skin weighting down lid” (i.e., functional problem)
- Find out insurer coverage requirements (visual fields, ophthal consult) and get prior approval, IF trying to obtain insurer coverage
 - 15823 = 15.41 RVUs (\$584 per eyelid (150% for 2)



Other Plastic & Reconstructive Questions?



Questions About Otolaryngology Coding??

thank you for your interest

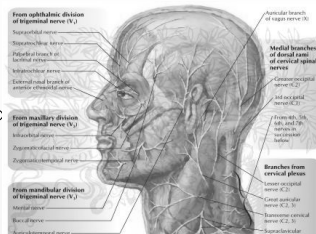

Stephen R. Levinson, M.D.
 ASALLC@aol.com
 www.PracticalEM.com

Coding E/M Related to Procedures



Looking at the guidelines

What Does Compliance Mean?



- Whose rules are they anyway?
 - CPT?
 - CMS?
 - CCI
 - Insurers?
 - Claim Check & its clones

Review of CPT Compliance *Rules*

- Surgical package definition (“global”) services include:
 - Local infiltration, blocks, topical anesthesia
 - Subsequent to decision for surgery, one related E/M service on date immediately prior to or on day of procedure (incl H&P)
 - Immediate post-op care, incl dictation & speaking with family &/or other physicians
 - Evaluating patient in recovery area
 - Typical postoperative follow-up care: “includes only that care which is usually a part of the surgical service. Complications, exacerbations, recurrence, or the presence of other diseases or injuries requiring additional services should be separately reported”

CPT Compliance Rules

- In CPT there are NO circumstances under which correctly applied modifiers may be ignored!
- Any procedure with a CPT code should be reported separately from an E/M service. Performance or interpretation of tests (with CPT codes) are not included in the E/M service
 - CPT 2006, page 2
 - Exception: a procedure that is included in the E/M description, for example?

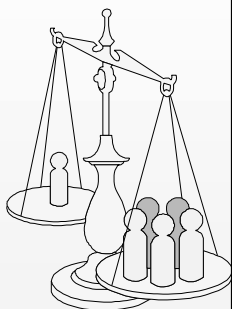

**CPT Compliance Rules

- Suggested Unifying Principle of CPT compliance (*by SRL*):
- Every service performed should be coded (and reimbursed) once; no service should be coded (and reimbursed) more than once
 - This interpretation also correlates with the RBRVS value vignettes and the column 1/column 2 analysis from CCI
- With added consideration of medical necessity, coders have two fundamental tools to apply when evaluating most coding questions

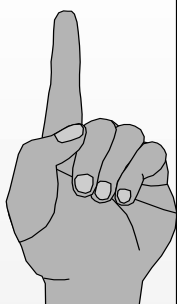

*Medical Necessity Definition

- Comprehensive definition applied in the HMO class action lawsuit settlements:
 - “Health care services that a Physician, exercising prudent clinical judgment, would provide to a patient for the purpose of evaluating, diagnosing or treating an illness, injury, disease or its symptoms, and that are
 - (a) in accordance with generally accepted standards of medical practice;
 - (b) clinically appropriate, in terms of type, frequency, extent, site and duration, and considered effective for the patient’s illness, injury or disease;
 - (c) not primarily for the convenience of the patient or Physician, or other Physician, and not more costly than an alternative service or sequence of services at least as likely to produce equivalent therapeutic or diagnostic results.”



*Medical Necessity Definition



- Comprehensive definition applied in the HMO class action lawsuit settlements (continued):
 - “For these purposes, ‘generally accepted standards of medical practice’ means standards that are based on credible scientific evidence published in peer-reviewed medical literature generally recognized by the relevant medical community, Physician Specialty Society recommendations, the view of Physicians practicing in relevant clinical areas and any other relevant factors.
 - Preventive care may be Medically Necessary, but coverage for Medically Necessary preventive care is governed by the terms of the applicable Plan Documents”

MD Documentation Basics: Learn The 2 Primary HCFA Audit Rules, + 1

- If care was not documented in the medical record, it was not done

– CMS Carriers’ Manual, section 7103.1(I))

- In accordance with the Social Security Law, Medicare will not pay for services that are not medically necessary

– Soc.Sec. section 1862

- + “Automation is not documentation

– *Practical EHR*



CMS Compliance Addition

- XXX global period designation: Procedures or services for which the global period concept does not apply

– An E/M code may be submitted with the procedure code without the use of a modifier

– {and it should be reimbursed!}

– Examples of XXX codes in ENT?

Looking at XXX Diagnostic Tests



- Any issues with any of these XXX codes?
- X-rays: e.g., CT sinus (70486)
- Lab tests: e.g., strep test (87880)
- Vestibular tests: 92541 – 92548
 - How multiple calorics (92543) reported?
 - What about vestibular tests by observ., not recording (92531 – 92534)?
- Audiology tests: 92551 – 92597
 - Hearing aids not covered 92590-92595
 - What about outmoded tests (e.g., Bekesy, SISI, tone decay)?
- Cochlear implants: 92601 – 92604
- FEES & FEEST: 92610 – 92617
- Auditory Function & Rehab: 92620 - 92633

Managed Care Non-Compliant Policies for XXX Codes

- Anthem policy on bundling acoustic reflex (92568) & reflex decay (92569) into audio
- Bundling of XXX (or other) procedures into the E/M service, as being “*incidental*”
- What are physicians’ options?
- Other reimbursement problems with XXX codes?



Questions on Compliance Rules?



Guiding Principle for E/M Care with Proc.

- Every procedure with a defined global period (including 90 day, 10 day, and 0 day) includes an E/M component
- This E/M component is described by CMS as “the usual pre- and post-operative work of a procedure with a global fee period”
- From an RBRVS perspective, each procedure code with a global period includes RVUs assigned for the usual E/M services associated with that code
- A physician should not submit codes for an E/M service that is within the description of “usual work” associated with a procedure
 - This would be billing twice for the same service: such coding is non-compliant and even risks being labeled as filing “false claims”

What Does Compliance Tell Us to Do When the E/M Care Exceeds the “Usual”?



- Correct Use of Modifiers in Conjunction with E/M
- Applicable Modifiers:
 - 24 (post-op period)
 - 25 (day of minor proc)
 - 57 (day of major proc)

Modifier -24

- When an unrelated E&M service (i.e., a service that is one of the services included in the global surgical package) is furnished, by the same physician, in the post-op period of a major or minor surgical procedure
- You must have sufficient documentation, and an ICD-9 code to establish the visit was unrelated to the surgery
 - Example: Mohs surgery done on left side of face. One month later, there is an E/M encounter to evaluate sinusitis
 - Example: Mohs surgery done on left side of face. One month later, there is an E/M encounter to evaluate growth on the right side of the face
- Non-compliant CMS policy related to the global surgical package?

Modifier -24

When NOT to use Modifier 24 for care within the global period:

- For removal of sutures
- When the reason for the encounter is related to the original surgery
- For taking care of an infected wound site from the surgery
 - CPT rules
 - CMS rules
- To handle complications from the surgery
 - CPT rules
 - CMS rules
- When a patient has to be taken back to the operating room for a complication of the surgery you bill for the procedure only. The examination would be considered part of the global service
 - CPT rules
 - CMS rules
- Insurer rules are variable & based on non-compliant software!

Modifier -25

- Significant Separately Identifiable Evaluation and Management Service by the Same Physician on the Same Day of a Procedure
 - 0 day or 10 day global period
 - Not 90 day global or XXX (“global concept does not apply”)
- This modifier indicates that on a day a procedure or service identified by a CPT code was performed, the patient’s condition required a significant, separately identifiable E/M service above and beyond the usual preoperative and postoperative care (global period) associated with the procedure that was performed. Assign the proper E/M code as appropriate for the services rendered and submit with –25 modifier.

The CMS Clarification of Using the – 25 Modifier

- “This modifier shall be used when the E/M service is above and beyond the usual pre- and post-operative work of a procedure with a global fee period performed on the same day as the E/M service.” (i.e., “*separately identifiable*”)
- “Different diagnoses are not required for reporting the E/M service on the same date as the procedure”
- “Both the medically necessary E/M service and the procedure must be appropriately and sufficiently documented.....in the patient’s medical record to support claims for payment of the E/M service and the procedure with the global fee period.”
- Look at PRACTICAL consequences

More on the Critical Importance of Compliant Use of Modifier -25

- One of the CMS carrier guidelines is that modifier –25 should be applied when E/M service is documented as being the basis for making the decision to perform the procedure
- Quote from “Medicare RBRVS”: “The CMS provides the following example: *Payment for a visit would be allowed in addition to payment for suturing a scalp wound if, in addition, a full neurological exam is made for a patient with head trauma. If the physician only identified the need for sutures and confirmed allergy and immunization status, billing for a visit would not be appropriate*”

Modifier -25

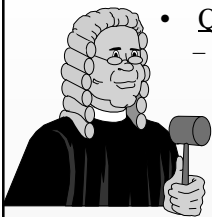

- Quote from “Practical E/M”:
 - “This deference to an example to illustrate ‘separate and identifiable service,’ rather than an actual definition, always reminds me of Supreme Court Justice Potter Stewart’s often quoted analysis of pornography: ‘I shall not today attempt further to define the kinds of material I understand to be embraced within that shorthand description (‘pornography’); and perhaps I could never succeed in intelligibly doing so. *But I know it when I see it.*”

Modifier -25

- Quote from “Practical E/M”:
- “Because of the method by which RVUs are determined, it is also *reasonable* to interpret that the amount of E/M care that is included in a minor or endoscopic office procedure is equal to the amount of E/M care that a physician would usually provide in this circumstance. This would include inquiring about the status of the medical problem being investigated with the procedure (ie, a brief HPI), a review of background medical health information to find out whether the patient has any pertinent changes that could affect the procedure (an update of the patient’s PMH and ROS), and a problem focused examination of the part of the body related to the procedure.

Modifier -25

- “Physicians should consider that this amount of problem-focused care is a component of such procedures, and they should not submit separate E/M codes for providing this level of care. This also tells us that it is appropriate to submit an E/M code (with an appropriate modifier), in addition to the procedure code, in circumstances where the E/M care the physician performed is more extensive and addresses issues beyond those related to the procedure itself.”

Modifier –25 Summary

- Patient’s condition required a significant, separately identifiable E&M service during same visit as a procedure
 - Different diagnoses are not required for by CPT for reporting (though this creates need for documentation)
 - Separate documentation is recommended
 - Modifier –25 is added to the appropriate level of E&M service
 - Ref: CPT Assistant, November 2004, pg 5
-
- CPT rules vs. CMS rules (decision for surgery) vs. private insurers’ “edits”
 - The problem with related ICD9 codes on established visits

Example Procedures for E/M & –25 Mod.

- Diagnostic endoscopy: 31575, 31231, 92511
 - Note that laryngoscopy RVUs 20% < nasopharyngoscopy
 - Significant RVU change in 2004: why did this occur?
 - For physicians who routinely use (and bill for) one or more of these codes to examine nose, nasopharynx, larynx, what is the compliant audit response? Explain?
- 69433 (tubes)
- Skin surgeries – excision, repair, flaps
- Recommend a separate op note to reflect separate services
 - Note should document the indications (i.e., medical necessity) warranting performance and reimbursement

Sample Template: Documentation Forms for Office Procedures

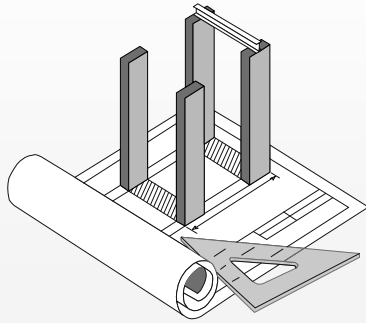

Procedure Report (Naso-Pharyngo-Laryngoscopy)

Patient: _____ Account #: _____

Date of Operation: _____ / _____ / _____ With Video Review

Surgeon: .MD .MD
 .MD .MD

Procedure: **Flexible fiberoptic flexible naso-pharyngo-laryngoscopy**

Pre-operative Diagnosis: _____

Post-operative Diagnosis: _____

Indications for use of fiberoptic examination: Pre-operative diagnosis plus need for improved visualization due to:

<input type="checkbox"/> Hyperactive gag reflex	<input type="checkbox"/> Posterior epiglottis position
<input type="checkbox"/> Obstructive base of tongue	<input type="checkbox"/> Inability to visualize anterior commissure
<input type="checkbox"/> Detailed evaluation of lesion	<input type="checkbox"/> History of treated neoplasm
<input type="checkbox"/> Enhanced mucosal visualization (to evaluate inflammation and edema)	
<input type="checkbox"/> Evaluation of documented obstructive sleep apnea, with Mueller maneuver	

Procedure: The patient's nose was prepared with topical anesthesia, using cotton pledgets moistened with a solution of 4% lidocaine combined with 0.5% neosynephrine. Five minutes was allowed for anesthetic and vasoconstrictive effect, and the pledget was removed. A flexible fiberoptic laryngoscope was advanced through the nostril to sequentially examine the nasopharynx, palate, oropharynx, base of tongue, epiglottis, larynx, hypopharynx and piriform sinuses.

Findings:

Nasopharynx:

<input type="checkbox"/> Normal mucosa	<input type="checkbox"/> Diffuse inflammation: mild/moderate/severe
--	---

Larynx and hypopharynx:

Vocal cords: <input type="checkbox"/> normal <input type="checkbox"/> abnormal	Arytenoids: <input type="checkbox"/> normal <input type="checkbox"/> abnormal
Retrocricoid: <input type="checkbox"/> normal <input type="checkbox"/> abnormal	Post commiss: <input type="checkbox"/> normal <input type="checkbox"/> abnormal

Palate and oropharynx / Other: _____

Managed Care Non-Compliant Policies for E/M Codes with -25 Modifier

- Control of epistaxis (30901 & 30903)
 - Insurers may bundle the E/M into the procedure, even when this includes a documented separate and identifiable service (& making decision for procedure)
 - Insurers may include the procedure in the E/M service (absolute violation of fundamental CPT compliance guideline)
 - What are physicians' options?
- Other reimbursement problems with E/M services and modifiers?



Modifier -57

- Identifies that the E&M service resulted in the initial decision to perform major surgery (90 day global period) within the global surgical package
 - That is, the E/M is within 24 hours of the time of the surgery
 - May be an outpatient code, inpatient code, consultation code, ER code, etc.
 - Examples??
- Indicates to payors' (computer software) that the E/M service is not part of the global surgical package
 - Should not be an issue with CMS (could request documentation)
 - May be an issue with individual insurers!
- Examples?

Caveats on Coding E/M & Procedures on the Same DOS

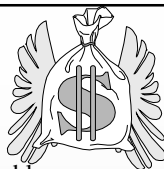

- Physicians are entitled to payment for each individual service; don't lose your \$\$\$
- It is essential to code compliantly and reasonably. When this is done,
- For insurers whose claims programs reimburse compliantly:
 - Payment should be made for E/M initial visits & consultations with procedures (decision for surgery)
 - Payments should be made for E/M established visits with unrelated Dx
 - For established visits with related Dx, software can't judge if separate & identifiable; can't judge if E/M included decision to perform procedure
 - Evaluate each insurer's response to documentation submitted w claim

Caveats on Coding E/M & Procedures on the Same DOS



- HOWEVER, some insurers claims programs reimburse non-compliantly:
 - Ignoring some or all modifiers
 - Bundling edits that over-ride modifiers
- For these insurers (& for E/M and procedure that have the same diagnosis) physicians must choose how to respond
 - Give free care charity to insurers (same as sending insurers a check for \$4,000 per month)
 - File appeal after appeal after appeal
 - Appeals cost more than funds recovered
 - Winning an appeal does not change the policy
 - Consider: 1 visit 1 service

Questions???