

option slots Five 32-bit EISA expansion slots (16-bit and 8-bit ISA compatible); bus-mastering option cards allowable in all slots

Speaker Internal; operation and volume controllable by software

Controllers

Diskette and tape drive Controller on the main system board supports up to two diskette drives in any of these formats:
 5 1/4-inch, high-density, 1.2MB
 5 1/4-inch, double-density, 360KB
 3 1/2-inch, high-density, 1.44MB
 3 1/2-inch, double-density, 720KB
 Supports one optional tape drive

Hard disk Interface on the main system board supports up to two IDE drives with embedded controllers

Processor Board

CPU 486SX/25 board: Intel 80486SX, 25 MHz microprocessor
 486DX/33 board: Intel 80486DX, 33 MHz microprocessor
 Both boards simulated 8MHz and other processor simulation speeds selectable through software

Cache memory 486SX/25 board: 8KB internal cache in the 80486SX microprocessor
 486DX/33 board: 8KB internal cache in the 80486DX microprocessor; 64KB Intel 82485MA-33 Turbocache module with write through two-way set associative cache memory and controller

Math coprocessor 486SX/25 board: two sockets available for optional Weitek WTL4167 and Intel 80487SX math coprocessors.
 486DX/33 board: internal coprocessor in the 80486DX and one socket for an optional Weitek WTL4167 coprocessor

Mass Storage Bays Up to five devices maximum; internal bay for two half-height or one full-height hard disk drives; externally-accessible bay for two half-height and one third-height or one full-height and one third-height drives

Power Supply

Type 235W, fan-cooled automatic input voltage sensing, thermally protected

Input ranges 98 to 132 VAC and 196 to 264 VAC, 47 to 63Hz

Maximum current At 110 Volts, 6 Amps; at 240 Volts, 3.3 Amps

Computer Specifications

Main System Board

System memory 4MB RAM standard on SIMMs; expandable using 1MB, 2MB, 4MB, or 8MB SIMMs up to 64MB (maximum); SIMMs must be 70ns, 36-bit, 72-pin gold-leaded, fast-page mode type

BIOS Two-part system BIOS; one 64KB permanent BIOS on an EPROM; one 64KB CPU-dependent BIOS in a ROM device

Shadow RAM Automatically copies the system BIOS from ROM into RAM; shadow RAM for video BIOS and external BIOS is software selectable

EISA configuration RAM 8KB SRAM; battery-backup

Clock/calendar Real-time clock, calendar, and CMOS RAM for configuration; battery backup

Interfaces

Serial Two RS-232-C, ISA compatible, asynchronous; 9-pin D-shell connectors

Parallel ISA compatible, 25-pin, D-shell connector

Mouse Mini DIN, 6-pin connector for PS/2 compatible mouse or other device

Keyboard Mini DIN, 6-pin connector for PS/2 compatible keyboard

EISA Series Desktop

Power supply maximum outputs

Output voltage (VDC)	Maximum current (Amps)	Minimum current (Amps)
+5	31 (+5%, -4%)	5
+12	6 (+5%, -4%, peak 8*)	0
-5	0.5 (±10%)	0
-12	0.5 (±10%)	0

* The +12 V peak current is limited to 30 seconds maximum.

Output cables Two main system board cables; five mass storage cables

Option slot power limits

Maximum current	+5 Volts	+12 Volts	-5 Volts	-12 Volts
For each slot	7 Amps	1.5 Amps	0.5 Amps	0.5 Amps
For all five slots	16 Amps	3 Amps	0.5 Amps	0.5 Amps

Keyboard

Detachable two position, 101 or 102 sculpted keys

Layout

Country-dependent main typewriter keyboard; numeric/cursor control keypad; four-key cursor control keypad; 12 function keys

Environmental Requirements

Condition	Operating range	Non-operating range	Storage range
Temperature	41° to 95°F 5° to 35°C	4° to 140°F -20° to 60°C	-40° to 140°F -40° to 60°C
Humidity (non-condensing)	20% to 80%	10% to 90%	5% to 95%
Altitude	-330 to 9900 ft -100 to 3000 m	-330 to 11880 ft -100 to 3600m	-330 to 39600 ft -100 to 12000 m
Maximum wet bulb	68°F 20°C	104°F 40°C	134°F 57%

Physical Characteristics

Width 17 inches (432 mm)
Depth 16 inches (406 mm)
Height 6.5 inches (165 mm)
weight Single diskette drive model (without keyboard): 26 lb (11.7 kg)

Power Source Requirements

120 Volt power source requirements

AC plug	Plug type	Reference standards	Power cord
	North America 125V, 10A	ANSI C73.11 NEMA 5-15-P IEC 83	UL Listed Type SVT or SJT, no. 18/3AWG or no. 16/3AWG, or -HAR- 300V, 10A or 13A

Main System Board Map

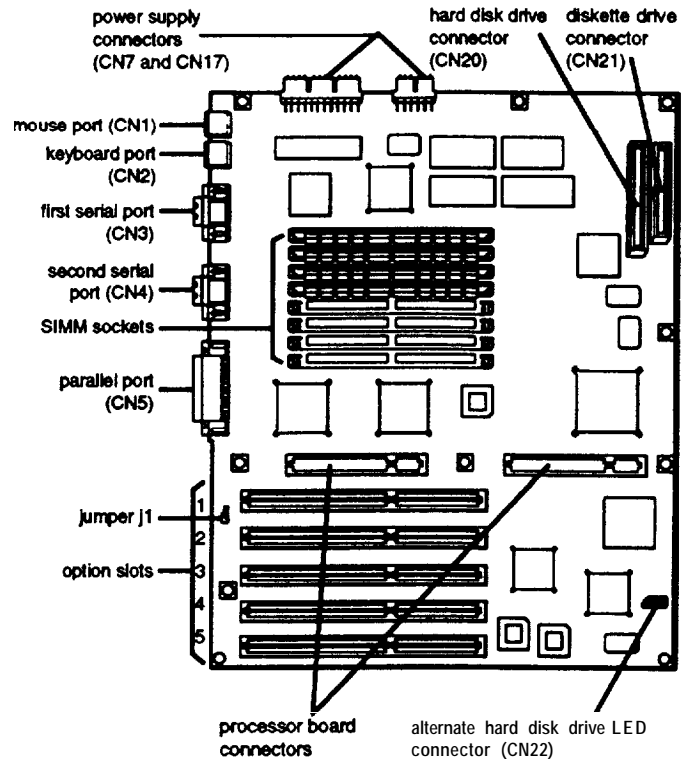

Main System Board Jumper

System board jumper J1 settings

Setting	Function
Pins 1 & 2	Disable password check
Pins 2 & 3	Enable password check

Processor Board Maps

486DX/33 processor board

Weitek WTL4167 math coprocessor socket
 Intel 80486DX 33 MHz microprocessor (with heat sink)
 cache module

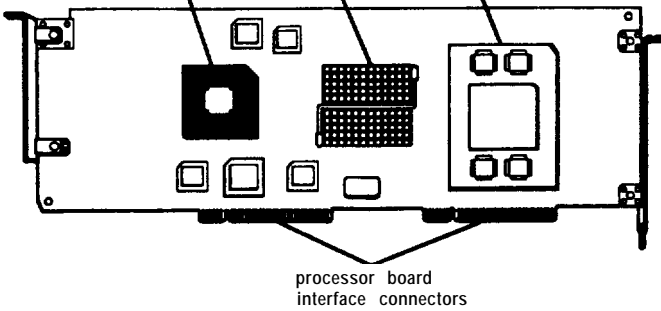

486SX/25 processor board

Weitek WTL4167 math coprocessor socket
 Intel 80487SX coprocessor socket
 Intel 80487SX microprocessor

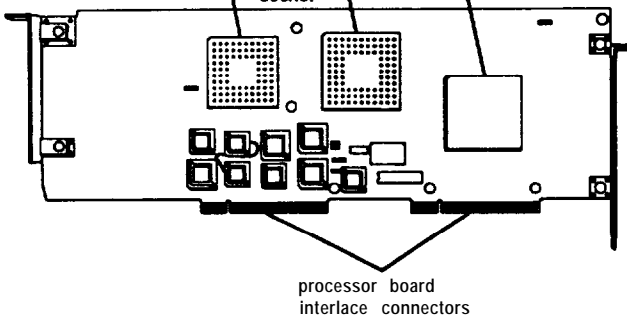

Main System Board Connectors

Parallel Port Connector (CN5)



Parallel port connector pin assignments

Pin	Signal	Pin	Signal	Pin	Signal
1	STROBE	10	ACK*	19	SIGNAL GND
2	DATA0	11	BUSY	20	SIGNAL GND
3	DATA1	12	PE	21	SIGNAL GND
4	DATA2	13	SELECT	22	SIGNAL GND
5	DATA3	14	AUTO*	23	SIGNAL GND
6	DATA4	15	ERROR*	24	SIGNAL GND
7	DATA5	16	INIT*	25	SIGNAL GND
8	DATA6	17	SELECTIN*		
9	DATA7	18	SIGNAL GND		

*Active low logic

Serial Port Connector (CN3, CN4)

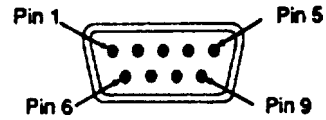

Serial port connector pin assignments

Pin	Signal	Pin	Signal
1	Data Carrier Detect	6	Data Set Ready
2	Receive Data	7	Request To Send
3	Transmit Data	6	Clear To Send
4	Data Terminal Ready	9	Rim Indicator
5	not used		

Keyboard and Mouse Connectors (CN1, CN2)

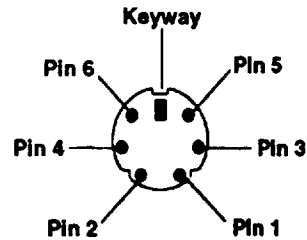

Keyboard connector pin assignments

Pin	Signal	Pin	Signal
1	Keyboard Data	4	+5 VDC
2	Reserved	5	Keyboard Clock
3	Ground	6	Reserved

Mouse connector pin assignments

Pin	Signal	Pin	Signal
1	Mouse Data	4	+5 VDC (fused)
2	Reserved	5	Mouse Clock
3	Ground	6	Reserved

Note: Although the keyboard and mouse connectors are physically identical, they cannot be used interchangeably.

EISA Series Desktop

Power Supply Connector (CN7)



System board power supply connector (CN7) pin assignments

Pin	Signal	Power supply connection
1	POWERGOOD	P8, Pin 1
2	+5 VDC	P8, Pin 2
3	+12 VDC	P8, Pin 3
4	-12 VDC	P8, Pin 4
5	GND	P8, Pin 5
6	GND	P8, Pin 6
7	GND	P8, Pin 7
8	GND	P8, Pin 8
9	-5 VDC	P8, Pin 9
10	+5 VDC	P8, Pin 10
11	+5 VDC	P8, Pin 11
12	+5 VDC	P8, Pin 12

Power Supply Connector (CN17)



System board power supply connector (CN17) pin assignments

Pin	Signal	Power Supply Connection
1	+5 VDC	P9, Pin 1
2	+5 VDC	P9, Pin 2
3	GND	P9, Pin 3
4	GND	P9, Pin 4
5	GND	P9, Pin 5
6	+12VDC	P9, Pin 6

System I/O address map

I/O address	Function
0000-000F	DMA controller 1 (8-bit)
0020-0021	Interrupt controller 1
0040-0043	Programmable interval timer 1
0048-004B	Programmable interval timer 2
0060, 0064	Keyboard controller
0061, 0065	Parity check I/O check. Timer control. Speaker, Refresh
0070	NMI mask
0070	RTC address strobe
0071	RTC data strobe
0080	Diagnostics port
0081-008F	DMA page registers (0-7), Refresh
00A0-00A1	Interrupt controller 2
00C0-00DE	DMA controller 2 (16-bit)
00F0	Numeric coprocessor
X170-X17F	Hard disk controller (secondary address)
X1F0-X1FF	Hard disk controller (primary address)
X376	Hard disk status register
X377	Hard disk address register
0278-027F	Parallel port 2 (secondary address)
02F8-02FF	Serial port 2 (secondary address)
0372,4,5,7	Diskette drive controller control/status registers (secondary address)
0378-037F	Parallel port 1 (primary address)
03BA-03D7	VGA registers
03F2,4,5,7	Diskette drive controller control/status registers (primary address)
03F8-03FF	Serial port 1 (primary address)
0400-040B	DMA1 control register
040C	Host CPU/EISA control register
040D	Stepping level register
040E, 040F	ISP test register (reserved)
0461	Extended NMI, reset control
0462	NMI I/O interrupt port
0464	Last 32-bit bus-master granted
0480-048F	DMA high-page register
04C2	reserved
04C6-04CE	DMA2 base/current count high
04D0	INT1 edge level control register
04D1	INT2 edge level control register
04D2, 04D3	reserved
04D4	DMA2 chaining mode
04D5	reserved
04D6	DMA2 extended write mode register
04D7-04DF	reserved
04E0-04EF	DMA stop register (#0,1,2,3)
04F0-04FF	DMA stop register (#5,6,7)
0800-08FF	Extended CMOS RAM
0C00-0C83	Configuration registers
46E8	VGA Setup mode register

DMA Controller

Direct memory access (DMA) improves system performance by allowing devices to access the system memory directly. This ability is provided by two 82C37 -compatible direct memory access controllers (DMACs) contained in the 82357. The seven independent 32-bit DMA channels are listed in the table below along with their associated DMA controller and their device assignments.

DMA request level

Level	Assigned Device
DRQ 0 (CTRL1)	Spare
DRQ 1 (CTRL1)	SDLC
DRQ 2 (CTRL1)	Diskette drive controller
DRQ 3 (CTRL1)	Spare
DRQ 4 (CTRL2)	(Cascade for CTRL1)
DRQ 5 (CTRL2)	Spare
DRQ 6 (CTRL2)	Spare
DRQ 7 (CTRL2)	Spare

Hardware interrupt (IRQ) map

Interrupt	Function
IRQ0	System timer
IRQ1	Keyboard
IRQ2	Cascade interrupt
IRQ3	Serial port 2
IRQ4	Serial port 1
IRQ5	Parallel port 2
IRQ6	Diskette drive controller
IRQ7	Parallel port 1
IRQ8	RTC
IRQ9	Redirect Int 0Ah (IRQ2 handler)
IRQ10	Unused
IRQ11	Unused
IRQ12	Mouse
IRQ13	Numeric coprocessor
IRQ14	Hard disk drive controller
IRQ15	Unused

System Memory Map

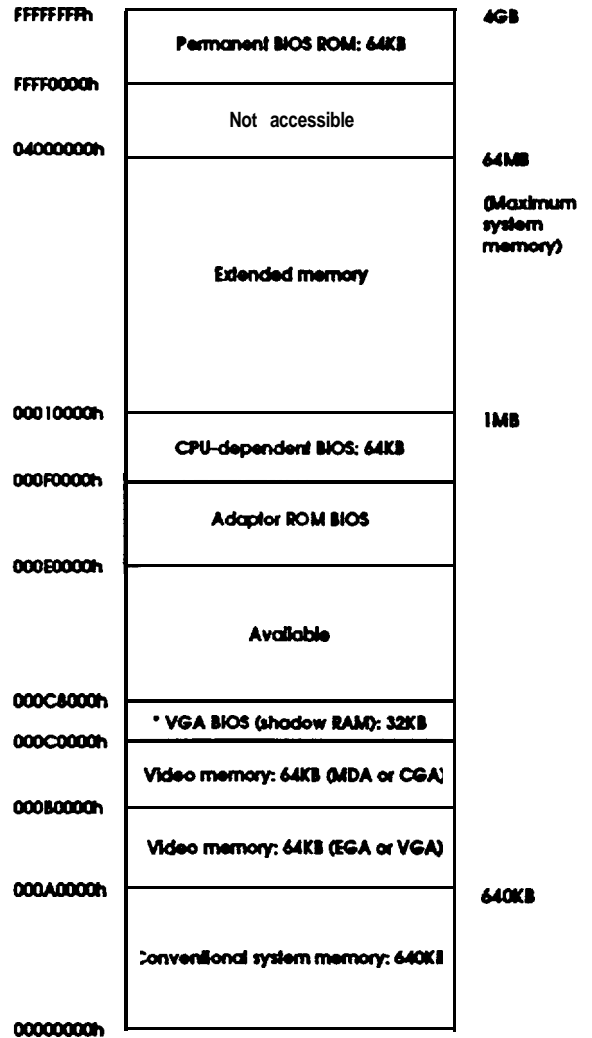

- Use of the *memory areas* for video memory and the video BIOS depends upon the type of video adapter card installed.

EISA Series Desktop

Hard Disk Drives

The following table lists the type of hard disk drives you can use in your computer. Check this table and the manual that came with your hard disk to find the correct type for the hard disk drive(s) installed in your computer. Then select that type at the hard disk drive Type prompt. If you do not find your drive type in the table, select User defined and enter your drive's parameters.

Hard disk drive types

Type no.	Type	Cylinders	Heads	Sectors	Precomp	Landing zone	MB	Drive name
00								No hard disk
01	ST-506	306	4	17	128	305	10.2	(1)
02	ST-506	615	4	17	300	615	20.4	
03	ST-506	615	6	17	300	615	30.6	
04	ST-506	940	8	17	512	940	62.4	
06	ST-506	940	6	17	512	940	46.8	
06	ST-506	615	4	17	—	615	20.4	
07	ST-506	462	8	17	256	511	30.7	
08	ST-506	733	5	17	—	733	30.4	
08	ST-506	900	15	17	—	901	112.1	
10	ST-506	820	3	17	—	820	20.4	
11	ST-506	855	5	17	—	855	35.5	
12	ST-506	855	7	17	—	855	48.7	
13	ST-506	306	8	17	128	319	20.3	
14	ST-506	733	7	17	—	733	42.6	
15								reserved
17	ST-506	612	4	17	0	663	20.3	
17	ST-506	977	5	17	300	977	40.5	Seagate 94205-51
18	ST-506	977	7	17	—	977	56.8	
19	ST-506	1024	7	17	512	1023	59.5	
20	ST-506	733	5	17	300	732	30.4	Toshiba MK-133FA
21	ST-506	733	7	17	300	732	42.6	Toshiba MK-134FA
22	ST-506	733	5	17	300	733	30.4	
23	ST-506	306	4	17	0	336	10.2	
24	ST-506	612	4	17	305	663	20.4	
25	ST-506	306	4	17	—	340	10.2	
26	ST-506	612	4	17	—	670	20.4	
27	ST-506	698	7	17	300	732	40.6	
28	ST-506	976	5	17	488	977	40.5	
29	ST-506	306	4	17	0	340	10.2	
30	ST-506	611	4	17	306	663	20.4	
31	ST-506	732	7	17	300	732	42.6	
32	ST-506	1023	5	17	—	1023	42.5	
33-36								none
37		683	16	38	0FFF	683	202.8	
38-40								none
41	ESDI	1022	5	34	—	1022	84.8	Seagate 94216-106 (2)
42	ESDI	1022	5	36	—	1022	89.8	Seagate 94216-106 (2)
43	ST-506	1024	8	17	512	1023	68	(3)
44	ESDI	828	10	34	—	828	137.5	Toshiba MK-156F
45	ST-506	1024	5	17	512	1023	42.5	(4)
46	ST-506	615	8	17	128	618	40.8	NEC D6147H
47								none
48	ST-506	820	6	17	—	820	40.8	Seagate ST251
49	ST-506	830	10	17	—	830	68.9	Toshiba MK56FB
50	ST-506	1024	9	17	—	1023	76.5	Seagate ST4096
51	ESDI	828	7	34	—	828	96.2	Toshiba MK-154F
52	ESDI	967	5	36	—	967	85	Seagate 94166-101
53	ESDI	967	7	36	—	967	119	Seagate 94166-141
54	ESDI	967	9	36	—	967	153	CDC 94166-182
55	ESDI	1022	7	34	—	1022	118.8	Micropolis 1354A
56	ESDI	967	5	34	—	967	80.3	Seagate 94166-101 (2)
57	ESDI	967	7	34	—	967	112.4	Seagate 94166-141 (2)

Type no.	Type	Cylinders	Heads	Sectors	Precomp	Landing zone	MB	Drive name
58	ESDI	967	9	34	—	967	144.5	Seagate 94166-182 (2)
59	AT	980	5	17	—	979	40.7	Conner CP-344 (5)
60	AT	776	8	33	—	775	100	Conner CP-3104 (5)
61	AT	745	4	28	—	744	40.7	Mini 8051A native mode
62	AT	965	5	17	—	964	40.1	Quantum 40AT
63	AT	965	10	17	—	964	80.1	Quantum 80AT
64	AT	683	16	38	—	683	200	Conner CP-3204F (5) (6)

- (1) Miniscribe 8425F, Seagate ST125
- (2) For Seagate (formerly CDC Imprima) default setting (34 sectors per track)
- (3) Micropolis 1325, Atasi 3085, Lanator Lan64, Mazdor XT1085, Newbury NDR1085
- (4) Micropolis 1323A, Miniscribe 3035, Microscience HH1050, Seagate ST4053
- (5) Epson IDE drives: 40MB (type 59), 100MB (type 60), 200MB (type 64)
- (6) The BIOS translates the actual parameters for Cylinders, Heads, and Landing zone to these values. The parameters listed in your drive's documentation may be the following: Cylinders (1366), Heads (8), and Landing zone (1365).

Hard disk drive jumper settings

Jumper positions	One hard disk drive	Two hard disk drives: master (primary)	Two hard disk drives: slave (secondary)
HS P		—	
C/D	X	X	
DSP	-	X	
ACT	X	X	X

X = jumper installed
- = no jumper installed

Note: If you install two 200MB hard disk drives, install one jumper from each drive in the two jumper positions on the master drive. Do not install any jumpers on the slave drive.

The following illustration shows the location of the jumpers on the optional Epson 200MB IDE hard disk drive.

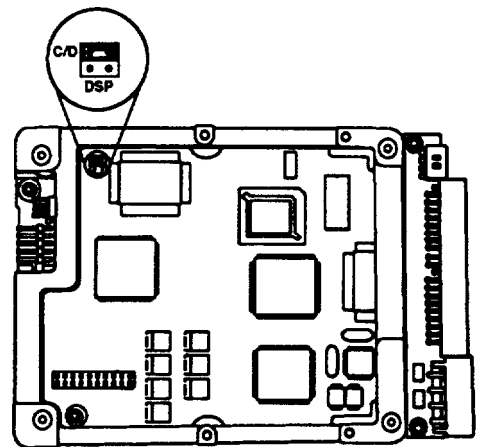

SIMM Installation

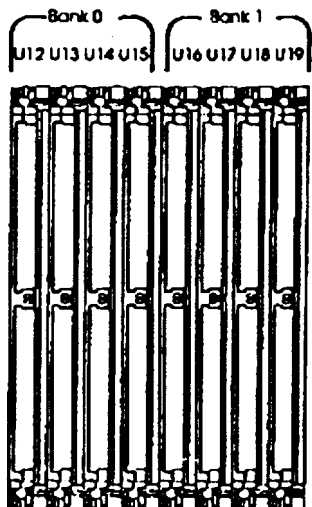

The table below describes the type of SIMMs you can install in these sockets.

SIMM description

SIMM size	Description
1MB	Single-sided (256Kbx36)
2MB	Double-sided (256Kbx36)
4MB	Single-sided (1Mbx36)
8MB	Double-sided (1Mbx36)

The table below gives examples of valid SIMM configurations you can use in your computer.

Example SIMM configurations

Bank 0				Bank 1				Total memory
U12	U13	U14	U15	U16	U17	U18	U19	
1	1	1	1	-	-	-	-	4MB*
1	1	1	1	1	1	1	1	8MB
2	2	2	2	-	-	-	-	8MB
2	2	2	2	1	1	1	1	12MB
4	4	4	4	2	2	2	2	24MB
8	8	8	8	8	8	8	8	64MB

*= Factory configuration

Error Codes and Messages

The following table lists all the error codes and messages that may appear during System diagnostic testing.

System diagnostic error codes and messages

Error code	Message
System board	
0101	CPU error
0102	ROM checksum error
0103	Timer counter register error
0104	Timer counter error
0105	Refresh error
0105	DMA controller register error
0106	DMA page register error
0107	Refresh error
0108	Keyboard controller timeout error
0108	Keyboard controller self diagnostic error
0108	Keyboard controller write command error
0109	CMOS checksum error
0110	CMOS shutdown byte error
0111	CPU instruction error
0112	CMOS battery error
0113	Interrupt controller error
0114	Protect mode error 1
0115	Protect mode error 2
Memory	
0201	Memory error
0201	Parity error
Diskette drive(s)	
0601	Diskette drive controller error
0602	Sequential seek error
0603	Random seek error
0604	Write error
0605	Read error
0606	Remove error
0607	Insert error
Coprocessor	
0701	Coprocessor not installed
0702	Coprocessor initialize error
0703	Coprocessor invalid operation mask error
0704	Coprocessor st field error
0705	Coprocessor comparison error
0706	Coprocessor zero divide mask error
0707	Coprocessor addition error
0708	Coprocessor subtraction error
0709	Coprocessor multiplication error
0710	Coprocessor precision error
Parallel port(s)	
0901	Error pin p
Serial port(s)	
1101	control signal always low
1101	control signal always high
1102	Timeout error
1103	verity error
Hard disk drive(s)	
1701	Seek error
1702	Write error
1703	Read error

EISA Series Desktop

The tables below list the possible error messages and tone codes.

Power-on diagnostic error messages

Message	Description
No timer tick interrupt	Timer tick failure
Shutdown failure	Shutdown failure
Gate A20 failure	Gate A20 failure
Unexpected interrupt in protected mode	Unexpected interrupt in protected mode
Decreasing available memory	RAM failure above address 0FFFFh
Timer chip counter 2 failed	Interval timer channel 2 failure
Time-of-day clock stopped	Time-of-day clock could not be read

Power-on diagnostic error tone codes

Error tone code	Description
1-1-3	8KB and real-time clock CMOS write/read failure
1-1-4	BIOS ROM checksum failure
1-2-1	Programmable interval timer failure
1-2-2	DMA initialization failure
1-2-3	DMA page register write/read failure
1-2-4	Invalid SIMM combination installed
1-3-0	VGA RAMDAC failure
1-3-1	RAM refresh verification failure
1-3-2	Wrong memory installation
1-3-3	First 64KB RAM chip or data line failure (multi-bit)
1-3-4	First 64KB RAM odd/even logic failure
1-4-1	First 64KB RAM address line failure
1-4-2	First 64KB RAM parity test failure
1-4-3	Fail-safe timer test failure
1-4-4	Software NMI port test failure
2-1-1	First 64KB RAM or data line failure bit 0
2-1-2	First 64KB RAM or data line failure bit 1
2-1-3	First 64KB RAM or data line failure bit 2
2-1-4	First 64KB RAM or data line failure bit 3
2-2-1	First 64KB RAM or data line failure bit 4
2-2-2	First 64KB RAM or data line failure bit 5
2-2-3	First 64KB RAM or data line failure bit 6
2-2-4	First 64KB RAM or data line failure bit 7
2-3-1	First 64KB RAM or data line failure bit 8
2-3-2	First 64KB RAM or data line failure bit 9
2-3-3	First 64KB RAM or data line failure bit A
2-3-4	First 64KB RAM or data line failure bit B
2-4-1	First 64KB RAM or data line failure bit C
2-4-2	First 64KB RAM or data line failure bit D
2-4-3	First 64KB RAM or data line failure bit E
2-4-4	First 64KB RAM or data line failure bit F
3-1-1	Slave DMA register test failure
3-1-2	Master DMA register test failure
3-1-3	Master interrupt mask register test failure
3-1-4	Slave interrupt mask register test failure
3-2-4	Keyboard controller test failure
3-3-4	Video memory test failure
3-4-1	Display initialization test failure
3-4-2	Display retrace test failure
4-2-1	Timer tick interrupt test failure
4-2-2	Shutdown test failure
4-2-3	Gate A20 failure
4-2-4	Unexpected interrupt in protected mode
4-3-1	RAM test failure above address 0FFFFh

Power-on diagnostic error tone codes

Error tone code	Description
4-3-3	Interval timer channel 2 test failure
4-3-4	Time-of-day clock test failure
4-4-1	Serial port test failure
4-4-2	Parallel port test failure
4-4-3	Coprocessor test failure

Information Reference List

Engineering Change Notices

None.

Technical Information Bulletins

None

Product Support Bulletins

None.

Related Documentation

Epson EISA Series Desktop

TM-DESKTOPT	USA Series Desktop, Service Manual Text
TM-DESKTOPC	EISA Series Desktop, Cover/Spine/Divider
PL-DESKTOP	EISA Series Desktop, Parts Price List
SPKDESKTOP	EISA Series Desktop, Self Paced Kit
Y735991001	EISA Series Desktop User's Guide