



ELECTROLUX MAJOR APPLIANCES OF NORTH AMERICA

FRIGIDAIRE
FREEZER
WITH
ELECTRONIC CONTROLS
SERVICE MANUAL

Frigidaire

TAPPAN

W White-Westinghouse

Gibson

Kelvinator 

SAFE SERVICING PRACTICES - ALL APPLIANCES

To avoid personal injury and/or property damage, it is important that **Safe Servicing Practices** be observed. The following are some limited examples of safe practices:

1. **DO NOT** attempt a product repair if you have any doubts as to your ability to complete it in a safe and satisfactory manner.
2. Before servicing or moving an appliance:
 - Remove the power cord from the electrical outlet, trip the circuit breaker to the OFF position, or remove the fuse.
 - Turn off the gas supply.
 - Turn off the water supply.
3. Never interfere with the proper operation of any safety device.
4. **USE ONLY REPLACEMENT PARTS CATALOGED FOR THIS APPLIANCE. SUBSTITUTIONS MAY DEFEAT COMPLIANCE WITH SAFETY STANDARDS SET FOR HOME APPLIANCES.**
5. **GROUNDING:** The standard color coding for safety ground wires is **GREEN**, or **GREEN** with **YELLOW STRIPES**. Ground leads are not to be used as current carrying conductors. It is **EXTREMELY** important that the service technician reestablish all safety grounds prior to completion of service. Failure to do so will create a hazard.
6. Prior to returning the product to service, ensure that:
 - All electrical connections are correct and secure
 - All electrical leads are properly dressed and secured away from sharp edges, high-temperature components, and moving parts
 - All non-insulated electrical terminals, connectors, heaters, etc. are adequately spaced away from all metal parts and panels
 - All safety grounds (both internal and external) are correctly and securely connected
 - All panels are properly and securely reassembled

ATTENTION!!!

This service manual is intended for use by persons having electrical and mechanical training and a level of knowledge of these subjects generally considered acceptable in the appliance repair trade. Electrolux Home Products cannot be responsible, nor assume any liability, for injury or damage of any kind arising from the use of this manual.

SAFE SERVICING PRACTICES	2
QUICK REFERENCE SHEET	9
Serial nameplate location	9
Chest models	9
Upright models	9
Serial number breakdown	9
Cold control location	10
Chest models	10
User interface location	10
Upright models with deluxe control	10
Chest models	10
Electronic control location (Upright models with standard control)	10
Electronic module location	11
Chest models	11
Upright models with deluxe control	11
Temperature alarm switch and indicator lights location (Upright models with standard control)	11
Deluxe control information	12
Standard control information	13
Sample wiring diagram (Chest freezer)	14
System schematic (Chest freezer)	15
Installation (Chest freezer)	15
Refrigerant charge, and electrical specifications (Chest freezer)	15
Temperature control (Chest freezer)	15
Performance (Chest freezer)	15
Thermistor resistance (Chest freezer)	15
Sample wiring diagram (Upright models with deluxe control)	16
Sample wiring diagram (Upright models with standard control)	17
Specifications (Upright Freezers)	18
Refrigerant charge and electrical	18
Defrost control	18
Temperature control (Upright models with deluxe control)	18
Performance (Upright models with deluxe control)	18
Temperature control (Upright models with standard control)	18
Performance (Upright models with standard control)	18
Thermistor resistance (Upright models with deluxe control)	18
System schematic (Upright freezer)	19
Service diagnostic (Upright models with deluxe control)	20
Air moment in upright freezers	20
SECTION A - OWNERS GUIDE	21
Product registration	21
Record your model and serial numbers	21
Register your product	21
Energy saving ideas	21
Important safety instructions	21
For your safety	21
Child safety	21
Risk of child entrapment	22
Electrical information	22
Other precautions	22
First steps	22
Installation / freezer placement	22
Leveling	23
To level upright units	23
To level chest units	23
Door removal (Upright models)	23

Lid removal (Chest models) _____	24
Setting the temperature control _____	24
Cool down period _____	24
Electromechanical temperature control (Chest and some upright models) _____	24
Standard electronic temperature control (Some upright frost free models) _____	24
Deluxe electronic temperature control (Some upright frost free models) _____	24
Freezer optional features _____	24
Power on light _____	24
Electromechanical temperature alarm (Audible only or audible with warning light) _____	24
Electronic temperature alarm (Some electronic chest models) _____	25
Electronic temperature alarm (Some electronic upright models) _____	25
Slide-out basket (Some upright models) _____	25
Security lock with pop-out key _____	25
Interior light _____	25
Adjustable shelf (Some upright models) _____	25
Slide-aside basket (Chest models) _____	25
Fast freezing shelves (Manual defrost upright models) _____	25
Tilt-out shelf (Some upright models) _____	25
Drop front (Some upright models) _____	26
Basket divider (Some upright models) _____	26
Small item shelf (Some upright models) _____	26
Pizza shelf (Some upright models) _____	26
Chest divider (Some chest models) _____	26
Examples of chest divider configurations _____	27
Compressor mounted drain pan (Most upright frost free models) _____	27
Care and cleaning _____	27
Between defrostings _____	27
Defrosting _____	27
To defrost upright models with defrost drain _____	27
To defrost chest models with defrost drain _____	27
To defrost models without defrost drain _____	28
Cleaning the inside _____	28
Cleaning the outside _____	28
Power failure / freezer failure _____	28
Risk of child entrapment _____	28
Vacation and moving tips _____	29
Short vacations _____	29
Long vacations _____	29
Moving _____	29
If a power failure occurs _____	29
Avoid service checklist _____	30
Freezer does not run _____	30
Freezer runs too much or too long _____	30
Interior freezer temperature is too cold _____	30
Interior freezer temperature is too warm _____	30
Freezer external surface temperature is warm _____	30
Louder sound levels whenever freezer is on _____	30
Louder sound levels when compressor comes on _____	30
Popping or cracking sound when compressor comes on _____	30
Bubbling or gurgling sound _____	31
Vibrating or rattling noise _____	31
Moisture forms on inside freezer walls _____	31
Moisture forms on outside freezer walls _____	31
Odors in freezer _____	31
Door/lid will not close _____	31
Light bulb is not on _____	31

Automatic icemaker not working (Some models)	31
Compact appliance warranty information	32
SECTION B - ELECTRONIC CONTROLS GUIDE	33
Temperature control	33
Temperature setting	33
Extreme freeze	33
Display lockout	33
Alarm function	34
Temperature alarm	34
Door/lid ajar alarm	34
Power failure	34
System error alarm	34
Alarm function table	34
SECTION C - ELECTRICAL OPERATION	35
Electrical mechanical control models	35
Compressor circuit	35
Alarm function circuit	35
Freezer light circuit	35
Standard electronic control models	36
Sealed system circuit	36
Defrost circuit	36
Interior light circuit	36
Power on indicator light circuit	37
Alarm circuit	37
Deluxe electronic control models	38
Electronics module and user interface circuit	38
Sealed system circuit	38
Defrost circuit	38
Interior light circuit	39
SECTION D - REFRIGERATION SYSTEM & SERVICE	40
Safety	40
Soldering	40
Refrigeration system	41
Refrigerant cycle	42
Low or high side leak or undercharge	42
Test for refrigerant leaks	42
Procedure for checking condenser leaks	43
Evacuating and recharging	43
Equipment needed for evacuation & recharging	43
Installing evacuation and recharging equipment	44
Evacuating system	44
Charging the system	44
Preparing the charging cylinder	45
Final leak test	45
SECTION E - TROUBLESHOOTING CHART (ELECTRICAL MECHANICAL CONTROL MODELS)	46
Compressor does not run	46
Compressor runs continuously, but freezer is not cold	46
Compressor runs continuously and the freezer is too cold	46
Freezer temperatures do not correspond with temperature control settings	47
Frost pattern does not cover evaporator	47
Buzzer does not sound when temperature in the freezer compartment goes above 23° F.	47
Buzzer does not turn off when temp alarm button is pushed	47
Interior light does not illuminate when door/lid is opened	47

SECTION F - TROUBLESHOOTING CHART

(STANDARD ELECTRONIC CONTROL MODELS) _____	48
Compressor and evaporator fan motor do not run _____	48
Compressor does not run, but the evaporator fan motor does _____	48
Evaporator fan motor does not run, but the compressor operates _____	48
Electronic control display does not illuminate, but the freezer operates _____	48
The electronic control does not respond when the upper or down arrows are pushed _____	48
Interior light does not glow when door is opened _____	48
Compressor runs continuously, but freezer is not cold _____	48
Compressor runs continuously and the freezer is too cold _____	49
Freezer temperatures do not correspond with temperature control settings, but the compressor operation is normal _____	49
Freezer does not automatically defrost _____	49
Power on indicator light does not glow _____	49
Temp alarm does not sound and temp light does not illuminate when the temperature in the freezer goes about 23°F. _____	49
Temp alarm light illuminates when the freezer temperature goes above 23°F, but buzzer does not sound _____	49
Temp alarm buzzer sounds when the freezer temperature goes above 23°F, but alarm light does not illuminate _____	49

SECTION G - TROUBLESHOOTING CHART

(DELUXE ELECTRONIC CONTROL MODELS) _____	50
User interface display is blank _____	50
User interface display shows “CE”. This indicating a communication error between the user interface and electronic module _____	50
Cabinet temperature is not within limits _____	50
Freezer does not go into the extreme freeze mode when the extreme freeze button is pushed _____	51
Alarms system does not operate when the temperature in the freezer goes above 23°F _____	51
Freezer interior light does not illuminate when door/lid is open _____	51
Door/lid ajar alarm does not operate _____	51
Compressor and evaporator fan motor do not run _____	51
The compressor runs, but the evaporator fan does not _____	51
The evaporator fan motor runs, but the compressor does not _____	51
Freezer does not automatically defrost _____	52

SECTION H - TEARDOWN (Upright Models) _____

Removing the wire shelves _____	53
Removing the glass shelves _____	53
Removing the lower wire basket _____	54
Removing the upper Wire basket (Some models) _____	54
Removing the upper wire basket side rails (Some models) _____	54
Removing the door shelf guard _____	55
Removing the door tilt out wire shelf _____	55
Removing the door tilt out wire shelf end cap _____	55
Removing the user interface (Deluxe control models) _____	56
Removing the kickplate _____	56
Removing the door seal _____	56
Removing the inner door liner _____	57
Removing the door handle _____	57
Removing the door lock mechanism _____	57
Removing the upper door hinge cover _____	58
Removing the upper door hinge _____	58
Removing the door _____	58
Removing the bottom door hinge and closer _____	59
Removing the air baffle _____	59

Removing the alarm switch and indicator lights bracket (Standard control models) _____	59
Removing either of the indicator lights (Standard control models) _____	60
Removing the alarm switch (Standard control models) _____	60
Removing the lights and switch bracket housing (Standard control models) _____	61
Removing the alarm buzzer (Standard control models) _____	61
Removing the light shield _____	61
Removing the light bulb _____	61
Removing the light bulb socket _____	61
Removing the alarm switch cover (Standard control models) _____	62
Removing the alarm switch (Standard control models) _____	62
Removing the evaporator cover _____	62
Removing the electronic control (Standard control models) _____	63
Removing the defrost thermostat _____	63
Removing the defrost heater _____	64
Removing the evaporator fans assembly _____	64
Removing the evaporator fans motor _____	64
Removing the evaporator fan blade _____	64
Removing the thermistor (Deluxe control models) _____	65
Removing the evaporator _____	65
Removing the door switch (Standard control models) _____	65
Removing the door switch (Deluxe control models) _____	66
Disconnecting the drain hose _____	67
Removing the drain pan _____	67
Removing the filter-drier _____	67
Removing the compressor controller _____	67
Removing the compressor _____	68
To flush the system _____	68
Using dry nitrogen to flush the system _____	68
Using refrigerant to flush the system _____	69
Installing a new compressor _____	69
Removing the electronic module (Deluxe control models) _____	70
Removing the main breakers _____	70
Removing the corner breaker _____	71
Assembling the new main breaker and (2) new corner breakers _____	71
SECTION I - TEARDOWN (Chest Models) _____	72
Removing the baskets _____	72
Removing the dividers (Some models) _____	72
Removing the interior light shield _____	72
Removing the interior light bulb _____	72
Releasing the lid _____	73
Removing lid inner liner and seal _____	73
Removing interior light socket _____	74
Removing interior light switch _____	74
Removing lid handle _____	75
Removing interface board _____	76
Removing lock latch _____	76
Removing locking mechanism _____	76
Removing outer lid panel _____	77
Removing the hinges _____	77
Removing the hinges (Alternate method) _____	78
Replacing the breaker trim _____	78
Removing the breaker trim _____	79
Removing the end caps _____	79
Removing the internal drain cap _____	79
Removing the external drain cap _____	79
Removing the cold control knob _____	80
Releasing the machine compartment cover _____	80

Removing the thermistor _____	81
Removing the electronic module _____	81
Removing the run capacitor and controller assembly _____	82
Removing the filter-drier _____	82
Replacing the compressor _____	82
To flush the system _____	83
Using dry nitrogen to flush the system _____	83
Using refrigerant to flush the system _____	83
Installing a new compressor _____	83
Replacing the condenser _____	85

QUICK REFERENCE SHEET

1. Serial nameplate location:

Chest models

On the left side of the freezer, above the machine compartment.

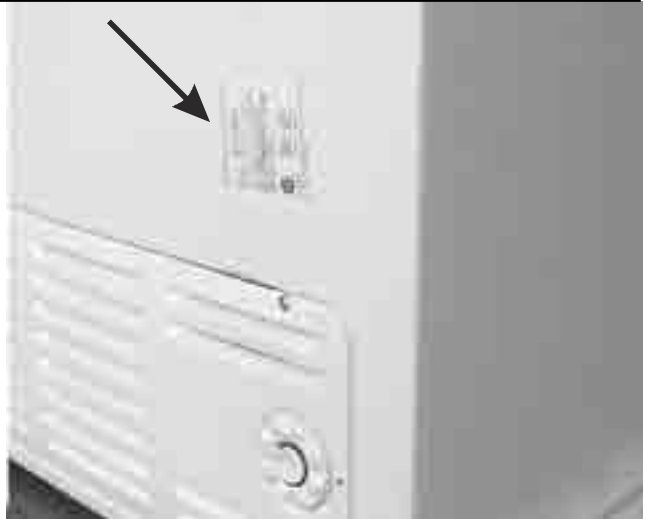

Upright models

Left-hand side of the freezer liner.



2. Serial number breakdown.

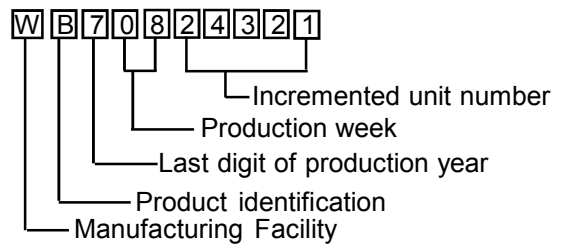

3. Cold control location:

Chest models.

Mounted to the right end of the machine compartment cover.

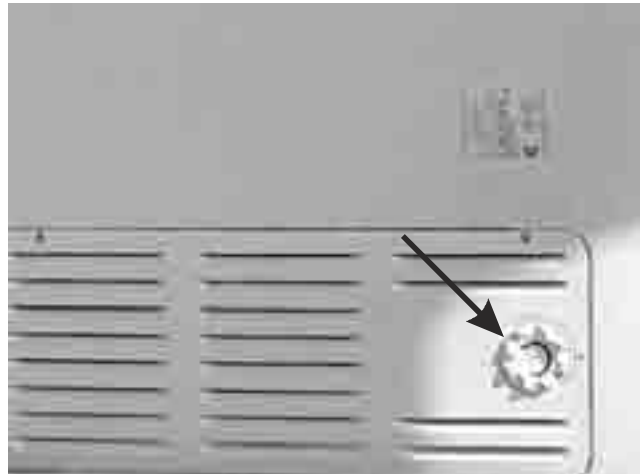

4. User interface location:

Upright freezer models with deluxe electronic control.

Top front center of the freezer door.



Chest models.

Front center of freezer lid.



5. Electronic control location:

Upright freezer models with standard electronic control.

Upper right corner of the evaporator cover.

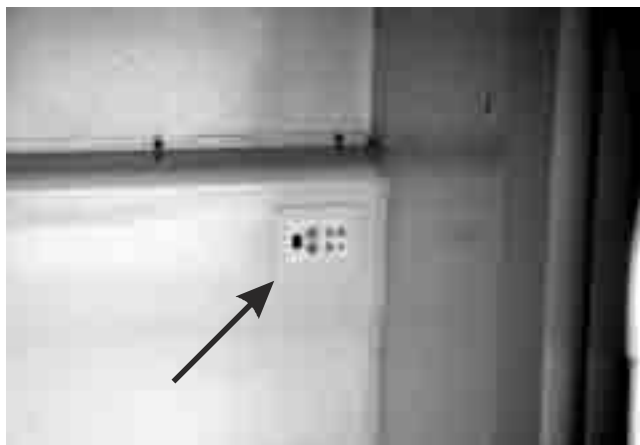

6. Electronic module location:

Chest freezer models.

Upper right corner of the rear wall of the machine compartment.

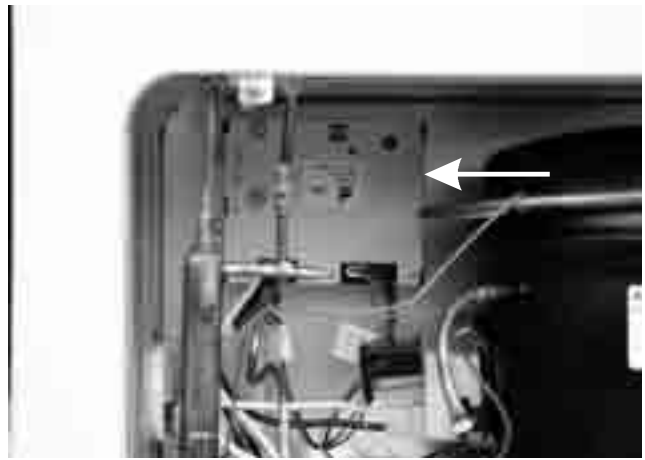

Upright freezer models with deluxe electronic control.

Top rear left corner of machine compartment.



7. Temperature alarm switch and indicator lights location:

Upright freezers with standard electronic controls.

Right side of front kick plate.

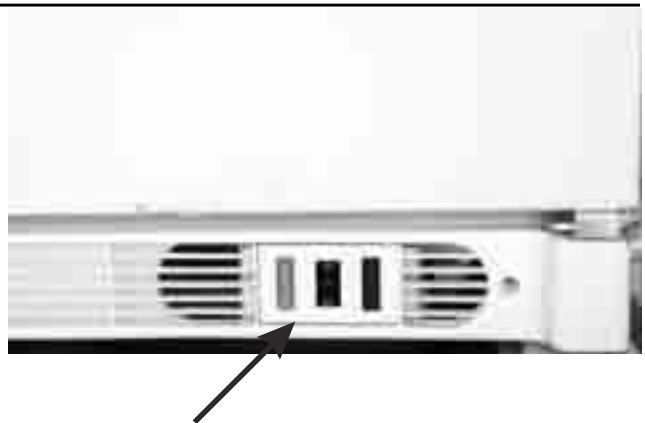

Deluxe Control Information

1. Temperature settings from 10° above zero to 10° below zero in 1° increments.
2. The control setting may be locked, to prevent accidental or unauthorized changes, by pressing and holding the alarm reset key until the control beeps. When the control is in lockout mode, if either the up or down arrows are pushed "LOC" will appear in the display. To unlock the control press and hold the alarm reset key until the control beeps and "UL" appears in the display
3. During normal operation the control displays the temperature inside the freezer in either Fahrenheit or centigrade. To change the reading from Fahrenheit to centigrade or from centigrade to Fahrenheit, press and hold the alarm reset button and the down arrow simultaneously until the control panel beeps.
4. To turn the freezer off set the control to 10° and push the up arrow. "OF" will appear in the display. With the control set to off, the freezer light will still operate, but neither the compressor or the defrost cycle will.
5. There is a 13 minute compressor off time delay built into the control.
6. To turn the control on push the down arrow. 10° will appear in the display. If the freezer is to be operated at a temperature below 10°, push the down arrow until the desired temperature is indicated on the control.
7. The control is designed to fail safe. If the control fails the compressor runs continuously with a 30 minute defrost cycle every 12 hours.
8. When the extreme freeze button is pressed, "FF" will appear in the display and the compressor will operate continuously for 72 hours or until the button is pushed again.
9. To check the thermistor set to control in the service mode, (refer to page 20) then press the temp alarm button. If "0" appears in the display the thermistor is open. If "C" appears in the displays the thermistor is shorted. If a "-" appears in the display the thermistor is good.
10. If the cabinet temperature rises to the level above 23°F. the high temperature alarm will activate. The control panel will beep every five seconds, the red alarm light will glow and the display will flash. This will continue until the temperature level drops below 23°F. To stop the beeping press the alarm reset button, to stop the display from flashing press and hold the alarm reset button.
11. An automatic 30 minute defrost cycle will occur every 12 hours of compressor run time.
12. To manually defrost the freezer, press and hold the extreme freeze and the temperature alarm buttons simultaneously for 10 seconds or more. A half second beep will sound and "df" will appear in the display for 3 seconds indicating the control has entered into the 30 minute defrost cycle. At the end of the defrost cycle the control will then restart its 12 hour compressor run time count for the next automatic defrost cycle.
13. If the door is left ajar for more than five minutes, the door alarms is activated. The control panel will beep every five seconds, the red alarm light will glow and the display will alternate between "d" and the cabinet temperature. Press the alarm reset button to turn off the audible alarm. The display will keep flashing and the red light will stay on. Close the door of the freezer to return it to normal operation.

Standard Control Information

1. Temperature settings from 1 to 7. For corresponding temperatures see the chart below.

Set points	Base Temperature °F.
0	OFF
1	10
2	6.6
3	3.3
4	0
5	- 3.3
6	- 6.6
7	- 10

2. To turn the freezer off set the control to 1 and push the up arrow (3) times. "O" will appear in the display indicating the control is in the off position. With the control set to off, the freezer light will still operate, but neither the compressor or the defrost cycle will.
3. There is a 13 minute compressor off time delay built into the control.
4. To turn the control on push the down arrow 3 times. "1" will appear in the display. If the freezer is to be operated at a setting temperature below 1, push the down arrow until the desired number is indicated on the control.
5. The control is designed to fail safe. If the control fails the compressor runs continuously with a 30 minute defrost cycle every 12 hours.
6. To check the thermistor set to control to "4" then press both the up and down arrow at the same time for 3 seconds to initiate the service mode. If "O" appears in the display the thermistor is open. If "C" appears in the displays the thermistor is shorted. If a "-" appears in the display the thermistor is good.
7. An automatic 30 minute defrost cycle will occur every 12 hours of compressor run time.
8. To manually defrost the freezer set the control to "2" and press the up and down arrows simultaneously for three seconds. "d" will appear in the display and a 30 minute defrost will occur. The control will then restart its 12 hour compressor run time for the next automatic defrost cycle.

Chest Freezer Sample Wiring Diagram

always refer to diagram with product

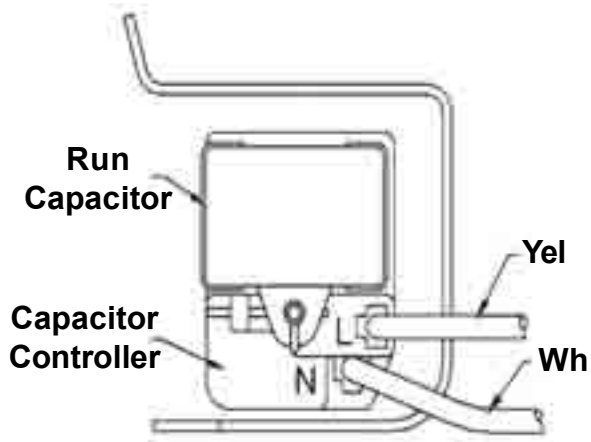
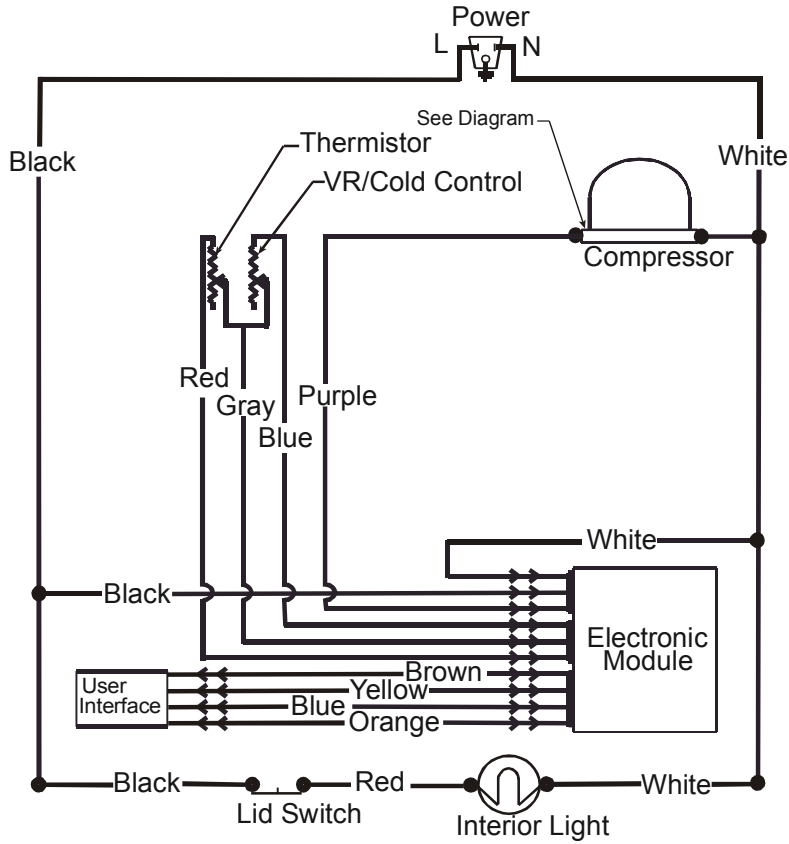

IMPORTANT
 IF ANY GREEN GROUNDING WIRES ARE REMOVED DURING SERVICING, THEY MUST BE RETURNED TO THEIR ORIGINAL POSITION AND PROPERLY SECURED.

Chest freezer systems schematic

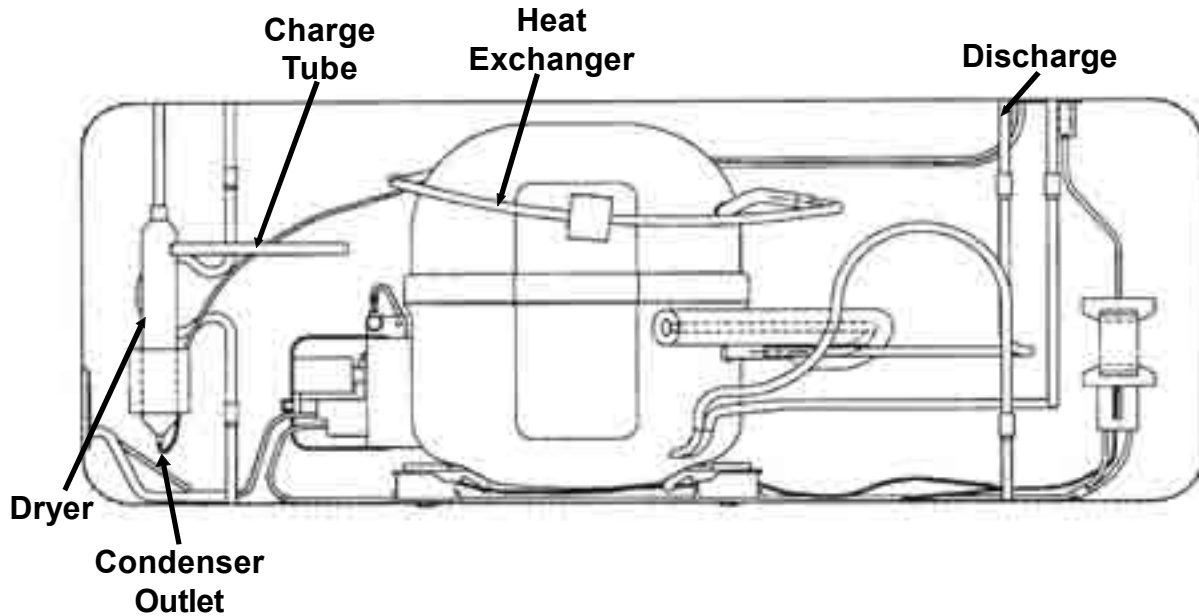

INSTALLATION (Chest freezer)

This product is designed for "free standing installation only" and three inches of clearance must be provided on all sides of the freezer for air circulation.

The floor or mounting surface should be level and capable of supporting the weight of the freezer when it is fully loaded.

REFRIGERANT CHARGE AND ELECTRICAL SPECIFICATIONS (Chest freezer)

Refer to serial plate.

TEMPERATURE CONTROL (Chest freezer)

14.0°F cut in, 0°F cut-out @ number 1 setting.

PERFORMANCE (Chest freezer)

(Control at number 1 setting)

Room Ambient	70°F	90°F
Freezer Compartment Temperature	5 to 12°F	5 to 12°F
Percent Running Time	30-40%	45-55%
*Wattage Range (Last 1/3 of cycle)	100-140	110-145
Suction Pressure (Cut-in, cut-out), PSIG	15-0	15-0
High Side Pressure (Last 1/3 of cycle), PSIG	105-125	155-165

THERMISTOR RESISTANCE (Chest freezer)

10K at 77° F., and 32.6 K. at 32° F.

Upright Freezer with Deluxe Electronic Control

Sample Wiring Diagram always refer to diagram with product

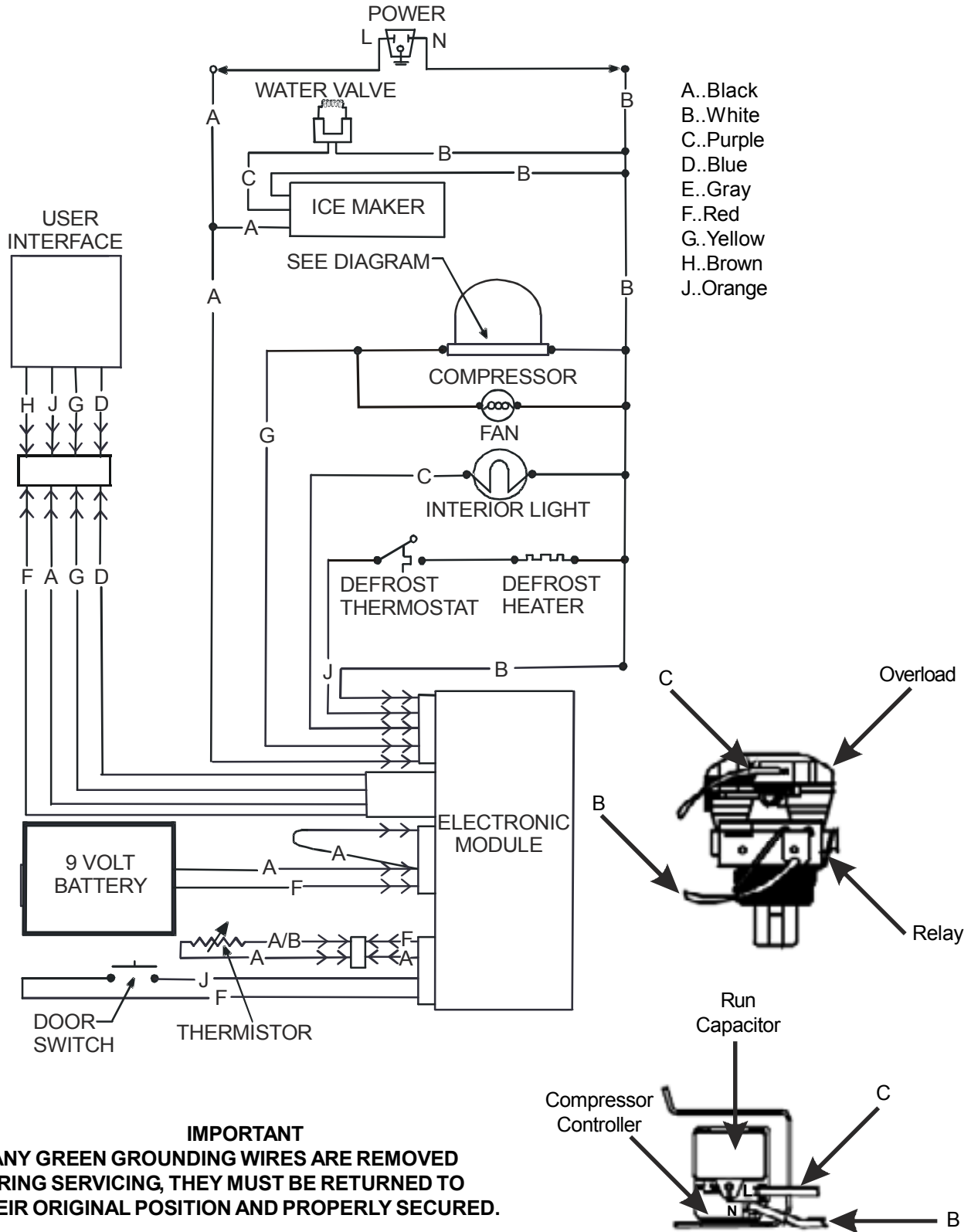

IMPORTANT
IF ANY GREEN GROUNDING WIRES ARE REMOVED
DURING SERVICING, THEY MUST BE RETURNED TO
THEIR ORIGINAL POSITION AND PROPERLY SECURED.

Upright Freezer with Standard Electronic Control

Sample Wiring Diagram always refer to diagram with product

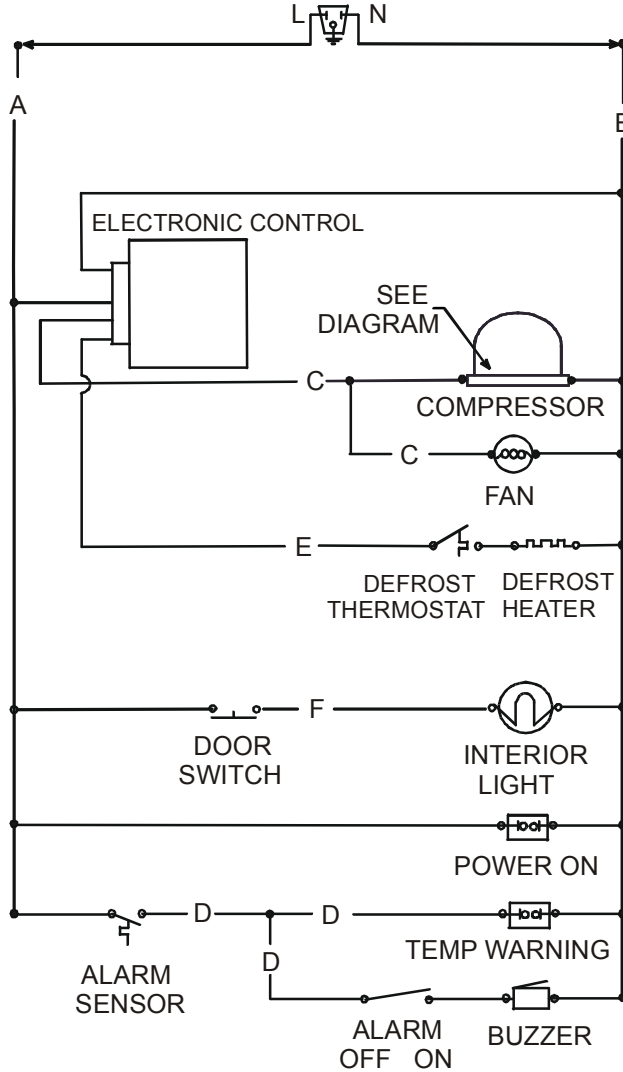

- A..Black
- B..White
- C..Yellow
- D..Red
- E..Orange
- F..Brown

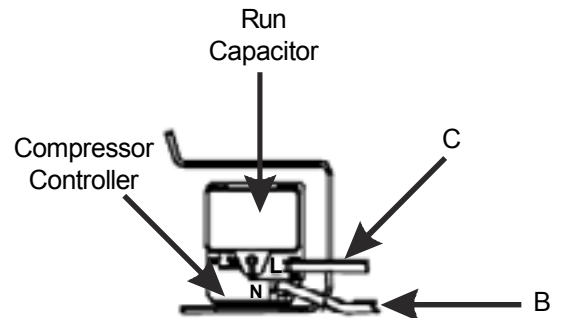
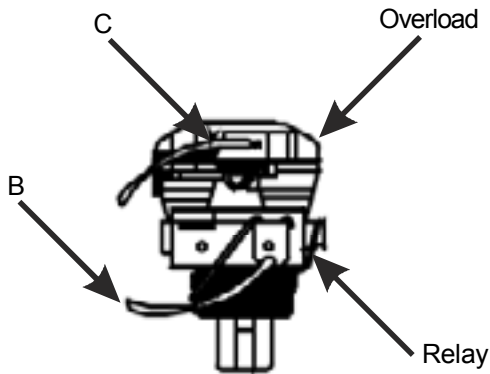

IMPORTANT

IF ANY GREEN GROUNDING WIRES ARE REMOVED DURING SERVICING, THEY MUST BE RETURNED TO THEIR ORIGINAL POSITION AND PROPERLY SECURED.

SPECIFICATIONS (Upright Freezers)

REFRIGERANT CHARGE AND ELECTRICAL

Refer to serial plate.

DEFROST CONTROL

An automatic 30 minute defrosting period is initiated after every 12 hours of compressor running time. During the defrosting period a thermostat will switch the defrost heater off after the frost on the evaporator has melted. The defrost thermostat closes at 10°F and opens at 50°F.

Upright Freezers with Deluxe Electronic Control

TEMPERATURE CONTROL

4.0°F cut in, -10°F cut-out @ number 1 setting.

PERFORMANCE

(Control at number 1 setting)

Room Ambient	70°F	90°F
Freezer Compartment Temperature	2 to 8°F	2 to 8°F
Percent Running Time	35 - 45%	50 - 65%
*Wattage Range (Last 1/3 of cycle)	115 - 140	120 - 145
Suction Pressure (Cut-in, cut-out), PSIG	14 - 0	14 - 0
High Side Pressure (Last 1/3 of cycle), PSIG	100 - 115	140 - 155

Upright Freezers with Standard Electronic Control

TEMPERATURE CONTROL

4.0°F cut in, -10°F cut-out @ number 1 setting.

PERFORMANCE

(Control at number 1 setting)

Room Ambient	70°F	90°F
Freezer Compartment Temperature	2 to 12°F	2 to 12°F
Percent Running Time	30 - 45%	45 - 65%
*Wattage Range (Last 1/3 of cycle)	100 - 140	110 - 145
Suction Pressure (Cut-in, cut-out), PSIG	14 - 0	14 - 0
High Side Pressure (Last 1/3 of cycle), PSIG	100 - 125	140 - 165

THERMISTOR RESISTANCE (Upright freezers Deluxe Electronic Control)

10K at 77° F., and 32.6 K. at 32° F.

UPRIGHT FREEZER SYSTEM SCHEMATIC

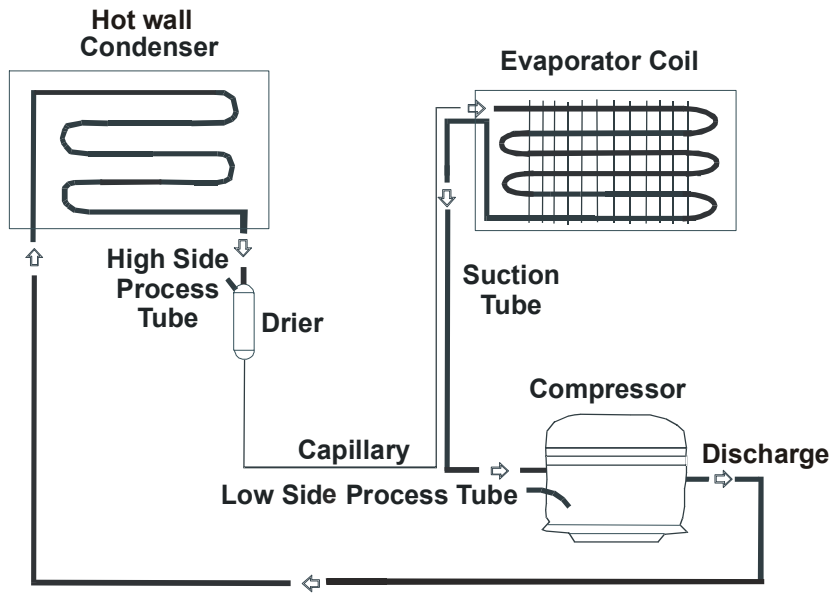

Service Diagnostic on Models with Deluxe Electronic Controls

Initiate Service Mode

1. Set the temperature to 0°F, then press and hold both the up and down arrows simultaneously for 5 seconds.
2. When the diagnostics mode is entered, the number "88" is displayed and an audible chirp is sounded. The status information will be displayed for 3 seconds and then return to the diagnostics indicator.
3. To check the door switch contacts, press the down arrow. If the freezer door is open, the letter "O" will appear in the display indicating that the freezer the door is open and the door switch contact are closed. If the freezer door is closed, the letter "C" will appear in the display indicating the door is closed and the door switch contacts are open.
4. To check the thermistor, press the temp alarm button. If the thermistor is operating properly "--" will appear in the display. If the thermistor is shorted, "S" will appear in the display. If the thermistor is open, "O" will appear in the display.

Note: A defective thermistor will cause the compressor to run continuously.

5. To exit the service mode, press and hold the up and down arrows simultaneously for five seconds or more.

Air Moment in Upright Freezers

Air is pulled in through the bottom of the evaporator cover

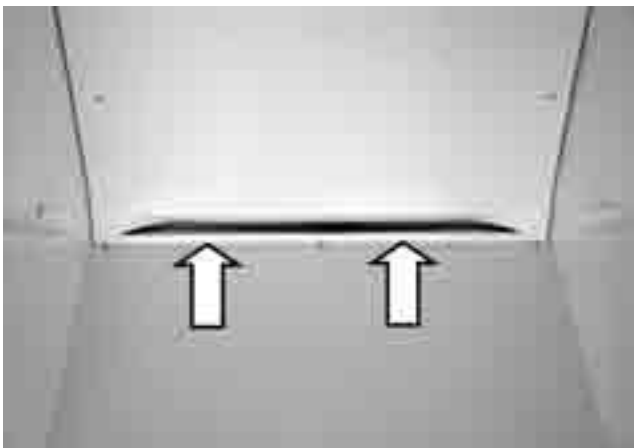

and across the evaporator by the evaporator fan.

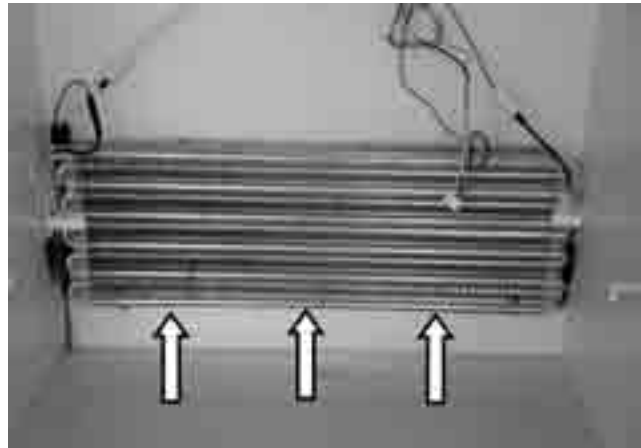

The fans then pushes the air up the channel behind the liner

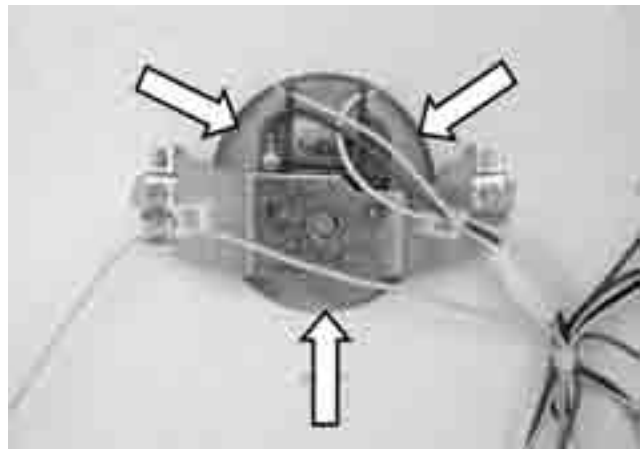

and out the openings in the top rear of the freezer liner.

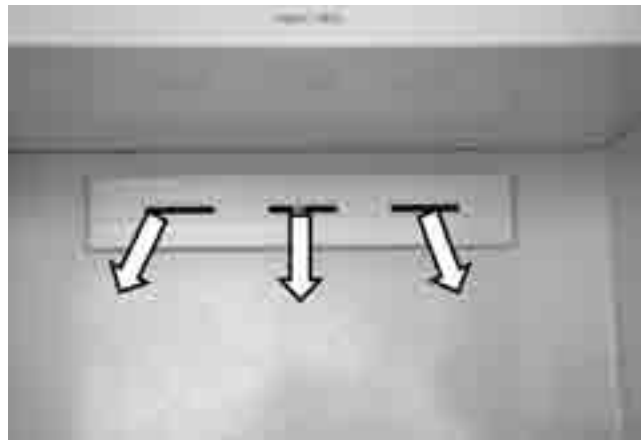

SECTION A - OWNERS GUIDE

Product Registration



Versión en español

Si desea obtener una copia en español de este Manual del Usuario, sírvase escribir a la dirección que se incluye a continuación. Solicite la P/N 297079300.

Spanish Owner's Guides
Electrolux Home Products
P.O. Box 212378
Augusta, GA 30917

The information contained in this Use and Care Guide will instruct you on how to properly operate and care for your product. Please read through the information contained in your literature pack to learn more about your new freezer.

Record your Model and Serial Numbers

Record the model number and serial number of this freezer in the space provided below.

Model No. _____

Serial No. _____

Register Your Product

The self-addressed PRODUCT REGISTRATION CARD (shown above) should be filled in completely, signed and returned to Electrolux Home Products.

This Use and Care Guide provides operating instructions for your model. Use your freezer only as instructed in this Use and Care Guide.

Energy Saving Ideas



- The freezer should be located in the coolest area of the room, away from heat producing appliances or heating ducts, and out of direct sunlight.
- Let hot foods cool to room temperature before placing in the freezer. Overloading the freezer forces the compressor to run longer. Foods that freeze too slowly may lose quality or spoil.
- Be sure to wrap foods properly and wipe containers dry before placing them in the freezer. This cuts down on frost build-up inside the freezer.
- Freezer shelves and baskets should not be lined with aluminum foil, wax paper, or paper toweling. Liners interfere with cold air circulation, making the freezer less efficient.
- Organize and label food to reduce door/lid openings and extended searches. Remove as many items as needed at one time, and close door/lid as soon as possible.

Important Safety Instructions

Read all instructions before using this freezer.

⚠ WARNING For your safety

Do not store or use gasoline or other flammable vapors and liquids in the vicinity of this unit or any other appliance. Read product labels for flammability and other warnings.

⚠ WARNING Child Safety

- Destroy carton, plastic bags, and any exterior wrapping material immediately after the freezer is unpacked. Children should never use these items for play. Cartons covered with rugs, bedspreads, plastic sheets or stretch wrap may become airtight chambers and can quickly cause suffocation.

- A child might suffocate if he crawls into the freezer to hide or play. Remove the door/lid of the freezer when not in use, even if you plan to discard the freezer. Many communities have laws requiring you to take this safety precaution.
- Remove or discard any spacers used to secure the shelves during shipping. Small objects are a choke hazard to children.

⚠ WARNING Risk of Child Entrapment

Child entrapment and suffocation are not problems of the past. Junked or abandoned refrigerators or freezers are still dangerous – even if they will sit for “just a few days”. If you are getting rid of your old refrigerator or freezer, please follow the instructions below to help prevent accidents:

- Remove the door/lid.
- Leave shelves in place so children may not easily climb inside.
- Have the refrigerant removed by a qualified technician.

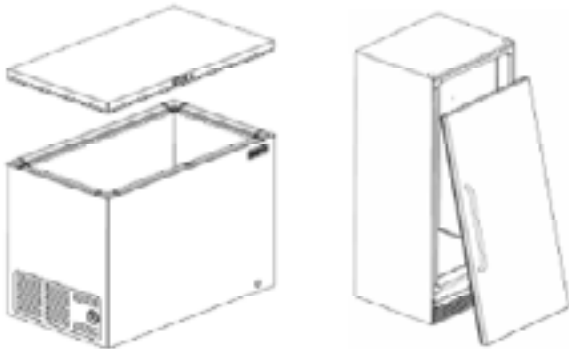

⚠ WARNING Electrical Information

These guidelines must be followed to ensure that safety mechanisms in the design of this freezer will operate properly.

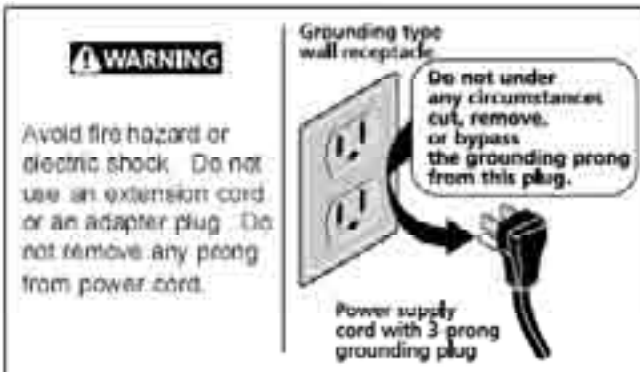

- Refer to the serial plate for correct electrical rating. The power cord of the freezer is equipped with a three-prong grounding plug for protection against shock hazards. It must be plugged directly into its own properly grounded three-prong receptacle, protected with a 15 amp time delay fuse or circuit breaker. The receptacle must be installed in accordance with the local codes and ordinances. Consult a qualified electrician. Receptacles with Ground Fault Circuit Interrupters (GFCI) are **NOT RECOMMENDED. DO NOT USE AN EXTENSION CORD OR AN ADAPTER PLUG.**

- If the voltage varies by 10 percent or more, freezer performance may be affected. Operating the freezer with insufficient power can damage the motor. Such damage is not covered under the warranty. If you suspect your voltage is high or low, consult your power company for testing.
- To prevent the freezer from being turned off accidentally, do not plug the unit into an outlet controlled by a wall switch or pull cord.
- Do not pinch, knot, or bend the power cord in any manner.

⚠ WARNING Other Precautions

- To defrost, always unplug unit first.
- Never unplug the freezer by pulling on the power cord. Always grip the plug firmly and pull straight out from the receptacle.
- Turning the control to “OFF” turns off the compressor but does not disconnect power to other electrical components.

First Steps

Before starting the freezer, follow these important first steps.

Installation / Freezer Placement

- Choose a place that is near a grounded electrical outlet.
- The freezer should be located where surrounding temperature will not exceed 110°F (43°C). Temperatures of 32°F (0°C) and below will NOT affect freezer operation. Additional compressor heaters are not recommended.
- Allow space around the unit for good air circulation. Leave a 3 inch (75mm) space on all sides of the freezer for adequate circulation.

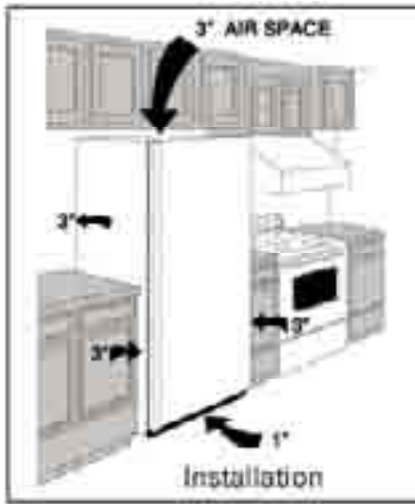

Leveling

The freezer must have all bottom corners resting firmly on a solid floor. The floor must be strong enough to support a fully loaded freezer. It is VERY IMPORTANT for your freezer to be level in order to function properly. If the freezer is not leveled during installation, the door/lid may be misaligned and not close or seal properly, causing cooling, frost or moisture problems.

To level Upright Units:

After discarding crating screws and wood base, use a carpenter's level to level the freezer from front to back. Adjust the plastic leveling feet in front, ½ bubble higher, so that the door closes easily when left halfway open.

To level Chest Units:

If needed, add metal or wood shims between feet pads and floor.

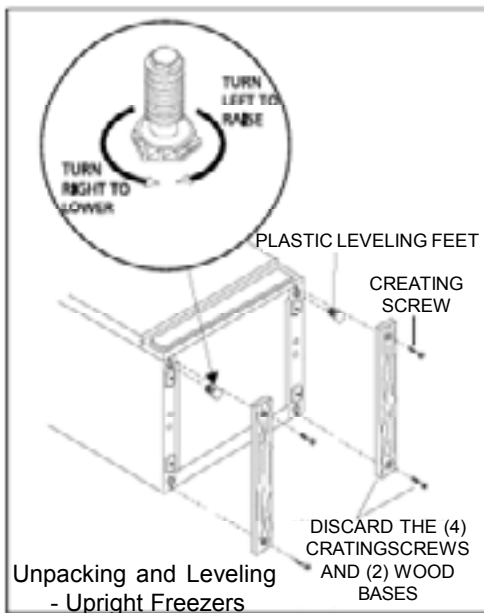

Door Removal (Upright Models)

- Unplug the unit.
- Gently lay freezer on its back, on a rug or blanket.
- Remove two base screws and base panel. Remove wire from clips on bottom of cabinet, if required.
- Unplug connector, if required, by holding the cabinet connector in place and pulling the door connector out.
- Remove the bottom hinge screws.
- Remove the plastic top hinge cover.
- Remove the screws from the top hinge.
- Remove the top hinge from the cabinet.
- Remove the door and bottom hinge from the cabinet.
- To replace door, reverse the above procedures and securely tighten all screws to prevent hinge slippage.

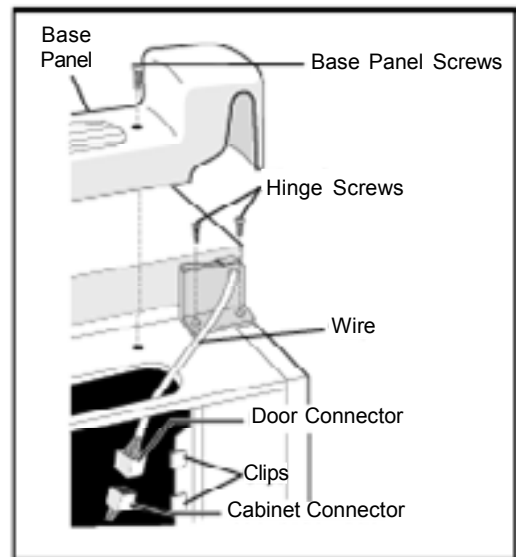

Lid Removal (Chest Models)

- See lid removal instructions on the back of the cabinet.

Setting the Temperature Control

Cool Down Period

- For safe food storage, allow four (4) hours for freezer to cool down completely. The freezer will run continuously for the first several hours. Foods that are already frozen may be placed in the freezer after the first few hours of operation. Unfrozen foods should NOT be loaded into the freezer until freezer has operated for four (4) hours.
- When loading freezer, freeze only three (3) pounds of fresh food per cubic foot of freezer space at one time. Distribute packages to be frozen evenly throughout the freezer. It is not necessary to turn the control knob to a colder setting while freezing food.

Electromechanical Temperature Control (Chest and Some Upright Models)

The electromechanical temperature control is located inside the freezer on upright models, and on the left exterior wall on chest models (see figure 1). The temperature is factory preset to provide satisfactory food storage temperatures. However, the temperature control is adjustable to provide a range of temperatures for your personal satisfaction. To adjust the temperature setting, turn the temperature control knob clockwise or counter clockwise. Allow several hours for the temperature to stabilize between adjustments.



Electromechanical Control
Figure 1

Standard Electronic Temperature Control (Some Upright Frost Free Models)

The standard electronic temperature control is located inside the freezer on upright models (see Figure 2). Temperature is factory preset to provide satisfactory food storage temperatures. To adjust the temperature setting, move the UP (▲) button for warmer temperature and DOWN (▼) button for colder temperature on the control panel. Allow several hours for the temperature to stabilize between adjustments.

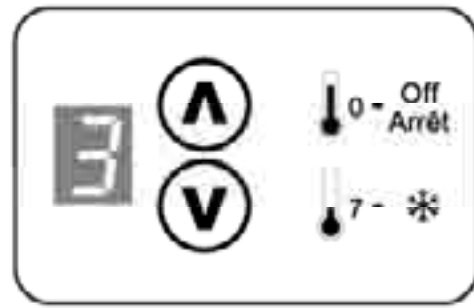

Standard Electronic Temperature Control
Figure 2

Deluxe Electronic Temperature Control (Some Upright Frost Free Models)

Refer to the Electronics Control Guide supplied when you purchase a deluxe electronic upright model. See Figure 3 for deluxe electronics control panel.



Deluxe Electronic Temperature Control
Figure 3

Freezer Optional Features

Your freezer may have some or all of the features listed below. Become familiar with these features and their use and care.

Power On Light

The power on light indicates that the freezer is properly connected to an electrical power. The light glows even when the temperature control is turned to "OFF". If the light goes out, refer to "Freezer does not run" in the Avoid Service Checklist section.

Electromechanical Temperature Alarm (Audible Only or Audible with Warning Light)

This feature is designed to provide a warning of a possible malfunction. If the temperature of the food rises to a level unsafe for long-term storage, the buzzer will sound. The red light, if equipped, will also glow. The Temp Alarm feature operates on household electricity. If power fails, the alarm will not function. An ON/OFF switch allows you to deactivate the Temp Alarm when not wanted. The freezer is shipped with the Temp Alarm in the "OFF" position (if equipped). After the freezer has run approximately four (4) hours, the red light, if equipped, will go off. Then you may activate the Temp Alarm without the alarm sounding.

Press the "ON" switch to activate the Temp Alarm feature. To deactivate, press the "OFF" switch.

If the alarm sounds, be sure freezer is properly leveled, and the door/lid closes freely and seals properly. If you suspect a technical malfunction, call an authorized service personnel immediately.

Electronic Temperature Alarm (Some Electronic Chest Models)

This feature is designed to provide a warning if the inside temperature reaches an unsafe level. The Temp Alarm feature operates on household electricity. It will not function if household electricity is interrupted.

When the freezer is initially plugged in, the red Temp Alarm indicator light blinks. The indicator light will continue to blink until the freezer has reached a safe freezing temperature. If a malfunction causes an unsafe temperature inside the freezer, the red light will blink and the buzzer will sound. To silence the buzzer, press the ALARM OFF button. The indicator light will continue to blink until a safe freezing temperature is again reached. If the problem is not solved within twelve (12) hours, the buzzer will turn on again. If the ALARM OFF button is not pressed, the buzzer will turn itself off automatically after 48 hours, but the red Temp Alarm light will continue to blink.

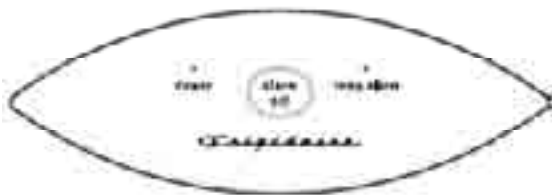

Electronic Temperature Alarm (Some Electronic Upright Models)

Refer to the Electronics Control Guide supplied when you purchase a deluxe electronic upright model.



Slide-Out Basket (Some Upright Models)

The slide-out basket, located at the bottom of the freezer provides separate storage space for items that are difficult to store on freezer shelves. To remove the basket, pull out and lift up.

Security Lock with Pop-out Key

This security lock fastens the door/lid snugly, ensuring that stored food is secure. To lock or unlock the freezer, push the key into the lock and turn. The key pops out of the lock after it has been turned.

Interior Light

The light comes on automatically when the door/lid is opened. To replace the light bulb, turn the temperature control to "OFF" and unplug the electrical cord. Replace the old bulb with a bulb of the same type and wattage.

Adjustable Shelf (Some Upright Models)

This shelf can be moved to one of two positions. Lift the shelf up and out to move to the desired position.

Slide-Aside Basket (Chest Models)

This basket helps organize odd-shaped items. To reach other packages in the freezer, slide the basket aside or lift out.

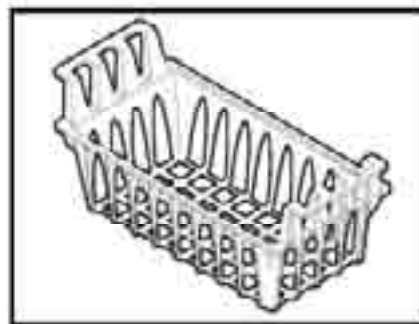

Fast Freezing Shelves (Manual Defrost Upright Models)

These shelves contain cooling coils to freeze foods quickly and allow cold air to constantly circulate throughout the freezer. Do not use sharp metal objects such as ice picks or scrapers to clean the shelves. This could damage the shelves and reduce their cooling ability. These shelves are not adjustable.

Tilt-Out Shelf (Some Upright Models)

This shelf is located inside on the freezer door and provides additional storage space. To access an item, tilt the top of the "basket" shelf down.

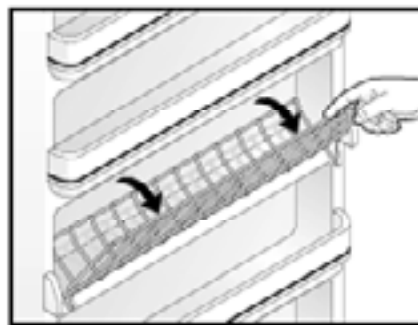

Tilt-Out Shelf

Drop Front (Some Upright Models)

The drop front, located at the bottom of the freezer, provides a separate compartment for small irregular shaped items. Lift the front up and out to remove.

Basket Divider (Some Upright Models)

Use these handy dividers to keep the various items stored in your baskets more organized. To change the location of the divider simply slide your basket out, lift up on each end of the divider until it is disengaged from the basket, place divider in the desired location (make sure it is between two vertical wires) and press down firmly on each end until it snaps into place.

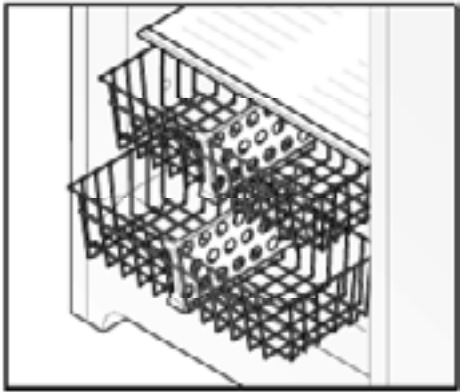

Small Item Shelf (Some Upright Models)

Use this shelf to store several of your single-serving microwavable dinners or other small items that you want to keep in an easy-to-reach spot.

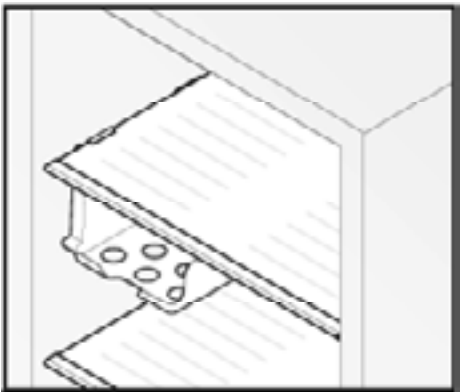

Pizza Shelf (Some Upright Models)

Here is the place to store up to four extra-large boxes of frozen pizza without ever having to dig them out from beneath a pile of other stored goods. To change the location of the pizza shelf: support the bottom center of the shelf with one hand and use your other hand to gently ease each support tab outward until they have all dropped between the edge of the shelf and the liner wall. It may help to slide the supporting shelf slightly to the side opposite that in which you are removing the tabs in

order to get a larger gap between the edge of the supporting shelf and the liner wall.

Next, locate the pizza shelf beneath the shelf nearest your desired location and snap each tab upwards between the wire or glass shelf and liner until the tab has snapped into place and is resting on top of the supporting shelf. Repeat for each tab until all four are firmly in place and then load with desired items.

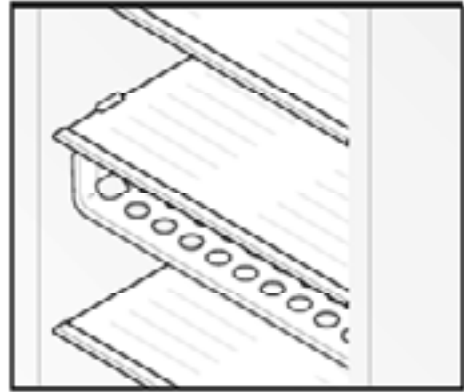

Chest Divider (Some Chest Models)

Use these clever dividers to custom-arrange a variety of different sized storage bins in the bottom of your chest freezer. Use the peel-n-stick labels found in your literature packet to help remind you which items are stored where. If you have an item that isn't already covered by one of the pre-printed labels then use one of the blank labels and a permanent marking pen to make your own custom label. Labels can be peeled off when no longer needed and replaced by new and different ones.

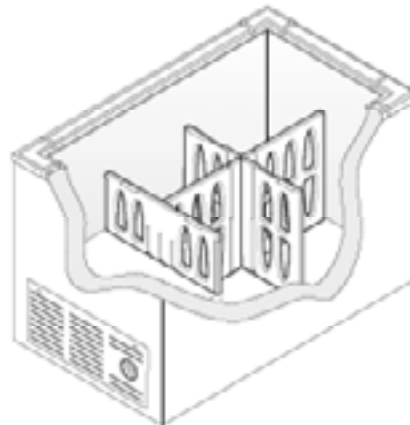

Examples of Chest Divider Configurations:

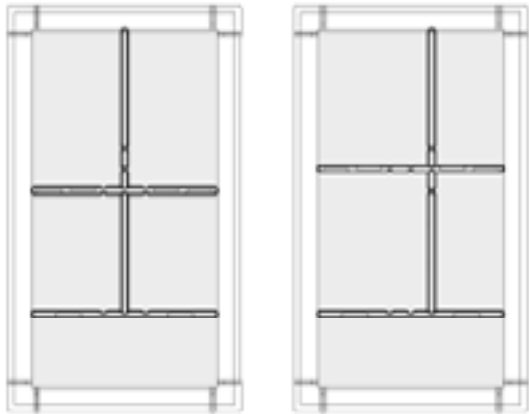

Compressor Mounted Drain Pan (Most Upright Frost Free Models)

Most upright frost free freezers are equipped with a compressor mounted drain pan that collects condensate during each defrost cycle. This compressor mounted drain pan takes advantage of the heat generated by the compressor to evaporate condensate water so there is no need to empty the pan during each defrost cycle.

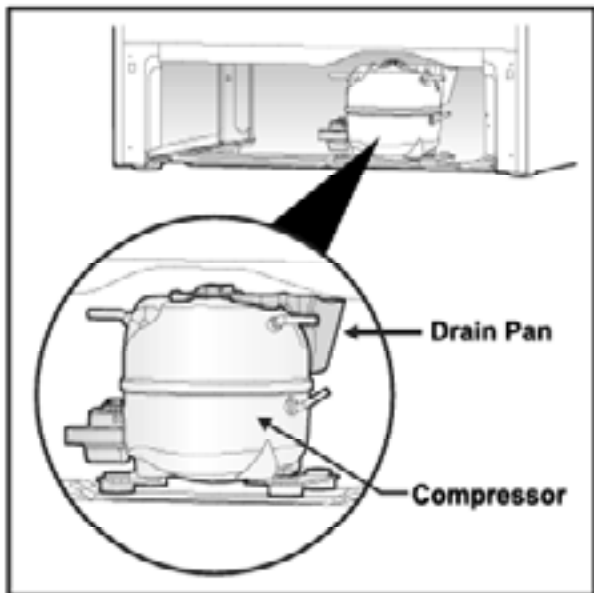

Care and Cleaning

- Damp objects stick to cold metal surfaces. DO NOT touch interior metal surfaces with wet or damp hands.
- The freezer must be unplugged (to avoid electrical hazard) from power source when defrosting the unit.

Some upright and chest freezers are frost free and

defrost automatically, but should be cleaned occasionally.

Between Defrostings

To avoid frequent defrosting, occasionally use a plastic scraper to remove frost. Scrape with pulling motion. NEVER use a metal instrument to remove frost.

Defrosting

It is important to defrost and clean the freezer when $\frac{1}{4}$ to $\frac{1}{2}$ inch of frost has accumulated. Frost may tend to accumulate faster on the upper part of the freezer due to warm, moist air entering the freezer when the door/lid is opened. Remove food and leave the door/lid open when defrosting the freezer.

To Defrost Upright Models with Defrost Drain:

- Remove the drain plug on the inside floor of the freezer by pulling it straight out.
- To access external drain tube on models with a base panel, first remove the two screws from the base panel. Locate the drain tube near the left center under the freezer.
- Place a shallow pan under the drain tube. Defrost water will drain out. Check the pan occasionally so water does not overflow (see figure 1).

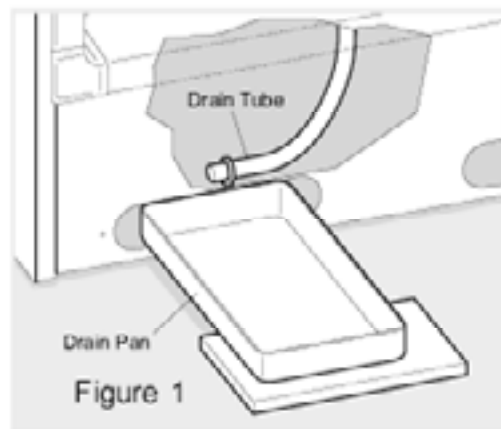

- A $\frac{1}{2}$ inch garden hose adapter can be used to drain the freezer directly into a floor drain. If your model is not equipped with an adapter, one can be purchased at most hardware stores.
- Replace the drain plug when defrosting and cleaning are completed. If the drain is left open, warm air may enter the freezer.

To Defrost Chest Models with Defrost Drain:

- Place a shallow pan or the Divider/Drain Pan (if equipped) beneath the drain outlet. Pull out the outside

drain plug (see figure 2).

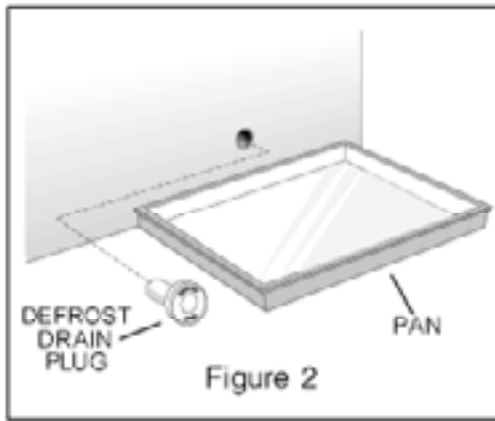

A ½ inch garden hose adaptor can be used to drain the freezer directly into a floor drain (see figure 3).

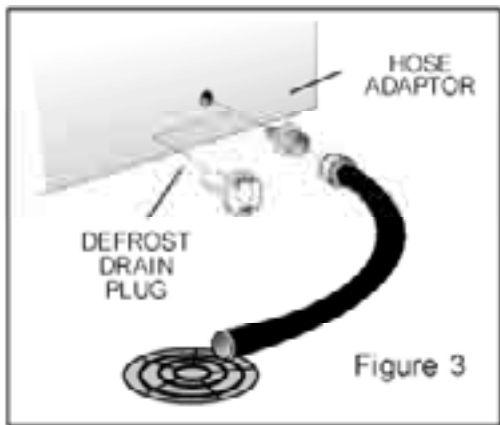

If your model is not equipped with an adaptor, one can be purchased at most hardware stores.

- Pull out the drain plug inside the freezer (see figure 4).

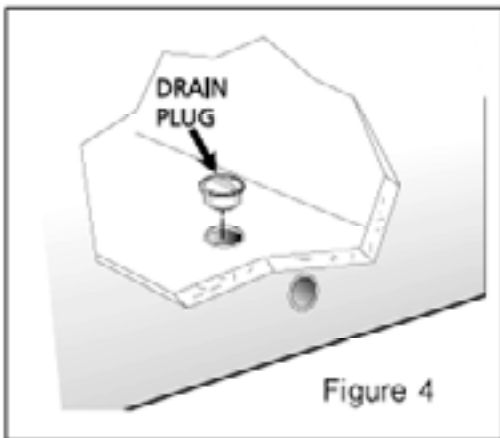

Defrost water will drain out. Check pan occasionally so water does not overflow.

- Replace the drain plugs when defrosting and cleaning are completed. If the drain is left open, warm air may enter the freezer.

To Defrost Models without Defrost Drain:

- Place towels or newspapers on the freezer bottom to catch the frost. The frost will loosen and fall.
- Remove the towels and/or newspapers.
- If the frost is soft, remove it by using a plastic scraper. If the frost is glazed and hard, fill deep pans with hot water and place them on the freezer bottom.
- Close the freezer door/lid. Frost should soften in about fifteen (15) minutes.
- Repeat this procedure is necessary.

Cleaning The Inside

After defrosting, wash inside surfaces of the freezer with a solution of two (2) tablespoons of baking soda in one (1) quart (1.136 liters) warm water. Rinse and dry. Wring excess water out of the sponge or cloth when cleaning in the area of the controls, or any electrical parts.

Wash the removable parts with the baking soda solution mentioned above, or mild detergent and warm water. Rinse and dry. NEVER use metallic scouring pads, brushes, abrasive cleaners or alkaline solutions on any surface. DO NOT wash removable parts in a dishwasher.

Cleaning The Outside

Wash the cabinet with warm water and mild liquid detergent. Rinse well and wipe dry with a clean soft cloth. Replace parts and food.

Do not use razor blades or other sharp instruments, which can scratch the freezer surface when removing adhesive labels. Any glue left from the tape can be removed with a mixture of warm water and mild detergent, or touch the residue with the sticky side of the tape already removed. DO NOT REMOVE THE SERIAL PLATE.

Power Failure / Freezer Failure

⚠ WARNING Risk of Child Entrapment

If leaving the freezer door/lid open while on vacation, make certain that children cannot get into the freezer and become entrapped. DO NOT open freezer door/lid unnecessarily if freezer is off for several hours.

Vacation and Moving Tips

Short Vacations:

- Leave the freezer operating during periods of non-use of less than three (3) weeks.

Long Vacations:

If the freezer will not be used for several months:

- Remove all food and unplug the power cord.
- Clean and dry the interior thoroughly.
- Leave the freezer door/lid open slightly, blocking it open if necessary, to prevent odor and mold growth.

Moving:

When moving the freezer, follow these guidelines to prevent damage:

- Disconnect the power cord plug from the wall outlet.
- Remove foods, then defrost, and clean the freezer.
- Secure all loose items such as base panel, baskets, and shelves by taping them securely in place to prevent damage.
- In the moving vehicle, secure freezer in an upright position to prevent movement. Also, protect outside of freezer with a blanket or similar item.

IF A POWER FAILURE OCCURS:

Frozen foods will stay frozen for at least 24 hours if the freezer is kept closed. If the power failure continues, pack seven or eight pounds of dry ice into the freezer every 24 hours. Look in the Yellow Pages under "Dry Ice", "Dairies", or "Ice Cream Manufacturers" for local dry ice suppliers. Always wear gloves and use caution when handling dry ice.

If the freezer has stopped operating, see the "Freezer does not run" section in the Avoid Service Checklist section of this use and care guide. If you cannot solve the problem, call an authorized service personnel immediately.

If the freezer remains off for several hours, follow the directions above for the use of dry ice during a power failure. If necessary, take the food to a local locker plant until the freezer is ready to operate. Look in the Yellow Pages under "Frozen Food Locker Plants".

AVOID SERVICE CHECKLIST	Before calling for service, review this list. It may save you time and expense. This list includes common occurrences that are not the result of defective workmanship or materials in this appliance.	
PROBLEM	CAUSE	CORRECTION
FREEZER DOES NOT RUN.		
Freezer does not run.	<ul style="list-style-type: none"> * Freezer is plugged into a circuit that has a ground fault interrupt * Temperature control is in the "OFF" position. * Freezer may not be plugged in, or plug may be loose. * House fuse blown or tripped circuit breaker. * Power outage. 	<ul style="list-style-type: none"> * Use another circuit, if you are unsure about the outlet, have it checked by a certified technician. * See Thermostat Setting. * Ensure plug is tightly pushed into outlet. * Check/replace fuse with a 15 amp time delay fuse. Reset circuit breaker. * Check house lights. Call local Electric Company.
Freezer runs too much or too long.	<ul style="list-style-type: none"> * Room or outside weather is hot. * Freezer has recently been disconnected for a period of time. * Large amount of warm or hot food have been stored recently. * Door/lid is opened too frequently or kept open too long. * Freezer door/lid may be slightly open. * Temperature control is set too low. * Freezer gaskets are dirty, worn, cracked or poorly fitted. 	<ul style="list-style-type: none"> * It's normal for the freezer to work harder under these conditions. * It takes 24 hours for the freezer to cool down completely. * Warm food will cause freezer to run more until the desired temperature is reached. * Warm air entering the freezer causes it to run more. Open the door/lid less often. * See "Door/lid Problems". * Turn control knob to a warmer setting. Allow several hours for the temperature to stabilize. * Clean or change gasket. Leaks in the door/lid seal will cause freezer to run longer in order to maintain desired temperature.
Interior freezer temperature is too cold.	<ul style="list-style-type: none"> * Temperature control is set too low. 	<ul style="list-style-type: none"> * Turn control knob to a warmer setting. Allow several hours for the temperature to stabilize.
Interior freezer temperature is too warm.	<ul style="list-style-type: none"> * Temperature control is set too warm. * Door/lid is opened too frequently or kept open too long. * Freezer door/lid may be slightly open. * Large amount of warm or hot food have been stored recently. * Freezer has recently been disconnected for a period of time. 	<ul style="list-style-type: none"> * Turn control knob to a colder setting. Allow several hours for the temperature to stabilize. * Warm air entering the freezer causes it to run more. Open the door/lid less often. * See "Door/lid Problems". * Wait until the freezer has had a chance to reach its selected temperature. * Freezer requires 24 hours to cool down completely.
Freezer external surface temperature is warm.	<ul style="list-style-type: none"> * The external freezer walls can be as much as 30°F warmer than room temperature. 	<ul style="list-style-type: none"> * This is normal while the compressor works to transfer heat from inside the freezer cabinet.
SOUND AND NOISE		
Louder sound levels, whenever freezer is on.	<ul style="list-style-type: none"> * Modern freezers have increased storage capacity and more stable temperatures. They require high efficiency compressors. 	<ul style="list-style-type: none"> * This is normal. When the surrounding noise level is low, you might hear the compressor running while it cools the interior.
Louder sound levels when compressor comes on.	<ul style="list-style-type: none"> * Freezer operates at higher pressures during the start of the ON cycle. 	<ul style="list-style-type: none"> * This is normal. Sound will level off or disappear as freezer continues to run.
Popping or cracking sound when compressor comes on.	<ul style="list-style-type: none"> * Metal parts undergo expansion and contraction, as in hot water pipes. 	<ul style="list-style-type: none"> * This is normal. Sound will level off or disappear as freezer continues to run.

PROBLEM	CAUSE	CORRECTION
SOUND AND NOISE (Cont.)		
Bubbling or gurgling sound.	* Refrigerant (used to cool freezer) is circulating throughout the system.	* This is normal.
Vibrating or rattling noise.	* Freezer is not level. It rocks on the floor when it is moved slightly.	* Level the freezer by putting wood or metal shims under part of the freezer.
	* Floor is uneven or weak.	* Ensure floor can adequately support freezer. Level the freezer by putting wood or metal shims under part of the freezer.
	* Freezer is touching the wall.	* Re-level freezer or move freezer slightly.
WATER / MOISTURE / FROST INSIDE FREEZER		
Moisture forms on inside freezer walls.	* Weather is hot and humid, which increases internal rate of frost build up.	* This is normal.
	* Door/lid is slightly open.	* See "Door/lid Problems".
	* Door/lid is kept open too long or is opened too frequently.	* Open the door/lid less often.
WATER / MOISTURE / FROST OUTSIDE FREEZER		
Moisture forms on outside freezer walls.	* Door/lid is slightly open.	* See "Door/lid Problems".
ODOR IN FREEZER		
Odors in freezer.	* Interior needs to be cleaned.	* Clean interior with sponge, warm water, and baking soda.
	* Foods with strong odors are in the freezer.	* Cover the food tightly.
DOOR/LID PROBLEMS		
Door/lid will not close.	* Freezer is not level. It rocks on the floor when it is moved slightly.	* Level the freezer by putting wood or metal shims under part of the freezer.
	* Floor is uneven or weak.	* Ensure floor can adequately support freezer. Level the freezer by putting wood or metal shims under part of the freezer.
LIGHT BULB IS NOT ON		
Light bulb is not on.	* The fluorescent lamp or light bulb is burned out.	* See "Fluorescent Lamp" or "Interior Light" on Features Section.
	* No electric current is reaching the appliance.	* See "Freezer Does Not Run".
AUTOMATIC ICE MAKER NOT WORKING (IF EQUIPPED)		
Automatic ice maker not working (some models)	* Ensure the Wire Signal Arm is not in the "UP" position.	
	* Ice maker should produce 4 to 5 pounds of ice in a 24 hour period.	
	* Water supply is turned off.	
	* Water pressure is too low.	
	* The freezer is not cold enough.	

Compact Appliance Warranty Information

Your appliance is covered by a one year limited warranty. For one year from your original date of purchase, Electrolux will pay all costs for repairing or replacing any parts of this appliance that prove to be defective in materials or workmanship when such appliance is installed, used and maintained in accordance with the provided instructions.

Exclusions: This warranty does not cover the following:

1. Products with original serial numbers that have been removed, altered or cannot be readily determined
2. Product that has been transferred from its original owner to another party or removed outside the USA or Canada.
3. Rust on the interior or exterior of the unit.
4. Products purchased "as-is" are not covered by this warranty.
5. Food loss due to any refrigerator or freezer failures.
6. Products used in a commercial setting.
7. Service calls which do not involve malfunction or defects in materials or workmanship, or for appliances not in ordinary household use or used other than in accordance with the provided instructions.
8. Service calls to correct the installation of your appliance or to instruct you how to use your appliance.
9. Expenses for making the appliance accessible for servicing, such as removal of trim, cupboards, shelves, etc., which are not a part of the appliance when it is shipped from the factory.
10. Service calls to repair or replace appliance light bulbs, air filters, water filters, other consumables, or knobs, handles, or other cosmetic parts.
11. Surcharges including, but not limited to, any after hour, weekend, or holiday service calls, tolls, ferry trip charges, or mileage expense for service calls to remote areas, including the state of Alaska.
12. Damages to the finish of appliance or home incurred during installation, including but not limited to floors, cabinets, walls, etc.
13. Damages caused by: services performed by unauthorized service companies; use of parts other than genuine Electrolux parts or parts obtained from persons other than authorized service companies; or external causes such as abuse, misuse, inadequate power supply, accidents, fires, or acts of God.
14. Labor costs after ninety (90) days from your original date of purchase incurred for product wear or replacement as provided herein for carry-in appliances.

DISCLAIMER OF IMPLIED WARRANTIES: LIMITATION OF REMEDIES

CUSTOMER'S SOLE AND EXCLUSIVE REMEDY UNDER THIS LIMITED WARRANTY SHALL BE PRODUCT REPAIR OR REPLACEMENT AS PROVIDED HEREIN. CLAIMS BASED ON IMPLIED WARRANTIES, INCLUDING WARRANTIES OF MERCHANTABILITY OR FITNESS FOR A PARTICULAR PURPOSE, ARE LIMITED TO ONE YEAR OR THE SHORTEST PERIOD ALLOWED BY LAW, BUT NOT LESS THAN ONE YEAR. ELECTROLUX SHALL NOT BE LIABLE FOR CONSEQUENTIAL OR INCIDENTAL DAMAGES SUCH AS PROPERTY DAMAGE AND INCIDENTAL EXPENSES RESULTING FROM ANY BREACH OF THIS WRITTEN LIMITED WARRANTY OR ANY IMPLIED WARRANTY. SOME STATES AND PROVINCES DO NOT ALLOW THE EXCLUSION OR LIMITATION OF INCIDENTAL OR CONSEQUENTIAL DAMAGES, OR LIMITATIONS ON THE DURATION OF IMPLIED WARRANTIES, SO THESE LIMITATIONS OR EXCLUSIONS MAY NOT APPLY TO YOU. THIS WRITTEN WARRANTY GIVES YOU SPECIFIC LEGAL RIGHTS. YOU MAY ALSO HAVE OTHER RIGHTS THAT VARY FROM STATE TO STATE.

If You Need Service: Keep your receipt, delivery slip, or some other appropriate payment record to establish the warranty period should service be required. If service is performed, it is in your best interest to obtain and keep all receipts. Service under this warranty must be obtained by contacting Electrolux at the addresses or phone numbers below.

This warranty only applies in the USA and Canada. In the USA, your appliance is warranted by Electrolux Major Appliances North America, a division of Electrolux Home Products, Inc. In Canada, your appliance is warranted by Electrolux Canada Corp. Electrolux authorizes no person to change or add to any obligations under this warranty. Obligations for service and parts under this warranty must be performed by Electrolux or an authorized service company. Product features or specifications as described or illustrated are subject to change without notice.

USA
1.800.944.9044
Electrolux Major Appliances
North America
P.O. Box 212378
Augusta, GA 30907

 **Electrolux**

Canada
1.800.868.4606
Electrolux Canada Corp.
5855 Terry Fox Way
Mississauga, Ontario, Canada
L5V 3E4

SECTION B - ELECTRONIC CONTROLS GUIDE

TEMPERATURE CONTROL

TEMPERATURE SETTING

The desired temperature inside the freezer can be set using the UP (%) and DOWN (%) buttons on the control panel, located on the door/lid of the freezer. Press either the UP or DOWN buttons once to display the current setting. You may now use the UP and DOWN buttons to change the temperature setting to one which suits your needs. The range of settings is -10°F to 10°F (-24°C to -12°C) (see figures 1 and 2). The display will return to showing the temperature of the cabinet after five (5) seconds of inactivity.

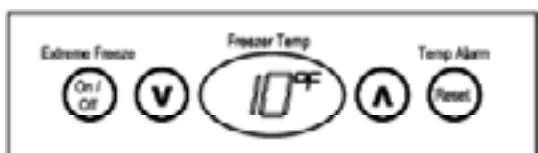

Figure 1

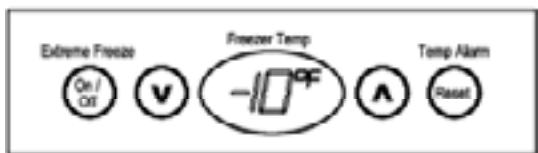

Figure 2

You may also turn off the freezer by pressing the UP button when at temperature setting of 10°F (-12°C). The display will read OFF (see figure 3). The freezer will not cool anything while it is in OFF position. The door light will continue to operate while in OFF .

WARNING: The freezer still has electrical power while in OFF. Disconnect freezer from the outlet before cleaning or moving it.



Figure 3

TEMPERATURE MODE CHANGE

Temperature display can be changed from °F to °C to °F by pressing the ALARM RESET and DOWN arrow simultaneously until the control panel beeps. The display will change to the other mode.

EXTREME FREEZE

Extreme Freeze enables the compressor to run continuously to help cool large quantities of warm (room temperature) foods faster. Always cool down hot foods to room temperature before placing them in the freezer. Use this feature just prior to adding large quantities of unfrozen foods (not to exceed three (3) pounds per cubic foot of freezer space). For example, do not place more than 45 pounds of room temperature food into a 15 cubic foot freezer.

To activate the Extreme Freeze feature, push the Extreme Freeze button. The control panel will beep once and the display will now read "FF" indicating that Extreme Freeze has begun (see figure 4).



Figure 4

For your convenience, Extreme Freeze will automatically turn off after a period of 72 hours and the freezer will return to the previous temperature setting. You may deactivate Extreme Freeze at anytime by pressing the Extreme Freeze button. The display will return to showing the current temperature inside the freezer and the control panel will beep once.

DISPLAY LOCKOUT

Press and hold the ALARM RESET key until the control panel beeps to activate or deactivate the Display Lockout feature which prevents the user from accidentally changing the temperature and extreme freeze settings. "LOC" (LOCK) will be displayed for three (3) seconds indicating that the control panel is locked (see figure 5). Once in lockout when a key is pressed, "LOC" will display for three (3) seconds. When the lockout is deactivated, "UL" (UNLOCK) will display for 1 second (see figure 6).

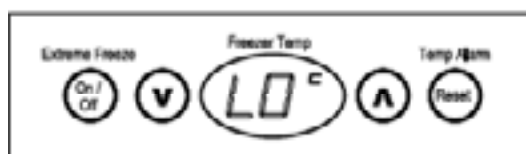

Figure 5



Figure 6

ALARM FUNCTIONS

TEMPERATURE ALARM

If the cabinet temperature rises to a level above 23°F (-5°C), a high temperature alarm will be activated. The control panel will beep every five (5) seconds, the red alarm light will glow and the display will flash. This will continue until the problem is determined, corrected and temperature once again drops to a level below 23°F (-5°C). You may stop the beep by pressing the ALARM RESET button. To also stop the display from flashing, press and hold the ALARM RESET button until the control panel beeps. Temperature Alarm will reactivate itself upon reaching a safe temperature.

DOOR / LID AJAR ALARM

The door/lid alarm will activate if it is ajar for more than five (5) minutes. The control panel will beep every five (5) seconds, the red alarm light will glow and the display will alternate between “d” (DOOR/LID) and the cabinet temperature (see figure 7). Press the ALARM RESET button to turn the audible alarm (beep) off. The display will keep flashing and the red light will stay on. Close the door/lid of the freezer to return it to normal operation.

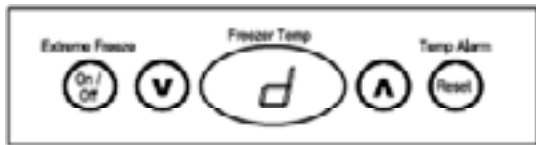

Figure 7

POWER FAILURE (Models with 9 Volt Battery)

If power to the freezer is lost, the power loss alarm will activate. The display will be off but the control panel will beep every minute (see figure 8). To turn the audible alarm (beep) off, press the ALARM RESET button. The audible alarm will also turn off automatically when power is reconnected to the freezer. The temperature alarm will activate if the temperature of the cabinet rises to a level above 23°F (-5°C) during power failure. The red alarm light however, will not illuminate.



Figure 8

SYSTEM ERROR ALARM

The display will alternate between temperature and “CE” or “E” and the control panel will beep every five (5) seconds (see figures 9 and 10). Press the ALARM RESET button to turn the audible alarm (beep) off. Call service repair to correct the problem.



Figure 9



Figure 10

ALARM FUNCTION TABLE

Except during power loss, the red alarm light illuminates whenever there is an alarm status.

Display Status	Function	Response
Cabinet temperature is displayed	Normal Operation	None
FF is displayed	Extreme Freeze	None
Temperature flashing on and off. Control panel beeps every 5 seconds.	Freezer temperature too high	Check power is connected. Contact service technician. Press ALARM RESET to shut off audible alarm (beep)
Alternating 'd' and temperature. Control panel beeps every 5 seconds.	Door ajar	Close door. Press ALARM RESET to stop audible alarm (beep)
Alternating 'E' and temperature. Control panel beeps every 5 seconds.	Operational error	Contact service technician. Press ALARM RESET to stop audible alarm (beep).
Alternating 'CE' and temperature. Control panel beeps every 5 seconds.	Operational error	Contact service technician. Press ALARM RESET to stop audible alarm (beep).
Display off.	Power failure	Reconnect power connection.

Display Lock/Unlock: Press and hold ALARM RESET until the control panel beeps to lock or unlock the display.

SECTION C - ELECTRICAL OPERATION

Electrical mechanical control models:

Electrical mechanical control models have three basic circuits:

1. The electrical circuitry that controls and powers the compressor.
2. The electrical circuitry for the alarm function, and power on indicator light.
3. The electrical circuitry for the freezer light.

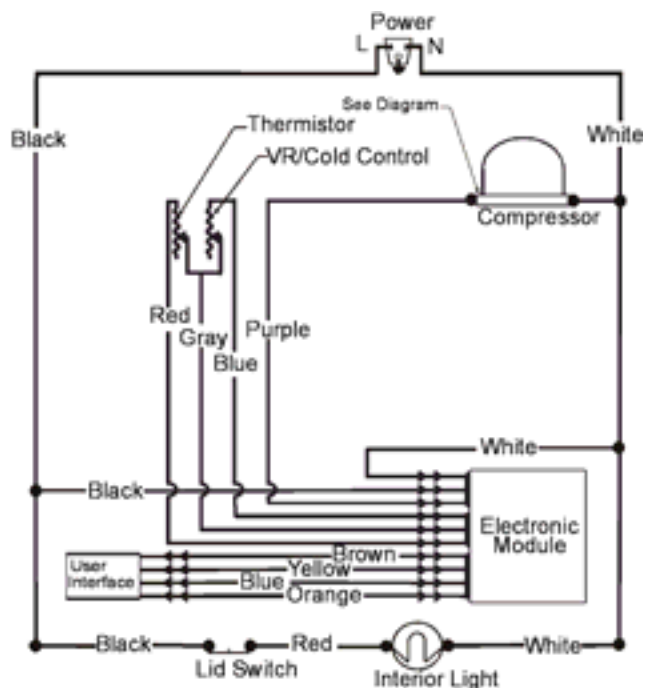

Compressor circuit

When power is applied to the freezer. Line is connected to the electronic module and the lid switch. Neutral is connected to one side of the compressor, interior light, and the electronic module. With line and neutral both applied to the electronic module, the module activates and checks the resistance of the cold control. The resistance of the cold control tells electronic module, if the control is turned off or at what temperature the freezer should operate. The temperature in the freezer is sensed by a thermistor, which is a device that changes resistance as the temperature changes. If the cold control is set at any position other than off, the electronic module reads the resistance of the thermistor, and calculates the temperature in the freezer compartment. If the tem-

perature in the freezer is above the upper limits of the control setting, the electronic module applies line voltage to the compressor circuit, starting the compressor. With the compressor operating the sealed system cools the freezer compartment. As the freezer compartment cools the resistance of the thermistor increases. The electronic module monitors the resistance of the thermistor as it increases. When the temperature in the freezer reaches the lower limits of the control setting the resistance of the thermistor tells electronic module to remove power from the compressor.

Alarm function circuit

The components that make up the alarm function and power on light circuits are the user interface and electronic module. The alarm function is designed to alert the user if the temperature in the freezer goes above 23°F for any reason. The power on light gives the user a visual indication that power is applied to the freezer. Note both the power on light and the alarm function operate with the cold control set to off or at a temperature setting.

The user interface is made up of the alarm off switch and two indicator lights. A yellow light to indicate that power is being applied to the freezer and a red light for the temperature alert.

When power is applied to the freezer, the electronic module applies power to the yellow indicator light causing it to glow.

The electronic module constantly monitors the temperature in the freezer compartment. If the temperature in the freezer compartment goes above 23°F, the electronic module will beep every five seconds and the red alarm light will flash. The beeping will continue until either the freezer goes below 23°F or the alarm off switch is pushed. The red indicator light will continue to flash until the temperature in the freezer goes below 23°F.

Freezer light circuit

The freezer light circuit is made up of the lid switch and the freezer interior light. When the freezer lid is open to contacts of the lid switch close and apply power to the freezer interior light.

Standard electronic control models:

The models with the standard electronic control have five basic electrical circuits:

1. The sealed system circuit made up of the electronic control, compressor and evaporator fan motor.
2. The defrost circuit is made up of the electronic control, defrost thermostat and the defrost heater.
3. The interior light circuit is made up of the door switch and the interior light.
4. The power on light circuit is made up of the power on light.
5. The alarm circuit is made up of the alarm sensor, temperature warning light, alarm off/on switch and the buzzer.

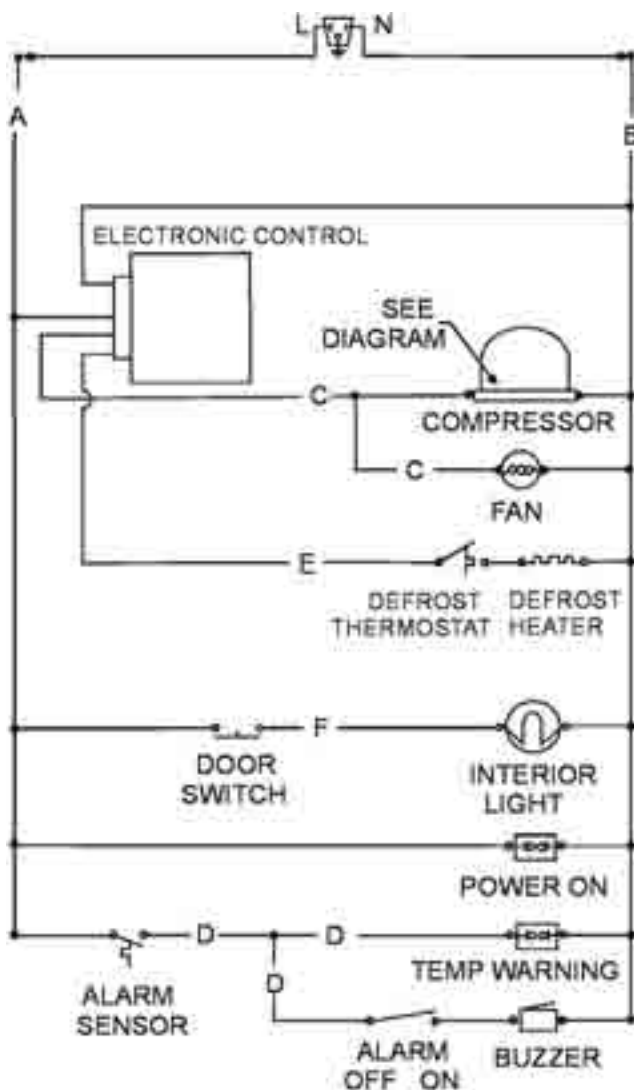

Sealed system circuit

When the freezer is plug-in, powers apply to electronic control. The electronic control has a keypad with up and down arrows that allows the user to turn the control off, or select the freezers operating temperature. The preset temperature settings are shown in the control's display as numbers from zero to seven, with zero being off and seven being the coldest.

A thermistor in the control is used to sense the temperature of the freezer. If the electronic control is program for any number, other than zero, the control reads the resistance of the thermistor and compares it to the pre-programmed temperature setting. If the resistance indicates that the temperature in the freezer is above the upper limits of the preprogramed temperature setting, the control applies power to the compressor and the evaporator fan motor. This cools the freezer compartment and causes the resistance of the thermistor to increase. When the temperature in the freezer compartment reaches the lower limits of the control setting, the control removes power from the compressor and evaporator fan motor. By cycling the compressor and evaporator fan motor off and on electronic control maintains the preset temperature in the freezer compartment.

Defrost circuit

The electronic control has a preprogram defrost program that performs a 30 minute defrost cycle after every 12 hours of compressor run time. After 12 hours of compressor run time, the defrost section of the electronic control activates providing line to neutral voltage across the defrost thermostat and the defrost heater for 30 minutes. The defrost thermostat is a safety device that is used to prevent damage to the cabinet by the defrost heater. Although the control provides line to neutral voltage for 30 minutes, during a normal defrost cycle, the contacts of the defrost thermostat open at about the 12 to 14 minute mark removing power from the defrost heater. The remaining time of the defrost cycle allows the water to drip off the evaporator, so it does not re-freeze when the compressor starts at the end of the defrost cycle.

Interior light circuit

Whenever powers is applied to the freezer, line to neutral voltage is applied across the door switch and interior light circuit. When the freezer doors is close the contacts of the door switch are open preventing current from flowing in the circuit. When the door is opened the contacts of the door switch close allowing current to flow through the circuit causing the interior light to glow.

Power on indicator light circuit

The power on indicator light is connected between line and neutral. Whenever power is applied to the freezer the indicator light glows, giving a visual indication that power is applied to the freezer.

Alarm circuit

The alarm circuit is a series parallel circuit, with line voltage being applied to the alarm sensor. If the temperature in the freezer goes above 23°F. the contacts of alarm sensor close. This applying power to the parallel circuit formed by the temperature warning light circuit and the alarm off/on switch and the buzzer circuit. The buzzer may be deactivated by placing the alarm off on switch to the off position.

Deluxe electronic control models:

The models with the deluxe electronic control have five basic electrical circuits:

1. Electronic module and user interface circuit that is made up of the user interface, electronic module and thermistor.
2. Sealed system circuit that is made up of electronic module, the evaporator fan motor and the compressor.
3. Defrost circuit that is made up of electronic module, defrost heater, and defrost thermostat.
4. Interior light circuit that is made up of the electronic module, door switch and the interior light.

Note: The 9 V battery backup is not available on some models and the icemaker comes as a kit.

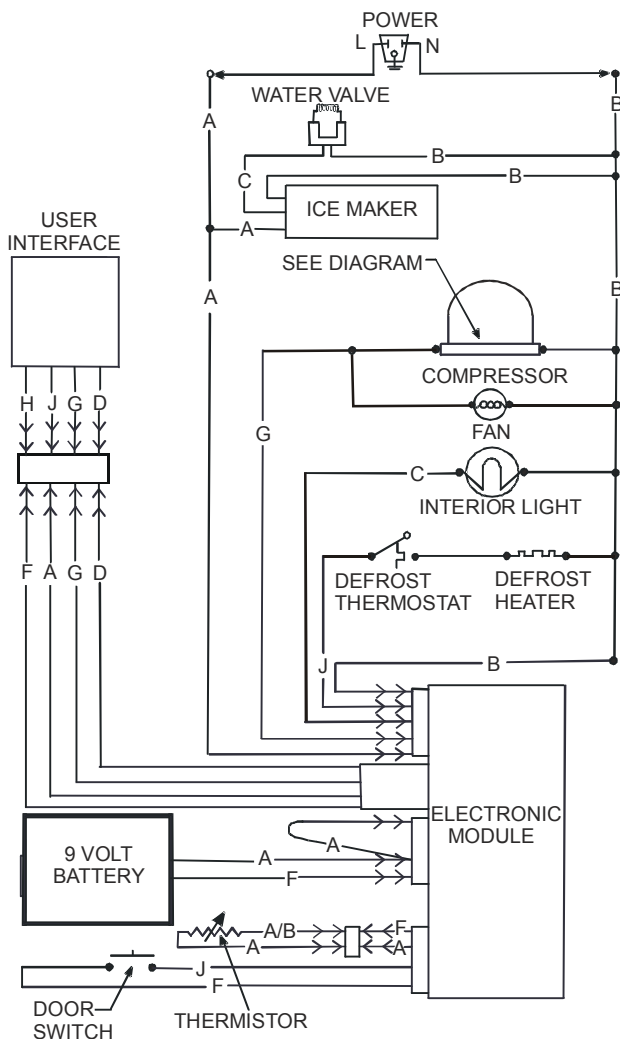

Electronics module and user interface circuit

The electronic module controls the operation of the freezer with inputs from the arrows on the interface, the extreme freeze switch, the alarm off switch, the thermistor, and door switch. The outputs of the electronic module are to the display of the interface, the compressor and evaporator fan circuit, the defrost circuit and the temp alarm indicator light.

The electronic module uses the input from the up and down arrows to raise or lower the temperature at which the freezer operates or to turn the control off. The input from the extreme freeze switch tells the control to apply power to the compressor evaporator fan circuit for 72 hours or until the switch is pushed again. During an extreme freeze operation, the 30 minute defrost occurs every 12 hours of compressor run time. Pushing the alarm off switch tells the electronic module to turn the beeper off when the alarm function is operating. The input from the thermistor allows electronic module to calculate the temperature in the freezer compartment. With this knowledge the module cycles the compressor and evaporator fan circuit off and on to maintain the temperature at the program level. The module also uses this information to activate the alarm circuit, when the input from the thermistor indicates the temperature in the freezer compartment is about 23°F. When the door is opened the closing of the contacts the door switch tells the timer function of the module to start a five minute countdown. If the contacts of the door switch do not open within the five minute the module activates the door ajar alarm.

Sealed system circuit

The electronic module, evaporator fan motor, and compressor form a series circuit. When the electronic module determines that the temperature in the freezer is above its preset limits, the relay on the module closes and provides line to neutral voltage to the evaporator fan motor and the compressor. With the evaporator fan motor and compressor running the freezer compartment cools down. When the temperature in the freezer compartment reaches the preset lower limit in the module the relay opens removing power from the evaporator fan motor and the compressor.

Defrost circuit

The timer section of the electronic module, records the compressor run time. When the accumulated run time of the compressor reaches 12 hour, the module turns off the compressor and activates defrost circuit. For 30 minutes the module supplies lined a neutral voltage to the series circuit formed by the defrost heater and the defrost thermostat. The defrost thermostat is a safety device connected in the circuit to protect the freezer liner, if the defrost heater is allowed to remain on too long. In a normal defrost cycle the contacts of the defrost thermostat opens at about the 12 to 14 minute mark stopping current flow in the circuit. During the rest of the 30 minutes the water is allowed to drain off the evaporator, so it does not refreeze when the compressor restarts.

Interior light circuit

The interior light circuit is a series circuit formed by the electronic module, the door switch and the interior light. The electronic module provides line to neutral voltage to the interior light circuit, whenever powers applied to the freezer. When the freezer door is closed, the contacts of the of the door switch are open, preventing current flow in the circuit. When the door is open, the contacts of the switch are closed and current flows through the circuit causing the light to glow. When current flows in the circuit the timing section of electronic module is activated for a five minute countdown. If the current flow in the interior light circuit is interrupted, by closing the door, which in turn opens the contacts of the door switch, the countdown is stopped. If the door is not closed within the five minute, the door alarm function is activated, notifying the user to close the door.

SECTION D - REFRIGERATION SYSTEM & SERVICE

NOTICE: Instructions given here are furnished as a guide. Persons attempting to use these to make repairs to the sealed refrigeration system should have a working knowledge of refrigeration and previous training on sealed system repair.

Safety

WARNING **Compressor Testing:** Whenever testing a compressor, extreme caution should be used to prevent damaging the terminals. A compressor with a damaged terminal or a grounded terminal winding can expel a terminal from its insulated housing when the compressor is energized. If this happens, a mixture of refrigerant and oil will be released that could be ignited by an external heat source (open flame, heater, etc.). Also, if there is air in the system when it happens, a spark at the compressor shell could ignite the refrigerant and oil mixture.

WARNING **Charging Sealed Systems:** Over charging a freezer system with refrigerant can be dangerous. If the overcharge is sufficient to immerse the major parts of the motor and compressor in liquid refrigerant, a situation has been created which, when followed by a sequence of circumstances, can lead to the compressor shell seam separating.

A hydraulic block occurs preventing the compressor from starting. This condition is known as locked rotor. Electrical current continues to flow through the compressor motor windings which become, in effect, electrical resistance heaters. The heat produced begins to vaporize the excess refrigerant liquid, causing a rapid increase in system pressure. If the compressor protective devices fail, the pressure within the system may rise to extremes far in excess of the design limits. Under these conditions, the weld seam around the compressor

shell can separate with explosive force, spewing oil and refrigerant vapor which could ignite.

To eliminate this exceedingly rare but potential hazard, never add refrigerant to a sealed system. If refrigerant is required, evacuate the existing charge and recharge with the correct measured amount of refrigerant specified for the system.

Soldering

CAUTION Wear the proper and approved safety glasses when working with or on any pressurized system or equipment. Have an approved dry type fire extinguisher handy when using any type of gas operated torch.

1. All joints to be soldered must have a proper fit. The clearance between tubes to be soldered should be from .001" to .006". It is not practical to actually measure this, however you do not want a dry fit or a loose fit. The tubing joints should overlap about the distance of their diameter except for restrictor tubes which should be inserted 1.25"
2. Clean all joint areas with fine steel wool or preferably an abrasive cloth, such as grit cloth No. 23 or "Scotch-Brite."
3. Apply a thin film of a liquid flux recommended for silver soldering to the surfaces to be joined, and to the surfaces immediately adjacent to the joint.
4. Align the tubing so that there is no stress on the joint. Do not move the tubing while the solder is solidifying or leaks will result.

CAUTION During the application of heat, use wet cloths to prevent the heat from conducting to areas other than the soldered joint. Use a sheet of metal as a heat deflector to keep the flame away from inflammable materials and painted surfaces.

5. Use a torch of adequate capacity so that the joint can be quickly heated with a minimum of heat travel to other points. Use a good grade of silver solder.
6. Solder the connections. If the tubing is properly cleaned and fluxed, solder will flow readily. Do not use an excessive amount of solder, just enough to make a good bond.

7. Allow the joint to cool then wash exterior with water to remove flux.

Refrigeration System

Basic components of a refrigeration system are:

1. The compressor located in the machine compartment.

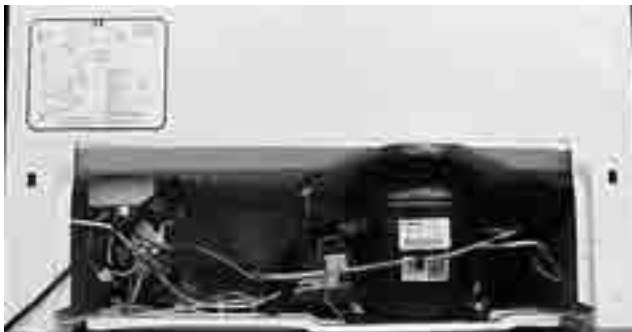

2. The condenser that is foamed to the outer walls of the cabinet.



3. The evaporator mounted to the rear wall of the food compartment or



attached to the food compartment liner.



4. The capillary tube connects the output end of the drier to the input of the evaporator.



5. The filter-drier located in the machine compartment.

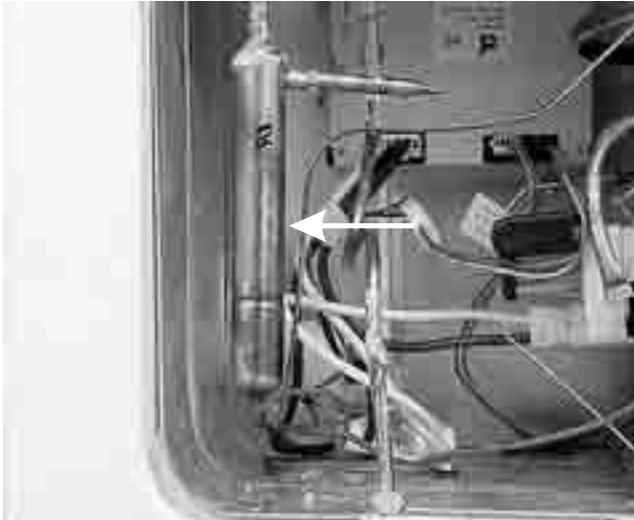

6. The suction line connects the output of the evaporator to the input side of the compressor.



Note: Portions of the capillary tube and the suction line are soldered together to form the heat exchanger.

Refrigerant Cycle

The refrigerant cycle is a continuous cycle that occurs whenever the compressor is in operation. Liquid refrigerant is evaporated in the evaporator by the heat that enters the cabinet through the insulated walls and the heat introduced by the product load and door openings. The refrigerant vapor is then drawn from the evaporator, through the suction line, to the compressor. The pressure and temperature of the vapor is raised in the compressor by compression, and the vapor is then forced through the discharge valve into the discharge line and into the condenser. Air passing over the condenser surface removes heat from the high pressure vapor, which then condenses to a liquid. The liquid refrigerant flows from the condenser to the evaporator, through the small

diameter liquid line (capillary tube). Before it enters the evaporator, it is sub-cooled in the heat exchanger by the low temperature suction vapor in the suction line.

SYSTEM SCHEMATIC

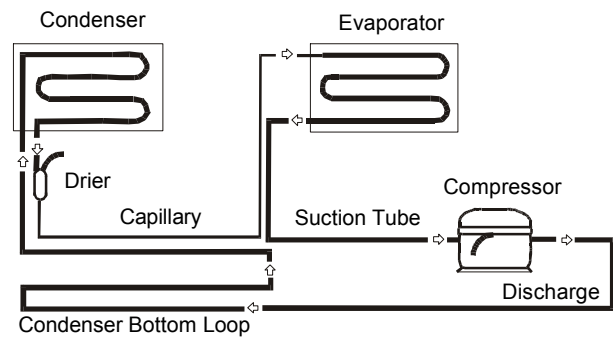

Low or High Side Leak or Undercharge

A loss of refrigerant results in excessive or continuous compressor operation; above normal freezer compartment temperature; a partially frosted evaporator (depending on the amount of refrigerant loss); above normal freezer compartment temperature; low suction pressure (vacuum) and low wattage. The condenser will be “warm to cool,” again, depending on the amount of refrigerant lost.

When refrigerant is added, the frost pattern will improve; the suction and discharge pressures will rise; the condenser will become hot; and the wattage will increase. In the case of a low side refrigerant leak, resulting in a complete loss of refrigerant, the compressor will run, but with no refrigeration. Suction pressure will drop below atmospheric pressure, and air and moisture will be drawn into the system, saturating the filter-drier.

If a slight undercharge of refrigerant is indicated, and no leak could be found after a thorough leak test, the charge can be corrected without changing the compressor.

If there is reason to believe the system has operated for a considerable length of time with no refrigerant, and the leak occurred in the evaporator, excessive amounts of moisture may have entered the system. In such cases the compressor may need to be replaced to prevent repetitive service.

If a high side leak is located and some refrigerant remains in the system, it is not necessary to change the compressor.

Test for Refrigerant Leaks

If the system is diagnosed as short of refrigerant and the system has not been recently opened, there is probably

a leak in the system. Adding refrigerant without first locating and repairing the leak, or replacing the component would not permanently correct the difficulty. THE LEAK MUST BE FOUND. Sufficient refrigerant may have escaped to make it impossible to leak test effectively. In such cases, add a 1/4" line piercing valve to the compressor process tube. Add sufficient refrigerant to increase the pressure to 75 lb. per sq. inch. Through this procedure, slow leaks are more easily detected before discharging the system.

Note: The line piercing valve (clamp on type) should be used for adding refrigerant and test purposes only. It must be removed from the system after it has served its purpose.

Procedure for Checking Condenser Leaks

Before checking for leaks in the condenser, check all accessible system components and joints for leaks.

If a condenser leak is suspected:

1. Discharge the system by using refrigerant recovery equipment.
2. Disconnect the condenser tube from the drier and pinch off and solder both the drier and condenser tube closed.
3. Remove the discharge tube from the compressor and seal the opening to the compressor.
4. Connect a pressure gauge and access valve to the discharge tube and pressurize to 250 lbs. using dry nitrogen or carbon dioxide.

⚠ WARNING Never pressurize with oxygen. Never open a high pressure tank unless it is equipped with a pressure regulator. Never put high pressure on the dome of the compressor. Make sure the gauge and fitting is in good condition and do not leak.

5. Leave the pressure on the condenser for 24 hours. Any drop in pressure is an indication of a leak.

Evacuating and Recharging

CAUTION: Check the serial plate for the correct refrigerant type. It is extremely important to verify the type of refrigerant in the system before starting any sealed system repairs.

CAUTION: With the possible exception of the vacuum pump, all service equipment that comes in contact with R-134a during evacuation and recharging must be dedicated. Accordingly, R-134a will require a dedicated charging cylinder, manifold gauge set, process tube adaptors, and hoses. Any residual mineral oil on other tools (tubing cutter, etc.) must be thoroughly cleaned off before using on R-134a/Ester oil systems. It will be necessary to check with the manufacturer of your vacuum pump for refrigerant and oil compatibility issues.

CAUTION: If you use a vacuum pump with mineral oil to evacuate an R-134a system, it is **ABSOLUTELY ESSENTIAL** to have a shut-off valve between the pump and your manifold gauge set. The hand valve must be closed during all times when the vacuum pump is not operating. This will prevent the migration of mineral oil vapor into the R134a/Ester oil system. If the vacuum pump should stop during evacuation for any reason, the hand pump shut-off valve must be closed immediately.

CAUTION: Insure that your refrigeration hoses are specified for use with R-134a refrigerant. Research has shown that compounds in standard refrigeration hoses may enter sealed systems and ultimately restrict the cap tube in an R-134a system.

Equipment Needed For Evacuation & Recharging:

- Heated charging cylinder.
- Standard 3-port manifold gauge set:
 - 4 charging hoses.
 - Tee fitting with valve core stem removed. (Robinair No. 40396).
 - Hand shut-off valve (Robinair No.40380).
- Two stage vacuum pump.
- Process tube adapter kit (Robinair No. 12458).
- Tubing cutter.
- Pinch-off tool capable of making leak proof seal.

- Complete brazing torch set.
- Small 3-corner file.
- Grit cloth or Scotch-Brite.
- 45% silver solder and flux.

Installing Evacuation and Recharging Equipment:

1. Disconnect the appliance from electrical supply.
2. If compressor was replaced, install correct sized process tube adaptor on process tube. If compressor was not replaced, cut process tube with tubing cutter leaving as much tube as possible and install correct size process tube adaptor.
3. Install correct sized process tube adaptor on high-side process tube.
4. Attach refrigeration service gauge manifold to system in following order:
 - Low-side (compound gauge) hose to suction side process tube adaptor.
 - High-side (pressure gauge) hose to high-side process tube adaptor.
 - Center port manifold hose before hand shut-off valve to charging cylinder.
 - Center port manifold hose after hand shut-off valve to vacuum pump.

Evacuating System

WARNING: R-134A SYSTEMS ARE PARTICULARLY SUSCEPTIBLE TO MOISTURE CONTAMINATION WHICH CAN ONLY BE PREVENTED BY EVACUATING THE SYSTEM FOR A MINIMUM OF 30 MINUTES TO ATTAIN A MINIMUM 29.9 INCH (500 MICRON OR LOWER) VACUUM.

To achieve the required levels of evacuation, a properly maintained two stage vacuum pump in good condition is required. It is absolutely essential to maintain your vacuum pump according to the manufacturer's instructions including required oil changes at the recommended intervals. Vacuum pump oil should always be changed after evacuating a contaminated system. Vacuum pump performance should be checked periodically with a micron gauge.

1. Make certain that charging cylinder valve, hand shut-off valve, and manifold gauge valves are closed.
2. Start vacuum pump.
3. Open hand shut-off valve and slowly open both manifold valves, turning counterclockwise, for two full rotations.

CAUTION: If high vacuum equipment is used, just crack both manifold valves for a few minutes and then open slowly for the two full turns counterclockwise. This will prevent the compressor oil from foaming and being drawn into the vacuum pump.

4. Operate the vacuum pump for a minimum of 30 minutes to a minimum of 29.9" (500 micron) vacuum.
5. Close hand shut-off valve to vacuum pump. Watch compound gauge for several minutes. If reading rises, there is a leak in the system, go to step 6. If no leak is indicated, stop vacuum pump. System is now ready for charging.
6. If a leak is indicated, stop vacuum pump and introduce a small charge of refrigerant into system by cracking valve on bottom of charging cylinder until system is pressurized to 40 or 50 lbs psig.
7. Leak test low-side. Close compound gauge. Run compressor for a few minutes and leak test high side.

When leak is found, recapture refrigerant using EPA approved recovery system Repair and go back to step 1.

Charging the System

CAUTION: Check the serial plate for the correct refrigerant type. It is extremely important to verify the type of refrigerant in the system before starting any sealed system repairs.

CAUTION: After charging the system with liquid be certain to wait at least 5 minutes before starting the compressor to give the refrigerant a chance to disperse throughout the system. Otherwise the compressor could be damaged by attempting to pump excessive quantities of liquid.

Preparing The Charging Cylinder:

1. Make certain that hand shut-off valve to vacuum pump is closed.
2. Close high-side manifold gauge valve.
3. Set charging cylinder scale to pressure indicated on cylinder pressure gauge.
4. Observe refrigerant level in sight glass. Subtract amount to be charged into system and note shut off point.
5. Open charging cylinder valve slowly and allow proper charge to enter system.
6. As soon as refrigerant in sight glass has gone down to predetermined level, close charging cylinder valve.

WARNING: DISCONNECT THE CHARGING CYLINDER HEATER AT THIS TIME TO PREVENT THE CYLINDER PRESSURE FROM EXCEEDING ITS MAXIMUM LIMITS.

7. Allow system to sit for five minutes.
8. Turn on compressor and allow it to run for a few minutes and monitor system pressures.
9. When satisfied that the unit is operating correctly, clamp the high-side process tube with the pinch-off tool while the unit is still running.
10. Slowly open the high-side manifold gauge valve to allow the compressor to remove any refrigerant trapped in the high-side hose and the process fitting.
11. Close both of the manifold gauge valves. If the high-side gauge reading rises, the pinch-off must be corrected before proceeding.
12. Remove the high-side process tube adaptor and solder the process tube closed.
13. Clamp the low-side process tube with the pinch-off tool while the unit is running. Remove the low-side process tube adaptor and solder the process tube closed.
14. Check the process tubes for refrigerant leaks.

Final Leak Test:

1. With the refrigerator turned OFF, leak test all low-side system components.
2. Turn the unit ON and run until the condenser is warm. Leak test the high-side system components.

SECTION E - TROUBLESHOOTING CHART (ELECTRICAL MECHANICAL CONTROL MODELS)

FAILURE	CHECK	CORRECTION
Compressor does not run.	1. Does the power light glow?	Yes, go to step (2). No, checked for power to the freezer and that the freezer is plugged in.
	2. Is the temperature controls set to off?	Yes, turn the temperature control on. No, go to step (3).
	3. Disconnect the wiring harness from the controller and measure the voltage drop between the two wires in the harness. Did the meter read line to neutral voltage?	Yes, defective compressor controller or compressor No, go to step (4).
	4. Disconnect the wiring harness from the temperature control, set the dial to number (4), and measure the resistance between the blue wire and the center black wire. Is the reading between 3500 and 4500 ohms?	Yes, defective electronic module. No, defective temperature control.
Compressor runs continuously, but freezer is not cold.	1. Connect a low side gauge to the processing tube on the compressor. Is the pressure, in a vacuum or lower than normal?	Yes, system low on refrigerant, check for leak in system. No, defective compressor.
Compressor runs continuously and the freezer is too cold.	1. Disconnect the wiring harness from the temperature control, set the dial to number (4), and measure the resistance between the blue wire and the center black wire. Is the reading between 3500 and 4500 ohms?	Yes, go to step (2). No, defective temperature control.
	2. Disconnect the wiring harness from the electronic module that goes to the thermistor and the temperature control. Measure the resistance between the red wire and the gray wire.	If the meter read shorted or open the thermistor is defective. If the meter reads between 50,000 and 70,000 ohms the electronic module is defective.

Note: Always check wiring between components.

FAILURE	CHECK	CORRECTION
Freezer temperatures does not correspond with temperature control settings.	1. Disconnect the wiring harness from the temperature control, set the dial to number (4), and measure the resistance between the blue wire and the center black wire. Is the reading between 3500 and 4500 ohms?	Yes, replace the thermistor, if problem is not corrected replace the electronic module No, replace the temperature control.
Frost pattern does not cover evaporator.	1. Low on gas or restricted.	Check for leaks or restriction.
Buzzer does not sound when temperature in the freezer compartment goes above 23° F.	1. Disconnect the wiring harness from the electronic module that goes to the thermistor and the temperature control. Measure the resistance between the red wire and the gray wire. Is the resistance between 10,000 and 35,000 ohms?	Yes, defective electronic module. No, defective thermistor.
Buzzer does not turn off when temp alarm button is pushed.	1. Does the contacts of the temp switch closed, when the temp switch is pushed?	Yes, defective wiring or electronic module No, defective temp switch.
Interior light does not illuminate when door/lid is opened.	1. Check the light bulb with an ohm meter. Is the bulb good?	Yes, defective lid switch. No, defective light bulb.

Note: Always check wiring between components.

SECTION F - TROUBLESHOOTING CHART (STANDARD ELECTRONIC CONTROL MODELS)

FAILURE	CHECK	CORRECTION
Compressor and evaporator fan motor does not run.	1. Is a power on indicator light glowing?	Yes, go to step (2). No, checked for power to the freezer and that the freezer is plugged in.
	2. Is a display in electronic control illuminated?	Yes, go to step (4). No, go to step (3).
	3. Measure the input voltage to the electronic control. Is line to neutral voltage being applied?	Yes, defective electronic control. No, defective wiring harness.
	4. Is the electronic controls set to zero?	Yes, set the control from 1 to 7. No, go to step (5).
	5. Disconnect the wiring harness from the compressor controller and measure the voltage drop between the two wires in the harness. Does the meter read line to neutral voltage?	Yes, defective compressor controller or compressor and evaporator fan motor. No, the defective electronic control.
Compressor does not run, but the evaporator fan motor does.	1. Defective compressor or compressor controller.	Checks compressor and compressor controller.
Evaporator fan motor does not run, but the compressor operates.	1. Is there something blocking the fan blade?	Yes, remove restriction.
		No, defective fan motor.
Electronic control display does not illuminate, but the freezer operates.	1. Defective electronic control.	Replace electronic control.
The electronic control does not respond when the upper or down arrows are pushed.	1. Is the control set to zero?	Yes, the down arrow must be pushed (3) times to advance the control from "0" to "1".
		No, electronic control was defective.
Interior light does not glow when door is opened.	1. Check the light bulb with an ohm meter. Is the bulb good?	Yes, defective door switch.
		No, defective light bulb.
Compressor runs continuously, but freezer is not cold.	1. Connect a low side gauge to the processing tube on the compressor. Is the pressure, in a vacuum or lower than normal?	Yes, system low on refrigerant, check for leak in system.
		No, defective compressor.

Note: Always check wiring between components.

FAILURE	CHECK	CORRECTION
Compressor runs continuously and the freezer is too cold.	1. Defective electronic control.	Replaced the electronic control.
Freezer temperatures do not correspond with temperature control settings, but the compressor operation is normal.	1. Defective electronic control.	Replaced the electronic control.
Freezer does not automatically defrost.	1. Program the control for a manual defrost. Does a defrost operate? 2. Disconnect the incoming line to the defrost thermostat, and the wire from the defrost heater to the control. Measure the resistance across the defrost thermostat and the defrost heater. Is the reading about 25 ohms? 3. Disconnected defrost thermostat from the defrost heater and measure the resistance of the defrost heater. Is a reading about 25 ohms?	Yes, replaced electronic module. No, go to step (2). Yes, defective electronic control. No, go to step (3). Yes, defective defrost thermostat. No, defective defrost heater.
Power on indicator light does not glow.	1. Does the freezer operate?	Yes, defective indicator light. No, check that the freezer is plugged in, and that power is applied to the freezer.
Temp alarm does not sound and temp light does not illuminate, when the temperature in the freezer goes about 23°F.	1. Using an ohm meter check the continuity of the alarm sensor at a temperature above 23°F. Does the meter read zero or infinity?	Zero, check the wiring connections, light, alarm switch and buzzer. Infinity, defective alarm sensor.
Temp alarm light illuminates when the freezer temperature goes above 23°F, but buzzer does not sound.	1. Is the temp alarm switch on? 2. Check the alarm switch with an ohm meter. Does a switch check good?	Yes, go to step (2). No, set the alarm switch to on. Yes, defective buzzer. No, defective alarm switch.
Temp alarm buzzer sounds when the freezer temperature goes above 23°F, but alarm light does not illuminate.	1. Defective light.	Replace light.

Note: Always check wiring between components.

SECTION G - TROUBLESHOOTING CHART (DELUXE ELECTRONIC CONTROL MODELS)

FAILURE	CHECK	CORRECTION
User interface display is blank.	1. Is the freezer plugged in?	Yes, go to step (2). No, plug the freezer in.
	2. Removed interface from the door and disconnects the wire harness from the interface. Measure the voltage between the brown and orange wires in the plug. Is in the reading greater than 4.3 VDC?	Yes, go to step (3). No, go to step (4).
	3. Is a voltage greater than 5.7 VDC?	Yes, replaced electronic module. No, replaced the user interface if problem is not corrected, replaced electronic module.
	4. Disconnect the user interface cable from the electronic module. Measure the voltage between the red wire and the black wire in the harness plug that is connected to the electronic module. Is the voltage 0.3 VDC greater than the voltage reading in step 2?	Yes, open wire or connection, recheck all connections and wiring. If defects cannot be located, replaced the door. No, replaced electronic module.
User interface display shows "CE". This indicating a communication error between the user interface and electronic module.	1. Check the connectors in the wiring between the user interface and electronic module. Is there a wiring problem?	Yes, correct wiring problem. No, go to step (2).
	2. Replace the user interface. Does this correct the problem?	Yes, problem has been solved. No, go to step (3).
	3. Replaced electronic module. Does this correct the problem?	Yes, problem has been solved. No, rechecked the wiring, if the problem still exists, replaced the door.
Cabinet temperature is not within limits.	1. Initiate the service mode (refer to page 20) and checked the thermistor. What appears in the display?	If "C" or "O" appears in the display replace the thermistor. If "--" appears in the display replaced electronic module.

Note: Always check wiring between components.

FAILURE	CHECK	CORRECTION
Freezer does not go into the extreme freeze mode when the extreme freeze button is pushed.	1. Check the wiring and the connections between the user interface and electronic module. Is a wiring defective?	Yes, correct wiring problem. No, replaced the interface board, and if problem is not corrected, replaced electronic module.
Alarms system does not operate when the temperature in the freezer goes above 23°F.	1. Does either the buzzer sound or the indicator light illuminate?	Yes, if the indicator light illuminates, but the buzzer does not sound, replace electronic module. If the buzzer sounds, but the light does not illuminate, replace the user interface. If problem is not corrected, replace the electronic module. No, replaced the electronic module.
Freezer interior light does not illuminate when door/lid is open.	1. Program to control for the service mode (refer to page 20) and check the door switch contacts with the door open. Does the display show "C" or "O"?	If the display shows "O" the light bulb or wiring is defective. If the display shows "C" the switch is defective.
Door/lid ajar alarm does not operate.	1. Program to control for the service mode (refer to page 20) and check the door switch contacts with the door open. Does the display show "O"?	Yes, replaced electronic module. No, replaced the door switch.
Compressor and evaporator fan motor do not run.	1. Does the display show, the internal temperature of the freezer? 2. Disconnected the wire harness from the compressor controller and measure voltage drop between the two pins in the harness. Does the meter read line to neutral voltage or zero?	Yes, go to step (2). No, refer to display is blank or to the display shows "CE" depending on what the display shows. If the meter reads line to neutral voltage, the evaporator fan motor is defective and either the controller or the compressor is also defect. If the meter reads the zero, the electronic module was defective.
The compressor runs, but the evaporator fan does not.	1. Is the evaporator fan blade block?	Yes, remove the restriction. No, replaced evaporator fan motor.
The evaporator fan motor runs, but the compressor does not.	1. Check the compressor and the compressor controller.	Replace the defective item.

Note: Always check wiring between components.

FAILURE	CHECK	CORRECTION
Freezer does not automatically defrost.	1. Program the control for a manual defrost. Does a defrost operate?	Yes, replaced electronic module. No, go to step (2).
	2. Disconnect the orange wire from the defrost thermostat and the white wire from the defrost heater. Measure the resistance between the wire on the thermostat in the wire at the end of the heater. Is the reading about 25 ohms?	Yes, defective electronic control. No, go to step (3).
	3. Disconnected defrost thermostat from the defrost heater and measure the resistance of the defrost heater. Is a reading about 25 ohms?	Yes, defective defrost thermostat. No, defective defrost heater.

SECTION H - TEARDOWN (Upright Models)

This section will describe how to remove components from the freezer. Unless stated, reverse the procedure to reinstall the component.

⚠ WARNING Always remove electrical power from the freezer when working in an area where electrical power is present.

Removing the Wire Shelves:

1. Remove the wire shelves by pushing up on the right side of the shelf and slide the shelf to the right to disengage the left side of the shelf from the liner.

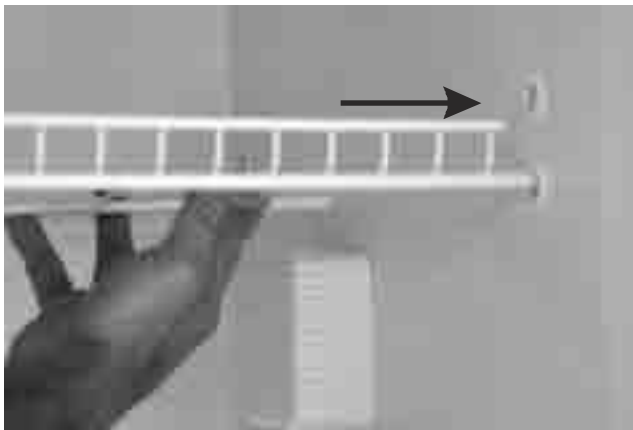

2. Lift up on the left side of the shelf and slide the shelf to the left.

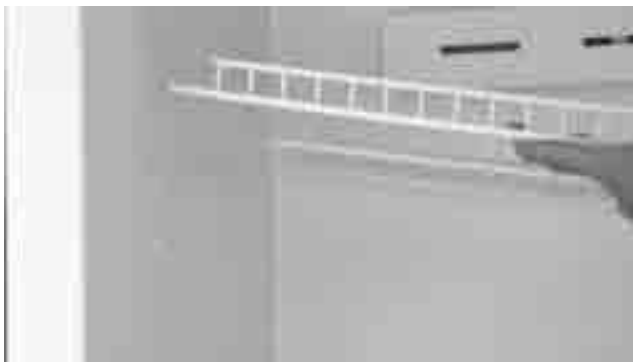

Removing the Glass Shelves:

1. Remove the glass shelves by pushing up on the right side of the shelf and slide the shelf to the right to disengage the left side of the shelf from the liner.

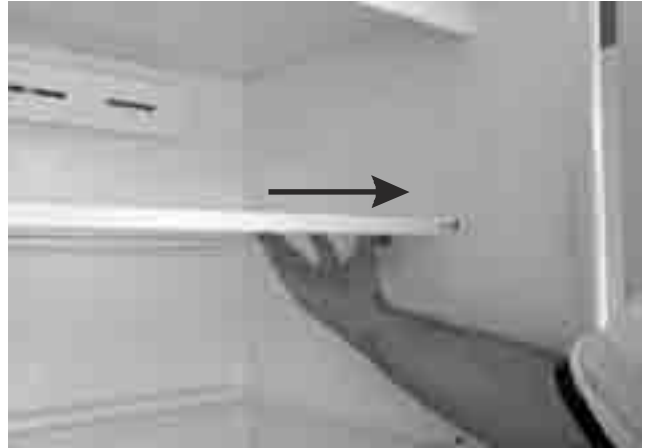

2. Lift up on the left side of the shelf and slide the shelf to the left.



Removing the Lower Wire Basket:

1. Remove the wire basket by pulling the basket out until it hits the stop.

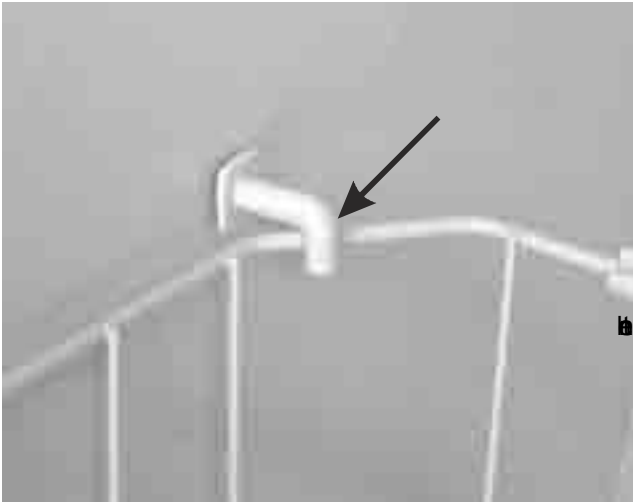

2. Lift up on the front and pull the basket the rest of the way out.



Removing the Upper Wire Basket: (Some Models)

1. Remove the wire basket by pulling the basket out until it hits the stops.



2. Lift up on the front and pull the basket the rest of the way out.



Removing the Upper Wire Basket Side Rails: (Some Models)

1. Remove the upper wire basket.

2. Remove the (3) Phillips screws holding the side rail to the liner.

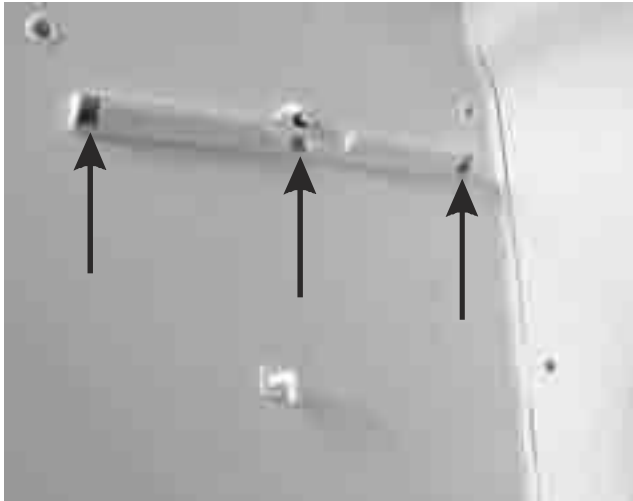

Removing the Door Shelf Guard:

1. Bend the shelf guard out in the middle and pull the tabs out of the door liner.

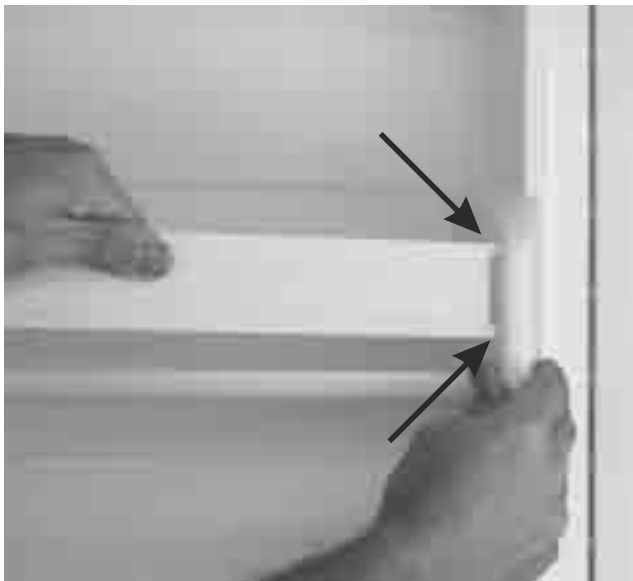

Removing the Door Tilt Out Wire Shelf:

1. Flex the door liner out and lift the wire shelf out of the end cap.



Removing the Door Tilt Out Wire Shelf End Cap:

1. Remove the tilt out wire shelf.
2. Snap the end cap out of the liner.



Removing the User Interface: (Deluxe Control Models)

1. Peel off the overlay.



2. Remove the (2) Phillips screws holding the user interface to the door panel.



3. Lift the user interface out and disconnect the wiring harness.



Removing the Kickplate:

1. Remove the (2) Phillips screws holding the kickplate to the cabinet, and pull the kick plate straight forward.

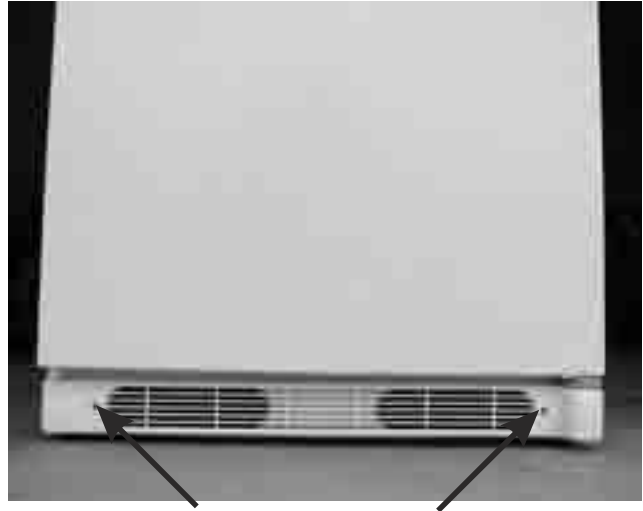

Removing the Door Seal:

Note: The screws that hold the inner door liner to the outer door panel do not go through the door seal.

1. Loosen the screws holding the inner door liner to the outer door panel and slide the door seal out from under the inner door panel.



Removing the Inner Door Liner:

1. Remove the (48) Phillips screws holding the inner door liner to the outer panel, and lift the inner door liner off.

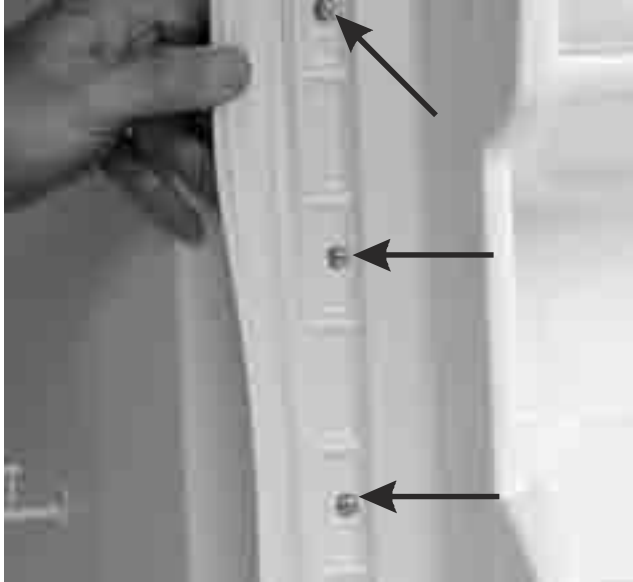

Removing the Door Handle:

Note: The door handle is fastened to the outer liner of the door by a 7/16" nut. The handle is install on the outer door liner before the door is foamed.

1. Remove the inner door liner.
2. Starting at the edge of the metal liner, and using the handle has a positioning guide, using a sharp knife, carefully cut a 1 inch square hole in the foam, behind each end of the handle to reveal the nut.

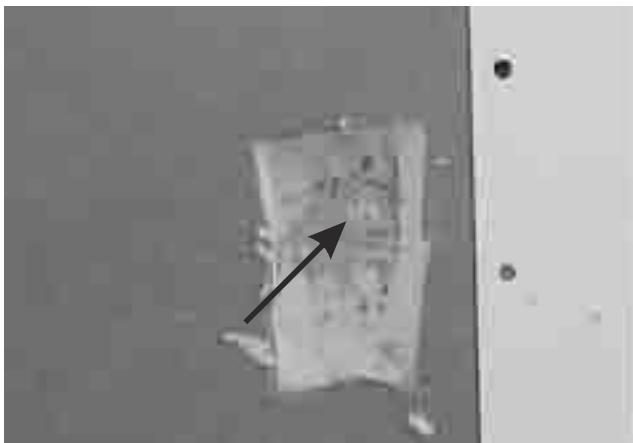

3. Using a deep 7/16 in socket remove the 2 nuts and lift to handle off.

Note: Replace the foam.

Removing the Door Lock Mechanism:

1. Carefully remove enough foam to gain access to the locking fork.
2. Using a common screwdriver push-up on the locking fork until it disengages the lock mechanism.

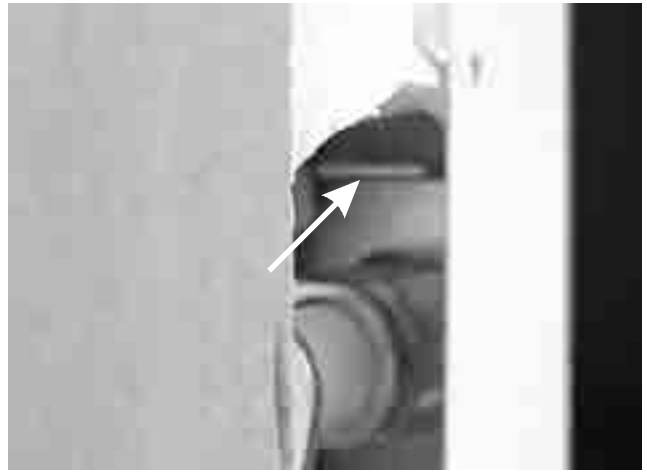

3. Pull the lock assembly out of the door liner.



Note: Replace the foam.

Removing the Upper Door Hinge Cover:

1. The upper door hinge cover snaps to the upper door hinge. To remove the hinged cover insert a common screwdriver between the cover in the door and lift the cover off.



3. Lift the hinge off.



Removing the Upper Door Hinge:

1. Removes the upper door hinge cover.
2. Using a 5/16 in socket remove the (2) screws holding the hinge the Cabinet.

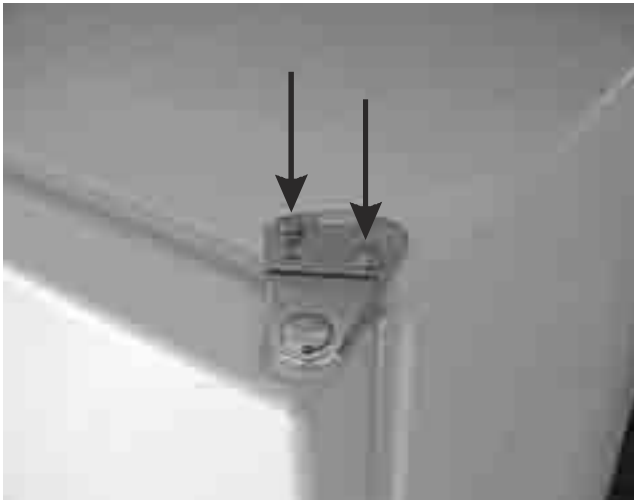

Removing the Door:

1. Remove power from the freezer, and remove the kickplate.
2. On models with the deluxe control system, disconnect the interface wire harness at the electronic module.



3. Pull the wire harness out the front of the freezer.

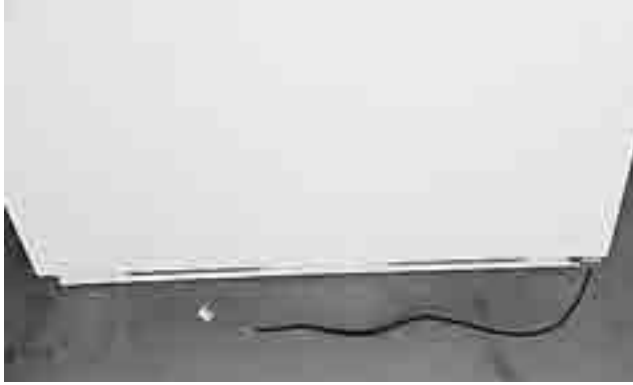

4. Place something under the door to hold it up and using a 5/16 in socket remove the (2) screws holding the lower hinge to the cabinet.

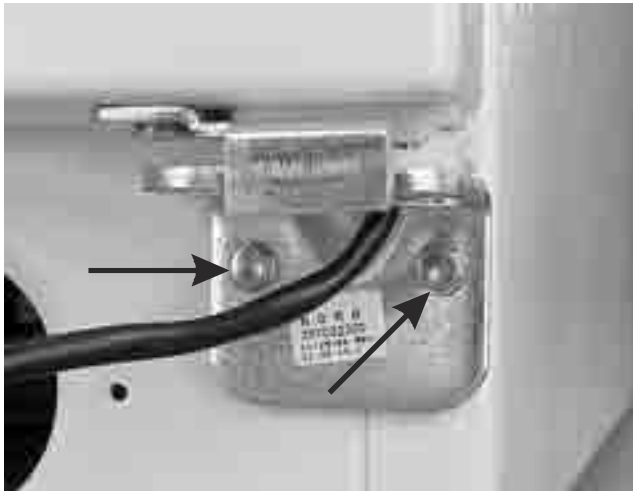

5. Remove the item holding the door up and lower the door off the top door hinge pin to remove the door.

Removing the Bottom Door Hinge and Closer:

1. Remove the door and place it face down on a soft smooth surface.

2. Remove the (2) Phillips screws holding the door closing mechanism to the bottom of the door and lift the hinge and closing mechanism off.



Removing the Air Baffle:

1. The air baffle is held to the rear of the liner by (4) tabs. To remove the baffle roll the top of the baffle forward and lift up to disengage the bottom tabs.

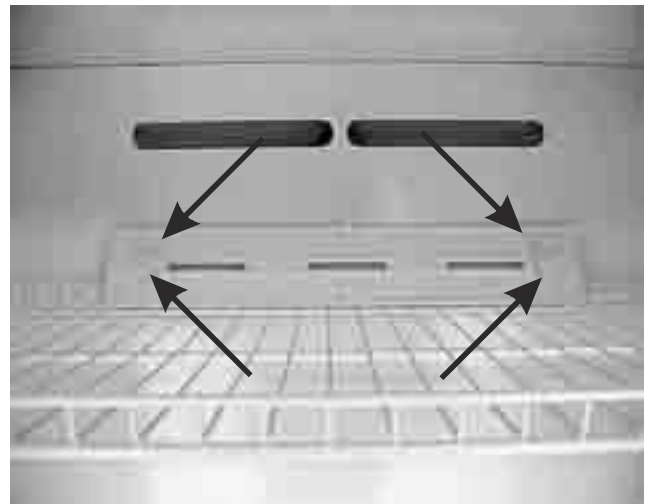

Removing the Alarm Switch, and Indicator Lights Bracket: (Standard Control Models)

1. Remove power from the freezer, and remove the kickplate.

2. Disconnect the (2) wires from the buzzer.



3. Disconnect the wiring harness that goes to the lights and the switch.

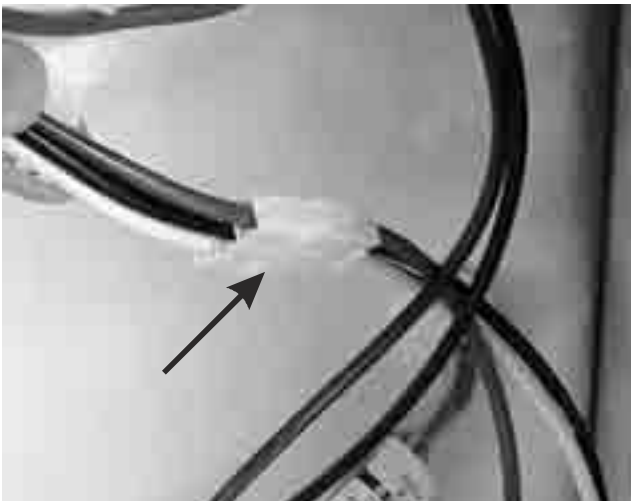

4. Remove the (2) Phillips screws holding the bracket to the cabinet.



Removing either of the Indicator Lights: (Standard Control Models)

1. Remove power from the freezer remove the indicator lights and switch bracket and disconnect the wires from the light that is to be removed.
2. Press in on the tabs on the side of the light and push the light out of the front bracket.

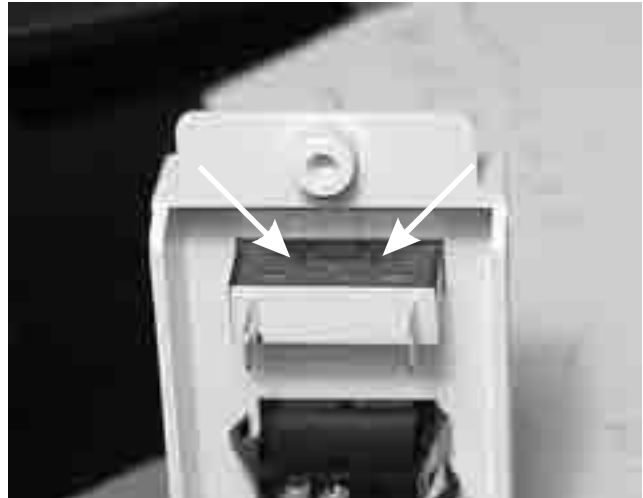

Removing the Alarm Switch: (Standard Control Models)

1. Remove power from the freezer, remove the light and switch bracket and disconnect the wires from the switch.
2. Squeeze the locking tabs on the top and bottom of the switch and pushed the switch out of the front of the bracket.

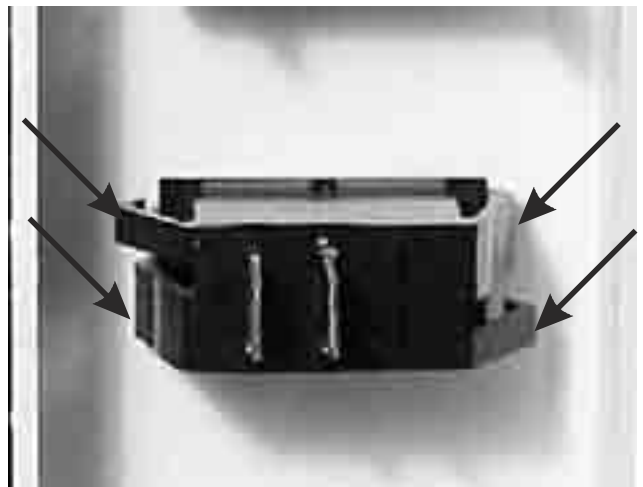

Removing the Lights and Switch Bracket Housing: (Standard Control Models)

1. Remove power from the freezer, and remove the light and switch bracket.
2. Lift up on the locking tab, and pull the housing out the front.



Removing the Alarm Buzzer: (Standard Control Models)

1. Remove power from the freezer, and disconnect the (2) wires from the buzzer.
2. Remove the Phillips head screw holding the buzzer to the top of the machine compartment.

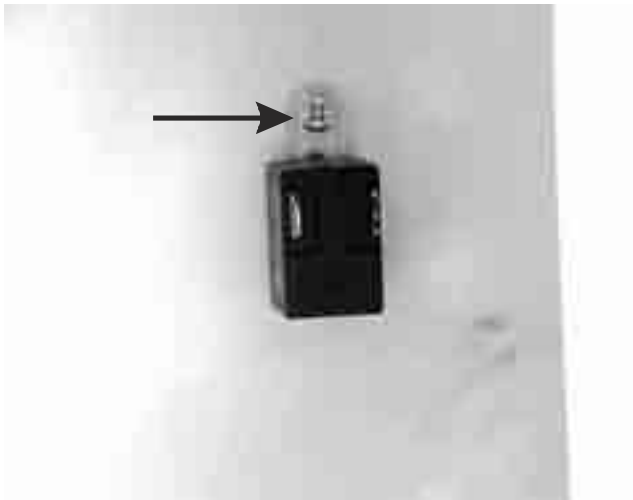

Removing the Light Shield:

1. Remove the (2) Phillips screws holding the shield to the top of the liner and the shield will drop down.

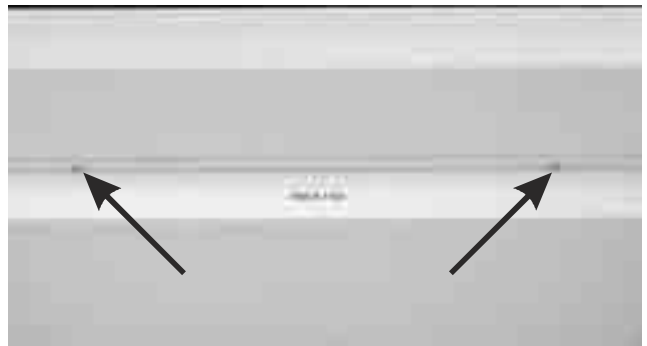

Removing the Light Bulb:

1. Turn the light bulb, counterclockwise to remove.



Removing the Light Bulb Socket:

1. Remove power from the freezer, pull down on the socket and turn the socket one quarter turn.

2. Disconnect the wires.



Removing the Alarm Switch Cover: (Standard Control Models)

1. Squeeze the top and bottom of the cover to disengage the tabs from a liner and lift the cover off.



Removing the Alarm Switch: (Standard Control Models)

1. Remove the alarm switch cover.

2. Unplug the switch from the liner and lift to switch off.

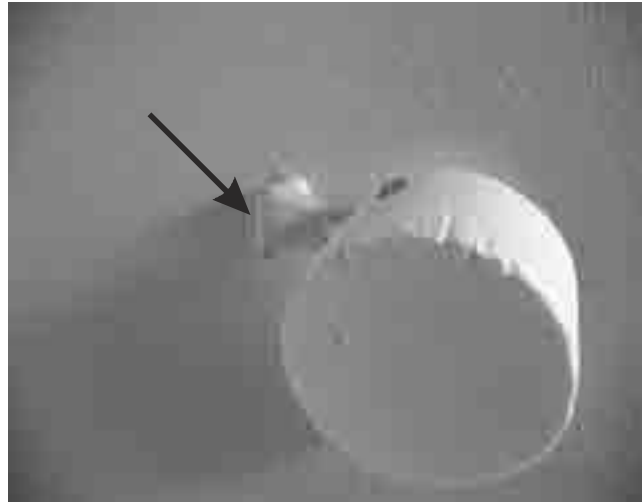

Removing the Evaporator Cover:

1. Remove power from the freezer, remove the wire basket or baskets, on models with two baskets remove one of the upper basket glides and the bottom shelf.
2. Remove the (4) Phillips screws holding the top of the cover to the rear wall liner.

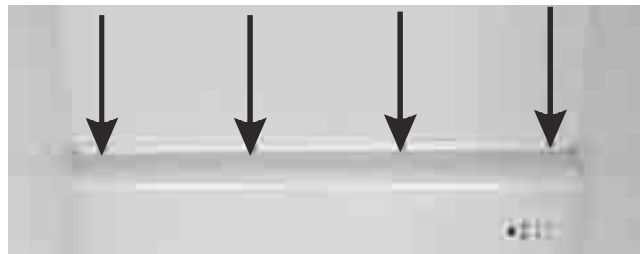

3. Remove the (2) Phillips screws, from the front of the cover, holding the cover to the evaporator standoffs and the (3) Phillips screws holding the cover to the bottom of the liner.

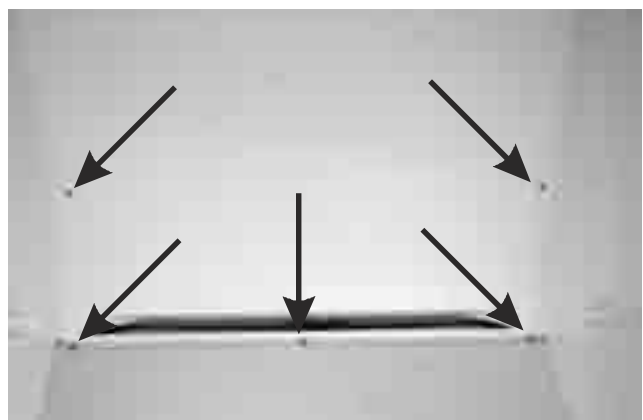

- Slide one side of the cover forward and remove one of the side seal.

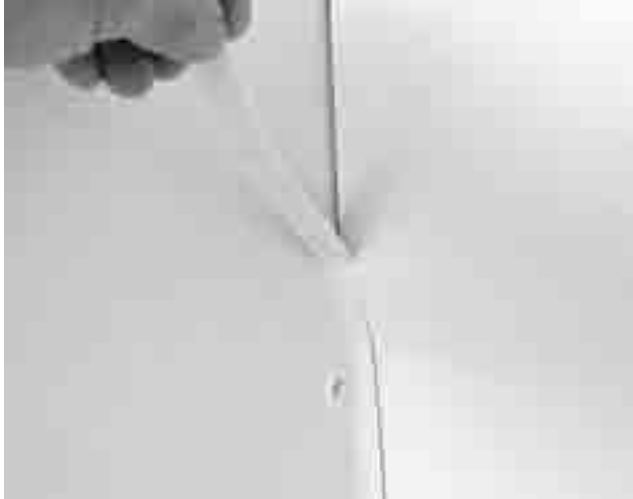

- Remove the electronic control cover by disengaging the four locking tabs holding the cover to the control.

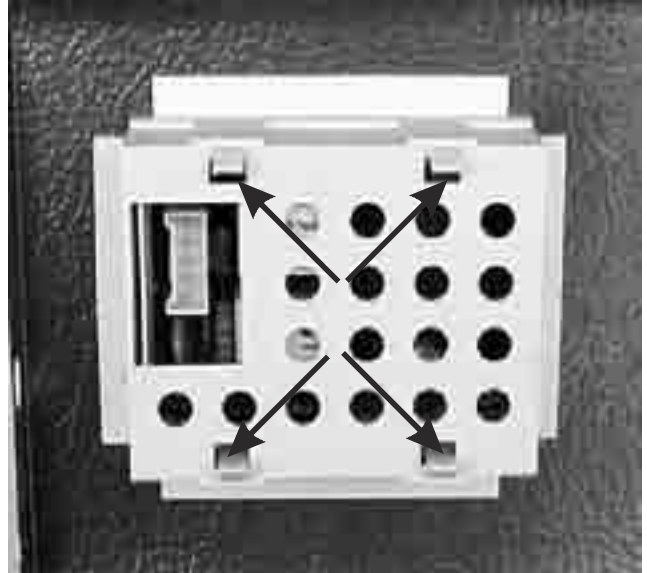

- If the model has a standard control system, unplug the wire harness from the control and lift evaporator cover out.

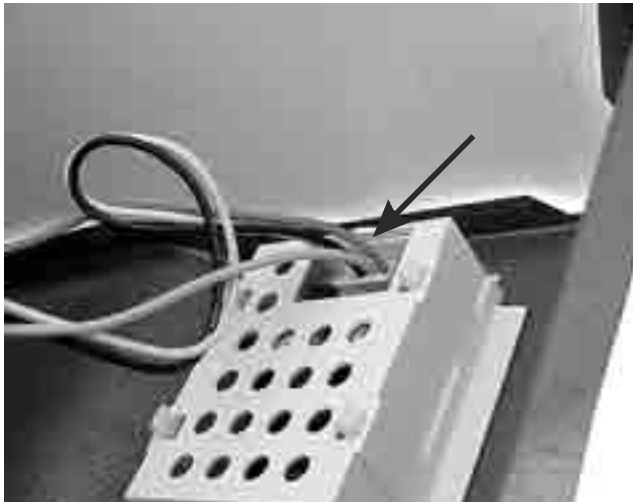

- With the cover removed the control will pull out the front of the evaporator cover.

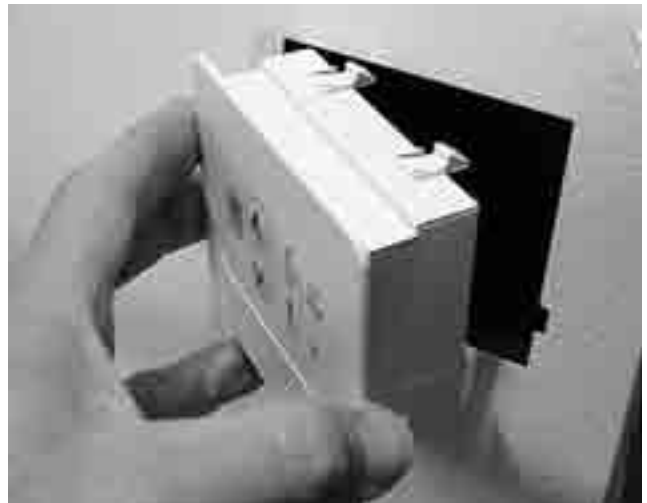

Removing the Electronic Control: (Standard Control Models)

- Remove power from the freezer and remove the evaporator cover.

Removing the Defrost Thermostat:

- Remove power from the freezer and remove the evaporator cover.

2. Disconnect the wires to the thermostat and unplug the thermostat from the evaporator.

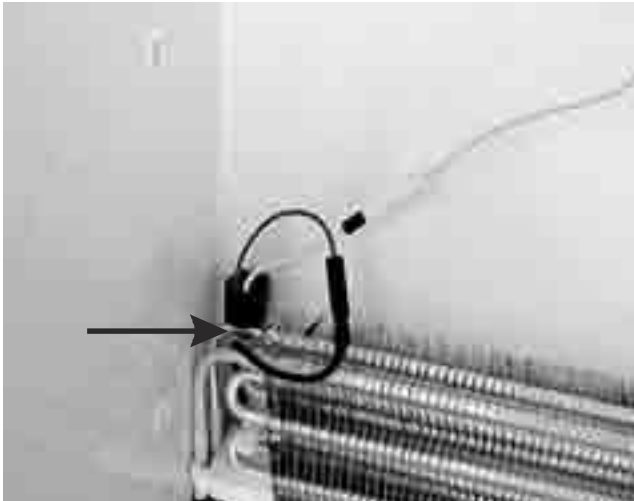

Removing the Defrost Heater:

1. Remove power from the freezer and remove the evaporator cover.
2. Disconnect the wires to the heater.
3. Release the (2) of aluminum straps securing the heater to the bottom of the evaporator.

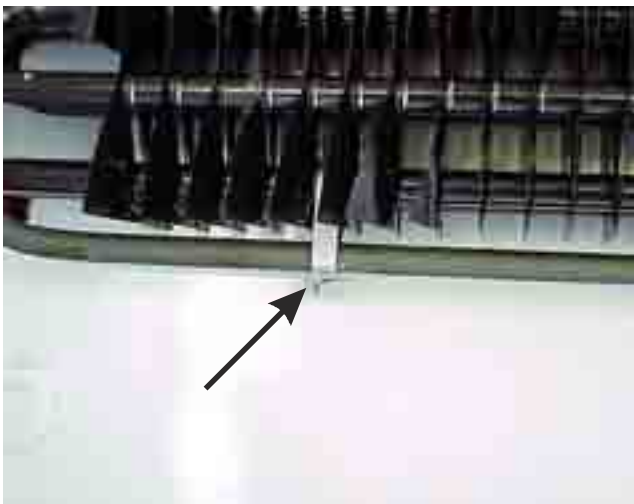

4. Pull the heater down to disengage it from the evaporator.

Removing the Evaporator Fan Assembly:

1. Remove power from the freezer and remove the evaporator cover.

2. Disconnect the wire harness from the evaporator fan motor.

3. Using a 5/16" socket remove the (2) bolts holding the fan bracket to the liner and lift the fan assembly out.

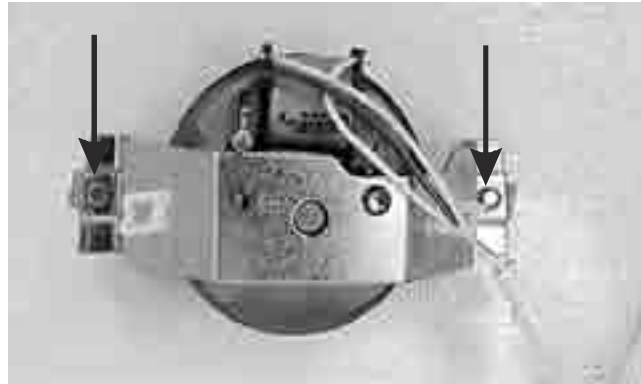

Removing the Evaporator Fan Motor:

1. Remove power from the freezer and remove the evaporator cover.
2. Disconnect the wire harness from the evaporator fan motor.
3. Using a 5/16" socket remove the (2) bolts holding the motor to the bracket and lift the motor out.

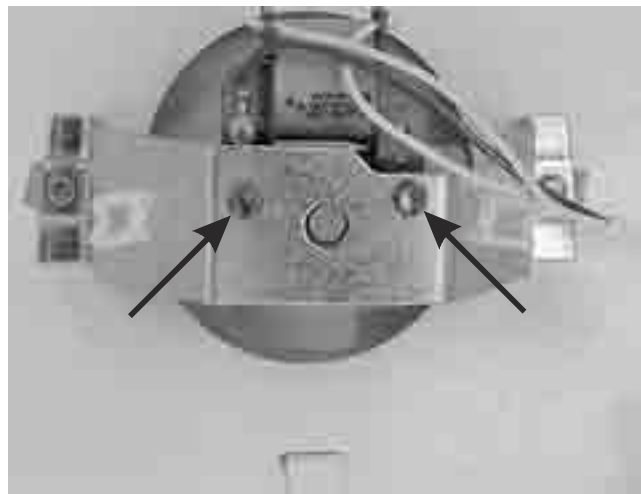

Removing the Evaporator Fan Blade:

1. Remove power from the freezer and remove the evaporator cover.
2. Remove the fan assembly.

3. Pull the fan blade off.

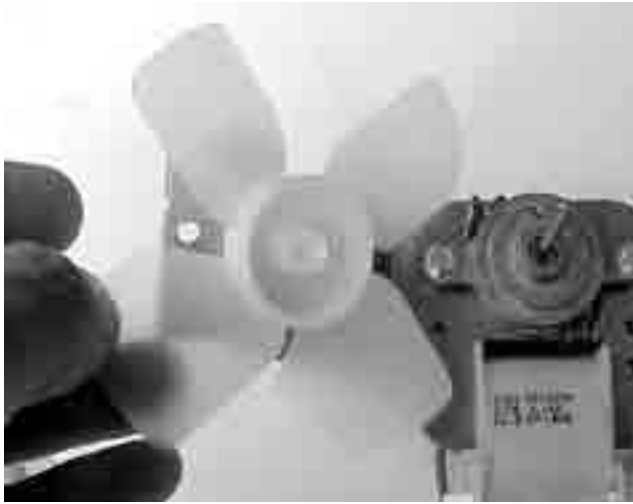

Note: When installing the fan blade, be sure to push it completely on.

Removing the Thermistor: (Deluxe Control Models)

1. Remove power from the freezer and remove the evaporator cover.
2. Remove the Phillips screw holding the thermistor to the back of the liner, then cut and splice the new thermistor into place.



Removing the Evaporator:

1. Remove power from the freezer the and remove the evaporator cover assembly.

2. Remove the defrost heater, termination thermostat and the styrofoam blocks between the evaporator and the freezer liner
3. Recover refrigerant by using EPA approved recovery system.

Note: Whenever this sealed system is opened, the filter-drier must be replaced.

CAUTION: On R-134a systems, the system must NOT be left open to the atmosphere for more than 10 minutes to prevent moisture contamination of compressor oil.

4. Remove the filter-drier.
5. Cut the suction line at the compressor.



6. Straighten the tubing, remove the foam sleeve and carefully feed the heat exchanger, through the cabinet, while pulling up on the evaporator.

Removing the Door Switch: (Standard Control Models)

1. Remove power from the freezer, raise the front of the freezer up and block it up.

2. Disconnect the wires from door switch.

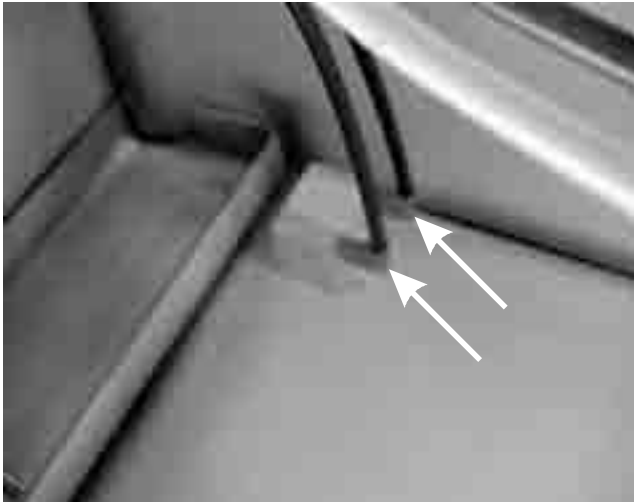

2. Disconnect the wires from door switch.

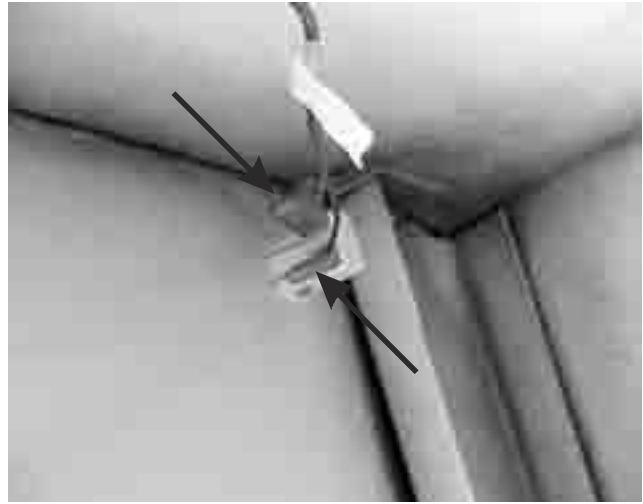

3. Press in on the locking tab on the side of the switch and push the switch out the front.



3. Press in on the locking tab on the side of the switch and push the switch out the front.

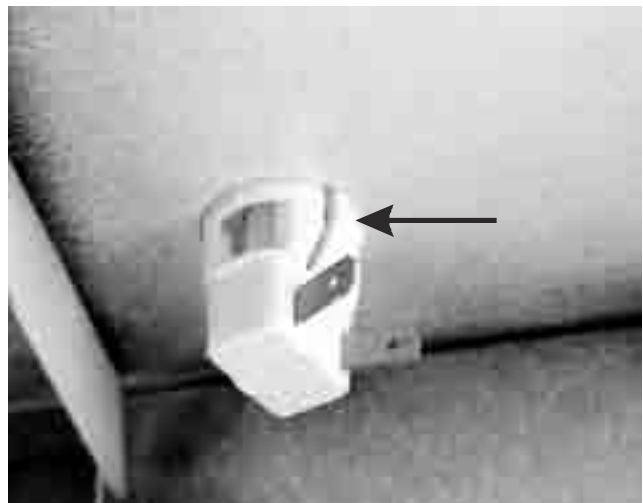

Removing the Door Switch: (Deluxe Control Models)

1. Remove power from the freezer, raise the front of the freezer up and block it up.

Disconnecting the Drain Hose:

1. The drain hose is pushed over the cabinet drain tube and the drain pan Inlet tube. To remove the hose pull it off of the cabinet drain tube and the drain pan inlet tube.

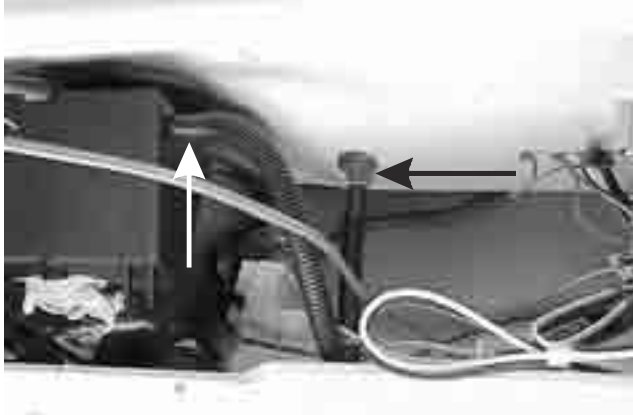

Removing the Drain Pan:

1. Remove power from the freezer, raise the front of the freezer up and block it up.
2. Release a locking tab and push the drain pan up until it clears the spring tab on the compressor. Then bring it forward, and lifted it out.

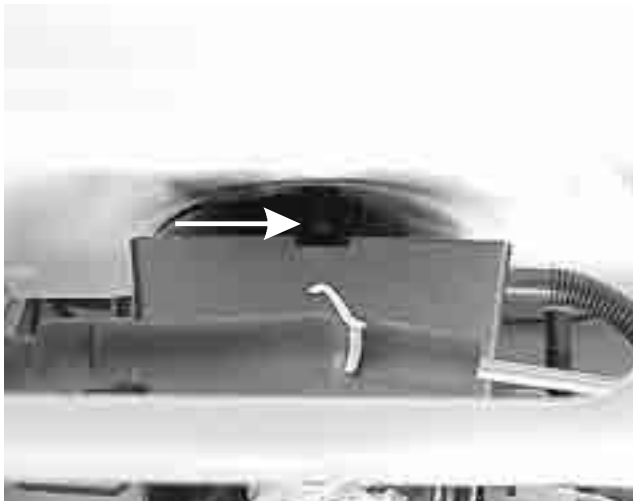

Removing the Filter-Drier:

1. Remove power and obtain access to the rear of the freezer.

CAUTION: On R-134a systems, the system must NOT be left open to the atmosphere for

more than 10 minutes to prevent moisture contamination of compressor oil.

2. Recover refrigerant by using EPA approved recovery system.

CAUTION: DO NOT un-braze old filter-drier from system. This will vaporize and drive moisture from desiccant back into system. The old filter-drier should be cut out of system.

3. Using a three corner file score and break the tube at the bottom of the filter-drier.

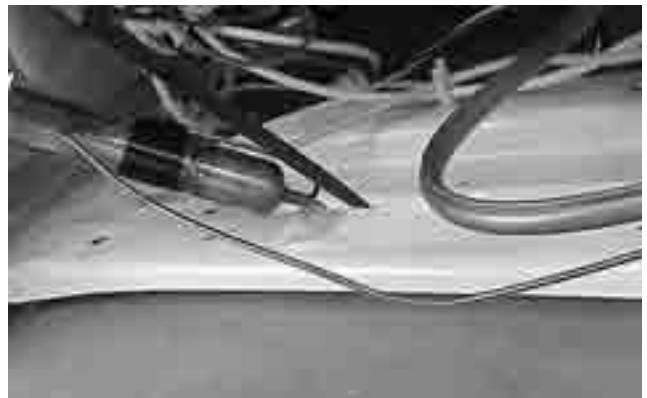

4. Remove the filter-drier by cutting the tube at the top of the filter-drier as close as possible.



Removing the Compressor Controller:

1. Remove power and obtain access to the rear of the freezer.

2. Release the plugs locking tab and disconnect the wire harness from the controller.

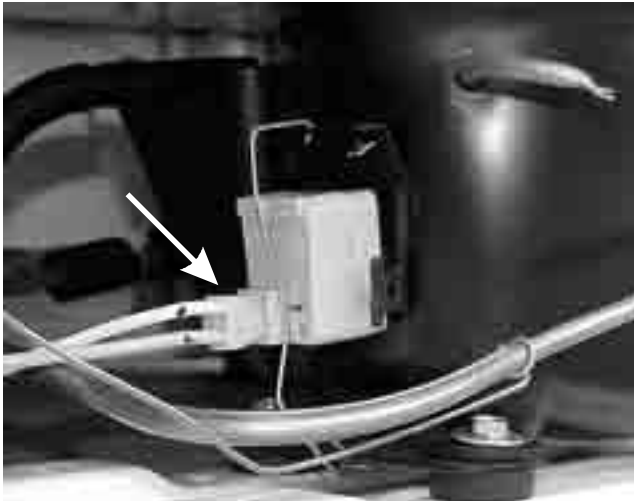

3. Using needle nose pliers remove the spring wire holding the controller to the compressor.

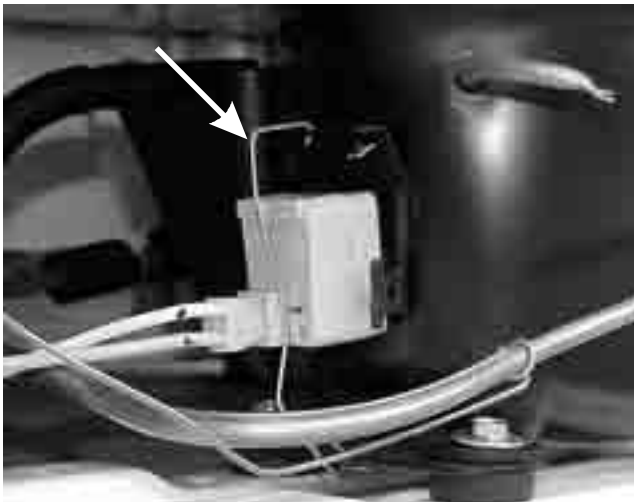

4. Pull the controller off of the compressor.

Removing the Compressor:

CAUTION: NEVER install a new compressor without first checking for possible system contamination.

To check for contamination, obtain oil sample from old compressor.

- If the oil has burned odor, but no color change or residue — install the new compressor
- If oil has a burned odor and a sugar or gritty feel

as well as showing signs of contamination (dark color) — Flush The System. Remove as much of contamination as possible from system before installing new compressor and filter-drier.

To Flush the System:

NOTE: It is recommended that system be flushed with dry Nitrogen. However, if refrigerant is used to flush the system you must look at the serial plate to see what type of refrigerant is used in the system. This is the only refrigerant that can be used to flush the system and it must be recovered.

CAUTION: Use extreme care when using Dry Nitrogen to flush systems. Pressure in nitrogen cylinder could be as high as 2000 psi. Nitrogen cylinder must be equipped with approved pressure regulator and pressure relief valve. Ensure that your hoses have adequate ratings for pressure involved and that all of your equipment is in good condition.

CAUTION: The end of the flushing hose on this tank regulator must be equipped with a hand shut-off valve. (Robinair No. 4038) Close hand shut-off valve and adjust nitrogen regulator to correct pressure before proceeding with flushing procedure.

Using Dry Nitrogen to Flush the System:

1. Remove compressor and filter-drier. Connect process coupling to outlet tube of condenser.
2. Fasten cloth over other end of coil to prevent old oil from spraying out into the room.
3. Connect hand shut-off valve on flushing hose to process coupling.
4. Slowly open hand shut-off valve and allow nitrogen to flow through condenser until discharge is clear.

CAUTION: DO NOT exceed 300 PSIG.

5. Disconnect cap tube from evaporator. Flush evaporator in same manner as condenser.

CAUTION: DO NOT exceed 150 PSIG.

6. Flush cap tube. This is only possible if you have proper service valve adaptor.

CAUTION: DO NOT exceed 300 PSIG.

7. Reassemble system.

Using Refrigerant to Flush the System:

CAUTION: Refrigerant used for flushing must be recovered into a recovery system. Meter amount of refrigerant used for flushing with your charging cylinder. DO NOT OVERFILL THE SYSTEM.

1. Disconnect the suction and discharge lines from the compressor and remove the filter-drier. Connect process coupling to outlet and inlet tube of condenser.
2. Connect hose to outlet process coupling and charging cylinder. Connect another hose to inlet coupling and recovery system.
3. Open charging cylinder and allow refrigerant to flow through condenser until discharge into bag is clear.

NOTE: To flush evaporator and heat exchanger you must remove evaporator from inside product to disconnect cap tube.

4. Disconnect capillary tube from evaporator. Flush evaporator in same manner as condenser.
5. Flush cap tube. This is only possible if you have proper service valve adaptor.
6. Reassemble system.

Installing a New Compressor:

NOTE: Entirely new compressors have been developed for use with R-134a and Ester oil refrigeration systems. Both compressor and electric motor have been modified. Old compressors intended for R-12 refrigerant must not be used for new systems charged with R-134a.

Replacement of compressor and installation of filter-drier must be done in a continuous sequence so system is exposed to atmosphere no longer than necessary.

All replacement compressors are shipped with rubber plugs in the suction, discharge and process tubes and contain the correct oil charge and a holding charge of inert gas.

Compressors have a low-side process tube attached to the compressor shell. A high-side process tube is attached to the filter-drier.

WARNING: DO NOT OPERATE RECIPROCATING COMPRESSOR WHEN CHARGING LIQUID REFRIGERANT INTO SYSTEM THROUGH ITS PROCESS TUBE.

Replacement compressors for appliances may have an oil cooler even if the original compressor did not. If the product is not equipped for an oil cooler, leave the plastic caps in place and install the compressor connecting only to the suction and discharge lines of the new compressor.

Before installing the replacement compressor remove the discharge plug and check for the pop sound of the inert gas leaving the compressor.

CAUTION: DO NOT use compressor if you do not hear this sound.

If the compressor checks OK, reinstall the plug. Do not remove any of the plugs again until the compressor is in position and you are ready to braze the lines.

CAUTION: On R-134a systems, compressor must NOT be left open to atmosphere for more than 10 minutes to prevent moisture contamination of oil.

A new compressor which is cold (e.g. after having been kept in a cold service van) should be left to warm to the surrounding temperature before the plugs on the compressor connections are removed. This will help prevent condensation from forming in the oil and the compressor. Also, avoid opening the system when any of the components or lines are cold.

NOTE: RELEASE holding charge (release slowly to avoid oil discharge) on new compressor to ensure there is no leak in seam or tubing. Reinstall rubber plug.

1. Remove electrical power from the freezer.
2. Obtain access to the rear of the freezer
3. Recover refrigerant by using EPA approved recovery system.

4. Remove the controller.

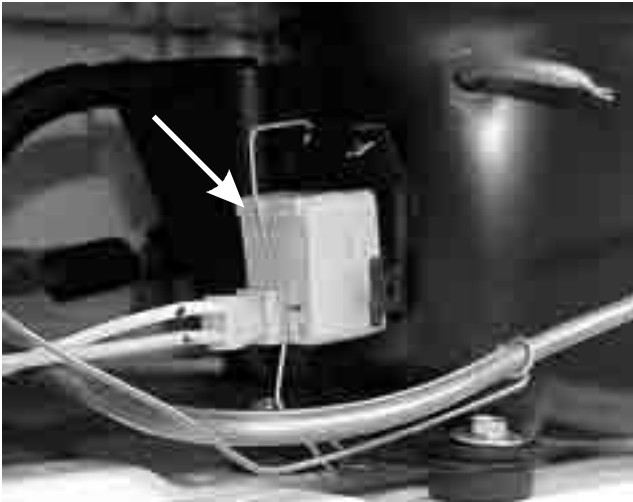

5. Using a 7/16" socket remove the (4) bolts, one in each corner, holding the compressor to the base.



6. After refrigerant is completely recovered, cut suction and discharge lines as close to compressor as possible. Leave only enough tubing to pinch off and seal defective compressor. Plug or tape any open system tubing to avoid entrance of moisture and air into system. Remove inoperable compressor and transfer mounting parts to new compressor.
7. Install new compressor in exact same manner as original compressor.
8. Reform both suction and discharge lines to align with new compressor. If they are too short, use additional lengths of tubing. Joints should overlap 0.5" to provide sufficient area for good solder joint. Clean and mark area where tubing should be cut .

Cut tubing with tubing cutter. Work as quickly as possible to avoid letting moisture and air into system.

Removing the Electronic Module: (Deluxe Control Models)

1. Remove power from the freezer.
2. Obtain access to the rear of the freezer.
3. Unplugged the wiring harnesses to the electronic module.
4. Remove the (2) Phillips screws holding the electronic module to the top of the machine compartment and lift electronic module out.

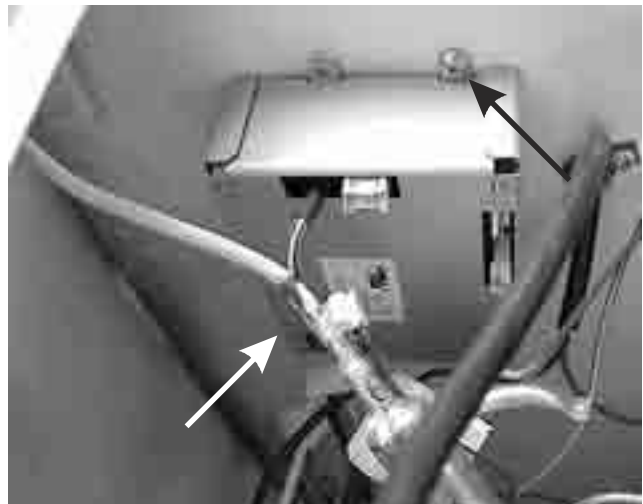

Removing the Main Breakers:

Note: The breakers are installed on the appliance before foam is added to the appliance. When the foam is added to the appliance, the foam adheres to the breakers. When removing the breakers, pieces of foam may break off and stick to the breakers. Remove any of the larger pieces from the breakers and put them back in the cabinet.

Note: The edge breakers are formed so they snap and lock to the edge of the cabinet and the edge of the liner.

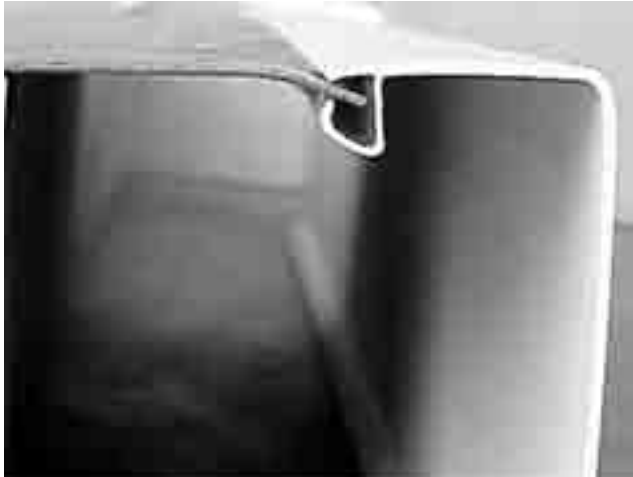

1. Using a regular putty knife, start at the middle of the breaker, and carefully worked it between the cabinet and the breaker, push it as far towards inside edge to the breaker is possible. The goal is to break the inner flange on the underside of the breaker that is attaching it to the cabinet. Worked the knife toward each end, breaking through the flange is you go.



2. Carefully peel back the breaker from the cabinet towards the inside of the unit so as to minimize the amount of foam that sticks to the breaker. Use a putty knife to remove any large pieces of foam that stick to the breaker and placed them back in the cabinet.

3. Repeat the process using a regular putty knife break the breaker flange between the inside breaker edge in the interior liner.
4. Starting in the center pull the breaker out from the freezer, using the putty knife to separate the breaker from the foam. Tried to remove as little of the foam as possible. And a large pieces of the foam that are missing need to be replaced with additional insulation.

Removing the Corner Breaker:

Note: The corner breakers are flange to except main breakers.



1. Remove one of the main breakers, that is attached to the corner breaker.
2. Using a pair of pliers pull the corner breaker away from the other main breaker.

Assembling the New Main Breaker and (2) New Corner Breakers:

1. Work the (2) corner breakers onto the existing breakers.
2. Allowing the main breaker to flex in the middle and gradually work the corner breakers and the main breaker over the cabinet and liner flanges until they lays down smoothly.
3. Seal any joints and openings with NSF-approve sealant.

SECTION I - TEARDOWN (Chest Models)

This section will describe how to remove components from the freezers. Unless stated, reverse the procedure to reinstall the component.

⚠ WARNING Always remove electrical power from the appliance when working in an area where electrical power is present.

Removing the Baskets:

1. Lift the lid and the baskets lift out.

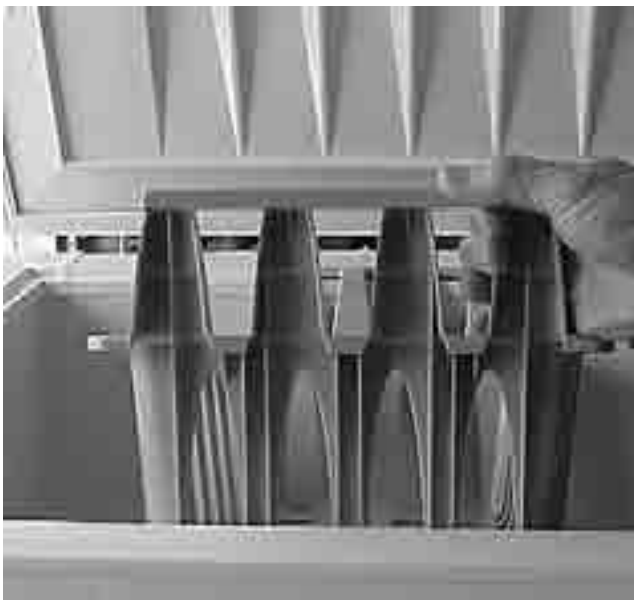

Removing the Dividers: (Some Models)

1. Lift the lid, remove the baskets and the dividers lift out.

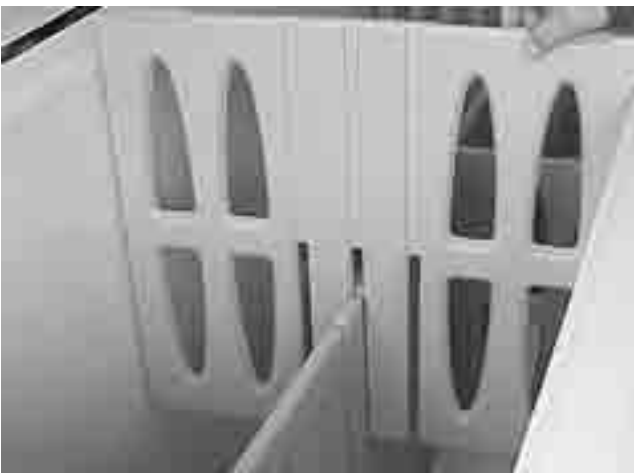

Removing the Interior Light Shield:

1. The interior light shield is snapped into the lid liner by (2) locking tabs. To release the tabs use a thin bladed object, such as a table knife, to release the tabs.
2. Lift the lid, released the tabs and pull the shield off.



Removing the Interior Light Bulb:

1. Lift the lid and turn the light bulb counterclockwise to remove it from the socket.



Releasing the Lid:

1. Disconnect electrical power from the freezer and insert a nail in each of the hinges to lock the hinges open.

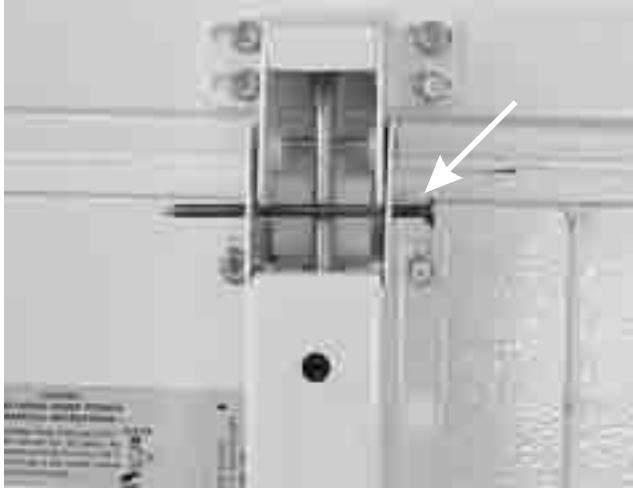

2. Using a 5/16" socket, remove the (4) screws, from each hinge, holding the upper part of the hinge to the lid.

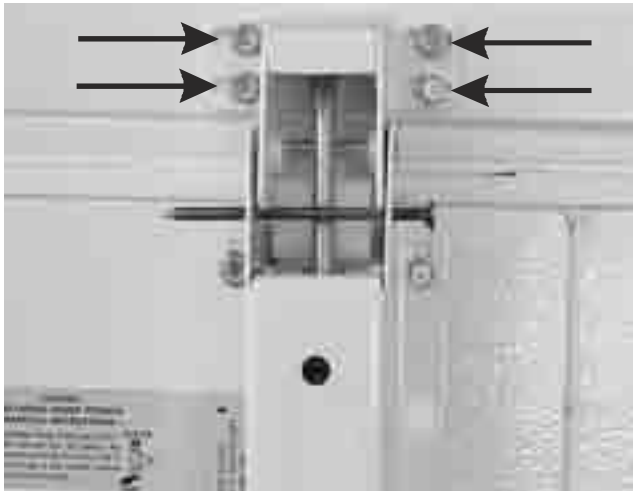

Note: The electrical cord, providing power to the lid is still connected.

3. Place something behind the freezer, that is about the same height as the freezer, and carefully lift the lid over the hinges, turn the lid over and lay the the lid on the object.

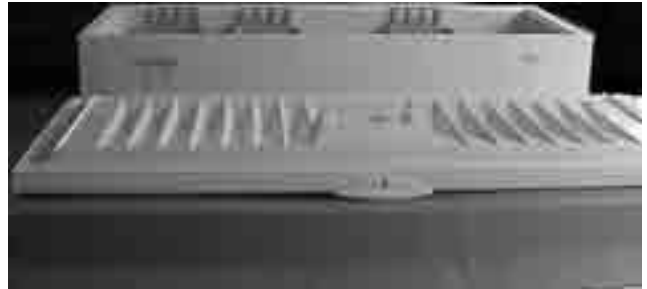

Removing Lid Inner Liner and Seal:

The lid inner liner is held to the lid outer liner by plastic rivets and (4) Phillips head screws that are hidden in by the seal.

Note: The number of plastic rivets will vary with the size of the freezer.

1. Disconnect electrical power from the freezer, released the lid and place it on the support with the inner liner up.
2. Roll the seal back and using a common screwdriver pop-out the rivets.



3. Remove the (4) Phillips screws, one in each corner, holding the inner liner to the outer liner.



4. The seal will now lift off.

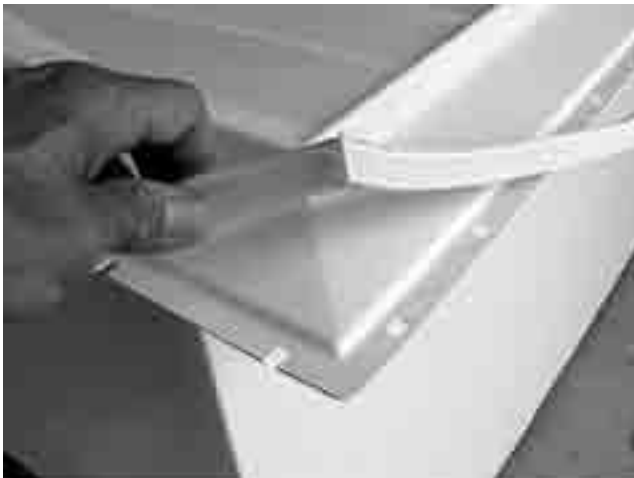

5. Remove the light shield and a light bulb, raise the inner liner and disconnect the wires from a light socket and light switch. The inner liner will now lift off.

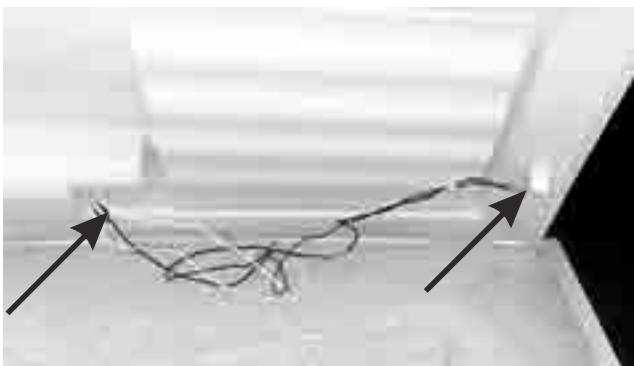

Removing Interior Light Socket:

1. Disconnect electrical power from the freezer and remove the light shield and light bulb.
2. Release the lid and remove the plastic rivets and (4) Phillips head screws holding the inner liner to the outer liner.
3. Raise the inner liner, disconnect the (2) wires from the socket. When reconnecting the wires be sure to connect the white wire to the terminal marked W.
4. Squeeze the (2) locking tabs and push the socket out of the liner.

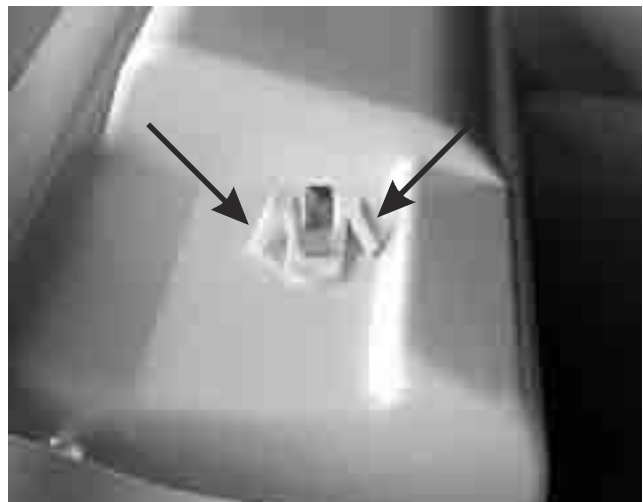

Removing Interior Light Switch:

1. Disconnect electrical power from the freezer and remove the light shield and light bulb.
2. Release the lid and remove the plastic rivets and (4) Phillips head screws holding the inner liner to the outer liner.
3. Raise the inner liner and disconnect the two wires from the switch.

4. Release the locking tab and push the socket out of the liner.

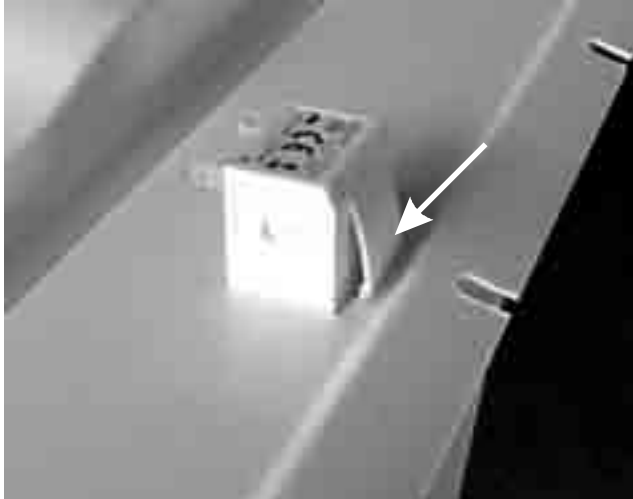

4. Remove the permagum sealing the wire harness opening.



Removing Lid Handle:

1. Disconnect electrical power from the freezer and release the inner lid liner.
2. Remove the insulation from the lid panel.
3. Using a 1/2" wrench remove the (2) nuts holding the handle to the panel.

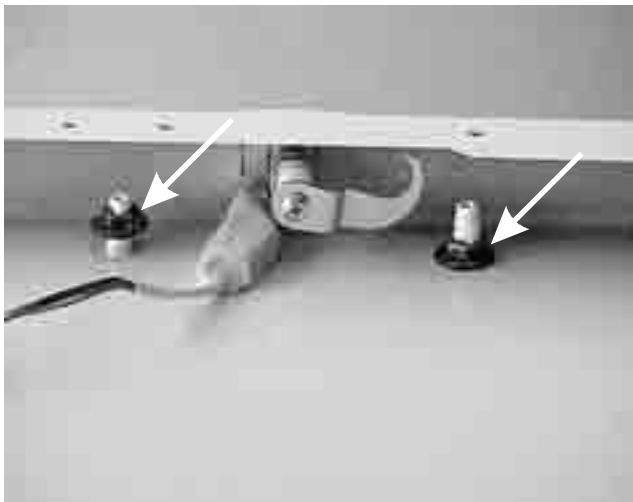

Note: Always replace the permagum when reinstalling the handle.

5. Insert a common screwdriver between the panel and the bottom of the handle and pull the handle out, so it clears the face of the locking mechanism.



6. Push down on the plastic studs to release the handle from the liner.

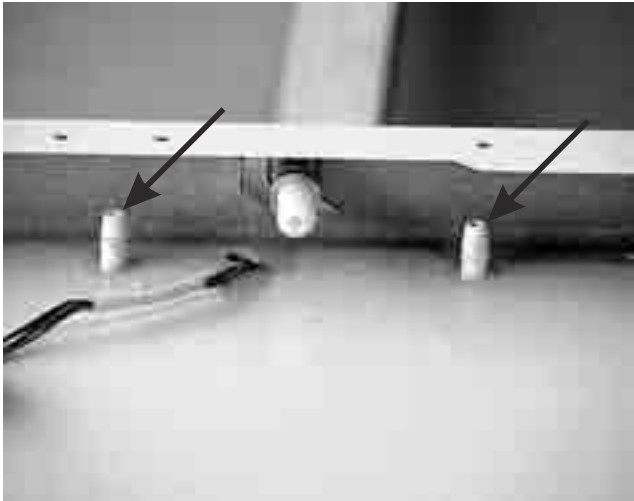

Removing Interface Board:

1. Disconnect electrical power from the freezer and remove the lid handle.
2. Using a #1 Phillips remove the (2) screws holding the board to the handle and lift the board out.



3. Unplug the wire harness from the board.

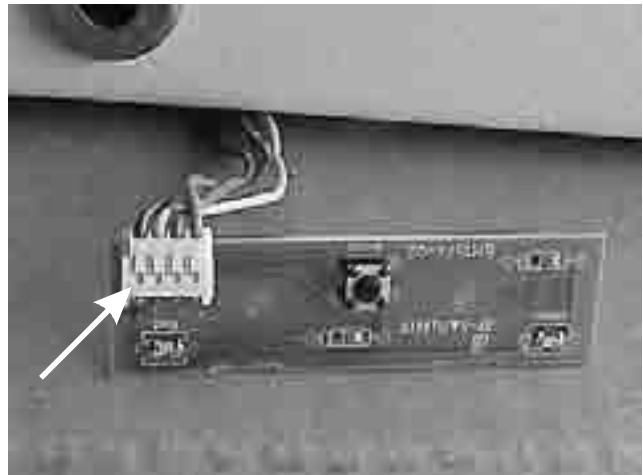

Removing Lock Latch:

1. Disconnect electrical power from the freezer and release of the inner lid liner.
2. Pull the insulation back, remove the Phillips screw holding the latch to the locking mechanism and lift the latch off.



Removing Locking Mechanism:

1. Disconnect electrical power from the freezer and remove of the lid handle.
2. Remove the latch arm.

- Using a common screwdriver release the locking fork and push the locking mechanism out the front of the panel.

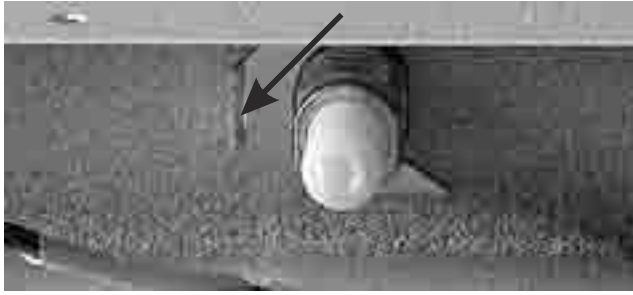

Removing Outer Lid Panel:

- Disconnect electrical power from the freezer and remove the inner lid liner.
- Remove the insulation, lid handle and the locking mechanism.
- Disconnect the wiring harness from interface board and , the green ground wire from the panel.
- Using a common screwdriver work the wiring gromit into the outer lid panel and remove the harness.



- The outer panel can now be removed.

Removing the Hinges:

- While holding in on the bottom part of the hinge, use a 5/16 " socket, to remove the (4) screws holding the bottom part of the hinge to the freezer.

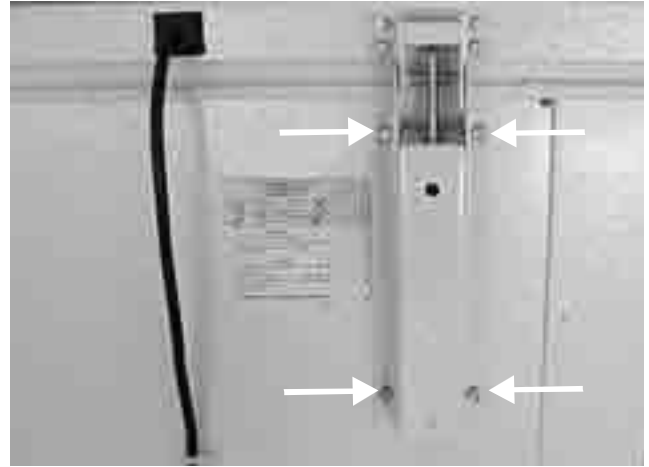

- Slowly release the pressure from the bottom part of the hinge.
- While holding the hinge, use a 5/16 " socket, to remove the (4) screws holding the hinge to the lid and lift the hinge off.

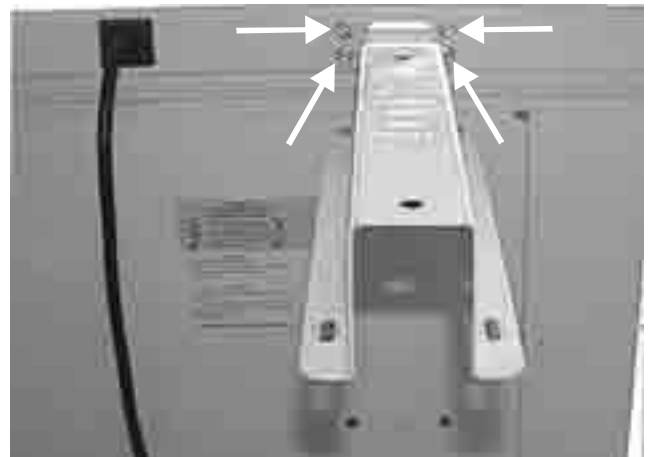

Removing the Hinges: (Alternate Method)

1. With the lid closed insert a pin or nail into the hinge to lock it closed.



The outer liner of the cabinet has a 3/16" flange and the inner liner has (2) grooves in it.

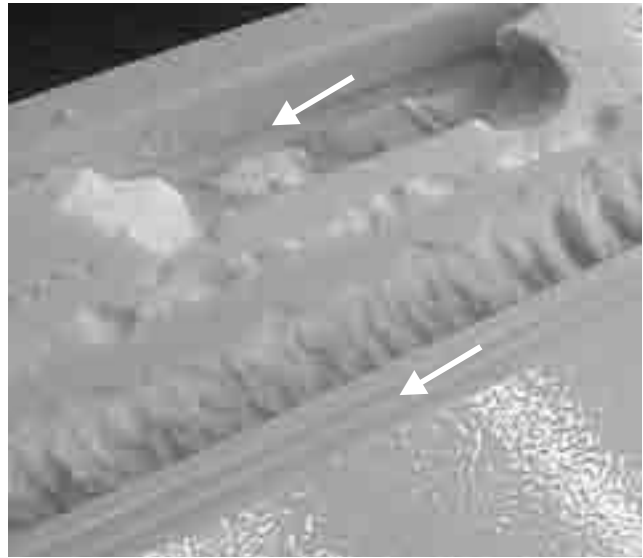

2. Using a 5/16" socket remove the (4) screws holding the hinge to the lid and the (4) screws holding the hinge to the chassis.

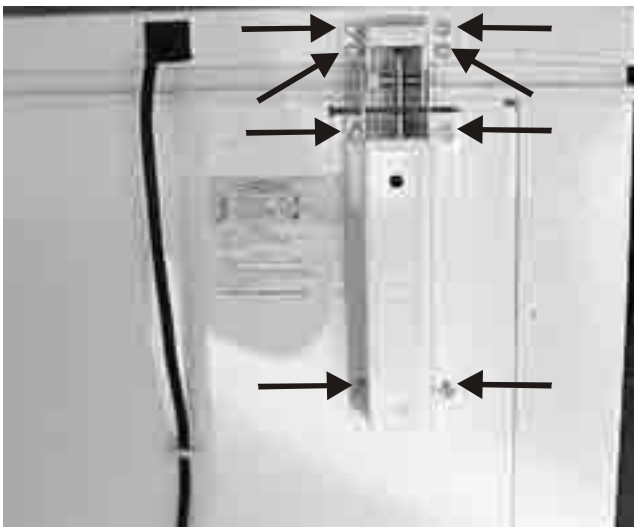

The trim has a channel with a locking tab that snaps down over the inner liner and a flange with a locking tab that snaps under the flange of the outside liner.



The end caps are formed to allow the trim to slide into them.

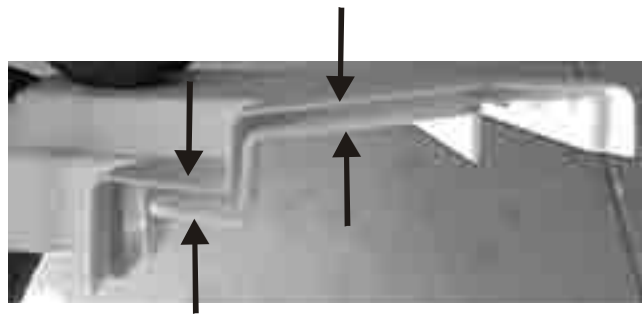

Replacing the Breaker Trim:

When the freezer is manufactured, the trim and end caps are installed before foam is added to the freezer. When foam is added to the freezer, some of the foam adheres to the trim and caps, helping to hold them in place. When a piece of trim or an end cap is removed, some of the foam will come with it. If the trim or end cap is to be reused the foam must be cleaned off.

Removing the Breaker Trim:

1. Lift the lid and start at the inside center, lift up and out on the trim to disengage it from the inside liner. Then pull up and out on the trim to disengage it from the foam, and the flange of the outer cabinet liner.



2. Once the trim has been disengaged from the liners and the foam, bow the center of the trim up to disengage from the end cap.

Removing the End Caps:

1. Remove the lid.
2. Remove one the pieces of trim connect to the end cap.
3. Lift up on the front edge of the end cap, that is in line with the remaining piece of trim, and slide it off.



Removing the Internal Drain Cap:

1. Raise the lid and slide the baskets to the left.
2. The drain cap lifts off.



Removing the External Drain Cap:

1. The drain cap pulls off.



Removing the Cold Control Knob:

1. The cold control knob pulls off.



2. Disconnect the wire harness to the cold control.

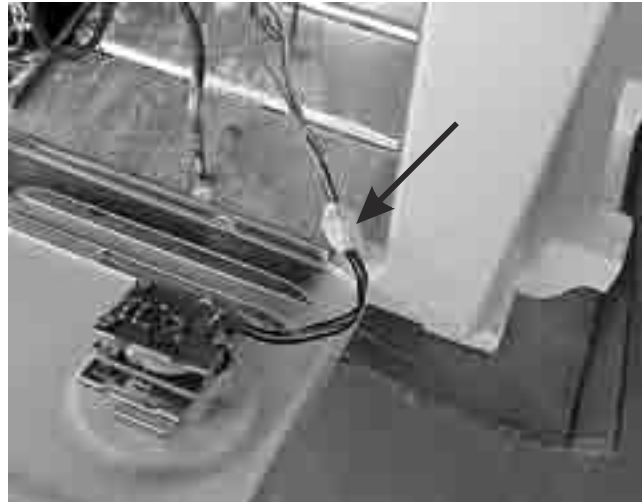

3. Push down on the control to release the spring-loaded tabs from the machine compartment cover and lift the control out.

Releasing the Machine Compartment Cover:

1. Disconnect electrical power.
2. Remove the (2) Phillips screws holding the machine compartment cover to the outer liner.
3. Pull out on the top of the cover.

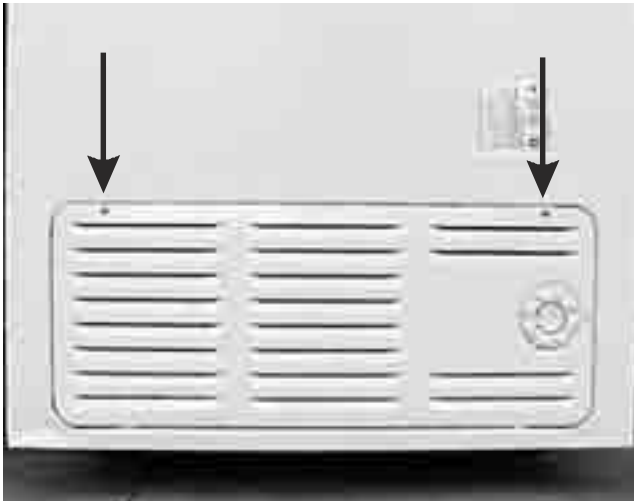

Removing the Machine Compartment Cover:

1. Disconnect power and release the machine compartment cover.

Removing the Cold Control:

1. Disconnect power and release the machine compartment cover.

2. Release the cold control and lift the cover out of the slots.

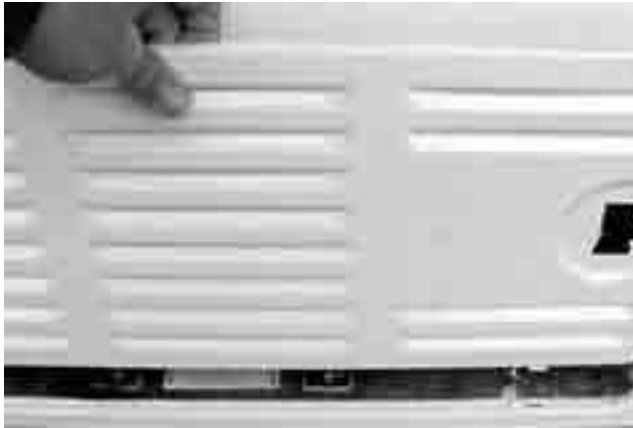

3. Pull the thermistor out of the tube.

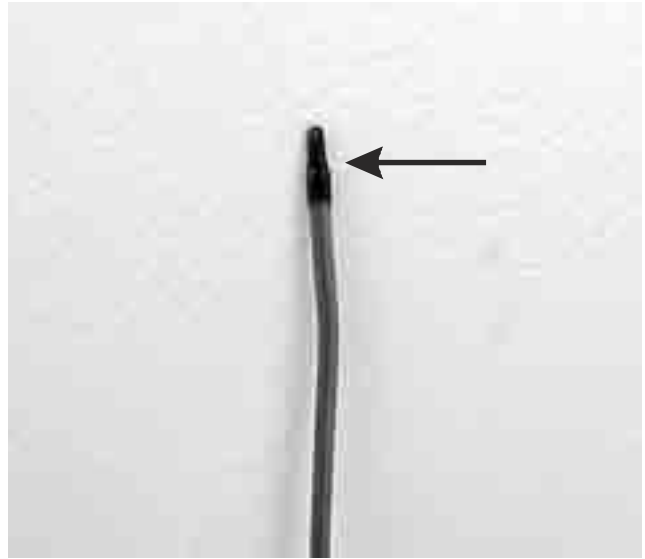

Removing the Thermistor:

1. Disconnect power and release the machine compartment cover.
2. Remove the permagum from the base of the tube in which the thermistor is inserted.

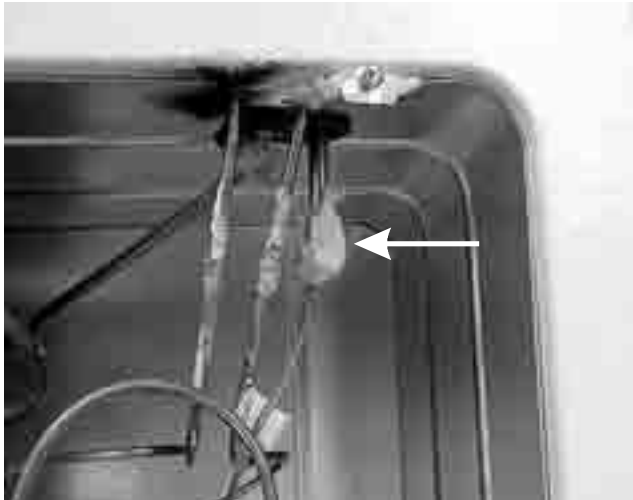

Note: When replacing the thermistor, cut and splice the new thermistor into the circuit.

Removing the Electronic Module:

1. Disconnect power and remove the machine compartment cover.
2. Unplug the wire harnesses from the module.
3. Remove the (2) Phillips screws holding the module to the back wall of the machine compartment and lift the module out.

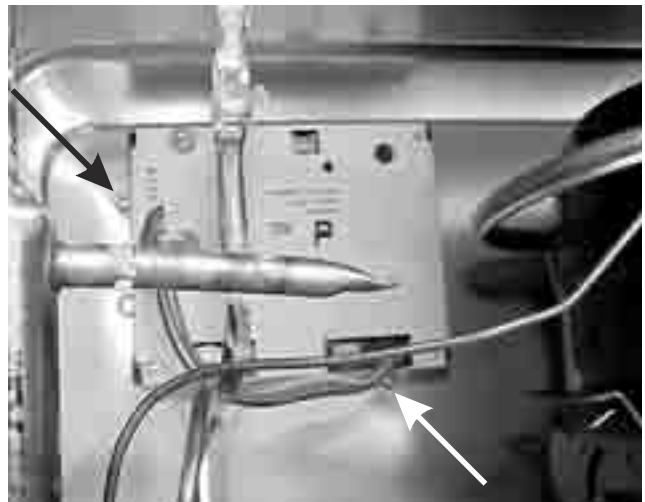

Removing the Run Capacitor and Controller Assembly:

1. Disconnect electrical power and remove the machine compartment cover.
2. Unplugged the wires from the controller and release the spring wire clip holding the run capacitor and controller assembly to the compressor.

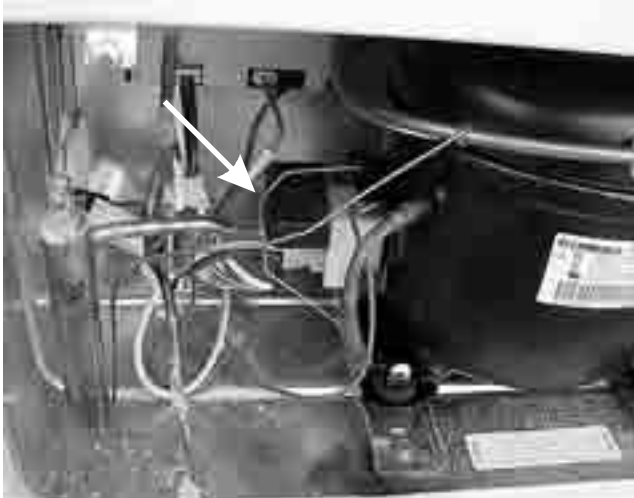

3. Pull the controller off of the compressor and slide the capacitor off of the controller.



Removing the Filter-Drier:

1. Disconnect power from the freezer and remove the machine compartment cover.

CAUTION: On R-134a systems, the system must NOT be left open to the atmosphere for more than 10 minutes to prevent moisture contamination of compressor oil.

2. Recover refrigerant by using EPA approved recovery system.

CAUTION: DO NOT un-braze old filter-drier from system. This will vaporize and drive moisture from desiccant back into system. The old filter-drier should be cut out of system.

3. Using a three corner file score and break the tube at the bottom of the filter-drier.

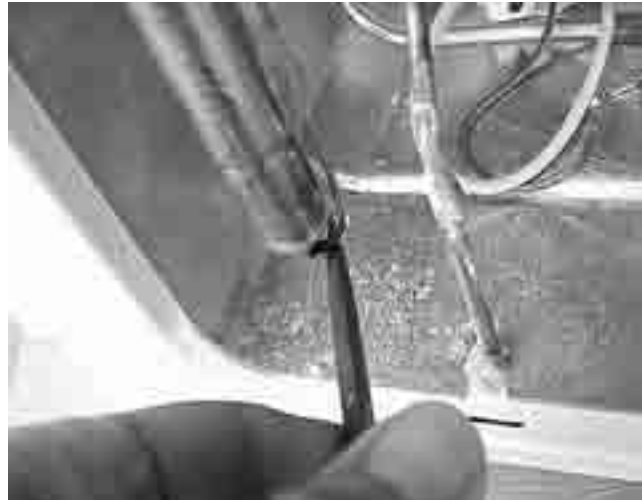

4. Remove the filter-drier by cutting the tube at the top of the filter-drier as close as possible.



Replacing the Compressor:

CAUTION: NEVER install a new compressor without first checking for possible system contamination.

To check for contamination, obtain oil sample from old compressor.

- If the oil has burned odor, but no color change or residue — install the new compressor
- If oil has a burned odor and a sugar or gritty feel as well as showing signs of contamination (dark color) — Flush The System. Remove as much of contamination as possible from system before installing new compressor and filter-drier.

To Flush the System:

NOTE: It is recommended that system be flushed with dry Nitrogen. However, if refrigerant is used to flush the system you must look at the serial plate to see what type of refrigerant is used in the system. This is the only refrigerant that can be used to flush the system and it must be recovered.

CAUTION: Use extreme care when using Dry Nitrogen to flush systems. Pressure in nitrogen cylinder could be as high as 2000 psi. Nitrogen cylinder must be equipped with approved pressure regulator and pressure relief valve. Ensure that your hoses have adequate ratings for pressure involved and that all of your equipment is in good condition.

CAUTION: The end of the flushing hose on this tank regulator must be equipped with a hand shut-off valve. (Robinair No. 4038) Close hand shut-off valve and adjust nitrogen regulator to correct pressure before proceeding with flushing procedure.

Using Dry Nitrogen to Flush the System:

1. Remove compressor and filter-drier. Connect process coupling to outlet tube of condenser.
2. Fasten cloth over other end of coil to prevent old oil from spraying over room.
3. Connect hand shut-off valve on flushing hose to process coupling.
4. Slowly open hand shut-off valve and allow nitrogen to flow through condenser until discharge is clear.

CAUTION: DO NOT exceed 300 PSIG.

5. Reassemble system.

Using Refrigerant to Flush the System:

CAUTION: Refrigerant used for flushing must be recovered into a recovery system. Meter the amount of refrigerant used for flushing with your charging cylinder. DO NOT OVERFILL THE SYSTEM.

1. Disconnect the suction and discharge lines from the compressor and remove the filter-drier. Connect process coupling to outlet and inlet tube of condenser.
2. Connect hose to outlet process coupling and charging cylinder. Connect another hose to inlet coupling and recovery system.
3. Open charging cylinder and allow refrigerant to flow through condenser until discharge into bag is clear.
4. Reassemble system.

Installing a New Compressor:

NOTE: Entirely new compressors have been developed for use with R-134a and Ester oil refrigeration systems. Both compressor and electric motor have been modified. Old compressors intended for R-12 refrigerant must not be used for new systems charged with R-134a.

Replacement of compressor and installation of filter-drier must be done in a continuous sequence so system is exposed to atmosphere no longer than necessary.

All replacement compressors are shipped with rubber plugs in the suction, discharge and process tubes and contain the correct oil charge and a holding charge of inert gas.

Compressors have a low-side process tube attached to the compressor shell. A high-side process tube is attached to the filter-drier.

WARNING: DO NOT OPERATE RECIPROCATING COMPRESSOR WHEN CHARGING LIQUID REFRIGERANT INTO SYSTEM THROUGH ITS PROCESS TUBE.

Replacement compressors for freezer may have an oil cooler even if the original compressor did not. If the product is not equipped for an oil cooler, leave the plastic caps in place and install the compressor connecting only to the suction and discharge lines of the new compressor.

Before installing the replacement compressor remove the discharge plug and check for the pop sound of the inert gas leaving the compressor.

CAUTION: DO NOT use compressor if you do not hear this sound.

If the compressor checks OK, reinstall the plug. Do not remove any of the plugs again until the compressor is in position and you are ready to braze the lines.

CAUTION: On R-134a systems, compressor must NOT be left open to atmosphere for more than 10 minutes to prevent moisture contamination of oil.

A new compressor which is cold (e.g. after having been kept in a cold service van) should be left to warm to the surrounding temperature before the plugs on the compressor connections are removed. This will help prevent condensation from forming in the oil and the compressor. Also, avoid opening the system when any of the components or lines are cold.

NOTE: RELEASE holding charge (release slowly to avoid oil discharge) on new compressor to ensure there is no leak in seam or tubing. Reinstall rubber plug.

1. Disconnect electrical supply to freezer.
2. Remove machine compartment panel.
3. Recover refrigerant by using EPA approved recovery system.

4. Remove the controller and run capacitor from the compressor and unplug the ground wire.

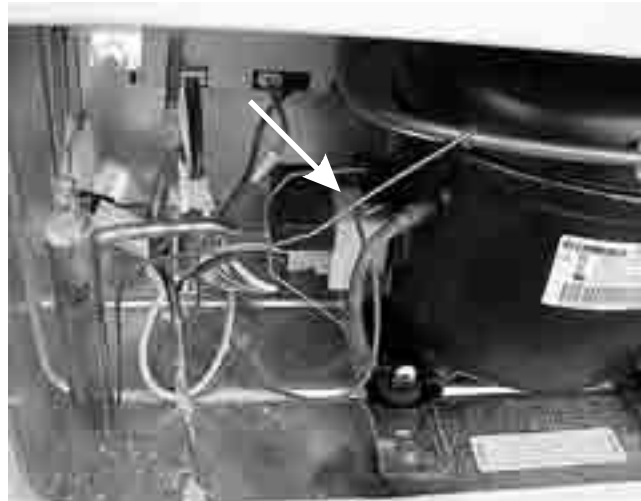

6. Remove mounting clips and washers.



7. After refrigerant is completely recovered, cut suction and discharge lines as close to compressor as possible. Leave only enough tubing to pinch off and seal defective compressor. Plug or tape any open system tubing to avoid entrance of moisture and air into system. Remove inoperable compressor and transfer mounting parts to new compressor.
8. Install new compressor in exact same manner as original compressor.
9. Reform both suction and discharge lines to align with new compressor. If they are too short, use additional lengths of tubing. Joints should overlap 0.5" to provide sufficient area for good solder joint. Clean and mark area where tubing should be cut. Cut tubing with tubing cutter. Work as quickly as possible to avoid letting moisture and air into system.

NOTE: If low-side process tube is too short, silver solder four inch piece of tubing onto process tube at this time.

10. Solder all connections.

13. Replace the original filter-drier.

CAUTION: DO NOT un-braze old filter-drier from system. This will vaporize and drive moisture from desiccant back into system. The old filter-drier should be cut out of system.

15. Evacuate and charge system using recommended procedure described under Evacuating and Recharging.

Replacing the Condenser:

The condenser is foamed in place and is not accessible for repair. However, repair can be made by installing a service replacement condenser kit. Refer to the appropriate part list of the model been service for the correct kit part number.

Each service replacement condenser kit consists of: a condenser assembly that can be installed on the back of the cabinet, mounting hardware, replacement filter-drier and a complete installation instructions.

To install, use the following procedure:

1. Disconnect unit from source of power.
2. Recover refrigerant by using EPA approved recovery system.
3. Installed the replacement condenser in accordance with the instructions included with the kit.
4. Evacuate and charge a system using the recommended procedure described under evacuation and recharging found in section D.

