

Envirovault

30 YEAR
WARRANTY



Fuel Protection You Can Depend On

Our design ...

with 6" of lightweight concrete between the inner and outer tanks, provides the best environmental protection, fire protection, and impact resistance.

- Meets requirements for secondary containment, leak monitoring, spill containment, and overfill protection.
- UL 2085 listed – Protected Aboveground Tank for Flammable and Combustible Liquids
- Inner Tank fabricated from minimum 3/16" steel and UL-142 listed – Steel Aboveground Tank for Flammable and Combustible Liquids
- 6" lightweight concrete vaulting between inner and outer tank provides minimum two-hour fire rating.
- High-build polyester glassflake coating is same coating used for saltwater submersion protection on offshore platforms
- Fittings and protrusions are stainless steel
- Each tank Quality Control inspected and pressure tested
- Exceeds liability insurance requirements

Options

- OSHA access steps with handrails
- Cold weather heaters
- Standard color gray, optional colors available



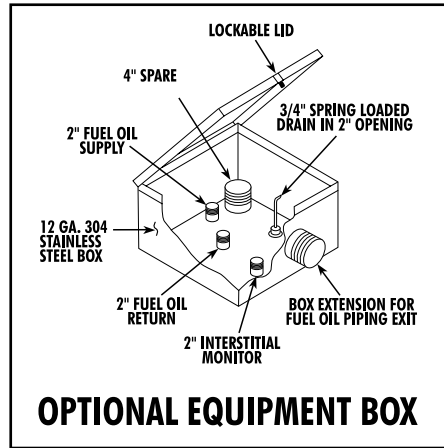
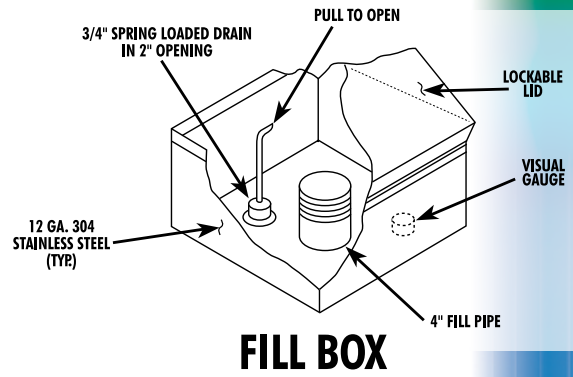
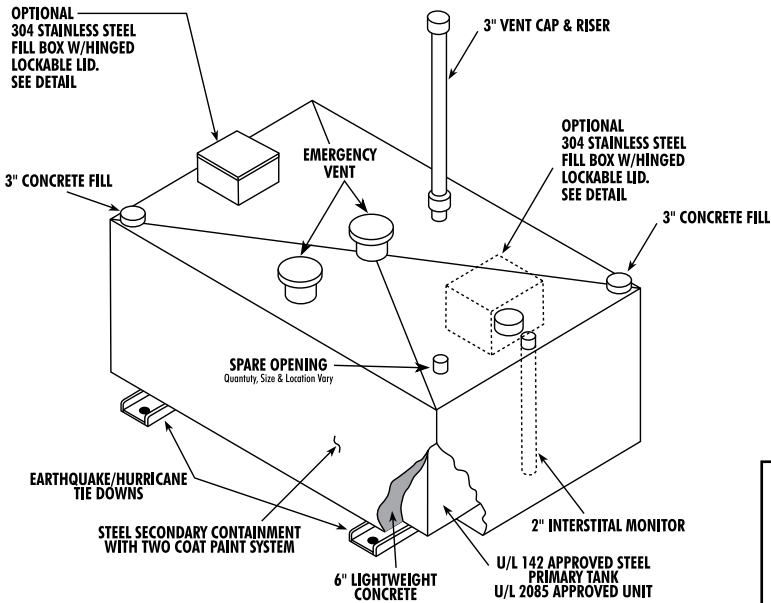

A better idea for fuel storage

- No exposed concrete
- Designed to meet or exceed national and local codes
- Available in sizes from 250 to 30,000 gallons
- Custom dimensions are available
- True double-wall steel protection for secondary containment

Model #/Capacity	Standard Dimensions L x W x H
EV-250 250 gal.	58" x 48" x 51"
EV-500 500 gal.	92" x 52" x 51"
EV-650 650 gal.	116" x 52" x 51"
EV-1000 1000 gal.	132" x 66" x 51"
EV-1500 1500 gal.	120" x 80" x 63"
EV-2000 2000 gal.	156" x 80" x 63"
EV-2500 2500 gal.	157" x 88" x 67"
EV-3000 3000 gal.	184" x 88" x 67"
EV-4000 4000 gal.	242" x 88" x 67"
EV-5000 5000 gal.	299" x 88" x 67"
EV-6000 6000 gal.	219" x 96" x 94"
EV-8000 8000 gal.	288" x 96" x 94"
EV-10000 10000 gal.	356" x 96" x 94"
EV-12000 12000 gal.	426" x 96" x 94"
EV-15000 15000 gal.	420" x 96" x 118"
EV-20000 20000 gal.	420" x 120" x 122"
EV-25000 25000 gal.	423" x 144" x 122"
EV-30000 30000 gal.	423" x 144" x 146"

Compartment tanks are available in all sizes. Ask for details.

- Engineered for Seismic 4 rating
- Earthquake/hurricane tie-downs
- Top fill or remote fill
- Meets NFPA 30 and 30A
- Leak detection space provided
- Primary and emergency vents
- UL Certified ballistic and vehicle impact protection
- 30 year warranty includes primary and secondary tank as well as concrete vaulting
- UL 2085 listed and labeled
- CARB approved



phoenix products™

phoenix.sales@phoenixprods.com • www.phoenixprods.com

1727 Bennett St. • Jacksonville, FL 32206 • 904-354-1858 • Fax 904-354-7929