



EZswitch Series

User's Manual

Version 1.0
October 2010
EZswitch-0A-v1.0-E

Disclaimer

Information in this document is subject to change without notice. The manufacturer does not make any representations or warranties (implied or otherwise) regarding the accuracy and completeness of this document and shall in no event be liable for any loss of profit or any other commercial damage, including but not limited to special, incidental, consequential, or other damages.

No part of this document may be reproduced or transmitted in any form by any means, electronic or mechanical, including photocopying, recording or information recording and retrieval systems without the express written permission of the manufacturer.

All brand names and product names used in this document are trademarks, or registered trademarks of their respective holders.

FCC Statement

This device generates and uses radio frequency and may cause interference to radio and television reception if not installed and used properly. This has been tested and found to comply with the limits of a Class B computing device in accordance with the specifications in Part 15 of the FCC Rules. These specifications are designed to provide reasonable protection against such interference in a residential installation. However, there is no guarantee that interference will not occur in a particular installation. If this device does cause harmful interference to radio or television reception, which can be determined by plugging the device in and out, the user can try to correct the interference by one or more of the following measures:

- Reorient or relocate the receiving antenna.
- Increase the separation between the device and receiver.
- Connect the computer into an outlet on a circuit different from that to which the receiver is connected.
- Consult the dealer or an experienced radio/TV technician for help.



Contents

1.	INTRODUCTION	1
2.	SPECIFICATION	2
3.	SYSTEM REQUIREMENTS	3
4.	INSTALLATION	3
4.1.	FRONT VIEW	3
4.2.	REAR VIEW	4
4.3.	INSTALL A KVM SWITCH (SINGLE-TIER INSTALLATION)	4
4.3.1.	<i>Installation Guidelines</i>	4
4.3.2.	<i>Console Connection</i>	4
4.3.3.	<i>System Connection</i>	5
4.4.	CASCADE KVM SWITCHES (MULTI-TIER INSTALLATION)	7
4.5.	FIRMWARE UPGRADE PORT	9
4.6.	RACK-MOUNT THE KVM SWITCH	9
5.	OPERATION	9
6.	HOT KEY OPERATION	10
6.1.	TRIGGER THE OSD MENU	10
6.2.	SET THE LEADING HOT KEY	10
6.3.	CHANNEL SELECTION IN A SINGLE-TIER KVM SYSTEM	10
6.3.1.	<i>Select a Specific Channel</i>	10
6.3.2.	<i>Channel Switching Using Arrow Keys</i>	11
6.3.3.	<i>Channel Switching Using the <ALT> Key</i>	11
6.4.	CHANNEL SELECTION IN A MULTI-TIER KVM SYSTEM	12
6.5.	DISABLE OR ENABLE THE BUZZER	13
6.6.	AUTO-SCAN FUNCTION	13
6.6.1.	<i>Enable the Auto-Scan Function</i>	13
6.6.2.	<i>Disable the Auto-Scan Function</i>	14
6.6.3.	<i>Different Auto-Scan Modes</i>	14
6.6.4.	<i>Auto-Scan Time Interval</i>	14
6.7.	CONSOLE LOCK	15
7.	OSD OPERATION	15
7.1.	OSD MAIN MENU	15
7.1.1.	<i>Tier Number</i>	15
7.1.2.	<i>Channel Name</i>	15
7.1.3.	<i>Computer & KVM Switch Status</i>	16

7.1.4.	<i>Currently Selected Channel Number</i>	16
7.1.5.	<i>Parent Channel Number</i>	17
7.1.6.	<i>Page Down / Up Indicator</i>	17
7.1.7.	<i>Function Keys Menu</i>	17
7.2.	CHANNEL SELECTION USING THE OSD	17
7.2.1.	<i>Select a Channel</i>	17
7.2.2.	<i>Select a Second- or Third-Tier Channel</i>	18
7.2.3.	<i>Return to the Upper-Tier OSD</i>	18
7.3.	SETUP MENU	18
7.3.1.	<i>Scan Mode</i>	19
7.3.2.	<i>Scan Time</i>	19
7.3.3.	<i>Banner Time</i>	19
7.3.4.	<i>Position</i>	19
7.3.5.	<i>Hot Key</i>	20
7.3.6.	<i>Sound</i>	20
7.3.7.	<i>Language</i>	20
7.4.	AUTO-SCAN USING THE OSD	21
7.4.1.	<i>Enable the Auto-Scan Function</i>	21
7.4.2.	<i>Disable the Auto-Scan Function</i>	21
7.4.3.	<i>Different Auto-Scan Modes</i>	22
7.4.4.	<i>Auto-Scan Time Interval</i>	22
7.5.	CONSOLE LOCK USING THE OSD	22
7.6.	RENAME A CHANNEL	23
7.7.	SECURITY SETUP	23
7.7.1.	<i>Security Mode Login</i>	23
7.7.2.	<i>Security Mode</i>	24
7.7.3.	<i>Change the Administrator Password</i>	24
7.7.4.	<i>User Account Settings</i>	25
7.7.5.	<i>User Authorization Settings</i>	25
7.8.	PORT LOCK	26
7.8.1.	<i>Lock a Channel Port</i>	26
7.8.2.	<i>Select a Locked Channel</i>	27
7.8.3.	<i>Unlock a Channel Port</i>	27
7.9.	EXIT OSD	27
8.	SPECIAL SUN KEY EMULATION	28
9.	TROUBLESHOOTING	29
10.	FIRMWARE UPGRADE	30

11. TIERING WITH DOMINION KX II.....	35
11.1. CONNECT EZSWITCH TO DOMINION KX II.....	35
11.2. CONFIGURE DOMINION KX II.....	35
11.3. REMOTE ACCESS TO AN EZSWITCH CHANNEL.....	37
12. KEYBOARD AND MOUSE COMPATIBILITY.....	38
12.1. MOUSE COMPATIBILITY TABLE.....	38
12.2. KEYBOARD COMPATIBILITY TABLE.....	43

1. Introduction

Thank you for purchasing EZswitch, an 8-port or 16-port keyboard/video/mouse (KVM) switch. The product enables you to control 8 or 16 computers or servers from one console with PS/2 or USB input devices and a regular monitor.

● Features

- Supports the PS/2 and USB keyboard and mouse
- Computer connection via PS/2 or USB interface
- Fully compliant with the USB 1.1/ 2.0 specification
- Multi-platform support, including Windows, Linux, Mac OS9/OSX, and Sun Microsystems
- Supports VGA resolutions up to 2048 x 1536
- Intuitive On-Screen-Display (OSD) interface for simple operation
- Supports chain cascading function on the OSD
- Expands to 4,096 computers via a 3-tier daisy chaining configuration (using 16-port KVM switches)
- No special configuration required for cascading KVM switches
- Supports tiering with Raritan's Dominion® KX II models (see the section "11. Tiering with Dominion KX II")
- Emulates a PS/2 or USB keyboard on each connected computer for normal boot without any keyboard error
- Hot swappable components with no impact on the operation
- Quick channel switching through:
 - Push buttons on the KVM switch
 - Hot keys using the keyboard
 - OSD interface
- Auto-scan function for automatically cycling through all channels
- An LED display for computer status monitoring
- Provides a beeper for indication of channel switching
- Rack-mountable in a 19" system rack (1U)
- Firmware upgradeable

● Package Contents

The product package includes the following items:

- One 8-port or 16-port EZswitch
- One user's manual (with warranty card included)
- One power adaptor
- One rackmount bracket kit
- Custom KVM cables

2. Specification

Specification		
Maximum number of computers	8 or 16	
Channel selection	Push buttons, hot key or OSD interface	
LEDs	Red ones for indicating the computer selection Green ones for indicating the computer accessibility	
Channel ports:	Video	8 or 16 HDB-15 female connectors
	(KB/MS)	(PS/2 & USB signals combined)
Console ports:	PS/2 keyboard	One 6-pin mini-DIN female connector
	PS/2 mouse	One 6-pin mini-DIN female connector
	Video	One HDB-15 female connector
	USB keyboard	One USB A type female connector
	USB mouse	One USB A type female connector
Auto-Scan interval	Adjustable via the OSD	
DDC, DDC2 monitor resolution	Up to 2048 x1536@65Hz	
Hot swappable	Yes	
Operating systems	Windows 98SE/Me/2000/XP/2003/Vista/7, Linux, Mac OS9/OSX and Sun Microsystems	
Power supply	External power adaptor	
Dimensions (L x W x H)	44 x 15.7 x 4.5 cm (17.3 x 6.1 x 1.5 inch)	
Weight	1750g / 1900g	
Housing material	Metal	
Operating temperature	32~122°F (0~50°C)	
Humidity	0%~80%RH	
Firmware upgrade port	Mini USB female	

3. System Requirements

- **Console Requirements:**

- A VGA, SVGA or Multisync monitor with high resolution capability
- PS/2 or USB keyboard and mouse

- **Computer (Server) Requirements:**

- Equipped with a VGA, SVGA or Multisync video card
- Equipped with USB A type ports or PS/2 6-pin mini-DIN connectors for keyboard and mouse

- **Cable Requirements:**

- Custom KVM cables

Note: To purchase these cables, contact your dealer or Raritan.

4. Installation

4.1. Front View

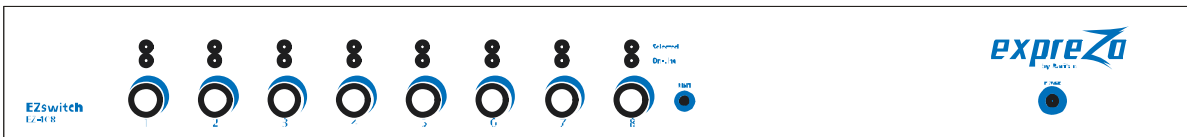

Figure 1: Front view of the 8-port switch

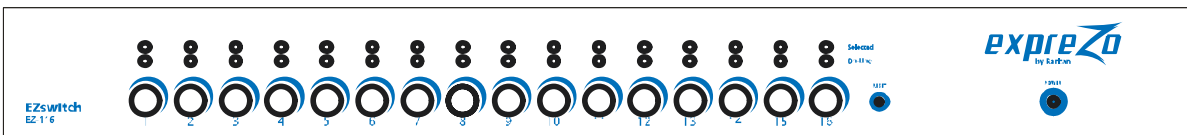

Figure 2: Front view of the 16-port switch

- **LED Indicators:**

- “Selected” LEDs:
A lit RED LED indicates that the computer connected to the corresponding channel is selected.
- “On-Line” LEDs:
A lit GREEN LED indicates that a computer is physically connected to the corresponding channel and is ready to access.

- **Reset Switch:**

Press the Reset switch when you want to reset the system. This switch must be pressed with a pointed object, such as a paper clip or a ball-point pen.

4.2. Rear View

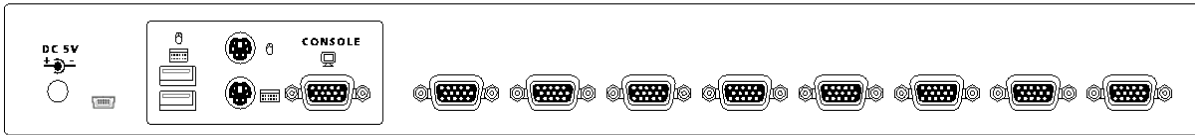

Figure 3: Rear view of the 8-port switch

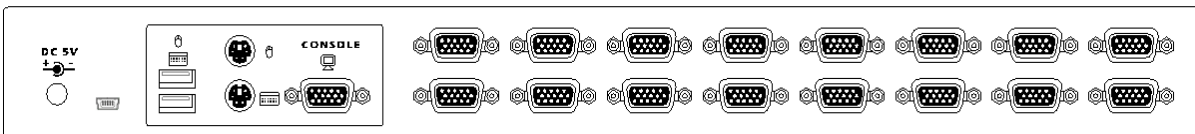

Figure 4: Rear view of the 16-port switch

4.3. Install a KVM Switch (Single-Tier Installation)

4.3.1. Installation Guidelines

- All computers and devices must be turned OFF prior to installation.
- Disconnect power cords from the computers implemented with the Keyboard Power On function prior to installation, or the KVM switch may not work properly.
- Computers running Windows 98 must be connected to a KVM switch via PS/2 ports because Windows 98 does not support initial installation through the USB HID driver.
- Old computers may require USB setting adjustment in the BIOS to enable the USB interface.
- There is no guarantee that the EZswitch KVM switch can fully support a USB keyboard via a USB hub.

4.3.2. Console Connection

Connect a keyboard, mouse and monitor to the console ports on the rear panel of EZswitch (see *Figure 5*).

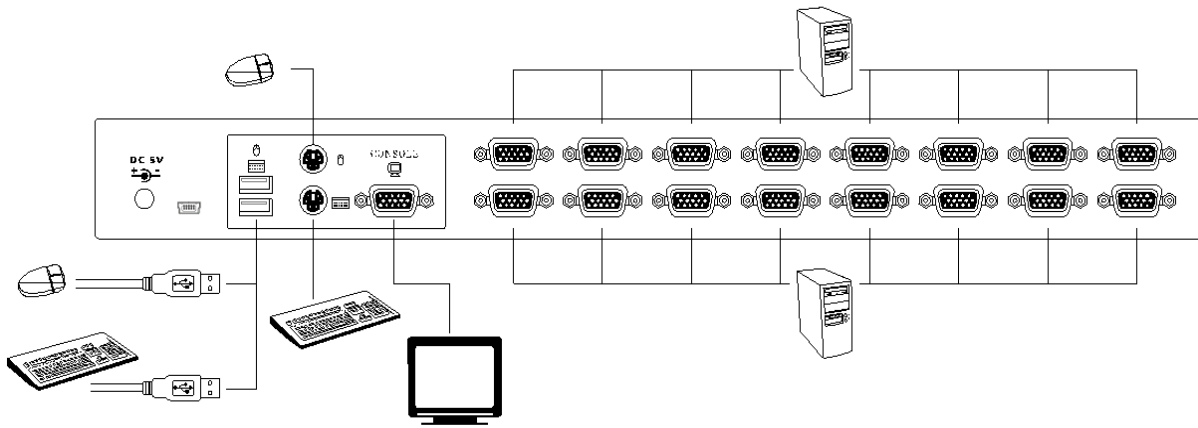

Figure 5: Console connection

4.3.3. System Connection

You need a custom combo cable to connect a computer to the EZswitch KVM switch.

Note: If needed, contact your dealer or Raritan to purchase the custom KVM cables.



Figure 6: Custom KVM cable

There are three different ways to connect a computer. See the instructions below:

- A. Plug the combo cable's USB, PS/2 keyboard, PS/2 mouse and VGA connectors into a computer (see *Figure 7*). This method is highly recommended for computer connection.

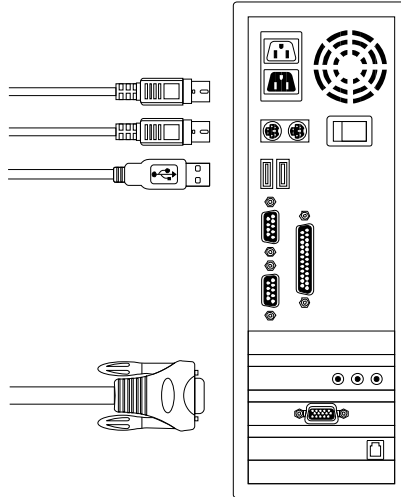

Figure 7: USB, PS/2 and VGA connections

- B. Plug only the combo cable's PS/2 keyboard, PS/2 mouse and VGA connectors into a computer (see *Figure 8*).

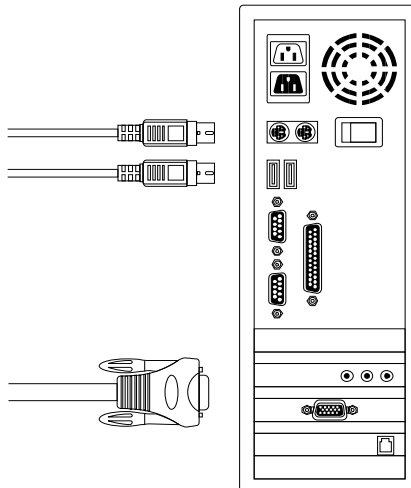

Figure 8: PS/2 and VGA connections

- C. Plug only the combo cable's USB and VGA connectors into a computer (see *Figure 9*).

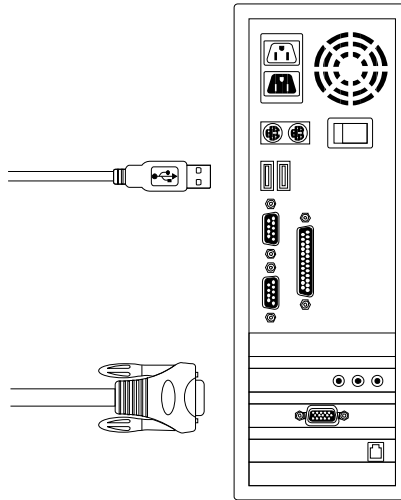

Figure 9: USB and VGA connections

4.4. Cascade KVM Switches (Multi-Tier Installation)

You can cascade either the 8-port or the 16-port EZswitch products up to 3 tiers, expanding the number of computers to 64, 256 or 4096 computers. No special configuration is required for the cascade.

After completing the installation, the system automatically configures the Master and Slave KVM switches. The Master KVM switch is the first-tier KVM switch and Slave KVM switches are second-tier or third-tier KVM switches. You can select the computers connected to the Master or Slave KVM switches at any time.

To cascade KVM switches, follow these instructions:

- A. Turn OFF all computers and devices.
- B. Connect one or more Slave KVM switches to the channel ports on the Master KVM switch using the custom combo cables (see *Figure 6*). **The connection between KVM switches must be done via the PS/2 interface (see *Figure 7* & *Figure 8*).**
- C. Connect a USB or PS/2 keyboard and mouse to the console ports on the Master KVM switch.
- D. Connect a power adaptor to the Master KVM switch.
- E. Connect computers to available channel ports on the Master KVM switch.
- F. Connect a power adaptor to each Slave KVM switch.
- G. Connect computers to available channel ports on the Slave KVM switch.
- H. Turn on each device in the following sequence:
 1. Master KVM switch

2. Second-tier Slave KVM switches (connected to the Master KVM switch), if any
 3. Third-tier Slave KVM switches (connected to the second-tier Slave KVM switches), if any
 4. All computers connected to KVM switches
- I. Connect other devices such as a monitor or new computers to the Master KVM switch before turning on the additional devices.
 - J. Now you can hot swap or hot plug any devices into any KVM switches. Both of 8-port and 16-port KVM switches support hot plug and hot swap functions.

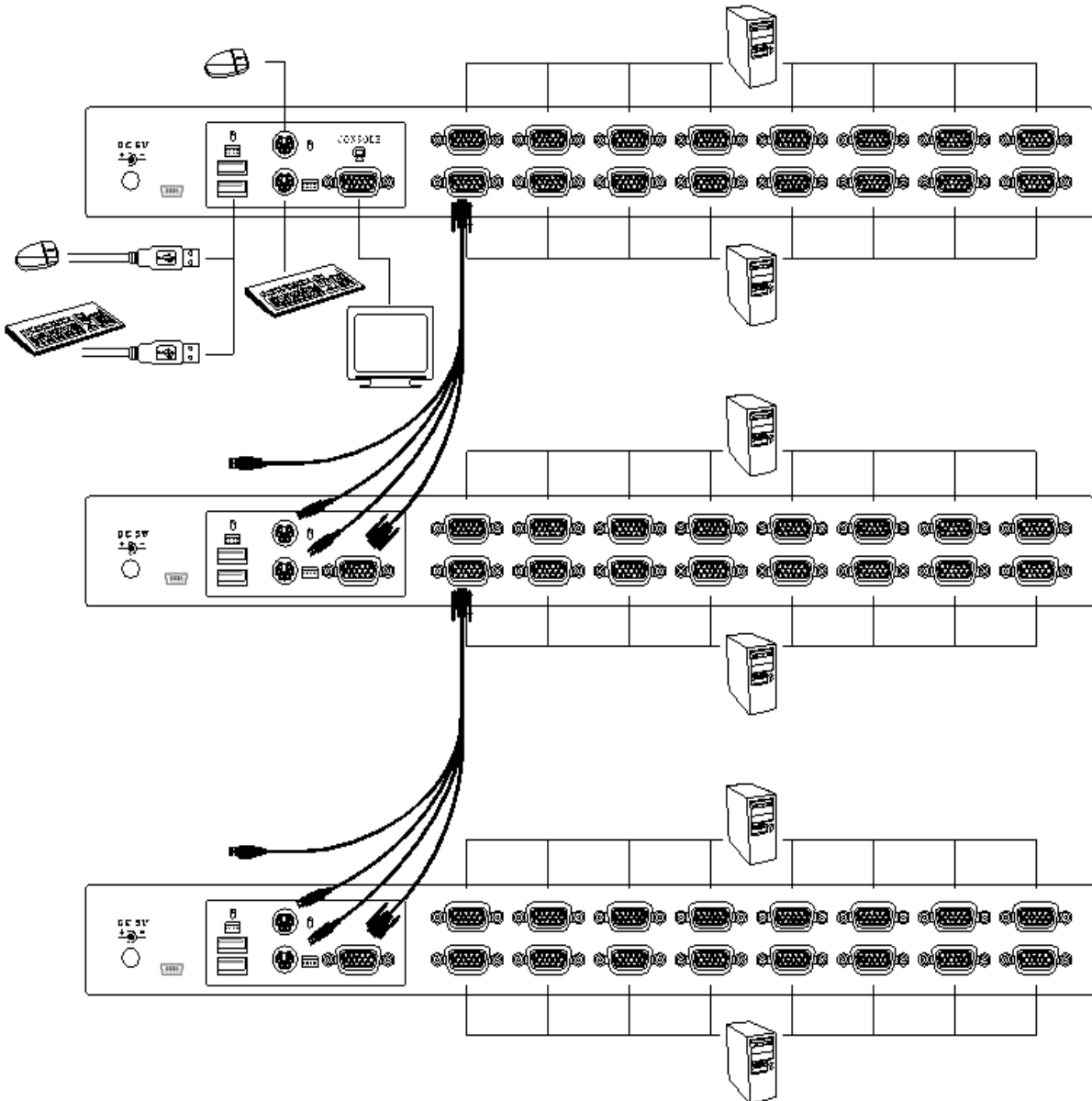

Figure 10: Cascaded configuration

4.5. Firmware Upgrade Port

The min-USB female connector on the rear of the EZswitch KVM switch is used for firmware upgrade. Contact your dealer or Raritan when you need to update the firmware.

4.6. Rack-Mount the KVM Switch

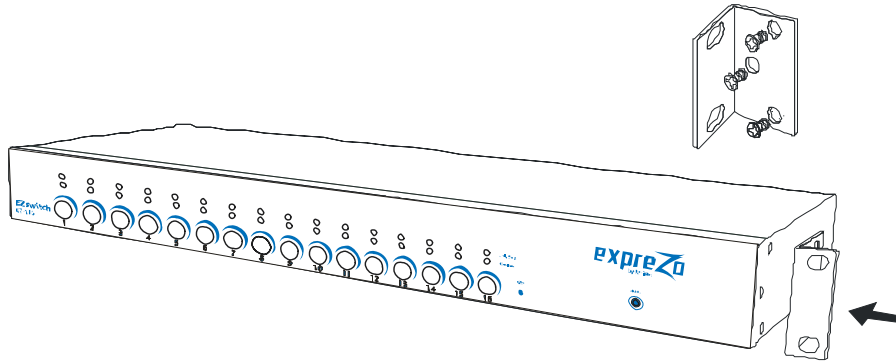

Figure 11: Rack mounting

This section describes how to attach mounting brackets to the KVM switch for rack-mounting it on a standard 19-inch rack.

- A. Screw the mounting brackets to the sides of the KVM switch (see *Figure 11*).
- B. Mount the KVM switch on a rack.

5. Operation

You can control computers connected to the EZswitch KVM switch by using the push buttons, hot keys or OSD interface.

- **Push button operation:**
Press a front panel push button to select the corresponding computer and operate it.
- **Hot Key operation:**
See the section “6. Hot Key Operation.”
- **OSD operation:**
See the section “7. OSD Operation.”

6. Hot Key Operation

6.1. Trigger the OSD Menu

Press **<Scroll Lock>** twice and then press **<Enter>**. The OSD main menu will be displayed on the screen. All of the KVM settings can be configured through the OSD interface. Some KVM functions can also be performed using the OSD.

<Scroll Lock> + <Scroll Lock> + <Enter>

6.2. Set the Leading Hot Key

A hot key allows you to quickly perform a specific function.

Its leading key is set to **<Scroll Lock>** by default. You can change this key if needed.

To change the leading hot key, follow this procedure:

Press **<CTRL>** twice, then the new leading hot key, and finally press **<Enter>**. The leading hot key is changed then.

Available leading hot key options include **<Scroll Lock>**, **<Num Lock>** and **<Caps Lock>**.

Examples:

- To set the leading hot key to **<Scroll Lock>**:
<CTRL> + <CTRL> + <Scroll Lock> + <Enter>
- To set the leading hot key to **<Num Lock>**:
<CTRL> + <CTRL> + <Num Lock> + <Enter>
- To set the leading hot key to **<Caps Lock>**:
<CTRL> + <CTRL> + <Caps Lock> + <Enter>

*Tip: You can also change the leading hot key by pressing **<F1>** in the OSD main menu. See the section “7.3.5 Hot Key.”*

6.3. Channel Selection in a Single-Tier KVM System

6.3.1. Select a Specific Channel

You can select a connected computer by using the hot key combination: first press **<Scroll Lock>** twice, then a number (1~16) corresponding to the channel number of the computer that you want to control, and finally press **<Enter>**.



Figure 12: Channel selection hot key

Examples:

- <Scroll Lock> + <Scroll Lock> + <1> + <Enter>
- <Scroll Lock> + <Scroll Lock> + <2> + <Enter>
- ⋮
- <Scroll Lock> + <Scroll Lock> + <16> + <Enter>

Tip: You can also select a computer in the OSD menu. See the section “7.2 Channel Selection Using the OSD.”

6.3.2. Channel Switching Using Arrow Keys

To switch to the prior or next channel that is adjacent to the current channel, do this: first press **<Scroll Lock>** twice, and then the **<Left arrow>** or **<Right arrow>** key.

- **To switch to the prior channel:**
<Scroll Lock> + <Scroll Lock> + <Left arrow>
- **To switch to the next channel:**
<Scroll Lock> + <Scroll Lock> + <Right arrow>

6.3.3. Channel Switching Using the <ALT> Key

You can also switch to the prior or next channel using the **<ALT>** key combinations.

A. Enable the <ALT> channel switching function:

By default, the channel switching function using the **<ALT>** key is disabled. To enable it, press **<Scroll Lock>** twice, then **<ALT>** and finally **<Enter>**. To disable the function, press the same key combinations again.

B. Switch to the prior or next channel using the <ALT> key:

Press the <Left ALT> or <Right ALT> key twice, and the system will automatically switch to the prior or next channel.

- **Enable/disable the <ALT> channel switching function:**
<Scroll Lock> + <Scroll Lock> + <ALT> + <Enter>
- **Switch to the prior channel:**
<Left ALT> + <Left ALT>
- **Switch to the next channel:**
<Right ALT> + <Right ALT>

6.4. Channel Selection in a Multi-Tier KVM System

A cascaded KVM system allows you to select a channel at any tier directly. Use the following hot key combination to select a channel:

Press <Scroll Lock> twice, the <D> key, then the number of the channel (1~16) where the computer or the second or third tier is connected, and finally press <Enter>.

- **Select a channel at the first tier:**
<Scroll Lock> + <Scroll Lock> + <D> + <1st tier channel number> + <Enter>
- **Select a channel at the second tier:**
<Scroll Lock> + <Scroll Lock> + <D> + <1st tier channel number>
+ <D> + <2nd tier channel number> + <Enter>
- **Select a channel at the third tier:**
<Scroll Lock> + <Scroll Lock> + <D> + <1st tier channel number>
+ <D> + <2nd tier channel number>
+ <D> + <3rd tier channel number> + <Enter>

For example, to select channel 7 at the last tier in a 3-tier configuration, you may press <Scroll Lock> twice, then **D2D5D7**, and finally <Enter>.

D2 means channel 2 of the first tier.

D5 means channel 5 of the second tier.

D7 means channel 7 of the third tier.

Tip: You can also select a channel of a multi-tier KVM system using the OSD menu. See the section “7.2.2 Select a Second- or Third-Tier Channel.”

6.5. Disable or Enable the Buzzer

To disable or enable the buzzer function, press **<Scroll Lock>** twice, then **** and **<Enter>**. The buzzer is enabled by default.

<Scroll Lock> + <Scroll Lock> + + <Enter>

Tip: You can also enable/disable the buzzer by pressing <F1> in the OSD main menu. See the section “7.3.6 Sound.”



Figure 13: Hot key for buzzer

6.6. Auto-Scan Function

After enabling the Auto-Scan function, the KVM switch will cycle through all channels and display them one by one on the screen. At this time, both of the mouse and keyboard are disabled to prevent any accidental operation errors, such as erratic movement of the mouse or wrong inputs.

6.6.1. Enable the Auto-Scan Function

To activate the Auto-Scan function, press **<Scroll Lock>** twice, then **<S>** and **<Enter>**.

<Scroll Lock> + <Scroll Lock> + <S> + <Enter>

A banner will be shown on the screen to indicate the currently-scanned channel.

Tip: You can also enable the Auto-Scan function in the OSD main menu. See the section “7.4 Auto-Scan Using the OSD.”



Figure 14: Auto-Scan hot key

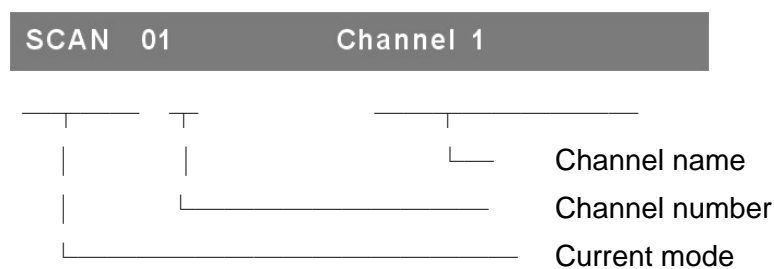

Figure 15: Auto-Scan banner

6.6.2. Disable the Auto-Scan Function

To quit the Auto-Scan mode, press any key on the keyboard. You can also quit the mode by pressing a push button on the KVM front panel to select the corresponding channel.

6.6.3. Different Auto-Scan Modes

There are two types of Auto-Scan modes:

- Scan all computers that are powered on.
- Scan only those computers which have been marked to be scanned.

See the section “7.3.1 Scan Mode” to set the Auto-Scan mode.

6.6.4. Auto-Scan Time Interval

The Auto-Scan time interval can be adjusted by pressing **<F1>** in the OSD main menu. See the section “7.3.2 Scan Time.”

6.7. Console Lock

If the security mode has been enabled (by pressing **<F5>** in the OSD mode), you can lock the console by pressing **<Scroll Lock>** twice, then **<H>** and **<Enter>**. The KVM switch will be locked until a user logs in successfully.

<Scroll Lock> + <Scroll Lock> + <H> + <Enter>

To unlock the console, follow the onscreen messages to press any key, and type the User Name and Password. After the successful login, the KVM switch and console devices are unlocked and you can resume normal operation.

Tip: You can also lock the console in the OSD main menu. See the section “7.5 Console Lock Using the OSD.”

7. OSD Operation

7.1. OSD Main Menu

To trigger the OSD main menu, press **<Scroll Lock>** twice and **<Enter>**. The OSD main menu shows all channel numbers, names and status. See *Figure 16*.

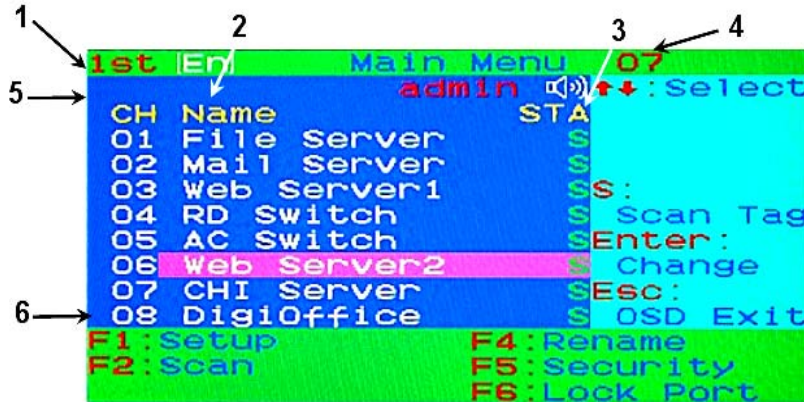

Figure 16: OSD main menu

7.1.1. Tier Number

1st, 2nd or 3rd, which is displayed in the upper-left corner of the OSD main menu indicates the current tier.

7.1.2. Channel Name

The channel name can be changed by pressing the function key **<F4>**. You can give the channel a meaningful name for easily identifying the connected

computer.

A highlight bar in pink shows which channel is being selected.

A plus mark (+) to the left of the channel name means the channel port is connected to a second- or third-tier KVM switch.

7.1.3. Computer & KVM Switch Status

➤ **Buzzer status of the KVM switch**

🔊 : Buzzer is turned on.

🔇 : Buzzer is tuned off.

➤ **Logged-in user name**

The system provides one administrator and 3 user names for security management. The current login name (if available) is displayed next to the buzzer status.

➤ **Channel lock status (Status STA)**

L: The presence of the L letter indicates that channel is locked.

BLANK: The absence of the L letter indicates that channel is NOT locked.

➤ **Computer power-on status (Status STA)**

The OSD menu will update the flag automatically if the computer status is changed.

A: The presence of the A letter indicates the connected computer is powered on and can be selected.

BLANK: The absence of the A letter indicates a computer is NOT connected or NOT powered on.

➤ **Channel scan tag (Status STA)**

S: The presence of the S letter indicates the channel is included as one of the channels to be scanned in the Auto-Scan mode. Note that the channel will be scanned only when the scan mode is set to the **Select** type.

BLANK: The absence of the S letter indicates the channel is NOT marked for Auto-Scan

7.1.4. Currently Selected Channel Number

The number shown in the upper-right corner of the OSD main menu indicates the currently selected channel number.

If the selected channel is on the 2nd or 3rd tier, the channel number looks like XX-YY-ZZ. For example, 02-05-07 means the selected channel is channel 7 of the third tier, which is connected to the channel 5 of the second tier, which is

connected to the channel 2 of the first tier.

7.1.5. Parent Channel Number

The number below the tier number is the channel number of the upper tier, where the tiered KVM switch is connected. For example, 8 means channel 8 of the upper-tier KVM switch.

This number is available for the 2nd- and 3rd-tier channels, but unavailable for the 1st tier.

7.1.6. Page Down / Up Indicator

This indicator is available for the 16-port KVM switch only. The 16-port KVM switch displays 16 channels in two pages: the first page shows the first eight channels, and the second page shows the last eight channels. Therefore, the **Page Down / Up indicator** appears to remind users to go to the other page by pressing the **<Page Down>** and **<Page Up>** key.

7.1.7. Function Keys Menu

The following lists the function keys that can be used for operation:

<F1>: Trigger the setup menu

<F2>: Enable the Auto-Scan function

<F3>: Set up the lock and unlock function (available only when the security function is enabled)

<F4>: Rename the selected channel

<F5>: Set up the security function and user authorization settings

<F6>: Lock the channel (available for the administrator only)

More information regarding these function keys is described in later sections.

7.2. Channel Selection Using the OSD

7.2.1. Select a Channel

Use the **<UP arrow>** and **<DOWN arrow>** keys to highlight a channel and then press **<Enter>**. A bar showing the channel name appears in the upper-left corner of the screen.

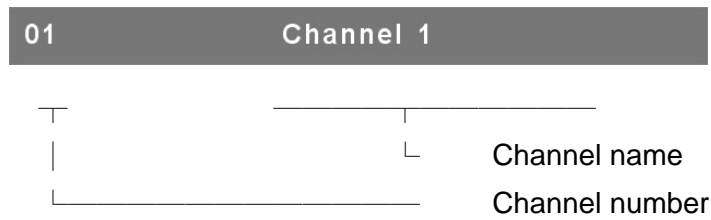

Figure 17: Channel banner (single tier)

7.2.2. Select a Second- or Third-Tier Channel

A plus mark (+) to the left of the channel name indicates a tiered KVM switch is connected to this channel port. Pressing **<Enter>** lets you enter the next tier, and the screen displays a list of channels of the selected Slave KVM switch.

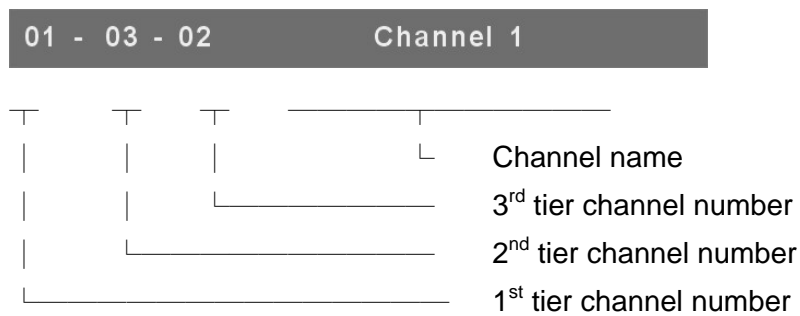

Figure 18: Channel banner (multi tier)

7.2.3. Return to the Upper-Tier OSD

To return to the OSD menu of the upper tier, press **<R>**.

7.3. Setup Menu

In the Setup menu, you can use these keys:

- To select the field whose settings you want to change, press the **<Up arrow>** or **<Down arrow>** key.
- To change the settings, press the **<Left arrow>** or **<Right arrow>** key.
- To save the changes and exit, press **<ESC>**.



Figure 19: OSD Setup menu

7.3.1. Scan Mode

➤ **Select:**

With this option selected, only the channels that are marked with **S** in the **STA** column in the OSD main menu will be scanned after entering the Auto-Scan mode.

➤ **PC ON:**

This option will scan all channels where computers are connected and powered on.

7.3.2. Scan Time

The default scan time interval is 5 seconds. The value is an integer multiple of 5 between 5 and 255.

7.3.3. Banner Time

By default, a channel banner is displayed on the screen for 5 seconds. The options include 5, 10 and 15 seconds and All. Selecting “All” causes the banner to be displayed all the time.

7.3.4. Position

➤ **Menu:**

Press the arrow keys to move the OSD main menu until it reaches the desired position. Then press **<ESC>** to save the new position.

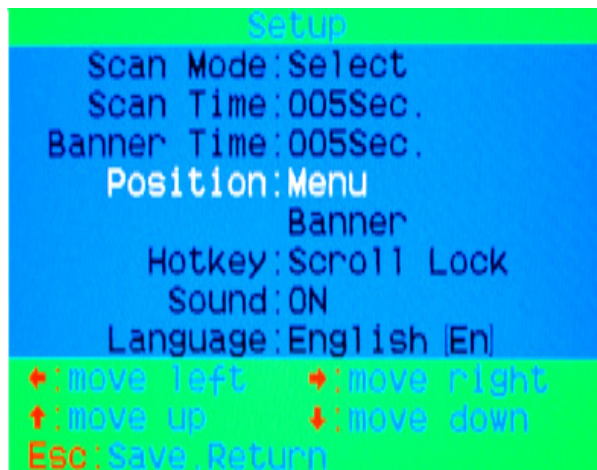

Figure 20: Menu position setup

➤ **Banner:**

Press the arrow keys to move the channel banner until it reaches the desired position. Then press **<ESC>** to save the new position.



Figure 21: Channel banner position setup

7.3.5. Hot Key

The default hot key is **<Scroll Lock>**. You can change the hot key and set it to **<Num Lock>** or **<Caps Lock>** if necessary.

*Tip: To change the leading hot key, you must use the hot key combination: **<CTRL>** + **<CTRL>** + **<New leading hot key>** + **<Enter>**, when **NOT** in the OSD mode. See the section “6.2 Set the Leading Hot Key.”*

7.3.6. Sound

- **ON:** Buzzer is enabled.
- **OFF:** Buzzer is disabled.

*Tip: You can also enable/disable the buzzer by using the hot key combination: **<Scroll Lock>** + **<Scroll Lock>** + **** + **<Enter>**, when **NOT** in the OSD mode. See the section “6.5 Disable or Enable the Buzzer.”*

7.3.7. Language

3 languages are available for showing the OSD menus, including English (En), Deutsch (De), and Francais (F).

7.4. Auto-Scan Using the OSD

7.4.1. Enable the Auto-Scan Function

To activate the Auto-Scan function in the OSD mode, press **<F2>**. The Auto-Scan banner is displayed to indicate the currently-scanned channel.

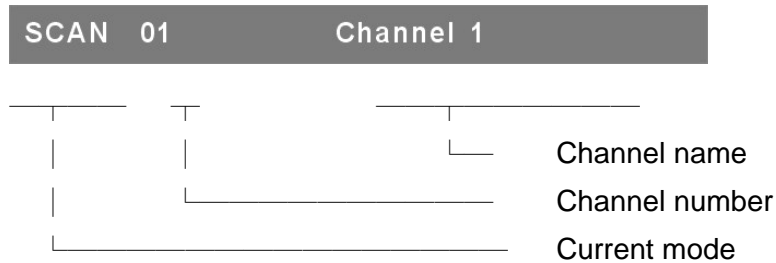

Figure 22: Auto-Scan banner

Tip: You can also activate the Auto-Scan function by using the hot key combination: <Scroll Lock> + <Scroll Lock> + <S> + <Enter>, when NOT in the OSD mode. See the section “6.6.1 Enable the Auto-Scan Function.”

7.4.2. Disable the Auto-Scan Function

To quit the Auto-Scan mode, press any key on the keyboard. The Auto-Scan banner disappears when the Auto Scan stops.

7.4.3. Different Auto-Scan Modes

There are two types of Auto-Scan modes:

- Scan all computers that are powered on.
- Scan only those computers which have been marked to be scanned.

See the section “7.3.1 Scan Mode” to set the Auto-Scan mode.

7.4.4. Auto-Scan Time Interval

The Auto-Scan time interval can be adjusted by pressing **<F1>** in the OSD main menu. See the section “7.3.2 Scan Time.”

7.5. Console Lock Using the OSD

If the security mode has been enabled (see the section “7.7 Security Setup”), you can lock the console by pressing **<F3>** in the OSD mode to log out of the system. The Console Lock banner is displayed on the screen.



Figure 23: Console Lock banner

The KVM switch will be locked until a user logs in successfully.



Figure 24: Login banner

*Tip: You can also logout to lock console by using the hot key combination: **<Scroll Lock>** + **<Scroll Lock>** + **<H>** + **<Enter>**, when NOT in the OSD mode. See the section “6.7 Console Lock.”*

If you forget your password, the only way to disable the security function is to type a universal password to unlock the KVM switch. Contact your dealer or Raritan Technical Support for the universal password.

7.6. Rename a Channel

Select the channel that you want to rename by pressing the Up/Down arrow keys and then **<F4>** in the OSD main menu. The Rename dialog appears for you to change the channel name. Press **<Enter>** to save the new channel name or **<ESC>** to cancel.



Figure 25: Rename dialog

7.7. Security Setup

7.7.1. Security Mode Login

Press **<F5>** in the OSD main menu to enter the security setup mode. The administrator login is required for entering the security mode.



Figure 26: Security mode login prompt

The default administrator account is:

User Name: admin
Password: 123456

Press **<Enter>** after typing the admin user name and password respectively.

The security setup menu is shown on the screen after successful login. Press the **<Up arrow>** and **<Down arrow>** keys to select the security field, and then press the **<Left arrow>** and **<Right arrow>** keys to change the settings.

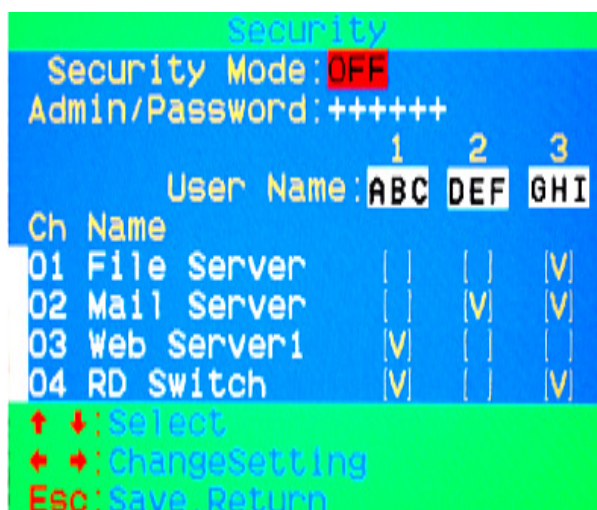

Figure 27: Security setup menu

7.7.2. Security Mode

To change the security mode settings, move the highlight bar to the **Security Mode** field, and press the **<Left arrow>** or **<Right arrow>** key to change the option.

The following functions cannot be performed without enabling the security mode:

- **Console Lock: <F3>**
- **Port Lock: <F6>**
- **User authorization settings**

7.7.3. Change the Administrator Password

To change the administrator password, move the highlight bar to the **Admin/Password** field, and press the **<Left arrow>** or **<Right arrow>** key. The admin password setup dialog is shown on the screen. Type the new password in the **New Password** field, and then press **<Enter>** to accept it or **<ESC>** to quit. Type the same password again in the **Confirm Password** field, and press **<Enter>** to accept it or **<ESC>** to quit.



Figure 28: Administrator password setup dialog

7.7.4. User Account Settings

3 built-in user accounts are permitted to access and administer the KVM switch: ABC, DEF, and GHI.

To change the user name and set the password, move the highlight bar to one of the user names. Then press the **<Left arrow>** or **<Right arrow>** key. The user account setup dialog is shown on the screen. Type the new user name and press **<Enter>** to accept it or **<ESC>** to cancel. Type the password for the user account in the **New Password** field and type the same password again in the **Confirm Password** field.



Figure 29: User account setup dialog

7.7.5. User Authorization Settings

You can set up the permissions for each user account. Different users may have different access permissions for each channel. To change the access

permissions of a specific user, move the highlight bar to the channel, and press <A>, <1>, <2> or <3> to set the channel access permissions for all or specific user accounts.

Note: It is not necessary to set the permissions for the administrator since the administrator has full access permissions.



Figure 30: User access permission setup

7.8. Port Lock

7.8.1. Lock a Channel Port

Only the administrator can lock a channel port. Move the highlight bar to a channel, and press <F6> to lock it. Then a red L letter is displayed in the STA column to indicate the channel is being locked.



Figure 31: Lock port in the OSD main menu

7.8.2. Select a Locked Channel

If anyone selects the channel that has been locked by pressing either the front panel push button or a hot key combination, the OSD main menu appears. Press **<ESC>** after the OSD main menu appears, and then type the admin user name and password to unlock the channel port when prompted.

7.8.3. Unlock a Channel Port

Only the administrator's user name and password can unlock a channel port. After entering the admin user name and password, the red **L** letter shown in the **STA** column disappears, and you can select the channel.

7.9. Exit OSD

Pressing **<ESC>** lets you exit from the OSD interface and return to the selected channel. A banner with the channel name is shown in the upper-left corner of the screen.

8. Special Sun Key Emulation

A Sun keyboard has 16 special function keys. EZswitch can emulate these function keys with a PS/2 or USB keyboard. See the table below for how to emulate these Sun keys.

To activate the emulation function on a PS/2 and USB keyboard:

- A. Press and hold down the **<Left Windows>** key, which is usually located between the **<Left CTRL>** and **<Left ALT>** key.
- B. Press the second key listed in the following table. Do not release the **<Left Windows>** key while pressing the second key.

Sun key	Press these keys...
Stop	<Left Windows> + <Left ALT>
Props	<Left Windows> + <Left CTRL>
Compose	<Left Windows> + <Left Shift>
Front	<Left Windows> + <F1>
Open	<Left Windows> + <F2>
Find	<Left Windows> + <F3>
Again	<Left Windows> + <F4>
Undo	<Left Windows> + <F5>
Copy	<Left Windows> + <F6>
Paste	<Left Windows> + <F7>
Cut	<Left Windows> + <F8>
Help	<Left Windows> + <F11>
Power	<Left Windows> + <F12>
Mute	<Left Windows> + <1>
Volume Down	<Left Windows> + <2>
Volume UP	<Left Windows> + <3>

9. Troubleshooting

Symptom	Possible cause	Recommended solution
Keyboard and/or mouse not functional	Keyboard and/or mouse require a reset	Unplug and replug the keyboard and/or mouse.
	Loose cable connection to the computer	Verify the cable is securely connected to the KVM switch and to the computer.
	The KVM switch requires a reset	Power cycle all devices.
Master/Slave daisy chaining does not work	Inappropriate configuration or incorrect installation procedure	<ul style="list-style-type: none"> ● Verify the Slave's console is connected to the Master's PC port. ● Remove the power supply to the slave (that is, unplug the power adaptor) before connecting it to the Master.
Two OSD images appear in the multi-tier configuration	Incorrect installation procedure or loose cable connections	<ul style="list-style-type: none"> ● Remove the power supply to the slave (that is, unplug the power adaptor) before connecting it to the Master. ● Verify the Slave's console is securely connected to the Master's PC port.
Inappropriate OSD menu position	The OSD menu's resolution is fixed and its onscreen dimension varies depending on the computer's VGA resolution that applies	In the OSD main menu, press <F1> to change the menu and/or banner's position.

10. Firmware Upgrade

You can update any of the following on a KVM switch through a firmware upgrade:

- **USB Console:** Update the USB keyboard/mouse compatibility.
The firmware filename for the USB console is similar to **OTG_182S_SCAN_Vx.xx.300**.
- **PS/2 Console:** Update the PS/2 keyboard/mouse compatibility.
The firmware filename for the PS/2 console is similar to **CONSOLE_Vx.xx.28**.
- **OSD:** Update the OSD functions.
The firmware filename for updating the OSD is similar to **OSD_Vx.xx.56**.

Follow this procedure to update the firmware:

- A. Disconnect all cables connected from the KVM switch to computers.
- B. Disconnect both of the keyboard and mouse connected to the KVM switch.
- C. Disconnect the VGA cable connected from the KVM switch to the monitor.
- D. Connect the 5V power adaptor to the KVM switch.



Figure 32: 5V power adaptor

- E. Perform the firmware update utility “ExpreZo KVM Upgrade Utility v.1.0.EXE.”

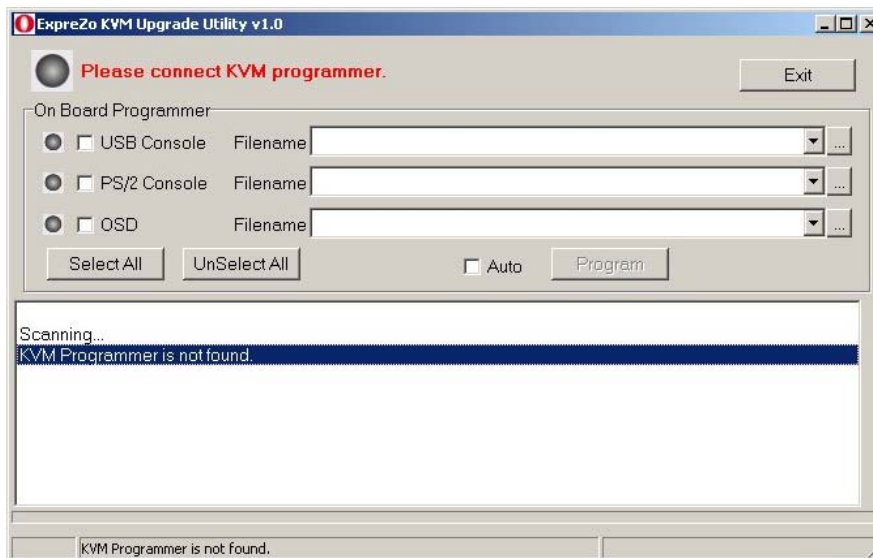

Figure 33: KVM upgrade utility window

- F. Connect the mini-USB cable from the KVM switch's firmware update port to the USB port on a computer running the firmware update utility.



Figure 34: Mini-USB cable

- G. The utility automatically detects the KVM switch's programmer.

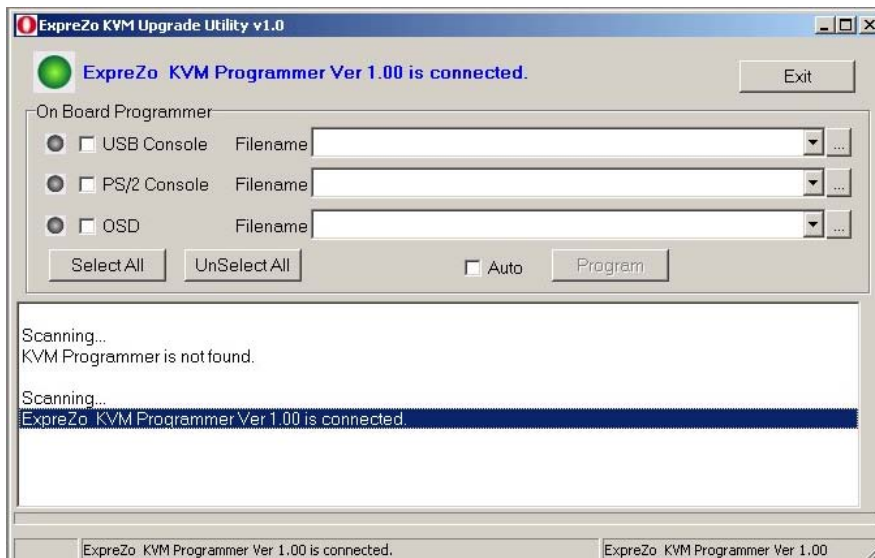

Figure 35: KVM programmer detected message

- H. Select the item that you want to update by enabling the corresponding checkbox(es). For example, select the “USB Console” checkbox and click the Browse (...) button to select the firmware file.

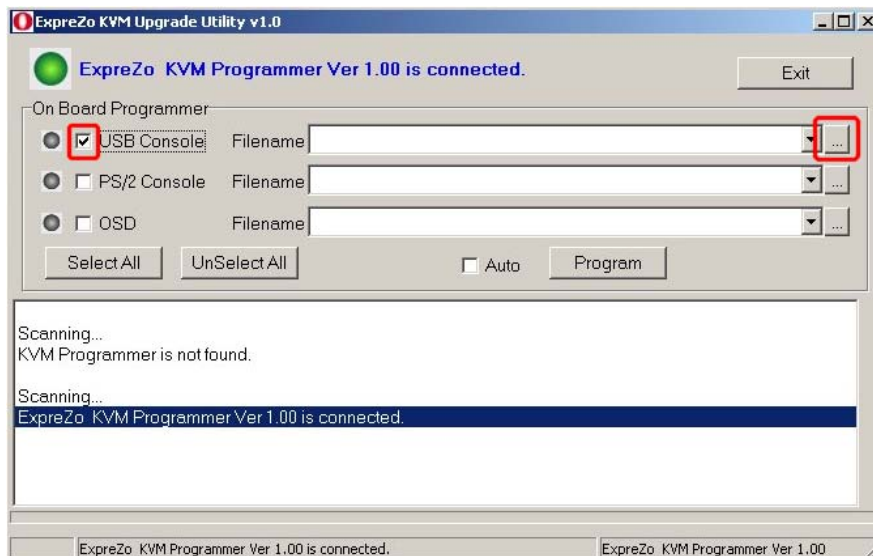

Figure 36: USB Console checkbox selected

- I. In the Open dialog, select the appropriate firmware file and click Open.

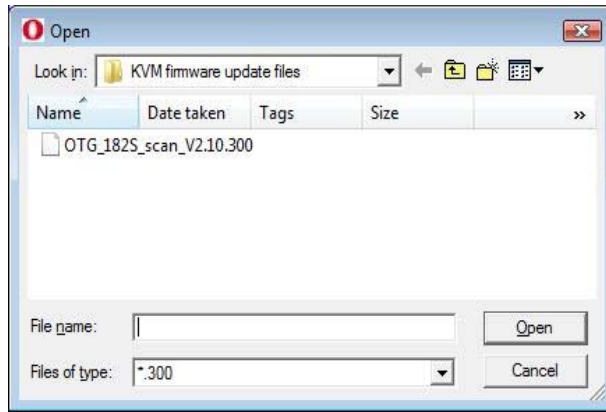

Figure 37: Open dialog

- J. Click the “Program” button to start the firmware update.

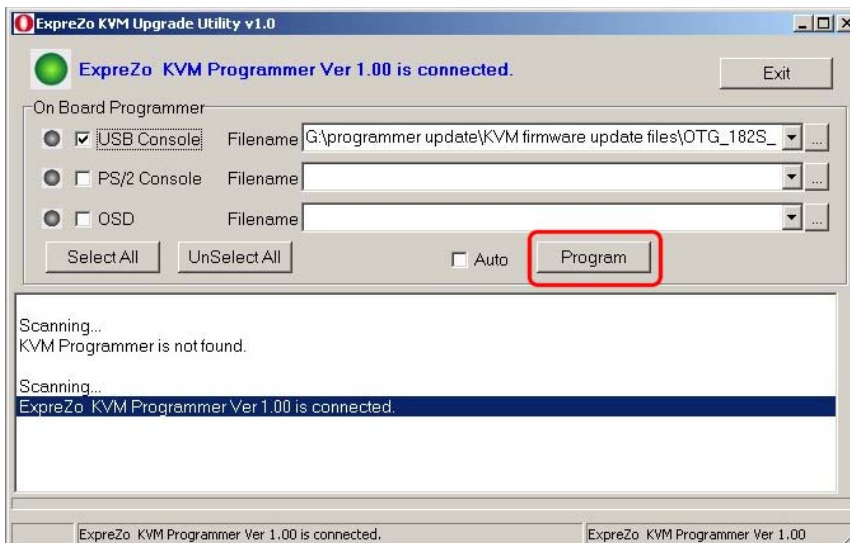

Figure 38: Program button

- K. A status bar is displayed at the bottom of the dialog to indicate the update progress.

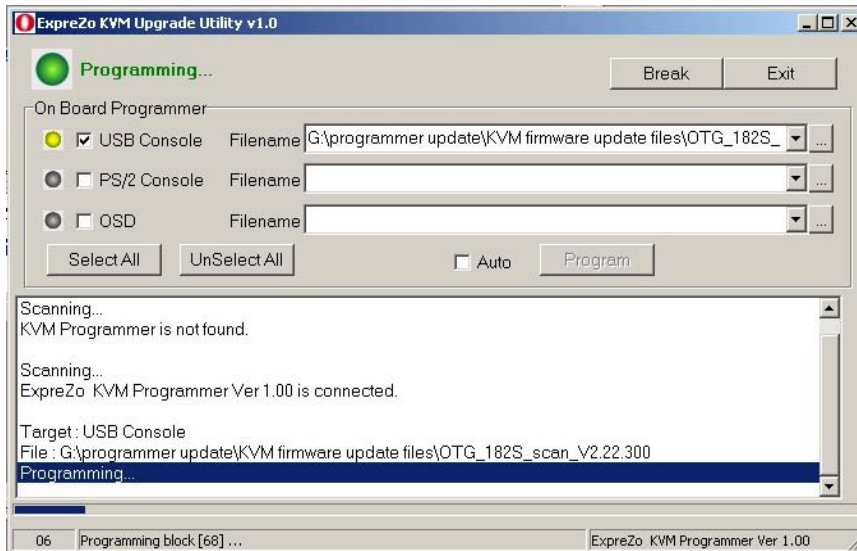

Figure 39: Update progress bar

L. The firmware is updated successfully.

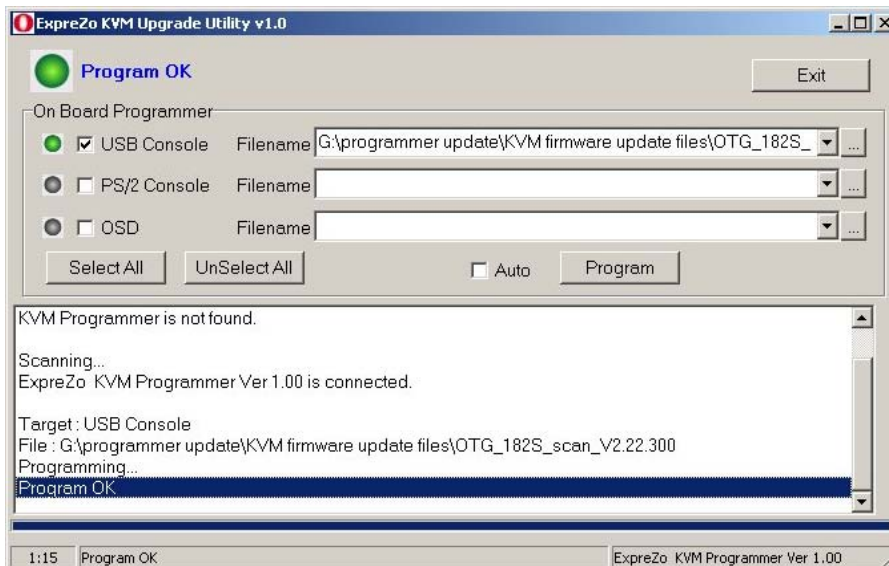

Figure 40: The successful update message

11. Tiering with Dominion KX II

Dominion KX II is an enterprise-class, secure, digital KVM switch that provides access and control of servers from anywhere in the world via a web browser. With Dominion KX II, you can have the EZswitch system remotely accessed over a TCP/IP network through the use of a web browser.

11.1. Connect EZswitch to Dominion KX II

- A. Connect a Dominion Computer Interface Module (CIM) to the video and PS/2 or USB ports on the rear panel of the EZswitch KVM switch.

Note: You can use any Dominion CIM except for DCIM-VUSB.

- B. Connect one end of a UTP (Cat5/5e/6) cable to the CIM and the other end of the cable to one of available server ports on the Dominion KX II KVM switch.

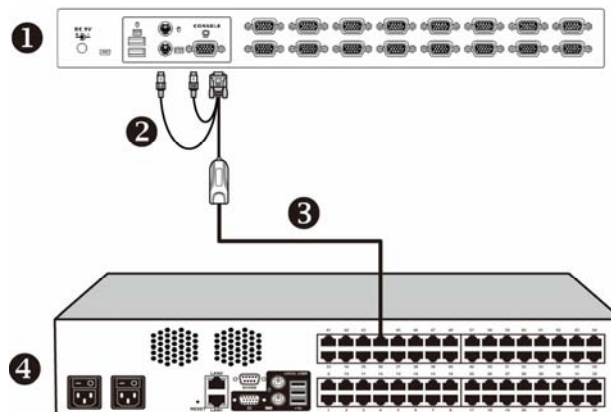

Figure 41: Integration of EZswitch and Dominion KX II

1	EZswitch
2	Dominion CIM
3	UTP (Cat5/5e/6) cable
4	Dominion KX II

11.2. Configure Dominion KX II

You must configure Dominion KX II for use of hot key sequences to switch between channels of the EZswitch KVM switch.

- A. Log in to the Dominion KX II.
For instructions, see the Dominion KX II User Guide, which can be downloaded from Raritan's website (www.raritan.com).
- B. Choose Device Settings > Port Configuration. The Port Configuration page opens.

- C. Click the name of the port where the EZswitch KVM switch is connected. The Port page opens.
- D. Select KVM Switch.

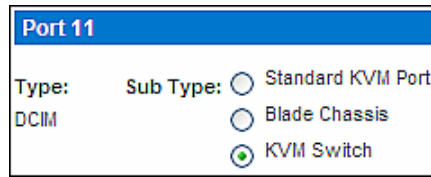

Figure 42: KVM Switch radio button selected

- E. Ensure “Generic Analog KVM Switch” is selected in the KVM Switch Model field.
- F. In the KVM Switch Hot Key Sequence field, select the hot key applied to the EZswitch KVM switch for channel selection. EZswitch’s default hot key is “ScroLLock + ScroLLock + SlotNumber.”

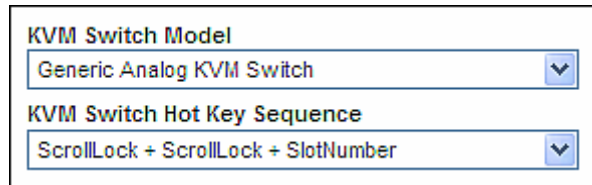

Figure 43: KVM Switch Model and KVM Switch Hot Key Sequence fields

- G. In the Maximum Number of Target Ports (2-32) field, enter the number of your EZswitch device’s channels. Type 8 for an 8-port EZswitch KVM switch or 16 for a 16-port EZswitch KVM switch.
- H. In the KVM Switch Name field, enter the name you want to use to refer to this port connection.
- I. Activate the channel ports (targets) that the KVM switch hot key sequence will be applied to by selecting ‘Active’ for each of the ports.



Active	Target 1	Active	Target 2
<input checked="" type="checkbox"/>	EZswitch_Target1	<input checked="" type="checkbox"/>	EZswitch_Target2
	Target 3		Target 4
<input checked="" type="checkbox"/>	EZswitch_Target3	<input checked="" type="checkbox"/>	EZswitch_Target4
	Target 5		Target 6
<input checked="" type="checkbox"/>	EZswitch_Target5	<input checked="" type="checkbox"/>	EZswitch_Target6
	Target 7		Target 8
<input checked="" type="checkbox"/>	EZswitch_Target7	<input checked="" type="checkbox"/>	EZswitch_Target8

Figure 44: Activation of each port

- J. Click OK.

11.3. Remote Access to an EZswitch Channel

After properly configuring Dominion KX II, you can remotely access any computer connected to the EZswitch KVM switch via Dominion KX II.

- A. Launch the web browser, and type the IP address for Dominion KX II.
- B. The login page opens. Type a valid user name and password, and click Login.

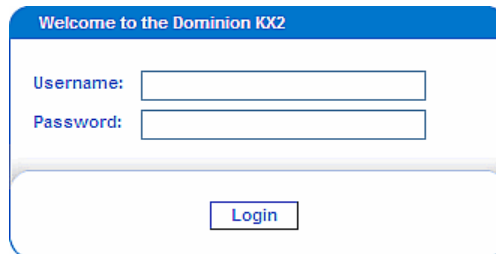

Figure 45: Login page

- C. The Port Access page opens. If not, click the Port Access tab.
- D. Click the name of the port where EZswitch is connected. All channels (targets) of the EZswitch KVM switch are displayed.

11	▼ EZswitch_Port11	KVMSwitch
11-1	EZswitch_Target1	Cascaded
11-2	EZswitch_Target2	Cascaded
11-3	EZswitch_Target3	Cascaded
11-4	EZswitch_Target4	Cascaded
11-5	EZswitch_Target5	Cascaded
11-6	EZswitch_Target6	Cascaded
11-7	EZswitch_Target7	Cascaded
11-8	EZswitch_Target8	Cascaded

Figure 46: Channel ports of EZswitch

- E. Click the desired channel.
- F. Click Connect. A Virtual KVM Client window opens to the selected EZswitch channel.

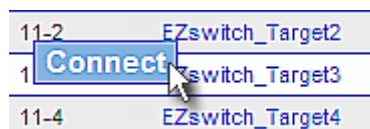

Figure 47: Connection to an EZswitch channel

For detailed information on Dominion KX II, see the Dominion KX II User Guide, which can be downloaded from the Firmware and Documentation section of Raritan's website (<http://www.raritan.com/support/firmware-and-documentation/>).

12. Keyboard and Mouse Compatibility

A number of USB and PS/2 keyboards and mice are compatible with the EZswitch KVM switch. Note that it is likely that the USB or PS/2 keyboards and mice other than those listed in the tables may be also compatible with the product.

12.1. Mouse Compatibility Table

Manufacture	Model	Type	Remark
A4-TECH	NB-50	USB	Wireless
A4-TECH	SWOP-53	USB	
A4-TECH	SWOP-54	PS/2	
A4-TECH	BW-35	USB	
A4-TECH	SWW-35	PS/2	
A4-TECH	WWW-25	PS/2	
ACME	MS-03	PS/2	
AMICE	AGM201EP	USB	
AMICE	AGM202EP	PS/2	
AMICE	BTM-5632 (BTA-3100)	USB	Wireless
ANYTIME	CREBEP	PS/2	
A-PLUS	MS-1008	USB	
artmedia	EVT-P01	PS/2	
Arvel	WSMD-DVM	PS/2	
Asky	M058	USB	
ATake	HZ3003	PS/2	
BENQ	N300	USB	
Carrefour	MMS-001	USB	
Chic	CHIC-800	PS/2	
DELL	M056UC	USB	
Detroit	CanMouse CM313	USB	
Detroit	CanMouse CM317	USB	
Detroit	CanMouse CM337	USB	
e-Blue	WISH Optical Mouse	USB	
Elecom	M-N2UGY	USB	
EMI	AM-868U	USB	
Ergotech	ET-M6613	PS/2	

Manufacture	Model	Type	Remark
Ergotech	ET-M6673	USB	
Ergotech	ET-M6753	USB	
Ergotech	ET-M6913C(MU6)	USB	Wireless
Genius	NetMouse	PS/2	
Genius	NetScroll EYE Model: GM-03001P	PS/2	
Genius	MINI TRACKER Model: GM-04007A/U	USB	
Genius	EasyMouse PS/2	PS/2	
Genius	P801	PS/2	
Genius	K3P400A	PS/2	
Genius	MX-526	USB	
GOOD VISION	H3003	PS/2	
HAWK	12-OUM233	PS/2	
HP	5188-2466	PS/2	
HP	M-SBJ96	PS/2	
IBM	M032BO(A)	USB	
IBM	MO09BO	USB	
INTROPIC	Multi-Media Optical Mouse Model: MS-AM-2612U	USB	
INTROPIC	Optical Wheel Mouse Model: MS-005-B	USB	
I-Rock	Optical Mouse Model IR-7200	USB	
JS	PM-020(B07)	USB	
KINYO	Z30,Z100	PS/2	
KINYO	KM-V2	USB	
KINYO	KM-755	USB	
KINYO	KM-726	USB	
KINYO	H-3003	USB	
KOKUYO	EAM-UF1v	USB	
KRONE	MD-311/PS2	USB	
LANCE	LANCE 2000 G-Mouse	USB	

Manufacture	Model	Type	Remark
LASER-MOUSE	ML101	USB	
LEMEL	Browser Mouse	PS/2	
LEMEL	LW3-P	PS/2	
LEMEL	CHIC 730	PS/2	
LEMEL	10WCM-B700	PS/2	
Logitech	C-UM34	USB	Wireless
Logitech	Cordless Click optical mouse Model: M-RAA88 (C-BL4-MSE)	USB	Wireless
Logitech	Cordless Notebook Mouse Model: V200	USB	Wireless
Logitech	Cordless Optical Mouse Model: M-RR95 (C-BG17-DUAL)	USB	Wireless
Logitech	Cordless Desktop EX100	USB	Wireless
Logitech	Cordless Optical Mouse Model: CM-RR67A	USB	Wireless
Logitech	M-RY81CC (C-BK16A-DUAL)	USB	Wireless
Logitech	Cordless Wheel Mouse M-RK45	PS/2	Wireless
Logitech	Logitech Cordless Freedom Navigator	USB	
Logitech	MouseMan Wheel M-BD53	USB	
Logitech	Click Optical Mouse	USB	
Logitech	MouseMan Optical dual Sensor	USB	
Logitech	Optical Mouse MX300	USB	
Logitech	M-BD-53	PS/2	
Logitech	T-CL13	PS/2	
Logitech	M-SBF96	PS/2	
Logitech	M-S28-6MD	PS/2	
Logitech	M-S34	PS/2	
Logitech	M-S35	PS/2	
Logitech	M-S38	PS/2	
Logitech	M-CAA43	PS/2	
Logitech	M-S28-6MD	PS/2	
Logitech	M-UV96	USB	

Manufacture	Model	Type	Remark
Logitech	M-BJ58	USB	
Logitech	M-BP86	USB	
Logitech	M-BQ85	USB	
Logitech	M-BT96A	USB	
Logitech	C-UM34	USB	
Logitech	M-RY81CC (C-BK16A-DUAL)	USB	Wireless
Logitech	M-RR67A (BMS-07)	USB	Wireless
Logitech	S510	USB	Wireless
Logitech	M-RAK898(C-BO33)	USB	Wireless
Logitech	LASER V400	USB	Wireless
Logitech	MX Revolution	USB	Wireless
Logitech	MX 1100	USB	Wireless
Logitech	VX Nano	USB	Wireless
Logitech	M705	USB	Wireless
Logitech	M-BQ85	USB	
Logitech	QuickSilver Mouse 3KEY	PS/2	
Macally	UMF2	USB	
Macally	UMC3	USB	
MAXXTRO	Optical Wheel Mouse Model: MH-004	USB	
Microsoft	Wireless Optical Mouse P/N: X09-58309	USB	Wireless
Microsoft	Wireless Optical Mouse 2.0 Model:1008	USB	Wireless
Microsoft	IntellMouse Optical 1.1 P/N: X08-07940	USB	
Microsoft	Wheel Mouse P/N: X03-53717	PS/2	
Microsoft	P/N: X09-13962	USB	
Microsoft	Optical Mouse by Starck Model: 75578-492	USB	
Microsoft	Compact Optical Mouse P/N: X802055-002	USB	

Manufacture	Model	Type	Remark
Microsoft	Basic Optical Mouse	USB	
Microsoft	Wheel Mouse Optical	USB	
Microsoft	Optical Mouse Blue	USB	
Microsoft	IntelliMouse Optical	USB	
Microsoft	Notebook Optical Mouse	USB	
Microsoft	Wireless IntelliMouse Explorer 2.0	USB	
Microsoft	TrackBall Explorer 1.0 PS/2 USB	USB	
Microsoft	Microsoft IntelliMouse	USB	
Microsoft	X03-53717	USB	
Microsoft	1016(X802055-002)	USB	
Microsoft	X08-99489	USB	
Microsoft	X09-13962	USB	
Microsoft	Model-1025	USB	
Microsoft	1030	USB	
Microsoft	ET537	Wireless	
Microsoft	ET733	Wireless	
MITAC	MS MW3-P	PS/2	
MITSUBISHI	AirMouse	PS/2	
MSI	StartMouse	USB	
NEC	MS-DC-7006	PS/2	
OPTICAL	MX-526	USB	
Oporite	LASER MOUSE Model: ML 101	USB	
QSKY	M058	USB	
SAMAUNG	MUY	USB	
SAMAUNG	SPM-7000X	USB	
SAMAUNG	SPM-4000	USB	
SANYO	SYMS-1606	USB	Wireless
SANYO	SYMS-1602	USB	
SANYO	SYS-EI	USB	
SEGATE	BROWS MOUSE	PS/2	
Sensetive	Z-WHEEL	USB	
SHARP	SHARP USB Mouse (CE-MS02)	USB	

Manufacture	Model	Type	Remark
SONY	VGP-UMS50	USB	
SUN MICROSYSTEMS	Crossbow USB P/N: 370-3632-01	USB	
SVPA	Mouse Clicker M01	PS/2	
SYNNEX	SCROLLING MOUSE Model: 0107	PS/2	
T.C.STAR	TCM920	USB	Wireless
T.C.STAR	Optical Mouse Model: TCM560N	USB	
TOP-TINT	MP-5020-E2	USB	
TOSHIBA	IPC5017A	USB	
ViewSonic	ViewMate Optical Mouse Model: VS10212	USB	
WINTEK	3D Internet Mouse Model: WSS23	PS/2	
WINTEK	Optical Wheel Mouse Model: WSS36	USB	
WINTEK	3D Internet Mouse Model: WSS56	USB	
WINTEK	Optical Wheel Mouse Model: WSS60	USB	
X-PRO	Optical Mouse Model: A3004045	USB	

12.2. Keyboard Compatibility Table

Manufacture	Model	Type	Remark
A Tale	KN-558	USB	
A4-TECH	KB-70	PS/2	
A4-TECH	KBS-27PU	USB	
A4-TECH	KL-23MU	PS/2	
ADI	647H-K -BPS/2	PS/2	
AMICE	KB-0420	PS/2	
ASUS	K7000	USB	

Manufacture	Model	Type	Remark
Atake	KJ-118	PS/2	
BEAUTY	NBK-2198-PS/2	PS/2	
BENQ	6511-VA	PS/2	
BENQ	A800	PS/2	
BTC	5123	PS/2	
BTC	5140	PS/2	
BTC	5301	PS/2	
BTC	5197	PS/2	
BTC	5123W	PS/2	
BTC	E5XKB5301	PS/2	
Certified	E5XKBM104M10UC	PS/2	
Chicony	9850	PS/2	
COMPAQ	6133-006	PS/2	
COMPAQ	KU-9978	USB	
DELL	SK-8110	PS/2	
DELL	SK-8115	USB	
DTROIS	RUNNER 1000	USB	
EAGLE TOUCH	SKB-2200	USB	
Elecom	TK-LU2BSVB(10Keys)	USB	
Esense	13-EWK240	USB	Wireless
Ergotech	ET-K701	PS/2	
EzKey	EZ-6000-PS/2	PS/2	
FREE WILL	KD-558	USB	
FUJIEI	SK0054	PS/2	
GENIUS	KU-0368	USB	
GENUINE	9001A	PS/2	
Genuine	KKB-2050HS	USB	
GVC	5198-PS/2	PS/2	
HAWK	13-HME821	PS/2	
HP	KU-9970	USB	
IBM	SK-8809	USB	
IBM	0225	PS/2	
IBM	KB9930	PS/2	

Manufacture	Model	Type	Remark
IBM	KB9939	PS/2	
INNOVAT	IT-3100	PS/2	
I-ROCKS	KR-6130	USB	
JI-HAW	KW-3230	PS/2	
KINYO	KBW71	PS/2	
KRONE	9810	USB	
LEMEL	5201-PS/2	PS/2	
LEMEL	KB-5106-P-PS/2	PS/2	
Logitech	Cordless Desktop EX100 Model: Y-RH35 RT7R06	USB	Wireless
Logitech	Cordless Keyboard Model: Y-RJ20 (BMS-09)	USB	Wireless
Logitech	Cordless Desktop EX100 Model: Y-RQ57	USB	Wireless
Logitech	Cordless Keyboard Model: Y-RAK73 (BMS-07)	USB	Wireless
Logitech	Cordless Keyboard Model: Y-RR54 (BMS-07)	USB	Wireless
Logitech	Cordless iToch Keyboard Model: Y-RB6	PS/2	Wireless
Logitech	Cordless Keyboard Model: Y-PH35 (BMS-07)	USB	Wireless
Logitech	Cordless Keyboard Model: K320	USB	Wireless
Logitech	RUNNER-1000-PS/2	USB	Wireless
Logitech	Logitech Internet Navigator Keyboard	USB	
Logitech	Logitech Cordless Freedom Navigator	USB	
Logitech	Y-SA2-PS/2	PS/2	
Logitech	Y-SJ17-PS/2	PS/2	
Logitech	WK-620	PS/2	
Logitech	Y-BF37	USB	
Logitech	Y-BL49	USB	

Manufacture	Model	Type	Remark
Logitech	Y-BP62a	USB	
Logitech	Y-SM46	PS/2	
Logitech	Y-SS36	PS/2	
Logitech	Y-SX49	PS/2	
MEMOREX	MX-3300	USB	
Microsoft	Wireless MultiMedia Keyboard 1.1 Model:1014	USB	Wireless
Microsoft	Microsoft Digital Media Pro Keyboard	USB	
Microsoft	Microsoft Natural Keyboard Elite	USB	
Microsoft	EZ-6000	USB	
Microsoft	kc-0405	USB	
Microsoft	RT9401	USB	
Microsoft	RT9480	PS/2	
Microsoft	W0R313	USB	Wireless
Microsoft	X09-51329	PS/2	
NEC	CKBM-001-PS/2	PS/2	
Novia	F-21BQ	PS/2	
Power SYNC	KB6969	PS/2	
PRESIDENT	VIGA-106	PS/2	
RCS	KB-6168-BPS/2	PS/2	
ROGALD	KB-006	USB	
SAMSUNG	PKB-8000	USB	
SMART K/B	EZ-6000	PS/2	
SOFT	F-21BQ	PS/2	
SOFT	F-21SQ-PS/2	PS/2	
SOFT	F-21BQ	PS/2	
Song.Win	KCM-60	USB	
Song.Win	MCK-780	USB	
SORG.WIN	MCK-01P	PS/2	
State	KB-8001R+-PS/2	PS/2	
SUN	M860-8706-T216	USB	
TC.STAR	ACK-2070UM	USB	
TC.STAR	K378	PS/2	

Manufacture	Model	Type	Remark
TC.STAR	TCK220	USB	
TC.STAR	TCK960	USB	Wireless
TURBO-JET	8801RE+W	PS/2	
U-Sheng	VIGA-106	PS/2	
View Sonic	VS10297	USB	
WINTEK	WK-220	USB	
WINTEK	WK-370	USB	
WINTEK	WK-808/KT-808	USB	
WINTEK	WK-808S	PS/2	
YAMA	CYKB-03	USB	
ZIPPY	WK-880	USB	
ZIPPY	WK-620	USB	

Two-Year Limited Warranty

Raritan, Inc. (hereinafter referred to as "Raritan") warrants the Raritan product to be in good working order for a period of two (2) years from the date of purchase from Raritan or an authorized Raritan reseller. Should this product fail to be in good working order at any time during this two-year warranty period, please contact Raritan for technical service. This Two-Year Limited Warranty does not include repair of damage to the product resulting from accident, disaster, misuse, abuse, non-Raritan modification of the product, nor other events outside of Raritan's reasonable control or not arising under normal operating conditions. Raritan makes no other warranty, either expressed or implied, with respect to this product. Raritan specifically disclaims the implied warranties of merchantability and fitness for a particular purpose, in particular, in hospital critical care life-support systems. If this product is not in good working order as warranted above, your sole remedy shall be repair or replacement as provided above and shall not exceed the price of the defective individual product, which is basis for a claim. In no event will Raritan nor its resellers or suppliers be liable to you for direct, indirect, incidental, or consequential damages resulting from any defect in the product or in the manual. In no event shall Raritan be liable for any loss of profits, loss of equipment or facilities, or the loss of any software programs or data or the cost of recovering or reproducing the programs or data.

Obtaining Technical Service

To obtain warranty service for a product, contact Raritan Technical Support. It is helpful to call from a phone located near the product in question; we can probably solve your problem directly over the phone. During the warranty period, Raritan provides, without charge, certain types of repair and exchange service to keep products in, or restore them to, conformance with their specifications. At its discretion, Raritan will either repair or exchange the failing product. Repair parts and replacement products will be furnished on an exchange basis and will be either new, remanufactured or refurbished, at Raritan's discretion. The replacement products will be warranted for the remainder of the warranty period or thirty days, whichever is greater. All replaced parts and products become the property of Raritan.

To return your product, Raritan will provide you a Return Merchandise Authorization Number (RMA#). The RMA# must appear on the outside of the package and the items must be shipped to Raritan using the provided labels. Raritan cannot accept collect shipments. The RMA# will be voided and you will be invoiced for any advance replacement units, if the RMA material is not received within 30 days of issue. In the event that a returned product arrives with an invalid or voided RMA#, it will be returned to the sender at the sender's expense. Raritan is not responsible for any material without a valid RMA#.

You represent that all returned items are genuine and unaltered. The replacement may not be new, but will be in good working order and at least functionally equivalent to the item replaced. The replacement assumes the warranty service status of the replaced item. Many features, conversions, or upgrades involve the removal of parts and their return to Raritan. A part that replaces a removed part will assume the warranty service status of the removed part. Before Raritan or your reseller exchanges a product or part, you agree to remove all features, parts, options, alterations, and attachments not under warranty service.

Raritan is responsible for the loss of or damage to your Product while it is 1) in Raritan's possession or 2) in transit in those cases where Raritan is responsible for the transportation charges. Neither Raritan nor your reseller is responsible for any of your confidential, proprietary or personal Information contained in a Product which you return to Raritan or your reseller for any reason. You should remove all such information from the Product prior to its return.



Governing Law

Both you and Raritan consent to the application of the laws of the country in which you acquired the Product to govern, interpret, and enforce all of your and Raritan's rights, duties, and obligations arising from, or relating in any manner to, the subject matter of this Agreement, without regard to conflict of law principles.

TO ACTIVATE TECHNICAL SUPPORT AND SERVICE, REGISTER YOUR PRODUCT TODAY.

Register online and receive Free Advanced Replacement with your Two Year Limited Warranty.

www.raritan.com/standard_warranty





Guardian Support Services Standard – Two Year Limited Warranty

Please record your purchase information for future reference.

Serial Number: _____

Product Purchase Date: _____

P/N: _____

Purchased From: _____

Dealer's Phone Number: _____

Extended Warranty Plan: _____

Date of Purchase: _____

Expiration Date: _____

Technical Support:

America
Tel (732) 764-8886
Fax (732) 764-8887

Europe
(31) 10-284-4040
(31) 10-284-4049

Asia
(886) 2-8919-1333
(886) 2-8919-1338

Japan
(81) 3-5795-3170
(81) 3-5795-3171

www.raritan.com



Raritan, Inc. 400 Cottontail Lane Somerset, NJ 08873 Tel: 800.724.8090 Fax: 732.764.8887 e-mail: warranty@raritan.com



*expres***ZO**
by Raritan

 **Raritan.**