

Power-Flite[®]

COMMERCIAL FLOOR CARE EQUIPMENT

Drum Sander

OPERATING INSTRUCTIONS

COMMERCIAL DRUM SANDER

CONGRATULATIONS

YOU HAVE JUST ACQUIRED A HIGH QUALITY DRUM SANDER. PLEASE READ THIS MANUAL CAREFULLY BEFORE OPERATING YOUR NEW SANDER. KEEP MANUAL ON HAND FOR FURTHER REFERENCES.



Save These Instructions

SAVE THESE INSTRUCTIONS FOR FUTURE REFERENCE

*When using an electrical cleaner, basic precautions should be followed.

*Read all instructions before using sander.

Safety Instructions	1-2
Important parts of the machine	3-4
How to assemble the machine	
Dust suction tube and bag	5
Setting up the machine	
Leveling the machine	6
Sandpaper installation	7
Sanding drum pressure	7
Starting the motor	8
Instructions for electrical connection to 115V	8
How to operate the machine	10
Maintenance	
Changing and adjusting the Poly - V Belt.	11
Sanding drum maintenance	11
Maintenance of the wheels	11
Prevention maintenance	11
Troubleshooting	12-13
Assembly drawing and spare parts list.. . . .	14-17

This manual aims to help you use and take good care of this machine over the years for which we offer you our warranty as manufacturers as well as our technical assistance service.

Always keep this manual to hand. Many of the instructions and recommendations will be familiar and well-known to you.

Should this not be the case, apply these instructions and recommendations correctly and you will obtain excellent results, safety and satisfaction.

It is important to remember that reading this manual carefully can help you to prolong the life of your machine as it will ensure its correct use. Inspect your machine on receipt, make sure that

it has not been damaged during the transport. Check the contents of the box to ensure that not accessories are missing.

As always, we thank you for placing your confidence in a Powr-Flite product.

Single-phase AC motor	115V - 60Hz.
Motor power	1,5 HP.
Sanding drum8"
Drum r.p.m.	2 200 r.p.m.
Suction fan speed6 800 r.p.m.
Machine weight	133 lbs
Gross weight	155 lbs

SAFETY INSTRUCTIONS

To reduce the risk of fire, electric shock and personal injury when using electrical tools, the following basic safety precautions should always be taken.

Read these instructions carefully before operating or attempting to carry out any service or maintenance procedure on this product.

- You must have been trained to operate this machine before using it.
- Machines can cause flammable materials and vapors to burn. Do not use the machine with or near solvents, thinners, fuels, or other flammable materials.
- To prevent the risk of fire or explosion:
 - a) Keep the machine away from sources of ignition, as they could create an explosion during use.
 - b) Keep the work area well ventilated. Poorly ventilated work areas can create an explosive atmosphere when they contain solvents, alcohol, thinners, certain finishes or any kind of combustible material.
 - c) Never leave a full dust bag in the machine. Remove the dust bag when you have finished your work.
 - d) Empty the dust bag when it is 1/3 full.
 - e) Always empty the sanding dust into a metal container. This container must be outside the building.
 - f) Do not put the contents of the dust bag into a fire or furnace.
 - g) Use a hammer and punch to set all the nails flush against the floor so that the sanding drum will not touch them and create sparks which might cause a fire in the dust bag.
- Do not use the machine if it is not completely assembled.
- To prevent electric shocks and personal injury, always disconnect the power supply before changing the sandpaper, emptying the dust bag, leaving the machine unattended or attempting any maintenance or service.
- To prevent electric shocks, avoid contact with grounded surfaces, i.e. pipes, radiators, refrigerators, etc.
- Do not expose the machine to rain. Keep the electrical parts dry.
- The machine should be stored in a dry place and out of the reach of children.
- Check the cable and plugs and replace them if damaged. Do not use the machine if the cable is damaged. Keep the cable away from heat, oil, water and sharp edges.
- Always connect the machine to a grounded power supply. Never disconnect the ground cable from the machine.
- Always use a cable with 3-wire size of 14 gauge and connect the machine to a grounded plug. Ensure that the plug really does have a ground connection.
- Make sure that the power switch is in the "0" position before connecting the cable to the electrical power supply.

SAFETY INSTRUCTIONS

To reduce the risk of fire, electric shock and personal injury when using electrical tools, the following basic safety precautions should always be taken.

Read these instructions carefully before operating or attempting to carry out any service or maintenance procedure on this product.

- Keep the cable away from the underside of the machine to avoid contact with the sandpaper as this could cause electrocution. Always keep the cable on top of the machine.
- Moving parts can cause injury and/or damage. Keep hands, feet and loose clothing away from all the moving parts of the machine.
- Make sure that all guards, doors and covers are secure and in place before starting to sand.
- Check that all warning labels are legible and duly stuck on to the machine. Should any of them become damaged or illegible, replace them immediately. Ask the authorized distributor for new labels.
- Make sure that the person who is going to use the machine has read this manual beforehand.
- Do not use this machine as a step or furniture.
- Do not use this machine for moving other objects or people.
- This machine is heavy. Separate the suction tube if you are going to transport it single-handed. Trying to lift this machine single-handed could cause serious back injuries. Always get help to lift the complete machine.
- Always use a face or dust mask if the sanding operation is dusty.
- Stay alert. Watch what you are doing. Use common sense. Do not operate the machine when you are tired. Keep proper footing and balance at all times. Wear ear protection when using the machine for long periods. Hold the machine tightly with two hands while working.
- Always disconnect the machine when not in use, before servicing and when changing accessories.
- Never carry the machine by its cable or wrench it out of the socket.
- Always keep children away from the machine. Visitors should be kept away from the work area.
- Using accessories or attachments other than those recommended in this instruction manual could cause personal injury.
- Check the machine for damaged parts before use. Check for breakage, insufficient mounting, misalignment or poor binding of moving parts and anything else that may affect operation.
- Do not use the machine if the on-off switch does not work correctly. Defective switches must be replaced by an authorized servicing center.

IMPORTANT PARTS OF THE MACHINE

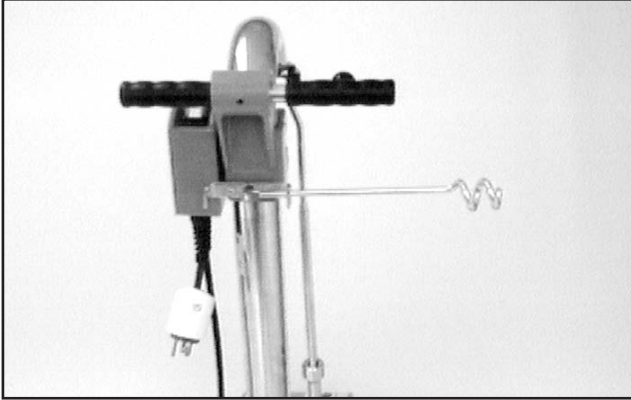

Fig. 1

Cable Holder

This sander has a cable holder that could be moved to the right or left side of the machine. (fig. 1)

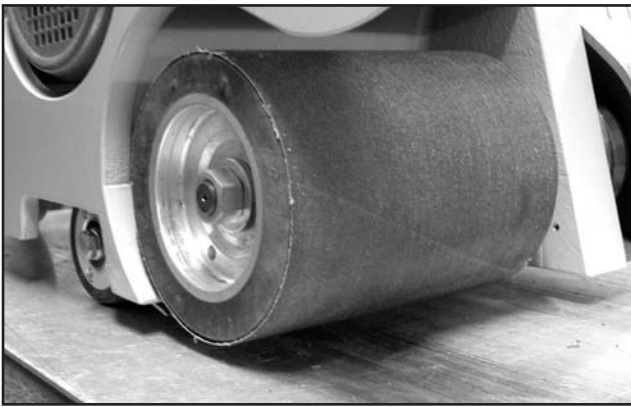

Fig. 2

Sanding Drums

The machine is designed to work with three different types of drums:

Expandable Drum (fig. 2)

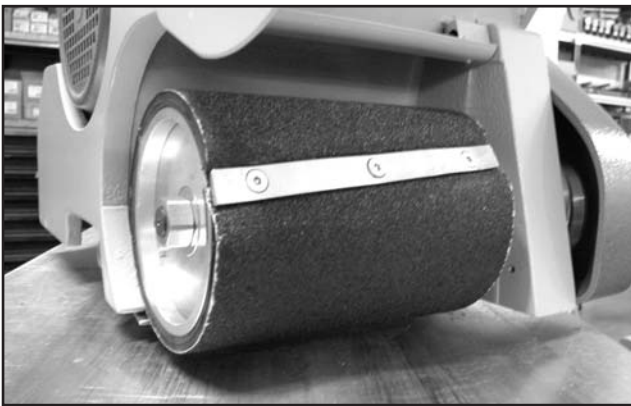

Fig. 3

Bar Clamp Drum (fig. 3)

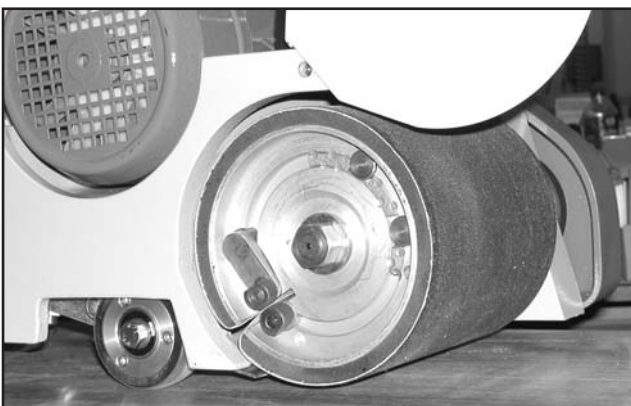

Fig. 4

Conventional Drum (fig. 4)

IMPORTANT PARTS OF THE MACHINE

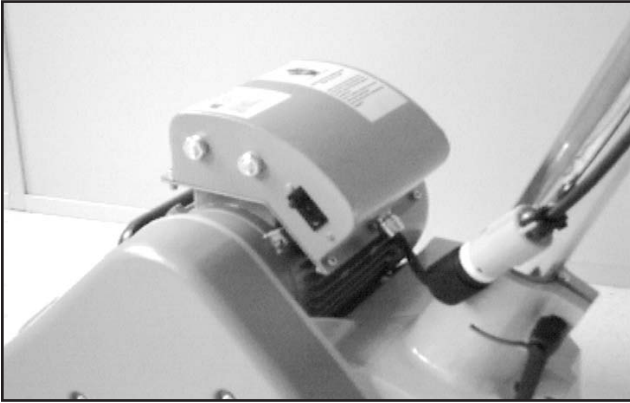

Fig. 5

Electric Motor

The machine has a maintenance-free single-phase heavy duty AC motor.

Power supply: 115 V/60 Hz only.

Overload protection by circuit breaker. (fig. 5)

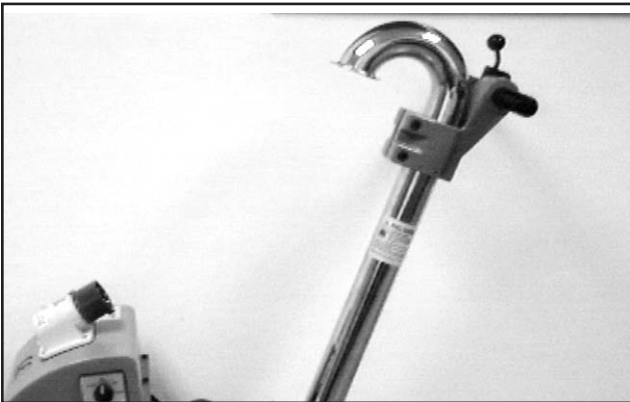

Fig. 6

Suction Dust Tube

The suction dust tube is placed at the back of the machine next to the handle and lever for controlling the sanding drum. (fig. 6)



Fig. 7

Dust Bag

The dust bag must be fastened in place before using the machine as in fig. 7.

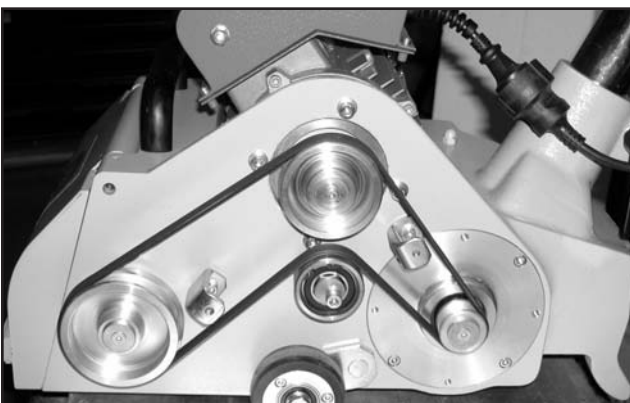

Fig. 8

Poly V Belt Slack Adjuster

The machine has one poly V belt for turning the drum and the suction fan.

The drive belt is adjusted with belt slack adjuster. (fig. 8)

HOW TO ASSEMBLE THE MACHINE

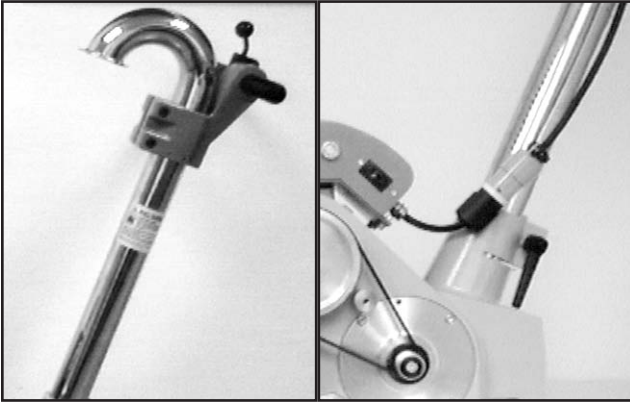

Fig. 9

Dust Suction Tube and Bag

To fit and adjust the dust suction tube and bag, proceed as follows:

1. Fit the dust suction tube in place. (fig. 9)

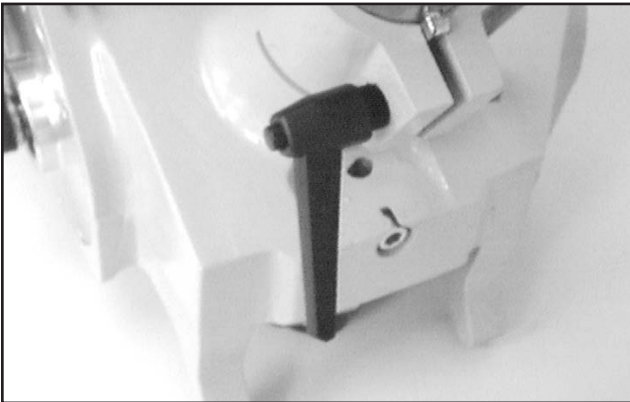

Fig. 10

2. Adjust the screw holding the tube. (fig. 10)



Fig. 11

3. Attach the drum control lever. (fig. 11-12)



Fig. 12

4. Clip the dust bag tightly to the dust suction tube.

SETTING UP THE MACHINE

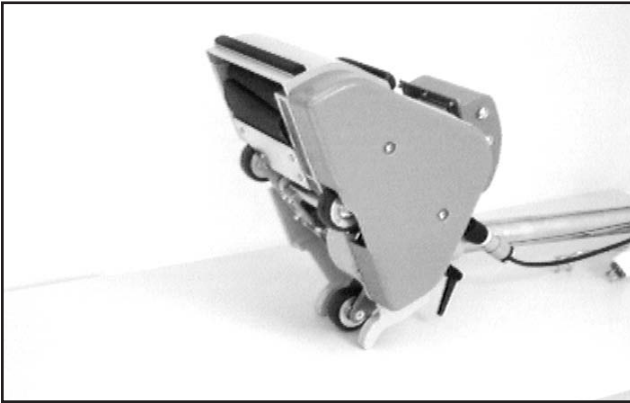

Fig. 13

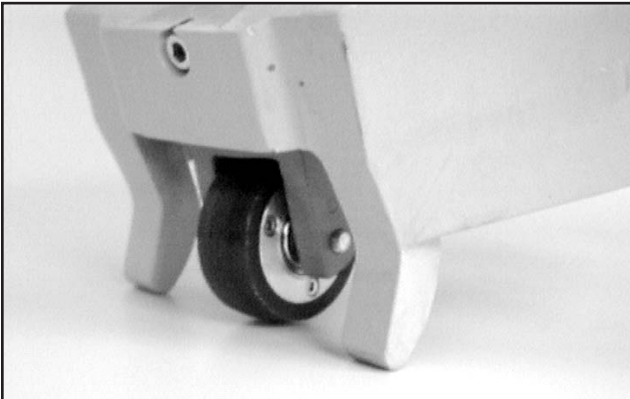

Fig. 14



Fig. 15

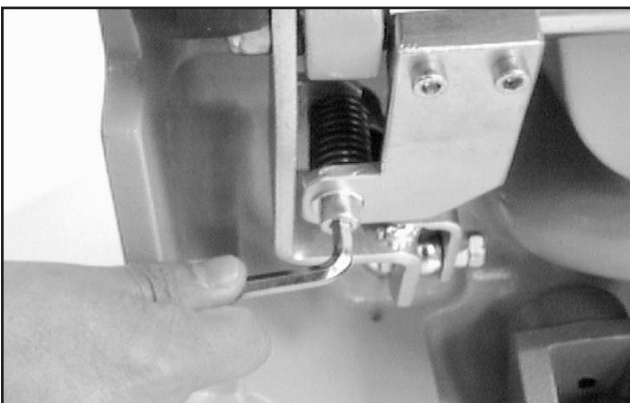

Fig. 16

Leveling the Machine

To level your sander horizontally proceed as follows:

Tilt the machine as in fig. 13-14.

The machine has an adjustable system in order to level the machine when required. (fig. 15)

Loosen the leveling screw to sand heavier on drive belt side of the sanding drum.

Tighten the leveling screw to sand heavier on the side opposite the drive belt. (fig. 16)

SETTING UP THE MACHINE

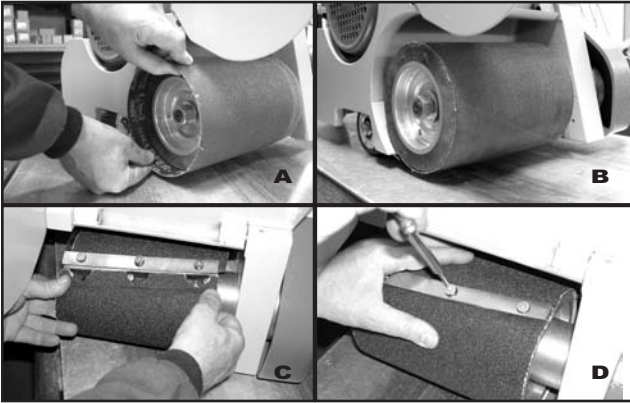

Fig. 17

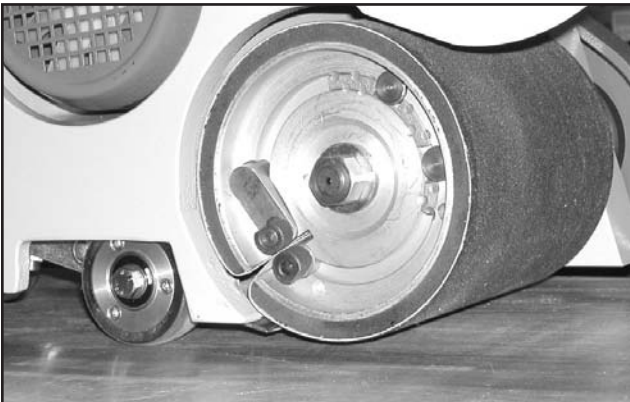

Fig. 18

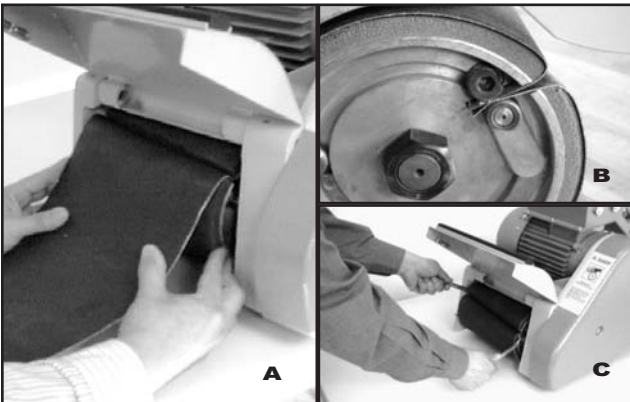

Fig. 19

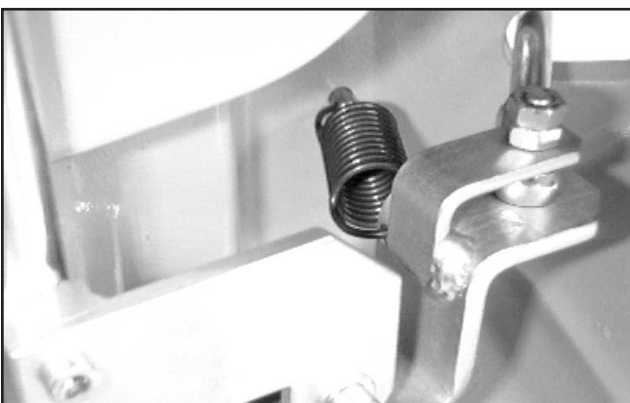

Fig. 20

Sandpaper Installation

To install and adjust the sandpaper, proceed as follows:

- EXPANDABLE DRUM:

- This type of drum uses sandpaper which you slide onto the drum. When the drum spins, the rubber expands and holds the sanding belt. (fig.18a,b)

- BAR CLAMP DRUM:

- Easy access to the drum allows quick change of the sandpaper. A metal bar with screws holds the sandpaper on the drum. (fig. 18c,d)

- CONVENTIONAL DRUM:

- Cut the sandpaper to the same size as the pattern provided with the machine.

- Raise the lid covering the drum (fig. 18).

- Insert one side of the sandpaper into the slot on the drum, turn the drum around until it is covered with sandpaper and insert the other extreme into the same slot (fig. 19a,b)

- Use both keys to adjust the sandpaper against the drum by turning one key forward and the other backward, as in (fig. 19c)

- Make sure that the sandpaper has been correctly inserted.

Sanding Drum Pressure

The machine has only one sanding drum pressure controlled by spring. (fig. 20).

SETTING UP THE MACHINE



Fig. 21

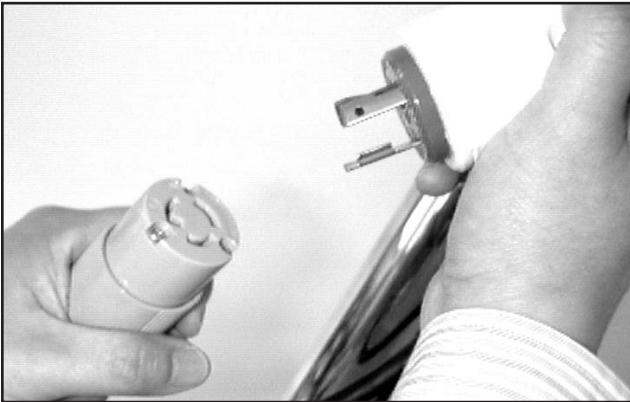

Fig. 22

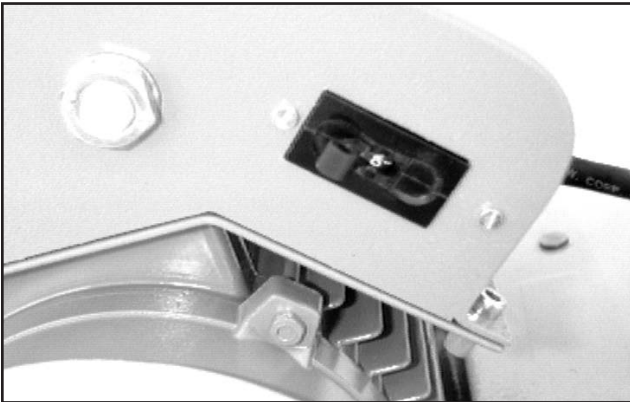

Fig. 23



Fig. 24

Starting the Motor

To operate the machine follow this procedure:

Connection to 115V (single-phase)

1. Connect the handle pigtail to the motor cord.
(fig. 21)

2. Connect the handle pigtail to the power cord.
(fig. 22)

3. Make sure that the circuit breaker placed at one side of the electrical box of the motor is in the "ON" position. (fig. 23)

4. the machine has a double-bladed safety switch under voltage release. The "front" position is used to start the motor and the "rear" position to stop the motor. (fig. 24)

SETTING UP THE MACHINE

This machine must only be connected to an AC frequency at the electrical voltage shown on the motor plate (115V/60 Hz).

- To prevent electric shock keep the machine in a dry place.
- Do not expose the machine to rain.
- The machine cable and connection plugs must be in perfect condition.
- Unplug the machine after use.
- The machine must be connected to a grounded electrical circuit in order to protect the operator from electric shocks.
- Make sure that you are connecting the machine to 115V.
- When connecting to 115V, make sure that the electrical circuit in the house or building is grounded.
- Do not cut, remove or break the ground pin.
- Do not use a machine with a damaged plug or cable.
- Do not use the machine if the on-off switch doesn't work correctly.
- Avoid reductions in voltage, use 3-wire size of 14 gauge cables measuring no longer than 30 meters.

HOW TO OPERATE THE MACHINE



Fig. 25

After starting the motor, the operator must stand behind the machine and hold it in place with both hands. (fig. 25)



Fig. 26

Move the machine forward slowly and push down the drum control lever. (fig. 26)

Move the machine slowly and constantly.

Before reaching the end of the area to be sanded, lift the drum gently. (fig. 27)

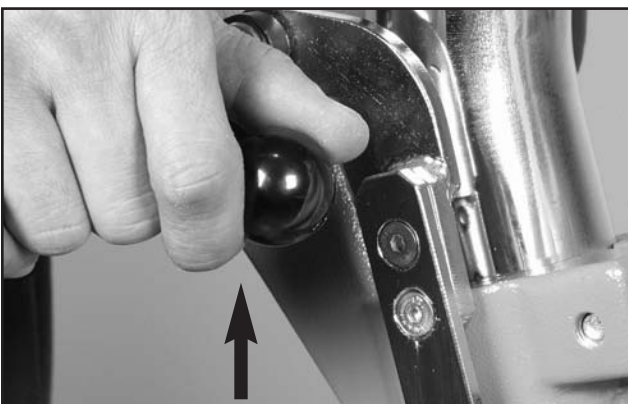

Fig. 27

Pull the machine back over the mark it left when it started moving, lowering the drum gently when you start the backward movement.

Keep the sander in motion while the drum is working or marks will appear which are very difficult to remove with further sanding.

Always work from left to right.

In order to obtain satisfactory sanding, the sander should be passed over the surface several times with different sizes of sanding grain.

We recommend that the sander be passed over the surface at least three times if the floor is new. If the floor in question has already been varnished we recommend that the sander be passed four times, according to the following chart:

Passes	New floors	Old floors
first	grit 30-35	grit 24
second	grit 60	grit 36-40
third	grit 100	grit 60
fourth		grit 100

MAINTENANCE

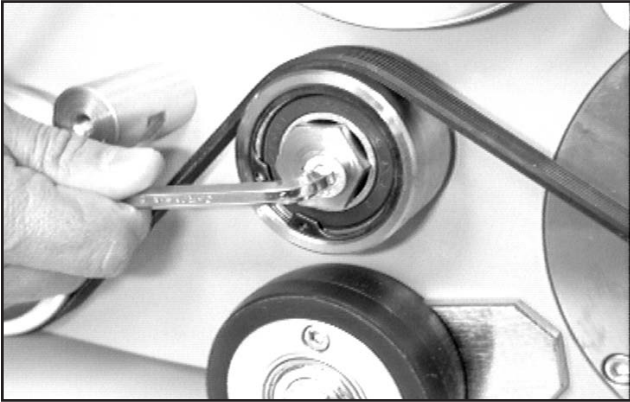

Fig. 28

Changing and Adjusting the Belt

It is important to check the tension of the Poly - V belt and change it if necessary. Loosen the screw to adjust or change the belt and then tighten it.

The belt must not be too tight or too loose.

Remember that an over-tight belt makes it difficult to start the motor and that the drum will turn freely if they are too loose (fig. 28).

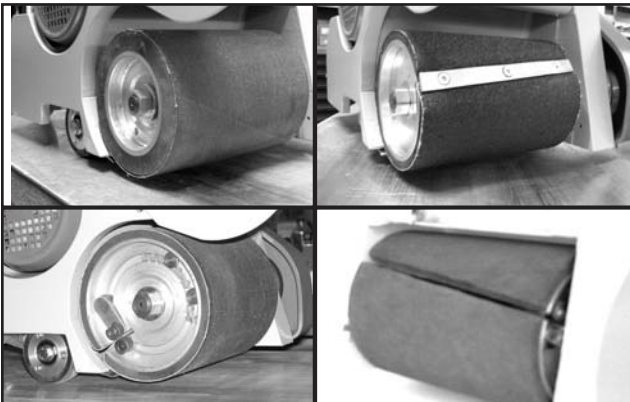

Fig. 29

Sanding Drum Maintenance

Check that the drum surface is in good condition and that there is no sawdust inside it, as this could throw it off balance (fig. 29).

Clean the sanding drum from time to time, using air to clean out the drum chamber.



Fig. 30

Maintenance of the Wheels

Check the wheels periodically (fig. 30).

- Make sure that the surfaces do not have glue or debris stuck to them.
- Change them when worn.
- Clean the bearings with air.

Prevention Maintenance

In order to avoid inconvenient setbacks, we suggest that you carry the following along with your normal tools:

- a Poly - V belt.
- a dust bag.
- a set of capacitors.

In this way you will be sure that your machine will always function.

TROUBLESHOOTING

- Below we offer a series of suggestions which will enable you to resolve some of the most frequent problems which arise when sanding wooden floors.

Poly V Belt

- Sometimes the belt will make a noise as if it is slipping. This means that it is not fitted tightly enough or that it is worn and needs changing.

Ball Bearings

- The ball bearings are protected against dust and are self-lubricating. However, they have a limited life span depending on the amount of time the machine is in use.
- By way of indication, their useable life is approximately:

Fan shaft	2500 hrs of use.
Motor shaft	5000 hrs of use.
Drum shaft	5000 hrs of use.

- No matter what the case, if you hear a strange noise, check whether it is coming from the drum, motor or fan. Run the motor together with the drum alone and then the motor with the suction tube alone, which will make it easy to pinpoint the noise. Once found, the faulty bearing has to be changed.

The Fan

- Should you notice that the fan is not turning, the machine is not vacuuming, and that the fan belt is making a slipping noise, STOP THE MOTOR.

Chances are that the machine will have sucked in a nail, a piece of wood or any other foreign body which will have blocked the blades of the fan. To solve this problem, try to turn the blades manually and remove the foreign body that is blocking it.

Sanding Drum

- First, clean the floor to make sure that there are no nails lying around.
- Brush the floor before sanding to avoid remains of materials which could damage the rubber drum.

Sandpaper

- Take care not to insert sandpaper which is too long, as this will cause it to fold and leave marks on the floor. It could also cause the sandpaper to break while working.

The Motor

- If the motor functions haltingly once it has been switched on and set in motion, this means that:
 - a)The electric voltage is too low.
 - b)The cable is too long or the cross-section is inappropriate.
 - c)The work capacitor is defective.
 - d)The motor is defective.
- If the motor does not start, this means that:
 - a)The electric voltage is too low.
 - b)The starting capacitor is defective.
 - c)There is no electricity in the plug.

TROUBLESHOOTING

- d)The cable pins are not properly connected.
- e)The motor is defective.

- Should the demand limiter jump when the motor is started, it means that the house has less than 15 amps. If this happens, **DO NOT INSIST ON TRYING TO MAKE IT START**, as you will only succeed in burning the capacitor.

Level of the Machine

- If you observe that the machine is sanding more on one side than the other, it means that it is not exactly levelled. See the section Leveling the machine in this manual.

Dwell Marks on Floor

- These usually appear on the floor like a thread after the last sanding (fine grain). This is because a tiny stone has left a mark on the sandpaper which, in turn, is leaving a thread-like mark on the floor. The solution is to change the sandpaper and clean the floor well before passing the fine-grain sandpaper.
- Sawdust, glue or any kind of material which sticks to the wheels can leave marks on the floor.
- Always make sure that the wheels are completely clean before sanding.
- Excessively long pieces of sandpaper can create a fold on the drum and cause marks. Avoid this anomaly by cutting the piece of sandpaper to exactly the same shape as the sample provided with the machine.

- Any material leftovers which get stuck between the drum and the sandpaper can also leave marks on the floor. Always check the surface of the drum to ensure that it is clean and in good condition.
- When using the machine, try to maintain a uniform and constant sanding speed. Otherwise, marks might appear on the floor.
- Lowering the drum too quickly will cause marks, which will be even more obvious if you pass over them again in the same direction. The best way to correct "dead stops" is by sanding the mark on the floor at 45°.

The Capacitors

- Always carry a spare set of capacitor with you.
- If the building has a voltage lower than 115V, you might have problems starting the motor. In winter, with low temperatures, the belts and interior of the bearings stiffen, meaning that the motor might take longer to start.

DO NOT INSIST ON TRYING TO START THE MOTOR. This will only cause the capacitor to burn out.

ASSEMBLY DRAWING AND SPARE PARTS LIST

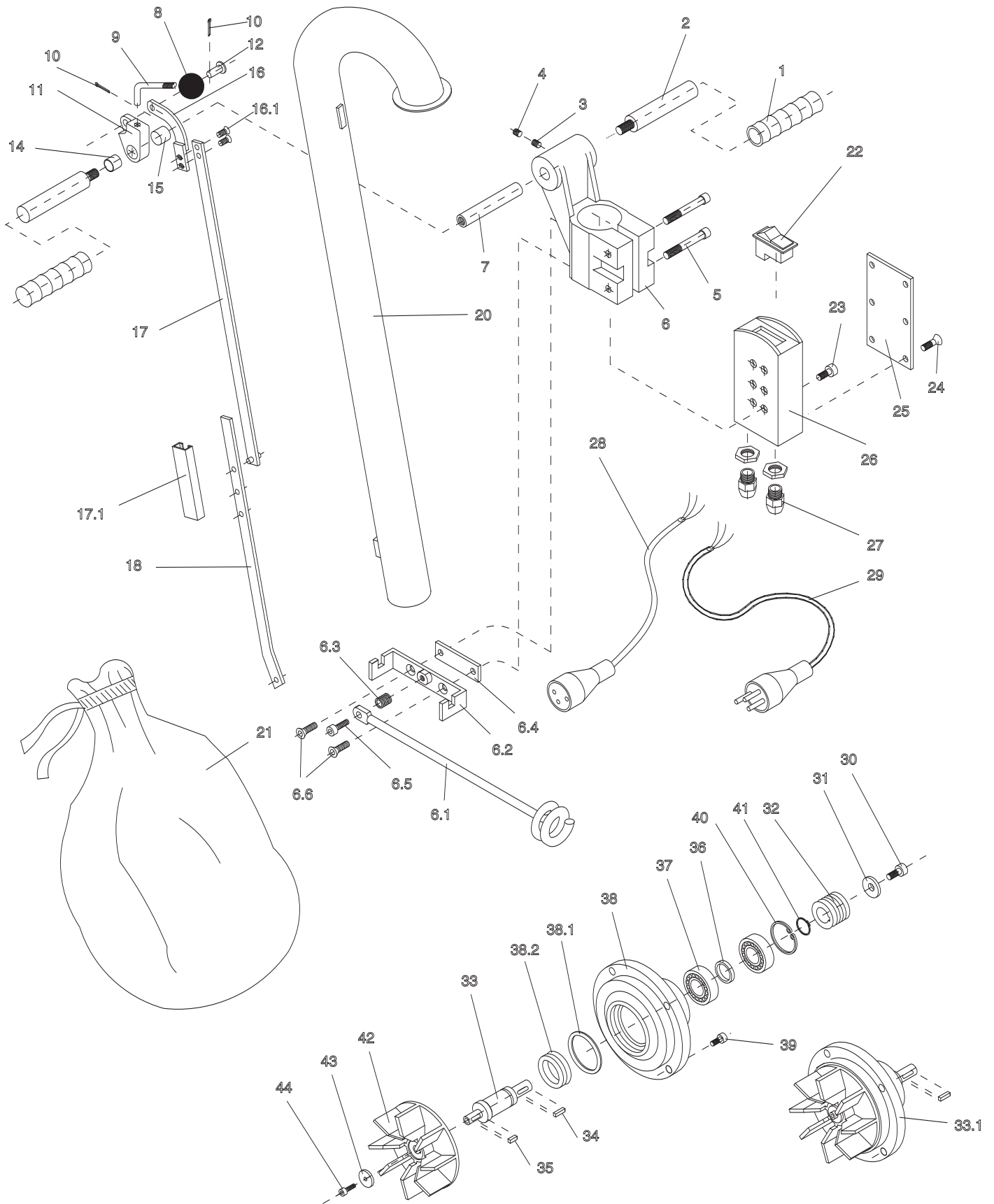

ASSEMBLY DRAWING AND SPARE PARTS LIST

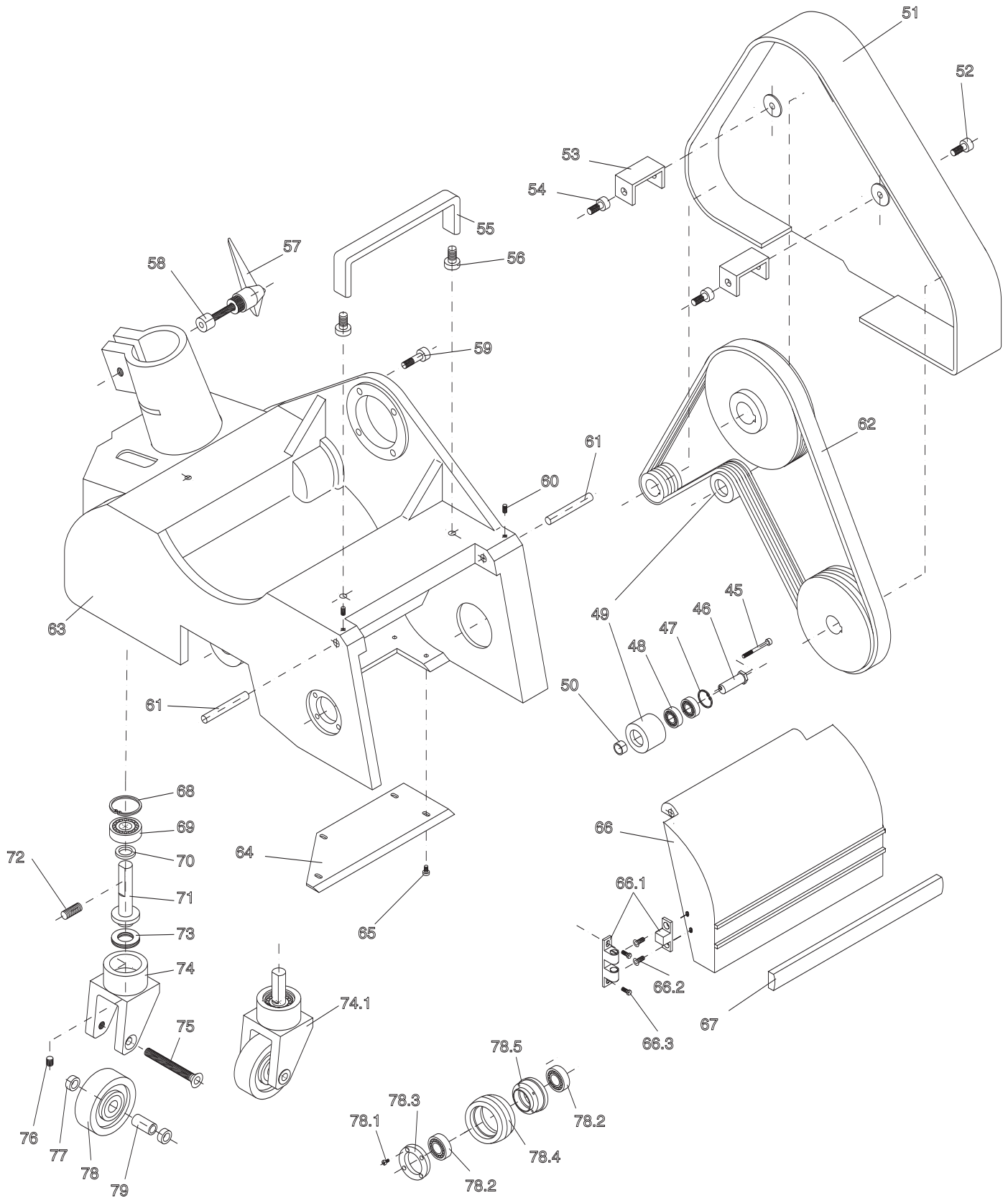

ASSEMBLY DRAWING AND SPARE PARTS LIST

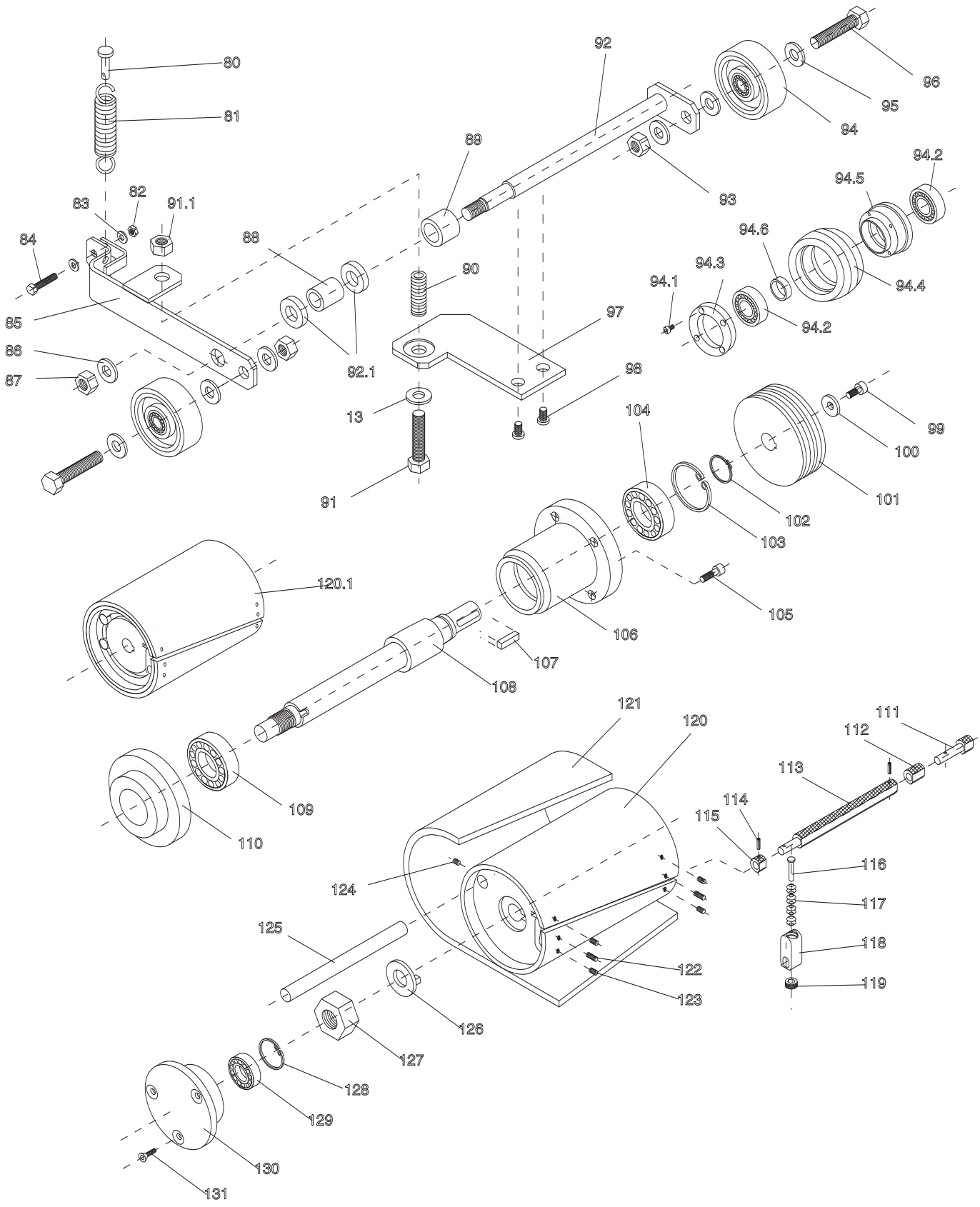

ASSEMBLY DRAWING AND SPARE PARTS LIST

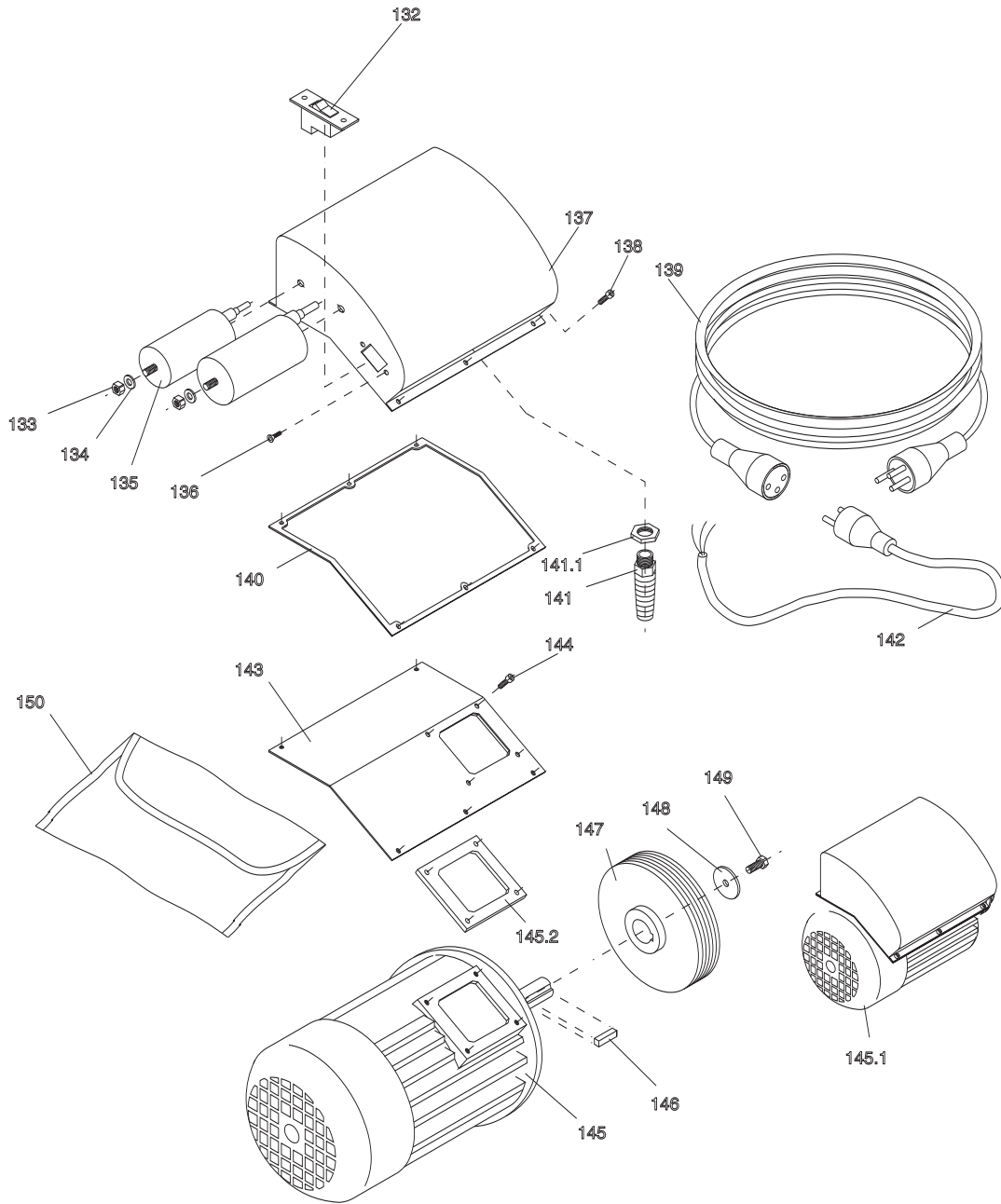

ref#	part #	desc
6.1	SD100	CABLE HOLDER
8	SD101	BALL KNOB \varnothing 30
9	SD102	LEVER
21	SD103	DUST BAG
32	SD104	FAN PULLEY \varnothing 30
33	SD105	FAN SHAFT
37	SD106	BALL BEARING 6005 VVCM
38	SD107	BEARING HOUSING
42	SD108	VENTILATOR WHEEL
53	SD109	SPACER
57	SD110	HANDLE
62	SD111	POLY V BELT 6J 965
63.1	SD112	SCREW DIN 931 M 8 x 35
63.2	SD113	CLAMP RING INA BR19
63.3	SD114	BALL BEARING 626 2RS

ref#	part #	desc
63.4	SD115	CONSTRAINER
63.5	SD116	SPACER
64	SD117	COVER (DRUM \varnothing 150mm)
66.1	SD118	SCREW DIN 963 M 4 x 8
66.2	SD119	COVER PROTECTOR
78.4	SD120	TIRE FOR WHEEL \varnothing 80
81	SD121	SPRING
90	SD122	COMPRESSION SPRING
92	SD123	WHEEL SHAFT
134	SD124	SANDING DRUM RUBBER
141	SD125	EXPANDABLE DRUM COMPLETE
145	SD126	CAPACITOR USA 100 MF
160	SD127	CIRCUIT BREAKER
121	SD128	DRUM RUBBER HANDY-8

The Powr-Flite Limited Warranty

The manufacturer warrants to the original purchaser that products manufactured are free from defects, provided such goods are installed, operated and maintained in accordance with written manuals or other instructions for a period of 1 year from date of purchase on workmanship, motor, and parts, switch, and yoke. In case you, as our customer, meet any trouble with your machine, contact a Powr-Flite representative, who will be happy to be of service to you and will take care of any warranty issues.

Powr-Flite[®]
COMMERCIAL FLOOR CARE EQUIPMENT

A Tacony Company

Ft. Worth, TX 76140

1-800-880-2193