

# CDS HYDRA-VAN

## Owners Manual

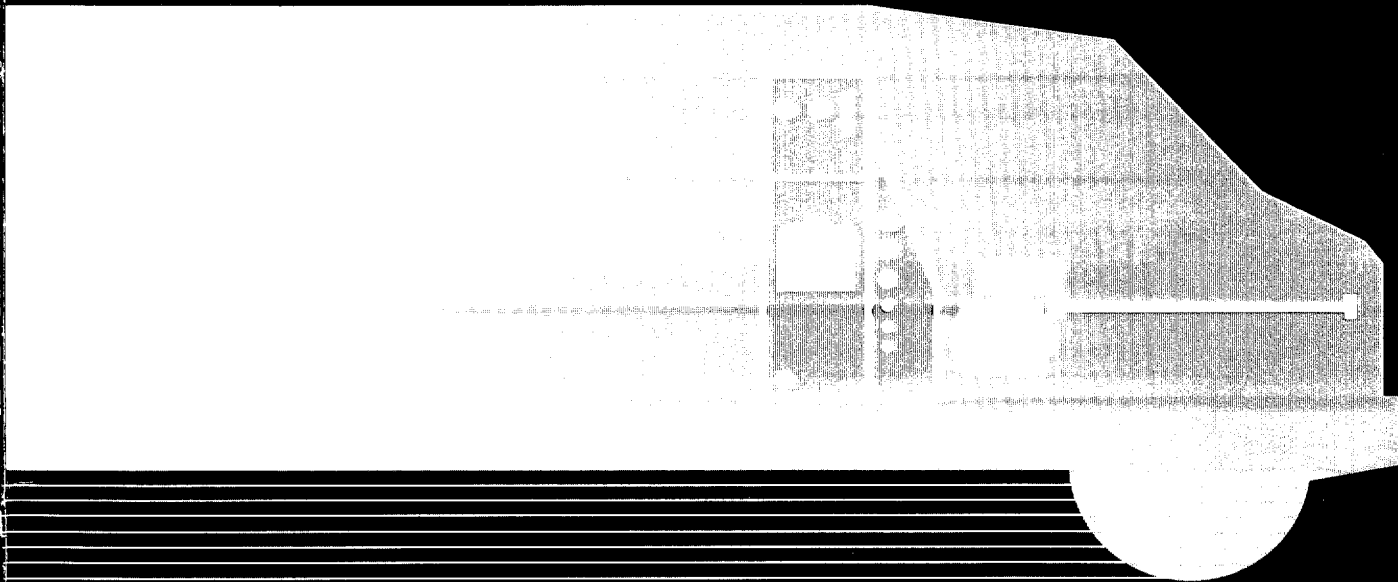

**HYDRAMASTER**  
Corporation

## HOW TO ORDER

To obtain a proper diagnosis of your malfunction, and to order warranty replacement parts, it is important that you proceed in the following manner:

1. Call HydraMaster Warranty/Service Dept. at (206) 775-7275.
2. Give the Warranty/Service Representative the following information:
  - A. Name of your company and your address.
  - B. Equipment Model (i.e. CDS).
  - C. Date of purchase.
  - D. Hours on the unit.
  - E. Serial number of unit.
  - F. Name of person authorized to order parts.
  - G. Salesman unit purchased from.
  - H. Description of malfunction.
  - I. Pressure readings on high pressure gauge with wand turned on and off.
3. If warranty replacement parts are needed, please specify method of shipment desired. **NOTE:** All replacement parts are sent freight collect, via:
  - A. U.P.S.
  - B. Air freight
  - C. Air mail
  - D. Air express
  - E. Auto Freight
4. Do not give malfunctioning parts to a HydraMaster Sales or Service Representative. **All parts must be returned directly to HydraMaster, freight prepaid.**

## ONE FINAL NOTE:

Any questions you have regarding the warranty program should be directed to the Warranty/Service Dept. Personnel at HydraMaster Corporation.

We shall always endeavor to be fair in our evaluation of your warranty claim, and shall provide you with a complete analysis of our findings.

## HydraMaster Warranty Policy

Effective April 1, 1987

HydraMaster warranty covers only defective materials and/or workmanship for the periods listed. Labor, and/or diagnostic reimbursement is specifically excluded.

### HOURS:

MONDAY THROUGH FRIDAY

7:00 am TO 6:00 pm

PACIFIC STANDARD TIME



PST

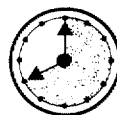

ROCK MT.



CENTRAL

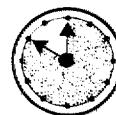

EASTERN

### TELEPHONE NUMBERS

GENERAL OFFICES:	(206) 775-7272
PARTS DEPT:	(206) 775-7276
SERVICE/WARRANTY:	(206) 775-7275
NEW EQUIPMENT SALES AND MARKETING:	1-800-426-1301

## Table of Contents

Parts Order .....	2	Service Kits Model 290 .....	22
Water Flow Diagram .....	2	Servicing the Valve Assemblies .....	23
Water and Chemical Flow Operation .....	3	Servicing the Pumping Section .....	24
Water Softener .....	3	Servicing Sleeves and Seals .....	25
Water Softener Hook-up Diagram .....	4	Servicing Crankcase Section .....	26
Jet Assembly .....	4	Cat Pump Trouble Shooting Guide .....	27
Wand Assembly .....	4	Electrical System .....	31
Valve Assembly .....	5	Electrical Diagram .....	32
Stem Assembly .....	5	Freeze Protection .....	33
Vacuum System Information .....	6	Cleaning and Chemical Precautions Information .....	33
Vacuum Flow Diagram .....	6	Cleaning Stroke Procedure/Over-Wetting .....	34
Vacuum Tank Filter Bags .....	7	Maintenance Procedure .....	35
Blower Lubricant .....	7	Overall Care of Unit .....	35
Vacuum Blower Warranty .....	8	Freeze Protection of Clutch Drive with Pump-In System .....	36
Factory Authorized Service		Maintenance Log .....	38, 39
Centers for Sutorbilt Products .....	9	Warranty Information .....	40
Lubrication (Vacuum Blower Motor) .....	10	Warranty Procedure .....	40
Filling Procedure (Vacuum Blower Motor) .....	10	HydraMaster Limited Warranty .....	Inside back cover
Vacuum Blower Trouble Shooting Guide .....	11		
Cat Pump Model 290, Operating			
Instructions & Specifications .....	13		
Cat Pump Warranty .....	14		
General Information for Cat Pump Repair .....	15		
Bypass Valve Illustration .....	15		
Chemical Proportioning and			
Level Control Illustration .....	16		
Chemical Tank Trouble Shooting .....	16		
Pump-In System Flow Diagram .....	18		
Cat Pump Dimensions .....	18		
Important Drive Information .....	19		
Specifications (pump) .....	19		
Piston Model 290 Exploded View .....	20		
Parts List Model 290 .....	20		

Machine Serial No. \_\_\_\_\_

© 1987 HydraMaster Corp.

## PARTS ORDERS

To expedite your parts needs, please call your sales representative. In most instances, he either stocks or has access to parts through a regional service center.

In the event parts are unavailable locally, contact the factory and coordinate your needs. If this becomes necessary, always indicate the method of shipment you desire, i.e. U.P.S., U.P.S. Blue Label, Air Freight, Air Express, etc.

HydraMaster Parts Dept. phone (206) 775-7276.

### REPLACEMENT PARTS

PART NO.	DESCRIPTION	QTY.
000-078-015	Flow Meter Kit	1
000-078-019	Wand Valve Plunger Kit	1
000-078-034	Pressure Bypass Valve Kit	1
000-076-005	Spray Jet 8006E	1
000-049-028	Recovery Tank Filter Bag	2
000-078-001	Cat 290 Short Cup Kit Standard	1
000-078-004	Cat 290 Hot Cup Kit (Optional)	1
000-049-023	Screen Garden Hose	6
000-052-050	440 Male Quick Connect	1
000-052-051	440 Female Quick Connect	1
000-052-052	660 Male Quick Connect	1
000-052-053	660 Female Quick Connect	1
000-010-019	Belt, Pump Drive. AX-26	1

## WATER FLOW DIAGRAM

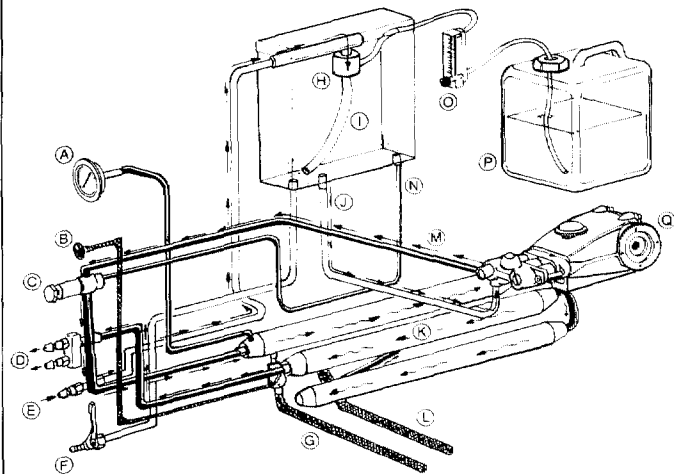

- |                                     |                        |
|-------------------------------------|------------------------|
| A. Pressure Gauge                   | J. Pump Intake         |
| B. Hot Water Shut-Off Valve Control | K. Heat Exchangers     |
| C. Bypass Valve                     | L. Radiator Water (In) |
| D. High Pressure Solution Outlet    | M. Pump Output         |
| E. Incoming Water                   | N. Bypass Return       |
| F. Drain                            | O. Chemical Flow Meter |
| G. Radiator Water (Out)             | P. Chemical Jug        |
| H. Proportioner                     | Q. High Pressure Pump  |
| I. Chemical Mix Tank                |                        |

## **WATER AND CHEMICAL FLOW OPERATION**

This system has been designed to be the most simple and trouble-free ever.

The incoming water flows directly to the mix tank. Water will now flow through a proportioning valve which will simultaneously mix the chemical to achieve your desired solution. The mix tank is equipped with 2 different float valves, one of which responds to the water level of the tank and will maintain the proper volume of solution to be reserved for the cat pump. The secondary float valve is a safety valve that is designed to protect your system from sudden or unexpected loss of water supply. If, for example, the water source at the house was turned off, the water level of the mix tank would drop, activating the secondary valve which automatically disengages the electric pump clutch.

In conjunction with the incoming flow, the chemical ratio may be obtained by an adjustment of the chemical flow meter during the fill cycle of the mix tank. The chemical will flow from the chemical jug to the chemical flow meter, then to the proportioner where it is distributed into the mix tank at your desired proportion. This line should be flushed with vinegar weekly to prevent abnormal chemical build-up. This may be done by removing the clear plastic hose from the chemical jug and inserting it into a one quart container of vinegar. This should be done with the chemical flow meter setting on 10 GPH with heater "off". Simply spray the wand for the duration of the vinegar in the one quart container, then repeat the process with clear water to void all lines of vinegar.

**NOTE:** With this unique chemical system, your chemical flow is *proportioned to the filling cycles of the mix tank, not the direct spraying of the wand.* Therefore, it is possible that as your wand is spraying, you may have no chemical flow. Also, the converse is true in that you may not be spraying your wand but, if the mix tank

is in a filling cycle your chemical flow meter may read your desired flow.

This chemical system will mix a 1 to 30 ratio when flow meter is set at 5 GPH. Most chemical suppliers will recommend a 1 to 15 ratio therefore you can either set the flow meter at 10 GPH, giving you a 1 to 15 ratio of chemical to cleaning water, or double the recommended strength of chemical in the 5 gallon jug and set the flow meter at 5 GPH, thereby attaining a 1 to 15 ratio. (It is recommended that you set the flow meter at 10 GPH for overall best results.)

The water will now be siphoned from the bottom of the mix tank to the Cat Pump. If the wand is not spraying, the water will bypass from the bottom of the brass pressure relief valve to the mix tank.

## **WATER SOFTENER**

Many areas of the country have an excess of minerals in the water which results in what is commonly called "hard water". These minerals tend to adhere to the insides of heater coils and other parts of the machines causing damage and a loss of cleaning effectiveness.

Reports from several of our machine users commending the results of the use of water softeners in conjunction with their *machines prompts us to recommend the procedure to everyone in a "hard water" area.*

The relatively low cost of a water softener service is more than made up for in the increased life of machine parts and continued cleaning efficiency. The water softener will also increase the effectiveness of the cleaning chemical being used, therefore, less chemical will be needed.

*(continued next page)*

(Softener, continued)

Contact a water softener distributor in your area for information on the rental of a simple water treatment unit to carry in your truck. Be sure to change the water softener in accordance with the capability of the softener. Example: If the softener will treat 900 gallons of water and the machine uses an average of 30 gallons per hour of use on an average of 5 hours a day would be 150 gallons a day would be treated. Five days would equal 750 gallons of water, therefore, the softener would be changed every 6 working days for maximum softening.

### WATER SOFTENER HOOK-UP

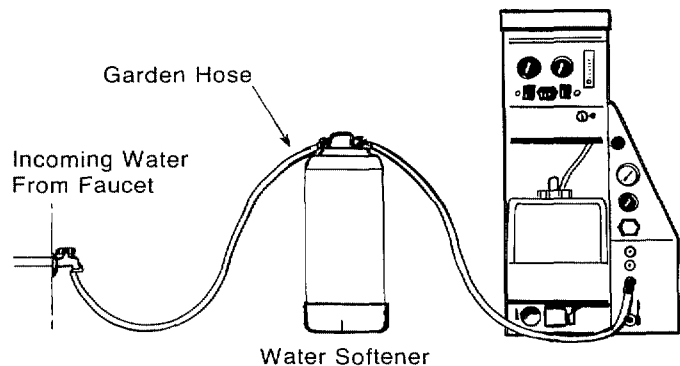

### JET ASSEMBLY

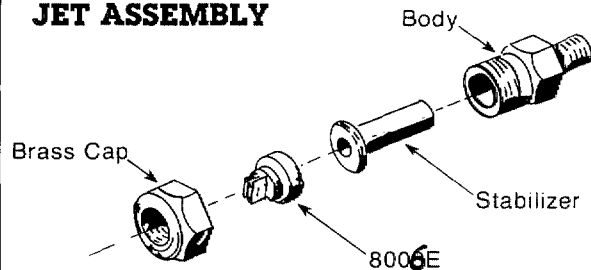

### WAND ASSEMBLY

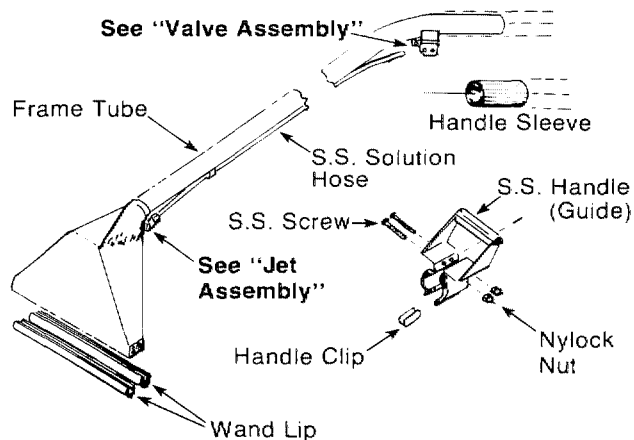

## VALVE ASSEMBLY

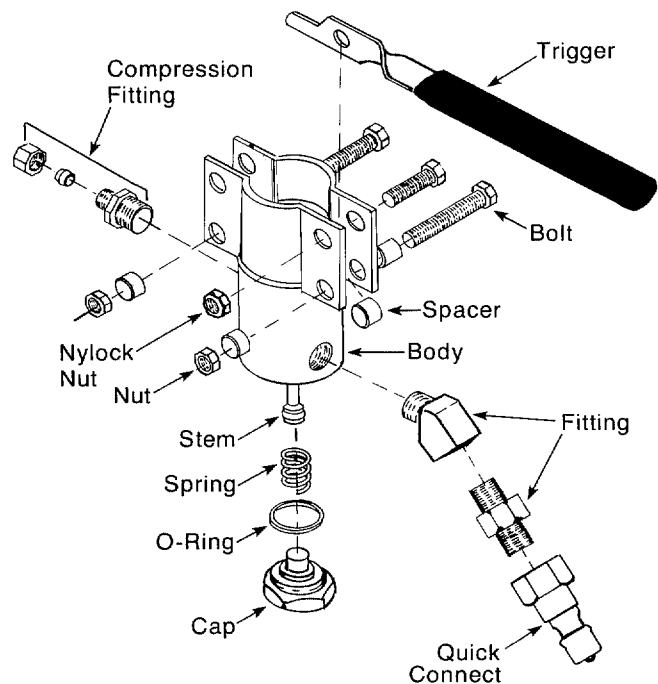

## STEM ASSEMBLY

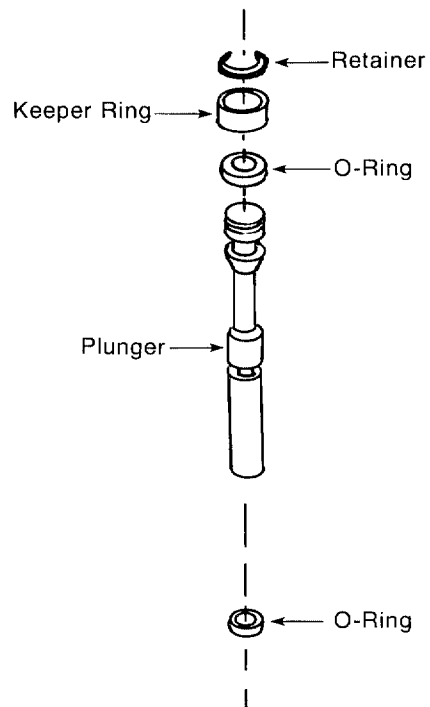

## VACUUM SYSTEM INFORMATION

The vacuum blower incorporated in this machine is a positive displacement lobe type, manufactured by Fuller Company. The performance and life of this unit is greatly dependent on the care and proper maintenance it receives.

Because of the close tolerances between the lobes and housing of the vacuum blower, solid objects entering the inlet will damage the internal lobes, gears and bearing or direct drive coupler.

To prevent this, a stainless steel filter screen has been placed at the vacuum inlet inside the vacuum recovery tank. This stainless steel screen is finger tight and should be removed weekly for cleaning.

**Caution** should be used when machine is being run for test purpose and the vacuum inlet on top of machine is open.

To protect the vacuum blower from overloading and damaging itself, there is a vacuum relief system installed on the vac tank. When the vacuum tank inlet is completely sealed off, a maximum of 12 HG will be attained. A blower lube port is located above the vacuum gauge; at the end of each day, LPS 1 or WD-40 is sprayed in before shutting down the machine. See blower lubrication illustration. If you fail to lubricate the vacuum blower daily, rust deposits and moisture will decrease the life of the vacuum blower.

**Caution:** Foam passing through the blower could lead to serious problems, therefore, it is important to keep the vacuum tank foam free.

## VACUUM FLOW DIAGRAM

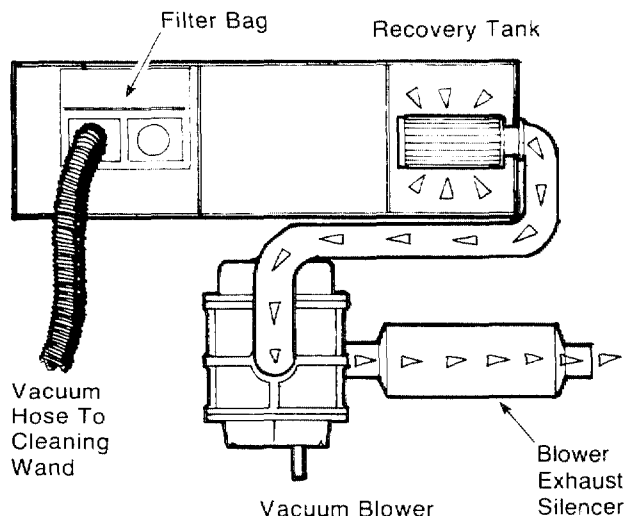



## VACUUM TANK FILTER BAGS

HydraMaster filter bags are designed to trap most of the lint, sand and dirt that would normally collect at the bottom of your vacuum tank. The use of these bags, if emptied at the end of each job, will eliminate the build-up of much of the debris in the tank and avoid a mess. The drawstring top of these bags is designed to be tied to the incoming dirty water inlet in the vacuum tank.

To re-order bags use part number 049-029.

### VACUUM TANK FILTER BAGS

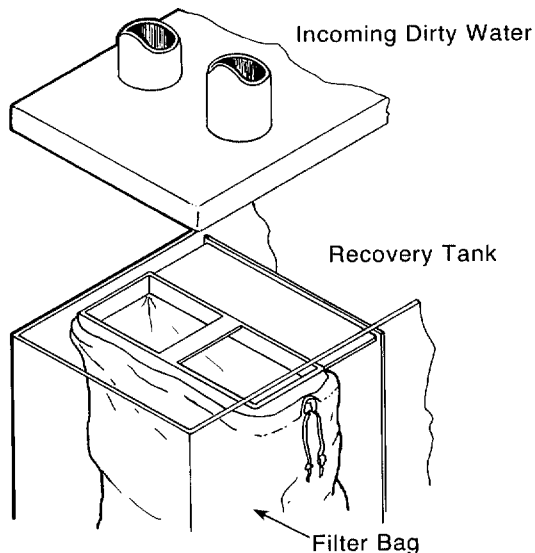

## BLOWER LUBRICANT

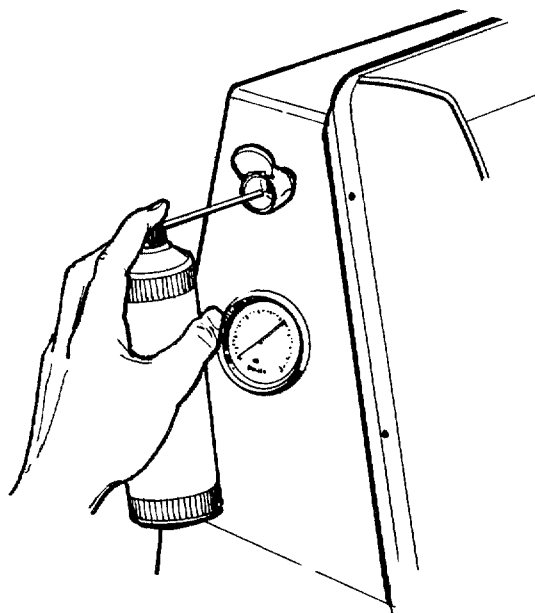

Spray lubricant into blower lube port for 3 to 5 seconds, then immediately shut off machine.

Use only LPS 1 or WD-40 moisture displacing lubricants.

## VACUUM BLOWER WARRANTY

FULLER warrants products of its manufacture to be free from defects in material and workmanship if properly installed, maintained, and operated under normal conditions with competent supervision.

No person, agent, representative or dealer is authorized to give any warranties on behalf of FULLER nor to assume for FULLER any other liability in connection with any of FULLER'S products.

This warranty shall extend for one (1) year from date of installation provided this equipment has been put into service within six months after shipment from the FULLER factory. If repairs or replacements are made by the Purchaser without FULLER'S prior written consent, FULLER'S warranty shall cease to be in effect. No allowance will be granted for any repairs or alterations made by the Purchaser without FULLER'S prior written consent.

Machinery, equipment and accessories furnished by FULLER, but manufactured by others, are warranted only to the extent of the original manufacturer's warranty to FULLER.

FULLER agrees at its option to repair at the point of shipment or to replace without charge f.o.b. point of shipment, any part or parts of products of FULLER'S manufacture, which within the specified warranty period shall be proved to FULLER'S satisfaction to have been defective when shipped, provided the Purchaser promptly notifies FULLER, in writing, of such alleged defect.

FULLER'S liability to Purchaser, whether in contract or in tort arising out of warranties, representations, instructions, or defects from any cause shall be limited to repairing or replacing of the defective part or parts as aforesaid, f.o.b. point of shipment.

No liability whatsoever shall attach to FULLER until said products have been paid for.

EXCEPT AS STATED IN THIS SECTION AND IN THE PRECEDING SECTION TITLED "WARRANTY" AND EXCEPT AS TO TITLE, THERE ARE NO GUARANTEES OR WARRANTIES OF MERCHANTABILITY, FITNESS, PERFORMANCE OR OTHERWISE, EXPRESS, IMPLIED OR STATUTORY, AND FULLER SHALL HAVE NO LIABILITY FOR CONSEQUENTIAL, INCIDENTAL OR OTHER DAMAGES, HOWSOEVER CAUSED.

Date installed \_\_\_\_\_

Model \_\_\_\_\_

Serial # \_\_\_\_\_

**FULLER COMPANY**  
2966 East Victoria Street  
Compton, California 90224

## **FACTORY AUTHORIZED SERVICE CENTERS FOR SUTORBILT PRODUCTS**

**FULLER COMPANY / COMPTON DIVISION**  
2966 E. Victoria St., Compton, CA 90224  
213/636-9821 or 639-7600

**FULLER COMPANY / MANHEIM DIVISION**  
236 South Cherry Street  
Manheim, Pennsylvania 17545  
717/665-2224

**BAYLISS MACHINE & WELDING CO.**  
2901 8th Avenue North  
Birmingham, Alabama 35203  
205/323-6121

**BARNEY'S PUMPS INC.**  
3907 Highway 98 South  
Lakeland, Florida 33802  
813/686-8195

**ASSOCIATED TECHNICAL SERVICE, INC.**  
1229 Waimanu Street #21  
Honolulu, Hawaii 96814  
808/537-1206

**WM. W. MEYER & SONS**  
8261 Elmwood Avenue  
Skokie, Illinois 60076  
312/673-0312

**OLIVER & LAUGHTER EQUIPMENT CO.**  
10450 Westoffice  
Houston, Texas 77042  
713/977-2577

**GREGORY-SALISBURY & CO.**  
805 South Front Street  
New Orleans, Louisiana 70130  
504/524-5207

**SCHWARZ FOUNDRY COMPANY**  
2001 West Fort Street  
Detroit, Michigan 48216  
313/496-1880

**CAROTEK INCORPORATED**  
640 Sam Newell Road  
Mathews, N. Carolina 28105  
704/847-4406

**DYNMAC CORPORATION**  
7925 E. 40th Street  
Tulsa, Oklahoma 74145  
918/627-0110

**ELECTRIC CRAFTS LTD.**  
3936 Edmonton Trail N.E.  
Calgary, Alberta T2E 3P6  
403/276-9676

**PUMPS & POWER LTD.**  
1380 Napier Street  
Vancouver, B.C., Canada  
604/255-4341

**GATX-FULLER LTD.**  
721 Progress Avenue  
Scarborough, Ontario, Canada  
416/438-6540



## **FULLER COMPANY**

A GATX COMPANY  
2966 East Victoria Street  
Post Office Box 4308, Compton, California 90224  
Tel: (213) 639-7600 (213) 636-9821 Telex: 67-4607

## LUBRICATION

At the gear end the timing gear teeth are lubricated by being partially submerged. The gear teeth serve as oil slingers for gear end bearings. At the drive end the bearings are grease lubricated.

## FILLING PROCEDURE

Remove square head vented oil fill plug (A) on gear end. Remove oil level plug (B) located in the head plate. Fill gear case until oil drips out of the oil level hole (B).

Use lubricants as listed.

Add fresh oil as required to maintain proper level. The oil should be drained, flushed and replaced every 1500 hours or more frequently if inspection so indicates. The oil drain plug is at (C).

**NOTE:** Older units may have the oil fill level and drain holes located in the cast iron gear case instead of in the head plate.

Bearings on drive end of blower require grease lubrication every 100 hours of operation. Bearings which require grease lubrication will have a grease fitting (D) at each bearing. When regreasing, the old grease will be forced out of the vents during operation. To prevent damage to seals, these vents must be kept open at all times.

### LUBRICATION INSTRUCTIONS FOR OIL LUBRICATED GEARS AND BEARINGS

Add fresh oil as required to maintain proper level. Drain and refill every 1500 hours of operation under normal service, more frequently when required. Use a good quality oil.

BLOWER DISCHARGE TEMPERATURE	OIL GRADE U.S.A.*	OIL VISCOSITY CENTISTOKES @ 40°C
-40° to 32° F (-40° to 0° C)	SAE 10W	45
32° to 100° F (0° to 38° C)	SAE 20	100
100° to 275° F (38° to 135° C)	SAE 40	200
over 275° F (135° C)	SAE 50	250

\*In applications with extreme variations in ambient temperature a 20W-50W multiple viscosity oil is recommended.

### FOR GREASE LUBRICATED BEARINGS

Service every 500 hours of operation

BLOWER DISCHARGE TEMPERATURE	TYPE GREASE
-40° to 275° F (-40° to 120° C)	No. 2 Bearing Grease

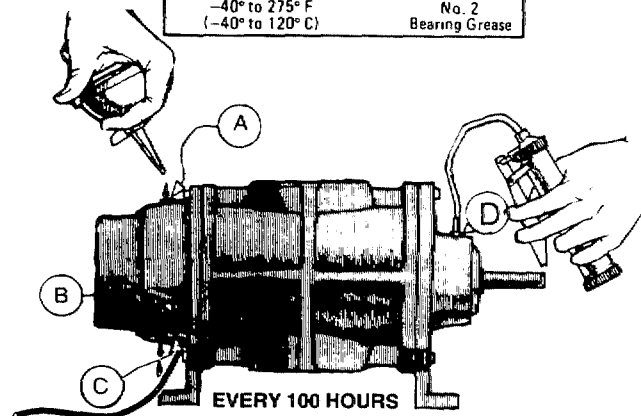

# VACUUM BLOWER TROUBLE SHOOTING GUIDE

## PROBLEM: Loss of Vacuum

Cause	Solution
Collapsed vacuum hose between blower and vacuum tank.	Remove and replace hose. NOTE: A special reinforced hose is required for replacement.
Clogged stainless steel filter.	Remove and clean or replace stainless steel filter.
Defective vacuum tank seal.	Remove and replace vacuum tank seal.
Defective or 'open' vacuum tank dump valve.	Close valve. Replace valve.
Fractured weld on vacuum tank.	Re-weld as required or replace tank.
Collapsed or kinked vacuum hose.	Reshape hose if possible and/or eliminate kinks.
Plugged vacuum hose.	Remove obstruction by reversing the vacuum hose.
Restriction in cleaning tool.	Remove obstruction.
Worn end plates or lobes in vacuum blower.	Replace worn components. NOTE: Must be accomplished by a qualified technician.
Loose drive shaft between clutch and blower.	The set screws may come loose causing blower to stand still while engine may be turning properly. NOTE: Unless the blower is seized or making a knocking noise, your vacuum loss is not caused by a bad blower.

## PROBLEM: Blower is Seized

Cause	Solution
Rust.	Spray rust dissolving lubricant onto lobes to emulsify rust and attempt to rotate vacuum lobes.
Foreign matter.	Disassemble and remove foreign matter and repair as required. NOTE: Disassembly must be accomplished by qualified technician.

NOTE: The above mentioned, rust, foreign matter and seizing are often caused from foam traveling through the blower.

*(continued next page)*

## VACUUM BLOWER TROUBLE SHOOTING GUIDE (continued)

### PROBLEM: Noise in Vacuum Blower

Cause	Solution
Loose Direct Drive Coupler.	Examine universal shaft for defects and retighten lock bolts. Replace universal shaft.
Worn Gears.	Remove and replace gears. NOTE: Replacement of gears must be accomplished by a qualified technician. Timing of vacuum blower has been changed due to worn components. Replacement of components must be accomplished by a qualified technician.
Lack of Lubrication. NOTE: Permanent damage may have resulted from lack of lubrication.	Lubricate as specified. See index.
Worn bearings.	Remove and replace bearings as required. Must be accomplished by qualified technician.
Debris and/or foreign material build-up. NOTE: A stainless steel filter is provided at vacuum inlet located in vacuum tank.	Disassemble vacuum blower and remove foreign material. NOTE: Disassembly should be accomplished by qualified technician only. Replacement of worn parts is recommended if this procedure is necessary.
Loose or missing mounting bolts.	Tighten or reinstall mounting bolts.



## CAT PUMPS Model 290

### OPERATING INSTRUCTIONS

**CAUTION:** CAT PUMPS are positive displacement pumps. Therefore, a properly designed pressure relief mechanism **MUST** be installed in the discharge piping. Failure to install such relief mechanism could result in personal injury or damage to the pump or system. Cat Pumps Corporation does not assume any liability or responsibility for the operation of a customer's high pressure system.

### SPECIFICATIONS

Volume: 3.5 GPM (13 L/M)  
 Discharge Pressure: 1200 PSI (83 BAR)  
 Maximum Inlet Pressure: -8.5 to + 40 PSI (-0.6 to + 2.8 BAR)  
 RPM: 1200 RPM (1200 RPM)  
 Bore: 0.787" (20 mm)  
 Stroke: 0.472" (12 mm)  
 Crankcase Capacity: 10 oz. (.3 L)  
 Maximum Fluid Temperature 160°F (71°C)  
 Inlet Ports (1): 1/2" NPT (1/2" NPT)  
     Chemical Injection Port (1): 1/4" NPT (1/4" NPT)  
 Discharge Ports (2): 3/8" NPT (3/8" NPT)  
     (1): 1/2" NPT (1/2" NPT)  
 Pulley Mounting: Either side (Either side)  
 Shaft Diameter: 0.650" (16.5 mm)  
 Weight: 12.1 lbs. (5.5 kg)  
 Dimensions: 10.77"x9.06"x5.14" (273.5x230x130.5 mm)

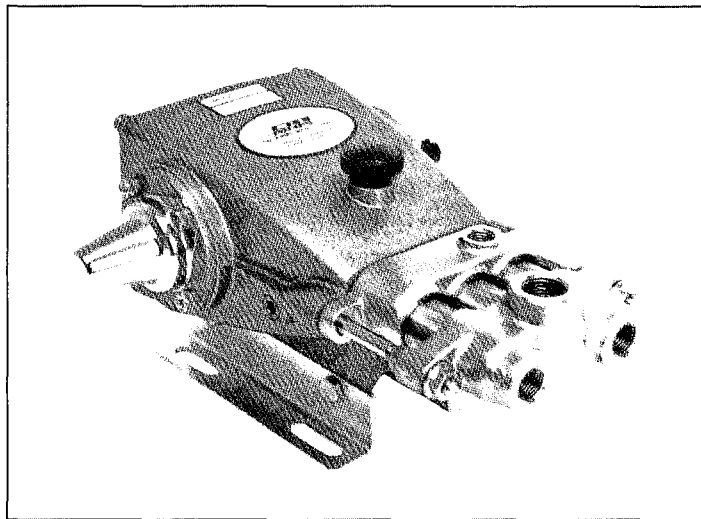

Products described hereon are covered by one or more of the following U.S. patents: 3558244, 3652188, 3809508, 3920356, and 3930756



P.O. Box 885 MINNEAPOLIS, MN 55440  
 Phone (612) 780-5440 — Telex 29-0276

• N.V. CAT PUMPS INTERNATIONAL S.A. •  
 Harmoniestraat 29  
 B 2000 Antwerp, Belgium  
 Phone (03) 237-72-24 — Telex 33947

• CAT PUMPS — A.G. •  
 Loretochöche 5  
 CH-6300 ZUG, Switzerland  
 Phone (42) 21-31-40 — Telex 865 160 cpag ch

• CAT PUMPS DEUTSCHLAND GmbH •  
 Rostocker Strasse 9  
 6200 Wiesbaden-Bierstadt, West Germany  
 Phone 0612-56 00 01/2 — Telex 41 86713

• CAT PUMPS (U.K.) LTD. •  
 27 Station Industrial Estate, Fleet  
 Hampshire GU13 8QY, England  
 Phone Fleet 22031 — Telex 858898

## CAT PUMP WARRANTY

This Cat Pump ("product") is warranted by the manufacturer to be free from defects in workmanship and material for one year from date of manufacturer's shipment. This warranty is limited to repairing or replacing products which manufacturer's investigation shows were defective at the time of shipment by the manufacturer. All products subject to this warranty shall be returned F.O.B. Cat Pumps Corp., Minneapolis, Minnesota 55430, U.S.A. for examination, repair or replacement.

The express warranty set forth herein is in lieu of all other warranties, express or implied, including without limitation any warranties of merchantability or fitness for a particular purpose and all such warranties are hereby disclaimed and excluded by the manufacturer. Repair or replacement of defective products as provided above is the sole and exclusive remedy provided hereunder and the manufacturer shall not be liable for any further loss, damages or expenses, including incidental or consequential damages, directly or indirectly arising from the sale or use of this product.

This warranty is subject to the following warranty conditions:

**Important Conditions:**

LUBRICATION - fill crankcase to the top of oil gauge window per specifications with Cat Pump oil or equivalent SAE 40

weight hydraulic oil with antiwear and rust inhibitor additives. Change initial fill after 50 hour run-in period. Change oil every three months or at 500 hour intervals thereafter. Prrrrm-a-lube seals need no lubrication. Blue dot seals and wicks must receive three drops of Cat Pump oil per wick every 50 hours of operation.

GOOD LUBRICATION IS THE EASIEST, MOST EFFICIENT AND LEAST EXPENSIVE OF PREVENTATIVE MAINTENANCE.

RPM and PRESSURE - Pump operation must be within RPM and pressure specifications. Pressure relief valve must be installed.

DO NOT PUMP ACIDS OR ABRASIVE FLUIDS with this unit. Consult Cat Pumps for additional information on questionable fluids.

FREEZING CONDITIONS - Pump must be protected from freezing conditions.

USE OF OTHER THAN CAT PUMP PARTS OR THEIR EQUIVALENT VOIDS THE WARRANTY



## GENERAL INFORMATION FOR CAT PUMP REPAIR

As you remove your discharge manifold, there is a set of 3 check valves (which usually fall out during dis-assembly). If the surfaces of these check valves are dirty, or show signs of chemical build-up, it is probable that they would remain open causing pressure loss or pulsation. Upon inspecting the valves, make sure that the teflon buttons in the valve spring retainers are still intact. Also examine the discharge manifold. Look for problems such as cracks, chemical buildup or warpage due to freezing. If this discharge manifold is warped, it will cause the check valves to stick and will result in loss of pressure.

The Cat pump cups are often the source of pressure loss. Upon inspection they may appear melted or torn, but often they will look good. Replace them anyway. There is no sure method of visually inspecting the cups. HydraMaster recommends changing cups whether they look good or not.

Anytime your pump is being dismantled, HydraMaster recommends replacement of all 'o' rings and seals. This is merely a convenience to the customer to make sure that the Cat pump is in top operating condition.

The prrm-a-lube seals located within the intake manifold will allow air to enter the pump if they are worn. Again, it is difficult to visually pinpoint a defective prrrm-a-lube seal. Replace them all.

Within the piston sleeve cylinders there are 6 'o' rings that are about ¼ the size of a penny. If these 'o' rings are bad, water will be pumped back into the oil. If this has occurred the oil will raise in level and appear milky. If you are unable to repair seals right away, change oil frequently. Repair the pump as soon as possible so as to not damage bearing or connecting rods.

Repairing of Cat pumps is not a difficult task. However, before disassembling make sure you have the proper parts required.

- 1 - short (or hot) cup kit
- 3 - Prrrm-a-lube seals
- 6 - piston sleeve 'o' rings
- 1 - bottle Cat oil

Read instructions thoroughly prior to disassembly and follow directions as stated. Oil all seals thoroughly prior to installation. (Remember, a newly scarred seal is no better than one you just took out.)

## BYPASS VALVE ILLUSTRATION

To service bypass valve

- Unscrew hex knob and remove.
- Wiggle protruding shaft with fingers or pliers, pull up and remove from main body.

Special instructions - bypass valve

- #4 - 5/16" fine thread
- #6 - Cup seal (if leather, replace or lube with leather oil).
- #7 - Brass bushing
- #8 - Shaft - if cup needs replacement, place thin end of shaft only in vise and remove 5/16" nut. Fat end is "seating" surface and must be free of abrasion to properly seat. NOTE: IMPORTANT - when replacing seals, only wrench nut #4 to where cup will not turn on shaft. If cup is too loose, bypass will leak. Too tight, cup will flange and bypass will leak.

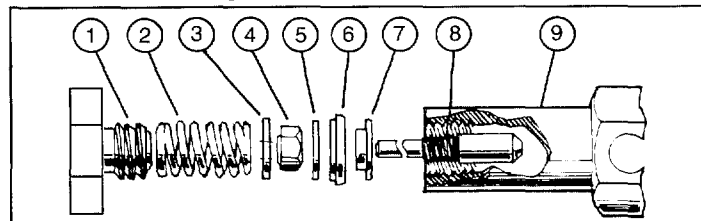

## CHEMICAL PROPORTIONING AND LEVEL CONTROL ILLUSTRATION

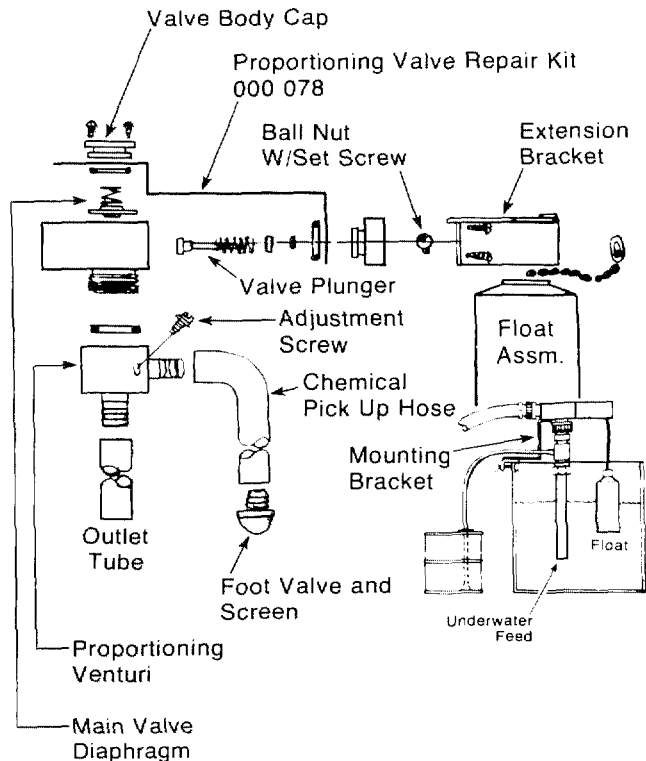

## CHEMICAL TANK TROUBLE SHOOTING

**PROBLEM:** No or Low Chemical Flow

### Solution

Check that hoses in the tank are secured. Check that the hose from the top of the flow meter to the side of the mix tank is secured with no kinks. Check the hose from the bottom of the flow meter to the chemical jug for kinks or cracks.

Check the foot valve and screen on the end of the hose which goes into the mix tank. To check this screen for proper function, remove it from the plastic hose. You should be able to suck through the hose barb end, but you should not be able to blow through the hose barb end. (If you can not suck through it then rinse it out with vinegar.) When screen is removed the chemical fill hose should be lifted into a vertical position so the ball in the foot valve will seat by gravity. (This is only a temporary fix for low water pressure areas.)

Check flow meter for float obstruction.

Check to insure that the adjusting screw on proportioning venturi is backed out.

Is proportioning venturi closed? Soak in warm water or vinegar solution.

Is incoming water pressure less than 20 PSI?

Cracked or defective chemical flow meter?

**NOTE:** If you are in a low water pressure area and find that the volume of water entering the mix tank is not enough to allow your venturi to siphon chemical, unscrew the spring from the foot valve screen and remove the spring.

---

**PROBLEM: Inability to Adjust Chemical with the Flow Meter**

---

**Solution**

---

Debris lodged behind teflon seat in flow meter knob.

Teflon seat dismounting from flow meter knob.

---

---

**PROBLEM: Solution Reversing from Mix Tank to Chemical Jug**

---

**Solution**

---

Anti-siphon screen removed from chemical jug hose.

Debris in anti-siphon screen.

---

---

**PROBLEM: Mix Tank Overflows**

---

**Solution**

---

Float ball in mix tank hanging up (not moving freely).

Extension bracket pinching the float lever, restricting full action of the lever.

Plunger not seating properly on the valve. (Remove the 2 screws which hold the extension assembly to the valve. Do not lose or drop the screws. Remove the extension assembly. Turn it upside down. Inspect the plunger for proper seating. If there is no debris obstructing the valve or plunger, the plunger may be out of adjustment. To adjust, loosen the set screw on the ball nut and move the ball toward the end of the rod 1/16". Retighten set screw. Place extension assembly back into position. Tighten the two screws.

---

---

**PROBLEM: Mix Tank Doesn't Keep Up With Water Output**

---

**Solution**

---

Check garden hose quick connect assembly screen.

Check garden hose and/or feed hose to the mix tank for clog, kinks or blockage.

Float ball in mix tank hanging up. (Not moving freely.)

Extension bracket pinching float lever, restricting full action of lever.

Valve plunger not opening fully. To adjust, remove the 2 screws which hold the extension assembly to the valve. (Do not lose or drop the screws.) Remove the extension assembly, turn it up side down. To adjust, loosen the set screw on the ball nut. Place your thumb on the plunger and press it in 1/16" and slide the ball nut w/set screw toward the plunger end 1/16". Tighten the set screw. Place the extension assembly back into position. If the tank starts to overflow, the ball nut is too close to the valve plunger and should be moved back away from the valve plunger slightly.

---

---

**PROBLEM: Pump Pulsates When The Tank Is in a Fill Mode**

---

**Solution**

---

Check that the hose which goes from the gray plastic venturi to the bottom of the tank is not directed toward the Cat pump pick up port. If it is, aim it in another direction.

---



## IMPORTANT DRIVE INFORMATION

Pump speed and pump output in gallons per minute as tabulated is based upon a 1725 RPM drive motor. Select motor pulley size and provide GPM of the approximate pump output desired.

Pump RPM and GPM output are approximate values due to variations in pulleys, belts and motors between manufacturers and a  $\pm 5\%$  pump output tolerance.

Horsepower figures shown are brake horsepower figures. For gas engine requirements, follow engine manufacturer's recommendations. In general, use a gas engine with approximately double to electric motor horsepower.

HORSEPOWER REQUIREMENTS						
Flow		PRESSURE			MOTOR PULLEY SIZE Using 1725 RPM Motor & Std. Pump Pulley O.D.	
		PSI 800	PSI 1000	PSI 1200		
GPM	L/M	BAR 55	BAR 70	BAR 85	RPM	Pulley O.D.
3.5	13	1.9	2.4	2.9	1200	3.5
3.0	11	1.7	2.1	2.5	1029	3.0
2.5	9	1.4	1.7	2.1	858	2.5
<b>DETERMINING THE PUMP R.P.M.</b>		$\frac{\text{Rated G.P.M.}}{\text{Rated R.P.M.}}$			$= \frac{\text{"Desired" G.P.M.}}{\text{"Desired" R.P.M.}}$	
<b>DETERMINING THE REQUIRED H.P.</b>		$\frac{\text{GPM} \times \text{PSI}}{1460}$			$= \frac{\text{Electric Brake H.P. Required}}$	
<b>DETERMINING MOTOR PULLEY SIZE</b>		$\frac{\text{Motor Pulley O.D.}}{\text{Pump R.P.M.}}$			$= \frac{\text{Pump Pulley O.D.}}{\text{Motor R.P.M.}}$	

Note: Consult engine manufacturer when using gas or diesel engine

## SPECIFICATIONS

	U.S. Measure	Metric Measure
Volume	3.5 G.P.M.	(13 L/M)
Discharge Pressure	1200 P.S.I.	(85 BAR)
Max. Inlet Pressure	-8.5 to 40 P.S.I.	(-0.6 to + 2.8 BAR)
RPM	1200 RPM	(1200 RPM)
Bore	0.787"	(20 mm)
Stroke	0.472"	(12 mm)
Crankcase Capacity	10 oz.	(.3 L)
Maximum Fluid Temperature	160°F	(71°C)
Inlet Ports (1)	1/2" NPT	(1/2" NPT)
Discharge Ports (2)	3/8" NPT	(3/8" NPT)
Pulley Mounting	Either side	(Either side)
Shaft Diameter	0.650"	(16.5 mm)
Weight	12.1 lbs.	(5.5 kg)
Dimensions	10.77" x 9.06" x 5.14"	(273.5x230x130.5mm)

# PISTON MODEL 290 Exploded View

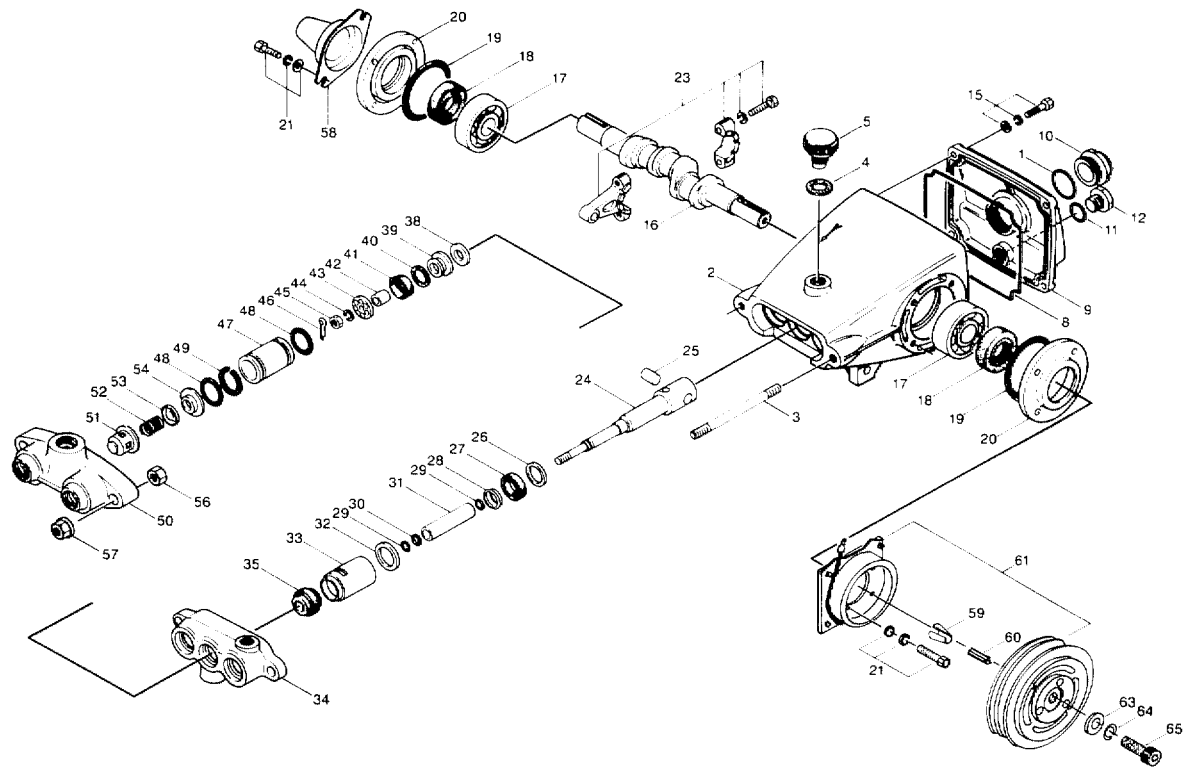

# PARTS LIST Model 290

ITEM	PART NO.	DESCRIPTION	QTY.
1	20285	O-Ring (Buna-N)	1
2	44274	Crankcase	1
3	85680	Stud (M8 x 82)	2
4	44377	O-Ring, Oil Filler Cap	1
5	44374	Oil Filler Cap	1
8	43340	O-Ring, Crankcase Cover	1
9	43339	Crankcase Cover	1
10	43987	Bubble Oil Gauge	1
11	23170	O-Ring, Drain Plug	1
12	25625	Drain Plug	1
15	92520	Sems Comb Head Screw (M6 x 20)	6
16	43804	Crankshaft	1
17	14487	Rearing	2
18	24159	Oil Seal (Buna-N)	2
19	26536	O-Ring, Oil Seal Case	2
20	27950	Oil Seal Case	2
21	92519	Sems Comb, Head Screw (M6 x 16)	8
23	101799	Connecting Rod	3
24	101800	Piston Rod	3
25	16948	Piston Pin	3
26	20017	Seal Washer	3
27	25301	Oil Seal	3
28	25327	Barrier Slinger	3
29	25392	O-Ring, Sleeve	3
	28771	O-Ring, Sleeve (Viton)	3
30	29003	Back-Up Ring, Sleeve (Teflon)	3
31	29614	Sleeve (29743 Unchromed)	3
32	26854	Seal Washer	3
33	28597	Seal Retainer	3
34	25128	Inlet Manifold	1
	25635	Inlet Manifold-Stainless Steel	1

ITEM	PART NO.	DESCRIPTION	QTY.
35	30315	Prrrrm-A-Lube Seal	3
	30325	Prrrrm-A-Lube Seal (Viton)	3
38	27004	Inlet Valve	3
39	30543	Bac-Cup Piston	3
40	30544	Bac-Cup Ring (Teflon)	3
41	43172	Cup (Viton)	3
	43474	Bac-Cup Assembly	3
42	27983	Piston Spacer	3
43	27002	Piston Retainer	3
44	27006	Conical Washer-SS (M6)	3
45	27000	Nut-SS (M6)	3
46	14158	Cotterpin	3
47	101802	Cylinder (43834 Unch)	3
48	23172	O-Ring, Cylinder (Buna-N)	6
	11377	O-Ring, Cylinder (Viton)	6
49	21985	Bac-Up Ring, Cylinder	3
50	24459	Discharge Manifold	1
	25634	Discharge Manifold-S.S.	1
51	43442	Valve Spring Retainer	3
52	43360	Valve Spring	3
53	43723	Valve	3
54	43434	Discharge Valve Seat	3
56	81109	Hex Nut (M8)	2
57	101804	Hex Flange Nut (M8)	2
58	25130	Shaft Protector	1
<b>Electric Clutch Assembly</b>			
59	152-005	Tapered Sleeve	1
60	077-005	Key, Electric Clutch	1
61	036-005	6" Electric Clutch	1
62	143-084	8-30 mm Socket Head Screw	1
63	174-004	Flat Washer (5/16 US)	1
64	174-018	Lock Washer (5/16 US)	1

## SERVICE KITS

### 30023 Cup Kit

- 3 Cup
- 6 O-Ring, Cylinder
- 3 Cotterpin
- 1 Instruction Sheet
- 1 Cup Inserter

### 30305 Seal Kit

- 3 Prrrrm-A-Lube Seal
- 3 Cotterpin
- 2 Abrasive Paper
- 1 Instruction Sheet

### 30431 Sleeve and Seal Kit

- 3 Prrrrm-A-Lube Seal
- 3 Barrier Slinger
- 3 Cotterpin
- 3 Sleeve
- 6 O-Ring, Sleeve
- 1 Instruction Sheet

### 30686 Valve Kit

- 3 Valve Spring Retainer
- 3 Valve Spring
- 3 Valve
- 3 Valve Seat
- 3 O-Ring, Cylinder
- 1 Instruction Sheet

### 30860 Piston Kit

- 6 O-Ring, Cylinder
- 3 Back-Up Ring, Cylinder
- 3 Bac-Cup Piston
- 3 Bac-Cup Ring
- 3 Cup
- 3 Piston Spacer
- 3 Piston Retainer
- 3 Conical Washer (M6)
- 3 Nut (M6)
- 3 Cotterpin
- 3 Inlet Valves
- 1 Instruction Sheet

## PUMPING SECTION CUTAWAY

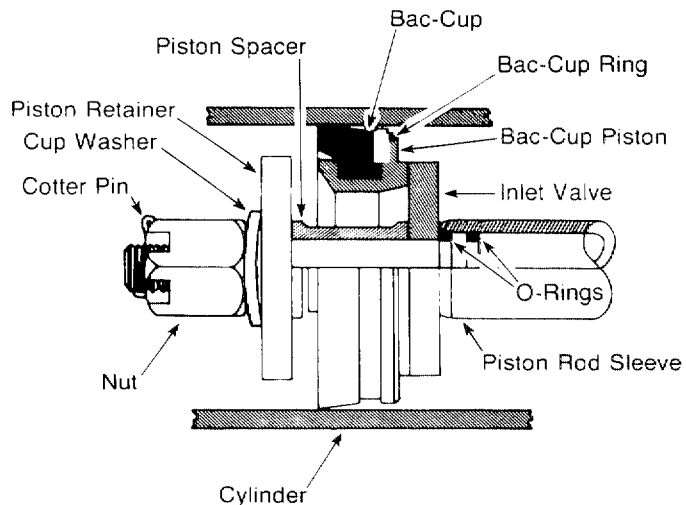



# SERVICING THE VALVE ASSEMBLIES

## DISASSEMBLY:

1. Remove the fasteners securing the discharge manifold to the crankcase of the pump.
2. Support the discharge manifold and tap from the backside and a soft mallet to separate from the crankcase and gradually work free from cylinders.
3. Valve assemblies will remain in the manifold. **Pump models with the o-ring groove on the outside of the valve seat require the assistance of a reverse pliers to remove the valve seat.** The valve, spring and retainer will then fall out when the manifold is inverted.

Pump models without the o-ring groove on the outside of the valve seat permit the seat, valve, spring and retainer all to fall out when manifold is inverted.

## REASSEMBLY:

1. Replace retainers in manifold chambers.
2. Next insert spring into center of retainer.
3. Inspect the valves for wear, ridges or pitting and replace if necessary.

*NOTE: Seating side of flat valves may be lapped on flat surface using 240 grit paper. Quiet valves due to their shape must be replaced.*

Insert valve over spring with recessed (dish) side down.

4. Next examine the seating surface of the flat valve seats and lap with 240 grit paper or replace if evidence of excessive wear. Quiet valve seats should be replaced if worn. Lap new quiet valve and seat to assure positive seal.

5. Some pump models have o-rings and back-up rings on the valve seat. Examine and replace if worn. Always lubricate o-rings for ease of installation and to avoid damaging elastomers.

*NOTE: First install o-ring in groove on seat (towards seating surface), then back-up ring.*

*NOTE: Models without outer groove on seat require the o-ring to be placed on lip of retainer.*

6. Insert valve seats into manifold chambers.
7. Position manifold back onto pump.

*NOTE: Lubricate o-rings on cylinder and exercise caution when slipping manifold over cylinders to avoid damaging cylinder o-rings.*

8. Replace fasteners and torque per specification chart.

*NOTE: Replace all original shims when used. When new manifold is used reshim pump.*

*CAUTION: When starting the pump, check to see that there is no cylinder motion as this will cause premature failure of the cylinder o-rings. Center cylinder motion can be eliminated by switching with one of the end cylinders.*

## SERVICING THE PUMPING SECTION

### DISASSEMBLY:

1. Remove the discharge manifold as described.
2. Grasp cylinders by hand and with an up and down motion, pull cylinders from inlet manifold.
3. Remove cotterpin, nut and washer from piston rod.
4. Next remove *retainer, spacer and piston/cup assembly*.
5. Remove inlet valve.

### REASSEMBLY:

1. Examine inlet valve surfaces for pitting, scale or grooves. Reverse valve and sand inlet side of valve using 240 grit paper for clean surface or replace if evidence of excessive wear. Slip onto rod.
2. Examine piston seating surfaces and sand clean on flat surface using 240 grit paper. If extreme pitting or sharp edges, replace piston.
3. Examine cup for wear, cracking, tearing or separation from the piston. If worn replace and lubricate before installing on piston.

**NOTE CUP INSTALLATION:** Wipe cup inserter with oil. Slip bac-cup ring (when used) onto piston. Push cup over inserter and square with all surfaces. Faulty cup installation causes premature cup failure.

Lubricate piston assembly and slip onto rod.

4. Next replace piston spacer and retainer on rod.
5. Replace washer, thread on nut and torque per specification chart.

*NOTE: Always replace with new Stainless Steel Cotterpin and turn ends under.*

6. Examine cylinder walls for scoring or etching which causes premature wear of cups and replace if worn.
7. Lubricate cylinder and replace o-rings and/or back-up rings if worn or damaged. Carefully slip cylinders over rod ends and push into inlet manifold in their original position. (front to back)
8. Position discharge manifold onto pump, replace fasteners and torque per specification chart.

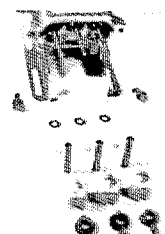
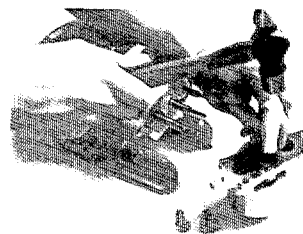
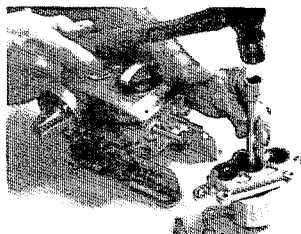
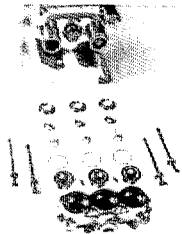

## TORQUE CHART

PISTON ROD NUT			
PUMP MODEL	THREAD	TOOL SIZE	TORQUE
284, 434	M4 x 0.75	8 mm Hex	20-25 kg. cm. 17-22 in. lbs.
250, 260, 300, 420, 500, 524, 624	M5 x 0.9	8 mm Hex	30-55 kg. cm. 26-48 in. lbs.
20, 260, 280, 290, 320, 333, 430, 530, 550, 10 FR, 1000, 1024, 1044	M6 x 1.0	10 mm Hex	50-100 kg. cm. 60 in. lbs.
1020, 1520, 2020	M7 x 1.0	10 mm Hex	60-150 kg. cm. 52-130 in. lbs.
2500, 25 FR.	M8 x 1.25	13 mm Hex	80-200 kg. cm. 130 in. lbs.
6024, 6044	M10 x 1.25	17 mm Hex	120-250 kg. cm. 160 in. lbs.
6020, 6040	M14 x 1.5	22 mm Hex	200-450 kg. cm. 30 ft. lbs.

## MANIFOLD STUD NUT AND CYLINDER BOLTS WHEN USED

PUMP MODEL	THREAD	TOOL SIZE	TORQUE
250, 260, 280, 284, 290, 300, 333, 420, 430, 434, 530, 550	M8 x 1.25	13 mm Hex	125 kg. cm. 125 in. lbs.
310, 320, 500, 520, 10 FR., 650, 1000	M10 x 1.5	17 mm Hex	250 kg. cm. 217 in. lbs.
1024, 1044	M12 x 1.25	19 mm Hex	400 kg. cm. 347 in. lbs.
524, 624, 25 FR, 1024, 1044, 2500	M12 x 1.75	19 mm Hex	400 kg. cm. 365 in. lbs.
6020, 6024, 6040, 6044	M16 x 2.0	22 mm Hex	650 kg. cm. 50-60 ft. lbs.

## TORQUE SEQUENCE

4 BOLT MFLD		8 BOLT MFLD			
3	2	8	1	3	5
<input type="checkbox"/>	<input type="checkbox"/>	<input type="checkbox"/>	<input type="checkbox"/>	<input type="checkbox"/>	<input type="checkbox"/>
<input type="checkbox"/>	<input type="checkbox"/>	<input type="checkbox"/>	<input type="checkbox"/>	<input type="checkbox"/>	<input type="checkbox"/>
1	4	6	4	2	7

## SERVICING SLEEVES AND SEALS

### DISASSEMBLY:

1. Remove discharge manifold and piston assemblies as described.
2. Remove inlet manifold containing seals.
3. Grasp sleeves and with a pulling and twisting motion remove the sleeves from the piston rod.  
  
*NOTE: Grasp sleeve with pliers only if replacing worn sleeves, as this procedure will mar the sleeves.*
4. Next remove seal retainer.
5. Remove and examine o-rings and/or back-up rings on piston rod for wear and replace.

### REASSEMBLY:

1. Lubricate new o-rings and/or back-up rings and slip onto piston rod. Install the first o-ring in the groove on the piston rod. Next position back-up ring against the shoulder in front of the first o-ring. Then install the second o-ring. Exercise caution as you slip the o-ring over the thread end of the piston rod.
2. Examine sleeves for scoring or etching and replace. Immerse sleeves in oil and carefully twist and push sleeve onto rod (machined counter bore end first).
3. Next install seal retainers. If wicks are used, replace wicks, thoroughly saturate with oil, place in seal retainer and install retainer.
4. Place inlet manifold on pair of clearance blocks with *crankcase side down* and drive out old seals.
5. Invert inlet manifold with *crankcase side up* and install new seals. Lubricate circumference of seal and install Prrrrrm-A-

(continued next page)

Lube seal with garter spring down. If using blue dot seal, blue dot should be facing up when installed.

6. Slip lubricated seal inserters onto piston rod ends, position inlet manifold onto pump and remove seal inserters.

*NOTE: Replace original quantity washers on studs before replacing inlet manifold.*

*NOTE: Some models secure inlet manifold to crankcase. Replace fasteners and torque per specification chart.*

7. Reassemble piston assemblies and discharge manifold as described.

## **SERVICING CRANKCASE SECTION**

1. While inlet manifold, sleeves and seal retainers are removed, examine crankcase seals for wear.
2. Check oil level and for evidence of water in oil.
3. Rotate crankshaft by hand to feel for smooth bearing movement.
4. Examine crankshaft oil seal externally for drying, cracking or leaking.
5. Consult factory or your local distributor if crankcase service is evidenced.

# CAT PUMP TROUBLE SHOOTING GUIDE

## **PROBLEM: Pulsation**

<b>Cause</b>	<b>Solution</b>
Debris in discharge valves of pump.	Clean or replace discharge valves.

## **PROBLEM: Low Pressure**

<b>Cause</b>	<b>Solution</b>
Worn nozzle.	Replace nozzle, of proper size.
Belt Slippage.	Tighten or replace; use correct belt.
Air leak in inlet plumbing.	Disassemble, reseal, and reassemble.
Pressure gauge inoperative or not registering accurately.	Check with new gauge; replace worn or damaged gauge, P.N. 06090
Relief valve stuck, partially plugged or improperly adjusted; valve seat worn.	Clean, and adjust relief valve; check for worn and dirty valve seats. Kit available.
Inlet suction strainer clogged or improper size.	Clean. Use adequate size. Check more frequently.
Worn piston assembly. Abrasives in pumped fluid or severe cavitation. Inadequate water supply.	Install proper filter. Suction at inlet manifold must be limited to lifting less than 20 feet of water or -8.5 PSI vacuum.
Fouled or dirty inlet or discharge valves.	Clean inlet and discharge valve assemblies.
Worn inlet or discharge valves.	Replace worn valves, valve seats.
Leaky discharge hose.	Replace discharge hose.

## **PROBLEM: Pumps runs extremely rough, pressure very low**

<b>Cause</b>	<b>Solution</b>
Restricted inlet or air entering the inlet plumbing.	Proper size inlet plumbing; check for air tight seal.
Inlet restrictions and/or air leaks. Damaged cup or stuck inlet or discharge valve.	Replace worn cup or cups, clean out foreign material, replace worn valves.
Worn inlet manifold seals.	Replace worn seals.

*(continued next page)*

## CAT PUMP TROUBLE SHOOTING GUIDE (continued)

### PROBLEM: Cylinder O-rings blown next to discharge manifold

Cause	Solution
Pressures in excess of rated PSI.	Check for plugged nozzle, closed valves or improperly adjusted by-pass valve.
Warped manifold.	Replace manifold.

### PROBLEM: Leakage at the cylinder O-rings at the discharge manifold and black, powdery substance in the area of the O-rings

Cause	Solution
Loose cylinders. Cylinder motion caused by improper shimming of the discharge manifold.	Remove spacer shims on manifold studs. Do not remove too many shims or the ears of the manifold will be bowed when the manifold is retightened, causing looseness in the center cylinder.

### PROBLEM: Water leakage from under the inlet manifold

Cause	Solution
Worn inlet manifold seals. Leaking sleeve O-ring.	Install seals. If piston rod sleeves are scored, replace sleeves and sleeve O-rings.

### PROBLEM: Oil leak between crankcase and pumping section

Cause	Solution
Worn crankcase piston rod seals.	Replace crankcase piston rod seals.
Excess oil from wicks.	Reduce quantity of oil per oiling.

### PROBLEM: Oil leaking in the area of Crankshaft

Cause	Solution
Worn crankshaft seal or improperly installed oil seal retainer packing.	Remove oil seal retainer and replace damaged gasket and/or seals.

---

**PROBLEM: Oil leaking in the area of Crankshaft**

---

<b>Cause</b>	<b>Solution</b>
Bad bearing.	Replace bearing.

---

---

**PROBLEM: Excessive play in the end of the crankshaft pulley**

---

<b>Cause</b>	<b>Solution</b>
Worn main ball bearing from excessive tension on drive belt.	Replace ball bearing. Properly tension belt.

---

---

**PROBLEM: Water in crankcase**

---

<b>Cause</b>	<b>Solution</b>
May be caused by humid air condensing into water inside the crankcase.	Change oil at 3 month or 500 hour intervals using Cat Pump Crankcase Oil (other approved oil every month or 200 hours) P.N.: 06100.
Leakage of manifold inlet seals and/or piston rod sleeve O-ring.	Replace seals, sleeve and O-rings.

---

---

**PROBLEM: Oil leaking from underside of crankcase**

---

<b>Cause</b>	<b>Solution</b>
Worn crankcase piston rod seals.	Replace seals, sleeve and O-rings.

---

---

**PROBLEM: Oil leaking at the rear portion of the crankcase**

---

<b>Cause</b>	<b>Solution</b>
Damaged or improperly installed oil gauge or crankcase rear cover O-ring, and drain plug O-ring.	Replace oil gauge or cover O-ring, and drain plug O-ring.

---

---

**PROBLEM: Oil leakage from drain plug**

---

<b>Cause</b>	<b>Solution</b>
Loose drain plug or worn drain plug O-ring	Tighten drain plug or replace O-ring.

---

(continued next page)

## CAT PUMP TROUBLE SHOOTING GUIDE (continued)

### PROBLEM: Loud knocking noise in pump

Cause	Solution
Pulley loose on crankshaft.	Check key and tighten set screw.
Broken or worn bearing.	Replace bearings.

### PROBLEM: Frequent or premature failure of the inlet manifold seals

Cause	Solution
Scored rods or sleeves.	Replace rods and sleeves.
Over pressure to inlet manifold.	Reduce inlet pressure per instructions.

### PROBLEM: Short cup life

Cause	Solution
Damaged or worn chrome plating of the cylinders.	Replace cylinders.
Abrasive material in the fluid being pumped.	Install proper filtration on pump inlet plumbing.
Excessive pressure and/or temperature of fluid being pumped.	Check pressures and fluid inlet temperature; be sure they are within specified range.
Over pressure of pumps.	Reduce pressure.
Running Pump dry.	Do not run pump without water.
Front edge of piston sharp.	Replace with new piston.
Chrome plating of cylinders damaged causing excessive wear of cups. May be caused by pumping acid solution.	Install new cups and cylinders. Pump only fluid compatible with chrome.

### PROBLEM: Strong surging at the inlet and low pressure on the discharge side

Cause	Solution
Foreign particles in the inlet or discharge valve or worn inlet and/or discharge valves.	Check for smooth lap surfaces on inlet and discharge valve seats. Discharge valve seats and inlet valve seats may be lapped on a very fine oil stone; damaged cups and discharge valves cannot be lapped but must be replaced.



## ELECTRICAL SYSTEM

The entire electrical system operates on 12 volts DC which is provided by your truck's battery. Battery levels are sustained by a 7 amp alternator designed within the engine.

NOTE: When new battery is installed insure it is properly charged before installation or damage to the charging regulator may occur.

---

### PROBLEM: Low Battery Voltage

Cause	Solution
Defective battery.	Remove and replace.
Corroded battery terminals.	Clean terminals and battery posts.
Low battery fluid.	Add water to appropriate level.
Loose wiring within electrical system.	Examine all terminal connections and verify that they are secure.
Electrical short in wiring system.	Examine electrical systems for bare wires.
Poor ground connection.	Examine terminal and remove corrosion if necessary.

---

### PROBLEM: Inoperative Hour Meter

Cause	Solution
Time is not advancing correctly.	Verify 12 volts DC is available at the hour meter with the ignition switch turned on. This can be accomplished with a volt meter or a test lamp.  Remove and replace hour meter if 12 volts is available.  A nylon gear within the clock may have been jammed due to a sudden jolt of the machine or truck. You may try simply tapping on the meter to try to free the nylon gear.

---



## **FREEZE PROTECTION**

**Any freezing** of this machine is not covered by warranty and during the colder months of operation, careful protection should be of utmost concern.

THE FOLLOWING PRECAUTIONS ARE RECOMMENDED:

1. Run machine before leaving for the first job to insure nothing has frozen the night before, including hoses and wand.
2. Insulate the garden hose from the cold ground by running it through an extra 1½ inch vacuum hose.
3. Leave truck doors closed until time cleaning begins, then open slightly.
4. In colder climates, insulating the truck walls and floor boards will help protect the unit.
5. Don't procrastinate during the cleaning operation or the hot water solution line will also freeze on the ground. The solution line should be insulated in extremely cold climates.
6. Whenever possible, the truck should be stored in a heated garage at night or over the weekend. If not possible, place a 1500 watt electric heater inside the truck, aimed directly at the machine. Never use a propane heater - it causes excessive moisture on the truck ceiling and the possibility of it going out is higher. If the machine and truck are left outside with a heater, you should first drain all possible water from the machine cleaning tools and hoses. (They freeze also.)

TO DRAIN THE MACHINE, FOLLOW THESE STEPS:

- A. Before shutting off the machine, remove the chemical line from the chemical jug and place in a mixture of 50/50 anti-freeze and water. With the cleaning tool on, allow mixture to fill chemical system back to the chemical mix tank.
- B. Open the mix tank drain valve and allow the water to drain thoroughly from the mix tank.

C. To remove the water from the heat exchanger and pump use the freeze guard which is a small air compressor. Using the correct connectors, first blow air into the high pressure solution male quick connect. This will force the water through the heat exchanger back through the pump and into the chemical mix tank to be drained out through the petcock valve to the ground. By loosening the bypass knob, the air will be allowed to flow more freely through the system. Next, blow the air into the incoming water quick connect and force that water into the chemical mix tank to be drained out.

D. Remember to close the drain valve prior to next operation of your CDS unit.

Check ENGINE Antifreeze regularly.

**BE SURE IT'S PROTECTED!**

**Freezing will cause GRIEF, MONEY and DOWN-TIME. Don't mess with mother nature!**

## **CLEANING AND CHEMICAL PRECAUTIONS INFORMATION**

Your mobile carpet cleaning plant has been engineered using the latest and most sophisticated technology available, to produce the finest carpet cleaning results possible. Despite this however, it remains only a tool of the carpet cleaning trade, and it can produce only as good a job as the person operating it.

There are no short cuts to good carpet cleaning, it requires time, cleaning knowledge and the use of good chemicals.

Manufacturer recommends the use of spotting agents, and traffic lane cleaners prior to the actual cleaning of carpeting, as required.

**CAUTION** when cleaning cut-pile acrilan plush carpets: Using high heat setting may result in fiber damage.

*(continued next page)*

The use of some chemicals through your mobile carpet cleaning plant can seriously damage the internal plumbing, high pressure pump and heater. (Chemical such as concentrated acids and some paint oil and grease removers w/high concentration of solvents.)

Manufacturer recommends only the use of chemicals containing rust and corrosion inhibitors and water softening agents to prevent chemical build-up.

NOTE: At no time should a chemical solution with pH of less than 7 or higher than 10 be used in the unit.

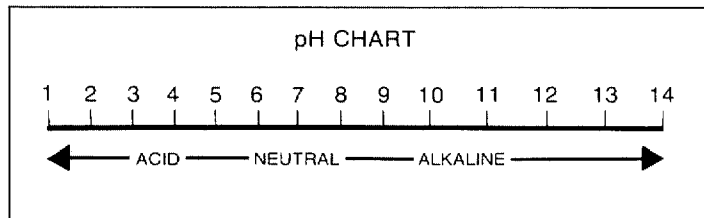

## CLEANING STROKE PROCEDURE/OVER-WETTING

### Purpose:

To eliminate excess moisture remaining in the carpet fiber and the sawtooth appearance which results from diagonal movement of the cleaning tool on all types of carpet.

### Procedure:

Always move the cleaning tool in smooth forward and backward strokes. Apply **slight** pressure to the forward stroke while the solution is injected into the carpet. When extracting (drying), apply firm pressure on the forward stroke to ensure a positive "lock" for the vacuum and minimize the "hopping" effect resulting on unsmooth

carpet. During the forward and reverse strokes, movement to the right or left should only be accomplished at the extreme rear of the stroke. Overlapping is also important to ensure even application of solution to prevent saturation when cleaning wand is stopped twice at the same point at the rear of the cleaning stroke.

Failure to adopt this procedure can result in increased chance of "clean streaks", fiber shrinkage, brown out, and longer drying periods.

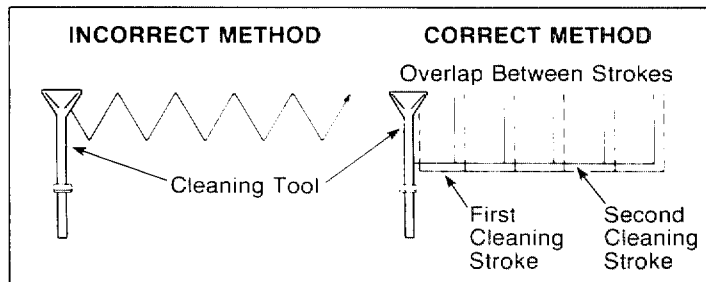

### Over-Wetting

Over-wetting is annoying to all concerned and sometimes leaves a bad impression of the cleaning process used.

These are several areas that will cause over-wetting:

1. Too few vacuum strokes or improper saw tooth vacuum strokes as shown above.
2. Obstructed, kinked or cut hoses.
3. Vacuum tank drain valve left partially open.
4. Clogged vacuum blower filter or vacuum tank lid not sealing properly.
5. Cleaning a heavily foam-saturated carpet without defoamer. (We recommend crystal type.)

## MAINTENANCE PROCEDURES

To avoid costly repairs and down-time, it is imperative to develop and practice good maintenance procedures from the beginning. These procedures fall into daily, weekly, monthly and quarterly increments, and are outlined below. We have provided a maintenance log for your convenience on page 38; it is recommended that you affix a copy of the log on the vehicle door near your unit for convenience and to serve as a maintenance reminder.

### Daily

- Check engine oil level.
- Inspect garden hose screen - clean as needed.
- Visually inspect machine for loose wires, oil leaks, water leaks, etc.
- Inspect recovery tank s/s filter and filter bag for tears, holes, etc. - clean, repair or replace as needed.
- Lubricate blower with LPS-1 or WD-40 through blower inlet.

**Daily:** Wipe machine down thoroughly with a damp cloth; flush recovery tank out thoroughly. Empty filter bag and inspect for rips, tears, etc. - replace as needed; remove, thoroughly clean and reinstall stainless steel filter screen in recovery tank; inspect and clean vacuum slot on cleaning wand; check wand head for sharp edges that could tear carpet - file down as needed; clean wand to maintain original appearance; wipe down vacuum and high pressure hoses as needed - visually inspect for cuts, etc.

### Weekly

- Check engine air cleaner filter - clean as necessary.
- Check high pressure pump oil - add as necessary.
- Check pump drive belt for wear - tighten as needed.
- Check pump pulleys - tighten as needed.

- Check lines for wear/chafing.
- Check all nuts and bolts - tighten as needed.
- Clean vacuum tank thoroughly with high pressure washer.
- Flush water and chemical system with 50/50 white vinegar solution.
- Check engine RPM's - adjust to 1200 RPM's at the pump.

**IMPORTANT:** Record date and machine hours on maintenance chart.

### Monthly

- Grease blower bearing fittings.
- Remove pressure bypass valve stem, grease cup and stem, reinstall.
- Check water level in battery. Clean connections as needed.

**IMPORTANT:** Record date and machine hours on maintenance chart.

### Quarterly

- Change oil in blower (see blower manual).

## OVERALL CARE OF UNIT

MAINTAINING THE ORIGINAL APPEARANCE OF YOUR UNIT IS IMPORTANT FOR TWO REASONS:

1. It represents a big dollar investment for your cleaning business and its appearance should reflect that fact. A dirty machine is not professional!
2. Maintenance, troubleshooting, and repair is much easier to accomplish on a clean well maintained unit. Regular cleaning of the machine offers you an opportunity to visually inspect all facets of the machine and spot potential problems before they occur.

# **FREEZE PROTECTION OF CLUTCH DRIVE WITH PUMP-IN SYSTEM**

1. Start with machine in cleaning mode.
2. Drain chemical mix tank. (fig. 1)
3. While chemical mix tank is draining: Insert chemical feed line into antifreeze premix jug and allow meter to fill with premix anti freeze for 10 seconds. Close chemical flow meter when protected. (fig. 2) As shown on page 33 #C.
4. Shut machine down. Connect short hose to high pressure quick connector and drain heat exchanger of cleaning water. (fig. 3)
5. Remove pump-in system hose from water storage tank and insert it into antifreeze premix jug. (fig. 4)

6. Close chemical mix tank drain valve and allow pump-in system to refill mix tank with antifreeze premix solution. (fig. 5)
7. Start unit with cleaning wand and hoses connected and spray into a bucket for 20 seconds to allow the antifreeze to protect the high pressure gauge and system lines. After running the wand spray for 20 seconds. shut wand off and let it run for 10 seconds to allow the bypass system to be protected. (fig. 6)
8. Turn off cleaning system Master Power Switch. You may want to leave the pump-in hose out of the tank so it won't freeze to the residual water in the tank. The next day, refill the tank and replace the hose. If layer of ice, the hose will sit on top of it and gain proper suction.
9. Reconnect pump-in hose to water storage tank.



Fig. 1

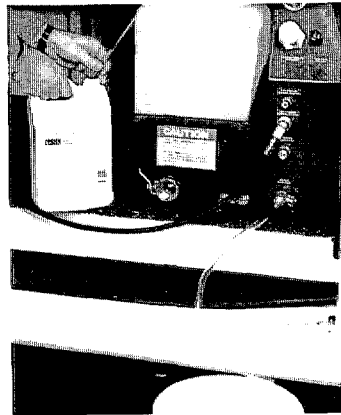

Fig. 2



Fig. 3

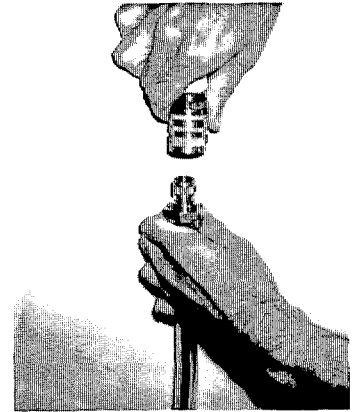

Fig. 4

10. Place bucket under drain hose of chemical mix tank and open drain valve again to reclaim antifreeze premix. When tank is empty, reconnect short hose to high pressure quick connector and drain heat exchanger into bucket. (fig. 7)
11. Shut off valves and pour all reclaimed antifreeze from bucket back into the 5 gallon antifreeze premix jug so it can be used again. (fig. 8)
12. Before cleaning the next day run unit for 3 minutes to void all excess antifreeze from the system.

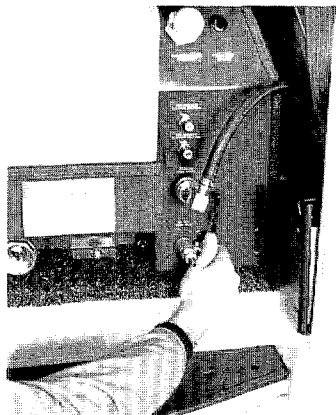

Fig. 5

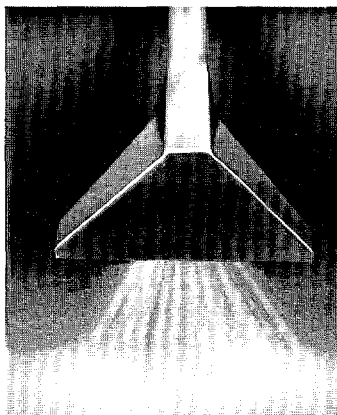

Fig. 6



Fig. 7



Fig. 8

# MAINTENANCE LOG

## YEARLY TRUCK MAINTENANCE:

- \* Complete Tune Up
- \* Flush Cooling System  
(New Anti-Freeze)
- \* Change Transmission Fluid

### DAILY CLEANING & INSPECTION

Engine oil - check      Clean vac tank filter bag after every job  
 Garden hose screen - clean      Blower inlet - spray with LPS 1 after last job  
 Machine - general inspection

### WEEKLY SERVICE

MAX HRS	SERVICE	DATE HRS	DATE HRS	DATE HRS	DATE HRS	DATE HRS	DATE HRS	DATE HRS
25	BLOWER check oil level							
25	PUMP OIL check (top of sight gauge)							
25	DRIVE SHAFT SYSTEM tighten set screws							
25	BELTS & PULLEYS check tightness							
25	HIGH PRESSURE LINES check for chafing							
25	NUTS & BOLTS check tightness							
25	BATTERY LEVELS check							
25	VACUUM TANK clean							
25	WIRING check for chafing							
25	CHEMICAL SYSTEM flush w.vinegar							

### MONTHLY SERVICE

100	ENGINE OIL change							
100	BLOWER grease bearing							
100	ENGINE AIR CLEANER clean							
100	BY PASS VALVE grease cup & stem							

### QUARTERLY SERVICE (3 MONTHS)

300	BLOWER OIL change							
300	ENGINE compression							
300	SPARK PLUGS change							



# MAINTENANCE LOG

## YEARLY TRUCK MAINTENANCE:

### DAILY CLEANING & INSPECTION

Engine oil - check      Clean vac tank filter bag after every job  
 Garden hose screen - clean      Blower inlet - spray with LPS 1 after last job  
 Machine - general inspection

- \* Complete Tune Up
- \* Flush Cooling System  
 (New Anti-Freeze)
- \* Change Transmission Fluid

### WEEKLY SERVICE

MAX HRS	SERVICE	DATE/HRS	DATE/HRS	DATE/HRS	DATE/HRS	DATE/HRS	DATE/HRS	DATE/HRS
25	BLOWER check oil level							
25	PUMP OIL check (top of sight gauge)							
25	DRIVE SHAFT SYSTEM tighten set screws							
25	BELTS & PULLEYS check tightness							
25	HIGH PRESSURE LINES check for chafing							
25	NUTS & BOLTS check tightness							
25	BATTERY LEVELS check							
25	VACUUM TANK clean							
25	WIRING check for chafing							
25	CHEMICAL SYSTEM flush w/vinegar							

### MONTHLY SERVICE

100	ENGINE OIL change							
100	BLOWER grease bearing							
100	ENGINE AIR CLEANER clean							
100	BY PASS VALVE grease cup & stem							

### QUARTERLY SERVICE (3 MONTHS)

300	BLOWER OIL change							
300	ENGINE compression							
300	SPARK PLUGS change							

## WARRANTY INFORMATION

To avoid misunderstandings which might occur between machine owners and manufacturer, we are listing causes of component failure that specifically voids warranty coverage. Such causes as listed below shall constitute **abuse or neglect**.

**BLOWER:** Failure to lubricate impellers daily with LPS-1 or WD-40 lubricant. Failure to lubricate bearings. Failure to maintain proper oil levels in the blower. Failure to use the correct oil grade and viscosity as recommended. Failure to properly maintain blower safeguard systems such as waste tank filter screen, vacuum safety relief valve in vacuum tank lid and waste tank automatic shut-off system. Allowing foam to pass through blower.

**HIGH PRESSURE WATER PUMP:** Operation of pump at pressure over 1200 PSI. Failure to maintain proper oil level as recommended. Failure to change oil in pump at recommended intervals. Failure to protect pump against freezing. Failure to maintain pump protection shut-off system. Failure to use water softener in hard water areas. Use of improper chemicals.

**VAC TANK:** Failure to properly maintain filtering devices in tank. Failure to clean tank as recommended by manufacturer. Failure to maintain vacuum safety release in tank. Use of improper chemicals.

**CHEMICAL PROPORTIONER:** Use of improper chemical. Failure to use water softener in hard water area. Operating machine without proper chemical filter screen. Failure to protect against freezing.

**CONTROL PANEL:** Failure to protect flow meter and water pressure gauge against freezing.

**VACUUM AND SOLUTION HOSES:** Failure to protect hoses against freezing. Failure to protect hoses against burns from engine/blower exhaust. Damage to hoses from being run over by

vehicles. Kinking or cracking from failure to store or unroll hoses correctly. Normal wear and tear from everyday use.

**CLEANING WAND:** Failure to protect against freezing. Obvious physical abuse of wand.

## WARRANTY PROCEDURE

Warranty coverage is available to you **ONLY** through HydraMaster Corporation, 20309 64th Ave. West, Lynnwood, Washington 98036. When warranty parts are needed, write **HydraMaster Warranty Dept.** at the above address, or call the Warranty/Service Dept. at (206) 775-7275. **No collect calls will be accepted. Hours of Warranty/Service Dept. are 7:00 am to 6:00 pm Pacific Time.**

## IMPORTANT

HydraMaster's warranty policy provides replacement parts without charge for thirty (30) days to customers maintaining current account status. An invoice dated thirty (30) days from date of replacement parts shipment will be sent to the customer for the amount of the parts sent. The customer's faulty parts **must be returned** for evaluation prior to the expiration of the thirty (30) day period. Upon warranty approval, a credit will be issued the customer for the replacement parts invoice. **Warranty disapproval or failure to return the faulty parts within the thirty (30) day period allowed will result in the customer being charged for the replacement parts sent.**

## HydraMaster LIMITED WARRANTY

HydraMaster warrants products of its manufacture to be free from defects in material and workmanship if properly installed, maintained, and operated under normal conditions with competent supervision. No person, agent, representative or dealer is authorized to give any warranties on behalf of HydraMaster nor to assume for HydraMaster any other liability in connection with any of HydraMaster's products. This warranty shall extend for the periods listed by component below from date of installation. If repairs or replacements are made by the Purchaser without HydraMaster's written consent, HydraMaster's warranty shall cease to be in effect. No allowance will be granted for any repairs or alterations made by the Purchaser without HydraMaster's prior written consent.

Machinery, equipment and accessories furnished by HydraMaster, but manufactured by others, are warranted only to the extent of the original manufacturer's warranty to HydraMaster.

HydraMaster agrees at its option to repair at the point of shipment or to replace without charge f.o.b. point of shipment, any parts or parts of products of HydraMaster's manufacture, which within the specified warranty period shall be proved to HydraMaster's satisfaction to have been defective when shipped, provided the Purchaser promptly notifies HydraMaster, in writing, of such alleged defect.

HydraMaster's liability to Purchaser, whether in contract or in tort arising out of warranties, representation, instructions, or defects from any cause shall be limited to repairing or replacing of the defective part or parts as aforesaid, f.o.b. point of shipment.

No liability whatsoever shall attach to HydraMaster until said products have been paid for.

Except as stated in this section and in the preceding section titled "Warranty" and except as to title, there are no guarantees or warranties of merchantability, fitness, performance or otherwise, express, implied or statutory, and HydraMaster shall have no liability for consequential, incidental or other damages, howsoever caused.

**ENGINE:** (Thru original Manufacturer. See Truck Manual warranty.)

**VACUUM BLOWER:** (Thru original Manufacturer. See Fuller warranty.) 1 year

**VACUUM RECOVERY TANK/CHEMICAL MIX TANKS:** 3 years

**FRAME/COVER ASSEMBLIES:** 3 years

**HIGH PRESSURE PUMP:** (Thru original Manufacturer. See Cat Pump warranty.) 1 year

**HIGH PRESSURE BY PASS VALVE:** 90 days

**CHEMICAL PROPORTIONING SYSTEM:** 90 days

**INTERNAL MACHINE HOSE:** 1 year

**EXTERNAL VACUUM HOSE, SOLUTION HOSE, QUICK CONNECTORS:** 30 days

**CLEANING WAND:** (Except valve & jet assembly) 1 year

**BELTS, FITTINGS, O-RINGS, FILTER SCREENS:** 30 days

**FILTER BAGS:** Not Covered by Warranty

Freezing of any one water or chemical related component will VOID all other implied warranty on all water or chemical related components, internal or external, of this equipment.

**HYDRAMASTER**  
Corporation

