

READ THIS FIRST



Model G0504

*****IMPORTANT UPDATE*****

**For Machines Mfd. Since 11.14
and Owner's Manual Revised 11.07**

For questions or help with this product contact Tech Support at (570) 546-9663 or techsupport@grizzly.com

The following changes were recently made to this machine since the owner's manual was printed:

- Changed elevation motor, main motor, and various electrical components.

Aside from this information, all other content in the owner's manual applies and **MUST** be read and understood for your own safety. **IMPORTANT: Keep this update with the owner's manual for future reference.**

For questions or help, contact our Tech Support at (570) 546-9663 or techsupport@grizzly.com.

New Parts

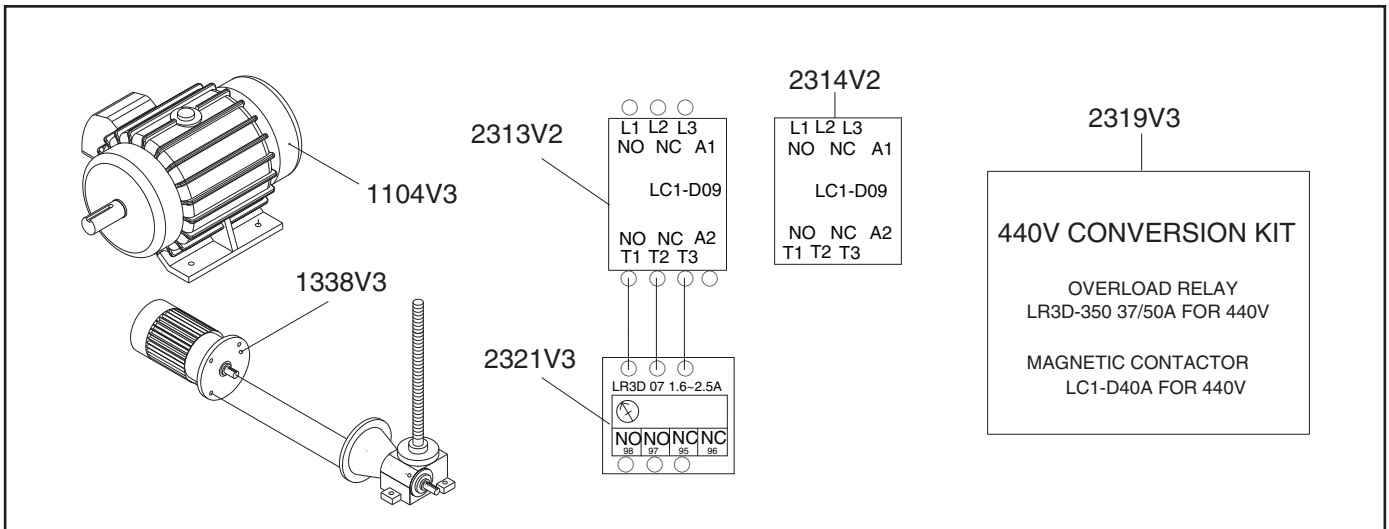

REF	PART #	DESCRIPTION
1104V3	P05041104V3	MOTOR 30HP 220V/440V 3-PH V3.11.14
1338V3	P05041338V3	GEAR BOX & MOTOR V3.11.14
2313V2	P05042313V2	CONTACTOR TE LCI-D09 220V V2.11.14

REF	PART #	DESCRIPTION
2314V2	P05042314V2	CONTACTOR TE LCI-D09 V2.11.14
2319V3	P05042319V3	440V CONVERSION KIT FOR G0504 V3.11.14
2321V3	P05042321V3	OL RELAY TE LR3D-07 1.6-2.5A V3.11.14

COPYRIGHT © SEPTEMBER, 2016 BY GRIZZLY INDUSTRIAL, INC.
**WARNING: NO PORTION OF THIS MANUAL MAY BE REPRODUCED IN ANY SHAPE
OR FORM WITHOUT THE WRITTEN APPROVAL OF GRIZZLY INDUSTRIAL, INC.**
#BL18354 PRINTED IN TAIWAN

New Motor Wiring

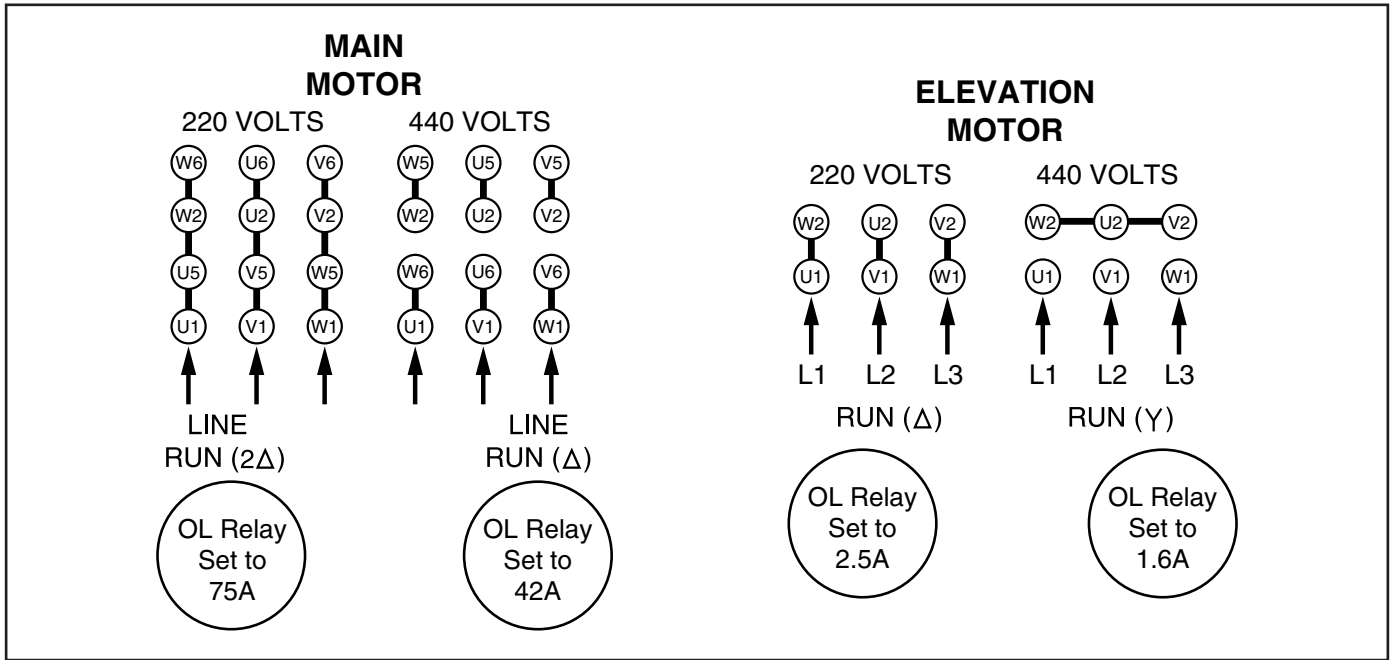

New Specifications

Electrical

Full-Load Current Rating.....	75A at 220V, 37.5A at 440V
Minimum Circuit Size.....	100A at 220V, 50A at 440V
Voltage Conversion Kit.....	P05042319V3 for 440V

Motors:

Main

Amps72.9/36.4A

Elevation

Amps1.94/0.97A
 Speed1680 RPM



Grizzly *Industrial, Inc.*®

MODEL G0504 16" HORIZONTAL RESAW BANDSAW Owner's Manual



COPYRIGHT © MAY, 2003 BY GRIZZLY INDUSTRIAL, INC. REVISED NOVEMBER, 2007.
**WARNING: NO PORTION OF THIS MANUAL MAY BE REPRODUCED IN ANY SHAPE
OR FORM WITHOUT THE WRITTEN APPROVAL OF GRIZZLY INDUSTRIAL, INC.**
#TR5063 PRINTED IN TAIWAN

 **WARNING!**

This manual provides critical safety instructions on the proper setup, operation, maintenance and service of this machine/equipment.

Failure to read, understand and follow the instructions given in this manual may result in serious personal injury, including amputation, electrocution or death.

The owner of this machine/equipment is solely responsible for its safe use. This responsibility includes but is not limited to proper installation in a safe environment, personnel training and usage authorization, proper inspection and maintenance, manual availability and comprehension, application of safety devices, blade/cutter integrity, and the usage of personal protective equipment.

The manufacturer will not be held liable for injury or property damage from negligence, improper training, machine modifications or misuse.

 **WARNING!**

Some dust created by power sanding, sawing, grinding, drilling, and other construction activities contains chemicals known to the State of California to cause cancer, birth defects or other reproductive harm. Some examples of these chemicals are:

- **Lead from lead-based paints.**
- **Crystalline silica from bricks, cement and other masonry products.**
- **Arsenic and chromium from chemically-treated lumber.**

Your risk from these exposures varies, depending on how often you do this type of work. To reduce your exposure to these chemicals: Work in a well ventilated area, and work with approved safety equipment, such as those dust masks that are specially designed to filter out microscopic particles.

Table of Contents

SECTION 1: GENERAL INFORMATION	3
Commentary	3
Machine Data Sheet	4
SECTION 2: SAFETY	5
Additional Safety Instructions for Bandsaws	7
Additional Safety Instructions for Hydraulics	8
SECTION 3: CIRCUIT REQUIREMENTS	9
3-Phase Power	9
Grounding	10
Converting to 440V	10
SECTION 4: MACHINE FEATURES	12
Main Features	12
Control Panel	14
SECTION 5: SET UP	15
About this Section	15
Unpacking	15
Piece Inventory	15
Hardware Recognition Chart	16
Clean Up	17
Site Considerations	17
Removing Resaw from Crate Pallet	18
Mounting Resaw to the Floor	18
Installing & Tensioning Blade	19
Adjusting Blade Guides	20
Connecting to Dust Collector	22
Connecting to Power Source	22
Test Run	23
SECTION 6: OPERATIONS	24
Operation Safety	24
Conveyor Controls	24
Setting Blade Height	25
Calibrating Digital Display	25
Setting Memory Button	26
Using Memory Preset Keys	26
Resawing	27
Blade Information	28
Accessories	29
SECTION 7: MAINTENANCE	30
Cleaning	30
Miscellaneous	30
V-Belts	30
Bearings	30
Grease Fittings	31
Hydraulic Fluid Schedule	32
Hydraulic System Minor Service	32
Hydraulic System Major Service	33

SECTION 8: SERVICE ADJUSTMENTS	35
About Service	35
Adjusting Lower Blade Guides	35
Adjusting V-Belt Tension	36
Replacing V-Belts	37
Adjusting Main Conveyor Table	37
Tracking Conveyors	38
Replacing Conveyors	39
Blade Tracking and Wheel Alignment	41
Troubleshooting	44
SECTION 9: Parts	46
Housing Parts	46
Frame Parts	48
Elevation Parts	49
Blade Guide Parts	51
Tensioning Wheel Parts	53
Drive Wheel Parts	55
Hydraulic Pump Parts	56
Main Conveyor Table Parts	57
Return Conveyor Table Parts	59
Rear Hold Down Parts	60
Front Hold Down Parts	61
Hydraulic System Parts	62
Electrical System Parts 1	64
Electrical System Parts 2	65

SECTION 1: GENERAL INFORMATION

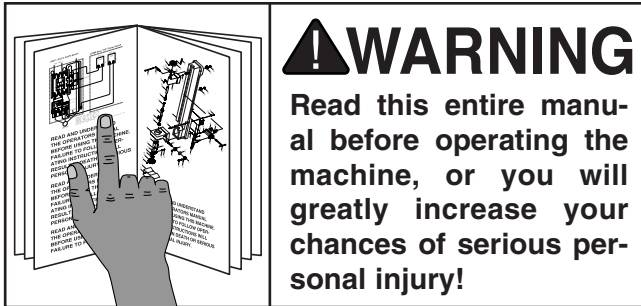

Commentary

Grizzly Industrial, Inc. is proud to offer the Model G0504 16" Horizontal Resaw Bandsaw. This resaw bandsaw is part of Grizzly's growing family of fine woodworking machinery. When used according to the guidelines stated in this manual, you can expect years of trouble-free, enjoyable operation, and proof of Grizzly's commitment to customer satisfaction.

We are also pleased to provide this manual for the Model G0504. It was written to guide you through assembly, review safety considerations, and cover general operating procedures. It represents our latest effort to produce the best documentation possible.

If you have any comments or criticisms that you feel we should address in our next printing, please contact us at:

Grizzly Industrial, Inc.
% Technical Documentation
P.O. Box 2069
Bellingham, WA 98227
Email: manuals@grizzly.com

Most important, we stand behind our machines. We have excellent regional service departments at your disposal should the need arise.

If you have any service questions or parts requests, please call or write to us at the location listed below.

Grizzly Industrial, Inc
1203 Lycoming Mall Circle
Muncy, PA 17756
Phone:(570) 546-9663
Fax:(800) 438-5901
E-Mail: techsupport@grizzly.com
Web Site: <http://www.grizzly.com>

The specifications, drawings, and photographs illustrated in this manual represent the Model G0504 as supplied when the manual was prepared. However, owing to Grizzly's policy of continuous improvement, changes may be made at any time with no obligation on the part of Grizzly. For your convenience, we always keep current Grizzly manuals available on our website at www.grizzly.com. Any updates to your machine will be reflected in these manuals as soon as they are complete.





MACHINE DATA SHEET

Customer Service #: (570) 546-9663 · To Order Call: (800) 523-4777 · Fax #: (800) 438-5901

MODEL G0504 16" DUAL CONVEYOR HORIZONTAL RE-SAW BANDSAW

Product Dimensions:

Weight..... 3740 lbs.
 Length/Width/Height..... 108 x 85 x 83-1/2 in.
 Foot Print (Length/Width)..... 45-1/4 x 32-1/4 in.

Shipping Dimensions:

Type..... Wood Slat Crate
 Content..... Machine
 Weight..... 4180 lbs.
 Length/Width/Height..... 114" x 92" x 85"

Electrical:

Switch..... Magnetic with Thermal Overload Protector
 Switch Voltage..... 220V
 Recommended Breaker Size..... 90 Amp
 Plug..... No
 Conversion To 440V..... P0504919A

Motors:

Main

Type..... TEFC Induction
 Horsepower..... 30 HP
 Voltage..... 220/440V
 Prewired..... 220V
 Phase..... Three
 Amps..... 72/41A
 Speed..... 1725 RPM
 Cycle..... 60 Hz
 Number Of Speeds..... 1
 Power Transfer Belt Drive
 Bearings..... Shielded and Lubricated

Elevation

Type..... TEFC Induction
 Horsepower..... 1/2 HP
 Voltage..... 220/440V
 Prewired..... 220V
 Phase..... Three
 Amps..... 2.2/1.1A
 Speed..... 1725 RPM
 Cycle..... 60 Hz
 Number Of Speeds..... 1
 Power Transfer Belt Drive
 Bearings..... Shielded and Lubricated

Main Specifications:

Operation

Blade Speeds..... 7300 FPM
Feed Speed..... 0 - 61 FPM

Cutting Capacities

Height Capacity At Blade..... 10 in.
Maximum Workpiece Width..... 16 in.

Blade Information

Standard Blade Length..... 180 in.
Blade Width Range..... 1 in.
Upper Blade Guides..... Ceramic
Lower Blade Guides..... Ceramic

Table Information

Floor to Table Height..... 40 in.

Conveyor Information

Distance from Blade to Conveyor Table..... 1/4 - 10 in.
Conveyor Table Width..... 16 in.
Conveyor Table Length..... 106 in.
Conveyor Table Thickness..... 4-3/4 in.
Floor to Back Roller Height..... 30 in.
Feed Belt Length..... 215-3/4 in.
Feed Belt Width..... 15-1/4 in.
Return Belt Length..... 215-3/4
Return Belt Width..... 7-1/4

Construction

Base Construction..... Steel
Body Construction..... Steel
Left Wheel Steel
Right Wheel Steel
Wheel Cover Pre-Formed Steel
Conveyor Belt Rubber
Conveyor Table Steel
Pressure Roller Cast Iron w/ Polyurethane
Paint..... Epoxy

Other Related Information

Wheel Diameter..... 28 in.
Wheel Width..... 7/8 in.
Hydraulic Pressure..... 1000 PSI
Pressure Roller Diameter..... 4 in.
Number of Dust Ports..... 2
Dust Port Size..... 4 in.

Other Specifications:

Country Of Origin Taiwan
Warranty 1 Year
Serial Number Location Label on Blade Guard
Assembly Time 30 minutes

Features:

- Digital Position Controller for Accurate Saw Wheel Positioning
- Powered Saw Wheel Elevation
- Return Conveyor
- Automatic Hydraulic Blade Tension Control and Indicator
- Lifting Wheel Guard
- Bi-fold Doors

SECTION 1: SAFETY

WARNING

For Your Own Safety, Read Instruction Manual Before Operating this Machine

The purpose of safety symbols is to attract your attention to possible hazardous conditions. This manual uses a series of symbols and signal words intended to convey the level of importance of the safety messages. The progression of symbols is described below. Remember that safety messages by themselves do not eliminate danger and are not a substitute for proper accident prevention measures.



Indicates an imminently hazardous situation which, if not avoided, **WILL** result in death or serious injury.



Indicates a potentially hazardous situation which, if not avoided, **COULD** result in death or serious injury.



Indicates a potentially hazardous situation which, if not avoided, **MAY** result in minor or moderate injury. It may also be used to alert against unsafe practices.

NOTICE

This symbol is used to alert the user to useful information about proper operation of the machine.

WARNING

Safety Instructions for Machinery

- 1. READ THE ENTIRE MANUAL BEFORE STARTING MACHINERY.** Machinery presents serious injury hazards to untrained users.
- 2. ALWAYS USE ANSI APPROVED SAFETY GLASSES WHEN OPERATING MACHINERY.** Everyday eyeglasses only have impact resistant lenses—they are NOT safety glasses.
- 3. ALWAYS WEAR A NIOSH APPROVED RESPIRATOR WHEN OPERATING MACHINERY THAT PRODUCES DUST.** Most types of dust (wood, metal, etc.) can cause severe respiratory illnesses.
- 4. ALWAYS USE HEARING PROTECTION WHEN OPERATING MACHINERY.** Machinery noise can cause permanent hearing loss.
- 5. WEAR PROPER APPAREL. DO NOT** wear loose clothing, gloves, neckties, rings, or jewelry that can catch in moving parts. Wear protective hair covering to contain long hair and wear non-slip footwear.
- 6. NEVER OPERATE MACHINERY WHEN TIRED OR UNDER THE INFLUENCE OF DRUGS OR ALCOHOL.** Be mentally alert at all times when running machinery.

WARNING

Safety Instructions for Machinery

7. **ONLY ALLOW TRAINED AND PROPERLY SUPERVISED PERSONNEL TO OPERATE MACHINERY.** Make sure operation instructions are safe and clearly understood.
8. **KEEP CHILDREN AND VISITORS AWAY.** Keep all children and visitors a safe distance from the work area.
9. **MAKE WORKSHOP CHILDPROOF.** Use padlocks, master switches, and remove start switch keys.
10. **NEVER LEAVE WHEN MACHINE IS RUNNING.** Turn power **OFF** and allow all moving parts to come to a complete stop before leaving machine unattended.
11. **DO NOT USE IN DANGEROUS ENVIRONMENTS.** DO NOT use machinery in damp, wet locations, or where any flammable or noxious fumes may exist.
12. **KEEP WORK AREA CLEAN AND WELL LIGHTED.** Clutter and dark shadows may cause accidents.
13. **USE A GROUNDED EXTENSION CORD RATED FOR THE MACHINE AMPERAGE.** Grounded cords minimize shock hazards. Undersized cords create excessive heat. Always replace damaged extension cords.
14. **ALWAYS DISCONNECT FROM POWER SOURCE BEFORE SERVICING MACHINERY.** Make sure switch is in OFF position before reconnecting.
15. **MAINTAIN MACHINERY WITH CARE.** Keep blades sharp and clean for best and safest performance. Follow instructions for lubricating and changing accessories.
16. **MAKE SURE GUARDS ARE IN PLACE AND WORK CORRECTLY BEFORE USING MACHINERY.**
17. **REMOVE ADJUSTING KEYS AND WRENCHES.** Make a habit of checking for keys and adjusting wrenches before turning machinery **ON**.
18. **CHECK FOR DAMAGED PARTS BEFORE USING MACHINERY.** Check for binding or misaligned parts, broken parts, loose bolts, and any other conditions that may impair machine operation. Repair or replace damaged parts before operation.
19. **USE RECOMMENDED ACCESSORIES.** Refer to the instruction manual for recommended accessories. Improper accessories increase risk of injury.
20. **DO NOT FORCE MACHINERY.** Work at the speed for which the machine or accessory was designed.
21. **SECURE WORKPIECE.** Use clamps or a vise to hold the workpiece when practical. A secured workpiece protects your hands and frees both hands to operate the machine.
22. **DO NOT OVERREACH.** Maintain stability and balance at all times.
23. **MANY MACHINES CAN EJECT WORKPIECES TOWARD OPERATOR.** Know and avoid conditions that cause the workpiece to "kickback."
24. **ALWAYS LOCK MOBILE BASES (IF USED) BEFORE OPERATING MACHINERY.**
25. **CERTAIN DUST MAY BE HAZARDOUS** to the respiratory systems of people and animals, especially fine dust. Be aware of the type of dust you are exposed to and always wear a respirator designed to filter that type of dust.

WARNING

Additional Safety Instructions for Bandsaws

- 1. DO NOT OPERATE WITH DULL OR BADLY WORN BLADES.** Dull blades require more demand on the motor and are less likely to cut precisely. Inspect blades before each use.
- 2. NEVER POSITION FINGERS OR THUMBS IN LINE WITH THE CUT.** Serious personal injury could occur.
- 3. DO NOT OPERATE THIS BANDSAW WITHOUT WHEEL GUARDS, PULLEY GUARDS, AND BLADE GUARDS IN PLACE.**
- 4. WHEN REPLACING BLADES,** make sure the teeth face toward the front of the saw.
- 5. CUTS SHOULD ALWAYS BE FULLY SUPPORTED** against the side of the conveyor table and by the pressure rollers.
- 6. DO NOT BACK WORKPIECE AWAY** from the blade while the saw is running. If you need to back the work out, stop the bandsaw and wait for the blade to stop. **DO NOT** twist or put excessive stress on blade while backing work away.
- 7. BLADE SHOULD BE RUNNING AT FULL SPEED** before beginning a cut.
- 8. ALWAYS FEED STOCK EVENLY AND SMOOTHLY.** **DO NOT** change conveyor speeds during a cut.
- 9. THIS MACHINE IS NOT DESIGNED TO CUT METAL** or other material except wood.
- 10. DO NOT MANUALLY STOP OR SLOW BLADE** after turning the saw off. Allow it to come to a complete stop before you leave it unattended.
- 11. ALL INSPECTIONS, ADJUSTMENTS, AND MAINTENANCE MUST BE DONE WITH THE POWER OFF** and the circuit breaker shut off. Wait for all moving parts to come to a complete stop.
- 12. HABITS – GOOD AND BAD – ARE HARD TO BREAK.** Develop good habits in your shop and safety will become second-nature to you.
- 13. IF AT ANY TIME YOU ARE EXPERIENCING DIFFICULTIES PERFORMING THE INTENDED OPERATION, STOP USING THE BANDSAW!** Then contact our service department or ask a qualified expert how the operation should be performed.
- 14. MAKE SURE BLADE IS PROPERLY TENSIONED BEFORE OPERATING MACHINE.**
- 15. KEEP LOOSE CLOTHING AND LONG HAIR AWAY FROM MOVING CONVEYORS!**

WARNING

Like all machines there is danger associated with the Model G0504. Accidents are frequently caused by lack of familiarity or failure to pay attention. Use this machine with respect and caution to lessen the possibility of operator injury. If normal safety precautions are overlooked or ignored, serious personal injury may occur.

CAUTION

No list of safety guidelines can be complete. Every shop environment is different. Always consider safety first, as it applies to your individual working conditions. Use this and other machinery with caution and respect. Failure to do so could result in serious personal injury, damage to equipment, or poor work results.

WARNING

Additional Safety Instructions for Hydraulics

1. BE FAMILIAR WITH THE HAZARDS OF HYDRAULIC INJECTION INJURIES.

- Leaking hydraulic fluid may have enough pressure to penetrate skin. Never use your hands to check for suspected hydraulic leaks.
- Hydraulic fluid that is injected into skin is a medical emergency that may cause infection, disability, amputation or death.
- The average injection injury may be a small wound that has barely broken the skin. DO NOT be fooled by this type of injury. Immediately get to an emergency medical facility!
- Minimizing the time between the injury and when the injected material is removed is critical to minimizing the seriousness of the injury.

2. USE A PIECE OF CARDBOARD TO CHECK FOR SUSPECTED HYDRAULIC LEAKS.

Pressurized hydraulic fluid may cause injection injuries and can be extremely hot. Never use your hands to check for suspected hydraulic leaks.

3. PROTECT YOUR EYES AROUND HYDRAULIC SYSTEMS.

Safety glasses may not always protect your eyes from hot, pressurized fluid. The best way to protect yourself is to stay away from leaks until you can depressurize the system.

4. STOP THE MACHINE IF YOU NOTICE A HYDRAULIC LEAK.

Allowing the machine to continue running with a leak may increase the hazard of the situation.

5. DEPRESSURIZE THE HYDRAULIC SYSTEM BEFORE ATTEMPTING TO ADJUST ANY HYDRAULIC LINES OR FITTINGS.

Stop the resaw, open the conveyor speed valves, and make sure the pressure gauge reads 0 PSI.

6. DEPRESSURIZE THE HYDRAULIC SYSTEM BEFORE ATTEMPTING ANY MAINTENANCE OR SERVICE.

Stop the resaw, open the conveyor speed valves, and make sure the pressure gauge reads 0 PSI.

7. REGULARLY INSPECT AND PERFORM THE PROPER MAINTENANCE ON THE HYDRAULIC SYSTEM.

A well-maintained hydraulic system will have much fewer problems and hazards than a neglected system.

8. MAKE SURE ANY HYDRAULIC SYSTEM MAINTENANCE IS PERFORMED IN A CLEAN AND DUST-FREE WORK AREA.

Remove any sawdust, grime or water from hydraulic system openings or components before maintenance. Always use lint-free rags when wiping components.

9. ONLY USE HIGH PRESSURE HYDRAULIC HOSE AND STEEL HYDRAULIC FITTINGS WHEN REPLACING COMPONENTS IN THE HYDRAULIC SYSTEM.

DO NOT use brass or aluminum.

SECTION 3: CIRCUIT REQUIREMENTS

3-Phase Power

! WARNING

Serious personal injury could occur if you allow power to the machine before completing the setup process. **DO NOT** allow power to the machine until instructed to do so.

Amperage Draw

The Model G0504 features a 220/440V motors that are prewired for 220V and draw the following amps under full load:

Main Motor at 220V 72 Amps
Main Motor at 440V 41 Amps

Elevation Motor at 220V 2.2 Amps
Elevation Motor at 440V 1.1 Amps

Circuit Requirements

We recommend connecting your machine to a dedicated and grounded circuit that is rated for the amperage given below. Never replace a circuit breaker on an existing circuit with one of higher amperage without consulting a qualified electrician to ensure compliance with wiring codes. **If you are unsure about the wiring codes in your area or you plan to connect your machine to a shared circuit, consult a qualified electrician.**

Minimum 220V Circuit 90 Amps
Minimum 440V Circuit 60 Amps

! CAUTION

A fire may occur if your particular electrical configuration does not comply with local and state codes. The best way to ensure compliance is to check with your local municipality or a qualified electrician.

Connection Type

This machine is intended to be installed in a semi-permanent location and hardwired to the power source by a qualified electrician, using a supply circuit disconnect device with the capability of being locked in the **OFF** (open) position (see Figure 1).

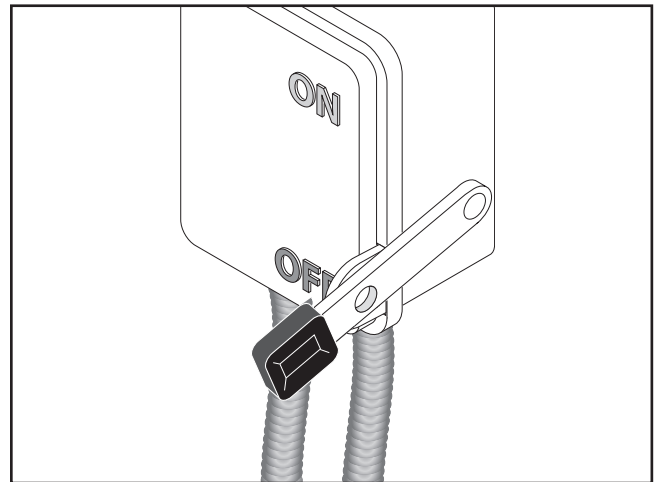

Figure 1. A power disconnect is preferable to high current plugs and receptacles.

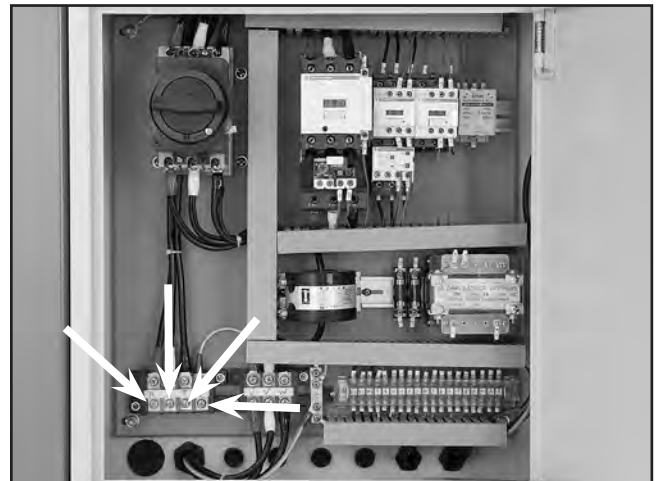
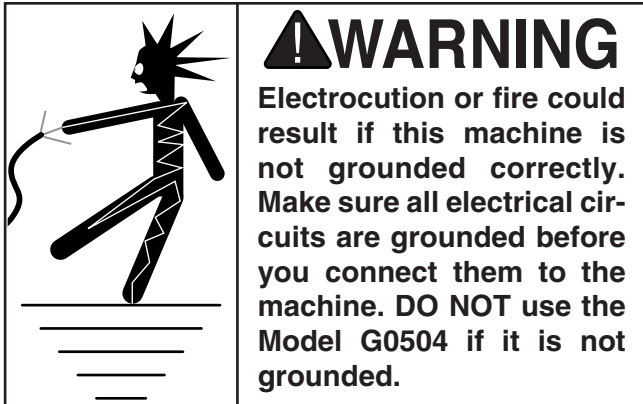

Figure 2. Power connection points inside the electrical box.



Grounding



In the event of an electrical malfunction or breakdown, grounding provides a path of least resistance for electric current to reduce the risk of electric shock. This machine must be equipped with an electric cord that has an equipment grounding conductor. This conductor must be grounded in accordance with all local codes and ordinances.

Improper connections of the electrical-grounding conductor can result in the risk of electric shock. Check with a qualified electrician or one of our service personnel if the grounding instructions are not completely understood, or if you are in doubt as to whether the machine is properly grounded.



Converting to 440V

Converting the Model G0504 to 440V operation consists of 1) wiring the voltage transformer, 2) replacing the overload relays with those provided in the G0504 440V conversion kit, and 3) rewiring the main motor and the elevation motor. A qualified electrician must inspect all electrical modifications before connecting to power.

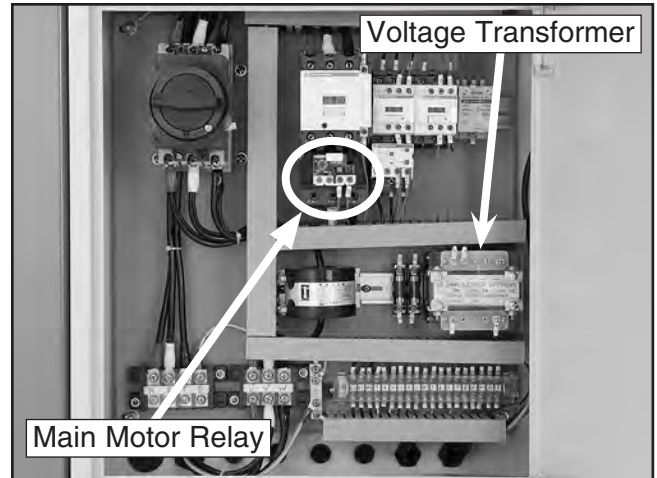

Figure 3. Inside of electrical box.

To convert the Model G0504 to 440V:

1. **Disconnect the resaw from the power source!**
2. At the voltage transformer, move the T1 wire from the 220V terminal to the 440V terminal.

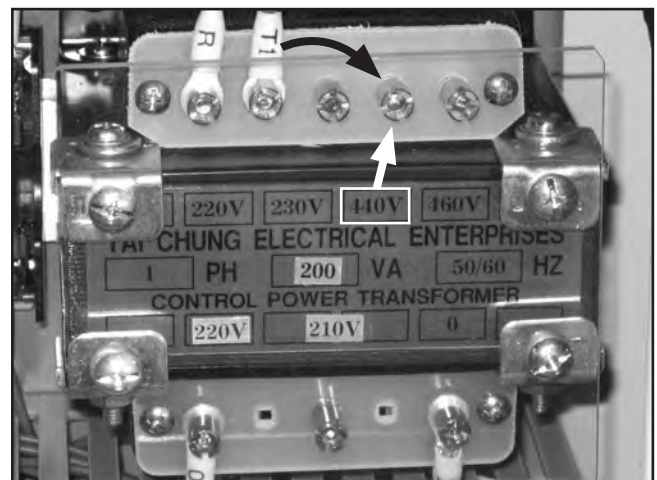

Figure 4. Location on voltage transformer to move the T1 wire for 440V operation.

3. Remove the wiring box covers on the main motor and elevation motor.
4. Wire the main motor and elevation motor as shown on the diagrams on the inside of each motor wiring box cover. (The circled references on the diagrams represent labels on the wires.)

Note: *Figures 5 & 6 below have been provided for your reference and are current at the time that this manual was written. However, always use the diagram on the wire cover that comes with your motor! Also, the electrical system on this machine is setup for the "RUN" diagrams shown on the wire cover. Ignore the "START" diagrams for this machine.*

5. Replace the main motor relay (LR3D-3363 63/80A) with the relay from kit (LR3D-3357 37/50A) and set the dial to "47."
6. Set the dial on the elevation motor relay to "1.5."
7. Replace any wire duct covers and motor wiring box covers you might have removed during this procedure, and close the electrical box door.

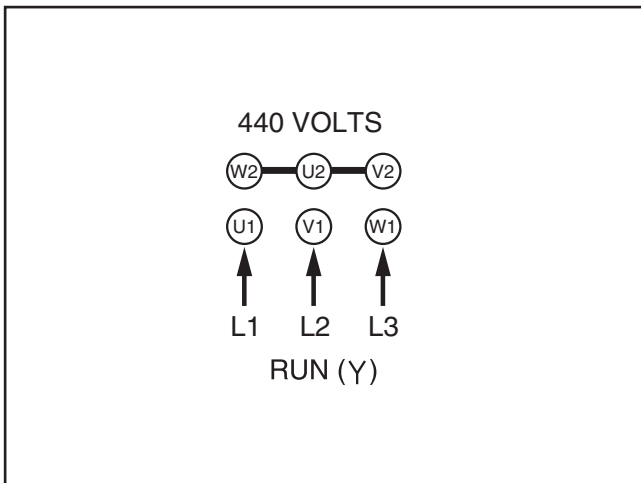
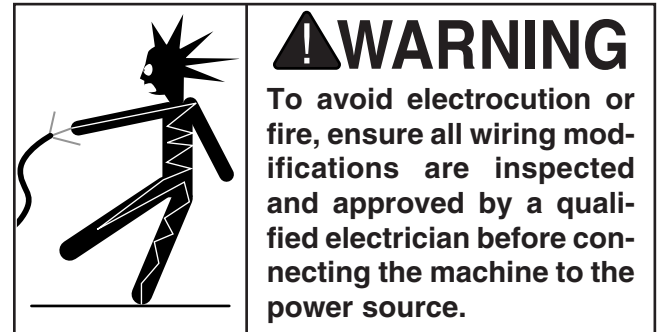

Figure 5. 30 HP main motor 440V wiring.

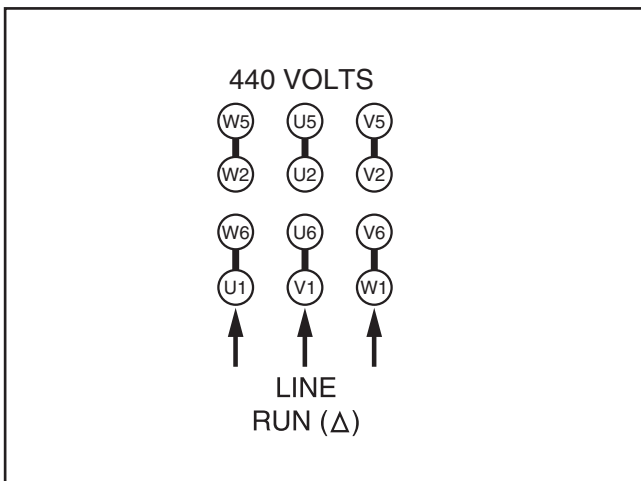

Figure 6. 1/2 HP elevation motor 440V wiring.



SECTION 4: MACHINE FEATURES

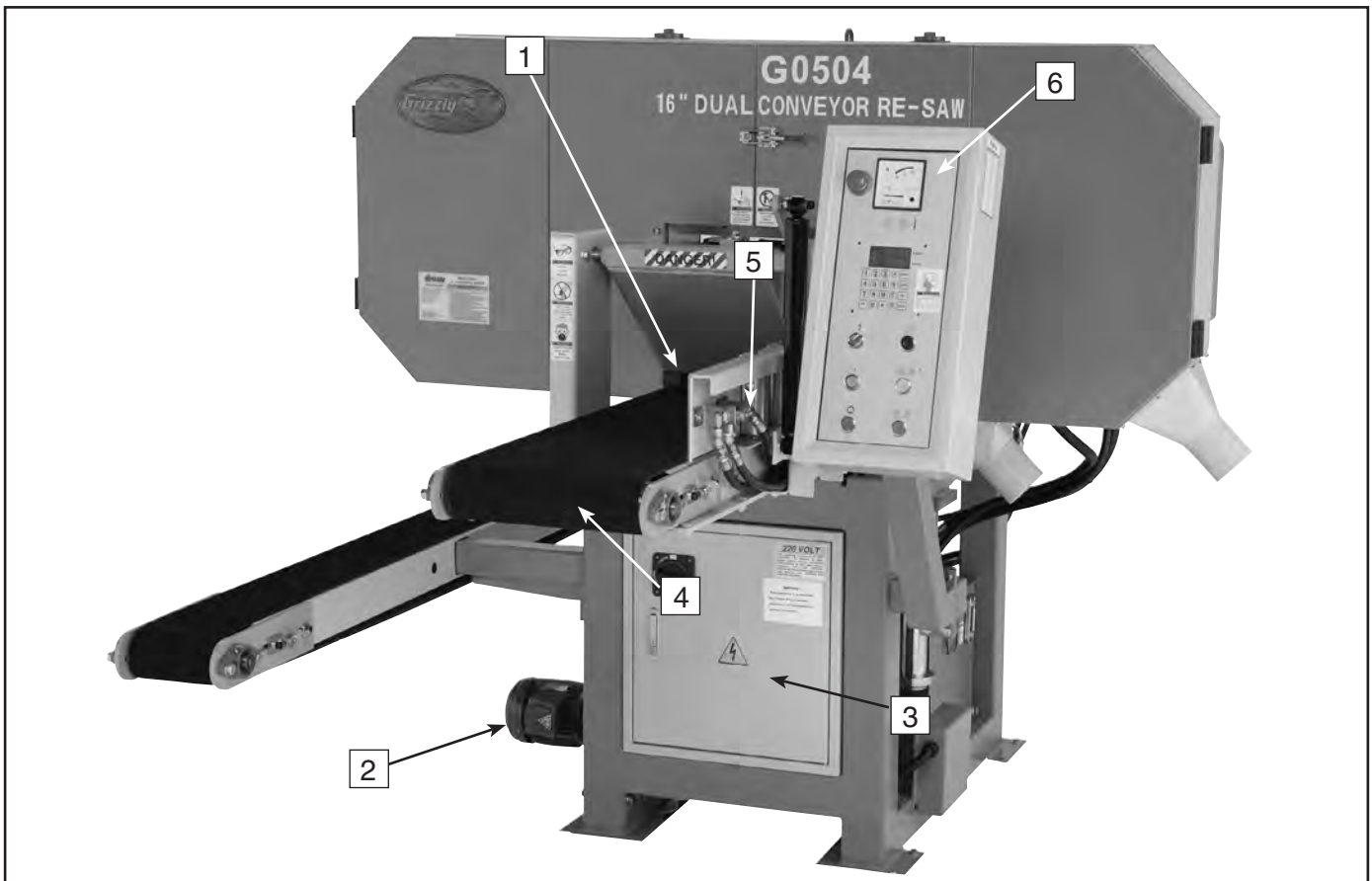

Figure 7. Main view of machine features and controls.

Main Features

- 1. Infeed Pressure Rollers**—Maintain downward pressure on the board to keep it sturdy during cutting.
- 2. Head Elevation Motor**—Responsible for moving the head (the part of the saw that contains the wheels and blade) up or down as needed.
- 3. Electrical Control Box**—Main area for wiring, rewiring, and changing the fuses. Should never be opened when the machine is connected to the power source!
- 4. Infeed Conveyor**—Moves the board through the bandsaw blade during cutting.
- 5. Infeed Conveyor Engagement Lever**—Allows the operator to stop and start the infeed conveyor while the blade is moving.
- 6. Control Panel**—The part of the resaw where the operator can control the starting and stopping of the motor, the various height changes, and the calibration of the blade height to the conveyor. The control panel also houses a load meter that allows the operator to monitor the load being placed on the resaw during operation. For more details, see **Page 14**.

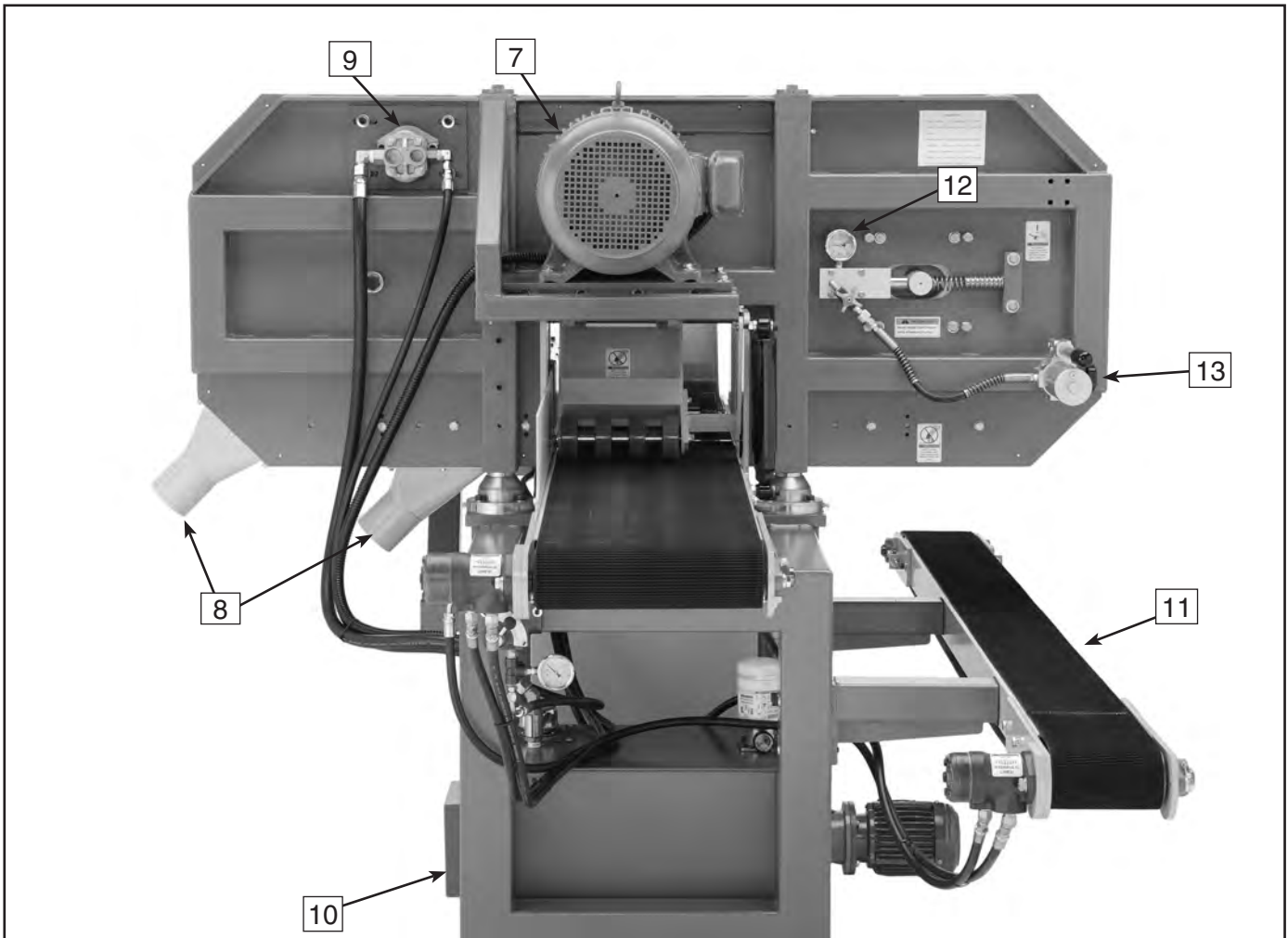

Figure 8. Rear view of machine features and controls.

- 7. Main Motor**—Powers the saw wheels for blade movement and drives the hydraulic pump for conveyor movement.
- 8. Dust Ports**—Allows the resaw to be connected to a dust collection system.
- 9. Hydraulic Pump**—Creates hydraulic oil flow which drives the conveyor motors.
- 10. Hydraulic Tank**—Holds and cools the hydraulic fluid for the hydraulic system.

- 11. Return Conveyor**—Allows the person receiving the newly cut board to return it to the operator without walking around the saw.
- 12. Blade Tension Gauge**—Shows the current blade tension.
- 13. Blade Tensioner**—Provides hydraulic blade tension and easy tension release.



Control Panel

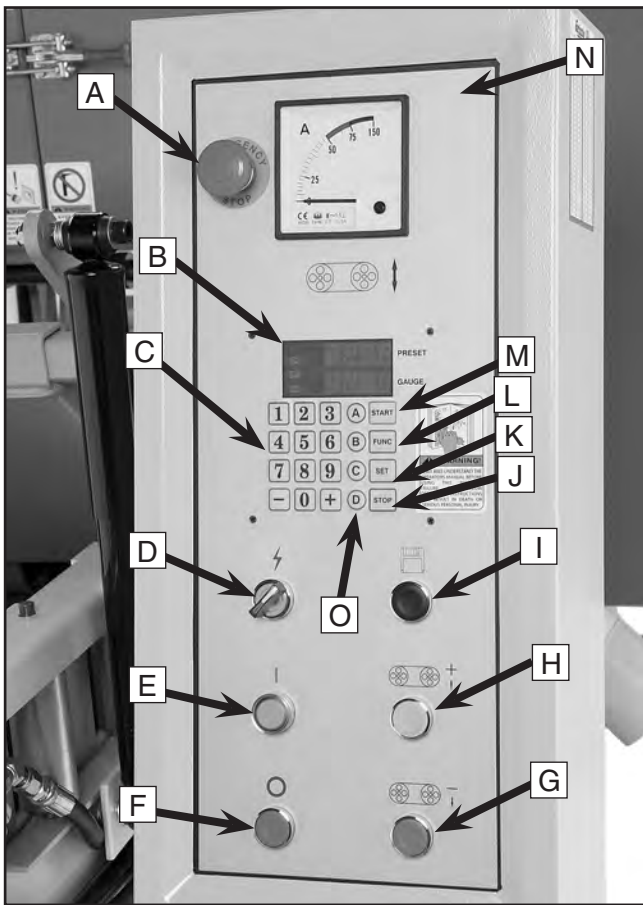

Figure 9. Control panel close-up.

- A. **EMERGENCY STOP Button**—Cuts power to the main motor to stop the blade and hydraulic pump. (*Caution—It takes approximately 30 seconds for the blade to come to a complete stop.*)
- B. **Display**—Shows the distance from the conveyor belt to the blade. Also used to enter and change settings, move blade height, and program the memory function.
- C. **Keypad**—Inputs height values. The + and - keys manually jog the height up or down.
- D. **POWER ON Switch**—Engages power to the control panel.
- E. **MOTOR START Button**—Starts the main motor, which is responsible for the blade and conveyor movement.

- F. **MOTOR STOP Button**—Stops the main motor, blade, and conveyors.
- G. **DOWN Button**—Moves the head (blade) down toward the infeed conveyor.
- H. **UP Button**—Moves the head (blade) up toward the infeed conveyor.
- I. **Memory Button**—Moves blade to a preset height change. For example, if you want to produce multiple $\frac{1}{4}$ " boards from a 5" board, you can set the memory to X inches ($X = \frac{1}{4}$ " + your blade kerf). After every cut, the head will automatically move down X inches when you press the memory button. You can then repeat this procedure until the 5" board is reduced to the last $\frac{1}{4}$ " that can be cut from that board.
- J. **STOP Key**—Stops the elevation motor from its current movement.
- K. **SET Key**—Calibrates the height of the blade from the table, or can be used in combination with the *FUNC* key to set the memory.
- L. **FUNC Key**—Prepares the control panel for special functions. Can be used in combination with the *START* key to manually type in a numeric height on the keypad, or can be used in combination with the *SET* key to set the memory.
- M. **START Key**—Moves the blade to the height that is entered in the keypad. Must be used in conjunction with the *FUNC* key.
- N. **Load Meter**—Displays the current load placed on the machine. The load meter is used to determine the appropriate conveyor feed rate for each species of wood and each blade being used.
- O. **Memory Preset Keys (A, B, C, D)**—Allows multiple dimension sizes to be saved and recalled. For example, if you have 500 pieces to resaw and the starting size is 2" thick on all of them, then you can save 2" in the A memory key. After cutting down each piece, press A to return to the starting height.



SECTION 5: SET UP

About this Section

The purpose of this section is to guide you through the required steps to get your machine out of its crate and into operating condition.

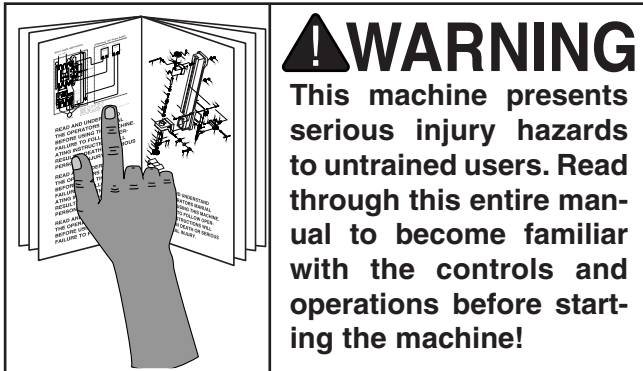

Unpacking

The Model G0504 is shipped from the manufacturer in a carefully built crate. If you discover the machine is damaged after you have signed for delivery, *please immediately call Customer Service at (570) 546-9663 for advice.*

Save the containers and all packing materials for possible inspection by the carrier or its agent. *Otherwise, filing a freight claim can be difficult.*

When you are completely satisfied with the condition of your shipment, you should inventory the equipment from the shipping crate.



Piece Inventory

After all the parts have been removed from the shipping crate, you should have:

- Resaw Bandsaw Machine
- Bandsaw Blade 180" x 1" x 0.035"
- Tool Box
- T-Handle Wrench 19mm
- 7 pc. Combination Wrench Set —10, 12, 13, 14, 17, 19, 21 mm
- 7 pc. Hex Wrench Set —2.5, 3, 4, 5, 6, 8, 10 mm
- Phillips Head Screwdriver
- Flat Head Screwdriver
- Adjustment Wrench 30 x 32 mm

In the event that any non-proprietary parts are missing (e.g. nuts or washers), we would be glad to replace them, or for the sake of expediency, replacements can be obtained at your local hardware store.

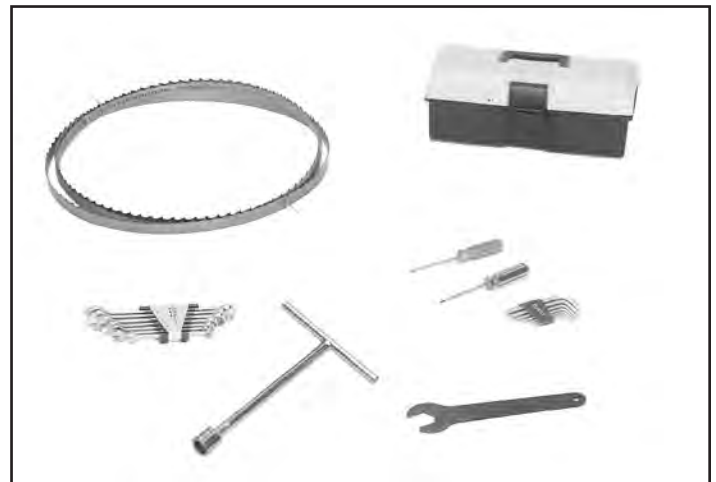
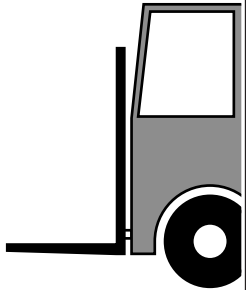

Figure 10. Piece inventory from packing crate.



Removing Resaw from Crate Pallet

	<p>⚠ WARNING</p> <p>The Model G0504 is a heavy machine that weighs approximately 3300 lbs. Serious personal injury may occur if safe moving methods are not followed. To be safe, you will need assistance and power equipment when moving the shipping crate and removing the machine from the crate.</p>
---	---

To remove the resaw from the crate pallet:

1. Remove the lag bolts from the stand feet that secure the resaw to the crate pallet.
2. Using a forklift, lift the resaw from the frame location shown in **Figure 11**, and move it to your predetermined location.

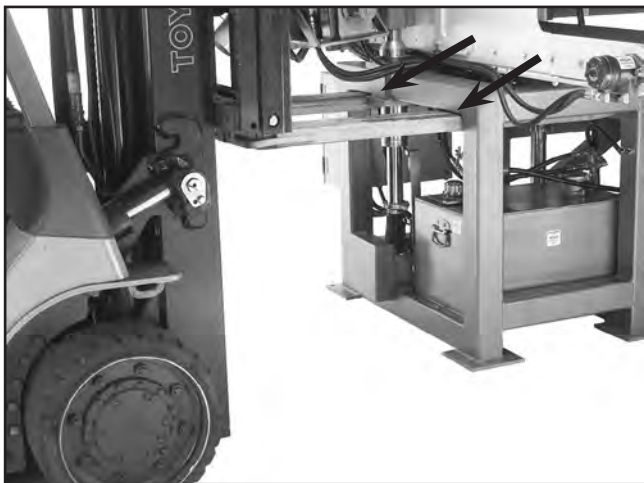

Figure 11. Lifting points for moving the resaw with a forklift.



Mounting Resaw to the Floor

Although not required, we recommend that you mount your new machine to the floor. Because this is an optional step and floor materials may vary, floor mounting hardware is not included.

Bolting to Concrete Floors

Lag shield anchors with lag bolts and anchor studs (**Figure 12**) are two popular methods for anchoring an object to a concrete floor. We suggest you research the many options and methods for mounting your machine and choose the best that fits your specific application.

NOTICE

Anchor studs are stronger and more permanent alternatives to lag shield anchors; however, they will stick out of the floor, which may cause a tripping hazard if you decide to move your machine.



Figure 12. Typical fasteners for mounting to concrete floors.



Installing & Tensioning Blade

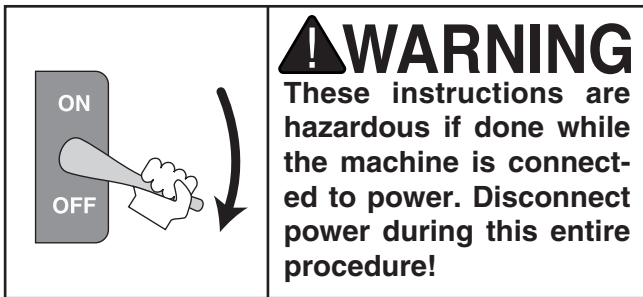

Blade installation can be done by one person but is easiest if done with two people.

To install and tension the blade:

1. Put on safety glasses and heavy leather gloves.
2. Open the wheel cover to gain access to the wheels.
3. Hold the blade from each side, and position it in front of the wheels so the blade teeth are facing the front of the machine.
4. Carefully fit the blade over each wheel, and position it between the blade guides as shown in **Figure 13**. Make sure the teeth point toward the right-hand side of the machine, as you are facing the front.

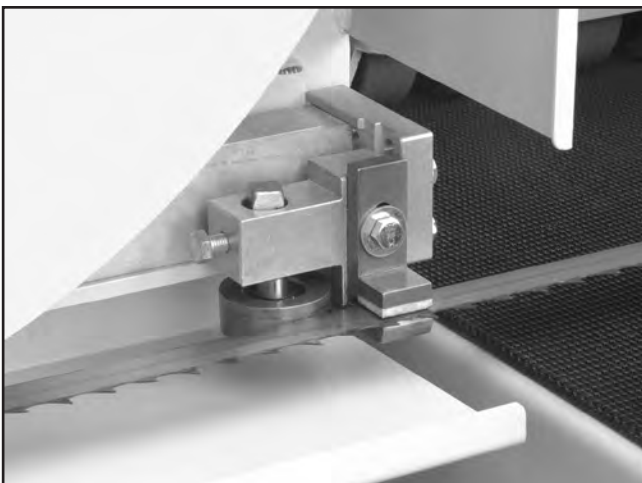

Figure 13. Blade positioned between blade guides.

5. Position the blade on the wheels so that the tooth gullet is approximately $\frac{1}{16}$ " over the edge of the wheel, as shown in **Figure 14**. Also, see the blade illustration in **Figure 15** for more details.



Figure 14. Blade positioned on wheel.

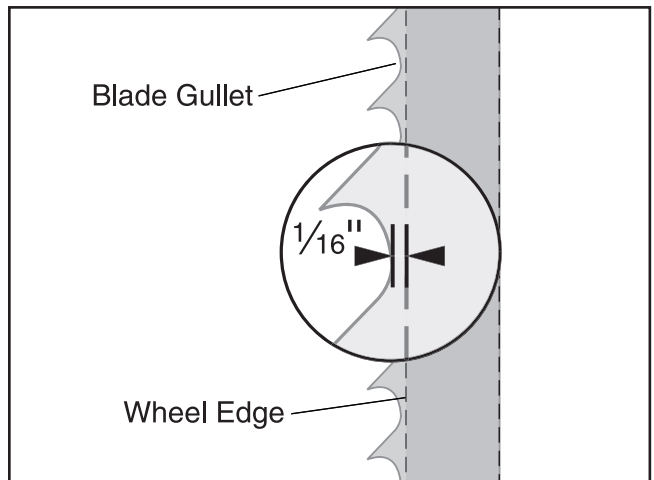

Figure 15. Illustration of proper blade position.

6. Loosen the stop valve (**Figure 16**) and tighten the pump valve.
7. Tighten the blade with the blade tensioner shown in **Figure 16**. Use the colored area on the tension gauge as a proper tension guide for your specific blade material.

Carbon SteelYellow
 Bi-metal Orange

Note—Always adjust the pressure to the lowest rating of each colored area and then increase tension as needed (blades stretch as they warm up).

8. Tighten the stop valve and loosen the pump valve.

Note—To loosen the blade tension, loosen the stop valve.

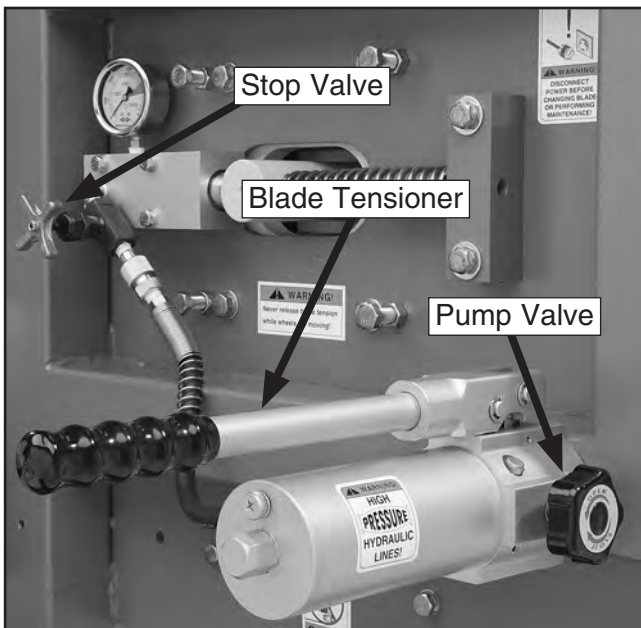

Figure 16. Blade tensioner controls.

NOTICE

Always de-tension blade after use.



Adjusting Blade Guides

Each blade guide assembly consists of **Guide Blocks** and a **Support Bearing**.

The blade guides keep the blade stable during operation, so make sure they are properly adjusted before starting the bandsaw.

	<p>! WARNING These instructions are hazardous if done while the machine is connected to power. Disconnect power during this entire procedure!</p>
--	--

Guide Blocks

Each guide block consists of an upper and lower ceramic block that stabilizes the blade from up/down movement during operation.

The lower block is designed to remain in a fixed position, and the upper block is designed to be adjusted during each blade change. When the machine is new, the lower block is set at the factory and should not need to be adjusted (see *Section 8: Service Adjustments* for more information about the lower guide). The upper block, however, should be adjusted every time you install a new blade or re-install an old blade.

To adjust the upper guide block:

1. Loosen the guide block adjustment bolt shown in **Figure 17**.

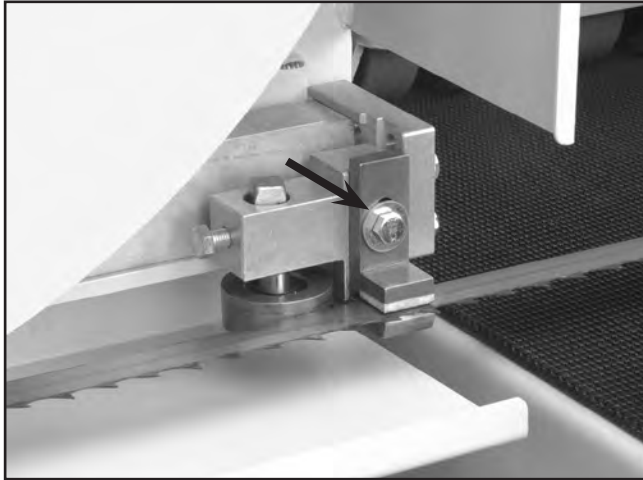

Figure 17. Guide block adjustment bolt.

2. Slide the upper guide block up, place a dollar bill (as a quick gauge for 0.004" clearance) underneath the upper guide block, then let the upper guide block slide down to sandwich the dollar between the blade and the upper guide block as shown in **Figure 18**.



Figure 18. Dollar bill between upper guide block and blade.

3. Keep the dollar bill in place and tighten the upper guide block.
4. Remove the dollar bill.
5. Repeat **Steps 1-4** with the blade guide on the other side of the conveyor.

Support Bearing

The support bearing is positioned behind the blade to brace it from pushing backwards during a cut. **Figure 19** shows the support bearing components to clarify the adjustment instructions.

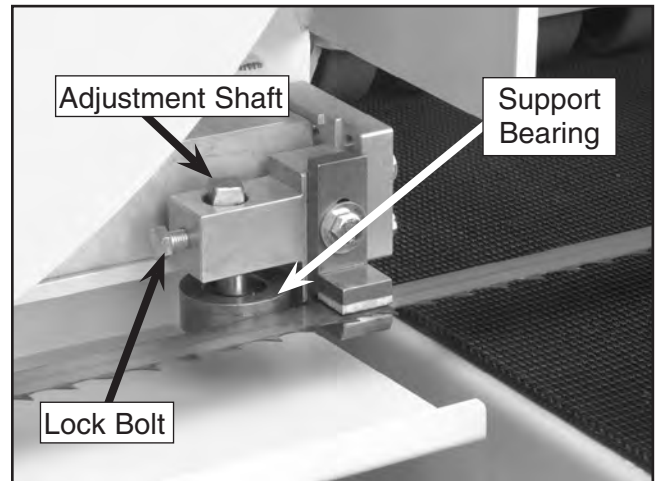

Figure 19. Support bearing components.

To adjust the support bearings:

1. Loosen the lock bolt approximately $\frac{1}{4}$ turn. Note—*If you loosen the lock bolt too much, the support bearing will fall out of place.*
2. Turn the adjustment shaft until the support bearing is positioned approximately 0.016" behind the back of the blade. Use a feeler gauge or four thicknesses of a dollar bill to check this.
3. Tighten the lock bolt, and repeat with the other support bearing.
4. Test the adjustment of the support bearings by spinning the wheels by hand, at full blade tension, in the same direction of operation. While you are spinning the wheels, the support bearings should not turn. (The support bearings should only turn during cutting operations.)



Connecting to Dust Collector

To be effective, the dust collection system that you connect to the resaw must be able draw a combined total of at least 1000 CFM at the dust ports. Note—*This number is an approximation and has been provided for estimation purposes only.*

To connect the resaw to a dust collector:

1. Attach two 4" dust hoses to the dust ports as shown in **Figure 20**, and be sure to tighten the hose clamp to ensure a snug fit.

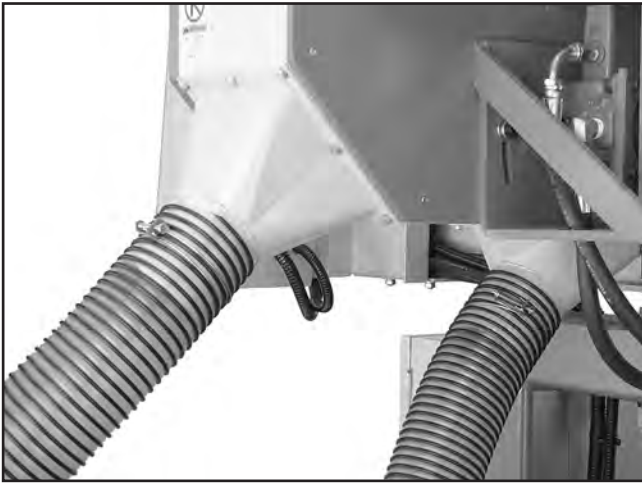

Figure 20. Dust hose connected to dust port.



Connecting to Power Source

If you have performed all of the previous set up instructions, the resaw can now be connected to the power source by a qualified electrician.



Test Run

!WARNING

Before starting the resaw, make sure you have performed the preceding assembly and adjustment instructions, and you have read through the rest of the manual and are familiar with the various functions and safety issues associated with this machine. Failure to follow this warning could result in serious personal injury or even death!

To test run the resaw:

1. Make sure the wheel cover and electrical box is closed and all tools or other objects are cleared away from the machine.
2. Put on safety glasses and make sure any bystanders are out of the way and also wearing safety glasses.
3. Tension the blade.
4. Turn ON the master switch that is located on the outside of the electrical box.
5. Turn the *POWER ON* switch (shown in **Figure 21**) clockwise.



Figure 21. *POWER ON* switch.

6. Press the *UP* and *DOWN* buttons to make sure the resaw head moves in the proper direction.

— If the resaw head moves in the opposite direction as indicated, then the machine has been wired out of phase. To correct this, disconnect the power to the machine, open the electrical box, and switch any two current carrying wires (R, S, or T) that connect the machine to the power source.

7. Push the emergency stop button in, then twist it clockwise until it pops out.

8. Once you have performed **Steps 1-4** and everything is okay with the machine and set up, press the *MOTOR START* button. As you are standing in front of the machine, make sure that the blade is moving from left to right.

9. Press the conveyor lever forward to test the conveyor belt.

— If any problems occur, press the *EMG STOP* button. Investigate and correct the problem before operating the machine further. If you need help, refer to the troubleshooting section in the back of this manual.

— If you cannot easily locate the source of an unusual noise or vibration by yourself, please contact our service department at (570) 546-9663.



SECTION 6: OPERATIONS

Operation Safety

All operators of this machine must be familiar with the **Section 2: Safety** before operating this machine. However, no safety list can cover every hazard for every working environment, so common sense must be used at all times in all situations.

⚠️ WARNING

Damage to your eyes, lungs, and ears could result from failure to wear safety glasses, a dust mask, and hearing protection while using this machine.

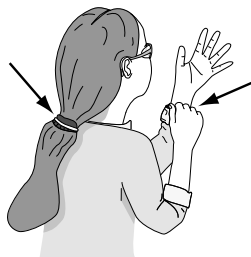
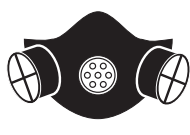

⚠️ WARNING

Loose hair and clothing could get caught in machinery and cause serious personal injury. Keep loose clothing rolled up and long hair tied up and away from moving machinery.

NOTICE

The following section was designed to give instructions on the basic operations of this machine. However, it is in no way comprehensive of all of the machine's applications. **WE STRONGLY RECOMMEND** that you read books, trade magazines, or get formal training to maximize the potential of your machine.

Conveyor Controls

The Model G0504 features an infeed conveyor and a return conveyor. The speed and engagement controls of the conveyors are controlled by the conveyor control lever. The farther the control lever is pushed forward, the faster the conveyors will move.

To operate the infeed conveyor:

1. Read the subsection titled "Control Panel" on **Page 14** to become familiar with the control panel functions.
2. With the saw running, push the infeed conveyor engagement lever (**Figure 22**) forward to engage the conveyor belts. Push the lever farther forward to make the conveyors run faster, or pull the lever backwards to make the conveyors run slower. Pull the lever all the way back to stop the conveyors.

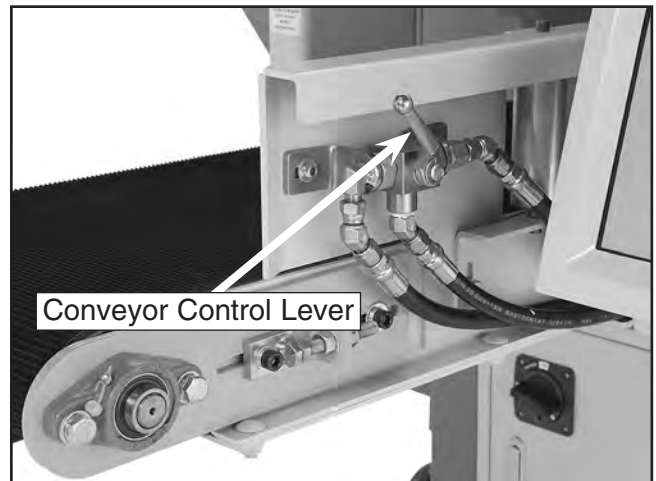

Figure 22. Conveyor controls.

Setting Blade Height

The blade height is defined as the distance between the conveyor table and the bottom face of the bandsaw blade. There is an internal limit switch that will not allow the blade to be adjusted closer than $\frac{1}{4}$ " to the conveyor table. Note—*Use the "Blade Memory Function" described in the next subsection when you want to make resaw cuts thinner than $\frac{1}{4}$ ", and be sure to cut from the top of the workpiece.*

The blade height can be adjusted by using the keypad, or by pressing the *UP* and *DOWN* control panel buttons. After using either method of adjustment, the digital display will indicate the current blade height.

To set the blade height with the *UP* and *DOWN* control panel buttons:

1. Turn the control panel *POWER ON* switch clockwise to supply power to the control panel.
2. Press the *UP* button to move the blade up and press the *DOWN* button to move the blade down. Watch the digital display to gauge the blade height.

To set the blade height with the keypad:

1. Turn the control panel *POWER ON* switch clockwise to supply power to the control panel.
2. Press the *FUNC* key.
3. Enter the desired blade height to the nearest hundredth's place. For example, if you want the blade height to be 2", press *2, 0, 0* on the keypad. If you want the blade height to be $\frac{3}{4}$ ", press *7, 5*.
4. After the blade height has been entered, press the *START* key.



Calibrating Digital Display

The digital display indicates the distance between the conveyor table and the bottom face of the bandsaw blade. The digital display needs to be calibrated to ensure that the displayed blade height and the actual blade height are the same.

To calibrate the digital display:

1. Resaw a piece of scrap wood. See "Resawing" on **Page 27** for more information.
2. Measure the thickness of the workpiece that was cut off between the conveyor table and the blade. Note—*Use a precise measuring tool such as calipers or a micrometer.*
3. Press the *SET* key.
4. Enter the thickness value of the cut-off piece measured in **Step 2**. For example, if the thickness is 1", press *1, 0, 0* on the keypad.
5. Press and hold the *SET* key for approximately 5 seconds or until the display stops flashing.

The digital display is now calibrated and all blade height values displayed will be the same as the actual distance between the conveyor table and the bottom face of the bandsaw blade.



Setting Memory Button

The blade memory button lowers the blade a pre-determined distance each time it is pressed. This allows you to make a series of cuts from the top side of the workpiece, all of the same thickness.

Be sure to add the blade kerf to the desired thickness of the cut-off pieces when setting the memory function. For example, if you want your cut-off pieces to be 1" thick and the kerf of the blade is 0.06", the memory function needs to be set to 1.06".

The blade memory function is also used when you want to make resaw cuts thinner than $\frac{1}{4}$ ". Because the blade cannot be adjusted closer than $\frac{1}{4}$ " to the table, resaw cuts thinner than $\frac{1}{4}$ " need to be cut from the top side of the workpiece.

To set the memory function:

1. Turn the control panel *POWER ON* switch clockwise to supply power to the control panel.
2. Press the *FUNC* key.
3. Enter the distance, to the nearest hundredth's place, that you want the blade to lower. For example, if you want the blade to lower 2.06", press 2, 0, 6 on the key pad. If you want the blade to lower 0.56", press 5, 6.
4. Press and hold the *SET* key for approximately 5 seconds or until the display stops flashing.
5. Press the *MEMORY* button and the blade will automatically lower the distance set into the memory function.

Note—For best results, make a few cuts while using the MEMORY button, measure the workpiece, and adjust the memory setting according to the measurements of the cut-off workpiece.



Using Memory Preset Keys

The memory preset keys (*A, B, C, D*) allow four dimension sizes to be saved and recalled.

For example, if you have 500 pieces to resaw and the starting size is 2" thick on all of them, then you can save 2" in one of the memory keys. After cutting down each piece, press that memory preset key to return to the starting height of 2" for the next whole piece.

To store a height in the A memory preset key:

1. Press the *A* key. The current preset height flashes on the display.
2. Enter the height you wish to store. For example if you want to store 2" as the height", press 2, 0, 0 on the key pad.
3. Press and hold the *A* key for 3 seconds. The display zeros out and stops flashing.

To use the stored memory preset in the A key:

1. Press the *A* key. The current preset height flashes on the display.
2. Press the *START* key on the key pad. The blade moves to the stored height dimension.

Note—To stop a stored memory preset from moving to its stored height, press the STOP key on the key pad AFTER you have pressed the memory preset key (A in this example).



Resawing

To perform a resawing operation:

1. Make sure the blade is installed and tensioned correctly. See “Installing Blade” on **Page 19** for more information.
2. Make sure the blade is tracking correctly. See “Adjusting Blade Guides” on **Page 20** for more information.
3. Turn the control panel *POWER ON* switch clockwise to supply power to the machine.
4. Set the blade height at the control panel. See “Setting Blade Height” on **Page 25**. Note—*The accuracy of the blade height shown on the digital display can only be assured if the calibration process has been performed. See Page 25 for more information on calibrating the digital display.*
5. Press the *MOTOR START* button to start the bandsaw blade.
6. Push the infeed conveyor engagement lever forward to start the infeed conveyor. Turn the infeed conveyor speed dial counter-clockwise to increase the speed and clockwise to decrease the speed. See “Conveyor Controls” on **Page 24** for more information.
7. Recheck the blade tension.
8. Make sure the workpiece has two sides that are relatively flat and parallel with each other.
9. Begin feeding the workpiece under the front pressure rollers with the jointed edge against the guide rollers, as shown in **Figure 23**.

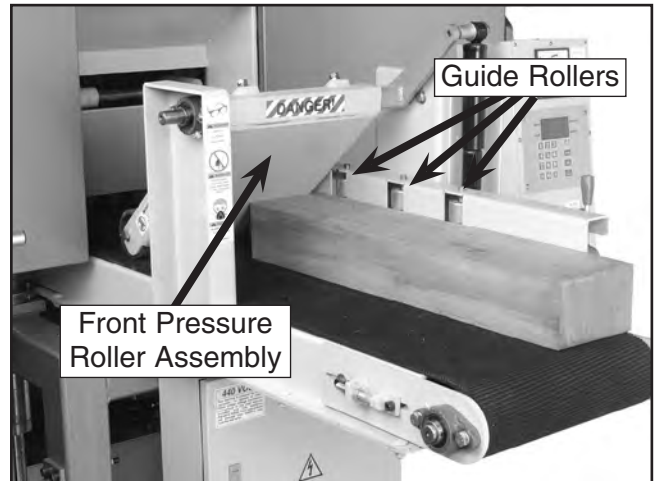

Figure 23. Feeding the workpiece through the bandsaw.

10. Watch the load meter (**Figure 24**) at the top of the control panel. The meter displays the amperage load that is being placed on the machine. Adjust the infeed conveyor feed rate until the meter reads between 25-30 Amps during the cutting operation.



Figure 24. Load meter.

11. Receive the workpiece on the outfeed side of the machine. Note—*If a second person is receiving the workpieces, use the return conveyor to send them back to the person on the infeed side.*

NOTICE

Always de-tension blade after use.



Blade Information

Blade choices are limited due to the specialized nature of the Model G0504. The only variables when selecting a blade are the type of cutting tooth and the number of teeth-per-inch (Tooth Pitch).

Blade Tooth Type

Carbon Steel—The least expensive type, carbon steel blades are adequate for most cutting applications; however, they dull quickly and for economical reasons they are usually replaced rather than resharpened.

Carbide-Tipped—The most expensive type, carbide-tipped blades are designed for continuous use in production shops. They hold a sharp edge longer than carbon steel and they can be resharpened many times before needing to be replaced.

Tooth Pitch (TPI)

Tooth pitch refers to the number of teeth-per-inch. The more teeth-per-inch, the smoother the resulting cut, but the feed rate must be relatively slow. The less teeth-per-inch, the rougher the resulting cut, but the feed rate can be set faster. Some trial and error may be necessary to find the right combination of cut quality, tooth pitch and feed rate.

Blade Care

The resaw blade is a delicate piece of steel that is subjected to tremendous strain. You can obtain longer use from the blade if you give it fair treatment and always use the appropriate feed rate for your operation.

A clean blade will perform much better than a dirty blade. A dirty blade passes through the cutting material with much more resistance than a clean blade. This extra resistance will also cause unnecessary heat. Maintain your blades with a cutting blade lubricant like SLIPIT® (Model G5562/3 in the Grizzly Catalog).

Blade Length

The required blade length for the Model G0504 is 180".

Blade Width

The required blade width for the Model G0504 is 1".

Blade Breakage

Blade breakage is unavoidable, in some cases, since it is the natural result of the peculiar stresses placed on the blade. Blade breakage is also due to avoidable circumstances, which is most often the result of poor care or judgement on the part of the operator when mounting or adjusting the blade or support guides.

The most common causes of blade breakage are:

- Not releasing blade tension after use.
- Faulty alignment or adjustment of the guides.
- Using a blade with a lumpy or improperly finished braze or weld.
- Feeding the workpiece too fast.
- Tooth dullness or absence of sufficient set.
- Excessive or too little blade tension.
- Running the bandsaw excessively when not resawing.

Blades Available from Grizzly

MODEL	TYPE	WIDTH	GAUGE	TPI
H4874	Carbon	1"	0.035"	1.3
H4875	Carbide Tip	1"	0.035"	2-3
H4876	Carbide Tip	1"	0.035"	3-4

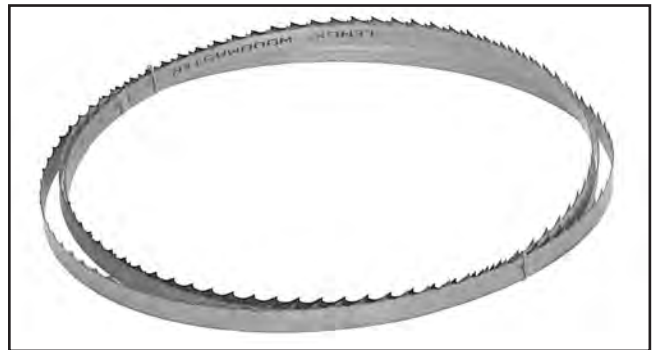

Figure 25. Lenox® bandsaw blade.



Accessories

H4959—Coolant Dispenser

Delivers a small amount of lubricant to the cutting surface to improve tool life and cutting efficiency. An absolute must for large resawing operations.



Figure 26. H4959 Coolant Dispenser.

G7984—Face Shield

H1298—Dust Sealed Safety Glasses

H1300—UV Blocking, Clear Safety Glasses

H2347—Uvex® Spitfire Safety Glasses

H0736—Shop Fox® Safety Glasses

Safety Glasses are essential to every shop. If you already have a pair, buy extras for visitors or employees. You can't be too careful when it comes to shop safety!



Figure 27. Our most popular safety glasses.

H6175—Power Respirator

H6892—3M Pre-Filter, 10-Pack

H6893—Filter Cartridge, 10-Pack

Say goodbye to foggy safety glasses and labored breathing, this battery powered respirator supplies a constant breeze of fresh air all day long. Comes with its own plastic case for clean, sealed storage. Finally, a respirator you can look forward to wearing—at an affordable price!



Figure 28. H6175 Power Respirator.

H0580—Pneumatic Grease Gun

Greasing fittings is a breeze with this pneumatic grease gun—and it's one of the most affordable on the market. Requires 90 PSI and consumes 4 CFM. Kiss that old hand pump grease gun goodbye!

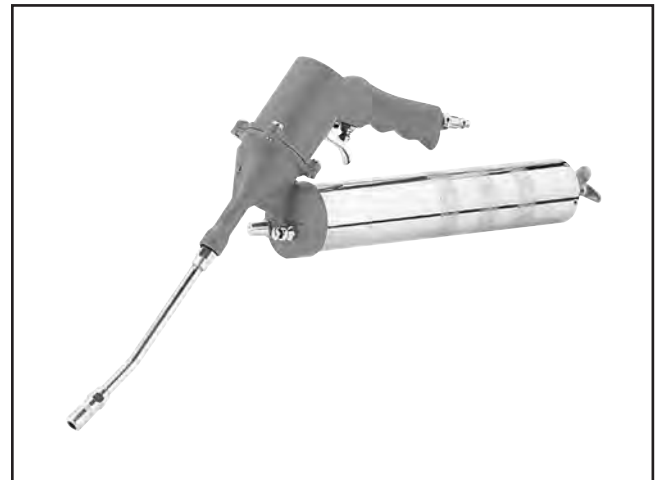
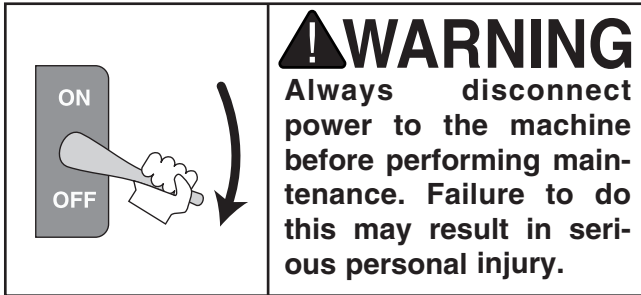

Figure 29. H0580 Pneumatic Grease Gun.

Call 1-800-523-4777 To Order

SECTION 7: MAINTENANCE



Cleaning

Inside Wheel Cover

To keep the bandsaw working properly, regularly open the wheel cover and vacuum sawdust.

Conveyor Belts

Use compressed air to clean the built-up sawdust from the conveyor belts. *Eye injuries frequently occur when cleaning with compressed air—wear safety glasses to protect yourself! Also wear a dust mask or respirator to protect your lungs from airborne dust particles.*

Elevation Columns

Use a dry rag to remove sawdust from the elevation columns and wipe them down with a light coat of oil.

Painted Surfaces

These areas may be cleaned with a dry or damp rag; however, make sure you DO NOT clean bare metal surfaces with a damp rag or they may rust.

Motor

Vacuum dust off of the motor on a regular basis. Built up dust acts as an insulator, making it difficult for the motor to dissipate heat.

Hydraulic Components

Keep hydraulic components free of sawdust, especially before working on them, to avoid contamination of the hydraulic system.



Miscellaneous

Always be aware of the condition of your machine. Routinely check the condition of the following items and repair or replace as necessary:

- Loose mounting bolts
- Worn switch
- Worn or damaged blade
- Worn or damaged support bearings or guide bearings



V-Belts

To ensure optimum power transmission from the motor to the blade and to the hydraulic pump, the V-belts must be in good condition (free from cracks, fraying and wear) and operate under proper tension. Check the V-belts at least every 3 months; more often if the bandsaw is used daily.

See *Section 8: Service Adjustments* for instructions on properly tensioning the belts or for replacing the belts, if needed.



Bearings

Except for the bearings that are fitted with grease fittings, the other bearings are sealed and pre-lubricated and require no lubrication during their usable life. All bearings are standard sizes, and replacements can be purchased from our parts department or a bearing supply store.



Grease Fittings

Wipe clean and lubricate the grease fittings with two pumps of high-temp bearing grease. The proper greasing intervals are indicated by the boxes on the chart below. Note—*This page was designed to be copied and used as a check-off chart to help maintain a regular lubrication schedule.*

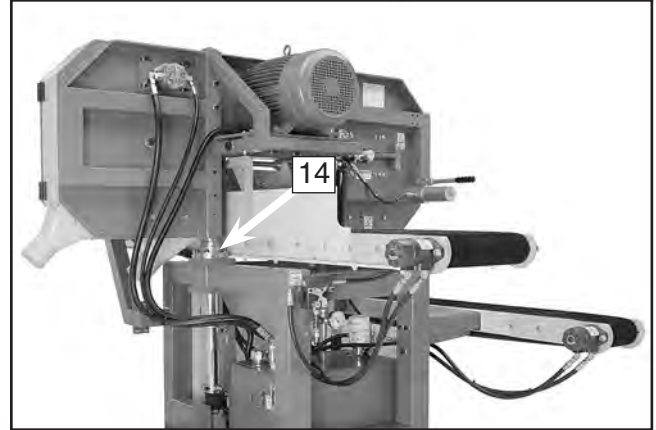
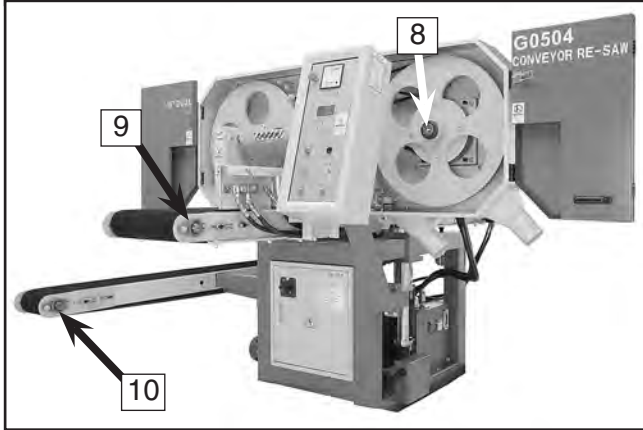
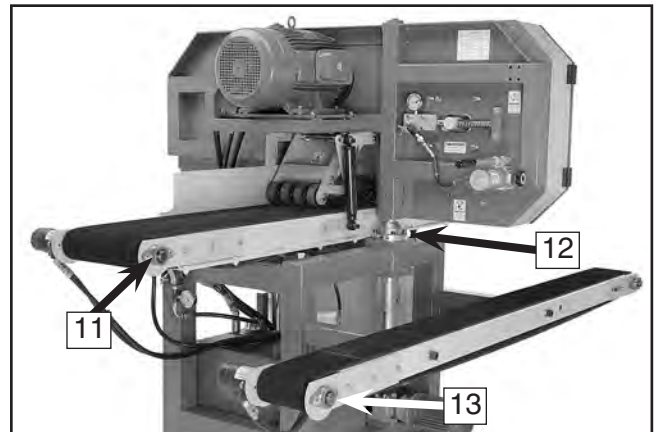
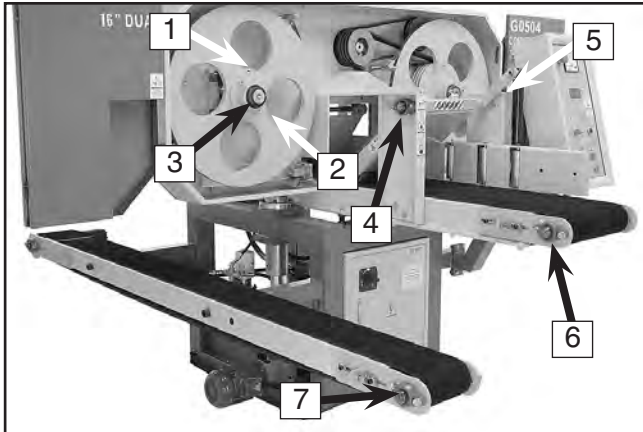

Check white boxes after lubricating fittings. Date Started:

G0504 GREASE SCHEDULE/CHECK-OFF CHART		HOURS OF USE					
MACHINE AREA	FITTINGS	160	320	480	640	800	960
		Main Wheels	3, 8				
Blade Tension Device	1, 2						
Main Conveyor	6, 9, 11						
Return Conveyor	7, 10, 13						
Elevation Columns	12, 14						
Pressure Rollers	4, 5						

Note — 160 hours is the equivalent of 1 month of regular use.

Hydraulic Fluid Schedule

Check the hydraulic fluid level daily.

The hydraulic system controls the movement of the conveyor belts. In order for this system to function properly and operate at the correct temperature, the hydraulic fluid level in the tank should be $\frac{2}{3}$ full between the fill lines on the fluid sight window, which is located on the front of the tank (see **Figure 30**).

To add hydraulic fluid, remove the breather cap shown in **Figure 30**. Use an ISO VG 10—Antiwear 10 Hydraulic Fluid or equivalent.

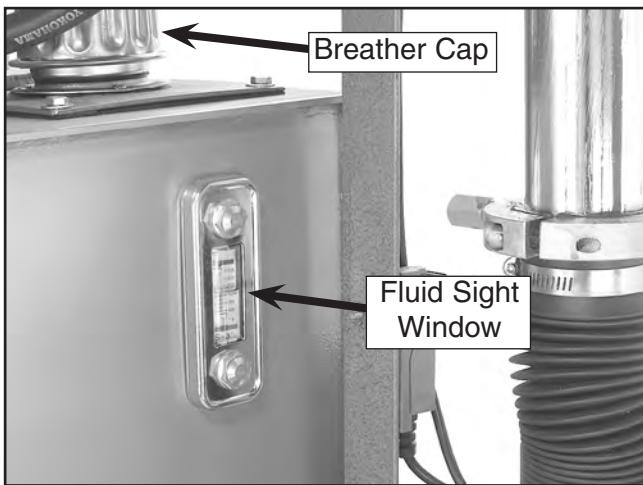

Figure 30. Hydraulic reservoir components.

Inspect and clean the breather cap and filler screen every 40 hours of regular use.

The breather cap is vented to allow the hydraulic system to breathe during operation. Below the breather cap is a plastic filler screen.

Visually inspect both the breather cap and the plastic filler screen. If there is visual contamination, clean both items with solvent and compressed air. Allow them to completely dry before installing back in the tank.



Hydraulic System Minor Service

The hydraulic system minor service consists of changing the fluid filter, cleaning the breather cap and filler screen, and inspecting the hydraulic fluid for signs of thermal breakdown, dust contamination, and water contamination.

Perform a “Minor Service” every 960 hours or every 6 months of regular use.

!WARNING

The hydraulic system on this machine creates very high pressure and the hydraulic fluid gets hot. Always stop the resaw, open the conveyor speed valves, make sure the pressure gauge reads 0 PSI, and make sure the fluid cools down before removing any lines or servicing the hydraulic system.

To change the filter:

1. Read and understand the hydraulic safety instructions on Page 6 before continuing!
2. Thoroughly clean the entire area around the filter to remove all dust. (Getting dust into the hydraulic system will contaminate it.)
3. Remove the filter by unscrewing it from the housing (**Figure 31**).



Figure 31. Removing filter.

4. Rub clean hydraulic fluid along the O-ring on the bottom of the new filter.
5. Thread the new filter into the filter housing and tighten by hand.

To inspect the hydraulic fluid:

1. Look at the color of the hydraulic fluid in the sight window.
 - If the fluid is milky in appearance, then the hydraulic fluid is contaminated with water. Repair leaks or fix the source of the problem and perform a major service.
 - If the fluid is dark brown or opaque, then the hydraulic fluid is severely contaminated or thermal breakdown has occurred. Correct the source of the contamination or which component is causing thermal breakdown, and perform a major service.
2. Smell the hydraulic fluid (remove breather cap).
 - If the fluid smells rancid or burnt, then thermal breakdown has most likely occurred. Correct the component that is causing thermal breakdown and perform a major service.

Hydraulic System Major Service

The hydraulic system major service consists of performing a complete “Minor Service,” draining the old hydraulic fluid, cleaning the tank screen, cleaning the tank, and adding new fluid.

!WARNING

The hydraulic system on this machine creates very high pressure and the hydraulic fluid gets hot. Always stop the resaw, open the conveyor speed valves, make sure the pressure gauge reads 0 PSI, and make sure the fluid cools down before removing any lines or servicing the hydraulic system.

The hydraulic tank, when filled correctly at the sight window, holds approximately 13.5 gallons of hydraulic fluid. Before draining the hydraulic fluid, make sure you have a drain pan that will hold that much fluid or make sure that you are prepared to drain the tank, plug the tank, empty your drain pan, drain the tank, and so forth.

To drain the hydraulic fluid:

1. **Read and understand the hydraulic safety instructions on Page 8!**
2. Place your drain pan under the drain plug (**Figure 32**) and remove the drain plug.

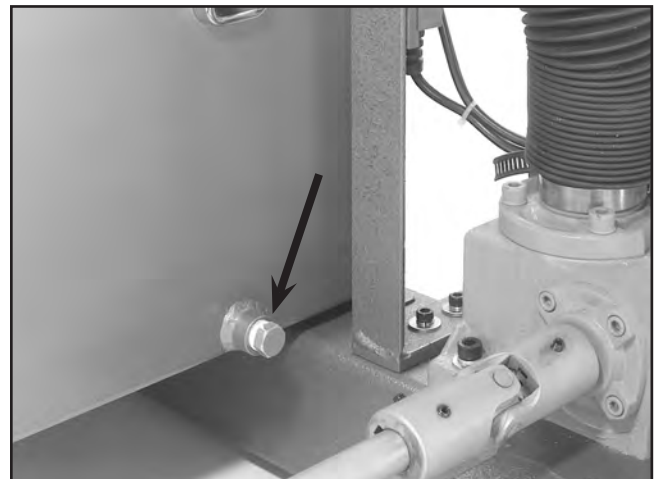

Figure 32. Drain plug for hydraulic tank.

3. Replace the drain plug after the hydraulic tank is completely drained.

To clean the tank screen:

1. Remove the access plate on top of the hydraulic tank as shown in **Figure 33**.

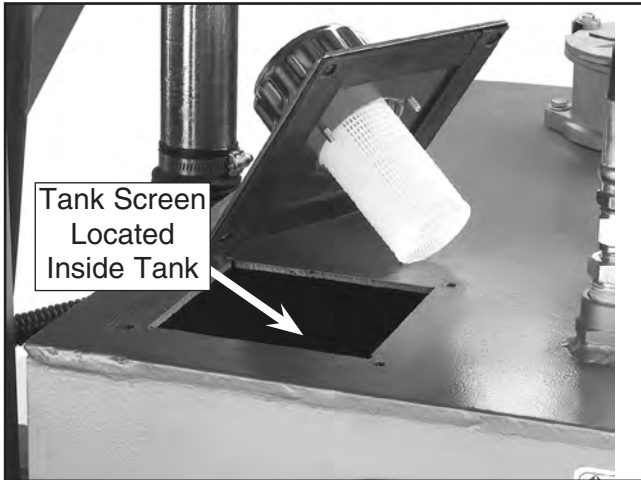

Figure 33. Access plate removed from tank.

2. Remove the tank screen, clean it with solvent and compressed air, and allow it to dry. (Re-install the tank screen **AFTER** you clean the bottom of the tank.)

To clean the bottom of the tank:

1. Use a lint free rag to wipe up and remove any sludge from the bottom of the tank.
2. Use clean hydraulic fluid on a clean rag to wipe up additional contaminants from the bottom and sides of the tank.
3. Replace the tank screen and access plate.

To fill the tank with new fluid:

1. Make sure that you have re-installed the tank screen, that the drain plug is tight, and that you have replaced the access plate on top of the tank.
2. Using an ISO VG 10—Antiwear 10 Hydraulic Fluid, fill the tank until the sight window is $\frac{2}{3}$ full between the hi and low marks on the sight window. *Note—This will take approximately 13.5 gallons.*



SECTION 8: SERVICE ADJUSTMENTS

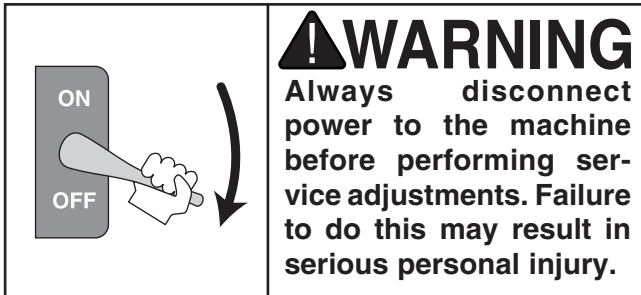

About Service

This section is designed to help the operator with adjustments that were made at the factory and that might also need to be made during the life of the machine.

This section is provided for your convenience—it is not a substitute for the Grizzly Service Department. If any adjustments arise that are not described in this manual, then feel free to call the Grizzly Technical Support at (570) 546-9663.



Adjusting Lower Blade Guides

The instructions on adjusting the upper guide blocks and support bearing are given in *Section 5: Set Up*. This section focuses on adjusting the lower blade guides, which is a non-routine adjustment that would typically be done before the upper blade guide and support bearing would be adjusted.

To adjust the lower blade guides:

1. Disconnect the resaw from the power source!
2. Open the wheel cover for easy access to the blade guide assemblies.
3. Make sure the blade is tensioned in the same manner that will be used for operation.
4. Loosen the lateral adjustment bolts (shown in **Figure 34**).

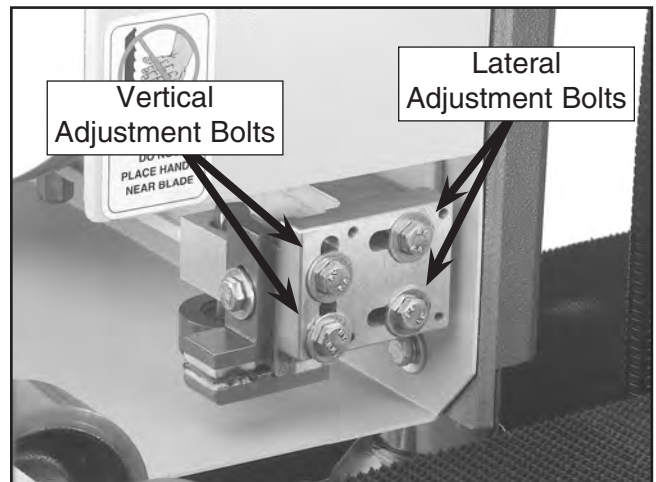

Figure 34. Lower guide block adjustment bolts.

5. Adjust the assembly so the blade guides are approximately $\frac{1}{16}$ " behind the gullets of the blade teeth, and tighten the lateral bolts.
6. Loosen the vertical adjustment bolts.
7. Adjust the lower blade guide so it barely touches the bottom of the blade, then tighten the vertical adjustment bolts.
8. Repeat **Steps 4-5** on the other blade guide.
9. Adjust the upper guide blocks and the support bearings.
10. Close the wheel cover.



Adjusting V-Belt Tension

Properly tensioned V-belts help the Model G0504 operate at its best. However, adjusting the V-belts is not an exact science and does require personal judgement. Adjusting the belts too loose will decrease the performance of the machine and adjusting the belts too tight may cause premature wear of the bearings and other components attached to the belts.

On the Model G0504 there is a triple-drive V-belt system that connects the motor to the wheel pulley and a single-drive V-belt system that connects the wheel pulley to the hydraulic pump (**Figure 35**).

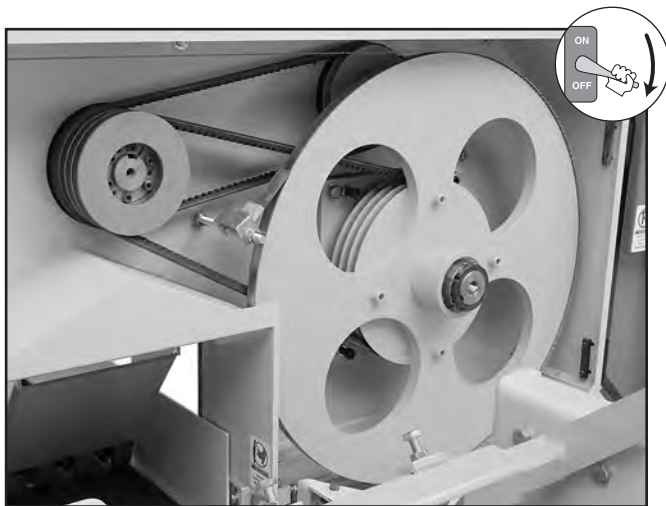

Figure 35. G0504 V-belts.

To adjust the V-belt tension for the saw wheels:

1. **Disconnect the resaw from the power source!**
2. Adjust the belt tension by using the motor mount hex bolts shown in **Figure 36**.
3. When the belts are properly tightened, lock the bolts in place with the jam nuts.

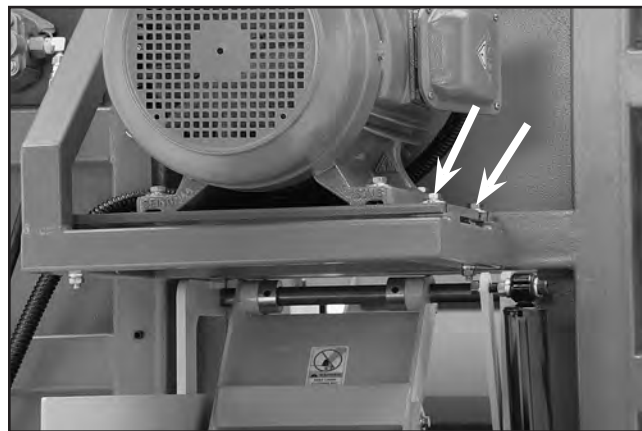

Figure 36. Large pulley cover attachment bolts.

To adjust the tension for the hydraulic pump V-belt:

1. Remove the small pulley cover from the pump seat.
2. Adjust the belt tension by loosening the cap screws shown in **Figure 37**.

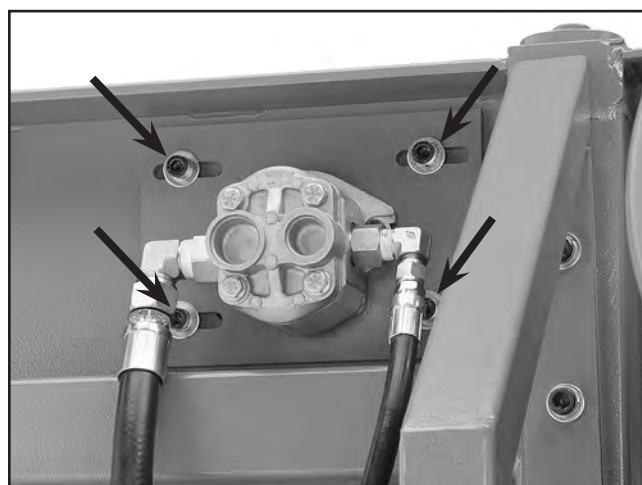

Figure 37. Pump seat cap screws.

3. Slide the pump left/right as needed until the belt has the proper tension.
4. Tighten the cap screws to lock the pump seat in place.



Replacing V-Belts

If the belts deteriorate or break, they will need to be replaced. When replacing one belt, you should replace all of them at the same time to ensure uniform belt tension and save time.

To replace the V-belts:

1. **Disconnect the resaw from the power source!**
2. Read the previous subsection titled “Adjusting V-Belt Tension” to become familiar with the V-belt tension controls.
3. Adjust the motor mount nuts down as far as they will go.
4. Remove all three V-belts that connect the motor to the wheel pulley. (The easiest way to take the belts on/off is to roll them on/off the pulley one at a time. The belts can then be fit over the wheel.)
5. Remove and replace the hydraulic pump V-belt. (Refer to Page 35 for information on how to loosen/tension this V-belt.)
6. Replace the three V-belts as a matching set. Matching sets can be identified by the batch number on the belt—NOT to be confused with the size markings of the belt.
7. Tension the newly installed V-belts.



Adjusting Main Conveyor Table

The main conveyor table height can be adjusted left-to-right and front-to-back to make the table parallel to the blade in both directions. This is an involved procedure that requires you to cut up a piece of test stock and make many repeat adjustments. Because of the complexity of this procedure, we will first give instructions on checking the table, so that you can be sure you need to perform the adjustment.

Before attempting these procedures, you need to have a perfectly squared up piece of stock that is as wide as possible and is at least two feet long. The wider the stock, the more accurate your procedure will be (we recommend using the maximum width that the resaw will allow). Also, you need to make sure that your blade is in good condition, the blade is tracked/tensioned properly and the blade guides are properly adjusted.

To check the main conveyor table alignment:

1. Cut a ¼" slice off of your squared-up test stock.
2. Using a dial caliper, measure the thickness of the cut piece at all four corners and in even locations along the edges of the stock. As you take these measurements, write them directly on the stock, near the location where you took the measurement (see **Figure 38**).

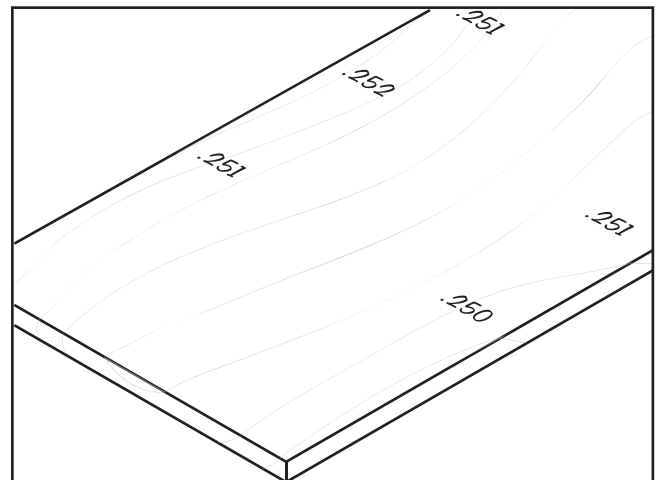

Figure 38. Test board with measurements.

3. Study the written measurements on your test piece. Note—*DO NOT place too much importance on the first and last six inches of the board, because the board will only have been under one pressure roller during that part of the cut.*

— If the measurements are more than 0.030" different from one side to the other, you should adjust the conveyor table.

To adjust the conveyor table:

1. **Disconnect the resaw from the power source!**
2. Use your test board to determine which direction the conveyor table needs to be moved. For example, if the right side of the board was thicker than the left side—you will need to move either the right side of the conveyor up or move the left side of the conveyor down.
3. Adjust the four adjustment bolts that control the conveyor table height as determined from **Step 2**. Note—*For adjustment bolt locations see the adjustment bolt shown in **Figure 39**.*



Figure 39. Conveyor table adjustment bolts (1 of 4 shown).

4. Tighten the lock nuts on the adjustment bolts, connect the resaw to the power, and repeat the checking and adjusting **Steps** until the measurements on your cut piece are within 0.030".

Tracking Conveyors

“Tracking” the conveyor belts means balancing the way they ride on the end rollers. The conveyors are tracking correctly when they are centered between the roller brackets on each side of the conveyor. If the conveyor belts start rubbing against the roller brackets, then you need to track them as described.

To set the conveyor tracking:

1. Loosen the two roller bracket cap screws (shown in **Figure 40**) about $\frac{3}{4}$ of a turn. Do this on the both sides of the conveyor.

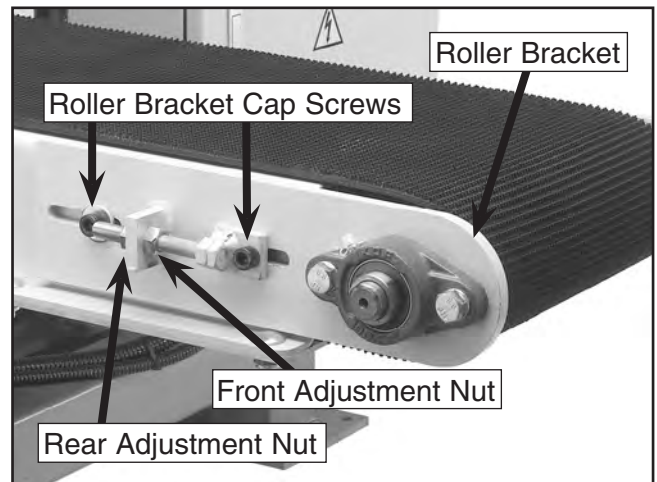

Figure 40. Roller bracket cap screws and adjustment nuts.

2. Loosen the rear adjustment nuts away from the bracket plates on both sides of the conveyor.
3. Start the conveyor belt.
4. On the side that the belt tracks toward, turn the front adjustment nut counter-clockwise half of a turn, and watch the belt tracking. Note—*The effect of the adjustment can sometimes take two minutes before the results are fully apparent.*

— If the tracking was not corrected by this adjustment, proceed to **Step 5**. If the tracking was corrected, skip to **Step 6**.



5. On the side that the belt tracks away from, turn the front adjustment nut clockwise half of a turn, and watch the belt tracking.

— If the tracking was not corrected by this adjustment, repeat **Step 4**.

6. When the conveyor belt is tracking in the center of the roller brackets, run the conveyor for at least two minutes to ensure that it will remain tracking correctly.
7. Tighten the rear adjustment nuts against the bracket plates, then tighten the front adjustment nuts against the bracket plates to make sure that the tracking adjustment will not slowly change during normal operation.



Replacing Conveyors

Although the conveyor belts have slight differences in size and access, the replacement instructions are the same.

To replace the conveyor belts:

1. Start the conveyor belt that you want to replace.
2. Stop the conveyor belt when the conveyor belt seam (see **Figure 41**) is accessible.

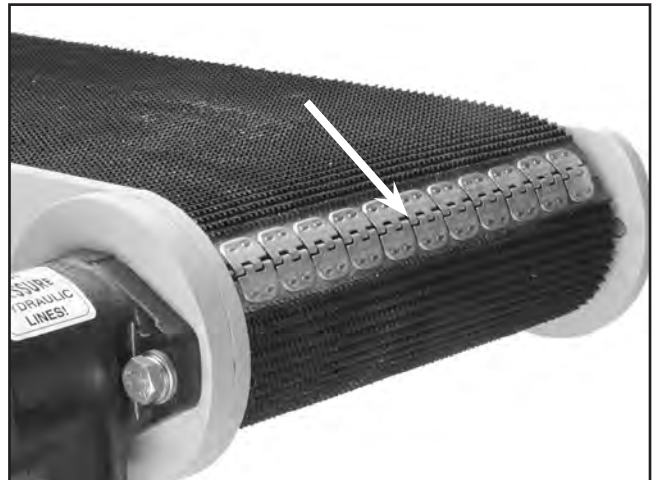

Figure 41. Conveyor belt seam.

3. **Disconnect the resaw from the power source!**
4. Loosen the roller bracket (see **Figure 42**) by turning the roller bracket cap screws $\frac{3}{4}$ of a turn.

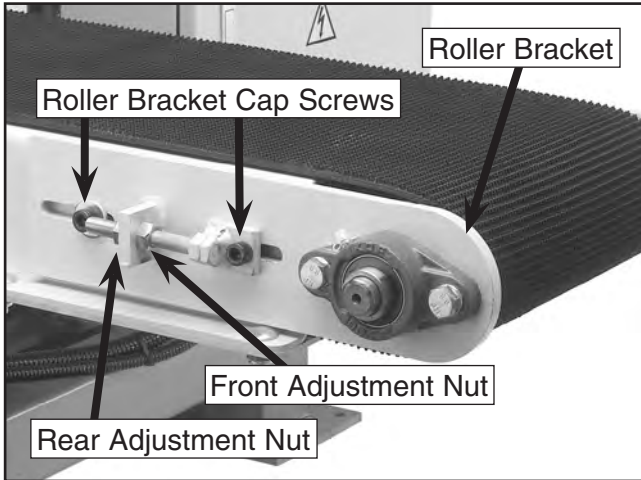

Figure 42. Roller bracket cap screws and adjustment nuts.

5. Loosen the rear adjustment nuts away from the bracket plate.
6. Mark the front adjustment nut with a felt-tipped pen or a piece of tape, and thread the front adjustment nut all the way up, while keeping track of the number of full turns that you moved the nut.

Note—Write the number of turns down, so you do not forget. Remembering this number is an important part of the re-assembly process.

7. Slide the roller brackets toward the body of the resaw to loosen the belt.
8. Remove the stiff cable from the center of the seam to separate it.
9. Remove the old conveyor belt from the conveyor table, and replace the new conveyor belt in its place.
10. Mesh the seam “teeth” together on the new belt, and insert the stiff cable into the center of the seam to lock it together.
11. Slide the roller brackets away from the body of the resaw to tighten the belt.
12. Turn the front adjustment bolts the exact number of rotations that you turned them when you loosened them.

Note—The new belt may be tighter than the old one because it has not been broken-in. If this is the case, deduct one or two turns from your original number of turns.

13. Run the conveyor belt to check the tracking. If the belt starts tracking to one side, stop the resaw and perform the “Tracking Conveyors” instructions that are located on **Pages 38**.



Blade Tracking and Wheel Alignment

Blade tracking on the Model G0504 consists of adjusting the wheels to be nearly coplanar (coplanar=both wheels even and parallel), but having the outside edge of the wheel approximately 0.020"-0.040" behind the inside edge of the wheel to compensate for wheel toe-in when the blade is fully tensioned.

Because of the large size of this machine and the wheel toe-in factor, this procedure is time consuming and requires a great deal of trial and error. Make sure you really need to perform this procedure before attempting it.

Also, to complete this procedure you will need to make four precision gauge blocks and have a 6' long straightedge.

To adjust the wheels to be coplanar:

1. **Disconnect the resaw from the power source!**
2. Open the wheel cover.
3. Remove the blade.
4. Using 2x4's, make four precision gauge blocks to the specifications shown in **Figure 43**.

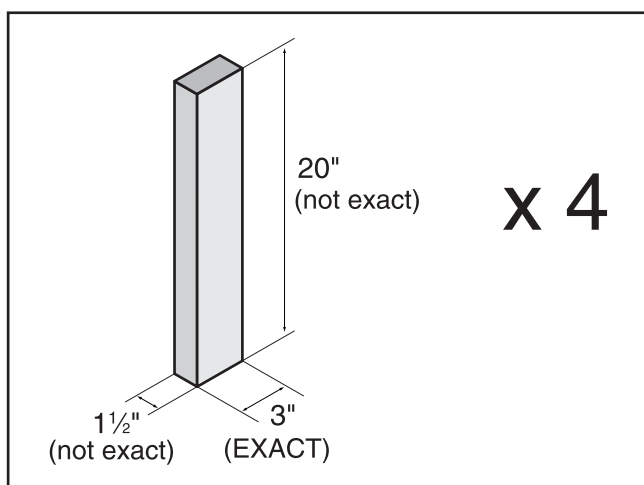

Figure 43. Precision gauge block dimensions.

5. Clamp the gauge blocks to the wheels as shown in **Figure 44**.

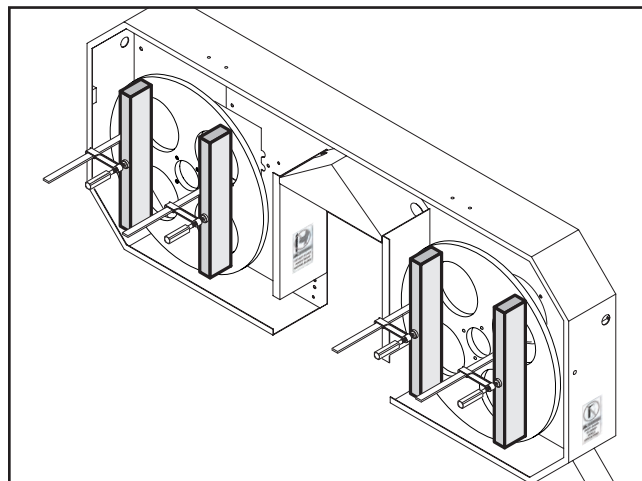

Figure 44. Precision gauge blocks clamped in position on wheels.

6. Place the straightedge across the top of the gauge blocks, as shown in **Figure 45**, and examine how the wheels line up with each other.

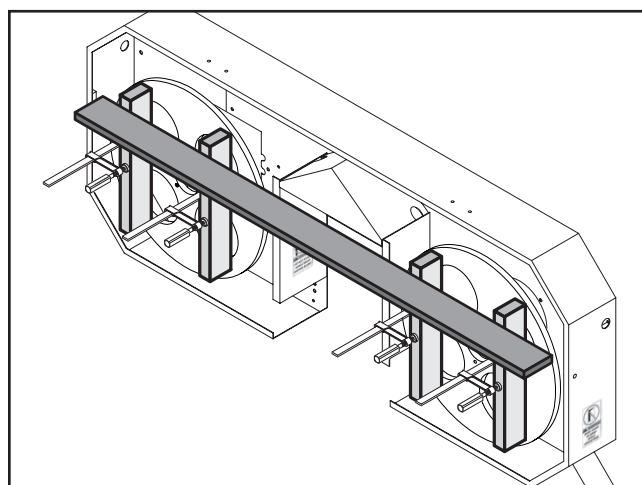

Figure 45. Straightedge placement when checking the upper portion of the wheels.

— If the wheels are properly aligned, the straightedge will touch both inside gauge blocks and there will be a 0.020"–0.040" gap between the straightedge and the outside gauge blocks, as shown in **Figure 46**. If this is the case, skip to **Step 9**.

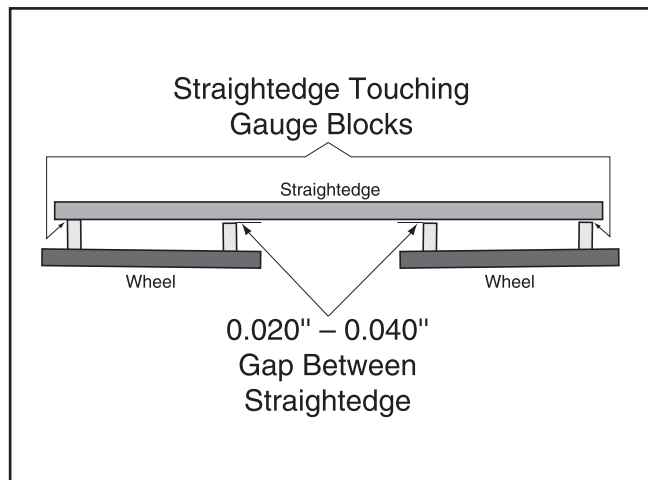

Figure 46. Overhead view of straightedge on blade wheel gauge blocks.

— If the wheels are not positioned as shown above, determine which direction they need to move in order to be correct, then proceed to **Step 7** to begin the adjustment process.

7. Look at the backside of the wheel guard and learn the controls shown in **Figures 47 & 48** by reading the text that follows.

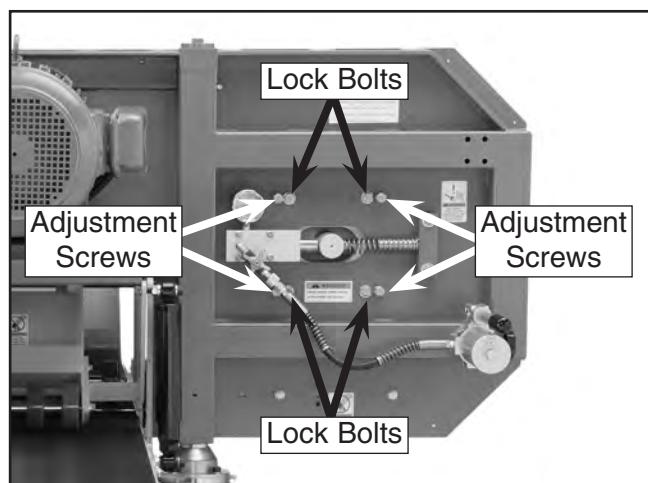

Figure 47. Tension wheel adjustment bolts.

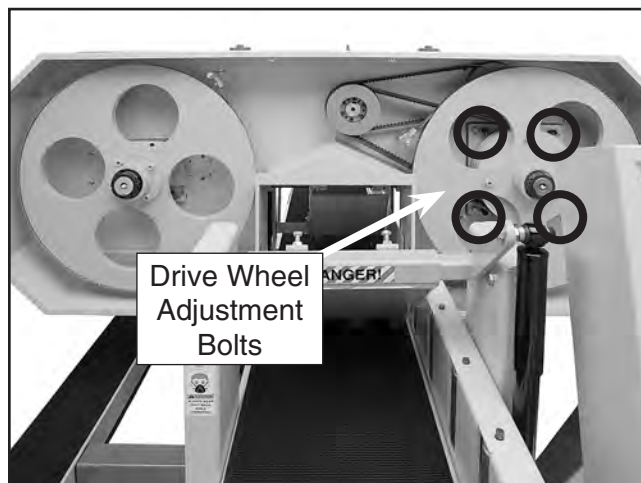

Figure 48. Drive wheel adjustment controls (fourth bolt hidden in this picture).

Movement Direction—The bolt position around the wheel shaft determines the part of the wheel that will move when that bolt is turned.

Moving Forward—To move part of the wheel forward, loosen the appropriate lock bolts the same amount that you will tighten their neighboring adjustment bolts. (By “appropriate” we mean the bolts that control the direction that your wheel needs to be moved.) In the case of the main drive wheel adjustments, always loosen the jam nuts before moving the adjustment bolts, and always tighten the jam nuts after moving the adjustment bolts.

Moving Backward—To move part of the wheel backward, loosen the appropriate adjustment bolt, then tighten the neighboring lock bolt.

8. Adjust the wheels as necessary until the wheel position is correct when checked with the straightedge and continue to **Step 9**.

9. Place the straightedge across the bottom of the gauge blocks, as shown in **Figure 49**. The wheels should line up in the same manner as described in **Step 6**.

— If they do not, follow **Steps 7–8** to correct them.

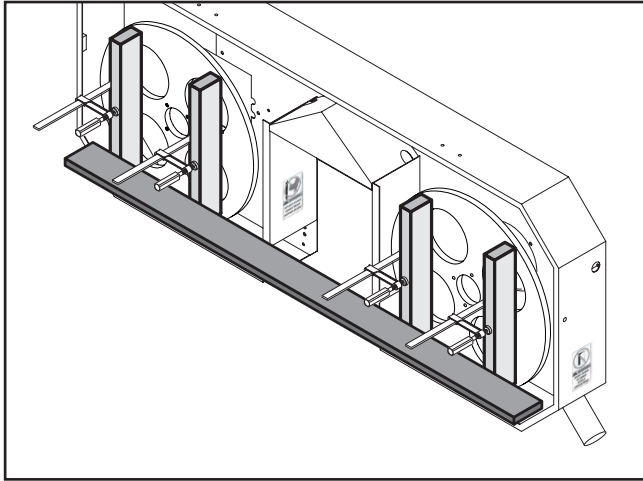

Figure 49. Straightedge placement when checking the lower portion of the wheels.

10. After the wheels are positioned correctly, install and tension the blade, and adjust the guide bearings out of the way of the blade.
11. Check the new position of the wheels. Ideally the gauge blocks will all be perfectly aligned with each other, as illustrated in **Figure 50**.

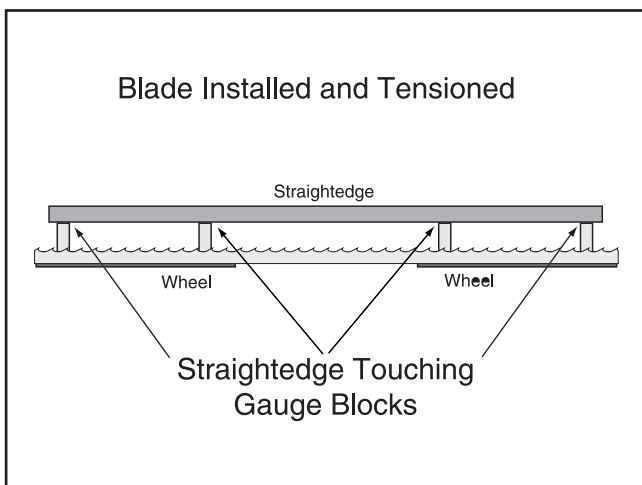

Figure 50. Overhead view of wheel position when checking with a straightedge and the blade is installed and tensioned.

— If the gauge blocks are aligned within 0.040" of each other, continue to **Step 12**.

— If the gauge blocks are positioned more than 0.040" from each other, repeat **Steps 6 & 9**, and make the new adjustments according to the change you noticed after tensioning the blade.

12. Remove the gauge blocks and clamps, and spin the wheels by hand in the direction of normal operation to check the blade tracking. You can fine tune the blade tracking by adjusting the blade tension up or down—just make sure to stay in the color range on the tension scale for your particular blade.
13. After the blade is tracking correctly, prepare the saw for a test run by adjusting the guide bearings, closing the wheel cover, and connecting the machine to the power source.
14. Test run the resaw and repeat this entire section if the blade does not track correctly.



Troubleshooting

Review the troubleshooting and procedures in this section to fix your machine if a problem develops. If you need replacement parts or you are unsure of your repair skills, then feel free to call our Technical Support at (570) 546-9663.

Symptom	Possible Cause	Possible Solution
Machine does not start or a breaker trips.	<ol style="list-style-type: none"> Emergency stop button is engaged. Electrical box door switch is OFF. Machine is wired to power source out of phase. Electrical box door is open/door safety switch is at fault. Motor connection wired incorrectly. Fuse has blown. Phase reversal relay is at fault. Computer board is at fault. Thermal overload relay has tripped. Contactor not getting energized/has burnt contacts. Blown/tripped wall fuse/circuit breaker. Power supply is at fault/switched OFF. Motor ON switch is at fault. Head elevation limit switch depressed; faulty. Wiring is open/has high resistance. Motor is at fault. 	<ol style="list-style-type: none"> Disengage emergency stop button. Turn electrical box door switch ON with the door closed. Switch any two current carrying wires at the power source connection. Close door/replace faulty safety switch. Correct motor wiring connections; check power source wire connections to ensure hot lines are "in phase" by reversing any two hot lines. Correct short/replace fuse. Replace phase reversal relay. Inspect computer board; replace if faulty. Turn cut-out dial to increase working amps and push the reset pin. Replace if tripped multiple times. Test for power on all legs and contactor operation. Replace unit if faulty. Replace weak breaker; ensure correct size circuit. Ensure hot lines have correct voltage on all legs and main power supply is switched ON. Replace switch. Adjust head height to correct working range; replace faulty limit switch. Check for broken wires or disconnected/corroded connections, and repair/replace as necessary. Test/repair/replace.
Machine stalls or is underpowered.	<ol style="list-style-type: none"> Wrong workpiece material (wood). Belt(s) slipping. Motor connection is wired incorrectly. Blade is slipping on wheels. Motor bearings are at fault. Machine is undersized for the task. Machine is undersized for the task. Motor has overheated. Contactor not getting energized or has poor contacts. Motor is at fault. Start delay module is at fault. 	<ol style="list-style-type: none"> Use wood with correct moisture content and low resins. Replace bad belt(s), align pulleys, and re-tension. Correct motor wiring connections. Adjust blade tracking and tension to factory specs. Test by rotating shaft; rotational grinding/loose shaft requires bearing replacement. Use sharp blade w/lower TPI; reduce the feed rate. Use sharp blade with lower TPI; reduce the feed rate/depth of cut; use cutting fluid if possible. Clean off motor, let cool, and reduce workload. Fix contacts or replace contactor. Test/repair/replace. Adjust to correct delay; replace module.

Symptom	Possible Cause	Possible Solution
Machine has excessive vibration or noisy operation.	<ol style="list-style-type: none"> 1. Motor or component is loose. 2. Blade weld at fault or teeth are broken. 3. V-belt(s) worn or loose. 4. Motor fan is rubbing on fan cover. 5. Pulley is loose. 6. Machine incorrectly mounted. 7. Motor bearings are at fault. 8. Blade is at fault. 	<ol style="list-style-type: none"> 1. Retighten/replace stripped or damaged bolts/nuts. 2. Replace blade. 3. Inspect/replace belts (refer to Page 37). 4. Replace dented fan cover; replace loose/damaged fan. 5. Realign/replace shaft, pulley, setscrew, or key. 6. Tighten/replace floor mounts; relocate/shim machine. 7. Replace bearings. 8. Replace warped, bent, or twisted blade; resharpen dull blade.
Machine slows when cutting.	<ol style="list-style-type: none"> 1. Feed rate is too fast. 2. Wood has a high moisture content. 3. V-belt does not have enough tension and is slipping on the pulleys. 4. V-belt is worn out. 	<ol style="list-style-type: none"> 1. Slow down the feed rate. 2. Only cut properly dried wood. 3. Tighten the V-belt (Page 36). 4. Replace V-belt (Page 37).
Blade does not run evenly on the wheels.	<ol style="list-style-type: none"> 1. Blade support bearings set incorrectly. 2. Wheels have built up pitch or dust. 3. Wheels are not coplanar. 4. Shape of wheels has changed from long term use and wear. 	<ol style="list-style-type: none"> 1. Adjust blade support bearings (Page 21). 2. Clean wheels of all pitch and dust. 3. Call the Grizzly Service Department at (570) 546-9663 for help determining if your wheels really are NOT coplanar; adjust wheels to be coplanar as described on Page 41. 4. Replace wheels.
Blade does not cut evenly.	<ol style="list-style-type: none"> 1. Blade is not properly tensioned. 2. Wheels are not coplanar. 3. Tooth set is uneven. 4. Teeth are sharper on one side than the other. 	<ol style="list-style-type: none"> 1. Adjust blade tension (Page 19). 2. Call the Grizzly Service Department at (570) 546-9663 for help determining if your wheels really are NOT coplanar; adjust wheels to be coplanar as described on Page 41. 3. Replace blade. 4. Replace blade.
Blade makes a squealing noise, especially on startup.	<ol style="list-style-type: none"> 1. V-belt is loose. 2. V-belt is worn out. 	<ol style="list-style-type: none"> 1. Tighten the V-belt (Page 36). 2. Replace V-belt (Page 37).
Ticking sound when the saw is running.	<ol style="list-style-type: none"> 1. Blade weld is contacting the guide blocks or support bearing. 	<ol style="list-style-type: none"> 1. Use the Model G2516 stone to smooth the blade weld.
Hydraulic pump is noisy or hydraulic system operates erratically.	<ol style="list-style-type: none"> 1. Pump is restricted. 2. Filter is clogged. 3. Tank screen is clogged. 4. Damaged hydraulic pump or motor. 	<ol style="list-style-type: none"> 1. Inspect and clean breather cap, filter, and tank screen. 2. Perform minor service (Page 32). 3. Perform major service (Page 33). 4. Replace pump or motor. See hydraulic specialist.

SECTION 9: Parts

Housing Parts

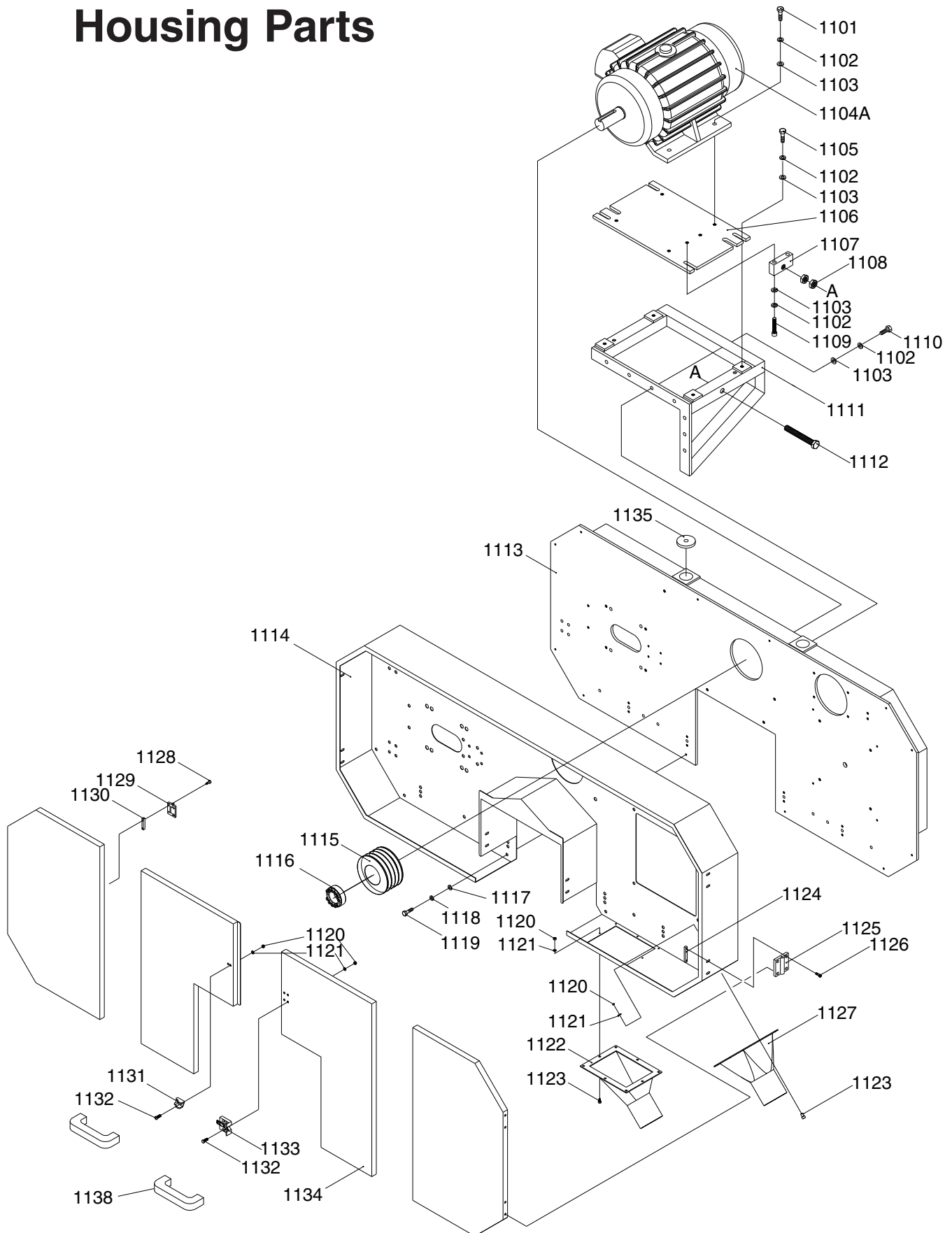

Housing Parts List

REF	PART #	DESCRIPTION
1101	PB27M	HEX BOLT M12-1.75 X 30
1102	PLW05M	LOCK WASHER 12MM
1103	PW06M	FLAT WASHER 12MM
1104A	P05041104A	MOTOR 30 HP
1105	PB24M	HEX BOLT M12-1.75 X 45
1107	P05041107	ADJUSTMENT BLOCK
1108	PN28M	HEX NUT M20-2.5
1109	PB125M	HEX BOLT M12-1.75 X 65
1110	PB25M	HEX BOLT M12-1.75 X 25
1113	P05041113	SAW WHEEL FRAME
1114	P05041114	SAW WHEEL GUARD
1115	P05041115	MOTOR PULLEY
1116	P05041116	LOCKING SLEEVE
1117	PW01M	FLAT WASHER 8MM
1118	PLW04M	LOCK WASHER 8MM
1119	PB87M	HEX BOLT M8-1.25 X 15
1120	PN01M	HEX NUT M6-1
1121	PLW03M	LOCK WASHER 6MM
1122	P05041122	DUST PORT B
1123	PB02M	HEX BOLT M6-1 X 12
1124	P05041124	BUTTON BRACKET
1125	P05041125	BUTTON DH-75
1126	PB08M	HEX BOLT M6-1 X 20
1127	P05041127	DUST PORT A
1128	PB95M	HEX BOLT M5-.8 X 16
1129	P05041129	BUTTON DK-50
1130	P05041130	BUTTON BRACKET
1131	P05041131	KNOB BRACKET
1132	PB08M	HEX BOLT M6-1 X 20
1133	P05041133	KNOB SEAT
1134	P05041134	DOOR PLATE
1135	P05041135	HEX BOLT M20-2.5 X 150
1136	P05041136	MOTOR BRACKET
1137	P05041137	MOTOR BRACKET
1138	P05041138	WHEEL COVER HANDLE

Frame Parts

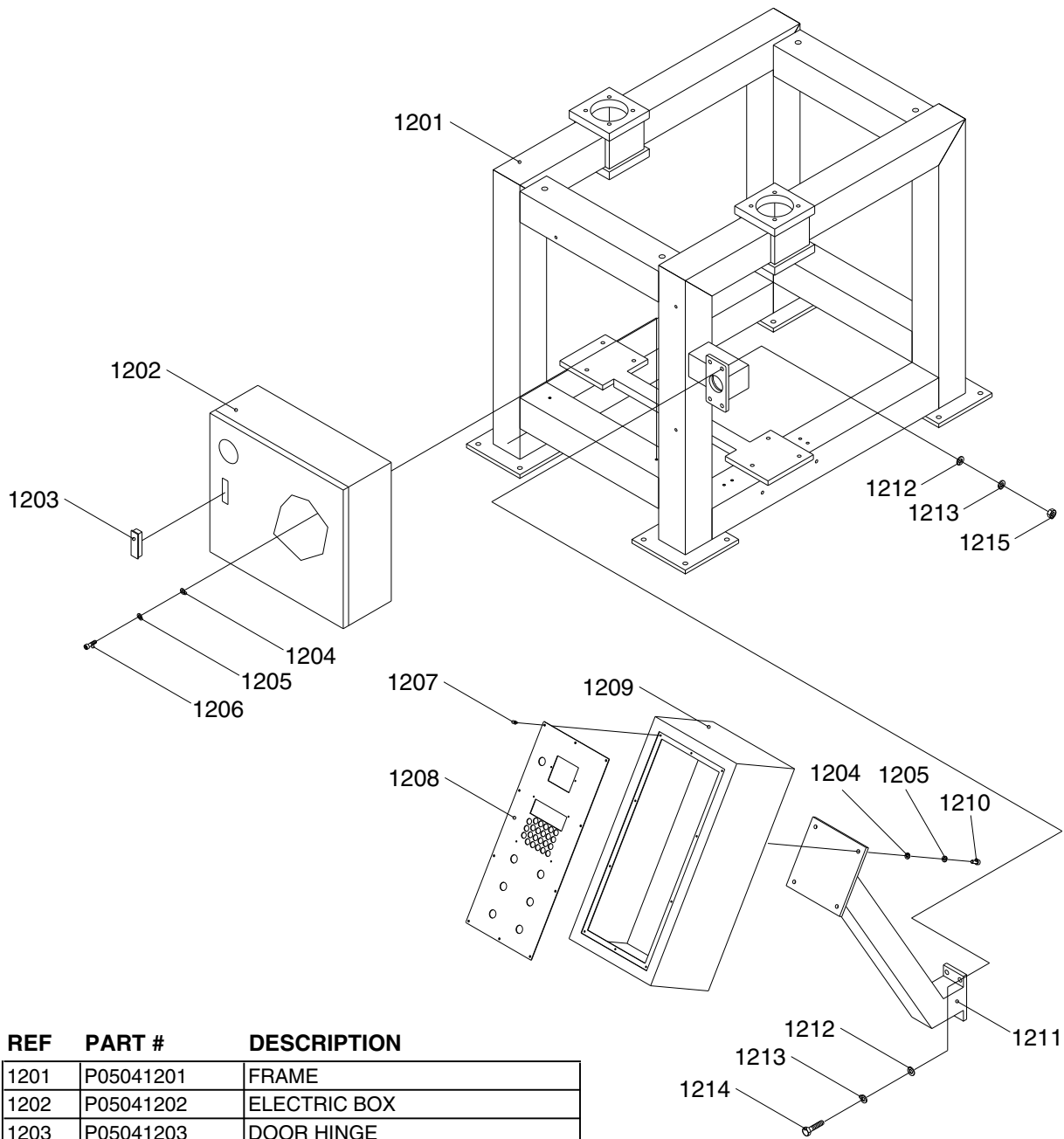

REF	PART #	DESCRIPTION
1201	P05041201	FRAME
1202	P05041202	ELECTRIC BOX
1203	P05041203	DOOR HINGE
1204	PW01M	FLAT WASHER 8MM
1205	PLW04M	LOCK WASHER 8MM
1206	PB09M	HEX BOLT M8-1.25 X 20
1207	PS07M	PHLP HD SCR M4-.7 X 8
1208	P05041208	CONTROL PANEL
1209	P05041209	CONTROL BOX
1210	PB07M	HEX BOLT M8-1.25 X 25
1211	P05041211	CONTROL BOX SUPPORT
1212	PW04M	FLAT WASHER 10MM
1213	PLW06M	LOCK WASHER 10MM
1214	PB31M	HEX BOLT M10-1.5 X 40
1215	PN02M	HEX NUT M10-1.5

Elevation Parts

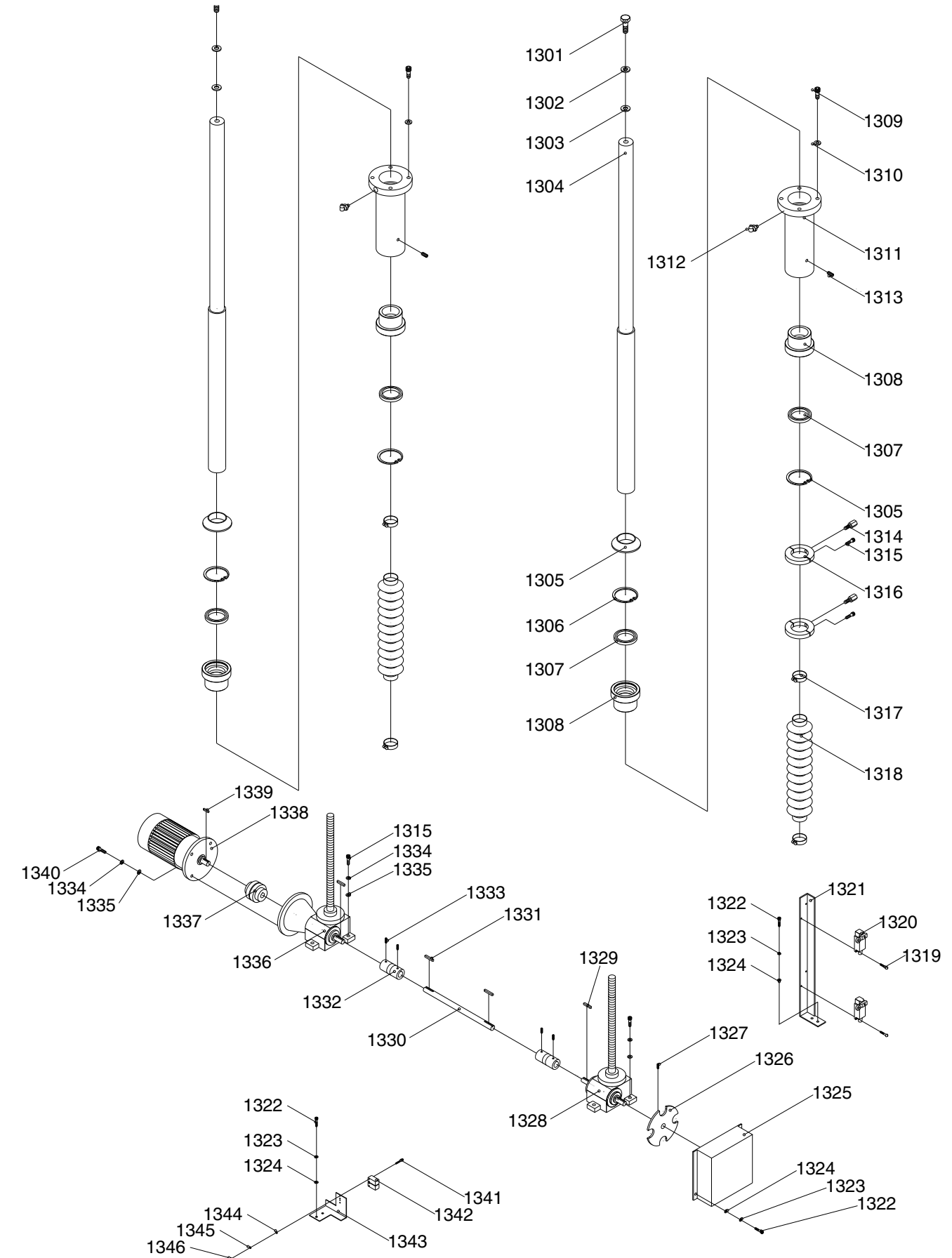

Elevation Parts List

REF	PART #	DESCRIPTION
1301	PB110M	HEX BOLT M16-2 X 25
1302	PLW10M	LOCK WASHER 16MM
1303	PW08M	FLAT WASHER 16MM
1304	P0504204	COLUMN
1305	P0504205	CHIP COVER
1306	PR50M	INT RETAINING RING 80MM
1307	P0504207	OIL SEAL 60 X 80 X 10
1308	P0504208	BRASS SLEEVE
1309	PSB73M	CAP SCREW M12-1.75 X 50
1310	PLW05M	LOCK WASHER 12MM
1311	P0504211	ELEVATION HOUSING
1312	PZERK2	GREASE FITTING PT 1/8
1313	PSS30M	SET SCREW M10-1.5 X 10
1314	P0504214	LIMIT DOG
1315	PB15M	HEX BOLT M8-1.25 X 40
1316	P0504213	LOCK RING
1317	P0504216	TIGHTEN RING
1318	P0504217	DUST GUARD BELLOW
1319	PS65M	PHLP HD SCR M4-.7 X 40
1320	P0504219	LIMIT SWITCH AV8104
1321	P0504220	SWITCH BRACKET
1322	PSB02M	CAP SCREW M6-1 X 20
1323	PLW03M	LOCK WASHER 6MM
1324	PW03M	FLAT WASHER 6MM
1325	P0504224	COVER
1326	P0504225	INDEX RING
1327	PSS01M	SET SCREW M6-1 X 10
1328	P0504245	GEAR BOX 40# 1/30 VTW
1329	PK74M	KEY 6 X 6 X 35
1330	P0504244	CONNECT ROD
1331	PK11M	KEY 6 X 6 X 40
1332	P0504243	UNIVERSAL JOINT
1333	PSS64M	SET SCREW M6-1 X 15
1334	PLW04M	LOCK WASHER 8MM
1335	PW01M	FLAT WASHER 8MM
1336	P0504242	GEAR BOX A 40# 1/30 VTWM
1337	P0504241	SHAFT COUPLINGS
1338	P0504235	GEAR BOX & MOTOR
1339	PK12M	KEY 5 X 5 X 30
1340	PSB14M	CAP SCREW M8-1.25 X 20
1341	PSB99M	CAP SCREW M3-.5 X 30
1342	P0504250	SENSOR QL-1805NB
1343	P0504251	SENSOR BRACKET
1344	PW07M	FLAT WASHER 3MM
1345	PLW09M	LOCK WASHER 3MM
1346	PN07M	HEX NUT M3-.5

Blade Guide Parts

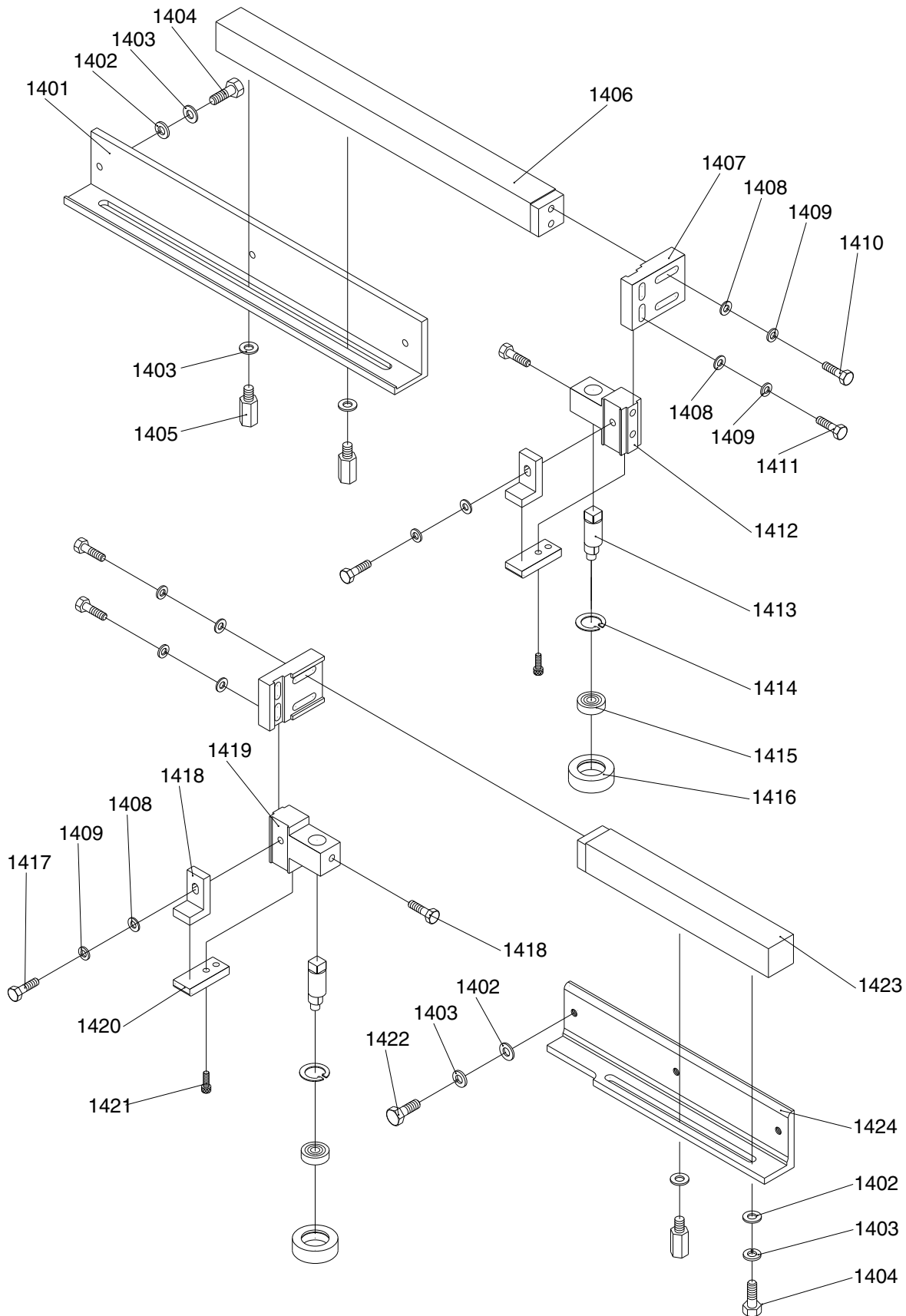

Blade Guide Parts

REF	PART #	DESCRIPTION
1401	P0504309	ADJUSTMENT ROD BRACKET
1402	PW04M	FLAT WASHER 10MM
1403	PLW06M	LOCK WASHER 10MM
1404	PB74M	HEX BOLT M10-1.5 X 20
1405	P0504310	ADJUSTMENT SCREW
1406	P0504305	GUIDE POST
1407	P0504304	ADJUSTMENT BRACKET
1408	PW01M	FLAT WASHER 8MM
1409	PLW04M	LOCK WASHER 8MM
1410	PB15M	HEX BOLT M8-1.25 X 40
1411	PB26M	HEX BOLT M8-1.25 X 30
1412	P0504314	GUIDE POST BASE
1413	P0503404	ECCENTRIC SHAFT
1414	PR35M	INT RETAINING RING 30MM
1415	P6200LLB	BALL BEARING 6200LLB
1416	P0504318	SUPPORT ROLLER
1417	PB09M	HEX BOLT M8-1.25 X 20
1418	P0504355	UPPER GUIDE (CERAMIC)
1419	P0504321	GUIDE POST BASE (R)
1420	P0504336	LOWER GUIDE (CERAMIC)
1421	PSB02M	CAP SCREW M6-1 X 20
1422	PB40M	HEX BOLT M10-1.5 X 15
1423	P0504319	GUIDE POST
1424	P0504320	POST BRACKET

Tensioning Wheel Parts

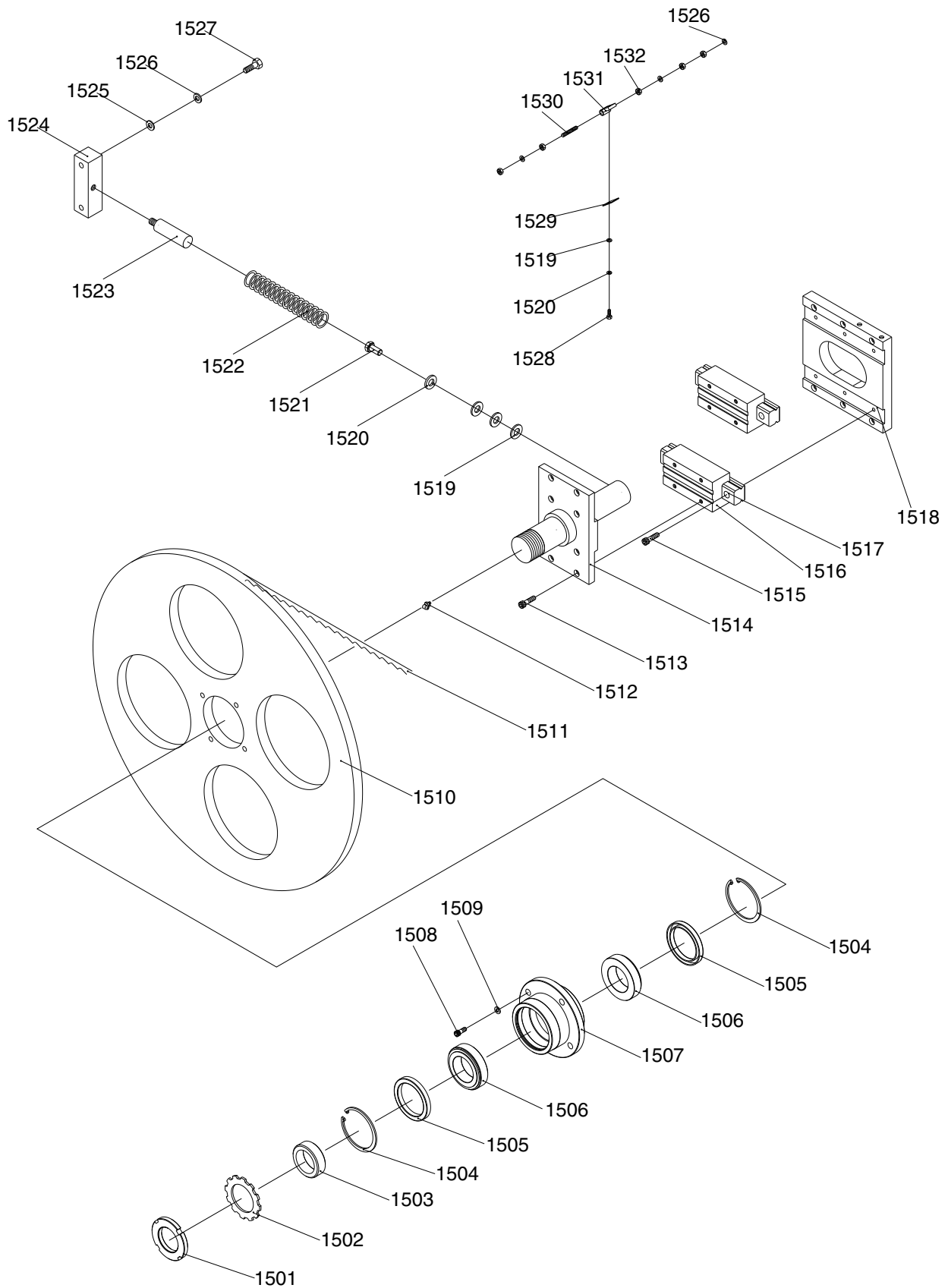

Tensioning Wheel Parts List

REF	PART #	DESCRIPTION
1501	P0504428A	LOCK NUT AN11
1502	PTLW08M	EXT TOOTH WASHER 10MM
1503	P0504429A	LOCK RING
1504	P0504455	INT RETAINING RING 90MM
1505	P0504456	OIL SEAL TC-70 X 90 X 8
1506	P32011	BEARING 32011
1507	P0504461	LEFT BEARING HOUSING
1508	PB35M	HEX BOLT M12-1.75 X 40
1509	PLW05M	LOCK WASHER 12MM
1510	P0504433	LEFT BLADE WHEEL
1511	P0504434	SAW BLADE 1" X 180"
1512	PZERK2	GREASE FITTING PT 1/8
1513	PSB100M	CAP SCREW M8-1.25 X 15
1514	P050442A	LEFT WHEEL SHAFT
1515	PSB13M	CAP SCREW M8-1.25 X 30
1516	P0504437	SLIDER
1517	P0504437	LINER GUIDE
1518	P0504438	LINER WAY BRACKET
1519	PW01M	FLAT WASHER 8MM
1520	PLW04M	LOCK WASHER 8MM
1521	PB26M	HEX BOLT M8-1.25 X 30
1522	P0504443	SPRING
1523	P0504444	SPRING ROD
1524	P0504445	SPRING SEAT
1525	PW04M	FLAT WASHER 10MM
1526	PLW06M	LOCK WASHER 10MM
1527	PB73M	HEX BOLT M10-1.5 X 50
1528	PSB52M	CAP SCREW M8-1.25 X 10
1529	P0504415	WHEEL SCRAPE
1530	PS66M	PHLP HD SCR M10-1.5 X 150
1531	P0504417	CLEANER BASE
1532	PN02M	HEX NUT M10-1.5

Drive Wheel Parts

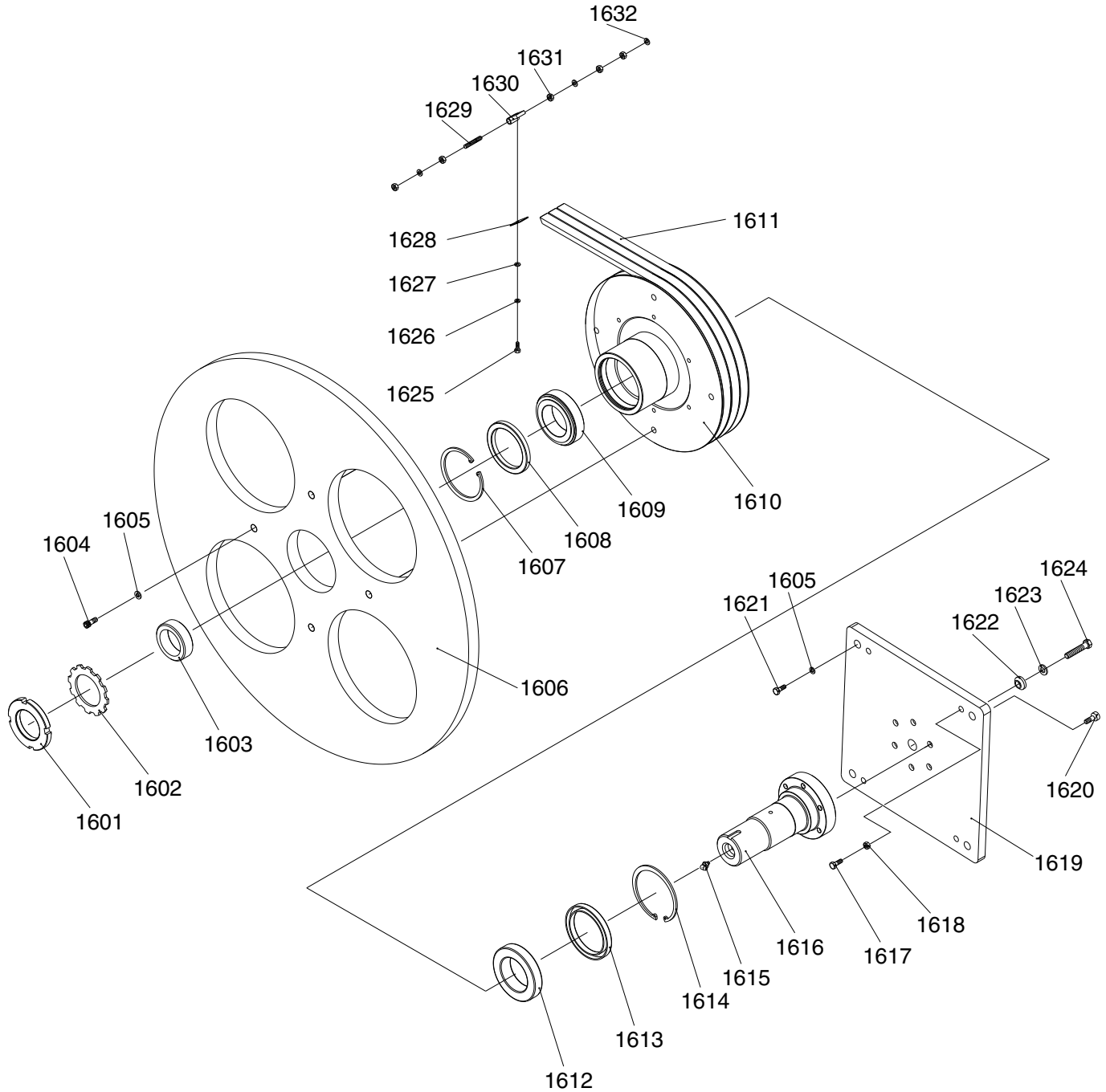

REF	PART #	DESCRIPTION
1601	P0504428A	LOCK NUT AN11
1602	PTLW08M	EXT TOOTH WASHER 10MM
1603	P0504429A	LOCK RING
1604	PSB73M	CAP SCREW M12-1.75 X 50
1605	PLW05M	LOCK WASHER 12MM
1606	P0504403	RIGHT BLADE WHEEL
1607	P0504455	INT RETAINING RING 90MM
1608	P0504456	OIL SEAL TC-70 X 90 X 8
1609	P32011	BEARING 32011
1610	P05041610	BEARING SEAT-LEFT

REF	PART #	DESCRIPTION
1611	P05041611	BELT 5V X 740
1612	P32012	TAPER ROLLER BEARING 32012
1613	P05041613	OIL SEAL TC-75 X 95 X 10
1614	P05041614	INT RETAINING RING 95MM
1615	PZERK2	GREASE FITTING PT 1/8
1616	P05041616	RIGHT WHEEL SHAFT
1617	PB25M	HEX BOLT M12-1.75 X 25
1618	PN09M	HEX NUT M12-1.75
1619	P05041619	WHEEL ADJUSTMENT PLATE

Hydraulic Pump Parts

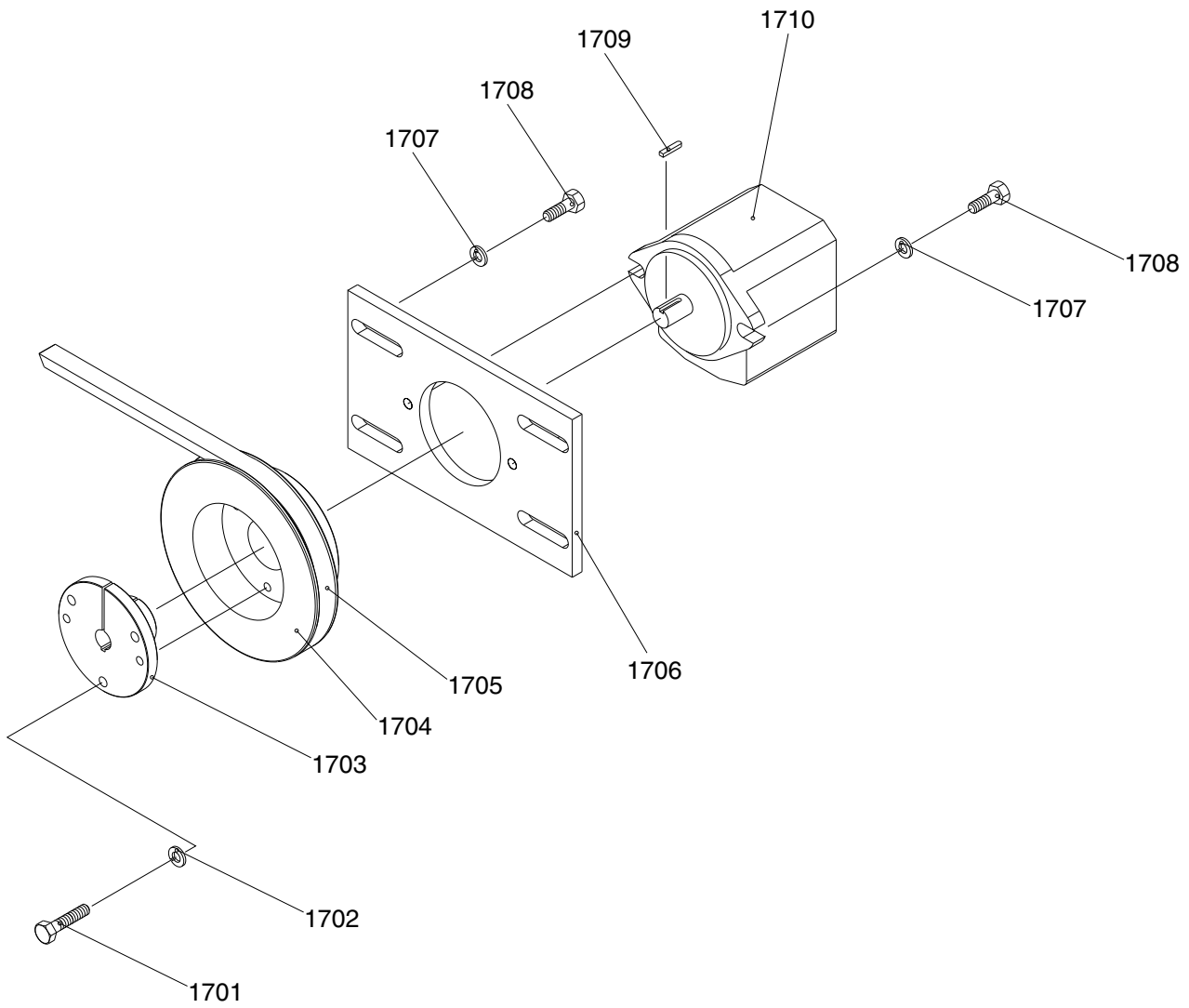

REF	PART #	DESCRIPTION
1701	PB09M	HEX BOLT M8-1.25 X 20
1702	PLW04M	LOCK WASHER 8MM
1703	P05041703	PULLEY SLEEVE
1704	P05041704	PULLEY
1705	P05041705	V-BELT B X 53

REF	PART #	DESCRIPTION
1706	P05041706	MOTOR BRACKET
1707	PLW06M	LOCK WASHER 10MM
1708	PB74M	HEX BOLT M10-1.5 X 20
1709	PK47M	KEY 4 X 4 X 15
1710	P05041710	HYDRAULIC PUMP

Main Conveyor Table Parts

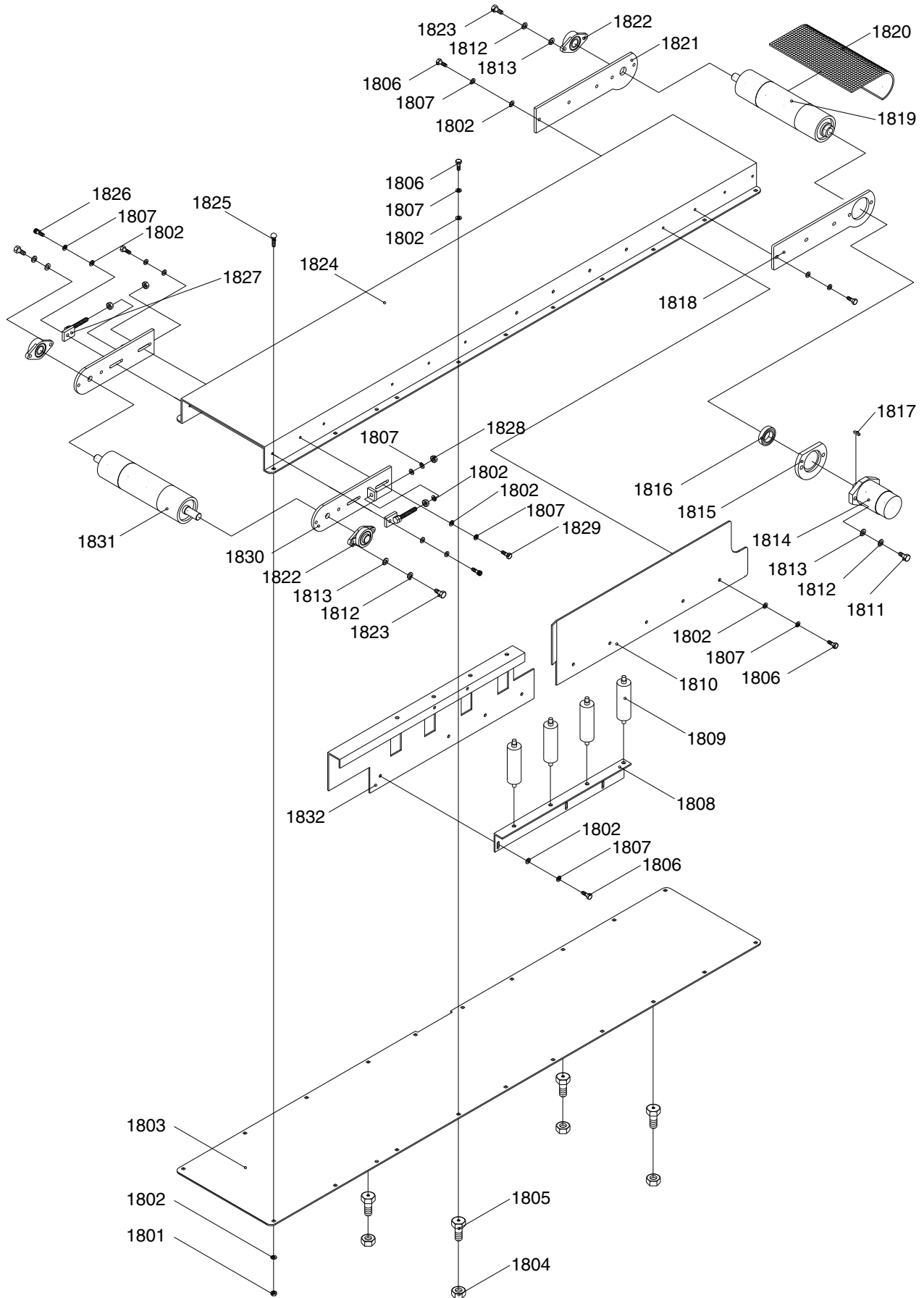

Main Conveyor Table Parts List

REF	PART #	DESCRIPTION
1801	PLN05M	LOCK NUT M10-1.5
1802	PW04M	FLAT WASHER 10MM
1803	P0504603	CONVEYOR LOWER PLATE
1804	PN33M	HEX NUT M24-2
1805	P0504605	ADJUSTMENT BOLT
1806	PB01M	HEX BOLT M10-1.5 X 30
1807	PLW06M	LOCK WASHER 10MM
1808	P0504609	ROLLER SEAT
1809	P0504610	ROLLER
1810	P0504611B	ROLLER PLATE (REAR)
1811	PB33M	HEX BOLT M12-1.75 X 50
1812	PLW05M	LOCK WASHER 12MM
1813	PW06M	FLAT WASHER 12MM
1814	P05041814	HYDRAULIC MOTOR OMP250
1815	P0504618A	MOTOR BEARING SEAT
1816	P6008LLB	BALL BEARING 6008LLB
1817	PK13	KEY 1/4 X 1/4 X 1-1/2
1818	P0504621	REAR ROLLER BRACKET R
1819	P0504622	REAR ROLLER
1820	P0504623	CONVEYOR BELT 400
1821	P0504624	REAR ROLLER BRACKET L
1822	P0504625	FLANGE BEARING UCFL205
1823	PB25M	HEX BOLT M12-1.75 X 25
1824	P0504636	CONVEYOR PLATEN
1825	PCB09M	CARRIAGE BOLT M10-1.5 X 25
1826	PB01M	HEX BOLT M10-1.5 X 30
1827	P0504637	ADJUSTMENT SCREW
1828	PN02M	HEX NUT M10-1.5
1829	PB32M	HEX BOLT M10-1.5 X 25
1830	P0504649	FRONT ROLLER SUPPORT
1831	P0504650	FRONT ROLLER
1832	P0504611A	ROLLER PLATE (FRONT)

Return Conveyor Table Parts

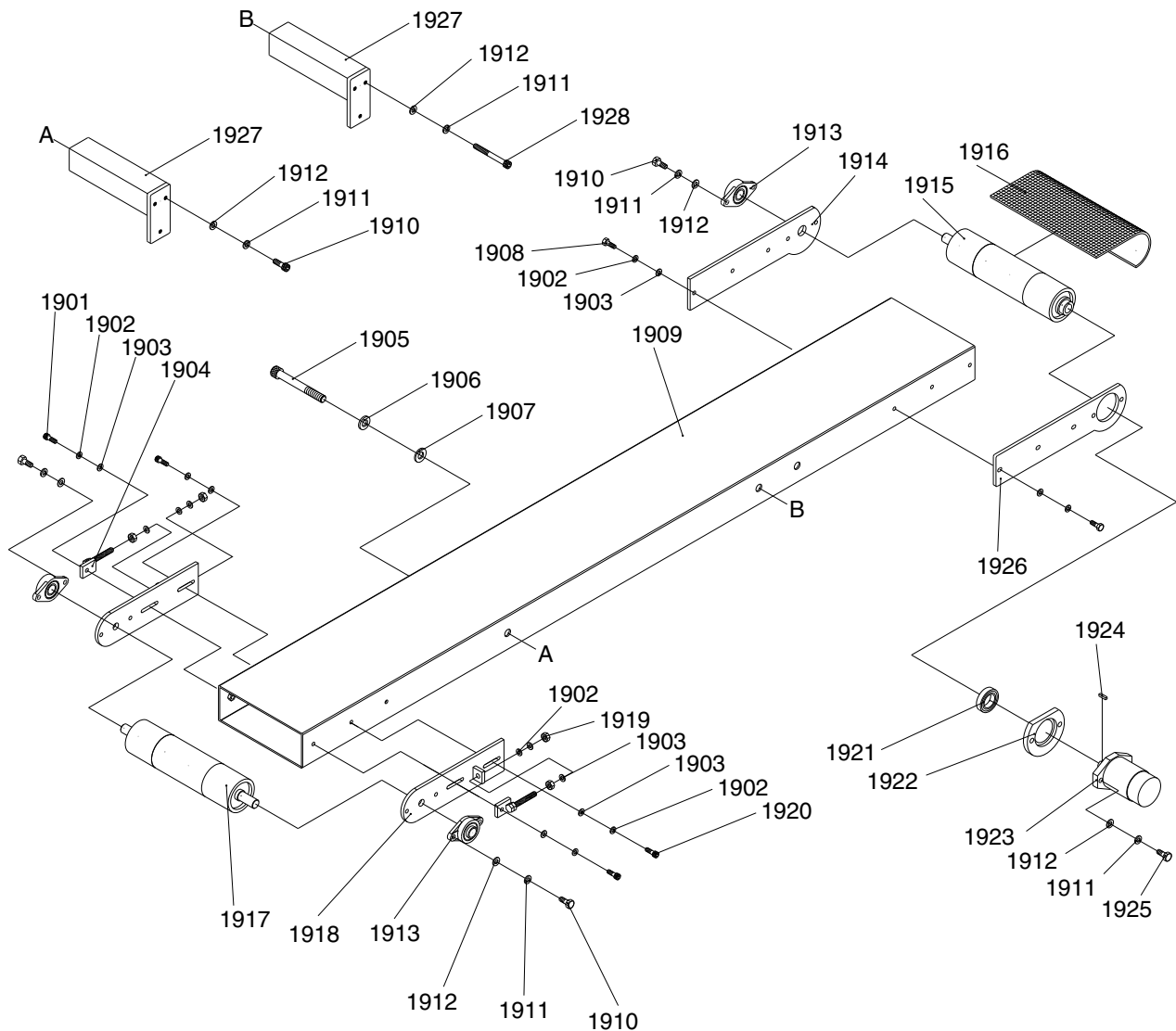

REF	PART #	DESCRIPTION
1901	PSB72M	CAP SCREW M10-1.5 X 30
1902	PLW06M	LOCK WASHER 10MM
1903	PW04M	FLAT WASHER 10MM
1904	P0504827	ADJUSTMENT BOLT
1905	P05041905	HEX BOLT M20-2.5 X 230
1906	PLW06M	LOCK WASHER 10MM
1907	PW04M	FLAT WASHER 10MM
1908	PB01M	HEX BOLT M10-1.5 X 30
1909	P05041909	CONVEYOR SEAT
1910	PB25M	HEX BOLT M12-1.75 X 25
1911	PLW05M	LOCK WASHER 12MM
1912	PW06M	FLAT WASHER 12MM
1913	P0504625	FLANGE BEARING UCFL205
1914	P0504624	REAR ROLLER BRACKET L

REF	PART #	DESCRIPTION
1915	P05041915	REAR ROLLER
1916	P05041916	CONVEYOR BELT 185 X 5480
1917	P05041917	FRONT ROLLER
1918	P0504649	FRONT ROLLER BRACKET
1919	PN02M	HEX NUT M10-1.5
1920	PB32M	HEX BOLT M10-1.5 X 25
1921	P6008LLB	BALL BEARING 6008LLB
1922	P05041922	OIL PUMP FLANGE
1923	P05041923	HYDRAULIC MOTOR OMP160
1924	PK42M	KEY 6 X 6 X 30
1925	PB33M	HEX BOLT M12-1.75 X 50
1926	P0504621A	REAR ROLLER BRACKET R
1927	P05041927	CONVEYOR SUPPORT
1928	PB143M	HEX BOLT M12-1.75 X 120

Rear Hold Down Parts

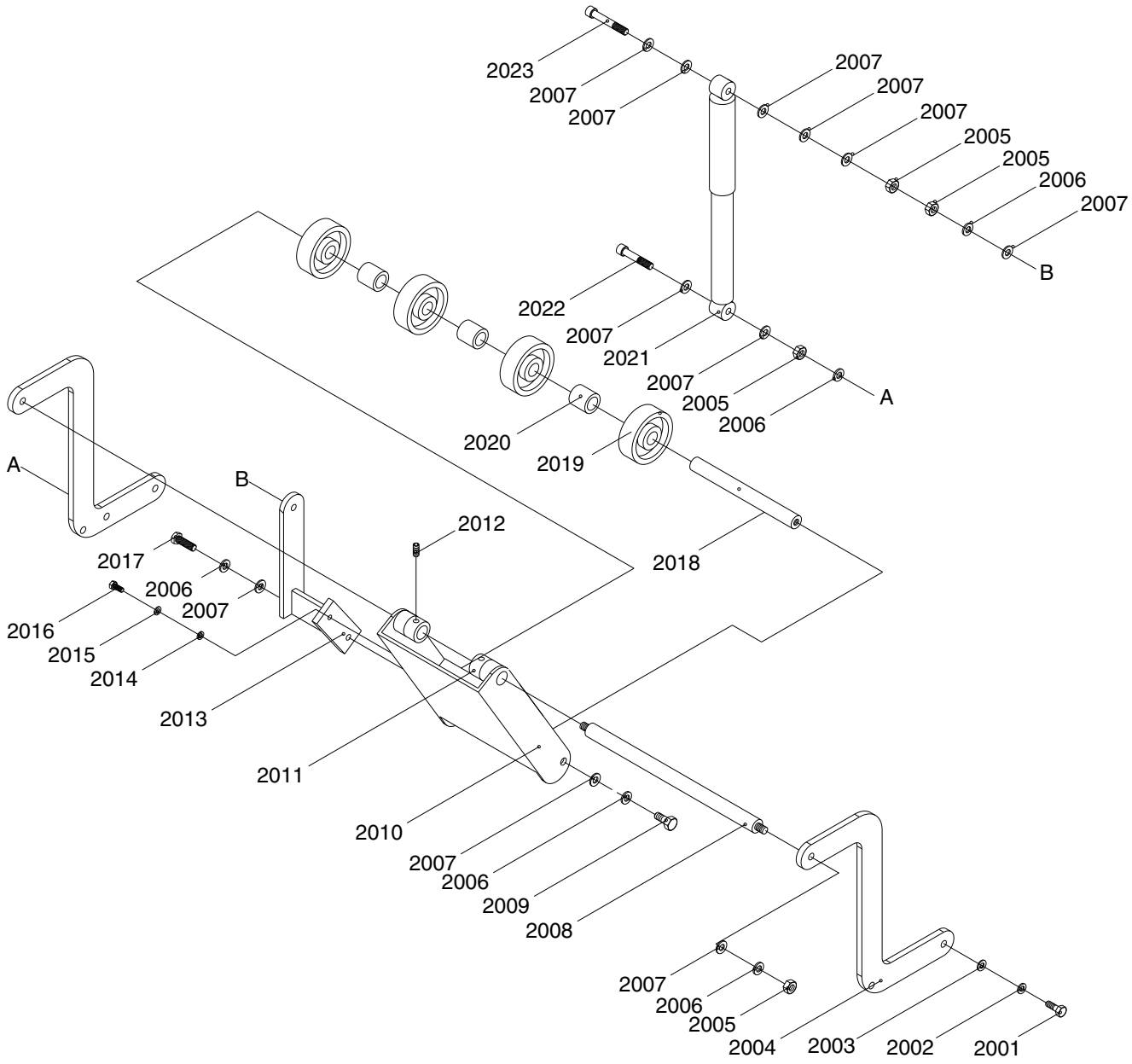

REF	PART #	DESCRIPTION
2001	PB01M	HEX BOLT M10-1.5 X 30
2002	PLW06M	LOCK WASHER 10MM
2003	PW04M	FLAT WASHER 10MM
2004	P0504753	REAR ROLLER SUPPORT
2005	PN09M	HEX NUT M12-1.75
2006	PLW05M	LOCK WASHER 12MM
2007	PW06M	FLAT WASHER 12MM
2008	P05042008	REAR ROLLER SHAFT
2009	PSB129M	CAP SCREW M12-1.75 X 20
2010	P0504757	REAR PRESSURE PLATE
2011	P0504758	COLLAR
2012	PSS30M	SET SCREW M10-1.5 X 10

REF	PART #	DESCRIPTION
2013	P05042013	FIXED SEAT
2014	PSB14M	CAP SCREW M8-1.25 X 20
2015	PLW04M	LOCK WASHER 8MM
2016	PW01M	FLAT WASHER 8MM
2017	PSB77M	CAP SCREW M12-1.75 X 30
2018	P05042018	REAR ROLLER SHAFT
2019	P0504747	PRESSURE ROLLER WHEEL
2020	P0504763	COLLAR
2021	P05042021	SHOCK ABSORBER
2022	PB125M	HEX BOLT M12-1.75 X 65
2023	PB141M	HEX BOLT M12-1.75 X 80

Front Hold Down Parts

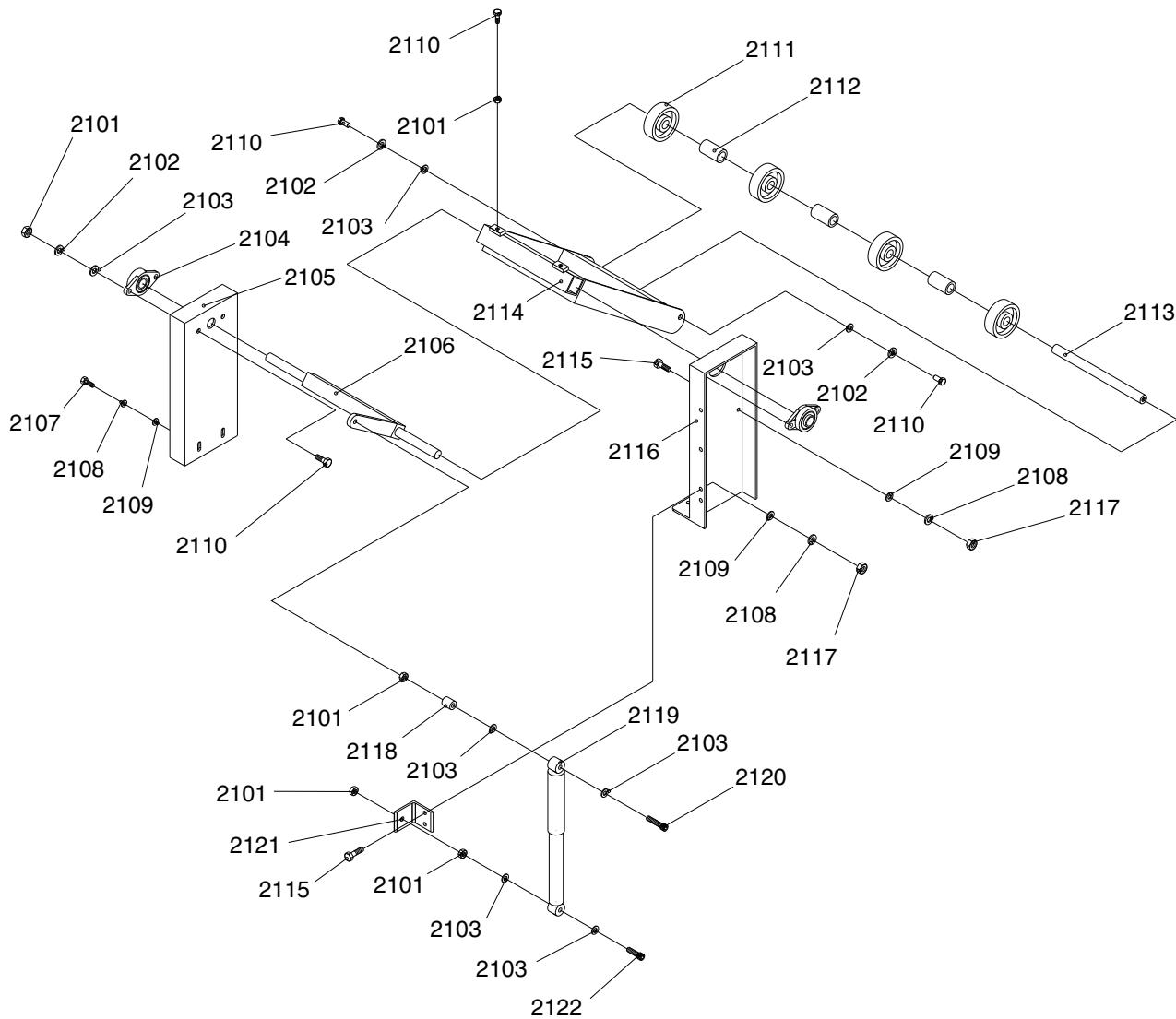

REF	PART #	DESCRIPTION
2101	PN09M	HEX NUT M12-1.75
2102	PLW05M	LOCK WASHER 12MM
2103	PW06M	FLAT WASHER 12MM
2104	P0504625	FLANGE BEARING UCFL205
2105	P0504721	PRESSURE ROLLER SUPPORT (L)
2106	P0504727	UPPER SHAFT
2107	PB32M	HEX BOLT M10-1.5 X 25
2108	PLW06M	LOCK WASHER 10MM
2109	PW04M	FLAT WASHER 10MM
2110	PB49M	HEX BOLT M12-1.75 X 20
2111	P0504747	PRESSURE ROLLER WHEEL

REF	PART #	DESCRIPTION
2112	P0504748	COLLAR
2113	P0504749	FRONT ROLLER SHAFT
2114	P0504742	FRONT PRESSURE PLATE
2115	PB01M	HEX BOLT M10-1.5 X 30
2116	P0504731	PRESSURE ROLLER SUPPORT (R)
2117	PN02M	HEX NUT M10-1.5
2118	P0504716	COLLAR
2119	P0504709	SHOCK ABSORBER
2120	PSB101M	CAP SCREW M12-1.75 X 90
2121	P0504713	IRON PLATE
2122	PSB63M	CAP SCREW M12-1.75 X 60

Hydraulic System Parts

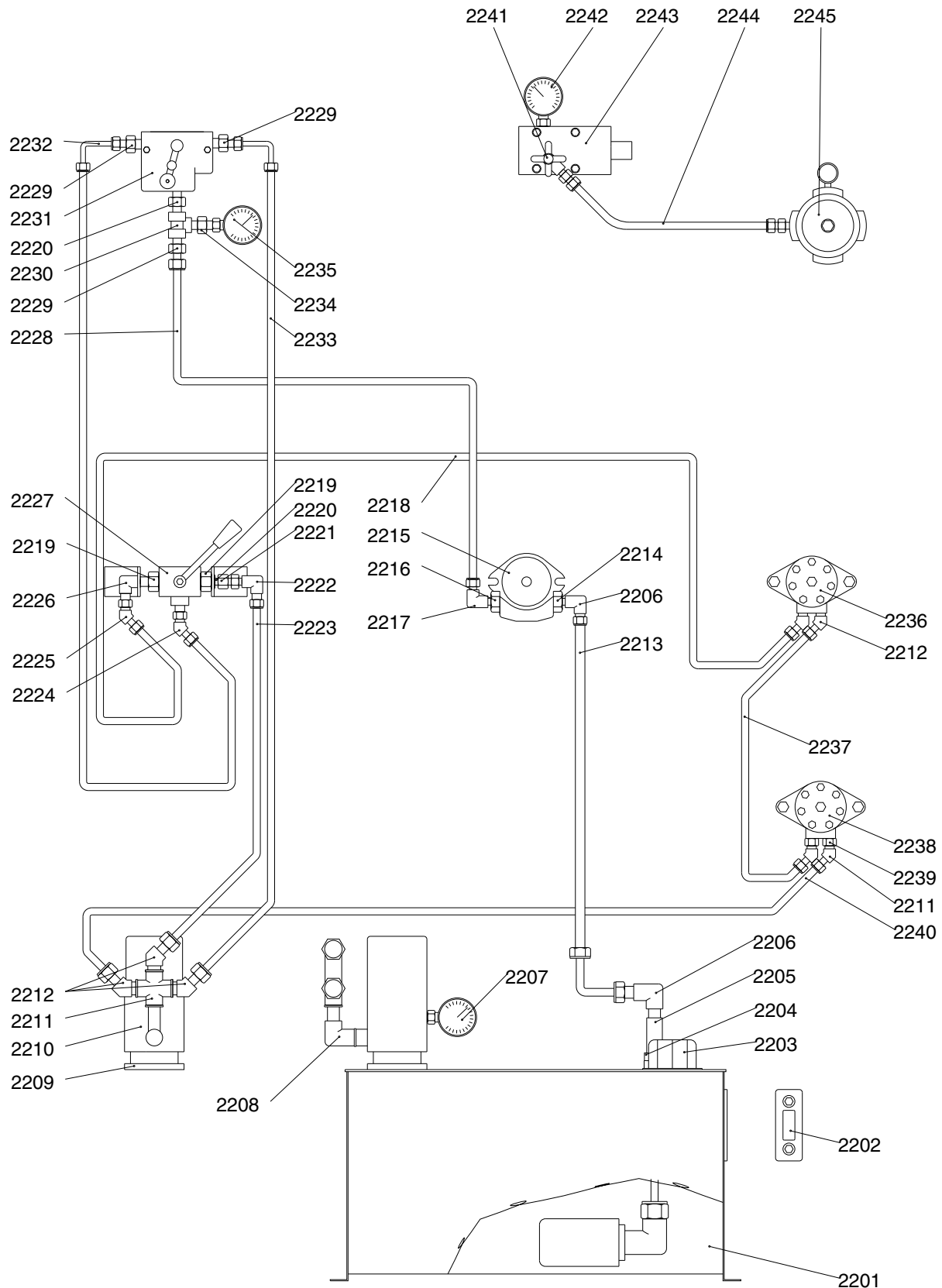

Hydraulic System Parts List

REF	PART #	DESCRIPTION
2201	P05042201	FUEL TANK
2202	P05042202	MANOMETER
2203	P05042203	OIL FILLER
2204	P05042204	CONNECTOR 3/4T X 3/4T
2205	P05042205	REVERSE VALVE 3/4"
2206	P05042206	CONNECTOR 3/4T X 3/4H X 45°
2207	P05042207	HYDRAULIC GAUGE
2208	P05042208	CONNECTOR 3/4T X 1/2T X 90° X
2209	P05042209	FILTER BRACKET
2210	P05042210	FILTER
2211	P05042211	CONNECTOR 1/2T
2212	P05042212	CONNECTOR 1/2T X 3/8H X 45°
2213	P05042213	OIL PIPE 3/4" X 63"
2214	P05042204	CONNECTOR 3/4T X 3/4T
2215	P05041710	HYDRAULIC PUMP
2216	P05042216	CONNECTOR 1/2T X 5/8T
2217	P05042217	CONNECTOR 1/2T X 3/8H
2218	P05042218	OIL PIPE 3/8" X 122"
2219	P05042219	CONNECTOR 3/8T X 3/8T
2220	P05042220	HEX OIL PUMPER 3/8T X 3/8T
2221	P05042221	CONNECTOR 3/8T X 3/8H
2222	P05042222	CONNECTOR 3/8H X 3/8H
2223	P05042223	OIL PIPE 3/8" X 75"
2224	P05042224	CONNECTOR 3/8T X 3/8H X 45°
2225	P05042225	CONNECTOR 3/8H X 3/8H X 45°
2226	P05042221	CONNECTOR 3/8T X 3/8H
2227	P05042227	BALL VALVE 3/8"
2228	P05042228	OIL PIPE 3/8" X 78-3/4"
2229	P05042229	HEX OIL PUMPER 3/8T X 3/8H
2230	P05042230	CONNECTOR 3/8T
2231	P05042231	CONTROL VALVE FC51-3/8
2232	P05042232	OIL PIPE 3/8" X 82-5/8"(90)
2233	P05042233	OIL PIPE 1/4" X 39-1/2"(90)
2234	P05042234	CONNECTOR 3/8T X 1/4T
2235	P05042235	HYDRAULIC GAUGE
2236	P05041814	HYDRAULIC MOTOR OMP250
2237	P05042237	OIL PIPE 3/8" X 94-1/2"
2238	P05041923	HYDRAULIC MOTOR OMP160
2239	P05042239	CONNECTOR 7/8-14UNF X 3/8T
2240	P05042240	OIL PIPE 3/8" X 39-1/2"
2241	P05042241	STOP VALVE
2242	P05042242	HYDRAULIC GAUGE
2243	P05042243	OIL PARTITION
2244	P05042244	OIL PIPE 1/4" X 240
2245	P05042245	PUMP

Electrical System Parts 1

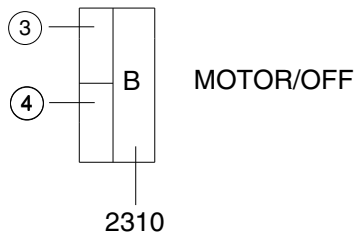
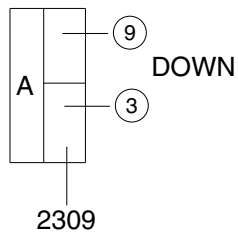
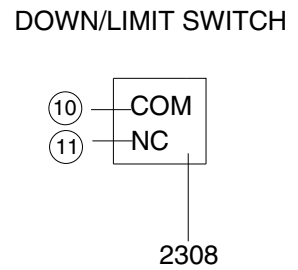
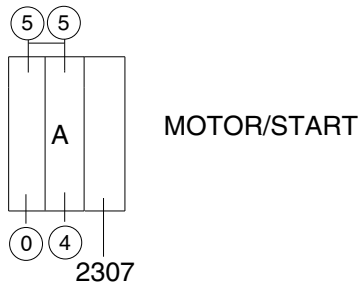
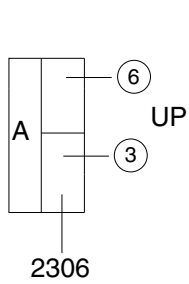
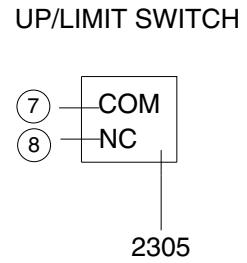
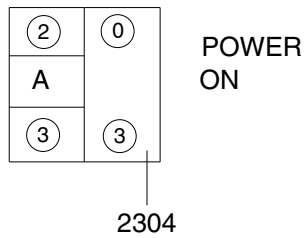
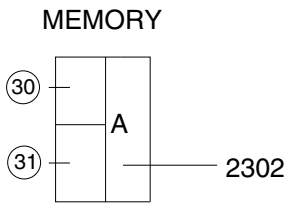
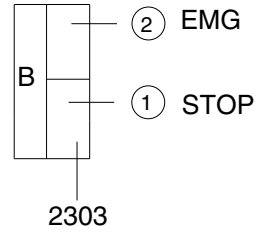
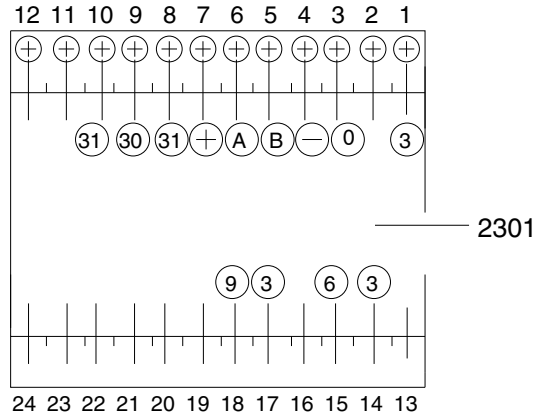

Electrical System Parts 2

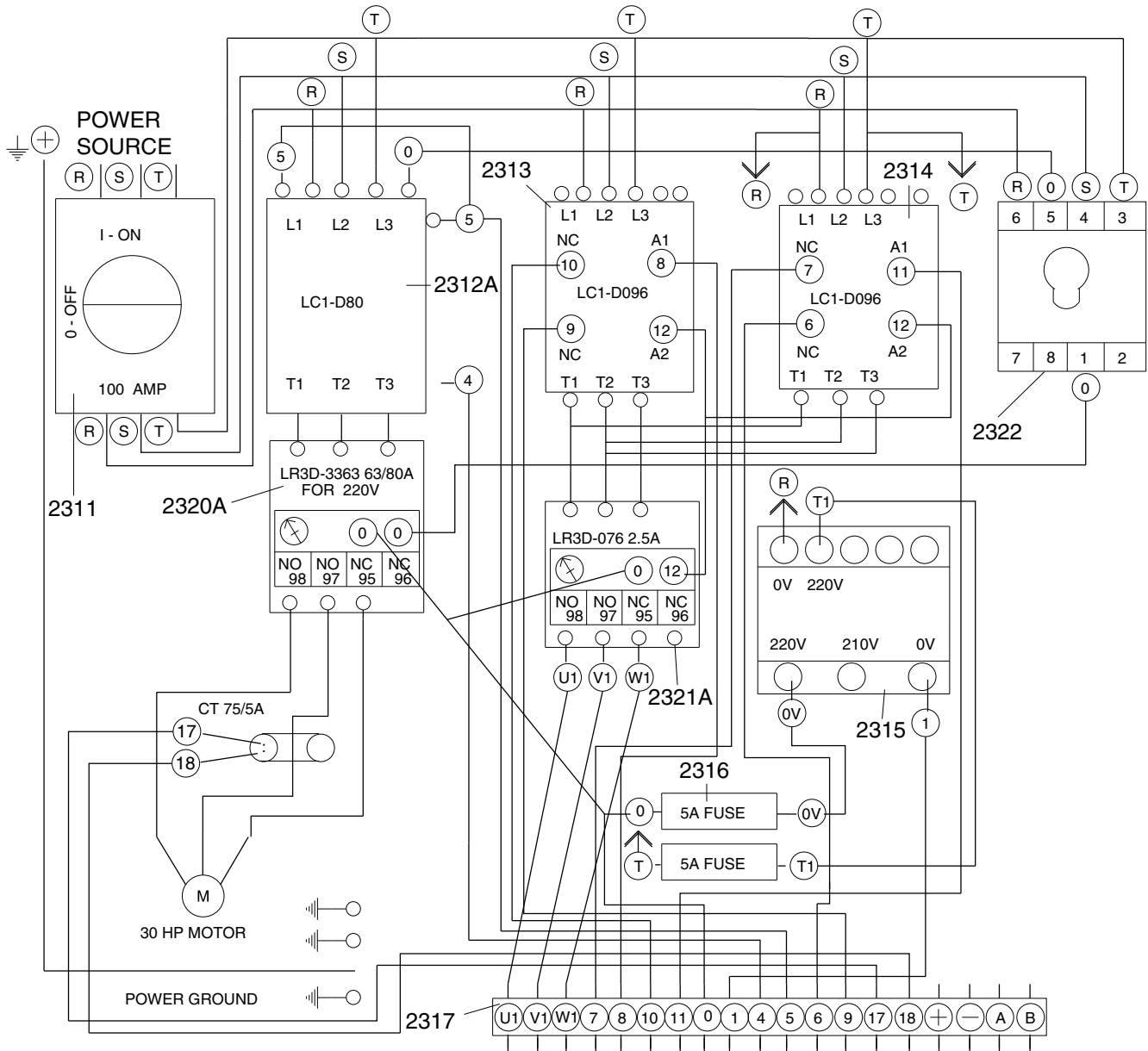

440V CONVERSION KIT = 2319A
 OVERLOAD RELAY
 LR3D-3357 37/50A FOR 440V

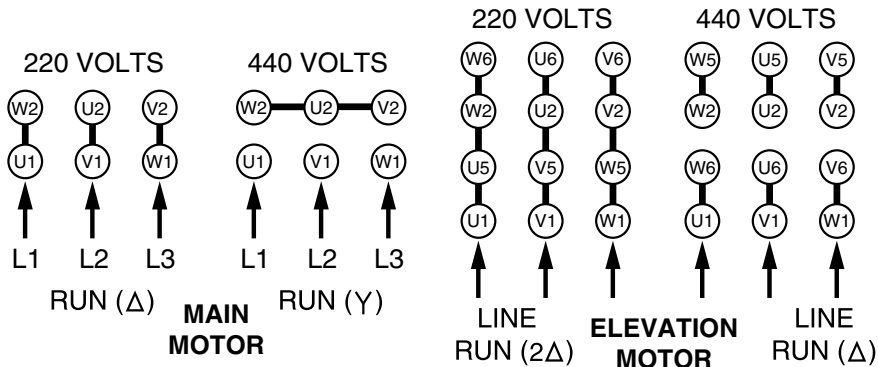
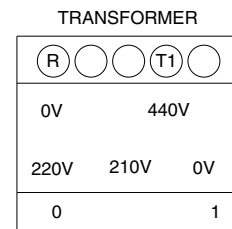
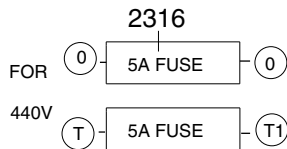

Electrical System Parts List

REF	PART #	DESCRIPTION
2301	P05042301	DIMENSION SET METER FPC-525/INCH
2302	P05042302	MEMORY BUTTON N/S
2303	P05042303	EMERGENCY BUTTON N/S
2304	P05042304	POWER ON BUTTON N/S
2305	P05042305	UP/LIMIT SWITCH
2306	P05042306	UP BUTTON N/S
2307	P05042307	MOTOR START/GREEN N/S
2308	P05042308	DOWN/LIMIT SWITCH
2309	P05042309	DOWN BUTTON N/S
2310	P05042310	MOTOR STOP/RED N/S
2311	P05042311	NO FUSE SWITCH 3P 100AMP
2312A	P05042312A	MAG.CONTACTOR LCI-D080 (TE)
2313	P05042313	MAG.CONTACTOR LCI-D096 (TE)
2314	P05042313	MAG.CONTACTOR LCI-D096 (TE)
2315	P05042315	TRANSFORMER 200VA
2316	P05042316	FUSE 5A FUSE
2317	P05042317	ELECTRIC SET 10A/1P
2318	P05042318	POWER SAFETY SWITCH
2319A	P05042319A	440V CONVERSION KIT (TE 30HP)
2320A	P05042320A	OL RELAY 220V LR3D-3363 63/80A
2321A	P05042321A	UP OL RELAY LR3D-076 2.5A
2322	P05042322	PHASE REVERSAL RELAY



WARRANTY CARD

Name _____
 Street _____
 City _____ State _____ Zip _____
 Phone # _____ Email _____ Invoice # _____
 Model # _____ Order # _____ Serial # _____

The following information is given on a voluntary basis. It will be used for marketing purposes to help us develop better products and services. **Of course, all information is strictly confidential.**

1. How did you learn about us?

Advertisement Friend Catalog
 Card Deck Website Other:

2. Which of the following magazines do you subscribe to?

<input type="checkbox"/> Cabinet Maker	<input type="checkbox"/> Popular Mechanics	<input type="checkbox"/> Today's Homeowner
<input type="checkbox"/> Family Handyman	<input type="checkbox"/> Popular Science	<input type="checkbox"/> Wood
<input type="checkbox"/> Hand Loader	<input type="checkbox"/> Popular Woodworking	<input type="checkbox"/> Wooden Boat
<input type="checkbox"/> Handy	<input type="checkbox"/> Practical Homeowner	<input type="checkbox"/> Woodshop News
<input type="checkbox"/> Home Shop Machinist	<input type="checkbox"/> Precision Shooter	<input type="checkbox"/> Woodsmith
<input type="checkbox"/> Journal of Light Cont.	<input type="checkbox"/> Projects in Metal	<input type="checkbox"/> Woodwork
<input type="checkbox"/> Live Steam	<input type="checkbox"/> RC Modeler	<input type="checkbox"/> Woodworker West
<input type="checkbox"/> Model Airplane News	<input type="checkbox"/> Rifle	<input type="checkbox"/> Woodworker's Journal
<input type="checkbox"/> Modeltec	<input type="checkbox"/> Shop Notes	<input type="checkbox"/> Other:
<input type="checkbox"/> Old House Journal	<input type="checkbox"/> Shotgun News	

3. What is your annual household income?

\$20,000-\$29,000 \$30,000-\$39,000 \$40,000-\$49,000
 \$50,000-\$59,000 \$60,000-\$69,000 \$70,000+

4. What is your age group?

20-29 30-39 40-49
 50-59 60-69 70+

5. How long have you been a woodworker/metalworker?

0-2 Years 2-8 Years 8-20 Years 20+ Years

6. How many of your machines or tools are Grizzly?

0-2 3-5 6-9 10+

7. Do you think your machine represents a good value?

Yes No

8. Would you recommend Grizzly Industrial to a friend?

Yes No

9. Would you allow us to use your name as a reference for Grizzly customers in your area?

Note: We never use names more than 3 times. Yes No

10. Comments: _____

CUT ALONG DOTTED LINE

FOLD ALONG DOTTED LINE



Place
Stamp
Here



GRIZZLY INDUSTRIAL, INC.
P.O. BOX 2069
BELLINGHAM, WA 98227-2069



FOLD ALONG DOTTED LINE

Send a Grizzly Catalog to a friend:

Name _____
Street _____
City _____ State _____ Zip _____

TAPE ALONG EDGES--PLEASE DO NOT STAPLE

WARRANTY AND RETURNS

Grizzly Industrial, Inc. warrants every product it sells for a period of **1 year** to the original purchaser from the date of purchase. This warranty does not apply to defects due directly or indirectly to misuse, abuse, negligence, accidents, repairs or alterations or lack of maintenance. This is Grizzly's sole written warranty and any and all warranties that may be implied by law, including any merchantability or fitness, for any particular purpose, are hereby limited to the duration of this written warranty. We do not warrant or represent that the merchandise complies with the provisions of any law or acts unless the manufacturer so warrants. In no event shall Grizzly's liability under this warranty exceed the purchase price paid for the product and any legal actions brought against Grizzly shall be tried in the State of Washington, County of Whatcom.

We shall in no event be liable for death, injuries to persons or property or for incidental, contingent, special, or consequential damages arising from the use of our products.

To take advantage of this warranty, contact us by mail or phone and give us all the details. We will then issue you a "Return Number," which must be clearly posted on the outside as well as the inside of the carton. We will not accept any item back without this number. Proof of purchase must accompany the merchandise.

The manufacturers reserve the right to change specifications at any time because they constantly strive to achieve better quality equipment. We make every effort to ensure that our products meet high quality and durability standards and we hope you never need to use this warranty.

Please feel free to write or call us if you have any questions about the machine or the manual.

Thank you again for your business and continued support. We hope to serve you again soon.

grizzly.com

TOOL WEBSITE

Buy Direct and Save with Grizzly® – Trusted, Proven and a Great Value!

*Visit Our Website Today And Discover
Why Grizzly® Is The Industry Leader!*

- SECURE ORDERING
- ORDERS SHIPPED WITHIN 24 HOURS
- E-MAIL RESPONSE WITHIN ONE HOUR

-OR-

Call Today For A **FREE**
Full Color Catalog

1-800-523-4777

