

Grizzly *Industrial, Inc.*®

12" SLIDING TABLE SAW MODEL G0588/G0591 INSTRUCTION MANUAL



COPYRIGHT © MAY, 2005 BY GRIZZLY INDUSTRIAL, INC. REVISED SEPTEMBER, 2012 (ST)

**WARNING: NO PORTION OF THIS MANUAL MAY BE REPRODUCED IN ANY SHAPE
OR FORM WITHOUT THE WRITTEN APPROVAL OF GRIZZLY INDUSTRIAL, INC.**

#EW7041 PRINTED IN TAIWAN

WARNING

Some dust created by power sanding, sawing, grinding, drilling, and other construction activities contains chemicals known to the State of California to cause cancer, birth defects or other reproductive harm. Some examples of these chemicals are:

- Lead from lead-based paints.
- Crystalline silica from bricks, cement, and other masonry products.
- Arsenic and chromium from chemically treated lumber.

Your risk from these exposures varies, depending on how often you do this type of work. To reduce your exposure to these chemicals: work in a well ventilated area, and work with approved safety equipment, such as those dust masks that are specially designed to filter out microscopic particles.

Table of Contents

INTRODUCTION	3
Foreword	3
Contact Info	3
Machine Data Sheet.....	4
Identification	5
SECTION 1: SAFETY	7
Safety Instructions for Machinery.....	7
Additional Safety Instructions for Table Saws.....	9
Preventing Kickback.....	10
Protecting Yourself from Kickback	10
Glossary Of Terms	11
SECTION 2: CIRCUIT REQUIREMENTS	12
220V Single-Phase.....	12
220/440V 3-Phase.....	13
Phase Converter	14
Grounding.....	14
Rewiring to 440V	14
SECTION 3: SET UP	16
Set Up Safety	16
Unpacking	16
Items Needed For Set Up	16
Moving & Placing Base Unit.....	17
Site Considerations	17
Clean Up	18
Inventory.....	18
Hardware Recognition Chart.....	20
Extension Tables.....	21
Rip Fence and Scale.....	22
Main Blade	24
Scoring Blade	25
Aligning Blades.....	26
Riving Knife Adjustment	26
Sliding Table.....	28
Sliding Table Parallelism	29
Crosscut Table	30
Crosscut Fence	30
Fence Scale Alignment	31
Dust Collection	31
Power Cord	32
Test Run.....	32

SECTION 4: OPERATIONS	33
Operation Safety	33
Operation Tips.....	33
Changing Blades.....	34
Rip Cutting.....	35
Crosscutting	37
Miter Cutting.....	39
SECTION 5: ACCESSORIES.....	40
SECTION 6: MAINTENANCE.....	43
Schedule	43
Cleaning	43
Unpainted Cast Iron	43
Lubrication.....	44
SECTION 7: SERVICE	45
About Service.....	45
Replacing Belts	45
Blade Tilt	47
Squaring Crosscut Fence to Blade	48
Electrical.....	49
Troubleshooting.....	50
SECTION 8: PARTS.....	52
Main Body	53
Extension Tables.....	55
Sliding Table.....	57
Crosscut Table	59
Crosscut Fence	61
Rip Fence.....	63
Trunnion Assembly.....	65
Motor Assembly.....	67
Arbor Assembly.....	69
WARRANTY AND RETURNS	70

INTRODUCTION

Foreword

We are proud to offer the Model G0588/G0591 12" Sliding Table Saws. These machines are part of a growing Grizzly family of fine woodworking machinery. When used according to the guidelines set forth in this manual, you can expect years of trouble-free, enjoyable operation and proof of Grizzly's commitment to customer satisfaction.

We are pleased to provide this manual with the Model G0588/G0591. It was written to guide you through assembly, review safety considerations, and cover general operating procedures. It represents our effort to produce the best documentation possible.

The specifications, drawings, and photographs illustrated in this manual represent the Model G0588/G0591 as supplied when the manual was prepared. However, owing to Grizzly's policy of continuous improvement, changes may be made at any time with no obligation on the part of Grizzly. For your convenience, we always keep current Grizzly manuals available on our website at **www.grizzly.com**. Any updates to your machine will be reflected in these manuals as soon as they are complete. Visit our site often to check for the latest updates to this manual!



Contact Info

If you have any comments regarding this manual, please write to us at the address below:

Grizzly Industrial, Inc.
c/o Technical Documentation
P.O. Box 2069
Bellingham, WA 98227-2069

We stand behind our machines. If you have any service questions or parts requests, please call or write us at the location listed below.

Grizzly Industrial, Inc.
1203 Lycoming Mall Circle
Muncy, PA 17756
Phone: (570) 546-9663
Fax: (800) 438-5901
E-Mail: techsupport@grizzly.com
Web Site: <http://www.grizzly.com>





MACHINE DATA SHEET

Customer Service #: (570) 546-9663 • To Order Call: (800) 523-4777 • Fax #: (800) 438-5901

MODEL G0588/G0591 12" Sliding Table Saws

Overall Dimensions:

Overall Size.....	140" W (192" w/Cross Slide Fence Extended) x 126" D (270" w/Sliding Table Extended) x 48" H
Table Height.....	36"
Table Size (w/Extension Wings).....	65" W x 59" D
Sliding Table Size.....	13¾" W x 118" D
Machine Net Weight.....	1140 lbs.
Machine Shipping Weight.....	1430 lbs.
Crate 1 Size.....	89⅞" W x 40½" D x 44" H
Crate 2 Size.....	131⅜" W x 17" D x 11⅞" H
Base Footprint (w/Extension Leg).....	79" W x 74" D

Capacities:

Main Blade Diameter.....	12" (305mm)
Scoring Blade Diameter.....	3⅛" (80mm)
Maximum Depth of Cut at 90°.....	3⅛"
Maximum Depth of Cut at 45°.....	2¾"
Blade Tilt.....	0-45°
Table w/Rip Fence Max Cutting Width.....	48"
Sliding Table w/Cross Fence Max Cut Width.....	126"
Sliding Table w/Cross Fence Max Cut Length.....	118"

Construction:

Sliding Table.....	Aluminum
Machine Frame.....	Steel
Fence.....	Extruded Aluminum
Rails.....	Chromed Steel
Trunnions.....	Cast Iron

Motor:

G0588 Motor.....	7½ HP, 220/440V (Prewired 220V), 20/10A, 3-Phase
G0591 Motor.....	5 HP, 220V, 22A, Single-Phase
Motor RPM.....	3450 RPM
Main Blade Arbor.....	1"
Main Blade Arbor Speed.....	4900 RPM
Scoring Blade Arbor.....	20mm
Scoring Arbor Speed.....	9000 RPM
Ball Bearings.....	Shielded & Lubricated
Power Transfer.....	Belt Drive
Switch.....	Magnetic w/Thermal Overload Protection

Features:

.....	Blade Guard w/2½" Dust Port
.....	5" Main Dust Port
.....	Adjustable Scoring Knife Kerf
.....	Adjustable Riving Knife
.....	Micro Adjustable, Single Lever Locking Fence

Specifications, while deemed accurate, are not guaranteed.

Identification

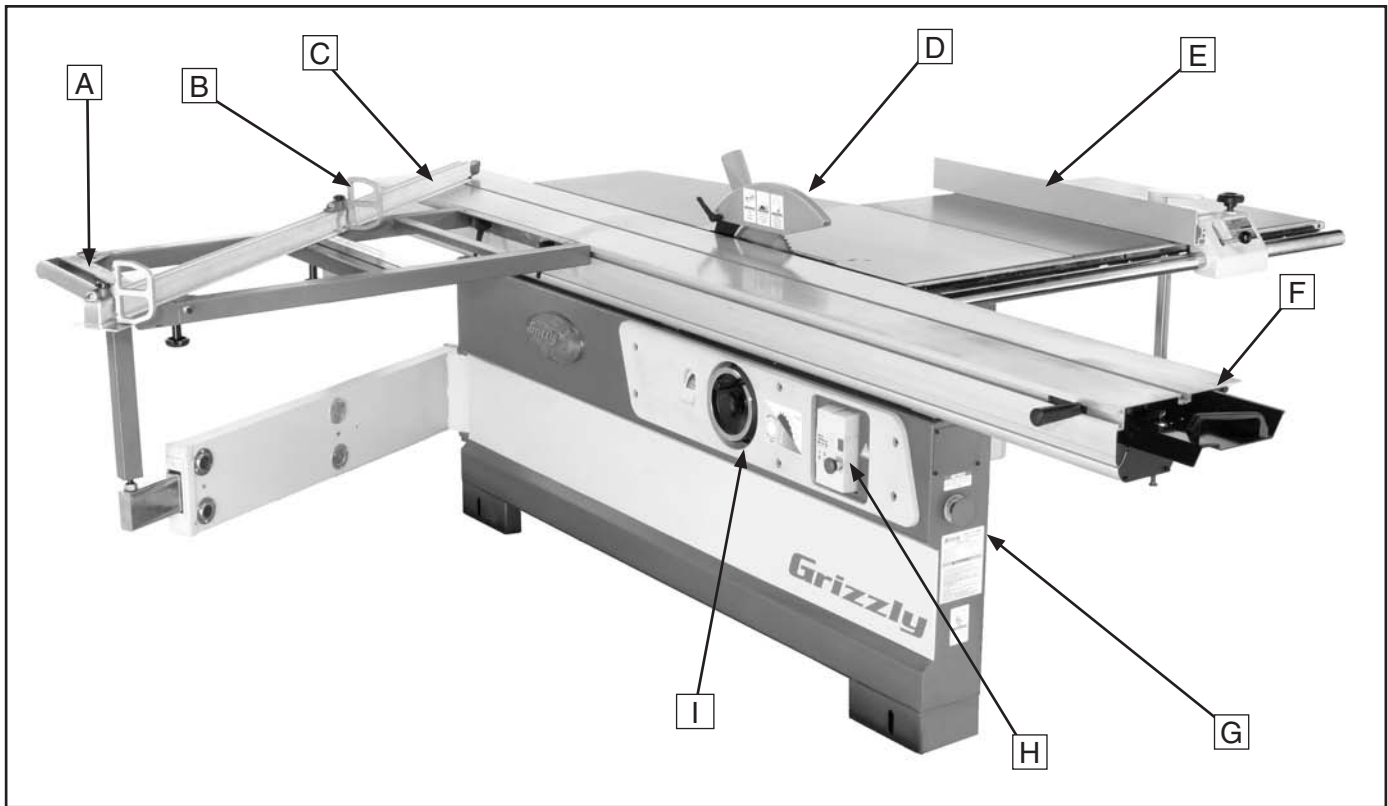

Figure 1. Main view of machine features and controls.

- A. Crosscut Table:** Provides a wide, stable platform for supporting full-size panels during crosscutting operations.
- B. Flip Stops:** Used for quick measurements for crosscutting.
- C. Crosscut Fence:** Used during crosscutting operations. Features a scale and multiple flip-style stop blocks for precise, repeatable crosscutting operations.
- D. Blade Guard:** Fully-adjustable blade guard maintains maximum protection around the saw blade and a 2½" dust port effectively extracts dust from the cutting operation.
- E. Rip Fence:** Fully adjustable with micro-adjustment knob for precision adjustments. Fence face can be positioned for standard cutting operations, or in the lower position for blade guard clearance during narrow ripping operations.
- F. Sliding Table:** Conveniently glides the workpiece through the blade with effortless precision and ease.
- G. EMERGENCY STOP Button:** Turns the motor **OFF** when pushed.
- H. Power ON/OFF Buttons:** Turns the main and scoring blades **ON** or **OFF**.
- I. Blade Angle Handwheel:** Adjusts the angle of the saw blades.

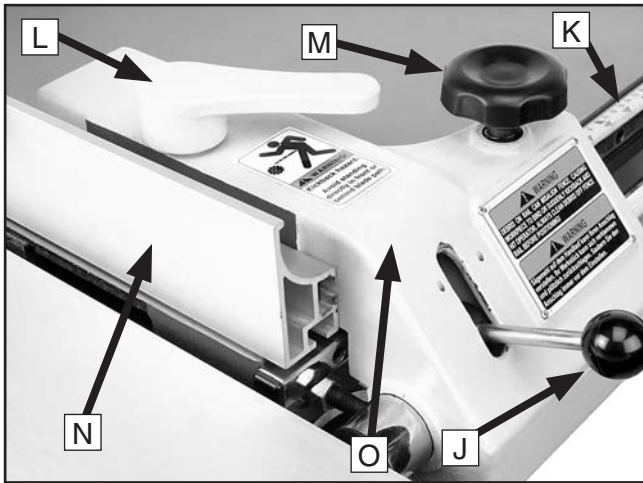

Figure 2. Fence controls.

- J. Rip Fence Body Lock Lever:** Secures the fence body in position along the fence rail.
- K. Rip Fence Scale:** Allows precise measurement of rip cutting operations.
- L. Rip Fence Lock Handle:** Secures the fence face on its forward/backward slide track.
- M. Micro-Adjust Knob:** Precisely adjusts the fence.
- N. Fence Face:** The surface that the workpiece slides along.
- O. Fence Body:** Guides the fence along the rail and supports the fence face.

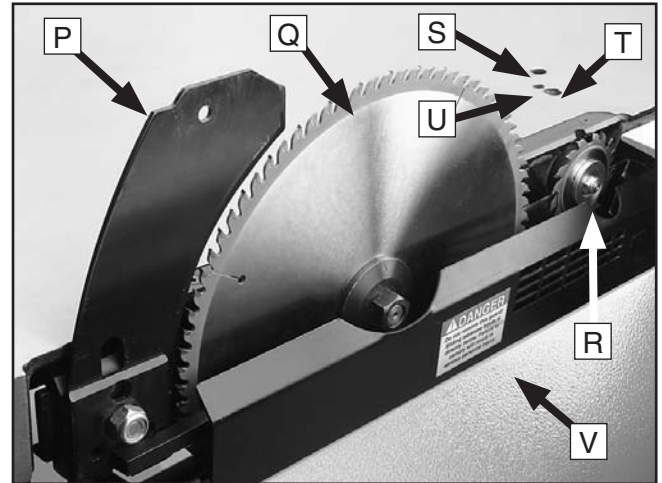

Figure 3. Blades.

- P. Riving Knife:** Maintains kerf opening during cutting operations. This function is crucial to preventing kickback caused by the kerf closing behind the blade.
- Q. Main Blade (Not Included):** Performs the cutting operations.
- R. Scoring Blade (Not Included):** Small cutting blade that rotates opposite the main saw blade. The blade scores the workpiece before the actual cutting operation is performed preventing tear-out in laminate materials. The scoring blade is adjustable left and right, up and down, and in thickness of kerf.
- S. Scoring Blade Vertical Adjustment Socket:** Internal cap screw adjusts the height of the scoring blade.
- T. Scoring Blade Horizontal Adjustment Socket:** Internal cap screw adjusts the horizontal position of the scoring blade in relation to the main blade.
- U. Scoring Blade Lock Socket:** Locks the scoring blade adjustments.
- V. Lower Blade Guard:** Prevents accidental contact with the blade when the table is at its full extension.

SECTION 1: SAFETY

WARNING

For Your Own Safety, Read Instruction Manual Before Operating this Machine

The purpose of safety symbols is to attract your attention to possible hazardous conditions. This manual uses a series of symbols and signal words which are intended to convey the level of importance of the safety messages. The progression of symbols is described below. Remember that safety messages by themselves do not eliminate danger and are not a substitute for proper accident prevention measures.



Indicates an imminently hazardous situation which, if not avoided, **WILL** result in death or serious injury.



Indicates a potentially hazardous situation which, if not avoided, **COULD** result in death or serious injury.



Indicates a potentially hazardous situation which, if not avoided, **MAY** result in minor or moderate injury. It may also be used to alert against unsafe practices.

NOTICE

This symbol is used to alert the user to useful information about proper operation of the machine.

WARNING

Safety Instructions for Machinery

- 1. READ THROUGH THE ENTIRE MANUAL BEFORE STARTING MACHINERY.** Machinery presents serious injury hazards to untrained users.
- 2. ALWAYS USE ANSI APPROVED SAFETY GLASSES WHEN OPERATING MACHINERY.** Everyday eyeglasses only have impact resistant lenses, they are NOT safety glasses.
- 3. ALWAYS WEAR AN ANSI APPROVED RESPIRATOR WHEN OPERATING MACHINERY THAT PRODUCES DUST.** Wood dust is a carcinogen and can cause cancer and severe respiratory illnesses.
- 4. ALWAYS USE HEARING PROTECTION WHEN OPERATING MACHINERY.** Machinery noise can cause permanent hearing damage.
- 5. WEAR PROPER APPAREL. DO NOT** wear loose clothing, gloves, neckties, rings, or jewelry which may get caught in moving parts. Wear protective hair covering to contain long hair and wear non-slip footwear.
- 6. NEVER OPERATE MACHINERY WHEN TIRED, OR UNDER THE INFLUENCE OF DRUGS OR ALCOHOL.** Be mentally alert at all times when running machinery.

WARNING

Safety Instructions for Machinery

7. **ONLY ALLOW TRAINED AND PROPERLY SUPERVISED PERSONNEL TO OPERATE MACHINERY.** Make sure operation instructions are safe and clearly understood.
8. **KEEP CHILDREN AND VISITORS AWAY.** Keep all children and visitors a safe distance from the work area.
9. **MAKE WORKSHOP CHILD PROOF.** Use padlocks, master switches, and remove start switch keys.
10. **NEVER LEAVE WHEN MACHINE IS RUNNING.** Turn power **OFF** and allow all moving parts to come to a complete stop before leaving machine unattended.
11. **DO NOT USE IN DANGEROUS ENVIRONMENTS.** DO NOT use machinery in damp, wet locations, or where any flammable or noxious fumes may exist.
12. **KEEP WORK AREA CLEAN AND WELL LIT.** Clutter and dark shadows may cause accidents.
13. **USE A GROUNDED EXTENSION CORD RATED FOR THE MACHINE AMPERAGE.** Undersized cords overheat and lose power. Replace extension cords if they become damaged. DO NOT use extension cords for 220V machinery.
14. **ALWAYS DISCONNECT FROM POWER SOURCE BEFORE SERVICING MACHINERY.** Make sure switch is in OFF position before reconnecting.
15. **MAINTAIN MACHINERY WITH CARE.** Keep blades sharp and clean for best and safest performance. Follow instructions for lubricating and changing accessories.
16. **MAKE SURE GUARDS ARE IN PLACE AND WORK CORRECTLY BEFORE USING MACHINERY.**
17. **REMOVE ADJUSTING KEYS AND WRENCHES.** Make a habit of checking for keys and adjusting wrenches before turning machinery **ON**.
18. **CHECK FOR DAMAGED PARTS BEFORE USING MACHINERY.** Check for binding and alignment of parts, broken parts, part mounting, loose bolts, and any other conditions that may affect machine operation. Repair or replace damaged parts.
19. **USE RECOMMENDED ACCESSORIES.** Refer to the instruction manual for recommended accessories. The use of improper accessories may cause risk of injury.
20. **DO NOT FORCE MACHINERY.** Work at the speed for which the machine or accessory was designed.
21. **SECURE WORKPIECE.** Use clamps or a vise to hold the workpiece when practical. A secured workpiece protects your hands and frees both hands to operate the machine.
22. **DO NOT OVERREACH.** Keep proper footing and balance at all times.
23. **MANY MACHINES WILL EJECT THE WORKPIECE TOWARD THE OPERATOR.** Know and avoid conditions that cause the workpiece to "kickback."
24. **ALWAYS LOCK MOBILE BASES (IF USED) BEFORE OPERATING MACHINERY.**
25. **BE AWARE THAT CERTAIN WOODS MAY CAUSE AN ALLERGIC REACTION** in people and animals, especially when exposed to fine dust. Make sure you know what type of wood dust you will be exposed to and always wear an approved respirator.

WARNING

Safety Instructions for Sliding Table Saws

- 1. SAFETY ACCESSORIES.** Always use the blade guard and riving knife on all "through-sawing" operations. *Through-sawing operations are those when the blade cuts completely through the workpiece.*
- 2. KICKBACK.** Kickback is defined as high speed expulsion of stock from the table saw toward the operator. *Until you have a clear understanding of kickback and how it occurs, DO NOT operate this table saw!*
- 3. WORKPIECE CONTROL.** Make sure the workpiece is placed in a stable position on the table and is either supported by the rip fence or the crosscut table during cutting operations.
- 4. PUSH STICK.** Always use a push stick when ripping narrow stock.
- 5. OPERATOR POSITION.** Never stand or have any part of your body directly in-line with the cutting path of the saw blade.
- 6. REACHING OVER SAW BLADE.** Never reach behind or over the blade with either hand while the saw is running. *If kickback occurs while reaching over the blade, hands or arms could be pulled into the spinning saw blade.*
- 7. RIP FENCE USAGE.** When using the crosscut fence, the workpiece should never contact the rip fence while the saw blade is cutting.
- 8. STALLED BLADE.** Turn the saw **OFF** before "freeing" a stalled saw blade.
- 9. AWKWARD OPERATIONS.** Avoid awkward operations and hand positions where a sudden slip could cause your hand to move into the spinning saw blade.
- 10. BLADE HEIGHT.** Always adjust the blade to the proper height above the workpiece.
- 11. DAMAGED SAW BLADES.** Never use blades that have been dropped or damaged. A damaged blade could lose teeth while turning, causing injury or death.
- 12. RIVING KNIFE ALIGNMENT.** Only operate the saw if the riving knife is aligned with the main blade to prevent kickback.
- 13. EXPERIENCING DIFFICULTIES.** If at any time you are experiencing difficulties performing the intended operation, stop using the machine! Contact Tech Support at (570) 546-9663.

WARNING

Like all machines there is danger associated with the Model G0588/G0591. Accidents are frequently caused by lack of familiarity or failure to pay attention. Use this machine with respect and caution to lessen the possibility of operator injury. If normal safety precautions are overlooked or ignored, serious personal injury may occur.

CAUTION

No list of safety guidelines can be complete. Every shop environment is different. Always consider safety first, as it applies to your individual working conditions. Use this and other machinery with caution and respect. Failure to do so could result in serious personal injury, damage to equipment, or poor work results.

WARNING

Statistics prove that most common accidents among table saw users can be linked to kickback. Kickback is typically defined as the high-speed expulsion of stock from the table saw toward its operator. In addition to the danger of the operator or others in the area being struck by the flying stock, the operator's hands can be pulled into the blade during the kickback.

Preventing Kickback

Below are tips to reduce the likelihood of kickback:

- Never attempt freehand cuts. If the workpiece is not fed perfectly parallel with the blade, a kickback will likely occur. Always use the rip fence or crosscut fence to support the workpiece.
- Make sure the riving knife is always aligned with the blade. A misaligned riving knife can cause the workpiece to bind or stop the flow of the cut, resulting in an increased chance of kickback. If you think that your riving knife is not aligned with the blade, check it immediately!
- Ensure that your table slides parallel with the blade; otherwise, the chances of kickback are extreme. Take the time to check and adjust the sliding table.
- Use the riving knife whenever performing a through cut. The riving knife helps maintain the kerf in the workpiece after it is cut, therefore, reducing the chance of kickback.
- Keep the blade guard installed and in good working order. Only remove it when performing non-through cuts and immediately re-install the blade guard when finished with the non-through cut.

- Make multiple, shallow passes when performing a non-through cut. Making a deep non-through cut will greatly increase the chance of kickback.
- Feed cuts through to completion. Anytime you stop feeding a workpiece that is in the middle of a cut, the chance of binding, resulting in kickback, is greatly increased.



Protecting Yourself from Kickback

Even if you know how to prevent kickback, it may still happen. Here are some tips to reduce the likelihood of injury if kickback DOES occur:

- Never, for any reason, place your hand behind the blade. Should kickback occur, your hand will be pulled into the blade.
- Stand to the side of the blade during every cut. If a kickback does occur, the thrown workpiece usually travels directly in front of the blade.
- Always wear safety glasses or a face shield. In the event of a kickback, your eyes and face are the most vulnerable part of your body.
- Use a pushstick to keep your hands farther away from the moving blade. If a kickback occurs, the push stick will most likely take the damage that your hand would have received.



Glossary of Terms

The following is a list of common definitions, terms and phrases used throughout this manual as they relate to this table saw and woodworking in general. Become familiar with these terms for assembling, adjusting or operating this machine. Your safety is **VERY** important to us at Grizzly!

Arbor: A metal shaft extending from the drive mechanism that is the mounting location for the saw blade.

Bevel Edge Cut: Tilting the arbor and saw blade to an angle between 0° and 45° to cut a beveled edge onto a workpiece.

Blade Guard: Metal or plastic safety device that mounts over the saw blade. Its function is to prevent the operator from coming into contact with the saw blade.

Crosscut: Cutting operation in which the cross-cut fence is used to cut across the shortest width of the workpiece.

Dado Blade: Blade or set of blades that are used to cut grooves and rabbets.

Dado Cut: Cutting operation that uses a dado blade to cut a flat bottomed groove into the face of the workpiece.

Featherboard: Safety device used to keep the workpiece against the rip fence and against the table surface.

Kerf: The resulting cut or gap in the workpiece after the saw blade passes through during a cutting operation.

Kickback: An event in which the workpiece is propelled back towards the operator at a high rate of speed.

Parallel: Being an equal distance apart at every point along two given lines or planes (i.e. the rip fence face is parallel to the face of the saw blade).

Non-Through Cut: A sawing operation that requires the removal of the blade guard and riving knife. Dado and rabbet cuts are considered Non-Through Cuts because the blade does not protrude above the top face of the wood stock. Deep Non-Through Cuts must be made with multiple, light passes to reduce chance of kickback. Always remember to re-install the blade guard and riving knife after performing a non-through cut.

Perpendicular: Lines or planes that intersect and form right angles (i.e. the blade is perpendicular to the table surface).

Push Stick: Safety device used to push the workpiece through a cutting operation. Used most often when rip cutting thin workpieces.

Rabbet: Cutting operation that creates an L-shaped channel along the edge of the workpiece.

Riving Knife (Splitter): Metal plate located behind the blade. It maintains the kerf opening in the wood when performing a cutting operation.

Straightedge: A tool used to check the flatness, parallelism, or consistency of a surface(s).

Through Cut: A sawing operation in which the workpiece is completely sawn through.

Rip Cut: Cutting operation in which the rip fence is used to cut across the widest width of the workpiece.



SECTION 2: CIRCUIT REQUIREMENTS

220V Single-Phase

⚠️ WARNING

Serious personal injury could occur if you connect the machine to the power source before you have completed the set up process. **DO NOT** connect the machine to the power source until instructed to do so.

Amperage Draw

The 5 HP motor on the Model G0591 will draw the following amps:

Motor Draw at 220V.....22 Amps

Minimum Circuit Requirements

Only connect your machine to a circuit that meets the requirements below. Check to see if the wires and circuit breaker in your circuit are capable of handling the amperage draw from your machine, as well as any other machines that could be operating on the same circuit. If you are unsure, consult a qualified electrician.

Minimum Circuit Requirement.....25 Amp

Minimum Cord Requirements

Use the following type of cord to connect your machine to power (a cord is not provided):

Cord.....3 wire
Gauge.....10 Gauge

Extension Cords

We do not recommend the use of extension cords on 220V equipment. Instead, arrange the placement of your equipment and the installed wiring to eliminate the need for extension cords.

If you find it absolutely necessary to use an extension cord at 220V with your machine, check with a qualified electrician for the correct sizing, type, and maximum possible length for your needs.

Connection Type

Recommended Plug/Receptacle....NEMA L6-30

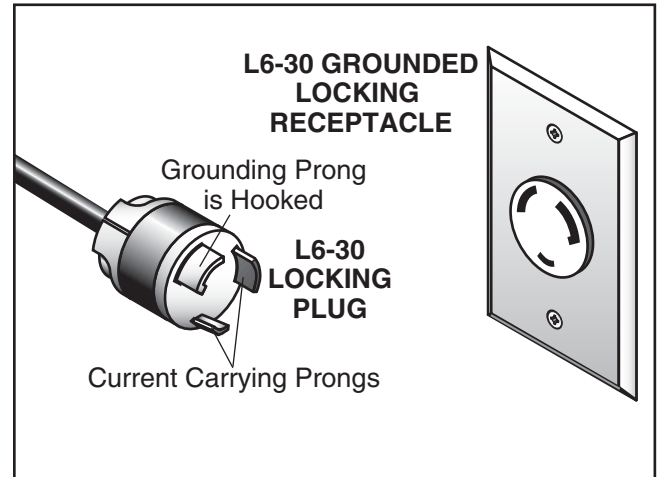
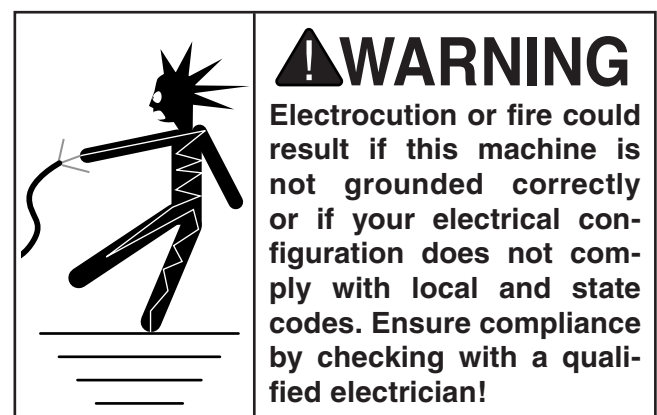

Figure 4. NEMA L6-30 plug and receptacle.

Another option for increased safety is to hardwire your machine directly to the circuit breaker and install a locking shut-off lever near the machine as a way to quickly disconnect the power and prevent accidental starting (see Figure 5).

Grounding

In the event of an electrical short, grounding reduces the risk of electric shock. The grounding wire in the cord must be properly connected to the grounding prong on the plug; likewise, the outlet must be properly installed and grounded. All electrical connections must be made in accordance with local codes and ordinances.



220/440V 3-Phase

⚠️ WARNING

Serious personal injury could occur if you connect your machine to the power source before you have completed the set up process. DO NOT connect the machine to the power source until instructed to do so.

Wiring

The Model G0588 is prewired for 220V 3-phase operation. If 440 voltage is required, rewire the machine according to the instructions on **Page 14** and follow the circuit requirements on this page.

Amperage Draw

The Model G0588 has a 7½ HP main motor that will draw the following amps:

Motor Draw at 220V.....20 Amps
Motor Draw at 440V 10 Amps

Minimum Circuit Requirements

Only connect your machine to a circuit that meets the requirements below. Check to see if the wires and circuit breaker in your circuit are capable of handling the amperage draw from your machine, as well as any other machines that could be operating on the same circuit. If you are unsure, consult a qualified electrician.

220V Circuit.....25 Amp
440V Circuit..... 15 Amp

Minimum Cord Requirements

Use the following type of cord to connect your machine to power (a cord is not provided):

Cord.....4 wire
Gauge.....10 Gauge

Connection Type

We recommend hardwiring 3-phase machines directly to the circuit breaker and installing a locking shut-off lever near the machine as a way to quickly disconnect the power and prevent accidental starting (see **Figure 5**).

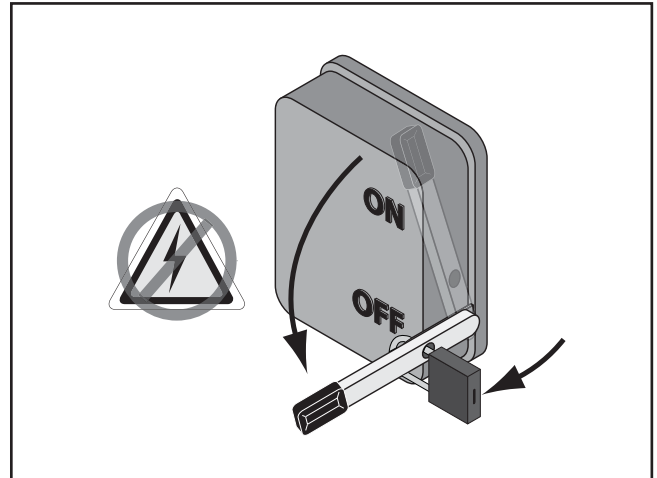

Figure 5. A power disconnect is preferable to high current plugs and receptacles.

⚠️ CAUTION

A fire may occur if your particular electrical configuration does not comply with local and state codes. The best way to ensure compliance is to check with your local municipality or a qualified electrician.



Phase Converter

When using a phase converter, the power from the manufactured power leg (sometimes called the wild wire) can fluctuate. Connect the manufactured power leg to the S terminal to prevent damage to the electrical controls. The wire from the S terminal can handle some fluctuation because it goes directly to the motor. The power going to the R and T terminals goes to the electrical controls and must be consistent to prevent damage. See the instruction manual included with the phase converter for more information.



Grounding

In the event of an electrical short, grounding reduces the risk of electric shock. The grounding wire in the cord must be properly connected to the grounding prong on the plug; likewise, the outlet must be properly installed and grounded. All electrical connections must be made in accordance with local codes and ordinances.

Improper connections of the electrical-grounding conductor increases the risk of electric shock. Check with a qualified electrician or one of our service personnel if you do not understand the grounding instructions, or if you doubt the machine is properly grounded.

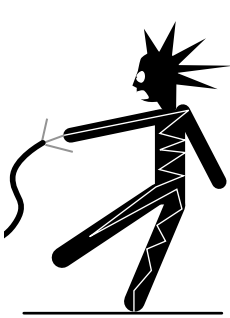
	<p>⚠ WARNING Electrocution or fire could result if this machine is not grounded correctly or if your electrical configuration does not comply with local and state codes. Ensure compliance by checking with a qualified electrician!</p>
---	--



Rewiring to 440V

The Model G0588 can be rewired for 440V operation. This rewiring job consists of disconnecting the saw from the power source, replacing the magnetic switch, and rewiring the motor.

The necessary magnetic switch for this procedure can be purchased by calling our Customer Service number at (800) 523-4777.

This procedure takes moderate electrical skill and the rewiring job must be inspected by a qualified electrician before the saw is connected to the power source.

To rewire the Model G0588 for 440V operation:

- 1. Disconnect the saw from the power source!**
- 2. Remove the control panel cover plate shown in Figure 6.**



Figure 6. Control panel cover plate.

3. Remove the control panel surrounding plate and the cover.
4. Replace the 220V magnetic switch (**Figure 7**) with the 440V magnetic switch. Set the dial on the new overload relay to 11A.

Note: *The magnetic switch consists of the magnetic contactor and the overload relay.*

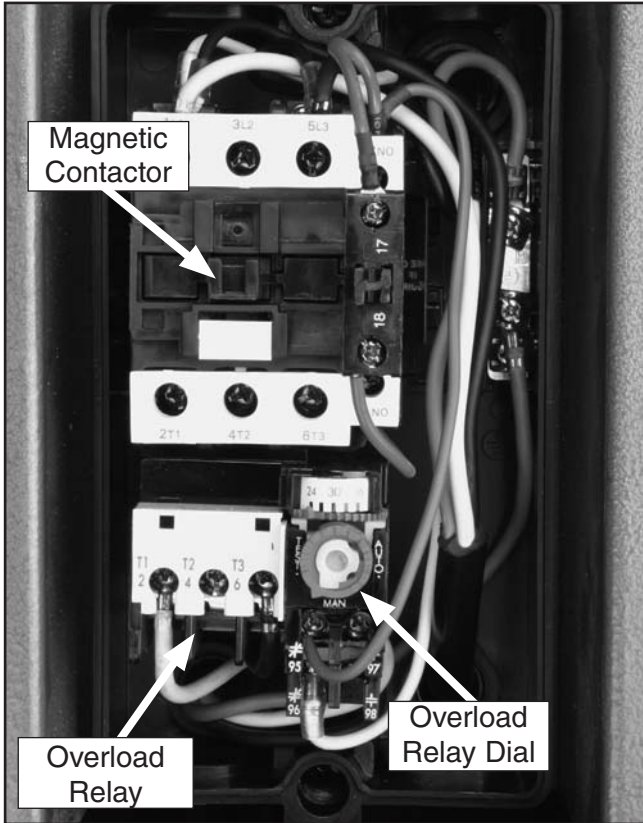

Figure 7. Magnetic switch.

5. Replace the control panel cover, surrounding plate, and the cover plate.

6. Open the motor cabinet door and remove the motor wiring cover (see **Figure 8**).



Figure 8. Motor location.

7. Rewire the motor per the diagram on the inside of the motor wiring cover.



SECTION 3: SET UP

Set Up Safety

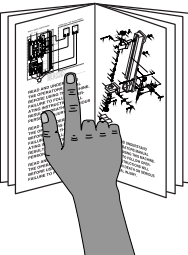

⚠️ WARNING
 This machine presents serious injury hazards to untrained users. Read through this entire manual to become familiar with the controls and operations before starting the machine!



⚠️ WARNING
 Wear safety glasses during the entire set up process!



⚠️ CAUTION
 Unsupervised children and visitors inside your shop could cause serious personal injury to themselves. Lock all entrances to the shop when you are away and **DO NOT** allow unsupervised children or visitors in your shop at any time!

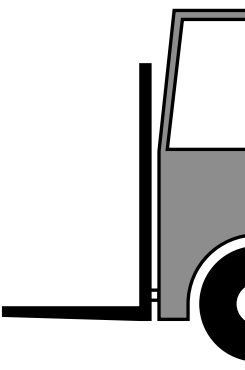

⚠️ WARNING
 The Model G0588/G0591 is a heavy machine with a shipping weight over 1400 lbs. Serious personal injury may occur if safe moving methods are not followed. To be safe, get assistance and use power equipment when moving the crate and removing the machine from the crate.



Unpacking

The Model G0588/G0591 was carefully packed when it left our warehouse. If you discover the machine is damaged after you have signed for delivery, *please immediately call Customer Service at (570) 546-9663 for advice.*

Save the containers and all packing materials for possible inspection by the carrier or its agent. *Otherwise, filing a freight claim can be difficult.*

When you are completely satisfied with the condition of your shipment, you should inventory the contents.



Items Needed for Set Up

The following items are needed to complete the set up, but are not included with your machine:

Description	Qty
• Safety Glasses (for each person)	1
• Power Lifting Equipment	1
• Lifting Straps (1500 lb capacity).....	2
• An Assistant	1
• Main Blade 12" (305mm).....	1
• Scoring Blade 3" (80mm)	1
• Phillips Head Screwdriver	1
• Dial Indicator, or an Adjustable Square and Feeler Gauges	1
• Felt Tip Pen.....	1
• Right Angle Square	1
• Dust Collection System	1
• 5" Dust Hose and Hose Clamps	1
• 2½" Dust Hose and Hose Clamps	1
• Power Cord (length as needed)	1
• Power Disconnect Box	1



Moving & Placing Base Unit

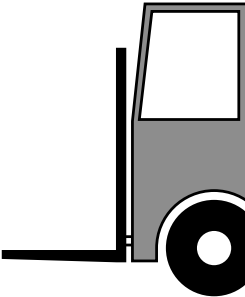

!WARNING
The Model G0588/G0591 is a heavy machine with a shipping weight over 1400 lbs. Serious personal injury may occur if safe moving methods are not followed. To be safe, get assistance and use power equipment when moving the crate and removing the machine from the crate.

!WARNING
Use lifting straps with a minimum of 1500 lbs. lifting capacity. If the lifting strap breaks, serious personal injury may occur.

To remove the saw base unit from the crate pallet:

1. Remove the top of the crate and position the forklift forks together and directly above the saw.
2. Place two lifting straps with hooks on the ends over the forks and slide the hooks into the points shown in **Figure 9**.



Figure 9. Lifting the saw base unit.

!WARNING
DO NOT lift the table saw any higher than necessary to clear the floor. Serious personal injury and damage to the machine may occur if safe moving methods are not followed.

3. Lift the saw base unit and move it to your predetermined location.



Site Considerations

Floor Load

The G0588/G0591 weighs 1140 lbs. and has a base footprint of 79" W x 74" D. Most commercial floors are suitable for this machine. Residential floors may require additional reinforcement to support the machine and operator.

Working Clearances

Consider existing and anticipated needs, size of material to be processed through your machine, and space for auxiliary stands, work tables or other machinery when establishing a location for your saw. See **Figure 10** for the minimum working clearances of the Model G0588/G0591.

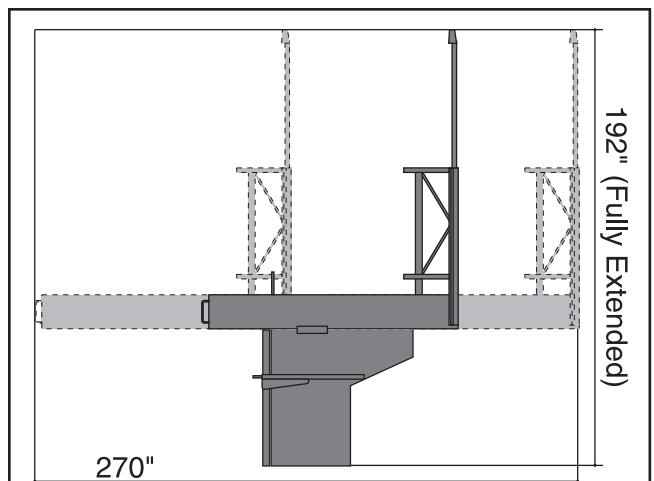

Figure 10. Working clearances.



Clean Up

The unpainted surfaces are coated with a waxy oil to protect them from corrosion during shipment. Remove this protective coating with a solvent cleaner or citrus-based degreaser such as Grizzly's G7895 Degreaser. To clean thoroughly, some parts may need to be removed. **For optimum performance from your machine, make sure you clean all moving parts or sliding contact surfaces that are coated.** Avoid chlorine-based solvents, such as acetone or brake parts cleaner, as they may damage painted surfaces should they come in contact. Always follow the manufacturer's instructions when using any type of cleaning product.



⚠️ WARNING

Gasoline and petroleum products have low flash points and could cause an explosion or fire if used to clean machinery. **DO NOT** use gasoline or petroleum products to clean the machinery.

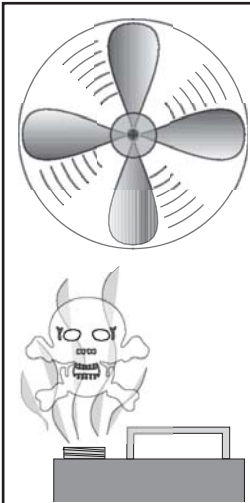

⚠️ CAUTION

Many of the solvents commonly used to clean machinery can be toxic when inhaled or ingested. Lack of ventilation while using these solvents could cause serious personal health risks or fire. Take precautions from this hazard by only using cleaning solvents in a well ventilated area.



Inventory

After all the parts have been removed from the two boxes, you should have the following items:

Crate 1	Qty
A. Saw Base Unit (Not Shown)	1
B. Large Extension Wing	1
C. Small Extension Wing	1
D. Support Leg.....	1

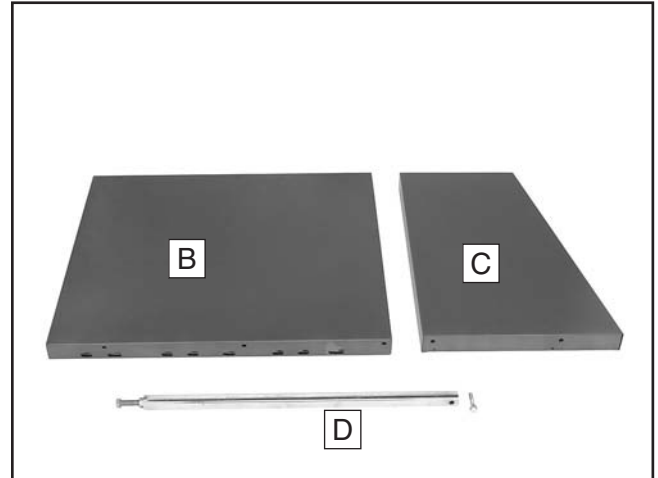

Figure 11. Extension table components.

E. Rip Fence Round Rail w/M12 Studs, Washers, and Nuts.....	1
F. Square Tube w/Scale.....	1
G. Rip Fence Body.....	1
H. Rip Fence Lock Handle.....	1
I. Aluminium Rip Fence	1

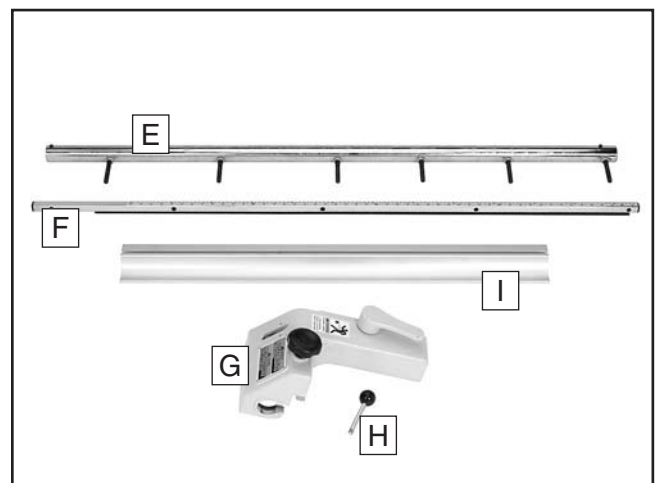

Figure 12. Rip fence components.

- J. Crosscut Table 1
- K. Crosscut Table Lock Plate 1
- L. Adjustable Handles M10-1.5 2
- M. Crosscut Aluminium Fence 1

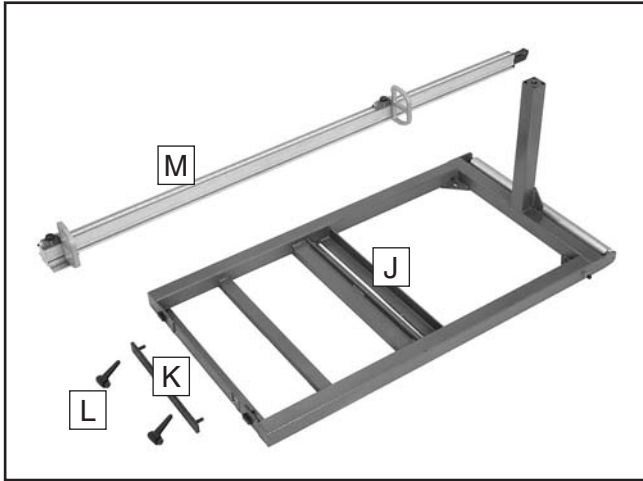

Figure 13. Crosscut table components.

- N. Blade Guard/Dust Hood 1
- O. Adjustable Handle M8-1.25 x 28 1
- P. Riving Knife 1

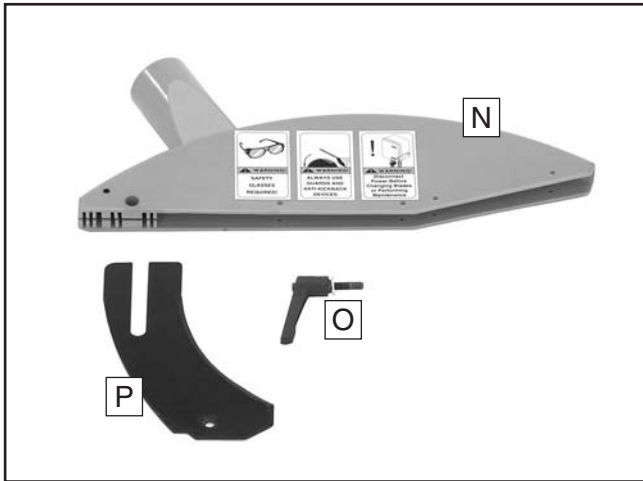

Figure 14. Blade guard components.

- Q. Edge Shoe..... 1
- R. Hold Down..... 1

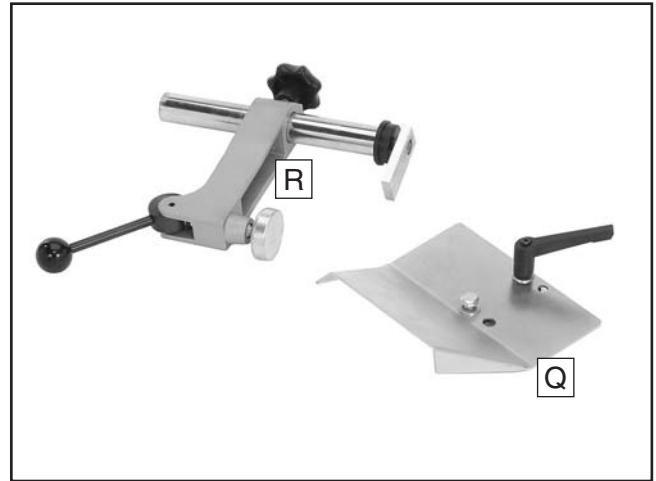

Figure 15. Included accessories.

- Crate 2 Qty
- S. Sliding Table (Not Shown)..... 1

Hardware and Tools

- Hex Bolt M10-1.5 x 45 1
- Hex Nuts M6-1.0 3
- Cap Screws M8-1.25 x 30..... 4
- Cap Screws M6-1.0 x 20..... 5
- Set Screws M8-1.25 x 20 2
- Flat Washer 10mm 3
- Flat Washers 8mm 5
- Flat Washers 6mm 3
- Lock Washers 8mm 4
- Lock Washer 10mm 1
- Flip Stops 2
- Push Handle M14-2 x 16 w/T-Nut..... 1
- Lock Knobs M10-1.5 2
- T-Hex Wrenches 6, 5, 4mm 1 Ea
- Hex Wrenches 6, 3, 2mm 1 Ea
- Open End Wrenches
10/12, 14/17, 22/24mm 1 Ea
- Combo Wrenches 13, 19mm 1 Ea
- Push Stick 1

In the event that any nonproprietary parts are missing (e.g. a nut or a washer), we would be glad to replace them, or for the sake of expediency, replacements can be obtained at your local hardware store.



Hardware Recognition Chart

USE THIS CHART TO MATCH UP HARDWARE DURING THE ASSEMBLY PROCESS.

MEASURE BOLT DIAMETER BY PLACING INSIDE CIRCLE

- #10
- 1/4"
- 5/16"
- 3/8"
- 7/16"
- 1/2"

- 4mm
- 6mm
- 8mm
- 10mm
- 12mm
- 16mm

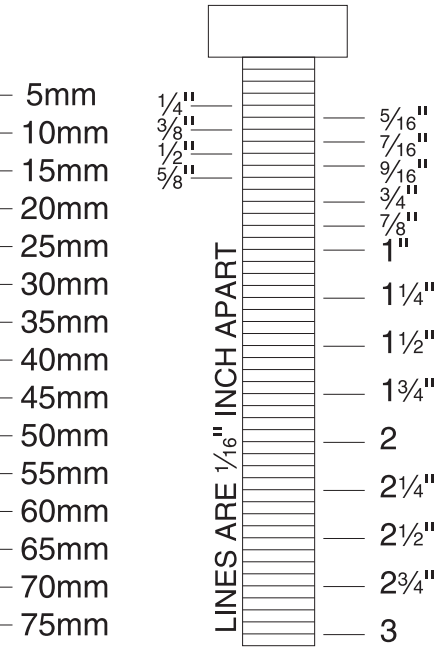
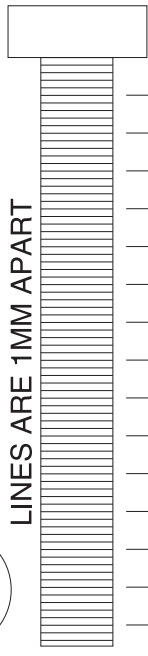
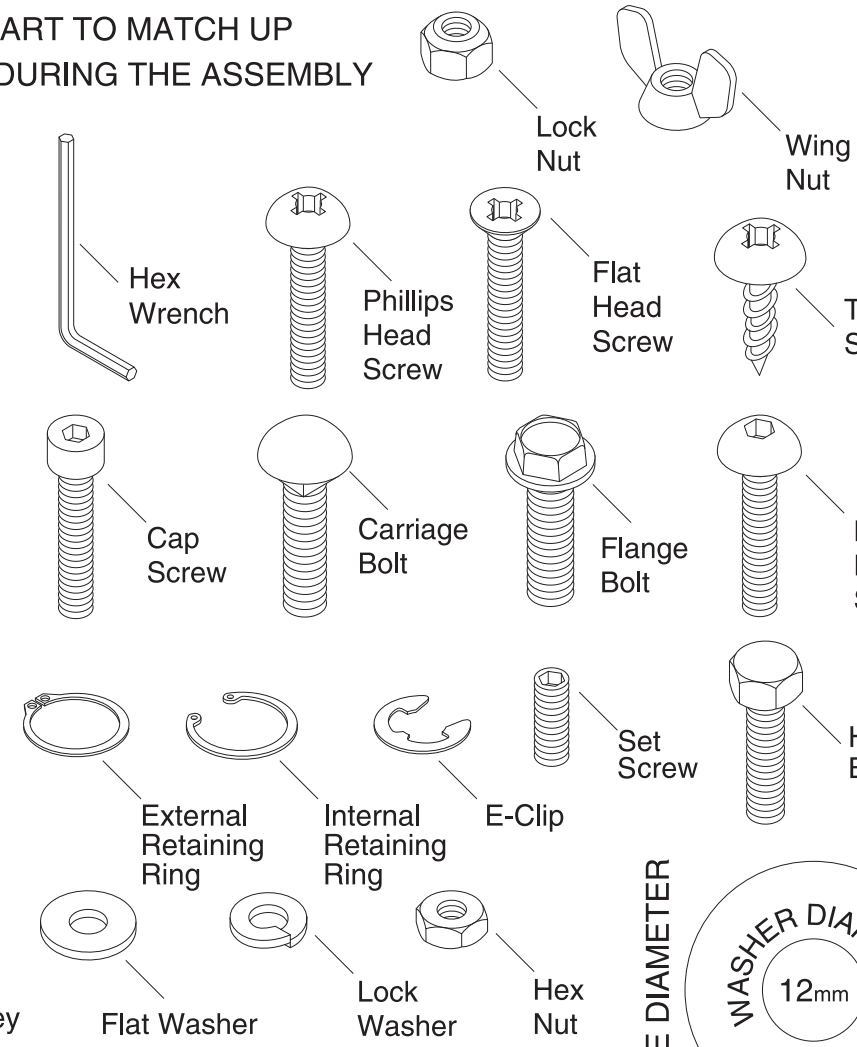

WASHERS ARE MEASURED BY THE INSIDE DIAMETER

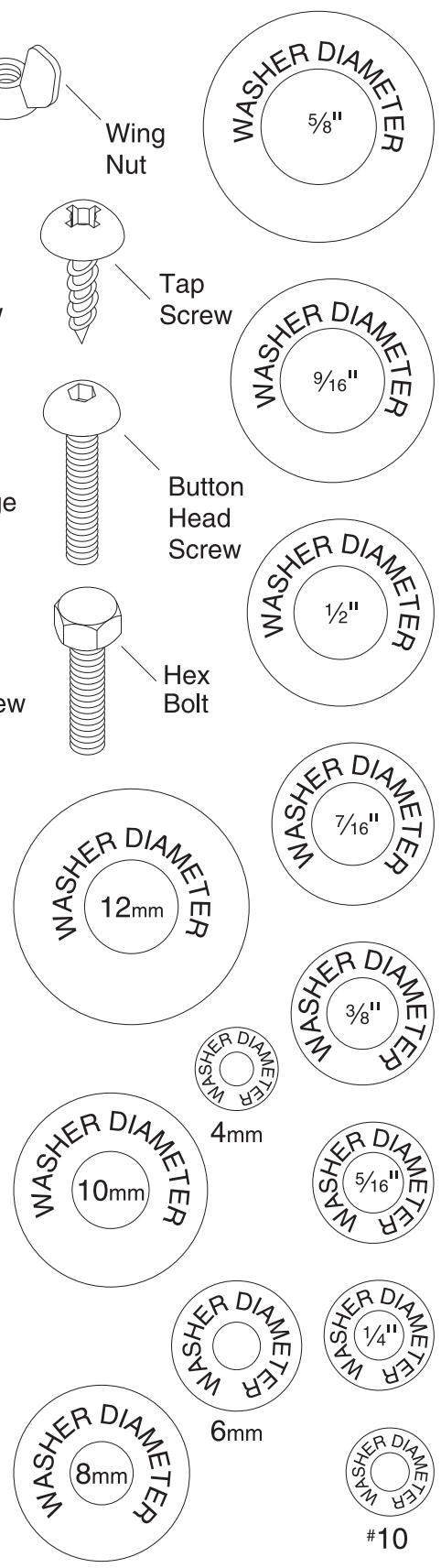

Sliding Table

DO NOT use the sliding table until it is adjusted according to the instructions on **Page 29**. It will not produce accurate cuts until properly adjusted.

Components and Hardware Needed:	Qty
Sliding Table.....	1
Push Handle M14-2 x 16 w/T-Nut.....	1

To install the sliding table:

1. Remove the nuts and washers from the long bolts. DO NOT remove the nuts and washers from the shorter bolts.



2. Lift the sliding table onto the table saw as shown in **Figure 16**.

Note: The long bolts go through the circular holes and the short bolts go into the square holes.



Figure 16. Installing the sliding table.

3. Remove the cover plates shown in **Figure 17** and remove the cover plate under the other end of the sliding table.



Figure 17. Removing cover plates.

4. Thread the washers and nuts removed in **Step 1** onto the long bolts.
5. Slide the T-nut into the sliding table and thread in the handle as shown in **Figure 18**.



Figure 18. Sliding table handles.

6. The sliding table is unlocked when the table lock is in the position shown in **Figure 18**. Rotate the table lock 180° to lock the sliding table.



Extension Tables

Components and Hardware Needed:	Qty
Large Extension Wing	1
Small Extension Wing	1
Support Leg.....	1
Hex Bolt M10-1.5 x 45.....	1
Flat Washer 10mm	1
Lock Washer 10mm.....	1
Cap Screws M8-1.25 x 30.....	4
Set Screws M8-1.25 x 20	2
Lock Washers 8mm.....	4
Flat Washers 8mm	4

To install the extension tables:

1. Thread the set screws into the lower holes in the small extension table. Make sure the set screws do not stick out from the mating surface.

Note: Do not completely tighten the bolts in the following steps until the tables are leveled.

2. Attach the small extension table with two M8-1.25 x 30 cap screws, lock washers, and flat washers as shown in **Figure 19**.

Note: Get assistance positioning the tables and holding them in place while installing.

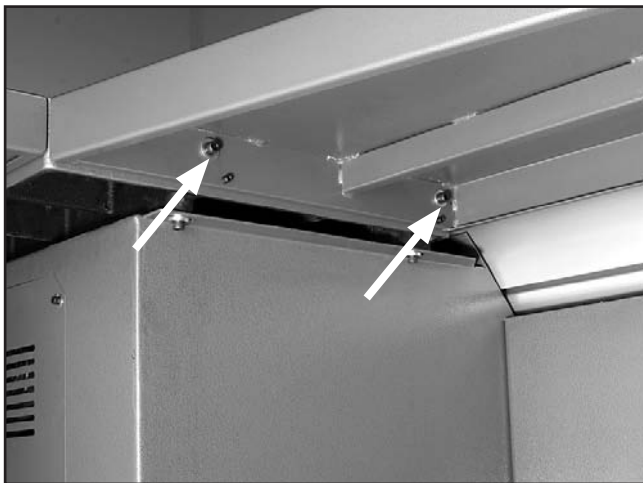

Figure 19. Small extension table attachment.

3. Attach the large extension table with the remaining M8-1.25 x 30 cap screws, lock washers, and flat washers.

4. Attach the support leg (**Figure 20**) to the table with the M10-1.5 x 45 hex bolt, a lock washer, and a flat washer.



Figure 20. Support leg installation.

5. Check the table surfaces with a straightedge as shown in **Figure 21**.

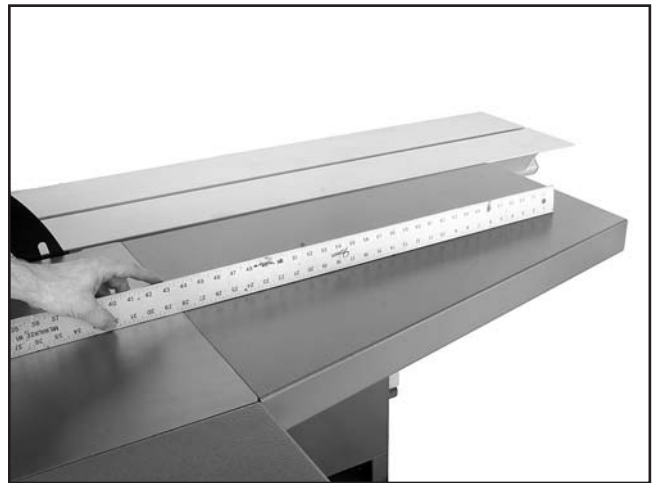

Figure 21. Checking with a straightedge.

6. Adjust the set screws under the small extension table to align the surface with the main table surface.
7. Use the hex bolt in the support leg to level the surface of the large extension table.
8. Tighten all of the cap screws securing the tables.



Rip Fence and Scale

Components and Hardware Needed:	Qty
Aluminium Rip Fence	1
Rip Fence Round Rail	1
Rip Fence Body	1
Rip Fence Lock Handle	1
Square Tube w/Scale	1
Flat Washers 6mm	3
Hex Nuts M6-1	3
Cap Screws M6-1 x 20.....	5

To install the rip fence:

1. Remove a hex nut and a flat washer from each of the studs in the round rail.
2. Insert the studs into the table as shown in **Figure 22**, and loosely secure with the hex nuts and a flat washers removed in **Step 1**.



Figure 22. Installing the round rail.

3. Align the square tube w/scale parallel with the top of the table and secure with the cap screws (see **Figure 23**). Secure the cap screws in the extension table with M6-1 hex nuts and flat washers.

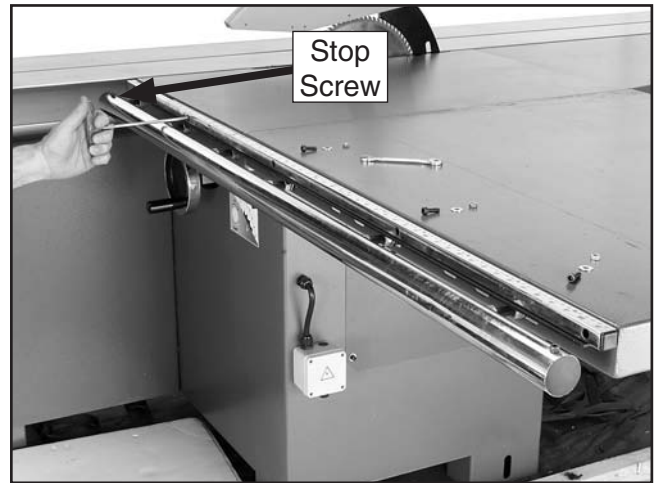

Figure 23. Attaching the scale.

4. Thread the rip fence lock handle into the rip fence body.
5. Remove the stop screw from the left end of the rip fence round rail, slide the rip fence body onto the rail and move it all the way to the left.
6. Adjust the nut shown in **Figure 24** until the teeth of the pinion gear on the underside of the rip fence mesh with the teeth on the square tube. Tighten the hex nut inside the lip of the table to secure the stud.



Figure 24. Aligning the round rail.

- Slide the aluminum rip fence all the way onto the clamping plate (**Figure 25**) and secure it by rotating the locking handle on top of the rip fence body.

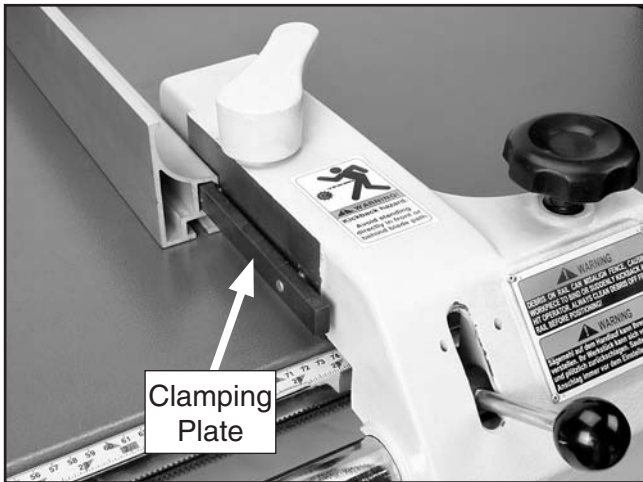

Figure 25. Installing the rip fence.

- Rotate the adjusting nut of the stud on the far right until the rip fence is parallel with the edge of the table as shown in **Figure 26**. Tighten the nut inside the lip of the table to secure the stud, then tighten the outside nut against the adjusting nut.

Note: Leave the center studs loose until the adjustment are complete.

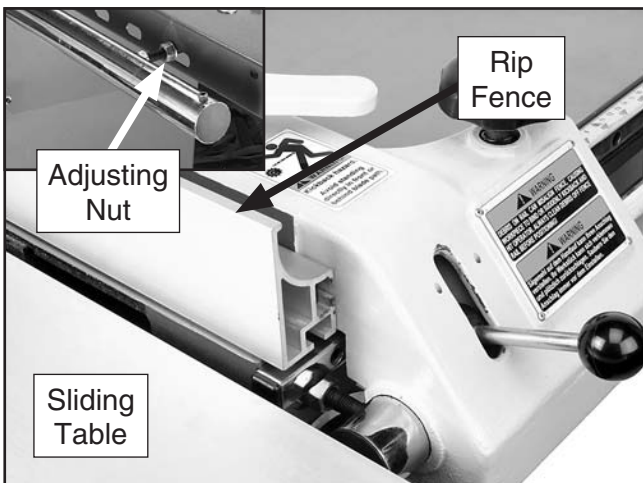

Figure 26. Aligning the fence with the edge of the stationary table.

- Replace the stop screw into the round rail.
- Slide the rip fence along the rail and make sure the gap between the rip fence body and the table is equal along the entire distance.

- Adjust the height of the rip fence rail, then tighten all of the nuts securing the rail against the table (see **Figure 27**) and tighten the outside nuts against the adjusting nuts.



Figure 27. Rip fence rail adjustment nuts.

- Check if the bottom of the rip fence rests on the surface of the table.

—If the rip fence **does not** rest on the table, then the fence is correctly adjusted.

—If the rip fence **does** rest on the table, loosen the hex nut shown in **Figure 28** and rotate the hex bolt to raise the roller. Tighten the hex nut to lock the height.

Note: The rip fence will scratch the table surface if the ride height is not adjusted correctly.

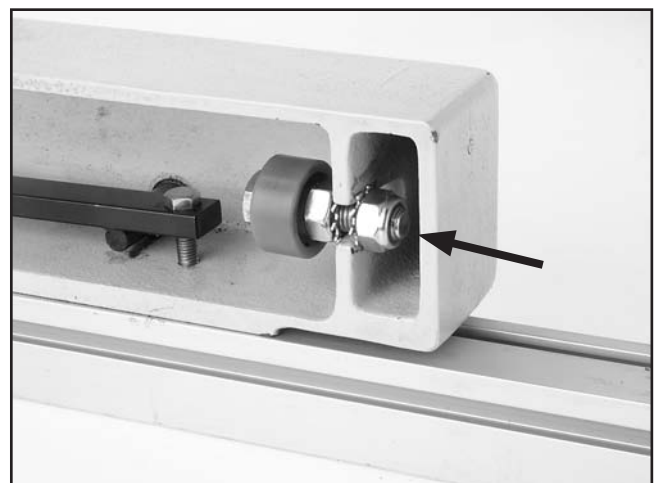

Figure 28. Rip fence height adjustment.



Main Blade

Components and Hardware Needed:	Qty
Blade 12" (Not Included)	1
Riving Knife	1

To install the blade:

1. Move the blade tilt to 0° (blade 90° to table) and raise the main blade arbor.
2. Open the cabinet and remove the foam shipping block and the motor support bracket.
3. Slide the table all the way forward to access the blade arbor, loosen the cap screw securing the lower blade guard, slide the cap screw up, and pull open the lower blade guard (see **Figure 29**).

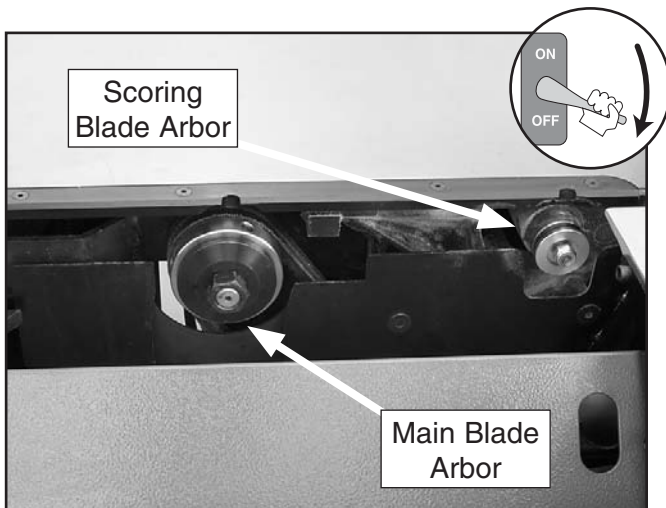

Figure 29. Main blade arbor components.

4. Place a hex wrench in the hole in the arbor to prevent the arbor from rotating, then use the arbor wrench to remove the arbor nut and arbor flange.

Note: The arbor nut has left hand threads and loosens by turning clockwise.

5. Slide the blade onto the arbor with the teeth facing the front of the saw (see **Figure 30**).

Note: Wear gloves to protect your hands when installing or removing blades.

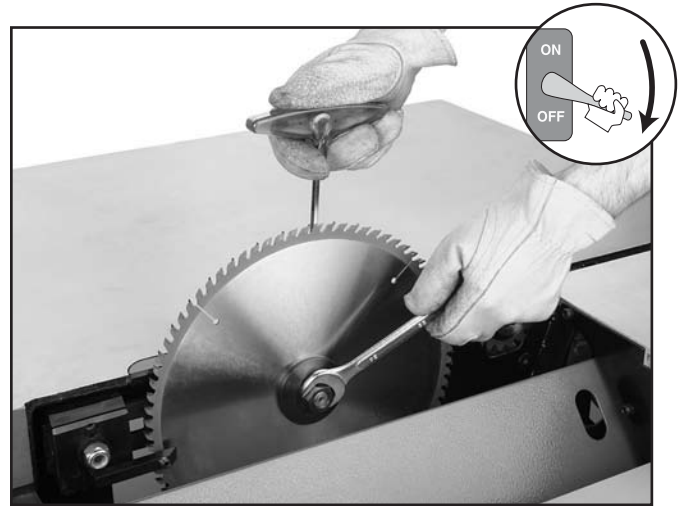

Figure 30. Installing the main blade.

6. Re-install the arbor flange and the arbor nut and tighten them against the blade as shown in **Figure 30**.
7. Loosen the riving knife center bolt, slide the riving knife between the plates as shown in **Figure 31**, and slightly tighten.

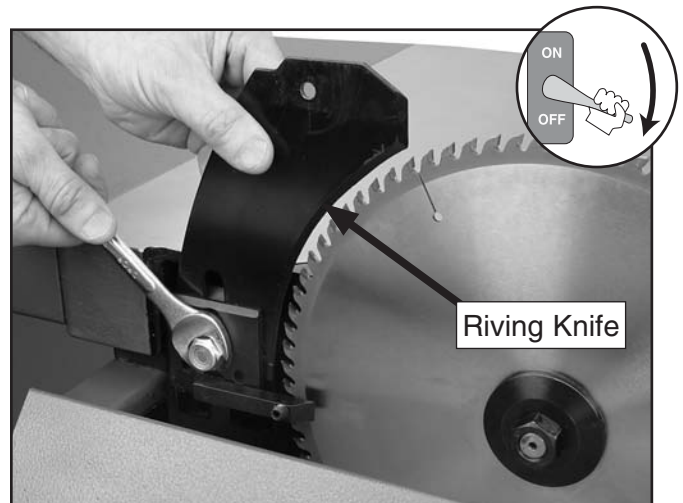

Figure 31. Installing the riving knife.

- Position the riving knife about 3mm or 1/8" away from the nearest carbide tooth on the main blade.

Note: For a quick gauge, use the 3mm hex wrench to find the correct spacing between the blade and the riving knife, as shown in **Figure 32**.

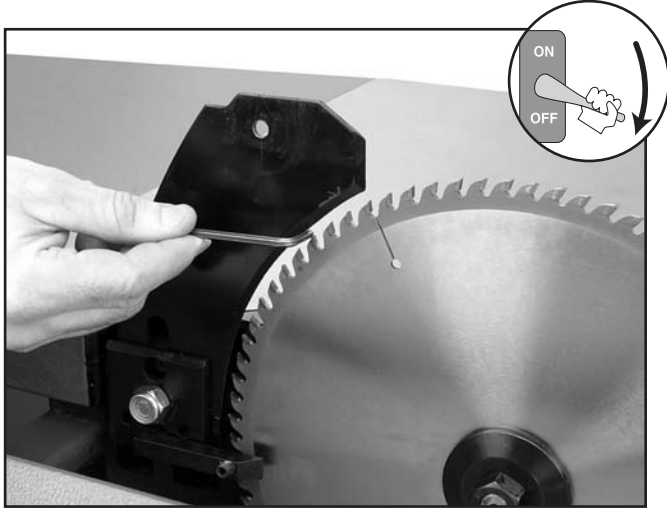

Figure 32. Adjusting the riving knife.

- Tighten the center bolt to secure the riving knife in position.



Scoring Blade

Most scoring blade sets consists of an inner and outer blade and internal shims. The shims are provided so the scoring blade set can match the kerf thickness of the main blade. The requirements for the G0588/G0591 scoring blade are a diameter of 80mm with a 20mm arbor hole.

Components and Hardware Needed: Qty
 Scoring Blade (Not Included) 1

To install the scoring blade:

- Move the blade tilt to 0° (blade 90° to table) and lower the main blade all the way down.
- Slide the table all the way forward to access the blade arbor, loosen the cap screw securing the lower blade guard, slide the cap screw up, and pull open the lower blade guard.

- Measure the thickness of the main blade. Use the shims (**Figure 33**) to stack the scoring blade to the same thickness as the main blade.

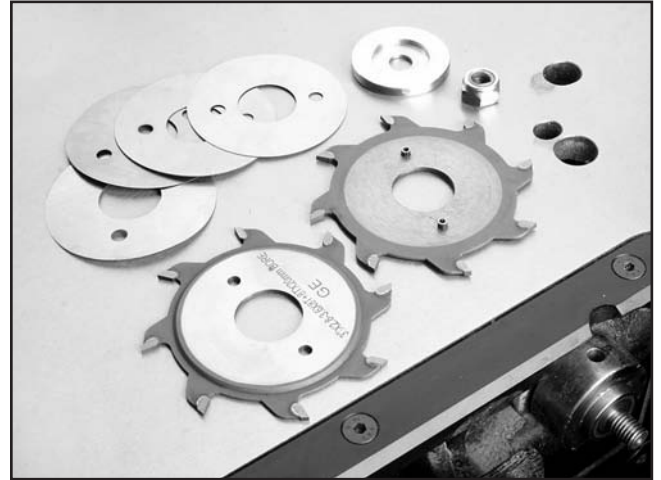

Figure 33. Scoring blade with shims.

- Install the blade set with the teeth facing the back of the saw, and re-install the arbor flange and the arbor nut.
- Place a hex wrench in the hole in the arbor and use the arbor wrench to tighten the arbor nut as shown in **Figure 34**.

Note: The arbor nut has right-hand threads and tightens by turning clockwise.

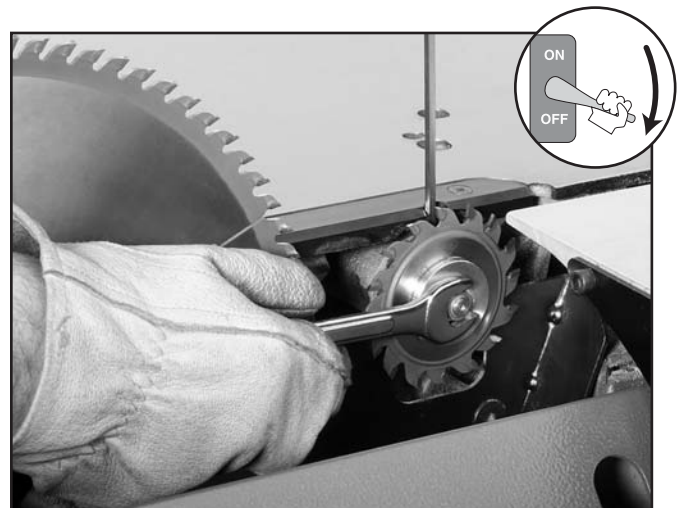

Figure 34. Installing the scoring blade.

- Move the lower blade guard back into its original position and lock it in place with the cap screw.



Aligning Blades

The scoring blade must be aligned with the main blade to ensure satisfactory cutting results.

To align the blades and riving knife:

1. Move the blade tilt to 0° (blade 90° to table), and raise the main blade all the way up.
2. Unlock the scoring blade adjustment using a hex wrench in the adjustment lock socket (**Figure 35**) and raise the blade to its highest point using a hex wrench in the vertical adjustment socket.

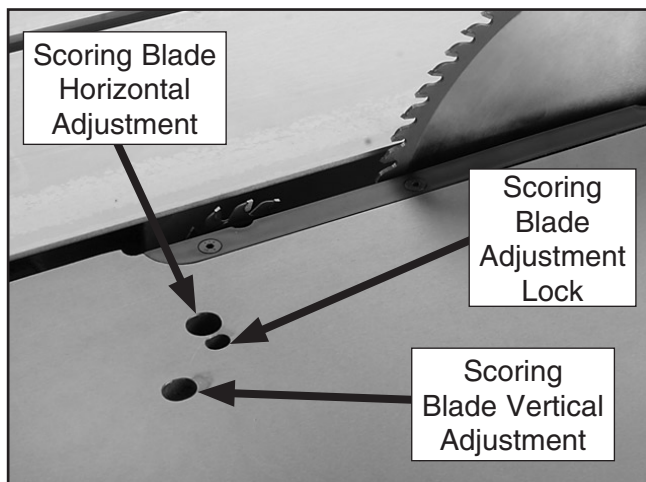

Figure 35. Scoring blade adjustment controls.

3. Remove the stop screw from the round rail and move the rip fence against the blade as shown in **Figure 36**.



Figure 36. Fence against blade as a guide for aligning the scoring blade.

4. Use the adjustment controls to move the scoring blade so that the rip fence can touch both the scoring blade and the main blade and lower the scoring blade to 2mm ($\frac{5}{64}$ ”).
5. Align the riving knife with the center of the main blade as described **on this page**.
6. Replace the stop screw, lock the adjustments, perform a test cut, then make any final adjustments if necessary.



Riving Knife Alignment

To adjust the riving knife:

1. **Disconnect the saw from the power source!**
2. Move the blade tilt to 0° (blade 90° to table), and raise the main blade all the way up.
3. Check both sides of the blade with a straight-edge touching the teeth as shown in **Figure 37**.

—If the straightedge touches the riving knife evenly on both sides, go to **Step 4**.

—If the straightedge only touches the riving knife on one side, go to **Step 5**.

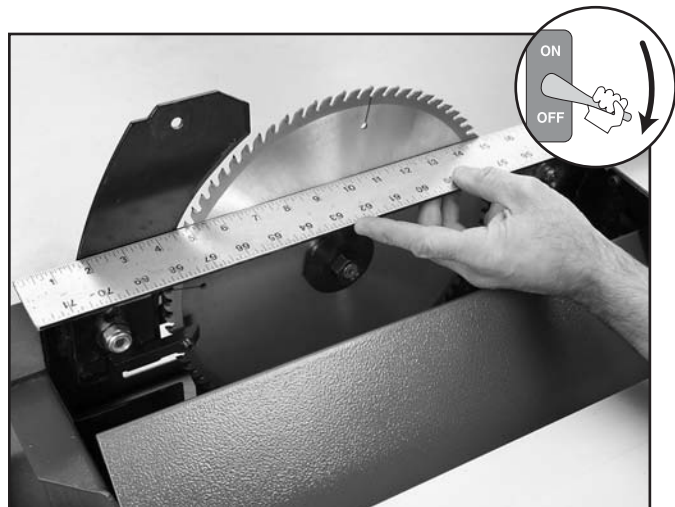

Figure 37. Checking riving knife alignment.

- Place a machinist's square flat on the table and slide it against the riving knife as shown in **Figure 38**.

—If the square lies flat against the riving knife, the riving knife is correctly adjusted.

—If there is a gap between the square and the riving knife, go to **Step 6**.

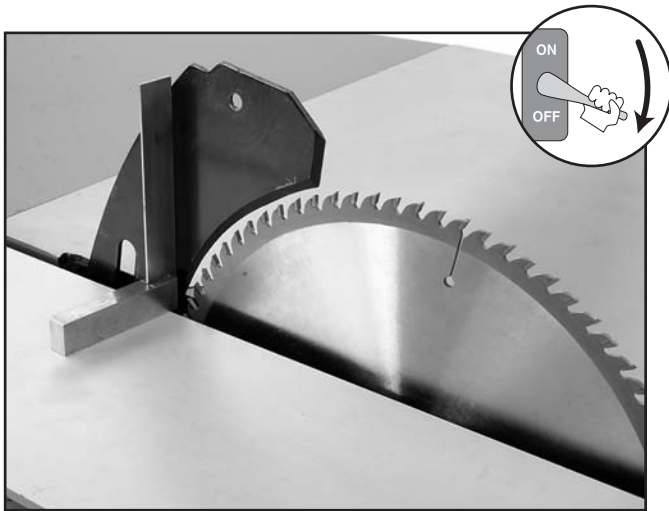

Figure 38. Checking vertical alignment.

- Slide the table all the way forward to access the blade arbor, loosen the cap screw securing the lower blade guard, slide the cap screw up, and pull open the lower blade guard.
- Loosen the riving knife center bolt and remove the riving knife.
- Use the set screws shown in **Figure 39** to adjust the riving knife bracket and re-install the riving knife.

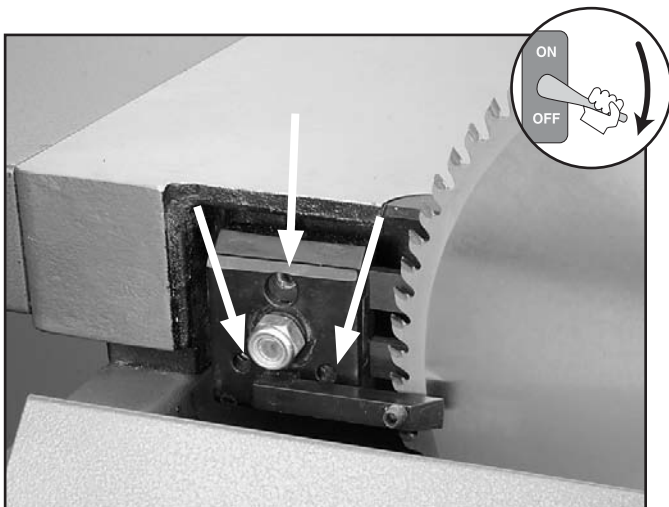

Figure 39. Set screws for adjusting riving knife.

- Repeat **Steps 3-7** until the riving knife is centered on the blade and aligned at 90° to the table.

- Position the riving knife about 3mm or 1/8" away from the nearest carbide tooth on the main blade.

Note: For a quick gauge, use the 3mm hex wrench to find the correct spacing between the blade and the riving knife, as shown in **Figure 40**.

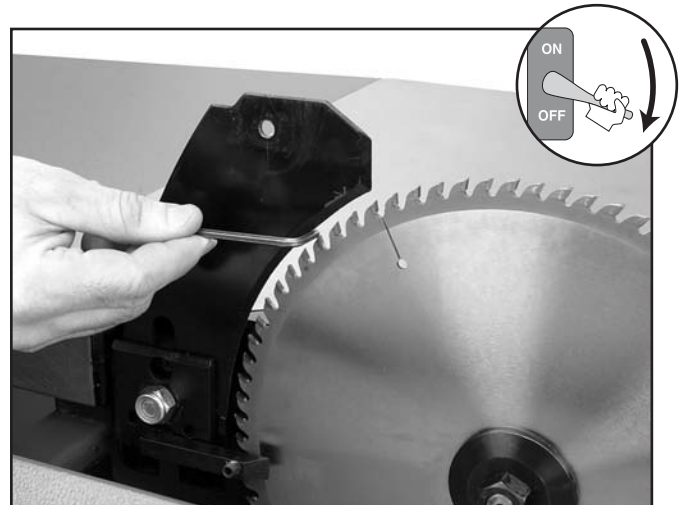

Figure 40. Aligning the riving knife.

- Tighten the center bolt to secure the riving knife in position.
- Move the lower blade guard back to its original position, and move the sliding table back to center.



Sliding Table Parallelism

To adjust the sliding table parallel with the main blade:

1. Move the blade tilt to 0° (blade 90° to table), and raise the main blade as high as it will go.
2. Finger tighten the nut securing the center of the sliding table.
3. Make a mark near the edge of the blade with a felt tip pen. This will allow you to take your measurements from the exact same place on the blade.
4. Using an adjustable square or a dial indicator, measure the distance (A) between the miter slot and the front of the blade as shown in **Figure 41**.

Note: Using a dial indicator will provide the most accurate results.

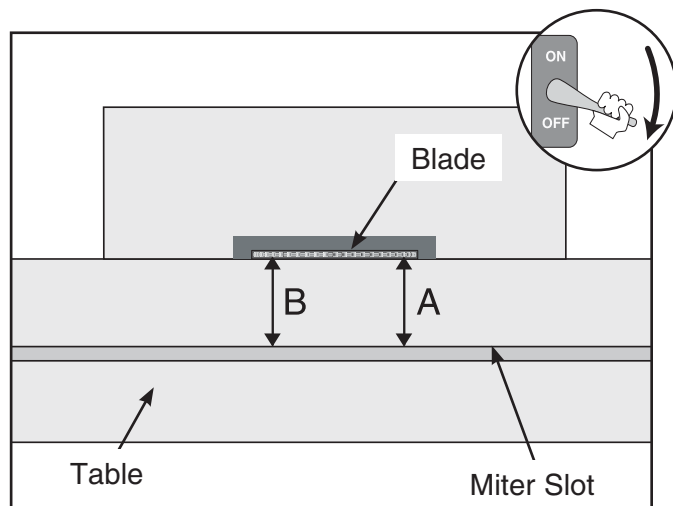

Figure 41. Measuring gap between the table and the blade.

5. Rotate the blade 180° and slide the table with the measuring device to position B.
6. Measure the difference between the two positions (use the feeler gauge if using the adjustable square). Make note of the difference between the two measurements on a piece of paper.

—If the difference was less than 0.004" then the blade parallelism is correct.

—If the difference was greater than 0.004", then the sliding table needs to be adjusted. Continue with the next step.

7. Push the end of the table that is closer to the blade out half the distance noted in **Step 6**.
8. Repeat **Steps 4-7** until the gap between the blade and the sliding table is equal.
9. Tighten the table mounting nuts to secure the sliding table and replace the access plates.



Crosscut Table

Components and Hardware Needed:	Qty
Crosscut Table	1
Crosscut Table Lock Plate.....	1
Adjustable Handles M10-1.5.....	1
Flat Washers 10mm	2

To install the crosscut table:

1. Thread the adjustable handles, with 10mm flat washers, two or three turns onto the studs in the lock plate.
2. Slide the lock plate into the T-slot in the side of the sliding table.
3. With the help of an assistant, place the crosscut table on the pivot pin of the swing arm and over the studs of the lock plate (see **Figure 42**).



Figure 42. Installing the crosscut table.

4. Insert the indexing blocks into the T-slot and lock the crosscut table in place with the adjust levers.



Crosscut Fence

Components and Hardware Needed:	Qty
Crosscut Aluminium Fence	1
Lock Knobs M10-1.5	2
Flip Stops	2

To install the crosscut fence:

1. Insert the T-bolts in the places indicated in **Figure 43**.

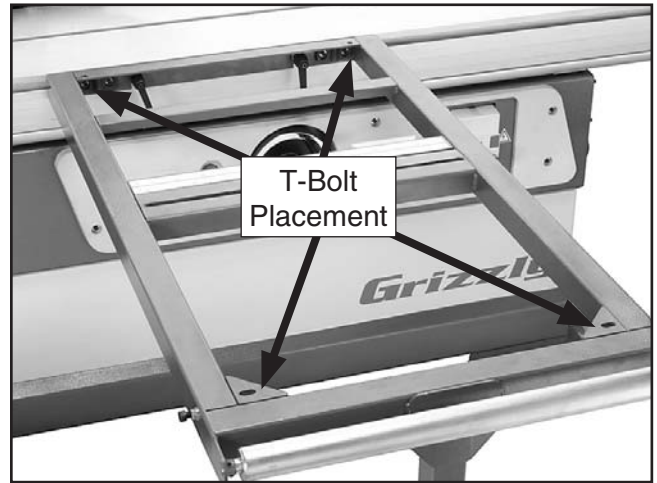

Figure 43. Crosscut fence placement.

2. Place a framing square along the edge of the sliding table and use the crosscut fence adjustment screw (**Figure 44**) to align the fence perpendicular to the sliding table.

Note: Follow the instructions on **Page 48** to make the fence perfectly perpendicular.



Figure 44. Crosscut fence adjustment screw.

3. Thread the knobs onto the T-bolts to secure the crosscut fence.
4. Unlock the fence extension and slide the flip stops into the fence as shown in **Figure 45**.

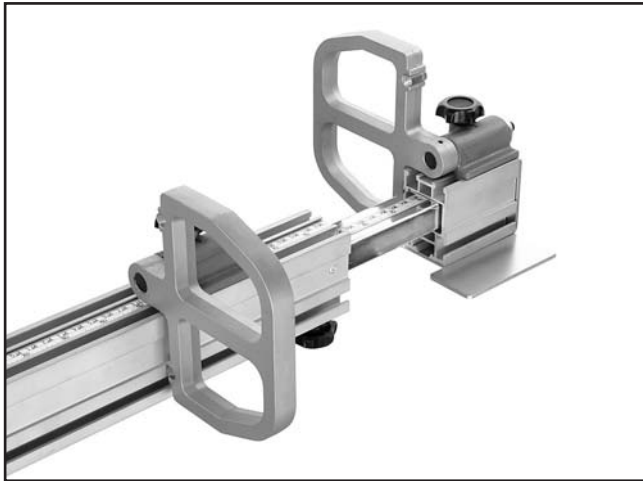

Figure 45. Stop block installation.



Fence Scale Alignment

Before operation, align the 0" mark on the rip fence scale with the right side of the blade to ensure accurate measurements.

To align the fence scale with the blade:

1. Move the blade tilt to 0° (blade 90° to table), and raise the main blade all the way up.
2. Remove the stop screw from the round rail and move the rip fence against the blade.
3. Loosen the cap screws securing the scale.
4. Slide the fence scale to line up the first mark on the scale with the left edge of the rip fence and tighten the cap screws.
5. Slide the fence away from the blade and replace the stop screw.



Dust Collection

Components and Hardware Needed:	Qty
Blade Guard/Dust Hood	1
Flat Washer 8mm	1
Adjustable Handle M8-1.25 x 28	1
5" Dust Hose (not included)	1
5" Hose Clamp (not included)	2
2½" Dust Hose (not included)	1
2½" Hose Clamp (not included)	2
Dust Collection System (not included)	1

To connect the dust ports to a dust collector:

1. Run a 5" hose from the dust collector to the dust port located under the saw table (**Figure 46**) and secure it with hose clamps.

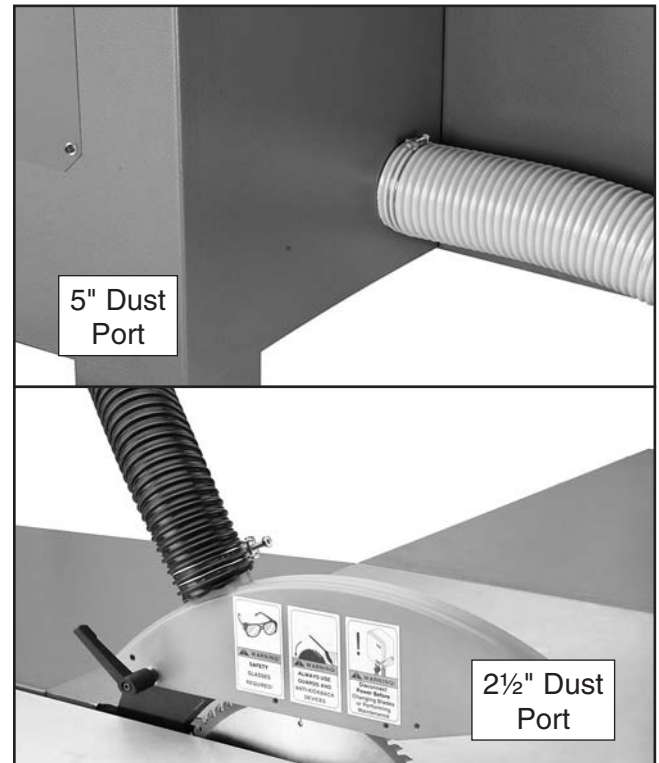

Figure 46. Dust port locations.

2. Install the blade guard/dust hood on the ripping knife with the adjustable handle and flat washer as shown in **Figure 46**.
3. Run a 2½" hose from the dust collector to the blade guard port (**Figure 46**) and secure it with hose clamps.



Power Cord

Before installing the power cord, read through **SECTION 2: CIRCUIT REQUIREMENTS** to check that your setup follows the safety and circuit requirements, and the power cord and power disconnect or plug that you have chosen meet the requirements for this machine.

Components and Hardware Needed:	Qty
Power Cord (Not Included).....	1

To connect the saw to the power source:

1. Open the terminal box shown in **Figure 47**.



Figure 47. G0591 main terminal box.

2. Feed the power cord through the strain relief on the bottom of the box shown in **Figure 47**, tighten the strain relief, connect the cord to the terminals, and close the terminal box.

Note: For Model G0588 only; *When using a phase converter, connect the manufactured power leg to the S terminal. The S terminal can handle power fluctuation because it is wired directly to the motor. The other wires connect to the transformer and must be consistent to prevent damage.*

3. **Shut off the main power at the power source circuit breaker** and install the cord to the disconnect switch or plug.



Test Run

Now that the machine is connected to the power source, it is important to perform a test run to make sure all the controls are working properly.

!WARNING

Before starting the saw, make sure you have performed the preceding assembly and adjustment instructions, and you have read through the rest of the manual and are familiar with the various functions and safety issues associated with this machine. Failure to follow this warning could result in serious personal injury or even death!

To test run the saw:

1. Put on safety glasses and make sure any bystanders are out of the way and also wearing safety glasses.
2. Rotate both of the red EMERGENCY STOP buttons until they spring up.
3. Press the ON button.

—If any problems occur, press the EMERGENCY STOP button.

—For Model G0588 only; If the main blade is rotating in a counterclockwise direction, disconnect the saw from power and exchange wires R & T in the terminal box.

—Investigate and correct the problem before operating the machine further. If you need help, refer to the **Troubleshooting** section in the back of this manual or contact Tech Support at (570) 546-9663.



SECTION 4: OPERATIONS

Operation Safety

WARNING

Damage to your eyes, lungs, and ears could result from using this machine without proper protective gear. Always wear safety glasses, a respirator, and hearing protection when operating this machine.

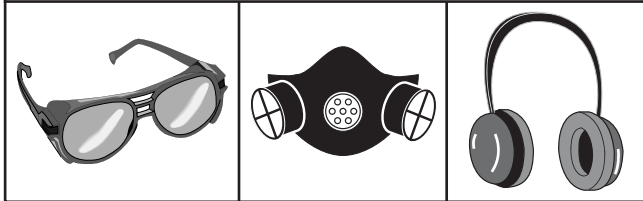

WARNING

Loose hair and clothing could get caught in machinery and cause serious personal injury. Keep loose clothing and long hair away from moving machinery.

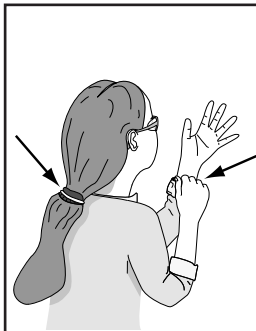

NOTICE

If you have never used this type of machine or equipment before, WE STRONGLY RECOMMEND that you read books, trade magazines, or get formal training before beginning any projects. Regardless of the content in this section, Grizzly Industrial will not be held liable for accidents caused by lack of training.



Operation Tips

Your safety is important. The tips below are intended to supplement **SECTION 1: SAFETY**. But remember, no safety list can be comprehensive of every situation. The operator is ultimately responsible for their own safety, as well as the safety of bystanders. Every cutting operation is uniquely different and may require safety equipment or safety procedures not mentioned in this manual.

Please follow these tips EVERY time you use your saw:

- Stand to the left of the blade line-of-cut when performing a cutting operation.
- Turn **OFF** the saw and allow the blade to come to a complete stop before removing the cut-off piece.
- Make sure that the riving knife is always aligned with the main blade before cutting!
- Always position the blade guard to the correct height above the workpiece.
- Carefully plan each cutting operation to avoid injuries.
- When you release the sliding table lock, make sure that the knob is positioned so that it will not lock the table during a cut.



Changing Blades

The Model G0588/G0591 will perform best when high quality, sharp blades are used. Therefore, whenever the blades start to get dull, we recommend that you have them resharpened or replaced with a new blade.

To change the blades:

1. **Disconnect the saw from the power source!**
2. Move the blade tilt to 0° (blade 90° to table) and raise the main blade as high as it will go.
3. Slide the table all the way forward to access the blade arbor, loosen the cap screw securing the lower blade guard, slide the cap screw up, and pull open the lower blade guard shown in **Figure 48**.

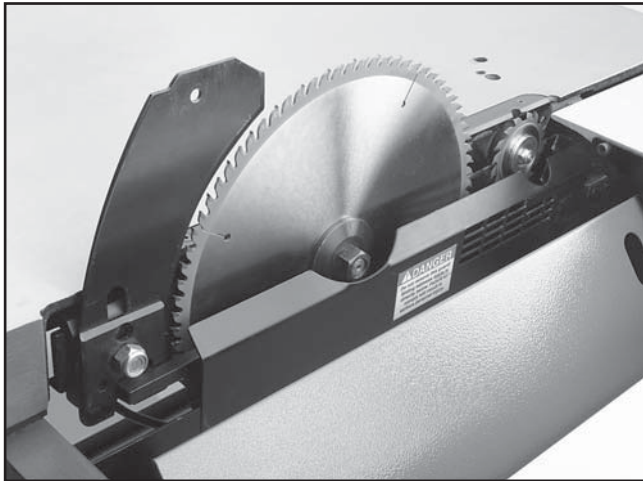

Figure 48. Internal blade guard exposed.

4. Place a hex wrench in the hole in the arbor of the blade you wish to change to prevent the arbor from rotating, then use the arbor wrench to remove the arbor nut and flange.

Note: The arbor nut on the main blade has left hand threads and loosens by turning clockwise. The arbor nut on the scoring blade has right hand threads and loosens by turning counterclockwise.

5. When replacing the scoring blade, measure the main blade and stack the scoring blade with shims to match the thickness of the main blade.
6. Install the main blade with the teeth facing the front of the saw, and install the scoring blade with the teeth facing back.
7. Re-install the arbor flange and the arbor nut and tighten them against the blade as shown in **Figure 49**.

Note: Wear gloves to protect your hands when installing or removing blades.

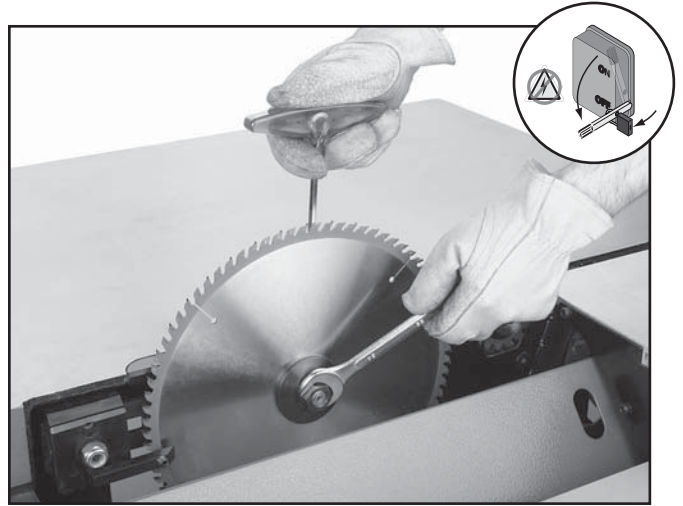

Figure 49. Replacing the main blade.

8. Position the riving knife about 3mm or 1/8" away from the nearest carbide tooth on the main blade.

Note: For a quick gauge, use the 3mm hex wrench to find the correct spacing between the blade and the riving knife.

9. Align the scoring blade set to the main blade as described in the **Aligning Blade and Riving Knife Alignment** instructions on **Page 27**.
10. Align the riving knife with the blades as instructed on **Page 27**.
11. Move the lower blade guard back into its original position and lock it in place with the cap screw.



Rip Cutting

The Model G0588/G0591 easily rips full size panels (**Figure 50**). The sliding table removes the burden of sliding a large and heavy panel over a stationary table surface.

This saw also can rip cut smaller boards using the machine as a traditional table saw (**Figure 51**). Smaller, lighter boards are easier to slide across the stationary cast iron table surface to the right of the saw blade.



Figure 50. Rip cutting with the sliding table.



Figure 51. Traditional rip cutting.

Rip cutting with the sliding table:

1. Install the crosscut fence, align the fence to 90°, and adjust it as instructed on **Page 48**.

2. Slide the protection block on the end of the crosscut fence against the blade teeth to calibrate the scale, then tighten the lock knob.

Note: *The scale will not be accurate if the protection block has been cut.*

3. Set a flip stop to the desired width-of-cut.
4. Position the blade guard to the correct height for your workpiece.
5. Load the workpiece onto the table saw. The set up should look similar to **Figure 50**.
6. When ripping irregular shaped stock, wedge the leading edge under the edge shoe (**Figure 52**), slide the hold down into place as shown in **Figure 52**, and clamp the stock firmly.

Note: *DO NOT use the edge shoe for ripping warped or twisted boards. The tension that causes warps and twists can cause the board to spring free from the edge shoe and hold down during a cut.*



Figure 52. Edge shoe and hold down placement.

6. Take all the necessary safety precautions, then perform the cutting operation.

Rip cutting using traditional table saw techniques:

1. Remove the crosscut fence.
2. Use the table lock (Figure 53) to lock the sliding table into a stationary position.



Figure 53. Sliding table lock.

3. Place the rip fence in the vertical position for larger workpieces or in the horizontal position for angled cuts and for thin workpieces (see Figure 54).



Figure 54. Rip fence positions.

4. Lift the lock lever and position the rip fence to approximately the desired width-of-cut.

5. Slide the leading end of the rip fence so it is even with the center of the main saw blade as shown in Figure 55.

Note: This technique allows the finished cut-off piece to “fall” away from the blade when the cutting operation is complete; reducing the possibility of kickback.

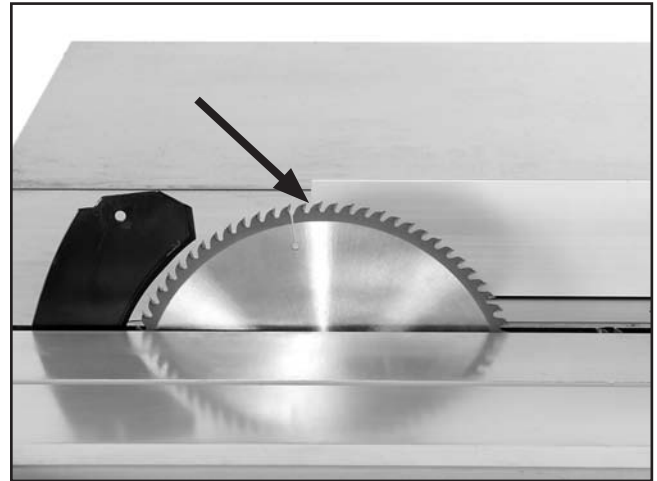

Figure 55. Rip fence even with center of blade (blade guard removed for clarity).

6. Push down on the rip fence micro-adjust knob (Figure 56) and turn it to adjust the width-of-cut.

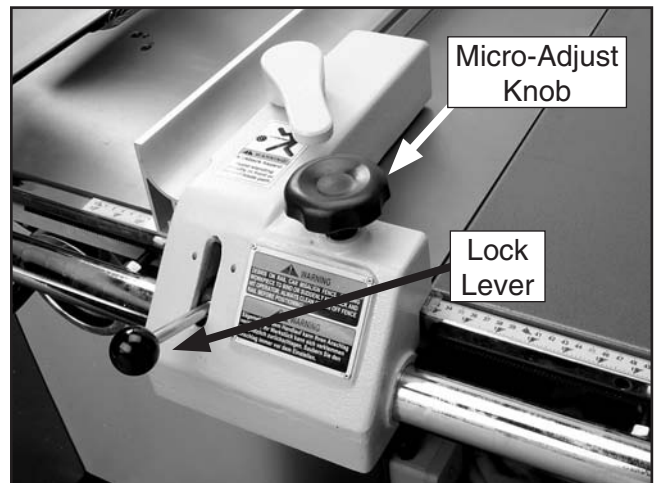

Figure 56. Rip fence micro-adjusting controls.

7. Push down the lock lever, then perform the cutting operation.



Crosscutting

The Model G0588/G0591 can crosscut full size panels with the fence in the forward or rear position, although it is easier to load full size panels with the crosscut fence mounted in the forward position (see **Figure 57**).

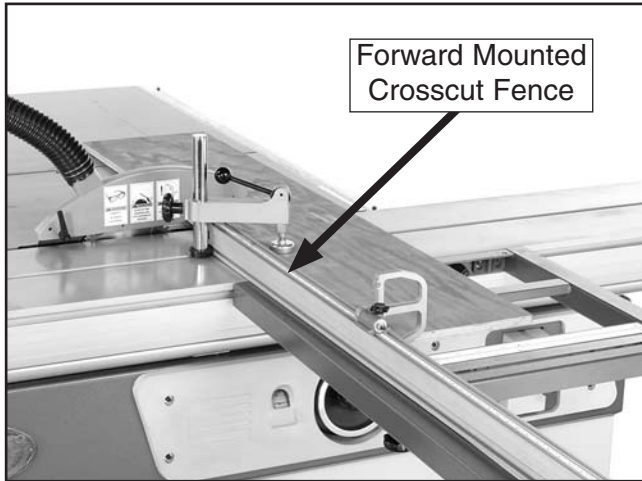

Figure 57. Crosscutting full size panel.

Mounting the crosscut fence in the rear position (**Figure 58**) gives greater stability for crosscutting smaller panels.

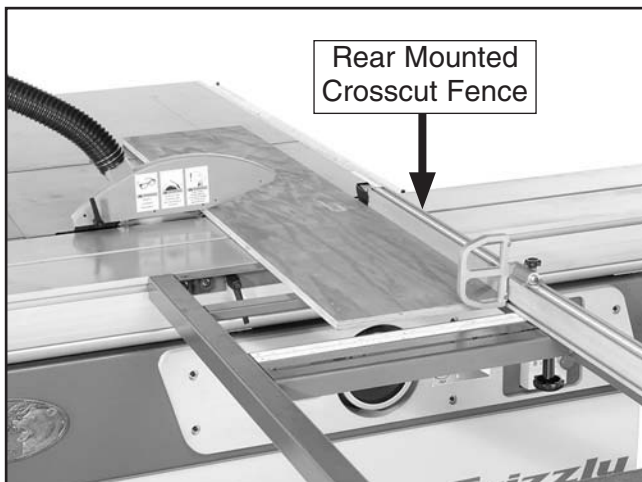

Figure 58. Crosscutting smaller panels.

Lastly, this machine has the capability of crosscutting workpieces while using the rip fence as a cut-off gauge (**Figure 59**).



Figure 59. Crosscutting workpieces using the rip fence as a cut-off gauge.

Determine which cutting operation will be best suited for the workpiece to be crosscut.

- If you will be crosscutting full size panels, then skip ahead to “Crosscutting full size panels.”
- If you will be crosscutting smaller panels, then skip ahead to “Crosscutting smaller panels.”
- If you will be crosscutting workpieces using the rip fence as a cut-off gauge, then skip ahead to “Crosscutting using the rip fence as a cut-off gauge.”

Crosscutting full size panels:

1. Install the crosscut fence in the forward mounting points shown in **Figure 60** and lock it in place.

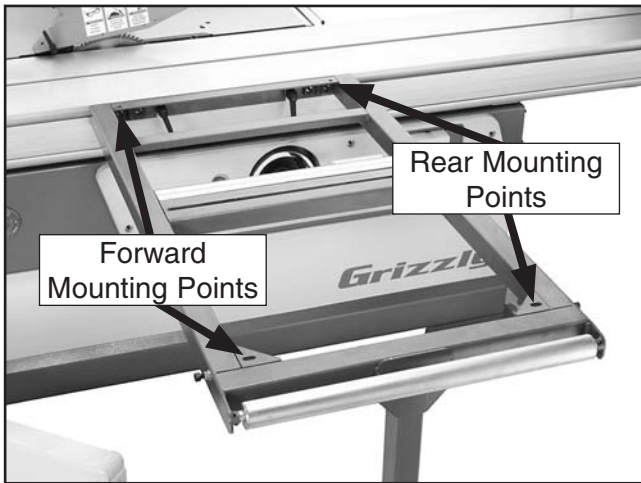

Figure 60. Crosscut fence mounting points.

2. Check to make sure the fence is at 90° and adjust it as described in **Squaring Crosscut Fence to Blade** on **Page 48** if necessary.
3. Set either flip stop to the desired width-of-cut.
4. Load the workpiece onto the table saw. The set up should look similar to **Figure 57**.
5. Once all the necessary safety precautions have been taken, perform the cutting operation.

Crosscutting smaller panels:

1. Install the crosscut fence in the rear mounting points shown in **Figure 60** and lock it in place.
2. Check to make sure the fence is at 90° and adjust it as described in **Squaring Crosscut Fence to Blade** on **Page 48** if necessary.
3. Set either flip stop to the desired width-of-cut.

4. Load the workpiece onto the table saw. The set up should look similar to **Figure 58**.
5. Once all the necessary safety precautions have been taken, perform the cutting operation.

Crosscutting using the rip fence as a cut-off gauge:

1. Install the crosscut fence in the rear mounting points shown in **Figure 60** and lock it in place.
2. Check to make sure the fence is at 90° and adjust it as described in **Squaring Crosscut Fence to Blade** on **Page 48** if necessary.
3. Position the rip fence for the desired width.
4. Load the workpiece onto the table saw. The set up should look similar to **Figure 59**.
5. Slide the leading end of the rip fence behind the back edge of the blade as shown in **Figure 61**.



Figure 61. Correct rip fence position when using it as a cut-off gauge.

6. Take all the necessary safety precautions, then perform the cutting operation.



Miter Cutting

The miter fence allows miter cuts from 0° through 135°. The table mounted miter scale has a resolution of 1°.

To perform a miter cut:

1. Slide the crosscut table to the front edge of the sliding table and lock it in place.
2. Install the fence as shown in **Figure 62** for 90° to 135° cuts, or as shown in **Figure 64** for 0° to 90° cuts.



Figure 62. Fence set-up for 90° to 135° cuts.

3. Set the fence to the desired angle using the crosscut table angle gauge and lock the angle with the lock knob (see **Figure 63**).

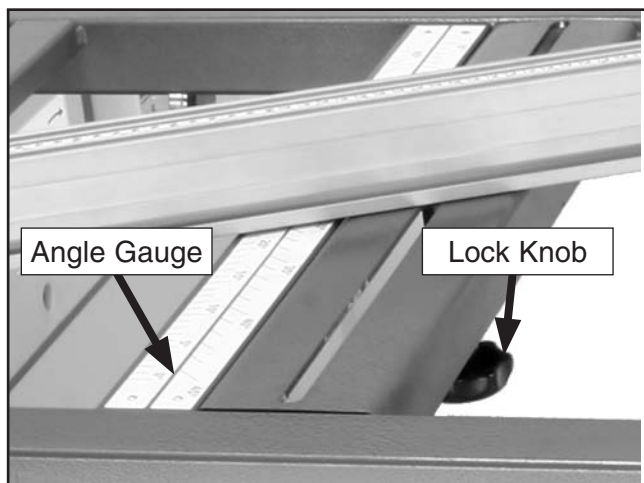

Figure 63. Crosscut table angle gauge.

4. Position the flip stop according to the length of the workpiece you want to cut off to the left of the blade.
5. Load the workpiece onto the table saw. The set up should look similar to **Figure 64**.



Figure 64. Example of miter cutting operation.

6. Once all the necessary safety precautions have been taken, perform the cutting operation.



SECTION 5: ACCESSORIES

G7895—Citrus Degreaser

This citrus based degreaser is perfect for cleaning cosmoline off of new equipment. It also works for cleaning auto parts, tools, concrete, and porcelain surfaces. Natural, safe for the environment, and contains no CFC's.



Figure 65. G7895 Citrus Degreaser.

G1955—OxiSolv® Blade & Bit Cleaner

Used to clean the gummy pitch and residue from saw blades and router bits, this high quality cleaner will make blades and bits last longer while improving cutting action.



Figure 66. G1955 OxiSolv®.

G5562—SLIPIT® 1 Qt. Gel

G5563—SLIPIT® 12 oz Spray

Used on cast iron table surfaces and other unpainted metal surfaces to reduce sliding friction and hangups. This product also reduces rust and prevents resin build-up.



Figure 67. G5562 & G5563 SLIPIT.

G2871—Boeshield® T-9 12 oz Spray

G2870—Boeshield® T-9 4 oz Spray

This ozone friendly protective spray penetrates deep and really holds up against corrosive environments. Lubricates metals for months and is safe for use on most paints, plastics, and vinyls.



Figure 68. Boeshield® T-9 spray.

Call 1-800-523-4777 To Order

- G7984—Face Shield**
- H1298—Dust Sealed Safety Glasses**
- H1300—UV Blocking, Clear Safety Glasses**
- H2347—Uvex® Spitfire Safety Glasses**
- H0736—Shop Fox® Safety Glasses**

Safety Glasses are essential to every shop. If you already have a pair, buy extras for visitors or employees. You can't be too careful when it comes to shop safety!



Figure 69. Our most popular safety glasses.

- H2499—Small Half-Mask Respirator**
- H3631—Medium Half-Mask Respirator**
- H3632—Large Half-Mask Respirator**
- H3635—Disposable Cartridge Filter Pair P100**

Wood dust is now considered a known carcinogen and has been linked to nasal cancer and severe respiratory illnesses. If you work around dust everyday, a half-mask respirator can be a lifesaver. Also compatible with safety glasses!



Figure 70. Half-mask respirator and disposable cartridge filters.

- Carbide-Tipped Saw Blades (ATB)**
- G4808—12" Ripping, 40T**
- G4809—12" General Purpose, 60T**
- G4810—12" Fine Finishing/Cabinet Work, 80T**

These ATB blades are manufactured to close tolerances and are fully balanced before leaving the factory. All the carbide-tipped teeth are precisely ground to give a smooth cut every time. The pattern of the teeth is alternate top bevel and the saw kerf is approx. 1/8". These blades have proven themselves in thousands of cabinet shops around the country. Manufactured for heavy-duty use.



Figure 71. Carbide-tipped saw blades.

- H6460—12 Tooth Scoring Blade Set**

The scoring blade set consists of an inner and outer blade and four internal shims. Two shims are 0.008" thick and two are 0.004". The shims are provided so the scoring blade set can match the kerf thickness of the main blade.

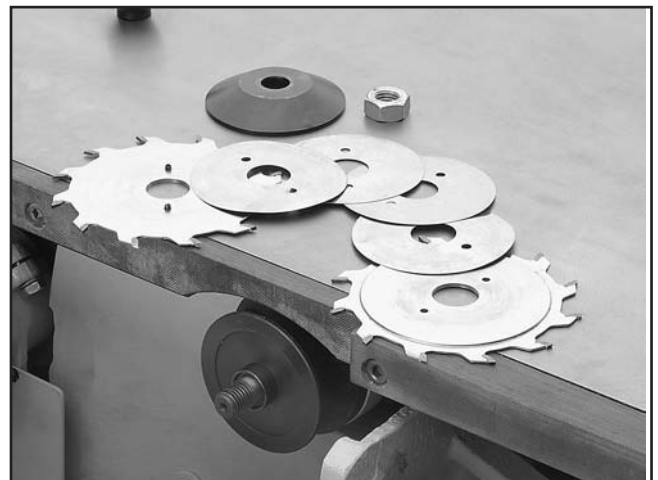

Figure 72. H6460 Scoring Blade Set.

H3308—SHOP FOX® Push Stick

Measuring 13½" overall, this push stick allows the operator to keep their hands at a safe distance away from the blade or cutter.



Figure 73. H3308 SHOP FOX® Push Stick.

G3445—Precision Saw Tool

This high impact plastic Saw Aid™ quickly measures blade height and angle and can also serve as a solid push stick. Includes a graduated ruler guide and center finder.

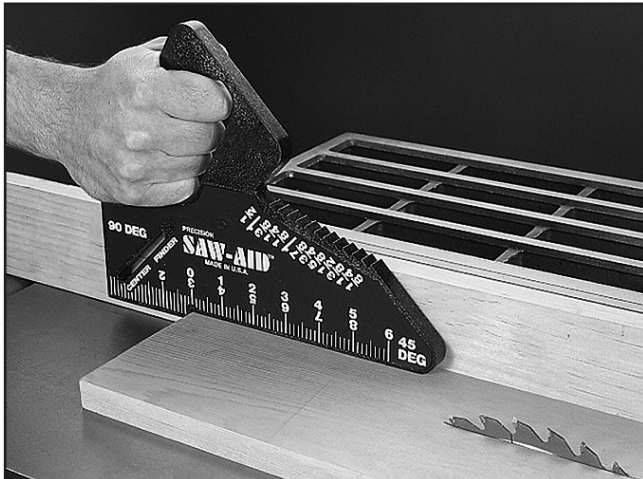

Figure 74. G3445 Precision Saw Tool.

H3771—Blade Loc®

This simple tool secures the blade during blade changes, keeping your hands safe and your expensive blade from being damaged.



Figure 75. H3771 Blade Loc®.

G7581—Superbar™

G7582—Master Plate

The miter slot mounted Superbar™ will align, tune and calibrate your tablesaw to within ±0.001 in just minutes. Replace your tablesaw blade when calibrating the double disk ground Master Plate for a precision measurement, with no runout!

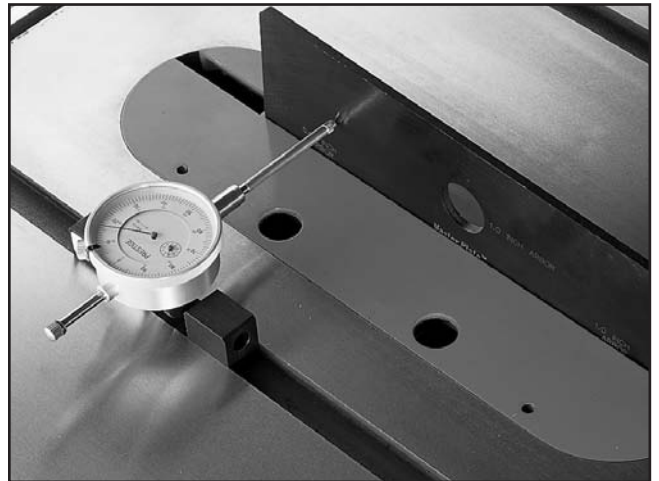
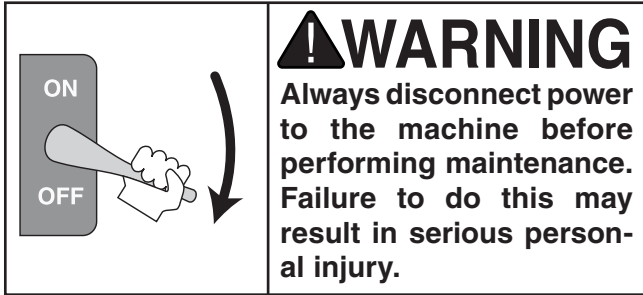

Figure 76. Superbar™ and Master Plate.

Call 1-800-523-4777 To Order



SECTION 6: MAINTENANCE



Schedule

For optimum performance from your machine, follow this maintenance schedule and refer to any specific instructions given in this section.

Daily Check:

- Loose mounting bolts.
- Worn or damaged saw blade.
- Worn or damaged switches or wires.
- Any other unsafe condition.

Weekly Maintenance:

- Clean sliding table surface and grooves.
- Clean the cast iron saw table.
- Clean the sliding table roller guideways.
- Clean the rip fence and sliding grooves.
- Clean the rip fence bracket.

Monthly Check:

- Clean/vacuum dust buildup from inside cabinet and off motor.
- V-belt tension, damage, or wear.

Note: *Adjust V-belt tension after the initial 10 hours of operation.*



Cleaning

Cleaning the Model G0588/G0591 is relatively easy. Vacuum excess wood chips and sawdust, and wipe off the remaining dust with a dry cloth. Use compressed air to blow dust from between the two sections of the sliding table. If any resin has built up, use a resin dissolving cleaner to remove it. Treat all unpainted cast iron and steel with a non-staining lubricant after cleaning.



Unpainted Cast Iron

Protect the unpainted cast iron surfaces on the table by wiping the table clean after every use—this ensures moisture from wood dust does not remain on bare metal surfaces.

Keep tables rust-free with regular applications of products like G96® Gun Treatment, SLIPIT®, or Boeshield® T-9 (see **SECTION 5: ACCESSORIES** on **Page 40** for more details).



Lubrication

The bearings are sealed and pre-lubricated and require no lubrication during their usable life. However, your saw components will operate at their best if the bearing surfaces are kept clean—this is especially important for the trunnion bearings.

Lubricate the areas indicated below every 6-12 months, depending on frequency of use.

1. **Blade angling pivots.** These should be lubricated with 6 or 7 drops of light machine oil (see **Figure 77**).

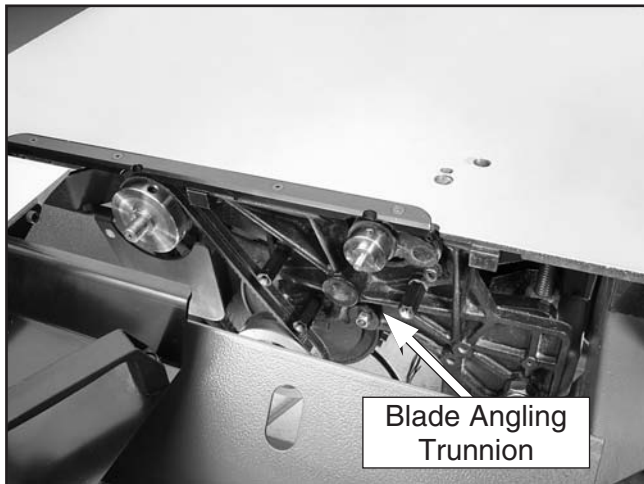

Figure 77. Blade angling trunnions.

2. **Sliding table ways.** Spray or wipe on a light machine oil or lubricant such as Boeshield T9® the entire length of the steel rods (see **Figure 78**).



Figure 78. Sliding table ways.

3. **Blade height worm gears.** Lubricate with an automotive wheel bearing grease (see **Figure 79**).

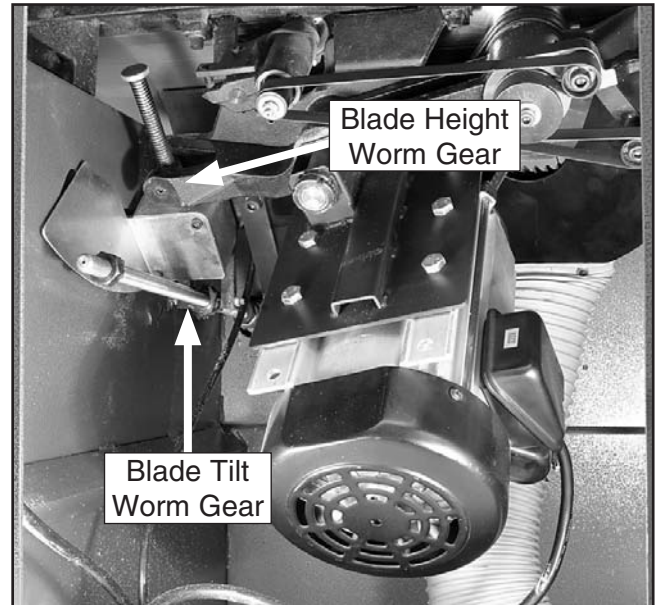
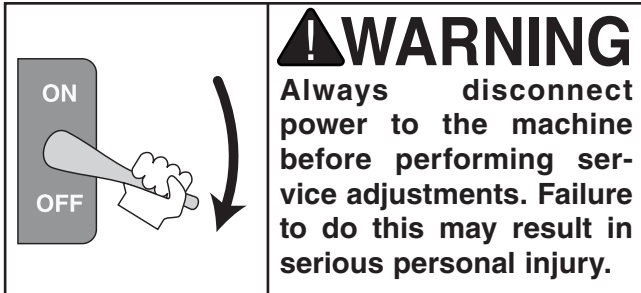

Figure 79. Gear lubrication.

4. **Blade tilt worm gear.** Lubricate with an automotive wheel bearing grease.



SECTION 7: SERVICE



About Service

This section is designed to help the operator with adjustments that were made at the factory and that might also need to be made during the life of the machine.

This section is provided for your convenience—it is not a substitute for the Grizzly Service Department. If any adjustments arise that are not described in this manual, then feel free to call the Grizzly Service Department at (570) 546-9663.

Similarly, if you are unsure of how to perform any procedure in this section, the Grizzly Service Department will be happy to guide you through the procedures or help in any other way.



Replacing Belts

To ensure optimum power transmission from the motor to the blades, the belts must be in good condition (free from cracks, fraying and wear) and operate under proper tension.

To change the main blade arbor V-belt:

1. Disconnect the saw from the power source!
2. Move the blade tilt to 45°, lower the main blade all the way down, and open the motor cabinet door.
3. Loosen the belt tension bolt (**Figure 80**) and pivot the motor up.

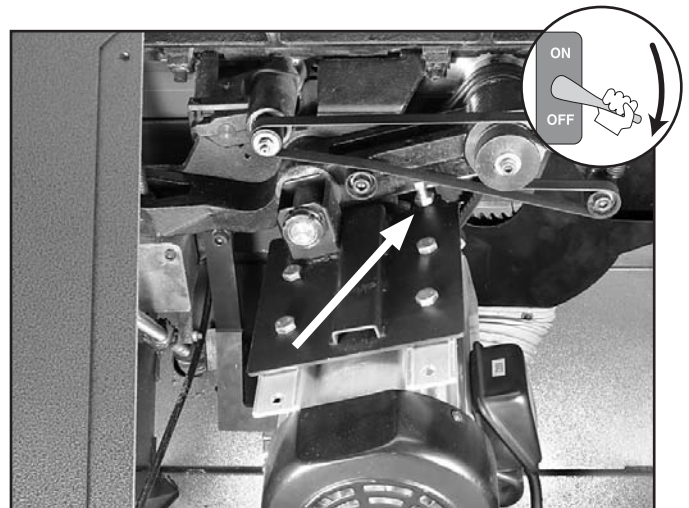

Figure 80. V-belt tension bolt.

4. Remove the screws that secure the lower blade guard (**Figure 81**) and set the guard in the bottom of the cabinet.

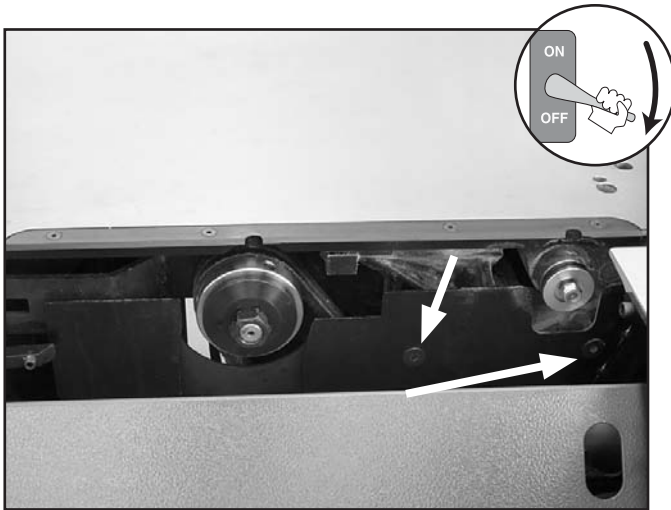

Figure 81. Lower blade guard removal.

5. Remove the old V-belt set and replace them with a new V-belt set.

Note: *The motor V-belts should always be replaced as a matched set to ensure maximum belt longevity and power transmission.*

6. Tighten the tension bolt until the belts deflect between a ¼" and a ½" when pressed firmly in the center of each V-belt.
7. Replace the lower blade guard.
8. Close and secure the motor cabinet door.

Note: *Re-tension the new V-belts after the initial 10 hours of use.*

To change the scoring blade arbor flat belt:

1. **Disconnect the saw from the power source!**
2. Move the blade tilt to 45°, raise the main blade all the way up, and open the motor cabinet door.

3. Rotate the belt tension arm shown in **Figure 82** and slide the flat belt off of the roller.

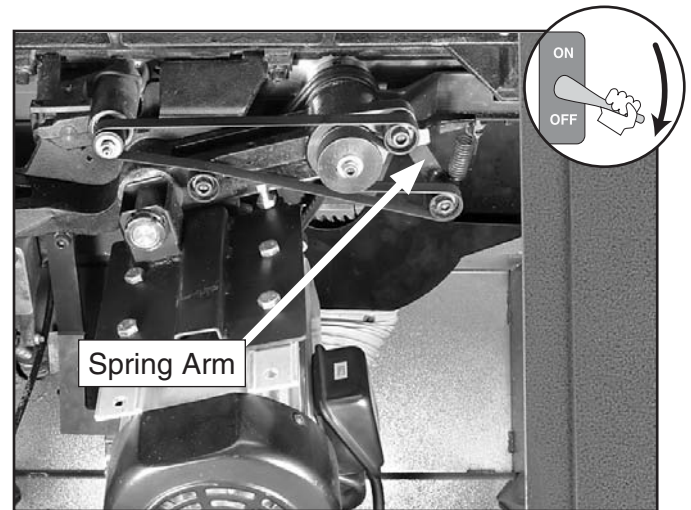

Figure 82. Scoring blade belt tension arm.

4. Remove the old flat belt and replace it with a new flat belt.
5. Close and secure the motor cabinet door.



Blade Tilt

The blade tilt is calibrated at the factory, but can be adjusted if it changes during the life of the machine.

To calibrate the blade tilt:

1. **Disconnect the saw from the power source!**
2. Move the blade tilt to 90° according to the gauge, and raise the main blade as high as it will go.
3. Place a machinist's square on the table surface and between the blade teeth. Inspect for gaps between the blade and the square.
4. If a gap exists at either the top or bottom of the square, loosen the set screw in the 90° tilt stop nut shown in **Figure 83**.

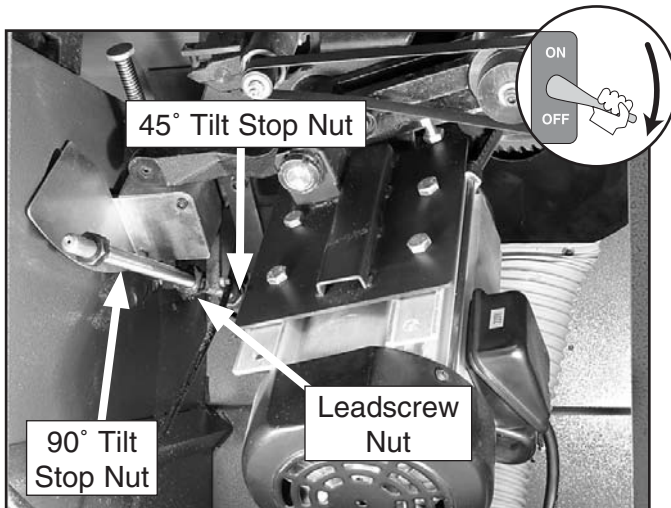

Figure 83. Blade tilt stop nuts.

5. Turn the handwheel until the blade and square are flush from top to bottom.
6. Snug the 90° tilt stop nut against the leadscrew nut and tighten the set screw.
7. Recheck the blade with the square to ensure the nut has not been over-tightened.

8. Adjust the blade angle until you hit the 45° positive stop. Check the bevel with an adjustable square set to 45°.
9. If variations exist, loosen the set screw in the 45° tilt stop nut (**Figure 83**) and adjust the stop nut until the blade and square match.
10. Tighten the set screw and recheck the bevel by adjusting the blade back to 90°, then back to 45°.
11. Check the scale for accuracy at 45° and 90°.
 - If the scale reads 45° when the blade is at 45° and 0° when the blade is at 90° to the table, it is accurate.
 - If the scale reading does not match the blade angle, perform the adjustments in **Step 12**.
12. Loosen the lock nut called out in **Figure 84** and rotate the barrel nut until the scale matches the blade angle.

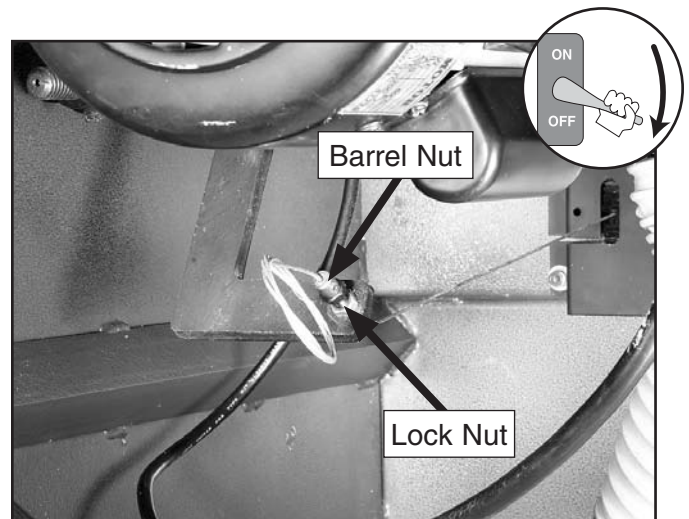

Figure 84. Scale adjustment nuts.

13. Tighten the lock nut and recheck the scale at 90° and 45°.



Squaring Crosscut Fence to Blade

Squaring the crosscut fence to the blade ensures that cuts made with the crosscut fence will be square. This procedure can be done by using a piece of scrap plywood as a test piece and making five test cuts, then adjusting the fence as necessary.

To square the crosscut fence with the blade:

1. Make sure the blade is parallel with the sliding table.
2. Prepare the scrap test piece by numbering all four sides as shown in **Figure 85**.

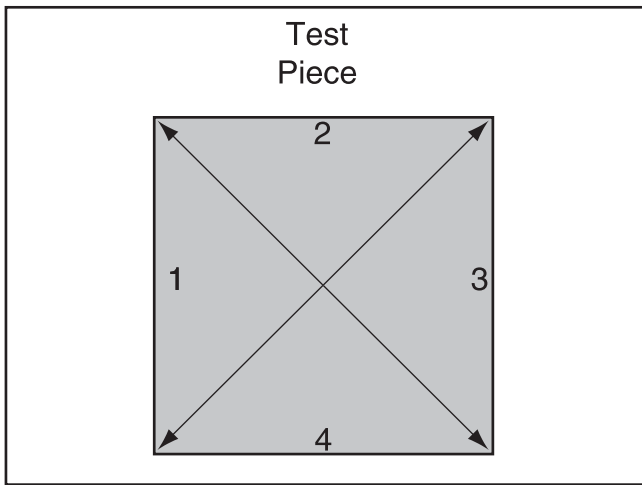

Figure 85. Fence adjustment test piece.

3. Use the crosscut fence to cut $\frac{1}{2}$ " off of each side of the test piece, then cut side 1 again (make 5 cuts total).
4. Measure the test piece diagonally from corner-to-corner as shown in **Figure 85**.
—If both measurements are not within $\frac{1}{16}$ ", then the crosscut fence needs to be adjusted. Proceed to **Step 6**.
— If both measurements are within $\frac{1}{16}$ " then you are finished with this procedure.
5. Loosen the hex nut shown in **Figure 86** and rotate the hex bolt to square the crosscut fence.

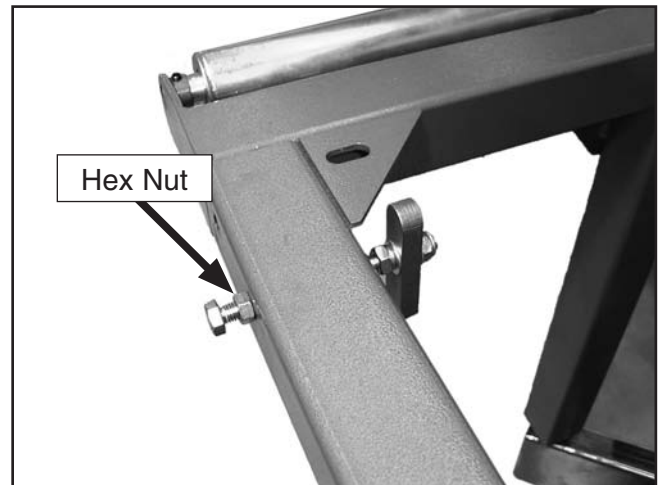

Figure 86. Crosscut fence adjustment cam.

6. Tighten the hex nut and repeat **Steps 3-6**.



Electrical

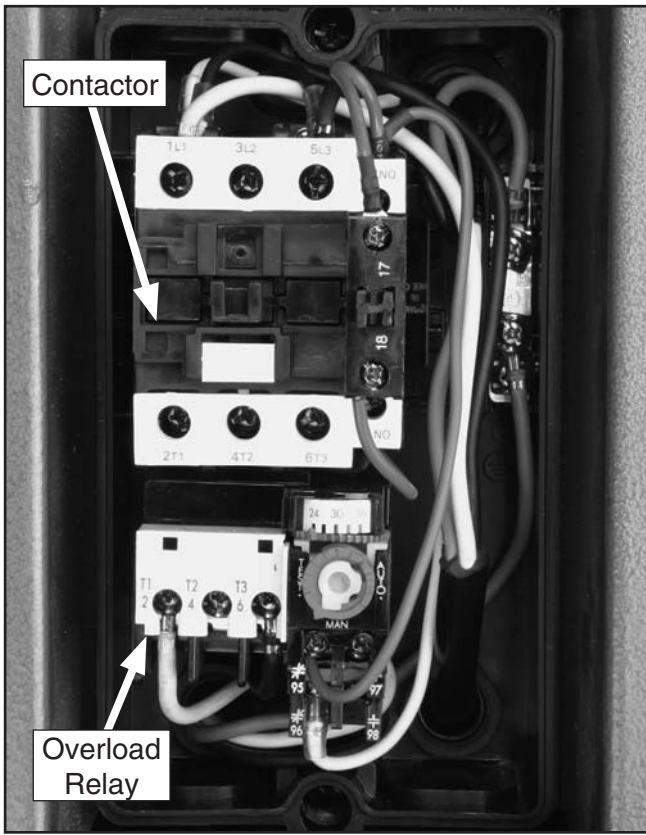

Figure 87. G0591 single phase magnetic switch.

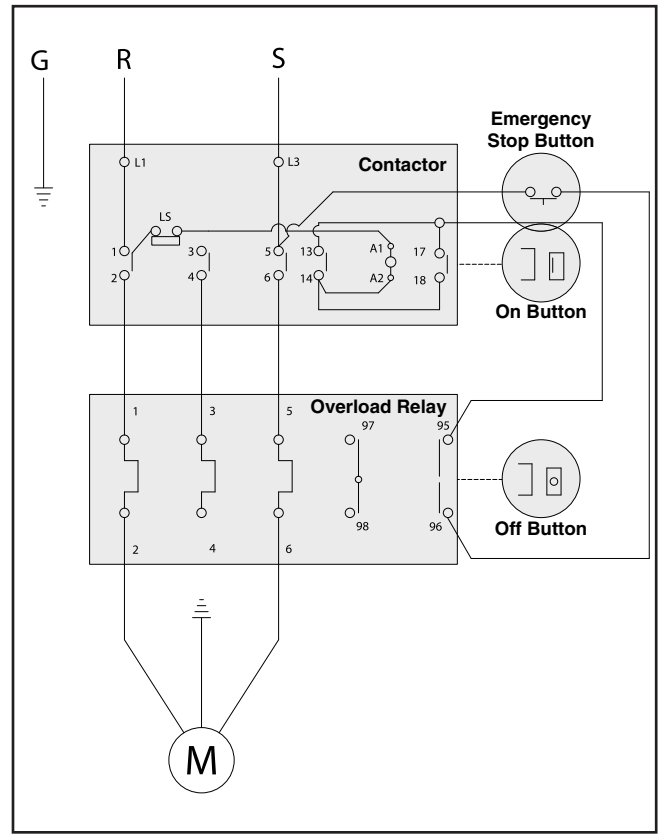

Figure 89. G0591 single phase wiring diagram.

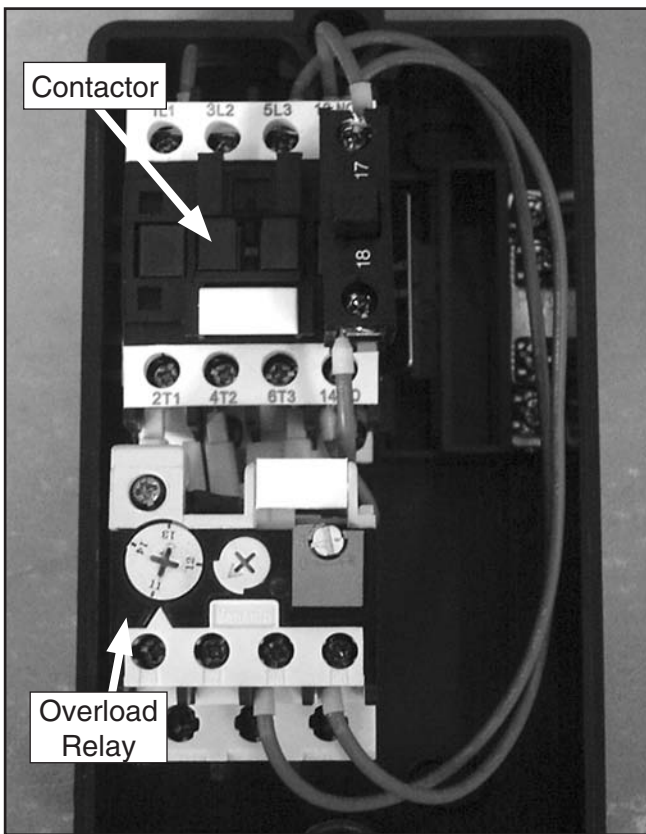

Figure 88. G0588 3-phase magnetic switch.

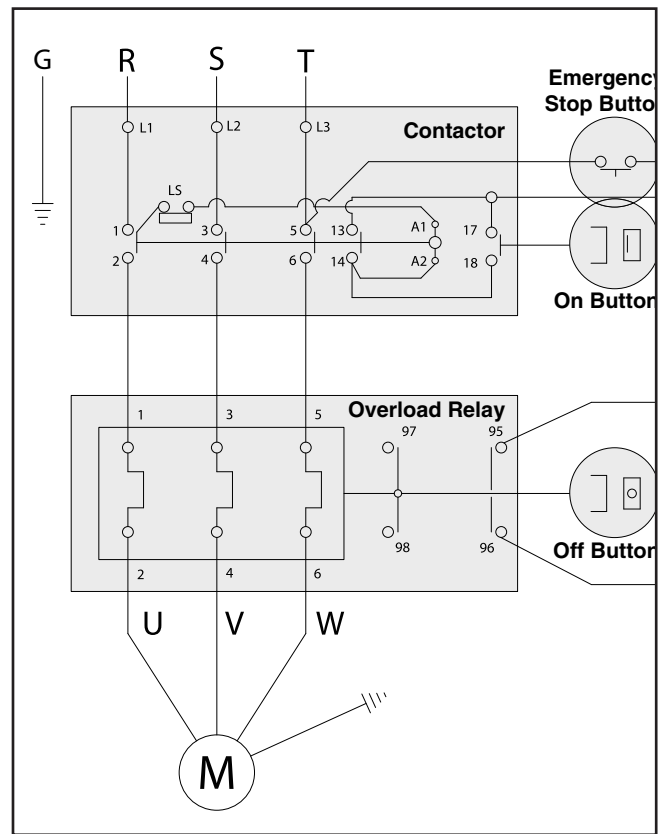
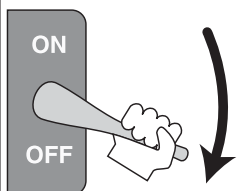

Figure 90. G0588 3-phase wiring diagram.

Troubleshooting

Symptom	Possible Cause	Possible Solution
Motor will not start, or it growls on start up.	<ol style="list-style-type: none"> Emergency stop button is depressed. Power supply fuse or circuit breaker has tripped. Thermal overload has tripped. Toggle switch is broken inside. Start capacitor is at fault. Motor fan cover is dented, stopping the fan from being able to spin. Motor is at fault. 	<ol style="list-style-type: none"> Rotate the button clockwise and allow it to pop out. Disconnect power, and inspect circuit for electrical shorts and repair. Replace circuit breaker if it is old or has tripped many times. Reset the thermal overload. Disconnect power, and use an ohmmeter to check switch terminals for continuity, and replace switch if required. Replace start capacitor. Replace motor fan cover (and fan, if damaged). Replace motor.
Motor fails to develop full power (output of motor decreases rapidly with decrease in voltage at motor terminals).	<ol style="list-style-type: none"> Power line overloaded with lights, appliances, and other motors. Undersized wires or circuits too long. Blown capacitor. 	<ol style="list-style-type: none"> Reduce load on power line. Increase wire sizes or reduce length of the circuit. Replace the capacitor.
Motor overheats.	<ol style="list-style-type: none"> Motor overloaded. Air circulation through the motor restricted. 	<ol style="list-style-type: none"> Reduce load on motor. Clean out motor to provide normal air circulation.
Motor stalls (resulting in blown fuses or tripped circuit).	<ol style="list-style-type: none"> Short circuit in motor or loose connections. Low voltage. Incorrect fuses or circuit breakers in power line. Motor overloaded. 	<ol style="list-style-type: none"> Repair loose or shorted terminals, or worn insulation on motor. Correct the low voltage conditions. Install correct fuses or circuit breakers. Reduce load on motor.
Main blade runs backwards (Model G0588 only).	<ol style="list-style-type: none"> Two of the power wires are reversed. 	<ol style="list-style-type: none"> Exchange wires R & T in the terminal box.
Blade slows when cutting. Blade makes a squealing noise on start-up.	<ol style="list-style-type: none"> V-belt loose. V-belt worn out. 	<ol style="list-style-type: none"> Tighten V-belt (Page 45). Replace V-belt (Page 45).



!WARNING

Disconnect power to the machine when performing any troubleshooting. Failure to do this may result in serious personal injury.

Symptom	Possible Cause	Possible Solution
Loud repetitious noise coming from machine.	<ol style="list-style-type: none"> 1. Pulley setscrews or keys are missing or loose. 2. Motor fan is hitting the cover. 3. V-belts are defective or damaged. 	<ol style="list-style-type: none"> 1. Inspect keys and setscrews. Replace or tighten if necessary. 2. Adjust fan cover mounting position, tighten fan, or shim fan cover. 3. Replace V-belts (Page 45).
Vibration when running or cutting.	<ol style="list-style-type: none"> 1. Loose or damaged blade. 2. Worn arbor bearings. 3. Worn or damaged belts. 	<ol style="list-style-type: none"> 1. Tighten or replace blade. 2. Check/replace arbor bearings. 3. Replace belts.
Workpiece has burned edges, binds, or kicks back.	<ol style="list-style-type: none"> 1. Sliding table is not parallel to blade. 2. Riving knife is not aligned with the blade. 3. Blade is warped. 	<ol style="list-style-type: none"> 1. Make sliding table parallel to the blade (Page 29). 2. Shim the riving knife to align it with the main blade. 3. Replace the blade.
Workpiece has chip out on the bottom edge.	<ol style="list-style-type: none"> 1. Scoring blade height is incorrect. 2. Scoring blade is not aligned with the main blade. 3. Scoring blade kerf does not match the main blade. 	<ol style="list-style-type: none"> 1. Adjust the height of the scoring blade to 2mm or $\frac{5}{64}$". 2. Align the scoring blade (Page 27). 3. Adjust the scoring blade kerf (Page 26).
Sliding table saw does not cut square.	<ol style="list-style-type: none"> 1. Sliding table is not parallel to blade. 2. Rip fence is not parallel to blade. 3. Crosscut fence is not perpendicular to the blade. 	<ol style="list-style-type: none"> 1. Adjust the sliding table (Page 29). 2. Adjust the rip fence (Page 23). 3. Adjust the crosscut fence perpendicular to the blade (Page 48).
Fence hits table top when sliding across table.	<ol style="list-style-type: none"> 1. Front rail is too low. 2. Rip fence roller is too low. 	<ol style="list-style-type: none"> 1. Raise the rail (Page 23). 2. Adjust the roller (Page 23).
Blade does not reach 90°, or blade does not reach 45°.	<ol style="list-style-type: none"> 1. Blade stop nuts are out of adjustment. 	<ol style="list-style-type: none"> 1. Adjust the stop nuts (Page 47).
The rip fence scale is not accurate.	<ol style="list-style-type: none"> 1. The rip fence scale is out of calibration or was not set up correctly. 	<ol style="list-style-type: none"> 1. Adjust the rip fence scale (Page 31).
Tilt or blade height handwheels difficult to turn.	<ol style="list-style-type: none"> 1. Lock knob is tight. 2. Gears caked with dust. 	<ol style="list-style-type: none"> 1. Release the lock knob. 2. Clean out dust and grease the worm shafts.

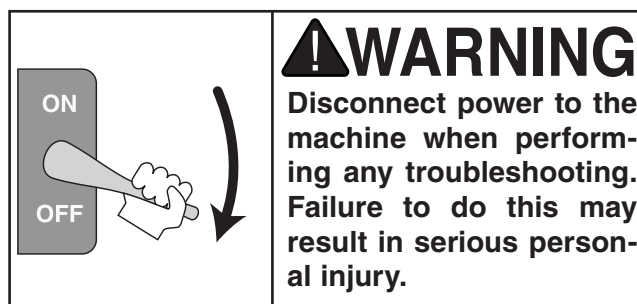

SECTION 8: PARTS

Main Body

REF	PART #	DESCRIPTION
1	P0588001	BODY
2	P0588002	TABLE
3	PW01M	FLAT WASHER 8MM
4	PSB13M	CAP SCREW M8-1.25 X 30
5	P0588005	SWITCH PLATE
6	P0588006	SWITCH BASE
7	PS06M	PHLP HD SCR M5-.8 X 20
8	P0588008	MAG. SWITCH 220V-25A
9	PSB01M	CAP SCREW M6-1 X 16
10	P0588010	COVER PLATE
11	P0588011	SCALE PLATE
12	PSB02M	CAP SCREW M6-1 X 20
13	P0588013	ADJUSTMENT BOLT COVER
14	PSB26M	CAP SCREW M6-1 X 12
15	P0588015	MOTOR COVER
16	PSB49M	CAP SCREW M6-1 X 60
78	PB137M	HEX BOLT M14-2 X 30
81	PN32M	HEX NUT M14-2
199	P05910199	MAG. SWITCH 440V-14A

REF	PART #	DESCRIPTION
199-1	P05910199-1	OVERLOAD RELAY
199-2	P05910199-2	MAGNETIC CONTACTOR
202	P0588202	DUST SHIELD
278	P0588278	SCALE DUST COVER
307	P0588307	TERMINAL BOX
308	P0588308	EMERGENCY BUTTON
309	PLABEL-12	READ MANUAL 2"W X 3 5/16"
310	P0588310	KICKBACK WARNING LABEL
311	P0588311	DISCONNECT POWER LABEL
312	PLABEL-11	SAFETY GLASSES 2" X 3 5/16"
313	PLABEL-29	CUTTERHEAD GUARD LABEL
314	P0588314	RAISING BLADE LABEL
315	P0588315	TILTING BLADE LABEL
316	P0588316	QUALIFIED PERSONNEL LABEL
317	PLABEL-34	PREWIRED 220V LABEL
318	P0588318	LOWER BLADE GUARD LABEL
319	PLABEL-14	ELECTRICITY LABEL
320	P0591320	G0591 ID LABEL
321	P0588320	G0588 ID LABEL

Extension Tables

REF	PART #	DESCRIPTION
3	PW01M	FLAT WASHER 8MM
9	PSB02M	CAP SCREW M6-1 X 20
17	P0588017	TABLE INSERT
18	PFH07M	FLAT HD SCR M5-.8 X 10
19	P0588019	EXTENSION WING (FRONT)
20	PSB13M	CAP SCREW M8-1.25 X 30
21	PSS16M	SET SCREW M8-1.25 X 10
23	P0588023	EXTENSION WING (RIGHT)
24	PB116M	HEX BOLT M10-1.5 X 45
25	PW04M	FLAT WASHER 10MM
26	P0588026	EXTENSION WING SUPPORT
27	PB138M	HEX BOLT M16-2 X 100
28	PN13M	HEX NUT M16-2

REF	PART #	DESCRIPTION
29	PN01M	HEX NUT M6-1
30	PW03M	FLAT WASHER 6MM
31	P0588031	SCALE BASE
32	P0588032	TUBE PLUG
33	P0588033	SCALE
36	P0588036	RACK
37	PSB03M	CAP SCREW M5-.8 X 8
38	P0588038	RAIL
39	P0588039	STUD M12-1.75 X 120
40	PN09M	HEX NUT M12-1.75
41	PW06M	FLAT WASHER 12MM
279	P0588279	FENCE RAIL PLUG 45 X 33

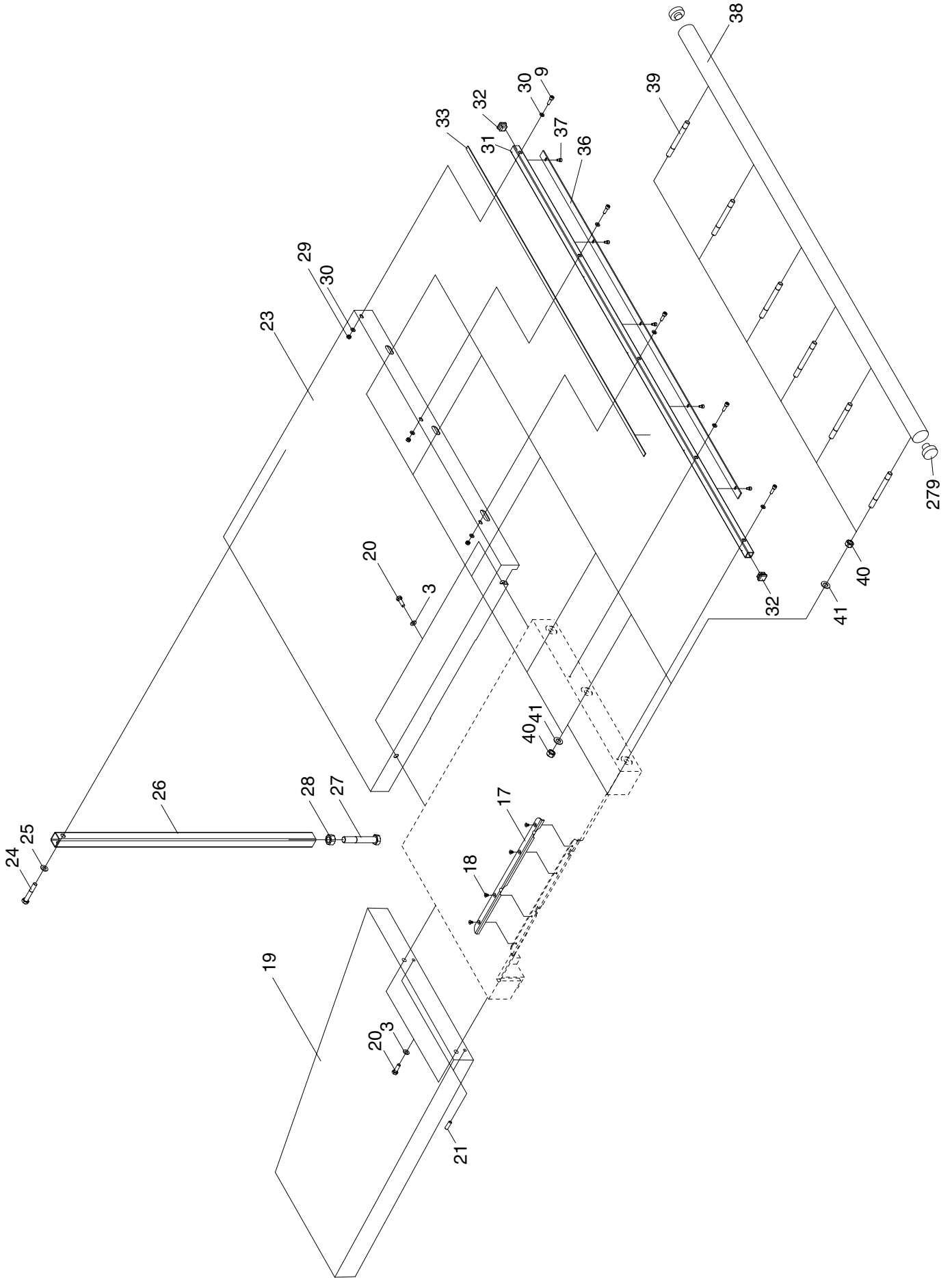

Sliding Table

REF	PART #	DESCRIPTION
9	PSB01M	CAP SCREW M6-1 X 16
42	P0588042	SLIDING TABLE
43	P0588043	SLIDING TABLE END
44	PSB01M	CAP SCREW M6-1 X 16
45	P0588045	RUBBER PLATE
46	PFH23M	FLAT HD SCR M8-1.25 X 16
47	P0588047	GIB
48	PB83M	HEX BOLT M6-1 X 16
49	P0588049	STEEL RAILS
50	P0588050	HANDLE
51	P0588051	HANDLE COVER
52	P0588052	STOP LEVER
53	P0588053	SLEEVE
54	P0588054	EXTENSION SPRING
55	PN13M	HEX NUT M16-2
56	P0588056	STOP PIN
57	P0588057	HOLD DOWN BRACKET
58	PR02M	EXT. RETAINING RING 14MM
59	PRP45M	ROLL PIN 5 X 32
60	P0588060	COMPRESSION SPRING
61	P0588061	CAM
62	P0588062	HANDLE SHAFT
63	P0588063	BALL HANDLE

REF	PART #	DESCRIPTION
64	P0588064	HOLD DOWN ARBOR
65	P0588065	PLASTIC HOLD DOWN WASHER
66	P0588066	T-NUT PLATE
67	P0588067	EDGE SHOE PLATE
68	P0588068	T-NUT PLATE
69	PB74M	HEX BOLT M10-1.5 X 20
70	P0588070	ADJUST HANDLE M10-1.5 X 16
71	P0588071	STEEL BALL BASE
72	P0588072	STEEL BALL BASE SPONGE
73	P0588073	STEEL BALL DIA. 18MM
74	P0588074	STEEL BALL DIA. 11/16MM
75	P0588075	SLIDING BASE
76	P0588076	SLIDING BASE COVER (BACK)
77	P0588077	SLIDING BASE COVER (FRONT)
78	PB137M	HEX BOLT M14-2 X 30
79	PB153M	HEX BOLT M14-2 X 40
80	P0588080	ADJUSTMENT PLATE
81	PN32M	HEX NUT M14-2
259	P0588259	HOLD DOWN PLATE
260	P0588260	KNOB M8-1.25 X 20
261	P0588261	HOLD DOWN SHAFT
302	PSB14M	CAP SCREW M8-1.25 X 20
304	P0588304	PUSH HANDLE M14-2 X 16

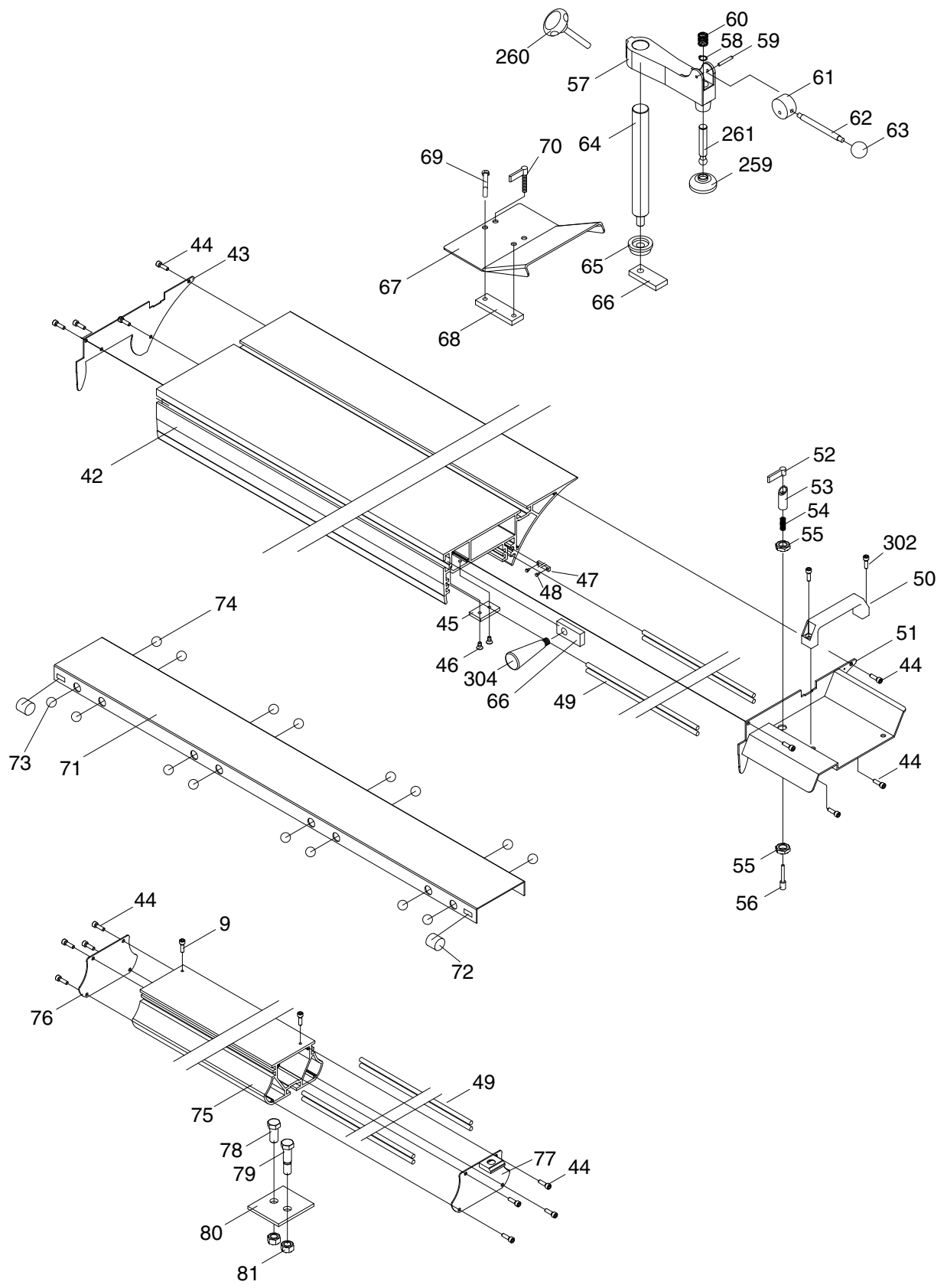

Crosscut Table

REF	PART #	DESCRIPTION
21	PSS16M	SET SCREW M8-1.25 X 10
22	PN03M	HEX NUT M8-1.25
25	PN02M	HEX NUT M10-1.5
29	PN01M	HEX NUT M6-1
37	PS05M	PHLP HD SCR M5-.8 X 8
44	PSB01M	CAP SCREW M6-1 X 16
82	P0588082	CROSSCUT TABLE
83	P0588083	CROSSCUT TABLE ROLLER
84	P0588084	SUPPORT ADJUSTMENT BLOCK
85	PSB04M	CAP SCREW M6-1 X 10
86	PSS09M	SET SCREW M8-1.25 X 20
87	P0588087	SCALE LABEL (RIGHT)
88	P0588088	SCALE LABEL (LEFT)
89	P0588089	SLIDING SURFACE PLATE
90	P0588090	CROSSCUT TABLE LOCK PLATE
92	P0588092	ADJUST HANDLE M10-1.5
93	P0588093	SWING ARM
94	P0588094	ROLLER
94A	P0588094A	ECCENTRIC ROLLER
95	P6900	BALL BEARING 6900
95A	P6901	BALL BEARING 6901

REF	PART #	DESCRIPTION
96	P0588096	ROTATE SHAFT
96A	P0588096A	ECCENTRIC SHAFT
97	P0588097	ROTATE ARBOR SUPPORT
98	P0588098	MAGNET
99	P0588099	MAGNET BASE
100	PFH30M	FLAT HD SCR M5-.8 X 8
101	P0588101	NYLON SCREW M12-1.75 X 12
102	P0588102	SWING ARM END
103	P0588103	BRUSH
104	PSB117M	BUTTON HD CAP SCR M5-.8 X 8
105	P0588105	SWING ARM END
106	P0588106	EXTENSION SWING ARM
107	P0588107	SWING ARM ADJ SCR M20-2.5
108	PN28M	HEX NUT M20-2.5
117	PW01M	FLAT WASHER 8MM
118	PLN04M	LOCK NUT M8-1.25
188	P0588188	HEX BOLT M8-1.25 X 100
189	P0588189	STOP BLOCK
240	PSS02M	SET SCREW M6-1 X 6
262	P6204	BALL BEARING 6204ZZ
265	P0588265	SWING ARM SHAFT

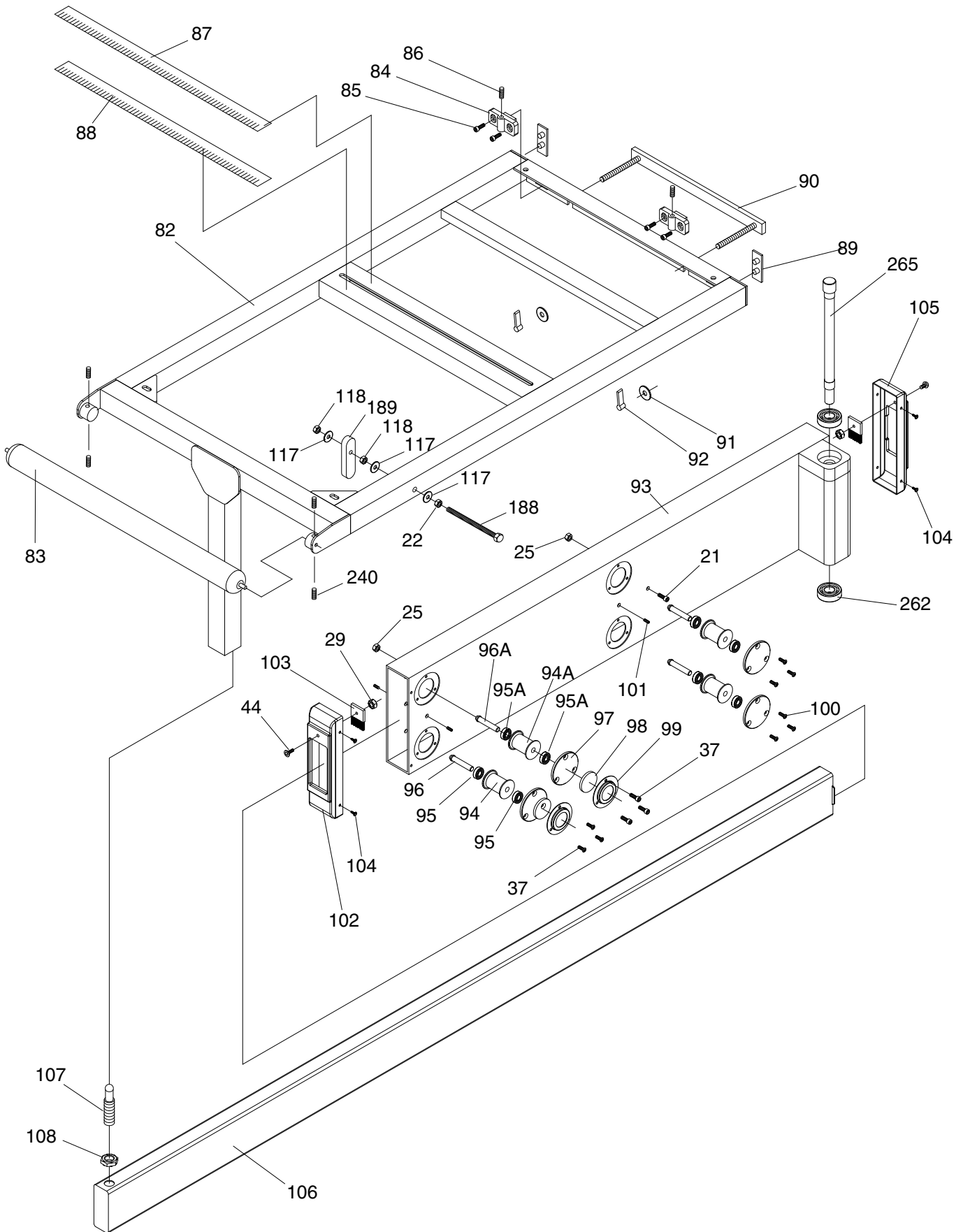

Crosscut Fence

REF	PART #	DESCRIPTION
29	PN01M	HEX NUT M6-1
109	P0588109	STOP PLATE
109-1	PSS02M	SET SCREW M6-1 X 6
110	P0588110	NYLON PAD
111	P0588111	KNOB M6-1 X 35
114	P0588114	CLAMPING BASE
115	P0588115	T-NUT M6-1
116	P0588116	CLAMPING ARBOR
117	PW01M	FLAT WASHER 8MM
118	PLN04M	LOCK NUT M8-1.25
119A	P0588119A	SCALE (LONG)
120	P0588120	CROSSCUT FENCE

REF	PART #	DESCRIPTION
121	PSS04M	SET SCREW M6-1 X 12
122A	P0588122A	FRONT SUPPORT BLOCK
123	P0588123	T-BOLT M10-1.5
124	P0588124	KNOB M10-1.5
125A	P0588125A	LOCK T-BOLT M10-1.5 X 25
126A	P0588126A	SCALE(SHORT)
127	P0588127	CROSS CUTTING FENCE-SHORT
128	P0588128	LOCK PLATE
129	PSS29M	SET SCREW M6-1 X 35
130	P0588130	CROSS FENCE SUPPORT PLATE
138A	P0588138A	STOP PLATE
263	P0588263	SCALE TUBE

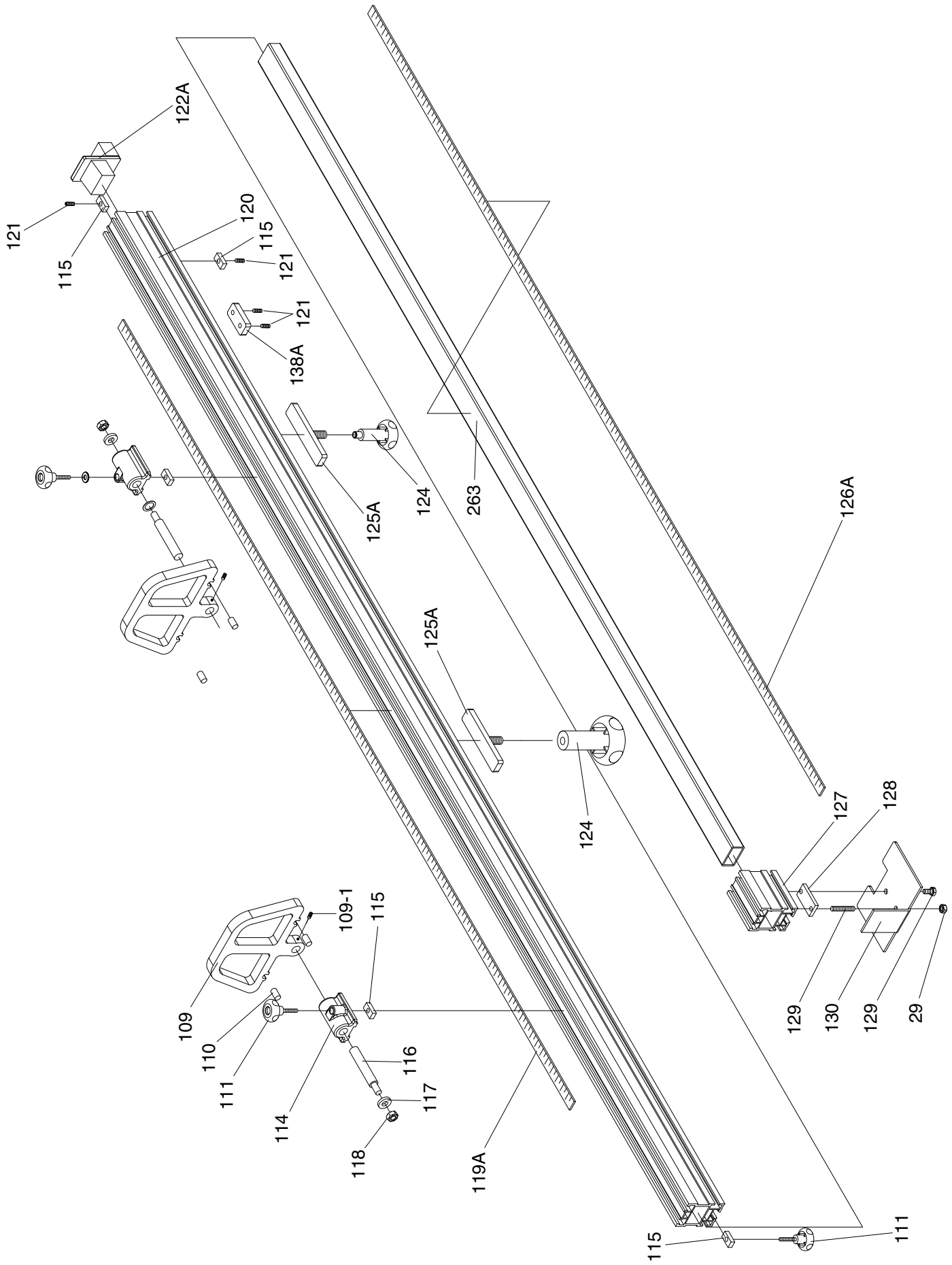

Rip Fence

REF	PART #	DESCRIPTION
28	PN13M	HEX NUT M16-2
104	PSB117M	BUTTON HD CAP SCR M5-.8 X 8
132A	P0588132A	RIP FENCE BASE
133	PR06M	EXT. RETAINING RING 16MM
134	P0588134	WARNING LABEL PLATE
135	P0588135	RIVET
136	PEC07M	E-CLIP 7MM
137	P0588137	HANDLE
139	P0588139	COMPRESSION SPRING
140	P0588140	KNOB M14-1.75
142	P0588142	HANDLE
143	P0588143	ECCENTRIC

REF	PART #	DESCRIPTION
144	P0588144	ROLLER
145	PB33M	HEX BOLT M12-1.75 X 50
146	PSB14M	CAP SCREW M8-1.25 X 20
147	PB28M	HEX BOLT M8-1.25 X 60
148	P0588148	RIP FENCE PLATE
149	P0588149	LOCK BLOCK (LONG)
150	P0588150	LOCK BLOCK (SHORT)
151	P0588151	ECCENTRIC SHAFT
152	P0588152	HOLD PLATE
153A	P0588153A	ECCENTRIC
305	PN09M	HEX NUT M12-1.75
306	PTLW12M	EXT TOOTH WASHER 12MM

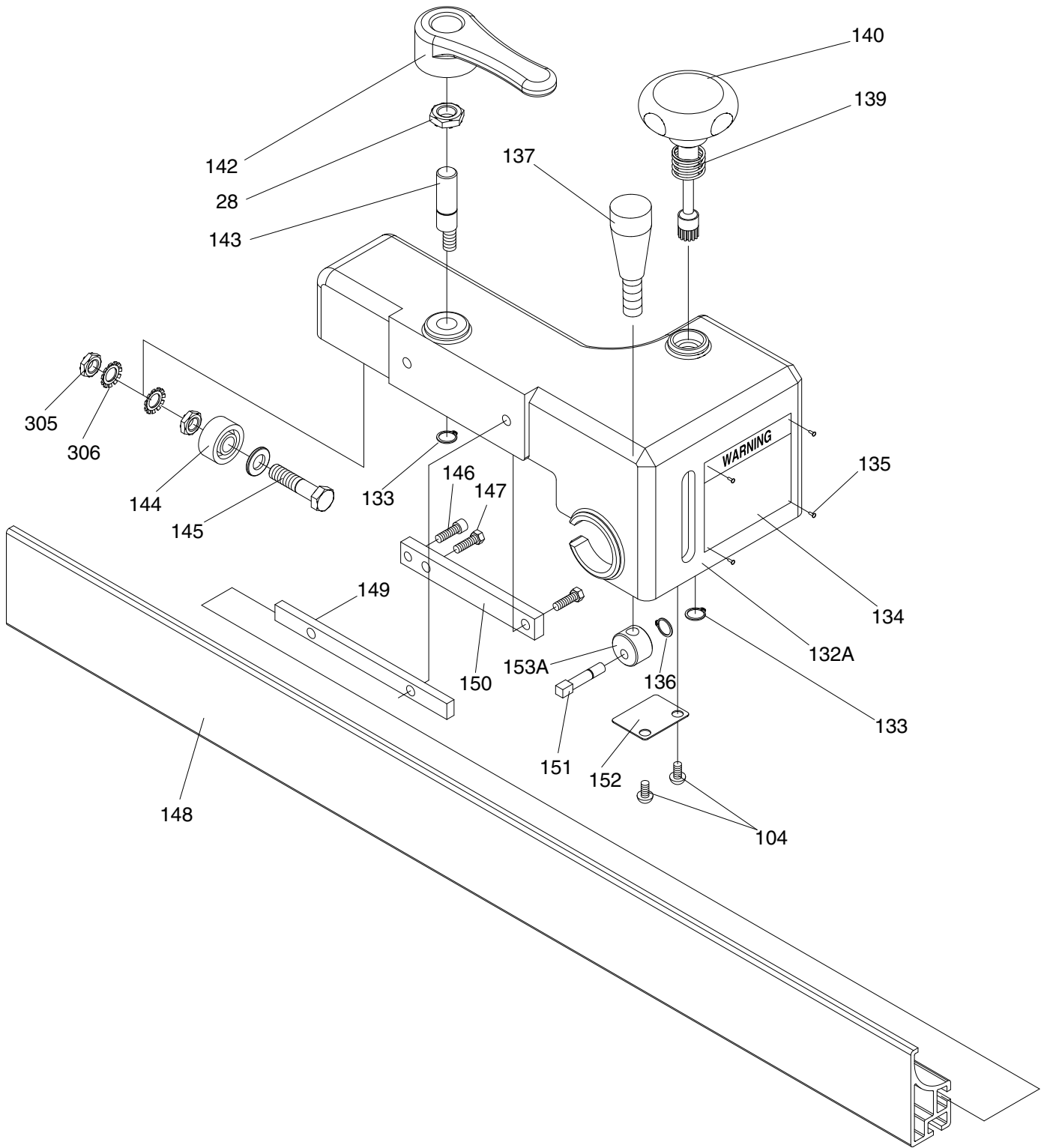

Tilt Assembly

REF	PART #	DESCRIPTION
3	PW01M	FLAT WASHER 8MM
22	PN03M	HEX NUT M8-1.25
29	PN01M	HEX NUT M6-1
40	PN09M	HEX NUT M12-1.75
41	PW06M	FLAT WASHER 12MM
44	PSB01M	CAP SCREW M6-1 X 16
118	PLN04M	LOCK NUT M8-1.25
154	P0588154	STEEL CABLE WHEEL
155	P0588155	TORSION SPRING
156	PSB40M	CAP SCREW M8-1.25 X 35
157	PSB136M	CAP SCREW M10-1.5 X 90
158	P0588158	SCALE
159	P0588159	STEEL CABLE
160	P0588160	HAND WHEEL
161	P0588161	HAND WHEEL COLLAR
162	P0588162	SHAFT NUT
163	P0588163	SHAFT NUT BASE
164	P0588164	TW-NUT
165	P0588165	LEAD SCREW NUT
166	P0588166	LEAD SCREW TW-16 8T/ INCH
167	P0588167	STEEL CABLE JACKET
168	PSB64M	CAP SCREW M10-1.5 X 25
169	P0588169	COVER SUPPORT M6-1 X 25
170	P0588170	SET SHAFT
171	P0588171	BODY ARBOR

REF	PART #	DESCRIPTION
172	P0588172	GATHER PLATE
173	P0588173	CRANK ARM
174	P0588174	PULLEY COLLAR
175	PSB40M	CAP SCREW M8-1.25 X 35
176	P0588176	GATHER BOLT M8-1.25 X 35
177	PLN07M	LOCK NUT 16-2
178	P0588178	WORM
179	P0588179	WORM GEAR
180	P0588180	COPPER SLEEVE
181	PB132M	HEX BOLT M16-2 X 40
182	P0588182	GEAR BOX
183	PSS11	SET SCREW 1/4-20 X 1/4
184	P0588184	COPPER SLEEVE
185	PSS59M	SET SCREW M8-1.25 X 14
186	P0588186	HAND WHEEL SHAFT
187	P0588187	HAND WHEEL
190	P0588190	FOLDABLE HANDLE HL-80
191	PSS51M	SET SCREW M4-.7 X 8
192	P0588192	ARBOR PLATE
264	P0588264	KNOB M10-1.5
266	P0588266	COVER (UPPER)
275	P0588275	ROTATE PART LOCK
276	PRP42M	ROLL PIN 3 X 20
277	PSB14M	CAP SCREW M8-1.25 X 20

Motor Assembly

REF	PART #	DESCRIPTION
22	PN03M	HEX NUT M8-1.25
24	PB116M	HEX BOLT M10-1.5 X 45
25	PN02M	HEX NUT M10-1.5
91	PW04M	FLAT WASHER 10MM
101	P0588101	NYLON SCREW M12-1.75 X 12
118	PLN04M	LOCK NUT M8-1.25
164	P0588164	TW-NUT
193	P0588193	DUST COVER
194	PCAP11M	CAP SCREW M8-1.25 X 16
195	PFH11M	FLAT HD SCR M8-1.25 X 15
196	PN21M	HEX NUT M16-2 (LH)
197	P0588197	ARBOR FLANGE
198	PRP74M	ROLL PIN 4 X 8
200	P0588200	BLADE ARBOR
201	P6004-2RS	BALL BEARING 6004-2RS
203	PCAP46M	CAP SCREW M4-.7 X 40
204	PN04M	HEX NUT M4-.7
205	P0588205	LIMIT SWITCH
206	P0588206	V-BELT 3VX-265
207	P0588207	MOTOR PULLEY
208	PR71M	EXT RETAINING RING 60MM
209	PSS16M	SET SCREW M8-1.25 X 10
211	P0588211	RIVING KNIFE HOLDER
212	P0588212	RIVING BRACKET
213	PCB25M	CARRIAGE BOLT M12-1.75 X 35
214	PSS01M	SET SCREW M6-1 X 10
215	PK42M	KEY 6 X 6 X 30
216	P0588216	MOTOR 7.5HP-3PH (G0588)
216	P0591216	MOTOR 5HP-1PH (G0591)
216-1	P0588216-1	MOTOR FAN (G0588)
216-1	P0588216-1	MOTOR FAN (G0588)
216-2	P0588216-2	MOTOR FAN COVER (G0588)
216-2	P0588216-2	MOTOR FAN COVER (G0588)
216-3	PC045A	R CAPACITOR 45M 250V (G0591)

REF	PART #	DESCRIPTION
216-4	PC600	S CAPACITOR 600M 125V (G0591)
216-5	P0591216-5	R CAPACITOR COVER (G0591)
216-6	P0591216-6	S CAPACITOR COVER (G0591)
216-7	P0588216-7	WIRING CONNECT BOX (G0588)
216-7	P0588216-7	WIRING CONNECT BOX (G0588)
217	PB74M	HEX BOLT M10-1.5 X 20
218	PLW06M	LOCK WASHER 10MM
219	P0588219	SPANNER NUT M25-1.5
220	P0588220	MOTOR PLATE
221	PR09M	EXT RETAINING RING 20MM
222	P0588222	ROTATE HOUSING
223	PRP08M	ROLL PIN 6 X 30
224	P0588224	BLADE GUARD
227	P0588227	ADJUST HANDLE M8-1.25 X 30
228	P0588228	RIVING KNIFE
229	P0588229	COVER LOCK BLOCK
269	P0588269	SWTCH CRD 1.0 X 2C X 7500MM
270	P0588270	POWER CRD 1.5 X 4C X 7000MM
271	P0588271	MOTOR CRD 1.5 X 4C X 7000MM
272	P0588272	SWTCH CRD 1.0 X 4C X 7000MM
280	P0588280	WAVE WASHER 60MM
281	PAW02M	HEX WRENCH 2MM
282	PAW03M	HEX WRENCH 3MM
283	PAW06M	HEX WRENCH 6MM
284	P0588284	T-KEY WRENCH 4MM
285	P0588285	T-KEY WRENCH 5MM
286	P0588286	T-KEY WRENCH 6MM
287	PWR13	WRENCH 13MM
288	P0588288	WRENCH 19MM
289	PWR1012	WRENCH 10 X 12
290	PWR1417	WRENCH 14 X 17
291	PWR2224	WRENCH 22 X 24
305	PN09M	HEX NUT M12-1.75

Arbor Assembly

REF	PART #	DESCRIPTION
3	PW01M	FLAT WASHER 8MM
25	PN02M	HEX NUT M10-1.5
118	PLN04M	LOCK NUT M8-1.25
174	P0588174	PULLEY COLLAR
230	P0588230	SCORING BLADE WASHER
232	P0588232	SCORING ARBOR
233	PK47M	KEY 4 X 4 X 15
234	PR29M	INT RETAINING RING 32MM
235	P0588235	WAVE WASHER 15MM
236	P0588236	BLADE LINK SHAFT
237	P6002	BALL BEARING 6002ZZ
238	P0588238	BLADE LINK SHAFT
239	P0588239	TORSION SPRING
240	PSS05M	SET SCREW M5-.8 X 10
241	P0588241	SLEEVE
242	PSB12M	CAP SCREW M8-1.25 X 40
243	P0588243	LINK SHAFT BASE

REF	PART #	DESCRIPTION
244	P0588244	ECCENTRIC
245	P0588245	SPECIAL SET SCREW M8-1.25 X 25
246	PR05M	EXT RETAINING RING 15MM
247	P0588247	SCORING PULLEY
248	P0588248	HEX NUT M8-1.25 (LH)
249	PSB72M	CAP SCREW M10-1.5 X 30
250	P0588250	IDLE WHEEL
251	P6000	BALL BEARING 6000ZZ
252	PR40M	INT RETAINING RING 26MM
253	PSB130M	CAP SCREW M10-1.5 X 16
254	P0588254	FLAT BELT PULLEY
255	PK99M	KEY 6 X 6 X 15
256	P0588256	PULLEY SUPPORT
257	P0588257	EXTENSION SPRING
258	P0588258	FLAT BELT T150-920-T1
268	PSS05M	SET SCREW M5-.8 X 10

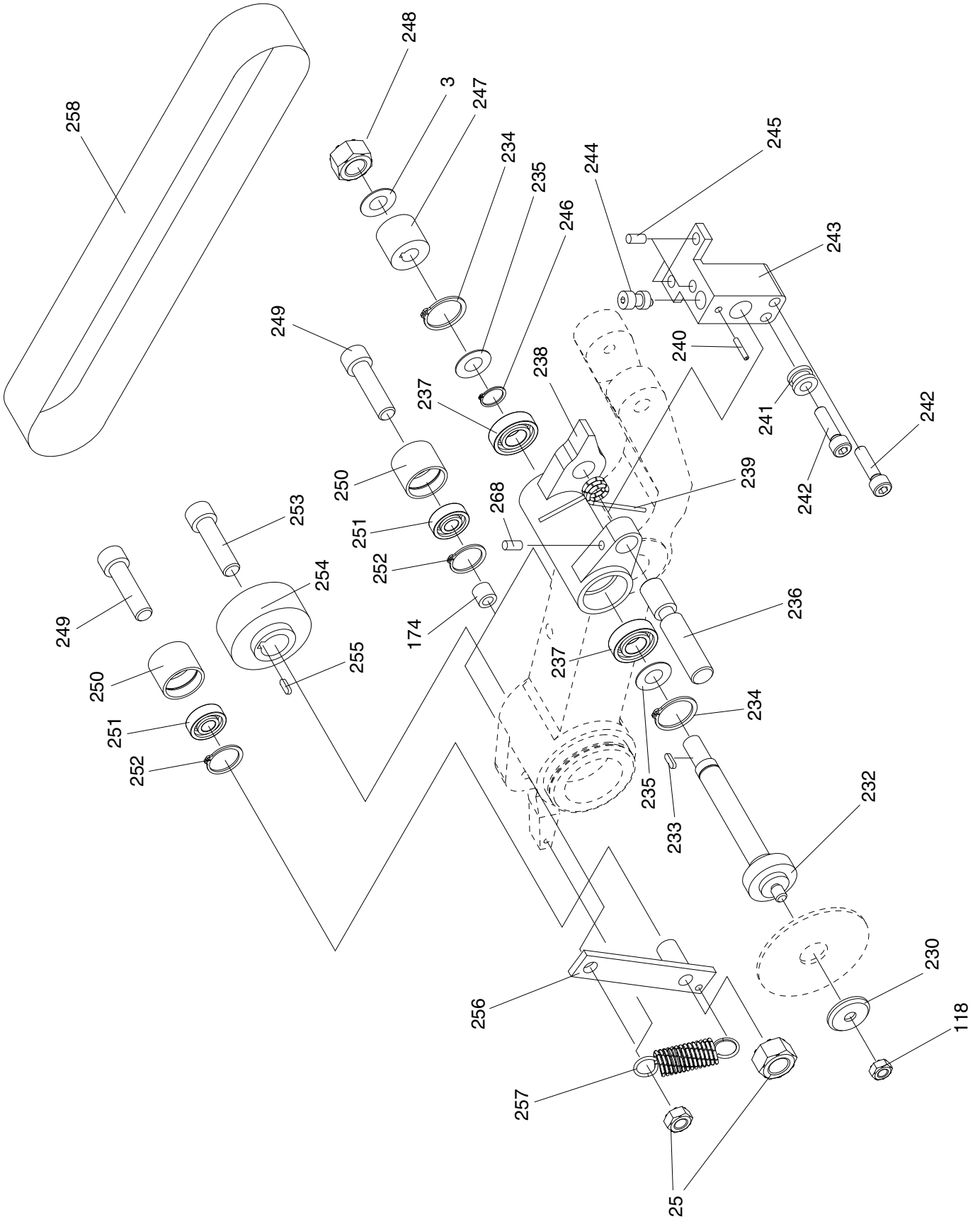

WARRANTY AND RETURNS

Grizzly Industrial, Inc. warrants every product it sells for a period of **1 year** to the original purchaser from the date of purchase. This warranty does not apply to defects due directly or indirectly to misuse, abuse, negligence, accidents, repairs or alterations or lack of maintenance. This is Grizzly's sole written warranty and any and all warranties that may be implied by law, including any merchantability or fitness, for any particular purpose, are hereby limited to the duration of this written warranty. We do not warrant or represent that the merchandise complies with the provisions of any law or acts unless the manufacturer so warrants. In no event shall Grizzly's liability under this warranty exceed the purchase price paid for the product and any legal actions brought against Grizzly shall be tried in the State of Washington, County of Whatcom.

We shall in no event be liable for death, injuries to persons or property or for incidental, contingent, special, or consequential damages arising from the use of our products.

To take advantage of this warranty, contact us by mail or phone and give us all the details. We will then issue you a "Return Number," which must be clearly posted on the outside as well as the inside of the carton. We will not accept any item back without this number. Proof of purchase must accompany the merchandise.

The manufacturers reserve the right to change specifications at any time because they constantly strive to achieve better quality equipment. We make every effort to ensure that our products meet high quality and durability standards and we hope you never need to use this warranty.

Please feel free to write or call us if you have any questions about the machine or the manual.

Thank you again for your business and continued support. We hope to serve you again soon.



WARRANTY CARD

Name _____
 Street _____
 City _____ State _____ Zip _____
 Phone # _____ Email _____ Invoice # _____
 Model # _____ Order # _____ Serial # _____

The following information is given on a voluntary basis. It will be used for marketing purposes to help us develop better products and services. **Of course, all information is strictly confidential.**

1. How did you learn about us?

Advertisement Friend Catalog
 Card Deck Website Other: _____

2. Which of the following magazines do you subscribe to?

<input type="checkbox"/> Cabinet Maker	<input type="checkbox"/> Popular Mechanics	<input type="checkbox"/> Today's Homeowner
<input type="checkbox"/> Family Handyman	<input type="checkbox"/> Popular Science	<input type="checkbox"/> Wood
<input type="checkbox"/> Hand Loader	<input type="checkbox"/> Popular Woodworking	<input type="checkbox"/> Wooden Boat
<input type="checkbox"/> Handy	<input type="checkbox"/> Practical Homeowner	<input type="checkbox"/> Woodshop News
<input type="checkbox"/> Home Shop Machinist	<input type="checkbox"/> Precision Shooter	<input type="checkbox"/> Woodsmith
<input type="checkbox"/> Journal of Light Cont.	<input type="checkbox"/> Projects in Metal	<input type="checkbox"/> Woodwork
<input type="checkbox"/> Live Steam	<input type="checkbox"/> RC Modeler	<input type="checkbox"/> Woodworker West
<input type="checkbox"/> Model Airplane News	<input type="checkbox"/> Rifle	<input type="checkbox"/> Woodworker's Journal
<input type="checkbox"/> Modeltec	<input type="checkbox"/> Shop Notes	<input type="checkbox"/> Other: _____
<input type="checkbox"/> Old House Journal	<input type="checkbox"/> Shotgun News	

3. What is your annual household income?

\$20,000-\$29,000 \$30,000-\$39,000 \$40,000-\$49,000
 \$50,000-\$59,000 \$60,000-\$69,000 \$70,000+

4. What is your age group?

20-29 30-39 40-49
 50-59 60-69 70+

5. How long have you been a woodworker/metalworker?

0-2 Years 2-8 Years 8-20 Years 20+ Years

6. How many of your machines or tools are Grizzly?

0-2 3-5 6-9 10+

7. Do you think your machine represents a good value?

Yes No

8. Would you recommend Grizzly Industrial to a friend?

Yes No

9. Would you allow us to use your name as a reference for Grizzly customers in your area?

Note: We never use names more than 3 times. Yes No

10. Comments: _____

CUT ALONG DOTTED LINE

FOLD ALONG DOTTED LINE



Place
Stamp
Here



GRIZZLY INDUSTRIAL, INC.
P.O. BOX 2069
BELLINGHAM, WA 98227-2069



FOLD ALONG DOTTED LINE

Send a Grizzly Catalog to a friend:

Name _____
Street _____
City _____ State _____ Zip _____

TAPE ALONG EDGES--PLEASE DO NOT STAPLE

grizzly.com

TOOL WEBSITE

Buy Direct and Save with Grizzly® – Trusted, Proven and a Great Value!

*Visit Our Website Today And Discover Why
Grizzly® Is The Industry Leader!*

- SECURE ORDERING
- ORDERS SHIPPED WITHIN 24 HOURS
- E-MAIL RESPONSE WITHIN ONE HOUR

-OR-

Call Today For A **FREE**
Full Color Catalog

1-800-523-4777

