

READ THIS FIRST



Model G0657/G0658

*****IMPORTANT UPDATE*****

For Machines Mfg. Since March, 2013
and Owner's Manual Printed February, 2008

The following changes were made to this machine:

- Changed the circuit boards and electrical wiring.
- Changed the motor circuit board box grommet to a strain relief.

Aside from this information, all other content in the owner's manual applies and **MUST** be read and understood for your own safety. **IMPORTANT: Keep this update with the owner's manual for future reference.**

For questions or help, contact our Tech Support at (570) 546-9663 or techsupport@grizzly.com.

Changed Parts

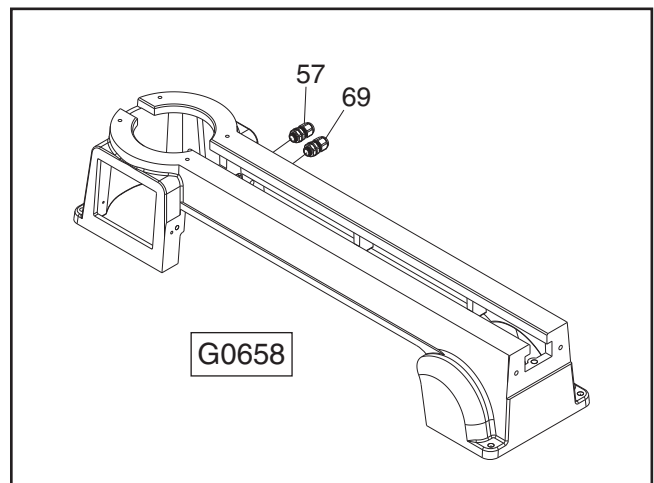
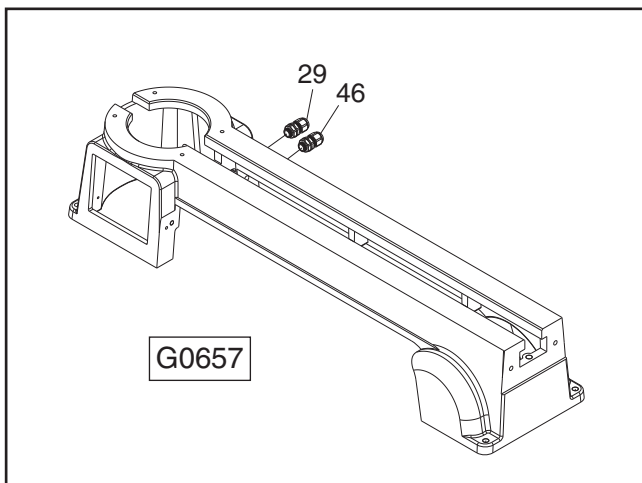

REF	PART #	DESCRIPTION
29	P0657029	STRAIN RELIEF PGA13.5-11
46	P0657046	STRAIN RELIEF MG16A-10B-ST

REF	PART #	DESCRIPTION
57	P0658057	STRAIN RELIEF MG20A-14B-ST
69	P0657046	STRAIN RELIEF MG16A-10B-ST

COPYRIGHT © MARCH, 2013 BY GRIZZLY INDUSTRIAL, INC.
**WARNING: NO PORTION OF THIS MANUAL MAY BE REPRODUCED IN ANY SHAPE
OR FORM WITHOUT THE WRITTEN APPROVAL OF GRIZZLY INDUSTRIAL, INC.**
#TS15702 PRINTED IN TAIWAN

G0657/G0658 Wiring Diagram

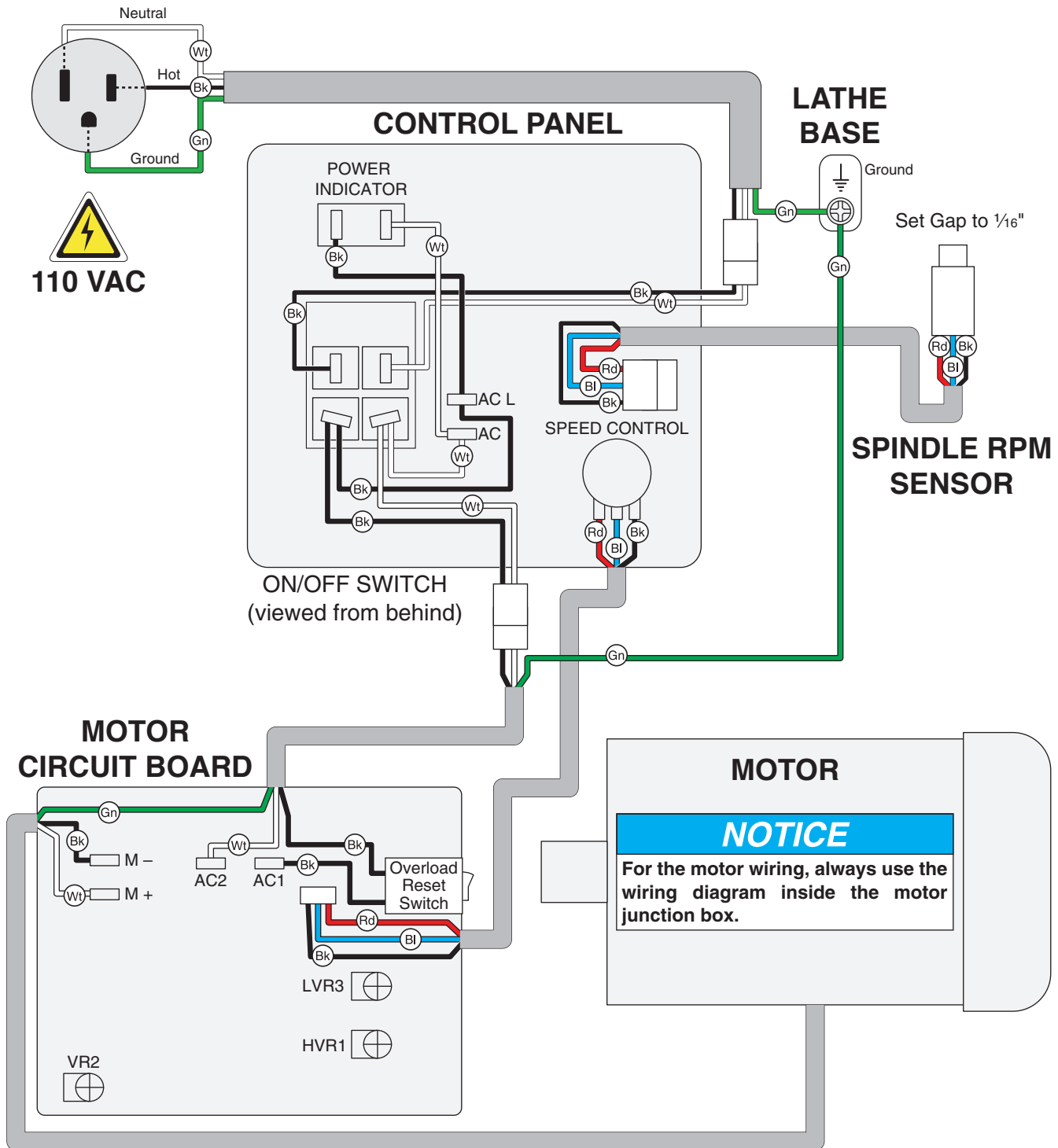

Grizzly **Industrial, Inc.**®

MODEL G0657/G0658 BENCHTOP LATHE

OWNER'S MANUAL

(For models manufactured since 5/13)

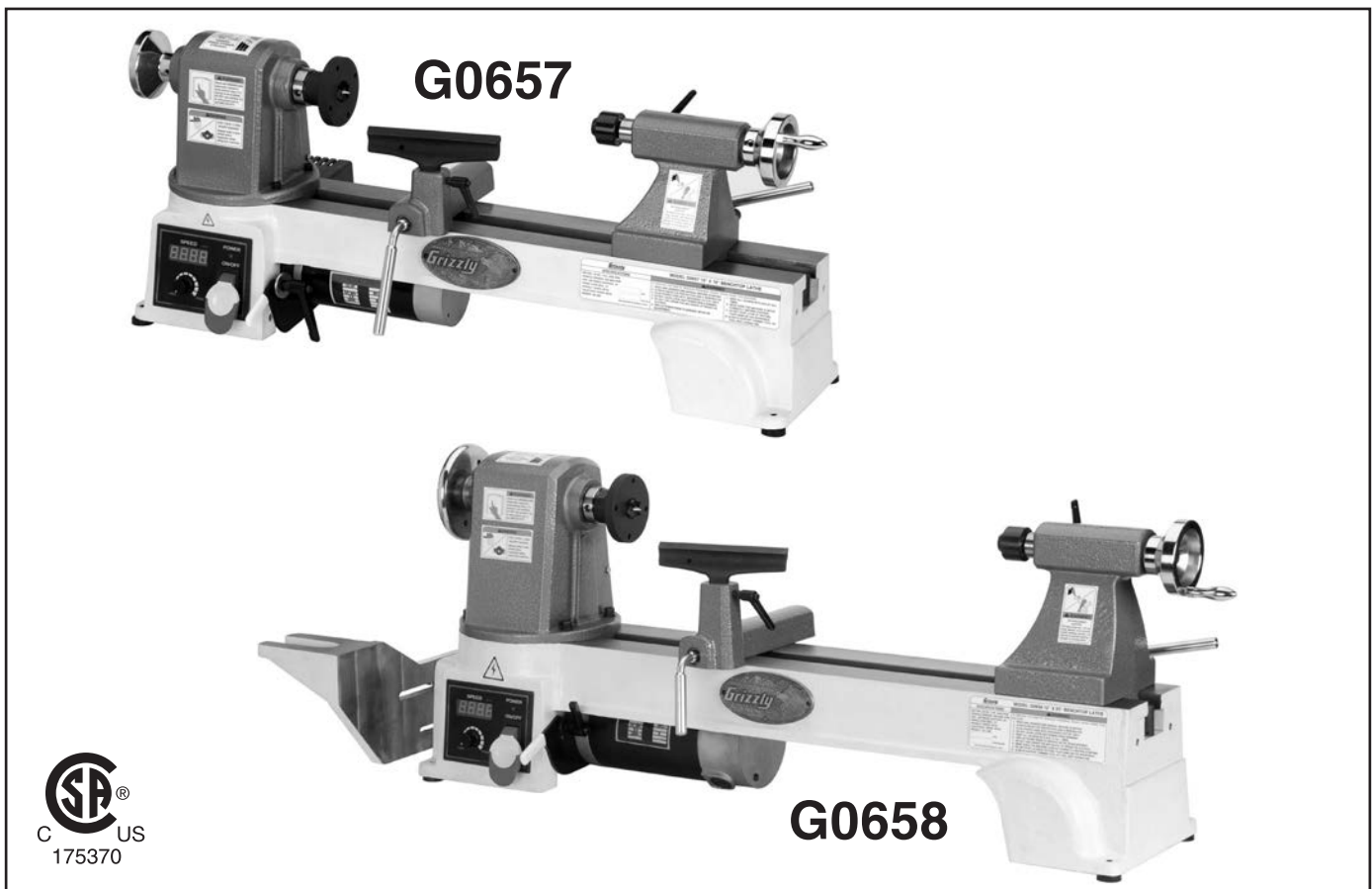

COPYRIGHT © FEBRUARY, 2008 BY GRIZZLY INDUSTRIAL, INC., REVISED MARCH, 2013 (TS)

**WARNING: NO PORTION OF THIS MANUAL MAY BE REPRODUCED IN ANY SHAPE
OR FORM WITHOUT THE WRITTEN APPROVAL OF GRIZZLY INDUSTRIAL, INC.**

#JB10401 PRINTED IN TAIWAN



WARNING!

This manual provides critical safety instructions on the proper setup, operation, maintenance, and service of this machine/tool. Save this document, refer to it often, and use it to instruct other operators.

Failure to read, understand and follow the instructions in this manual may result in fire or serious personal injury—including amputation, electrocution, or death.

The owner of this machine/tool is solely responsible for its safe use. This responsibility includes but is not limited to proper installation in a safe environment, personnel training and usage authorization, proper inspection and maintenance, manual availability and comprehension, application of safety devices, cutting/sanding/grinding tool integrity, and the usage of personal protective equipment.

The manufacturer will not be held liable for injury or property damage from negligence, improper training, machine modifications or misuse.



WARNING!

Some dust created by power sanding, sawing, grinding, drilling, and other construction activities contains chemicals known to the State of California to cause cancer, birth defects or other reproductive harm. Some examples of these chemicals are:

- **Lead from lead-based paints.**
- **Crystalline silica from bricks, cement and other masonry products.**
- **Arsenic and chromium from chemically-treated lumber.**

Your risk from these exposures varies, depending on how often you do this type of work. To reduce your exposure to these chemicals: Work in a well ventilated area, and work with approved safety equipment, such as those dust masks that are specially designed to filter out microscopic particles.

Table of Contents

INTRODUCTION.....	2	SECTION 5: ACCESSORIES.....	30
Foreword.....	2	SECTION 6: MAINTENANCE.....	32
Contact Info.....	2	Schedule.....	32
Functional Overview.....	2	Cleaning.....	32
G0657/G0658 Identification.....	3	Unpainted Cast Iron.....	32
G0657 Machine Data Sheet.....	4	Lubrication.....	32
G0658 Machine Data Sheet.....	6	SECTION 7: SERVICE.....	33
SECTION 1: SAFETY.....	8	Troubleshooting.....	33
Safety Instructions for Machinery.....	8	Motor & Electrical.....	33
Additional Safety for Wood Lathes.....	10	Wood Lathe Operation.....	34
SECTION 2: POWER SUPPLY.....	11	Changing Belt.....	35
Availability.....	11	SECTION 8: WIRING.....	37
Full-Load Current Rating.....	11	Wiring Safety Instructions.....	37
110V Circuit Requirements.....	11	G0657/G0658 Wiring Diagram.....	38
Grounding & Plug Requirements.....	12	SECTION 9: PARTS.....	39
Extension Cords.....	12	G0657 Main.....	39
SECTION 3: SETUP.....	13	G0657 Labels.....	42
Unpacking.....	13	G0658 Main.....	43
Inventory.....	13	G0658 Labels.....	46
Cleanup.....	14	WARRANTY AND RETURNS.....	49
Site Considerations.....	15		
Mounting.....	16		
Assembly.....	17		
Test Run.....	18		
SECTION 4: OPERATIONS.....	19		
Disabling Switch.....	19		
Basic Controls.....	20		
Changing Speed Ranges.....	21		
Adjusting Tailstock.....	22		
Adjusting Tool Rest.....	22		
Installing/Removing Spur Center.....	23		
Installing/Removing Live Center.....	23		
Removing/Installing Faceplate.....	24		
Selecting Turning Tools.....	25		
Outboard Turning (G0658 Only).....	26		
Spindle Turning.....	27		
Faceplate Turning.....	28		
Sanding/Finishing.....	29		

INTRODUCTION

Foreword

We are proud to offer the G0657/G0658 Benchtop Lathe. This machine is part of a growing Grizzly family of fine woodworking machinery. When used according to the guidelines set forth in this manual, you can expect years of trouble-free, enjoyable operation and proof of Grizzly's commitment to customer satisfaction.

The specifications, drawings, and photographs illustrated in this manual represent the Model G0657/G0658 as supplied when the manual was prepared. However, owing to Grizzly's policy of continuous improvement, changes may be made at any time with no obligation on the part of Grizzly.

For your convenience, we always keep current Grizzly manuals available on our website at www.grizzly.com. Any updates to your machine will be reflected in these manuals as soon as they are complete.

Contact Info

If you have any comments regarding this manual, please write to us at the address below:

Grizzly Industrial, Inc.
c/o Technical Documentation Manager
P.O. Box 2069
Bellingham, WA 98227-2069
Email: manuals@grizzly.com

We stand behind our machines. If you have any service questions or parts requests, please call or write us at the location listed below.

Grizzly Industrial, Inc.
1203 Lycoming Mall Circle
Muncy, PA 17756
Phone: (570) 546-9663
Fax: (800) 438-5901
E-Mail: techsupport@grizzly.com
Web Site: <http://www.grizzly.com>

Functional Overview

A wood lathe is used to turn wood stock. The primary components of the wood lathe are the headstock, the tailstock, and the tool rest.

For most turning procedures, a round or nearly-round workpiece is clamped between the headstock spur center and the tailstock live center. The tool rest is positioned to provide stability to the chisel or other cutting tool while it is pressed into the workpiece. The lathe is turned **ON**, which causes the spindle to rotate. Pressing the cutting tool into the workpiece while it is turning cuts grooves around the circumference of the stock. Moving the cutting tool along the length of the workpiece allows the user to shape the workpiece into perfect cylinders, tapers, and intricate designs.

Another option is faceplate turning. Faceplate turning is used to create plates, bowls, and other shallow or open-faced forms. In this method, the tailstock is moved completely out of the way and the workpiece is attached to the faceplate on the headstock. Again, the tool rest is positioned to provide support to the cutting tool. The outboard turning attachment on the Model G0658 provides the option for turning large workpieces without the lathe bed interfering with the operation.

Once a rough shape is created on the lathe, it can be sanded smooth by moving the tool rest out of the way and carefully sanding along the length of the workpiece while the lathe is rotating.

To allow for greater versatility, the spindle speed can be adjusted by repositioning the belt position in the head stock and by turning the speed adjustment knob on the control panel.



G0657/G0658 Identification

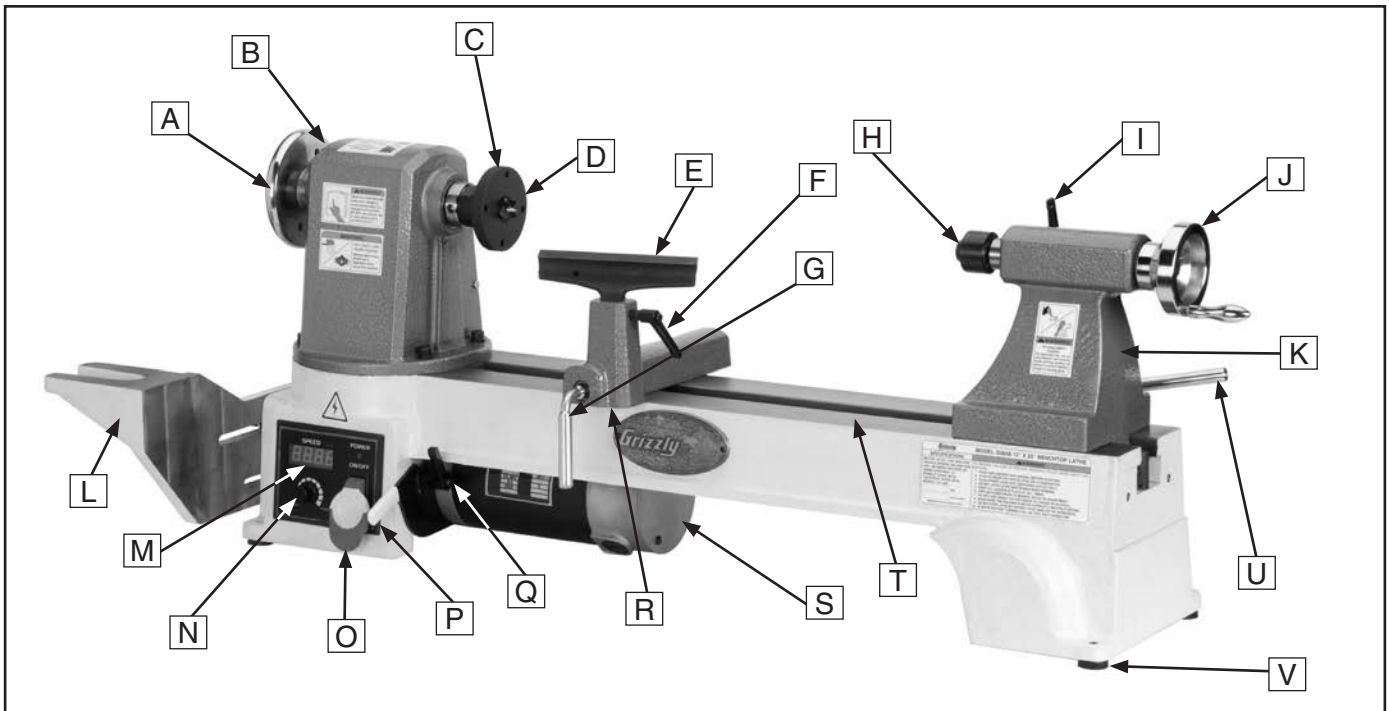

Figure 1. Model G0657/G0658 Identification.

- | | |
|---------------------------------|--|
| A. Spindle Handwheel | L. Outboard Tool Rest Mount (G0658 only) |
| B. Headstock | M. Digital Speed Display |
| C. Faceplate | N. Speed Control Dial |
| D. Spur Center | O. ON/OFF Switch w/Disabling Key |
| E. Tool Rest | P. Belt Tension Lever |
| F. Tool Rest Lock Handle | Q. Belt Tension Lock Handle |
| G. Tool Rest Base Release Lever | R. Tool Rest Base |
| H. Live Center | S. Motor |
| I. Quill Lock Handle | T. Lathe Bed |
| J. Quill Handwheel | U. Tailstock Release Lever |
| K. Tailstock | V. Leveling Foot |

⚠️ WARNING

To reduce the risk of serious injury when using this machine:

- Read and understand this entire manual before starting.
- Wear eye protection.
- Do not wear gloves, necktie, or loose clothing.
- Tighten all locks before operating.
- Rotate workpiece by hand before applying power.
- Rough out workpiece before installing on faceplate.
- Do not use split workpieces or ones containing knots.
- Use lowest speed when starting new workpiece.





MACHINE DATA SHEET

Customer Service #: (570) 546-9663 · To Order Call: (800) 523-4777 · Fax #: (800) 438-5901

MODEL G0657 10 X 16 HEAVY-DUTY BENCH-TOP WOOD LATHE

Product Dimensions:

Weight..... 79 lbs.
 Width (side-to-side) x Depth (front-to-back) x Height..... 36 x 13-1/2 x 12 in.
 Footprint (Length x Width)..... 7-3/4 x 31-1/2 in.

Shipping Dimensions:

Type..... Cardboard Box
 Content..... Machine
 Weight..... 90 lbs.
 Length x Width x Height..... 35 x 15 x 16 in.
 Must Ship Upright..... No

Electrical:

Power Requirement..... 110V, Single-Phase, 60 Hz
 Prewired Voltage..... 110V
 Full-Load Current Rating..... 2.5A
 Minimum Circuit Size..... 15A
 Connection Type..... Cord & Plug
 Power Cord Included..... Yes
 Power Cord Length..... 6 ft.
 Power Cord Gauge..... 16 AWG
 Plug Included..... Yes
 Included Plug Type..... 5-15
 Switch Type..... Paddle Safety Switch w/Removable Key

Motors:

Main

Type..... Universal DC
 Horsepower..... 1/2 HP
 Phase..... Single-Phase
 Amps..... 2.5A
 Speed..... 2500 RPM
 Power Transfer Belt Drive
 Bearings..... Shielded & Permanently Lubricated

Main Specifications:

Operation Information

Swing Over Bed..... 10 in.
 Dist Between Centers..... 16 in.
 Swing Over Tool Rest..... 7 in.
 Swing Over Tool Rest Base..... 7-1/4 in.
 No of Spindle Speeds..... 3
 Spindle Speed Range..... 300 – 3600 RPM



Spindle Information

Spindle Taper..... MT#2
 Spindle Thread Size..... 1 in.
 Spindle TPI..... 8 TPI
 Spindle Thread Direction..... Right Hand
 Spindle Bore..... 0.433 in.
 Type of Included Spindle Center..... Spur
 Outboard Spindle Thread Direction..... Left Hand
 Outboard Spindle Size..... 3/4 in.
 Outboard Spindle TPI..... 16 TPI

Tool Rest Information

Tool Rest Width..... 5-7/8 in.
 Tool Rest Post Diameter..... 5/8 in.
 Tool Rest Post Length..... 2-7/16 in.
 Tool Rest Base Height..... 1-5/16 in.

Tailstock Information

Tailstock Taper..... MT#2
 Type of Included Tailstock Center..... Live

Construction

Bed..... Precision-Ground Cast Iron
 Headstock..... Cast Iron & Steel
 Tailstock..... Cast Iron & Steel
 Paint..... Enamel

Other Related Information

Bed Width..... 7-7/8 in.
 Faceplate Size..... 3.15 in.

Other Specifications:

Country Of Origin Taiwan
 Warranty 1 Year
 Approximate Assembly & Setup Time 30 Minutes
 Serial Number Location ID Label on Lathe Bed
 ISO 9001 Factory No
 CSA Certified Yes





MACHINE DATA SHEET

Customer Service #: (570) 546-9663 · To Order Call: (800) 523-4777 · Fax #: (800) 438-5901

MODEL G0658 12 X 20 HEAVY-DUTY BENCH-TOP WOOD LATHE

Product Dimensions:

Weight..... 121 lbs.
Width (side-to-side) x Depth (front-to-back) x Height..... 45-1/2 x 15-1/2 x 16 in.
Footprint (Length x Width)..... 8-1/2 x 35 in.

Shipping Dimensions:

Type..... Cardboard Box
Content..... Machine
Weight..... 132 lbs.
Length x Width x Height..... 38 x 16 x 17 in.
Must Ship Upright..... No

Electrical:

Power Requirement..... 110V, Single-Phase, 60 Hz
Prewired Voltage..... 110V
Full-Load Current Rating..... 3.2A
Minimum Circuit Size..... 15A
Connection Type..... Cord & Plug
Power Cord Included..... Yes
Power Cord Length..... 6 ft.
Power Cord Gauge..... 16 AWG
Plug Included..... Yes
Included Plug Type..... 5-15
Switch Type..... Paddle Safety Switch w/Removable Key

Motors:

Main

Type..... Universal DC
Horsepower..... 3/4 HP
Phase..... Single-Phase
Amps..... 3.2A
Speed..... 2500 RPM
Power Transfer Belt Drive
Bearings..... Shielded & Permanently Lubricated

Main Specifications:

Operation Information

Swing Over Bed..... 12 in.
Dist Between Centers..... 20 in.
Swing Over Tool Rest..... 9 in.
Swing Over Tool Rest Base..... 9 in.
No of Spindle Speeds..... 3
Spindle Speed Range..... 300 – 3600 RPM
Floor to Center Height..... 11-1/2 in.



Spindle Information

Spindle Taper..... MT#2
Spindle Thread Size..... 1 in.
Spindle TPI..... 8 TPI
Spindle Thread Direction..... Right Hand
Spindle Bore..... 0.433 in.
Type of Included Spindle Center..... Spur
Outboard Spindle Thread Direction..... Left Hand
Outboard Spindle Size..... 3/4 in.
Outboard Spindle TPI..... 16 TPI

Tool Rest Information

Tool Rest Width..... 6-1/16 in.
Tool Rest Post Diameter..... 5/8 in.
Tool Rest Post Length..... 3-5/8 in.
Tool Rest Base Height..... 1-7/16 in.

Tailstock Information

Tailstock Taper..... MT#2
Type of Included Tailstock Center..... Live

Construction

Bed..... Precision-Ground Cast Iron
Headstock..... Cast Iron & Steel
Tailstock..... Cast Iron & Steel
Paint..... Enamel

Other Related Information

Bed Width..... 7-7/8 in.
Faceplate Size..... 3.15 in.

Other Specifications:

Country Of Origin Taiwan
Warranty 1 Year
Approximate Assembly & Setup Time 30 Minutes
Serial Number Location ID Label on Lathe Bed
ISO 9001 Factory No
CSA Certified Yes



SECTION 1: SAFETY

For Your Own Safety, Read Instruction Manual Before Operating This Machine

The purpose of safety symbols is to attract your attention to possible hazardous conditions. This manual uses a series of symbols and signal words intended to convey the level of importance of the safety messages. The progression of symbols is described below. Remember that safety messages by themselves do not eliminate danger and are not a substitute for proper accident prevention measures. Always use common sense and good judgment.

 **DANGER** Indicates an imminently hazardous situation which, if not avoided, **WILL** result in death or serious injury.

 **WARNING** Indicates a potentially hazardous situation which, if not avoided, **COULD** result in death or serious injury.

 **CAUTION** Indicates a potentially hazardous situation which, if not avoided, **MAY** result in minor or moderate injury. It may also be used to alert against unsafe practices.

NOTICE This symbol is used to alert the user to useful information about proper operation of the machine.

Safety Instructions for Machinery

WARNING

OWNER'S MANUAL. Read and understand this owner's manual **BEFORE** using machine.

TRAINED OPERATORS ONLY. Untrained operators have a higher risk of being hurt or killed. Only allow trained/supervised people to use this machine. When machine is not being used, disconnect power, remove switch keys, or lock-out machine to prevent unauthorized use—especially around children. Make workshop kid proof!

DANGEROUS ENVIRONMENTS. Do not use machinery in areas that are wet, cluttered, or have poor lighting. Operating machinery in these areas greatly increases the risk of accidents and injury.

MENTAL ALERTNESS REQUIRED. Full mental alertness is required for safe operation of machinery. Never operate under the influence of drugs or alcohol, when tired, or when distracted.

ELECTRICAL EQUIPMENT INJURY RISKS. You can be shocked, burned, or killed by touching live electrical components or improperly grounded machinery. To reduce this risk, only allow qualified service personnel to do electrical installation or repair work, and always disconnect power before accessing or exposing electrical equipment.

DISCONNECT POWER FIRST. Always disconnect machine from power supply **BEFORE** making adjustments, changing tooling, or servicing machine. This prevents an injury risk from unintended startup or contact with live electrical components.

EYE PROTECTION. Always wear ANSI-approved safety glasses or a face shield when operating or observing machinery to reduce the risk of eye injury or blindness from flying particles. Everyday eyeglasses are **NOT** approved safety glasses.



WARNING

WEARING PROPER APPAREL. Do not wear clothing, apparel or jewelry that can become entangled in moving parts. Always tie back or cover long hair. Wear non-slip footwear to avoid accidental slips, which could cause loss of workpiece control.

HAZARDOUS DUST. Dust created while using machinery may cause cancer, birth defects, or long-term respiratory damage. Be aware of dust hazards associated with each workpiece material, and always wear a NIOSH-approved respirator to reduce your risk.

HEARING PROTECTION. Always wear hearing protection when operating or observing loud machinery. Extended exposure to this noise without hearing protection can cause permanent hearing loss.

REMOVE ADJUSTING TOOLS. Tools left on machinery can become dangerous projectiles upon startup. Never leave chuck keys, wrenches, or any other tools on machine. Always verify removal before starting!

USE CORRECT TOOL FOR THE JOB. Only use this tool for its intended purpose—do not force it or an attachment to do a job for which it was not designed. Never make unapproved modifications—modifying tool or using it differently than intended may result in malfunction or mechanical failure that can lead to personal injury or death!

AWKWARD POSITIONS. Keep proper footing and balance at all times when operating machine. Do not overreach! Avoid awkward hand positions that make workpiece control difficult or increase the risk of accidental injury.

CHILDREN & BYSTANDERS. Keep children and bystanders at a safe distance from the work area. Stop using machine if they become a distraction.

GUARDS & COVERS. Guards and covers reduce accidental contact with moving parts or flying debris. Make sure they are properly installed, undamaged, and working correctly.

FORCING MACHINERY. Do not force machine. It will do the job safer and better at the rate for which it was designed.

NEVER STAND ON MACHINE. Serious injury may occur if machine is tipped or if the cutting tool is unintentionally contacted.

STABLE MACHINE. Unexpected movement during operation greatly increases risk of injury or loss of control. Before starting, verify machine is stable and mobile base (if used) is locked.

USE RECOMMENDED ACCESSORIES. Consult this owner's manual or the manufacturer for recommended accessories. Using improper accessories will increase the risk of serious injury.

UNATTENDED OPERATION. To reduce the risk of accidental injury, turn machine **OFF** and ensure all moving parts completely stop before walking away. Never leave machine running while unattended.

MAINTAIN WITH CARE. Follow all maintenance instructions and lubrication schedules to keep machine in good working condition. A machine that is improperly maintained could malfunction, leading to serious personal injury or death.

CHECK DAMAGED PARTS. Regularly inspect machine for any condition that may affect safe operation. Immediately repair or replace damaged or mis-adjusted parts before operating machine.

MAINTAIN POWER CORDS. When disconnecting cord-connected machines from power, grab and pull the plug—NOT the cord. Pulling the cord may damage the wires inside. Do not handle cord/plug with wet hands. Avoid cord damage by keeping it away from heated surfaces, high traffic areas, harsh chemicals, and wet/damp locations.

EXPERIENCING DIFFICULTIES. If at any time you experience difficulties performing the intended operation, stop using the machine! Contact our Technical Support at (570) 546-9663.



Additional Safety for Wood Lathes

WARNING

MAIN INJURY HAZARDS: Death or crushing injury from getting entangled in rotating spindle or workpiece; death, blindness, or broken bones from being struck by a workpiece that breaks apart or comes loose during rotation, turning tool kickback, or flying wood chips. To minimize your risk of these hazards, always heed the following warning information:

INTEGRITY OF STOCK. Verify each workpiece is free of knots, splits, nails, or foreign material to ensure it can safely rotate on spindle without breaking apart or causing turning tool kickback.

WORKPIECE PREPARATION. Before mounting, cut off waste portions with a bandsaw or other tool to ensure workpiece has no large edges to catch turning tool, and it will rotate without dangerous wobbling.

SECURING LOCKS. Verify tool rest, headstock, and tailstock are secure before turning lathe **ON**.

SECURING WORKPIECE. An improperly secured workpiece can fly off spindle with deadly force. Use proven setup techniques and always verify workpiece is well-secured before starting lathe. Only use high-quality fasteners with non-tapered heads for faceplate attachment.

TOOL SUPPORT. An improperly supported tool may be grabbed or ejected. Adjust tool rest approximately 1/4" away from workpiece and 1/8" above workpiece center line to provide proper support for turning tool. Firmly hold turning tool with both hands against tool rest.

TOOL KICKBACK. Occurs when turning tool is ejected from workpiece with great force, striking operator or bystanders. Commonly caused by poor workpiece selection/preparation, improper tool usage, or improper machine setup or tool rest adjustment.

ADJUSTMENT TOOLS. Remove all chuck keys, wrenches, and adjustment tools before turning lathe **ON**. A tool left on the lathe can become a deadly projectile when spindle is started.

SAFE CLEARANCES. Before starting spindle, verify workpiece has adequate clearance by hand-rotating it through its entire range of motion.

EYE/FACE PROTECTION. Always wear a face shield and safety glasses when operating lathe.

PROPER APPAREL. Do not wear gloves, necktie or loose clothing. Keep long hair away from rotating spindle.

SPEED RATES. Select correct spindle speed for workpiece size, type, shape, and condition. Use low speeds when roughing or when turning large, long, or non-concentric workpieces. Allow spindle to reach full speed before turning.

NEW SETUPS. Test each new setup by starting spindle rotation at the lowest speed and standing to the side of the lathe until workpiece reaches full speed and you can verify safe rotation.

ROUGHING. Use correct tool. Take light cuts, use low speeds, and firmly support tool with both hands.

SHARP TOOLS. Only use sharp turning tools—they cut with less resistance than dull tools. Dull turning tools can catch or grab and pull your hands into the rotating workpiece.

STOPPING SPINDLE. Always allow spindle to completely stop on its own. Never put hands or another object on spinning workpiece.

ADJUSTMENTS/MAINTENANCE. Make sure wood lathe is turned **OFF**, disconnected from power, and all moving parts are completely stopped before doing adjustments or maintenance.

MEASURING WORKPIECE. Only measure workpiece after it has stopped. Trying to measure a spinning workpiece increases entanglement risk.

SANDING/POLISHING. To reduce entanglement risk, remove tool rest before sanding. Never completely wrap sandpaper around workpiece.



SECTION 2: POWER SUPPLY

Availability

Before installing the machine, consider the availability and proximity of the required power supply circuit. If an existing circuit does not meet the requirements for this machine, a new circuit must be installed. To minimize the risk of electrocution, fire, or equipment damage, installation work and electrical wiring must be done by an electrician or qualified service personnel in accordance with all applicable codes and standards.

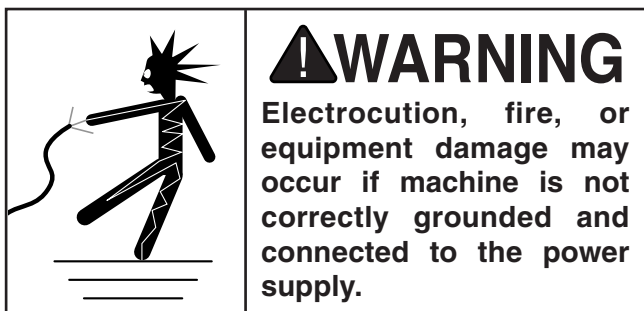

Full-Load Current Rating

The full-load current rating is the amperage a machine draws at 100% of the rated output power. On machines with multiple motors, this is the amperage drawn by the largest motor or sum of all motors and electrical devices that might operate at one time during normal operations.

Model G0657:

Full-Load Current Rating at 110V.....2.5 Amps

Model G0658:

Full-Load Current Rating at 110V.....3.2 Amps

The full-load current is not the maximum amount of amps that the machine will draw. If the machine is overloaded, it will draw additional amps beyond the full-load rating.

If the machine is overloaded for a sufficient length of time, damage, overheating, or fire may result—especially if connected to an undersized circuit. To reduce the risk of these hazards, avoid overloading the machine during operation and make sure it is connected to a power supply circuit that meets the specified circuit requirements.

! WARNING

Serious injury could occur if you connect the machine to power before completing the setup process. DO NOT connect to power until instructed later in this manual.

110V Circuit Requirements

This machine is prewired to operate on a power supply circuit that has a verified ground and meets the following requirements:

Nominal Voltage 110V–120V
Cycle 60 Hz
Phase Single-Phase
Power Supply Circuit 15 Amps
Plug/Receptacle NEMA 5-15

A power supply circuit includes all electrical equipment between the breaker box or fuse panel in the building and the machine. The power supply circuit used for this machine must be sized to safely handle the full-load current drawn from the machine for an extended period of time. (If this machine is connected to a circuit protected by fuses, use a time delay fuse marked D.)

! CAUTION

For your own safety and protection of property, consult an electrician if you are unsure about wiring practices or electrical codes in your area.

Note: *The circuit requirements listed in this manual apply to a dedicated circuit—where only one machine will be running at a time. If this machine will be connected to a shared circuit where multiple machines will be running at the same time, consult a qualified electrician to ensure that the circuit is properly sized for safe operation.*



Grounding & Plug Requirements

This machine **MUST** be grounded. In the event of certain malfunctions or breakdowns, grounding reduces the risk of electric shock by providing a path of least resistance for electric current.

This machine is equipped with a power cord that has an equipment-grounding wire and a grounding plug (similar to the figure below). The plug must only be inserted into a matching receptacle (outlet) that is properly installed and grounded in accordance with all local codes and ordinances.

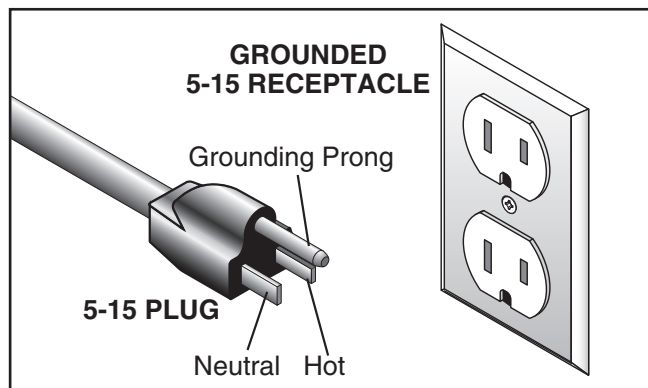

Figure 2. Typical 5-15 plug and receptacle.

⚠ CAUTION

SHOCK HAZARD!

Two-prong outlets do not meet the grounding requirements for this machine. Do not modify or use an adapter on the plug provided—if it will not fit the outlet, have a qualified electrician install the proper outlet with a verified ground.

Improper connection of the equipment-grounding wire can result in a risk of electric shock. The wire with green insulation (with or without yellow stripes) is the equipment-grounding wire. If repair or replacement of the power cord or plug is necessary, do not connect the equipment-grounding wire to a live (current carrying) terminal.

Check with a qualified electrician or service personnel if you do not understand these grounding requirements, or if you are in doubt about whether the tool is properly grounded. If you ever notice that a cord or plug is damaged or worn, disconnect it from power, and immediately replace it with a new one.

Extension Cords

We do not recommend using an extension cord with this machine. If you must use an extension cord, only use it if absolutely necessary and only on a temporary basis.

Extension cords cause voltage drop, which may damage electrical components and shorten motor life. Voltage drop increases as the extension cord size gets longer and the gauge size gets smaller (higher gauge numbers indicate smaller sizes).

Any extension cord used with this machine must contain a ground wire, match the required plug and receptacle, and meet the following requirements:

Minimum Gauge Size14 AWG
Maximum Length (Shorter is Better).....50 ft.



SECTION 3: SETUP

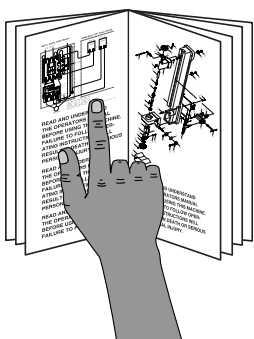

! WARNING
This machine presents serious injury hazards to untrained users. Read through this entire manual to become familiar with the controls and operations before starting the machine!



! WARNING
Wear safety glasses during the entire setup process!



! WARNING
The Model G0657/G0658 is a heavy machine. DO NOT over-exert yourself while unpacking or moving your machine—get assistance.

Unpacking

The Model G0657/G0658 was carefully packed when it left our warehouse. If you discover the machine is damaged after you have signed for delivery, *please immediately call Customer Service at (570) 546-9663 for advice.*

Save the containers and all packing materials for possible inspection by the carrier or its agent. *Otherwise, filing a freight claim can be difficult.*

When you are completely satisfied with the condition of your shipment, inventory the contents.

Inventory

Box Contents: (Figure 3)	Qty
A. Benchtop Lathe (Not Shown)	1
B. Knockout Bar	1
C. Safety Glasses	1
D. Spur Center MT#2	1
E. Live Center MT#2	1
F. Hex Wrenches 2.5, 3, 6mm.....	1 Each

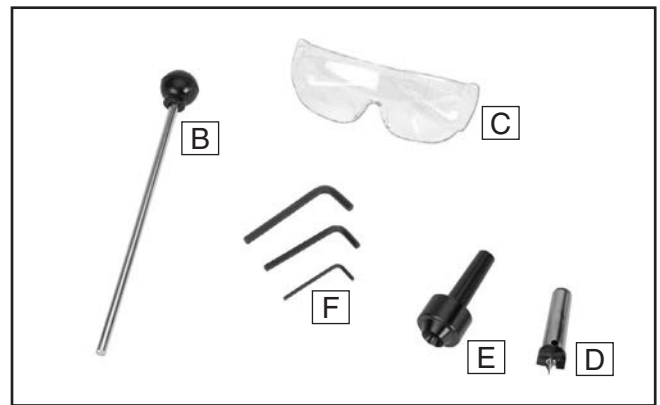

Figure 3. Box contents.

Additional Contents (G0658 only):	Qty
G. Flat Washers 3/8".....	3
H. Lock Handles.....	3
I. Outboard Turning Attachment	1

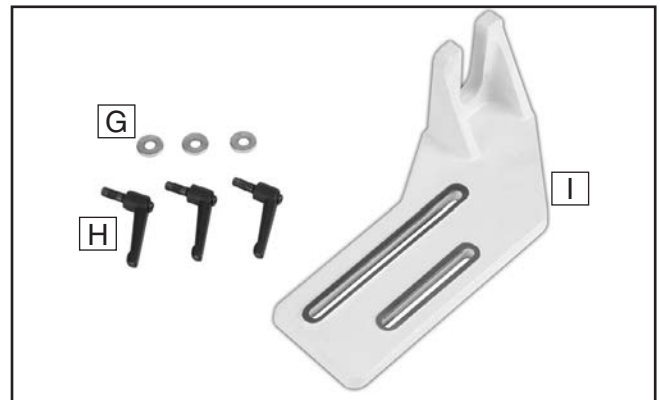

Figure 4. Additional contents (G0658 only).

If any nonproprietary parts are missing (e.g. a nut or a washer), we will gladly replace them, or for the sake of expediency, replacements can be obtained at your local hardware store.



Cleanup

The unpainted surfaces of your machine are coated with a heavy-duty rust preventative that prevents corrosion during shipment and storage. This rust preventative works extremely well, but it will take a little time to clean.

Be patient and do a thorough job cleaning your machine. The time you spend doing this now will give you a better appreciation for the proper care of your machine's unpainted surfaces.

There are many ways to remove this rust preventative, but the following steps work well in a wide variety of situations. Always follow the manufacturer's instructions with any cleaning product you use and make sure you work in a well-ventilated area to minimize exposure to toxic fumes.

Before cleaning, gather the following:

- Disposable rags
- Cleaner/degreaser (WD•40 works well)
- Safety glasses & disposable gloves
- Plastic paint scraper (optional)

Basic steps for removing rust preventative:

1. Put on safety glasses.
2. Coat the rust preventative with a liberal amount of cleaner/degreaser, then let it soak for 5–10 minutes.
3. Wipe off the surfaces. If your cleaner/degreaser is effective, the rust preventative will wipe off easily. If you have a plastic paint scraper, scrape off as much as you can first, then wipe off the rest with the rag.
4. Repeat **Steps 2–3** as necessary until clean, then coat all unpainted surfaces with a quality metal protectant to prevent rust.

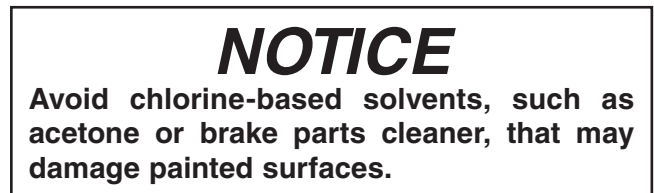
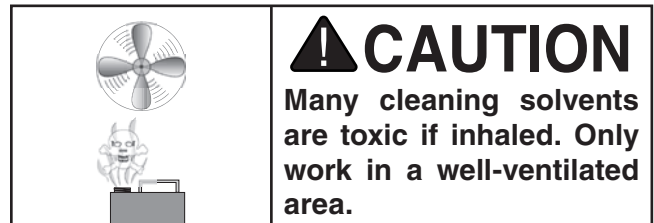
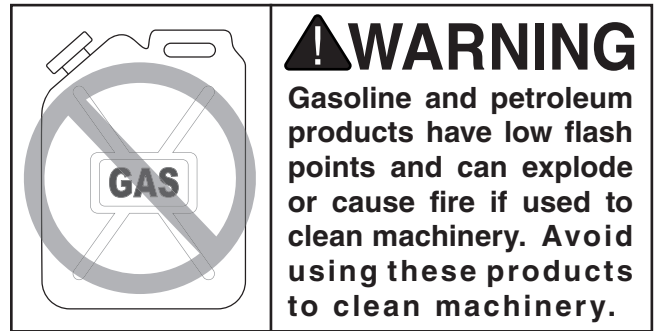

T23692—Orange Power Degreaser

A great product for removing the waxy shipping grease from your machine during clean up.



Figure 5. T23692 Orange Power Degreaser.



Site Considerations

Weight Load

Refer to the **Machine Data Sheet** for the weight of your machine. Make sure that the surface upon which the machine is placed will bear the weight of the machine, additional equipment that may be installed on the machine, and the heaviest workpiece that will be used. Additionally, consider the weight of the operator and any dynamic loading that may occur when operating the machine.

Space Allocation

Consider the largest size of workpiece that will be processed through this machine and provide enough space around the machine for adequate operator material handling or the installation of auxiliary equipment. With permanent installations, leave enough space around the machine to open or remove doors/covers as required by the maintenance and service described in this manual. **See below for required space allocation.**



Physical Environment

The physical environment where the machine is operated is important for safe operation and longevity of machine components. For best results, operate this machine in a dry environment that is free from excessive moisture, hazardous chemicals, airborne abrasives, or extreme conditions. Extreme conditions for this type of machinery are generally those where the ambient temperature range exceeds 41°–104°F; the relative humidity range exceeds 20–95% (non-condensing); or the environment is subject to vibration, shocks, or bumps.

Electrical Installation

Place this machine near an existing power source. Make sure all power cords are protected from traffic, material handling, moisture, chemicals, or other hazards. Make sure to leave access to a means of disconnecting the power source or engaging a lockout/tagout device, if required.

Lighting

Lighting around the machine must be adequate enough that operations can be performed safely. Shadows, glare, or strobe effects that may distract or impede the operator must be eliminated.

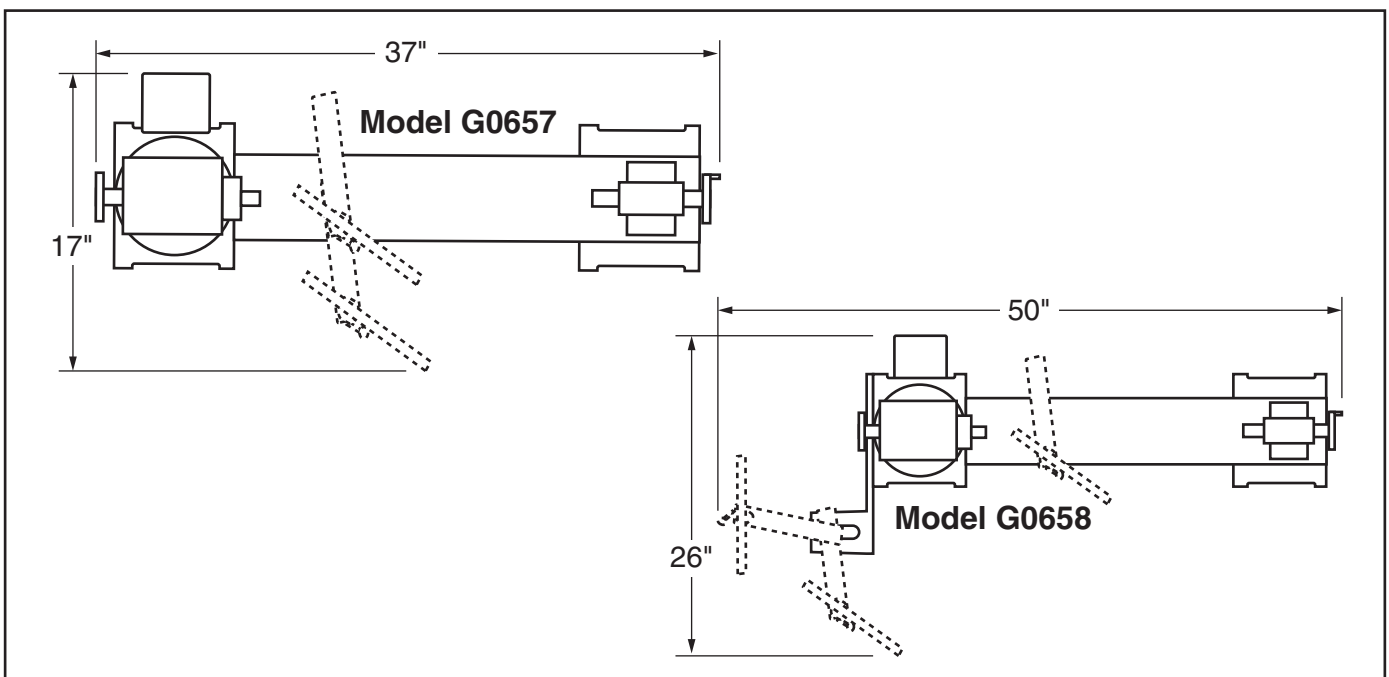

Figure 6. Minimum working clearances.



Mounting

Once you have confirmed that your machine is running properly, you may decide to mount it to a workbench. Simply remove the adjustable feet and mount it through the holes in the base.

The strongest mounting option is a "Through Mount" where holes are drilled all the way through the workbench, and hex bolts, washers, and hex nuts are used to secure the drill press to the workbench.

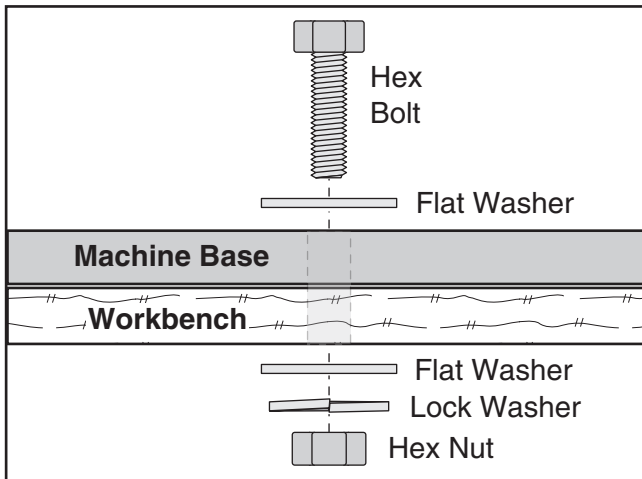

Figure 7. Example of a through mount setup.

Another option for mounting is a "Direct Mount" where the machine is simply secured to the workbench with a lag screw.

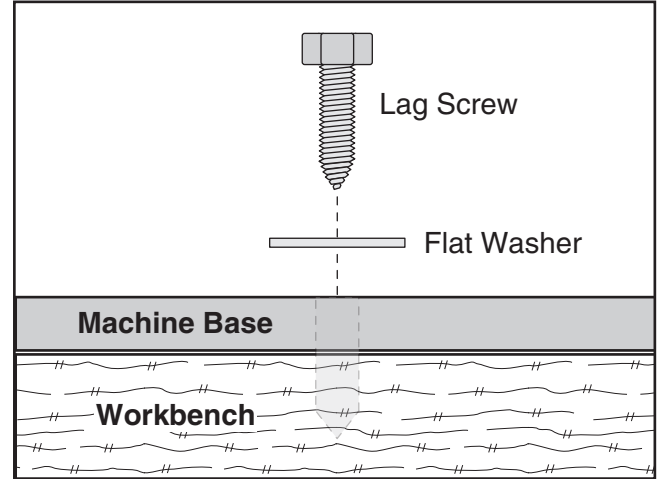

Figure 8. Example of a direct mount setup.

Whichever method you choose, it is crucial that the workbench is perfectly flat. Mounting the lathe to a surface that is not flat may cause the lathe bed to warp. Make sure all four corners are sitting firmly on the workbench and, if necessary, use shims to level the lathe and prior to mounting.

Do not overtighten the mounting fasteners as this may crack the cast iron feet.



Assembly

Before use, the tool rest must be moved out of its shipping position and centers must be inserted. For the Model G0658, installing the outboard turning attachment is an optional step.

To prepare the lathe:

1. Loosen the release lever and rotate the tool rest base away from the lathe bed.
2. Loosen the tool rest lock handle and rotate the tool rest so that it is positioned parallel to the lathe bed (**Figure 9**).

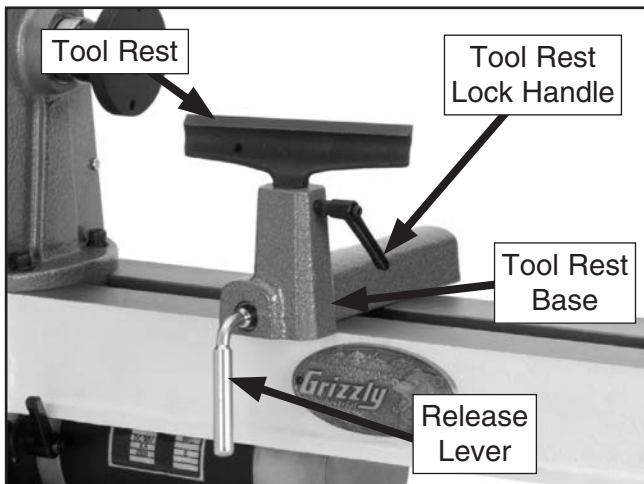

Figure 9. Tool rest positioned.

3. Tighten the tool rest lock handle.
4. To insert the centers, refer to **Installing/Removing Spur Center** and **Installing/Removing Live Center** on **Page 23**.

To install the outboard turning attachment (Model G0658 only):

1. Insert one of the lock handles through the upper slot in the outboard turning attachment, as shown in **Figure 10**.

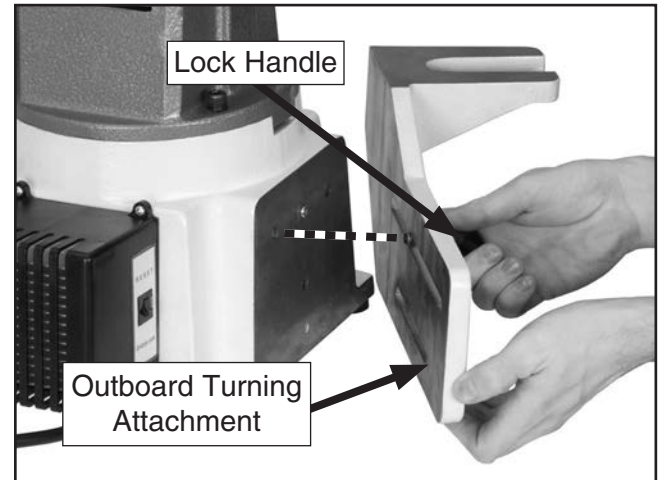

Figure 10. Positioning Handle

2. Line up the threaded portion of the handle with one of the holes in the lathe base, then thread the handle into the hole. Do not yet fully tighten the handle.
3. Tilt the outboard turning attachment as necessary so the slots line up with the other two holes in the lathe base, then thread in the other two handles.
4. Firmly tighten the handles to secure the outboard turning attachment in position (**Figure 11**).

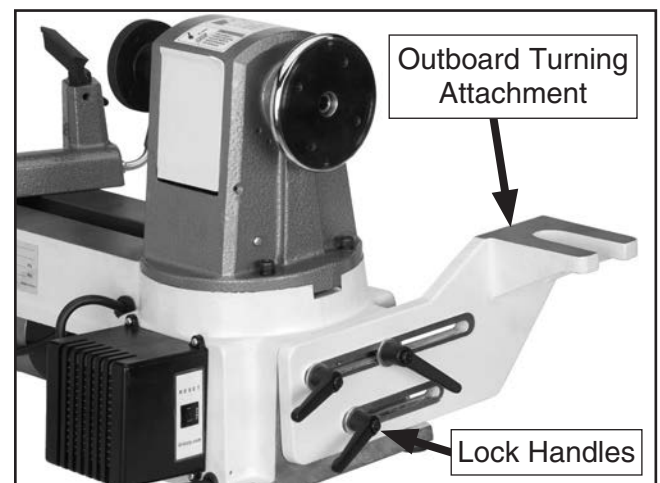

Figure 11. Outboard Turning Attachment



Test Run

Once the setup is complete, test run your machine to make sure it runs properly and is ready for regular operation.

The test run consists of verifying the following:
1) The motor powers up and runs correctly, and
2) the safety disabling mechanism on the switch works correctly.

If, during the test run, you cannot easily locate the source of an unusual noise or vibration, stop using the machine immediately, then review **Troubleshooting** on **Page 33**.

If you still cannot remedy a problem, contact our Tech Support at (570) 546-9663 for assistance.

To test run the machine:

1. Make sure you have read the safety instructions at the beginning of the manual and that the machine is setup properly.
2. Make sure all tools and objects used during setup are cleared away from the machine.
3. Connect the machine to the power source.
4. Verify that the machine is operating correctly by turning the machine **ON**.

—When operating correctly, the machine runs smoothly with little or no vibration or rubbing noises.

—Investigate and correct strange or unusual noises or vibrations before operating the machine further. Always disconnect the machine from power when investigating or correcting potential problems.

5. Turn the machine **OFF**.
6. Remove the switch disabling key, as shown in **Figure 12**.

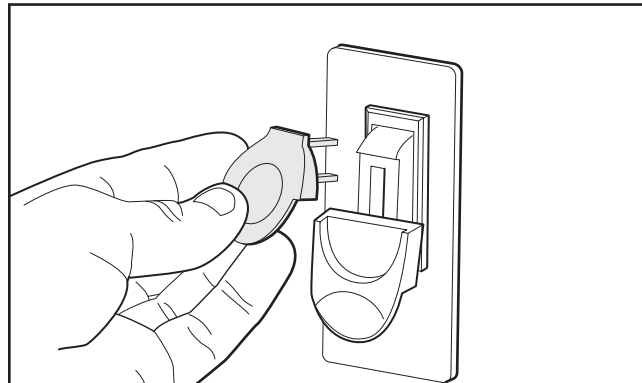

Figure 12. Removing switch key from paddle switch.

7. Try to turn the start the machine with the paddle switch.
 - If the machine does not start, the switch disabling feature is working as designed.
 - If the machine starts, immediately stop the machine. The switch disabling feature is not working correctly. This safety feature must work properly before proceeding with regular operations. Call Tech Support for help.



SECTION 4: OPERATIONS

!WARNING

Damage to your eyes, lungs, and ears could result from using this machine without proper protective gear. Always wear a face shield, respirator, and hearing protection when operating this machine.

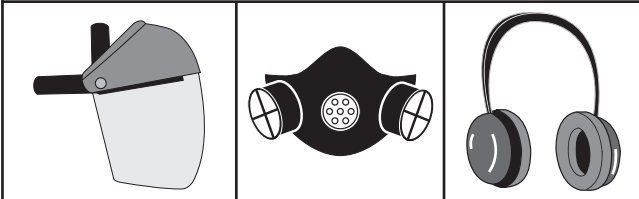

!WARNING

Loose hair and clothing could get caught in machinery and cause serious personal injury. Keep loose clothing and long hair away from moving machinery.



NOTICE

If you have never used this type of machine or equipment before, WE STRONGLY RECOMMEND that you read books, trade magazines, or get formal training before beginning any projects. Regardless of the content in this section, Grizzly Industrial will not be held liable for accidents caused by lack of training.

Disabling Switch

The switch can be disabled by removing the key, as shown below. Disabling the switch in this manner can prevent unauthorized operation of the machine, which is important if it is not kept inside an access-restricted building or in a location where children may be present.

IMPORTANT: *Disabling the switch only restricts its function. It is not a substitute for disconnecting machine from power when adjusting or servicing.*

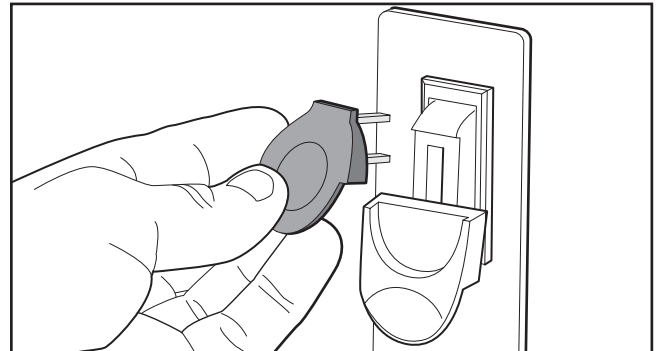

Figure 13. Disabling switch by removing key.

!WARNING

Children or untrained people can be seriously injured by this machine. This risk increases with unsupervised operation. To help prevent unsupervised operation, always disable switch before leaving machine unattended. Make sure to place key in a well-hidden or secure location!



Basic Controls

Use the descriptions and figures below to become familiar with the basic controls of your lathe.

Lathe ON/OFF Switch: Turns power ON/OFF to the lathe motor, which rotates the spindle.

Speed Adjust Knob: Adjusts the speed of the spindle within the current belt position speed range.

RPM Display: Displays the spindle speed in revolutions per minute (RPM).

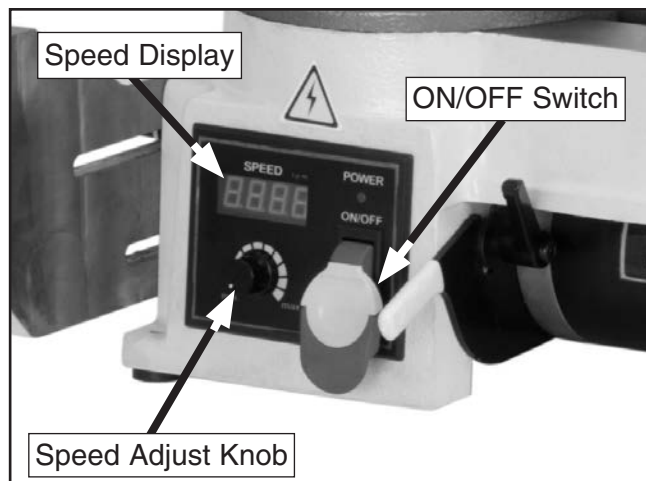

Figure 14. Control Panel.

Tool Rest: Provides a stable resting position for turning tools.

Tool Rest Lock Handle: Locks the tool rest in position relative to the tool rest base.

Base Release Lever: Releases the tool rest base and allows it to be repositioned along the lathe bed.

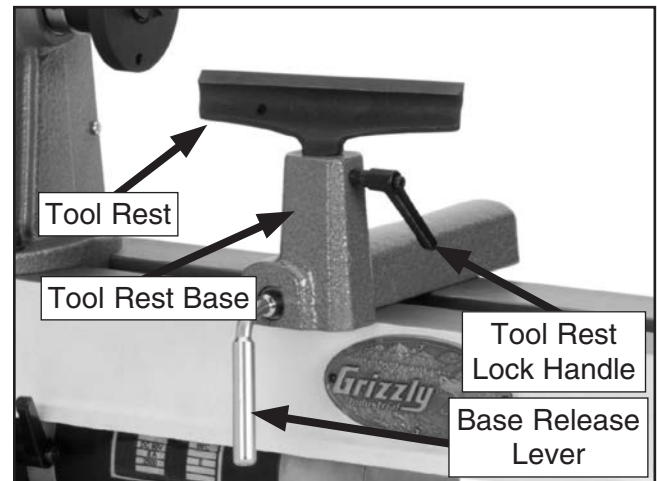

Figure 15. Tool Rest Controls.

Quill Handwheel: Moves the quill in and out to allow the clamping or releasing of the workpiece.

Quill Lock Handle: Locks the quill in place to prevent loosening during operation of the lathe.

Tailstock Release Lever: Releases the tailstock to allow quick position adjustments.

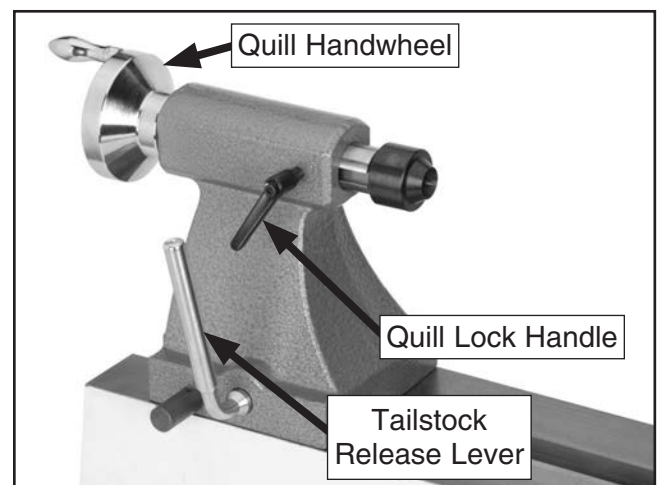

Figure 16. Tailstock Controls.



Changing Speed Ranges

The variable speed motors on the Model G0657 and G0658 allow the spindle speed to vary within three separate ranges. For greater speed variations, the belt in the headstock can be repositioned. A label on the top of the headstock illustrates the belt positions and their speeds.

To change speeds:

1. DISCONNECT LATHE FROM POWER!
2. Loosen the belt tension screw handle (**Figure 17**). Be sure the belt tension lever moves freely to release tension from the belt.

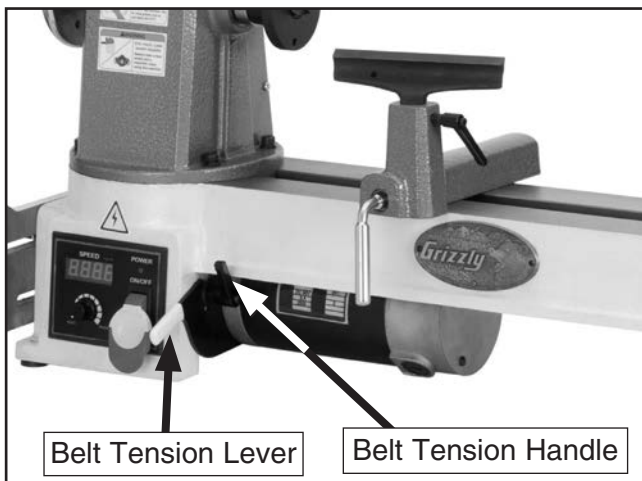

Figure 17. Belt tension lever.

3. Open the rear access covers (**Figure 18**).

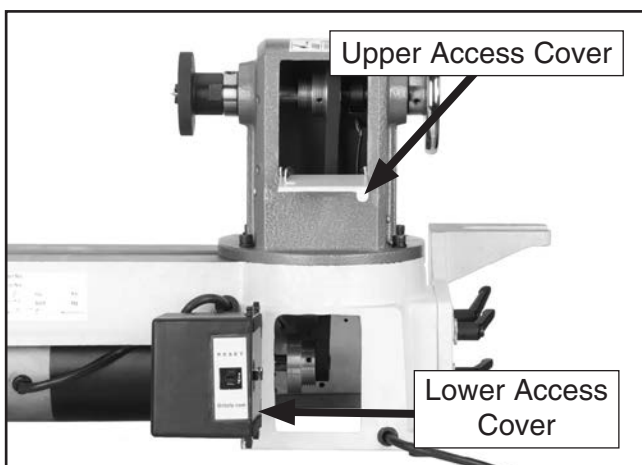

Figure 18. Side and rear access covers.

4. Locate the desired speed on the speed chart on the rear of the lathe bed, and move the belt to the necessary grooves on the motor and spindle pulleys.

For Example: As indicated in the speed chart, on the **G0657**, belt position **B** creates an RPM range of **600-1800** (**Figure 19**).

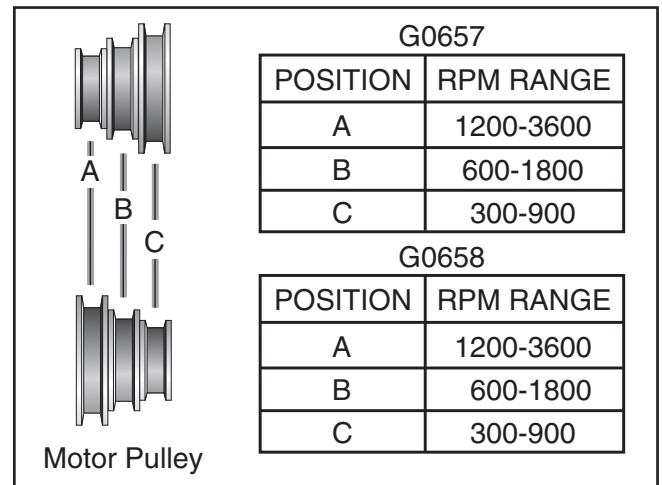

Figure 19. G0658 Spindle speeds.

5. Move the belt tension lever down, adjusting tension so that when the belt is pressed with moderate force, $\frac{1}{2}$ " of belt deflection is measured as shown in **Figure 20**, then tighten belt tension lever screw.

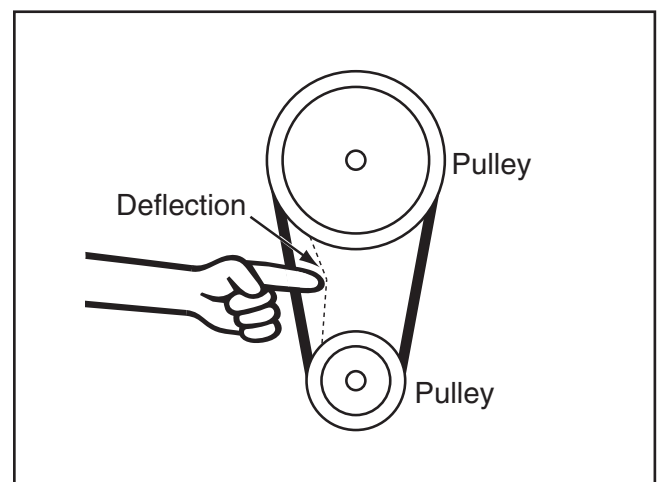

Figure 20. Belt deflection.

6. Close the rear covers.



Adjusting Tailstock

The tailstock is equipped with a cam-action clamping system to secure it to the lathe bed. When the lever is engaged, a locking plate lifts and secures the tailstock to the bed.

To position the tailstock along the bed:

1. Loosen the release lever and move the tailstock to the desired position (**Figure 21**).

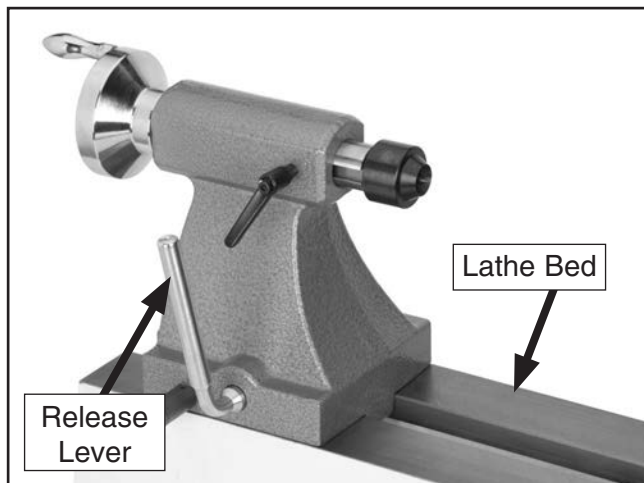

Figure 21. Tailstock controls.

2. Re-engage the release lever.

—If the release lever will not lock or release the tailstock (either too loose or too tight), loosen or tighten the tailstock mounting nut (located on the underside of the tailstock) in small increments as needed to achieve the proper clamping pressure (**Figure 22**).

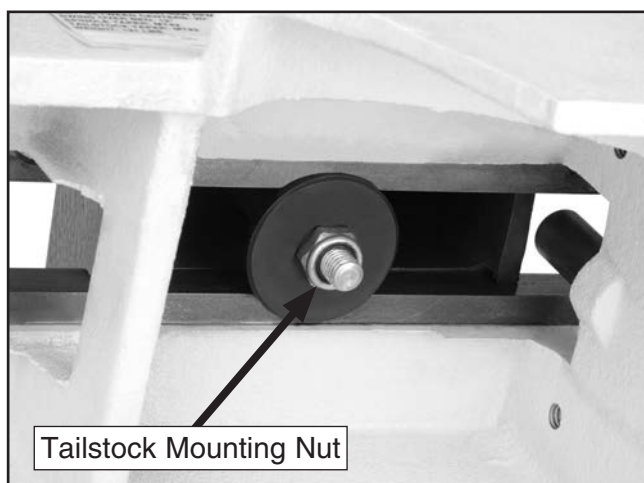

Figure 22. Release lever adjustment.

Adjusting Tool Rest

The tool rest base is equipped with a cam-action clamping system to secure it to the lathe bed. When the lever is engaged, a locking plate lifts up and secures the tool rest base to the bed.

To position the tool rest base along the bed:

1. Loosen the release lever and slide the tool rest base along the bed (**Figure 23**).

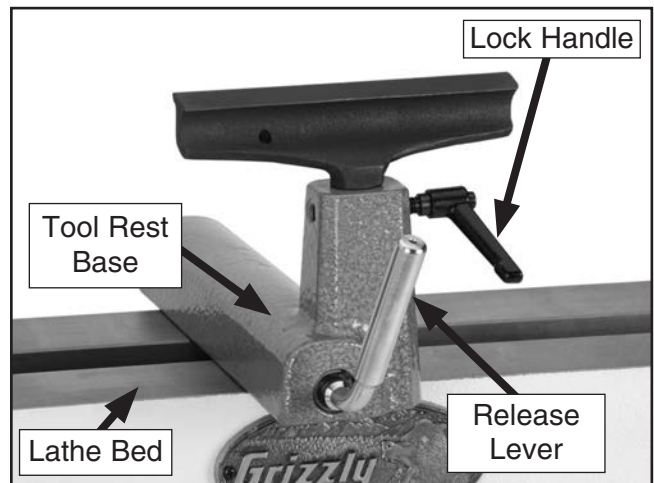

Figure 23. Tool rest controls.

2. Re-engage the release lever to lock the tool rest base in place.

—If the release lever will not lock or release (either too loose or too tight), then loosen or tighten the tool rest base mounting nut (located on the underside of the tool rest base) in small increments as needed to achieve the proper clamping pressure. Refer to **Figure 22**.

To adjust the tool rest:

1. Loosen the lock handle (**Figure 23**) and adjust the tool rest vertically and/or swivel it as needed, then tighten the lock handle.



Installing/Removing Spur Center

The spur center installs into the headstock spindle with a taper fit.

To install the spur center:

1. DISCONNECT LATHE FROM POWER!
2. Insert the tapered end of the center into the spindle, and push it in quickly and firmly (**Figure 24**).

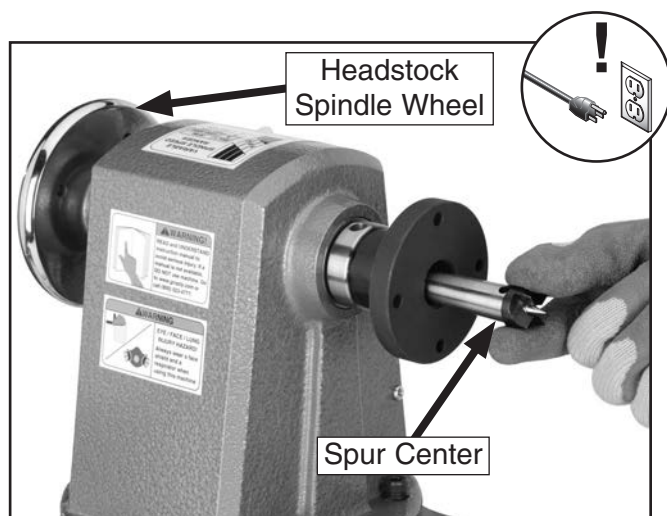

Figure 24. Inserting spur center into spindle.

3. Check that the center is securely installed by giving it a quick tug. (A properly installed center will not pull out by hand.)

To remove the spur center:

1. DISCONNECT LATHE FROM POWER!
2. Insert the knockout rod into the outboard end of the spindle. Use a shop rag or wear a glove to catch the center and gently tap the rod handle until the spur center is freed from the spindle (**Figure 25**).

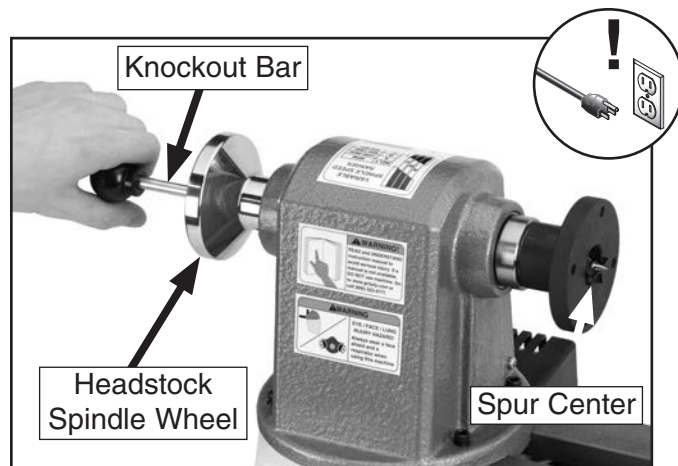

Figure 25. Removing spur center.

Installing/Removing Live Center

To install the live center:

1. Loosen the quill lock handle (if locked) approximately half a turn counterclockwise.
2. Rotate the quill handwheel clockwise until the quill protrudes about 3/4".
3. Insert the live center, as shown in **Figure 26**, and push firmly.

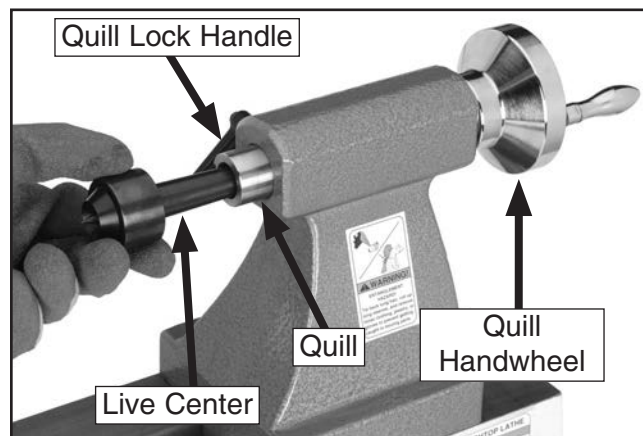

Figure 26. Live center installed in tailstock.

4. Tighten the quill lock handle.



To remove the live center:

1. Loosen the quill lock handle (if locked) approximately half a turn counterclockwise.
2. Turn the quill handwheel counterclockwise until the tailstock quill bottoms out, causing the live center to be forced out of the quill.

⚠️ WARNING

The tailstock quill lock handle must always be locked down while the lathe is in use. The workpiece can be thrown from the lathe if this step is not observed. Also, the tailstock quill should not protrude from the tailstock housing more than 2" or the quill will not be supported enough. Failure to follow these warnings may result in personal injury.

Removing/Installing Faceplate

These instructions cover removing and installing the faceplate. To mount a workpiece to your faceplate, refer to **Faceplate Turning** on **Page 28**.

To remove the faceplate:

1. DISCONNECT LATHE FROM POWER!
2. Hold the headstock spindle wheel securely while turning the faceplate counterclockwise until it is removed. If the spur center is installed, it will be removed during this process.

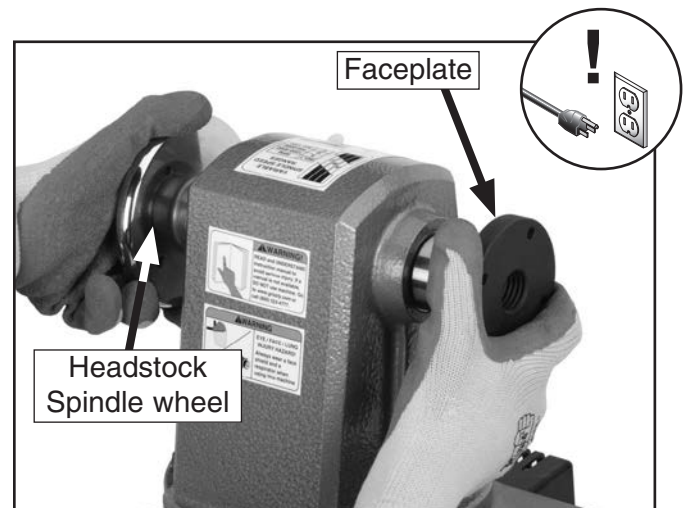

Figure 27. Removing faceplate.

To install the faceplate:

1. DISCONNECT LATHE FROM POWER!
2. Thread faceplate onto spindle shaft until it is secure against the shoulder on the spindle shaft.



Selecting Turning Tools

Lathe tools come in a variety of shapes and sizes and usually fall into five major categories.

- **Gouges**—Mainly used for rough cutting, detail cutting, and cove profiles. The rough gouge is a hollow, double-ground tool with a round nose, and the detail gouge is a hollow, double-ground tool with either a round or pointed nose. **Figure 28** shows an example of a gouge.

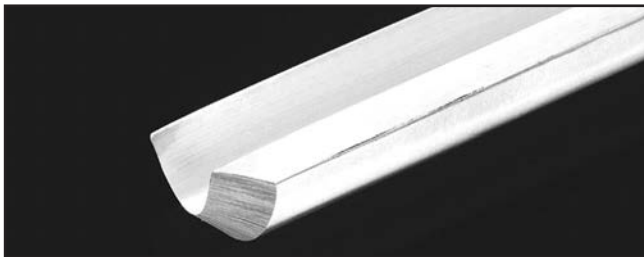

Figure 28. Gouge.

- **Skew Chisel**—A very versatile tool that can be used for planing, squaring, V-cutting, beading, and parting off. The skew chisel is flat, double-ground with one side higher than the other (usually at an angle of 20-40°). **Figure 29** shows an example of a skew chisel.



Figure 29. Skew chisel.

- **Scrapers**—Mainly used where access for other tools is limited, such as hollowing operations. This is a flat, double-ground tool that comes in a variety of profiles (Round Nose, Spear Point, Square Nose, etc.) to match many different contours. **Figure 30** shows an example of a round nose scraper.



Figure 30. Round nose scraper.

- **Parting Tools**—Used for sizing and cutting off work. This is a flat tool with a sharp pointed nose that may be single- or double-ground. **Figure 31** shows an example of a parting tool.



Figure 31. Parting tool.

- **Specialty Tools**—These are the unique, special function tools to aid in hollowing, bowl making, cutting profiles, etc. The Swan Neck Hollowing Tool shown on **Page 30** is a good example of a specialty tool.



Outboard Turning (G0658 Only)

The Model G0658 is equipped with a detachable outboard turning attachment. This provides additional clearance for a greater variety of turning tasks.

See **Setup** on **Page 13** for instructions on installing the outboard turning attachment.

To mount a workpiece to the spindle handwheel for outboard turning, see **Faceplate Turning** on **Page 28**. The method for attaching a workpiece to the spindle is the same for both turning methods.

To place the tool rest on the outboard turning attachment:

1. DISCONNECT LATHE FROM POWER!
2. Prepare the outboard turning attachment by thoroughly cleaning it to remove debris or buildup.
3. Release the tool rest base release lever so the tool rest moves freely, then position the tool rest so the entire base sits on the lathe bed. This will prevent the tool rest from falling when the lock nut is removed (**Figure 32**).

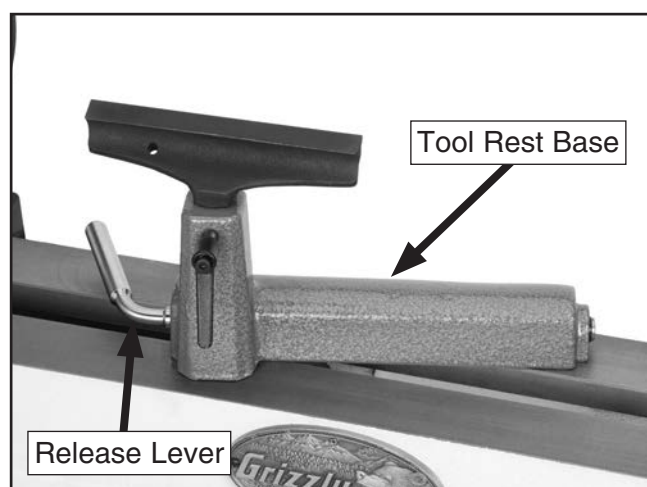

Figure 32. Safe tool rest position.

4. Loosen and remove the lock nut and clamp washer from beneath the tool rest base (**Figure 33**).

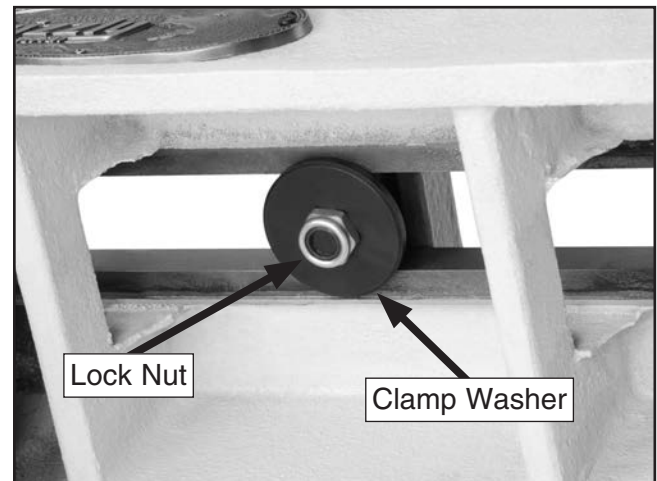

Figure 33. Lock nut and clamp washer location (viewed from beneath).

5. Lift the tool rest from the lathe bed and reposition it on the outboard turning attachment so that the clamp shaft protrudes through the gap in the outboard turning attachment (**Figure 34**).

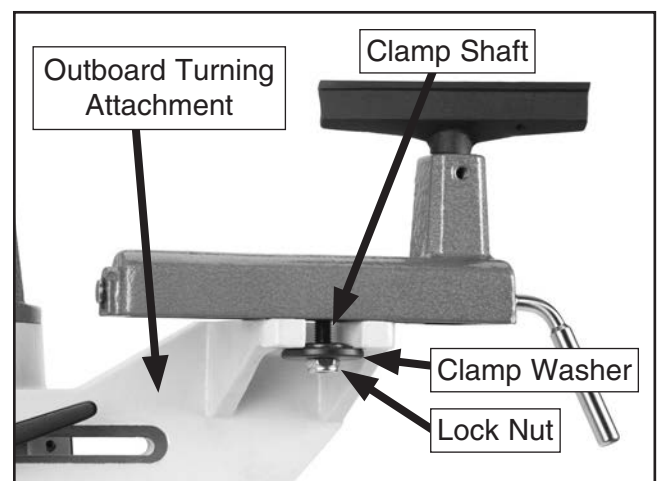

Figure 34. Outboard mounting.

6. Replace the clamp washer and lock located on the clamp shaft. Tighten the lock nut so the release handle will clamp the tool rest securely when locked but still allow easy movement when released.



Spindle Turning

Spindle turning (**Figure 35**) is the operation performed when a workpiece is mounted between the headstock and the tailstock.

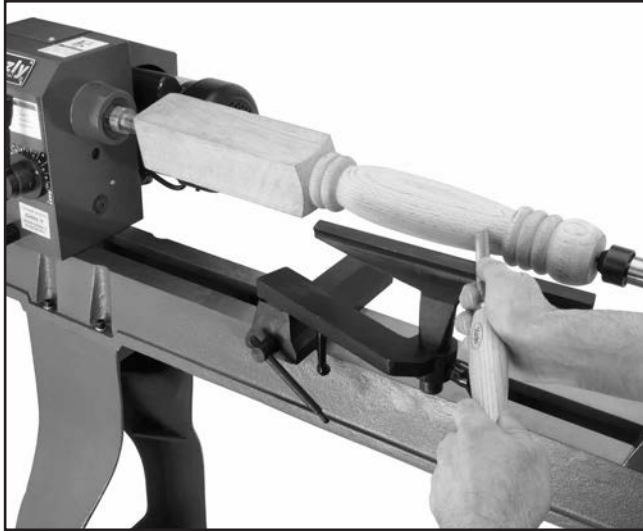

Figure 35. Typical spindle turning operation.

To set up a spindle turning operation:

1. Mark both ends of your workpiece by drawing diagonal lines from corner to corner. The intersection point of these lines will show you the center of your workpiece. See **Figure 36** for details.

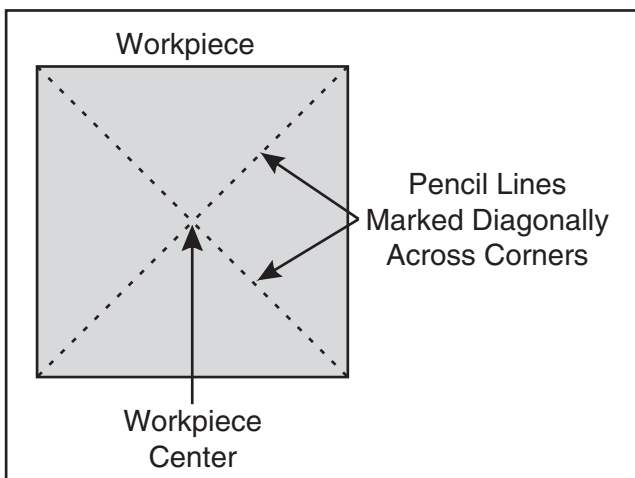

Figure 36. Workpiece marked diagonally from corner to corner to determine the center.

2. Using a wood mallet, tap the point of the spur center into the center of the workpiece, so that it leaves a center mark, then remove the spur center.
3. Using a $\frac{1}{8}$ " drill bit, drill a $\frac{3}{16}$ " deep hole at the center mark.
4. Cut the corners off your workpiece if it is over 2" x 2" to make turning safer and easier.
5. Drive the spur center into the center of the workpiece with a wood mallet to embed it at least $\frac{1}{4}$ ", as shown in **Figure 37**.

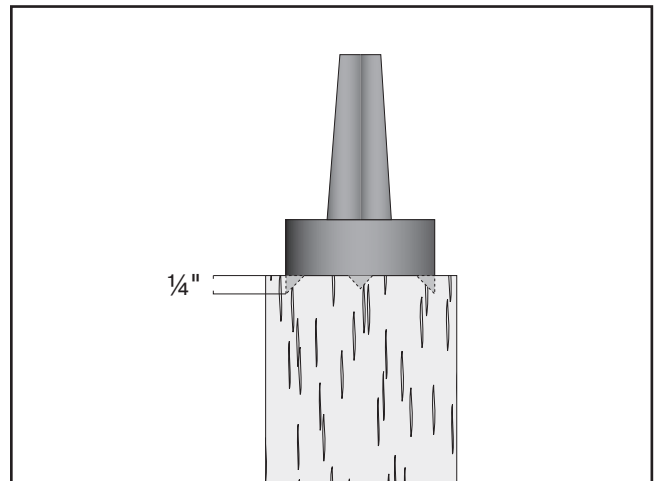

Figure 37. Spur center properly embedded.

6. With the workpiece still attached, insert the spur center into the headstock spindle.
7. With the live center installed in the tailstock, slide the tailstock toward the workpiece until the live center touches the workpiece center-point, then lock the tailstock in this position.
8. Use the quill handwheel to push the live center into the workpiece at least $\frac{1}{4}$ ".

WARNING

Do not press the workpiece too firmly with the tailstock or the bearings will bind and overheat. Likewise, do not leave it too loose or the workpiece will spin off the lathe. Use good judgement. Serious personal injury could result if care is not taken.



- Position the tool rest approximately $\frac{1}{4}$ " away from the workpiece and approximately $\frac{1}{8}$ " above the center line, as shown in **Figure 38**.

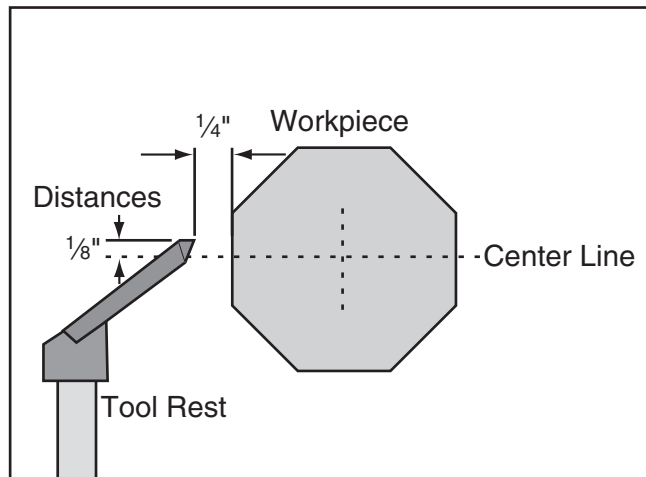

Figure 38. Tool rest position.

- Test the setup by hand-turning the workpiece to make sure there is enough clearance all the way around before starting.

Spindle Turning Tips:

- When turning the lathe **ON**, stand to the side of the spinning direction until the lathe reaches full speed and you can verify that the lathe will not throw the workpiece.
 - Use the slowest spindle speed when rough cutting.
 - Select the right speed for the size of workpiece you are turning. Use slower speeds for large workpieces (4" diameter and over); use the middle range speeds for medium sized workpieces (2" to 4" diameter); and use faster speeds for small sized workpieces (under 2" in diameter).
 - Make sure the turning tool is against the tool rest the ENTIRE time that the turning tool is in contact with the workpiece.
 - Learn the correct techniques for each tool you will use. If you are unsure, read books or magazines about lathe techniques and seek training from experienced users.
- Turn the lathe **OFF** immediately if the workpiece vibrates excessively. Check to make sure the workpiece is centered and balanced. Remove the workpiece and trim excess waste off corners with a bandsaw or table saw to reduce vibration. Make sure the workpiece is securely attached in the setup.

Faceplate Turning

Faceplate turning (**Figure 39**) is when a workpiece is mounted to the faceplate, which is mounted to the headstock spindle. This type of turning is usually done with open-faced workpieces like bowls.

If screws cannot be placed in the workpiece, then a backing block can be glued to the workpiece and attached to the faceplate with screws.



Figure 39. Typical faceplate turning operation.

To mount your workpiece to the faceplate:

- Find the center of your workpiece in the same manner as when spindle turning.
- Cut off the corners of the workpiece.
- Center the faceplate on the workpiece and attach it through the faceplate holes with non-tapered head wood screws as shown in **Figure 40**.
- Thread the faceplate onto the headstock spindle and tighten securely.



Sanding/Finishing

NOTICE: Only use tap screws or wood screws with non-tapered heads (**Figure 40**) to attach the faceplate to the workpiece. Do NOT use drywall screws or screws with tapered heads because these can split the faceplate, or the screws may snap off during operation.

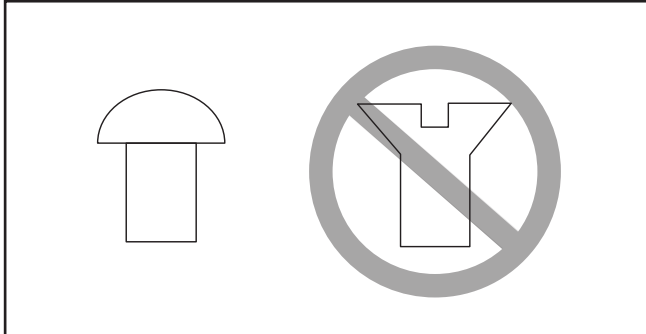

Figure 40. Correct and incorrect screw types for mounting faceplate to workpiece.

To mount your workpiece to a backing block:

1. Make the backing block (**Figure 41**) from a piece of scrap wood that is flat on both sides.

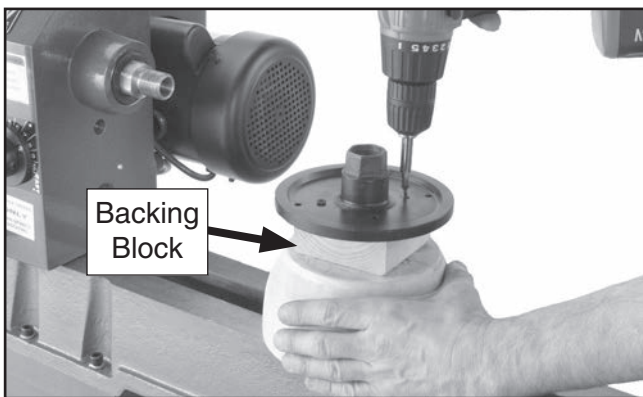

Figure 41. Example of mounting faceplate to a backing block.

2. Locate and mark the center of both the workpiece and the backing block.
3. Drill a 1/4" diameter hole through the center of the backing block.
4. Glue the center of the backing block to the center of the workpiece (look through the drilled hole to line up centers), clamp the backing block to the workpiece, and wait for the glue to cure according to the manufacturer's recommendation.

After turning, the workpiece can be sanded, as shown in **Figure 42**, and finished (in the same manner) before removing it from the lathe.

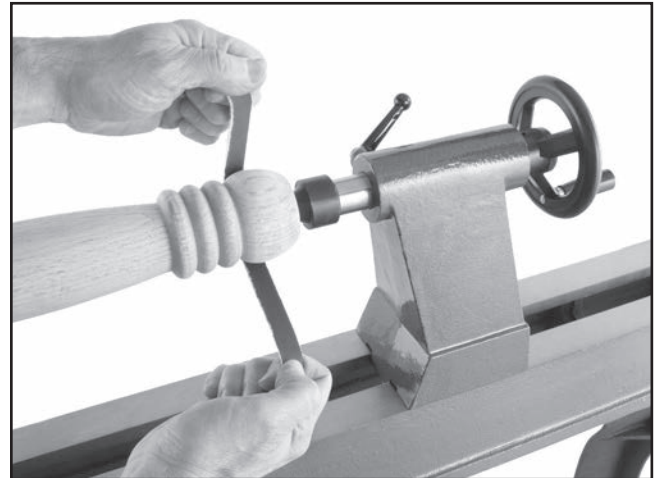
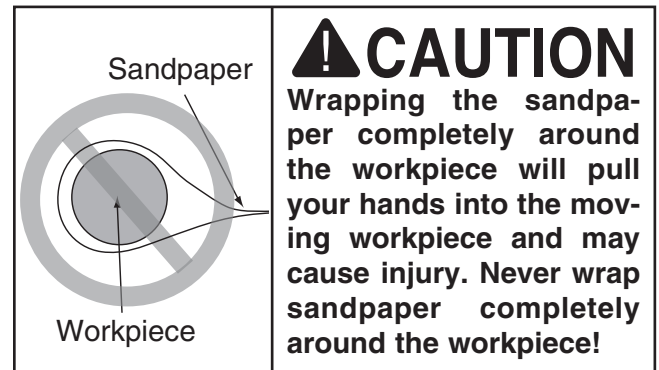

Figure 42. Typical sanding operation.



Whenever sanding or finishing, move the tool rest holder out of the way to increase personal safety and gain adequate working room.



SECTION 5: ACCESSORIES

! WARNING

Installing unapproved accessories may cause machine to malfunction, resulting in serious personal injury or machine damage. To reduce this risk, only install accessories recommended for this machine by Grizzly.

NOTICE

Refer to our website or latest catalog for additional recommended accessories.

D1090—3-Jaw Chuck

A "must have" for the serious wood turner. This 3-jaw chuck is a self-centering style chuck used mostly for round work. All three jaws tighten together at the same time. Jaws are reversible for expanded work holding capacity. *Threaded insert required for mounting!*



Figure 43. Model G1090 3-Jaw Chuck.

G1098—1" x 8 TPI RH Threaded Insert.

This threaded insert is required to mount a 3- or 4-jaw chuck to your wood lathe.

D1089—4-Jaw Chuck

Another "must have" for the serious wood turner. This 4-jaw chuck is an independent type chuck that is used for square and odd-shaped pieces. Each jaw tightens individually and can be turned around to hold larger dimension workpieces. *Threaded insert required for mounting!*



Figure 44. Model D1089 4-Jaw Chuck.

H6542—Robert Sorby HSS 8-PC Turning Set

G1676—Drill Chuck Arbor MT#2 x JT#3

H6204—Precision Drill Chuck $\frac{1}{32}$ "– $\frac{5}{8}$ " x JT#3

H3102, H3103, H3104—Gouge Slipstones

H1064—6-PC Deluxe HSS Lathe Chisel Set

G9863—8-PC HSS Lathe Chisel Set

H0507—20" Swan Neck Hollowing Tool

H0508—24" Swan Neck Hollowing Tool



Figure 45. Model H6542 Robert Sorby 8-PC Set.

order online at www.grizzly.com or call 1-800-523-4777



D3640—Tool Table Plus

The new Tool Table Plus was designed in response to customer requests for a slightly wider and taller table to accommodate small planers, wood lathes, sanders and a variety of other bench-top machines.



Figure 46. Model D3640 Tool Table Plus.

G8784—4-Jaw Chuck for Round Pieces

Perfect for bowl turning, the jaws of this chuck grip round stock as well as expand within a recess turned in the back of the workpiece. Twist adjustment moves jaws concentrically from 2" to 2¾" O.D. Chuck wrenches included.



Figure 47. Model G8784 4-Jaw Chuck for Round Pieces.

H1408—The Pen Turning Manual

This manual gives you the "hows" and "whys" of pen making. Included are more than 120 illustration depicting virtually every model of pen and project kit on the market today. The author of this book got his start making pens for the craft show circuit. 104 pages, illustrated.

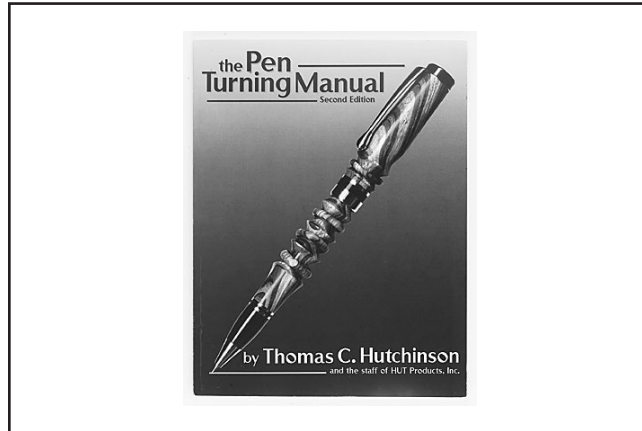

Figure 48. Model H1408 The Pen Turing Manual.

H9080—Robert Sorby Micro Turning Tool Set

These Micro Turning tools were specifically designed for the pen turner. Each has a 6¼" handle length with an overall length of 10". Includes 5/16" rough gouge, 1/16" parting tool, 1/2" Spindlemaster.

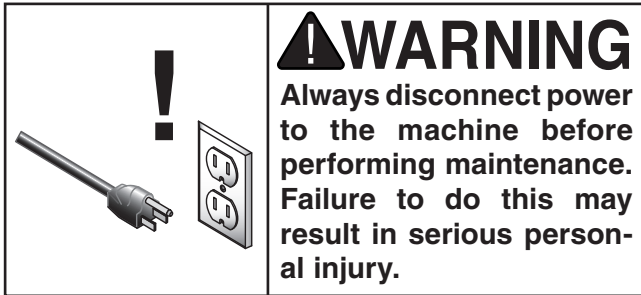

Figure 49. Model H9080 Micro Turning Tool Set.

order online at www.grizzly.com or call 1-800-523-4777



SECTION 6: MAINTENANCE



Schedule

For optimum performance from your machine, follow this maintenance schedule and refer to any specific instructions given in this section.

Daily Check:

- Loose mounting bolts.
- Worn or damaged wires.
- Worn switch
- Any other unsafe condition.

Monthly Check:

- Belt tension, damage, or wear.
- Clean/vacuum dust buildup off of motor.

Cleaning

Cleaning the Model G0657/G0658 is relatively easy. Vacuum excess wood chips and sawdust, and wipe off the remaining dust with a dry cloth. If any resin has built up, use a resin dissolving cleaner to remove it. Treat all unpainted cast iron and steel with a non-staining lubricant after cleaning.

Unpainted Cast Iron

Protect the unpainted cast iron surfaces on the lathe by wiping them clean after every use—this ensures moisture from wood dust does not remain on bare metal surfaces.

Keep the bed rust-free with regular applications of products like G96® Gun Treatment, SLIPIT®, or Boeshield® T-9.

Lubrication

Lubricate the locations shown in **Figure 50** with light machine oil or G96® Gun Treatment.

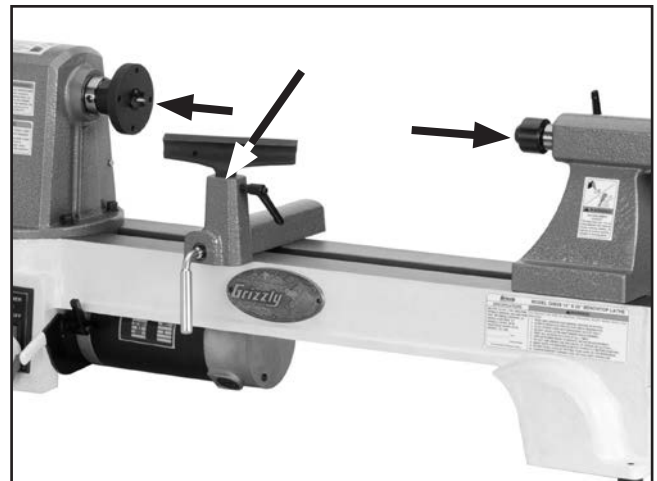

Figure 50. Lubrication locations.



SECTION 7: SERVICE

Review the troubleshooting and procedures in this section to fix or adjust your machine if a problem develops. If you need replacement parts or you are unsure of your repair skills, then feel free to call our Technical Support at (570) 546-9663.

Troubleshooting

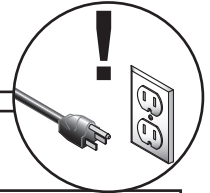

Motor & Electrical

Symptom	Possible Cause	Possible Solution
Machine does not start or a breaker trips.	<ol style="list-style-type: none"> 1. Plug/receptacle is at fault or wired incorrectly. 2. Power supply is at fault/switched OFF. 3. Lockout key is at fault. 4. Motor ON button or ON/OFF switch is at fault. 5. Wiring is at fault. 6. Motor brushes are worn. 7. Motor is at fault. 	<ol style="list-style-type: none"> 1. Test for good contacts; correct the wiring. 2. Ensure hot lines have correct voltage on all legs and main power supply is switched ON. 3. Install/replace lockout key; replace switch. 4. Replace faulty ON button or ON/OFF switch. 5. Check for broken wires or disconnected/corroded connections, and repair/replace as necessary. 6. Replace brushes. 7. Test/repair/replace.
Machine stalls or is Overloaded.	<ol style="list-style-type: none"> 1. Too much tool pressure. 2. Plug/receptacle is at fault. 3. Motor bearings are at fault. 4. Motor brushes are worn. 5. Motor has overheated. 6. Motor is at fault. 	<ol style="list-style-type: none"> 1. Reduce tool pressure. 2. Test for good contacts; correct the wiring. 3. Test by rotating shaft; rotational grinding/loose shaft requires bearing replacement. 4. Replace brushes. 5. Clean off motor, let cool, and reduce workload. 6. Test/repair/replace.
Machine has vibration or noisy operation.	<ol style="list-style-type: none"> 1. Motor or component is loose. 2. Motor fan is rubbing on fan cover. 3. Workpiece or center/chuck is at fault. 4. Motor bearings are at fault. 	<ol style="list-style-type: none"> 1. Inspect/replace stripped or damaged bolts/nuts, and re-tighten with thread locking fluid. 2. Replace dented fan cover; replace loose/damaged fan. 3. Center workpiece on center/chuck or face plate; reduce RPM; replace defective center/chuck. 4. Test by rotating shaft; rotational grinding/loose shaft requires bearing replacement.



Wood Lathe Operation

Symptom	Possible Cause	Possible Solution
Vibration noise while machine is running; noise changes when speed is changed.	1. Belt cover loose.	1. If necessary, install a soft, vibration dampening material (between the belt cover and the headstock casting).
Vibration noise while machine is running; noise remains constant when speed is changed.	1. Dented fan cover on motor.	1. Replace or adjust fan cover. Inspect motor fan and replace if damaged.
Motor is running but spindle is not turning.	1. Belt is loose, broken, or has come off pulleys.	1. Inspect belt and tighten, reinstall, or replace if damaged.
Excessive vibration.	1. Workpiece mounted incorrectly. 2. Workpiece warped, out of round, or is flawed. 3. Spindle speed is set too fast for mounted workpiece. 4. Lathe is resting on an uneven surface. 5. Motor mount bolts are loose. 6. Belt is worn or damaged. 7. Spindle bearings are worn.	1. Re-mount workpiece, making sure that centers are embedded in true center of workpiece. 2. Cut workpiece to correct, or use a different workpiece. 3. Reduce the spindle speed. 4. Shim or adjust feet to remove any wobbles. 5. Tighten motor mount bolts. 6. Replace belt. 7. Replace spindle bearings.
Chisels grab or dig into workpiece.	1. Tool rest set too low. 2. Tool rest set too far from workpiece. 3. Wrong chisel/tool being used. 4. Chisel/tool dull.	1. Set tool rest higher. See Page 28 for how to properly set the tool rest height. 2. Move the tool rest closer to the workpiece. See Page 28 for the proper workpiece/tool rest clearance. 3. Use the correct chisel/tool; educate yourself by reading books, trade magazines, or seeking help from an experienced lathe operator. 4. Sharpen or replace the chisel/tool you are using.
Bad surface finish.	1. Wrong spindle speed. 2. Dull chisel or wrong chisel being used for the operation.	1. Use trial-and-error to find a better spindle speed. 2. Sharpen chisel or try a different chisel.
Tailstock moves.	1. Tailstock mounting bolt loose. 2. Too much clamping pressure applied by tailstock. 3. Bed surface is oily or greasy.	1. Tighten. 2. Apply less clamping pressure with tailstock. 3. Clean bed surface to remove oil/grease.
Spindle RPM display is not functioning.	1. Spindle RPM sensor is misaligned from sensor ring.	1. Align sensor ring to RPM sensor and set gap to approximately $\frac{1}{16}$ ".
Can't remove tapered tool from tailstock barrel.	1. Tailstock barrel had not retracted all the way back into the tailstock. 2. Debris was not removed from taper before inserting into barrel.	1. Turn the barrel handwheel until it forces taper out of barrel. 2. Always make sure that taper surfaces are clean.



Changing Belt

To remove the old belt:

1. DISCONNECT LATHE FROM POWER!
2. Release belt tension as described in **Changing Speed Ranges** on **Page 21**, then remove the belt from the lower pulley.
3. Loosen both set screws on the spindle handwheel (**Figure 51**), and turn it clockwise to unthread and remove it.

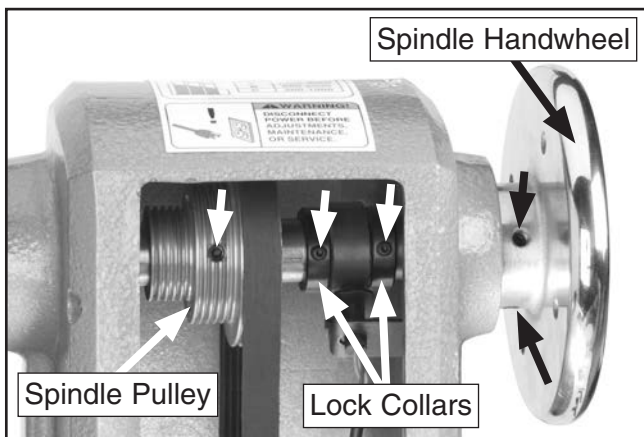

Figure 51 Set screw locations.

4. Loosen the set screw on the spindle pulley and both lock collars (refer to **Figure 51** for set screw locations).
5. Tap the spindle far enough out of the headstock that the belt can be removed. A rubber or wooden mallet may be required. Take care not to damage the spindle threads or to lose parts in the process (**Figure 52**).

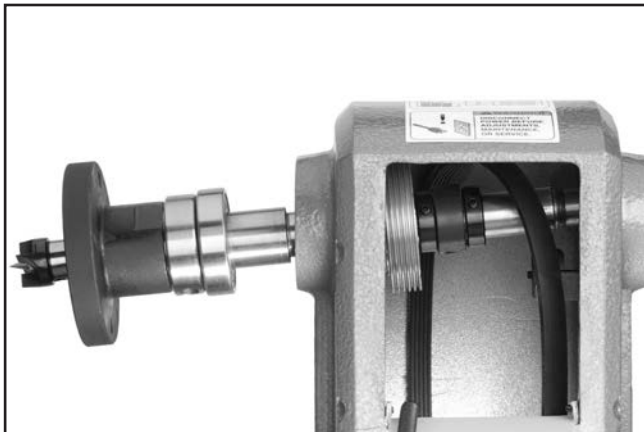

Figure 52. Belt removal.

To install new belt:

1. Place the new belt over the spindle pulley.
2. Slide the spindle back through the headstock and into the original position. A mallet may be required.
3. Install the headlock spindle handwheel and tighten both set screws.
4. Loosely install the belt on the motor pulley in the inner or outermost position.
5. Adjust the spindle pulley position on the spindle shaft to ensure proper belt alignment (**Figure 53**), then tighten the pulley set screw.

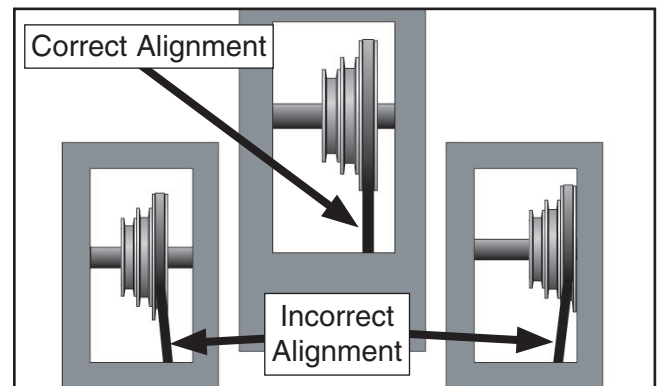

Figure 53. Proper belt alignment.

6. Position the spindle RPM sensor ring in-line with the RPM sensor. Slide the lock collars snug against each side of the sensor ring, then tighten the set screws (**Figure 54**).

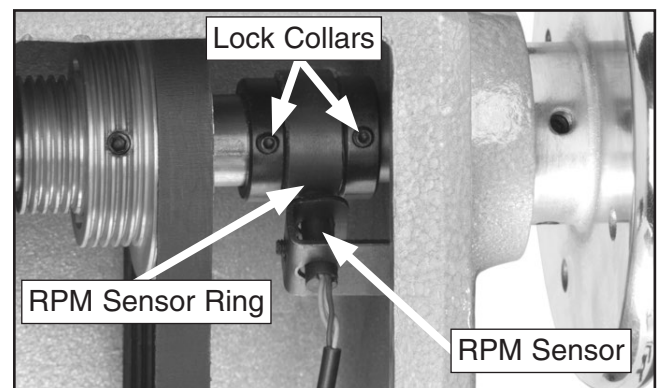

Figure 54. RPM sensor.

7. Complete the new belt installation by following **Steps 6-9** in the **Changing Speed Ranges** procedure on **Page 21**.



Motor Service

Keep the motor as clean as possible. Prevent any water, oil, or wood chips from penetrating inside the motor. Be sure to clean the machine after every use.

The bearings inside the motor are shielded and lubricated for the life of the bearing and require no routine maintenance.

This motor is equipped with long life carbon brushes. However, brush life expectancy is affected by motor loading. Heavy motor loading will result in reduced brush life. Check brushes after every ten to fifteen hours of operation (**Figure 55**).

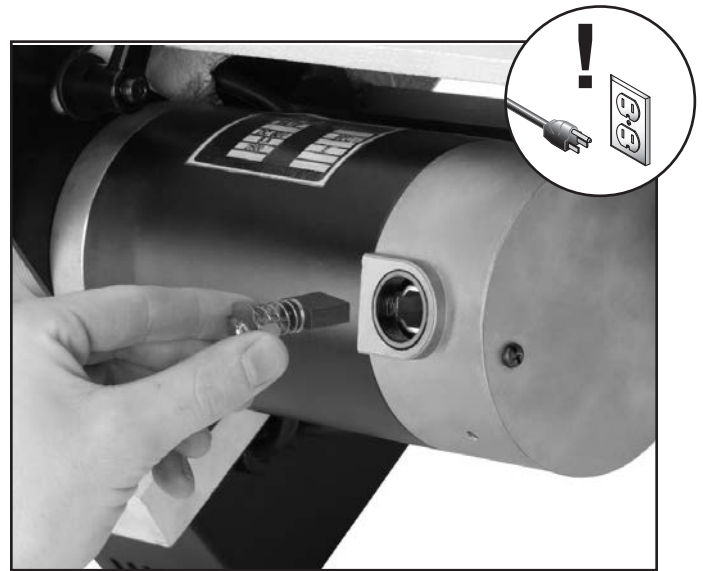

Figure 55. Brush holder location (another brush is located on the other side of the motor from the one shown in this picture).

When the brushes are worn down to $\frac{1}{4}$ " (6mm), it is time for replacement. When checking brushes, be sure to return each brush in the same position that it came from. When replacing old brushes, be sure to replace both brushes at the same time.



SECTION 8: WIRING

These pages are current at the time of printing. However, in the spirit of improvement, we may make changes to the electrical systems of future machines. Compare the manufacture date of your machine to the one stated in this manual, and study this section carefully.

If there are differences between your machine and what is shown in this section, call Technical Support at (570) 546-9663 for assistance BEFORE making any changes to the wiring on your machine. An updated wiring diagram may be available. **Note:** *Please gather the serial number and manufacture date of your machine before calling. This information can be found on the main machine label.*

WARNING

Wiring Safety Instructions

SHOCK HAZARD. Working on wiring that is connected to a power source is extremely dangerous. Touching electrified parts will result in personal injury including but not limited to severe burns, electrocution, or death. Disconnect the power from the machine before servicing electrical components!

MODIFICATIONS. Modifying the wiring beyond what is shown in the diagram may lead to unpredictable results, including serious injury or fire. This includes the installation of unapproved after-market parts.

WIRE CONNECTIONS. All connections must be tight to prevent wires from loosening during machine operation. Double-check all wires disconnected or connected during any wiring task to ensure tight connections.

CIRCUIT REQUIREMENTS. You MUST follow the requirements at the beginning of this manual when connecting your machine to a power source.

WIRE/COMPONENT DAMAGE. Damaged wires or components increase the risk of serious personal injury, fire, or machine damage. If you notice that any wires or components are damaged while performing a wiring task, replace those wires or components.

MOTOR WIRING. The motor wiring shown in these diagrams is current at the time of printing but may not match your machine. If you find this to be the case, use the wiring diagram inside the motor junction box.















CAPACITORS/INVERTERS. Some capacitors and power inverters store an electrical charge for up to 10 minutes after being disconnected from the power source. To reduce the risk of being shocked, wait at least this long before working on capacitors.

EXPERIENCING DIFFICULTIES. If you are experiencing difficulties understanding the information included in this section, contact our Technical Support at (570) 546-9663.

NOTICE

The photos and diagrams included in this section are best viewed in color. You can view these pages in color at www.grizzly.com.

COLOR KEY

BLACK 	BLUE 	YELLOW 	LIGHT BLUE 
WHITE 	BROWN 	YELLOW GREEN 	BLUE WHITE 
GREEN 	GRAY 	PURPLE 	TURQUOISE 
RED 	ORANGE 	PINK 	



G0657/G0658 Wiring Diagram

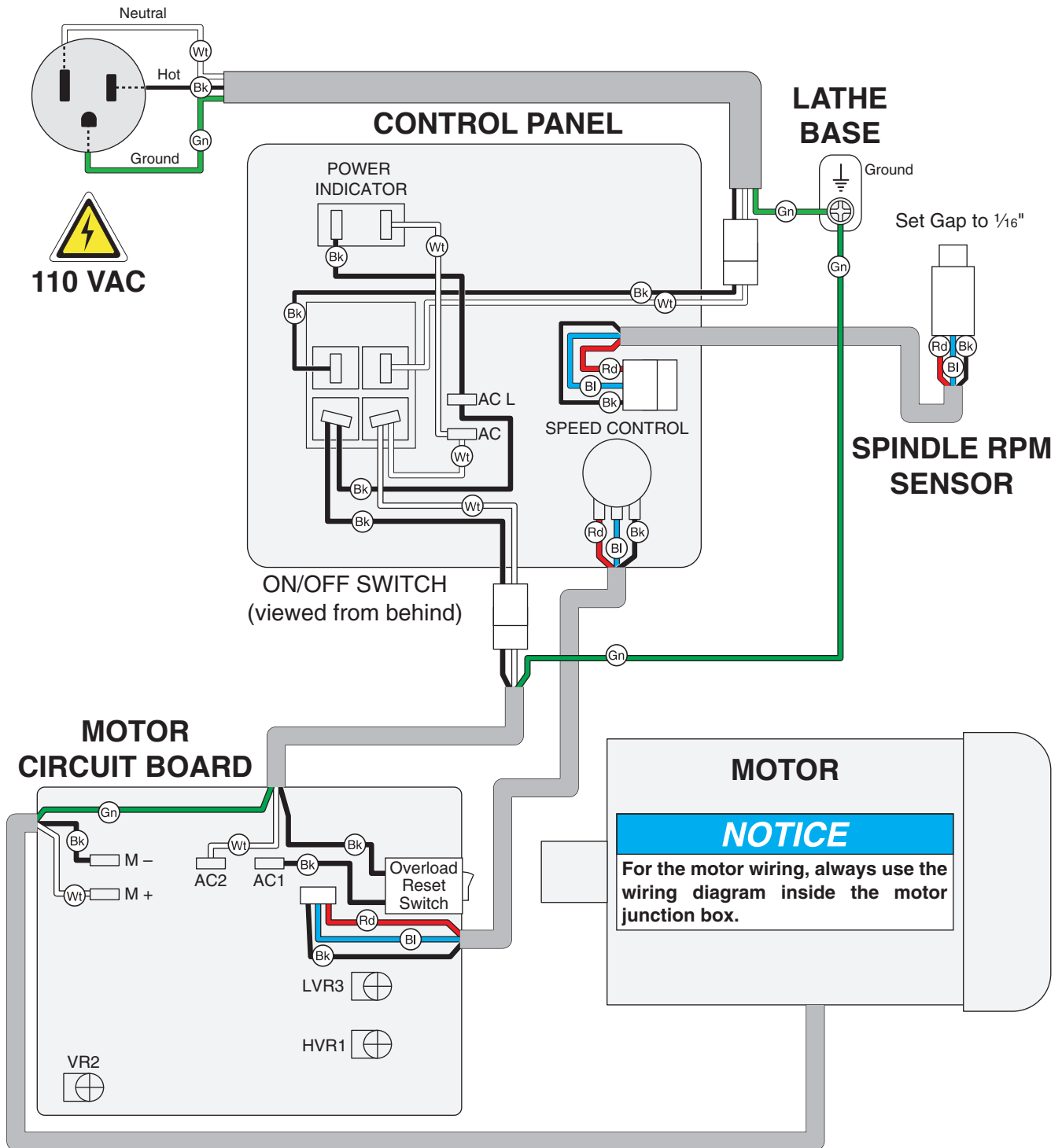

SECTION 9: PARTS

G0657 Main

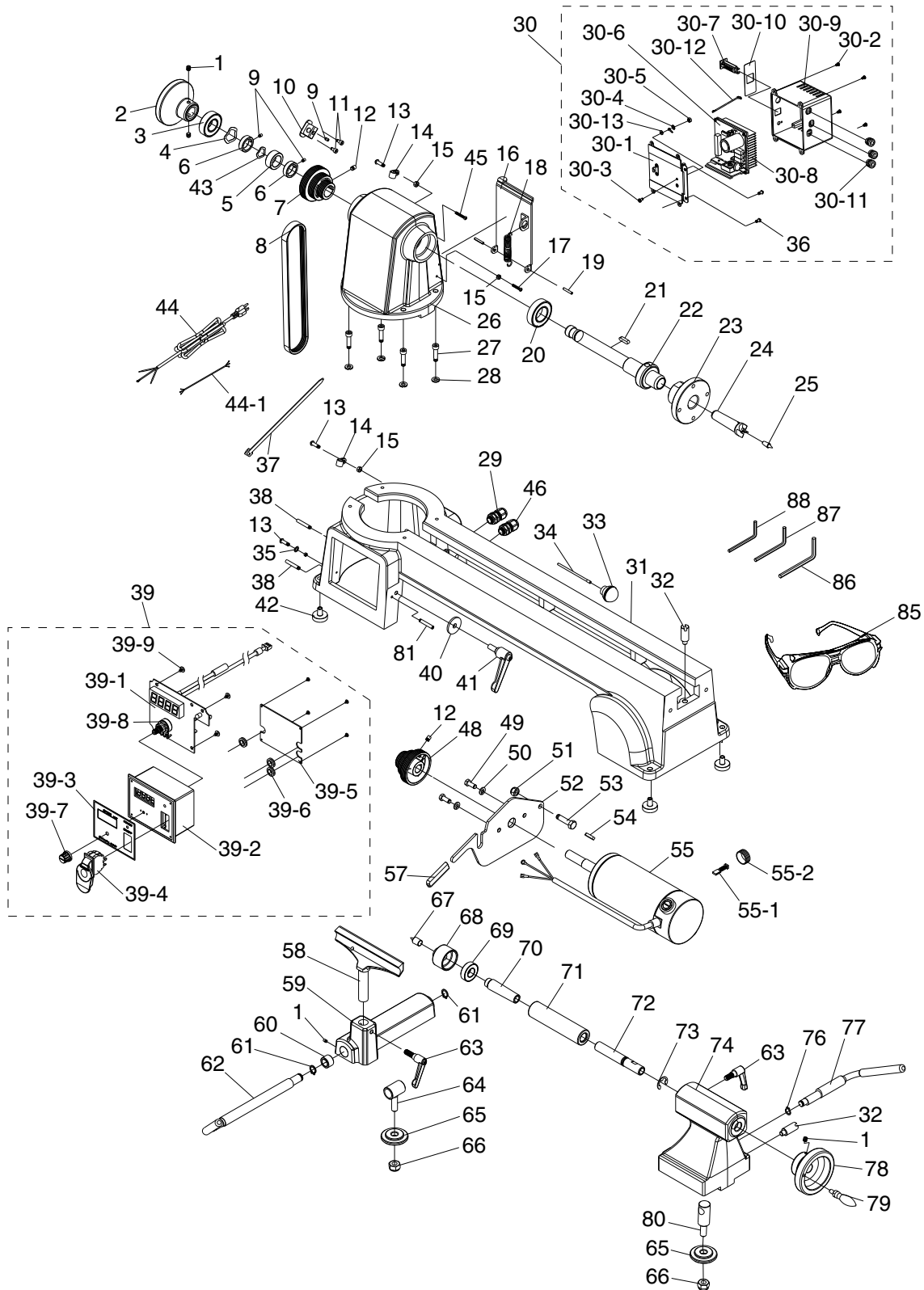

G0657 Main Parts List

REF	PART #	DESCRIPTION
1	PSS11	SET SCREW 1/4-20 x 1/4
2	P0657002	SPINDLE HANDWHEEL
3	P0657003	BALL BEARING 6004-2RS
4	P0657004	WAVE WASHER 20MM
5	P0657005	SENSOR RING
6	P0657006	COLLAR
7	P0657007	SPINDLE PULLEY
8	P0657008	RIBBED V-BELT 3/16 X 1/2 X 23
9	PSS79M	SET SCREW M4-.7 X 6
10	P0657010	SENSOR BRACKET
11	PSB18M	CAP SCREW M4-.7 X 8
12	PSS02M	SET SCREW M6-1 X 6
13	PS08	PHLP HD SCR 10-24 X 3/4
14	P0657014	CORD CLAMP
15	PN07	HEX NUT 10-24
16	P0657016	REAR ACCESS COVER
17	PS03	PHLP HD SCR 10-24 X 1
18	P0657018	TENSION SPRING
19	PRP42M	ROLL PIN 3 X 20
20	P0657020	BALL BEARING 6005-2RS
21	PK34M	KEY 5 X 5 X 20
22	P0657022	SPINDLE
23	P0657023	FACEPLATE
24	P0657024	SPUR CENTER
25	P0657025	CENTER POINTER
26	P0657026	HEADSTOCK
27	P0657027	CENTER POINT
28	PLW02	LOCK WASHER 1/4
29	P0657029	STRAIN RELIEF PGA13.5-11
30	P0657030	CONTROL BOX
30-1	P0657030-1	DOOR PLATE
30-2	PS17M	PHLP HD SCR M4-.7 X 6
30-3	PS06	PHLP HD SCR 10-24 X 3/8
30-5	PN07	HEX NUT 10-24
30-6	P0657030-6	MOTOR CIRCUIT BOARD
30-7	P0657030-7	OVERLOAD SWITCH
30-8	P0657030-8	HEAT SINK
30-9	P0657030-9	CASE
30-10	P0657030-10	RESET LABEL
30-11	P0657030-11	STRAIN RELIEF
30-12	P0657030-12	JUMPER WIRE

REF	PART #	DESCRIPTION
30-13	P0657030-13	EXT TOOTH WASHER #10
31	P0657031	LATHE BED
32	P0657032	END STOP
33	P0657033	KNOCKOUT BAR HANDLE
34	P0657034	KNOCKOUT BAR ROD
35	P0657035	EXT TOOTH WASHER #10
36	PHTEK4	TAP SCREW 10-24 X 3/8
37	P0657037	ZIP TIE
38	PSS34M	SET SCREW M5-.8 X 16
39	P0657039	ELECTRIC BOX
39-1	P0657039-1	CIRCUIT BOARD
39-2	P0657039-2	CONTROL BOX
39-3	P0657039-3	BOX COVER
39-4	P0657039-4	SWITCH
39-5	P0657039-5	BACK PLATE
39-6	P0657039-6	GROMMET
39-7	P0657039-7	KNOB
39-8	P0657039-8	SPEED CONTROL
39-9	PHTEK4	TAP SCREW 10-24 X 3/8
40	P0657040	SPECIAL WASHER 8MM
41	P0657041	LEVER ASSEMBLY
42	P0657042	LEVELING FOOT
43	P0657043	WAVE WASHER 21MM
44	P0657044	POWER CORD
44-1	P0657044-1	WIRE HARNESS
45	PS08	PHLP HD SCR 10-24 X 3/4
46	P0657046	STRAIN RELIEF MG16A-10B-ST
48	P0657048	MOTOR PULLEY
49	PB02	HEX BOLT 1/4-20 X 5/8
50	PLW02	LOCK WASHER 1/4
51	PLN03	LOCK NUT 5/16-18
52	P0657052	MOTOR PLATE
53	PB12	HEX BOLT 5/16-18 X 1-1/4
54	PK48M	KEY 4 X 4 X 20
55	P0657055	MOTOR 1/2 HP 110V DC
55-1	P0657055-1	MOTOR BRUSH
55-2	P0657055-2	MOTOR BRUSH CAP
57	P0657057	RUBBER HANDLE
58	P0657058	TOOL REST
59	P0657059	TOOL REST BASE



G0657 Main Parts List (Cont'd)

REF	PART #	DESCRIPTION
60	P0657060	BUSHING
61	PR03M	EXT RETAINING RING 12MM
62	P0657062	ECCENTRIC ROD
63	P0657063	TOOL REST LOCK HANDLE
64	P0657064	CLAMP BOLT
65	P0657065	CLAMP PLATE
66	PLN05M	LOCK NUT M10-1.5
67	P0657067	CENTER POINT
68	P0657068	LIVE CENTER HEAD
69	P0657069	BALL BEARING 6002ZZ
70	P0657070	LIVE CENTER SHAFT
71	P0657071	TAILSTOCK QUILL
72	P0657072	LEADSCREW

REF	PART #	DESCRIPTION
73	PEC12M	E-CLIP 12MM
74	P0657074	TAILSTOCK
76	PR01M	EXT RETAINING RING 10MM
77	P0657077	TAILSTOCK LEVER
78	P0657078	QUILL HANDWHEEL
79	P0657079	HANDWHEEL HANDLE
80	P0657080	TAILSTOCK CLAMP BOLT
81	PSS24M	SET SCREW M5-.8 X 25
85	P0657085	SAFETY GLASSES
86	PAW05M	HEX WRENCH 5MM
87	PAW03M	HEX WRENCH 3MM
88	PAW02.5M	HEX WRENCH 2.5MM



G0657 Labels

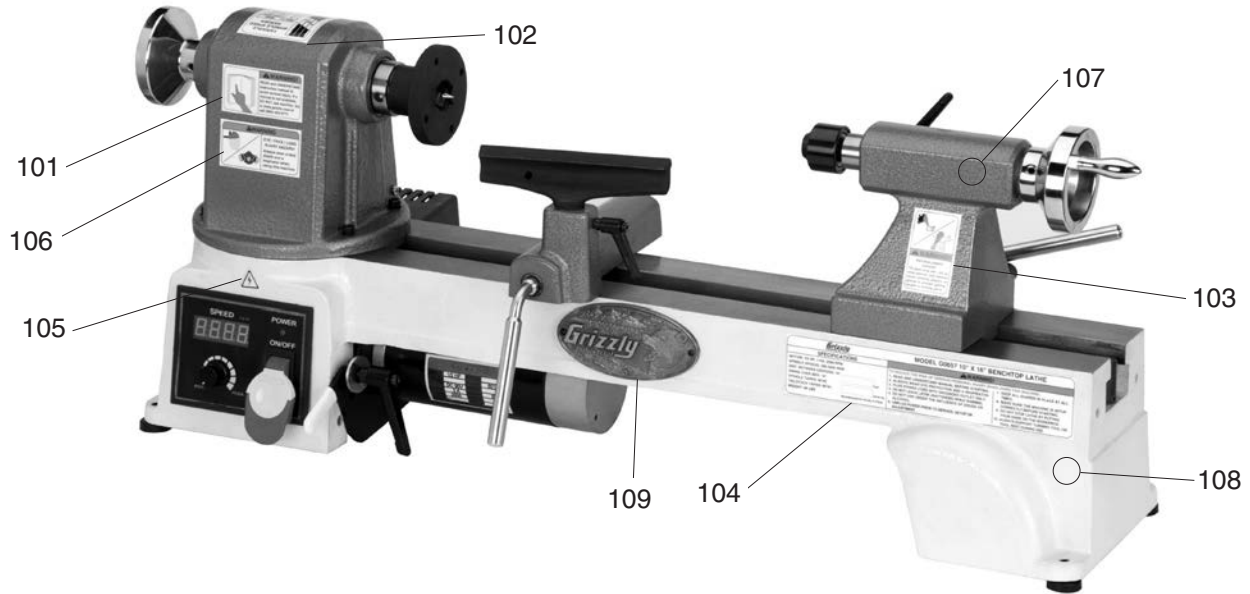

REF	PART #	DESCRIPTION
101	P0657101	READ MANUAL LABEL
102	P0657102	SPINDLE SPEED LABEL
103	P0657103	ENTANGLEMENT HAZARD
104	P0657104	MACHINE ID LABEL
105	PLABEL-14	ELECTRICITY LABEL

REF	PART #	DESCRIPTION
106	P0657106	EYE/FACE/LUNG LABEL
107	PPAINT-1	GRIZZLY GREEN TOUCH UP PAINT
108	PPAINT-11	GRIZZLY PUTTY TOUCH UP PAINT
109	G8588	GRIZZLY NAMEPLATE- SMALL

WARNING

Safety labels warn about machine hazards and ways to prevent injury. The owner of this machine **MUST** maintain the original location and readability of the labels on the machine. If any label is removed or becomes unreadable, **REPLACE** that label before using the machine again. Contact Grizzly at (800) 523-4777 or www.grizzly.com to order new labels.



G0658 Main

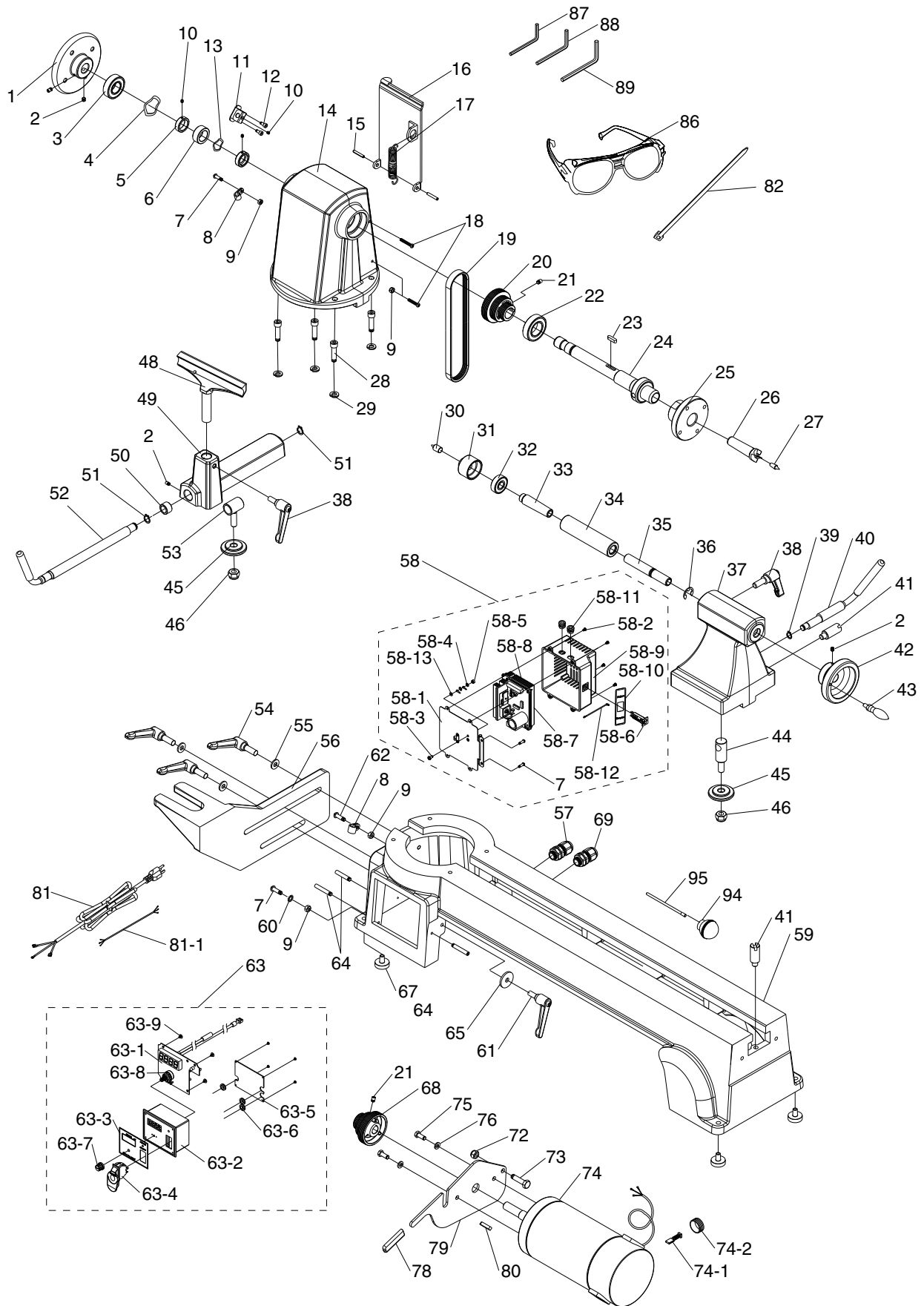

G0658 Main Parts List

REF	PART #	DESCRIPTION
1	P0658001	SPINDLE HANDWHEEL
2	P0658002	SET SCREW 1/4-20 X 1/4
3	P0658003	BALL BEARING 6004-2RS
4	P0658004	WAVE WASHER 20MM
5	P0658005	COLLAR
6	P0658006	SENSOR RING
7	P0658007	PHLP HD SCR 10-24 X 5/8
8	P0658008	CORD CLAMP
9	P0658009	HEX NUT 10-24
10	P0658010	SET SCREW M4-.7 X 4
11	P0658011	SENSOR BRACKET
12	P0658012	CAP SCREW 5/32-32 X 3/8
13	P0658013	WAVE WASHER 20MM
14	P0658014	HEADSTOCK
15	P0658015	ROLL PIN 3 X 20
16	P0658016	REAR ACCESS COVER
17	P0658017	TENSION SPRING
18	P0658018	PHLP HD SCR 10-24 x 1-1/2
19	P0658019	RIBBED V-BELT 260J4
20	P0658020	SPINDLE PULLEY
21	P0658021	SET SCREW M6-1 X 8
22	P0658022	BALL BEARING 6005-2RS
23	P0658023	KEY 5 X 5 X 20
24	P0658024	SPINDLE
25	P0658025	FACEPLATE
26	P0658026	SPUR CENTER
27	P0658027	CENTER POINTER
28	P0658028	CAP SCREW 5/16-18 X 1
29	P0658029	LOCK WASHER 5/16
30	P0658030	LIVE CENTER POINT
31	P0658031	LIVE CENTER HEAD
32	P0658032	BALL BEARING 6002ZZ
33	P0658033	LIVE CENTER SHAFT
34	P0658034	TAILSTOCK QUILL
35	P0658035	LEADSCREW
36	P0658036	E-CLIP 12MM

REF	PART #	DESCRIPTION
37	P0658037	TAILSTOCK
38	P0658038	HANDLE ASSEMBLY
39	P0658039	EXT RETAINING RING 10MM
40	P0658040	TAILSTOCK LEVER
41	P0658041	END STOP
42	P0658042	HANDWHEEL
43	P0658043	HANDWHEEL KNOB
44	P0658044	TAILSTOCK CLAMP BOLT
45	P0658045	CLAMP PLATE
46	P0658046	LOCK NUT M10-1.5
48	P0658048	TOOL REST
49	P0658049	TOOL REST BODY
50	P0658050	BUSHING
51	P0658051	EXT RETAINING RING 12MM
52	P0658052	ECCENTRIC ROD
53	P0658053	CLAMP BOLT
54	P0658054	LARGE HANDLE ASSEMBLY
55	P0658055	FLAT WASHER 10MM
56	P0658056	OUTBOARD TURNING BRACKET
57	P0658057	STRAIN RELIEF MG20A-14B-ST
58	P0658058	CONTROL BOX
58-1	P0658058-1	DOOR PLATE
58-2	P0658058-2	PHLP HD SCR M4-.7 X 6
58-3	P0658058-3	PHLP HD SCR 10-24 X 3/8
58-4	P0658058-4	EXT TOOTH WASHER #10
58-5	P0658058-5	HEX NUT 10-24
58-6	P0658058-6	OVERLOAD SWITCH
58-7	P0658058-7	MOTOR CIRCUIT BOARD
58-8	P0658058-8	HEAT SINK
58-9	P0658058-9	CASE
58-10	P0658058-10	RESET LABEL
58-11	P0658058-11	SMALL STRAIN RELIEF
58-12	P0658058-12	JUMPER WIRE
58-13	P0658058-13	EXT TOOTH WASHER #10
59	P0658059	LATHE BED
60	P0658060	EXT TOOTH WASHER #10



G0658 Main Parts List (cont'd)

REF	PART #	DESCRIPTION
61	P0658061	LEVER ASSEMBLY
62	P0658062	PHLP HD SCR 10-24 X 7/8
63	P0658063	ELECTRIC BOX
63-1	P0658063-1	CIRCUIT BOARD
63-2	P0658063-2	CONTROL BOX
63-3	P0658063-3	BOX COVER
63-4	P0658063-4	SWITCH
63-5	P0658063-5	BACK PLATE
63-6	P0658063-6	WIRE GROMMET
63-7	P0658063-7	KNOB
63-8	P0658063-8	SPEED CONTROL
63-9	P0658063-9	TAP SCREW 10-24 X 3/8
64	P0658064	SET SCREW M5-.8 X 15
65	P0658065	FLAT WASHER 8MM
67	P0658067	LEVELING FOOT
68	P0658068	MOTOR PULLEY
69	P0658069	STRAIN RELIEF MG16A-10B-ST
72	P0658072	LOCK NUT 5/16-18

REF	PART #	DESCRIPTION
73	P0658073	HEX BOLT 5/16-18 X 1-1/4
74	P0658074	MOTOR 3/4 HP 110V DC
74-1	P0658074-1	MOTOR BRUSH
74-2	P0658074-2	MOTOR BRUSH CAP
75	P0658075	HEX BOLT M6-1 X 16
76	P0658076	LOCK WASHER 6MM
78	P0658078	RUBBER HANDLE
79	P0658079	MOTOR PLATE
80	P0658080	KEY 4 X 4 X 20
81	P0658081	POWER CORD
81-1	P0658081-1	WIRING HARNESS
82	P0658082	ZIP TIE
86	P0658086	SAFETY GLASSES
87	P0658087	HEX WRENCH 2.5MM
88	P0658088	HEX WRENCH 3MM
89	P0658089	HEX WRENCH 6MM
94	P0658094	KNOCKOUT BAR HANDLE
95	P0658095	KNOCKOUT BAR ROD



G0658 Labels

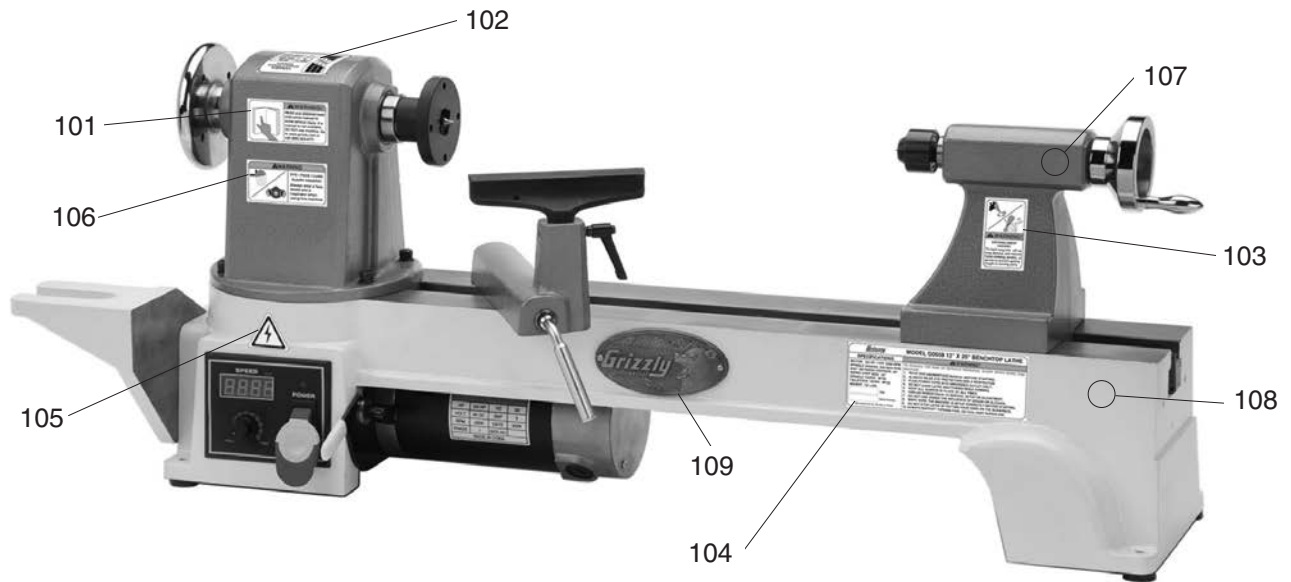

REF	PART #	DESCRIPTION
101	P0658101	READ MANUAL LABEL
102	P0658102	SPINDLE SPEED LABEL
103	P0658103	ENTANGLEMENT HAZARD
104	P0658104	MACHINE ID LABEL
105	P0658105	ELECTRICITY LABEL

REF	PART #	DESCRIPTION
106	P0658106	EYE/FACE/LUNG LABEL
107	P0658107	GRIZZLY GREEN TOUCH UP PAINT
108	P0658108	GRIZZLY PUTTY TOUCH UP PAINT
109	P0658109	GRIZZLY NAMEPLATE- SMALL

!WARNING

Safety labels warn about machine hazards and ways to prevent injury. The owner of this machine **MUST** maintain the original location and readability of the labels on the machine. If any label is removed or becomes unreadable, **REPLACE** that label before using the machine again. Contact Grizzly at (800) 523-4777 or www.grizzly.com to order new labels.





WARRANTY CARD

Name _____
 Street _____
 City _____ State _____ Zip _____
 Phone # _____ Email _____
 Model # _____ Order # _____ Serial # _____

The following information is given on a voluntary basis. It will be used for marketing purposes to help us develop better products and services. **Of course, all information is strictly confidential.**

1. How did you learn about us?

<input type="checkbox"/> Advertisement	<input type="checkbox"/> Friend	<input type="checkbox"/> Catalog
<input type="checkbox"/> Card Deck	<input type="checkbox"/> Website	<input type="checkbox"/> Other:

2. Which of the following magazines do you subscribe to?

<input type="checkbox"/> Cabinetmaker & FDM	<input type="checkbox"/> Popular Science	<input type="checkbox"/> Wooden Boat
<input type="checkbox"/> Family Handyman	<input type="checkbox"/> Popular Woodworking	<input type="checkbox"/> Woodshop News
<input type="checkbox"/> Hand Loader	<input type="checkbox"/> Precision Shooter	<input type="checkbox"/> Woodsmith
<input type="checkbox"/> Handy	<input type="checkbox"/> Projects in Metal	<input type="checkbox"/> Woodwork
<input type="checkbox"/> Home Shop Machinist	<input type="checkbox"/> RC Modeler	<input type="checkbox"/> Woodworker West
<input type="checkbox"/> Journal of Light Cont.	<input type="checkbox"/> Rifle	<input type="checkbox"/> Woodworker's Journal
<input type="checkbox"/> Live Steam	<input type="checkbox"/> Shop Notes	<input type="checkbox"/> Other:
<input type="checkbox"/> Model Airplane News	<input type="checkbox"/> Shotgun News	
<input type="checkbox"/> Old House Journal	<input type="checkbox"/> Today's Homeowner	
<input type="checkbox"/> Popular Mechanics	<input type="checkbox"/> Wood	

3. What is your annual household income?

<input type="checkbox"/> \$20,000-\$29,000	<input type="checkbox"/> \$30,000-\$39,000	<input type="checkbox"/> \$40,000-\$49,000
<input type="checkbox"/> \$50,000-\$59,000	<input type="checkbox"/> \$60,000-\$69,000	<input type="checkbox"/> \$70,000+

4. What is your age group?

<input type="checkbox"/> 20-29	<input type="checkbox"/> 30-39	<input type="checkbox"/> 40-49
<input type="checkbox"/> 50-59	<input type="checkbox"/> 60-69	<input type="checkbox"/> 70+

5. How long have you been a woodworker/metalworker?

<input type="checkbox"/> 0-2 Years	<input type="checkbox"/> 2-8 Years	<input type="checkbox"/> 8-20 Years	<input type="checkbox"/> 20+ Years
------------------------------------	------------------------------------	-------------------------------------	------------------------------------

6. How many of your machines or tools are Grizzly?

<input type="checkbox"/> 0-2	<input type="checkbox"/> 3-5	<input type="checkbox"/> 6-9	<input type="checkbox"/> 10+
------------------------------	------------------------------	------------------------------	------------------------------

7. Do you think your machine represents a good value? Yes No

8. Would you recommend Grizzly Industrial to a friend? Yes No

9. Would you allow us to use your name as a reference for Grizzly customers in your area?
Note: We never use names more than 3 times. Yes No

10. Comments: _____

CUT ALONG DOTTED LINE

FOLD ALONG DOTTED LINE



Place Stamp Here



GRIZZLY INDUSTRIAL, INC.
P.O. BOX 2069
BELLINGHAM, WA 98227-2069



FOLD ALONG DOTTED LINE

Send a Grizzly Catalog to a friend:

Name _____
Street _____
City _____ State _____ Zip _____

TAPE ALONG EDGES--PLEASE DO NOT STAPLE

WARRANTY AND RETURNS

Grizzly Industrial, Inc. warrants every product it sells for a period of **1 year** to the original purchaser from the date of purchase. This warranty does not apply to defects due directly or indirectly to misuse, abuse, negligence, accidents, repairs or alterations or lack of maintenance. This is Grizzly's sole written warranty and any and all warranties that may be implied by law, including any merchantability or fitness, for any particular purpose, are hereby limited to the duration of this written warranty. We do not warrant or represent that the merchandise complies with the provisions of any law or acts unless the manufacturer so warrants. In no event shall Grizzly's liability under this warranty exceed the purchase price paid for the product and any legal actions brought against Grizzly shall be tried in the State of Washington, County of Whatcom.

We shall in no event be liable for death, injuries to persons or property or for incidental, contingent, special, or consequential damages arising from the use of our products.

To take advantage of this warranty, contact us by mail or phone and give us all the details. We will then issue you a "Return Number," which must be clearly posted on the outside as well as the inside of the carton. We will not accept any item back without this number. Proof of purchase must accompany the merchandise.

The manufacturers reserve the right to change specifications at any time because they constantly strive to achieve better quality equipment. We make every effort to ensure that our products meet high quality and durability standards and we hope you never need to use this warranty.

Please feel free to write or call us if you have any questions about the machine or the manual.

Thank you again for your business and continued support. We hope to serve you again soon.

grizzly.com[®]

TOOL WEBSITE

Buy Direct and Save with Grizzly[®] – Trusted, Proven and a Great Value!
~Since 1983~

*Visit Our Website Today For
Current Specials!*

**ORDER
24 HOURS A DAY!
1-800-523-4777**

