

Installation, Operation, and Maintenance Manual

GENERAL J 5 @ 9^o Tfi GYU^{HA}

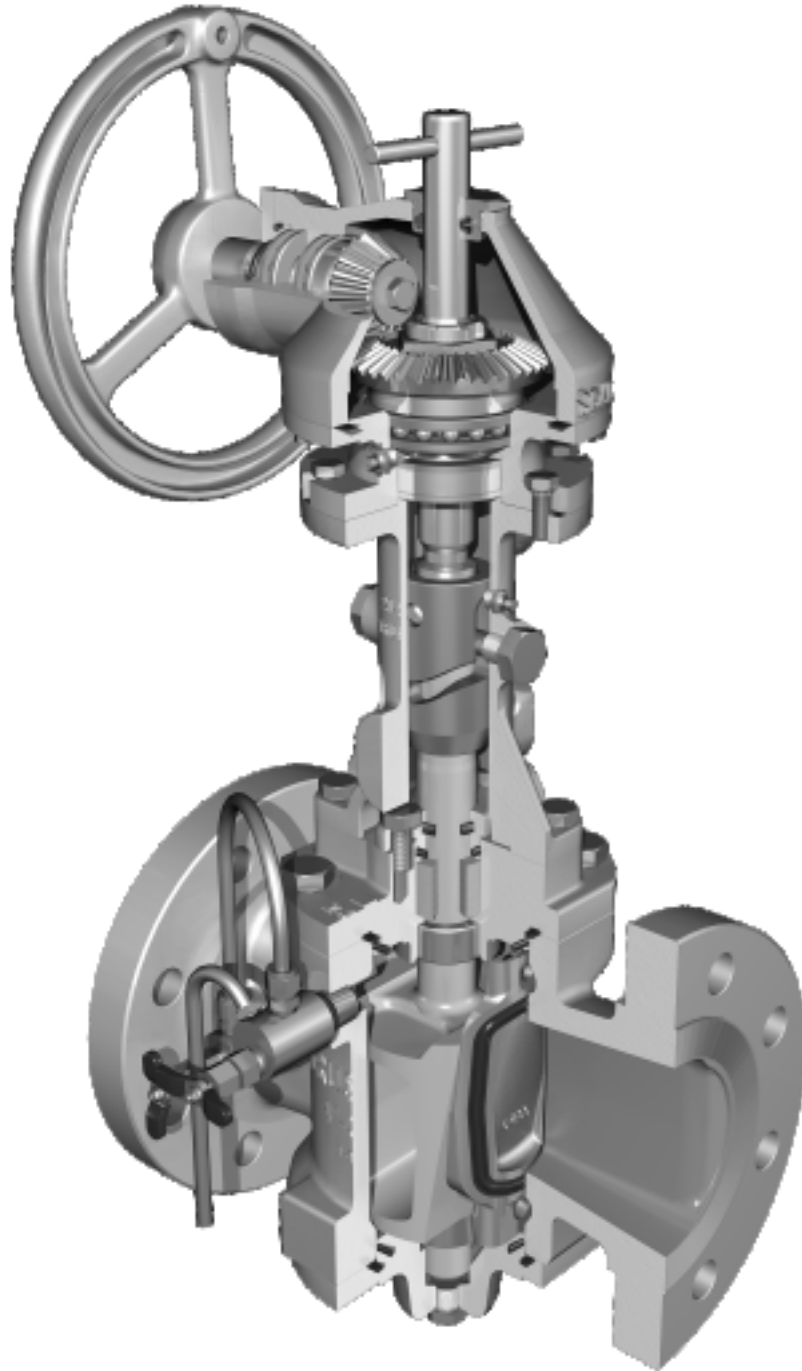

GENERAL VALVE[®]

V0EŠ0ÁU0Á0U P V0P VÙ

Ö0P ÖÙ0EŠX0EŠX0ÁÜWÙ0EŠX0EŠX0Ù
 Q•cæ|æā } A
 Xæç^ÁU] ^|æā } A
 U] ^|æā * ÁQ•d &çā } • A
 Úæ• ÁSā A
 Ó|^áÁU•c{ • A
 Ü^] æā A
 Øā|áÁU|çā^ÁÖ ã^A
 U] ^|æā | ÁQ•]^&çā } A



©Cameron's Valves & Measurement Group Revised 10/07 IOM-GEN-TRUSEAL

INSTALLATION

ORIENTATION

GENERAL VALVE TruSeal valves may be installed in any position.

FLOW DIRECTION

The GENERAL VALVE TruSeal valve design is symmetrical. Flow shut-off is achieved equally on both sides, independent of flow direction.

Note: Read the section on Thermal Relief Accessories, on pages 6-7, which DO result in a preferred flow direction.

CLEARANCE FOR REPAIR

For easy repair, space should be allowed below the valve for removal of the lower plate and withdrawal of the seating slips. See Table 1 for dimensions. Sufficient clear space is required above the GENERAL VALVE TruSeal valve, to allow free movement of the position indicator flag and for removal of the operator mechanism.

TABLE 1

CLEARANCE REQUIRED BELOW THE VALVE FOR SLIP REMOVAL

Valve Size	Minimum Clearance		
	ASME 150	ASME 300	ASME 600
2"	3"	3"	3"
3"	3"	3"	3"
4"	5"	5"	4"
6"	8"	9"	8"
8"	10"	9"	7"
10"	12"	12"	11"
12"	15"	14"	14"
14"	16"	16"	-
16"	18"	18"	-
18"	18"	18"	-
20"	22"	24"	-
24"	26"	-	-
30"	30"	-	-

Note: Allowing more than the specified minimum amount of clearance will make servicing easier.

FLANGE FASTENERS

Certain GENERAL VALVE TruSeal flange holes are drilled and tapped, when there is no possibility of fitting a hexagonal nut behind the flange. The quantity and size of these tapped holes is shown on Table 2. Capscrews or stud bolts may be used in these holes.

TABLE 2

FLANGE FASTENERS

Valve Size		Number of Tapped Holes Per Flange	Thread UNC	Length Required Capscrews or Stud Bolts	
inch	ASME Class			inch	inch
6	150	4	3/4"-10	2	3
8	150	4	3/4"-10	2	3
10	150	4	7/8"-9	2 1/4	3 1/2
12	150	4	7/8"-9	2 1/4	3 1/2
14	150	4	1"-8	2 1/2	3 3/4
16	150	8	1"-8	2 1/2	3 3/4
18	150	8	1 1/8"-8	2 3/4	4
8	300	4	7/8"-9	2 3/4	4
10	300	4	1"-8	3	5

PRESSURE TEST

GENERAL VALVE TruSeal valves can be hydrostatically pressure-tested after installation, to full API 6D limits as defined below.

TABLE 3

PRESSURE TEST

Valve Figure No.	211	221	241	Comments
ASME Class	150	300	600	
Shell Test Pressure (Valve Open)	(psig) 500 (kg/cm2) 35	1200 85	2250 158	No leakage permitted
Seat Test Pressure (Valve Closed)	(psig) 300 (kg/cm2) 21	800 56	1600 113	Test upstream and downstream seats. No leakage permitted.
Supplemental (API 598) Air Seat Test Pressure (Valve Closed)	(psig) 80 (psig) 6	80 6	80 6	Test upstream and downstream seats. No leakage permitted.

GEAR-HEAD ORIENTATION

When GENERAL VALVE TruSeal gear operators are used, the orientation of the handwheel shaft can be changed to suit operational requirements. Follow these instructions to change gear-head orientation. (See page 4 for parts reference).

- Remove all the gear housing bolts (part no. 42), but support the weight of the handwheel and shaft.
- Turn the handwheel so that the gear housing rotates to the desired position.
- Align the bolt holes and replace the gear housing bolts.

ICE WARNING: Water in the bottom of the GENERAL VALVE TruSeal valve must be drained before freezing conditions occur.

Ice below the plug can exert enough force to destroy the operator mechanism. Drain any water from plugged holes in the lower plate. The valve must be in the closed position before removing plugs.

VALVE OPERATION

OPENING

1. Valve fully closed, plug is down with the resilient seals compressed against the valve body.

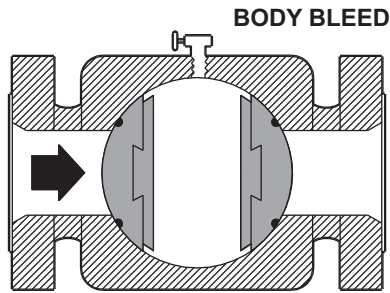

2. Plug raised with seals retracted from the body contact by dovetail connection.

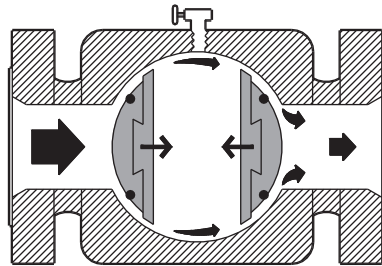

3. Plug turning to open position. No seal to body contact. Line load carried on plug trunnions.

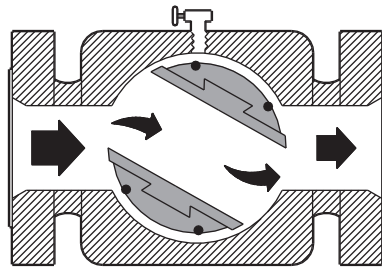

4. Valve is fully open with seals protected from flow path.

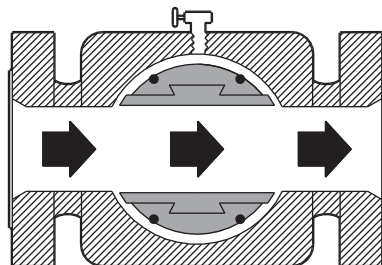

CLOSING

5. Valve is fully open with seals protected from flow path.

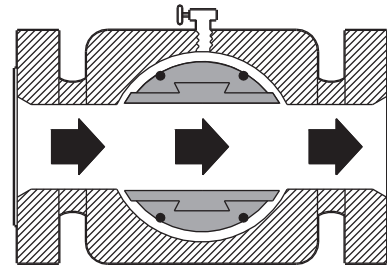

6. Plug turning toward the closed position. Resilient seals held away from body by dovetail connections.

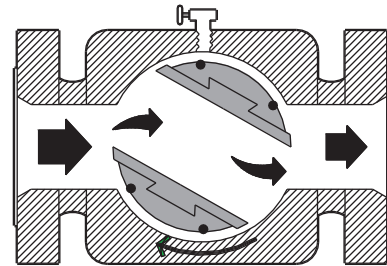

7. Plug turned a full 90°, positioning the seals over both the upstream and downstream ports.

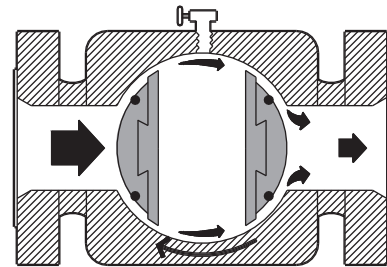

8. Plug down, seals expanded outward against body. Valve fully closed.

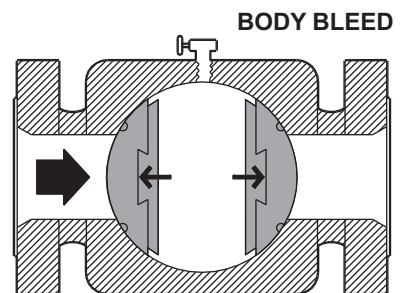

OPERATION INSTRUCTIONS

LIFT AND TURN

GENERAL TRUSEAL™ Valve is a lift-and-turn plug valve. The valve operator mechanism converts the rotary action of the handwheel into the thrust and turn movement of the plug.

BEFORE USE

Before operational use, check that the isolation valve on the thermal relief or automatic body bleed, if applicable, is fully open to allow the system to function. If the valve is equipped with a manual body bleed only, then open and close the manual bleed valve to relieve the internal body pressure, before attempting to open a closed GENERAL TRUSEAL™ Valve.

OPERATION

Clockwise turning of the handwheel will close the valve.

Counter-clockwise turning of the handwheel will open the valve.

CLOSING

Close the GENERAL TRUSEAL valve until resistance is felt. The soft seals have made contact with the body. Turn the handwheel further to compress the soft seals until there is a definite feel of "end of travel".

Now the soft seals are fully compressed, metal-against-metal, giving fire safe seating. Firm, positive turning of the handwheel is sufficient to seal the valve. Verify tight sealing by opening the manual body bleed valve or by observing any other bleed system fitted. Pressure release is normal. Constant dripping is normal. See page 11, if dripping continues.

OPENING

If a manual bleed alone is fitted, open it and close it, to release any thermal pressure build up. Turn the GENERAL TRUSEAL™ Valve handwheel counter clockwise until definite "end of travel" can be felt. Do not force or slam the handwheel fully open. The end of travel is pre-set to ensure port alignment. Do not "back-off" a partial turn from fully open.

INDICATOR FLAG

The indicator flag shows the position of the plug port at all times. Positioned at right angles to the pipeline and down, shows the GENERAL TRUSEAL™ Valve is closed. In-line with the pipeline and up, shows the GENERAL TRUSEAL™ Valve is open.

CAUTION

Do not throttle with a GENERAL TRUSEAL™ Valve. Even though GENERAL TRUSEAL™ Valves cannot slam shut, they should only be open or closed. Never leave a GENERAL TRUSEAL™ Valve in a half-way position. The soft resilient seals can be eroded by high velocity flow that occurs if the valve is used in the partially open position.

ROUTINE ATTENTION

GENERAL TRUSEAL™ Valves require no routine maintenance for positive sealing performance. Occasional injection of bearing grease, depending on the frequency of operations, will keep the turning action smooth. A grease point is located near the handwheel.

Never use wheelkeys, cheaters, or extension poles on the valve handwheels.

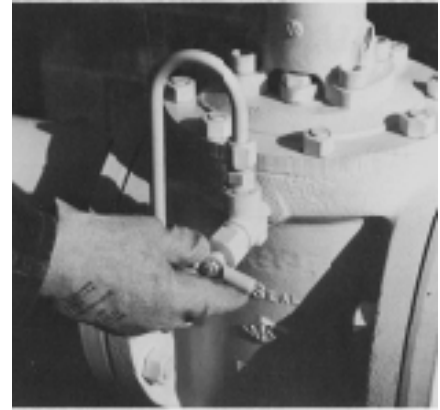

MANUAL BODY BLEED (MBV)



MANUAL BLEED WITH THERMAL RELIEF (MTR)

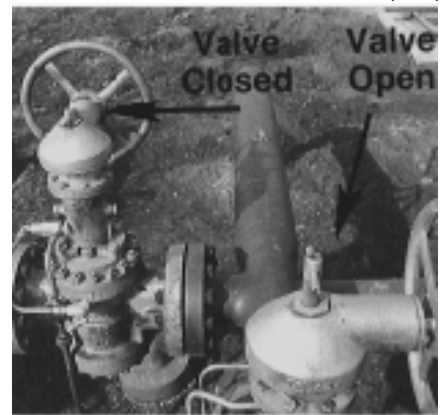

INDICATOR FLAG



DO NOT USE FORCE!

PARTS LIST

Valve Body Section

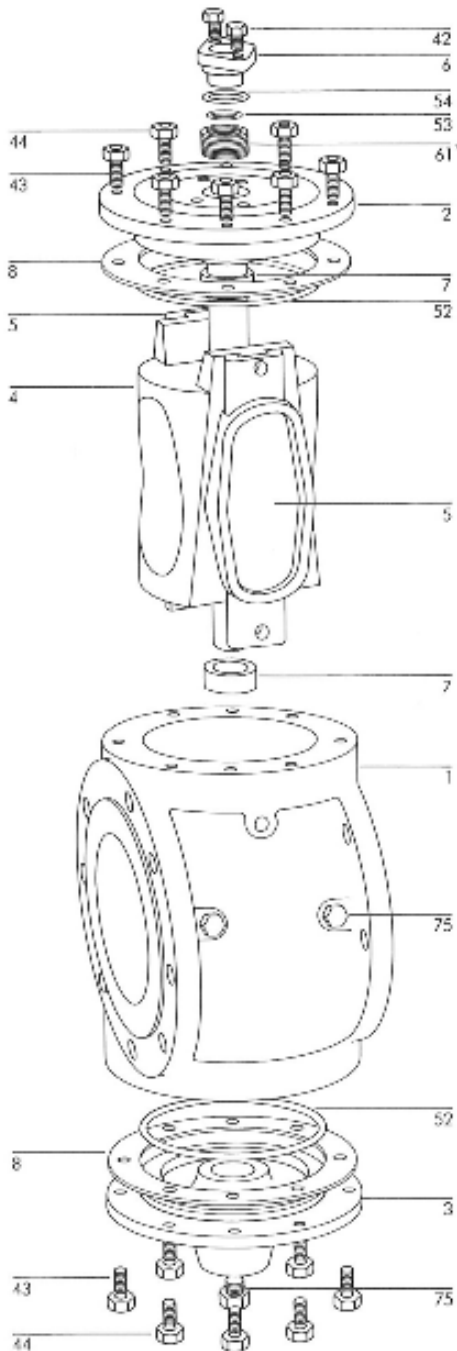

No.	Description
1	Body
2	Bonnet
3	Lower Plate
4	Plug
5	Slip
6	Packing Gland
7	Bushing
8*	Gasket (flat or spiral wound)

No.	Description
42	Packing Gland Bolt
43	Body Stud
44	Body Nut
52	Body O-Ring
53	Inner Gland O-Ring
54	Outer Gland O-Ring
61*	V-Packing Set or Graphite Rings
75	Body Drain Pipe Plug

Gear System Operator

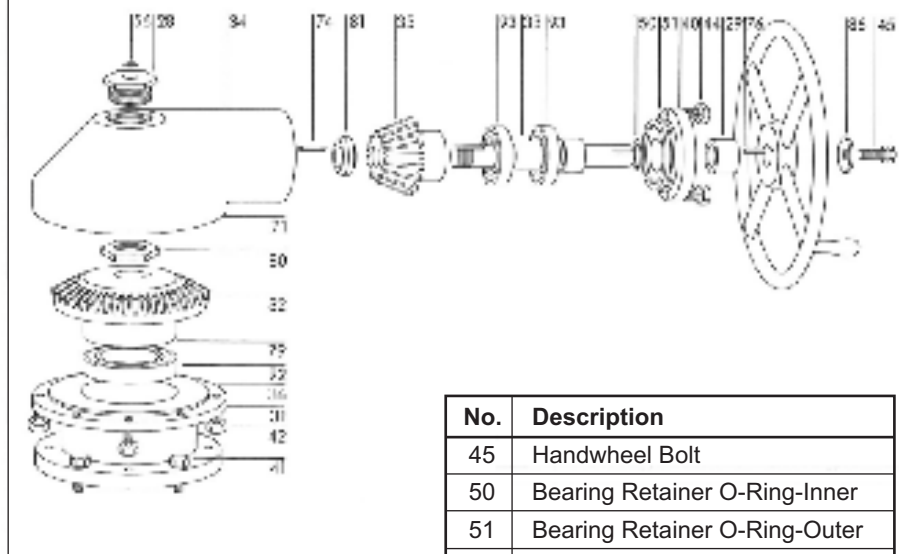

No.	Description
28	Dust Plug
29	Handwheel Spacer
31	Bearing Spool
32	Gear
33	Pinion Shaft
34	Gear Housing
35	Pinion
40	Bearing Retainer
41	Bearing Spool Bolt
42	Gear Housing Bolt
44	Bearing Retainer Bolt

No.	Description
45	Handwheel Bolt
50	Bearing Retainer O-Ring-Inner
51	Bearing Retainer O-Ring-Outer
56	Dust Cap O-Ring
74	Pinion Key
76	Handwheel Key
80	Gear Locknut
81	Pinion Locknut
86	Washer
92	Ball Bearing
93	Ball Bearing

No.	Not Shown
36	Shim Set
71	Grease Fitting
79	Gear Key

* Specify valve serial number when ordering parts.

PARTS LIST

200 Series Operator

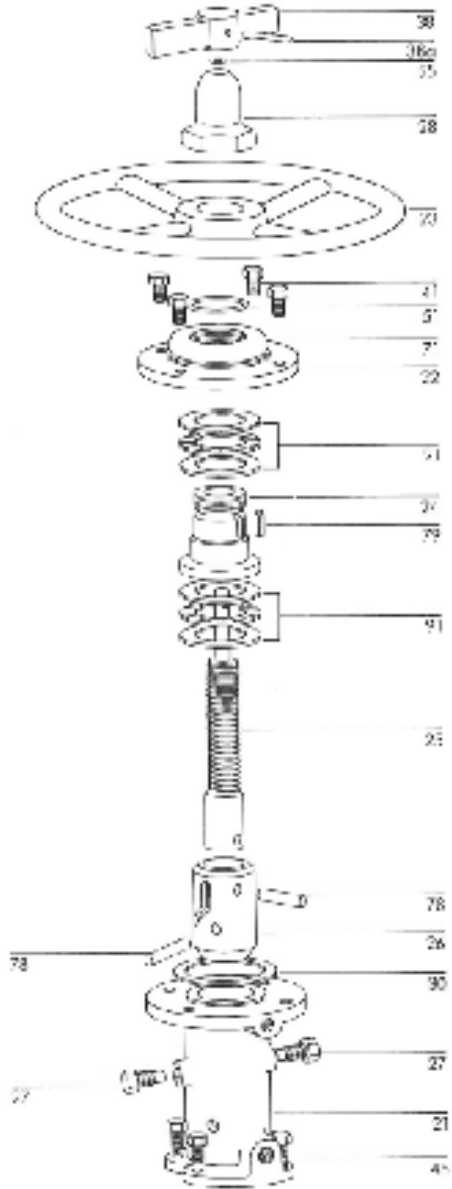

200 Series

No.	Description
21	Operator Housing
22	Bearing Cap
23	Handwheel
24	Drive Nut
25	Stem
26	Coupling Cam
27	Cam Pins
28	Dust Cap
30	Shim Set
38	Indicator Flag
38a	Indicator Flag Pin
41	Bearing Cap Bolt
45	Operator Housing Bolt
51	Bearing Cap O-Ring
56	Dust Cap O-Ring
78	Coupling Pins
79	Handwheel Key
91	Thrust Bearing Assembly
71	Grease Fitting (not shown)

400 Series

No.	Description
21	Operator Housing
22	Bearing Cap
23	Handwheel
24	Drive Cam
25	Stem
26	Coupling Cam
27	Cam Pins
38	Indicator Flag
38a	Indicator Flag Pin
39	Indicator Flag Rod
41	Bearing Cap Bolt
45	Operator Housing Bolt
55	Stem Seal O-Ring
63	Bearing Cap O-Ring
77	Coupling Pins
79	Handwheel Key
80	Handwheel Retaining Nut
91	Thrust Bearing
30	Shim Set (not shown)

400 Series Operator

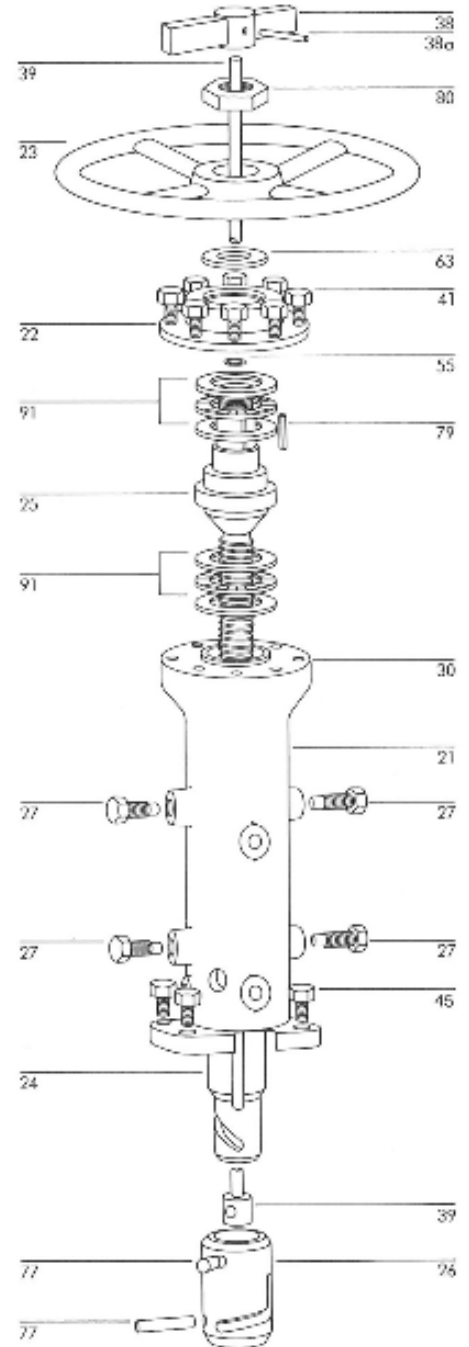

BLEED SYSTEMS

MANUAL BLEED VALVE¹ (MBV)

The simplest bleed valve for hand operated GENERAL VALVE TruSeal valves. When GENERAL VALVE TruSeal is closed, open body bleed valve to check drop tight sealing. Close MBV before opening the GENERAL VALVE TruSeal. Bleed outlet should be properly piped to suitable drainage sump.

Note: the "goose neck" pipe to prevent drainage of the body liquid.

THERMAL RELIEF TO BODY (TRB)**

With the GENERAL VALVE TruSeal closed the thermal relief valve releases any thermal expansion of the body liquid, back safely and automatically, to the line. Relief set at 25 psi.*

THERMAL RELIEF TO ATMOSPHERE (TRA),** (See Page 10)

Similar to TRB except thermal relief valve is set at 50 psi above pipeline rated pressure and is vented to atmosphere.

MANUAL BLEED VALVE¹ WITH THERMAL RELIEF (MTR)**

The manual bleed proves drop tight sealing. The Thermal Relief Valve releases any thermal expansion of the body liquid, back safely and automatically to the line. Relief set at 25 psi.*

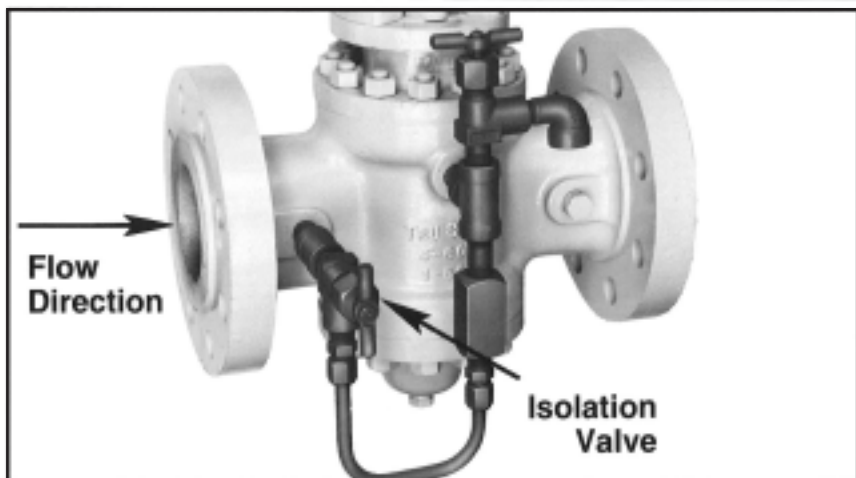
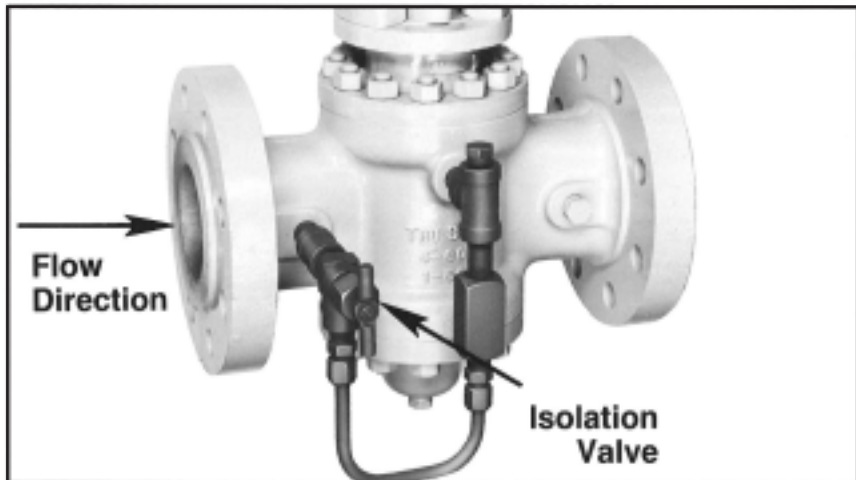
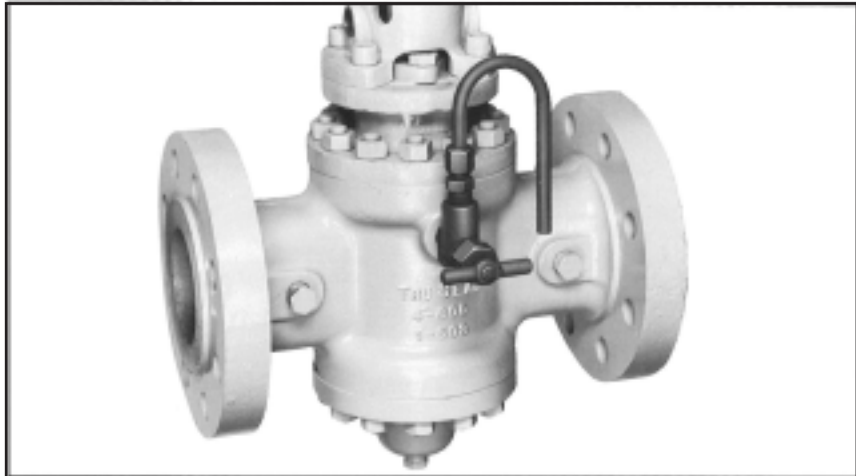

¹When a manual bleed or automatic bleed is fitted, the vent pipe should always be above the highest point of the valve body cavity. This will prevent liquid in the body cavity from dripping out. Leakage past either seal would expel liquid from the already-full body cavity.

*The relief valve is set to open at 25 psi on all valves, regardless of their working pressure. With the valve closed, the relief valve will open at 25 psi above upstream pressure. This system functions only when the GENERAL TRUSEAL valve is closed and the isolation valve is open.

CAUTION

A thermal relief system, piped back to the valve throat, converts the GENERAL VALVE TruSeal to a "DIRECTIONAL" valve. Thermal relief should always be piped back to the upstream side. If it were piped to the downstream, any leakage past the main seal on the "up" side would be permitted to by-pass the "down" seal, by way of the directional check valve.

BLEED SYSTEMS

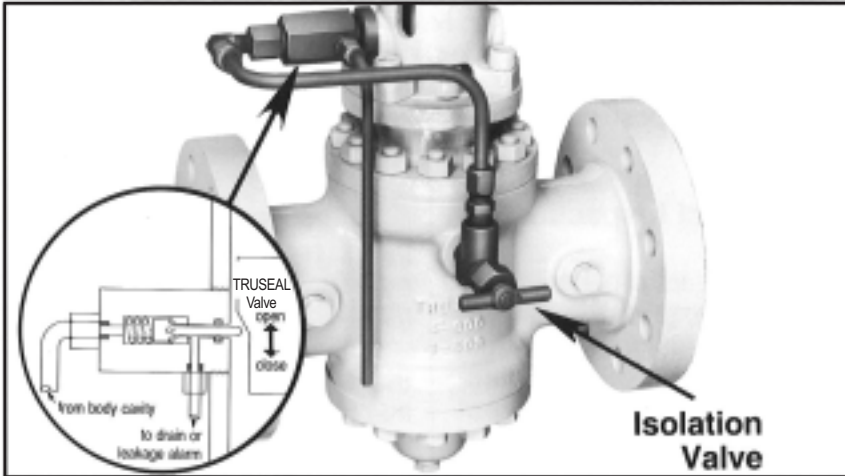

AUTOMATIC BODY BLEED VALVE¹ (ABV)

A plunger actuated check valve is opened by the coupling cam as the GENERAL VALVE TruSeal is closed (either manually or by power actuator). This system removes the human element from seal checking, making it completely automatic. The isolation valve may be padlocked "open" to ensure total double block and bleed integrity, avoiding any risk of human error in sealing verification.***

MANUAL BLEED VALVE¹ WITH GAUGE (MBG)

The manual bleed valve is combined with a gauge when emission to atmosphere is undesirable. The closing action of a GENERAL VALVE TruSeal valve automatically reduces body cavity pressure due to the expanding seating segments. The gauge alone will indicate tight seals. (After a period of time, body pressure may again increase due to thermal expansion of fluid in the body cavity).

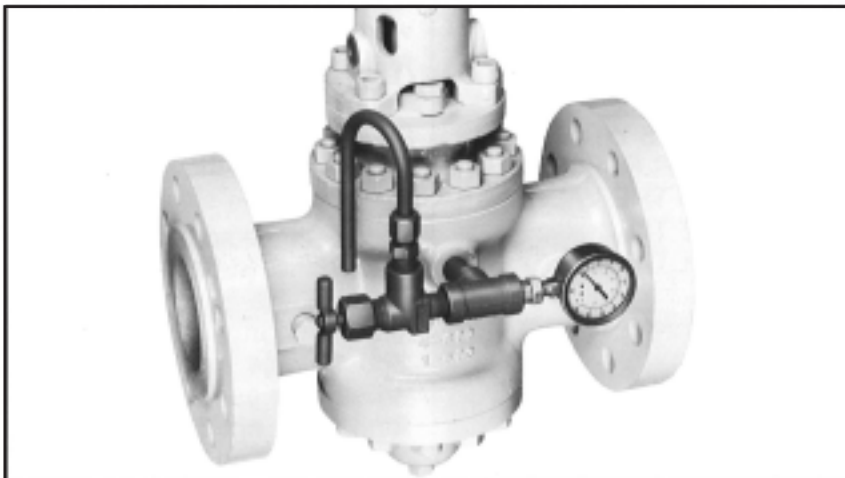

THERMAL RELIEF VALVE WITH GAUGE (TRG)**

A thermal relief valve, to relieve any body pressure which may build up due to thermal change, is combined with a gauge to indicate tight seals. No emissions to atmosphere. No sump system required. Relief set at 25 psi*.

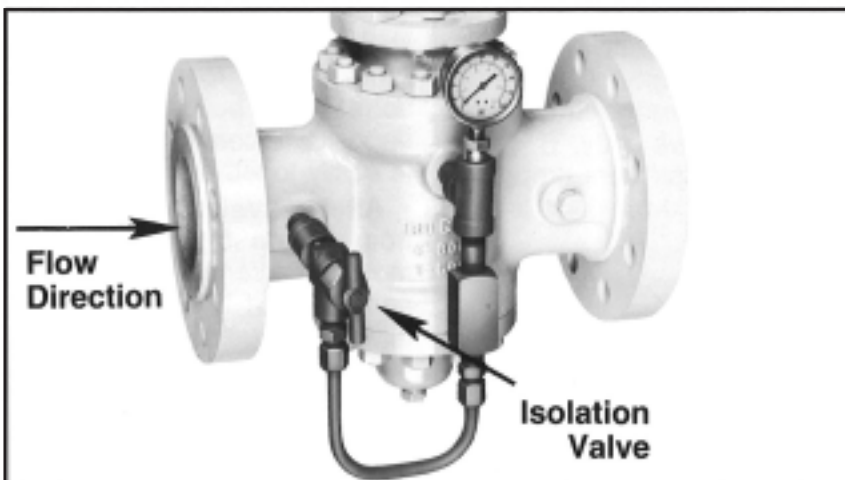

**Thermal relief systems are designed to relieve excess pressure rise in the body cavity of a closed valve due to ambient temperature causing expansion of the liquid in the valve.

*** Some fluid is emitted at each actuation. A sump system is important as fluid will spurt out as the GENERAL VALVE TruSeal approaches the closed position and the cam opens the ABV. The spurting will cease as GENERAL VALVE TruSeal is fully closed for positive verification of double sealing.

Note: All automated TruSeal valves require some form of body pressure relief. TRB/TRA/MTR/ABV/TRG

CAUTION

In normal service, the Manual Bleed is kept closed, unless to check for GENERAL VALVE TruSeal tightness or to vent thermal pressure rise. With automatic bleed or thermal relief back-to-line, the manual isolation valve that is attached to the GENERAL VALVE TruSeal body must always be open, except for maintenance. If the isolation valve is closed, the relief system cannot operate.

REPAIRS



LOWER PLATE REMOVAL

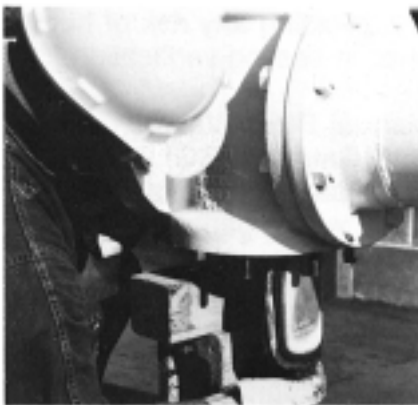

SUPPORT ONE SLIP, REMOVE THE OTHER



SEATING SLIPS

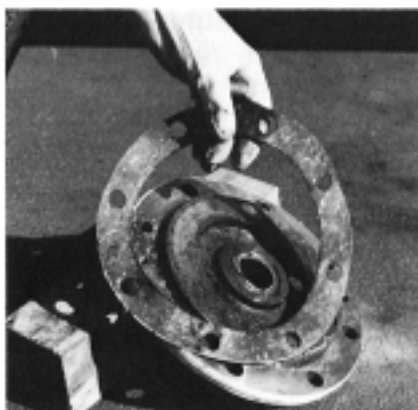

LOWER PLATE GASKET

These instructions are written assuming the valve is installed in a horizontal line, with plug stem vertical, handwheel above the pipeline. Should there be any difficulty interpreting these guidelines for other mounting positions, consult your nearest GENERAL VALVE TruSeal representative.

SEATING SEAL INSPECTION OR CHANGE

Seating seals are bonded to metal segments called "slips". Slips can be factory re-bonded, if the metal has not been damaged.

WARNING:

NEVER ATTEMPT TO CHANGE SLIPS WITH VALVE UNDER PRESSURE.

DAMAGE TO THE VALVE AND INJURY TO PERSONNEL COULD RESULT.

Leave the GENERAL VALVE TruSeal mounted in line, in the open position and drain the line before proceeding.

Check by means of the body bleed and lower plate drain, that the pipe is empty. Close the GENERAL VALVE TruSeal, to wedge the slips against the valve body. This will prevent the slips from dropping out when the lower plate is removed.

With support under the lower plate, remove the lower plate nuts (part no. 44) and the lower plate.

If necessary, use jack-bolts in the tapped holes provided for this purpose.

With support under the slips, turn the GENERAL VALVE TruSeal handwheel towards "open". Keep hands and feet out from under the slips.

The slips (part no. 5) will slide off the plug.

Be sure that the spaces left by removal of the slips are clean.

Inspect the seals for evidence of damage. Substitute with new slips if there is any cut or missing section in the soft seal.

Reassemble in reverse order.

Be sure to use a new body O-ring (part no. 52) and a new gasket (part no. 8).

Do not force any part. Slips should fit freely on plug dovetails.

Check for sediment or corrosion or build-up of foreign deposits, if components do not fit easily together.

Alternatively, slip removal from the top is possible, by removing the bonnet.

Consult your local Cameron representative for detailed instructions.

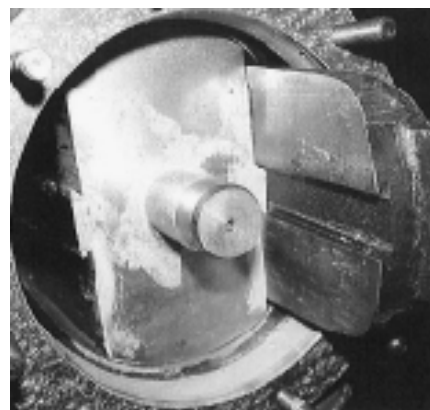

SLIPS FIT ON PLUG DOVETAILS

REPAIRS

CHANGING THE STEM PACKING

WARNING:

NEVER ATTEMPT TO CHANGE PACKING WITH VALVE UNDER PRESSURE.

DAMAGE TO THE VALVE AND INJURY TO PERSONNEL COULD RESULT.

If the packing is to be changed, the pipeline must be drained and checked by venting the body bleed. Only proceed after you are certain the valve and line do not contain pressure. Remove the operator as described in the next column. ("Operator Change").

Remove the packing gland bolts (part no. 42, Page 4).

Remove the packing gland (part no. 6).

Remove the V-packing set (part no. 61).

Carefully install new V-packing, one ring at a time, taking care that lips are not damaged and that lips face into the valve.

Install new gland O-rings (part no. 53 & 54) and scraper ring, if originally fitted.

Install packing gland and retaining bolts. Torque the bolts until the gland is tight, metal/metal, against the bonnet surface.

Install operator with coupling pin and fixing bolts.

Use only GENERAL VALVE TruSeal approved parts, as dimensions are critical to good operation.

CAM PIN CHANGE (See Page 12)
Worn or damaged cam pins (part no. 27) can cause the GENERAL VALVE TruSeal to malfunction, (i.e. stiff turning or failure to seal tight).

Remove one pin at a time, to inspect for wear or damage. Replace that pin before removing another cam pin, to avoid realignment difficulty of pins in their guide slots.

When installing cam pins, do not use excessive torque. The cam pins only require a "snug" metal-to-metal fit.

A slightly polished wear-spot is normal. Severe "D" shape, flat spot, or bending of the pin is not normal. Replace with a new cam pin if wear is evident and investigate the cause.

Use only genuine GENERAL VALVE TruSeal parts. Dimensions and material hardness are critical for good operation.

OPERATOR CHANGE OR REMOVAL

1. Close the GENERAL VALVE TruSeal valve.
2. Remove the yoke housing bolts (part no. 45, Page 13).
3. Drive out the lower coupling pin (part no. 77 or 78).
4. Lift off the whole operator.
5. Install an operator in reverse order.

CAUTION:

If the operator has been removed from a GENERAL VALVE TruSeal valve, the lower plate MUST NOT BE REMOVED without first ensuring that the plug is firmly held by its upper stem. There is a coupling hole through the upper stem, to which support may be attached.

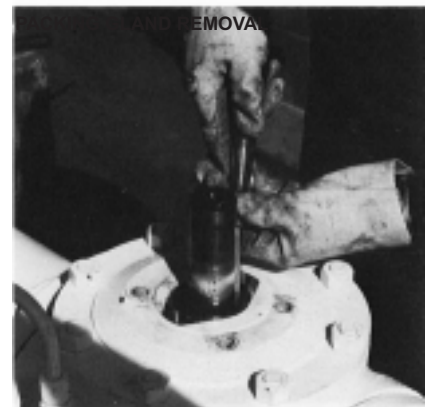

REPAIRS

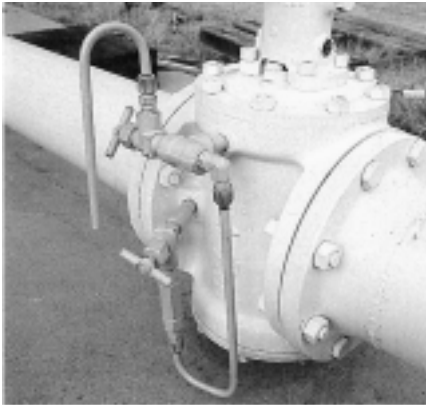

MANUAL BLEED WITH THERMAL RELIEF (MTR)



AUTOMATIC BLEED VALVE (ABV)



THERMAL RELIEF TO BODY (TRB)



THERMAL RELIEF TO ATMOSPHERE (TRA)

THERMAL RELIEF BLEED SYSTEM

(TRA, TRB, TRG or MTR - See pages 6-7).

Malfunction of the thermal relief system can be diagnosed if a manual bleed is also installed. If any dripping from the manual bleed is stopped by closing the isolation valve in the throat of the GENERAL TRUSEAL, then the GENERAL TRUSEAL elastomer seals are in good condition. The leak path is through the thermal relief system.

THERMAL RELIEF SYSTEM REPAIR

1. Close the GENERAL TRUSEAL isolation valve.
2. Open the manual bleed valve, (if fitted), to verify that line pressure is not present in the vent system. If no manual bleed has been fitted, line pressure must be removed from the pipeline before the relief couplings are loosened.
3. Close the isolation valve in the throat of the GENERAL TRUSEAL (if fitted),
4. Only proceed further when liquid run-off has stopped. The thermal relief element is now isolated and can be uncoupled from its pipework.
5. Clean out the relief valve or replace it with a new part. Check for tight sealing with an airline and soap bubble test before installation.
6. Reassemble the pipework, taking care to install the relief valve with the correct flow direction, FROM the body TO the line (TRB, TRG or MTR Assembly). FROM the body TO atmosphere (TRA Assembly).

AUTOMATIC BLEED VALVE (ABV) - REPLACEMENT

If it is necessary to remove the ABV, first close the GENERAL TRUSEAL. Verify that the body pressure has vented by observing discharge from the bleed drain pipe. Close the isolation valve on the body cavity and then disconnect the bleed pipes from the ABV.

Loosen the locknut on the ABV and unscrew the ABV body from the operator housing. Clean it or replace it with a new ABV. To reinstall the ABV, screw the ABV into the operator housing until the plunger-end just touches the cam. Blow through the ABV ports and continue to turn the ABV to find the point where the seat begins to lift. Then rotate the ABV an additional 1/2 turn clockwise and tighten the locknut.

Reconnect the bleed lines to the ABV and open the isolation valve on the body cavity.

Cycle the GENERAL TRUSEAL open and closed to check for proper operation of the ABV. A spurt of liquid should come from the ABV drain pipe just before the GENERAL TRUSEAL reaches "fully closed".



AUTOMATIC BLEED WITH SIGHT GLASS

FIELD SERVICE GUIDE

OBSERVATION
LEAKAGE FROM BODY BLEED

(GENERAL TRUSEAL valve in CLOSED position)

SUGGESTED PROCEDURE

- 1 Check for the possibility that the GENERAL TRUSEAL valve is not fully closed. Do not use excessive force to close, as this may cause damage to the GENERAL X05X0Á; Û^æ body.
- 2 The dripping may be due to thermal expansion of the liquid or trapped vapor in the valve body, caused by temperature rise. If this is the case, leakage will stop when temperature stabilizes.
- 3 If a thermal relief and manual bleed system is fitted, venting back to the line, isolate the relief valve by closing the manual isolation valve in the GENERAL X05X0Á; Û^æ throat. If leakage from the manual bleed stops, refer to instructions for the repair of a thermal relief system on page 10.
- 4 Close the body bleed, then fully open and close the GENERAL X05X0Á; Û^æ two or three times to flush out any dirt that may have accumulated in the valve.
- 5 If none of the above procedures stop the leakage, remove the seating slips. (See instructions on page 8). Inspect for accumulated dirt or ice, or damage to the soft seals. Inspect the spaces left by the removal of the slips to ensure they are clean. If the seals are cut or damaged, replace with new slips. Install the cleaned or new slips and fit a new gasket and body O-ring before replacing the lower plate.

OBSERVATION
LEAKAGE FROM AUTOMATIC BLEED VALVE (ABV)

(GENERAL TRUSEAL valve in OPEN position)

SUGGESTED PROCEDURE

- 1 Close the isolation valve on the GENERAL X05X0Á; Û^æ body.
- 2 Check to see if the plunger of the ABV is free to move. A screwdriver blade can be inserted through the cut-out hole in some operators to depress the ABV plunger. Otherwise, continue with steps 3-5 below.
- 3 Open the isolation valve on the GENERAL X05X0Á; Û^æ body.
- 4 Stroke the GENERAL X05X0Á; Û^æ open and closed two or three times to flush out any dirt that may have accumulated in the ABV seal area.
- 5 If the ABV still does not operate properly, remove the ABV and clean or replace it. Refer to instructions on page 10.

OBSERVATION
GENERAL TRUSEAL VALVE WILL NOT OPEN

(DO NOT USE EXCESSIVE FORCE!)

SUGGESTED PROCEDURE

- 1 Check for a "pressure lock" condition by venting the body cavity, relieving excess pressure.
- 2 If a thermal relief is fitted, check that the isolation valve on the throat of the GENERAL X05X0Á; Û^æ is open, allowing the thermal relief system to operate.
- 3 Drive out the coupling pin (part no. 77 or 78). Try to actuate the operator only. If the handwheel still does not move, there is a problem with the operator mechanism. Read the instructions on operator inspection, page 13. If the handwheel moves easily, the stiffness is in the valve body section.
- 4 Remove line pressure and vent the GENERAL X05X0Á; Û^æ body cavity pressure. Refit the coupling pin. Remove the yoke housing bolts (part no. 45), the flag indicator (part no. 38) and the cam pins (part no. 27). Now turning the handwheel will lift the operator housing upwards, exposing the packing gland. Lift the housing enough to allow a wrench to fit onto the packing gland bolts. Loosen the packing gland bolts one turn. Reassemble the operator and turn the handwheel. If it now moves easily, the stiffness could have been caused by excessive swelling of the stem packing, resulting in the tight gripping of the plug stem. Consult Cameron for advice on suitable stem packing material, if packing swelling appears to be a problem. Do not restore line pressure to the valve until the packing gland bolts are tightened.
- 5 If there is no release of stiffness, the valve must be isolated from service. Remove the lower plate and slips (refer to instructions on page 8) to determine the cause of the stiffness inside the valve body. See "CAUTION", page 9.

FIELD SERVICE GUIDE

C6 G9 F J5 H C B

; 9 B 9 F 5 @ J 5 @ 9

H F I G 9 5 @ J 5 @ 9

K @ @ B C H ' 7 @ C G 9

(DO NOT USE
EXCESSIVE FORCE!)

SUGGESTED PROCEDURE

- 1 Remove the operator yoke housing bolts (part no 45). If handwheel rotation now causes the housing to lift upwards easily, then the operator is functioning correctly. If the operator handwheel does not rotate easily, then skip to procedure number 8.
- 2 Look for stiffness in the body section. Restore the bolts to the yoke housing, then follow the seal inspection instruction on page 8. Omit the instruction to close the valve. Take special care to support the weight of the lower plate and slips, as lower plate nuts are removed.
- 3 Look for dirt accumulated below the plug that could prevent downward movement.
- 4 Look for compacted sand and pipe-scale on the face of the seating slips that could prevent the soft seals from touching the body.
- 5 Look for accumulated sand or scale or ice in the trunnion hole of the lower plate.
- 6 Look for corrosion or excessive deposits of hard material in the dovetail region between slips and plug. Remove any deposits with a wire brush and investigate the cause of the deposit.
- 7 Look for blockage of the relief holes in plug trunnion bushing (part no. 7, page 4).
- 8 If the removal of yoke housing bolts (in section 1 this page), did not free the handwheel movement, do not remove the operator, or the plug may drop while in the "Open" position. With the operator still mounted on the valve, follow the instructions for "Operator Inspection", page 13, to determine the cause of stiffness.

CAUTION:
WHEN DISMANTLING ANY MECHANICAL ASSEMBLY, TAKE CARE TO KEEP HANDS AWAY FROM ANY PARTS THAT MAY SUDDENLY MOVE WHEN THE RETAINING FORCE IS REMOVED. USE SUPPORTS FOR ANY PARTS THAT COULD MOVE.



OPERATOR BOLTS REMOVED HOUSING LIFTED



CAM PIN REMOVAL



CAM PIN INSPECTION



PACKING GLAND BOLTS EXPOSED



VALVE WITH OPERATOR REMOVED



COUPLING PIN REMOVAL

OPERATOR INSPECTION

Operators can be safely removed from GENERAL XCSXOAVI™ valves while the pipeline system is under full rated pressure and the valve is in the closed position.

If the Field Service Procedures indicate a stiffness in the operator, follow this sequence of inspections until the problem is identified.

- 1 Look for ice, dirt, or foreign objects that may interfere with free movement.
- 2 Remove the cam pins (part no. 27) one at a time and inspect for damage or excessive wear. See information on cam pin change on page 9. Replace each pin before removing another one.
- 3 Replace with new pins if necessary and investigate the cause of damage. Excessive force at the handwheel may be the cause.
- 4 Remove the handwheel and bearing assembly from the top of the operator. Take special care when slackening thrust bearing retainer bolts (part no. 41), in case the bearing is under a load condition. Check that the threads of the stem (part no. 25) turn freely in the matching threads of the drive nut or cam (part no. 24). If there has been any thread damage, replace both stem and drive nut or cam.
- 5 Inspect thrust bearing (part no.91) for possible damage. Replace if necessary.
- 6 Gear housing, stem threads and guide pin slots are grease packed during manufacture. Re-packing with grease, after dismantling, is required.
- 7 When the operator has been removed from a GENERAL XCSXOAVI™ valve, the lower plate MUST NOT BE REMOVED without first ensuring that the plug is firmly held by its upper stem. There is a coupling hole through the upper stem, to which support may be attached.

200 Series Operator

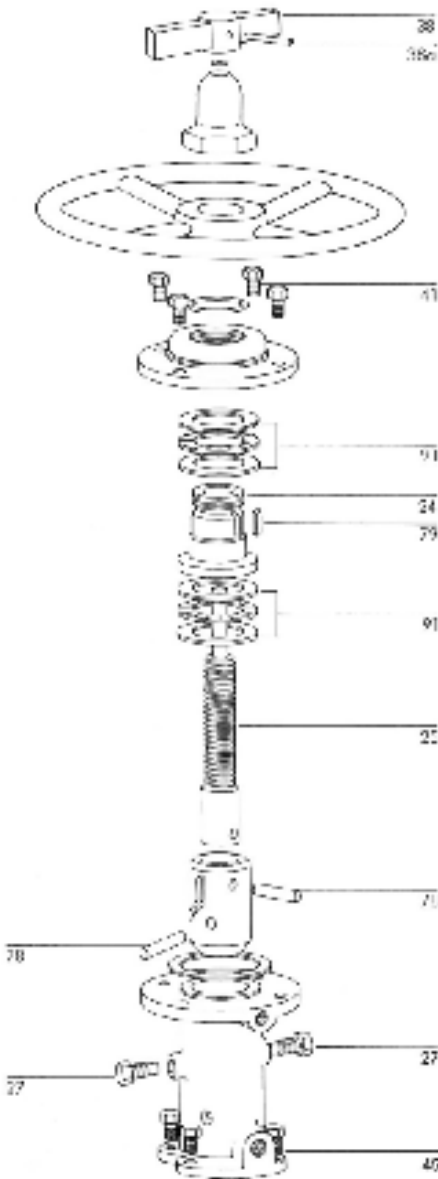

400 Series Operator

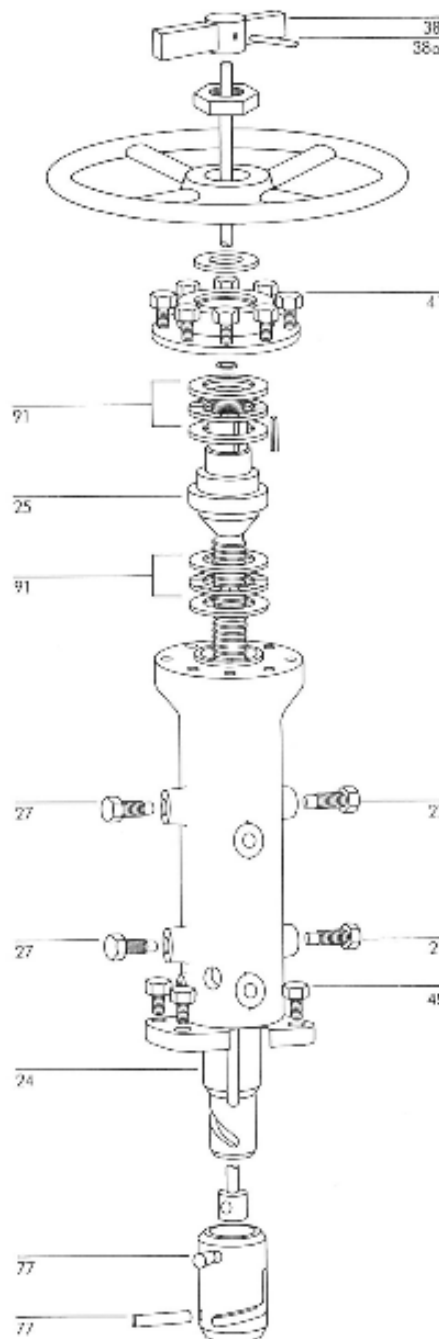

Contact your Cameron's Valves & Measurement group representative for a Repair Manual



3250 Briarpark Drive, Suite 300
Houston, Texas 77042
USA Tel 281 499 8511

For the more information on GENERAL VALVE: www.c-a-m.com/GENERALVALVE

© Cameron's Valves & Measurement Group Printed in Canada Revised 10/07-NP-3M IOM-GEN-TRUSEAL