

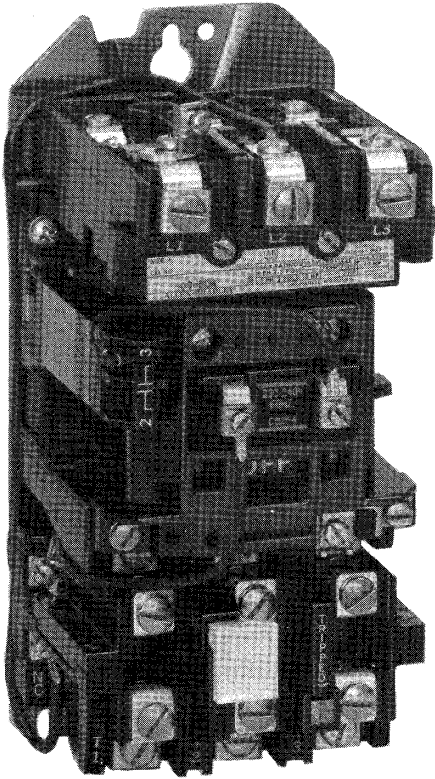

ALLEN-BRADLEY

Typical Wiring Diagrams



Bulletin 509
Full Voltage Starter

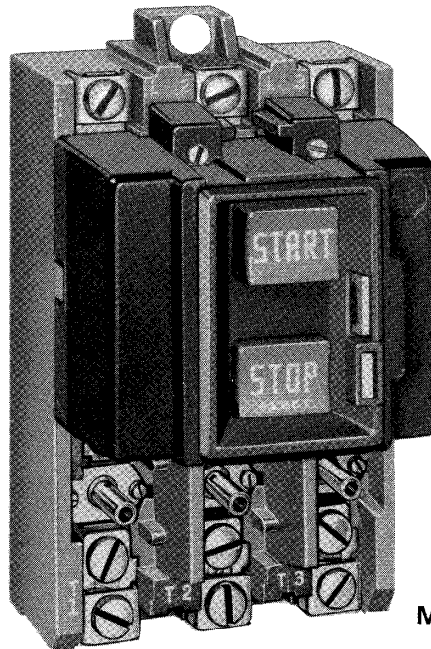

Bulletin 609
Manual Starting Switch

Manual and Magnetic Full Voltage Starters



i n t r o d u c t i o n

This booklet has been prepared as a guide to some of the useful ways Allen-Bradley's manual and magnetic across-the-line starters may be applied. It will also serve as a useful aid where simple wiring systems are to be studied.

When applying these diagrams, it is well to remember that the features described in several diagrams may be combined into one to produce another useful way of applying Allen-Bradley equipment. As you become familiar with the diagrams, most such changes will prove simple. Exercises of this kind will be extremely beneficial to a student's better understanding of motor control wiring diagrams. **It is important to note:** A particular application must satisfy the needs of the user and comply with applicable codes, laws and standards before using any of the typical circuits shown in this publication.

The symbols used in this booklet were adopted by Allen-Bradley for use in all its publications. They are in accordance with NEMA standards.

The Allen-Bradley Company is very interested in helping engineers, electricians and students to a better understanding of motor control equipment. It is our hope that this booklet furthers this purpose.

c o n t e n t s















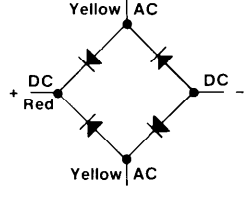

	PLATE	PAGE
Introduction		2
Wiring Diagram Symbols		4
Common and Important Terms		6
Bulletin 600 Manual Single Phase Starters	1 thru 4	7
Bulletin 609 Manual Starters	5 thru 13	8
Bulletin 509 Magnetic Full Voltage Starters		11
Three-Phase Starters	14 thru 17	12
Single-Phase Using 3-Phase Starter	18 and 19	14
Variations With START-STOP Stations	20 thru 24	15
Step-Down Transformer in Controls Circuits ...	25	18
Jogging	26 and 27	19
Two-Wire Control Circuits	28 thru 32	20
Pump Operation (Backspin and Surge Protection)	33 and 34	23
Sequence Control	35 thru 37	24
Bulletin 505 Magnetic Reversing Starter		26
Three-Phase Starters	38 and 39	27
Push Button Variations	40 thru 44	28
Jogging	45	31
Plugging	46 and 47	32
Anti-plugging	48	34
Bulletin 520 Multi-Speed Motor Starters	49 thru 51	35

Key to Symbols

Shown here are the symbols most often used in this book. Although the explanations accompanying the diagrams describe the devices used, familiarity with the various symbols will lead to a quicker understanding of each circuit.

The symbols, device designations, and abbreviations in this book are taken from the NEMA Standard Publication/No. ICS-1-1978.

Wiring Diagram Symbols

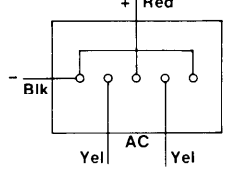
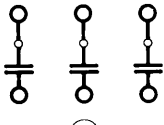
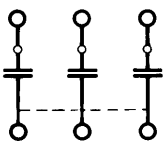
Device		Symbol		Device		Symbol			
Coils	Relay and Switch Coils	 Single Winding	 Tapped	Fuse	General				
		 Permanent Magnet	 Economized			Indicating Lights	General	NE - Neon FL - Fluorescent  P - Purple OP - Opalescent O - Orange A - Amber B - Blue C - Clear G - Green R - Red W - White Y - Yellow	
Contacts	Normally Closed (N.C.)	 Main	 Auxiliary	Motors	3 Phase Squirrel Cage Induction				
	Normally Open (N.O.)	 Main	 Auxiliary					Single Phase	
	Time Closing	 N.O.T.C.	 N.C.T.C.	Rectifier	Full Wave with Color Code				 Yellow AC + DC Red DC - Yellow AC
	Time Opening	 N.C.T.O.	 N.O.T.O.			 + Red - Blk Yel AC Yel			
Contactors	AC Solenoid Type	 3 Pole							
	Manually Operated								

Device		Symbol	Device		Symbol													
Relays	Control	<p>(P400 Shown)</p>	Switches	Plugging														
	Thermal Overload			Pressure and Temperature	<p>Closing On Rising Press. Opening On Rising Press.</p> <p>Closing On Rising Temp. Opening On Rising Temp.</p>													
	Timing (Pneumatic) (ON-DELAY)			Push Button Standard														
	Anti-Plugging			Push Button Heavy Duty, Oiltight	<p>Mushroom Head</p>													
Switches	Float Switch	<p>Normally Open</p> <p>Normally Closed</p>	Push Button and Jog Attachment															
	Limit Switches	<p>Normally Open</p> <p>Normally Closed</p> <p>Held Closed</p> <p>Held Open</p>	Standard Duty Selector Switch															
	Potential		Heavy Duty Selector 2-Position	<table border="1"> <thead> <tr> <th rowspan="2">Letter Sym.</th> <th colspan="2">Position</th> </tr> <tr> <th>1</th> <th>2</th> </tr> </thead> <tbody> <tr> <td>A</td> <td>X</td> <td></td> </tr> <tr> <td>B</td> <td></td> <td>X</td> </tr> </tbody> </table>	Letter Sym.	Position		1	2	A	X		B		X			
	Letter Sym.	Position																
1		2																
A	X																	
B		X																
Current	<p>Line Side Load Side</p> <p>Polarity Mark</p>	Heavy Duty Selector 3-Position	<table border="1"> <thead> <tr> <th rowspan="2">Letter Sym.</th> <th colspan="3">Position</th> </tr> <tr> <th>1</th> <th>2</th> <th>3</th> </tr> </thead> <tbody> <tr> <td>A</td> <td></td> <td></td> <td>X</td> </tr> <tr> <td>B</td> <td>X</td> <td></td> <td></td> </tr> </tbody> </table>	Letter Sym.	Position			1	2	3	A			X	B	X		
Letter Sym.	Position																	
	1	2	3															
A			X															
B	X																	
Transformer																		

SOME COMMON and IMPORTANT TERMS

In this booklet, and wherever motor control is discussed, there are several terms which are used repeatedly but whose meanings are often not completely understood by the reader. These terms represent things which are actually quite simple and everyone should become familiar with them as standard "motor control jargon."

UNDERVOLTAGE RELEASE Also Called: Low-Voltage Release Two-Wire Control

These terms mean that the starter will drop out when there is a voltage failure and will pick up again as soon as voltage returns. Reference to the diagram below will show how this occurs. The pilot device is unaffected by the loss of voltage and its contact remains closed, ready to carry current as soon as line voltage returns to normal.

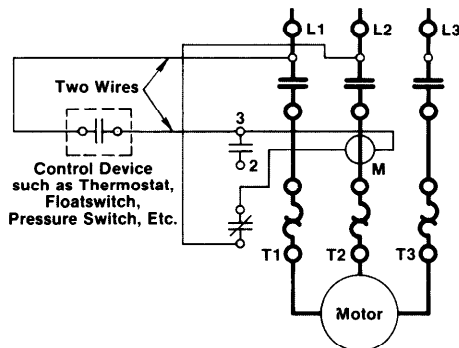

Two wires lead from the pilot device to the starter. "Undervoltage release" and "two-wire control" should bring to mind an automatic pilot device such as a limit switch or float switch whose function is opening and closing the control circuit by means of a single contact.

UNDERVOLTAGE PROTECTION Also Called: Low-Voltage Protection Three-Wire Control

These terms mean that the starter will drop out when there is a voltage failure but will not pick up automatically when voltage returns. The control circuit is completed through the STOP button and also through a "holding" contact (2-3) on the starter. When the starter drops out, this contact opens, breaking the control circuit until the START button is pressed once again.

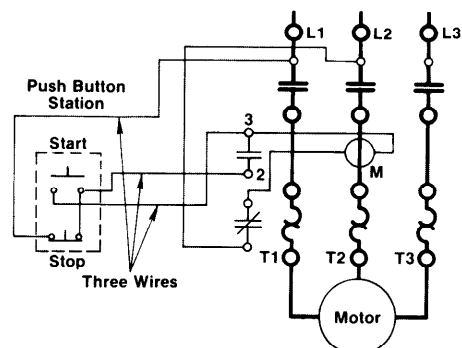

Three wires lead from the pilot device to the starter. "Undervoltage protection" and "three-wire" control should bring to mind a START-STOP push button station which is the most common means of providing this type of control.

The main distinction between the above two types of control is that with **undervoltage release** the coil circuit is maintained through the pilot switch contact, and with **undervoltage protection** it is maintained through a "stop" contact on the push button station and also an auxiliary contact on the starter. The designations "two-wire" and "three-wire" are used only because they describe the simplest applications of the two types. Actually, in other systems, there might be more wires leading from pilot device to starter but the principle of "two-wire" or "three-wire" control would still be present.

"WIRING DIAGRAMS" vs "LINE DIAGRAMS"

Most of the diagrams in this book are shown in two ways. There is a "wiring diagram" and adjacent to it a "line diagram." Line diagrams are included because their use is becoming more widespread and we believe it is advantageous to learn to use them.

Wiring diagrams or connection diagrams include all of the devices in the system and show their physical relation to each other. All poles, terminals, coils, etc. are shown in their proper place on each device. These diagrams are helpful in wiring-up systems, because connections can be made exactly as they are shown on the diagram. In following the electrical sequence of any circuit, however, the wiring diagram does not show the connections in a manner that can be easily followed. For this reason a rearrangement of the circuit elements to form a line diagram is desirable.

The **line diagram** (sometimes referred to as an **elementary diagram** or a **schematic diagram**) is a representation of the system showing it in the simplest

way. No attempt is made to show the various devices in their actual relative positions. All control devices are shown between vertical lines which represent the source of control power, and circuits are shown connected as directly as possible from one of these lines to the other. All connections are made in such a way that the functioning of the various devices can be easily traced. **Note:** In this publication the line diagrams show the control circuits only — power circuits are omitted for clarity, since they can be traced readily on the wiring diagrams (heavy lines).

A **wiring diagram** gives the necessary information for actually wiring-up a group of control devices or for physically tracing wires when trouble-shooting is necessary. A **line diagram** gives the necessary information for easily following the operation of the various devices in the circuit. It is a great aid in trouble-shooting as it shows, in a simple way, the effect that opening or closing various contacts has on other devices in the circuit.

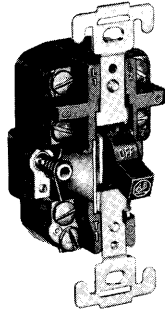

Bulletin 600 manual starting switches are designed for starting and protecting small AC and DC motors rated at 1 HP or less where undervoltage protection is not needed. They are operated by a toggle lever mounted on the front of the switch. Wiring diagrams do not show the operating mechanism since it is not electrically controlled.

These motor starters consist of an "ON-OFF" snap switch combined with a thermal overload device operating on the eutectic alloy ratchet principle. Terminal markings corresponding to those shown on the diagrams will be found on each switch.

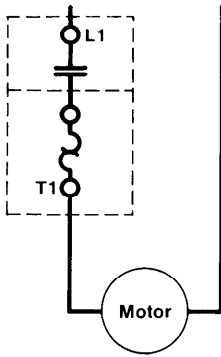

Catalog No. 600-TAX4

Single pole switches can be used wherever the electrical requirements permit only one motor line to be broken.

1

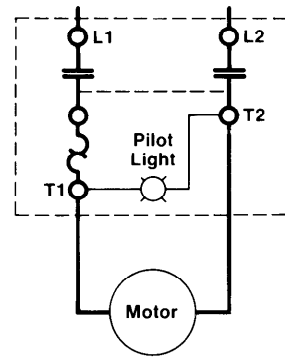

Catalog No. 600-TAX109

Double pole switch with built-in Neon pilot light to indicate when switch is on.

2

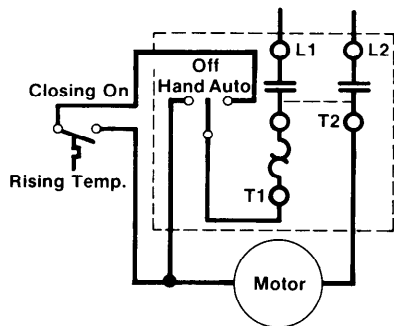

Catalog No. 600-TAX9

For use with automatic pilot devices such as thermostats, and float switches. A selector switch is mounted in the same enclosure to allow manual operation of the automatically controlled equipment.

3

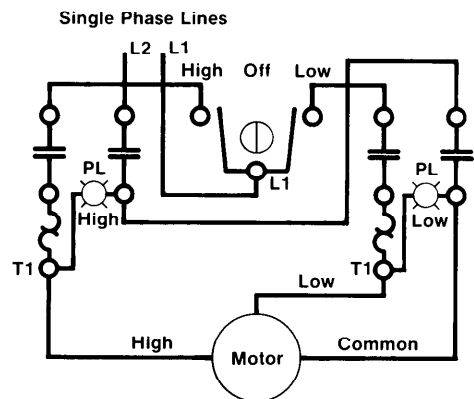

Catalog No. 600-TAX293

Two speed manual motor starter is designed for starting and protecting small, single phase, two-speed AC fan motors.

4

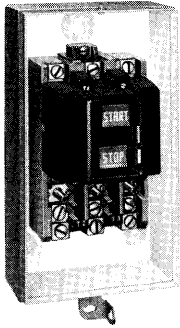

Bulletin 609 manual starters are operated by "START-STOP" push buttons mounted on the front of the starter. They are used in applications which do not require undervoltage protection. Wiring diagrams do not show the operating mechanism since it is not electrically controlled. Pushing the "START" button mechanically closes the contacts, connecting the motor to the line. The contacts are opened by pressing the "STOP" button. Terminal markings corresponding to those shown on the diagrams will be found on each switch.

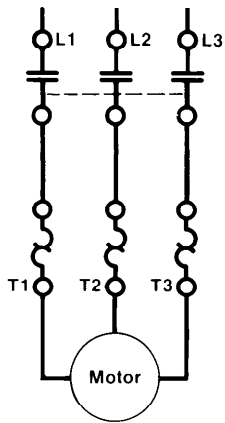

Sizes 0 & 1

3 Phase or 2 Phase, 3 Wire

(For 2 Phase, 3 Wire, L2 and T2 are common)

5

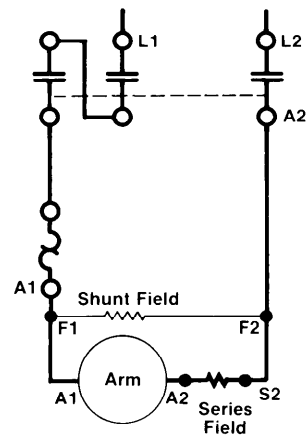

Sizes 0 and 1

Direct Current

6

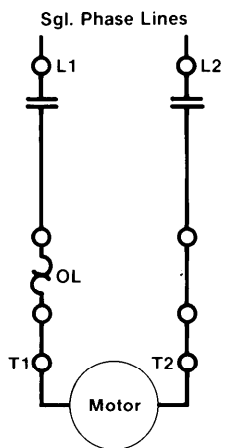

Sizes 0, 1 and 1P

Single Phase

7

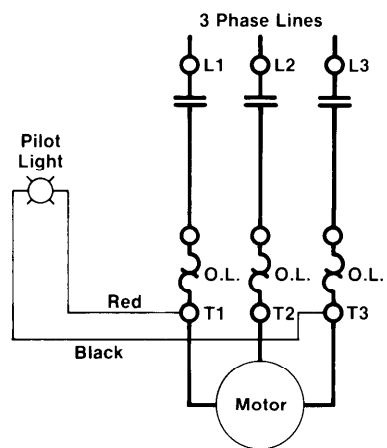

Sizes 0 & 1

3 Phase With Pilot Light

8

The Bulletin 609RS manual reversing starters and the Bulletin 609TS manual two-speed starters consist of two standard Bulletin 609 starters mounted in a single enclosure. Internal wiring of these starters provides the necessary connections for interchanging two motor connections in the case of the 609RS or switching to another winding in the case of the 609TS. Bulletin 609TS is for two-speed separate winding motors only. Terminal markings corresponding to those shown on the diagrams will be found on each switch.

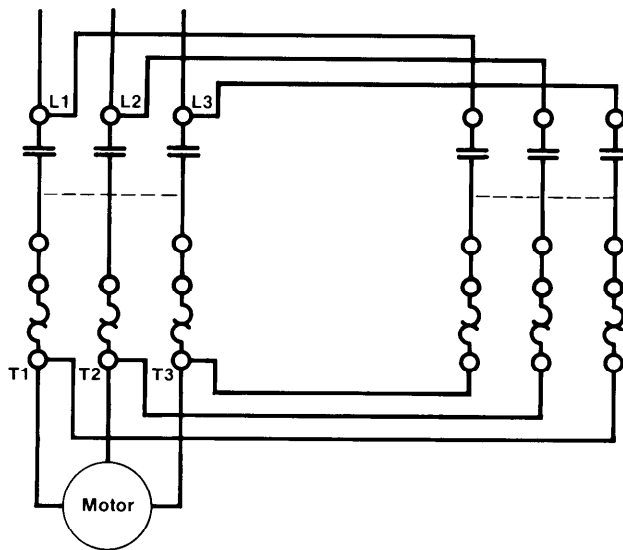
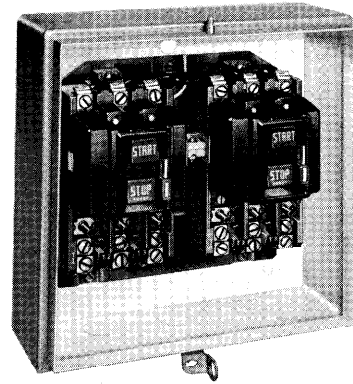

Reversing Starter

Bulletin 609RS

Sizes 0 & 1

3 Phase
2 Phase, 3 Wire

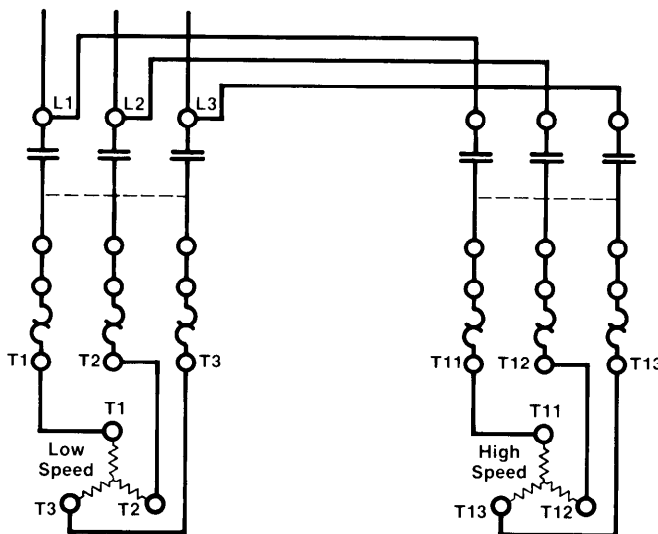

Two-Speed Starter

Bulletin 609TS

Sizes 0 & 1

3 Phase
2 Phase, 3 Wire

(For separate winding motors only)

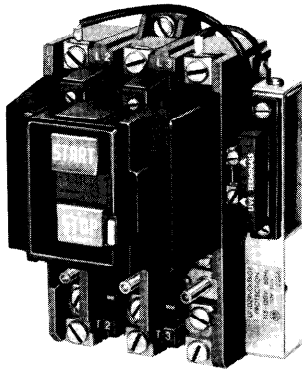

The Bulletins 609U and 609TU are the same as the standard Bulletin 609 Manual Starters except for the addition of Undervoltage Protection. These starters provide full line voltage starting, reliable thermal overload protection, as well as Undervoltage Protection. Typical applications are on woodworking machinery, metal sawing machines, and many other machine tools where Undervoltage Protection is needed to meet safety standards.

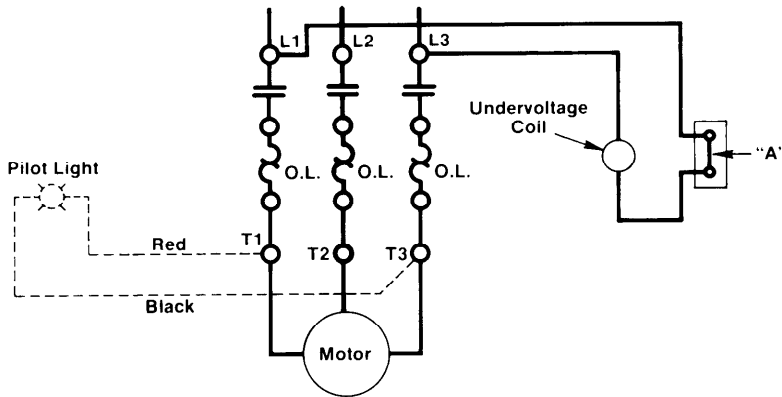

Sizes 0, 1 and 1P

3 Phase

Remove jumper "A" to connect remote emergency stop operator wires to vacated terminals. **Note:** The remote stop terminal block and jumpers are not available on devices in NEMA Type 7 and 9 enclosures.

11

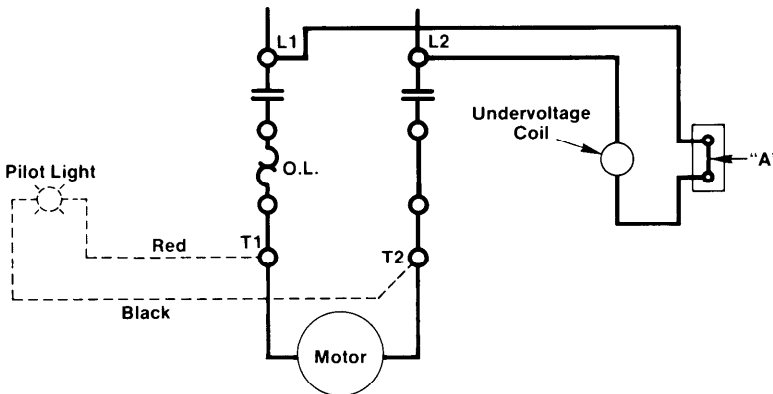

Sizes 0, 1 and 1P

Single Phase

Remove jumper "A" to connect remote emergency stop operator wires to vacated terminals. **Note:** The remote stop terminal block and jumpers are not available on devices in NEMA Type 7 and 9 enclosures.

12

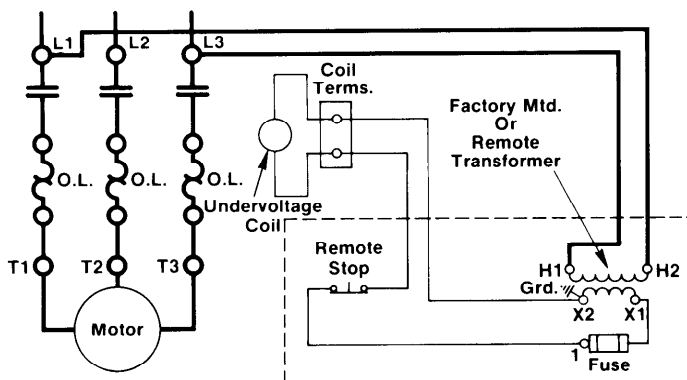

Sizes 0, 1 and 1P

3 Phase With 120 Volt Separate Coil
These starters must be properly applied with a remote control transformer to provide undervoltage protection. Connect transformer primary to the line side of the starter and the 120 volt secondary to the undervoltage coil as shown in the diagram.

13

THE BULLETIN 509 AS REPRESENTED BY A WIRING DIAGRAM

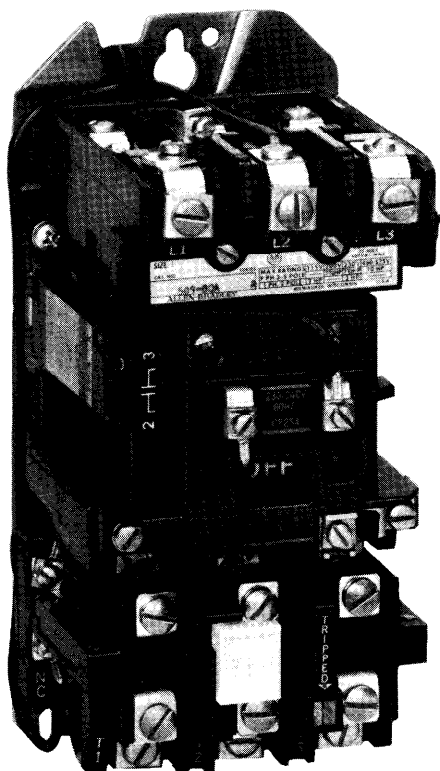

Bulletin 509 Starter, Size 1

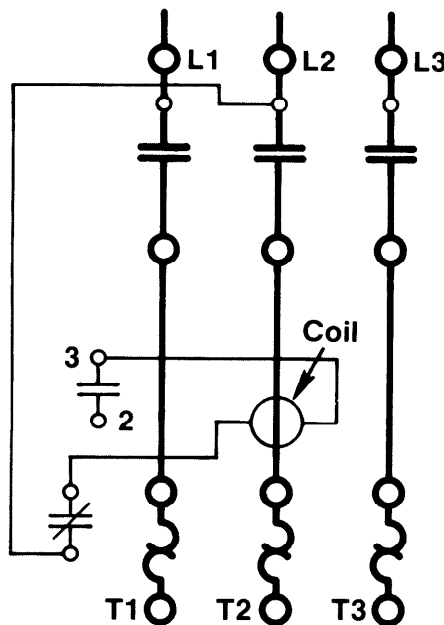

Wiring Diagram For
Bulletin 509 Starter, Size 1

Comparison of the picture and drawing shown above should help the reader become familiar with the Allen-Bradley Bulletin 509 starter as it is represented in wiring diagram form. Principal corresponding parts are labeled so that the wiring diagram can be compared with the actual starter. This should aid in visualizing the starter when studying a wiring diagram and will help in making connections when it is actually wired up. Note that the wiring diagram shows as many parts as possible in their proper relative positions. It is not necessary to show the armature and crossbar or the overload reset mechanism in the wiring diagram since these parts need not be considered from the wiring standpoint.

The Size 1 starter is shown here because all of the special wiring diagrams in this booklet use Size 1 starters as examples. The other sizes of starters have a similar appearance as the Size 1 and their principle of operation is the same. Wiring of the other sizes of starters is the same as for Size 1 although some of the connections are not physically located in the same places as on the Size 1.

3-Phase Starters

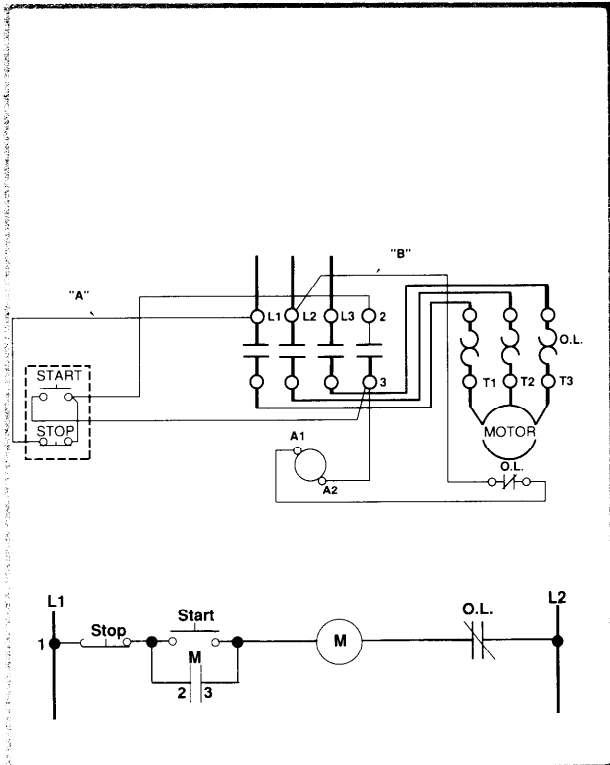

**Bulletin 509
 Size 00**

Standard wiring with START-STOP push button station

14

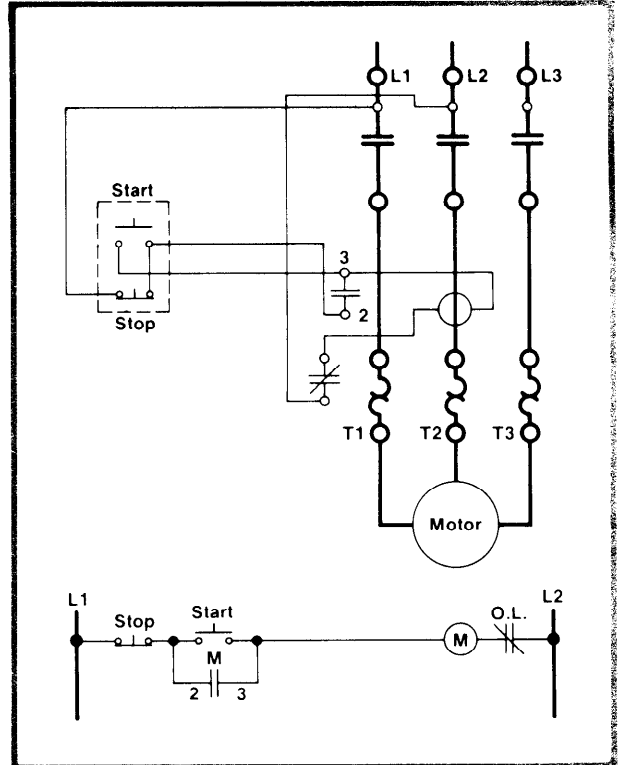

**Bulletin 509
 Sizes 0, 1, 2, 3 & 4**

Standard wiring with START-STOP push button station

15

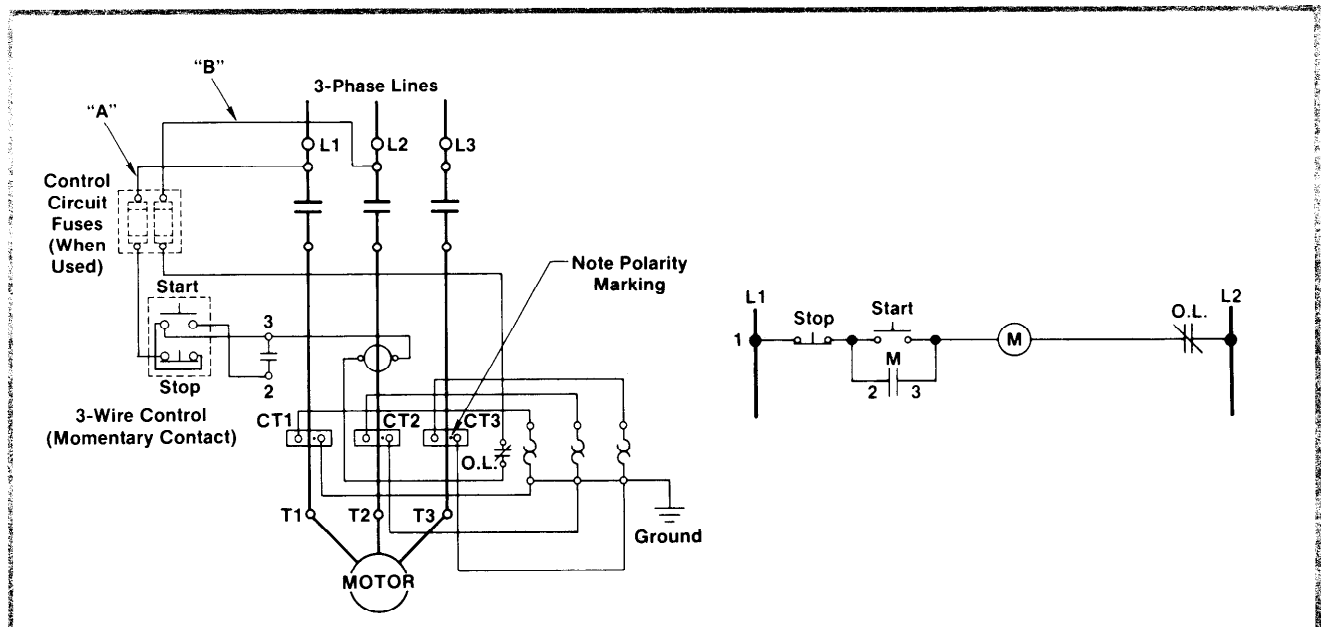

**Bulletin 509
 Size 5**

Standard wiring with START-STOP push button station. Current transformers are utilized thereby allowing the use of Size 1 overload relays.

16

Single Phase Using Standard 3-Phase Starters

Sizes 0, 1, 2, 3, & 4
 Standard wiring with START-STOP push button station.

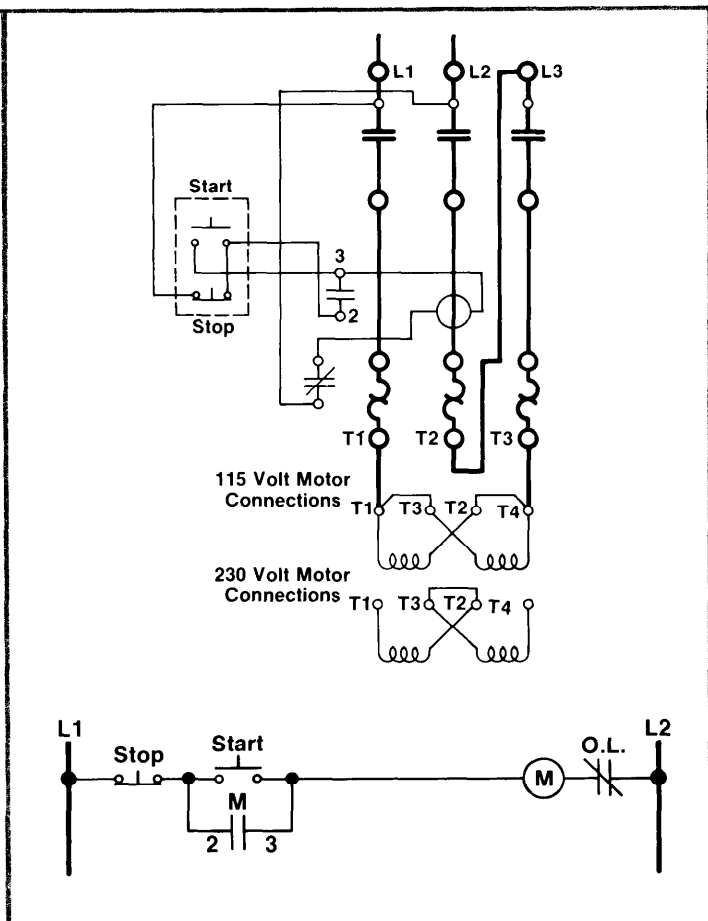

Variations with START-STOP Stations

More Than One START-STOP Station Used to Control a Single Starter

This is a useful arrangement when a motor must be started and stopped from any of several widely separated locations.

Notice that it would also be possible to use only one "START-STOP" station and have several "STOP" buttons at different locations to serve as emergency stops.

Standard duty "START-STOP" stations are provided with the connections "A" shown in the adjacent diagram. This connection must be removed from all but one of the "START-STOP" stations used.

Heavy duty and oiltight push button stations can also be used but they do not have the wiring connection "A", so it must be added to one of the stations.

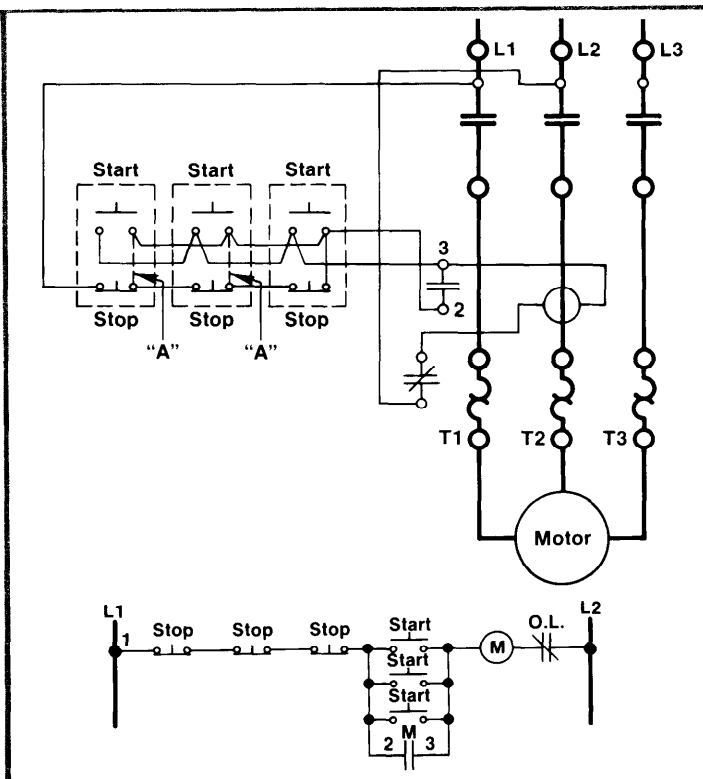

Variations With START-STOP Stations

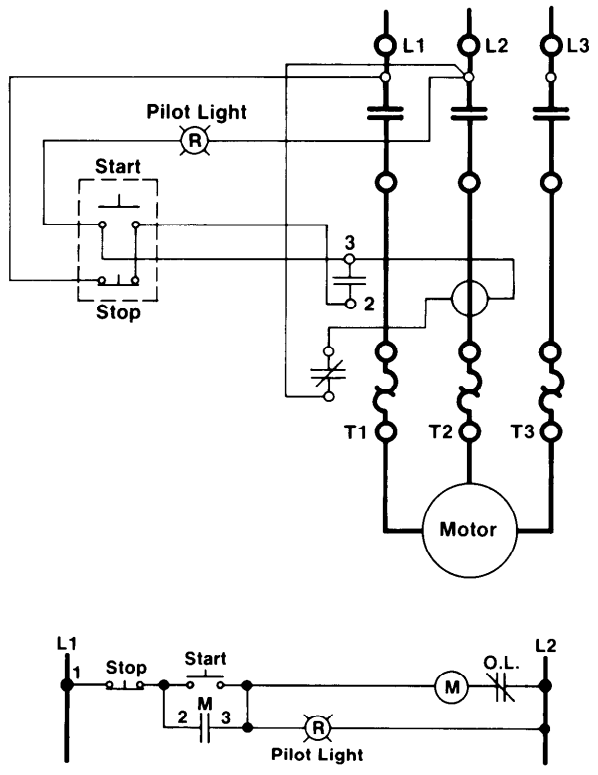

START-STOP Station with Pilot Light to Indicate When Starter is Energized.

A pilot light is to be used with a three-wire "START-STOP" station, so that it will be on when the starter is energized.

The light is shown here as separately mounted, but it can be combined in the same enclosure with the start and stop buttons. Stations combining all three are:

Type of Station	Catalog Number
Standard Duty	
120 or 240 V	800S-2SAP
Heavy Duty	
120 V	800H-2HAR
240 V	800H-2HAP
480 V, 60 Hz	800H-2HAY
600 V, 60 Hz	800H-2HAV
Oilight	
120 V	800T-2TAR
240 V	800T-2TAP
480 V	800T-2TAY
600 V	800T-2TAV

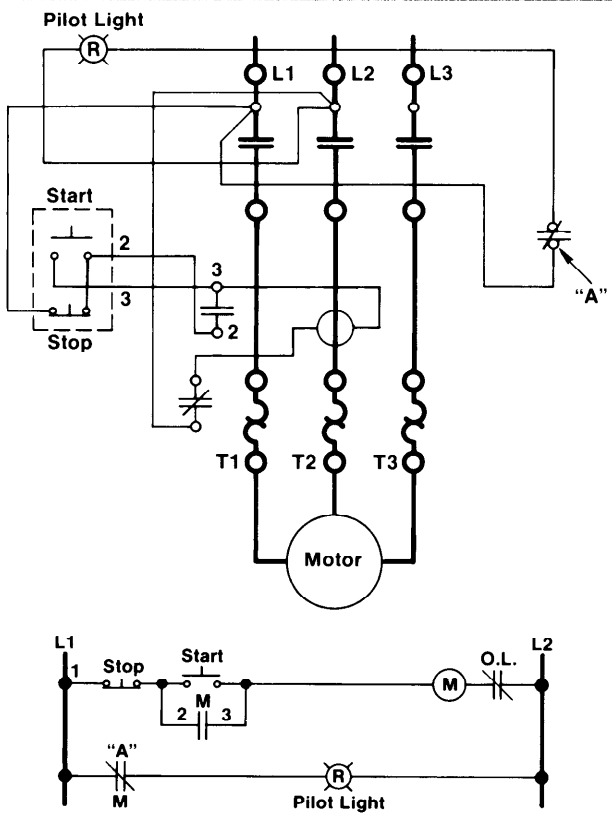

Station with Pilot Light to Indicate When Starter is Deenergized.

If it is necessary for a pilot light to show when the starter is de-energized, this requirement is most easily fulfilled by attaching a normally closed **Bulletin 595 auxiliary contact** to the starter and connecting it between L1 and L2 in series with the pilot light. "A" represents the Bulletin 595 auxiliary contact which can be added to any Allen-Bradley Bulletin 500 Line starter, sizes 0 through 4.

If the pilot light is to be included in the same enclosure with the start and stop buttons, any of the push button stations listed with drawing No. 20 can be used. The Bulletin 595 auxiliary contact has many other uses besides the ones shown here. It can also be used to operate other control circuit devices, interlock starters, etc.

Variations With START-STOP Stations

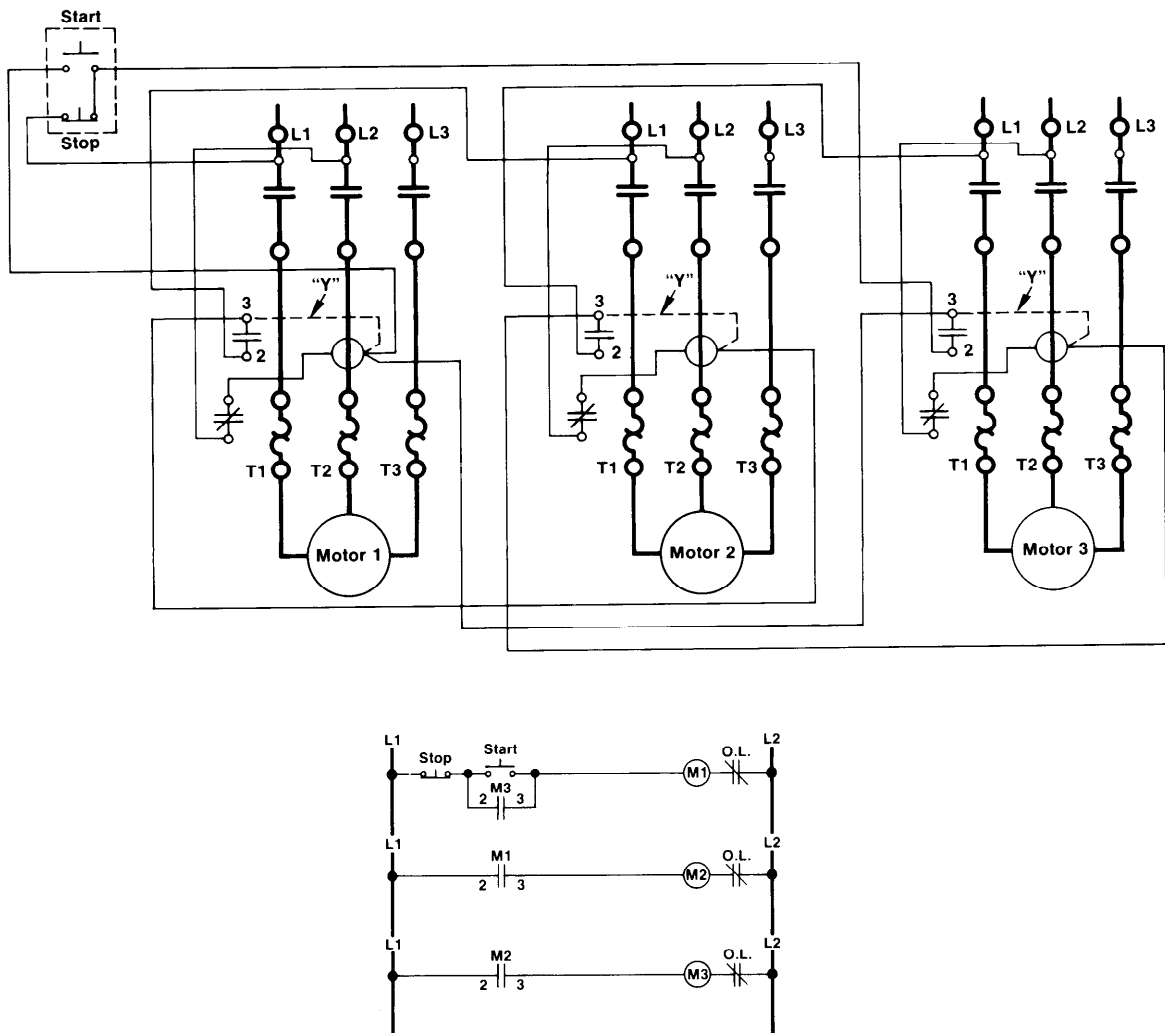

Three Starters are Operated from a Single "START-STOP" Station. An Overload on Any One of the Motors will Drop Out All Three Starters

Three Bulletin 509 solenoid type starters are to be connected so that all are controlled from a single "START-STOP" push button station. A maintained overload on any motor, tripping out the overload relays on its respective starter, will drop out all three starters disconnecting all motors from the line.

Assuming that standard Bulletin 509, Form 2 starters are to be used, then in order to obtain the desired operation, the wiring connection "Y" must be removed from each starter. The control circuits of the several starters are interconnected. It is therefore necessary to disconnect the power to the line terminals of **all** the starters in order to completely disconnect the equipment from line voltage.

Variations With START-STOP Stations

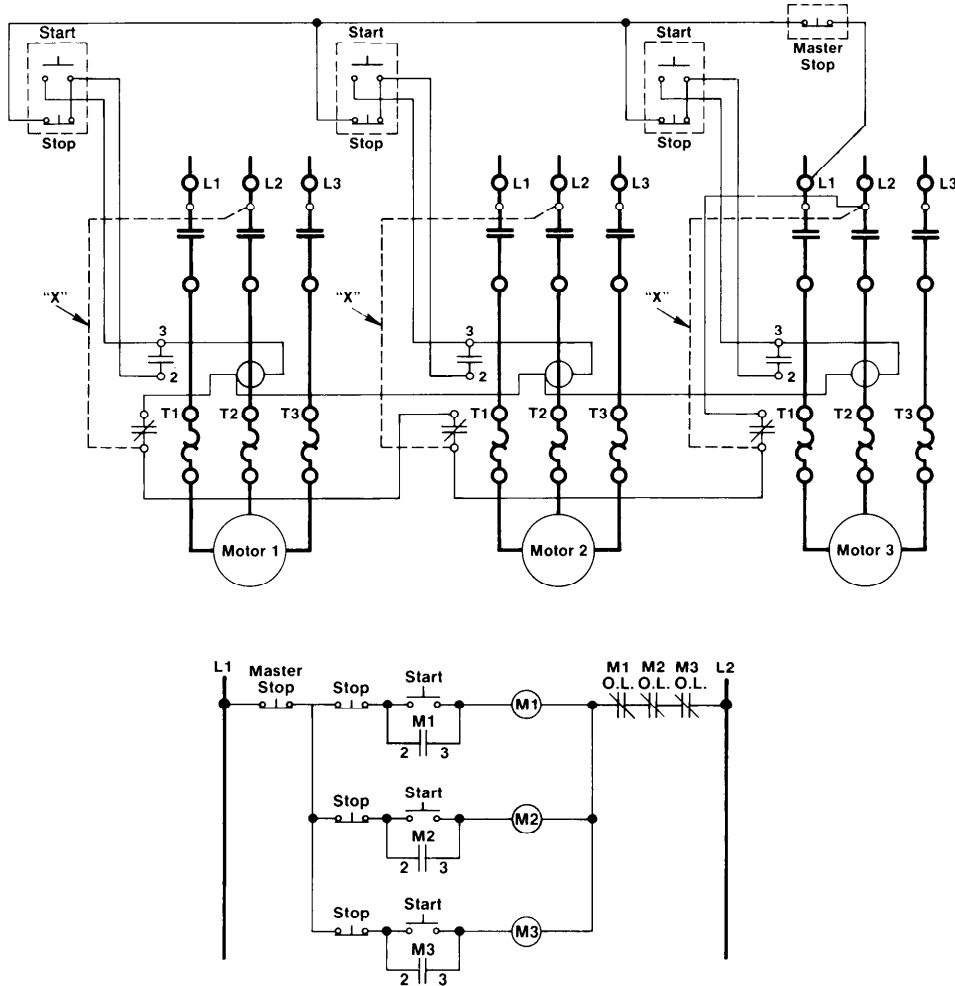

Each Starter is Operated by Its Own "START-STOP" Station. Overload on One Drops Out All Starters. A Master "STOP" Station Can Be Provided

Several starters (3 used in diagram) are to be wired so that each starter is operated from its own "START-STOP" push button station. However, a maintained overload, tripping a relay on any one of the starters, will automatically drop out all of the starters. A master "STOP" station wired into the circuit as illustrated will trip out all starters when pushed.

To obtain the desired operation using standard Bulletin 509 Form 2 starters, wire "X" must be removed from all but one of the starters. The control circuits of the several starters are interconnected. It is therefore necessary to disconnect the power to the terminals of **all** the starters in order to completely disconnect the equipment from line voltage.

Variations With START-STOP Stations

Two Starters are to Be Operated from a Single Station, But a Short Delay Must Prevent Them from Being Energized Together

In some cases, the power distribution system does not have sufficient capacity to start several motors simultaneously. If several motors are to be started from the same push button station under these conditions a time delay can be provided between the operation of the motor starters.

When the START button is pushed, the first starter is energized along with a timing relay. When the timing relay times out, it operates a contact which closes the control circuit of the second starter. (The timer can be a Bulletin 849.)

If more than two starters are to be used, additional timers will have to be added in the same way as the one shown connected to M1 here.

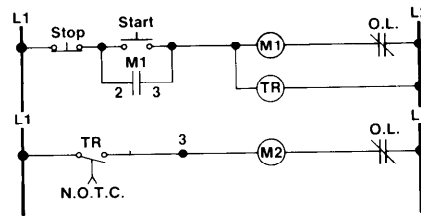
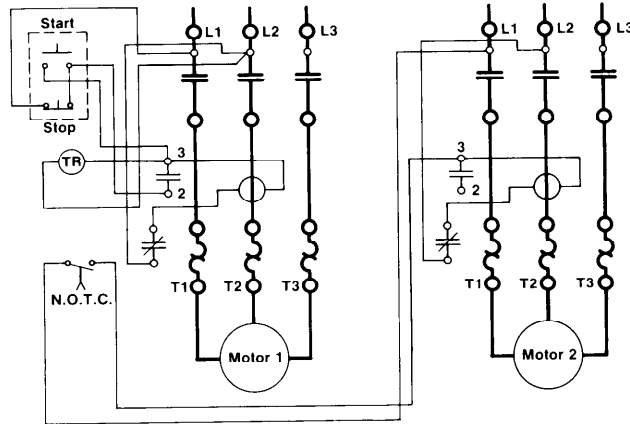

Step-Down Transformer in Control Circuit

Step-Down Transformer Provides Low Voltage for Control Circuit Wired for Three-Wire Control

The starter coil is to be operated on a voltage lower than line voltage. (Usually done for safety reasons.) This requires the use of a stepdown transformer in the pilot circuit. The starter is operated from a "START-STOP" push button station, either Bulletin 800S, 800H or 800T.

When a control circuit step-down transformer is used with a standard Bulletin 509 starter, the wiring connection "X" must be removed. Note that a fuse is added to the transformer secondary.

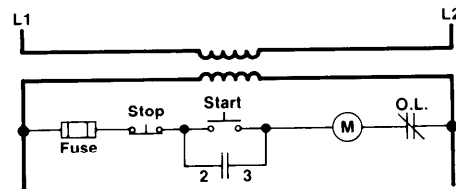
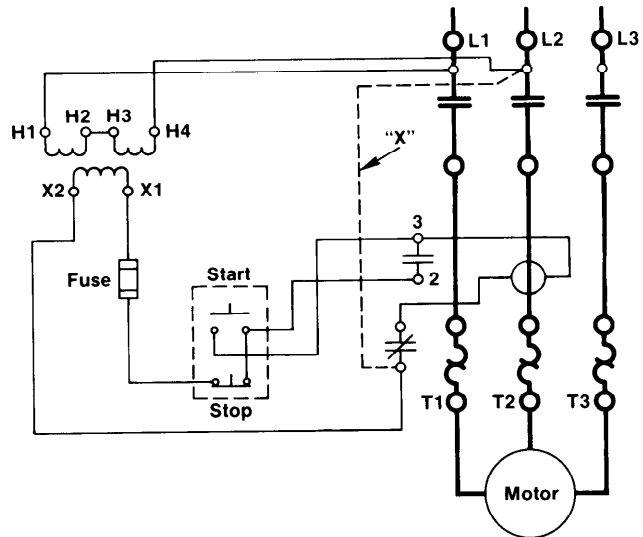

Jogging

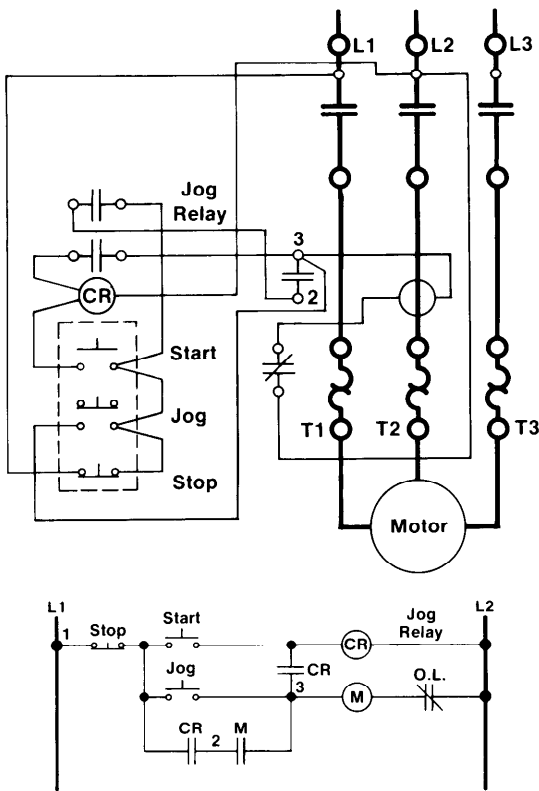

Separate "START-STOP-JOG" with Standard Push Buttons and a JOG Relay

The Bulletin 509 starter is to be operated by a "START-JOG-STOP" push button station.

The purpose of jogging is to have the motor operate only as long as the "JOG" button is held down. The starter must not "lock in" during jogging, and for this reason the "jog relay" is used.

Pushing the "START" button operates the jog relay, causing the starter to lock in through one of the relay contacts. When the "JOG" button is pressed, the starter operates, but this time the relay is not energized and thus the starter will not lock in.

CR represents the "jog relay," a Catalog Number 700-C200.

For a surface mounted heavy duty "START-JOG-STOP" station, specify Catalog Number 800H-3HG. A Catalog Number 800T-3TG can also be used.

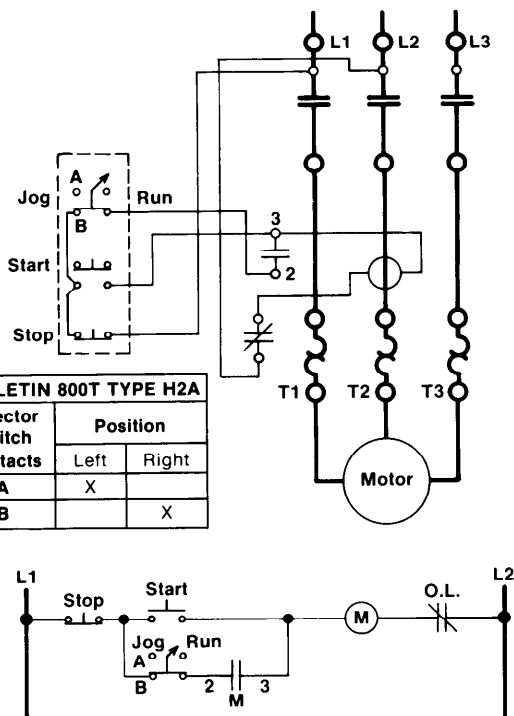

Combined "START, JOG" and Separate "STOP" With Selector Switch Jogging With a Selector Switch

Here, a three-unit push button station with a START-STOP and selector switch is used. Heavy duty station is Catalog Number 800H-3HW14 and oiltight Catalog Number is 800T-3TW15.

The circuit to the hold-in contact "M" is broken when the selector is in the "JOG" position. The "START" button is used to "JOG" or "RUN" the motor, depending on the position of the selector switch.

BULLETIN 800T TYPE H2A		
Selector Switch Contacts	Position	
	Left	Right
A	X	
B		X

Two-Wire Control Circuits

Starter Operated by Pressure Switch or Thermostat with Manual Control Provided by a Selector Switch. High Pressure Cut-Out Switch Can be Added

The selector switch feature can be obtained as part of the starter.

The selector switch makes it possible to operate the starter manually for testing or in case of failure of the automatic pilot control. When a standard Bulletin 509 across-the-line starter without push buttons is used, connection "Y" is removed and the wiring follows the solid lines of the diagram.

If a "high pressure" cut-out switch is added, it should be inserted in the line leading from L1 to the "HAND" terminal of the selector switch.

"A" represents the thermostat or "low pressure" switch and "B" represents the "high pressure" cut-out or "safety" switch.

For the "HAND-OFF-AUTO" selector switch, either a Catalog Number 800T-R3SX (standard duty), a Catalog Number 800H-R3HA (heavy duty), or a Catalog Number 800T-R3TA (oiltight) can be used.

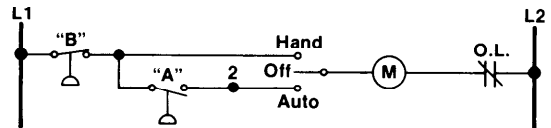
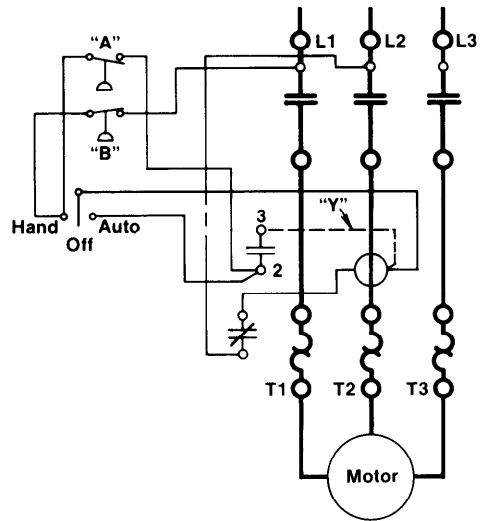

Two-Wire Control with Control Relay Added to Provide Under Voltage Protection

Undervoltage protection is often necessary when two-wire control is used in a location where line disturbances are frequent. Since the two-wire pilot device is not affected by loss of voltage, its contact will remain closed even though there is no power on the line. This means that without the feature of undervoltage protection, repeated voltage dips would cause the starter to "chatter" and welding of contacts might result.

Undervoltage protection can be added to improve safety, where automatic restarting after a power outage is hazardous.

If a voltage failure relay is added, it will open the pilot circuit at a bad voltage dip or power outage and will not permit the starter to close again until the relay has been reset.

"A" represents the two-wire pilot device.

The reset button, can be a Catalog Number 800H-1HG (heavy duty) or a Catalog Number 800T-1TG (oiltight).

CR represents the voltage failure relay. A Catalog Number 700-C200 relay can be used.

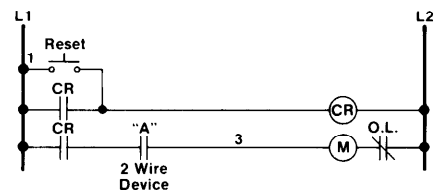
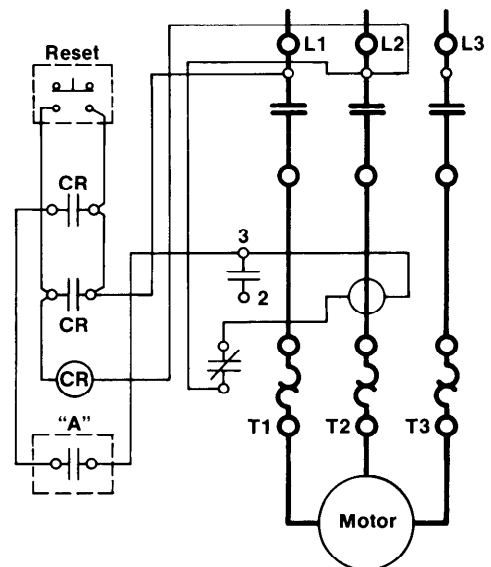

Two-Wire Control Circuits

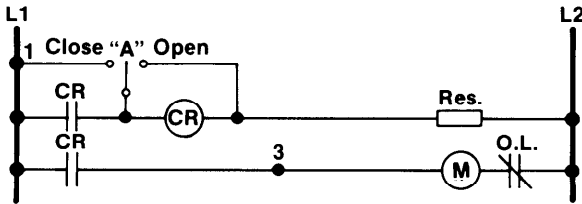
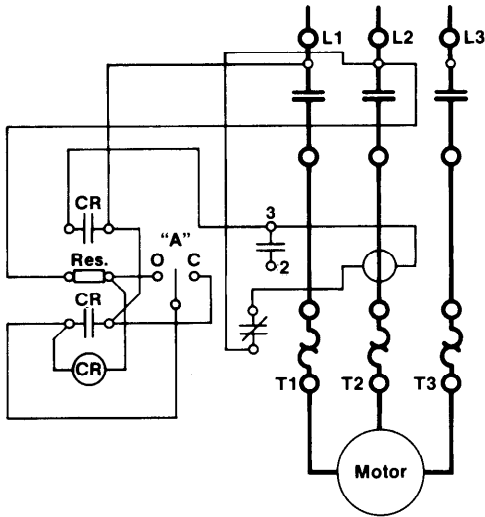

Starter is Controlled by a Gauge-Type Thermostat

Since the contacts of a thermostat of this type usually cannot handle the current to a starter coil, a "thermostat relay" must be used as an intermediate step between thermostat and starter. The relay is energized when the "CLOSE" contact is made and de-energized when the "OPEN" contact is made. The "OPEN" contact by-passes the relay coil to de-energize it. A resistor, built into the relay, guards against a short circuit when this is done.

The thermostat contacts must not overlap or be adjusted too close to one another, since this may burn out the resistance unit. It is also advisable to check the inrush current of the relay against the current rating of the thermostat. This scheme can also be used with pressure controls.

"A" represents the three-wire gauge type temperature control device.

CR represents the thermostat relay. A Catalog Number 700-BA200 can be used here.

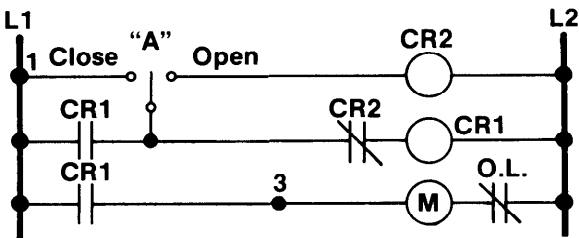
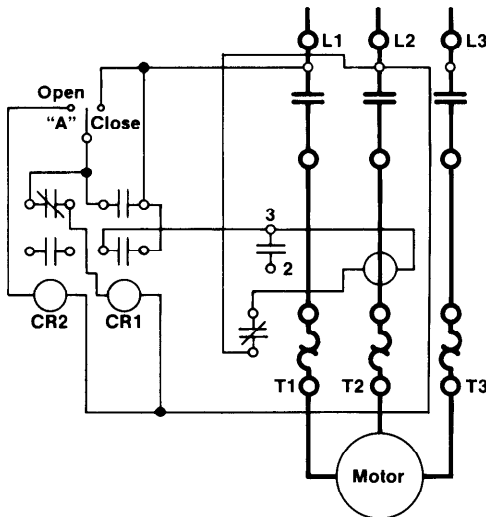

Starter is Controlled by a Gauge-Type Thermostat Whose Contacts Can Switch Only a Small Amount of Current

Here is another method of protecting thermostat contacts from high current. This scheme, however, is for use with a thermostat whose contacts can handle even less current than the ones in the previous example.

In a case like this, it is advisable to use relays having coils which operate at a very small value of volt-amperes. This will reduce the burden on the thermostat contacts and is especially advisable where frequent operation is required. "A" represents the three-wire sensitive gauge type control.

CR1 and CR2 represent low coil current relays, Catalog Numbers 700-CL200 and 700-CL110, respectively.

Two-Wire Control Circuits

Float Switch Controls Starter

The diagram shows a float switch intended for tank operation. When the water reaches "low" level the float switch closes. Pumping action will continue until the water reaches "high" level.

For sump pumping remove wire "A" and connect as per the dotted line. At "low" level the float switch operates and stops the pumping action. Sump pumping action will not commence until the water reaches "high" level.

A Bulletin 840 Float Switch with an appropriate float switch accessory may be used for this application.

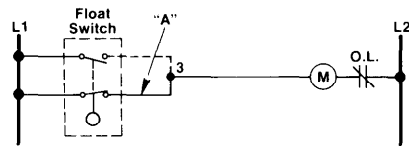
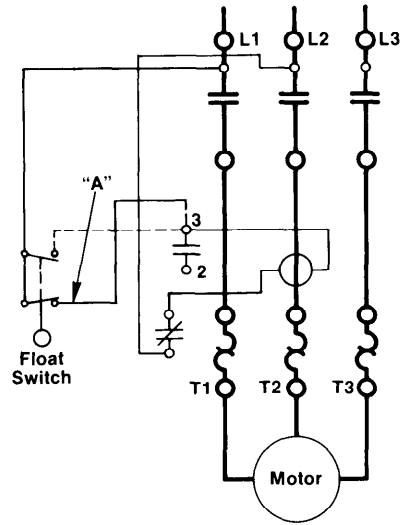

Pump Operation

Surge Protection is often necessary when the pump is turned off and the long column of water is stopped by a check valve. The force of the sudden stop may cause surges which operate the pressure switch contacts, thus subjecting the starter to "chattering."

"Backspin" is the name given to the backward turning of a centrifugal pump when a head of water runs back through the pump just after it has been turned off. Obviously starting the pump during backspin might damage the pump or motor.

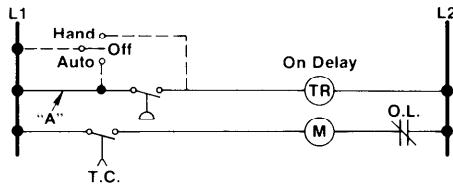
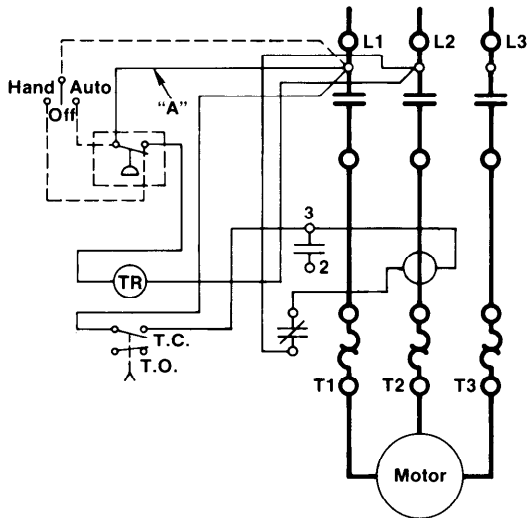

System Provides Backspin Protection and Surge Protection on Stopping. — Time Delay Between Pressure Switch Closing and Motor Starting

The pressure switch energizes the timer (TR), but the motor cannot start until the time delay contact has closed. The timer can thus be set for a time long enough to allow all surges and backspin to stop.

The dotted lines show how a selector switch can be added to by-pass the pressure switch if necessary. This is often used for motor testing purposes. It does not eliminate the time delay however. If the selector switch is added, the wire "A" must be removed.

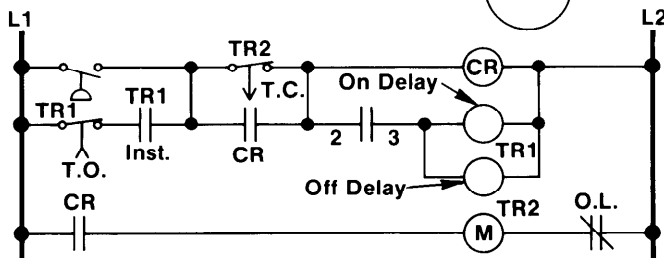
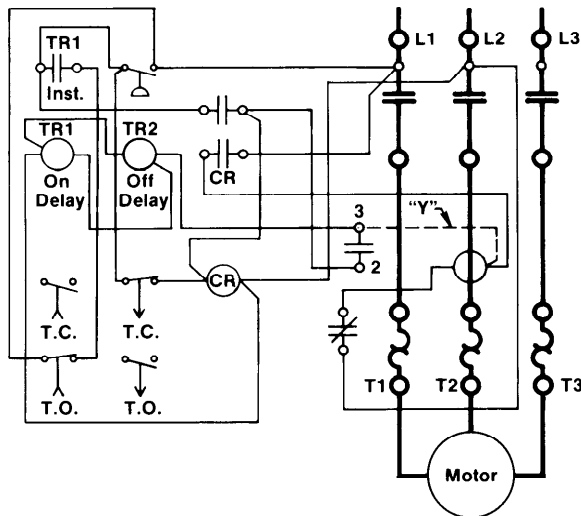

System Provides Surge Protection on Both Starting and Stopping. Backspin Protection Automatically Included

Two timing relays are used here, one to provide surge protection on starting and one to provide surge protection on stopping and backspin protection. TR1 is an "on-delay" timer used for surge protection on starting. When the pressure switch contact closes, relay CR, the starter and the two timers are energized. The instantaneous contact on TR1 closes, by-passing the pressure switch contact and preventing the pump motor starter from dropping out even though starting surges open the pressure contact. After the timing period, the time delay contact TR1 opens the by-pass and PS can then stop the pump at the proper pressure. TR2 is an "off-delay" timer for surge protection on stopping and backspin protection. Once turned off, the system cannot be operated again until timer TR2 has timed out and its normally closed contact is closed.

When a standard Bulletin 509 starter without push buttons is used, connection "Y" must be removed.

Sequence Control

Sequence Control of Two Motors— One to Start and Run for a Short Time After the Other Stops

In this system it is desired to have a second motor started automatically when the first is stopped. The second motor is to run only for a given length of time. Such an application might be found where the second motor is needed to run a cooling fan or a pump.

To accomplish this an off-delay timer (TR) is used. When the start button is pressed, it energizes both M1 and TR. The operation of TR closes its time delay contact but the circuit to M2 is kept open by the opening of the instantaneous contact. As soon as the stop button is pressed, both M1 and TR are dropped out. This closes the instantaneous contact on TR and starts M2. M2 will continue to run until TR times out and the time delay contact opens.

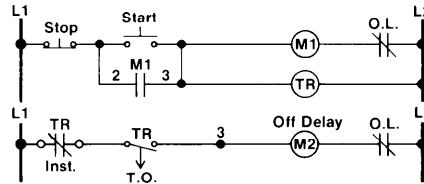
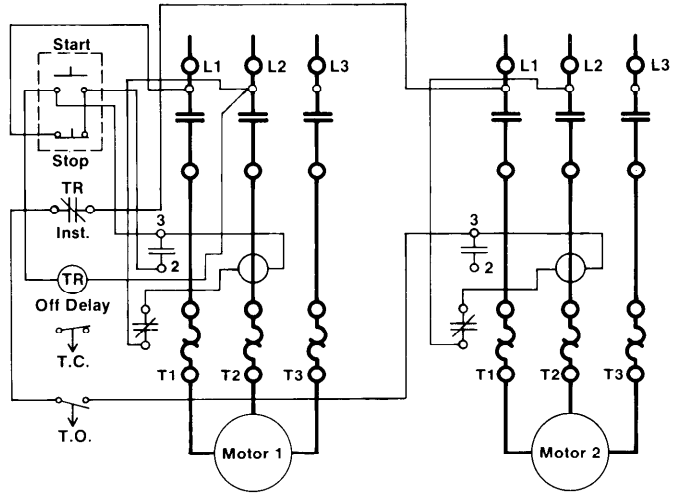

35

Starters Arranged for Sequence Control of a Conveyor System

The two starters are wired so that M2 cannot be started until M1 is running. This is necessary if M1 is driving a conveyor fed by another conveyor driven by M2. Material from the M2 conveyor would pile up if the M1 conveyor could not move and carry it away.

If a series of conveyors is involved, the control circuits of the additional starters can be interlocked in the same way. That is, M3 would be connected to M2 in the same "step" arrangement that M2 is now connected to M1, and so on.

The M1 stop button or an overload on M1 will stop both conveyors. The M2 stop button or an overload on M2 will stop only M2.

If standard Bul. 509 starters are used, wire "X" must be removed from M2.

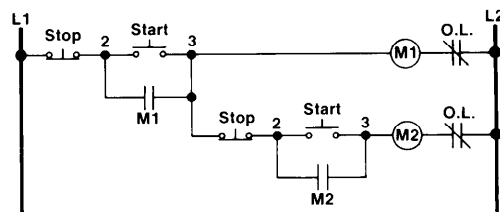
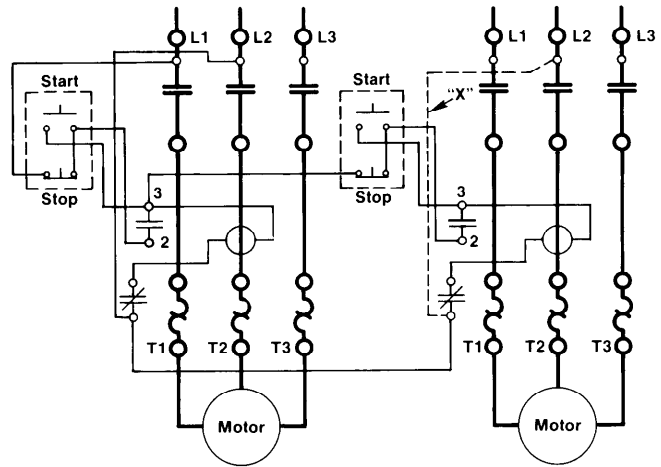

NOTE: Control circuit is connected only to the lines of Motor 1.

36

Sequence Control

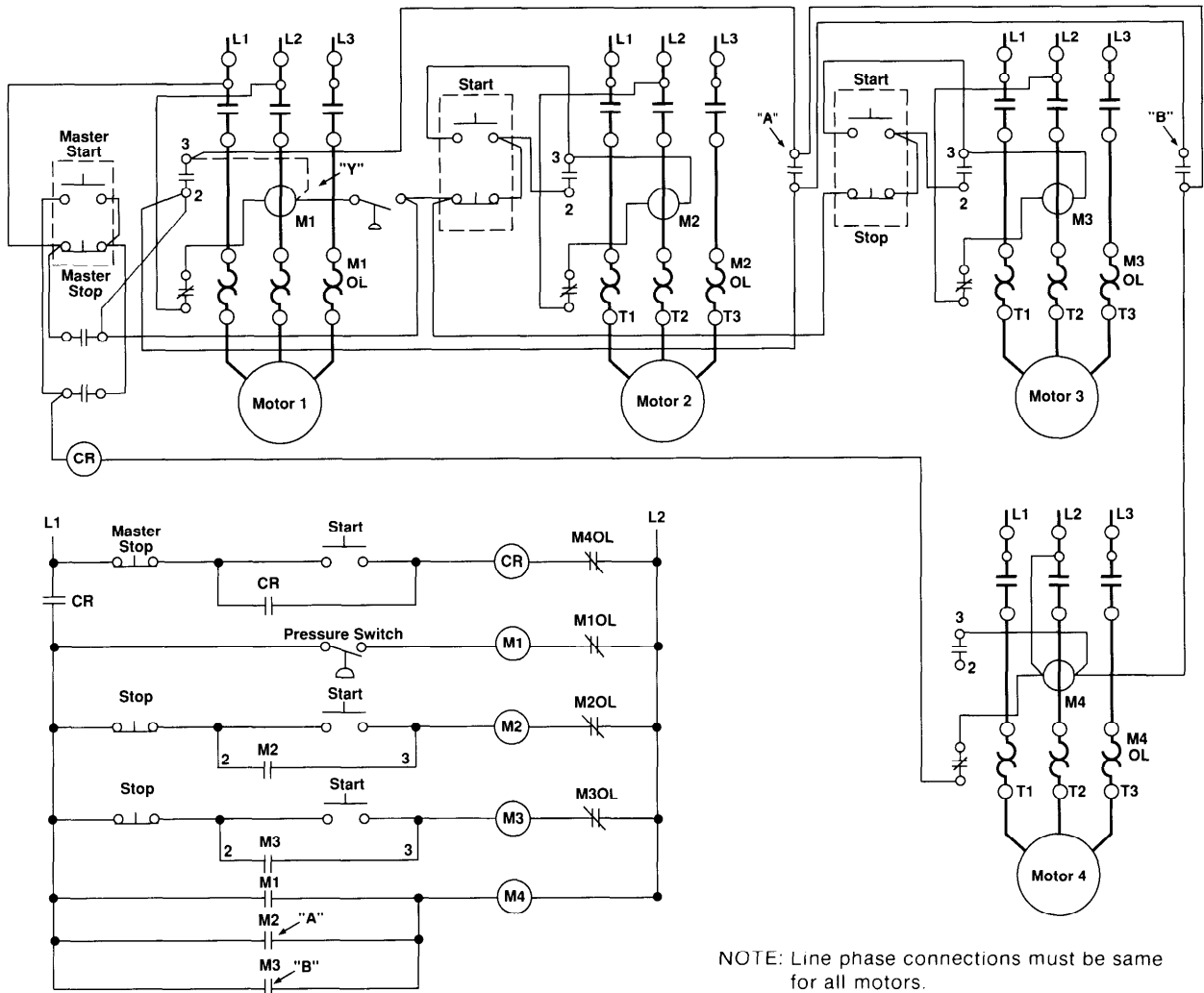

NOTE: Line phase connections must be same for all motors.

Operation of Any One of Several Starters Causes a Pump or Fan Motor to Start

Several motors are to be run independent of each other, with some of the starters actuated by two-wire and some by three-wire pilot devices. Whenever any one of these motors is running, a pump or fan motor must also run.

A master start and stop push button station with a control relay is used to shut down the entire system in an emergency. Control relay (CR) provides "three-wire control" for M1 which is controlled by a two wire control device such as a pressure switch. Motors M2 and M3 are controlled by START-STOP push button stations.

Auxiliary contacts on M1, M2, and M3 control M4. These auxiliary contacts are all wired in parallel so that any one of them may start M4. Bulletin 595 auxiliary contacts have been added to M2 and M3 for this purpose. The standard "hold-in" contact on M1 may be used as an auxiliary if wire "Y" is removed. "Hold-in" contacts are not required when a two-wire control device is used.

The Bulletin 595 auxiliary contacts are designed as "A" and "B" on the wiring diagram. These contacts are easily added to any Allen-Bradley Bulletin 500 starter sizes 0 through 4.

When this system is used, the phase connections on all of the starters must be the same. That is, L1 of each starter must be connected to the same incoming phase line, L2 and L3 of each starter must be similarly phased out.



The Bulletin 505 Full Voltage Reversing Starter

THE BULLETIN 505 AS REPRESENTED BY A WIRING DIAGRAM

A photograph and a wiring diagram of an Allen-Bradley Bulletin 505 reversing starter are shown on this page. The two can be compared as was done with the Bulletin 509. This should help make the meaning of the wiring diagram clearer and should be quite useful when making connections to an actual starter.

Because of the more involved wiring of the Bulletin 505, all of the connections cannot be clearly seen in the photograph. However, comparison with the wiring diagram should assist in tracing any wire on the photograph. Only the wires most likely to be worked with on the standard starter have been labeled.

Each reversing starter is equipped with a mechanical interlock. However, the mechanical interlock, armature, crossbar and overload reset mechanism are not shown in the wiring diagram since these parts need not be considered from a wiring standpoint.

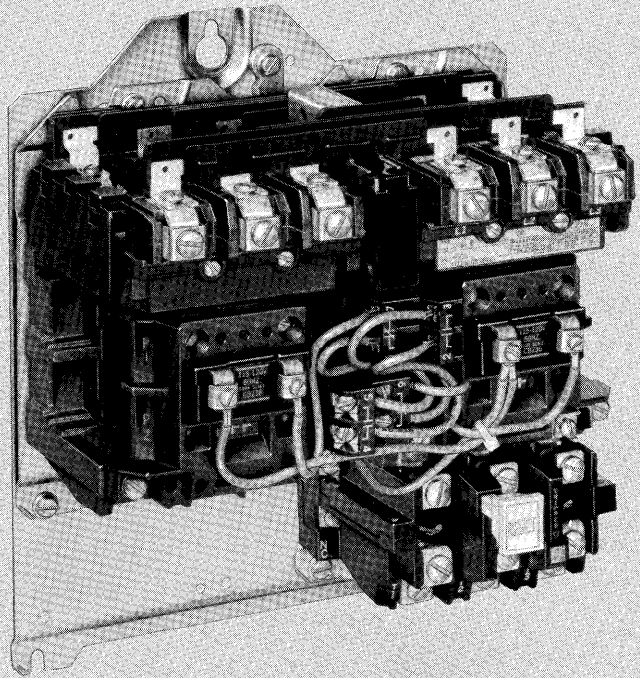

Bulletin 505 starters are most commonly used for full voltage starting and reversing of polyphase squirrel cage motors. These reversing starters may also be used on motor plugging applications when derated. Starters are electrically and mechanically interlocked to avoid both contactors being closed simultaneously.

Starters are equipped as standard with Bulletin 592 block type manual reset overload relays.

Wiring Diagram of Bulletin 505, Size 1

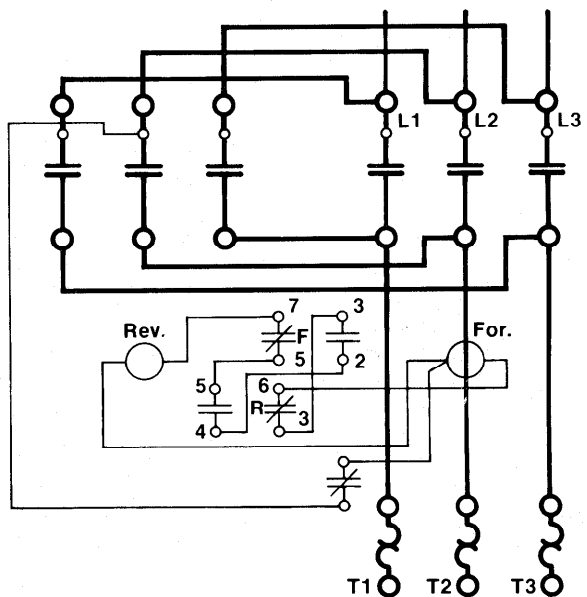

3-Phase Starters

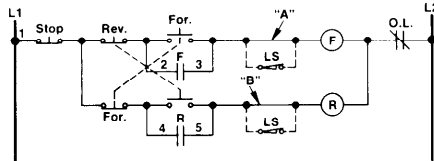
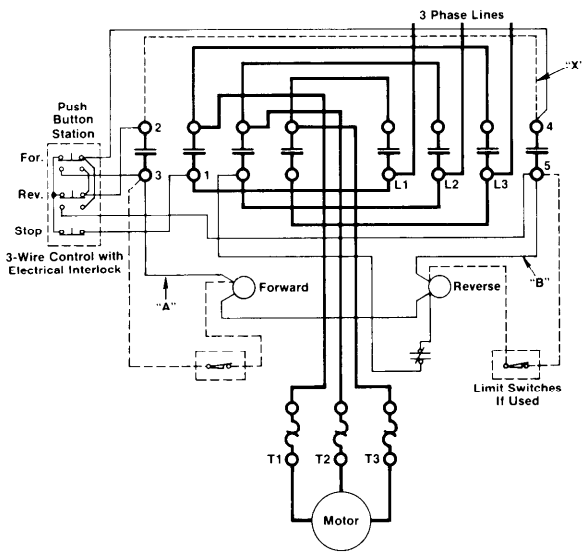

Bulletin 505 Size 00

Standard wiring with "FORWARD-REVERSE-STOP" push button station.

A mechanical interlock is provided, however electrical interlocks are not furnished on size 00 reversing starters. Electrical interlocking can be provided within the push button station, as shown in the diagram. When using this arrangement, wire "X" must be removed.

Limit switches can be added to stop the motor at a certain point in either direction. Connections "A" and "B" must be removed when limit switches are used.

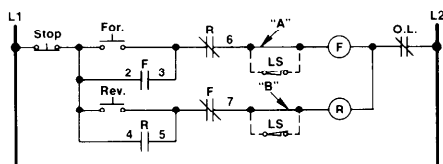
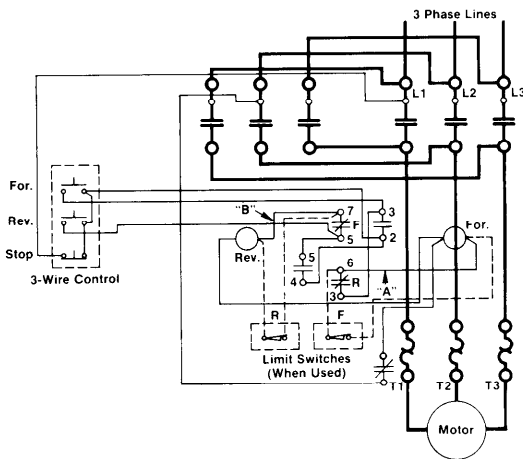

Bulletin 505 Sizes 0, 1, 2, 3 and 4

Standard wiring with "FORWARD-REVERSE-STOP" push button station. The "STOP" button must be depressed before changing directions.

A mechanical interlock and electrical interlocks are supplied as standard on all reversing starters size 0 and larger.

Limit switches can be added to stop the motor at a certain point in either direction. Connections "A" and "B" must be removed when limit switches are used.

Push Button Station Variations

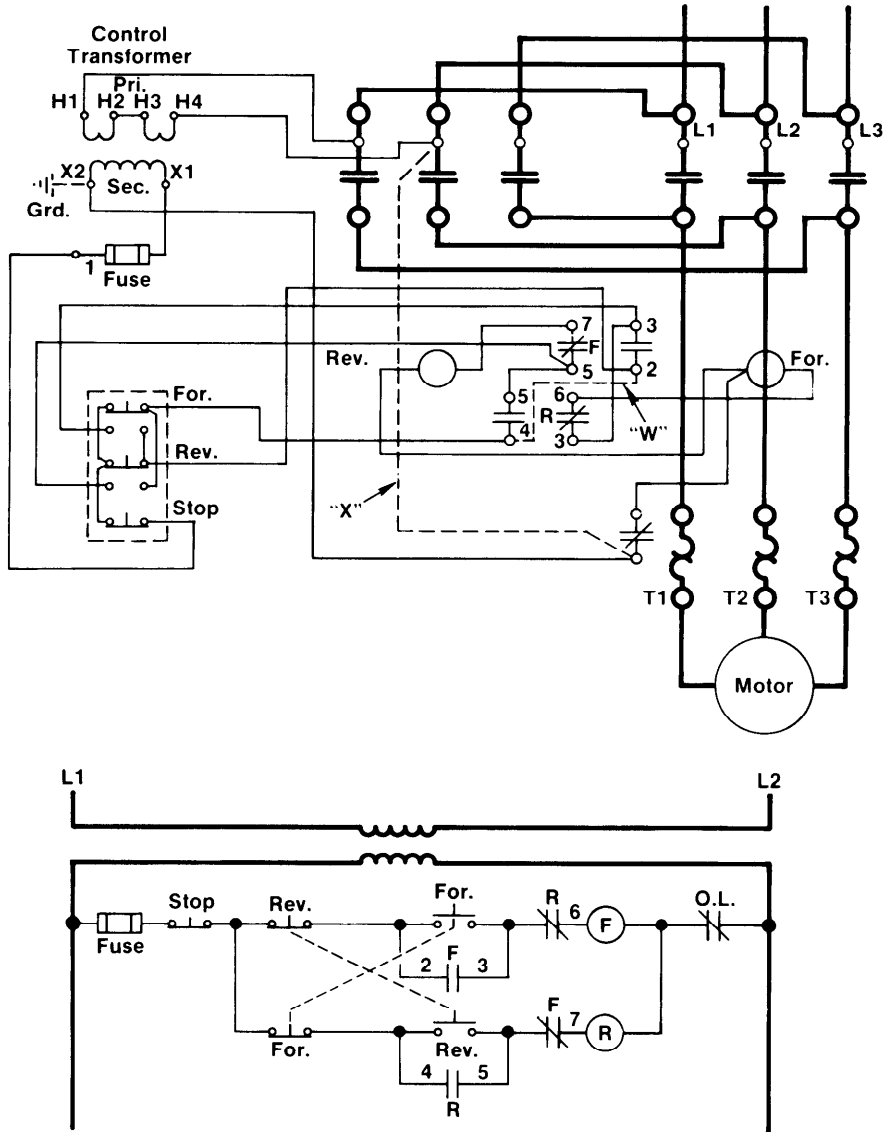

Push Button Wired so Starter Can Be Switched from One Direction to the Other Without Pushing STOP Button

This scheme allows immediate reversal of the motor when it is running in either direction. It is not necessary to depress the "STOP" button when changing direction. A standard Bulletin 505 reversing switch can be used if wire "W" is removed.

The diagram shows the control circuit set up for reduced voltage control, although this may not be necessary in many cases. Notice that wire "X" must be removed when reduced voltage control is used. The push button station can be a Catalog Number 800S-3SA (standard duty), 800H-3HA (heavy duty) or a Catalog Number 800T-3TA (oiltight).

Push Button Station Variations

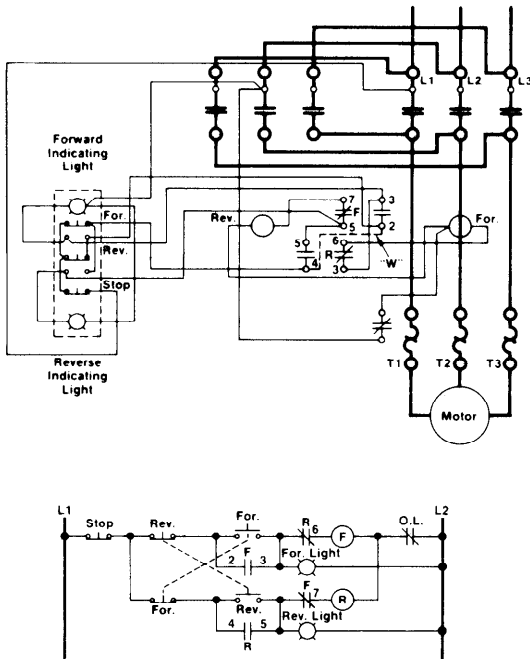

Starting and Stopping in Both Directions. Lights Indicate Direction in Which Motor is Operating

This setup provides exactly the same operation as shown in the previous diagram, except that pilot lights have been added to show which way the motor is running. Once again, standard Bulletin 505 reversing switch can be used if wire "W" is removed. The pilot lights can either be separately mounted or mounted in the push button station. A Catalog Number 800H-3HA2P can be used.

41

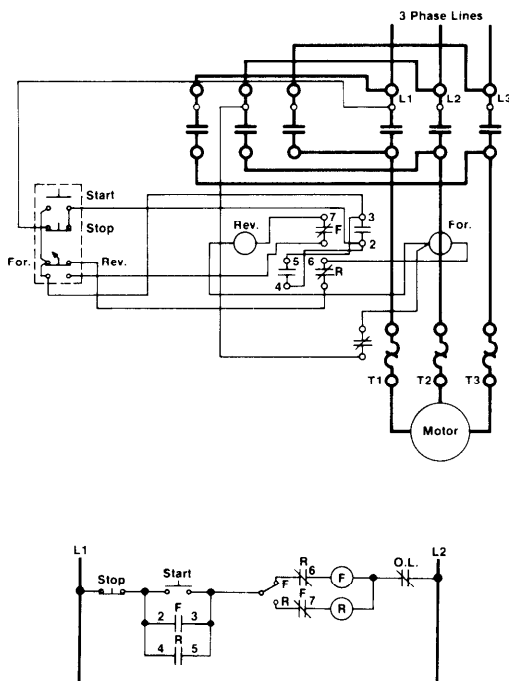

The Motor Runs in a Preselected Direction Which is Determined by The Setting of a Selector Switch

The motor can be run in either direction, but the desired direction must be set on a selector switch before starting. The motor is then operated from a "START-STOP" station as a single direction motor.

The wiring of the standard Bulletin 505 reversing starter must be modified slightly to fill this requirement. Note that the connections which normally lead from the electrical interlock contacts to points 3 and 5 have been removed and that different connections have been made to the electrical interlocks and points 3 and 5.

It is usually most convenient to include the selector switch as part of the push button station. This can be done with either a Bulletin 800H heavy duty station or a Bulletin 800T oiltight station.

42

Push Button Station Variations

Limit Switch Controls Reversing

Here the direction of the motor is determined by the position of a limit switch. A START-STOP push button station is used to energize the system and the motor will start according to the position of the limit switch. The wiring of the standard Bulletin 505 need not be modified for this type of operation. Limit switch connections are made directly to the electrical interlocks.

It is necessary to use a control relay in this system such as a Catalog Number 700-C200. The limit switch can be any of several in the Bulletin 802T line having one NO and one NC contact.

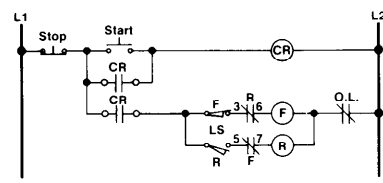
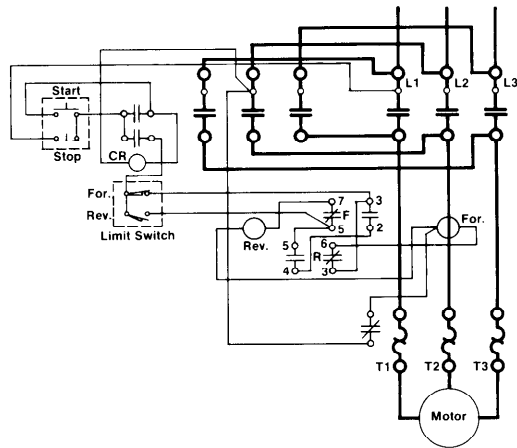

Jogging

Jogging With Relays

In this arrangement for jogging and running in either direction "jogging relays" are used to provide proper jogging. These relays guard against either the forward or reverse contactor locking in during jogging.

The push button station can be a Bulletin 800H, heavy duty, or a Bulletin 800T oiltight. Catalog Number 700-C200 relays may be used.

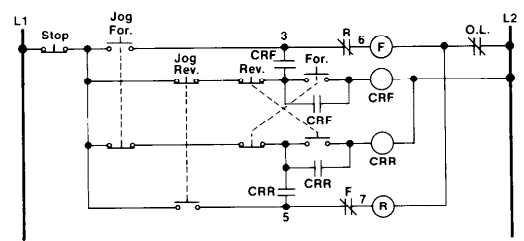
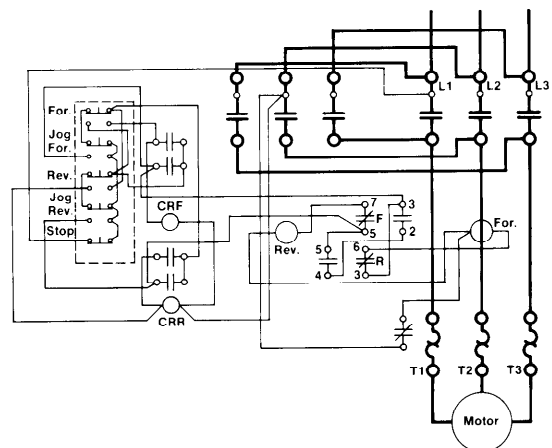

Jogging

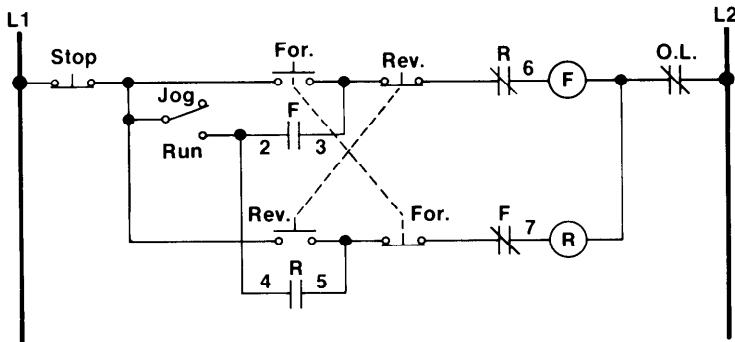
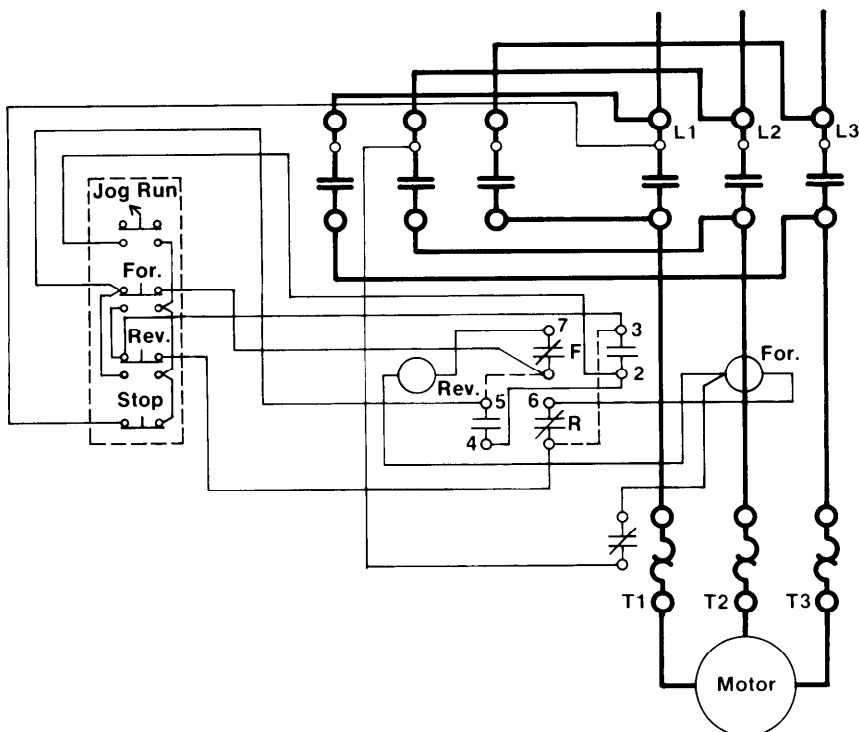

Starting, Stopping and Jogging in Either Direction. Jogging Controlled Through a Jogging Selector Switch

Here, the motor can run normally in either direction or can be jogged in either direction. With the selector in the "RUN" position, the motor can be started in either direction and will stop when the STOP button is pressed. It is not necessary to press the STOP button before changing from forward to reverse.

With the selector in the "JOG" position, the "FORWARD" and "REVERSE" buttons act as jogging buttons. The motor will run in the indicated direction when one of them is pressed but will stop as soon as the button is released.

The wiring of the standard Bulletin 505 must be modified for this type of operation. Note that the wires shown with dotted lines must be removed from the standard starter. The push button station can be either a Bulletin 800H heavy duty, or a Bulletin 800T, oiltight.

Plugging

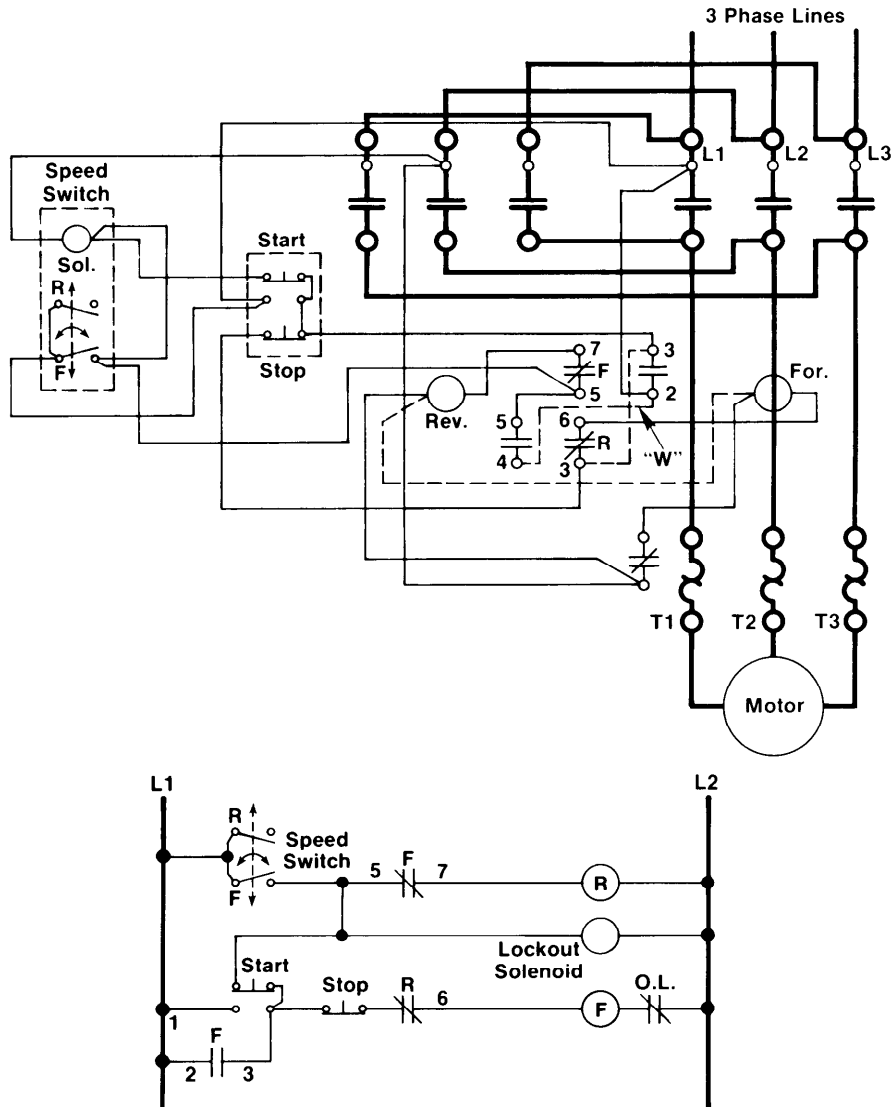

Plugging a Motor to a Stop from One Direction— Lockout Solenoid Provided

This system is for a motor that is to run in one direction only and must come to an immediate stop when the stop button is pressed. The reverse contactor of the Bulletin 505 reversing switch is used only for plug-stopping and not for running in reverse. When a standard Bulletin 505 is used, wire "W" and all wires represented by dotted lines should be removed.

The lockout solenoid is built into the Bulletin 808 Speed Switch and its function is to guard against an accidental turn of the motor shaft closing the speed switch contacts and starting the motor. This protective feature is optional and the speed switch can be furnished without lockout solenoid if desired.

The push button station is a Catalog Number 800H-2HA or a Catalog Number 800T-2TA.

Plugging

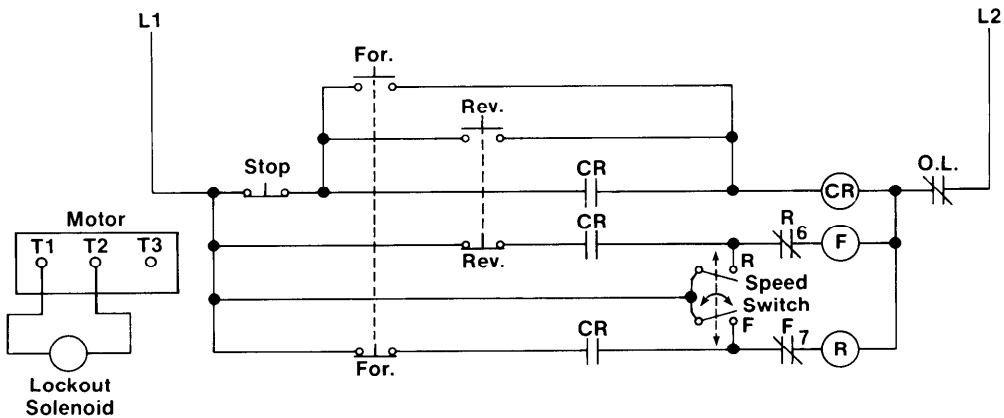
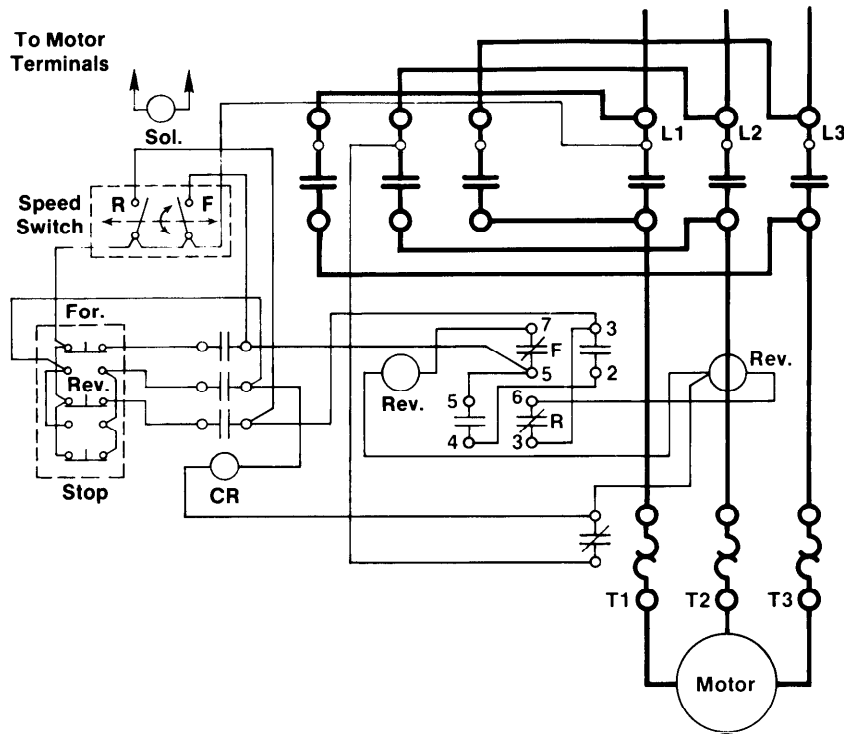

NOTE: CR must be located within the starter enclosure.

Plugging a Motor to a Stop from Either Direction — Lockout Solenoid Provided

With the system wired as shown, the motor can be started in either direction by pressing the proper button. Pressing the STOP button will plug the motor to a stop from either direction. A standard Bulletin 505 reversing switch is used for this application.

The lockout solenoid is a built-in part of the Bulletin 808 Speed Switch and it guards against an accidental turn of the motor shaft closing the speed switch contacts and starting the motor. This protective feature is optional and the speed switch can be furnished without lockout solenoid if desired.

The control relay necessary with this system is a Catalog Number 700-B300 and the push button station can be a Catalog Number 800H-3HA or a Catalog Number 800T-3TA.

“ANTI-PLUGGING”

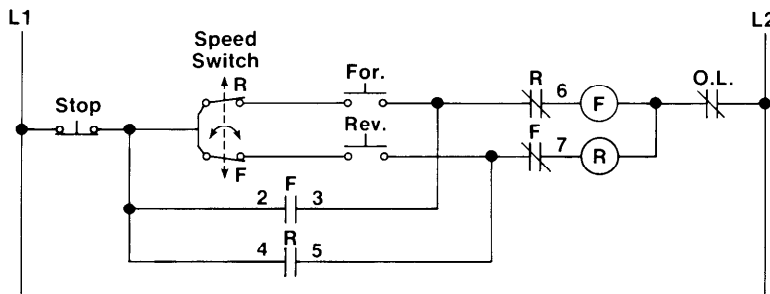
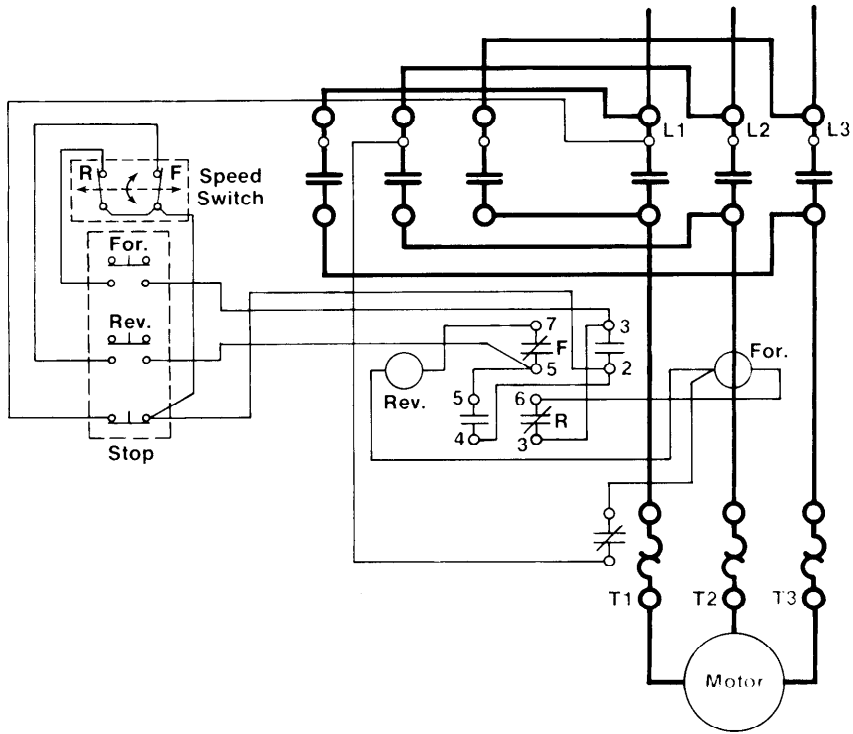

“ANTI-PLUGGING” — Motor Is to Be Reversed, but It Must Not Be Plugged

A Bulletin 808 Speed Switch with normally closed contacts is used for anti-plugging. The schematic diagram shows that with the motor operating in one direction, a contact on the Speed Switch opens the control circuit of the starter used for the opposite direction. The open contact will not close until the motor has slowed down, and thus, the reversing switch cannot be energized to change the direction of the motor until the motor is moving slowly.

A standard Bulletin 505 reversing switch can be used with this application. The push button station can be a Catalog Number 800S-3SA, or a Catalog Number 800H-3HA, or a Catalog Number 800T-3TA.

BULLETIN 520 MULTI-SPEED MOTOR STARTERS

Shown below are Bulletin 520 multi-speed starters of the types used in the diagrams on the following pages. Wiring of these starters can be compared to the diagrams in the same manner as was done for the Bulletin 509 on page 11 and the Bulletin 505 on page 26. Size 1 starters are used in the illustrations and diagrams, but the operating principle and wiring is similar for other sizes.

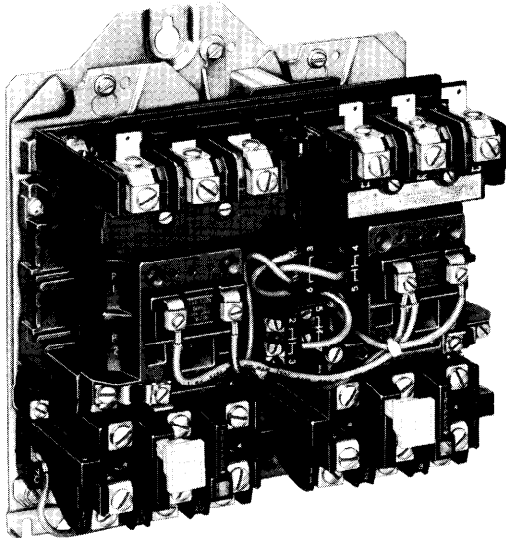

**For
Separate Winding
Motors**

**For
Consequent Pole Motors,
Constant Torque or
Variable Torque
— OR —
For
Consequent Pole Motors,
Constant Horsepower**

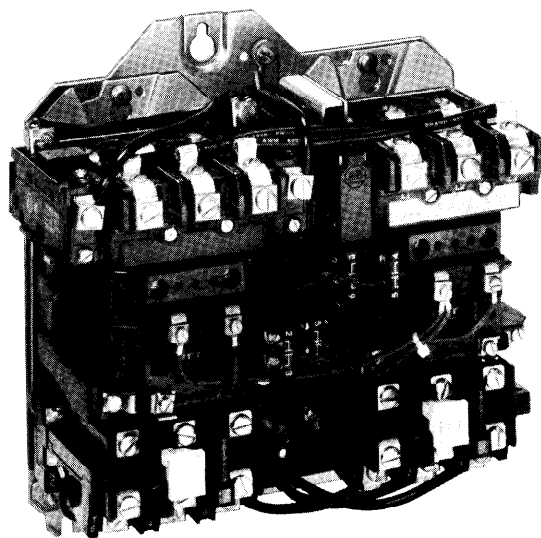

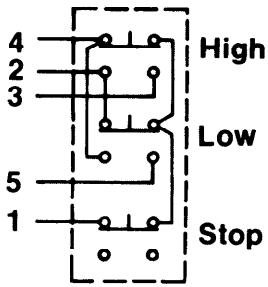

Push button connections to allow starting in either speed and changing from one speed to another without first pressing the "STOP" button.

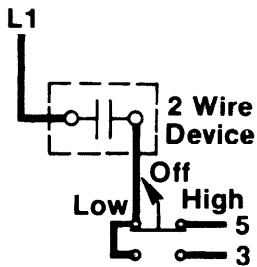

Control by an automatic "two-wire" device. A selector switch is used to determine speed.

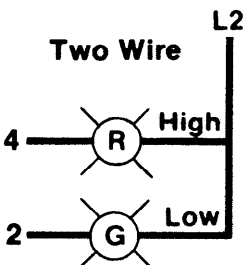
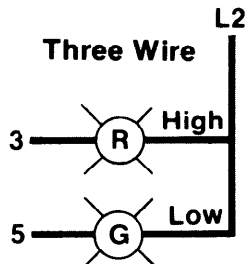

Connections for speed-indicating pilot lights. Can be added to any of the control schemes shown on this page.

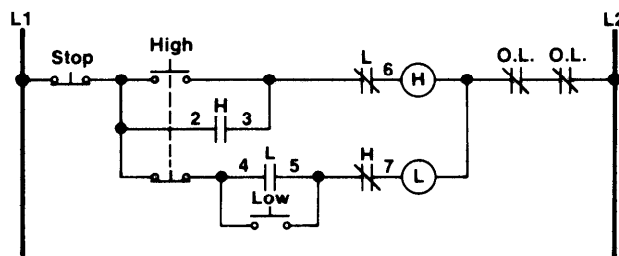
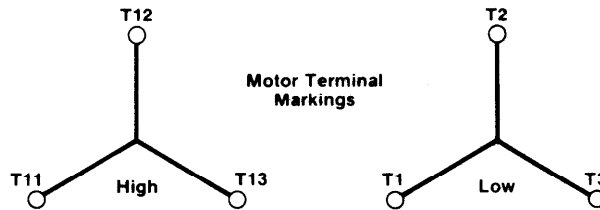
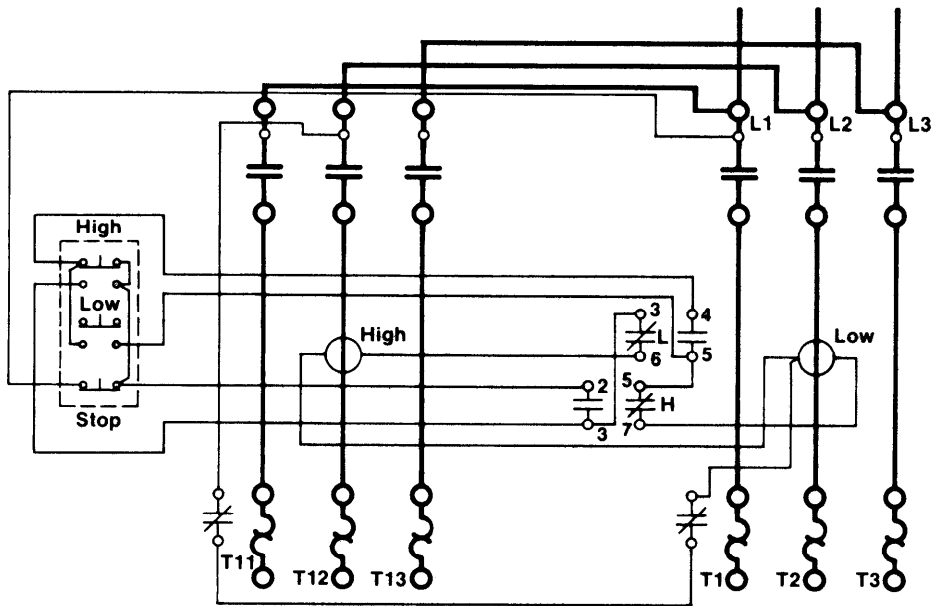

For Separate Winding Motors

A typical connection for a Bulletin 520 used with a two speed separate winding motor is shown above. The wiring diagram and line diagram in the above panel illustrate connections for the following method of operation: Motor can be started in either "HIGH" or "LOW" speed. The change from LOW to HIGH can be made without first pressing STOP button. When changing from HIGH to LOW the STOP button must be pressed between speeds.

The pilot device diagrams shown in the side panel illustrate other connections that can be made to obtain different sequences and methods of operation.

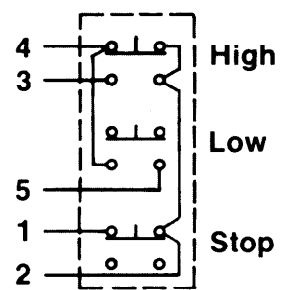
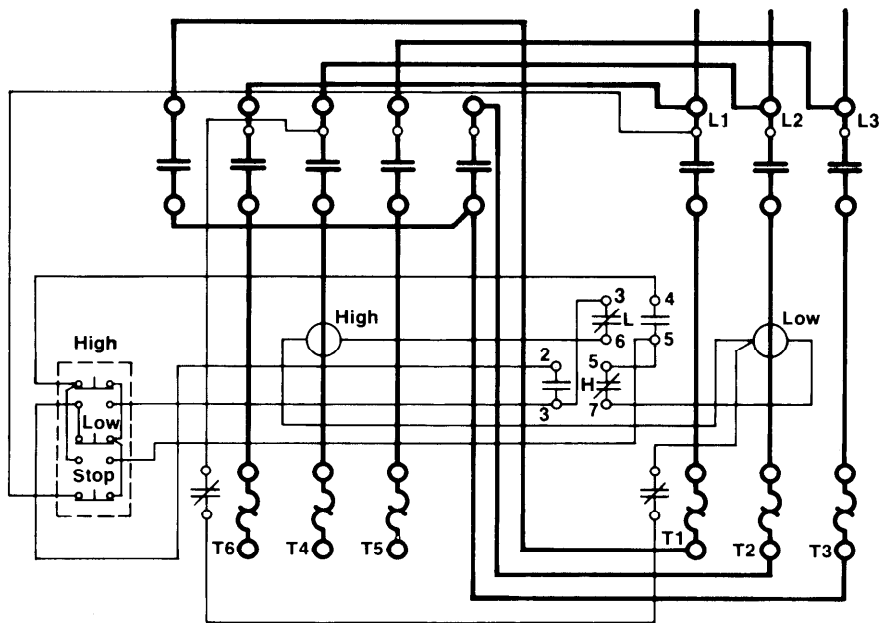

Connections above allow speed change from "LOW" to "HIGH" only without using "STOP." Start in either speed.

CONNECTIONS MADE BY STARTER				
Speed	Supply Lines	Open	Together	
Low	L1 L2 L3	T4, 5, 6	None	
High	T6 T4 T5	None	T1, 2 3	

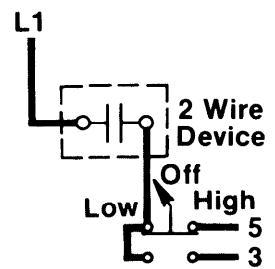
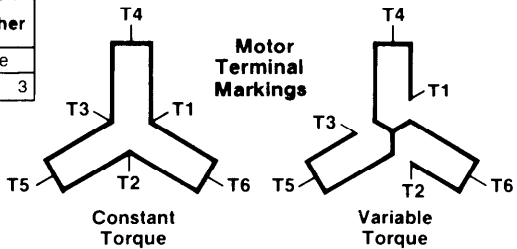

Control by an automatic "two-wire" device. A selector switch is used to determine speed.

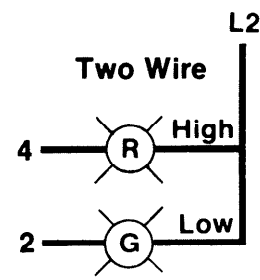
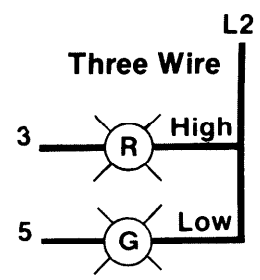
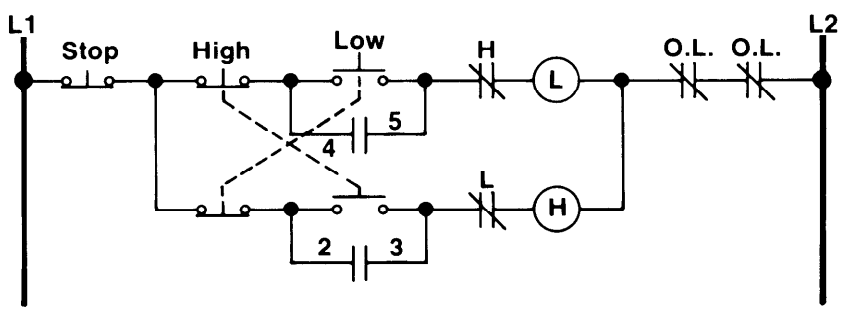

For Consequent Pole Motors — Constant Torque or Variable Torque

For typical connection for a Bulletin 520 used with a consequent pole, constant or variable torque motor is shown above. The wiring diagram and the line diagram in the above panel illustrate connections for the following method of operation: Motor can be started in either "HIGH" or "LOW" speed. The change from LOW to HIGH or from HIGH to LOW can be made without first pressing STOP button.

The pilot device diagrams shown in the side panel illustrate other connections that can be made to obtain different sequences and methods of operation.

Connections for speed-indicating pilot lights. Can be added to any of the control schemes shown on this page.

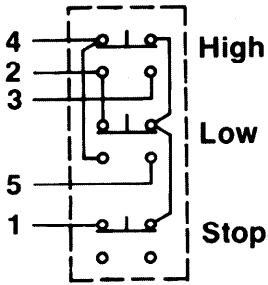

Push button connections to allow starting in either speed and changing from one speed to another without first pressing the "STOP" button.

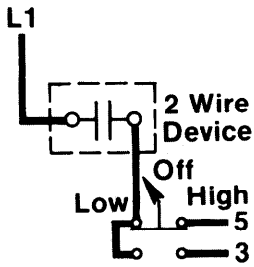

Control by an automatic "two-wire" device. A selector switch is used to determine speed.

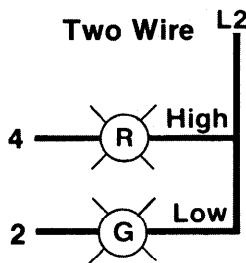
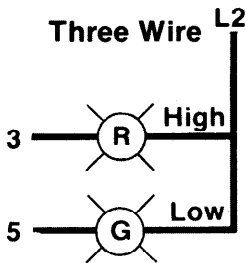

Connections for speed-indicating pilot lights. Can be added to any of the control schemes shown on this page.

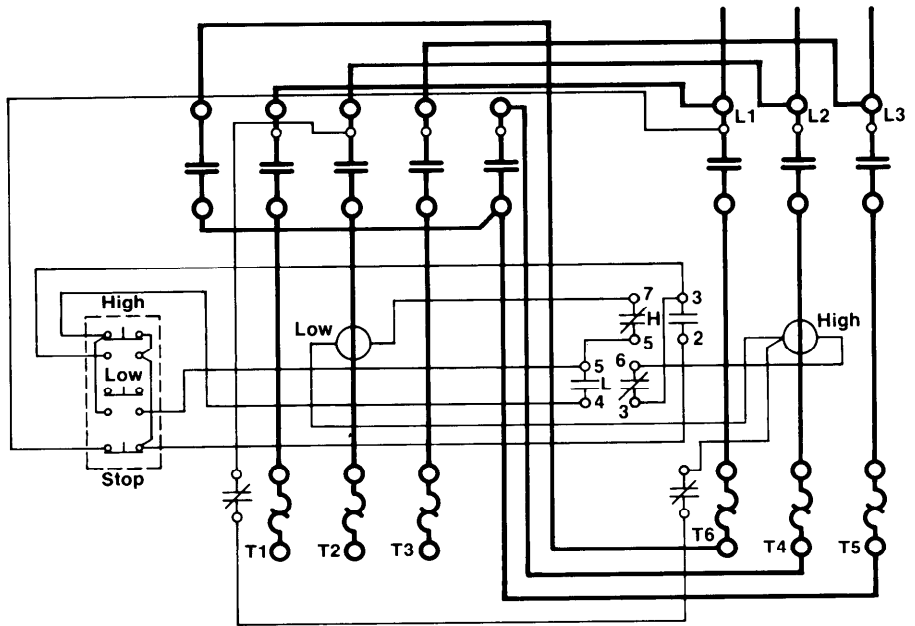

CONNECTIONS MADE BY STARTER					
Speed	Supply Lines			Open	Together
	L1	L2	L3		
Low	T1	T2	T3	None	T4, 5, 6
High	T6	T4	T5	T1, 2, 3	None

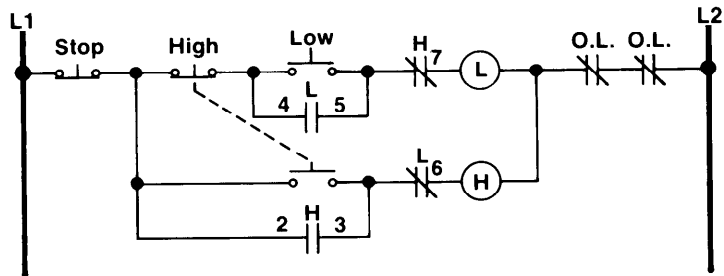
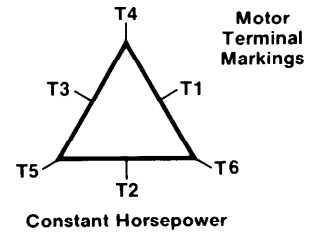

For Consequent Pole Motors — Constant Horsepower

A typical connection for a Bulletin 520 used with a consequent pole constant horsepower motor is shown above. The wiring diagram and line diagram in the above panel illustrate connections for the following method of operation: Motor can be started in either "HIGH" or "LOW" speed. The change from LOW to HIGH can be made without first pressing STOP button. When changing from HIGH to LOW the STOP button must be pressed between speeds.

The pilot device diagrams shown in the side panel illustrate other connections that can be made to obtain different sequences and methods of operation.



ALLEN-BRADLEY
A ROCKWELL INTERNATIONAL COMPANY

Allen-Bradley has been helping its customers improve productivity and quality for 90 years. It designs, manufactures and supports a broad range of control and automation products worldwide. They include logic processors, power and motion control devices, man-machine interfaces and sensors. Allen-Bradley is a subsidiary of Rockwell International, one of the world's leading technology companies.



With major offices worldwide.

Algeria • Argentina • Australia • Austria • Bahrain • Belgium • Brazil • Bulgaria • Canada • Chile • China, PRC • Colombia • Costa Rica • Croatia • Cyprus • Czech Republic • Denmark • Ecuador • Egypt • El Salvador • Finland • France • Germany • Greece • Guatemala • Honduras • Hong Kong • Hungary • Iceland • India • Indonesia • Israel • Italy • Jamaica • Japan • Jordan • Korea • Kuwait • Lebanon • Malaysia • Mexico • New Zealand • Norway • Oman • Pakistan • Peru • Philippines • Poland • Portugal • Puerto Rico • Qatar • Romania • Russia-CIS • Saudi Arabia • Singapore • Slovakia • Slovenia • South Africa, Republic • Spain • Switzerland • Taiwan • Thailand • The Netherlands • Turkey • United Arab Emirates • United Kingdom • United States • Uruguay • Venezuela • Yugoslavia

World Headquarters, Allen-Bradley, 1201 South Second Street, Milwaukee, WI 53204 USA, Tel: (1) 414 382-2000 Fax: (1) 414 382-4444