HELICOFLEX®



Garlock Helicoflex

High Performance Seals and Sealing Systems

GENERAL INFORMATION

The Helicoflex® seal represents the leading edge in seal technology for high performance sealing applications. Today's extreme sealing requirements have rendered traditional seals & gaskets obsolete. If you can't afford the lost time associated with leaks, put your trust in the leader: Helicoflex®.

SEALING CONCEPT

The sealing principle of the Helicoflex® family of seals is based upon the plastic deformation of a jacket of greater ductility than the flange materials. This occurs between the sealing face of a flange and an elastic core composed of a close-wound helical spring. The spring is selected to have a specific compression resistance. During compression, the resulting specific pressure forces the jacket to yield and fill the flange imperfections while ensuring positive contact with the flange sealing faces. Each coil of the helical spring acts independently and allows the seal to conform to surface irregularities on the flange surface. This combination of elasticity and plasticity makes the Helicoflex seal the best overall performing seal in the industry.

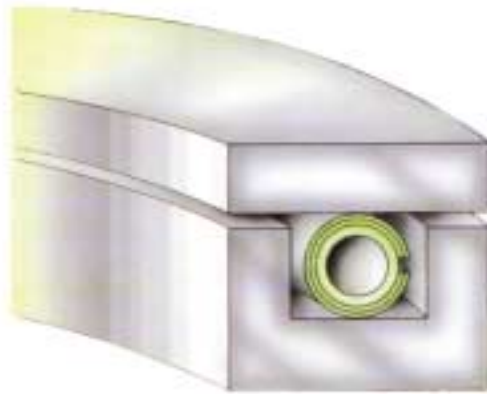

Free State

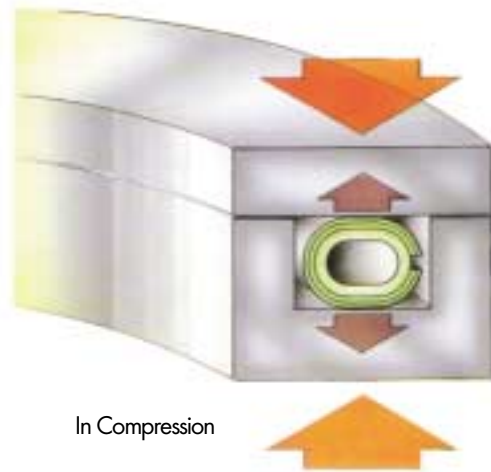

In Compression

GENERAL CHARACTERISTICS

- Wide range of applications:
 - Dimensional: Diameters from 0.250 inches (6.3 mm) to over 300 inches (7.6 m)
 - Cross sections from 0.063 inches (1.6 mm) to over 0.625 inches (15.9 mm)
 - Temperature: Cryogenic to 1800 °F (982 °C)
 - Pressure: Ultra High Vacuum to 50,000 PSI (100,000 PSI under special conditions)
- Excellent springback: the spring energized Helicoflex is capable of compensating for flange distortions due to temperature and pressure cycling.
- Adaptable to a majority of standard flanges: ANSI, ISO, KF, ASA
- Suited to different types of assemblies:
 - metal/metal with groove
 - flat flanges with limiter/retainer
 - 3 face contact
- Extended shelf life
- Excellent resistance to corrosion and radiation
- Minimum relaxation: the Helicoflex's resilient spring compensates for relaxation ensuring positive seal contact.

CLASSIFICATION OF SEAL TYPE

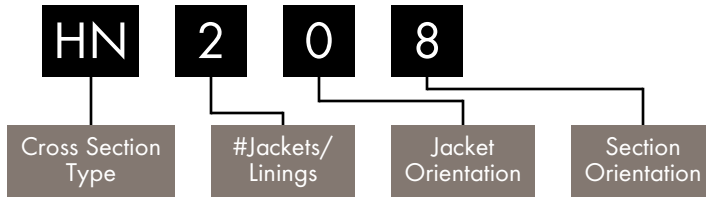

CONFIGURATION GUIDE

Cross Section Type	HN	single section								
	HNR	ground spring for precise load control (Beta Spring)								
	HNV	low load (Delta Seal)								
	HND	tandem Helicoflex seals								
	HNDE	tandem Helicoflex and elastomer seals note: "L" indicates internal limiter (ex: HLDE)								
Jacket/Lining	1 = jacket only									
	2 = jacket with inner lining									
Jacket Orientation	0	1	2	3	4	5	6	7	8	9
Section Orientation	0	1	2	3	4	5	6	7	8	9

TYPICAL CONFIGURATIONS

<p>HN200</p> <p>Groove assemblies</p>	<p>HN240</p> <p>3 face compression</p>
<p>HN208</p> <p>Raised face flanges - ANSI B16.5</p>	<p>HN203</p> <p>Tongue & groove</p>
<p>HNDE290</p> <p>Leak check - inert gas purge</p>	<p>HND229</p> <p>Valve seats</p>

CHARACTERISTIC CURVE

The resilient characteristic of the Helicoflex® seal ensures useful elastic recovery during service. This elastic recovery permits the Helicoflex® seal to accommodate minor distortions in the flange assembly due to temperature and pressure cycling. For most sealing applications the Y_0 value will occur early in the compression curve and the Y_1 value will occur near the end of the decompression curve.

The compression and decompression cycle of the Helicoflex® seal is characterized by the gradual flattening of the compression curve. The decompression curve, which is distinct from the compression curve, is the result of a hysteresis effect and permanent deformation of the spring and jacket.

DEFINITION OF TERMS

- Y_0 = load on the compression curve above which leak rate is at required level
- Y_2 = load required to reach optimum compression e_2
- Y_1 = load on the decompression curve below which leak rate exceeds required level
- e_2 = optimum compression
- e_c = compression limit beyond which there is risk of damaging the spring

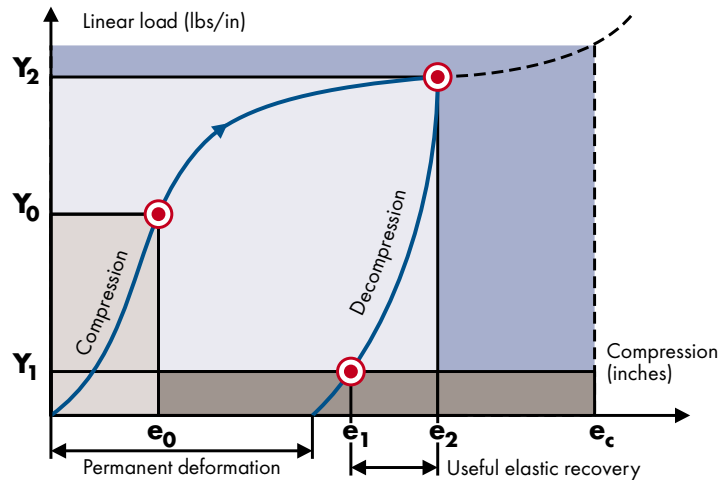

INTRINSIC POWER OF THE SEAL

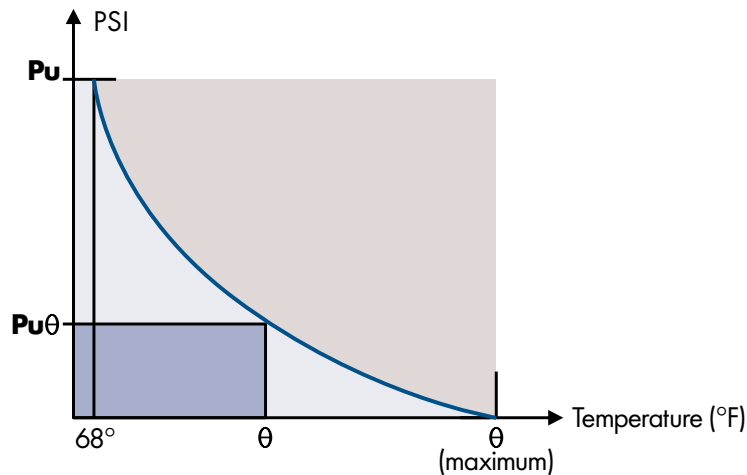

The intrinsic power of the Helicoflex seal reflects its ability to maintain and hold system pressure for a given temperature at Y_2 and e_2 . This value is expressed as a specific pressure and is noted by the symbols P_u (room temperature) and $P_{u\theta}$ (at operating temperature). The influence of temperature on P_u is shown in the graph above. The tables on pages 10 and 11 give the values of P_u at 68°F (20°C), $P_{u\theta}$ at a given temperature and the maximum temperature where $P_{u\theta} = 0$.

DEFINITION OF CHARACTERISTIC VALUES

D_j	Mean reaction diameter of the seal. (For a double section seal, $D_j = D_{j1} + D_{j2}$)	_____ inches
Y₂	Linear load corresponding to e ₂ compression	_____ lbs/inch
Y₁	Linear load on the seal to maintain sealing in service at low pressure (=Y _{m1})	_____ lbs/inch
P_u	Intrinsic power of the seal under pressure at 68 °F (20 °C) when the reaction force of the seal is maintained at Y ₂ , regardless of the operating conditions.	_____ PSI
P_{uθ}	Value of P _u at temperature θ	_____ PSI
P	Operating or proof pressure Note: if $\frac{P}{P_u \text{ or } P_{u\theta}} > 1$, the definition of the seal must be modified <i>This ratio must never exceed 1.</i>	_____ PSI
Y_{m2}	Linear tightening load on the seal at room temperature to maintain sealing under pressure. $Y_{m2} = Y_2 \frac{P}{P_u}$	_____ lbs/inch
Y_{m2θ}	Value of Y _{m2} at temperature θ. $Y_{m2\theta} = Y_2 \frac{P}{P_{u\theta}}$	_____ lbs/inch
E_t	Young's modulus of bolt material at 68 °F (20 °C)	_____ PSI
E_{t_s}	Young's modulus of bolt material at operating temperature	_____ PSI

LOAD CALCULATIONS

F_j	Total tightening load to compress the seal to the operating point (Y ₂ ; e ₂) $F_j = \pi \times D_j \times Y_2$	_____ lbs
F_F	Total hydrostatic end force $F_F = \pi/4 D_{j1}^2 \times P$ (D _{j1} = D _j in case of a single section seal)	_____ lbs
F_m	Minimum total load to be maintained on the seal in service to preserve sealing, i.e. $F_m = \pi D_j Y_m$ where: Y _m = the greater of the two values: Y _{m1} or Y _{m2θ} (see note 1 below)	_____ lbs
F_s	Total load to be applied on the bolts to maintain sealing in service. $F_s = F_F + F_m$	_____ lbs
F_s*	Increased value of F _s to compensate for Young's modulus at temperature $F_s^* = F_s E_t / E_{t_s}$	_____ lbs
F_B	LOAD TO BE APPLIED: If $F_s^* > F_j$ then $F_b = F_s^*$ If $F_j > F_s^*$ then $F_b = F_j$	_____ lbs

Note 1: wherever the working pressure is high and/or seal diameter is big, to such an extent that $P \cdot D_j \geq 32 Y_m$, in order to remain on the safe side, whatever the inaccuracy on the tightening load may be, it is recommended to take the F_j value in lieu of F_m for the calculation of F_s so that $F_s = F_F + F_j$.

Note 2: this information is provided as a reference only.

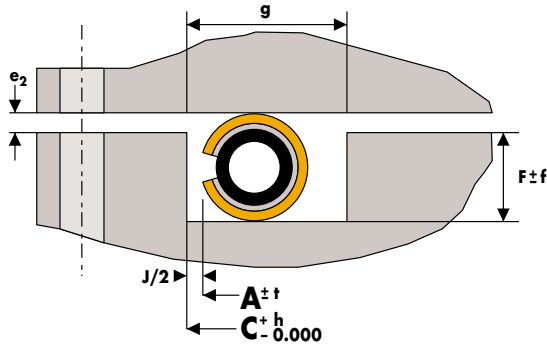

CALCULATIONS

Groove Depth (F)	= Cross Section (CS)-e ₂
Depth Tolerance (f)	= e ₂ X 0.12
Groove Width (g)	= See table below
Seal OD (A)	= Groove OD (C) - Clearance (J)
Groove Finish	= See table below
Flatness	= See table below

CLEARANCE AND MINIMUM GROOVE WIDTH

Seal Cross Section	Pressure < 300 psi (20 bar)		Pressure ≥ 300 psi (20 bar)	
	Clearance J	Min Groove Width g	Clearance J	Min Groove Width g
CS				
0.059 to 0.134	1.5	3.4	J = 0.012	J = 0.3
0.138 to 0.272	3.5	6.9	J = 0.020	J = 0.5
0.276 to 0.390	7.0	9.9	J = 0.028	J = 0.7

SEAL / GROOVE TOLERANCES

Seal Diameter Range	Pressure < 300 psi (20 bar)		Pressure ≥ 300 psi (20 bar)	
	Seal Tolerance t	Groove Tolerance h	Seal Tolerance t	Groove Tolerance h
0.350 to 2.000	3.8	50.0	0.005	0.13
2.001 to 12.000	50.0	305.0	0.010	0.25
12.001 to 25.000	305.0	635.0	0.010	0.25
25.001 to 48.000	635.0	1220.0	0.015	0.38
48.001 to 72.000	1220.0	1830.0	0.020	0.51
> 72.000	> 1830.0		Consult our engineering staff	

SURFACE FINISH

Nr. LCA-CEA	N10	N9	N8	N7	N6	N5	N4
Ra in μm	12.5	6.3	3.2	1.6	0.8	0.4	0.2
Rt in μm	50	37	21	11	6.2	3.4	1.9
RMS	500	250	125	63	32	16	8
Aluminum	○	○	⊙	⊙	⊙	○	○
Silver, copper, iron		○	⊙	⊙	○	○	
Nickel, stainless steel		○	○	⊙	⊙	○	○

⊙ recommended ○ consult our engineering staff

Note: Machining/polishing marks must follow seal circumference

SHAPED SEALS

Groove Design: Contact our engineering staff for assistance in designing non-circular grooves.

Groove Finish: Most applications will require a finish of 16-32 RMS (0.4 to 0.8 Ra μm). All machining & polishing marks must follow seal circumference.

Min. Seal Radius: The minimum seal bending radius is six times the seal cross section (CS).

Seating Load: The load (Y2) to seat the seal is approximately 30% higher due to a slightly stiffer spring design.

FLATNESS

Seal Diameter Range	Amplitude	Tangential Slope	Radial Slope		
0.350 to 20.000	10 to 500	0.008	0.2	1:1000	1:100
20.001 to 80.000	500 to 2000	0.016	0.4	2:1000	2:100

Dimensions in inches | Dimensions in mm

THREE FACE COMPRESSION

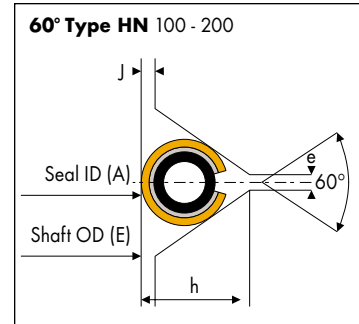
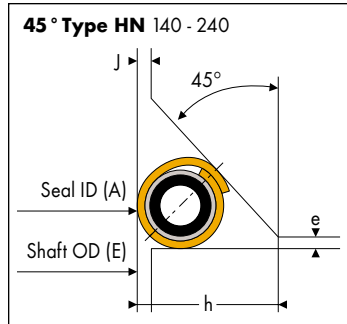
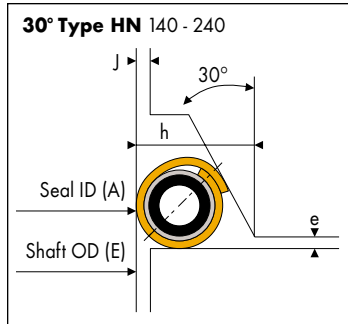

$$E = \text{Shaft OD} \begin{matrix} +0.000 \\ -0.002 \end{matrix}$$

$$\begin{matrix} +0.00 \\ -0.05 \end{matrix}$$

$$A = \text{Seal D} \begin{matrix} +0.002 \\ -0.000 \end{matrix}$$

$$\begin{matrix} +0.05 \\ -0.00 \end{matrix}$$

CALCULATIONS

Axial Load (Ya)	= K · Y2
Shaft OD (E)	= Seal ID (A)
Clearance (J)	< CS / 10
Axial Compression (e)	= a · e ₂
Cavity Finish	< 32 RMS (0.8 um)

COEFFICIENT VALUES

Coefficient	30°	45°	60°
a	2	1.4	1.15
K	0.9	1.2	1.4

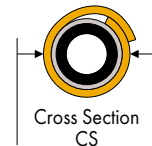

"h" VALUES

Cross Section CS	30°				45°				60°			
	Aluminum Jacket		Other Jackets		Aluminum Jacket		Other Jackets		Aluminum Jacket		Other Jackets	
in mm	in	mm	in	mm	in	mm	in	mm	in	mm	in	mm
0.102 2.6	0.130	3.30	0.126	3.20	0.163	4.15	0.157	4.00	0.126	3.20	0.134	3.40
0.126 3.2	0.157	4.00	0.157	4.00	0.199	5.05	0.199	5.05	0.157	4.00	0.165	4.20
0.165 4.2	0.207	5.25	0.207	5.25	0.260	6.60	0.260	6.60	0.213	5.40	0.220	5.60
0.205 5.2	0.260	6.60	0.260	6.60	0.327	8.30	0.327	8.30	0.272	6.90	0.280	7.10
0.252 6.4	0.321	8.15	0.321	8.15	0.402	10.20	0.402	10.20	0.339	8.60	0.346	8.80

Dimensions in inches | Dimensions in mm

TARGET SEALING CRITERIA

The ultimate leak rate of a joint is a function of the seal design, flange design, bolting, surface finish and other factors. Helicoflex seals are designed to provide two levels of service: Helium Sealing or Bubble Sealing.

Helium Sealing: These Helicoflex seals are designed with a target Helium leak rate not to exceed 1×10^9 cc/sec.atm under a ΔP of 1 atmosphere. The ultimate leak rate will depend on the factors listed above.

Bubble Sealing: These Helicoflex seals are designed with a target air leak rate not to exceed 1×10^4 cc/sec.atm under a ΔP of 1 atmosphere.

CALCULATIONS ACCORDING TO CODES

	D.I.N. 2505 1990	A.S.M.E. Section VIII Division 1	CODAP 1995	Garlock Helicoflex CEFILAC
Operating load	$F_{DV} = \pi \cdot d_D \cdot k_O \cdot K_{DV}$	$W_{m2} = \pi \cdot b \cdot G \cdot y$	$F_A = \pi \cdot D_j \cdot J_E \cdot P_A$	$F_j = \pi \cdot D_j \cdot Y_2$
Hydrostatic force	$F_P = \pi \cdot \frac{(d_D)^2}{4} \cdot P$	$H = \pi \cdot \frac{G^2}{4} \cdot P$	$F_F = \pi \cdot \frac{(D_j)^2}{4} \cdot P$	$F_F = \pi \cdot \frac{(D_j)^2}{4} \cdot P$
Minimum service load	$F_{DB} = \pi \cdot d_D \cdot k_B \cdot P$	$H_p = 2 \cdot b \cdot \pi \cdot G \cdot m \cdot P$	$F_j = 2 \cdot \pi \cdot D_j \cdot J_E \cdot m \cdot P$	$F_m = \pi \cdot D_j \cdot Y_m$ $Y_m = Y_{m1} = Y_1 \cdot \frac{P}{P_{U\theta}}$ $Y_{m2} = Y_2 \cdot \frac{P}{P_{U\theta}}$ Use the greater of the two
Minimum tightening load to apply on bolts	$F_{SO} = \begin{matrix} (1) F_{DV} \\ (2) F_P + F_{DB} \end{matrix}$ Use the greater of the two (1) or (2)	$W = \begin{matrix} (1) W_{m2} \\ (2) H + H_p = W_{m1} \end{matrix}$ Use the greater of the two (1) or (2)	$F_S = \begin{matrix} (1) F_A \\ (2) F_F + F_j \end{matrix}$ Use the greater of the two (1) or (2)	$F_B = \begin{matrix} (1) F_j \\ (2) F_F + F_j = F_S \end{matrix}$ Use the greater of the two (1) or (2)

EQUIVALENT SYMBOLS

	D.I.N. 2505 1990	A.S.M.E. Section VIII Division 1	CODAP 1995	Garlock Helicoflex CEFILAC
Operating load	$F_{DV} = F_j$ $d_D = D_j$ $k_O \cdot K_{DV} = Y_2$ \downarrow $F_{DV} = \pi \cdot D_j \cdot Y_2$	$W_{m2} = F_j$ $b = 1$ $G = D_j$ $Y = Y_2$ \downarrow $W_{m2} = \pi \cdot D_j \cdot Y_2$	$F_A = F_j$ $D_j = D_j$ $J_E = 1$ $P_A = Y_2$ \downarrow $F_A = \pi \cdot D_j \cdot Y_2$	
Hydrostatic force	$F_P = F_F$ $d_D = D_j$ \downarrow $F_P = \pi \cdot \frac{(D_j)^2}{4} \cdot P$	$H = F_F$ $G = D_j$ \downarrow $H = \pi \cdot \frac{(D_j)^2}{4} \cdot P$	$F_A = F_F$ $D_j = D_j$ \downarrow $F_F = \pi \cdot \frac{(D_j)^2}{4} \cdot P$	
Minimum service load	$F_{DB} = F_m$ $d_D = D_j$ $k_B \cdot P = Y_m$ \downarrow $F_{DB} = \pi \cdot D_j \cdot Y_m$	$H_p = F_m$ $b = 1$ $G = D_j$ $2 \cdot m \cdot P = Y_m$ $m = \frac{Y_m}{2 \cdot P}$ \downarrow $H_p = \pi \cdot D_j \cdot Y_m$	$F_j = F_m$ $D_j = D_j$ $J_E = 1$ $2 \cdot m \cdot P = Y_m$ $m = \frac{Y_m}{2 \cdot P}$ \downarrow $F_j = \pi \cdot D_j \cdot Y_m$	
Minimum bolt load	$F_{SO} = F_B$ $F_{SO} = \begin{matrix} (1) F_j \\ (2) F_F + F_m = F_S \end{matrix}$ Use the greater of the two (1) or (2)	$W = F_B$ $W = \begin{matrix} (1) F_j \\ (2) F_F + F_m = F_S \end{matrix}$ Use the greater of the two (1) or (2)	$F_S = F_B$ $F_S = \begin{matrix} (1) F_j \\ (2) F_F + F_m = F_S \end{matrix}$ Use the greater of the two (1) or (2)	

Note: Due to its circular cross section, the Helicoflex seal exhibits a "line" load instead of an "area load" typical of traditional gaskets. As a result, "m", "b" and "y" factors are not pertinent when applied to the Helicoflex seal. The above equivalent equations were developed to assist flange designers with their calculations.

ANSI B16.5 RAISED FACE FLANGE

The Helicoflex® HN208a is ideally suited for standard raised face flanges. The resilient nature of the seal allows it to compensate for the extremes of high temperature and pressure where traditional spiral wounds and double jacketed seals fail. The jacket and spring combination can be modified to meet most requirements of temperature and pressure. In addition, a large selection of jacket materials ensures chemical compatibility in corrosive and caustic media.

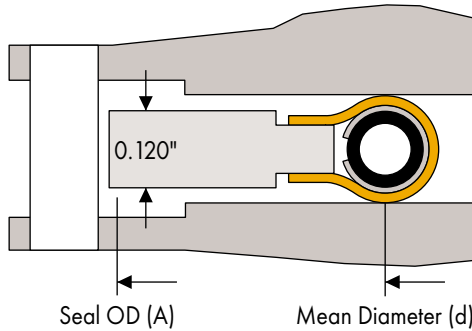

SEAL TYPE: HN208a

Jacket	Availability	Cross Section (inches)	Seating Load (lbs/in)*	Recommended Flange Finish (RMS)
Aluminum	Standard	0.160	1150	63 - 125
Silver	Standard	0.160	1725	63 - 125
Copper	Standard	0.155	2250	63 - 125
Soft Iron	Optional	0.155	2250	32 - 63
Nickel	Standard	0.150	2800	32 - 63
Monel	Optional	0.150	2800	32 - 63
Hastelloy C	Optional	0.150	2800	32 - 63
Stainless Steel	Standard	0.150	3800	32 - 63
Alloy 600	Optional	0.150	3800	32 - 63
Alloy X750	Optional	0.150	4000	32 - 63
Titanium	Optional	0.150	4000	32 - 63

* Note: Seating load only! Does not allow for hydrostatic end force. See page 5 for calculations.

SEAL DIMENSIONS

Nominal Diameter	Mean Diameter (d)	Seal OD (A)						
		150lb	300lb	400lb	600lb	900lb	1500lb	2500lb
1/2	0.827	1.874	2.126	2.126	2.126	2.500	2.500	2.752
3/4	1.102	2.252	2.626	2.626	2.626	2.752	2.752	3.000
1	1.417	2.626	2.874	2.874	2.874	3.122	3.122	3.374
1-1/4	1.890	3.000	3.252	3.252	3.252	3.500	3.500	4.126
1-1/2	2.283	3.374	3.752	3.752	3.752	3.874	3.874	4.626
2	2.913	4.126	4.374	4.374	4.374	5.626	5.626	5.752
2-1/2	3.425	4.874	5.126	5.126	5.126	6.500	6.500	6.626
3	4.173	5.374	5.874	5.874	5.874	6.626	6.874	7.752
3-1/2	4.685	6.374	6.500	6.500	6.374	N/A	N/A	N/A
4	5.256	6.874	7.126	7.000	7.626	8.126	8.252	9.252
5	6.378	7.752	8.500	8.374	9.500	9.752	10.000	11.000
6	7.500	8.752	9.874	9.752	10.500	11.413	11.126	12.500
8	9.567	10.996	12.126	12.000	12.626	14.126	13.874	15.252
10	11.693	13.374	14.252	14.126	15.752	17.126	17.126	18.760
12	13.858	16.126	16.626	16.500	18.000	19.626	20.500	21.626
14	15.098	17.752	19.126	19.000	19.374	20.500	22.752	N/A
16	17.205	20.252	21.252	21.126	22.252	22.626	25.252	N/A
18	19.567	21.626	23.500	23.374	24.126	25.126	27.752	N/A
20	21.575	23.874	25.752	25.500	26.874	27.500	29.752	N/A
24	25.728	28.252	30.500	30.252	31.126	32.996	35.500	N/A

Note: Consult our engineering staff for other available sizes and materials.

Jacket Material	HELIUM SEALING							BUBBLE SEALING				
	Cross Section In	e ₂ in	e _C in	Y ₂ lbs/inch	Y ₁ lbs/inch	Pu68 °F PSI	Puθ392 °F PSI	Y ₂ lbs/inch	Y ₁ lbs/inch	Pu68 °F PSI	Puθ392 °F PSI	Max Temp °F
Aluminum	0.063	0.024	0.028	857	114	7250	N/A	514	114	5075	N/A	302
	0.075	0.028	0.033	914	114	7540	N/A	571	114	5800	N/A	302
	0.087	0.028	0.035	942	114	7685	N/A	600	114	5800	N/A	356
	0.098	0.028	0.035	999	114	7975	725	657	114	6090	725	428
	0.118	0.031	0.039	1056	143	7975	1450	742	114	6525	1450	482
	0.138	0.031	0.039	1085	143	7975	2030	799	114	6815	2030	482
	0.157	0.035	0.043	1142	143	8700	2465	857	114	7250	2465	536
	0.177	0.035	0.047	1199	143	8700	2900	914	114	7540	2900	536
	0.197	0.035	0.055	1256	171	9135	3190	971	143	7975	3190	572
	0.217	0.035	0.063	1313	171	9425	3480	1028	143	8265	3480	608
	0.236	0.039	0.071	1399	200	9715	3625	1113	171	8700	3625	644
	0.276	0.039	0.087	1542	228	10150	4060	1171	200	9425	4060	644
	0.315	0.039	0.102	1656	286	10440	4640	1285	228	9860	4495	680
	Silver							Puθ482 °F				
0.063		0.020	0.024	1142	171	9425	N/A	857	171	5800	N/A	464
0.075		0.024	0.028	1256	171	9425	N/A	857	171	5800	N/A	464
0.087		0.024	0.031	1313	200	10150	N/A	914	171	5800	580	536
0.098		0.028	0.035	1370	257	10875	1160	971	228	6525	725	536
0.118		0.031	0.039	1485	286	12325	2030	1028	257	7250	1305	572
0.138		0.031	0.039	1599	286	13775	3190	1085	257	7975	1885	572
0.157		0.031	0.043	1713	314	15225	3915	1142	286	8700	2320	662
0.177		0.031	0.043	1827	343	16675	4495	1256	286	10150	2755	698
0.197		0.031	0.051	1941	343	18125	5220	1313	286	11600	3190	698
0.217		0.031	0.055	2056	371	19575	5800	1428	343	13050	3625	752
0.236		0.035	0.067	2284	400	21750	6815	1542	343	15950	4350	842
0.276		0.035	0.079	2512	457	23200	7830	1713	371	18125	5220	842
0.315		0.035	0.094	2798	514	24650	8700	1999	400	20300	6090	932
Copper, Soft Iron, Mild Steels							Puθ572 °F					Puθ572 °F
	0.063	0.020	0.024	1485	228	7250	1450	1085	171	5075	725	662
	0.075	0.024	0.028	1599	286	7250	1595	1142	228	5075	870	662
	0.087	0.024	0.031	1713	343	7975	1885	1256	286	5075	1160	680
	0.098	0.028	0.035	1827	400	8700	2465	1313	343	5800	1450	716
	0.118	0.028	0.039	1999	457	9425	2900	1428	400	5800	1740	716
	0.138	0.028	0.039	2227	457	10150	3335	1542	400	6525	2175	752
	0.157	0.031	0.043	2455	514	10150	3915	1656	457	6525	2465	788
	0.177	0.031	0.043	2684	571	11600	4350	1827	457	6525	2755	842
	0.197	0.031	0.051	2912	628	12325	4785	1884	514	7250	3045	842
	0.217	0.031	0.055	3141	685	13050	5220	2056	571	7250	3335	896
	0.236	0.035	0.067	3597	799	13775	5800	2284	571	7975	3770	968
	0.276	0.035	0.079	4225	914	14500	6525	2627	628	8700	4205	968
	0.315	0.035	0.094	4911	1085	15950	7105	3026	742	9425	4640	1022
Nickel, Monel, Tantalum							Puθ662 °F					Puθ662 °F
	0.063	0.016	0.020	1827	457	10150	1595	1142	343	5800	1015	716
	0.075	0.020	0.024	1999	457	10440	2320	1256	343	6090	1305	716
	0.087	0.020	0.028	2227	514	11020	3045	1313	400	6380	1740	788
	0.098	0.024	0.031	2512	571	11890	3915	1542	400	6815	2320	842
	0.118	0.024	0.035	2512	628	12615	4930	1713	457	7250	2900	896
	0.138	0.024	0.035	2798	685	13485	5800	1941	514	7830	3335	932
	0.157	0.028	0.039	3312	799	13920	6525	2170	571	8265	3915	1022
	0.177	0.028	0.039	4111	857	15225	7540	2398	628	8700	4350	1112
	0.197	0.028	0.043	4454	1028	15950	8265	2627	628	9425	4785	1202
	0.217	0.028	0.051	4625	1142	16675	8990	2855	685	9715	5365	1202
	0.236	0.031	0.063	N/A	N/A	N/A	N/A	3198	742	10440	5945	1202
	0.276	0.031	0.071	N/A	N/A	N/A	N/A	3712	857	11310	6525	1202
	0.315	0.031	0.083	N/A	N/A	N/A	N/A	4168	914	12035	7250	1202
Stainless Steel, Inconel, Titanium							Puθ752 °F					Puθ752 °F
	0.063	0.016	0.020	1999	571	13050	3625	1713	457	6815	870	788
	0.075	0.020	0.024	2284	571	13195	3915	1827	457	7250	1160	788
	0.087	0.020	0.028	2570	628	13340	4205	1999	514	7540	1595	896
	0.098	0.024	0.031	2855	685	14065	4640	2170	571	8265	2175	932
	0.118	0.024	0.035	3283	742	14500	5220	2427	628	8990	2900	932
	0.138	0.024	0.035	3769	857	15080	5655	2684	742	9715	3625	1022
	0.157	0.028	0.039	4283	971	15515	6090	2969	857	10440	4350	1112
	0.177	0.028	0.039	4711	1256	15950	6525	3198	1028	11165	4930	1202
	0.197	0.028	0.043	N/A	N/A	N/A	N/A	3426	1085	11890	5365	1292
	0.217	0.028	0.051	N/A	N/A	N/A	N/A	3712	1142	12615	6090	1292
	0.236	0.031	0.063	N/A	N/A	N/A	N/A	4111	1256	13630	6815	1292
	0.276	0.031	0.071	N/A	N/A	N/A	N/A	4568	1485	14790	7540	1292
	0.315	0.031	0.083	N/A	N/A	N/A	N/A	5139	1656	15660	8410	1292

Jacket Material	HELIUM SEALING							BUBBLE SEALING				Max Temp °C
	Cross Section mm	e ₂ mm	e _C mm	Y ₂ daN/cm	Y ₁ daN/cm	Pu20°C daN/cm ²	Puθ200°C daN/cm ²	Y ₂ daN/cm	Y ₁ daN/cm	Pu20°C daN/cm ²	Puθ200°C daN/cm ²	
Aluminum	1.6	0.6	0.7	150	20	50	N/A	90	20	35	N/A	150
	1.9	0.7	0.85	160	20	52	N/A	100	20	40	N/A	150
	2.2	0.7	0.9	165	20	53	N/A	105	20	40	N/A	180
	2.5	0.7	0.9	175	20	55	5	115	20	42	5	220
	3.0	0.8	1.0	185	25	55	10	130	20	45	10	250
	3.5	0.8	1.0	190	25	55	14	140	20	47	14	250
	4.0	0.9	1.1	200	25	60	17	150	20	50	17	280
	4.5	0.9	1.2	210	25	60	20	160	20	52	20	280
	5.0	0.9	1.4	220	30	63	22	170	25	55	22	300
	5.5	0.9	1.6	230	30	65	24	180	25	57	24	320
	6.0	1.0	1.8	245	35	67	25	195	30	60	25	340
7.0	1.0	2.2	270	40	70	28	205	35	65	28	340	
8.0	1.0	2.6	290	50	72	32	225	40	68	31	360	
Silver							Puθ250°C				Puθ250°C	
	1.6	0.5	0.6	200	30	65	N/A	150	30	40	N/A	240
	1.9	0.6	0.7	220	30	65	N/A	150	30	40	N/A	240
	2.2	0.6	0.8	230	35	70	6	160	30	40	4	280
	2.5	0.7	0.9	240	45	75	8	170	40	45	5	280
	3.0	0.8	1.0	260	50	85	14	180	45	50	9	300
	3.5	0.8	1.0	280	50	95	22	190	45	55	13	300
	4.0	0.8	1.1	300	55	105	27	200	50	60	16	350
	4.5	0.8	1.1	320	60	115	31	220	50	70	19	370
	5.0	0.8	1.3	340	60	125	36	230	50	80	22	370
	5.5	0.8	1.4	360	65	135	40	250	60	90	25	400
6.0	0.9	1.7	400	70	150	47	270	60	110	30	450	
7.0	0.9	2.0	440	80	160	54	300	65	125	36	450	
8.0	0.9	2.4	490	90	170	60	350	70	140	42	500	
Copper, Soft Iron, Mild Steels							Puθ300°C				Puθ300°C	
	1.6	0.5	0.6	260	40	50	10	190	30	35	5	350
	1.9	0.6	0.7	280	50	50	11	200	40	35	6	350
	2.2	0.6	0.8	300	60	55	13	220	50	35	8	360
	2.5	0.7	0.9	320	70	60	17	230	60	40	10	380
	3.0	0.7	1.0	350	80	65	20	250	70	40	12	380
	3.5	0.7	1.0	390	80	70	23	270	70	45	15	400
	4.0	0.8	1.1	430	90	70	27	290	80	45	17	420
	4.5	0.8	1.1	470	100	80	30	320	80	45	19	450
	5.0	0.8	1.3	510	110	85	33	330	90	50	21	450
	5.5	0.8	1.4	550	120	90	36	360	100	50	23	480
6.0	0.9	1.7	630	140	95	40	400	100	55	26	520	
7.0	0.9	2.0	740	160	100	45	460	110	60	29	520	
8.0	0.9	2.4	860	190	110	49	530	130	65	32	550	
Nickel, Monel, Tantalum							Puθ350°C				Puθ350°C	
	1.6	0.4	0.5	320	80	70	11	200	60	40	7	380
	1.9	0.5	0.6	350	80	72	16	220	60	42	9	380
	2.2	0.5	0.7	390	80	76	21	230	70	44	12	420
	2.5	0.6	0.8	440	100	82	27	270	70	47	16	450
	3.0	0.6	0.9	440	110	87	34	300	80	50	20	480
	3.5	0.6	0.9	490	120	93	40	340	90	54	23	500
	4.0	0.7	1.0	580	140	96	45	380	100	57	27	550
	4.5	0.7	1.0	720	150	105	52	420	110	60	30	600
	5.0	0.7	1.1	780	180	110	57	460	110	65	33	650
	5.5	0.7	1.3	810	200	115	62	500	120	67	37	650
6.0	0.8	1.6	N/A	N/A	N/A	N/A	560	130	72	41	650	
7.0	0.8	1.8	N/A	N/A	N/A	N/A	650	150	78	45	650	
8.0	0.8	2.1	N/A	N/A	N/A	N/A	730	160	83	50	650	
Stainless Steel, Inconel, Titanium							Puθ400°C				Puθ400°C	
	1.6	0.4	0.5	350	100	90	25	300	80	47	6	420
	1.9	0.5	0.6	400	100	91	27	320	80	50	8	420
	2.2	0.5	0.7	450	110	92	29	350	90	52	11	480
	2.5	0.6	0.8	500	120	97	32	380	100	57	15	500
	3.0	0.6	0.9	575	130	100	36	425	110	62	20	500
	3.5	0.6	0.9	660	150	104	39	470	130	67	25	550
	4.0	0.7	1.0	750	170	107	42	520	150	72	30	600
	4.5	0.7	1.0	825	220	110	45	560	180	77	34	650
	5.0	0.7	1.1	N/A	N/A	N/A	N/A	600	190	82	37	700
	5.5	0.7	1.3	N/A	N/A	N/A	N/A	650	200	87	42	700
6.0	0.8	1.6	N/A	N/A	N/A	N/A	720	220	94	47	700	
7.0	0.8	1.8	N/A	N/A	N/A	N/A	800	260	102	52	700	
8.0	0.8	2.1	N/A	N/A	N/A	N/A	900	290	108	58	700	

RADIAL COMPRESSION

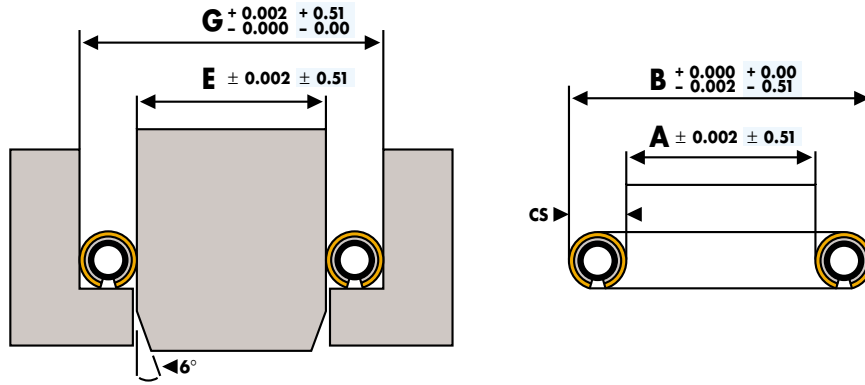

CALCULATIONS

Cavity OD (G)	= Seal OD (B)
Shaft OD (E)	= Seal ID (A) + 2 e ₃
Cavity Finish	< 32 RMS (0.8 um)
Axial Load	= Y _a

Note: For best results, the cavity should be lubricated with a product that is compatible with the medium to be sealed.

CHARACTERISTIC VALUES

CS		Aluminum Jacket				Y _a		CS		Silver Jacket				Y _a		CS		Nickel Jacket				Y _a		
		e ₃								e ₃								e ₃						
in	mm	in	mm	lb/in	daN/cm	in	mm	in	mm	lb/in	daN/cm	in	mm	lb/in	daN/cm	in	mm	in	mm	lb/in	daN/cm	in	mm	
0.063	1.60	0.012	0.30	109	19	0.063	1.60	0.010	0.25	170	30	0.063	1.60	0.008	0.20	228	40							
0.102	2.60	0.014	0.35	137	24	0.102	2.60	0.012	0.30	195	34	0.102	2.60	0.010	0.25	308	54							
0.118	3.00	0.016	0.40	154	27	0.122	3.10	0.014	0.35	206	36	0.126	3.20	0.012	0.30	343	60							
0.157	4.00	0.020	0.50	183	32	0.165	4.20	0.018	0.45	228	40	0.165	4.20	0.016	0.40	434	76							
0.200	5.10	0.020	0.50	206	36	0.205	5.20	0.018	0.45	263	46	0.205	5.20	0.016	0.40	525	92							
0.260	6.60	0.024	0.60	235	41	0.244	6.20	0.020	0.50	308	54	0.252	6.40	0.018	0.45	640	112							

Dimensions in inches | Dimensions in mm

The technical data contained herein is by way of example and should not be relied on for any specific application. Garlock Helicoflex will be pleased to provide specific technical data or specifications with respect to any customer's particular applications. Use of the technical data or specifications contained herein without the express written approval of Garlock Helicoflex is at user's risk and Garlock Helicoflex

expressly disclaims responsibility for such use and the situations which may result therefrom.

Garlock Helicoflex makes no warranty, express or implied, that utilization of the technology or products disclosed herein will not infringe any industrial or intellectual property rights of third parties.

Garlock Helicoflex is constantly involved in engineering and development. Accordingly, Garlock Helicoflex reserves the

right to modify, at any time, the technology and product specifications contained herein.

All technical data, specifications and other information contained herein is deemed to be the proprietary intellectual property of Garlock Helicoflex. No reproduction, copy or use thereof may be made without the express written consent of Garlock Helicoflex.

BFGoodrich

Garlock Helicoflex

PO Box 9889
2770 The Boulevard
Columbia, SC 29290 USA
Phone: 1-803-783-1880
Toll Free: 1-800-233-1722
Fax: 1-803-783-4279
www.helicoflex.com
www.garlock.net

Cefilac, S.A.

90 rue de la Roche-du-Geai
42029 Saint-Etienne, FRANCE
Phone: 011-33-4-77-43-51-00
Fax: 011-33-4-77-43-51-52

Garlock Sealing Technologies

Palmyra, NY, USA 1-315-597-4811
Paragould, AR, USA 1-870-239-4051
Houston, TX USA 1-281-459-7200
Sydney, Australia 61-2-9793-2511
São Paulo, Brazil 55-11-884-9680
Oakville, Canada 1-905-829-3200
Berkshire, England 44-1635-38509
Neuss, Germany 49-2131-3490
Seoul, Korea 822-554-6341
Mexico City, Mexico 52-5-567-7011
Singapore 65-284-7873

Fax: 1-315-597-3216
Fax: 1-870-239-4054
Fax: 1-281-458-0502
Fax: 61-2-9793-2544
Fax: 55-11-884-9680
Fax: 1-905-829-3333
Fax: 44-1635-569573
Fax: 49-2131-349-222
Fax: 822-554-6343
Fax: 52-5-368-0418
Fax: 65-284-6089