

Service Manual

Digital Surround Processor

Processor

SH-AC300

Colour

(K) ... Black Type

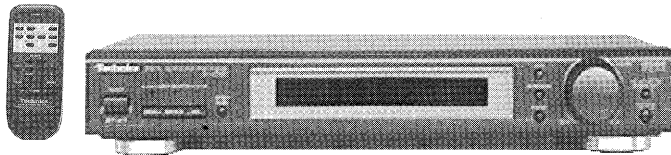

Area

Suffix for Model No.	Area	Colour
(PP)	U.S.A. and Canada	(K)

* Manufactured under license from Dolby Laboratories Licensing Corporation.
"Dolby", "AC-3", "Pro Logic" and the double-D symbol are trade marks of Dolby Laboratories.

Specifications

AUDIO

Output voltage / Impedance	2 V (at 0 dB) / 1 kΩ
Input Impedance	
LINE	22 kΩ
COAXIAL	75 Ω
Frequency response	
FRONT L/R, CENTER, SURROUND L/R (LARGE)	20 Hz - 20 kHz, ±1 dB
Delay time	
AC - 3	
CENTER	0 - 5 ms
SURROUND L/R	0 - 15 ms
DOLBY PRO LOGIC SURROUND L/R	15 - 30 ms
Total harmonics distortion	
FRONT L/R (1 kHz, 0 dB, PCM)	0.007%
Dynamic range	90 dB
S/N (IHF A)	96 dB

Load impedance

More than 10 kΩ

GENERAL

Power supply	AC 120 V, 60 Hz
Power consumption	15 W
	(In standby condition : 4 W)
Dimensions (W x H x D)	430 x 69.4 x 301.4 mm
	(16 ¹⁵ / ₁₆ "x2 ⁴⁷ / ₆₄ "x11 ⁵⁵ / ₆₄ ")
Weight	2.6 kg (5.7 lb)

Notes :

Specifications are subject to change without notice.
Weight and dimensions are approximate.

Contents

	Page		Page
SAFETY PRECAUTIONS	2	WIRING CONNECTION DIAGRAM	15
OPERATION CHECKS AND MAIN COMPONENT REPLACEMENT	2 & 3	CABINET PARTS LOCATION	16
TERMINAL FUNCTION OF IC's	3 & 4	REPLACEMENT PARTS LIST	17 & 18
SCHEMATIC DIAGRAM	4 ~ 10	RESISTORS & CAPACITORS	18 ~ 20
TERMINAL GUIDE OF ICs TRANSISTORS AND DIODES	10	PACKAGING	20
PRINTED CIRCUIT BOARD	11 ~ 14		

WARNING

This service information is designed for experience repair technicians only and is not designed for use by the general public. It does not contain warnings or cautions to advise non-technical individuals of potential dangers in attempting to service a product. Products powered by electricity should be serviced or repaired only by experienced professional technicians. Any attempt to service or repair the product or products dealt with in this service information by anyone else could result in serious injury or death.

■ Safety Precautions (This "Safety Precaution" is applied only in U.S.A.)

1. Before servicing, unplug the power cord to prevent an electric shock .
2. When replacing parts, use only manufacturer's recommended components for safety .
3. Check the condition of the power cord. Replace if wear or damage is evident .
4. After servicing ,be sure to restore the lead dress, insulation barriers ,insulation papers ,shields ,etc .
5. Before returning the serviced equipment to the customer, be sure to make the following insulation resistance test to prevent the customer from being exposed to a shock hazard .

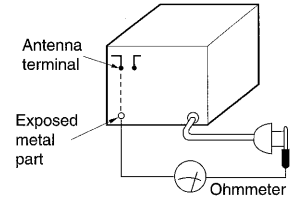

Fig. 1
Resistance = $3M\Omega - 5.2M\Omega$

• Insulation Resistance Test

1. Unplug the power cord and short the two prongs of the plug with a jumper wire .
2. Turn on the power switch .
3. Measure the resistance value with ohmmeter between the jumper AC plug and each exposed metal cabinet part ,such as screwheads, antenna ,control shafts ,handle brackets , etc . Equipment with antenna terminals should read between $3M\Omega$ and $5.2M\Omega$ to all exposed parts* .(Fig. 1) Equipment without antenna terminals should read approximately infinity to all exposed parts . (Fig. 2)
*Note :Some exposed parts may be isolated from the chassis by design. These will read infinity .
4. If the measurement is outside the specified limits ,there is a possibility of a shock hazard .The equipment should be repaired and rechecked before it is returned to the customer .

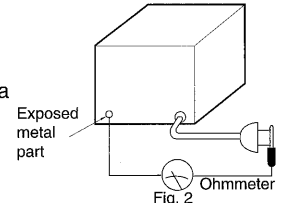

Fig. 2
Resistance = Approx ∞

■ Operation Checks and Main Component Replacement Procedures

" **ATTENTION SERVICER** " Some chassis component may have sharp edges. Be careful when disassembling and servicing.

1. This section describes procedures for checking the operation of the major printed circuit boards and replacing the main components.
2. For reassembly after operation checks or replacement, reverse the respective procedures.
Special reassembly procedures are described only when required.
3. Select items from the following index when checks or replacement are required.

• Contents

• Checking Procedure for each major P.C.B.	page 2 ~ 3
---	---------------

■ Checking Procedure for Major P.C.B.

1. Checking of the Control , Display and Power Switch P.C.B.

Step 1
a X 4

Step 2
b X 1

Step 3
Remove the top cabinet.

Step 4
b X 7

Step 5
Release the two rear claw and pull out the back panel

Control Panel P.C.B. (Solder Side)

Display P.C.B. (Solder Side)

Power Switch P.C.B. (Solder Side)

Claw

Claw

Legend:
a [SNE2129-1] (Black)
b [XTBS3+8JFZ1] (Black)

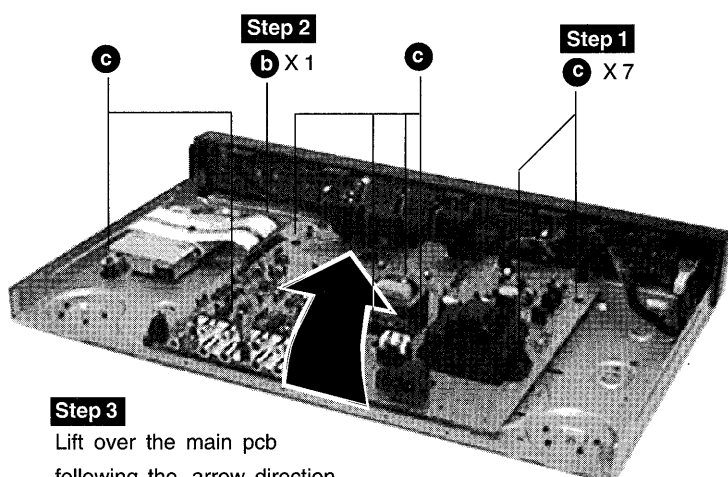

2. Checking of the AC-3 Module and Main P.C.B.

**Step 3**

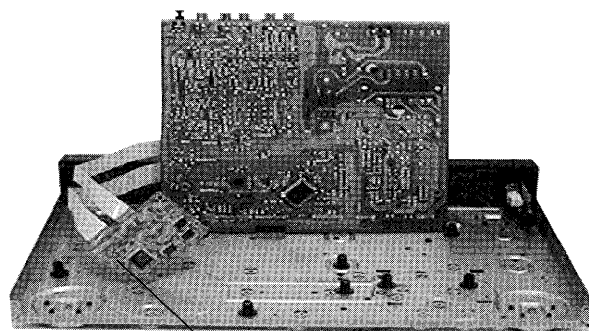
Lift over the main pcb following the arrow direction.



AC-3 Module P.C.B.
(Solder Side)

-  **b** [XTBS3+8JFZ1]
(Black)
-  **c** [XTB3+20JFZ1]
(Black)
-  **d** [XYN26+C6]
(Brass)

Main P.C.B.
(Solder Side)

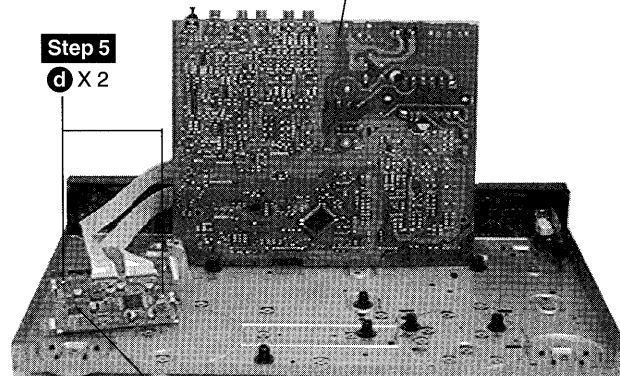
**Step 5**

d X 2

Step 4

Flip over the AC-3 module pcb as shown.

Step 6

Remove the shield from AC-3 module pcb.

Terminal Functions Of IC's

• IC901 (M38B53M4051F) System Microprocessor

Pin No.	Mark	I/O	Function
1	XCS	O	Chip select : XLJ93LC46
2	SK	O	Serial clock : XLJ93LC46
3	DI	O	Serial data output : XLJ93LC46
4	DO	I	Serial data input : XLJ93LC46
5~6	STB1~STB2	O	Strobe (C/W) : TC9212P
7~8	RA~RB	I	Rotary encoder input A~B
9	--	I	Unused to be connected to GND
10	RESET	I	Reset input
11	CK	O	Serial clock : TC9212P
12	DATA	O	Serial data output : TC9212P
13	VSS	--	GND terminal
14	XIN	--	Crystal oscillator terminal
15	XOUT	--	(4 MHz)
16	VDD/VCC	--	Power supply terminal +5V
17~18	DIGITAL1~2	O	Input selector indicator LED
19	LINE	O	LINE DIRECT indicator LED
20	STANDBY	O	Standby LED

Pin No.	Mark	I/O	Function
21	POWERSW	I	Mechanical power source switch reader
22	REMOTE	I	Remote control input
23	HOLD	I	Power outage detection
24	POWER	O	Power supply relay
25~27	A4053A~C	O	Analog switch (4053) control A~C
28	VEE	--	-VP
29~30	MUTEA / S	O	Software muting
31~40	DIG10~DIG1	O	FL digit output
41~56	SEG1~SEG16	O	FL segment signal output
57	INIT	I	Initial setting diode reading input
58	--	I	Unused, connected to Vcc via resistance
59	PDN	O	Reset / power down : CS4226
60	OVLERR	I	Overflow / error : CS4226
61	FRQ0	I	Sampling frequency : CS4226
62	FRQ1	I	Sampling frequency : CS4226
63	AC3	I	AC-3 bitstream : CS4226
64	AUDIO	I	PCM audio : CS4226

Pin No.	Mark	I/O	Function
65	CCS	O	Chip select : CS4226
66	CCLK	O	Serial clock : CS4226
67	CDIN	O	Serial data input : CS4226
68	CDOUT	I	Serial data output : CS4226
69	SS	O	Chip select : DSP56009
70	SCK	O	Serial clock : DSP56009 / TC9332F
71	MOSI	O	Serial data output : DSP56009 / TC9332F
72	MISO	O	Serial data input : DSP56009

Pin No.	Mark	I/O	Function
73	AVSS	-	GND for A/D converter
74	VREF	-	Reference voltage for A/D conversion
75	MRESET	O	Reset output : DSP56009
76	IFCD	O	Command / data select : TC9332F
77	TCS	O	Chip select : TC9332F
78	TRST	O	Reset output : TC9332F
79	KEY1	A/D	Key input 1
80	KEY2	A/D	Key input 2



■ Schematic Diagram

(All schematic diagrams may be modified at any time with the development of new technology)

Note :

- | | | | | | |
|--------|---|--------------|---------|---|----------------|
| • S701 | : | Power switch | • S906 | : | Pro-logic |
| • S901 | : | Digital 1 | • S907 | : | Stereo |
| • S902 | : | Digital 2 | • S908 | : | Channel select |
| • S903 | : | Line switch | • S909 | : | Speaker select |
| • S904 | : | RE-EQ switch | • VR901 | : | Volume control |
| • S905 | : | AC-3 switch | | | |

• Signal line

 : +B line
  : -B line
  : Main signal line

•The voltage value and waveforms are the reference voltage of this unit measured by DC electronic voltmeter (high impedance) and oscilloscope on the basis of chassis. Accordingly, there may arise some error in voltage values and waveforms depending upon the internal impedance of the tester or the measuring unit.

• Importance safety notice:

Components identified by Δ mark have special characteristics important for safety. Furthermore, special parts which have purposes of fire retardant (resistors), high-quality sound (capacitors), low-noise (resistors), etc. are used. When replacing any of components, be sure to use only manufacturer's specified parts shown in the parts list.

Caution !

- IC, LSI and VLSI are sensitive to static electricity.
 Secondary trouble can be prevented by taking care during repair.
- Cover the parts boxes made of plastics with aluminium foil.
 - Ground the soldering iron.
 - Do not touch the pins of IC, LSI or VLSI with fingers directly.
 - Put a conductive mat on the work table.

CAUTION : FOR CONTINUED PROTECTION AGAINST FIRE HAZARD, REPLACE ONLY WITH SAME TYPE F1 800mA 125V FUSE.



RISK OF FIRE-REPLACE FUSE AS MARKED.

FUSE CAUTION

 These symbols located near the fuse indicates that the fuse used is a fast operating type. For continued protection against fire hazard, replace with the same type fuse. For fuse rating, refer to the marking adjacent to the symbol.

 Ce symbole indique que le fusible utilisé est à rapide. Pour une protection permanente, n' utiliser que des fusibles de même type. Ce dernier est indiqué là où le présent symbole est apposé.

B FL CIRCUIT

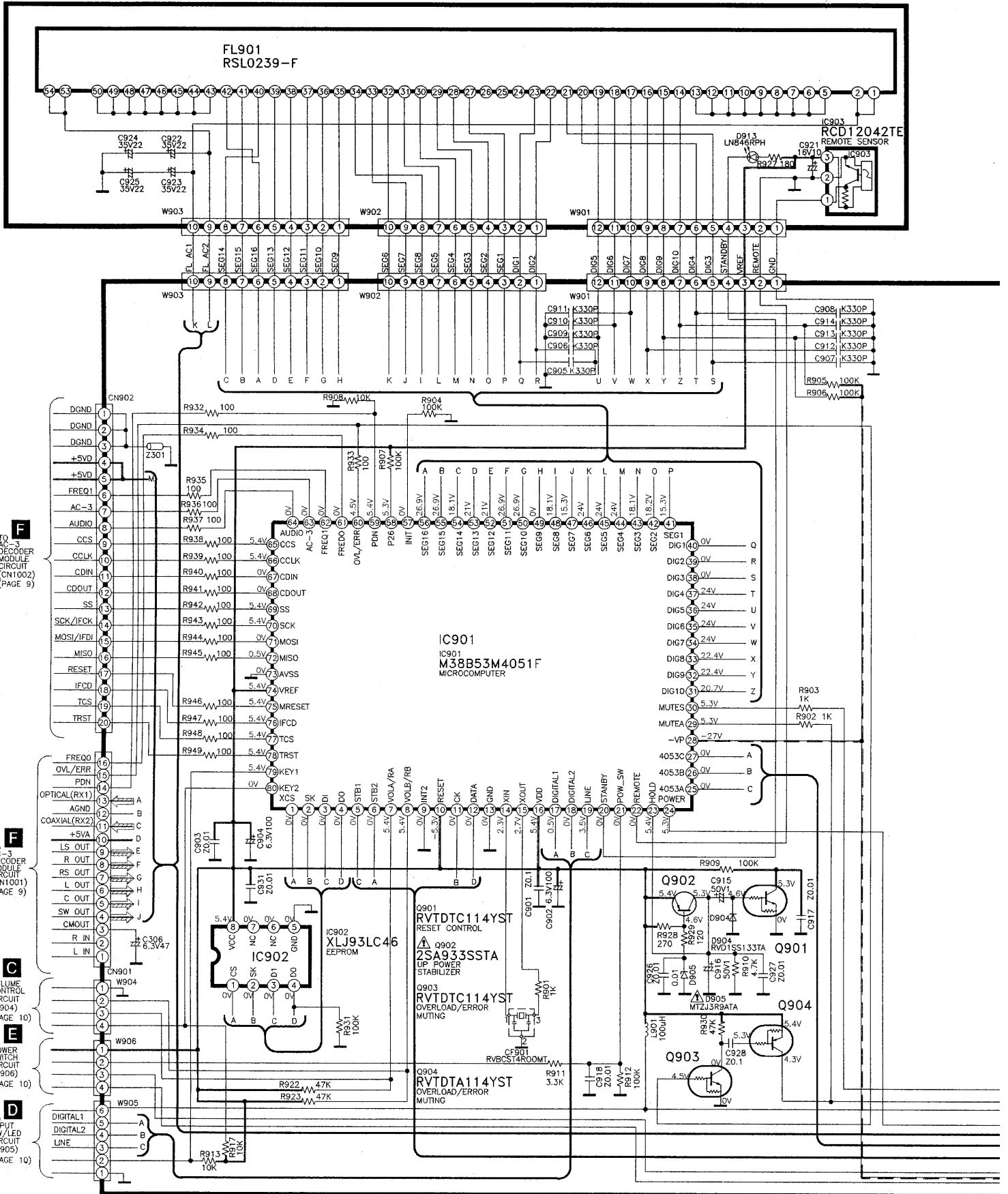

A MAIN CIRCUIT

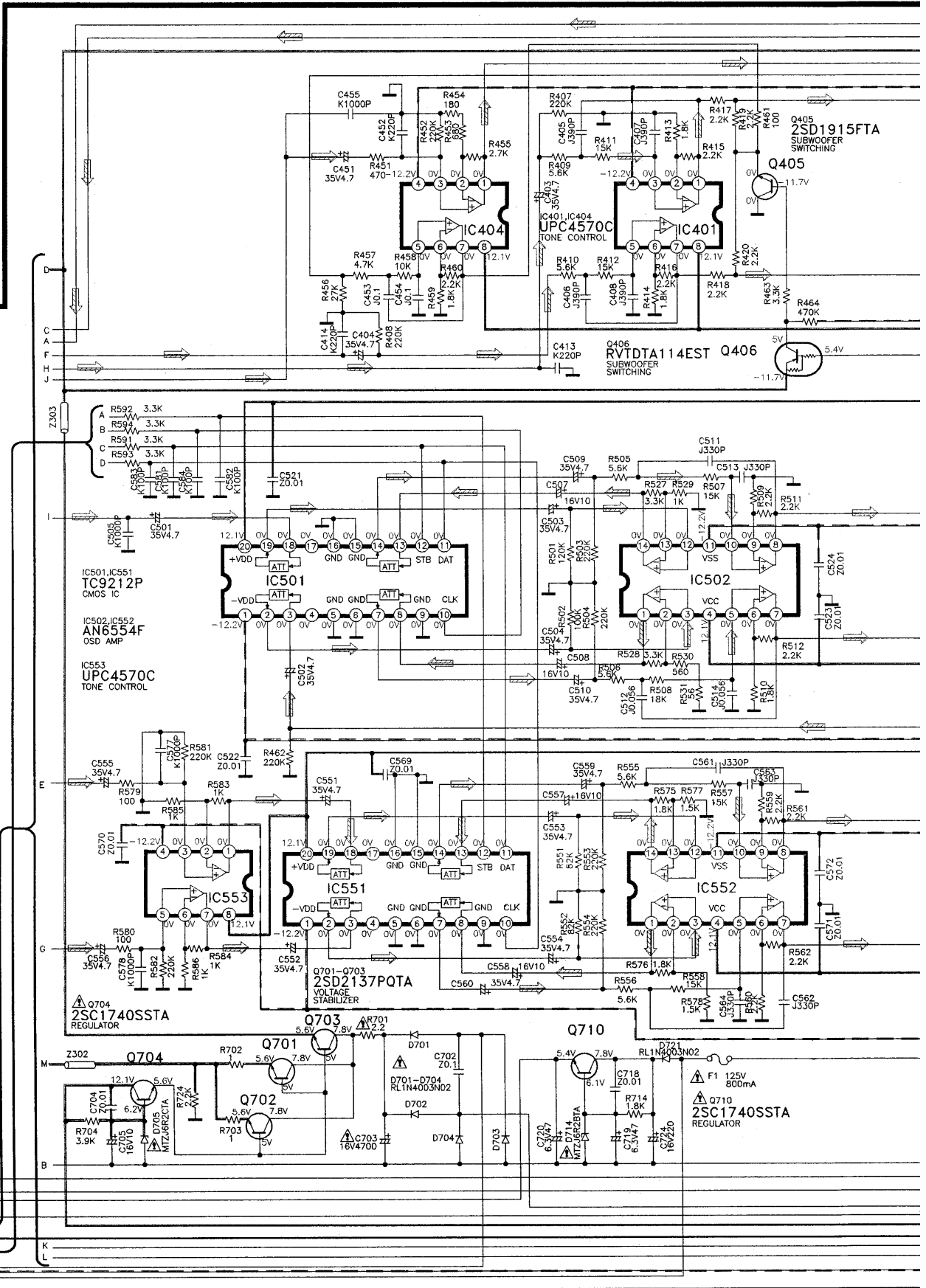

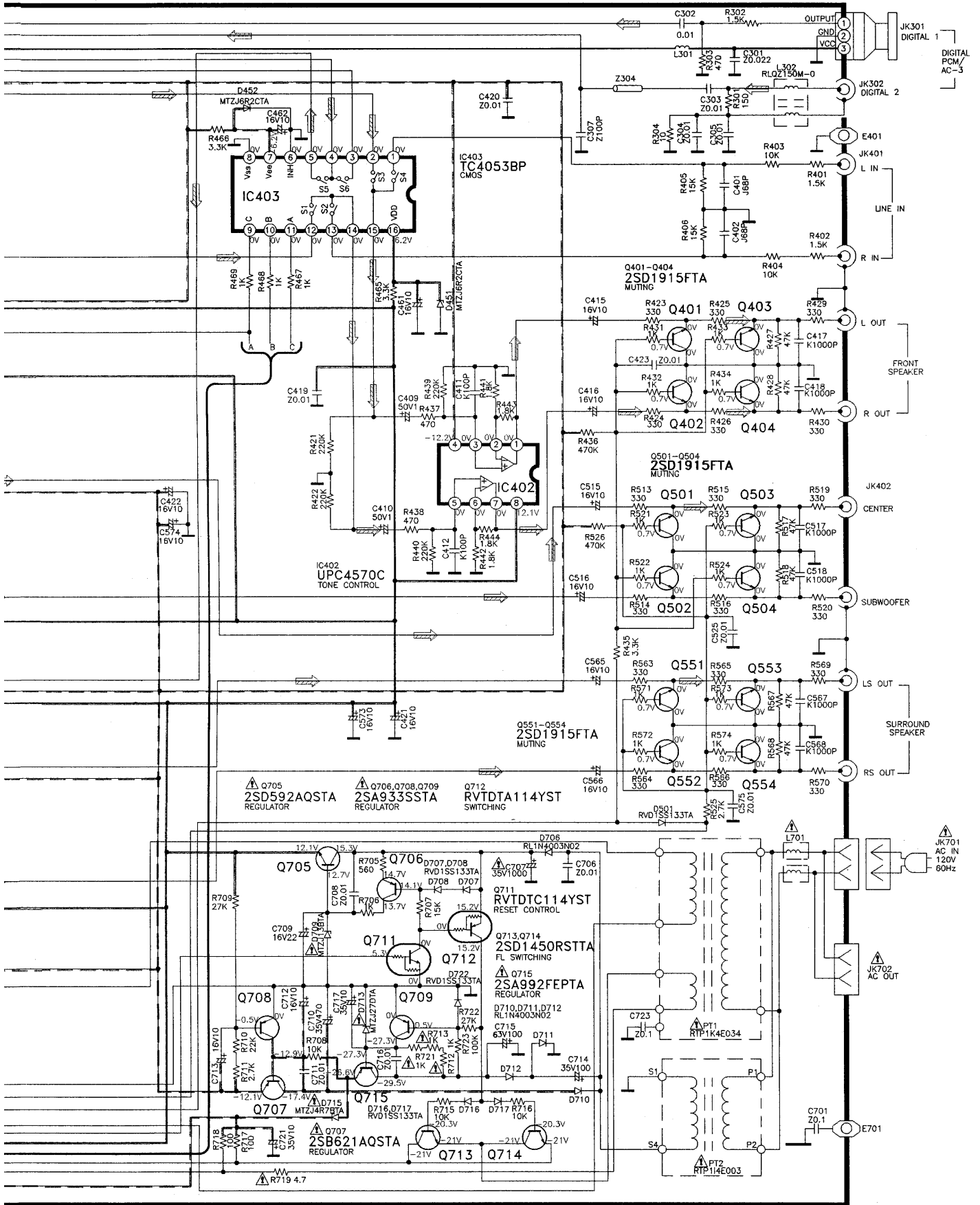

F DECODER CIRCUIT

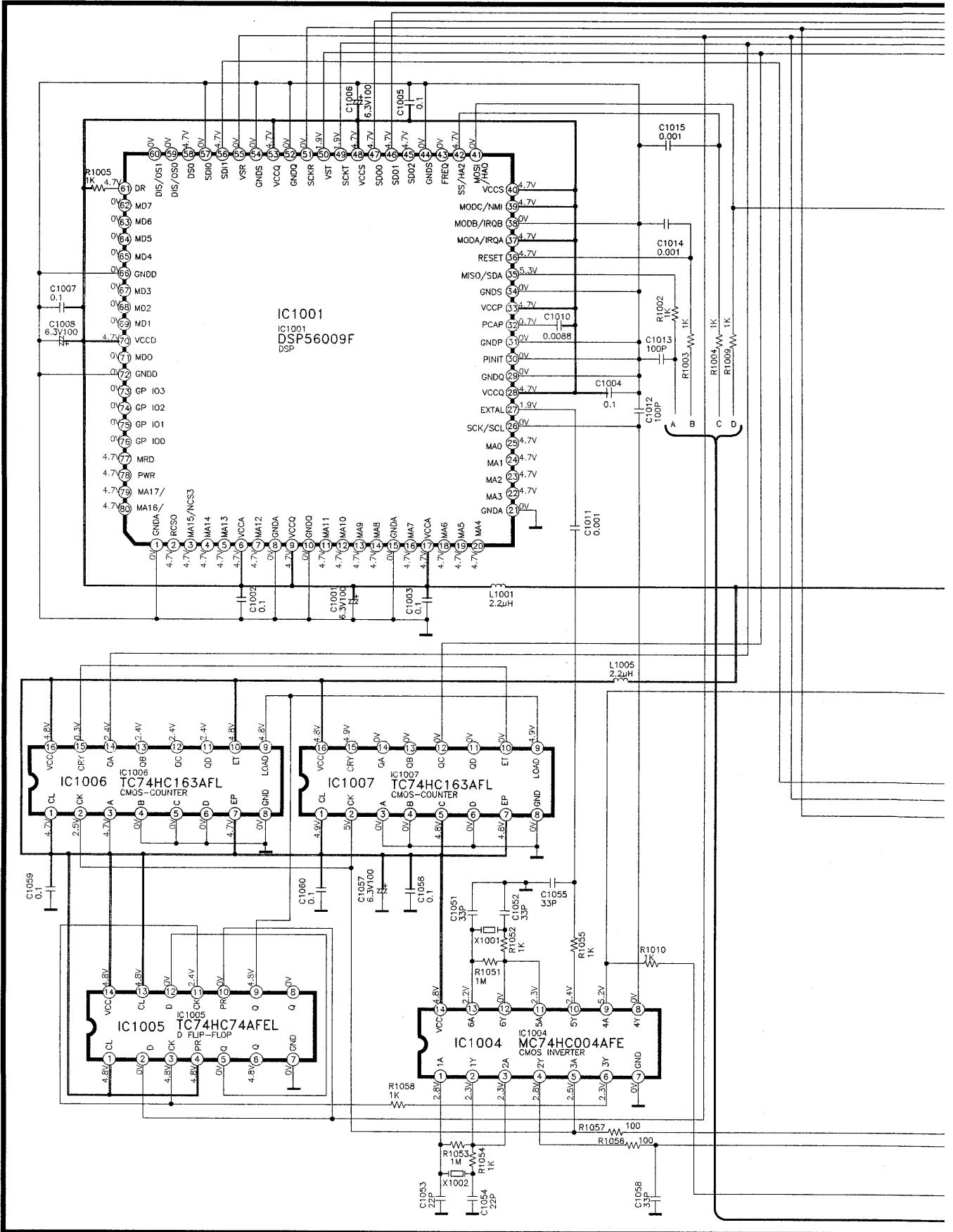

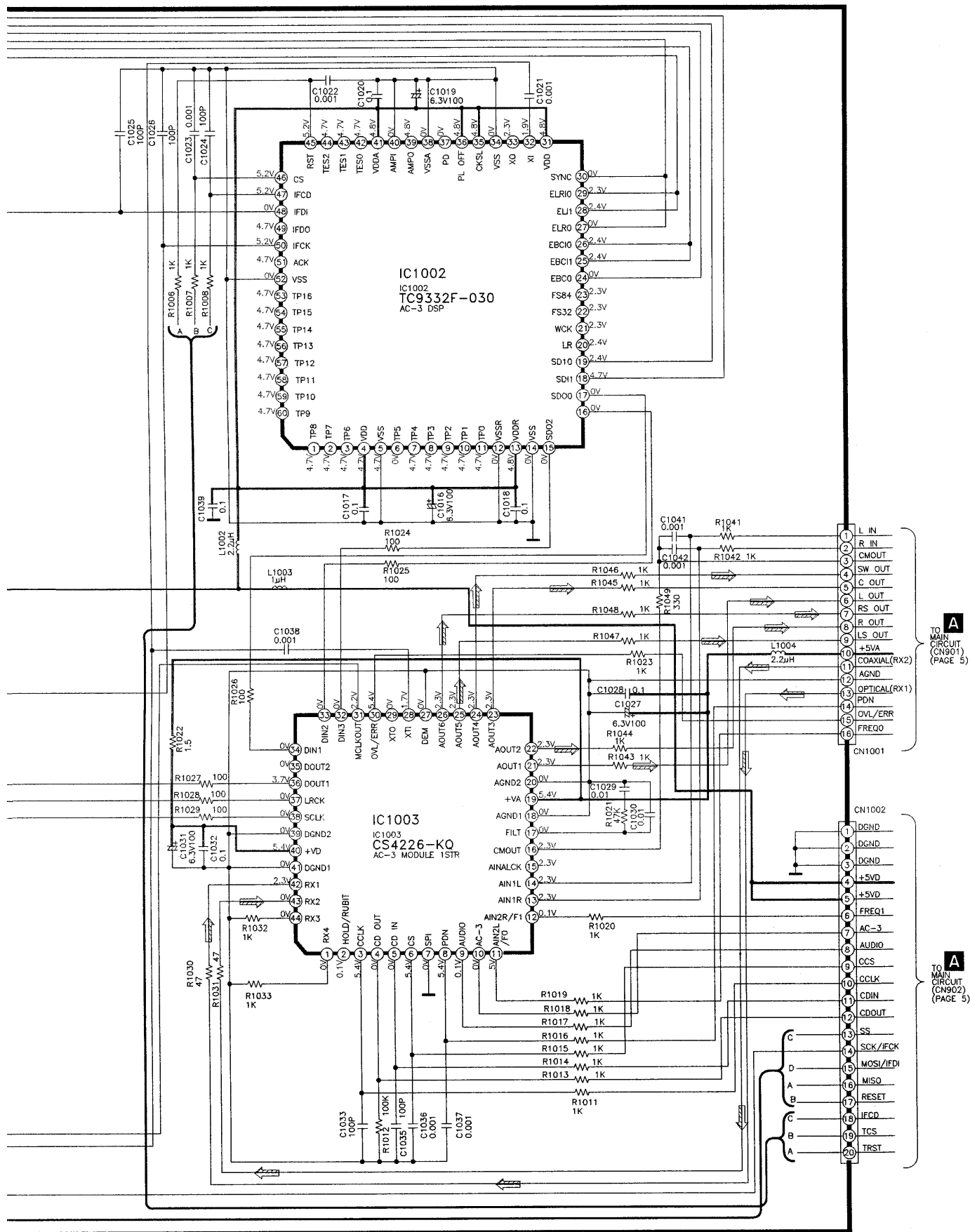

C VOLUME CONTROL CIRCUIT

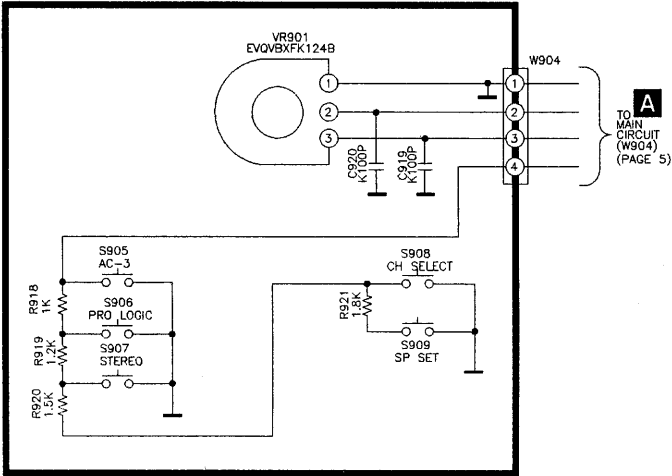

D INPUT SW/LED CIRCUIT

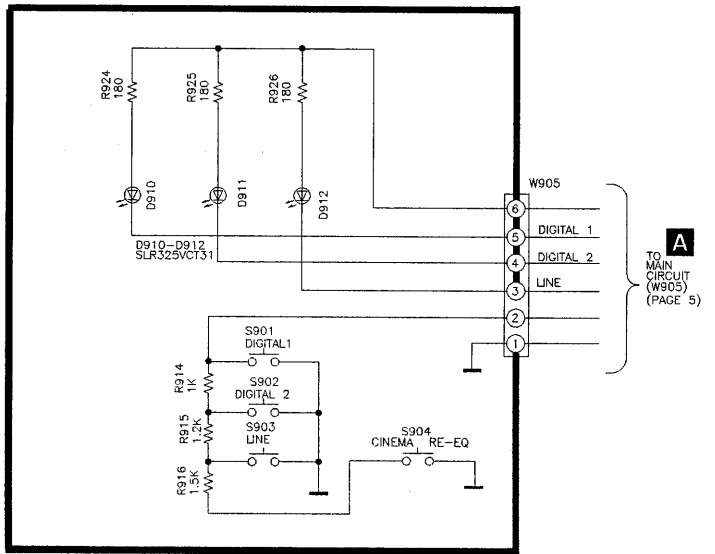

E POWER SW CIRCUIT

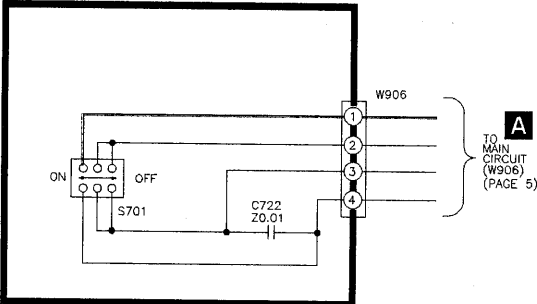

Terminal Guide of IC's, Transistors and Diodes

<p>UPC4570C</p>	<p>XLJ93LC46</p>	<p>AN6554F</p>	<p>M38B53M4051F (80 Pin)</p>	<p>TC4053BP</p>	<p>TC9212P</p>
<p>RVD1SS133TA</p>	<p>RL1N4003N02</p>	<p>2SD1915FTA 2SD1450RSTTA</p>	<p>2SD592AQSTA 2SA992FEPTA 2SB621AQSTA</p>	<p>2SD2137PQTA</p>	<p>LN846RPH</p>
<p>SLR325VCT31</p>	<p>RCD12042TE</p>	<p>MTZJ27DTA MTZJ13BTA MTZJ3R9ATA MTZJ4R7BTA MTZJ6R2BTA MTZJ6R2CTA</p>	<p>2SA933SSTA 2SC1740SSTA RVTDTA114EST RVTDTA114YST RVTDTCT114YST</p>		

■ Printed Circuit Board

■ C VOLUME P.C.B. (REP2499A-M)

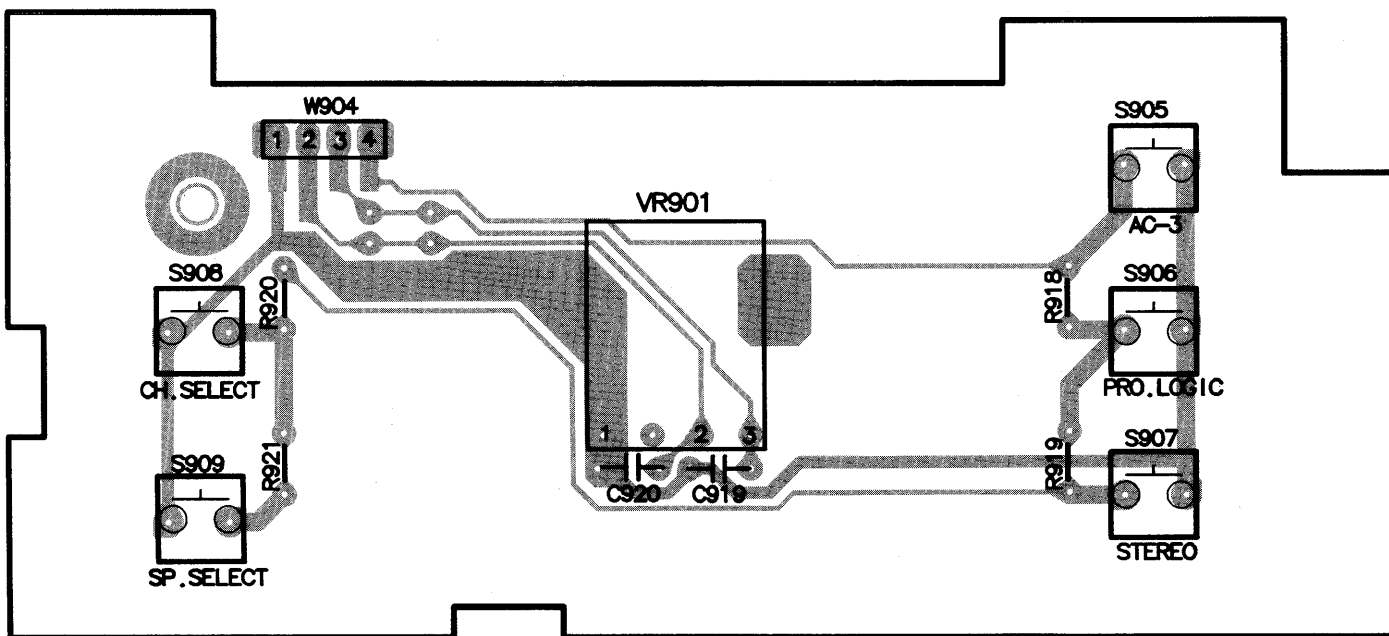

■ D INPUT SWITCH / LED P.C.B. (REP2499A-M)

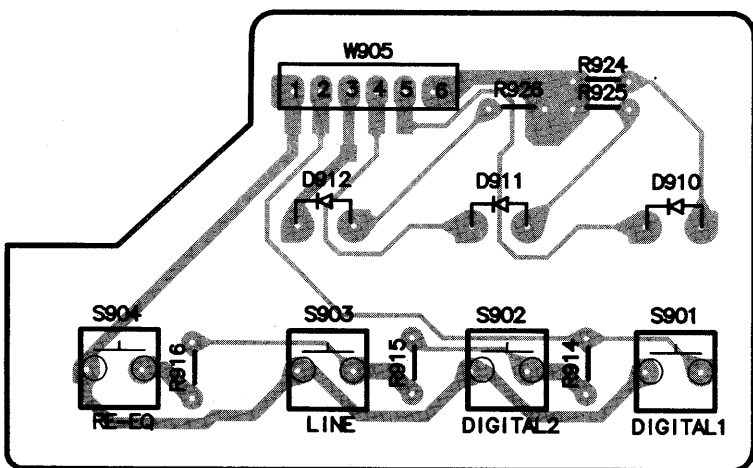

■ E POWER SWITCH P.C.B. (REP2499A-M)

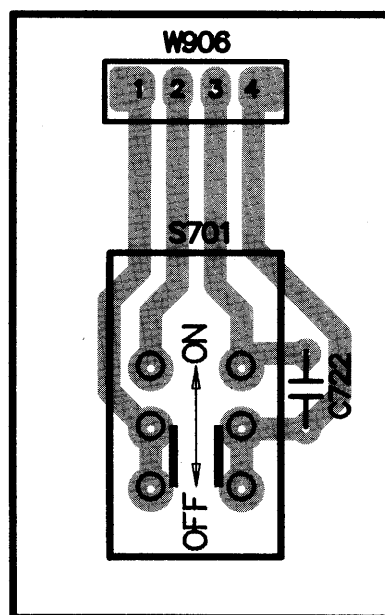

CAUTION
RISK OF ELECTRIC SHOCK
 AC voltage line. Please do not touch this portion.

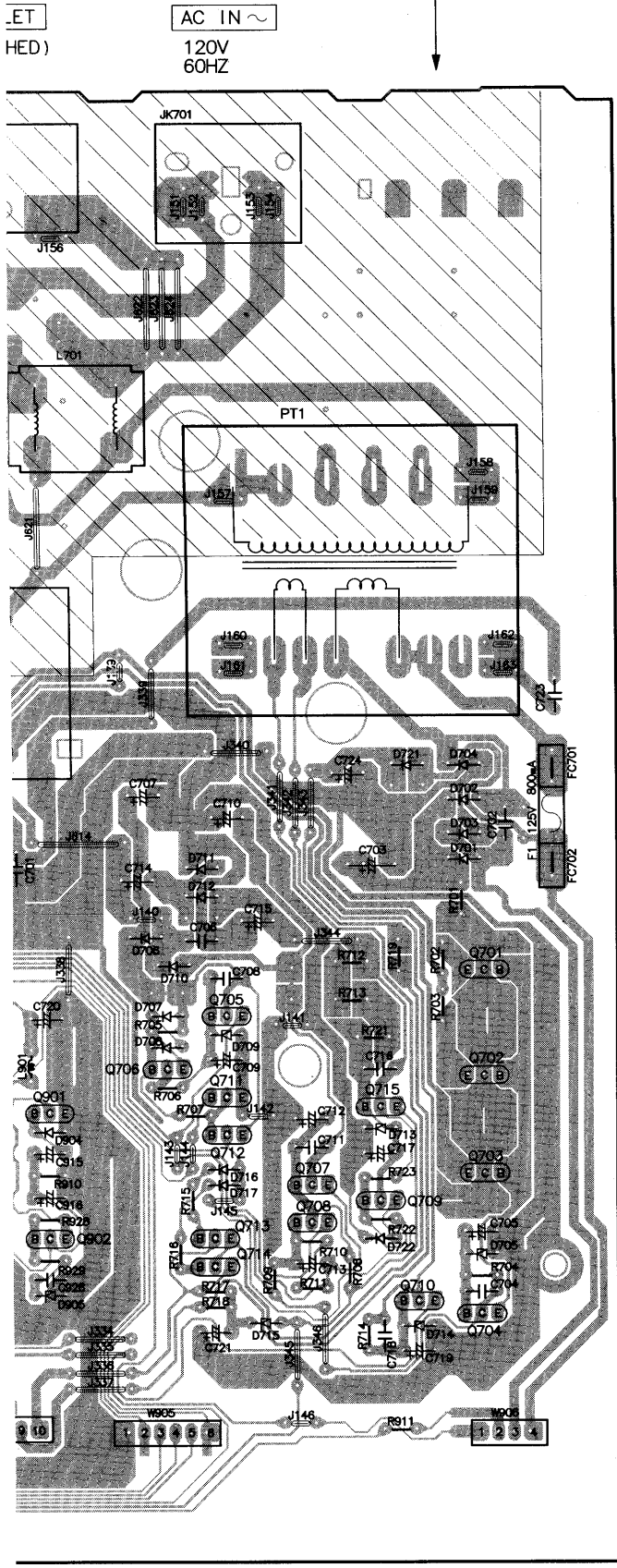

B FL P.C.B.
(REP2499A-M)

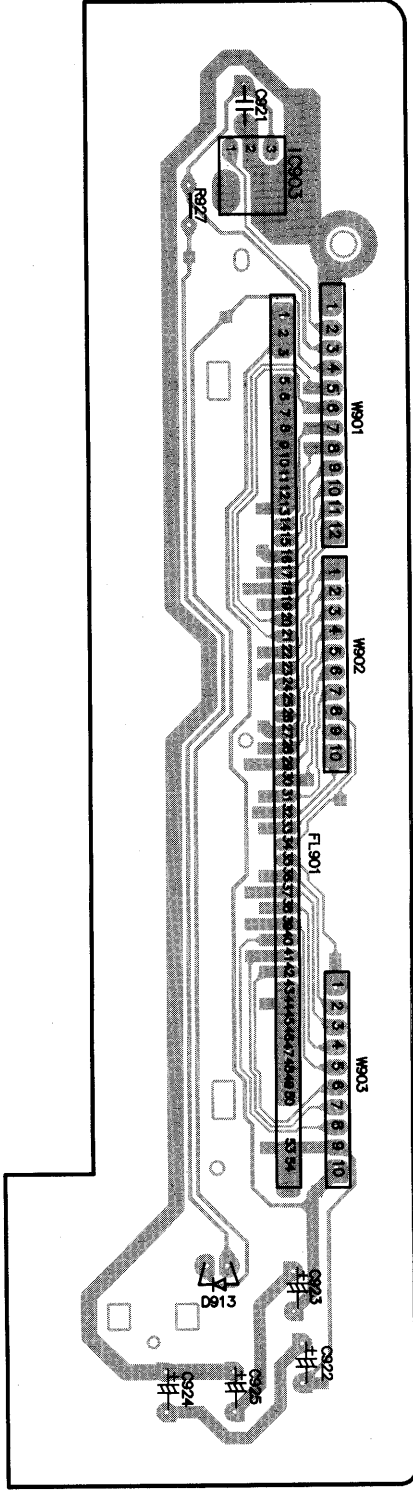

■ Wiring Connection Diagram

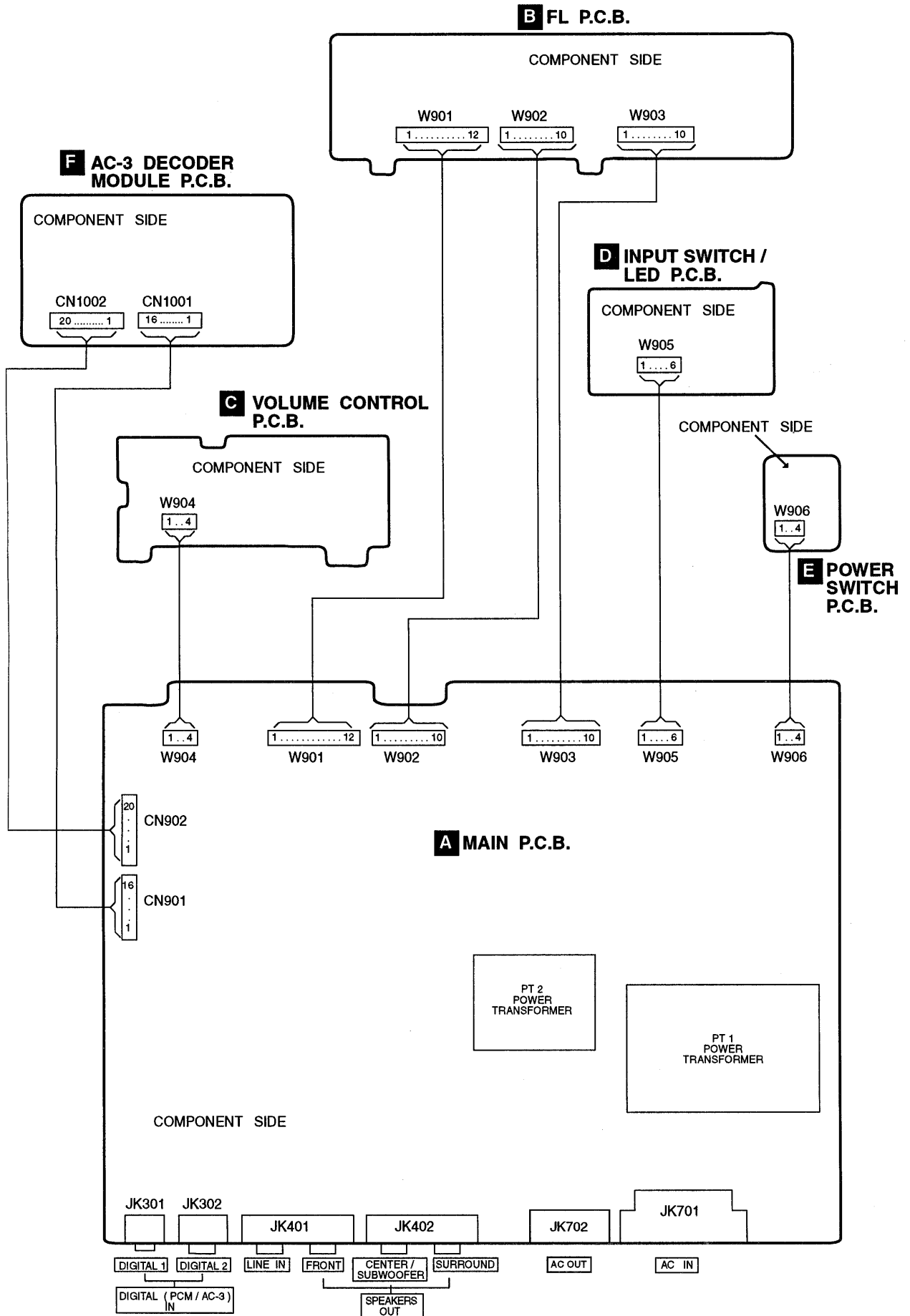

■ Cabinet Parts Location

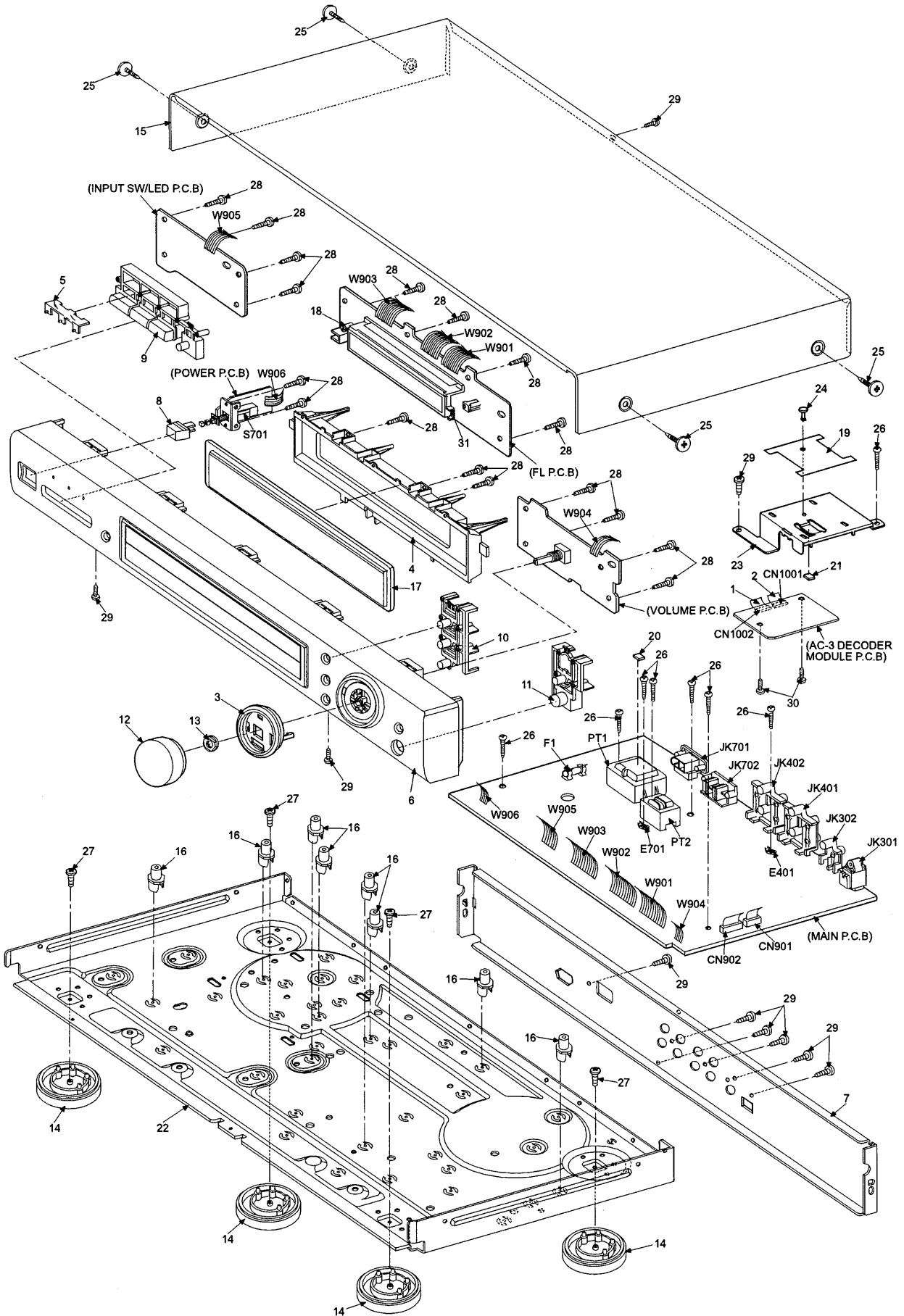

Replacement Parts List

Notes: * Important safety notice :

 Components identified by  mark have special characteristics important for safety.

Furthermore, special parts which have purposes of fire-retardant (resistors), high-quality sound (capacitors), low-noise (resistors), etc. are used. When replacing any of components, be sure to use only manufacturer's specified parts shown in the parts list.

 * The parenthesized in the Remarks columns specify the areas. (Refer to the cover page for area.)
 Parts without these indication can be used for all areas.

* The "(SF)" mark denotes the standard part.

* [M] in Remarks column indicates parts that are supplied by MESA.

* Remote Control Unit : Supply period for three years from terminal of production.

Ref No.	Part No.	Part Name & Description	Remarks	Ref No.	Part No.	Part Name & Description	Remarks	Ref No.	Part No.	Part Name & Description	Remarks
		CABINET AND CHASSIS		IC501	TC9212P	IC, CMOS	[M]	Q715	2SA992FEPTA	TRANSISTOR	[M] 
				IC502	AN6554F	IC, OSD AMP	[M]	Q901	RVTDTTC114YST	TRANSISTOR	[M]
1	REE0785-1	FFC	[M]	IC551	TC9212P	IC, CMOS	[M]	Q902	2SA933SSTA	TRANSISTOR	[M] 
2	REE0786-1	FFC	[M]	IC552	AN6554F	IC, OSD AMP	[M]	Q903	RVTDTTC114YST	TRANSISTOR	[M]
3	RGK0747-S	VOL RING	[M]	IC553	UPC4570C	IC, TONE CONTROL	[M]	Q904	RVTDTA114YST	TRANSISTOR	[M]
4	RFKNAC300PPK	WINDOW STAGE ASS'Y	[M]	IC901	M38B53M4051F	IC, MICOM	[M]			DIODES	
5	RGL0369-Q	PANEL LIGHT	[M]	IC902	XLJ93LC46	IC, EEPROM	[M]				
6	RFKAC300PPK	FRONT PANEL ASS'Y	[M]	IC903	RCD12042TE	IC, REMOTE SENSOR	[M]				
7	RGR0181C-A	REAR PANEL	[M]					D451	MTZJ6R2CTA	DIODE	[M]
8	RGU0890-K	BUTTON	[M]			TRANSISTORS		D452	MTZJ6R2CTA	DIODE	[M]
9	RGU1541-K	BUTTON (L)	[M]					D501	RVD1SS133TA	DIODE	[M]
10	RGU1542-K	BUTTON (C)	[M]	Q401	2SD1915FTA	TRANSISTOR	[M]	D701	RL1N4003N02	DIODE	[M] 
11	RGU1543-K	BUTTON (R)	[M]	Q402	2SD1915FTA	TRANSISTOR	[M]	D702	RL1N4003N02	DIODE	[M] 
12	RGW0229-K	KNOB	[M]	Q403	2SD1915FTA	TRANSISTOR	[M]	D703	RL1N4003N02	DIODE	[M] 
13	RHN90001	M9 NUT	[M]	Q404	2SD1915FTA	TRANSISTOR	[M]	D704	RL1N4003N02	DIODE	[M] 
14	RKA0079-A	FOOT	[M]	Q405	2SD1915FTA	TRANSISTOR	[M]	D705	MTZJ6R2CTA	DIODE	[M] 
15	RKM0032-K	TOP CABINET	[M]	Q406	RVTDTA114EST	TRANSISTOR	[M]	D706	RL1N4003N02	DIODE	[M]
16	RKQ0089-J	PCB HOLDER	[M]	Q501	2SD1915FTA	TRANSISTOR	[M]	D707	RVD1SS133TA	DIODE	[M]
17	RKW0518-Q	FL WINDOW	[M]	Q502	2SD1915FTA	TRANSISTOR	[M]	D708	RVD1SS133TA	DIODE	[M]
18	RMN0447	LED SUPPORT	[M]	Q503	2SD1915FTA	TRANSISTOR	[M]	D709	MTZJ13BTA	DIODE	[M] 
19	RMA1098	HOLDING PLATE	[M]	Q504	2SD1915FTA	TRANSISTOR	[M]	D710	RL1N4003N02	DIODE	[M]
20	RMG0145	TRANSFORMER RUBBER	[M]	Q551	2SD1915FTA	TRANSISTOR	[M]	D711	RL1N4003N02	DIODE	[M]
22	RMK0174-7	BOTTOM CHASSIS	[M]	Q552	2SD1915FTA	TRANSISTOR	[M]	D712	RL1N4003N02	DIODE	[M]
23	RSC0482	SHIELD	[M]	Q553	2SD1915FTA	TRANSISTOR	[M]	D713	MTZJ27DTA	DIODE	[M] 
24	SHR9112	PLASTIC RIVET	[M]	Q554	2SD1915FTA	TRANSISTOR	[M]	D714	MTZJ6R2BTA	DIODE	[M] 
25	SNE2129-1	SCREW (CABINET)	[M]	Q701	2SD2137PQTA	TRANSISTOR	[M]	D715	MTZJ4R7BTA	DIODE	[M] 
26	XTB3+20JFZ	SCREW	[M]	Q702	2SD2137PQTA	TRANSISTOR	[M]	D716	RVD1SS133TA	DIODE	[M]
27	XTB3+6G	SCREW	[M]	Q703	2SD2137PQTA	TRANSISTOR	[M]	D717	RVD1SS133TA	DIODE	[M]
28	XTBS26+10J	SCREW (FRONT)	[M]	Q704	2SC1740SSTA	TRANSISTOR	[M] 	D721	RL1N4003N02	DIODE	[M]
29	XTBS3+8JFZ1	SCREW	[M]	Q705	2SD592AQSTA	TRANSISTOR	[M] 	D722	RVD1SS133TA	DIODE	[M]
30	XYN26+C6	SCREW	[M]	Q706	2SA933SSTA	TRANSISTOR	[M] 	D904	RVD1SS133TA	DIODE	[M]
31	RMN0372	FL HOLDER	[M]	Q707	2SB621AQSTA	TRANSISTOR	[M] 	D905	MTZJ3R9ATA	DIODE	[M] 
				Q708	2SA933SSTA	TRANSISTOR	[M] 	D910	SLR325VCT31	DIODE	[M]
		INTEGRATED CIRCUITS		Q709	2SA933SSTA	TRANSISTOR	[M] 	D911	SLR325VCT31	DIODE	[M]
				Q710	2SC1740SSTA	TRANSISTOR	[M] 	D912	SLR325VCT31	DIODE	[M]
IC401	UPC4570C	IC, TONE CONTROL	[M]	Q711	RVTDTTC114YST	TRANSISTOR	[M]	D913	LN846RPH	DIODE	[M]
IC402	UPC4570C	IC, TONE CONTROL	[M]	Q712	RVTDTA114YST	TRANSISTOR	[M]				
IC403	TC4053BP	IC, CMOS	[M]	Q713	2SD1450RSTTA	TRANSISTOR	[M]				
IC404	UPC4570C	IC, TONE CONTROL	[M]	Q714	2SD1450RSTTA	TRANSISTOR	[M]				

Ref No.	Part No.	Part Name & Description	Remarks	Ref No.	Part No.	Part Name & Description	Remarks	Ref No.	Part No.	Part Name & Description	Remarks
		VARIABLE RESISTORS		PT2	RTP114C002	POWER TRANSFORMER [M]△		FC702	EYF52BC	FUSE HOLDER	[M]
VR901	EVQVBXFK124B	VR, VOLUME	[M]			COMPONENT COMBINATION				JACKS	
		SWITCHES		Z301	BL02RN2R62T4	EMI BEAD CORE	[M]	JK301	T0RX178A	JK, OPTICAL MODULE	[M]
S701	RSP2B023-A	SW, POWER	[M]	Z302	BL02RN2R62T4	EMI BEAD CORE	[M]	JK302	SJFD7-8	JK, RCA PIN	[M]
S901	EVQ21405R	SW, DIGITAL 1	[M]	Z303	BL02RN2R62T4	EMI BEAD CORE	[M]	JK401	SJF3069-4N	JK, LINE IN	[M]
S902	EVQ21405R	SW, DIGITAL 2	[M]	Z304	BL02RN2R62T4	EMI BEAD CORE	[M]	JK402	SJF3069-18N	JK, RCA PIN	[M]
S903	EVQ21405R	SW, LINE	[M]			CERAMIC FILTER		JK701	SJSD16-1	JK, AC INLET	[M]△
S904	EVQ21405R	SW, RE-EQ	[M]					JK702	RJS1A1602-2S	JK, AC OUTLET	[M]△
S905	EVQ21405R	SW, AC-3	[M]	CF901	RVBCST4R00MT	CERAMIC OSCILLATOR	[M]			PACKING MATERIALS	
S906	EVQ21405R	SW, PRO. LOGIC	[M]			DISPLAY TUBE		P1	RPG3471	PACKING CASE	[M]
S907	EVQ21405R	SW, STEREO	[M]					P2	RPN1058	POLYFOAM	[M]
S908	EVQ21405R	SW, CH. SELECT	[M]	FL901	RSL0239-F	FL	[M]	P3	SPP740	BAG	[M]
S909	EVQ21405R	SW, SP. SELECT	[M]			EARTH TERMINALS		P4	SPSD152	ACCESSORY BOX	[M]
		CONNECTORS								ACCESSORIES	
CN901	RJS2A3316	16P CONNECTOR	[M]	E401	SNE1004-2	EARTH TERMINAL	[M]	A1	EUR644378	REMOTE CONTROL	[M]
CN902	RJS2A3320	20P CONNECTOR	[M]	E701	SNE1004-2	EARTH TERMINAL	[M]	A1-1	UR64EC1822	REMOTE CON. COVER	[M]
		COILS & TRANSFORMERS				FUSE		A2	SJA172	AC CORD	[M]△(SF)
L301	RLQZP1R0KT-Y	AXIAL COIL	[M]	F1	XBA1C08NBAU	FUSE	[M]△	A3	RJL1P021B08	1P CORD	[M]
L302	RLQZ150M-0	CHOKE COIL	[M]			FUSE HOLDERS		A4	RJL2P004B08	STEREO CABLE	[M]
L701	RLQZ271M	AC LINE COIL	[M]△					A5	RQT3951-1Y	O/I BOOK	[M]
L901	RLQB101KTA-Y	CHOKE COIL	[M]	FC701	EYF52BC	FUSE HOLDER	[M]	A6	SJP2281	OPTICAL CABLE	[M]

■ Resistors & Capacitors

Notes : * Important safety notice:

Components identified by △ mark have special characteristics important for safety.

Furthermore, special parts which have purposes of fire-retardant (resistors), high-quality sound (capacitors), low-noise (resistors), etc. are used. When replacing any of components, be sure to use only manufacturer's specified parts shown in the parts list.

* Capacitor values are in microfarad (μF) unless specified otherwise, P=Pico-farads (pF) F=Farads (F)

* Resistors values are in ohms, unless specified otherwise, 1k=1,000(OHM), 1M=1,000k(OHM)

Ref No.	Part No.	Values&Remarks	Ref No.	Part No.	Values&Remarks	Ref No.	Part No.	Values&Remarks	Ref No.	Part No.	Values&Remarks
		RESISTORS	R406	ERDS2TJ153T	15K 1/4W [M]	R417	ERDS2TJ222T	2.2K 1/4W [M]	R428	ERDS2TJ473T	47K 1/4W [M]
			R407	ERDS2TJ224T	220K 1/4W [M]	R418	ERDS2TJ222T	2.2K 1/4W [M]	R429	ERDS2TJ331T	330 1/4W [M]
R301	ERDS2TJ151T	150 1/4W [M]	R408	ERDS2TJ224T	220K 1/4W [M]	R419	ERDS2TJ222T	2.2K 1/4W [M]	R430	ERDS2TJ331T	330 1/4W [M]
R302	ERDS2TJ152T	1.5K 1/4W [M]	R409	ERDS2TJ562T	5.6K 1/4W [M]	R420	ERDS2TJ222T	2.2K 1/4W [M]	R431	ERDS2TJ102T	1K 1/4W [M]
R303	ERDS2TJ471T	470 1/4W [M]	R410	ERDS2TJ562T	5.6K 1/4W [M]	R421	ERDS2TJ224T	220K 1/4W [M]	R432	ERDS2TJ102T	1K 1/4W [M]
R304	ERDS2TJ100T	10 1/4W [M]	R411	ERDS2TJ153T	15K 1/4W [M]	R422	ERDS2TJ224T	220K 1/4W [M]	R433	ERDS2TJ102T	1K 1/4W [M]
R401	ERDS2TJ152T	1.5K 1/4W [M]	R412	ERDS2TJ153T	15K 1/4W [M]	R423	ERDS2TJ331T	330 1/4W [M]	R434	ERDS2TJ102T	1K 1/4W [M]
R402	ERDS2TJ152T	1.5K 1/4W [M]	R413	ERDS2TJ182T	1.8K 1/4W [M]	R424	ERDS2TJ331T	330 1/4W [M]	R435	ERDS2TJ332T	3.3K 1/4W [M]
R403	ERDS2TJ103T	10K 1/4W [M]	R414	ERDS2TJ182T	1.8K 1/4W [M]	R425	ERDS2TJ331T	330 1/4W [M]	R436	ERDS2TJ474T	470K 1/4W [M]
R404	ERDS2TJ103T	10K 1/4W [M]	R415	ERDS2TJ222T	2.2K 1/4W [M]	R426	ERDS2TJ331T	330 1/4W [M]	R437	ERDS2TJ471T	470 1/4W [M]
R405	ERDS2TJ153T	15K 1/4W [M]	R416	ERDS2TJ222T	2.2K 1/4W [M]	R427	ERDS2TJ473T	47K 1/4W [M]	R438	ERDS2TJ471T	470 1/4W [M]

Ref No.	Part No.	Values & Remarks	Ref No.	Part No.	Values & Remarks	Ref No.	Part No.	Values & Remarks	Ref No.	Part No.	Values & Remarks
R439	ERDS2TJ224T	220K 1/4W [M]	R524	ERDS2TJ102T	1K 1/4W [M]	R701	ERDS1FVJ2R2T	2.2 1/2W[M]△	R926	ERDS2TJ181T	180 1/4W [M]
R440	ERDS2TJ224T	220K 1/4W [M]	R525	ERDS2TJ272T	2.7K 1/4W [M]	R702	ERDS2TJ1R0T	1 1/4W [M]	R927	ERDS2TJ181T	180 1/4W [M]
R441	ERDS2TJ182T	1.8K 1/4W [M]	R526	ERDS2TJ474T	470K 1/4W [M]	R703	ERDS2TJ1R0T	1 1/4W [M]	R928	ERDS2TJ271T	270 1/4W [M]
R442	ERDS2TJ182T	1.8K 1/4W [M]	R527	ERDS2TJ332T	3.3K 1/4W [M]	R704	ERDS2TJ392T	3.9K 1/4W [M]	R929	ERDS2TJ121T	120 1/4W [M]
R443	ERDS2TJ182T	1.8K 1/4W [M]	R528	ERDS2TJ332T	3.3K 1/4W [M]	R705	ERDS2TJ561T	560 1/4W [M]	R930	ERDS2TJ473T	47K 1/4W [M]
R444	ERDS2TJ182T	1.8K 1/4W [M]	R529	ERDS2TJ102T	1K 1/4W [M]	R706	ERDS2TJ102T	1K 1/4W [M]	R931	ERDS2TJ104T	100K 1/4W [M]
R451	ERDS2TJ471T	470 1/4W [M]	R530	ERDS2TJ561T	560 1/4W [M]	R707	ERDS2TJ153T	15K 1/4W [M]	R932	ERDS2TJ101T	100 1/4W [M]
R452	ERDS2TJ224T	220K 1/4W [M]	R531	ERDS2TJ560T	56 1/4W [M]	R708	ERDS2TJ103T	10K 1/4W [M]	R933	ERDS2TJ101T	100 1/4W [M]
R453	ERDS2TJ681T	680 1/4W [M]	R551	ERDS2TJ823T	82K 1/4W [M]	R709	ERDS2TJ273T	27K 1/4W [M]	R934	ERDS2TJ101T	100 1/4W [M]
R454	ERDS2TJ181T	180 1/4W [M]	R552	ERDS2TJ823T	82K 1/4W [M]	R710	ERDS2TJ223T	22K 1/4W [M]	R935	ERDS2TJ101T	100 1/4W [M]
R455	ERDS2TJ272T	2.7K 1/4W [M]	R553	ERDS2TJ224T	220K 1/4W [M]	R711	ERDS2TJ272T	2.7K 1/4W [M]	R936	ERDS2TJ101T	100 1/4W [M]
R456	ERDS2TJ273T	27K 1/4W [M]	R554	ERDS2TJ224T	220K 1/4W [M]	R712	ERDS1FVJ102T	1K 1/2W[M]△	R937	ERDS2TJ101T	100 1/4W [M]
R457	ERDS2TJ472T	4.7K 1/4W [M]	R555	ERDS2TJ562T	5.6K 1/4W [M]	R713	ERDS1FVJ102T	1K 1/2W[M]△	R938	ERDS2TJ101T	100 1/4W [M]
R458	ERDS2TJ103T	10K 1/4W [M]	R556	ERDS2TJ562T	5.6K 1/4W [M]	R714	ERDS2TJ182T	1.8K 1/4W [M]	R939	ERDS2TJ101T	100 1/4W [M]
R459	ERDS2TJ182T	1.8K 1/4W [M]	R557	ERDS2TJ153T	15K 1/4W [M]	R715	ERDS2TJ103T	10K 1/4W [M]	R940	ERDS2TJ101T	100 1/4W [M]
R460	ERDS2TJ222T	2.2K 1/4W [M]	R558	ERDS2TJ153T	15K 1/4W [M]	R716	ERDS2TJ103T	10K 1/4W [M]	R941	ERDS2TJ101T	100 1/4W [M]
R461	ERDS2TJ101T	100 1/4W [M]	R559	ERDS2TJ222T	2.2K 1/4W [M]	R717	ERDS2TJ101T	100 1/4W [M]	R942	ERDS2TJ101T	100 1/4W [M]
R462	ERDS2TJ224T	220K 1/4W [M]	R560	ERDS2TJ222T	2.2K 1/4W [M]	R718	ERDS2TJ101T	100 1/4W [M]	R943	ERDS2TJ101T	100 1/4W [M]
R463	ERDS2TJ332T	3.3K 1/4W [M]	R561	ERDS2TJ222T	2.2K 1/4W [M]	R719	ERDS1FVJ4R7T	4.7 1/2W[M]△	R944	ERDS2TJ101T	100 1/4W [M]
R464	ERDS2TJ474T	470K 1/4W [M]	R562	ERDS2TJ222T	2.2K 1/4W [M]	R721	ERDS1FVJ102T	1K 1/2W[M]△	R945	ERDS2TJ101T	100 1/4W [M]
R465	ERDS2TJ332T	3.3K 1/4W [M]	R563	ERDS2TJ331T	330 1/4W [M]	R722	ERDS2TJ273T	27K 1/4W [M]	R946	ERDS2TJ101T	100 1/4W [M]
R466	ERDS2TJ332T	3.3K 1/4W [M]	R564	ERDS2TJ331T	330 1/4W [M]	R723	ERDS2TJ104T	100K 1/4W [M]	R947	ERDS2TJ101T	100 1/4W [M]
R467	ERDS2TJ102T	1K 1/4W [M]	R565	ERDS2TJ331T	330 1/4W [M]	R724	ERDS2TJ222T	2.2K 1/4W [M]	R948	ERDS2TJ101T	100 1/4W [M]
R468	ERDS2TJ102T	1K 1/4W [M]	R566	ERDS2TJ331T	330 1/4W [M]	R901	ERDS2TJ102T	1K 1/4W [M]	R949	ERDS2TJ101T	100 1/4W [M]
R469	ERDS2TJ102T	1K 1/4W [M]	R567	ERDS2TJ473T	47K 1/4W [M]	R902	ERDS2TJ102T	1K 1/4W [M]			
R501	ERDS2TJ124T	120K 1/4W [M]	R568	ERDS2TJ473T	47K 1/4W [M]	R903	ERDS2TJ102T	1K 1/4W [M]			CAPACITORS
R502	ERDS2TJ104T	100K 1/4W [M]	R569	ERDS2TJ331T	330 1/4W [M]	R904	ERDS2TJ104T	100K 1/4W [M]			
R503	ERDS2TJ224T	220K 1/4W [M]	R570	ERDS2TJ331T	330 1/4W [M]	R905	ERDS2TJ104T	100K 1/4W [M]	C301	ECBT1E223ZF5	0.022 25V [M]
R504	ERDS2TJ224T	220K 1/4W [M]	R571	ERDS2TJ102T	1K 1/4W [M]	R906	ERDS2TJ104T	100K 1/4W [M]	C302	ECBT1E103ZF5	0.01 25V [M]
R505	ERDS2TJ562T	5.6K 1/4W [M]	R572	ERDS2TJ102T	1K 1/4W [M]	R907	ERDS2TJ104T	100K 1/4W [M]	C303	ECBT1E103ZF5	0.01 25V [M]
R506	ERDS2TJ562T	5.6K 1/4W [M]	R573	ERDS2TJ102T	1K 1/4W [M]	R908	ERDS2TJ103T	10K 1/4W [M]	C304	ECBT1E103ZF5	0.01 25V [M]
R507	ERDS2TJ153T	15K 1/4W [M]	R574	ERDS2TJ102T	1K 1/4W [M]	R909	ERDS2TJ104T	100K 1/4W [M]	C305	ECBT1E103ZF5	0.01 25V [M]
R508	ERDS2TJ183T	18K 1/4W [M]	R575	ERDS2TJ182T	1.8K 1/4W [M]	R910	ERDS2TJ472T	4.7K 1/4W [M]	C306	ECEA0JKA470B	47 6.3V [M]
R509	ERDS2TJ222T	2.2K 1/4W [M]	R576	ERDS2TJ182T	1.8K 1/4W [M]	R911	ERDS2TJ332T	3.3K 1/4W [M]	C307	ECBT1H101KB5	100P 50V [M]
R510	ERDS2TJ182T	1.8K 1/4W [M]	R577	ERDS2TJ152T	1.5K 1/4W [M]	R912	ERDS2TJ104T	100K 1/4W [M]	C401	ECBT1H680J5	68P 50V [M]
R511	ERDS2TJ222T	2.2K 1/4W [M]	R578	ERDS2TJ152T	1.5K 1/4W [M]	R913	ERDS2TJ103T	10K 1/4W [M]	C402	ECBT1H680J5	68P 50V [M]
R512	ERDS2TJ222T	2.2K 1/4W [M]	R579	ERDS2TJ101T	100 1/4W [M]	R914	ERDS2TJ102T	1K 1/4W [M]	C403	ECEA1VKA4R7B	4.7 35V [M]
R513	ERDS2TJ331T	330 1/4W [M]	R580	ERDS2TJ101T	100 1/4W [M]	R915	ERDS2TJ122T	1.2K 1/4W [M]	C404	ECEA1VKA4R7B	4.7 35V [M]
R514	ERDS2TJ331T	330 1/4W [M]	R581	ERDS2TJ224T	220K 1/4W [M]	R916	ERDS2TJ152T	1.5K 1/4W [M]	C405	ECCR1H391J5	390P 50V [M]
R515	ERDS2TJ331T	330 1/4W [M]	R582	ERDS2TJ224T	220K 1/4W [M]	R917	ERDS2TJ103T	10K 1/4W [M]	C406	ECCR1H391J5	390P 50V [M]
R516	ERDS2TJ331T	330 1/4W [M]	R583	ERDS2TJ102T	1K 1/4W [M]	R918	ERDS2TJ102T	1K 1/4W [M]	C407	ECCR1H391J5	390P 50V [M]
R517	ERDS2TJ473T	47K 1/4W [M]	R584	ERDS2TJ102T	1K 1/4W [M]	R919	ERDS2TJ122T	1.2K 1/4W [M]	C408	ECCR1H391J5	390P 50V [M]
R518	ERDS2TJ473T	47K 1/4W [M]	R585	ERDS2TJ102T	1K 1/4W [M]	R920	ERDS2TJ152T	1.5K 1/4W [M]	C409	ECEA1HKA010B	1 50V [M]
R519	ERDS2TJ331T	330 1/4W [M]	R586	ERDS2TJ102T	1K 1/4W [M]	R921	ERDS2TJ182T	1.8K 1/4W [M]	C410	ECEA1HKA010B	1 50V [M]
R520	ERDS2TJ331T	330 1/4W [M]	R591	ERDS2TJ332T	3.3K 1/4W [M]	R922	ERDS2TJ473T	47K 1/4W [M]	C411	ECBT1H101KB5	100P 50V [M]
R521	ERDS2TJ102T	1K 1/4W [M]	R592	ERDS2TJ332T	3.3K 1/4W [M]	R923	ERDS2TJ473T	47K 1/4W [M]	C412	ECBT1H101KB5	100P 50V [M]
R522	ERDS2TJ102T	1K 1/4W [M]	R593	ERDS2TJ332T	3.3K 1/4W [M]	R924	ERDS2TJ181T	180 1/4W [M]	C413	ECBT1H221KB5	220P 50V [M]
R523	ERDS2TJ102T	1K 1/4W [M]	R594	ERDS2TJ332T	3.3K 1/4W [M]	R925	ERDS2TJ181T	180 1/4W [M]	C414	ECBT1H221KB5	220P 50V [M]

Ref No.	Part No.	Values & Remarks	Ref No.	Part No.	Values & Remarks	Ref No.	Part No.	Values & Remarks	Ref No.	Part No.	Values & Remarks
C415	ECEA1CKA100B	10 16V [M]	C517	ECBT1H102KB5	1000P 50V [M]	C575	ECBT1E103ZF5	0.01 25V [M]	C901	ECBT1H104ZF5	0.1 50V [M]
C416	ECEA1CKA100B	10 16V [M]	C518	ECBT1H102KB5	1000P 50V [M]	C577	ECBT1H102KB5	1000P 50V [M]	C902	ECEA0JKA101B	100 6.3V [M]
C417	ECBT1H102KB5	1000P 50V [M]	C521	ECBT1E103ZF5	0.01 25V [M]	C578	ECBT1H102KB5	1000P 50V [M]	C903	ECBT1E103ZF5	0.01 25V [M]
C418	ECBT1H102KB5	1000P 50V [M]	C522	ECBT1E103ZF5	0.01 25V [M]	C581	ECBT1H101KB5	100P 50V [M]	C904	ECEA0JKA101B	100 6.3V [M]
C419	ECBT1E103ZF5	0.01 25V [M]	C523	ECBT1E103ZF5	0.01 25V [M]	C582	ECBT1H101KB5	100P 50V [M]	C905	ECBT1H331KB5	330P 50V [M]
C420	ECBT1E103ZF5	0.01 25V [M]	C524	ECBT1E103ZF5	0.01 25V [M]	C583	ECBT1H101KB5	100P 50V [M]	C906	ECBT1H331KB5	330P 50V [M]
C421	ECEA1CKA100B	10 16V [M]	C525	ECBT1E103ZF5	0.01 25V [M]	C584	ECBT1H101KB5	100P 50V [M]	C907	ECBT1H331KB5	330P 50V [M]
C422	ECEA1CKA100B	10 16V [M]	C551	ECEA1VKA4R7B	4.7 35V [M]	C701	ECBT1H104ZF5	0.1 50V [M]	C908	ECBT1H331KB5	330P 50V [M]
C423	ECBT1E103ZF5	0.01 25V [M]	C552	ECEA1VKA4R7B	4.7 35V [M]	C702	ECBT1H104ZF5	0.1 50V [M]	C909	ECBT1H331KB5	330P 50V [M]
C451	ECEA1VKA4R7B	4.7 35V [M]	C553	ECEA1VKA4R7B	4.7 35V [M]	C703	ECEA1CU472E	4700 16V[M]△	C910	ECBT1H331KB5	330P 50V [M]
C452	ECBT1H221KB5	220P 50V [M]	C554	ECEA1VKA4R7B	4.7 35V [M]	C704	ECBT1E103ZF5	0.01 25V [M]	C911	ECBT1H331KB5	330P 50V [M]
C453	ECQV1H104JM3	0.1 50V [M]	C555	ECEA1VKA4R7B	4.7 35V [M]	C705	ECEA1CKA100B	10 16V [M]	C912	ECBT1H331KB5	330P 50V [M]
C454	ECQV1H104JM3	0.1 50V [M]	C556	ECEA1VKA4R7B	4.7 35V [M]	C706	ECBT1E103ZF5	0.01 25V [M]	C913	ECBT1H331KB5	330P 50V [M]
C455	ECBT1H102KB5	1000P 50V [M]	C557	ECEA1CKA100B	10 16V [M]	C707	ECEA1VU102E	1000 35V[M]△	C914	ECBT1H331KB5	330P 50V [M]
C461	ECEA1CKA100B	10 16V [M]	C558	ECEA1CKA100B	10 16V [M]	C708	ECKR1H103ZF5	0.01 50V [M]	C915	ECEA1HKA101B	1 50V [M]
C462	ECEA1CKA100B	10 16V [M]	C559	ECEA1VKA4R7B	4.7 35V [M]	C709	ECEA1CKA220B	22 16V [M]	C916	ECEA1HKA101B	1 50V [M]
C501	ECEA1VKA4R7B	4.7 35V [M]	C560	ECEA1VKA4R7B	4.7 35V [M]	C710	ECA1VM471E	470 35V [M]	C917	ECBT1E103ZF5	0.01 25V [M]
C502	ECEA1VKA4R7B	4.7 35V [M]	C561	ECCR1H331J5	330P 50V [M]	C711	ECKR1H103ZF5	0.01 50V [M]	C918	ECBT1E103ZF5	0.01 25V [M]
C503	ECEA1VKA4R7B	4.7 35V [M]	C562	ECCR1H331J5	330P 50V [M]	C712	ECEA1CKA100B	10 16V [M]	C919	ECBT1H101KB5	100P 50V [M]
C504	ECEA1VKA4R7B	4.7 35V [M]	C563	ECCR1H331J5	330P 50V [M]	C713	ECEA1CKA100B	10 16V [M]	C920	ECBT1H101KB5	100P 50V [M]
C505	ECBT1H102KB5	1000P 50V [M]	C564	ECCR1H331J5	330P 50V [M]	C714	ECA1VM101B	100 35V [M]	C921	ECEA1CKA100B	10 16V [M]
C507	ECEA1CKA100B	10 16V [M]	C565	ECEA1CKA100B	10 16V [M]	C715	ECA1JM101B	100 63V [M]	C922	ECEA1VKA220B	22 35V [M]
C508	ECEA1CKA100B	10 16V [M]	C566	ECEA1CKA100B	10 16V [M]	C716	ECKR1H103ZF5	0.01 50V [M]	C923	ECEA1VKA220B	22 35V [M]
C509	ECEA1VKA4R7B	4.7 35V [M]	C567	ECBT1H102KB5	1000P 50V [M]	C717	ECEA1VKA100B	10 35V [M]	C924	ECEA1VKA220B	22 35V [M]
C510	ECEA1VKA4R7B	4.7 35V [M]	C568	ECBT1H102KB5	1000P 50V [M]	C718	ECBT1E103ZF5	0.01 25V [M]	C925	ECEA1VKA220B	22 35V [M]
C511	ECCR1H331J5	330P 50V [M]	C569	ECBT1E103ZF5	0.01 25V [M]	C719	ECEA0JKA470B	47 6.3V [M]	C926	ECBT1E103ZF5	0.01 25V [M]
C512	ECQV1H563JM3	0.056 50V [M]	C570	ECBT1E103ZF5	0.01 25V [M]	C720	ECEA0JKA470B	47 6.3V [M]	C927	ECBT1E103ZF5	0.01 25V [M]
C513	ECCR1H331J5	330P 50V [M]	C571	ECBT1E103ZF5	0.01 25V [M]	C721	ECEA1VKA100B	10 35V [M]	C928	ECBT1H104ZF5	0.1 50V [M]
C514	ECQV1H563JM3	0.056 50V [M]	C572	ECBT1E103ZF5	0.01 25V [M]	C722	ECBT1E103ZF5	0.01 25V [M]	C931	ECBT1E103ZF5	0.01 25V [M]
C515	ECEA1CKA100B	10 16V [M]	C573	ECEA1CKA100B	10 16V [M]	C723	ECBT1H104ZF5	0.1 50V [M]			
C516	ECEA1CKA100B	10 16V [M]	C574	ECEA1CKA100B	10 16V [M]	C724	ECEA1CU221B	220 16V [M]			

■ Packaging (Refer to page 18 for the Parts List.)

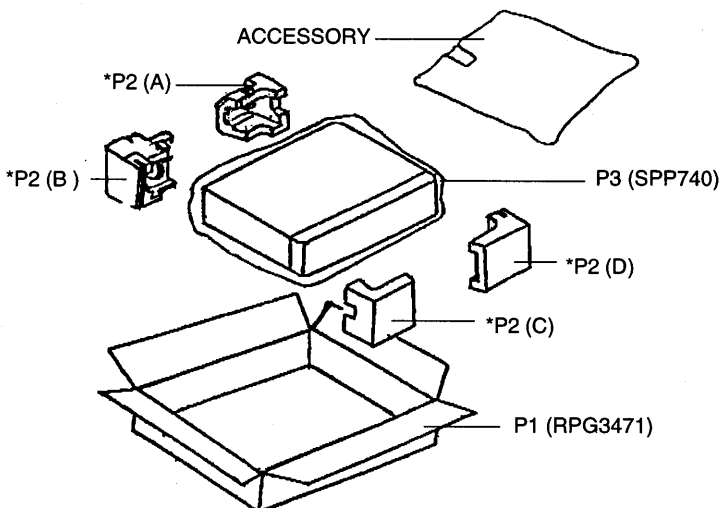

ACCESSORY

P4 (SPSD152)	: ACCESSORY BOX
A1 (EUR644378)	: REMOTE CONTROL UNIT
A2 (SJA172)	: AC CORD
A3 (RJL1P021B08)	: IP CORD
A4 (RJL2P004B08)	: STEREO CABLE
A5 (RQT3951-1Y)	: O/I BOOK
A6 (SJP2281)	: OPTICAL CABLE

